

TMS320C4x User's Guide

SPRU063C
May 1999



Printed on Recycled Paper

IMPORTANT NOTICE

Texas Instruments and its subsidiaries (TI) reserve the right to make changes to their products or to discontinue any product or service without notice, and advise customers to obtain the latest version of relevant information to verify, before placing orders, that information being relied on is current and complete. All products are sold subject to the terms and conditions of sale supplied at the time of order acknowledgement, including those pertaining to warranty, patent infringement, and limitation of liability.

TI warrants performance of its semiconductor products to the specifications applicable at the time of sale in accordance with TI's standard warranty. Testing and other quality control techniques are utilized to the extent TI deems necessary to support this warranty. Specific testing of all parameters of each device is not necessarily performed, except those mandated by government requirements.

CERTAIN APPLICATIONS USING SEMICONDUCTOR PRODUCTS MAY INVOLVE POTENTIAL RISKS OF DEATH, PERSONAL INJURY, OR SEVERE PROPERTY OR ENVIRONMENTAL DAMAGE ("CRITICAL APPLICATIONS"). TI SEMICONDUCTOR PRODUCTS ARE NOT DESIGNED, AUTHORIZED, OR WARRANTED TO BE SUITABLE FOR USE IN LIFE-SUPPORT DEVICES OR SYSTEMS OR OTHER CRITICAL APPLICATIONS. INCLUSION OF TI PRODUCTS IN SUCH APPLICATIONS IS UNDERSTOOD TO BE FULLY AT THE CUSTOMER'S RISK.

In order to minimize risks associated with the customer's applications, adequate design and operating safeguards must be provided by the customer to minimize inherent or procedural hazards.

TI assumes no liability for applications assistance or customer product design. TI does not warrant or represent that any license, either express or implied, is granted under any patent right, copyright, mask work right, or other intellectual property right of TI covering or relating to any combination, machine, or process in which such semiconductor products or services might be or are used. TI's publication of information regarding any third party's products or services does not constitute TI's approval, warranty or endorsement thereof.

Read This First

About This Manual

This user's guide serves as a reference book for the TMS320C40 and TMS320C44 digital signal processors. Throughout the book, all references to the TMS320C4x apply to both devices, except when otherwise noted.

How to Use This Manual

The following table summarizes the information contained in this user's guide:

If you are looking for information about:	Turn to these chapters:
Addressing modes	Chapter 6, <i>Addressing Modes</i>
ARAUs	Chapter 2, <i>Architectural Overview</i>
Bootloader	Chapter 10, <i>The Bootloader</i>
Bus Structure	Chapter 2, <i>Architectural Overview</i> Chapter 9, <i>External Bus Operation</i>
Cache	Chapter 4, <i>Memory and the Instruction Cache</i>
Communication Ports	Chapter 12, <i>Communication Ports</i>
CPU Architecture	Chapter 2, <i>Architectural Overview</i> Chapter 3, <i>CPU Registers</i>
DMA	Chapter 11, <i>The DMA Coprocessor</i>
Data Formats	Chapter 5, <i>Data Formats and Floating-Point Operation</i>
Delayed Branches	Chapter 7, <i>Program Flow Control</i>
Instruction set	Chapter 14, <i>Assembly Language Instructions</i>

If you are looking for information about:	Turn to these chapters:
Interrupts	Chapter 7, <i>Program Flow Control</i>
Memory	Chapter 2, <i>Architectural Overview</i> Chapter 4, <i>Memory and the Instruction Cache</i>
Peripherals	Chapter 12, <i>Communication Ports</i> Chapter 11, <i>The DMA Coprocessor</i> Chapter 13, <i>Timers</i>
Overview of the 'C4x	Chapter 1, <i>Introduction</i>
Program control	Chapter 7, <i>Program Flow Control</i>
Pipeline	Chapter 8, <i>Pipeline Operation</i>
Registers	Chapter 3, <i>CPU Registers</i> Chapter 12, <i>Communication Ports</i> Chapter 11, <i>The DMA Coprocessor</i> Chapter 13, <i>Timers</i>
Repeat Mode	Chapter 7, <i>Program Flow Control</i>
Reset	Chapter 7, <i>Program Flow Control</i>
Timers	Chapter 13, <i>Timers</i>
Traps	Chapter 7, <i>Program Flow Control</i>

Style and Symbol Conventions

This document uses the following conventions:

- Program listings, program examples, file names, and symbol names are shown in a special font. Examples use a bold version of the special font for emphasis. Here is a sample program listing segment:

```

*
LOOP1  RPTB   MAX
        CMPF  *AR0,R0      ;Compare number to the maximum
MAX    LDFLT  *AR0,R0      ;If greater, this is a new max
        B     NEXT
LOOP2  RPTB   MIN
        CMPF  *AR0++(1),R0 ;Compare number to the minimum
MIN    LDFLT  *-AR0(1),R0  ;If smaller, this is new minimum
NEXT   .
        .
    
```

- In syntax descriptions, the instruction is in **bold face** and the parameters are in *italic face*. Portions of a syntax that are in **bold face** should be entered as shown; portions of a syntax that are in *italic face* describe the *type* of information that should be entered. Here is an example of an instruction:

CMPF3 *src2,src1*

Notice that although the instruction mnemonic (CMPF3 in this example) is in capital letters, the 'C4x assembler **is not case sensitive** — it can assemble mnemonics entered in either upper or lower case.

CMPF3 is the instruction mnemonic. This instruction has two parameters, indicated by *src2* and *src1*.

- Square brackets ([and]) identify an optional parameter. If you use an optional parameter, you must specify the information within the brackets; however, you don't enter the brackets themselves. Here's an example of an instruction that has an optional parameter:

[*label*] **LDP** *src* [,*DP*]

The **LDP** instruction is shown with two parameters; one is optional. The first parameter, *src*, is required. The second parameter, *DP*, and the label, are optional. As this syntax shows, if you use the optional second parameter, you must precede it with a comma.

- Throughout this book MSB indicates the most significant bit and LSB indicates the least significant bit. MS indicates the most significant byte and LS indicates the least significant byte.

Information About Cautions and Warnings

This book may contain cautions and warnings.

This is an example of a caution statement.

A caution statement describes a situation that could potentially damage your software or equipment.

This is an example of a warning statement.

A warning statement describes a situation that could potentially cause harm to you.

The information in a caution or a warning is provided for your protection. Please read each caution and warning carefully.

Related Documentation From Texas Instruments

The following books describe the TMS320 floating-point devices and related support tools. To obtain a copy of any of these TI documents, call the Texas Instruments Literature Response Center at (800) 477–8924. When ordering, please identify the book by its title and literature number.

TMS320C4x General-Purpose Applications User's Guide (literature number SPRU159) describes software and hardware applications for the 'C4x processor. Also includes development support information, parts lists, and XDS510 emulator design considerations.

TMS320C4x Parallel Processing Development System Technical Reference (literature number SPRU075) describes the TMS320C4x parallel processing system, a system with four C4xs with shared and distributed memory.

Parallel Processing with the TMS320C4x (literature number SPRA031) describes parallel processing and how the 'C4x can be used in parallel processing. Also provides sample parallel processing applications.

TMS320 Floating-Point DSP Assembly Language Tools User's Guide (literature number SPRU035) describes the assembly language tools (assembler, linker, and other tools used to develop assembly language code), assembler directives, macros, common object file format, and symbolic debugging directives for the 'C3x and 'C4x generations of devices.

TMS320 Floating-Point DSP Optimizing C Compiler User's Guide (literature number SPRU034) describes the TMS320 floating-point C compiler. This C compiler accepts ANSI standard C source code and produces TMS320 assembly language source code for the 'C3x and 'C4x generations of devices.

TMS320C4x C Source Debugger User's Guide (literature number SPRU054) tells you how to invoke the 'C4x emulator and simulator versions of the C source debugger interface. This book discusses various aspects of the debugger interface, including window management, command entry, code execution, data management, and breakpoints. It also includes a tutorial that introduces basic debugger functionality.

TMS320C4x Technical Brief (literature number SPRU076) gives a condensed overview of the 'C4x DSP and its development tools. It also lists TMS320C4x third parties.

TMS320 Family Development Support Reference Guide (literature number SPRU011) describes the '320 family of digital signal processors and the various products that support it. This includes code-generation tools (compilers, assemblers, linkers, etc.) and system integration and debug tools (simulators, emulators, evaluation modules, etc.). This book also lists related documentation, outlines seminars and the university program, and gives factory repair and exchange information.

TMS320 Third-Party Support Reference Guide (literature number SPRU052) alphabetically lists over 100 third parties that supply various products that serve the family of '320 digital signal processors—software and hardware development tools, speech recognition, image processing, noise cancellation, modems, etc.

TMS320 DSP Designer's Notebook: Volume 1 (SPRT125). Presents solutions to common design problems using 'C2x, 'C3x, 'C4x, 'C5x, and other TI DSPs.

Related Articles and Books

A wide variety of related documentation is available on digital signal processing. These references fall into one of the following application categories:

- General-Purpose DSP
- Graphics/Imagery
- Speech/Voice
- Control
- Multimedia
- Military
- Telecommunications
- Automotive
- Consumer
- Medical
- Development Support

In the following list, references appear in alphabetical order according to author. The documents contain beneficial information regarding designs, operations, and applications for signal-processing systems; all of the documents provide additional references. Texas Instruments strongly suggests that you refer to these publications.

General-Purpose DSP:

- 1) Antoniou, A., *Digital Filters: Analysis and Design*, New York, NY: McGraw-Hill Company, Inc., 1979.

- 2) Brigham, E.O., *The Fast Fourier Transform*, Englewood Cliffs, NJ: Prentice-Hall, Inc., 1974.
- 3) Burrus, C.S., and T.W. Parks, *DFT/FFT and Convolution Algorithms*, New York, NY: John Wiley and Sons, Inc., 1984.
- 4) Chassaing, R., Horning, D.W., "Digital Signal Processing with Fixed and Floating-Point Processors." *CoED, USA*, Volume 1, Number 1, pages 1–4, March 1991.
- 5) Defatta, David J., Joseph G. Lucas, and William S. Hodgkiss, *Digital Signal Processing: A System Design Approach*, New York: John Wiley, 1988.
- 6) Erskine, C., and S. Magar, "Architecture and Applications of a Second-Generation Digital Signal Processor." *Proceedings of IEEE International Conference on Acoustics, Speech, and Signal Processing*, USA, 1985.
- 7) Essig, D., C. Erskine, E. Caudel, and S. Magar, "A Second-Generation Digital Signal Processor." *IEEE Journal of Solid-State Circuits*, USA, Volume SC–21, Number 1, pages 86–91, February 1986.
- 8) Frantz, G., K. Lin, J. Reimer, and J. Bradley, "The Texas Instruments TMS320C25 Digital Signal Microcomputer." *IEEE Microelectronics*, USA, Volume 6, Number 6, pages 10–28, December 1986.
- 9) Gass, W., R. Tarrant, T. Richard, B. Pawate, M. Gammel, P. Rajasekaran, R. Wiggins, and C. Covington, "Multiple Digital Signal Processor Environment for Intelligent Signal Processing." *Proceedings of the IEEE, USA*, Volume 75, Number 9, pages 1246–1259, September 1987.
- 10) Gold, Bernard, and C.M. Rader, *Digital Processing of Signals*, New York, NY: McGraw-Hill Company, Inc., 1969.
- 11) Hamming, R.W., *Digital Filters*, Englewood Cliffs, NJ: Prentice-Hall, Inc., 1977.
- 12) IEEE ASSP DSP Committee (Editor), *Programs for Digital Signal Processing*, New York, NY: IEEE Press, 1979.
- 13) Jackson, Leland B., *Digital Filters and Signal Processing*, Hingham, MA: Kluwer Academic Publishers, 1986.
- 14) Jones, D.L., and T.W. Parks, *A Digital Signal Processing Laboratory Using the TMS32010*, Englewood Cliffs, NJ: Prentice-Hall, Inc., 1987.
- 15) Lim, Jae, and Alan V. Oppenheim, *Advanced Topics in Signal Processing*, Englewood Cliffs, NJ: Prentice-Hall, Inc., 1988.

- 16) Lin, K., G. Frantz, and R. Simar, Jr., "The TMS320 Family of Digital Signal Processors." *Proceedings of the IEEE*, USA, Volume 75, Number 9, pages 1143–1159, September 1987.
- 17) Lovrich, A., Reimer, J., "An Advanced Audio Signal Processor." *Digest of Technical Papers for 1991 International Conference on Consumer Electronics*, June 1991.
- 18) Magar, S., D. Essig, E. Caudel, S. Marshall and R. Peters, "An NMOS Digital Signal Processor with Multiprocessing Capability." *Digest of IEEE International Solid-State Circuits Conference*, USA, February 1985.
- 19) Morris, Robert L., *Digital Signal Processing Software*, Ottawa, Canada: Carleton University, 1983.
- 20) Oppenheim, Alan V. (Editor), *Applications of Digital Signal Processing*, Englewood Cliffs, NJ: Prentice-Hall, Inc., 1978.
- 21) Oppenheim, Alan V., and R.W. Schaffer, *Digital Signal Processing*, Englewood Cliffs, NJ: Prentice-Hall, Inc., 1975 and 1988.
- 22) Oppenheim, A.V., A.N. Willsky, and I.T. Young, *Signals and Systems*, Englewood Cliffs, NJ: Prentice-Hall, Inc., 1983.
- 23) Papamichalis, P.E., and C.S. Burrus, "Conversion of Digit-Reversed to Bit-Reversed Order in FFT Algorithms." *Proceedings of ICASSP 89*, USA, pages 984–987, May 1989.
- 24) Papamichalis, P., and R. Simar, Jr., "The TMS320C30 Floating-Point Digital Signal Processor." *IEEE Micro Magazine*, USA, pages 13–29, December 1988.
- 25) Parks, T.W., and C.S. Burrus, *Digital Filter Design*, New York, NY: John Wiley and Sons, Inc., 1987.
- 26) Peterson, C., Zervakis, M., Shehadeh, N., "Adaptive Filter Design and Implementation Using the TMS320C25 Microprocessor." *Computers in Education Journal*, USA, Volume 3, Number 3, pages 12–16, July–September 1993.
- 27) Prado, J., and R. Alcantara, "A Fast Square-Rooting Algorithm Using a Digital Signal Processor." *Proceedings of IEEE*, USA, Volume 75, Number 2, pages 262–264, February 1987.
- 28) Rabiner, L.R. and B. Gold, *Theory and Applications of Digital Signal Processing*, Englewood Cliffs, NJ: Prentice-Hall, Inc., 1975.
- 29) Simar, Jr., R., and A. Davis, "The Application of High-Level Languages to Single-Chip Digital Signal Processors." *Proceedings of ICASSP 88*, USA, Volume D, page 1678, April 1988.

- 30) Simar, Jr., R., T. Leigh, P. Koeppen, J. Leach, J. Potts, and D. Blalock, "A 40 MFLOPS Digital Signal Processor: the First Supercomputer on a Chip." *Proceedings of ICASSP 87, USA*, Catalog Number 87CH2396-0, Volume 1, pages 535-538, April 1987.
- 31) Simar, Jr., R., and J. Reimer, "The TMS320C25: a 100 ns CMOS VLSI Digital Signal Processor." *1986 Workshop on Applications of Signal Processing to Audio and Acoustics*, September 1986.
- 32) Texas Instruments, *Digital Signal Processing Applications with the TMS320 Family*, 1986; Englewood Cliffs, NJ: Prentice-Hall, Inc., 1987.
- 33) Treichler, J.R., C.R. Johnson, Jr., and M.G. Larimore, *A Practical Guide to Adaptive Filter Design*, New York, NY: John Wiley and Sons, Inc., 1987.

Graphics/Imagery:

- 1) Andrews, H.C., and B.R. Hunt, *Digital Image Restoration*, Englewood Cliffs, NJ: Prentice-Hall, Inc., 1977.
- 2) Gonzales, Rafael C., and Paul Wintz, *Digital Image Processing*, Reading, MA: Addison-Wesley Publishing Company, Inc., 1977.
- 3) Papamichalis, P.E., "FFT Implementation on the TMS320C30." *Proceedings of ICASSP 88, USA*, Volume D, page 1399, April 1988.
- 4) Pratt, William K., *Digital Image Processing*, New York, NY: John Wiley and Sons, 1978.
- 5) Reimer, J., and A. Lovrich, "Graphics with the TMS32020." *WESCON/85 Conference Record*, USA, 1985.

Speech/Voice:

- 1) DellaMorte, J., and P. Papamichalis, "Full-Duplex Real-Time Implementation of the FED-STD-1015 LPC-10e Standard V.52 on the TMS320C25." *Proceedings of SPEECH TECH 89*, pages 218-221, May 1989.
- 2) Frantz, G.A., and K.S. Lin, "A Low-Cost Speech System Using the TMS320C17." *Proceedings of SPEECH TECH '87*, pages 25-29, April 1987.
- 3) Gray, A.H., and J.D. Markel, *Linear Prediction of Speech*, New York, NY: Springer-Verlag, 1976.
- 4) Jayant, N.S., and Peter Noll, *Digital Coding of Waveforms*, Englewood Cliffs, NJ: Prentice-Hall, Inc., 1984.
- 5) Papamichalis, Panos, *Practical Approaches to Speech Coding*, Englewood Cliffs, NJ: Prentice-Hall, Inc., 1987.
- 6) Papamichalis, P., and D. Lively, "Implementation of the DOD Standard LPC-10/52E on the TMS320C25." *Proceedings of SPEECH TECH '87*, pages 201-204, April 1987.

- 7) Pawate, B.I., and G.R. Doddington, "Implementation of a Hidden Markov Model-Based Layered Grammar Recognizer." *Proceedings of ICASSP 89*, USA, pages 801–804, May 1989.
- 8) Rabiner, L.R., and R.W. Schafer, *Digital Processing of Speech Signals*, Englewood Cliffs, NJ: Prentice-Hall, Inc., 1978.
- 9) Reimer, J.B. and K.S. Lin, "TMS320 Digital Signal Processors in Speech Applications." *Proceedings of SPEECH TECH '88*, April 1988.
- 10) Reimer, J.B., M.L. McMahan, and W.W. Anderson, "Speech Recognition for a Low-Cost System Using a DSP." *Digest of Technical Papers for 1987 International Conference on Consumer Electronics*, June 1987.

Control:

- 1) Ahmed, I., "16-Bit DSP Microcontroller Fits Motion Control System Application." *PCIM*, October 1988.
- 2) Ahmed, I., "Implementation of Self Tuning Regulators with TMS320 Family of Digital Signal Processors." *MOTORCON '88*, pages 248–262, September 1988.
- 3) Ahmed, I., and S. Lindquist, "Digital Signal Processors: Simplifying High-Performance Control." *Machine Design*, September 1987.
- 4) Ahmed, I., and S. Meshkat, "Using DSPs in Control." *Control Engineering*, February 1988.
- 5) Allen, C. and P. Pillay, "TMS320 Design for Vector and Current Control of AC Motor Drives." *Electronics Letters*, UK, Volume 28, Number 23, pages 2188–2190, November 1992.
- 6) Bose, B.K., and P.M. Szczesny, "A Microcomputer-Based Control and Simulation of an Advanced IPM Synchronous Machine Drive System for Electric Vehicle Propulsion." *Proceedings of IECON '87*, Volume 1, pages 454–463, November 1987.
- 7) Hanselman, H., "LQG-Control of a Highly Resonant Disc Drive Head Positioning Actuator." *IEEE Transactions on Industrial Electronics*, USA, Volume 35, Number 1, pages 100–104, February 1988.
- 8) Jacquot, R., *Modern Digital Control Systems*, New York, NY: Marcel Dekker, Inc., 1981.
- 9) Katz, P., *Digital Control Using Microprocessors*, Englewood Cliffs, NJ: Prentice-Hall, Inc., 1981.
- 10) Kuo, B.C., *Digital Control Systems*, New York, NY: Holt, Reinholt, and Winston, Inc., 1980.

- 11) Lovrich, A., G. Troullinos, and R. Chirayil, "An All-Digital Automatic Gain Control." *Proceedings of ICASSP 88, USA*, Volume D, page 1734, April 1988.
- 12) Matsui, N. and M. Shigyo, "Brushless DC Motor Control Without Position and Speed Sensors." *IEEE Transactions on Industry Applications, USA*, Volume 28, Number 1, Part 1, pages 120–127, January–February 1992.
- 13) Meshkat, S., and I. Ahmed, "Using DSPs in AC Induction Motor Drives." *Control Engineering*, February 1988.
- 14) Panahi, I. and R. Restle, "DSPs Redefine Motion Control." *Motion Control Magazine*, December 1993.
- 15) Phillips, C., and H. Nagle, *Digital Control System Analysis and Design*, Englewood Cliffs, NJ: Prentice-Hall, Inc., 1984.

Multimedia:

- 1) Reimer, J., "DSP-Based Multimedia Solutions Lead Way Enhancing Audio Compression Performance." *Dr. Dobbs Journal*, December 1993.
- 2) Reimer, J., G. Benbassat, and W. Bonneau Jr., "Application Processors: Making PC Multimedia Happen." *Silicon Valley PC Design Conference*, July 1991.

Military:

- 1) Papamichalis, P., and J. Reimer, "Implementation of the Data Encryption Standard Using the TMS32010." *Digital Signal Processing Applications*, 1986.

Telecommunications:

- 1) Ahmed, I., and A. Lovrich, "Adaptive Line Enhancer Using the TMS320C25." *Conference Records of Northcon/86, USA*, 14/3/1–10, September/October 1986.
- 2) Casale, S., R. Russo, and G. Bellina, "Optimal Architectural Solution Using DSP Processors for the Implementation of an ADPCM Transcoder." *Proceedings of GLOBECOM '89*, pages 1267–1273, November 1989.
- 3) Cole, C., A. Haoui, and P. Winship, "A High-Performance Digital Voice Echo Canceller on a SINGLE TMS32020." *Proceedings of ICASSP 86, USA*, Catalog Number 86CH2243–4, Volume 1, pages 429–432, April 1986.
- 4) Cole, C., A. Haoui, and P. Winship, "A High-Performance Digital Voice Echo Canceller on a Single TMS32020." *Proceedings of IEEE*

- International Conference on Acoustics, Speech and Signal Processing, USA, 1986.*
- 5) Lovrich, A., and J. Reimer, "A Multi-Rate Transcoder." *Transactions on Consumer Electronics, USA, November 1989.*
 - 6) Lovrich, A. and J. Reimer, "A Multi-Rate Transcoder." *Digest of Technical Papers for 1989 International Conference on Consumer Electronics, June 7–9, 1989.*
 - 7) Lu, H., D. Hedberg, and B. Fraenkel, "Implementation of High-Speed Voiceband Data Modems Using the TMS320C25." *Proceedings of ICASSP 87, USA, Catalog Number 87CH2396–0, Volume 4, pages 1915–1918, April 1987.*
 - 8) Mock, P., "Add DTMF Generation and Decoding to DSP– μ P Designs." *Electronic Design, USA, Volume 30, Number 6, pages 205–213, March 1985.*
 - 9) Reimer, J., M. McMahan, and M. Arjmand, "ADPCM on a TMS320 DSP Chip." *Proceedings of SPEECH TECH 85, pages 246–249, April 1985.*
 - 10) Troullinos, G., and J. Bradley, "Split-Band Modem Implementation Using the TMS32010 Digital Signal Processor." *Conference Records of Electro/86 and Mini/Micro Northeast, USA, 14/1/1–21, May 1986.*

Automotive:

- 1) Lin, K., "Trends of Digital Signal Processing in Automotive." *International Congress on Transportation Electronic (CONVERGENCE '88), October 1988.*

Consumer:

- 1) Frantz, G.A., J.B. Reimer, and R.A. Wotiz, "Julie, The Application of DSP to a Product." *Speech Tech Magazine, USA, September 1988.*
- 2) Reimer, J.B., and G.A. Frantz, "Customization of a DSP Integrated Circuit for a Customer Product." *Transactions on Consumer Electronics, USA, August 1988.*
- 3) Reimer, J.B., P.E. Nixon, E.B. Boles, and G.A. Frantz, "Audio Customization of a DSP IC." *Digest of Technical Papers for 1988 International Conference on Consumer Electronics, June 8–10 1988.*

Medical:

- 1) Knapp and Townshend, "A Real-Time Digital Signal Processing System for an Auditory Prosthesis." *Proceedings of ICASSP 88, USA, Volume A, page 2493, April 1988.*

- 2) Morris, L.R., and P.B. Barszczewski, "Design and Evolution of a Pocket-Sized DSP Speech Processing System for a Cochlear Implant and Other Hearing Prosthesis Applications." *Proceedings of ICASSP 88*, USA, Volume A, page 2516, April 1988.

Development Support:

- 1) Mersereau, R., R. Schafer, T. Barnwell, and D. Smith, "A Digital Filter Design Package for PCs and TMS320." *MIDCON/84 Electronic Show and Convention*, USA, 1984.
- 2) Simar, Jr., R., and A. Davis, "The Application of High-Level Languages to Single-Chip Digital Signal Processors." *Proceedings of ICASSP 88*, USA, Volume 3, pages 1678–1681, April 1988.

If You Need Assistance. . .

If you want to. . .	Do this. . .
Request more information about Texas Instruments Digital Signal Processing (DSP) products	Write to: Texas Instruments Incorporated Market Communications Manager MS 736 P.O. Box 1443 Houston, Texas 77251-1443
Order Texas Instruments documentation	Call the TI Literature Response Center: (800) 477-8924
Ask questions about product operation or report suspected problems	Contact the DSP hotline: Phone: (713) 274-2320 FAX: (713) 274-2324 Electronic Mail: 4389750@mcimail.com .
Obtain the source code in this user's guide.	Call the TI BBS: (713) 274-2323 Ftp from: ftp.ti.com log in as user ftp cd to /mirrors/tms320bbs
Visit TI online, including TI&ME™, your own customized web page.	Point your browser at: http://www.ti.com
Report mistakes or make comments about this or any other TI documentation.	Send electronic mail to: comments@books.sc.ti.com Send printed comments to: Texas Instruments Incorporated Technical Publications Mgr., MS 702 P.O. Box 1443 Houston, Texas 77251-1443

Trademarks

MS is a registered trademark of Microsoft Corp.

MS-Windows is a registered trademark of Microsoft Corp.

MS-DOS is a registered trademark of Microsoft Corp.

OS/2 is a trademark of International Business Machines Corp.

Sun and SPARC are trademarks of Sun Microsystems, Inc.

VAX and VMS are trademarks of Digital Equipment Corp.

Contents

1	Introduction	1-1
	<i>Introduces the TMS320 family and the TMS320C4x</i>	
1.1	TMS320C4x Devices	1-2
1.1.1	The TMS320C40	1-2
1.1.2	The TMS320C44	1-2
1.2	Key Features of the TMS320C4x	1-3
1.3	TMS320C40 and TMS320C44 Device Comparison	1-4
2	Architectural Overview	2-1
	<i>Briefly describes the architecture of the CPU, buses, interrupts, and peripherals of the 'C4x</i>	
2.1	Central Processing Unit (CPU)	2-4
2.1.1	Floating-Point/Integer Multiplier	2-4
2.1.2	Arithmetic Logic Unit (ALU) and Internal Buses	2-4
2.1.3	Auxiliary Register Arithmetic Units (ARAUs)	2-6
2.1.4	CPU Primary Register File	2-6
2.1.5	CPU Expansion Register File	2-10
2.2	Memory Organization	2-11
2.2.1	RAM, ROM, and Cache	2-11
2.2.2	Memory Maps	2-13
2.2.3	Memory Aliasing ('C44 only)	2-17
2.2.4	Memory Addressing Modes	2-18
2.3	Internal Bus Operation	2-19
2.4	External Bus Operation	2-20
2.5	Interrupts	2-21
2.6	Peripherals	2-22
2.6.1	Communication Ports	2-23
2.6.2	Direct Memory Access (DMA) Coprocessor	2-23
2.6.3	Timers	2-24

3	CPU Registers	3-1
	<i>Lists and describes the contents of the CPU primary register file and the CPU expansion register file</i>	
3.1	CPU Primary Register File	3-2
3.1.1	Extended-Precision Registers (R0–R11)	3-3
3.1.2	Auxiliary Registers (AR0–AR7)	3-4
3.1.3	Data-Page Pointer (DP)	3-4
3.1.4	Index Registers (IR0, IR1)	3-4
3.1.5	Block-Size Register (BK)	3-5
3.1.6	System Stack Pointer (SP)	3-5
3.1.7	Status Register (ST)	3-5
3.1.8	DMA Coprocessor Interrupt Enable Register (DIE)	3-8
3.1.9	CPU Internal Interrupt Enable Register (IIE)	3-11
3.1.10	IIOF Flag Register (IIF)	3-13
3.1.11	Block-Repeat (RS, RE) and Repeat-Count (RC) Registers	3-16
3.1.12	Program Counter (PC)	3-16
3.1.13	Reserved Bits and Compatibility	3-16
3.2	CPU Expansion Register File	3-17
4	Memory and the Instruction Cache	4-1
	<i>Describes the structure of the memory map and the architecture of the instruction cache</i>	
4.1	Memory Map	4-2
4.2	Peripheral Bus Memory Map	4-5
4.2.1	Local and Global Memory Interface Control Registers	4-6
4.2.2	Analysis Module Registers	4-6
4.2.3	Timer Registers	4-7
4.2.4	Communication Port Memory Map	4-8
4.2.5	DMA Coprocessor Registers	4-9
4.3	Instruction Cache	4-10
4.3.1	Instruction Cache Architecture	4-10
4.3.2	Cache Control Bits	4-12
4.3.3	Using the Cache	4-13
4.3.4	The LRU Cache Algorithm	4-14
5	Data Formats and Floating-Point Operation	5-1
	<i>Describes integer and floating-point data formats and discusses how some mathematical operations are performed on floating-point numbers</i>	
5.1	Signed-Integer Formats	5-2
5.1.1	Short Integer Format	5-2
5.1.2	Single-Precision Integer Format	5-2
5.2	Unsigned-Integer Formats	5-3
5.2.1	Short Unsigned-Integer Format	5-3
5.2.2	Single-Precision Unsigned-Integer Format	5-3

5.3	Floating-Point Formats	5-4
5.3.1	Short Floating-Point Format	5-5
5.3.2	Single-Precision Floating-Point Format	5-6
5.3.3	Extended-Precision Floating-Point Format	5-7
5.3.4	Determining the Decimal Equivalent of a Floating-Point Number	5-8
5.3.5	Conversion Between Floating-Point Formats	5-11
5.4	Floating-Point Conversion (IEEE Std. 754)	5-13
5.4.1	Converting IEEE Format to Twos-Complement 'C4x Floating-Point Format	5-14
5.4.2	Converting Twos-Complement 'C4x Floating-Point Format to IEEE Format	5-17
5.5	Floating-Point Multiplication	5-19
5.6	Floating-Point Addition and Subtraction	5-23
5.7	Normalization (NORM Instruction)	5-27
5.8	Rounding (RND Instruction)	5-29
5.9	Floating-Point-to-Integer Conversion (FIX Instruction)	5-31
5.10	Integer-to-Floating-Point Conversion (FLOAT Instruction)	5-33
5.11	Reciprocal (RCPF Instruction)	5-34
5.11.1	Reciprocal Algorithm	5-35
5.12	Reciprocal Square Root (RSQRF Instruction)	5-36
	Newton-Raphson Algorithm	5-37
6	Addressing Modes	6-1
	<i>Describes addressing modes, using address registers, and stack managements in the 'C4x</i>	
6.1	Addressing Types	6-2
6.2	Register Addressing	6-3
6.3	Direct Addressing	6-5
6.4	Indirect Addressing	6-6
6.5	Immediate Addressing	6-18
6.6	PC-Relative Addressing	6-19
6.7	Encoding of Addressing Modes	6-21
6.7.1	General Addressing Modes	6-21
6.7.2	Three-Operand Addressing Modes	6-22
6.7.3	Parallel Addressing Modes	6-24
6.7.4	Conditional-Branch Addressing Modes	6-25
6.8	Circular Addressing	6-27
6.9	Bit-Reversed Addressing	6-32
7	Program Flow Control	7-1
	<i>Describes software and hardware features that control how a program flows</i>	
7.1	Repeat Mode	7-2
7.1.1	Control Bits	7-3
7.1.2	Repeat-Mode Operation	7-3
7.1.3	RPTB and RPTBD Instructions	7-4
7.1.4	RPTS Instruction	7-5
7.1.5	Repeat Mode Restriction Rules	7-6
7.1.6	RC Register Value After Repeat Mode Completes	7-7
7.1.7	Nesting Block Repeats	7-8

7.2	Delayed Branches	7-9
7.2.1	Delayed Branches Without Annulling	7-10
7.2.2	Delayed Branches With Annulling	7-11
7.3	Calls, Traps, Branches, Jumps, and Returns	7-12
7.4	Interrupts	7-15
7.4.1	Interrupt Vector Table and Prioritization	7-15
7.4.2	CPU Interrupt Control Bits	7-17
7.4.3	Interrupt Processing	7-18
7.4.4	CPU Interrupt Latency	7-20
7.4.5	External Interrupts	7-21
7.5	Traps	7-24
7.5.1	Initialization of Traps and Interrupts	7-24
7.5.2	Operation of Traps	7-24
7.5.3	Overlapping the Trap and Interrupt Vector Tables	7-25
7.6	DMA Interrupts	7-26
7.6.1	DMA Interrupt Control Bits	7-26
7.6.2	DMA Interrupt Processing	7-27
7.6.3	CPU/DMA Interrupt Interaction	7-28
7.7	Reset	7-29
7.7.1	Reset's Effects on Pin States	7-29
7.7.2	Reset Vector Location	7-35
7.7.3	Additional Reset Operations	7-35
8	Pipeline Operation	8-1
	<i>Describes and explains the operation of the four pipeline stages in the 'C4x CPU</i>	
8.1	Pipeline Structure	8-2
8.2	Pipeline Conflicts	8-4
8.2.1	Branch Conflicts	8-4
8.2.2	Register Conflicts	8-8
8.2.3	Memory Conflicts	8-10
8.3	Memory Accesses for Maximum Performance	8-17
8.4	Clocking of Memory Accesses	8-19
8.4.1	Program Fetches	8-19
8.4.2	Data Loads and Stores	8-20
9	External Bus Operation	9-1
	<i>Describes the features and functions of the two 'C4x external buses</i>	
9.1	Overview	9-2
9.2	Memory Interface Signals	9-3
9.3	Memory-Interface Control Registers	9-6
9.3.1	Mapping Addresses to Strobes	9-12
9.3.2	Page Size Operation	9-13
9.4	Programmable Wait States	9-14
9.5	Memory Interface Timing	9-16

9.6	Using Enable Signals to Control Signal Groups	9-38
9.7	Interlocked Operations	9-39
9.7.1	LDFI and LDII	9-40
9.7.2	STFI and STII	9-40
9.7.3	SIGI	9-41
9.7.4	Interlocked Examples	9-41
9.7.5	Bus-Lock Pins and Bus Timing	9-44
9.8	IACK Timing	9-49
10	The Bootloader	10-1
	<i>Describes 'C4x bootloader operation and also lists the bootloader code</i>	
10.1	Bootloader Description	10-2
10.2	Mode Selection	10-3
10.3	Bootloading Sequence	10-5
10.4	Bootloading from External Memory (Examples)	10-10
10.5	Bootloading from a Communication Port (Examples)	10-16
10.6	Modifying the $\overline{\text{I/O}}\text{Fx}$ Pins After Bootloading	10-19
10.7	The Bootloader Program	10-20
11	The DMA Coprocessor	11-1
	<i>Describes and discusses operation of the 'C4x DMA coprocessor</i>	
11.1	Introduction	11-2
11.2	DMA Functional Description	11-3
11.2.1	DMA Basic Operation	11-5
11.3	DMA Registers	11-7
11.3.1	Control Register	11-7
11.3.2	Address and Index Registers	11-15
11.3.3	Transfer Counter and Auxiliary Transfer Counter Registers	11-16
11.3.4	Link Pointer and Auxiliary Link-Pointer Registers	11-17
11.4	DMA Unified Mode	11-19
11.5	DMA Split Mode	11-20
11.6	DMA Internal Priority Schemes	11-22
11.6.1	Fixed Priority Scheme	11-22
11.6.2	Rotating Priority Scheme	11-22
11.6.3	Split Mode and DMA Channel Arbitration	11-24
11.7	CPU and DMA Coprocessor Arbitration	11-27
11.8	Data Transfer Modes	11-28
11.8.1	Running in TRANSFER MODE = 002	11-28
11.8.2	Running in TRANSFER MODE = 012	11-29
11.8.3	Running in TRANSFER MODE = 102 (Autoinitialization 1)	11-29
11.8.4	Running in TRANSFER MODE = 112 (Autoinitialization 2)	11-31

11.9	Autoinitialization	11-34
11.9.1	Unified Mode	11-35
11.9.2	Split Mode	11-35
11.9.3	Incrementing the Link Pointer	11-36
11.9.4	Synchronization	11-37
11.9.5	Effect on DMA Control Register Bits	11-38
11.9.6	Consecutive Autoinitializations	11-40
11.10	DMA and Interrupts	11-42
11.10.1	Interrupts and Synchronization of DMA Channels	11-43
11.10.2	Synchronization Mode Bits	11-46
11.11	DMA Memory Transfer Timing	11-51
11.11.1	Single DMA Memory Transfer Timing	11-51
11.11.2	DMA Transfer Rate in Synchronization Mode	11-55
12	Communication Ports	12-1
	<i>Describes and provides tips for using the communication ports</i>	
12.1	Features	12-2
12.2	Operational Overview	12-3
12.2.1	Token Transfer Operation	12-5
12.2.2	Data Transfer Operation	12-6
12.3	Memory Map and Registers	12-7
12.3.1	Communication-Port Control Register (CPCR)	12-8
12.3.2	Input-Port Register	12-9
12.3.3	Output-Port Register	12-9
12.3.4	Communication-Port Software Reset Register	12-10
12.4	Port Arbitration Units (PAUs)	12-11
12.5	Halting of Input and Output FIFOs	12-14
12.5.1	Input FIFO Halt Operation	12-15
12.5.2	Output FIFO Halt Operation	12-15
12.6	Coordinating Communication Ports With the CPU and DMA Coprocessor	12-17
12.7	Token Transfer Operation	12-19
12.8	Word Transfer Operation	12-22
	$\overline{\text{CSTRB}}$ Width Restrictions	12-25
12.9	Synchronizers	12-26
12.10	Module Reset	12-29
12.11	Tips for Using Communication Ports	12-32
13	Timers	13-1
	<i>Describes and discusses operation of the two 'C4x on-chip timers</i>	
13.1	Overview of the Timers	13-2
13.2	Timer Pins	13-4

13.3	Timer Control Registers	13-5
13.3.1	Timer Control Register	13-6
13.3.2	Timer Period Register	13-7
13.3.3	Timer Counter Register	13-8
13.3.4	Boundary Conditions in the Control Registers	13-8
13.4	Timer Pulse Generation	13-9
13.5	Timer Interrupts	13-11
13.5.1	Timer Interrupts and Their Vectors	13-11
13.5.2	Timer Interrupt Operation	13-11
13.5.3	Considerations When Using a Timer Interrupt	13-12
13.6	Selecting CLKSRC and FUNC Values	13-13
13.6.1	CLKSRC = 1 and FUNC = 0	13-13
13.6.2	CLKSRC=1 and FUNC=1	13-13
13.6.3	CLKSRC = 0 and FUNC = 0	13-14
13.6.4	CLKSRC = 0 and FUNC = 1	13-14
13.7	Using TCLKx as General-Purpose I/O Pins	13-15
13.8	Configuring a Timer	13-16
14	Assembly Language Instructions	14-1
	<i>Lists the entire instruction set for the 'C4x</i>	
14.1	Instruction Set	14-2
14.1.1	Load-and-Store Instructions	14-2
14.1.2	Two-Operand Instructions	14-4
14.1.3	Three-Operand Instructions	14-6
14.1.4	Program Control Instructions	14-7
14.1.5	Interlocked Operations Instructions	14-8
14.1.6	Parallel Operations Instructions	14-9
14.1.7	Illegal Instructions	14-11
14.2	Condition Codes and Flags	14-12
14.3	Individual Instruction Descriptions	14-16
14.3.1	Symbols and Abbreviations	14-16
14.3.2	Optional Assembler Syntaxes	14-18
14.3.3	Individual Instruction Descriptions	14-20
A	Glossary	A-1

Figures

2-1	TMS320C4x Block Diagram	2-2
2-2	Central Processing Unit (CPU)	2-5
2-3	Memory Organization	2-12
2-4	'C40 Memory Map	2-14
2-5	'C44 Memory Map	2-15
2-6	Peripheral Memory Map	2-16
2-7	Memory Aliasing ('C44 only)	2-17
2-8	Peripheral Modules	2-22
3-1	Extended-Precision Register Floating-Point Format	3-4
3-2	Extended-Precision Register Integer Format	3-4
3-3	Status Register (ST)	3-5
3-4	DMA Interrupt Enable Register Bit Functions for DMA Unified Mode	3-8
3-5	DMA Interrupt Enable Register Bit Functions for DMA Split Mode	3-10
3-6	Internal Interrupt Enable Register (IIE)	3-12
3-7	Interrupt Flag Register (IIF)	3-14
4-1	'C40 Memory Map	4-3
4-2	'C44 Memory Map	4-4
4-3	Peripheral Memory Map	4-5
4-4	Memory Interface Control Registers	4-6
4-5	Timer Registers	4-7
4-6	Communication Port Memory Map	4-8
4-7	DMA Coprocessor Memory Map	4-9
4-8	Address Partitioning for Cache Control Algorithm	4-10
4-9	Instruction Cache Architecture	4-11
5-1	Short-Integer Format and Sign Extension of Short Integer	5-2
5-2	Single-Precision Integer Format	5-2
5-3	Short Unsigned-Integer Format and Zero Fill	5-3
5-4	Single-Precision Unsigned-Integer Format	5-3
5-5	General Floating-Point Format	5-4
5-6	Short Floating-Point Format	5-5
5-7	Single-Precision Floating-Point Format	5-6
5-8	Extended-Precision Floating-Point Format	5-7
5-9	Short Floating-Point Format Conversion to Single-Precision Floating-Point Format	5-11
5-10	Short Floating-Point Format Conversion to Extended-Precision Floating-Point Format	5-11
5-11	Single-Precision Floating-Point Format Conversion to Extended-Precision Floating-Point Format	5-12

5-12	Extended-Precision Floating-Point Format Conversion to Single-Precision Floating-Point Format	5-12
5-13	IEEE Single-Precision Std. 754 Floating-Point Format	5-13
5-14	'C4x Single-Precision Twos-Complement Floating-Point Format	5-13
5-15	Flowchart for Floating-Point Multiplication	5-20
5-16	Flowchart for Floating-Point Addition	5-24
5-17	Flowchart for NORM Instruction Operation	5-27
5-18	Flowchart for Floating-Point Rounding by the RND Instruction	5-30
5-19	Flowchart for Floating-Point-to-Integer Conversion by FIX Instruction	5-32
5-20	Flowchart for Integer-to-Floating-Point Conversion by FLOAT Instructions	5-33
5-21	RCPF Instruction Algorithm	5-34
5-22	RSQRF Instruction Algorithm	5-37
6-1	Direct Addressing	6-5
6-2	Indirect Addressing Operand Encoding	6-6
6-3	Encoding for 24-Bit PC-Relative Addressing Mode	6-20
6-4	Encoding for General Addressing Modes	6-22
6-5	Encoding for Type 1 Three-Operand Addressing Modes ('C3x and 'C4x)	6-24
6-6	Encoding for Type 2 Three-Operand Addressing Modes ('C4x Only)	6-24
6-7	Encoding for Parallel Multiply With ADD/SUB	6-24
6-8	Encoding for Conditional-Branch Addressing Modes	6-26
6-9	Register Relationships in Circular Addressing	6-28
6-10	Circular Buffer Implementation	6-29
6-11	Circular Addressing Example	6-30
6-12	Data Structure for FIR Filters	6-31
7-1	CALL Response Timing	7-14
7-2	Interrupt-Vector Table (IVT)	7-16
7-3	IIF Register Modification	7-18
7-4	CPU Interrupt Processing	7-19
7-5	Flow of Traps	7-24
7-6	Trap Vector Table (TVT)	7-25
7-7	DMA Interrupt Processing	7-27
7-8	Parallel CPU and DMA Interrupt Processing	7-28
8-1	Pipeline Structure	8-3
8-2	Two-Operand Instruction Word	8-20
8-3	Three-Operand Instruction Word	8-20
8-4	Multiply or CPU Operation With a Parallel Store	8-21
8-5	Two Parallel Stores	8-22
8-6	Parallel Multiplies and Adds	8-23
9-1	Global and Local Memory Interface Control Signals	9-3
9-2	Location of the Memory-Interface Control Registers	9-7
9-3	Fields in the Memory-Interface Control Registers	9-7
9-4	Effects of STRB ACTIVE on Global Memory Bus Memory Map	9-12
9-5	STRBx PAGESIZE Fields Example	9-13
9-6	$\overline{\text{STRB}}$ and $\overline{\text{RDY}}$ Timing	9-16

9-7	Read Same Page, Read Same Page, Write Same Page Sequence	9-18
9-8	Write Same Page, Write Same Page, Read Same Page Sequence	9-19
9-9	Read Same Page, Read Different Page, Read Same Page Sequence	9-20
9-10	Write Same Page, Write Different Page, Write Same Page Sequence	9-21
9-11	Write Same Page, Read Different Page, Write Different Page Sequence	9-22
9-12	Read Different Page, Read Different Page, Write Same Page Sequence	9-23
9-13	Write Different Page, Write Different Page, Read Same Page Sequence	9-24
9-14	Read Same Page, Write Different Page, Read Different Page Sequence	9-25
9-15	Read Same Page, Idle One Cycle, Read Same Page Sequence	9-26
9-16	Write Same Page, Idle One Cycle, Write Different Page Sequence	9-27
9-17	Idle, Read Different Page, Idle Sequence	9-28
9-18	Idle, Write Same Page, Idle Sequence	9-29
9-19	Write Different or Same Page, Idle, Idle Sequence	9-30
9-20	Read Same Page on $\overline{\text{STRB1}}$, $\overline{\text{STRB0}}$, and on $\overline{\text{STRB1}}$ Sequence When STRB SWITCH = 0	9-31
9-21	Read Same Page on $\overline{\text{STRB1}}$, $\overline{\text{STRB0}}$, Read Different Page on $\overline{\text{STRB1}}$ Sequence When STRB SWITCH = 0	9-32
9-22	Read Same Page on $\overline{\text{STRB1}}$, $\overline{\text{STRB0}}$, and on STRB1 Sequence When STRB SWITCH = 1	9-33
9-23	Read Same Page on $\overline{\text{STRB1}}$, $\overline{\text{STRB0}}$, Read Different Page on $\overline{\text{STRB1}}$ Sequence When STRB SWITCH = 1	9-34
9-24	Write Same Page on $\overline{\text{STRB1}}$, $\overline{\text{STRB0}}$, Read Same Page on $\overline{\text{STRB1}}$ Sequence	9-35
9-25	Read With One Wait State	9-36
9-26	Write With One Wait State	9-37
9-27	Using Enable Signals to Put Signal Groups in a High-Impedance State	9-38
9-28	Multiple 'C4x Devices Sharing Global Memory	9-42
9-29	LDII or LDFI External Access	9-45
9-30	LDII or LDFI and STII or STFI External Access	9-46
9-31	SIGI External Access Timing	9-47
9-32	SIGI When $\overline{\text{LOCK}}$ Is Already Low	9-48
9-33	$\overline{\text{IACK}}$ Timing	9-50
10-1	Mode Selection Flow	10-4
10-2	Memory Load Flow	10-6
10-3	Communication-Port Load Mode Flow	10-7
10-4	Circuit for Generation of a Low $\overline{\text{IIOF}}$ Signal for Bootloader Selection	10-19
11-1	DMA Coprocessor Memory Map	11-4
11-2	DMA Channel Control Register	11-8
11-3	DMA Coprocessor Address Generation	11-16
11-4	Transfer Counter Registers	11-17
11-5	Link Pointer Registers	11-18
11-6	Typical Unified-Mode DMA Channel Configuration	11-19
11-7	Typical Split-Mode DMA Configuration	11-21
11-8	Rotating Priority Mode Example of the DMA Coprocessor	11-23
11-9	Rotating Priority DMA Read and Write Sequence Example (Unified Mode)	11-23

11-10	Example of a Priority Wheel	11-24
11-11	Example of a Channel Priority Scheme in Split Mode	11-25
11-12	Service Sequence for Split Mode Priority Example	11-26
11-13	DMA Channel Running in Transfer Mode 102 (Autoinitialization Method 1a)	11-29
11-14	DMA Channel Running in Transfer Mode 102 (Autoinitialization Method 1b)	11-30
11-15	DMA Channel Running in Transfer Mode 112 (Autoinitialization Method 2a)	11-31
11-16	DMA Channel Running in Transfer Mode 112 (Autoinitialization Method 2b)	11-33
11-17	Store New Values of DMA Channel Registers in Memory (SPLIT MODE = 0)	11-35
11-18	Store New Values of DMA Channel Registers in Memory (SPLIT MODE = 1 and Transfer Counter = 0)	11-36
11-19	Store New Values of DMA Channel Registers in Memory (SPLIT MODE = 1 and Auxiliary Transfer Counter = 0)	11-36
11-20	DMA Channel Control Register Bits Modifiable by Autoinitialization in Unified Mode	11-39
11-21	DMA Channel Control Register Bit Modifiable by Autoinitialization of the Primary Channel in Split Mode	11-40
11-22	DMA Channel Control Register Bits That Can Be Modified by Autoinitialization of the Auxiliary Channel in Split Mode	11-40
11-23	Self-Referential Link Pointer	11-41
11-24	Referring to a New Link Pointer	11-41
11-25	DIE Register Bit Functions for DMA Unified Mode	11-44
11-26	DIE Register Bit Functions for DMA Split Mode	11-45
11-27	No DMA Synchronization	11-47
11-28	DMA Source Synchronization	11-48
11-29	DMA Destination Synchronization	11-49
11-30	Unified Mode DMA Source and Destination Synchronization	11-50
11-31	Timing and Number of Cycles for DMA Transfers to On-Chip Destination	11-52
11-32	Timing and Number of Cycles for DMA Transfers to a Local-Bus Destination	11-53
11-33	Timing and Number of Cycles for DMA Transfers to a Global-Bus Destination	11-54
11-34	Unified-Mode DMA Timing for Different Synchronizations	11-55
11-35	Split-Mode DMA Timing for Different Synchronizations	11-56
12-1	Communication Port Block Diagram	12-4
12-2	'C4x Communication-Port Interface-Connection Example	12-5
12-3	Communication-Port Memory Map	12-7
12-4	Communication-Port Control Register (CPCR)	12-8
12-5	Communication-Port Arbitration-Unit State Diagram	12-12
12-6	Token Transfer Operation	12-20
12-7	Word Transfer Operation	12-23
12-8	Type-One Synchronizer Minimum Delay	12-26
12-9	Type-One Synchronizer Maximum Delay	12-26
12-10	Type-Two Synchronizer Minimum Delay	12-27
12-11	Type-Two Synchronizer Maximum Delay	12-27
12-12	Type-Three Synchronizer Minimum Delay	12-27
12-13	Type-Three Synchronizer Maximum Delay	12-28
12-14	Post-Reset State for an Output Port	12-30

12–15	Post-Reset State for an Input Port	12-31
13–1	Timer Block Diagram	13-3
13–2	Memory-Mapped Timer Locations	13-5
13–3	Timer Control Register	13-6
13–4	Timer Pulse Mode and Clock Mode Timing	13-9
13–5	Timer Output Generation Examples	13-10
13–6	Timer Configuration With CLKSRC=1 and FUNC=0	13-13
13–7	Timer Configuration With CLKSRC = 1 and FUNC = 1	13-13
13–8	Timer Configuration With CLKSRC = 0 and FUNC = 0	13-14
13–9	Timer Configuration With CLKSRC = 0 and FUNC = 1	13-14
13–10	TCLK as an Input (I/O = 0)	13-15
13–11	TCLK as an Output (I/O = 1)	13-15
14–1	Status Register	14-13

Tables

1-1	Comparison of 'C40 and 'C44 Features	1-4
2-1	CPU Primary Registers	2-7
3-1	CPU Primary Register File	3-2
3-2	Summary of the CE and CF Bits	3-7
3-3	DMA Channels 0 and 1 (DMA0 and DMA1) Unified Mode Synchronization Interrupts	3-9
3-4	DMA Channels 2 to 5 (DMA2 to DMA5) Unified Mode Synchronization Interrupts	3-9
3-5	DMA Channels 0 and 1 (DMA0 and DMA1) Split-Mode Synchronization Interrupts	3-10
3-6	DMA Channels 2 to 5 (DMA2 to DMA5) Split-Mode Synchronization Interrupts	3-11
3-7	CPU Expansion Registers	3-17
4-1	Combined Effect of the CE and CF Bits	4-13
5-1	Converting IEEE Format to Twos-Complement Floating-Point Format	5-14
5-2	Converting Twos-Complement Floating-Point Format to IEEE Format	5-17
6-1	CPU Register/Assembler Syntax and Function	6-3
6-2	Indirect Addressing	6-7
6-3	Three-Operand Instruction Addressing Modes	6-22
6-4	Index Steps and Bit-Reversed Addressing	6-33
7-1	Repeat-Mode Registers	7-2
7-2	Interrupt Latency	7-21
7-3	Pin States At System Reset	7-29
7-4	RESET Vector Locations	7-35
8-1	One Program Fetch and One Data Access for Maximum Performance	8-17
8-2	One Program Fetch and Two Data Accesses for Maximum Performance	8-18
9-1	Global Memory Interface Signals	9-4
9-2	Global Memory Port Status for STRB0 and STRB1 Accesses	9-5
9-3	Page Size as Defined by STRB0/1 PAGESIZE Bits	9-9
9-4	Address Ranges Specified by STRB ACTIVE Bits	9-10
9-5	Address Ranges Specified by LSTRB ACTIVE Bits	9-11
9-6	Wait-State Generation for Each Value of SWW	9-15
9-7	Interlocked Operations	9-39
10-1	Bootloader Mode Selection Using Pins IIOF(3-0)	10-3
10-2	Structure of Source Program Data Stream	10-8
10-3	Byte-Wide Configured Memory	10-11
10-4	16-Bit Wide Configured Memory	10-14
10-5	32-Bit Wide Configured Memory	10-15
11-1	DMA PRI Bits and CPU/DMA Arbitration Rules	11-12
11-2	TRANSFER MODE (AUX TRANSFER MODE) Field Descriptions	11-12

11-3	SYNC MODE Field Descriptions in Unified Mode	11-13
11-4	SYNC MODE Field Descriptions in Split Mode	11-13
11-5	START (AUX START) Field Descriptions	11-14
11-6	STATUS (AUX STATUS) Field Descriptions	11-14
11-7	DMA PRI Bits and CPU/DMA Arbitration Rules	11-27
11-8	TRANSFER MODE (AUX TRANSFER MODE) Field Descriptions	11-28
11-9	Effect of SYNC MODE and AUTOINIT MODE Bits in Autoinitialization	11-38
11-10	DMA Channels 0 and 1 (DMA0 and DMA1) Unified-Mode Synchronization Interrupts	11-44
11-11	DMA Channels 2 to 5 (DMA2 to DMA5) Unified-Mode Synchronization Interrupts ...	11-45
11-12	DMA Channels 0 and 1 (DMA0 and DMA1) Split-Mode Synchronization Interrupts ...	11-46
11-13	DMA Channels 2 to 5 (DMA2 to DMA5) Split-Mode Synchronization Interrupts	11-46
12-1	Communication-Port Software Reset Address ('C44 and 'C40 ≥ 5.0)	12-10
12-2	PAU State Definitions	12-11
12-3	Summary of Input and Output FIFO Halting	12-14
12-4	Token Transfer Sequence	12-21
12-5	Word Transfer Sequence	12-24
12-6	Communication-Port Signals and Synchronizer Delays	12-28
14-1	Load-and-Store Instructions	14-3
14-2	Two-Operand Instructions	14-4
14-3	Three-Operand Instructions	14-6
14-4	Program Control Instructions	14-7
14-5	Interlocked Operations Instructions	14-8
14-6	Parallel Instructions	14-9
14-7	Output Value Formats	14-12
14-8	Condition Codes and Flags	14-14
14-9	Instruction Symbols	14-17
14-10	CPU Register Symbols	14-21

Examples

4-1	Enabling the Cache	4-13
5-1	Positive Number	5-9
5-2	Negative Number	5-10
5-3	Fractional Number	5-10
5-4	IEEE to 'C4x Conversion Within Block Memory Transfer	5-16
5-5	'C4x to IEEE Conversion Within Block Memory Transfer	5-18
5-6	Floating-Point Multiply (Both Mantissas = -2.0)	5-21
5-7	Floating-Point Multiply (Both Mantissas = 1.5)	5-21
5-8	Floating-Point Multiply (Both Mantissas = 1.0)	5-22
5-9	Floating-Point Multiply Between Positive and Negative Numbers	5-22
5-10	Floating-Point Addition	5-25
5-11	Floating-Point Subtraction	5-25
5-12	Floating-Point Addition With a 32-Bit Shift	5-26
5-13	Floating-Point Addition/Subtraction and Zero	5-26
5-14	NORM Instruction	5-28
5-15	Newton-Raphson Algorithm for Computing the Reciprocal	5-35
5-16	Newton-Raphson Algorithm for Computing the Reciprocal Square Root	5-38
6-1	Direct Addressing	6-5
6-2	Auxiliary Register Indirect	6-9
6-3	Indirect With Predisplacement Add	6-9
6-4	Indirect With Predisplacement Subtract	6-10
6-5	Indirect With Predisplacement Add and Modify	6-10
6-6	Indirect With Predisplacement Subtract and Modify	6-11
6-7	Indirect With Postdisplacement Add and Modify	6-11
6-8	Indirect With Postdisplacement Subtract and Modify	6-12
6-9	Indirect With Postdisplacement Add and Circular Modify	6-12
6-10	Indirect With Postdisplacement Subtract and Circular Modify	6-13
6-11	Indirect With Preindex Add	6-13
6-12	Indirect With Preindex Subtract	6-14
6-13	Indirect With Preindex Add and Modify	6-14
6-14	Indirect With Preindex Subtract and Modify	6-15
6-15	Indirect With Postindex Add and Modify	6-15
6-16	Indirect With Postindex Subtract and Modify	6-16
6-17	Indirect With Postindex Add and Circular Modify	6-16
6-18	Indirect With Postindex Subtract and Circular Modify	6-17
6-19	Indirect With Postindex Add and Bit-Reversed Modify	6-17

6-20	Immediate Addressing	6-18
6-21	PC-Relative Addressing	6-19
6-22	FIR Filter Code Using Circular Addressing	6-31
6-23	Bit-Reversed Addressing Example	6-32
7-1	Repeat-Mode Control Algorithm	7-4
7-2	RPTB Operation	7-4
7-3	Incorrectly Placed Standard Branch	7-6
7-4	Incorrectly Placed Delayed Branch	7-7
7-5	Pipeline Conflict in a RPTB Instruction	7-7
7-6	Incorrectly Placed Delayed Branches	7-10
7-7	Delayed Branch Execution	7-10
8-1	Standard Branch	8-5
8-2	Delayed Branch Without Annul Option	8-6
8-3	Using BcondAF and BcondAT Instructions	8-7
8-4	Write to an AR Followed by an AR for Address Generation	8-8
8-5	A Read of ARs Followed by ARs for Address Generation	8-9
8-6	Program Wait Until CPU Data Access Completes	8-11
8-7	Program Wait Due to Multicycle Access	8-12
8-8	Multicycle Program Memory Fetches	8-12
8-9	Single Store Followed by Two Reads	8-13
8-10	Parallel Store Followed by Single Read	8-14
8-11	Busy External Port	8-15
8-12	Multicycle Data Reads	8-16
8-13	Conditional Calls and Traps	8-16
9-1	Busy-Waiting Loop	9-42
9-2	Task Counter Manipulation	9-42
9-3	Implementation of V(S)	9-43
9-4	Implementation of P(S)	9-43
10-1	Booting a 'C4x Multiprocessor System	10-17
12-2	Communication Port Reset	12-10
13-1	Maximum Frequency Timer Clock Setup	13-16

Introduction

The TMS320C4x devices are 32-bit floating-point digital signal processors optimized for parallel processing. The 'C4x family combines a high performance CPU and DMA controller with up to six communication ports to meet the needs of multiprocessor and I/O-intensive applications. All 'C4x devices are compatible with TI's multi-chip development environment. Each device contains an on-chip analysis module, which supports hardware breakpoints for parallel-processing development and debugging. The 'C4x family is source-code compatible with the TMS320C3x family of floating-point DSPs.

Topic	Page
1.1 TMS320C4x Devices	1-2
1.2 Key Features of the TMS320C4x	1-3
1.3 TMS320C40 and TMS320C44 Device Comparison	1-4

1.1 TMS320C4x Devices

The TMS320C4x family is made up of three different members: the TMS320C40 and the TMS320C44.

1.1.1 The TMS320C40

The TMS320C40 is the original member of the 'C4x family. It features a CPU that can deliver up to 30 MIPS/60 MFLOPS with a maximum I/O bandwidth of 384M bytes/s. The 'C40 has 2K words of on-chip RAM, 128 words of program cache and a bootloader. Two external buses provide an address reach of 4 gigawords of unified memory space. The 'C40 is available in a 325-pin CPGA package.

1.1.2 The TMS320C44

The TMS320C44 is a lower cost version of the 'C40, for parallel processing applications that are more price sensitive. The 'C44 features four communication ports and has an external address reach of 32M words over two external buses. To further reduce cost, the 'C44 comes in a 304-pin PQFP package. The TMS320C44 can deliver up to 30 MIPS/60 MFLOPS performance with a maximum I/O bandwidth of 384M bytes/s. The 'C44 is source-code compatible with the 'C40.

1.2 Key Features of the TMS320C4x

The TMS320C4x has several key features:

- Up to 40 MIPS/80 MFLOPS performance with 488-Mbytes/s I/O capability
 - IEEE floating-point conversion for ease of use
 - Register-based CPU
 - Single-cycle byte and half-word manipulation capabilities
 - Divide and square root support for improved performance
- On-chip memory includes 2K words of SRAM, 128 words of program cache, and bootloader
- Two external buses providing an address reach of up to 4 gigawords
- Two memory-mapped 32-bit timers
- 6 and 12 channel DMA
- Up to six communication ports for multiprocessor communication
- Idle mode for reduced power consumption

1.3 TMS320C40 and TMS320C44 Device Comparison

Table 1–1 shows the major differences in features of the 'C40 and 'C44.

Table 1–1. Comparison of 'C40 and 'C44 Features

Feature	'C40	'C44
External local address bus	31 pins	24 pins
External global address bus	31 pins	24 pins
Address reach	4G × 32	32M × 32
Number of comm ports	6	4
Commport direction pin	no	yes
NMI with bus grant feature	yes (for revisions \geq 5.0)	yes
Individual comm port reset	yes (for revisions \geq 5.0)	yes
Package	325-pin CPGA	304-pin PQFP

Architectural Overview

The 'C4x's high performance is achieved through the precision and wide dynamic range of the floating-point units, on-chip memory, a high degree of parallelism, communication ports, and the DMA coprocessor.

This chapter gives an architectural overview of the 'C4x processor. Figure 2-1 is a block diagram of the 'C4x.

Topic	Page
2.1 Central Processing Unit (CPU)	2-4
2.2 Memory Organization	2-11
2.3 Internal Bus Operation	2-19
2.4 External Bus Operation	2-20
2.5 Interrupts	2-21
2.6 Peripherals	2-22

Figure 2-1. TMS320C4x Block Diagram

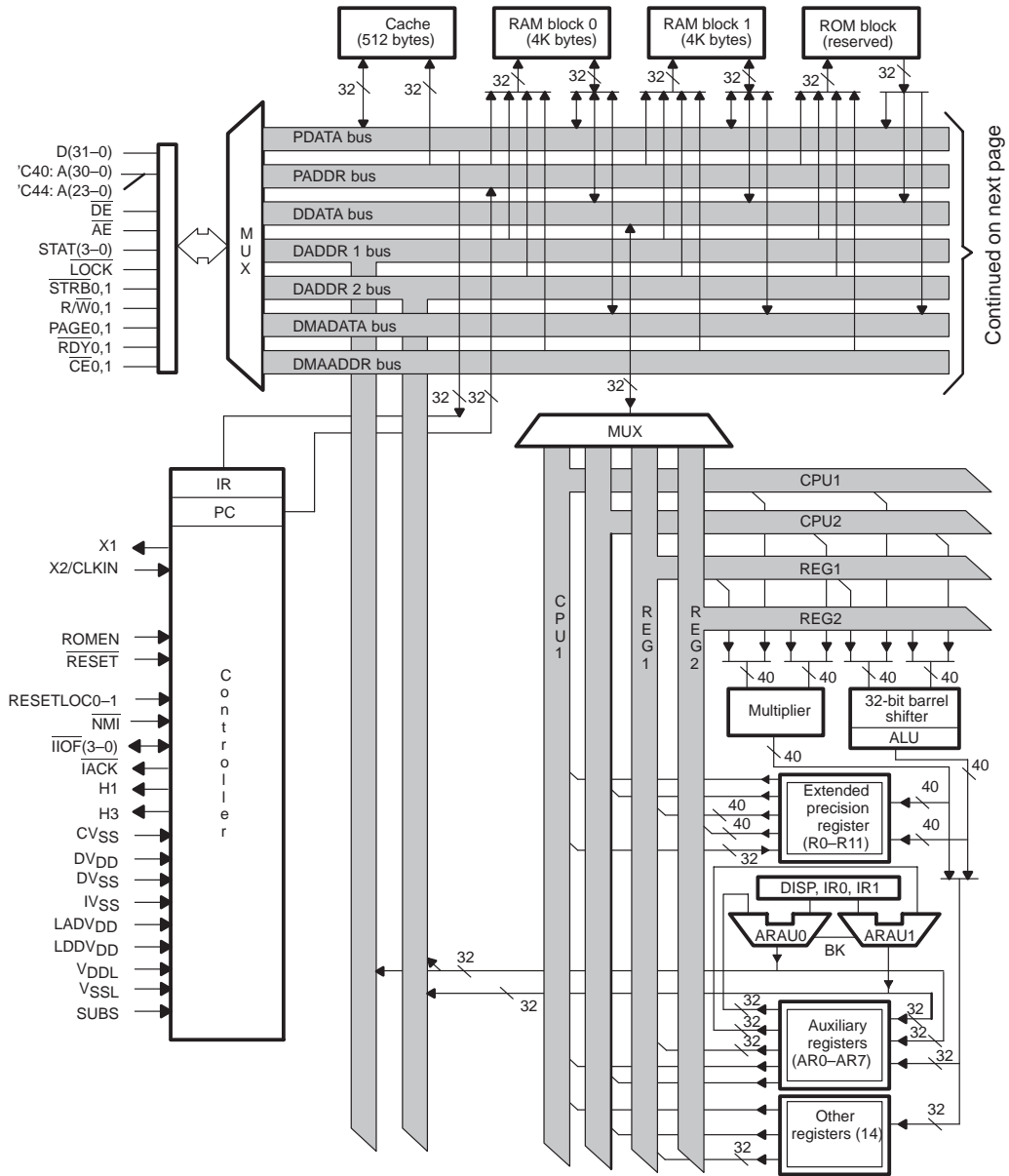

2.1 Central Processing Unit (CPU)

The 'C4x's CPU has a register-based architecture. The CPU consists of the several components:

- Floating-point/integer multiplier
- Arithmetic Logic Unit (ALU)
- 32-bit barrel shifter
- Internal buses (CPU1/CPU2 and REG1/REG2)
- Auxiliary register arithmetic units (ARAUs)
- CPU register file

Figure 2–2 shows the CPU's components.

2.1.1 Floating-Point/Integer Multiplier

The multiplier performs single-cycle multiplications on 32-bit integer and 40-bit floating-point values. The 'C4x implementation of floating-point arithmetic allows for floating-point operations at fixed-point speeds via a 25-ns instruction cycle and a high degree of parallelism. To gain even higher throughput, you can use parallel instructions to perform a multiply and ALU operation in a single cycle.

When the multiplier performs floating-point multiplication, the inputs are 40-bit floating-point numbers, and the result is a 40-bit floating-point number. When the multiplier performs integer multiplication, the input data is 32 bits and yields either the 32 most-significant bits or the 32 least-significant bits of the resulting 64-bit product. See Chapter 5, *Data Formats and Floating-Point Operation*, for detailed information on data formats and floating-point operation.

2.1.2 Arithmetic Logic Unit (ALU) and Internal Buses

The ALU performs single-cycle operations on 32-bit integer, 32-bit logical, and 40-bit floating-point data, including single-cycle integer and floating-point conversions. Results of the ALU are always maintained in 32-bit integer or 40-bit floating-point formats. The barrel shifter is used to shift up to 32 bits left or right in a single cycle.

Four internal buses, CPU1, CPU2, REG1, and REG2, carry two operands from memory and two operands from the register file, thus allowing parallel multiplies and adds/subtracts on four integer or floating-point operands in a single cycle.

Figure 2–2. Central Processing Unit (CPU)

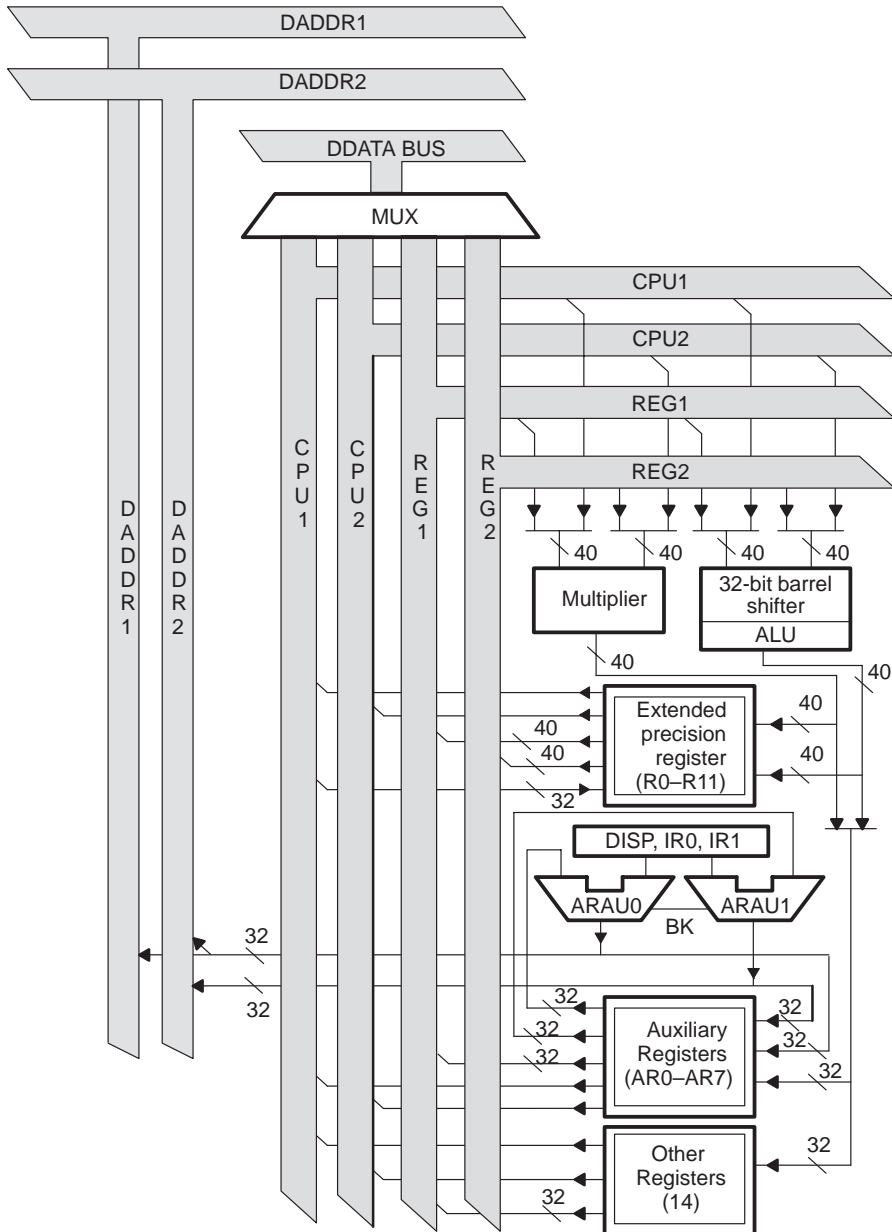

2.1.3 Auxiliary Register Arithmetic Units (ARAUs)

The two auxiliary register arithmetic units (ARAU0 and ARAU1) can generate two addresses in a single cycle. The ARAUs operate in parallel with the multiplier and ALU. They support addressing with displacements, index registers (IR0 and IR1), and circular and bit-reversed addressing. See Chapter 6, *Addressing Modes*, for a description of addressing modes.

2.1.4 CPU Primary Register File

The 'C4x primary register file provides 32 registers in a multiport register file that is tightly coupled to the CPU. Table 2–1 lists register names and functions, followed by the section number and page of each description.

All of the primary register file registers can be operated upon by the multiplier and ALU and can be used as general-purpose registers. However, the registers also have some special functions. For example, the 12 extended-precision registers are especially suited for maintaining floating-point results. The eight auxiliary registers support a variety of indirect addressing modes and can be used as general-purpose 32-bit integer and logical registers. The remaining registers provide system functions such as addressing, stack management, processor status, interrupts, and block repeat. See Chapter 3, *CPU Registers*, for detailed information about CPU registers. See Chapter 6, *Addressing Modes*, for information about register usage in addressing.

The **extended-precision registers (R0–R11)** are capable of storing and supporting operations on 32-bit integer and 40-bit floating-point numbers. Any instruction that assumes that the operands are floating-point numbers uses bits 39–0. If the operands are either signed or unsigned integers, only bits 31–0 are used, and bits 39–32 remain unchanged. This is true for all shift operations. See Chapter 5, *Data Formats and Floating-Point Operation*, for extended-precision register formats of floating-point and integer numbers.

The 32-bit **auxiliary registers (AR0–AR7)** can be accessed by the CPU and modified by the two auxiliary register arithmetic units (ARAUs). The primary function of the auxiliary registers is the generation of 32-bit addresses. They can also be used as loop counters or as 32-bit general-purpose registers that can be modified by the multiplier and ALU. See Chapter 6, *Addressing Modes*, for detailed information and examples of the use of auxiliary registers in addressing.

Table 2–1. CPU Primary Registers

Assembler Syntax	Assigned Function Name	Subsection	Page
R0	Extended-precision register 0	3.1.1	3-3
R1	Extended-precision register 1	3.1.1	3-3
R2	Extended-precision register 2	3.1.1	3-3
R3	Extended-precision register 3	3.1.1	3-3
R4	Extended-precision register 4	3.1.1	3-3
R5	Extended-precision register 5	3.1.1	3-3
R6	Extended-precision register 6	3.1.1	3-3
R7	Extended-precision register 7	3.1.1	3-3
R8	Extended-precision register 8	3.1.1	3-3
R9	Extended-precision register 9	3.1.1	3-3
R10	Extended-precision register 10	3.1.1	3-3
R11	Extended-precision register 11	3.1.1	3-3
AR0	Auxiliary register 0	3.1.2	3-4
AR1	Auxiliary register 1	3.1.2	3-4
AR2	Auxiliary register 2	3.1.2	3-4
AR3	Auxiliary register 3	3.1.2	3-4
AR4	Auxiliary register 4	3.1.2	3-4
AR5	Auxiliary register 5	3.1.2	3-4
AR6	Auxiliary register 6	3.1.2	3-4
AR7	Auxiliary register 7	3.1.2	3-4
DP	Data-page pointer	3.1.3	3-4
IR0	Index register 0	3.1.4	3-4
IR1	Index register 1	3.1.4	3-4
BK	Block-size register	3.1.5	3-5
SP	System stack pointer	3.1.6	3-5

Table 2–1. CPU Primary Registers (Continued)

Assembler Syntax	Assigned Function Name	Subsection	Page
ST	Status register	3.1.7	3-5
DIE	DMA Coprocessor interrupt enable	3.1.8	3-8
IIE	Internal-interrupt enable register	3.1.9	3-11
IIF	IIOF flag register	3.1.10	3-13
RS	Repeat start address	3.1.11	3-16
RE	Repeat end address	3.1.11	3-16
RC	Repeat counter	3.1.11	3-16

The **data page pointer (DP)** is a 32-bit register. The 16 LSBs of the data page pointer are used by the direct addressing mode as a pointer to the page of data being addressed. The 'C4x can address up to 64K pages, each page containing 64K words. Use of the data page pointer is described in subsection 6.3, *Direct Addressing*, on page 6-5.

The 32-bit **index registers** contain the value used by the auxiliary register arithmetic unit (ARAU) to compute an indexed address. See Section 6.4, *Indirect Addressing*, on page 6-6, and Section 6.9, *Bit-Reversed Addressing*, on page 6-32, for more information about the ARAU.

The ARAU uses the 32-bit **block size register (BK)** in circular addressing to specify the data block size. Circular addressing is described in Section 6.8, *Circular Addressing*, on page 6-27.

The **system stack pointer (SP)** is a 32-bit register that contains the address of the top of the system stack. The SP always points to the last element pushed onto the stack. A push performs a preincrement, and a pop performs a post-decrement of the system stack pointer. The SP is manipulated by interrupts, traps, calls, returns, and the PUSH/PUSHF and POP/POPF instructions. See Section 1.4, *System and User Stack Management*, in the *TMS320C4x General-Purpose Applications User's Guide* for information about managing the stacks.

The **status register (ST)** contains global information related to the state of the CPU. Typically, operations set the condition flags of the status register according to whether the result is zero, negative, etc. This includes register load and store operations as well as arithmetic and logical functions. When the status register is loaded, however, a bit-for-bit replacement is performed with the contents of the source operand, regardless of the state of any bits in the source operand. Therefore, following a load, the contents of the status register are identically equal to the contents of the source operand. This allows the status register to be easily saved and restored. See subsection 3.1.7, *Status Register (ST)*, on page 3-5, for definitions of the status register bits.

The **DMA coprocessor interrupt enable register (DIE)** is a 32-bit register containing 2- and 3-bit fields to designate the interrupt synchronization scheme for each of the six DMA channels. It allows each DMA channel to service a corresponding input communication port and output communication port. Also, each DMA channel can be synchronized with external interrupts or the on-chip timers. This register is described in subsection 3.1.8, *DMA Coprocessor Interrupt Enable Register (DIE)*, on page 3-8.

The **CPU internal interrupt enable register (IIE)** is a 32-bit register that enables/disables interrupts for the six communication ports, both timers, and the six DMA coprocessor channels. The IIE is described in subsection 3.1.9, *CPU Interrupt Enable Register (IIE)*, on page 3-11.

The **IIOF flag register (IIF)** controls the function (general-purpose I/O or interrupt) of the four external pins (IIOF0 to IIOF3). It also contains timer/DMA interrupt flags. Subsection 3.1.10, *IIOF Flag Register (IIF)*, on page 3-13, provides further description of this register.

The 32-bit **repeat counter (RC)** register specifies the number of times a block of code is to be repeated when a block repeat is performed. When the processor is operating in the repeat mode, the 32-bit **repeat start address register (RS)** contains the starting address of the block of program memory to be repeated, and the 32-bit **repeat end address register (RE)** contains the ending address of the block to be repeated. Further information about these registers is in subsection 3.1.11, *Block Repeat (RS,RE) and Repeat Count (RC) Registers*, on page 3-16.

The **program counter (PC)** is a 32-bit register containing the address of the next instruction to be fetched. Although the PC is not part of the CPU register file, it is a register that can be modified by instructions that modify the program flow.

2.1.5 CPU Expansion Register File

Besides the CPU primary register file, the expansion register file contains two special registers that act as pointers:

- The IVTP register points to the interrupt-vector table (IVT), which defines vectors for all interrupts.
- The TVTP register points to the trap vector table (TVT), which defines vectors for 512 traps.

These two registers are fully described in Section 3.2, *CPU Expansion Register File* on page 3-17.

2.2 Memory Organization

The total memory reach of the 'C4x is 4G 32-bit words. Program memory (on-chip RAM or ROM and external memory) as well as registers affecting timers, communication ports, and DMA channels are contained within this space. This allows tables, coefficients, program code, and data to be stored in either RAM or ROM. Thus, memory usage is maximized, and memory space allocated as desired.

By manipulating one external pin (ROMEN), you can configure the first one-megaword area of memory (0000 0000h to 000F FFFFh) to address the local address bus or to address the on-chip ROM when you use the bootloader (with remaining space reserved). This capability is further discussed in Section 4.1, *Memory Map*, on page 4-2.

2.2.1 RAM, ROM, and Cache

Figure 2–3 shows how the memory is organized on the 'C4x. RAM blocks 0 and 1 are 4K bytes ($1K \times 32$ bits) each. The ROM block is reserved and contains a bootloader. Each RAM and ROM block is capable of supporting two accesses in a single cycle. The separate program buses, data buses, and DMA buses allow for parallel program fetches, data reads and writes, and DMA operations. For example: the CPU can access two data values in one RAM block and perform an external program fetch in parallel with the DMA coprocessor loading another RAM block, all within a single cycle.

The reserved ROM block (upper right in Figure 2–3) contains a bootloader. This loader supports loading of program and data at reset time. Loading is from 8-, 16-, or 32-bit wide memories or any one of the six communication ports. Chapter 10, *The Bootloader*, explains the bootloader in detail.

A 128×32 -bit instruction cache is provided to store often-repeated sections of code, thus greatly reducing the number of needed off-chip accesses. This allows for code to be stored off-chip in slower, lower-cost memories. By using the cache to execute your program, the external buses are freed for use by the DMA controller or CPU.

For further information about memory and the instruction cache, see Section 4.1, *Memory Organization*, and Section 4.3, *Cache Memory*.

Figure 2–3. Memory Organization

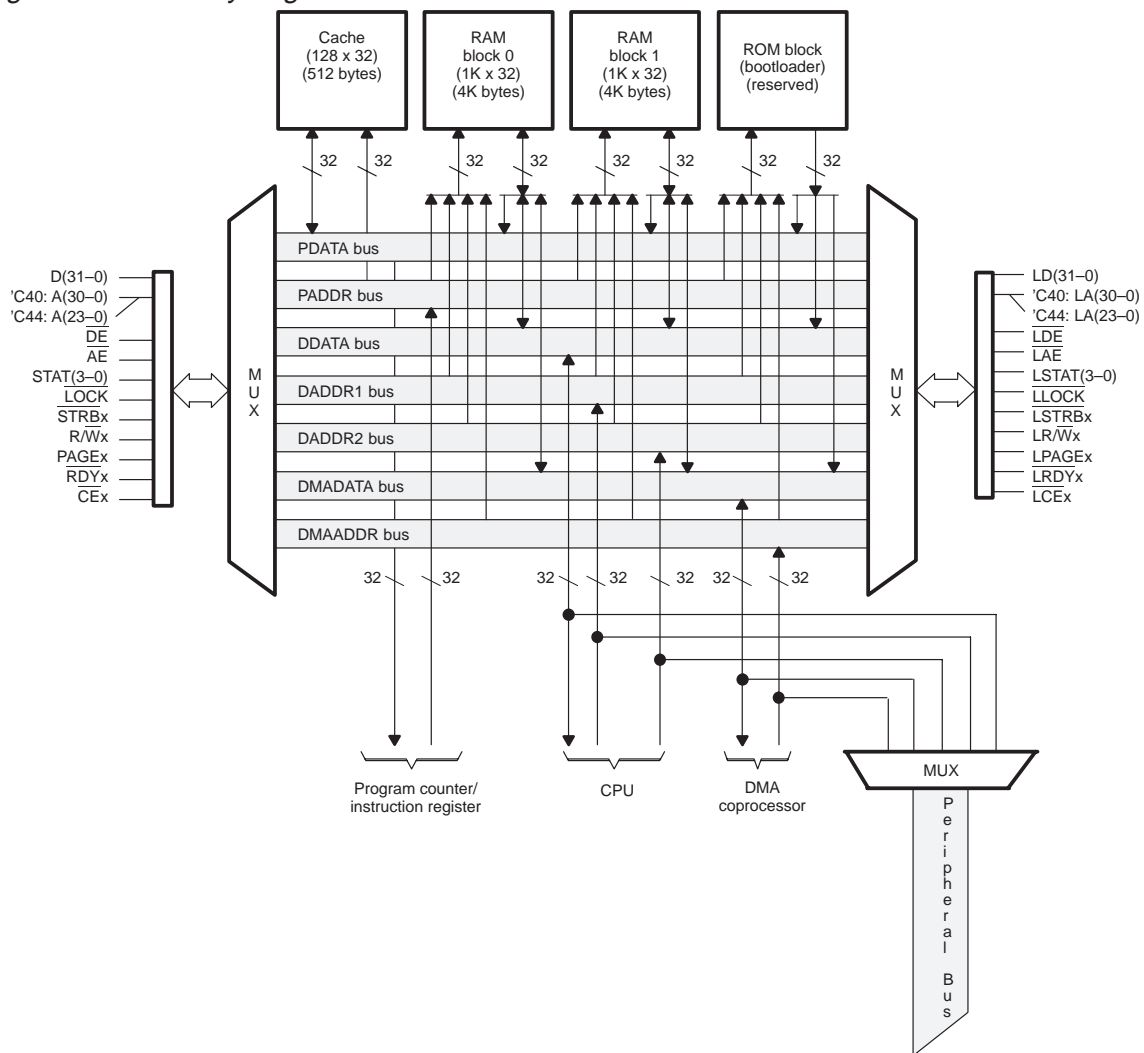

2.2.2 Memory Maps

The memory map for each processor is shown in Figure 2–4 ('C40) and Figure 2–5 ('C44); for each processor, the level at the external pin ROMEN determines whether or not the first megaword of memory addresses the internal ROM or external memory. The maps illustrate the entire address space of the 'C40 and 'C44.

The value of ROMEN affects only the first megaword of memory:

- A 1 at external pin ROMEN causes internal ROM to be enabled at 0000h with the one-megaword space reserved (0000 0000h – 000F FFFFh). This is shown in the right side of the figure.
- A 0 at ROMEN causes addresses 0000 0000h – 000F FFFFh to be accessible on the local bus. This is shown in the left side of the figure.

The rest of the memory map is the same for either level of ROMEN:

- The second megaword of memory is devoted to peripherals (as shown in Figure 2–6).
- The third megaword of memory contains the two 1K-word (4K-byte) blocks of RAM (BLK0 and BLK1 as shown at 002F F800h – 002F FFFFh).
- The rest of the first 2 gigawords (0030 0000h – 7FFF FFFFh) is on the local bus (external).
- The second 2 gigawords (8000 0000h – FFFF FFFFh) are on the global bus (external).

Section 4.1, *Memory Map*, on page 4-2 describes the memory maps in greater detail. Section 9.2, *Memory Interface Signals* on page 9-3, and Section 9.3, *Memory Interface Control Registers* on page 9-6, discuss the local and global interfaces to memory. The peripheral bus map and the vector locations for reset, interrupts, and traps are also explained in those sections.

Caution

Any access to a reserved area in the address space produces unpredictable results. Do not attempt to access reserved areas.

Figure 2–4. 'C40 Memory Map

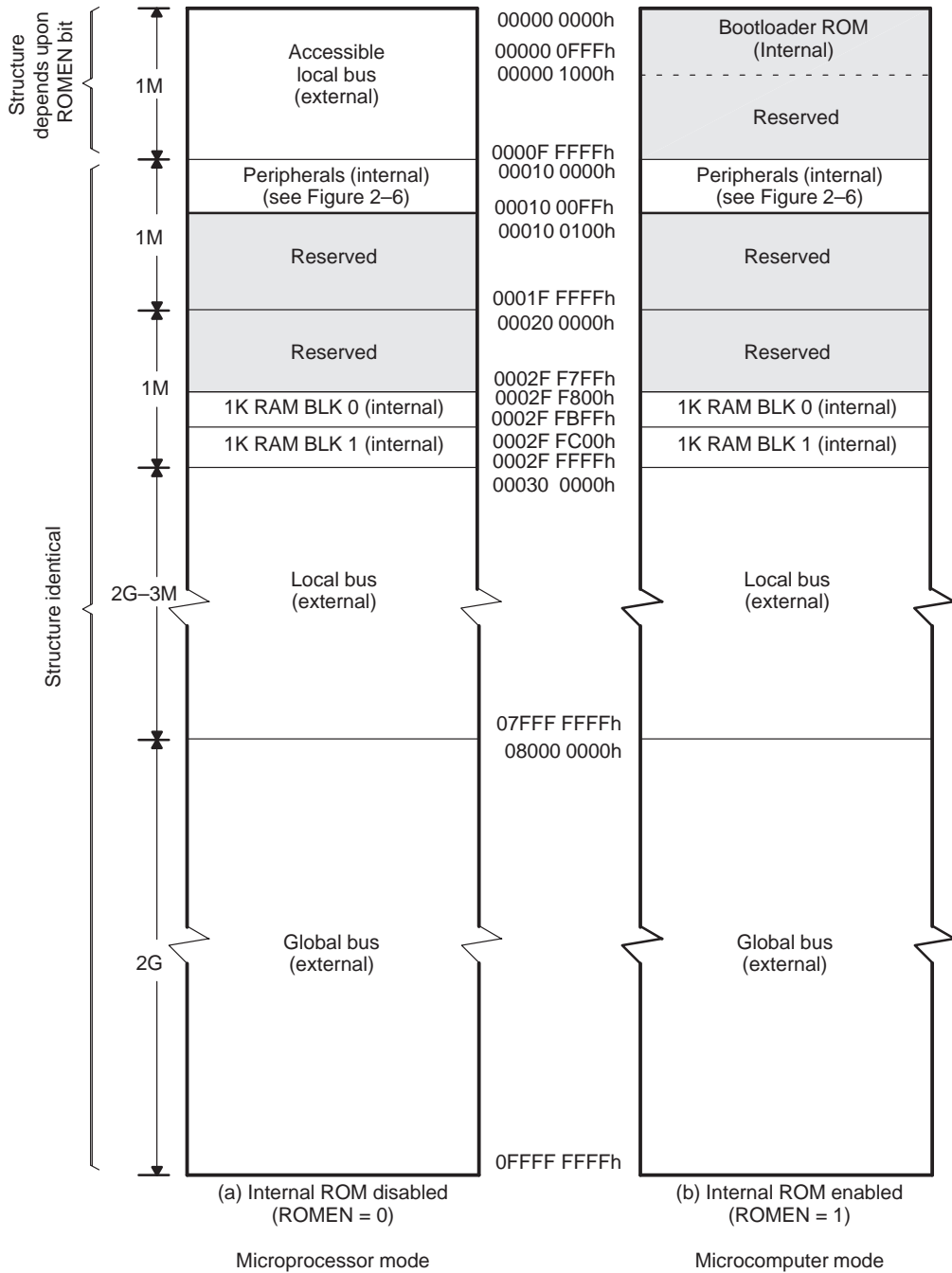

Figure 2-5. 'C44 Memory Map

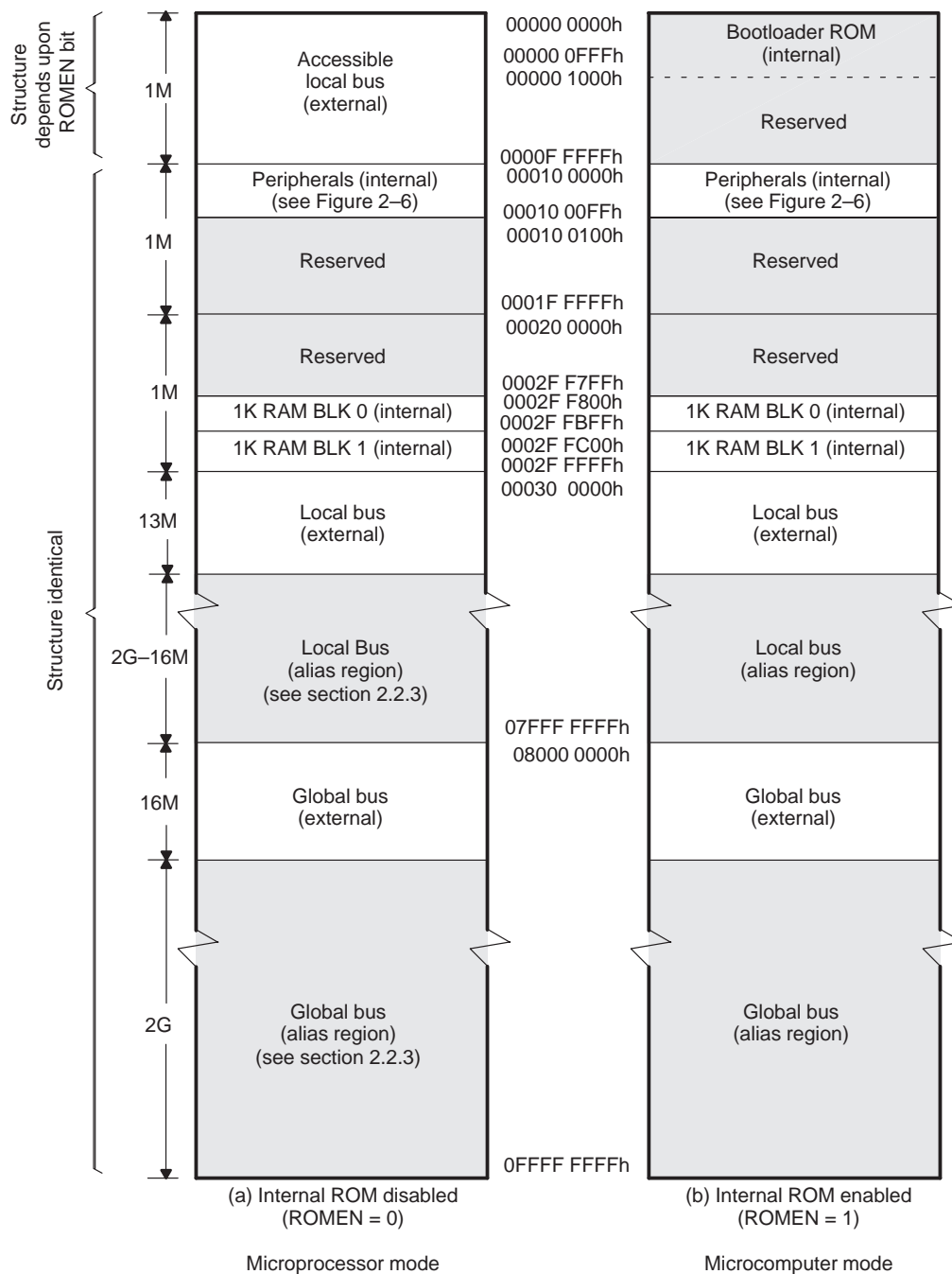

Figure 2–6. Peripheral Memory Map

Address	Peripheral	Described in
0010 0000h 0010 000Fh	Local and global port control (16 words)	Subsection 4.2.1, Figure 4–4, page 4-6
0010 0010h 0010 001Fh	Analysis block registers (16 words)	Subsection 4.2.2.
0010 0020h 0010 002Fh	Timer 0 registers (16 words)	Subsection 4.2.3, Figure 4–5, page 4-7
0010 0030h 0010 003Fh	Timer 1 registers (16 words)	
0010 0040h 0010 004Fh	Communication port 0 (16 words) (‘C40 only)	Subsection 4.2.4, Figure 4–6, page 4-8
0010 0050h 0010 005Fh	Communication port 1 (16 words)	
0010 0060h 0010 006Fh	Communication port 2 (16 words)	
0010 0070h 0010 007Fh	Communication port 3 (16 words) (‘C40 only)	
0010 0080h 0010 008Fh	Communication port 4 (16 words)	
0010 0090h 0010 009Fh	Communication port 5 (16 words)	
0010 00A0h 0010 00AFh	DMA coprocessor channel 0 (16 words)	Subsection 4.2.5, Figure 4–7, page 4-9
0010 00B0h 0010 00BFh	DMA coprocessor channel 1 (16 words)	
0010 00C0h 0010 00CFh	DMA coprocessor channel 2 (16 words)	
0010 00D0h 0010 00DFh	DMA coprocessor channel 3 (16 words)	
0010 00E0h 0010 00EFh	DMA coprocessor channel 4 (16 words)	
0010 00F0h 0010 00FFh	DMA coprocessor channel 5 (16 words)	

2.2.3 Memory Aliasing ('C44 only)

Memory aliasing occurs in the 'C44, since both the global and local ports on that device have 24 pins, instead of the 31 pins on each port in the 'C40. Memory aliasing causes the first 16 M of each address space to be repeated in the memory map. Memory on the local bus occupies, and is aliased, in the first 2 G of address space, and memory on the global bus occupies, and is aliased, in the second 2 G of address space. Figure 2–7 shows the alias regions on the local and global buses.

Figure 2–7. Memory Aliasing ('C44 only)



2.2.4 Memory Addressing Modes

The 'C4x supports a base set of general-purpose instructions as well as arithmetic-intensive instructions that are particularly suited for digital signal processing and other numeric-intensive applications. Refer to Chapter 6, *Addressing Modes*, for detailed information on addressing.

Four groups of addressing modes are provided on the 'C4x. Each group uses two or more of several different addressing types. The following list shows the addressing modes with their addressing types.

- General addressing modes:
 - **Register.** The operand is a CPU register.
 - **Immediate.** The operand is a 16-bit immediate value.
 - **Direct.** The operand is the contents of a 32-bit address (concatenation of 16 bits of the data page pointer and a 16-bit operand).
 - **Indirect.** A 32-bit auxiliary register indicates the address of the operand.
- Three-operand addressing modes:
 - **Register.** (same as for general addressing mode).
 - **Indirect.** (same as for general addressing mode).
 - **Immediate.** The operand is an 8-bit immediate value.
- Parallel addressing modes:
 - **Register.** The operand is an extended-precision register.
 - **Indirect.** (same as for general addressing mode).
- Branch addressing modes:
 - **Register.** (same as for general addressing mode).
 - **PC-relative.** A signed 16-bit displacement *or* a 24-bit displacement is added to the PC.

2.3 Internal Bus Operation

A large portion of the 'C4x's high performance is due to internal busing and parallelism. Separate buses allow for parallel program fetches, data accesses, and DMA accesses:

- **Program buses** PADDR and PDATA
- **Data buses** DADDR1, DADDR2, and DDATA
- **DMA buses** DMAADDR and DMADATA

These buses connect all of the physical spaces (on-chip memory, off-chip memory, and on-chip peripherals) supported by the 'C4x. Figure 2–3 shows these internal buses and their connections to on-chip and off-chip memory blocks.

The program counter (PC) is connected to the 32-bit program address bus (PADDR). The instruction register (IR) is connected to the 32-bit program data bus (PDATA). In this configuration, the buses can fetch a single instruction word every machine cycle.

The 32-bit data address buses (DADDR1 and DADDR2) and the 32-bit data data bus (DDATA) support two data memory accesses every machine cycle. The DDATA bus carries data to the CPU over the CPU1 and CPU2 buses. The CPU1 and CPU2 buses can carry two data memory operands to the multiplier, ALU, and register file every machine cycle. Also internal to the CPU are register buses REG1 and REG2, which can carry two data values from the register file to the multiplier and ALU every machine cycle. Figure 2–2 shows the buses that are internal to the CPU section of the processor.

The DMA controller is supported with a 32-bit address bus (DMAADDR) and a 32-bit data bus (DMADATA). These buses allow the DMA to perform memory accesses in parallel with the memory accesses occurring from the data and program buses.

2.4 External Bus Operation

The 'C4x provides two identical external interfaces: the global memory interface and the local memory interface. Each consists of a 32-bit data bus, a 31-bit ('C40) or 24-bit ('C44) address bus, and two sets of control signals. Both buses can be used to address external program/data memory or I/O space. The buses also have external $\overline{\text{RDY}}$ signals for wait-state generation with wait states inserted under software control. Chapter 9, *External Bus Operation*, covers external bus operation.

For multiple processors to access global memory and share data in a coherent manner, arbitration is necessary. This arbitration (handshaking) is the purpose of the 'C4x's interlocked operations, handled through **interlocked instructions**. For more information about interlocked instructions, see Section 9.7 on page 9-39, *Interlocked Operations*.

2.5 Interrupts

The 'C4x supports four external interrupts ($\overline{\text{IIOF3-0}}$), a number of internal interrupts, a nonmaskable external $\overline{\text{NMI}}$ interrupt, and a nonmaskable external $\overline{\text{RESET}}$ signal, which sets the processor to a known state. The DMA and communication ports have their own internal interrupts. When the CPU responds to the interrupt, the $\overline{\text{IACK}}$ pin can be used to signal an external interrupt acknowledge. Section 7.4, on page 7-15, *Interrupts*, covers RESET and interrupt processing.

2.6 Peripherals

All 'C4x on-chip peripherals are controlled through memory-mapped registers on a dedicated peripheral bus. This peripheral bus is composed of a 32-bit data bus and a 32-bit address bus. This peripheral bus permits straightforward communication to the peripherals. The 'C4x peripherals include two timers and six ('C40) or four ('C44) communication ports. Figure 2–8 shows the peripherals with associated buses and signals.

Figure 2–8. Peripheral Modules

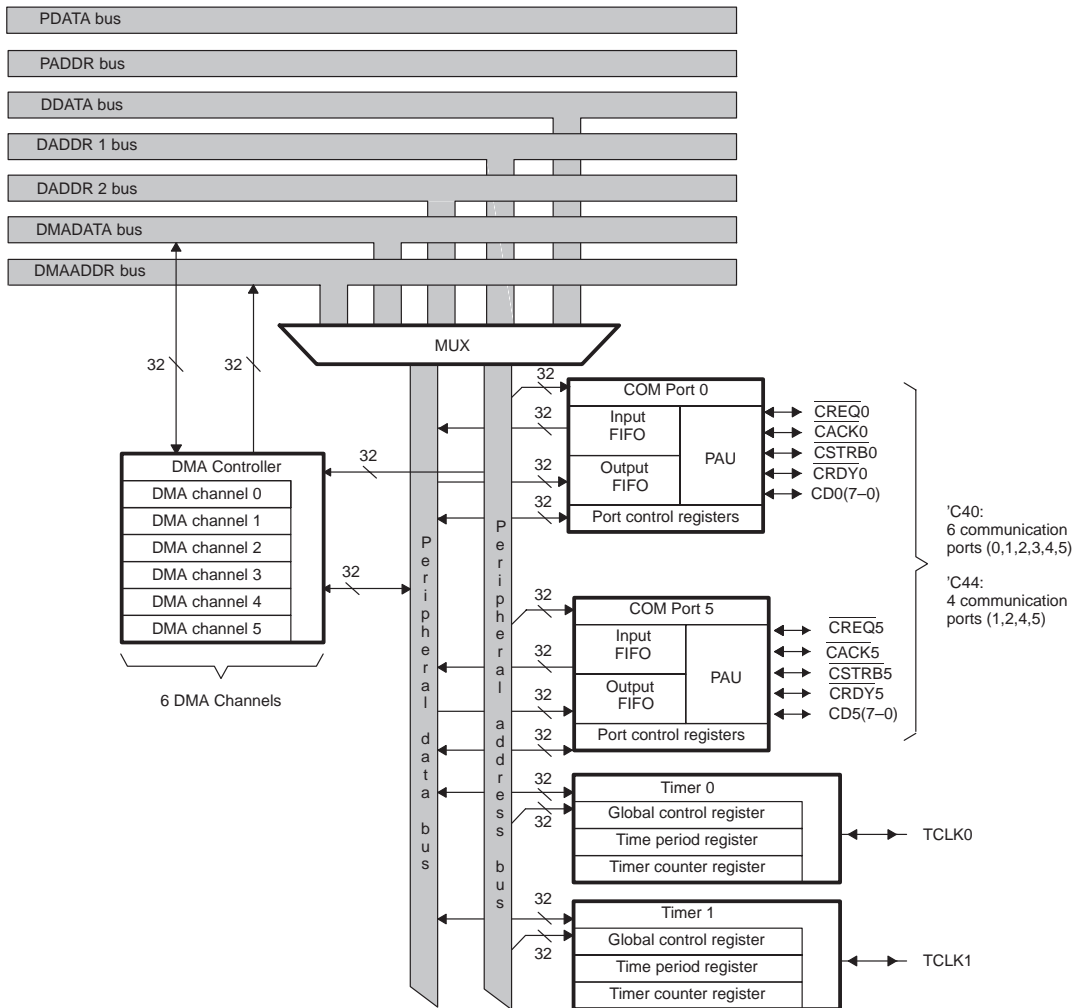

2.6.1 Communication Ports

Six ('C40) or four ('C44) high-speed communication ports provide rapid processor-to-processor communication through each port's dedicated communication interfaces. Coupled with the 'C4x's two memory interfaces (global and local), this allows you to construct a parallel processor system that attains optimum system performance by distributing tasks among several processors. Each 'C4x can pass the results of its work to another 'C4x through a communication port, enabling each 'C4x to continue working. Chapter 12, *Communication Ports*, explains communication port operation in detail.

The communication ports offer several features:

- 160-megabits/s (20-Mbytes or 5-Mwords per second) bidirectional data transfer operations (at 40-ns cycle time)
- Simple processor-to-processor communication via eight data lines and four control lines
- Buffering of all data transfers, both input and output
- Automatic arbitration to ensure communication synchronization
- Synchronization between the CPU or the direct-memory access (DMA) coprocessor and the six communication ports via internal interrupts and internal ready signals.
- Port direction pin (CDIR) to ease interfacing ('C44 only)

2.6.2 Direct Memory Access (DMA) Coprocessor

The six channels of the on-chip DMA coprocessor can read from or write to any location in the memory map without interfering with the operation of the CPU. This allows interfacing to slow external memories and peripherals without reducing throughput to the CPU. The DMA coprocessor contains its own address generators, source and destination registers, and transfer counter. Dedicated DMA address and data buses allow for minimization of conflicts between the CPU and the DMA coprocessor. A DMA operation consists of a block or single-word transfer to or from memory. A key feature of the DMA coprocessor is its ability to automatically reinitialize each channel following a data transfer. See Chapter 11, *The DMA Coprocessor*, for detailed information on the DMA coprocessor.

2.6.3 Timers

The two timer modules are general-purpose 32-bit timer/event counters with two signaling modes and internal or external clocking. They can signal internally to the 'C4x or externally to the outside world at specified intervals, or they can count external events. Each timer has an I/O pin that can be used as an input clock to the timer, as an output signal driven by the timer, or as a general-purpose I/O pin. The timers are described in detail in Chapter 13, *The Timers*.

CPU Registers

The CPU *primary register file* contains 32 registers that can be used as operands by the multiplier and ALU (arithmetic logic unit). The register file includes the auxiliary registers, extended-precision registers, and index registers. These registers support addressing, floating-point/integer operations, stack management, processor status, block repeats, branching, and interrupts.

The CPU *expansion register file* contains two registers — the interrupt vector table pointer (IVTP) and the trap vector table pointer (TVTP).

This chapter describes each of the CPU registers.

Topic	Page
3.1 CPU Primary Register File	3-2
3.2 CPU Expansion Register File	3-17

3.1 CPU Primary Register File

The 'C4x provides 32 registers in a multiport register file that is tightly coupled to the CPU. **The PC (program counter) is not included in the register file.** The contents of the register file are listed in Table 3–1.

Table 3–1. CPU Primary Register File

Register Symbol	Register Machine Value (hex)	Assigned Function Name	Subsection	Page
R0	00	Extended-precision register 0	3.1.1	3-3
R1	01	Extended-precision register 1	3.1.1	3-3
R2	02	Extended-precision register 2	3.1.1	3-3
R3	03	Extended-precision register 3	3.1.1	3-3
R4	04	Extended-precision register 4	3.1.1	3-3
R5	05	Extended-precision register 5	3.1.1	3-3
R6	06	Extended-precision register 6	3.1.1	3-3
R7	07	Extended-precision register 7	3.1.1	3-3
R8	1C	Extended-precision register 8	3.1.1	3-3
R9	1D	Extended-precision register 9	3.1.1	3-3
R10	1E	Extended-precision register 10	3.1.1	3-3
R11	1F	Extended-precision register 11	3.1.1	3-3
AR0	08	Auxiliary register 0	3.1.2	3-4
AR1	09	Auxiliary register 1	3.1.2	3-4
AR2	0A	Auxiliary register 2	3.1.2	3-4
AR3	0B	Auxiliary register 3	3.1.2	3-4
AR4	0C	Auxiliary register 4	3.1.2	3-4
AR5	0D	Auxiliary register 5	3.1.2	3-4
AR6	0E	Auxiliary register 6	3.1.2	3-4
AR7	0F	Auxiliary register 7	3.1.2	3-4
DP	10	Data-page pointer	3.1.3	3-4
IR0	11	Index register 0	3.1.4	3-4
IR1	12	Index register 1	3.1.4	3-4
BK	13	Block-size register	3.1.5	3-5
SP	14	System stack pointer	3.1.6	3-5

Table 3–1. CPU Primary Register File (Continued)

Register Symbol	Register Machine Value (hex)	Assigned Function Name	See Subsection	On Page
ST	15	Status register		
DIE	16	DMA coprocessor interrupt enable	3.1.7 3.1.8	3-5 3-8
IIE	17	Internal-interrupt enable register	3.1.9	3-11
IIF	18	IIOF flag register (IIOF3–0 pins, timers, DMA)	3.1.10	3-13
RS	19	Repeat start address	3.1.11	3-16
RE	1A	Repeat end address	3.1.11	3-16
RC	1B	Repeat counter	3.1.11	3-16

All of these registers can be used both as operands by the multiplier and ALU, and as general-purpose 32-bit registers. However, the registers also perform some special functions. For example, the 12 extended-precision registers maintain extended-precision floating-point results. The eight auxiliary registers support a variety of indirect addressing modes and can be used as general-purpose 32-bit integer and logical registers. The remaining registers provide system functions such as addressing, stack management, processor status, interrupts, and block repeat. Refer to Chapter 6, *Addressing Modes*, for detailed information and examples of how CPU registers are used in addressing.

3.1.1 Extended-Precision Registers (R0–R11)

The 12 extended-precision registers (R0–R11) can store and support operations on 32-bit integer and 40-bit floating-point numbers.

For floating-point numbers, these registers consist of two separate and distinct fields:

- Bits 39–32: store the exponent (*e*) of a floating-point number.
- Bits 31–0: store the mantissa of a floating-point number:
 - Bit 31: sign bit (*s*),
 - Bits 30–0: the fraction (*f*).

Any instruction that assumes that the operands are floating-point numbers uses bits 39–0. Figure 3–1 illustrates the storage of 40-bit floating-point numbers in the extended-precision registers.

Figure 3–1. Extended-Precision Register Floating-Point Format



For integer operations, bits 31–0 of the extended-precision registers contain the integer (signed or unsigned). Any instruction that assumes that the operands are either signed or unsigned integers uses only bits 31–0. Bits 39–32 remain unchanged. This is true for all shift operations. The storage of 32-bit integers in the extended-precision registers is shown in Figure 3–2.

Figure 3–2. Extended-Precision Register Integer Format



3.1.2 Auxiliary Registers (AR0–AR7)

The eight 32-bit auxiliary registers (AR0–AR7) can be accessed by the CPU and modified by the two auxiliary register arithmetic units (ARAUs). The primary function of the auxiliary registers is the generation of 32-bit addresses. However, they can also operate as loop counters in indirect addressing or as 32-bit general-purpose registers that can be modified by the multiplier and ALU. See Chapter 6, *Addressing Modes*, for detailed information and examples of the use of auxiliary registers in addressing.

3.1.3 Data-Page Pointer (DP)

The data-page pointer (DP) is a 32-bit register whose 16 LSBs are used by the direct addressing mode as a pointer to the page of data being addressed. Data pages are 64K words long with a total of 64K (65,536) pages. *Bits 31–16 are reserved; they are always read as zeros and should not be modified by writing to the register.* The DP can be loaded by using the LDP pseudoinstruction or the LDI instruction. Figure 6–1, on page 6-5, describes this register's functions.

3.1.4 Index Registers (IR0, IR1)

The 32-bit index registers (IR0 and IR1) are used by the auxiliary register arithmetic unit (ARAU) for indexing the address. IR0 is also used for bit-reversed addressing. See Chapter 6, *Addressing Modes*, for detailed information and examples of the use of index registers in addressing. Section 6.4, *Indirect Addressing*, on page 6-6, discusses and provides examples of using IR n in indirect addressing. Section 6.9, *Bit-Reversed Addressing*, on page 6-32, describes using IR n with bit-reversed addressing.

3.1.5 Block-Size Register (BK)

The 32-bit block-size register (BK) is used by the ARAU in circular addressing to specify the data block size (see Section 6.8, *Circular Addressing*, on page 6-27, for more information about the use of the BK register).

3.1.6 System Stack Pointer (SP)

The system stack pointer (SP) is a 32-bit register that contains the address of the top of the system stack. The SP always points to the last element pushed onto the stack. The SP is manipulated by interrupts, traps, calls, returns, and the PUSH, PUSHF, POP, and POPF instructions. Pushes and pops of the stack perform preincrement and postdecrement, respectively, on all 32 bits of the SP.

3.1.7 Status Register (ST)

The status register (ST) contains global information about the CPU's state. Typically, load, store, arithmetic, and logical operations affect the ST's condition flags. When the ST is loaded, the contents of the load instruction's source operand replace the ST's current contents, regardless of the state of any bit(s) in the source operand. Therefore, following an ST load, the contents of the ST are identical to the contents of the source operand. This allows the status register to be saved easily and restored. At system reset, 0 is written to the ST; after reset, the CF bit is set to 1. The format of the ST is shown in Figure 3–3. The text following the figure describes each field in the ST.

Figure 3–3. Status Register (ST)

31	30	29	28	27	26	25	24	23	22	21	20	19	18	17	16
xx	xx	xx	xx	xx	xx	xx	xx	xx	xx	xx	xx	NMI bus grant		xx	ANALYSIS
R	R	R	R	R	R	R	R	R	R	R	R	R/W		R	R
15	14	13	12	11	10	9	8	7	6	5	4	3	2	1	0
SC	PGIE	GIE	CC	CE	CF	PCF	RM	OVM	LUF	LV	UF	N	Z	V	C
R/W	R/W	R/W	R/W	R/W	R/W	R/W	R/W	R/W	R/W	R/W	R/W	R/W	R/W	R/W	R/W

NOTE: xx = reserved bit. R = read, W = write.

- C** **Carry-condition flag.**
- V** **Overflow condition flag.**
- Z** **Zero condition flag.**
- N** **Negative condition flag.**
- UF** **Floating-point underflow condition flag.**
- LV** **Latched overflow condition flag.**
- LUF** **Latched floating-point underflow condition flag.**

- OVM** **Overflow mode (OVM) flag.** This flag affects only integer operations.
If OVM = 0, the overflow mode is turned off.
If OVM = 1, integer results overflowing in the positive direction are set to the most positive 32-bit twos-complement number (7FFF FFFFh), and integer results overflowing in the negative direction are set to the most negative 32-bit twos-complement number (8000 0000h).
Note that the functions of bits V and LV are independent of the setting of OVM.
- RM** **Repeat mode (RM) flag.** If RM = 1, the PC is modified in either the repeat-block or repeat-single mode.
- PCF** **Previous state of bit CF.** When a trap executes or an interrupt is taken, the CF bit is set to 1 and the PCF bit is set to the CF bit's previous value.
The RETI and RETID instructions, explained in chapter 14, *Assembly Language Instructions*, copy PCF to the CF bit.
- CF** **Cache freeze (CF).** Enables or disables updating of the cache.
Set CF = 1 to freeze the cache. If CF = 1 and CE = 1, fetches from the cache and cache clearing (CC = 1) are allowed, but modification of the cache contents is not allowed. At reset, this bit is cleared to zero; it is set to 1 after reset.
When CF = 0, the cache is automatically updated by instruction fetches from external memory and cache clearing (CC = 1) is allowed. Traps and interrupts set CF. The RETI and RETID instructions copy the PCF bit to the CF bit.
Table 3–2 summarizes the CE and CF bits.
- CE** **Cache enable (CE).** CE enables or disables the instruction cache.
Set CE = 1 to enable the cache, allowing the cache to be used according to the LRU (least recently used) cache algorithm.
Set CE = 0 to disable the cache, preventing cache modifications and fetches. Cache clearing (CC = 1) is allowed when CE = 0. At reset, 0 is written to CE.
- CC** **Cache clear.** CC = 1 invalidates all entries in the cache (contents not guaranteed). This bit is always cleared after it is written to and thus always read as 0. At reset, 0 is written to this bit. All cache P flags = 0 when cache is cleared.

Table 3–2. Summary of the CE and CF Bits

CE	CF	Effect
0	0	Cache not enabled
0	1	Cache not enabled
1	0	Cache enabled and not frozen
1	1	Cache enabled but frozen (cache read only)

- GIE** **Global interrupt enable.** Enables or disables all maskable interrupts. If GIE = 1, the CPU responds to any enabled interrupts. If GIE = 0, the CPU does not respond to any enabled interrupts. This bit does not affect NMIs. The IDLE, LAT, RETI, RETID, and TRAP instructions affect this bit's value. GIE is cleared to 0 when a trap is executed or an interrupt is taken.
- PGIE** **Previous state of bit GIE.** When a trap executes or an interrupt is taken, bit GIE is cleared to 0. When this occurs, the PGIE bit is set to the GIE bit's value before the trap or interrupt. Note that the RETI*cond* and RETI*condD* instructions copy PGIE to the GIE bit. At reset, this bit is cleared to 0.
- SET COND (SC)** This bit determines how condition flags (ST bits 0–6) are set. If SET COND = 0, condition flags are set if the operation's target is any extended-precision register (R0–R11). This setting makes the 'C4x similar to the 'C3x, regarding condition flag settings. This bit is cleared to 0 at reset. If SET COND = 1, condition flags are set if the target of the operation is **any** register in the primary register files *except* the status register. Condition flags are always set when a CMPF, CMPI, CMPF3, CMPI3, TSTB, or TSTB3 instruction is executed, regardless of the value of SET COND.
- ANALYSIS** This read-only bit is used in analysis mode to provide state information for emulation.
- NMI bus grant** ('C44 and 'C40 revision ≥ 5.0 only)
The NMI bus-grant feature is useful in correcting communication-port errors when used with the communication-port software reset feature. If bit 19 = 1 and bit 18 = 0, an internal peripheral bus-grant signal is forced on the falling edge of $\overline{\text{NMI}}$. If $\overline{\text{NMI}}$ is asserted when the peripheral bus is in a stall condition, the NMI breaks the pending cycle and then jumps to the NMI service routine. A stall condition may occur when writing to a full output FIFO, or when reading from an empty input FIFO.
- xx** Reserved. Value undefined. These bits are read-only.

3.1.8 DMA Coprocessor Interrupt Enable Register (DIE)

The 32-bit DMA interrupt enable register (DIE) is broken into six subfields that determine which interrupts can be used to control the *synchronization* for each of the six DMA coprocessor channels. Synchronization controls when a DMA channel reads or writes. At reset, zeros are written to all register bits.

Each DMA channel looks not only at the DMA synchronous interrupts selected but also at the synchronization mode that the channel is currently using (see Table 11–3). The synchronization mode is specified by the SYNC MODE field in the DMA channel control registers located in the DMA coprocessor.

By using interrupt synchronization, each DMA channel can (for example) service a corresponding communication port. Note that *DMA_i can be synchronized only to signals coming from communication port i (where 0 ≤ i ≤ 5)*. Also, each DMA channel can be synchronized to external interrupts and to the on-chip timers.

3.1.8.1 Unified Mode

Figure 3–4 shows the DMA interrupt enable register for unified mode. Table 3–3 summarizes the interrupt activity for each of the four possible combinations of DMA0 and DMA1 for unified mode. Table 3–4 summarizes the interrupts enabled by three-bit values in DMA2 through DMA5 for unified mode.

Figure 3–4. DMA Interrupt Enable Register Bit Functions for DMA Unified Mode

31	30	29	28	27	26	25	24	23	22	21	20
DMA5 Write			DMA5 Read			DMA4 Write			DMA4 Read		
R/W	R/W	R/W	R/W	R/W	R/W	R/W	R/W	R/W	R/W	R/W	R/W
19	18	17	16	15	14	13	12	11	10	9	8
DMA3 Write			DMA3 Read			DMA2 Write			DMA2 Read		
R/W	R/W	R/W	R/W	R/W	R/W	R/W	R/W	R/W	R/W	R/W	R/W
7	6	5	4	3	2	1	0				
DMA1 Write		DMA1 Read		DMA0 Write		DMA0 Read					
R/W	R/W	R/W	R/W	R/W	R/W	R/W	R/W				

R = Read W = Write

Table 3–3. DMA Channels 0 and 1 (DMA0 and DMA1) Unified Mode Synchronization Interrupts

Bit Value (in DMA0 or DMA1)	Interrupt Enabled at DMA0 or DMA1				Interrupt Source for DMA Synchronization
	DMA0 Read	DMA0 Write	DMA1 Read	DMA1 Write	
0 0†	None	None	None	None	--
0 1‡	ICRDY0	OCRDY0	ICRDY1	OCRDY1	From communication port
1 0	$\overline{\text{IIOF0}}$	$\overline{\text{IIOF1}}$	$\overline{\text{IIOF2}}$	$\overline{\text{IIOF3}}$	From external pins $\overline{\text{IIOF0}}$ – $\overline{\text{IIOF3}}$
1 1	TIM0	TIM0	TIM0	TIM0	From timer TIM0

† DMA channel halts (no read or write operation proceeds) if DMA synchronous transfer is used.

‡ This option is not available for DMA0 and DMA3 in the 'C44.

Table 3–4. DMA Channels 2 to 5 (DMA2 to DMA5) Unified Mode Synchronization Interrupts

Bit Value (in DMA2 to DMA5)	Interrupt Enabled at DMA2–DMA5†		Interrupt Source for DMA Synchronization
	DMAx Read	DMAx Write	
0 0 0‡	None	None	--
0 0 1§	ICRDYx†	OCRDYx†	From communication port
0 1 0	$\overline{\text{IIOF0}}$	$\overline{\text{IIOF0}}$	From external pins $\overline{\text{IIOF0}}$ – $\overline{\text{IIOF3}}$
0 1 1	$\overline{\text{IIOF1}}$	$\overline{\text{IIOF1}}$	
1 0 0	$\overline{\text{IIOF2}}$	$\overline{\text{IIOF2}}$	
1 0 1	$\overline{\text{IIOF3}}$	$\overline{\text{IIOF3}}$	
1 1 0	TIM0	TIM0	From timers TIM0 and TIM1
1 1 1	TIM1	TIM1	

† The x in DMAx is the DMA channel number, which is also the number for the corresponding ICRDYx and OCRDYx interrupts.

For example, an 001₂ in both DMA2 READ and DMA5 WRITE would enable interrupts ICRDY2 and OCRDY5, respectively.

All other viable bit values (010₂ to 111₂) are the same (as shown in the table) for DMA2 through DMA5.

‡ DMA channel halts (no read or write operation proceeds) if DMA synchronous transfer is used.

§ This option is not available for DMA0 and DMA3 in the 'C44.

Note: DMA Coprocessor Uses Signals to Synchronize

The interrupts in Table 3–3 and Table 3–4 (ICRDYx, OCRDYx, TIM0, etc.) are not vectored. The DMA coprocessor uses these as signals to synchronize DMA coprocessor transfers. This process is explained in Section 11.10.

3.1.8.2 Split Mode

Figure 3–5 shows the DMA interrupt enable register for split mode. Table 3–5 summarizes the interrupt activity for each of the four possible combinations of DMA0 and DMA1 for split mode. Table 3–6 summarizes the interrupts enabled by three-bit values in DMA2 through DMA5 for split mode.

Figure 3–5. DMA Interrupt Enable Register Bit Functions for DMA Split Mode

31	30	29	28	27	26	25	24	23	22	21	20
DMA5 Primary Write			DMA5 Auxiliary Read			DMA4 Primary Write			DMA4 Auxiliary Read		
R/W	R/W	R/W	R/W	R/W	R/W	R/W	R/W	R/W	R/W	R/W	R/W
19	18	17	16	15	14	13	12	11	10	9	8
DMA3 Primary Write			DMA3 Auxiliary Read			DMA2 Primary Write			DMA2 Auxiliary Read		
R/W	R/W	R/W	R/W	R/W	R/W	R/W	R/W	R/W	R/W	R/W	R/W
7	6	5	4	3	2	1	0				
DMA1 Primary Write		DMA1 Auxiliary Read		DMA0 Primary Write		DMA0 Auxiliary Read					
R/W	R/W	R/W	R/W	R/W	R/W	R/W	R/W				

R = Read W = Write

Table 3–5. DMA Channels 0 and 1 (DMA0 and DMA1) Split-Mode Synchronization Interrupts

Bit Value (in DMA0 or DMA1)	Interrupt Enabled at DMA0 or DMA1				Interrupt Source for DMA Synchronization
	DMA0 Auxiliary Read	DMA0 Primary Write	DMA1 Auxiliary Read	DMA1 Primary Write	
0 0†	None	None	None	None	--
0 1‡	ICRDY0	OCRDY0	ICRDY1	OCRDY1	From communication port
1 0	$\overline{\text{IIOF0}}$	$\overline{\text{IIOF1}}$	$\overline{\text{IIOF2}}$	$\overline{\text{IIOF3}}$	From external pins $\overline{\text{IIOF0}}$ – $\overline{\text{IIOF3}}$
1 1	TIM0	TIM0	TIM0	TIM0	From timer TIM0

† DMA channel halts (no read or write operation proceeds) if DMA synchronous transfer is used.

‡ This option is not available for DMA0 and DMA3 in the 'C44.

Table 3–6. DMA Channels 2 to 5 (DMA2 to DMA5) Split-Mode Synchronization Interrupts

Bit Value (in DMA2 to DMA5)	Interrupt Enabled at DMA2–DMA5†		Interrupt Source for DMA Synchronization
	DMA x Auxiliary Read†	DMA x Primary Write†	
0 0 0‡	None	None	--
0 0 1§	ICRDY x †	OCRDY x †	From communication port
0 1 0	$\overline{\text{IIOF0}}$	$\overline{\text{IIOF0}}$	From external pins $\overline{\text{IIOF0}}$ – $\overline{\text{IIOF3}}$
0 1 1	$\overline{\text{IIOF1}}$	$\overline{\text{IIOF1}}$	
1 0 0	$\overline{\text{IIOF2}}$	$\overline{\text{IIOF2}}$	
1 0 1	$\overline{\text{IIOF3}}$	$\overline{\text{IIOF3}}$	
1 1 0	TIM0	TIM0	From timers TIM0 and TIM1
1 1 1	TIM1	TIM1	

† The x in DMA x is the DMA channel number, which is also the number for the corresponding ICRDY x and OCRDY x interrupts. For example, an 001₂ in both DMA2 READ and DMA5 WRITE would enable interrupts ICRDY2 and OCRDY5, respectively. All other viable bit values (010₂ to 111₂) are the same (as shown in the table) for DMA2 through DMA5.

‡ DMA channel halts (no read or write operation proceeds) if DMA synchronous transfer is used.

§ This option is not available for DMA0 and DMA3 in the 'C44.

3.1.9 CPU Internal Interrupt Enable Register (IIE)

The 32-bit internal interrupt enable register, shown in Figure 3–6, enables/disables the following interrupts for the CPU:

- Timers 0 and 1
- For communication ports 0–5:
 - Input-buffer full
 - Input-buffer ready
 - Output-buffer ready
 - Output-buffer empty
- DMA coprocessor channels 0–5

Figure 3–6 shows the IIE register bits. A 1 means the corresponding interrupt is enabled; a 0 indicates disabled. At reset, zeros are written to all register bits.

Figure 3–6. Internal Interrupt Enable Register (IIE)

31	30	29	28	27	26	25	24	23	22	21	
ETINT1	EDMA INT5	EDMA INT4	EDMA INT3	EDMA INT2	EDMA INT1	EDMA INT0	EOC-EMPTY5	EOC-RDY5	EIC-RDY5	EIC-FULL5	
R/W	R/W	R/W	R/W	R/W	R/W	R/W	R/W	R/W	R/W	R/W	
20	19	18	17	16	15	14	13	12	11	10	9
EOC EMPTY4	EOC RDY4	EIC RDY4	EIC FULL4	EOC EMPTY3	EOC RDY3	EIC RDY3	EIC FULL3	EOC EMPTY2	EOC RDY2	EIC RDY2	EIC FULL2
R/W	R/W	R/W	R/W	R/W	R/W	R/W	R/W	R/W	R/W	R/W	R/W
8	7	6	5	4	3	2	1	0			
EOC EMPTY1	EOC RDY1	EIC RDY1	EIC FULL1	EOC EMPTY0	EOC RDY0	EIC RDY0	EIC FULL0	ETINT0			
R/W	R/W	R/W	R/W	R/W	R/W	R/W	R/W	R/W			

R = Read, W = Write, R/W = Read/Write

- Notes:**
- 1) In the figure, the shaded boxes are reserved bits in the 'C44. Zero should be written to each of these bits.
 - 2) The fields corresponding to each unit are separated by double lines.

The following are definitions for each of the bits in the IIE.

- EICFULLx** Comm. port x input-buffer full interrupt
- EICRDYx** Comm. port x input-buffer ready interrupt
- EOCRDYx** Comm. port x output-buffer ready interrupt
- EOCEMPTYx** Comm. port x output-buffer empty interrupt
- EDMAINTx** DMA coprocessor channel x interrupt
- ETINT0** Timer 0 interrupt
- ETINT1** Timer 1 interrupt

In each field label, the x represents a communication port number (0 – 5) or a DMA coprocessor channel number (0–5). For example, a 1 in bit 5 causes interrupts to be generated when communication port number 1’s input buffer becomes full. Or, a 1 in bit 26 enables channel 1 of the DMA coprocessor to respond to interrupts. A 1 enables each interrupt; a 0 disables it.

3.1.10 $\overline{\text{IIOF}}$ Flag Register (IIF)

The IIF register controls the external interrupt pins $\overline{\text{IIOF}}(3-0)$. Use it to specify:

- Which $\overline{\text{IIOF}}$ pins are used for general-purpose I/O and which are used for interrupts
- Whether a general-purpose pin is input (read only) or output (read/write)
- Whether an interrupt pin is for edge-triggered or level-triggered interrupts,
- Whether an external interrupt is enabled or disabled

The IIF register also contains timer, DMA and NMI interrupt flags. Figure 3-7 shows the IIF register's bits. The text following the figure explains these bits in detail.

The IIF register bits can be read from or written to under software control. This provides access to the $\overline{\text{IIOF}}_x$ pins, which can be treated as general-purpose I/O or as interrupt pins. For example, if at the IIF register, $\text{FUNC}_x = 0$ (I/O pin) and $\text{TYPE}_x = 1$ (output pin), then by writing into the FLAG_x bit, you can also write to the external pin $\overline{\text{IIOF}}_x$. If $\text{FUNC}_x = 1$ (interrupt pin), writing a 1 to the IIF register FLAG_x bit has the same effect as an incoming interrupt received on the corresponding pin. Consequently, all interrupts can be triggered and/or cleared through software. Since the interrupt bits also can be read from, the interrupt pins can be polled in software when an interrupt-driven interface is not required.

Internal interrupts operate in a similar manner. In the IIF register, the bit corresponding to an internal interrupt (e.g., TINT_0 , TINT_1) can be read from and written to through software. Writing a 1 sets the interrupt latch, and writing a 0 clears it. All internal interrupts are one H1/H3 cycle in length. Modify the IIF by using logic operations (AND, OR, etc.) as shown:

correct
`LDI @MASK, R0
 AND R0, IIF`

incorrect
`LDI IIF, R1
 AND @MASK, R1
 LDI R1, IIF`

Traps and interrupts are described briefly in Section 3.2, *CPU Expansion Register File*, on page 3-17, and in detail in Section 7.4, *Interrupts*, on page 7-15, and Section 7.5, *Traps*, on page 7-24.

Figure 3–7. Interrupt Flag Register (IIF)

31	30	29	28	27	26	25	24
TINT1	DMAINT5	DMAINT4	DMAINT3	DMAINT2	DMAINT1	DMAINT0	TINT0
R/W	R/W	R/W	R/W	R/W	R/W	R/W	R/W
23	22	21	20	19	18	17	16
xx	xx	xx	xx	xx	xx	xx	NMI
R	R	R	R	R	R	R	R
15	14	13	12	11	10	9	8
EIIOF3	FLAG3	TYPE3	FUNC3	EIIOF2	FLAG2	TYPE2	FUNC2
R/W	R/W	R/W	R/W	R/W	R/W	R/W	R/W
7	6	5	4	3	2	1	0
EIIOF1	FLAG1	TYPE1	FUNC1	EIIOF0	FLAG0	TYPE0	FUNC0
R/W	R/W	R/W	R/W	R/W	R/W	R/W	R/W

R = Read, W = Write, R/W = Read/Write

FUNC_x **Mode of pin $\overline{\text{IIOF}}_x$.** If $\text{FUNC}_x = 0$, pin $\overline{\text{IIOF}}_x$ is a *general-purpose I/O (R/W) pin*. If $\text{FUNC}_x = 1$, pin $\overline{\text{IIOF}}_x$ is an *interrupt pin*.

TYPE_x **Type of function for pin $\overline{\text{IIOF}}_x$.**
 If pin $\overline{\text{IIOF}}_x$ is a general-purpose I/O pin ($\text{FUNC}_x = 0$):
 TYPE_x = 0 makes $\overline{\text{IIOF}}_x$ an input pin.
 TYPE_x = 1 makes $\overline{\text{IIOF}}_x$ an output pin
 If pin $\overline{\text{IIOF}}_x$ is an interrupt pin ($\text{FUNC}_x = 1$):
 TYPE_x = 0 makes $\overline{\text{IIOF}}_x$ an edge-triggered latched interrupt,
 TYPE_x = 1 makes $\overline{\text{IIOF}}_x$ a level-triggered unlatched interrupt.

FLAG_x **Flag for pin $\overline{\text{IIOF}}_x$.**
 If pin $\overline{\text{IIOF}}_x$ is a general-purpose input pin ($\text{FUNC}_x = 0$, $\text{TYPE}_x = 0$),
 FLAG_x = the value of pin $\overline{\text{IIOF}}_x$ and is read only.
 If pin $\overline{\text{IIOF}}_x$ is a general-purpose output pin ($\text{FUNC}_x = 0$, $\text{TYPE}_x = 1$),
 FLAG_x = the value on pin $\overline{\text{IIOF}}_x$ and is R/W.
 If pin $\overline{\text{IIOF}}_x$ is an interrupt pin ($\text{FUNC}_x = 1$):
 FLAG_x = 0 if interrupt is not asserted.
 FLAG_x = 1 if interrupt is asserted.
 If 0 (zero) is written to FLAG_x, the corresponding interrupt is cleared unless an interrupt is on the same pin; in that case, the interrupt will remain set.

EIIFO_x **Disable/enable external interrupt.**
 EIIFO_x = 0 disables external interrupts at pin $\overline{\text{IIOF}}_x$.
 EIIFO_x = 1 enables external interrupts at pin $\overline{\text{IIOF}}_x$.

NMI	<p>Nonmaskable Interrupt flag (NMI). The NMI interrupt (on the external $\overline{\text{NMI}}$ pin) behaves like other interrupts, except that it cannot be masked (disabled) by the GIE bit (ST bit 13) or by writing to the NMI bit. It is temporarily masked during delayed branches and multicycle CPU operations. At reset, this bit is cleared. An asserted interrupt is cleared only by servicing the interrupt. NMI is a negative-going, edge-triggered, latched interrupt. It is read-only.</p> <p>Reading NMI as 0 indicates that the interrupt is not asserted.</p> <p>Reading NMI as 1 indicates that the interrupt is asserted.</p>
Reserved	Reserved; read as zeros.
TINT0	Timer interrupt flags 0 and 1.
TINT1	<p>Reading TINTx as 0 indicates that the timer interrupt is not asserted. Reading TINTx as 1 indicates that the timer interrupt is asserted. A zero written to this bit clears the interrupt unless the interrupt is asserted at the same time; in that case, the interrupt will be shown as asserted.</p>
DMAINTx	<p>Interrupt flag for DMA coprocessor channels 0 to 5. Reading DMAINTx as 0 indicates that the channel interrupt is not asserted. Reading DMAINTx as 1 indicates that the channel interrupt is asserted. A zero written to this bit clears the interrupt unless the interrupt is asserted at the same time; in that case, the interrupt is shown as asserted.</p>

Notes:

- 1) Shaded IIF bits 0, 1, 2, 3 apply to pin $\overline{\text{IIOF0}}$; shaded IIF bits 4, 5, 6, 7 apply to $\overline{\text{IIOF1}}$, etc.
 - 2) The x represents the corresponding $\overline{\text{IIOF}}$ interrupt pin ($\overline{\text{IIOF0-3}}$)
-

3.1.11 Block-Repeat (RS, RE) and Repeat-Count (RC) Registers

The 32-bit repeat start address register (RS) contains the starting address of the block of program memory to be repeated when the CPU is operating in the repeat mode.

The 32-bit repeat end address register (RE) contains the ending address of the block of program memory to be repeated when the CPU is operating in the repeat mode.

Note:

If $RE < RS$, the block of program memory is not repeated, and the code does not loop backwards. However, the ST(RM) bit remains set to 1.

The repeat-count register (RC) is a 32-bit register that specifies the number of times a block of code is to be repeated when a block repeat is performed. If RC contains the number n , the loop is executed $n + 1$ times.

3.1.12 Program Counter (PC)

The program counter (PC) is a 32-bit register containing the address of the next instruction to fetch. While the program counter is not part of the CPU register file, it can be modified by the same instructions that modify the program flow.

3.1.13 Reserved Bits and Compatibility

To retain compatibility with future members of the 'C4x family of microprocessors, reserved bits that are read as zero must be written as zero. Reserved bits that have an undefined value **must not** have their current value modified. In other cases, maintain the reserved bits as specified.

3.2 CPU Expansion Register File

This expansion register file contains two special control registers:

- Interrupt-vector table pointer (IVTP)
- Trap-vector table pointer (TVTP)

Table 3–7. CPU Expansion Registers

Assembler Syntax	Register Machine Value (Hex)	Function Name
IVTP	00	Interrupt-vector table pointer. Points to start of the interrupt-vector table.
TVTP	01	Trap-vector table pointer. Points to start of the trap-vector table.

Use the **LDEP instruction** to load (copy) an expansion register to a primary register (e.g., to any of the auxiliary registers AR0–AR7; see Table 3–1 on page 3-2). For example:

```
LDEP    IVTP,AR5 ; IVTP contents to AR5
```

Likewise, use the **LDPE instruction** to load (copy) a primary register to an expansion register. Neither of these instructions affects the status register condition flags.

```
LDPE    AR5,IVTP ; AR5 contents to IVTP
```

Note that both the interrupt-vector table and the trap-vector table are required to lie on a 512-word boundary; thus, the nine least significant bits of these pointers are zeros (i.e., $10\ 0000\ 0000_2 = 512 = 200h$). Write only zeros to these bits (though the register forces these to zeros).

The 32-bit **IVTP register** points to (is essentially the base address for) the interrupt-vector table (IVT) in memory.

The 32-bit **TVTP register** is essentially the base address for the trap-vector table (TVT) in memory. This table contains the vectors for the TRAP instruction's 512-trap addresses (TRAP0–TRAP511).

The interrupt and trap vector tables can share the same 512-byte space in memory. In this configuration, you can place trap vectors where there are no interrupt vectors. For example, since interrupt vector 02Ch is unused, you could place a trap vector at IVTP + 02Ch (which is also TVTP + 02Ch if the tables overlap) and then call that trap by specifying 02Ch in the TRAP instruction.

At reset, IVTP and TVTP are both set to zero.

Memory and the Instruction Cache

The 'C40 accesses a total memory space of 4G 32-bit words (16G bytes) of program, data, and I/O space; the 'C44 accesses a total memory space of 32M 32-bit words (128M bytes).

Two internal RAM blocks of 1K × 32 bits each (4K bytes) and an internal ROM block containing a bootloader permit two accesses per block in a single cycle.

A 128 × 32-bit instruction cache allows code to be stored off-chip in slower, lower-cost memories without degrading performance. The cache also speeds data fetches to the same physical space as the program because it does not burden the bus with program instruction fetches.

This chapter describes the memory maps and the instruction cache.

Topic	Page
4.1 Memory Map	4-2
4.2 Peripheral Bus Memory Map	4-5
4.3 Instruction Cache	4-10

4.1 Memory Map

The 'C4x memory space of 4 gigawords ($4\text{G} \times 32$ bits where $1\text{G} = 2^{30}$) is shown in the memory maps in Figure 4–1 and Figure 4–2. The contents of the first segment of address space, at 0000 0000h to 000F FFFFh, is selected by the value of the ROM enable (ROMEN) pin:

- ❑ **ROMEN = 1.** Addresses 0000 0000h–0000 0FFFh are an on-chip ROM block (reserved for bootloader operations), and addresses 0000 1000h–000F FFFFh are reserved.
- ❑ **ROMEN = 0.** The on-chip (reserved) ROM is disabled, and addresses 0000 0000h–000F FFFFh are mapped to the local bus.

Memory starting at 0010 0000h is not affected by ROMEN. The following is a general summary of address ranges:

- ❑ **0000 0000h–000F FFFFh:** Can be local bus or on-chip (reserved) ROM, depending on the value of ROMEN. If ROMEN=0, these addresses are mapped to the local bus. If ROMEN=1, these addresses are mapped to the on-chip ROM.
 - ❑ **0010 0000h–0010 00FFh:** Internal peripherals (DMA coprocessor, communications ports, timers, etc.).
 - ❑ **0010 0100h–002F F7FFh:** Reserved.
 - ❑ **002F F800h–002F FBFFh:** 1K RAM Block 0.
 - ❑ **002F FC00h–002F FFFFh:** 1K RAM Block 1.
 - ❑ **0030 0000h–7FFF FFFFh:** Local bus. These addresses are mapped to the local bus.
 - ❑ **8000 0000h–0FFFF FFFFh:** Global bus. These addresses are mapped to the global bus.
- } Instructions cannot be loaded from these 2 areas.

CPU data accesses and DMA accesses can be made from any unreserved part of the 'C4x memory map. Instruction fetches can take place from any unreserved area of the 'C4x memory map, except from the peripheral space (addresses 0010 0000h–0010 00FFh).

Note:

The 'C4x internal ROM is generally reserved for TI internal use only. However, for high-volume applications, you can request that TI install your code in the internal ROM.

Figure 4–1. 'C40 Memory Map

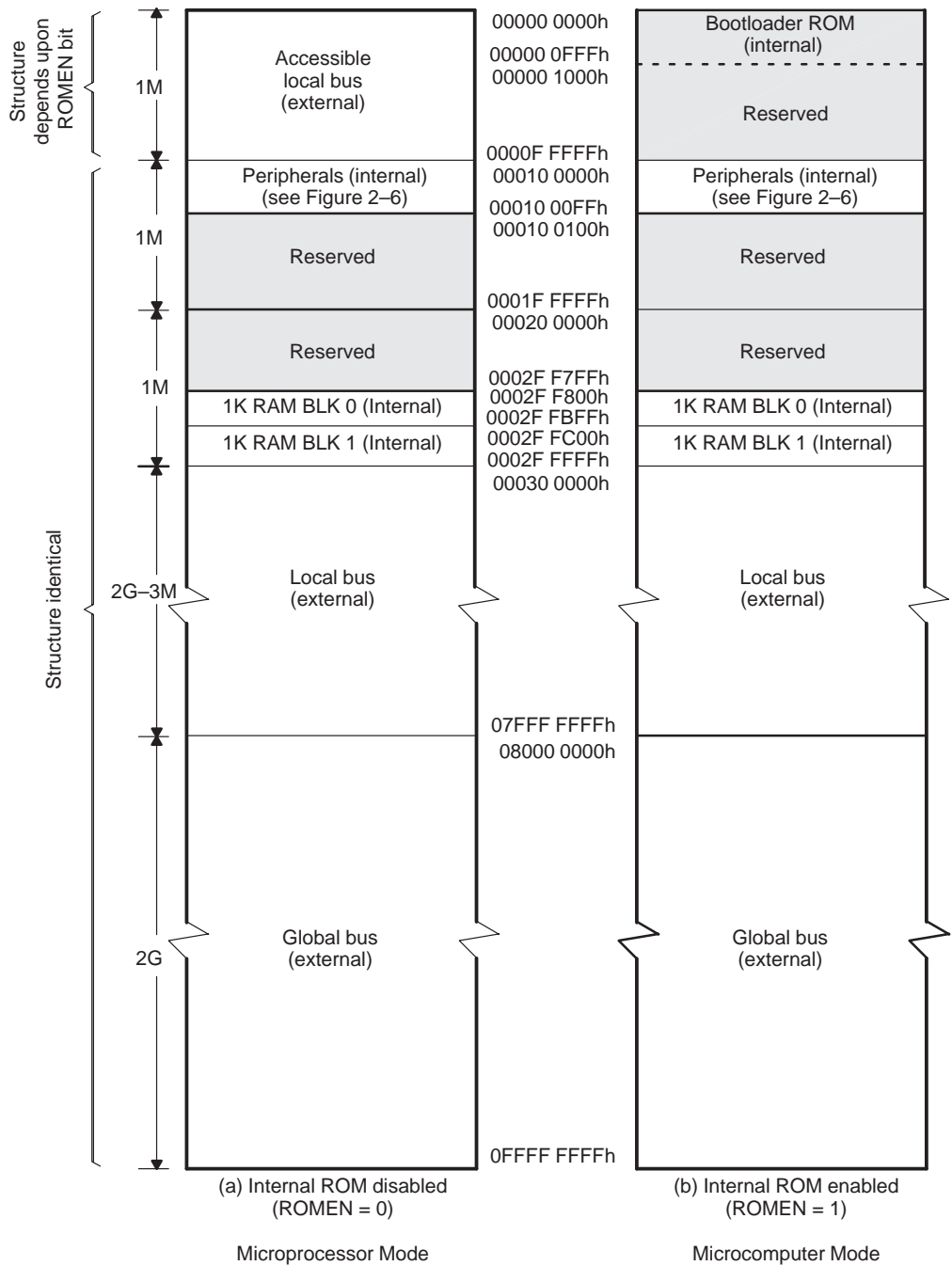
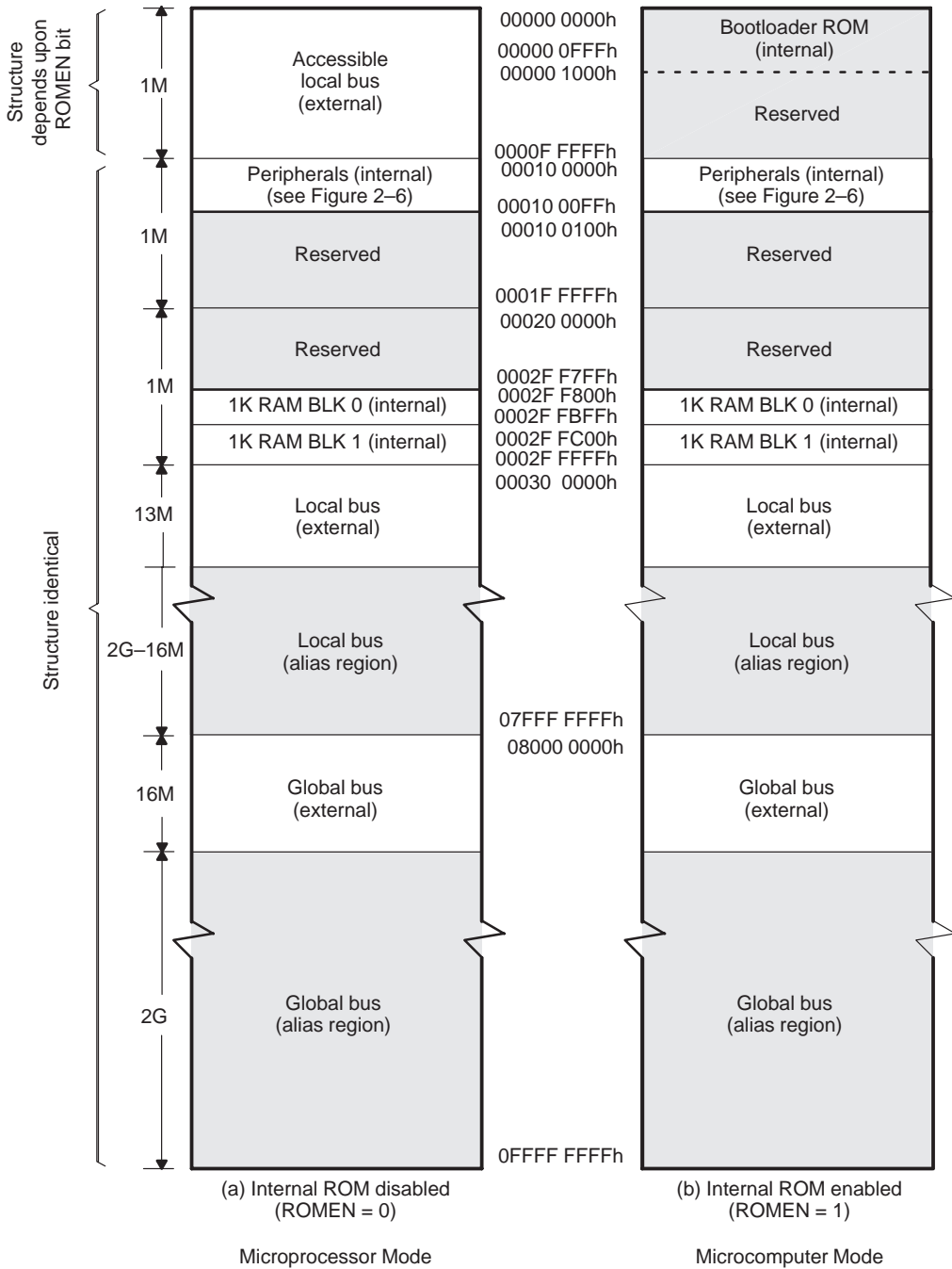

Figure 4–2. 'C44 Memory Map



4.2 Peripheral Bus Memory Map

The peripheral bus memory map resides in addresses 0010 0000h–0010 00FFh. Each peripheral requires a 16-word area. Figure 4–3 shows the locations of registers for each peripheral in the memory map.

Figure 4–3. Peripheral Memory Map

0010 0000h 0010 000Fh	Local and Global Port Control (16 words) (See subsection 4.2.1 and Figure 4–4)
0010 0010h 0010 001Fh	Analysis Module Block Registers (16 words) (See subsection 4.2.2)
0010 0020h 0010 002Fh	Timer 0 Registers (16 words) (See subsection 4.2.3 and Figure 4–5)
0010 0030h 0010 003Fh	Timer 1 Registers (16 words) (See subsection 4.2.3 and Figure 4–5)
0010 0040h 0010 004Fh	Communication Port 0 (16 words) ('C40 only) (See subsection 4.2.4 and Figure 4–5)
0010 0050h 0010 005Fh	Communication Port 1 (16 words) (See subsection 4.2.4 and Figure 4–5)
0010 0060h 0010 006Fh	Communication Port 2 (16 words) (See subsection 4.2.4 and Figure 4–5)
0010 0070h 0010 007Fh	Communication Port 3 (16 words) ('C40 only) (See subsection 4.2.4 and Figure 4–5)
0010 0080h 0010 008Fh	Communication Port 4 (16 words) (See subsection 4.2.4 and Figure 4–5)
0010 0090h 0010 009Fh	Communication Port 5 (16 words) (See subsection 4.2.4 and Figure 4–5)
0010 00A0h 0010 00AFh	DMA Coprocessor Channel 0 (16 words) (See subsection 4.2.5 and Figure 4–6)
0010 00B0h 0010 00BFh	DMA Coprocessor Channel 1 (16 words) (See subsection 4.2.5 and Figure 4–6)
0010 00C0h 0010 00CFh	DMA Coprocessor Channel 2 (16 words) (See subsection 4.2.5 and Figure 4–6)
0010 00D0h 0010 00DFh	DMA Coprocessor Channel 3 (16 words) (See subsection 4.2.5 and Figure 4–6)
0010 00E0h 0010 00EFh	DMA Coprocessor Channel 4 (16 words) (See subsection 4.2.5 and Figure 4–6)
0010 00F0h 0010 00FFh	DMA Coprocessor Channel 5 (16 words) (See subsection 4.2.5 and Figure 4–6)

4.2.1 Local and Global Memory Interface Control Registers

These registers control the local and global memory interfaces. They occupy the first 16-word block of the peripheral bus memory map, shown in Figure 4–3. The registers themselves are shown in Figure 4–4. Chapter 9, *External Bus Operation*, covers the operation of these registers.

These registers define several settings:

- The page sizes used for the two strobes of each port
- Address ranges over which the strobes are active
- Wait states
- Other similar operations that compose the memory interfaces

Figure 4–4. Memory Interface Control Registers

0010 0000h	Global Memory Interface Control Register
0010 0001h	Reserved
0010 0003h	Reserved
0010 0004h	Local Memory Interface Control Register
0010 0005h	Reserved
0010 000Fh	Reserved

4.2.2 Analysis Module Registers

The second lowest 16-word block in the peripheral bus memory map, as shown in Figure 4–3, contains part of the analysis module registers. These registers are reserved for emulation functions. The *TMS320C4x C Source Debugger User’s Guide (literature number SPRU054)* describes the analysis module user interface provided by the 'C4x debugger.

4.2.3 Timer Registers

This group of registers occupies the 0010 0020h–0010 003Fh range in the peripheral bus memory map shown in Figure 4–3, on page 4-5. Timers and their registers are covered in detail in Chapter 13, *Timers*.

Figure 4–5. Timer Registers

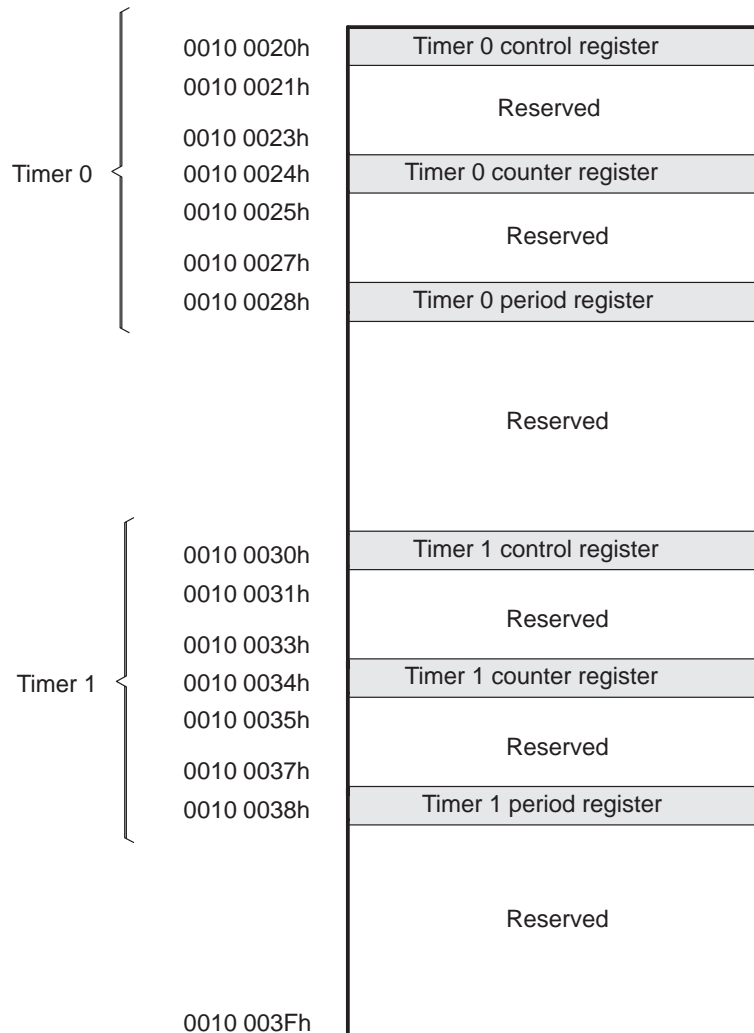

4.2.4 Communication Port Memory Map

Figure 4–6 illustrates the communication-port control registers (CPCR) and input and output FIFO buffers. This is the central group of registers in the peripheral bus memory map shown in Figure 4–4, on page 4-6. These registers are described in more detail in Chapter 12, *Communication Ports*.

Figure 4–6. Communication Port Memory Map

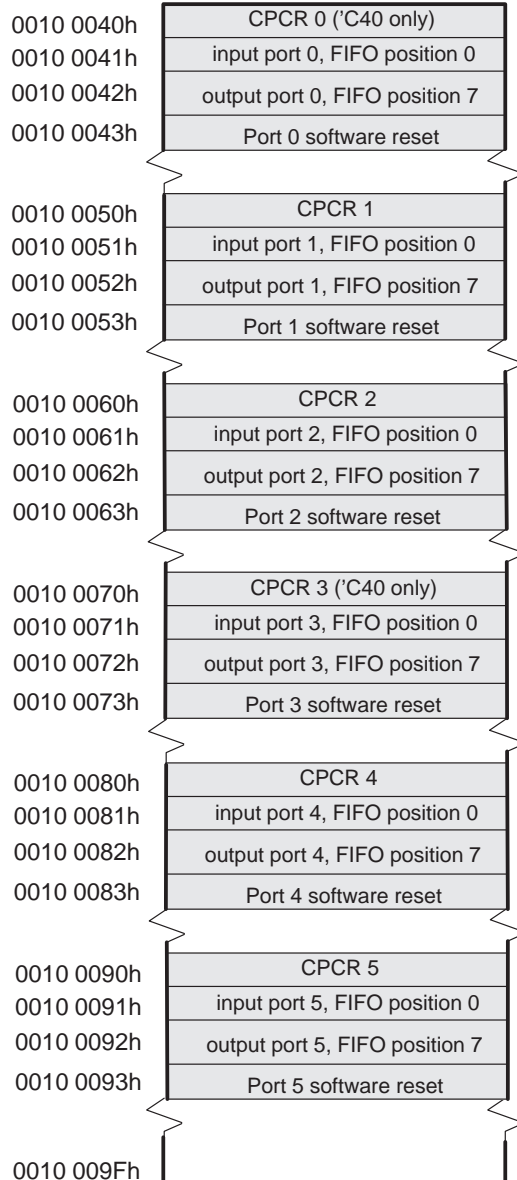

4.2.5 DMA Coprocessor Registers

The DMA registers (shown in Figure 4–7) are the bottom block of registers in the peripheral bus memory map (Figure 4–3 on page 4-5). These registers are described in Chapter 11, *The DMA Coprocessor*.

Figure 4–7. DMA Coprocessor Memory Map

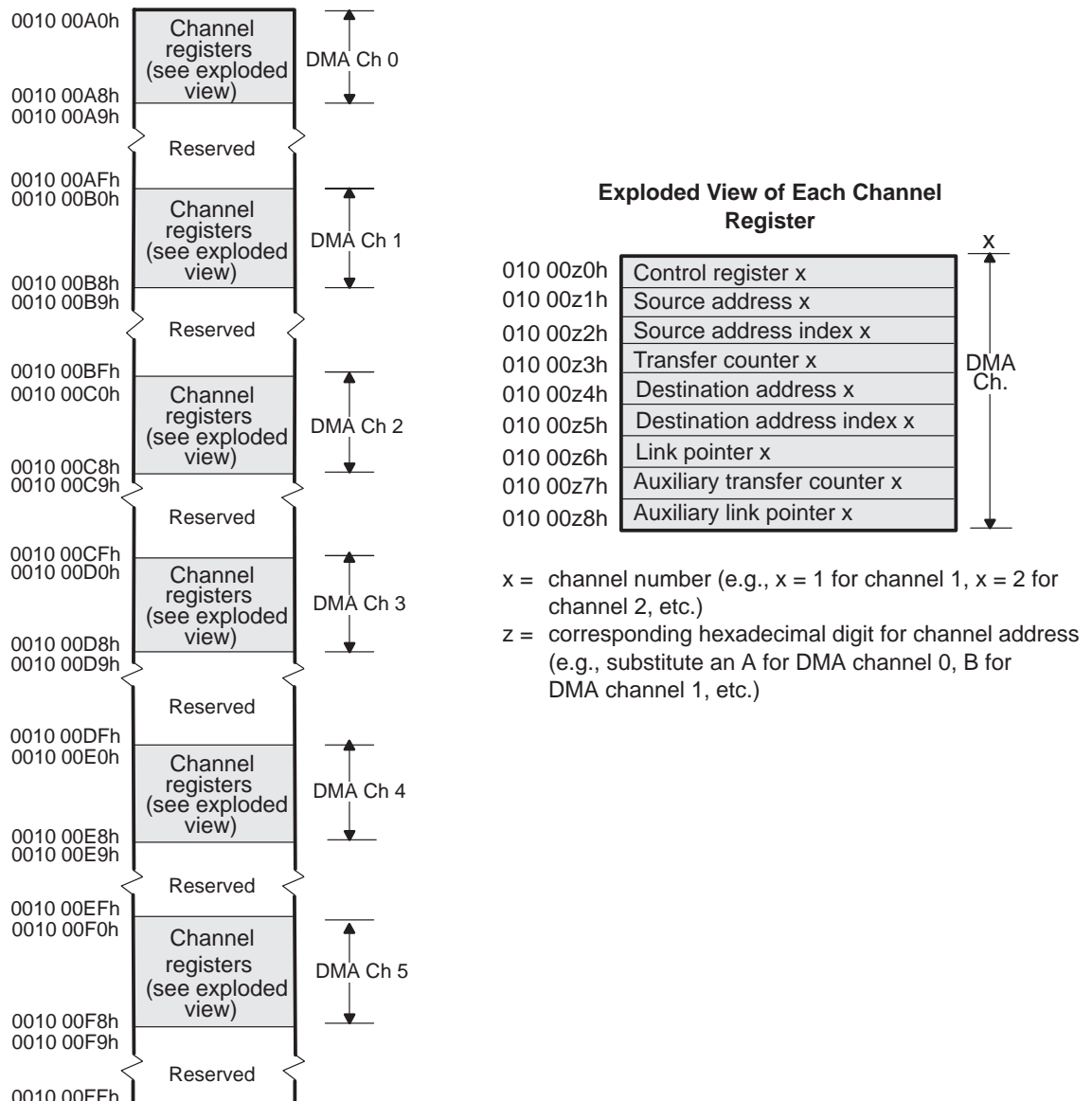

4.3 Instruction Cache

The 128×32 -bit instruction cache speeds instruction fetches and lowers system cost. The instruction cache allows the use of slow external memories while still achieving single-cycle access performance. The cache also frees the external buses from program fetches, thus, allowing the use of these buses for DMA or other system needs. The cache can operate in a completely automatic fashion without the need for external intervention. It uses a form of the LRU (least recently used) cache update algorithm.

4.3.1 Instruction Cache Architecture

The instruction cache (see Figure 4–9 on page 4-11) contains 128 32-bit words of RAM, enough to hold 128 words of program memory. It is divided into four 32-word segments. Associated with each segment is a 27-bit segment start address (SSA) register. For each word in the cache, there is a corresponding single-bit present (P) flag.

When the CPU requests an instruction word, a check is made to determine whether the word is already in the instruction cache. The partitioning of an instruction address as used by the cache control algorithm is shown in Figure 4–8. The 27 most significant bits (MSBs) of the instruction address select the segment, and the five least significant bits (LSBs) define the address of the instruction word within the pertinent segment. The 27 MSBs of the instruction address are compared with the four SSA registers. If a match is found, the relevant P flag is checked. The P flag indicates whether the word within a particular segment is already present in cache memory:

- P = 1: the word is already present in cache memory.
- P = 0: location in cache is invalid (e.g., contains garbage).

Figure 4–8. Address Partitioning for Cache Control Algorithm



If there is no match, one of the segments must be replaced by the new data. The segment replaced in this circumstance is determined by the LRU (least recently used) algorithm. The LRU stack (see the upper-right portion of Figure 4–9) is maintained for this purpose.

Figure 4–9. Instruction Cache Architecture

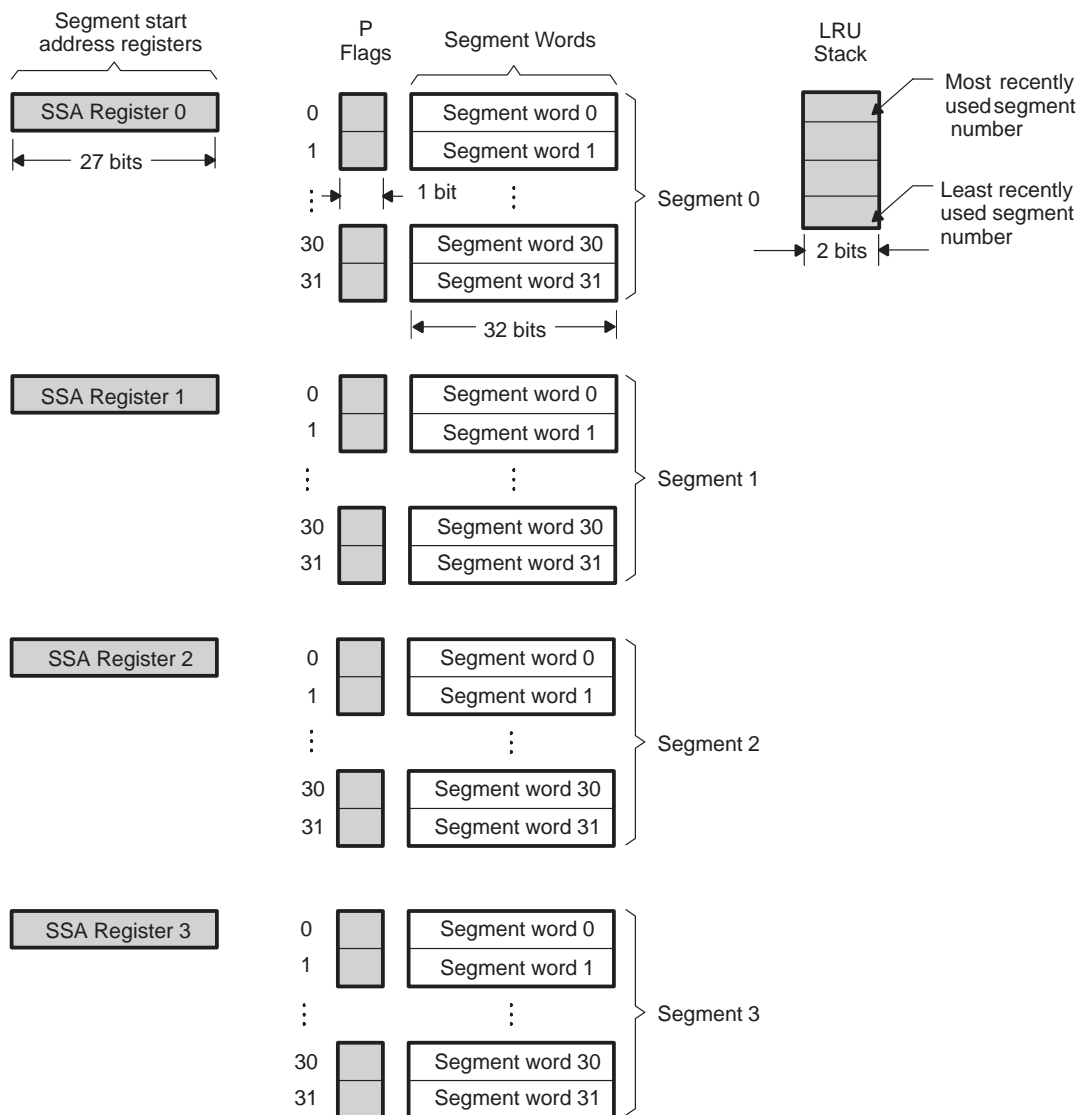

The LRU stack keeps track of which segment (0–3) qualifies as the least recently used after each access to the cache. Each time a segment is accessed, its segment number is removed from the LRU stack and pushed onto the top of the LRU stack. Therefore, the number at the top of the stack is the most recently used segment number, and the number at the bottom of the stack is the least recently used segment number.

At reset, the following occur in the instruction cache:

- Cache is disabled ($ST(CE) = 0$). After reset cache is frozen ($ST(CF) = 1$). See section 3.1.7, *Status Register (ST)*, on page 3-5, for details.
- All P flags are set to zero.
- The LRU stack is initialized with segment 0 at the top, followed by segments 1, 2, and 3 at the bottom. If any two SSA registers are equal (due to reset conditions) and a cache hit occurs, the instruction word is fetched from the most recently used segment.

When a replacement is necessary, the least recently used segment is selected for replacement. Also, the 32 P flags for the segment to be replaced are set to 0, and the segment's SSA register is replaced with the 27 MSBs of the new instruction's address.

4.3.2 Cache Control Bits

Four cache control bits are located in the CPU status register (ST): the cache clear bit (CC), the cache enable bit (CE), the cache freeze bit (CF), and the previous cache freeze bit (PCF). The status register is shown in Figure 3–3.

Cache Clear Bit (CC). Set $CC = 1$ to invalidate all entries in the cache. This bit is always cleared after it is written to; thus, it is always read as 0. At reset, 0 is written to this bit. The cache P flag = 0 when the cache is cleared.

Cache Enable Bit (CE). Set $CE = 1$ to enable the cache, allowing the cache to be used according to the LRU (least recently used) cache algorithm. Set $CE = 0$ to disable the cache; this prevents cache updates or modifications (thus, no cache fetches can be made). At reset, 0 is written to this bit. Cache clearing ($CC = 1$) is allowed when $CE = 0$.

Cache Freeze Bit (CF). Set $CF = 1$ to freeze the cache including freezing of LRU (least recently used) stack manipulation. If the cache is enabled ($CE = 1$) and the cache is frozen ($CF = 1$), fetches from the cache are allowed, but modification of the cache contents is not allowed. Cache clearing ($CC = 1$) is allowed when $CF = 1$. At reset, this bit is cleared to 0 and after reset it is set to 1. When $CF = 0$, cache clearing ($CC=1$) is allowed. CF is set to one when a trap or interrupt is taken. Also, the RETI and RETID instructions copy PCF to the CF bit.

Table 4–1 summarizes the effects of the CE and CF bits.

Table 4–1. Combined Effect of the CE and CF Bits

CE	CF	Effect
0	0	Cache not enabled
0	1	Cache not enabled
1	0	Cache enabled and not frozen
1	1	Cache enabled and frozen

Previous Cache Freeze Bit (PCF). When an interrupt or trap vector is taken, the CF value is copied to the PCF bit, and the CF bit is set to 1. This protects the cache during interrupt processing and is particularly useful when code loops are interrupted. The interrupt service routine may optionally use the cache under software control. Interrupts may also be nested, providing that the status register is saved before the interrupts are enabled. When the instructions `RETIcond` and `RETIcondD` are executed to complete interrupt processing, the contents of the PCF bit are copied to the CF bit.

4.3.3 Using the Cache

Only instructions may be fetched from the program cache. All reads and writes of data to and from memory, bypass the cache. Program fetches from internal memory do not modify the cache and do not generate cache hits or misses. The program cache is a single-access memory block. Dummy program fetches (i.e., following a branch) can generate cache misses and cache updates. Example 4–1 shows a typical way to clear and enable the cache.

Example 4–1. Enabling the Cache

```

    . . .
OR 1800h, ST
    . . .

```

To use the cache more efficiently, take two precautions:

Avoid using self-modifying code. If an instruction resides in the cache and the corresponding location in primary memory is modified, the copy in the instruction in the cache is not modified.

Align program code. Use the `.align` directive when coding assembly language to align code on 32-word address boundaries.

4.3.4 The LRU Cache Algorithm

When the 'C4x requests an instruction word from external memory, the two possible actions are a *cache hit* or a *cache miss*:

- **Cache Hit.** The cache contains the requested instruction, and the following actions occur:
 - The instruction word is read from the cache.
 - The number of the segment containing the word is removed from the LRU stack and pushed to the top of the LRU stack (if it is not already at the top), thus moving the other segment numbers toward the bottom of the stack.

- **Cache Miss.** The cache does not contain the instruction. There are two types of cache misses:
 - **Subsegment miss.** The segment address register matches the instruction address, but the relevant P flag is not set. The following actions occur:
 - The instruction word is read from memory and copied into the cache.
 - The number of the segment containing the word is removed from the LRU stack and pushed to the top of the LRU stack (if it is not already at the top), thus moving the other segment numbers toward the bottom of the stack.
 - The relevant P flag is set.
 - **Segment miss.** None of the segment addresses matches the instruction address. The following actions occur:
 - The least recently used segment is selected for replacement and the P flags for all 32 words are cleared.
 - The SSA register for the selected segment is loaded with the 27 MSBs of the address of the requested instruction word.
 - The instruction word is fetched and copied into the cache. It goes into the appropriate word of the least recently used segment. The P flag for that word is set to 1.
 - The number of the segment containing the instruction word is removed from the LRU stack and pushed to the top of the LRU stack, thus moving the other segment numbers toward the bottom of the stack.

Data Formats and Floating-Point Operation

In the 'C4x architecture, data is organized into three fundamental types: integer, unsigned-integer, and floating-point. Note that the terms, integer and signed-integer, are considered to be equivalent. The 'C4x supports short and single-precision formats for signed and unsigned integers. It also supports short, single-precision and extended-precision formats for floating-point data.

Floating-point operations make fast, trouble-free, accurate, and precise computations. Specifically, the 'C4x implementation of floating-point arithmetic facilitates floating-point operations at integer speeds while preventing problems with overflow, operand alignment, and other burdensome tasks common in integer operations.

This chapter discusses in detail the data formats and floating-point operations supported on the 'C4x.

Topic	Page
5.1 Signed-Integer Formats	5-2
5.2 Unsigned-Integer Formats	5-3
5.3 Floating-Point Formats	5-4
5.4 Floating-Point Conversion (IEEE Std. 754)	5-13
5.5 Floating-Point Multiplication	5-19
5.6 Floating-Point Addition and Subtraction	5-23
5.7 Normalization (NORM Instruction)	5-27
5.8 Rounding (RND Instruction)	5-29
5.9 Floating-Point to-Integer Conversion (FIX Instruction)	5-31
5.10 Integer-to-Floating-Point Conversion (FLOAT Instruction)	5-33
5.11 Reciprocal (RCPF Instruction)	5-34
5.12 Reciprocal Square Root (RSQRF Instruction)	5-36

5.1 Signed-Integer Formats

The 'C4x supports two signed-integer formats: a 16-bit short format and a 32-bit single-precision format. The term *integer* is used throughout this chapter to refer to a signed integer.

Note:

When extended-precision registers are used as integer operands, only bits 31–0 are used; bits 39–32 remain unchanged and unused.

5.1.1 Short Integer Format

The 16-bit twos-complement short integer format is used for immediate integer operands. For those instructions that assume integer operands, this format is sign extended to 32 bits (see Figure 5–1). The range of an integer si , represented in the short integer format, is:

$$-2^{15} \leq si \leq 2^{15} - 1$$

In Figure 5–1 and other figures in this chapter, s = sign bit.

Figure 5–1. Short-Integer Format and Sign Extension of Short Integer

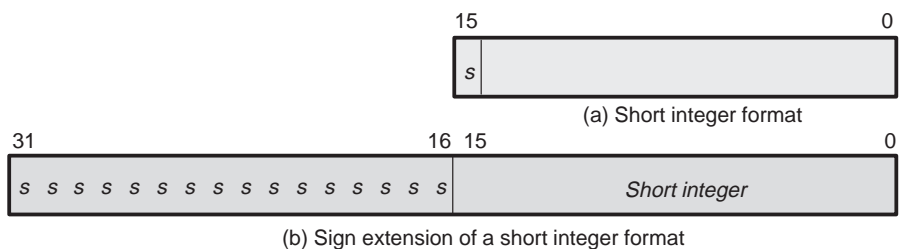

5.1.2 Single-Precision Integer Format

In the single-precision integer format, the integer is represented in twos-complement notation. The range of an integer sp , represented in the single-precision integer format, is $-2^{31} \leq sp \leq 2^{31} - 1$. Figure 5–2 shows the single-precision integer format.

Figure 5–2. Single-Precision Integer Format



5.2 Unsigned-Integer Formats

Two unsigned-integer formats are supported on the 'C4x: a 16-bit short format and a 32-bit single-precision format. In this chapter, the term *unsigned integer* is used to refer to an unsigned integer.

Note:

When extended-precision registers are used, the unsigned-integer operands use only bits 31–0; bits 39–32 remain unchanged.

5.2.1 Short Unsigned-Integer Format

Figure 5–3 shows the 16-bit short unsigned-integer format used in immediate unsigned-integer operands. For instructions that use unsigned-integer operands, the format is filled with zeros to 32 bits. The range of a short unsigned integer is $0 \leq si \leq 2^{16}$.

Figure 5–3. Short Unsigned-Integer Format and Zero Fill

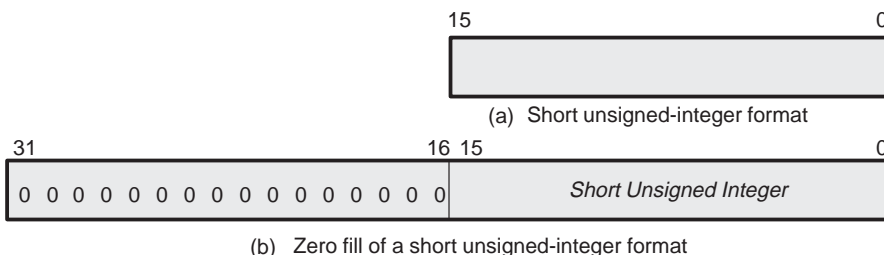

5.2.2 Single-Precision Unsigned-Integer Format

In the single-precision unsigned-integer format, the number is represented as a 32-bit value, as shown in Figure 5–4. The range of a single-precision unsigned-integer is $0 \leq sp \leq 2^{32}$.

Figure 5–4. Single-Precision Unsigned-Integer Format



5.3 Floating-Point Formats

The 'C4x supports three floating-point formats:

- A short floating-point format (for immediate floating-point operands) consisting of a 4-bit exponent, one sign bit, and an 11-bit fraction
- A single-precision format consisting of an 8-bit exponent, one sign bit, and a 23-bit fraction
- An extended-precision format consisting of an 8-bit exponent, one sign bit, and a 31-bit fraction

All 'C4x floating-point formats consist of three fields: an *exponent field (e)*, a *single-bit sign field (s)*, and a *fraction field (f)*. The sign field and fraction field may be considered as one unit and referred to as the *mantissa field (man)*. Each format is divided into these fields as shown in Figure 5–5.

Figure 5–5. General Floating-Point Format



The general equation for calculating the value in a floating point number is given by Equation 5–1. In the equation, s is the value of the sign bit, \bar{s} is the inverse of the value of the sign bit, f is the binary value of the fraction field, and e is the decimal equivalent of the exponent field.

Equation 5–1. Value in a Floating Point Number

$$x = \bar{s}s.f_2 \times 2^e$$

The mantissa represents a normalized twos-complement number. In a normalized representation, a most significant nonsign bit is implied, thus providing an additional bit of precision. The implied sign bit is used as follows:

- If $s = 0$, then the leading two bits of the mantissa are 01.
- If $s = 1$, then the leading two bits of the mantissa are 10.

If the sign bit, s , is equal to 0, the mantissa becomes $01.f_2$, where f is the binary representation of the fraction field. If s is 1, the mantissa becomes $10.f_2$, where f is the binary representation of the fraction field.

For example, if $f = 0000000001_2$ and $s = 0$, the value of the mantissa (man) would be 01.0000000001_2 . If $s = 1$ for the same value of f , the value of man would be 10.0000000001_2 .

The exponent field is a twos-complement number that determines the factor of two by which the number is multiplied. Essentially, the exponent field shifts the binary point in the mantissa. If the exponent is positive, then the binary point is shifted to the right. If the exponent is negative, then the binary point is shifted to the left.

For example, if $man = 01.0000000001_2$ and the $e = 11_{10}$, then the binary point is shifted eleven places to the right, producing the number: 010000000001_2 , which is equal to 2049 decimal.

5.3.1 Short Floating-Point Format

In the short floating-point format, floating-point numbers are represented by a twos-complement 4-bit exponent field (e) and a twos-complement 12-bit mantissa field (man) with an implied most significant nonsign bit.

Figure 5–6. Short Floating-Point Format

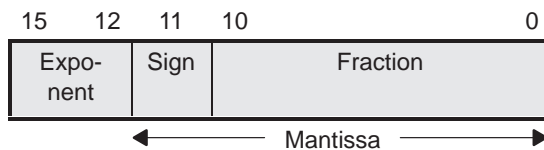

You must use the following reserved values to represent zero in the single-precision floating-point format:

$$e = -8$$

$$s = 0$$

$$f = 0$$

Operations are performed with an implied binary point between bits 11 and 10. The floating-point twos-complement number x in the short floating-point format is given by:

$$x = 01.f_2 \times 2^e \quad \text{if } s = 0$$

$$x = 10.f_2 \times 2^e \quad \text{if } s = 1$$

$$x = 0 \quad \text{if } e = -8, s = 0, f = 0$$

The following examples illustrate the range and precision of the short floating-point format:

Most Positive: $x = (2 - 2^{-11}) \times 2^7 = 2.5594 \times 10^2$

Least Positive: $x = 1 \times 2^{-7} = 7.8125 \times 10^{-3}$

Least Negative: $x = (-1 - 2^{-11}) \times 2^{-7} = -7.8163 \times 10^{-3}$

Most Negative: $x = -2 \times 2^7 = -2.5600 \times 10^2$

5.3.2 Single-Precision Floating-Point Format

In the single-precision format, the floating-point number is represented by an 8-bit exponent field (*e*) and a twos-complement 24-bit mantissa field (*man*) with an implied most significant nonsign bit.

Operations are performed with an implied binary point between bits 23 and 22. When the implied most significant nonsign bit is made explicit, it is located to the immediate left of the binary point. The floating-point number *x* is given by

$$\begin{aligned}
 x &= 01.f \times 2^e && \text{if } s = 0 \\
 x &= 10.f \times 2^e && \text{if } s = 1 \\
 x &= 0 && \text{if } e = -128, s = 0, f = 0
 \end{aligned}$$

Figure 5–7. Single-Precision Floating-Point Format



You must use the following reserved values to represent zero in the single-precision floating-point format:

$$\begin{aligned}
 e &= -128 \\
 s &= 0 \\
 f &= 0
 \end{aligned}$$

The following examples illustrate the range and precision of the single-precision floating-point format.

$$\begin{aligned}
 \text{Most Positive:} & \quad x = (2 - 2^{-23}) \times 2^{127} = 3.4028234 \times 10^{38} \\
 \text{Least Positive:} & \quad x = 1 \times 2^{-127} = 5.8774717 \times 10^{-39} \\
 \text{Least Negative:} & \quad x = (-1 - 2^{-23}) \times 2^{-127} = -5.8774724 \times 10^{-39} \\
 \text{Most Negative:} & \quad x = -2 \times 2^{127} = -3.4028236 \times 10^{38}
 \end{aligned}$$

5.3.4 Determining the Decimal Equivalent of a Floating-Point Number

There are two basic steps in determining the value stored in floating point format:

- 1) Determine the values of the exponent and mantissa.
- 2) Shift the binary point in the mantissa according to the value of the exponent field and then convert the number to decimal.

5.3.4.1 Step 1: Determine the Values of the Exponent and Mantissa

The exponent field is a twos-complement number whose range depends on the type of floating-point number you are converting. Record the decimal equivalent of this value as e .

For example, if you are converting a single-precision floating-point number and the binary value of the exponent field is 00000100, then the decimal value of the exponent would be 4 since a 1 in the third bit from the right corresponds to 4.

If, on the other hand, the binary value of the exponent field is 11111100₂, then the decimal value of the exponent would be -4. Since the first bit on the left is 1, you know that the number is negative. You calculate the value of the number by taking the one's complement of 11111100₂, which is 00000011₂ and then by adding 1 to that result.

Note:

If the value of the exponent matches the value reserved for zero, then the floating point number is equal to zero. The reserved value for each floating point type is given with the type descriptions in Section 5.3.

The mantissa is a binary number with an implied binary point between the sign bit and the fraction field. Form the mantissa in one of two ways:

- If $s = 0$, form the mantissa by writing 01. and appending the bits in the fraction field after the binary point.

For example, if $f = 10100000000_2$, then $man = 01.10100000000_2$:

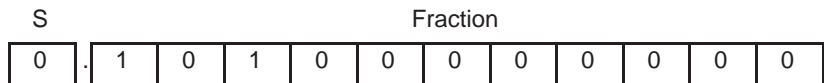

Rewrite the mantissa as:

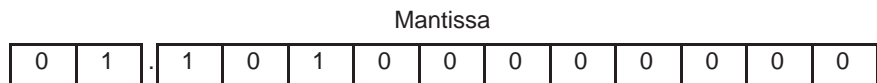

5.3.5 Conversion Between Floating-Point Formats

Floating-point operations assume several different formats for inputs and outputs. These formats often require conversion from one floating-point format to another (for example, from short floating-point format to extended-precision floating-point format). Format conversions occur automatically in hardware, with no overhead, as a part of floating-point operations. Examples of the four conversions are shown in Figure 5–9 through Figure 5–12 (s = sign bit of the exponent). When a floating-point format zero is converted to a different format, it is always converted to a valid representation of zero in that format.

Figure 5–9. Short Floating-Point Format Conversion to Single-Precision Floating-Point Format

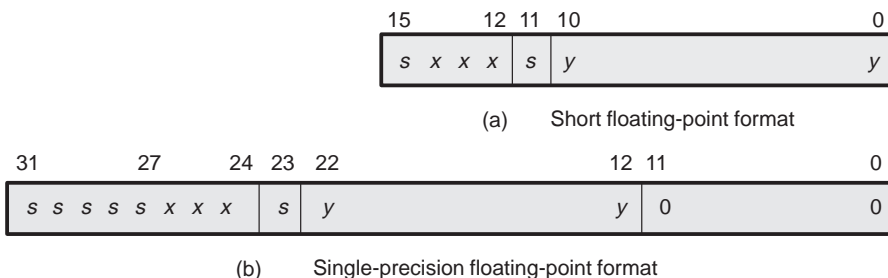

In converting from short format to single-precision format, the exponent field is sign extended and the rightmost 12 bits of the fraction field are filled with zeros.

Figure 5–10. Short Floating-Point Format Conversion to Extended-Precision Floating-Point Format

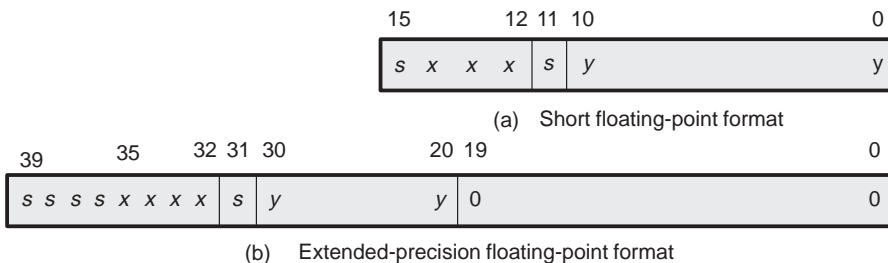

In converting from short format to extended-precision format, the exponent field is sign extended and the rightmost 20 bits of the fraction field are filled with zeros.

Figure 5–11. Single-Precision Floating-Point Format Conversion to Extended-Precision Floating-Point Format

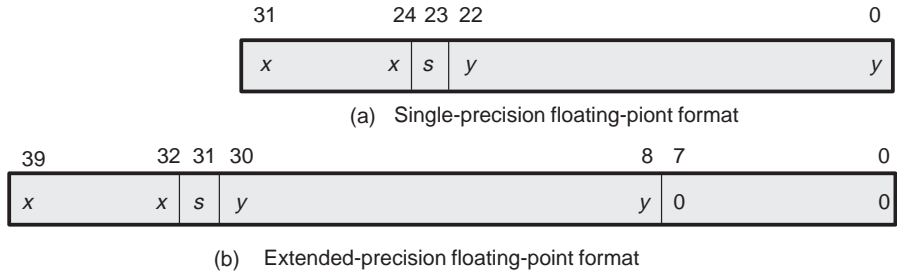

In converting from single-precision format to extended-precision format, the rightmost eight bits of the fraction field are filled with zeros.

Figure 5–12. Extended-Precision Floating-Point Format Conversion to Single-Precision Floating-Point Format

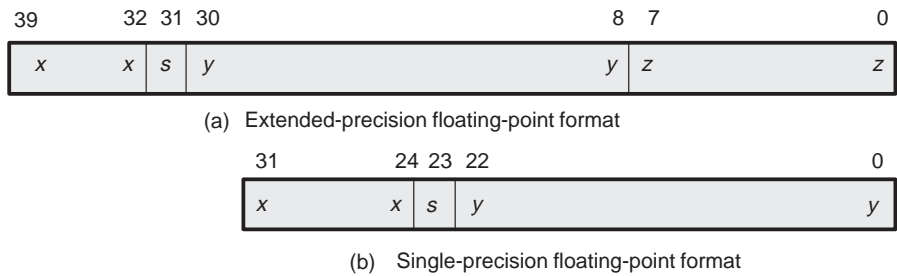

In converting from extended-precision format to single-precision format, the eight rightmost bits of the fraction field are truncated.

5.4 Floating-Point Conversion (IEEE Std. 754)

The 'C4x floating-point format is not compatible with the IEEE standard 754 format. However, the 'C4x has instructions to directly convert to and from IEEE format (TOIEEE and FRIEEE, respectively). The conversion process is explained in subsections 5.4.1 and 5.4.2. Figure 5–13 shows the IEEE floating-point format, and Figure 5–14 shows the floating-point 'C4x format.

Figure 5–13. IEEE Single-Precision Std. 754 Floating-Point Format



The following five cases define the value v of a number expressed in the IEEE format:

- 1) If $e = 255$ and $f \neq 0$, then $v = \text{NaN}$
- 2) If $e = 255$ and $f = 0$, then $v = (-1)^s \text{infinite}$
- 3) If $0 < e < 255$, then $v = (-1)^s \times 2^{e-127}(1.f)$
- 4) If $e = 0$ and $f \neq 0$, then $v = (-1)^s \times 2^{-126}(0.f)$
- 5) If $e = 0$ and $f = 0$, then $v = (-1)^s \times 0$ (zero).

where s = sign bit; e = the exponent field; f = the fraction field; NaN = Not a number

For the above five representations, e is treated as an unsigned integer. Case 1 generates NaN (not an number) and is primarily used for software signaling. Case 4 represents a denormalized number. Case 5 represents positive and negative zero.

Figure 5–14. 'C4x Single-Precision Twos-Complement Floating-Point Format‡



‡ Same format as for the 'C3x

In comparison, Figure 5–14 shows the the 'C4x twos-complement floating-point format. In this format, two cases can be used to define value v of a number:

- 1) If $e = -128$ and $f \neq 0$, then $v = 0$
- 2) If $e \neq -128$ then $v = \overline{s}s.f_2 \times 2^e$

where s = sign bit; e = the exponent field; f = the fraction field.

For this representation, e is treated as a twos-complement integer. The fraction and sign bit form a normalized twos-complement mantissa.

Note: Differentiating Symbols for IEEE and 'C4x Formats

To differentiate between the symbols that define these two formats, all IEEE fields are subscripted with an IEEE (e.g., e_{IEEE} , s_{IEEE} , etc.). Similarly, all twos-complement fields are subscripted with two (i.e., e_{two} , s_{two} , f_{two}).

5.4.1 Converting IEEE Format to Twos-Complement 'C4x Floating-Point Format

The most common conversion is the IEEE-to-twos-complement format. This conversion is done according to rules in the following table:

Table 5–1. Converting IEEE Format to Twos-Complement Floating-Point Format

Case	If These Values Are Present			Then These Values Equal			
	e_{IEEE}	s_{IEEE}	f_{IEEE}	e_{two}	s_{two}	f_{two}	s_{IEEE}
1	255	1		7Fh	1	00 0000h	
2	255	0		7Fh	0	7F FFFFh	
3	$0 < e_{IEEE} < 255$	0		$e_{IEEE}-7Fh$		f_{IEEE}	0
4	$0 < e_{IEEE} < 255$	1	$\neq 0$	$e_{IEEE}-7Fh$		$\bar{f}_{IEEE}+1^\dagger$	1
5	$0 < e_{IEEE} < 255$	1	0	$e_{IEEE}-80h$		0	1
6	0			80h	0	00 0000h	

$^\dagger \bar{f}_{IEEE}$ = ones complement of f_{IEEE} .

Case 1 maps the IEEE positive NaNs and positive infinity to the single-precision twos-complement most positive number. Overflow is also signaled to allow you to check for these special cases.

Case 2 maps the IEEE negative NaNs and negative infinity to the single-precision twos-complement most negative number. Overflow is also signaled to allow you to check for these special cases.

Case 3 maps the IEEE positive normalized numbers to the identical value in the twos-complement positive number.

Case 4 maps the IEEE negative normalized numbers with a nonzero fraction to the identical value in the twos-complement negative number.

Case 5 maps the IEEE negative normalized numbers with a zero fraction to the identical value in the twos-complement negative number.

Case 6 maps the IEEE positive and negative denormalized numbers and positive and negative zeros to a twos-complement zero.

The 'C4x assumes that an IEEE number is stored as an integer in memory or in a register. When the 'C4x converts an IEEE number, it places the number in an extended-precision register by using the exponent and fraction fields of the register. The eight LSBs of the extended-precision register are set to zero. Any arithmetic operations that are performed on the fraction field of the IEEE number should be performed only on the IEEE fraction field. In the case of a block memory transfer, a no-penalty data format conversion can be executed by using parallel instructions with STF. Example 5–4 illustrates how this can be accomplished.

Example 5–4. IEEE to 'C4x Conversion Within Block Memory Transfer

```

*   TITLE IEEE TO 'C4x CONVERSION WITHIN BLOCK MEMORY
*   TRANSFER
*
*   PROGRAM ASSUMES THAT INPUT FIFO OF COMMUNICATION PORT 0
*   IS FULL OF IEEE FORMAT DATA. EIGHT DATA WORDS ARE
*   TRANSFERRED FROM COMMUNICATION PORT 0 TO INTERNAL RAM
*   BLOCK 0 AND THE DATA FORMAT IS CONVERTED FROM IEEE FORMAT
*   TO 'C4x FLOATING-POINT FORMAT.
*
*
*   .
*   .
*   .
*   LDI   @CP0_IN,AR0 ;Load comm port0 input FIFO address
*   LDI   @RAM0,AR1  ;Load internal RAM block 0 address
*   FRIEEE *AR0,R0   ;Convert first data
*   RPTS  6
*   FRIEEE *AR0,R0   ;Convert next data
*   ||   STF    R0,*AR1++(1) ;Store previous data
*   STF    R0,*AR1++(1) ;Store last data
*   .
*   .
*   .

```

5.4.2 Converting Twos-Complement 'C4x Floating-Point Format to IEEE Format

This conversion is performed according to the following table:

Table 5–2. Converting Twos-Complement Floating-Point Format to IEEE Format

Case	If These Values Are Present			Then These Values Equal		
	e_{two}	s_{two}	f_{two}	e_{IEEE}	s_{IEEE}	f_{IEEE}
1	-128			00h	0	00 0000h
2	-127			00h	0	00 0000h
3	$-126 \leq e_{two} \leq 127$	0		$e_{two} + 7Fh$	0	f_{two}
4	$-126 \leq e_{two} \leq 127$	1	$\neq 0$	$e_{two} + 7Fh$	0	$\bar{f}_{two} + 1^\dagger$
5	$-126 \leq e_{two} \leq 127$	1	0	$e_{two} + 80h$	1	00 0000h
6	127	1	0	FFh	1	00 0000h

† \bar{f}_{two} = ones complement of f_{two} .

Case 1 maps a twos-complement zero to a positive IEEE zero.

Case 2 maps the twos-complement numbers that are too small to be represented as normalized IEEE numbers to a positive IEEE zero.

Case 3 maps the positive twos-complement numbers that are not covered by case 2 into the identically valued IEEE number.

Case 4 maps the negative twos-complement numbers with a nonzero fraction that are not covered in case 2 into the identically valued IEEE number.

Case 5 maps all the negative twos-complement numbers with a zero fraction, except for the most negative twos-complement number and those that are not covered in case 2, into the identically valued IEEE number.

Case 6 maps the most negative twos-complement number to the IEEE negative infinity.

The 'C4x assumes that the twos-complement numbers are in memory or are in an extended-precision register in the exponent and fraction field of the register (shown in Figure 5–14 on page 5-13). If the value is in an extended-precision register, then only the 24 MSBs of the fraction field are manipulated as the fraction field and for detection of the special cases. The result of the conversion goes into the 32 MSBs of an extended-precision register. In the case of a block memory transfer, a no-penalty data format conversion can be executed by using parallel instructions with STF. Example 5–5 illustrates how this can be accomplished.

Example 5–5. 'C4x to IEEE Conversion Within Block Memory Transfer

```

*  TITLE  'C4x TO IEEE CONVERSION WITHIN BLOCK MEMORY
*  TRANSFER
*
*  PROGRAM ASSUMES THAT OUTPUT FIFO OF COMMUNICATION PORT 0
*  IS EMPTY. EIGHT DATA WORDS ARE TRANSFERRED FROM
*  INTERNAL RAM BLOCK 0 TO COMMUNICATION PORT 0 AND THE
*  DATA FORMAT IS CONVERTED FROM 'C4x FLOATING-POINT FORMAT
*  TO IEEE FORMAT.
*
      .
      .
      .
      LDI   @CP0_OUT,AR0 ;Load comm port0 output FIFO
                        ; address
      LDI   @RAM0,AR1   ;Load internal RAM block 0
                        ; address
      TOIEEE *AR1++(1),R0 ;Convert first data
      RPTS  6
      TOIEEE *AR1++(1),R0 ;Convert next data
||  STF   R0,*AR0      ;Store previous data
      STF   R0,*AR0      ;Store last data
      .
      .
      .

```

5.5 Floating-Point Multiplication

A floating-point number α can be written in floating-point format as in the following formula, where $\alpha(man)$ is the mantissa and $\alpha(exp)$ is the exponent:

$$\alpha = \alpha(man) \times 2^{\alpha(exp)}$$

The product of α and b is c , defined as:

$$c = \alpha \times b = \alpha(man) \times b(man) \times 2^{(\alpha(exp)+b(exp))}$$

Thus:

$$c(man) = \alpha(man) \times b(man)$$

$$c(exp) = \alpha(exp) + b(exp)$$

During floating-point multiplication, the source operands are always in the extended-precision floating-point format. If the source operands are in short or single-precision format, they are converted to extended-precision format. These conversions occur automatically in hardware with no overhead. All results of floating-point multiplications are returned in the extended-precision format.

A multiplication occurs in a single cycle.

Figure 5–15 is a flowchart showing the steps involved in a floating-point multiplication. Each step is labelled with a number in parentheses.

- In step 1, the 32-bit source mantissas, $\alpha(man)$ and $b(man)$, are multiplied, producing a 64-bit result, $c(man)$. (Note that input and output data are always represented as normalized numbers.)
- In step 2, the exponents, $\alpha(exp)$ and $b(exp)$, are added, yielding $c(exp)$.
- Step 3 checks whether or not $c(man)$ is equal to zero. If $c(man)$ is zero, step 7 sets $c(exp)$ to -128 , thus yielding the representation for zero.
- Steps 4 and 5 normalize the result.
- If a right shift of one is necessary, then in step 8, $c(man)$ is right-shifted one bit, and 1 is added to $c(exp)$.
- If a right shift of two is necessary, then in step 9, $c(man)$ is right-shifted two bits, and 2 is added to $c(exp)$. step 6 occurs when the result is normalized.
- In step 10, $c(man)$ is set in the extended-precision floating-point format.
- Steps 11 through 16 check for special cases of $c(exp)$.
- In step 14, if $c(exp)$ has overflowed (detected in step 11) in the positive direction, then $c(exp)$ is set to the most positive extended-precision format value. If $c(exp)$ has overflowed in the negative direction, then $c(exp)$ is set to the most negative extended-precision format value.

- If $c(exp)$ has underflowed (detected in step 12), then c is set to zero in step 15; i.e., $c(man) = 0$ and $c(exp) = -128$.

Figure 5–15. Flowchart for Floating-Point Multiplication

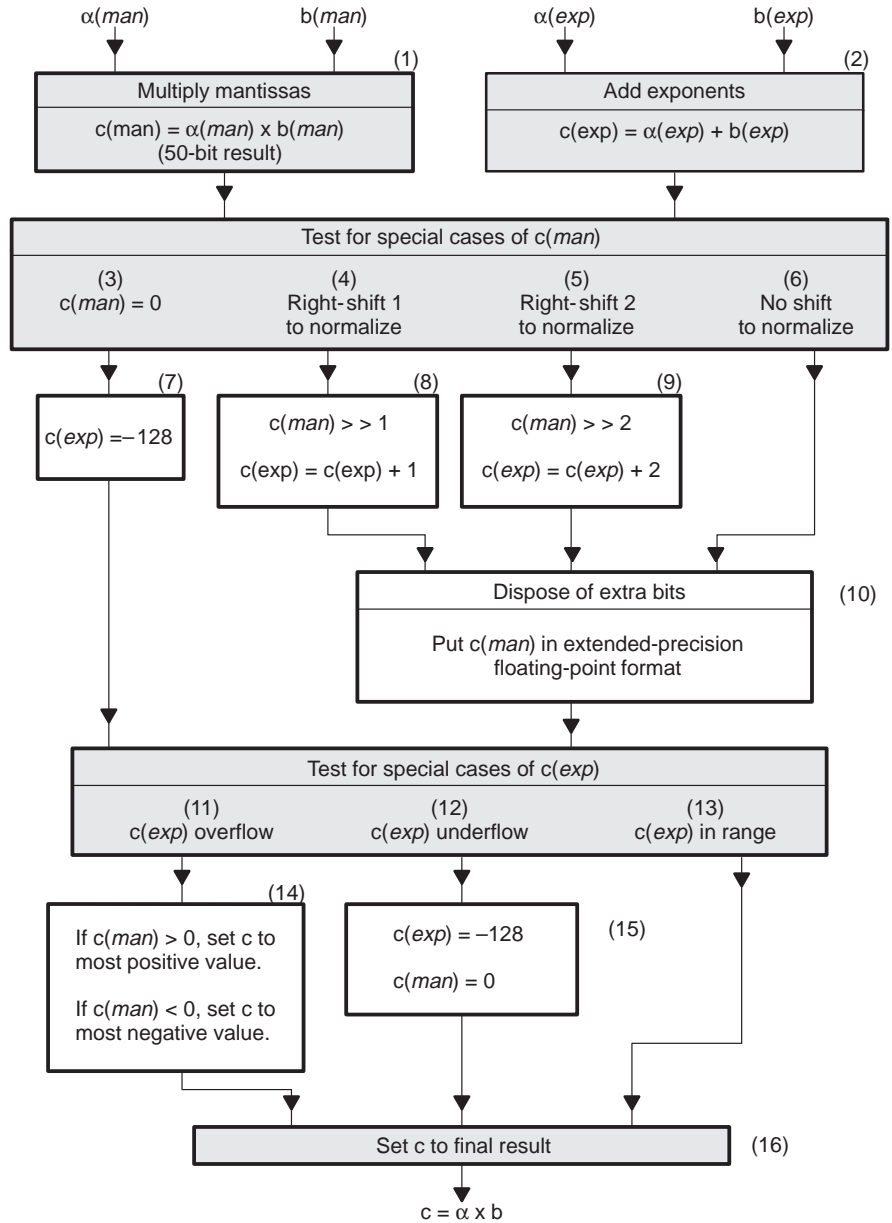

Example 5–8. Floating-Point Multiply (Both Mantissas = 1.0)

Let

$$\alpha = 1.0 \times 2^{\alpha(\text{exp})} = 01.000000000000000000000000 \times 2^{\alpha(\text{exp})}$$

$$b = 1.0 \times 2^{b(\text{exp})} = 01.000000000000000000000000 \times 2^{b(\text{exp})}$$

where a and b are both represented in binary form according to the single-precision floating-point format. Then

$$\begin{array}{r} 01.000000000000000000000000 \times 2^{\alpha(\text{exp})} \\ \times 01.000000000000000000000000 \times 2^{b(\text{exp})} \\ \hline 0001.000000000000000000000000 \times 2^{(\alpha(\text{exp}) + b(\text{exp}))} \end{array}$$

This number is in the proper normalized format. Therefore, no shift of the mantissa or modification of the exponent is necessary.

The previous three examples show cases in which the product of two normalized numbers can be normalized with a shift of zero, one, or two. The floating-point format of the 'C4x makes this possible.

Example 5–9. Floating-Point Multiply Between Positive and Negative Numbers

Let

$$\alpha = 1.0 \times 2^{\alpha(\text{exp})} = 01.000000000000000000000000 \times 2^{\alpha(\text{exp})}$$

$$b = -2.0 \times 2^{b(\text{exp})} = 10.000000000000000000000000 \times 2^{b(\text{exp})}$$

Then

$$\begin{array}{r} 01.000000000000000000000000 \times 2^{\alpha(\text{exp})} \\ \times 10.000000000000000000000000 \times 2^{b(\text{exp})} \\ \hline 1110.000000000000000000000000 \times 2^{(\alpha(\text{exp}) + b(\text{exp}))} \end{array}$$

The result is $c = -2.0 \times 2^{(\alpha(\text{exp}) + b(\text{exp}))}$

Floating-Point Multiply by Zero

All multiplications by a floating-point zero yield a result of zero ($f = 0$, $s = 0$, and $\text{exp} = -128$).

5.6 Floating-Point Addition and Subtraction

In floating-point addition and subtraction, two floating-point numbers α and b can be defined as

$$\alpha = \alpha(\text{man}) \times 2^{\alpha(\text{exp})}$$

$$b = b(\text{man}) \times 2^{b(\text{exp})}$$

The sum (or difference) of α and b can be defined as

$$\begin{aligned} c &= \alpha \pm b \\ &= (\alpha(\text{man}) \pm (b(\text{man}) \times 2^{-(\alpha(\text{exp})-b(\text{exp}))})) \times 2^{\alpha(\text{exp})}, \\ &\quad \text{if } \alpha(\text{exp}) \geq b(\text{exp}) \\ &= ((\alpha(\text{man}) \times 2^{-(b(\text{exp})-\alpha(\text{exp}))}) \pm b(\text{man})) \times 2^{b(\text{exp})}, \\ &\quad \text{if } \alpha(\text{exp}) < b(\text{exp}) \end{aligned}$$

Figure 5–16 is the flowchart for floating-point addition. Because this flowchart assumes signed data, it is also appropriate for floating-point subtraction. In this figure, it is assumed that $\alpha(\text{exp}) \leq b(\text{exp})$. Steps are shown as numbers in parentheses in the figure.

- In step 1, the source exponents are compared, and $c(\text{exp})$ is set equal to the largest of the two source exponents.
- In step 2, d is set to the difference of the two exponents.
- In step 3, the mantissa with the smallest exponent, in this case $\alpha(\text{man})$, is right-shifted d bits in order to align the mantissas.
- In step 4, after the mantissas have been aligned, they are added.
- In steps 5 through 7 check for a special case of $c(\text{man})$. If $c(\text{man})$ is zero (step 5), then $c(\text{exp})$ is set to its most negative value (step 8) to yield the correct representation of zero. If $c(\text{man})$ has overflowed c (step 6), then in step 9, $c(\text{man})$ is right-shifted one bit, and 1 is added to $c(\text{exp})$. In step 10, the result is normalized.
- In steps 11 and 12, special cases of $c(\text{exp})$ are tested. If $c(\text{exp})$ has overflowed, then c is set to the most positive extended-precision value if it is positive; if it is negative, it is set to the most negative extended-precision value.

Figure 5–16. Flowchart for Floating-Point Addition

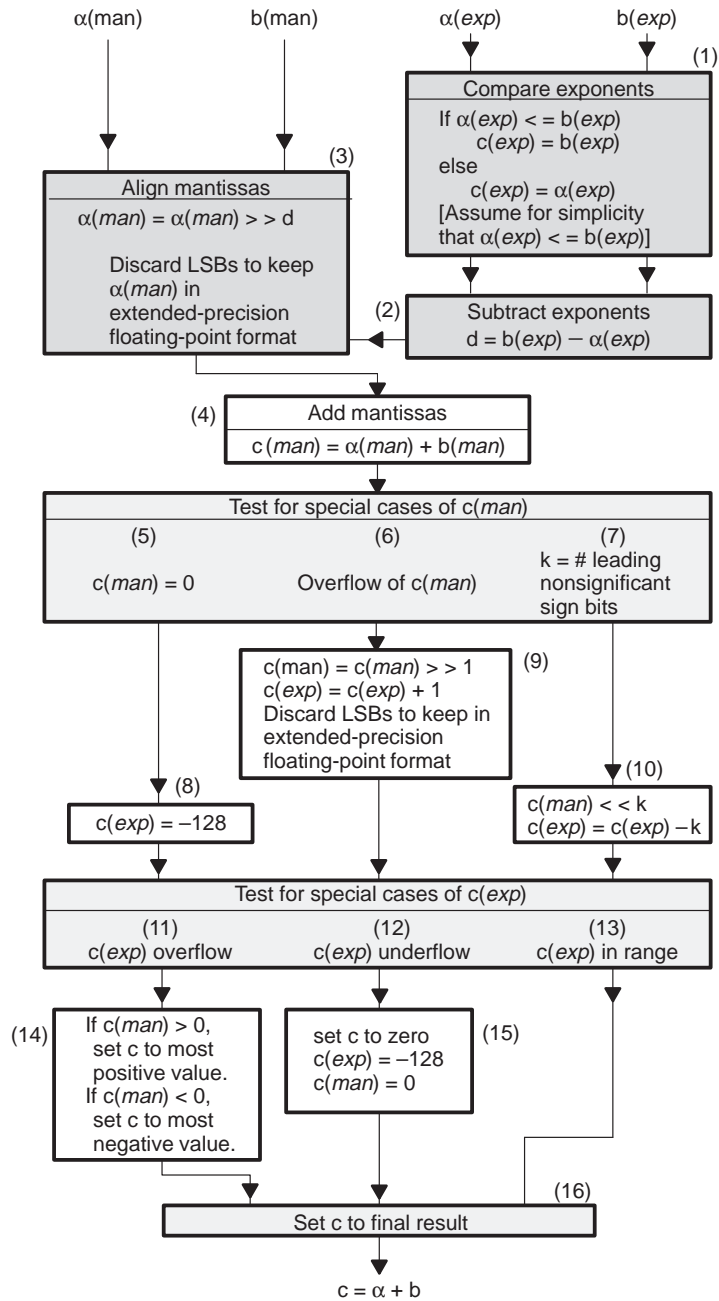

The following examples describe the floating-point addition and subtraction operations. It is assumed that the data is in the extended-precision floating-point format.

Example 5–10. Floating-Point Addition

Let

$$\alpha = 1.5 = 01.10000000000000000000000000000000 \times 2^0$$

$$b = 0.5 = 01.00000000000000000000000000000000 \times 2^{-1}$$

It is necessary to shift b to the right by one so that α and b have the same exponent. This yields

$$b = 0.5 = 00.10000000000000000000000000000000 \times 2^0$$

Then

$$\begin{array}{r} 01.10000000000000000000000000000000 \times 2^0 \\ + 00.10000000000000000000000000000000 \times 2^0 \\ \hline 010.00000000000000000000000000000000 \times 2^0 \end{array}$$

As in the case of multiplication, it is necessary to shift the binary point one place to the left and to add 1 to the exponent. This yields

$$\begin{array}{r} 01.10000000000000000000000000000000 \times 2^0 \\ + 00.10000000000000000000000000000000 \times 2^0 \\ \hline 01.00000000000000000000000000000000 \times 2^1 \end{array}$$

Example 5–11. Floating-Point Subtraction

Let

$$\alpha = 01.00000000000000000000000000000001 \times 2^0$$

$$b = 01.00000000000000000000000000000000 \times 2^0$$

The operation to be performed is $\alpha - b$. The mantissas are already aligned because the two numbers have the same exponent. The result is a large cancellation of the upper bits, as shown below.

$$\begin{array}{r} 01.00000000000000000000000000000001 \times 2^0 \\ - 01.00000000000000000000000000000000 \times 2^0 \\ \hline 00.00000000000000000000000000000001 \times 2^0 \end{array}$$

5.7 Normalization (NORM Instruction)

The NORM instruction normalizes an extended-precision floating-point number that is assumed to be unnormalized. Since the number is assumed to be unnormalized, no implied most significant nonsign bit is assumed. The NORM instruction executes three steps:

- 1) Locates the most significant nonsign bit of the floating-point number
- 2) Left shifts to normalize the number
- 3) Adjusts the exponent

Given the extended-precision floating-point value α to be normalized, the normalization is performed as shown in Figure 5–17.

Figure 5–17. Flowchart for NORM Instruction Operation

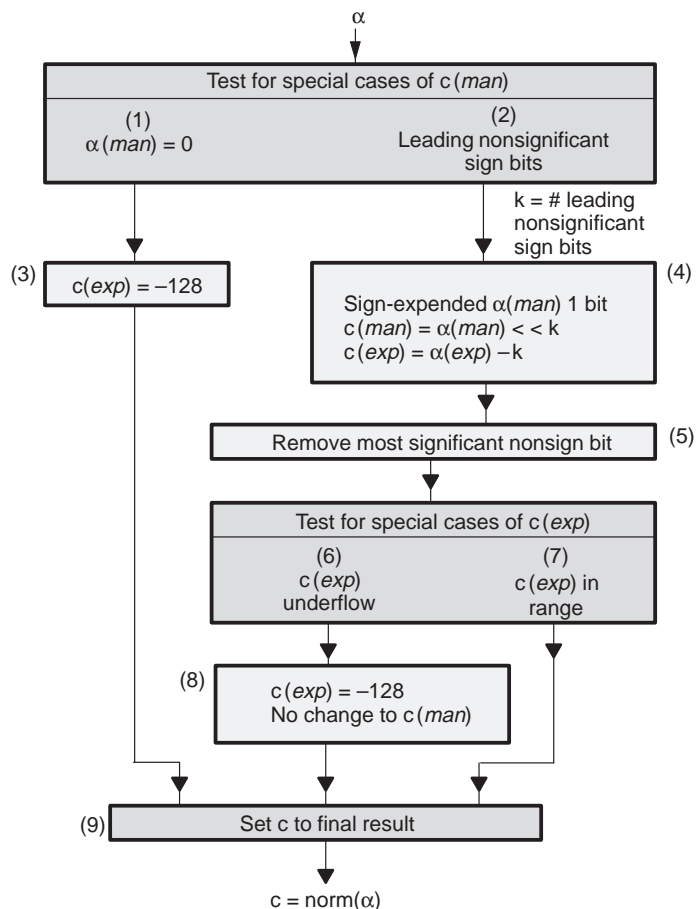

Example 5–14. NORM Instruction

Assume that an extended-precision register contains the value:

man = 000000000000000000100000000001, *exp* = 0

When the normalization is performed on a number assumed to be unnormalized, the binary point is assumed to be:

man = 0.000000000000000000100000000001, *exp* = 0

This number is then sign extended one bit so that the mantissa contains 33 bits:

man = 00.000000000000000000100000000001, *exp* = 0

Here is the intermediate result after the most significant nonsign bit is located and the shift is performed:

man = 01.000000000001000000000000000000, *exp* = -19

The final 32-bit value output after removing the redundant bit is:

man = 000000000001000000000000000000, *exp* = -19

The NORM instruction is useful for counting the number of leading zeros or leading ones in a 32-bit field. If the exponent is initially zero, the absolute value of the final value of the exponent is the number of leading ones or zeros. This instruction is also useful for manipulating unnormalized floating-point numbers.

5.8 Rounding (RND Instruction)

The RND instruction rounds a number from the extended-precision floating-point format to the single-precision floating-point format in a single cycle. Rounding (rnd) is similar to floating-point addition. Given the number α to be rounded, the following operation is performed first.

$$c = \alpha(man) \times 2^{\alpha(exp)} + (1 \times 2^{\alpha(exp)-24})$$

Next, a conversion from extended-precision floating-point to single-precision floating-point format is performed. Given the extended-precision floating-point value, rounding is performed as shown in Figure 5–18.

Note:

RND *src, dst* — where (*src*) = 0 — does not set the zero condition flag (bit 2 in the status register). Instead, it sets the underflow condition flag (bit 4 in the status register). When required, check for the underflow condition instead of the zero condition.

Figure 5–18. Flowchart for Floating-Point Rounding by the RND Instruction

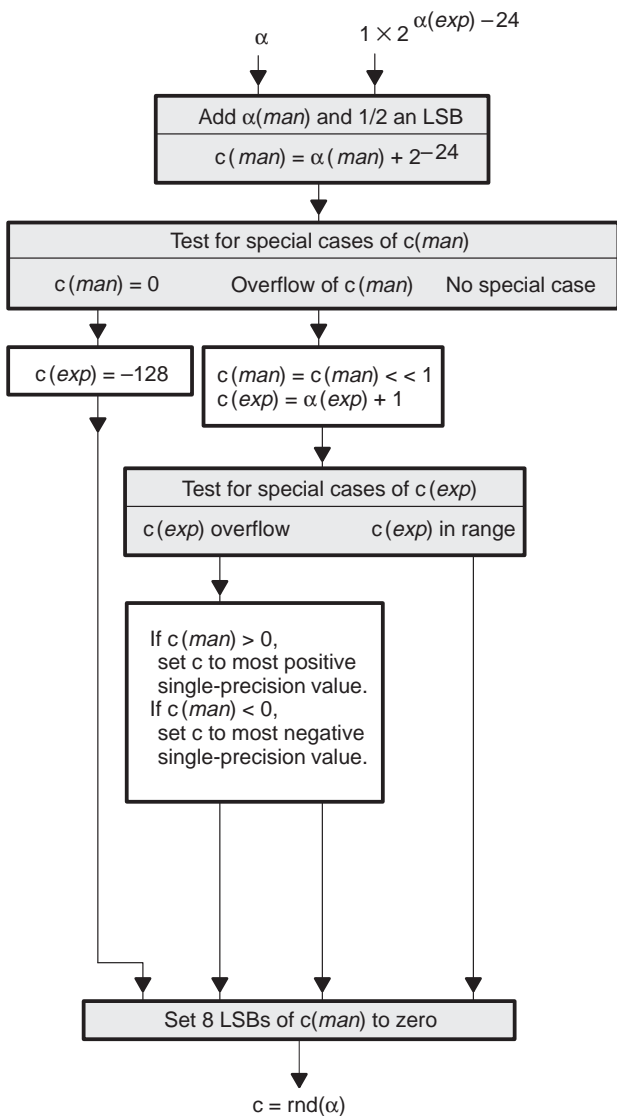

5.9 Floating-Point-to-Integer Conversion (FIX Instruction)

Using the FIX instruction, you can convert an extended-precision floating-point number to a single-precision integer in a single cycle. The floating-point to integer conversion of the value x is referred to here as $\text{fix}(x)$. The conversion does not overflow if α , the number to be converted, is in the range $-2^{31} \leq \alpha \leq 2^{31} - 1$

First, you must be certain that:

$$\alpha(\text{exp}) \leq 30$$

If these bounds are not met, an overflow occurs. If an overflow occurs in the positive direction, the output is the most positive integer. If an overflow occurs in the negative direction, the output is the most negative integer. If $\alpha(\text{exp})$ is within the valid range, then $\alpha(\text{man})$, with implied bit included, is sign-extended and right-shifted (rs) by the amount:

$$\text{rs} = 31 - \alpha(\text{exp})$$

This right shift (rs) shifts out those bits corresponding to the fractional part of the mantissa. For example:

If $0 \leq x < 1$, then $\text{fix}(x) = 0$.

If $-1 \leq x < 0$, then $\text{fix}(x) = -1$.

The flowchart for the floating-point-to-integer conversion is shown in Figure 5–19.

Figure 5–19. Flowchart for Floating-Point-to-Integer Conversion by FIX Instruction

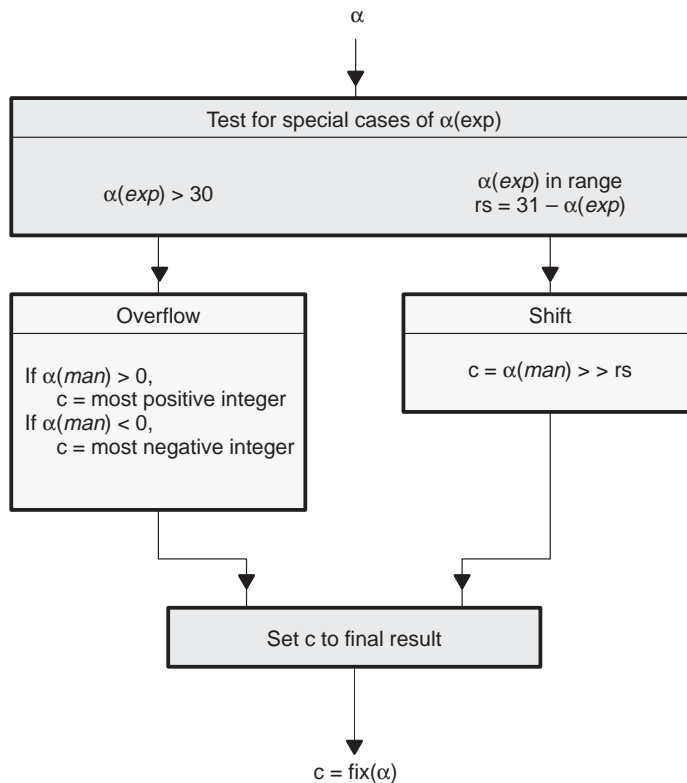

5.10 Integer-to-Floating-Point Conversion (FLOAT Instruction)

Integer-to-floating-point conversion performed by the FLOAT instruction allows a single-precision integer to be converted to an extended-precision floating-point number in a single cycle. The flowchart for this conversion is shown in Figure 5–20.

Figure 5–20. Flowchart for Integer-to-Floating-Point Conversion by FLOAT Instructions

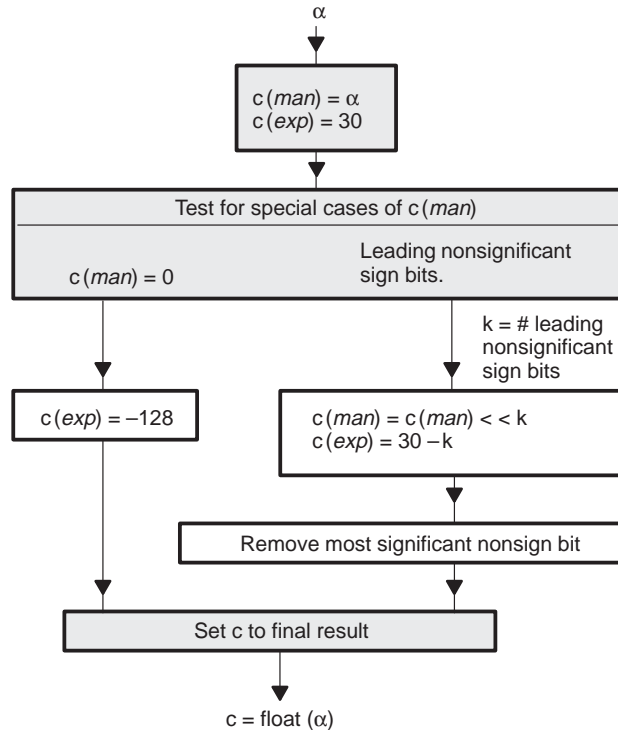

5.11 Reciprocal (RCPF Instruction)

The RCPF instruction generates a satisfactory estimate of the reciprocal of a floating-point number in a single cycle. The estimate has the correct exponent, and the mantissa is accurate to the eighth binary position (mantissa error is thus $< 2^{-8}$) giving a 16-bit representation of the result (8-bit exponent plus 8-bit mantissa). Also, this estimate can be used as a seed for an algorithm to compute the reciprocal to even greater accuracy. (The Newton-Raphson algorithm, described in this section, is one such case.)

Figure 5–21 below depicts the algorithm used by instruction RCPF.

- ❑ The input is assumed to be $v = vman \times 2^{vexp}$.
- ❑ The output is assumed to be $x = xman \times 2^{xexp}$.
- ❑ $vexp$ is negated.
- ❑ If $vexp = -128$, the result is saturated to the most positive number, and the overflow flag is set. The N condition flag is set to the same sign as $vsign$.

Figure 5–21. RCPF Instruction Algorithm

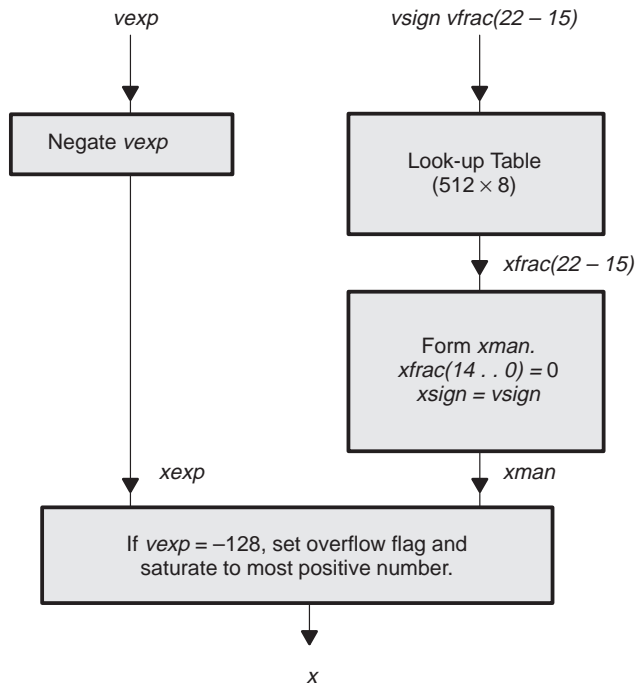

The look-up table is read by forming a nine-bit address consisting of *vsign* and bits 22–15 of *vfrac*. The eight-bit output of the look-up table forms bits 22–15 of *xfrac*. Bits 14–0 of *xfrac* are cleared to zero. *xsign* is set to *vsign*.

The look-up table values are generated from simulation results.

5.11.1 Reciprocal Algorithm

The RCPF instruction provides the reciprocal of a number. The estimate has the correct exponent and a mantissa accurate to the eighth binary place (i.e., the error of the mantissa is $< 2^{-8}$). The Newton-Raphson algorithm (shown below) can be used to further extend the mantissa's precision:

$$x[n+1] = x[n](2 - vx[n])$$

where v = the number whose reciprocal is to be found.

$x[0]$, the seed for the algorithm, is given by RCPF. For each iteration of the algorithm, the number of accurate bits in the mantissa doubles. Using RCPF, you can start with an estimate accurate to eight bits. With one iteration, accuracy is 16 bits in the mantissa, and with a second iteration, accuracy is 32 bits.

The 'C4x program to implement this algorithm is shown in Example 5–15. Each step of the algorithm is labeled along with the corresponding accuracy achieved at the end of the step. The algorithm takes only seven machine cycles.

Example 5–15. Newton-Raphson Algorithm for Computing the Reciprocal

```

RCPF  R0,R1 ; R0 = v, R1 = x[0]
;
MPYF  R1,R0,R2
SUBRF 2.0,R2
MPYF  R2,R1 ; end of first iteration (16-bit accuracy)
;
MPYF  R1,R0,R2
SUBRF 2.0,R2
MPYF  R2,R1 ; end of second iteration (32-bit accuracy)
;
;           ; R1 = 1/v
;

```

5.12 Reciprocal Square Root (RSQRF Instruction)

In many applications, normalization of data values is necessary. Often, the normalizing factor is the square root of another quantity. For example, when one vector is given, you can find the unit vector in the same direction by dividing the original vector by its own length. This involves division by a square root. The RSQRF instruction provides a simple way to directly determine this quantity instead of going through a two-step approach of finding the square root and then finding the reciprocal of the square root.

Given the result of this algorithm, the square root is found by a simple multiplication:

$$v = vx[n]$$

where $x[n]$ is the estimate of $\frac{1}{\sqrt{v}}$ as determined by the Newton-Raphson algorithm or some other algorithm.

The RSQRF instruction generates an estimated reciprocal of the square root of a floating-point number in a single cycle. It parallels some of the operational characteristics of the RCPF instruction in these ways:

- RSQRF generates an estimate (in this case, the reciprocal of the square root of a floating-point number).
- The mantissa is accurate to the eighth binary place (mantissa error is $< 2^{-8}$).
- Often, this is a satisfactory estimate of the reciprocal of a number's square root; in other cases, it may be used as a seed for an algorithm that computes the reciprocal square root to an even greater accuracy.

Figure 5–22 depicts the RSQRF algorithm. In the algorithm:

- The input is assumed to be $v = vman \times 2^{vexp}$.
- The output is assumed to be $x = xman \times 2^{xexp}$.
- $vexp + 1$ is negated and shifted right one bit with sign extension.
- If $vexp = -128$, the result is saturated to the most positive number, and the overflow flag is set.

Figure 5–22. RSQRF Instruction Algorithm

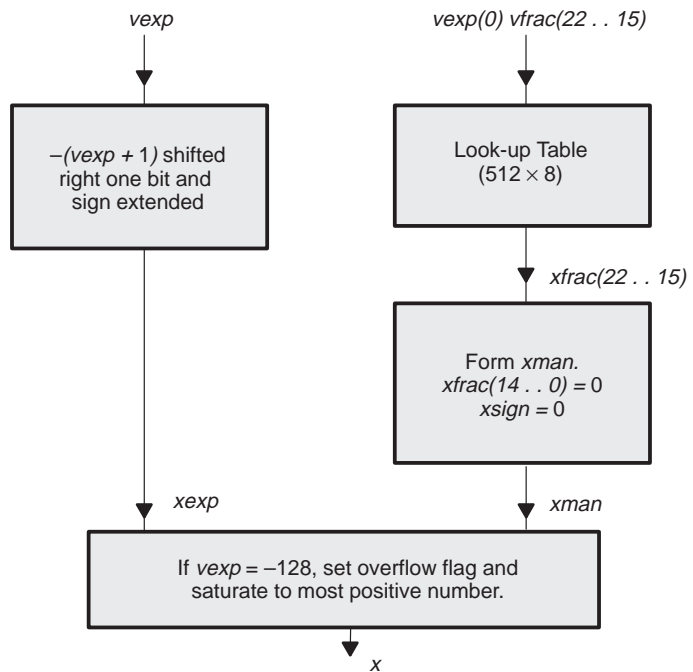

The look-up table is read by forming a nine-bit address consisting of the least significant bit of $vexp$ and bits 22–15 of $vfrac$. The eight-bit output of the look-up table forms bits 22–15 of $xfrac$. Bits 14–0 of $xfrac$ are cleared to zero. $xsign$ is set to 0. There is no provision for negative values of v .

The look-up table values are generated from simulation results.

Given the result of this algorithm, division is performed by a simple multiplication:

$$y/v = yx[n]$$

In the equation, $x[n]$ is the estimate of $1/v$ as determined by the Newton-Raphson algorithm or another algorithm.

Newton-Raphson Algorithm

The RSQRF instruction provides the reciprocal of the square root of a number. The estimate has the correct exponent and a mantissa accurate to the eighth binary place (i.e., the error of the mantissa is $< 2^{-8}$). The Newton-Raphson algorithm (shown below) can be used to further extend the mantissa's precision:

$$x[n+1] = x[n](1.5 - (v/2)x[n]x[n])$$

where v = the number whose reciprocal is to be found.

The seed for the algorithm, $x[0]$, is given by RSQRF. For each iteration of the algorithm, the number of accurate bits in the mantissa doubles. Using RSQRF, you can start with an estimate accurate to eight bits. With one iteration, accuracy is 16 bits in the mantissa, and with a second iteration, accuracy is 32 bits.

The 'C4x program to implement this algorithm is shown in Example 5–16. Each step of the algorithm is labeled, and the corresponding accuracy achieved is noted at the end of the step. The algorithm takes only ten machine cycles (compared to 30 cycles on the 'C3x without a look-up table).

Example 5–16. Newton-Raphson Algorithm for Computing the Reciprocal Square Root

```

RSQRF R0,R1 ; R0 = v, R1 = x[0]
MPYF  0.5,R0 ; R0 = v/2
;
MPYF  R1,R1,R2
MPYF  R0,R2
SUBRF 1.5,R2
MPYF  R2,R1 ; end of first iteration (16-bit accuracy)
;
MPYF  R1,R1,R2
MPYF  R0,R2
SUBRF 1.5,R2
MPYF  R2,R1 ; end of second iteration (32-bit accuracy)
;
;           ; R1 = 1/(v**0.5)
;

```

Addressing Modes

The 'C4x supports five types of addressing to access data from memory, registers, and the instruction word. This chapter details the operation, encoding, and implementation of the addressing modes.

Topic	Page
6.1 Addressing Types	6-2
6.2 Register Addressing	6-3
6.3 Direct Addressing	6-5
6.4 Indirect Addressing	6-6
6.5 Immediate Addressing	6-18
6.6 PC-Relative Addressing	6-19
6.7 Encoding of Addressing Modes	6-21
6.8 Circular Addressing	6-27
6.9 Bit-Reversed Addressing	6-32

6.1 Addressing Types

You can access data from memory, registers, and the instruction word by using five types of addressing:

- Register addressing
- Direct addressing
- Indirect addressing
- Immediate addressing
- PC-relative addressing

Not all addressing types are appropriate for all instructions. Addressing types are classified into four groups, depending upon the encoding method used:

- General addressing modes (G)
- Three-operand addressing modes (T)
- Parallel addressing modes (P)
- Conditional-branch addressing modes (B)

For use in filters and FFTs, there are two specialized modes:

- Circular addressing
- Bit-reversed addressing

6.2 Register Addressing

In register addressing, a CPU register contains the operand, as shown in this example:

```
ABSF R1 ; R1 = |R1|
```

The machine address for the CPU registers, the assembler syntax (register name), and the assigned function for those registers are listed in Table 6–1.

Table 6–1. CPU Register/Assembler Syntax and Function

(a) CPU Primary Registers

Register Name	Machine Address	Assigned Function
R0	00h	Extended-precision register 0
R1	01h	Extended-precision register 1
R2	02h	Extended-precision register 2
R3	03h	Extended-precision register 3
R4	04h	Extended-precision register 4
R5	05h	Extended-precision register 5
R6	06h	Extended-precision register 6
R7	07h	Extended-precision register 7
R8	1Ch	Extended-precision register 8
R9	1Dh	Extended-precision register 9
R10	1Eh	Extended-precision register 10
R11	1Fh	Extended-precision register 11
A0	08h	Auxiliary register 0
A1	09h	Auxiliary register 1
A2	0Ah	Auxiliary register 2
A3	0Bh	Auxiliary register 3
A4	0Ch	Auxiliary register 4
A5	0Dh	Auxiliary register 5
A6	0Eh	Auxiliary register 6

Table 6–1. CPU Register/Assembler Syntax and Function (Continued)

Register Name	Machine Address	Assigned Function
A7	0Fh	Auxiliary register 7
DP	10h	Data-page pointer
IR0	11h	Index register 0
IR1	12h	Index register 1
BK	13h	Block-size register
SP	14h	Active stack pointer
ST	15h	Status register
DIE	16h	DMA coprocessor interrupt enable
IIE	17h	Internal interrupt enable register
IIF	18h	IIOF pins and interrupt flag register
RS	19h	Repeat start address register
RE	1Ah	Repeat end address register
RC	1Bh	Repeat counter register

(b) CPU Expansion Registers

Register Name	Machine Address	Assigned Function
IVTP	00h	Interrupt-vector table pointer
TVTP	01h	Trap-vector table pointer

6.3 Direct Addressing

In direct addressing, the data address is formed by the concatenation of the 16 least significant bits of the data page pointer (DP) with the 16 least significant bits of the instruction word (expr). The use of 16 bits for the DP results in 65536 pages (64K words per page), allowing you to access a large address space without changing the value of the DP. The syntax and operation for direct addressing are listed below.

Syntax: @expr

Operation: address = DP concatenated with expr

Figure 6–1 shows the formation of the data address. Example 6–1 gives an instruction example with data before and after instruction execution.

Figure 6–1. Direct Addressing

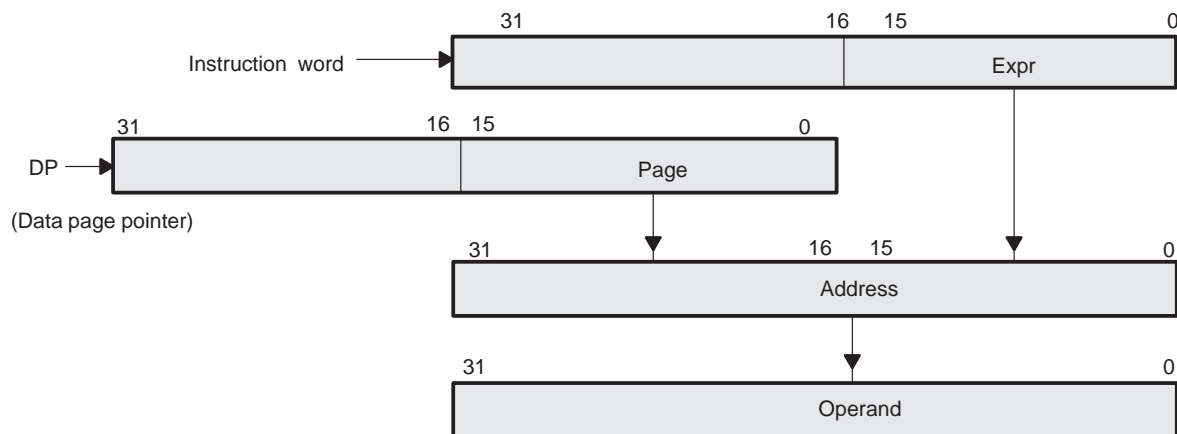

Example 6–1. Direct Addressing

ADDI @0BCDEh, R7	
Before Instruction:	After Instruction:
DP = 108Ah	DP = 108Ah
R7 = 11h	R7 = 1234 5689h
Data at 108A BCDEh = 1234 5678h	Data at 108A BCDEh = 1234 5678h

6.4 Indirect Addressing

Indirect addressing specifies the address of an operand in memory through the contents of an auxiliary register, optional displacements, and index registers. The auxiliary register arithmetic units (ARAUs) perform this unsigned arithmetic. (All 32 bits of the auxiliary and index registers are used in indirect addressing.)

The flexibility of indirect addressing is possible because the ARAUs on the 'C4x modify auxiliary registers in parallel with operations within the main CPU. Indirect addressing is specified by a five-bit field in the instruction word, referred to as the mod field (shown on the left side of Table 6–2 on as well as in the examples that follow). A displacement is either an explicit unsigned 5-bit or 8-bit integer contained in the instruction word or an implicit displacement of one. Two index registers, IR0 and IR1, can also be used in indirect addressing, enabling the use of 32-bit indirect displacements (IR0 and IR1 are treated as signed integers). In some cases, an addressing scheme using circular or bit-reversed addressing is optional. Generating addresses for circular addressing is discussed in Section 6.8, and for bit-reversed addressing in Section 6.9.

Table 6–2 lists the various kinds of indirect addressing, along with the value of the modification (mod) field, assembler syntax, operation, and function for each. Figure 6–2 shows the format of the indirect addressing operand in the instruction encoding. The *disp* field does not exist for some instructions.

Figure 6–2. Indirect Addressing Operand Encoding

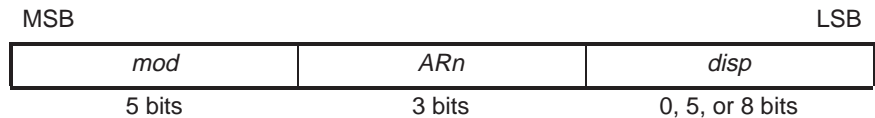

Note:

The auxiliary register (*AR_n*) to be used is encoded in the instruction word according to its binary representation, *n* (i.e., AR3 is encoded as 11₂), not its register machine address (as shown in Table 6–1).

Table 6–2. Indirect Addressing

(a) Indirect Addressing With Displacement

Mod Field	Syntax	Operation	Description
00000	*+ARn(displacement)	addr = ARn + disp	With predisplacement add
00001	*-ARn(displacement)	addr = ARn - disp	With predisplacement subtract
00010	*++ARn(displacement)	addr = ARn + disp ARn = ARn + disp	With predisplacement add and modify
00011	*--ARn(displacement)	addr = ARn - disp ARn = ARn - disp	With predisplacement subtract and modify
00100	*ARn++(displacement)	addr = ARn ARn = ARn + disp	With postdisplacement add and modify
00101	*ARn--(displacement)	addr = ARn ARn = ARn - disp	With postdisplacement subtract and modify
00110	*ARn++(displacement)%	addr = ARn ARn = circ(ARn + disp)	With postdisplacement add and circular modify
00111	*ARn--(displacement)%	addr = ARn ARn = circ(ARn - disp)	With postdisplacement subtract and circular modify

(b) Indirect Addressing With Index Register IRO

Mod Field	Syntax	Operation	Description
01000	*+ARn(IRO)	addr = ARn + IRO	With preindex (IRO) add
01001	*-ARn(IRO)	addr = ARn - IRO	With preindex (IRO) subtract
01010	*++ARn(IRO)	addr = ARn + IRO ARn = ARn + IRO	With preindex (IRO) add and modify
01011	*--ARn(IRO)	addr = ARn - IRO ARn = ARn - IRO	With preindex (IRO) subtract and modify
01100	*ARn++(IRO)	addr = ARn ARn = ARn + IRO	With postindex (IRO) add and modify
01101	*ARn--(IRO)	addr = ARn ARn = ARn - IRO	With postindex (IRO) subtract and modify
01110	*ARn++(IRO)%	addr = ARn ARn = circ(ARn + IRO)	With postindex (IRO) add and circular modify
01111	*ARn--(IRO)%	addr = ARn ARn = circ(ARn - IRO)	With postindex (IRO) subtract and circular modify

LEGEND:

addr	=	memory address	--	=	subtract and modify
ARn	=	auxiliary register AR0 - AR7	circ()	=	address in circular addressing
IRn	=	index register IRO or IR1	%	=	where circular addressing is performed
disp	=	displacement	B	=	where bit-reversed addressing is performed
++	=	add and modify			

Table 6–2. Indirect Addressing (Continued)

(c) Indirect Addressing With Index Register IR1

Mod Field	Syntax	Operation	Description
10000	*+ARn(IR1)	addr = ARn + IR1	With preindex (IR1) add
10001	*-ARn(IR1)	addr = ARn - IR1	With preindex (IR1) subtract
10010	*++ARn(IR1)	addr = ARn + IR1 ARn = ARn + IR1	With preindex (IR1) add and modify
10011	*--ARn(IR1)	addr = ARn - IR1 ARn = ARn - IR1	With preindex (IR1) subtract and modify
10100	*ARn++(IR1)	addr = ARn ARn = ARn + IR1	With postindex (IR1) add and modify
10101	*ARn--(IR1)	addr = ARn ARn = ARn - IR1	With postindex (IR1) subtract and modify
10110	*ARn++(IR1)%	addr = ARn ARn = circ(ARn + IR1)	With postindex (IR1) add and circular modify
10111	*ARn--(IR1)%	addr = ARn ARn = circ(ARn - IR1)	With postindex (IR1) subtract and circular modify

(d) Indirect Addressing (Special Cases)

Mod Field	Syntax	Operation	Description
11000	*ARn	addr = ARn	Indirect
11001	*ARn++(IR0)B	addr = ARn ARn = B(ARn + IR0)	With postindex (IR0) add and bit-reversed modify

LEGEND:

addr	=	memory address	--	=	subtract and modify
ARn	=	auxiliary register AR0 – AR7	circ()	=	address in circular addressing
IRn	=	index register IR0 or IR1	%	=	where circular addressing is performed
disp	=	displacement	B	=	where bit-reversed addressing is performed
++	=	add and modify			

Example 6–2 through Example 6–19 show the operation for each type of indirect addressing.

Example 6–2. Auxiliary Register Indirect

An auxiliary register (ARn) contains the address of the operand to be fetched.

Operation: operand address = ARn

Assembler Syntax: *ARn

Modification Field: 11000

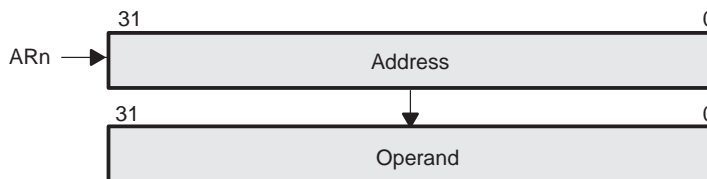

Example 6–3. Indirect With Predisplacement Add

The address of the operand to be fetched is the sum of an auxiliary register (ARn) and the displacement (disp). The displacement is either a 5-bit or 8-bit unsigned integer contained in the instruction word or an implied value of 1.

Operation: operand address = ARn + disp

Assembler Syntax: *+ARn(displacement)

Modification Field: 00000

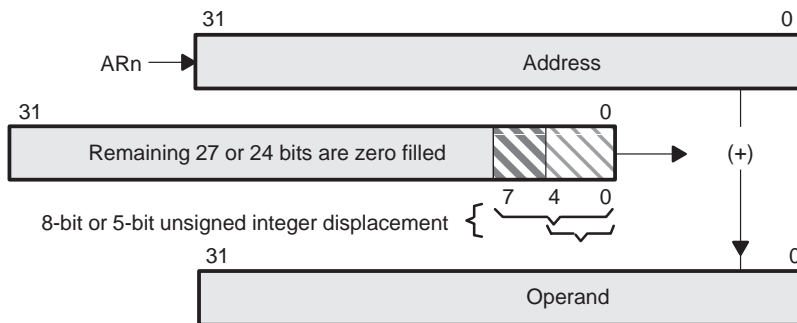

Example 6–4. Indirect With Predisplacement Subtract

The address of the operand to be fetched is the contents of an auxiliary register (ARn) minus the displacement ($disp$). The displacement is either an 8-bit unsigned integer contained in the instruction word or an implied value of 1.

Operation: operand address = $ARn - disp$
Assembler Syntax: $*-ARn(disp)$
Modification Field: 00001

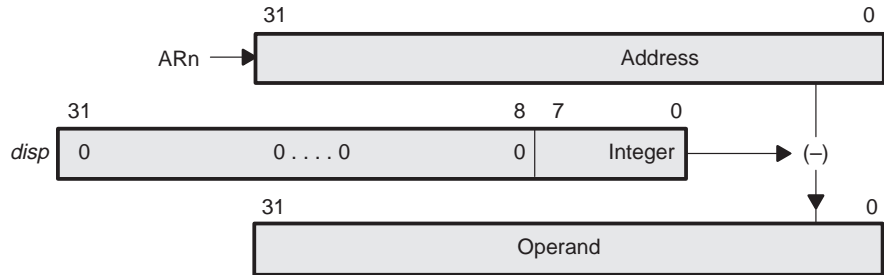

Example 6–5. Indirect With Predisplacement Add and Modify

The address of the operand to be fetched is the sum of an auxiliary register (ARn) and the displacement ($disp$). The displacement is either an 8-bit unsigned integer contained in the instruction word or an implied value of 1. After the data is fetched, the auxiliary register is updated with the generated address.

Operation: operand address = $ARn + disp$
 $ARn = ARn + disp$
Assembler Syntax: $*++ ARn(disp)$
Modification Field: 00010

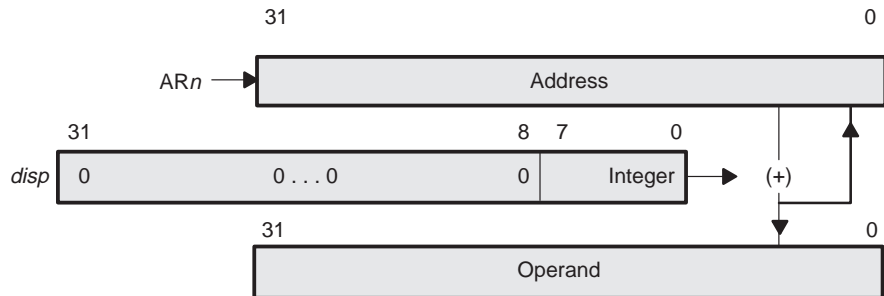

Example 6–6. Indirect With Predisplacement Subtract and Modify

The address of the operand to be fetched is the contents of an auxiliary register (AR_n) minus the displacement ($disp$). The displacement is either an 8-bit unsigned integer contained in the instruction word or an implied value of 1. After the data is fetched, the auxiliary register is updated with the generated address.

Operation: $operand\ address = AR_n - disp$
 $AR_n = AR_n - disp$

Assembler Syntax: $*--AR_n(disp)$

Modification Field: 00011

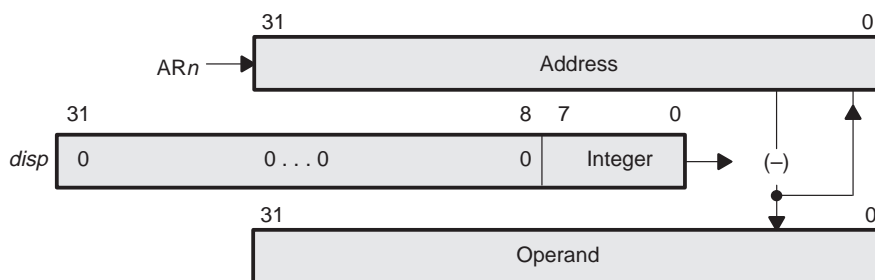

Example 6–7. Indirect With Postdisplacement Add and Modify

The address of the operand to be fetched is the contents of an auxiliary register (AR_n). After the operand is fetched, the displacement ($disp$) is added to the auxiliary register. The displacement is either an 8-bit unsigned integer contained in the instruction word or an implied value of 1.

Operation: $operand\ address = AR_n$
 $AR_n = AR_n + disp$

Assembler Syntax: $*AR_n++\ disp$

Modification Field: 00100

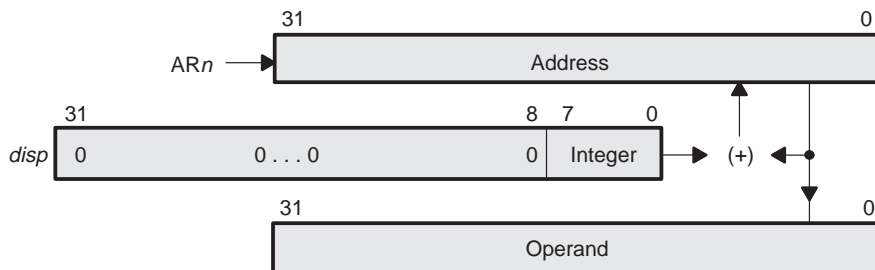

Example 6–8. Indirect With Postdisplacement Subtract and Modify

The address of the operand to be fetched is the contents of an auxiliary register (ARn). After the operand is fetched, the displacement ($disp$) is subtracted from the auxiliary register. The displacement is either an 8-bit unsigned integer contained in the instruction word or an implied value of 1.

Operation: operand address = ARn
 $ARn = ARn - disp$

Assembler Syntax: $*ARn -- disp$

Modification Field: 00101

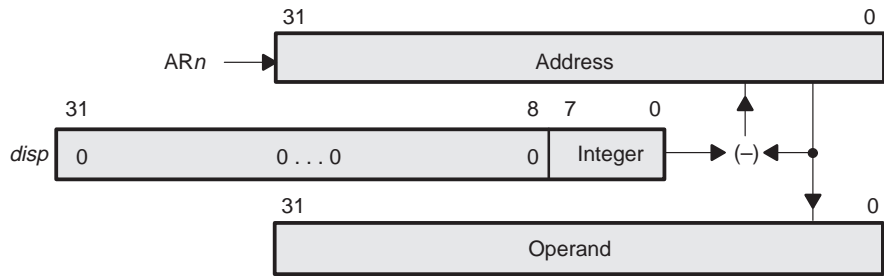

Example 6–9. Indirect With Postdisplacement Add and Circular Modify

The address of the operand to be fetched is the contents of an auxiliary register (ARn). After the operand is fetched, the displacement ($disp$) is added to the contents of the auxiliary register through circular addressing. This result is used to update the auxiliary register. The displacement is either an 8-bit unsigned integer contained in the instruction word or an implied value of 1.

Operation: operand address = ARn
 $ARn = circ(ARn + disp)$

Assembler Syntax: $*ARn ++ (disp)\%$

Modification Field: 00110

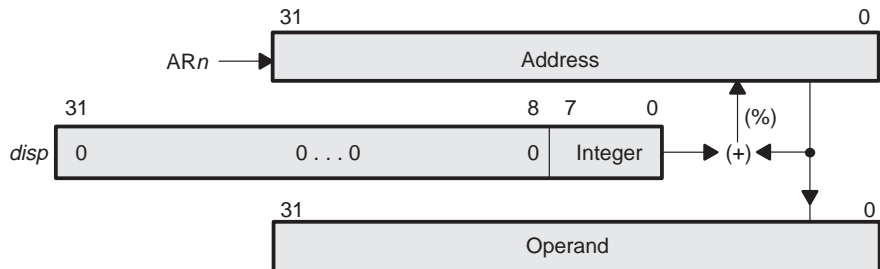

Example 6–10. Indirect With Postdisplacement Subtract and Circular Modify

The address of the operand to be fetched is the contents of an auxiliary register (ARn). After the operand is fetched, the displacement ($disp$) is subtracted from the contents of the auxiliary register through circular addressing. This result is used to update the auxiliary register. The displacement is either an 8-bit unsigned integer contained in the instruction word or an implied value of 1.

Operation: operand address = ARn
 $ARn = circ(ARn - disp)$

Assembler Syntax: $*ARn--(disp)\%$

Modification Field: 00111

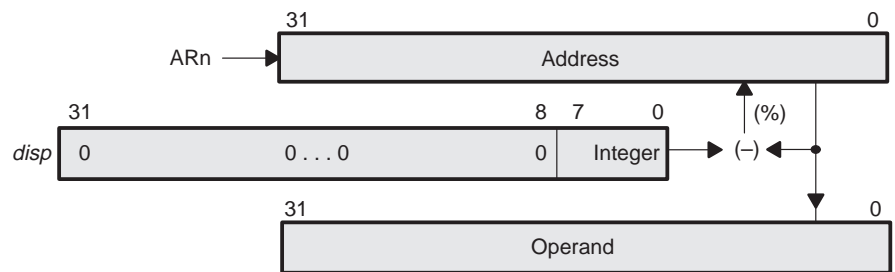

Example 6–11. Indirect With Preindex Add

The address of the operand to be fetched is the sum of an auxiliary register (ARn) and an index register ($IR0$ or $IR1$).

Operation: operand address = $ARn + IR\ m$

Assembler Syntax: $*+ARn(IRm)$

Modification Field: 01000 if $m=0$
 10000 if $m=1$

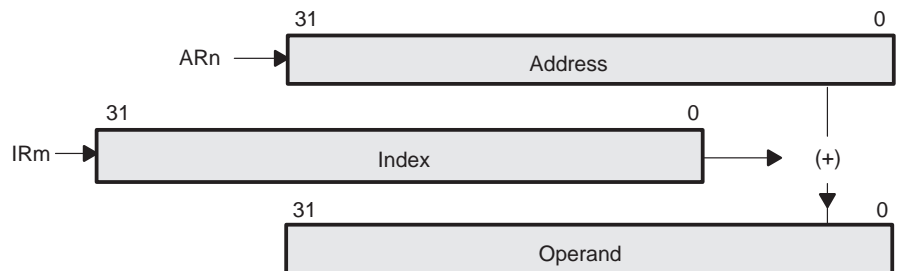

Example 6–12. Indirect With Preindex Subtract

The address of the operand to be fetched is the difference between an auxiliary register (AR_n) and an index register (IR_0 or IR_1).

Operation: operand address = $AR_n - IR_m$
Assembler Syntax: $*-AR_n(IR_m)$
Modification Field: 01001 if $m=0$
 10001 if $m=1$

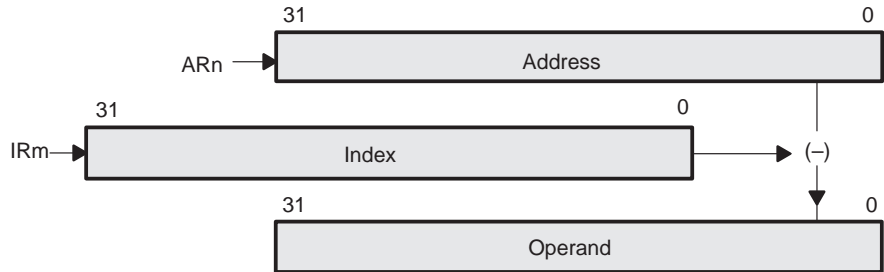

Example 6–13. Indirect With Preindex Add and Modify

The address of the operand to be fetched is the sum of an auxiliary register (AR_n) and an index register (IR_0 or IR_1). After the data is fetched, the auxiliary register is updated with the generated address.

Operation: operand address = $AR_n + IR_m$
 $AR_n = AR_n + IR_m$
Assembler syntax: $*++AR_n(IR_m)$
Modification Field: 01010 if $m=0$
 10010 if $m=1$



Example 6–14. Indirect With Preindex Subtract and Modify

The address of the operand to be fetched is the difference between an auxiliary register (ARn) and an index register ($IR0$ or $IR1$). The resulting address becomes the new contents of the auxiliary register.

Operation: operand address = $ARn - IRm$
 $ARn = ARn - IRm$

Assembler Syntax: $*--ARn(IRm)$

Modification Field: 01011 if $m=0$
 10011 if $m=1$

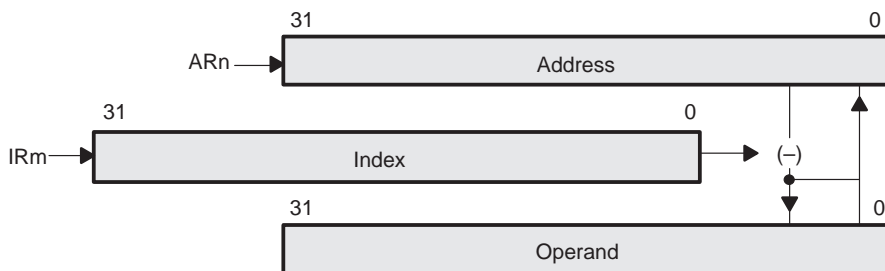
*Example 6–15. Indirect With Postindex Add and Modify*

The address of the operand to be fetched is the contents of an auxiliary register (ARn). After the operand is fetched, an index register ($IR0$ or $IR1$) is added to the auxiliary register.

Operation: operand address = ARn
 $ARn = ARn + IRm$

Assembler Syntax: $*ARn++(IRm)$

Modification Field: 01100 if $m=0$
 10100 if $m=1$

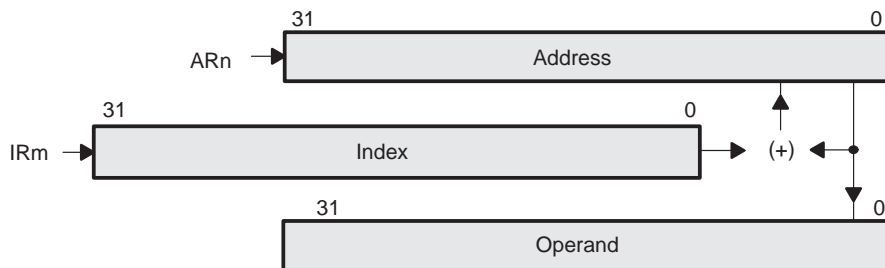

Example 6–16. Indirect With Postindex Subtract and Modify

The address of the operand to be fetched is the contents of an auxiliary register (AR_n). After the operand is fetched, the index register (IR_0 or IR_1) is subtracted from the auxiliary register.

Operation: operand address = AR_n
 $AR_n = AR_n - IR_m$

Assembler Syntax: $*AR_n--(IR_m)$

Modification Field: 01101 if $m = 0$
 10101 if $m = 1$

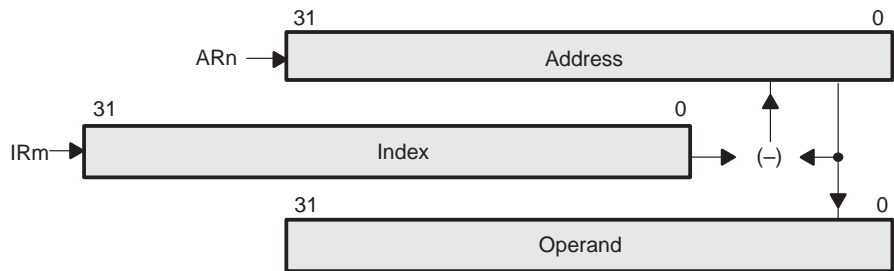

Example 6–17. Indirect With Postindex Add and Circular Modify

The address of the operand to be fetched is the contents of an auxiliary register (AR_n). After the operand is fetched, the index register (IR_0 or IR_1) is added to the auxiliary register. This value is evaluated through circular addressing and replaces the contents of the auxiliary register.

Operation: operand address = AR_n
 $AR_n = circ(AR_n + IR_m)$

Assembler Syntax: $*AR_n++(IR_m)\%$

Modification Field: 01110 if $m = 0$
 10110 if $m = 1$



Example 6–18. Indirect With Postindex Subtract and Circular Modify

The address of the operand to be fetched is the contents of an auxiliary register (ARn). After the operand is fetched, the index register (IR0 or IR1) is subtracted from the auxiliary register. The result is evaluated through circular addressing and replaces the contents of the auxiliary register.

Operation: operand address = ARn
 $ARn = \text{circ}(ARn - IRm)$

Assembler Syntax: *ARn--(IRm)%

Modification Field: 01111 if m = 0
 10111 if m = 1

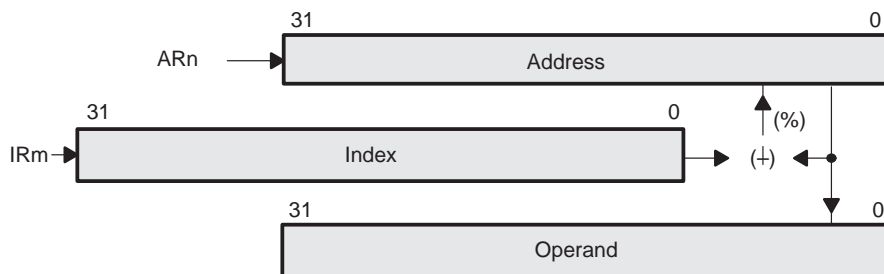
*Example 6–19. Indirect With Postindex Add and Bit-Reversed Modify*

The address of the operand to be fetched is the contents of an auxiliary register (ARn). After the operand is fetched, the index register (IR0) is added to the auxiliary register. This addition is performed with a reverse-carry propagation and can be used to yield a bit-reversed (B) address. This value replaces the contents of the auxiliary register.

Operation: operand address = ARn
 $ARn = B(ARn + IR0)$

Assembler Syntax: *ARn++(IR0)B

Modification Field: 11001

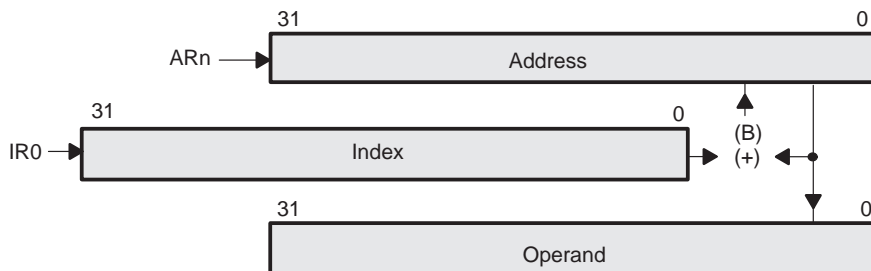

6.5 Immediate Addressing

In immediate addressing, the operand is an 8- or 16-bit immediate value contained in the 8 or 16 least significant bits of the instruction word (*expr*). Depending on the data types assumed for the instruction, the immediate operand may be a twos-complement integer, an unsigned integer, a signed integer, or a floating-point number. The syntax for this mode is as follows:

Syntax: *expr*

Example 6–20 gives an instruction example with data from before and after the instruction is executed. Notice that AND and AND3 produce different results.

Example 6–20. Immediate Addressing

Instruction	Before	After
SUBI 1 ,R0	R0=0h	R0=00 FFFF FFFFh
LDI 0FFFFh ,R0	R0=0h	R0=00 FFFF FFFFh
LDF 5.0 ,R0	R0=0h	R0=02 2000 0000h
OR 0FFFFh ,R0	R0=0h	R0=00 0000 FFFFh
AND3 80h ,R0 ,R0	R0=00 FFFF FFFFh	R0=00 FFFF FF80h
AND 80h ,R0	R0=00 FFFF FFFFh	R0=00 0000 0080h

6.6 PC-Relative Addressing

PC-relative addressing is used for branching. It adds the contents of the 16 or 24 least significant bits of the instruction word to the PC register. The assembler takes the *src* (a label or address) specified by the user and generates a displacement. If the branch is a standard branch, this displacement is equal to $[label - (instruction\ address + 1)]$. If the branch is a delayed branch, this displacement is equal to $[label - (instruction\ address + 3)]$.

The displacement is stored as a 16-bit or 24-bit signed integer in the least significant bits of the instruction word. The displacement is added to the PC during the pipeline decode phase. Notice that because the PC is incremented by one in the fetch phase, the displacement is added to this incremented PC value.

Syntax: *expr* (label or address)

Example 6–21 gives an instruction example with before- and after-instruction data.

Example 6–21. PC-Relative Addressing

BU	NEWPC	; address of BU instruction=1,
...		; NEWPC label =5, displacement = 3
NEWPC	...	; displacement = 5 - (1 + 1)
Before Instruction Decode Phase		After Instruction Execution Phase:
PC = 2h		PC = 5h

The 24-bit addressing mode is used to encode the program control instructions (e.g., BR, BRD, CALL, RPTB, RPTBD, LAJ). Depending on the instruction, the new PC value is derived by adding a 24-bit signed value in the instruction word with the present PC value. Bit 24 determines the type of branch (D = 0 for a standard branch or D = 1 for a delayed branch). Some of these instructions are encoded in Figure 6–3.

Figure 6–3. Encoding for 24-Bit PC-Relative Addressing Mode

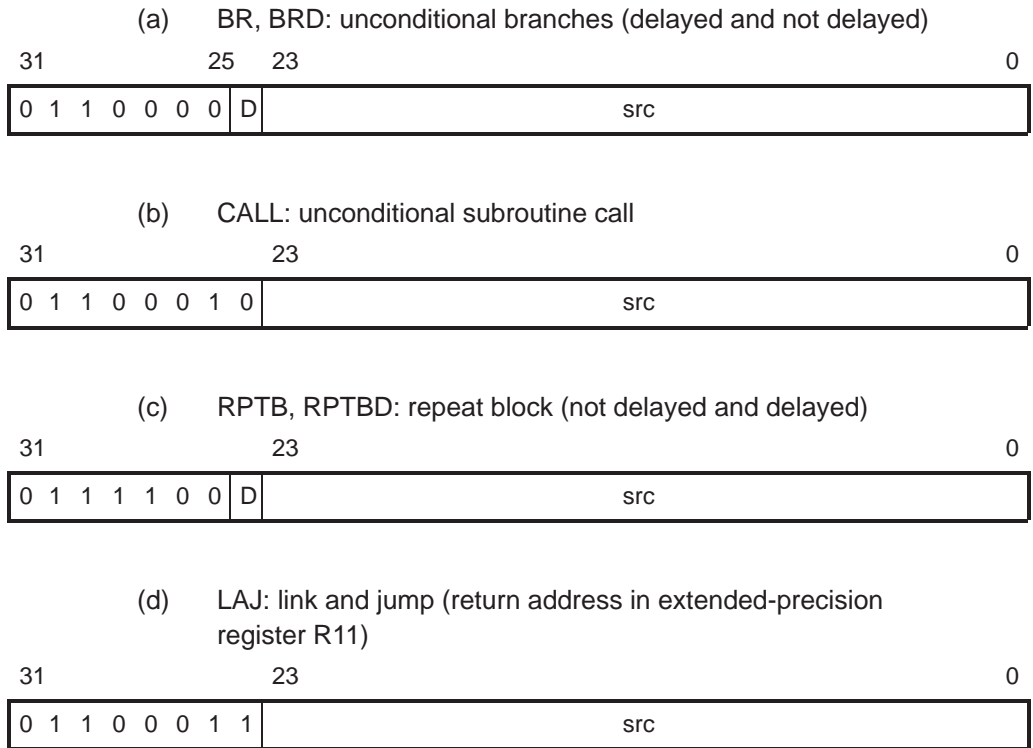

6.7 Encoding of Addressing Modes

The five addressing types form four groups of addressing modes:

- General addressing modes (G) (subsection 6.7.1)
- Three-operand addressing modes (T) (subsection 6.7.2)
- Parallel addressing modes (P) (subsection 6.7.3)
- Conditional-branch addressing modes (B) (subsection 6.7.4)

6.7.1 General Addressing Modes

Instructions that use the general addressing modes are general-purpose instructions, such as ADDI, MPYF, and LSH. Such instructions usually have the following syntax:

dst operation *src* → *dst*

In the syntax, the destination operand is signified by *dst* and the source operand by *src*; operation defines an operation to be performed with the general addressing modes to specify certain operands. Bits 31–29 are zero, indicating general addressing mode instructions. Bits 22 and 21 specify the general addressing mode (G) field, which defines how bits 15 through 0 are to be interpreted for addressing the *src* operand.

Options for bits 22 and 21 (G field) are as follows:

G	Mode
00	register (all CPU registers unless specified otherwise)
01	direct
10	indirect
11	immediate

If the *src* and *dst* fields contain register specifications, the value in these fields contains the CPU register addresses as defined by Table 6–1. For the general addressing modes, the following values of AR_n are valid for indirect addressing:

$AR_n, 0 \leq n \leq 7$

Figure 6–4 shows the encoding for the general addressing modes. The notation mod_n indicates the modification field that goes with the AR_n field. Refer to Table 6–2 for further information.

Figure 6–4. Encoding for General Addressing Modes

				G		Destination		Source Operands							
31	29	28	23	22	21	20	16	15	11	10	8	7	5	4	0
0	0	0		operation	0	0	dst	0	0	0	0	0	0	0	0
0	0	0		operation	0	1	dst	direct							
0	0	0		operation	1	0	dst	modn		ARn		disp			
0	0	0		operation	1	1	dst	Immediate							

6.7.2 Three-Operand Addressing Modes

The 19 three-operand instructions on the 'C4x use the eight addressing modes listed in Table 6–3:

Table 6–3. Three-Operand Instruction Addressing Modes

Type 1†

T	src1 addressing modes	src2 addressing modes	dst ‡
00	Register mode (any CPU register)	Register mode (any CPU register)	Rx
01	Indirect mode (<i>disp</i> = 0, 1, IR0, IR1)	Register mode (any CPU register)	Rx
10	Register mode (any CPU register)	Indirect mode (<i>disp</i> = 0, 1, IR0, IR1)	Rx
11	Indirect mode (<i>disp</i> = 0, 1, IR0, IR1)	Indirect mode (<i>disp</i> = 0, 1, IR0, IR1)	Rx

† The 'C4x recognizes either type 1 or type 2 modes; the 'C3x recognizes only type 1.

‡ Rx = any register in the CPU (primary) register file for the respective processor.

Type 2†

T	src1 addressing modes	src2 addressing modes	dst ‡
00	Register mode (any CPU register)	8-bit signed immediate	Rx
01	Register mode (any CPU register)	Indirect mode *+ARn(5-bit unsigned displacement)	Rx
10	Indirect mode *+ARn(5-bit unsigned displacement)	8-bit signed immediate	Rx
11	Indirect mode *+ARn1(5-bit unsigned displacement)	Indirect mode *+ARn2(5-bit unsigned displacement)	Rx

† The 'C4x recognizes either type 1 or type 2 modes; the 'C3x recognizes only type 1.

‡ Rx = any register in the CPU (primary) register file for the respective processor.

The object values differ for three-operand instructions, depending on the assembler used:

- The 'C3x assembler recognizes only type 1 modes and sets bits 31–28 to 0010_2 .
- The 'C4x assembler recognizes both types and sets bits 31–28 to 0010_2 for type 1 and to 0011_2 for type 2.

The three-operand instructions MPYSHI3 and MPYUHI3 are unique to the 'C4x.

All instructions except four can use all of the type 2 address modes shown in Table 6–3. The exceptions, which can use only the second and fourth address modes in type 2, are the floating-point instructions ADDF3, CMPF3, MPYF3, and SUBF3.

The remaining 15 three-operand instructions are ADDC3, ADDI3, AND3, ANDN3, ASH3, CMPI3, LSH3, MPYI3, MPYSHI3, MPYUHI3, OR3, SUBB3, SUBI3, TSTB3, and XOR3.

Note:

The suffix 3 can be omitted from a three-operand instruction mnemonic.

Bits 22 and 21 specify the three-operand addressing mode (T) field, which defines how to interpret bits 15–0 for addressing the *src* operands. Bits 15–8 define the *src1* address, and bits 7–0 define the *src2* address.

Figure 6–5 and Figure 6–6 show the encoding for 'C4x three-operand addressing (the 'C3x recognizes only the format in Figure 6–5). The notation *modm* or *modn* indicates the modification field that goes with the *ARm* or *ARn* (auxiliary register) field, respectively. Refer to Table 6–2 for further information.

The 8-bit signed immediate value supports left shifts, right shifts, and memory increment and decrement operations. The immediate value is not available for floating-point operations.

These instructions greatly help reduce code size, both assembled and compiled. They also improve performance notably in DSP and other computationally intensive applications and general-purpose code.

Figure 6–5. Encoding for Type 1 Three-Operand Addressing Modes ('C3x and 'C4x)

		T		Destination		src1				src2									
31	28	27	23	22	21	20	16	15	13	12	11	10	8	7	5	4	3	2	0
0	0	1	0	operation		0	0	dst		src1				src2					
0	0	1	0	operation		0	1	dst		modn		ARn		src2					
0	0	1	0	operation		1	0	dst		src1				modn		ARn			
0	0	1	0	operation		1	1	dst		modn		ARn		modm		ARm			

Figure 6–6. Encoding for Type 2 Three-Operand Addressing Modes ('C4x Only)

		T		Destination		src1				src2									
31	28	27	23	22	21	20	16	15	13	12	11	10	8	7	5	4	3	2	0
0	0	1	1	operation		0	0	dst		Rn				Immediate					
0	0	1	1	operation		0	1	dst		Rn				disp		ARn			
0	0	1	1	operation		1	0	dst		disp		ARn		immediate					
0	0	1	1	operation		1	1	dst		disp		ARn		disp		ARm			

6.7.3 Parallel Addressing Modes

Instructions that use parallel addressing, indicated by || (two vertical bars), allow for the greatest amount of parallelism possible. The destination operands are indicated as d1 and d2, signifying *dst1* and *dst2*, respectively (see Figure 6–4). The source operands, signified by *src1* and *src2*, use the extended-precision registers. The parallel operation to be performed is called operation.

Figure 6–7. Encoding for Parallel Multiply With ADD/SUB

31	30	29	26	25	24	23	22	21	19	18	16	15	11	10	8	7	3	2	0
1	0	operation	P	d1	d2	src1		src2		modn		ARn		modm		ARm			

The parallel addressing mode (P) field specifies how to use the operands, i.e., whether they are source or destination. The specific relationship between the P field and the operands is detailed in the description of the individual parallel instructions (see Chapter 14 for more information). However, the operands are always encoded in the same way. Bits 31 and 30 are set to the value of 10, indicating parallel addressing mode instructions. Bits 25 and 24 specify the parallel addressing mode (P) field, which defines how bits 21–0 are to be interpreted for addressing the *src* operands. Bits 21–19 define the *src1* address, bits 18–16 define the *src2* address, bits 15–8 the *src3* address, and bits 7–0 the *src 4* address. The notations *modn* and *modm* indicate the modification

field that goes with the ARn or ARm (auxiliary register) field, respectively. The parallel addressing operands are listed below.

$src1 = Rn$	$(0 \leq n \leq 7$ for extended-precision registers R0–R7)
$src2 = Rn$	$(0 \leq n \leq 7$ for extended-precision registers R0–R7)
$d1$	If 0, $dst1$ is R0. If 1, $dst1$ is R1.
$d2$	If 0, $dst2$ is R2. If 1, $dst2$ is R3.
P	$0 \leq P \leq 3$
$src3$	indirect ($disp = 0, 1, IR0, IR1$)
$src4$	indirect ($disp = 0, 1, IR0, IR1$)

Note:

Only registers R0–R7 are used in parallel instructions. R8–R11 are not used in parallel instructions.

As in the three-operand addressing mode, indirect addressing in the parallel addressing mode allows for displacements of 0 or 1 and the use of the index registers (IR0 and IR1). The displacement of 1 is implied and is not explicitly coded in the instruction word.

In the encoding shown for this mode in Figure 6–7, if the $src3$ and $src4$ fields use the same auxiliary register, both addresses are correctly generated, but only the value created by the $src3$ field is saved in the specified auxiliary register. The assembler issues a warning if you specify the same auxiliary register $src3$ and $src4$.

6.7.4 Conditional-Branch Addressing Modes

Instructions using the conditional-branch addressing modes ($Bcond$, $BcondD$, $CALLcond$, $DBcond$, and $DBcondD$) can perform a variety of conditional operations. Bits 31–27 are set to the value of 01101, indicating conditional-branch addressing mode instructions. Bit 26 is set to 0 or 1; 0 selects $DBcond$, and 1 selects $Bcond$. Bit 25 determines the conditional-branch addressing mode (B). If $B = 0$, register addressing is used; if $B = 1$, PC-relative addressing is used. Bit 21 sets the type of branch: $D = 0$ for a standard branch, and $D = 1$ for a delayed branch. The condition field ($cond$) specifies the condition checked to determine what action to take — for example, whether or not to branch (see Table 14–8 on page 14-14 for a list of condition codes). Figure 6–6 shows the encoding for conditional-branch addressing.

Figure 6–8. Encoding for Conditional-Branch Addressing Modes

DBcond (D):

3	26	25	24	22	21	20	16	15	5	4	0																		
0	1	1	0	1	1	B	AR n	D	cond	0	0	0	0	0	0	0	0	0	0	0	0	0	0	0	0	0	0	0	src reg
0	1	1	0	1	1	B	AR n	D	cond	Immediate (PC relative)																			

Bcond (D):

31	26	25	24	22	21	20	16	15	5	4	0																				
0	1	1	0	1	0	B	0	0	0	D	cond	0	0	0	0	0	0	0	0	0	0	0	0	0	0	0	0	0	0	0	src reg
0	1	1	0	1	0	B	0	0	0	D	cond	Immediate (PC relative)																			

CALLcond:

31	26	25	24	22	21	20	16	15	5	4	0																				
0	1	1	1	0	0	B	0	0	0	D	cond	0	0	0	0	0	0	0	0	0	0	0	0	0	0	0	0	0	0	0	src reg
0	1	1	1	0	0	B	0	0	0	D	cond	Immediate (PC relative)																			

6.8 Circular Addressing

Many DSP algorithms require a circular buffer in memory. In convolution and correlation, a circular buffer acts as a sliding window that contains the most recent data to be processed. As new data is brought in, the new data overwrites the oldest data. The key to using a circular buffer is the implementation of a circular addressing mode. This section describes the circular addressing mode of the 'C4x.

The block-size register (BK) specifies the size of the circular buffer. If the most significant bit equal to 1 in the BK register is labeled bit N , with $N \leq 15$, the address immediately following the bottom of the circular buffer can be found by concatenating bits 31 through $N+1$ of a user-selected register (AR_n) with bits N through 0 of the BK register. The address of the top of the buffer is referred to as the effective base (EB) and can be found by concatenating bits 31 through $N+1$ of AR_n . Bits N through 0 of EB are zero.

Figure 6–9 illustrates the relationships among the block-size register (BK), the auxiliary registers (AR_n), the bottom of the circular buffer, the top of the circular buffer, and the index into the circular buffer.

A circular buffer of size R must start on a K -bit boundary (that is, the K LSBs of the starting address of the circular buffer must be zeros), where K is an integer such that $2^K > R$. Since the value R must be loaded into the BK register, $K \geq N+1$. For example, a 31-word circular buffer must start at an address whose five LSBs are 0 (that is, xxx...x00000), and the value must be loaded into the BK register.

Note:

If the BK register has a value of 0, circular addressing is not performed. The effect will be the generation of a conventional linear address.

Figure 6–9. Register Relationships in Circular Addressing

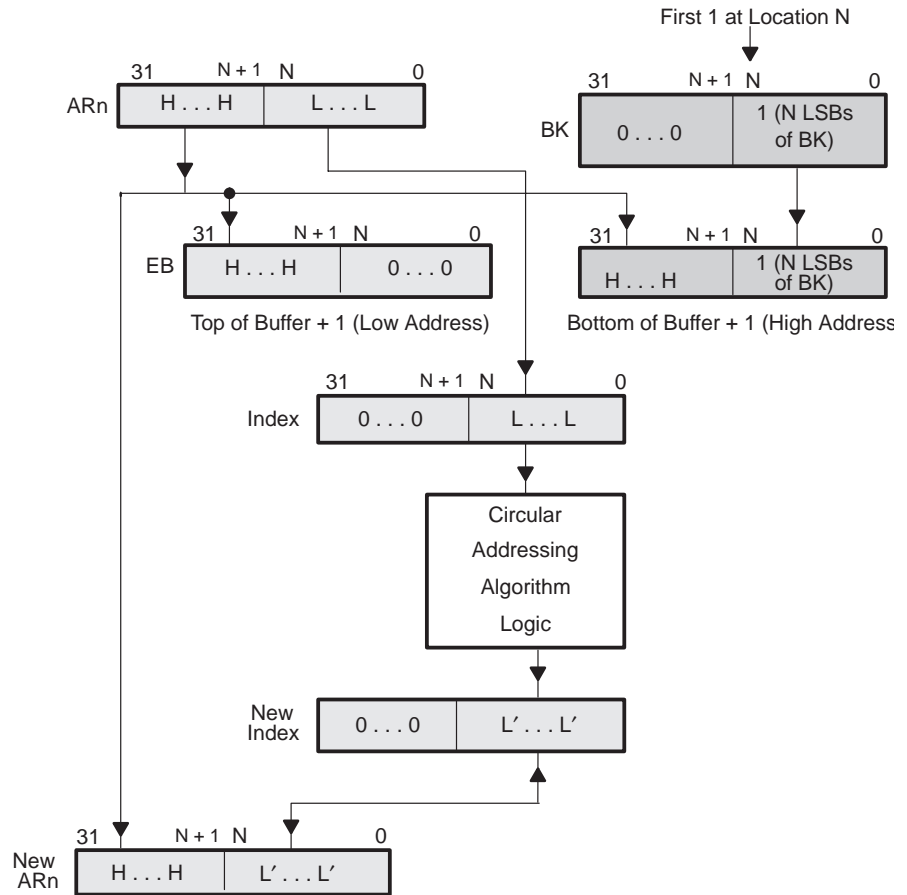

LEGEND:

- | | |
|----------------------------|---|
| ARn = auxiliary register n | L = low-order bits |
| BK = block-size register | L' = new low-order bits |
| EB = effective base | LSB = least significant bit |
| H = high-order bits | N = location of the MSB equal to 1 in the BK register |

In circular addressing, index refers to the N LSBs of the auxiliary register selected, and step is the quantity being added to or subtracted from the auxiliary register. When you use circular addressing, follow two basic rules:

- ❑ The step used must be less than or equal to the block size and is treated as an unsigned integer.
- ❑ The first time the circular queue is addressed, the auxiliary register must be pointing to an element in the circular queue.

The algorithm for circular addressing is as follows:

If $0 \leq \text{index} + \text{step} < \text{BK}$:
 $\text{index} = \text{index} + \text{step}$.
 Else if $\text{index} + \text{step} \geq \text{BK}$:
 $\text{index} = \text{index} + \text{step} - \text{BK}$.
 Else if $\text{index} + \text{step} < 0$:
 $\text{index} = \text{index} + \text{step} + \text{BK}$.

Figure 6–10 shows how the circular buffer is implemented. It illustrates the relationship of the generated quantities and the elements in the circular buffer.

Figure 6–10. Circular Buffer Implementation

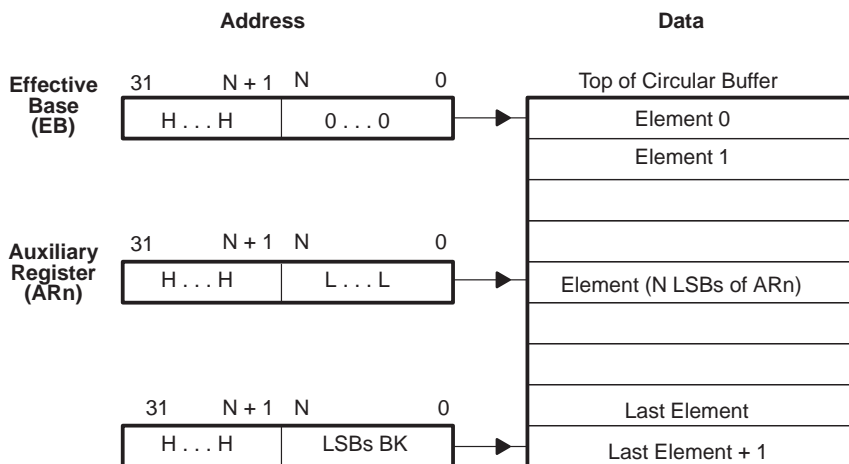
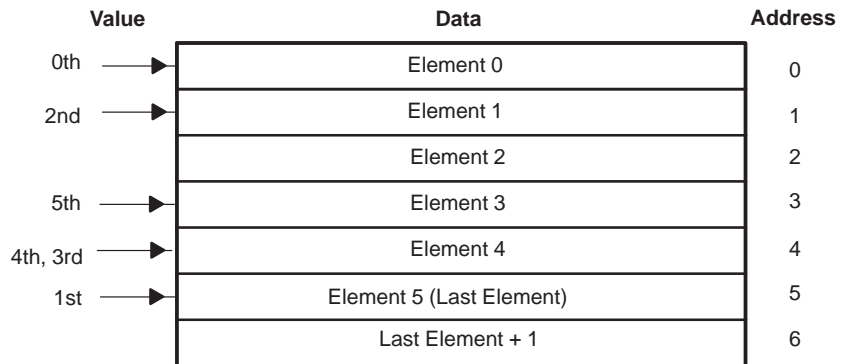

Figure 6–11 gives an example of the operation of circular addressing. Assuming that all registers are four bits, let $BK = 0110_2$ (block size of 6) and $AR0 = 0000_2$ (at least the 3 LSBs of $AR0$ should be 0). This example shows a sequence of modifications and the resulting value of $AR0$. It also shows how the pointer steps through the circular queue with a variety of step sizes (both incrementally and decrementally).

Figure 6–11. Circular Addressing Example

```

*AR0++(5)%      ; AR0 = 0   (0th value)
*AR0++(2)%      ; AR0 = 5   (1st value)
*AR0--(3)%      ; AR0 = 1   (2nd value)
*AR0++(6)%      ; AR0 = 4   (3rd value)
*AR0--(1)%      ; AR0 = 4   (4th value)
*AR0            ; AR0 = 3   (5th value)
    
```



Circular addressing is especially useful for the implementation of FIR filters. Figure 6–12 shows one possible data structure for FIR filters. Note that the initial value of AR0 points to $h(N-1)$, and the initial value of AR1 points to $x(0)$. Circular addressing is used in the 'C4x code for the FIR filter shown in Example 6–22.

Figure 6–12. Data Structure for FIR Filters

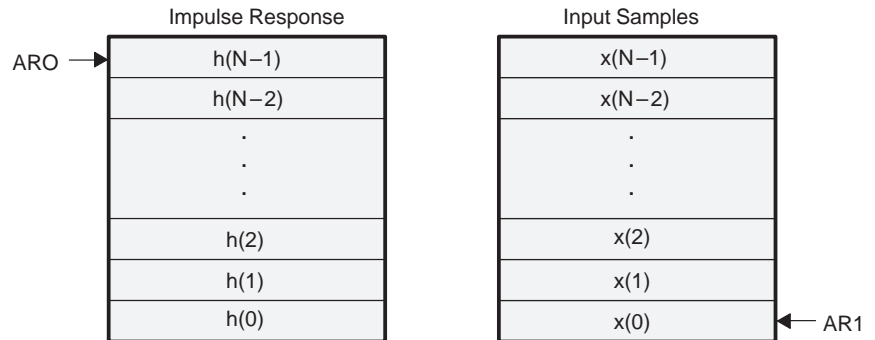

Example 6–22. FIR Filter Code Using Circular Addressing

```

* Initialization
*
    LDI    N,BK           ; Load block size.
    LDI    H,AR0         ; Load pointer to impulse response.
    LDI    X,AR1         ; Load pointer to bottom of input
*                               ; sample buffer.
*
TOP  LDF    IN, R3        ; Read input sample.
     STF    R3,*AR1++%   ; Store with other samples.
                               ; and point to top of buffer.
     LDF    0,R0         ; Initialize R0.
     LDF    0,R2         ; Initialize R2.
*
* Filter
*
     RPTS   N-1          ; Repeat next instruction.
     MPYF3 *AR0++%,*AR1++%,R0
||  ADDF3  R0,R2,R2      ; Multiply and accumulate.
     ADDF   R0,R2        ; Last product accumulated.
*
     STF    R2,Y         ; Save result.
     B     TOP           ; Repeat.

```

6.9 Bit-Reversed Addressing

The 'C4x can implement fast Fourier transforms (FFT) with bit-reversed addressing. If the data to be transformed is in the correct order, the final result of the FFT is in bit-reversed order. To recover the frequency-domain data in the correct order, certain memory locations must be swapped. The bit-reversed addressing mode makes swapping unnecessary. The next time data must be accessed, it is accessed in a bit-reversed manner rather than sequentially. In the 'C4x, this bit-reversed addressing can be implemented with both the CPU and DMA.

For correct CPU (or DMA) bit-reverse operation, the base address of bit-reversed addressing must be located on a boundary of the size of the FFT table. The CPU bit-reverse operation can be illustrated by assuming an FFT table of size $N = 2^n$. When real and imaginary data are stored in separate arrays, the n LSBs of the base address must be zero, and IR0 must be equal to 2^{n-1} (half of the FFT size). When real and imaginary data are stored in consecutive memory locations (*Re-Im-Re-Im*), the $n + 1$ LSBs of the base address must be zero, and IR0 must be equal to 2^n (FFT size).

For CPU bit-reversing, one auxiliary register (AR2 in this case) points to the physical location of a data value. When you add IR0 to this auxiliary register by using bit-reversed addressing, addresses are generated in a bit-reversed fashion (reverse carry propagation). The largest index for bit-reversed addressing is 0008 0000h; this index is treated as an unsigned integer.

To illustrate bit reversed addressing, assume 8-bit auxiliary registers. Let AR2 contain the value $0110\ 0000_2$ (96_{10}). This is the base address of the data in memory. Let IR0 contain the value $0000\ 1000_2$ (8_{10}). Example 6–23 shows a sequence of modifications of AR2 and the resulting values of AR2.

Example 6–23. Bit-Reversed Addressing Example

*AR2++(IR0)B ;	AR2=	0110 0000	(0th value)
*AR2++(IR0)B ;	AR2=	0110 1000	(1st value)
*AR2++(IR0)B ;	AR2=	0110 0100	(2nd value)
*AR2++(IR0)B ;	AR2=	0110 1100	(3rd value)
*AR2++(IR0)B ;	AR2=	0110 0010	(4th value)
*AR2++(IR0)B ;	AR2=	0110 1010	(5th value)
*AR2++(IR0)B ;	AR2=	0110 0110	(6th value)
*AR2	;	AR2=	0110 1110 (7th value)

Table 6–4 shows the relationship of the index steps and the four LSBs of AR2. You can find the four LSBs by reversing the bit pattern of the steps.

Table 6–4. Index Steps and Bit-Reversed Addressing

Step	Bit Pattern	Bit-Reversed Pattern	Bit-Reversed Step
0	0000	0000	0
1	0001	1000	8
2	0010	0100	4
3	0011	1100	12
4	0100	0010	2
5	0101	1010	10
6	0110	0110	6
7	0111	1110	14
8	1000	0001	1
9	1001	1001	9
10	1010	0101	5
11	1011	1101	13
12	1100	0011	3
13	1101	1011	11
14	1110	0111	7
15	1111	1111	15

Note:

Bit-reverse operation of the DMA coprocessor is covered in Chapter 11 of this user's guide and in the *TMS320C4x General-Purpose Applications User's Guide*.

Program Flow Control

The 'C4x provides a complete set of constructs that allow software and hardware control of the program flow. Software control includes repeats, branches, calls, traps, and returns. Hardware control includes interrupts. You can select the constructs best suited for your particular application.

Topic	Page
7.1 Repeat Mode	7-2
7.2 Delayed Branches	7-9
7.3 Calls, Traps, Branches, Jumps, and Returns	7-12
7.4 Interrupts	7-15
7.5 Traps	7-24
7.6 DMA Interrupts	7-26
7.7 Reset	7-29

7.1 Repeat Mode

The repeat mode of the 'C4x can implement zero-overhead looping. For many algorithms, most execution time is spent in an inner kernel of code. Using the repeat modes allows these time-critical sections of code to be executed in the shortest possible time.

The 'C4x provides three instructions to support zero-overhead looping: RPTB (repeat a block of code), RPTBD (repeat a block of code delayed) and RPTS (repeat a single instruction):

- RPTB and RPTBD cause a block of code to be repeated a specified number of times.
- RPTS causes a single instruction to be repeated a number of times and reduces bus traffic by fetching the instruction only once.

RPTB and RPTS are four-cycle instructions; these four cycles of overhead are incurred only on the first pass through the loop. All subsequent passes through the loop are accomplished with zero cycles of loop overhead. RPTBD is a one-cycle instruction.

Three registers (RS, RE, and RC) control the updating of the program counter when it is updated in a repeat mode, as described in Table 7–1 below.

Table 7–1. Repeat-Mode Registers

Register	Function
RS	Repeat start address register. Holds the address of the first instruction of the code block to be repeated.
RE	Repeat end address register. Holds the address of the last instruction of the code block to be repeated. RE should be greater than or equal to RS (see subsection 7.1.2).
RC	Repeat-count register. Contains one less than the number of times remaining for the code block to be repeated.

Correct operation of the repeat modes requires that all of the above registers and status register fields be initialized correctly. RPTB, RPTBD, and RPTS perform this initialization in slightly different ways (see subsection 7.1.3 and subsection 7.1.4 for more information).

7.1.1 Control Bits

Two bits are important to the operation of RPTB, RPTBD and RPTS:

- The **RM** (repeat-mode flag) bit in the status register specifies whether or not the processor fetches instructions during the repeat mode.
 - If $RM = 0$, fetches are not made in repeat mode.
 - If $RM = 1$, fetches are made in repeat mode.
- The **S bit** is internal to the processor and cannot be programmed, but this bit is necessary to fully describe the operation of RPTB, RPTBD, and RPTS.
 - If $RM = 1$ and $S = 0$, RPTB or RPTBD is executing. Program fetches occur from memory.
 - If $RM = 1$ and $S = 1$, RPTS is executing. After the first fetch (from memory), program fetches occur from the instruction register (IR).

7.1.2 Repeat-Mode Operation

Information in the repeat-mode registers and associated control bits is used to control the modification of the PC when instruction fetches are being made in repeat mode. The repeat modes compare the contents of the RE register (repeat end address register) with the program counter (PC) after the execution of each instruction. If they match and the repeat counter is nonnegative, the repeat counter is decremented, the PC is loaded with the repeat start address, and processing continues. The fetches and appropriate status bits are modified as necessary. Note that the repeat counter (RC) is never modified when the repeat-mode flag (RM) is 0.

The repeat counter should be loaded with a value one less than the number of times to execute the block; for example, an RC value of 4 would execute the block five times. The detailed algorithm for the update of the PC is shown in Example 7-1.

Notes:

- 1) The maximum number of repeats occurs when $RC = 8000\ 0000h$. This results in $8000\ 0001h$ repetitions. The minimum number of repeats occurs when $RC = 0$. This results in one repetition.
 - 2) RE should be greater than or equal to RS ($RE \geq RS$). Otherwise, the code will not repeat even though the RM bit remains set to 1.
 - 3) By writing a 0 into the repeat counter or writing 0 into the RM bit of the status register, you can stop the the loop before it completes.
-

Example 7–1. Repeat-Mode Control Algorithm

```

if RM == 1 ;If in repeat mode (RPTB or RPTS)
  if S == 1 ;If RPTS
    if first time through ;If this is the first fetch
      fetch instruction from memory ;Fetch instruction from memory
    else ;If not the first fetch
      fetch instruction from IR ;Fetch instruction from IR
      RC - 1 → RC ;Decrement RC
      if RC < 0 ;If RC is negative
        ;Repeat single mode completed
        0 → ST(RM) ;Turn off repeat mode bit
        0 → S ;Clear S
        PC + 1 → PC ;Increment PC
      else if S == 0 ;If RPTB
        fetch instruction from memory ;Fetch instruction from memory
        if PC == RE ;If this is the end of the block
          RC - 1 → RC ;Decrement RC
          if RC ≥ 0 ;If RC is not negative
            RS → PC ;Set PC to start of block
          else if RC < 0 ;If RC is negative
            0 → ST(RM) ;Turn off repeat mode bits
            0 → S ;Clear S
            PC + 1 → PC ;Increment PC

```

7.1.3 RPTB and RPTBD Instructions

The RPTB and RPTBD instructions repeat a block of code a specified number of times. RPTBD is a delayed form of the RPTB instruction that allows placing three instructions after it. These three instructions are not part of the block that is repeated, but they execute before the block repeat is started. This way, the pipeline remains full, and the RPTBD instruction can execute in one cycle.

The number of times to repeat the block is the RC (repeat count) register value plus one. Because the execution of RPTB and RPTBD does not load the RC, you must load this register yourself. The RC register must be loaded before the RPTB/RPTBD instruction is executed. *The RC register should not be loaded in the 3 instructions after RPTBD.* Example 7–2 shows a typical setup of the block repeat operation.

Example 7–2. RPTB Operation

```

LD 15,RC ; Load repeat counter with 15
RPTB ENDLOP ; Execute the block of code
STLOOP ;from STLOOP to ENDLOP 16 times
.
.
.
ENDLOP

```

All block repeats initiated by RPTB or RPTBD can be interrupted. However, interrupts are disabled during the execution of the three instructions following an RPTBD. None of the three instructions after the RPTBD instruction should modify the PC register or program flow. This restriction also applies to delayed branches, as explained in Section 7.2.

When RPTB *src* or RPTBD *src* execute, they perform a sequence of four operations:

- 1) Load the start address of the block into RS (repeat start address register).
 - For **RPTB**, this is the next address following the instruction:
PC of RPTB + 1 → RS
 - For **RPTBD**, this is the fourth address following the instruction:
PC of RPTBD + 4 → RS
- 2) Load the end address of the block into RE (repeat end address register).
 - For **RPTB**, in *PC-relative mode*, the 24-bit *src* operand plus RS is the end address:
 $src + PC \text{ of RPTB} + 1 \rightarrow RE$
 - For **RPTBD**, in *PC-relative mode*, the 24-bit source operand plus RS is the end address:
 $src + PC \text{ of RPTBD} + 3 \rightarrow RE$
- 3) In *register mode*, the contents of the *src* register is the end address:
contents of *src* register → RE
- 4) Set the status register to indicate the repeat mode of operation.
1 → RM status register bit (repeat mode flag)
- 5) Indicate that this is the repeat block mode of operation.
0 → S bit (bit is internal to the processor and not programmable)

7.1.4 RPTS Instruction

A RPTS *src* instruction repeats the instruction following the RPTS (*src* +1) times. Repeats of a single instruction initiated by RPTS are not interruptible since RPTS fetches the instruction word only once and then keeps it in the instruction register for reuse. An interrupt in this situation would cause the instruction word to be lost. Refetching the instruction word from the instruction register reduces memory accesses and, in effect, acts as a one-word program cache. If you need a single instruction that is repeatable and interruptible, you can use the RPTB/RPTBD instruction.

When RPTS *src* is executed, a sequence of five operations occurs:

- 1) PC + 1 → RS
- 2) PC + 1 → RE
- 3) 1 → RM (status register bit)
- 4) 1 → S
- 5) *src* → RC (repeat count register)

The RPTS instruction loads all registers and mode bits necessary for the operation of the single instruction repeat mode. Step 1 loads the start address of the block into RS. Step 2 loads the end address into the RE (end address of the block). Since this is a repeat of a single instruction, the start address and the end address are the same. Step 3 sets the status register to indicate the repeat mode of operation. Step 4 indicates that this is the repeat single-instruction mode of operation. Step 5 loads *src* into RC.

7.1.5 Repeat Mode Restriction Rules

Because the block repeat modes modify the program counter, other instructions cannot modify the program counter at the same time. Two rules apply:

Rule 1: The last instruction in the block (or the only instruction in a block of size one) cannot be a *Bcond*, *DBcond*, *CALL*, *CALLcond*, *TRAPcond*, *RETIcond*, *RETScond*, *IDLE*, *RPTB*, or *RPTS*. Example 7–3 shows an incorrectly placed standard branch.

Rule 2: None of the last four instructions from the bottom of the block (nor the only instruction in a block of size one) can be a *BcondD*, *BRD*, or *DBcondD*, *RPTBD*, *LAJ*, *LAJcond*, *LATcond*, *BcondAF*, *BcondAT*, or *RETIcondD*. Example 7–4 shows an incorrectly placed delayed branch.

If either of these rules is violated, the PC will be undefined.

Example 7–3. Incorrectly Placed Standard Branch

```

                LDI    15,RC    ; Load repeat counter with 15
                RPTB   ENDLOP   ; Execute block of code
STLOOP          ; from STLOOP to ENDLOP 16 times
                .
                .
                .
ENDLOP          BR    OOPS     ; This branch violates rule 1
    
```

Example 7–4. Incorrectly Placed Delayed Branch

```

        LDI    15,RC    ; Load repeat counter with 15
        RPTB  ENDLOP   ; Execute block of code
STLOOP          ; from STLOOP to ENDLOP 16 times
        .
        .
        .
        BRD   OOPS     ; This branch violates rule 2
        ADDF
        MPYF
ENDLOP  SUBF

```

7.1.6 RC Register Value After Repeat Mode Completes

For the RPTB/RPTBD instruction, the RC register normally decrements to 0000 0000h, unless the block size is 1; in that case, it decrements to FFFF FFFFh. However, if the RPTB/RPTBD instruction with a block size of 1 has a pipeline conflict in the instruction being executed, the RC register decrements to 0000 0000h. Example 7–5 illustrates a pipeline conflict. Refer to Chapter 8 for pipeline information.

RPTS normally decrements the RC register to FFFF FFFFh. However, if the RPTS has a pipeline conflict on the last cycle, the RC register decrements to 0000 0000h.

In any case, the number of repetitions is always RC + 1, regardless of the final value of RC.

Example 7–5. Pipeline Conflict in a RPTB Instruction

```

EDC    .word 40000000h ; Program is located in 4000000Fh
        LDP    EDC
        LDI    @EDC,AR0
        LDI    15,RC    ; Load repeat counter with 15
        RPTB  ENDLOP   ; Execute block of code
ENDLOP LDI    *AR0,R0   ; The *AR0 read conflicts with
                        ; the instruction fetching.
                        ; Then RC decrements to 0. If
                        ; cache is enabled, RC decrements
                        ; to FFFF FFFFh

```

7.1.7 Nesting Block Repeats

Block repeats (RPTB and RPTBD) are nestable. Because all of the control of a block repeat is defined by the RS, RE, RC, and ST registers, these registers must be saved and stored to nest block repeats. For example, if you write an interrupt service routine that requires the use of RPTB or RPTBD, it is possible that the interrupt associated with the routine may occur during another block repeat. The interrupt service routine can check the RM bit to determine whether the block repeat mode is active. If RM is set, the interrupt routine should save ST, RS, RE and RC, in this order. The interrupt routine can then perform a block repeat. Before returning from the interrupted routine, the interrupt routine should restore RC, RE, RS, and ST, in this order. If the RM bit is not set, you do not need to save and restore these registers.

The RPTS instruction can also be used in a block repeat loop if the proper registers are saved.

Because the program counter is modified at the end of the loop according to the contents of registers RS, RE, and RC, no operation should attempt to modify the repeat counter or the program counter to a different value at the end of the loop.

It takes four cycles of overhead to save and restore these registers. Hence, sometimes, it may be more economical to implement a nested loop by the more traditional method of using a register as a counter and then using a delayed branch, rather than by using the nested repeat block approach. Often, implementing the outer loop as a counter and the inner loop as a RPTB/RPTBD instruction produces the fastest execution.

Note:

The order in which the registers are saved/restored is important to guarantee correct operation. The ST register should be restored last, after the RC, RE, and RS registers. ST should be restored after restoring RC, because the RM bit cannot be set to one if the RC register is 0 or -1. For this reason, if you execute a POP ST instruction (with ST(RM) = 1) while RC = 0, the POP instruction recovers all of the ST register bits except the RM bit, which stays at 0 (repeat mode disabled). Also, RS and RE should be correctly set before you activate the repeat mode.

Section 1.7, *Repeat Modes*, in the *TMS320C4x General-Purpose Applications User's Guide* contains examples of how to use repeat-mode instructions.

7.2 Delayed Branches

The 'C4x offers two main types of branches: standard and delayed.

Standard branches empty the pipeline before performing the branch; this guarantees correct management of the program counter and results in a 'C4x branch taking four cycles. Included in this class are standard branches (*Bcond*), repeats, calls, returns, and traps.

Delayed branches do not empty the pipeline but guarantee that the next three instructions will execute before the program counter is modified by the branch. The result is a branch that requires only a single cycle, thus making the speed of the delayed branch very close to speed of the optimal block repeat modes of the 'C4x. However, unlike block repeat modes, delayed branches can be used in situations other than looping. Every delayed branch has a standard branch counterpart that is used when a delayed branch cannot be used.

Conditional delayed branches use the conditions, reflected in the status register, that existed at the end of the instruction preceding the branch. They do not depend upon the instructions following the delayed branch. The execution time of a conditional delayed branch instruction is the same regardless of whether or not the branch is taken.

When a delayed branch is fetched, it remains pending until the three instructions that follow are executed. None of the three instructions immediately after a delayed branch can be any of the following:

<i>Bcond</i>	<i>DBcond</i>	LAJ	<i>RETScond</i>
<i>BcondD</i>	<i>DBcondD</i>	LAJ <i>cond</i>	RPTB
<i>BcondAF</i>	CALL	LAT <i>cond</i>	RPTBD
<i>BcondAT</i>	CALL <i>cond</i>	RETI <i>cond</i>	RPTS
BR	IDLE	RETI <i>condD</i>	TRAP <i>cond</i>
BRD			

This restriction also applies to the RPTBD instruction, covered in subsection 7.1.3.

Delayed branches disable interrupts until the three instructions following the delayed branch are completed. This is independent of whether or not the branch is taken.

Incorrectly used delayed branches can leave the PC undefined. Example 7–6 illustrates an incorrectly-placed delayed branch.

Example 7–6. Incorrectly Placed Delayed Branches

```

B1:BD L1
    NOP
    NOP
B2:B L2    ; This branch is incorrectly placed
    NOP
    NOP
    NOP
    .
    .
    .

```

Sometimes, a branch is necessary for the program flow when fewer than three instructions can be placed after a delayed branch. For faster execution, it is still advantageous to use a delayed branch. This is shown in Example 7–7, with a NOP taking the place of the third unused instruction. The tradeoff is more instruction words for less execution time.

Example 7–7. Delayed Branch Execution

```

*   TITLE DELAYED BRANCH EXECUTION
    .
    .
    .
    .
    LDF*+AR1(5),R2 ; Load contents of memory to R2
    BGED SKIP     ; If loaded number >=0, branch
                    (delayed)
    LDFN R2,R1    ; If loaded number <0, load it to R1
    SUBF 3.0,R1  ; Subtract 3 from R1
    NOP          ; Dummy operation to complete
                    delayed branch
    MPYF 1.5,R1  ; Continue here if loaded number < 0
    .
    .
    .
SKIP LDF R1,R3   ;Continue here if loaded number >=0

```

There are two types of delayed branches: branches without annulling and branches with annulling.

7.2.1 Delayed Branches Without Annulling

Delayed branches without annulling do not empty the pipeline but guarantee that the next three instructions execute before the program counter is modified by the branch. The delayed branches without annulling are *BcondD*, *BRD*, and *DBcondD*.

7.2.2 Delayed Branches With Annulling

Delayed branches with annulling may conditionally annul the next three instructions. The delayed branches with annulling are *BcondAT* and *BcondAF*:

BcondAF

If the condition is true, the *BcondAF* instruction executes the three instructions following the branch and then branches. If the condition is false, the processor does not take the branch and it annuls the effects of the execute phase of the first following instruction and the effects of the read and execute phases of the second and third following instructions.

BcondAT

If the condition is true, the *BcondAT* instruction causes a branch and annuls the effects of the execute phase of the first following instruction and the effects of the read and execute phases of the second and third following instructions. If the condition is false, the instruction causes the execution of the three instructions following the branch and does not cause a branch.

7.3 Calls, Traps, Branches, Jumps, and Returns

Calls and traps can execute a subroutine or function while providing a return to the calling routine.

The `CALL`, `CALLcond`, and `TRAPcond` instructions store the value of the PC on the stack before changing the PC's contents. The `RETScond` or `RETIcond` (standard or delayed) instructions use the value on the stack to return execution from traps and calls.

`CALL` is a four-cycle instruction, while `CALLcond` and `TRAPcond` are five-cycle instructions. 'C4x delayed instructions `LAJ`, `LAJcond`, and `LATcond` provide equivalent functionality, respectively, but in a single cycle.

- **CALL** places the next PC value on the stack and places the *src* (source) operand into the PC. The *src* is a 24-bit PC-relative or register value. Figure 7–1 shows `CALL` response timing.
- **CALLcond** is similar to the `CALL` instruction (above) except for two differences:
 - It executes only if a specific condition is true (the 20 conditions — including unconditional — are listed in Section 14.2 on page 14-12).
 - The *src* is either a 24-bit PC-relative displacement or in register addressing mode.
- **TRAPcond** executes only if a specific condition is true (same conditions as for the `CALLcond` instruction). When it executes, a four-step sequence occurs:
 - 1) The values of the GIE and CF status register bits are saved into the PGIE and PCF status register bits.
 - 2) Interrupts are disabled (GIE = 0) and the cache is frozen (CF bit = 0).
 - 3) The next PC value is stored on the stack.
 - 4) The specified vector is retrieved from the trap vector table and is loaded into the PC. The vector address corresponds to a trap number in the instruction.

Using `RETIcond` or `RETIcondD` to return re-enables interrupts if the status register's GIE bit was set previously and recovers the previous CF bit.

- **RETScond** returns execution from any of the above three instructions by popping the top of the stack to the PC. For `RETScond` to execute, the specified condition must be true. The conditions are the same for `RETScond` as for the `CALLcond` instruction.

- ❑ **RETI*cond*** returns from traps or calls in the same way that RET*Scond* does with the addition that RETI*cond* also copies the PGIE and PCF bit values into the GIE and CF bits of the status register. The conditions for RETI*cond* are the same as for the CALL*cond* instruction.
- ❑ **RETI*cond*D** returns from traps or calls in the same way that RETI*cond* does with the addition that RETI*cond*D *first executes* the three instructions immediately following RETI*cond*D. The conditions for RETI*cond*D are the same as for the CALL*cond* instruction.
- ❑ Link and jump (**L*A*J**), link and jump conditional (**L*A*J*cond***), and link and trap conditional (**L*A*T*cond***) each provide a return address in extended-precision register R11.
 - After it executes the three instructions that follow it, L*A*J jumps to an address derived by a 24-bit PC-relative addressing mode (see subsection 6.6 for more information).
 - The L*A*J*cond* destination address is either PC-relative (a displacement) or the contents of a specified register. If the condition is true, L*A*J*cond* first executes the three instructions following the L*A*J*cond* before making the jump. If the condition is not true, execution continues immediately after the L*A*J*cond* instruction.
 - After it executes the three instructions that follow it, L*A*T*cond* calls one of the 512 available trap vectors pointed to by the trap vector table pointer (see Section 3.2, on page 3-17, for more information about the TVTP).

Functionally, calls and traps accomplish the same task—a subfunction is called and executed, and control is then returned to the calling function. Traps offer two advantages over calls:

- ❑ Interrupts are automatically disabled when a trap is executed. This allows critical code to execute without risk of being interrupted. Thus, traps are usually terminated with a RETI*cond* or RETI*cond*D instruction to re-enable interrupts if the status register GIE bit was set previously.
- ❑ You can use traps to indirectly call functions. This is particularly beneficial when a kernel of code contains the basic subfunctions to be used by applications. In this case, you can modify the functions in the kernel and relocate them without recompiling each application.

Figure 7-1. CALL Response Timing

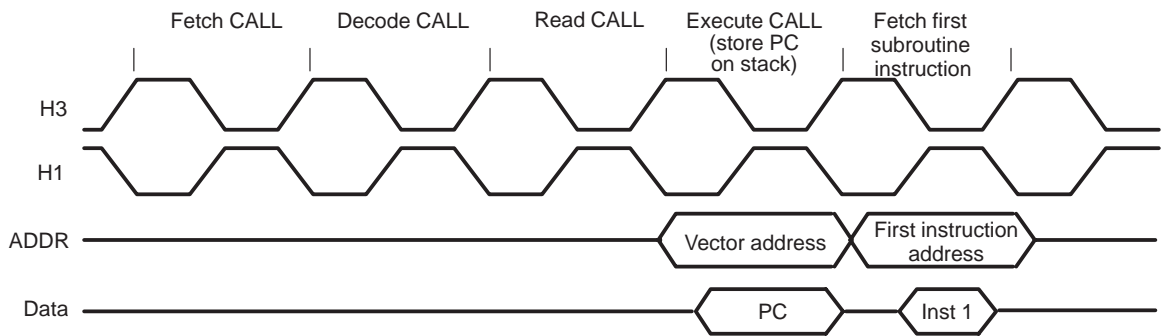

7.4 Interrupts

The 'C4x supports multiple internal and external interrupts, which can be used for a variety of applications. Internal interrupts are generated by the DMA controller, the timers, and the communication ports. The five external interrupt pins include four external maskable interrupt pins ($\overline{\text{IIOF0}}\text{--}\overline{\text{IIOF3}}$) and one non-maskable interrupt ($\overline{\text{NMI}}$) pin. Interrupts can be sent to both the CPU and the DMA controller.

Interrupts on the 'C4x are automatically prioritized. This allows interrupts that occur simultaneously to be serviced in a predefined order.

This section discusses the operation of these interrupts. Additional information regarding internal interrupts can be found in Section 12.6, *Coordinating Communication Ports with the CPU and DMA Processor*, on page 12-17, Section 11.10, *DMA and Interrupts*, on page 11-42, and Chapter 13, *Timers*. See Section 7.6, *DMA Interrupts*, on page 7-26, for more information about interrupts to the DMA controller.

7.4.1 Interrupt Vector Table and Prioritization

The interrupt vector table (IVT) shown in Figure 7-2 contains the interrupt vectors. An interrupt vector is an address of an interrupt service routine that should start executing when an interrupt is received. The IVT table must be placed on a 512-word memory boundary. The table location is determined by the value that is stored in the IVTP register (see Section 3.2, *CPU Expansion Register File*, on page 3-17).

Prioritization means that an interrupt in a higher position in the interrupt vector table (Figure 7-2) is serviced before one in a lower position *when both are received in the same clock cycle or when two previously received interrupts are waiting to be serviced*. It *does not* mean, for example, that $\overline{\text{IIOF3}}$ must wait until service routines for $\overline{\text{IIOF2}}$, $\overline{\text{IIOF1}}$, and $\overline{\text{IIOF0}}$ are completed (when $\text{ST}(\text{GIE}) = 1$).

The priority of interrupts is handled by the CPU according to the interrupt vector table. Priority is set according to position in the table — those with displacements closest to the IVTP base address are higher in priority (i.e., $\overline{\text{NMI}}$ is higher than TINT0 , which is higher than $\overline{\text{IIOF0}}$, etc.). Note that interrupt TINT0 is located at $\text{IVTP} + 2$, while the TINT1 vector is located at $\text{IVTP} + 2\text{Bh}$ after the communication port and DMA coprocessor interrupts.

Figure 7–2. Interrupt-Vector Table (IVT)

IVTP+			IVTP+		
000h	Reserved	Note 1	01Dh	ICFULL4	Note 5
001h	NMI	Note 2	01Eh	ICRDY4	
002h	TINT0	Note 3	01Fh	OCRDY4	
003h	IIOF0	Note 4	020h	OCEMPTY4	
004h	IIOF1		021h	ICFULL5	
005h	IIOF2		022h	ICRDY5	
006h	IIOF3		023h	OCRDY5	
007h	Unused		024h	OCEMPTY5	Note 6
.			025h	DMA INT0	
00Ch			026h	DMA INT1	
00Dh	ICFULL0	Note 5	027h	DMA INT2	
00Eh	ICRDY0		028h	DMA INT3	
00Fh	OCRDY0		029h	DMA INT4	
010h	OCEMPTY0		02Ah	DMA INT5	
011h	ICFULL1		02Bh	TINT1	Note 3
012h	ICRDY1		02Ch	Unused	Note 3
013h	OCRDY1		.		
014h	OCEMPTY1		.		
015h	ICFULL2	.			
016h	ICRDY2	.			
017h	OCRDY2	.			
018h	OCEMPTY2	.			
019h	ICFULL3	.			
01Ah	ICRDY3	.			
01Bh	OCRDY3	.			
01Ch	OCEMPTY3		03Eh	Unused	
			03Fh	Reserved	

- Notes:**
- 1) Reserved for the reset vector. See Table 7–4.
 - 2) NMI (the nonmaskable interrupt) is discussed in subsection 7.4.5.
 - 3) Timer interrupts TINT0 and TINT1 are enabled by the IIE register (subsection 3.1.9, page 3-11) and monitored at the IIF register (subsection 3.1.10, page 3-13).
 - 4) External pins IIOF0—IIOF3 are programmed in the IIF register (subsection 3.1.10, page 3-13).
 - 5) The communication port I/O buffers full/empty/ready interrupts are enabled by the IIE register and are also described in Figure 12–4, on page 12-8, (OUTPUT LEVEL and INPUT LEVEL bits).
 - 6) Interrupts from the DMA are enabled at the IIE register and DMA channel control register at bits TCC and AUX TCC (see Figure 11–2, on page 11-8, for bit descriptions).
 - 7) In the 'C44, the interrupts for communication ports 0 and 3 are active. If you enable them with the IE bit, the ISR will be executed.

7.4.2 CPU Interrupt Control Bits

Three CPU registers contain bits used to control CPU interrupt operation:

- ❑ **The CPU status register (ST).** The CPU global interrupt enable bit (GIE), located in the ST, controls all maskable CPU interrupts. When this bit is set to 1, CPU interrupts are globally enabled. When this bit is cleared to 0, all CPU interrupts are disabled (except NMI, the nonmaskable interrupt). Refer to subsection 3.1.7, *Status Register (ST)*, on page 3-5.
- ❑ **Internal interrupt enable register (IIE).** The IIE is used to enable CPU internally-generated interrupts (from timers, communication ports, and DMA channels). See subsection 3.1.9, *CPU Internal Interrupt Enable Register (IIE)*, on page 3-11, for more information.
- ❑ **IIOF flag register (IIF).** The IIF contains interrupt flag bits and bits to determine the function of the external-interrupt pins ($\overline{\text{IIOF0}} - \overline{\text{IIOF3}}$).

The IIF Register

When an external interrupt or most of the internal interrupts are received, a corresponding bit in the IIF register is set to 1. The only internally generated interrupts that do not have a flag bit in the IIF register are the communication port interrupts.

When the CPU services an interrupt that has an interrupt flag bit in the IIF register, or when the DMA controller latches this type of interrupt into a DMA internal signal, this flag bit is cleared by the internal interrupt acknowledge signal. However, for level-triggered interrupts, if $\overline{\text{IIOFn}}$ is still low when the interrupt acknowledge signal occurs, the interrupt flag bit is cleared for only one cycle and then set to 1 again. For this reason, it is theoretically possible that, depending on when the IIF register is read, the interrupt flag bit may be zero, even though $\overline{\text{IIOFn}}$ is low. After reset, zero is written to the interrupt flag register, thereby clearing all pending interrupts.

The IIF register bits can be read or written under software control. This provides access to the $\overline{\text{IIOFx}}$ pins, which can be treated as general-purpose I/O or as interrupt pins. For example, if at the IIF register, $\text{FUNCx} = 0$ (I/O pin) and $\text{TYPEx} = 1$ (output pin), then by writing into the FLAGx bit, you can also write to the external pin $\overline{\text{IIOFx}}$. If $\text{FUNCx} = 1$ (interrupt pin), writing a 1 to the IIF register FLAGx bit has the same effect as an incoming interrupt received on the corresponding pin. In this way, all interrupts can be triggered and/or cleared through software. Since the interrupt bits also can be read, the interrupt pins can be polled in software when an interrupt-driven interface is not required.

Internal interrupts operate in a similar manner. In the IIF register, the bit corresponding to an internal interrupt (e.g., TINT0, TINT1) can be read and written to through software. Writing a 1 sets the interrupt latch, and writing a 0 clears it. All internal interrupts are one H1/H3 cycle in length. If any previous bit values of the IIF register need to be preserved, a modification to IIF should be performed with logic operations (AND, OR, etc), directly to the IIF register.

Figure 7–3. IIF Register Modification

<p>correct LDI @MASK, R0 AND R0, IIF</p>	<p>incorrect LDI IIF, R1 AND @MASK, R1 LDI R1, IIF</p>
---	--

7.4.3 Interrupt Processing

For an interrupt to occur, at least two conditions must be met:

- All interrupts must be enabled globally by setting the GIE bit to 0 in the CPU status register (ST).
- The interrupt must be enabled by setting the corresponding bit in the IIE register.

The CPU interrupt processing cycle (shown in Figure 7–4) involves several events. The corresponding interrupt flag in the IIF register is cleared, the values of the GIE and CF status register bits are preserved, the cache is frozen (CF = 1), interrupts are globally disabled (GIE = 0), and the CPU completes all fetched instructions. Then, the interrupt vector is fetched and loaded into the PC, and the CPU continues execution of the first instruction in the interrupt service routine (ISR). When you use *RETIcond* or *RETIcondD* to return from the interrupt service routine, the previous GIE and CF bit values are recovered.

If you wish to make the interrupt service routine interruptible, you can set the GIE bit to 1 after entering the ISR. In addition, you can enable the cache. Be aware that because the PGIE and PCF status register bits are one deep, they preserve only the previous GIE and CF bits.

Note:

The GIE, and CF are preserved and loaded with new values after the completion of the last instruction that was fetched before the interrupt was flushed. This guarantees later restoration of correct flag values.

Figure 7–4. CPU Interrupt Processing

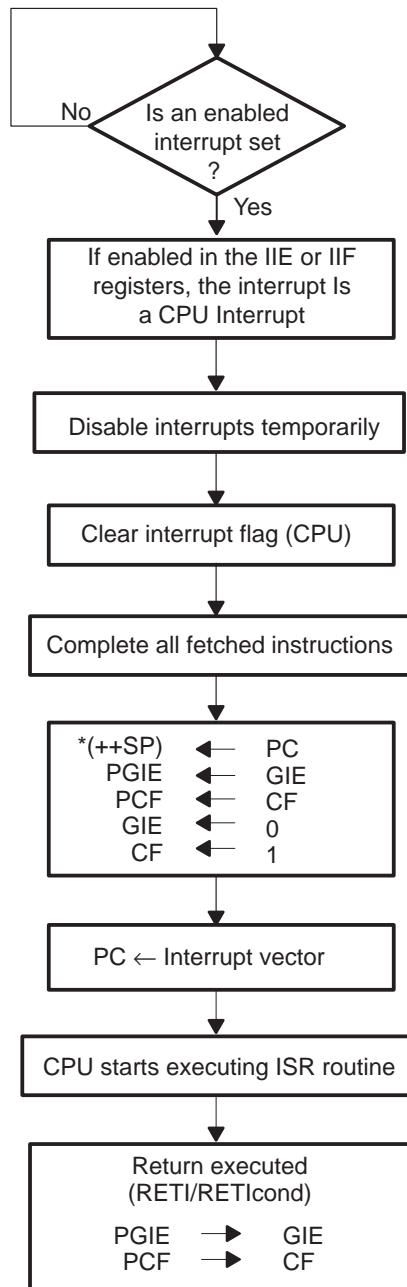

CPU interrupts (including NMI) are only acknowledged (responded to by the CPU) on instruction fetch boundaries. If instruction fetches are halted because of pipeline conflicts or when an RPTS loop is executing, CPU interrupts are not acknowledged until the next instruction fetch.

The interrupt acknowledge (IACK) instruction can be used to signal externally that an interrupt has been serviced. If external memory is specified in the operand, IACK drives the $\overline{\text{IACK}}$ pin and performs a dummy read. The read is performed from the address specified by the IACK instruction operand. IACK is typically placed in the early portion of an interrupt service routine. However, depending on your application, it may be better suited at the end of the interrupt service routine or at another location. You are not required to use the IACK instruction in interrupt service routines.

Note the following situations:

- Interrupts are disabled during a RPTS and during a delayed branch (until the 3 instructions following a delayed branch are completed). Interrupts are held until after the branch.
- When an interrupt occurs, instructions currently in the decode and read phases continue regular execution. This is not the case for an instruction in the fetch phase:
 - If the interrupt occurs in the first cycle of the fetch of an instruction, the fetched instruction is discarded (not executed), and the address of that instruction is pushed to the top of the system stack.
 - If the interrupt occurs after the first cycle of the fetch (in the case of a multicycle fetch due to wait states), that instruction is executed, and the address of the next instruction to be fetched is pushed to the top of the system stack.
 - If no program fetch is occurring, then no new fetch is performed.

7.4.4 CPU Interrupt Latency

CPU interrupt latency, defined as the time from the acknowledgement of the interrupt to the execution of the first instruction of the interrupt service routine (ISR), is at least 8 cycles. This is explained in Table 7–2 where the interrupt is treated as an instruction, assuming that all the instructions are single-cycle instructions.

Table 7–2. Interrupt Latency

Cycle	Description	Fetch	Decode	Read	Execute
1	Recognize interrupt in single-cycle fetched (prog a+1) instruction.	prog a+1	prog a	prog a–1	prog a–2
2	Temporarily disable interrupt until GIE is cleared. Clear the corresponding IIF flag (if applicable).	—	interrupt	prog a	prog a–1
3	Read the interrupt vector table.	—	—	interrupt	prog a
4	Store return address to stack; save the GIE bit into PGIE and CF into PCF. Then, clear the GIE bit and set the CF bit to 1.	—	—	—	interrupt
5	Pipeline begins to fill with ISR instruction.	isr1	—	—	—
6		isr2	isr1	—	—
7		isr3	isr2	isr1	—
8	Execute first instruction of interrupt service routine.	isr4	isr3	isr2	isr1

7.4.5 External Interrupts

The five external interrupt pins include four external maskable interrupt pins ($\overline{\text{IIOF0}}$ – $\overline{\text{IIOF3}}$) and one nonmaskable interrupt ($\overline{\text{NMI}}$) pin.

The four external maskable interrupts ($\overline{\text{IIOF0}}$ – $\overline{\text{IIOF3}}$) are enabled at the IIF register (subsection 3.1.10 page 3-13) and are synchronized internally. They are sampled on the falling edge of H1 and passed through a series of H1/H3 delays internally. Once synchronized, the interrupt input will set the corresponding interrupt flag register (IIF) bit if the interrupt is active. The list below shows the external interrupts and their corresponding interrupt vectors:

$\overline{\text{IIOF}}$ Pin and Interrupt	Interrupt Vector Location
$\overline{\text{IIOF0}}$	IVTP + 003h
$\overline{\text{IIOF1}}$	IVTP + 004h
$\overline{\text{IIOF2}}$	IVTP + 005h
$\overline{\text{IIOF3}}$	IVTP + 006h

These interrupts are prioritized by the selection of one over the other if both come on the same clock cycle ($\overline{\text{IIOF0}}$ the highest, $\overline{\text{IIOF1}}$ next, etc.). When an interrupt is taken, the status register ST(GIE) bit is reset to 0, disabling any other incoming interrupt (except NMI). This prevents any other interrupt ($\overline{\text{IIOF0}}$ – $\overline{\text{IIOF3}}$) from assuming program control until the ST(GIE) bit is set back to 1. In addition, the ST(GIE) bit is saved into ST(PGIE) and the ST(CF) bit into ST(PCF). On a return from an interrupt routine, the RETI and RETI*cond* instructions place the value that is in the ST(PGIE) bit into the ST(GIE) bit and ST(PCF) bit into the ST(CF) bit, returning them to their previous values.

External interrupts can be either *edge- or level-triggered*, depending on how the TYPE fields are set in the IIF register (see subsection 3.1.10, *IIOF Flag Register (IIF)*, on page 3-13, for more information about the IIF).

For an edge-triggered interrupt to be detected by the 'C4x, the external pin must transition from 1 to 0. And then, it needs to be held low for at least one H1/H3 cycle (but it could be held low longer).

For a level-triggered interrupt to be detected by the 'C4x, the external pin needs to be held low for between one and two cycles ($1 \leq \text{low-pulse width} \leq 2$). If the interrupt is held low for more than two cycles, more than one interrupt might be recognized. There is no need to provide an edge in this case.

Note:

Level-triggered interrupts are unlatched. The 'C4x will only detect them if the low-level is present during a fetch-to-decode pipeline transition. This means that during a pipeline halt, the level-triggered interrupts might be missed even if they are held low between one and two cycles. This is not the case for an edge-triggered interrupt because they are latched (they will get recognized regardless if the pipeline is halted).

NMI

The nonmaskable interrupt, NMI (an incoming low on pin AJ5, signal $\overline{\text{NMI}}$), is not masked by the ST(GIE) bit. Even though the NMI is nonmaskable, its processing is temporarily postponed during delayed branches and multicycle CPU operations. NMI is a negative-going, edge-triggered, latched interrupt.

Take special care when using an NMI as a second level interrupt. When the 'C4x services an interrupt, interrupts are disabled except for the NMI. This creates a problem because the ST register may end up with the wrong value if the NMI is executed before the first level ISR that preserves the ST register's value.

The TMS320C44 and the TMS320C40 (revision 5.0 and greater) has a software-configurable feature that allows the forcing ready of the internal peripher-

al bus when the $\overline{\text{NMI}}$ signal is asserted. This NMI bus-grant feature is enabled when bits 18 and 19 in the status register (ST) are set to 10_2 . When enabled, a peripheral bus-grant signal is generated on the falling edge of $\overline{\text{NMI}}$. If $\overline{\text{NMI}}$ is asserted and this feature is not enabled, the CPU stalls on an access to the peripheral bus if the bus is not ready. A stall condition occurs when writing to a full output FIFO or reading an empty input FIFO. This feature is useful in correcting communication-port errors when used in conjunction with the communication-port software-reset feature.

7.5 Traps

A trap is the equivalent of a software-triggered interrupt. In the 'C4x, traps and interrupts are treated identically, except in the way in which they are initialized.

7.5.1 Initialization of Traps and Interrupts

Traps and interrupts are initialized differently in the 'C4x.

Traps are always triggered by a software mechanism, by the *TRAPcond* (conditional trap) and *LATcond* (link and trap conditionally delayed) instructions.

Interrupts are always triggered by hardware events (for example, by external interrupts, DMA interrupts, or communication channel interrupts).

These GIE bit in the ST register and the mask bits in the IIE do not apply to traps.

7.5.2 Operation of Traps

Figure 7–5 shows the general flow of traps (and also of interrupts).

Figure 7–5. Flow of Traps

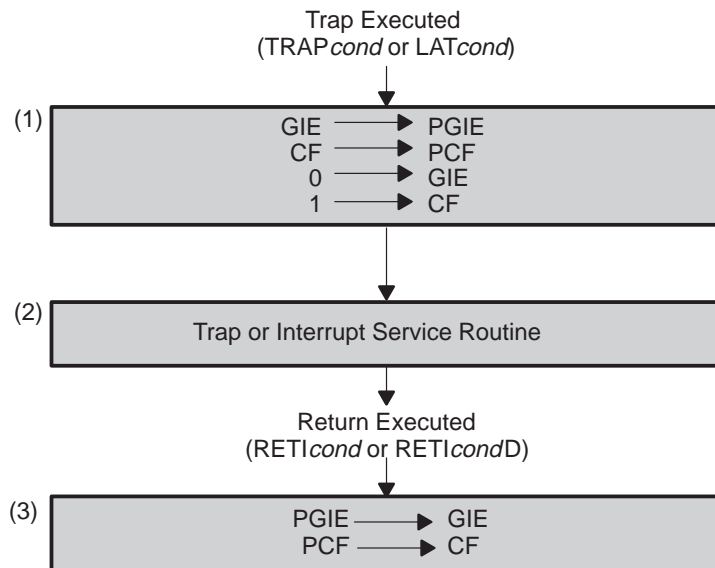

The **RETIcond** and **RETIcondD** instructions manipulate the status flags as shown in block (3) in Figure 7–5. *RETIcond*/*RETIcondD* provides a return/delayed return from a trap or interrupt.

In general, you should not directly modify the PGIE or PCF status register bits except when putting the status register on a stack for recursive interrupts or traps.

The 'C4x supports 512 different traps. When a `TRAPcond n` or `LATcond n` instruction is executed, the 'C4x jumps to the address stored in the memory location pointed to by `TVTP + n`, where `TVTP` is the Trap Vector Table Pointer register. The 32-bit `TVTP` register is essentially the base address for the trap-vector table (TVT) in memory. This table, shown in Figure 7–6, contains the addresses of the trap service routines that are executed by the CPU.

Figure 7–6. Trap Vector Table (TVT)

TVTP + 000h	TRAP0
TVTP + 001h	TRAP1 to
TVTP + 1FEh	TRAP510
TVTP + 1FFh	TRAP511

As with the interrupt vector table (IVT), the trap vector table (TVT) must begin on a 512-word memory boundary. The TVT pointer register (`TVTP`) points to the beginning of the TVT. See Section 3.2, *CPU Expansion Register File*, on page 3-17, for more information about the `TVTP`.

The `TRAP` or `LATcond` instructions can be used to generate a trap and manipulate the status flags as shown in block (1) in Figure 7–5. `LATcond` (link and trap conditionally) provides a single-cycle trap that is very useful for error detection and correction.

Note:

Because `LATcond` is a delayed instruction, the three instructions following `LATcond` should not modify the GIE or CF status register bits (this could result in storing incorrect values of these two bits).

7.5.3 Overlapping the Trap and Interrupt Vector Tables

The interrupt and trap vector tables can share the same 512-byte space in memory. In this configuration, you can place trap vectors where there are no interrupt vectors. For example, since interrupt vector `02Ch` is unused, you could place a trap vector at `IVTP+02Ch` (which is also `TVTP+02Ch` if the tables overlap) and then call that trap by specifying `02Ch` in the `TRAP` instruction.

7.6 DMA Interrupts

Interrupts can trigger DMA read and write operations. This is called DMA synchronization. The DMA interrupt processing cycle is similar to that of the CPU. After the pertinent interrupt flag is cleared, the DMA coprocessor proceeds according to the status of the SYNC bits in the DMA coprocessor global control register.

If the interrupt in the DMA Interrupt Enable (DIE) register is enabled, the interrupt controller automatically latches the interrupt and saves it for future DMA use. In the case of the flag interrupts (timer, external interrupt), the IIF flags are cleared when the interrupt controller latches the interrupt, not when the DMA responds to it. Even if the DMA has not been started, the interrupt latch occurs, except when the start bits in the DMA control register have the reset value 00₂ in START (AUX START) bits. DMA reset clears the interrupt internal latch.

7.6.1 DMA Interrupt Control Bits

Two registers contain bits used to control DMA interrupt operation:

- ❑ DMA interrupt enable register (DIE). All DMA interrupts are controlled by bits in the DIE and by the SYNC bits of the DMA channel control registers (described in Figure 11–2). The DMA interrupts are not dependent upon ST(GIE) and are local to the DMA.
- ❑ The DMA channel control register. Each DMA coprocessor channel uses a channel control register to determine its mode of operation. This register is shown in Figure 11–2.

The DIE is broken into six subfields that determine which interrupts can be used to control the synchronization for each of the six DMA channels. For example, the bits in these each of these fields allow you to select whether a DMA channel is synchronized to a communication port, a timer, or an external interrupt pin.

See subsection 3.1.8, *DMA Coprocessor Interrupt Enable Register (DIE)*, on page 3-8, for a description of the DIE.

7.6.2 DMA Interrupt Processing

Figure 7–7 shows the general flow of interrupt processing by the DMA coprocessor.

Figure 7–7. DMA Interrupt Processing

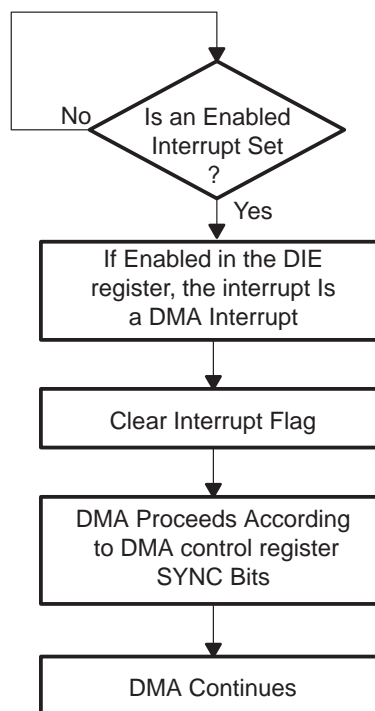

For more information about DMA interrupts, see Section 11.10, *DMA and Interrupts*.

7.6.3 CPU/DMA Interrupt Interaction

The 'C4x DMA coprocessor is not affected by the processing of CPU interrupts, even when the DMA is using interrupts for synchronization of transfers. In addition, the DMA is not affected, even when pipeline fetches are halted.

The 'C4x allows the CPU and DMA controller to respond to and process interrupts in parallel. Figure 7–8 shows the sequence of events in interrupt processing for both the CPU and the DMA controller; for the exact sequence of events, see Table 7–2.

It is therefore possible to interrupt the CPU and DMA coprocessors simultaneously with the same or different interrupts and, in effect, synchronize their activities. However, because the DMA coprocessor and CPU share the same set of interrupt flags, in some instances the DMA coprocessor can clear an interrupt flag before the CPU can respond to it. For example, if CPU interrupts are disabled or if instruction fetches have been halted, the DMA can latch the interrupt and thus clear the associated interrupt flag. If the interrupt is enabled in the DIE register, the CPU will never be able to “steal” a DMA interrupt, because the DMA responds to an interrupt as fast as or faster than the CPU.

Figure 7–8. Parallel CPU and DMA Interrupt Processing

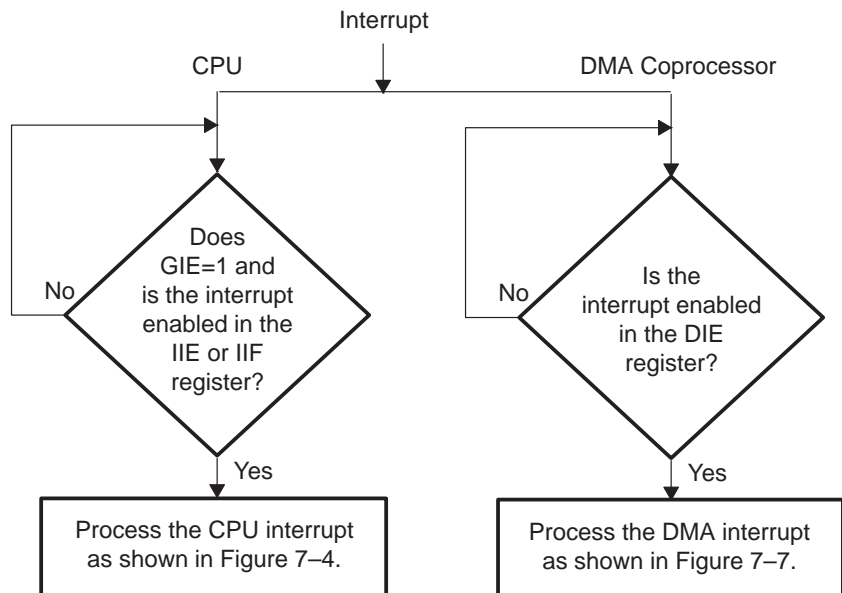

7.7 Reset

The 'C4x supports a nonmaskable external reset signal ($\overline{\text{RESET}}$), which is used to perform system reset. This section discusses the reset operation.

After powerup, the state of the 'C4x processor is undefined. You can use the $\overline{\text{RESET}}$ signal to put the processor in a known state. This signal must be asserted low for 10 or more H1 clock cycles to guarantee a system reset (See Chapter 1, *Processor Initialization*, in the *TMS320C4x General-Purpose Applications User's Guide* for the recommended reset circuit). H1 is an output clock signal generated by the 'C4x.

Reset affects several aspects of 'C4x operation:

- Some device pins
- Some device registers
- Program execution

7.7.1 Reset's Effects on Pin States

Reset affects the other pins on the device in either a synchronous or an asynchronous manner. The synchronous reset is gated by the 'C4x's internal clocks. The asynchronous reset directly affects the pins and is faster than the synchronous reset. Reset timing details are included in the 'C4x data sheets.

Table 7–3 shows the state of the 'C4x's pins during $\overline{\text{RESET}} = 0$ and after $\overline{\text{RESET}}$ goes back to 1. Each pin is described according to whether the pin is reset synchronously or asynchronously.

Table 7–3. Pin States At System Reset

(a) Clock (4 pins)

Signal	Pins	I/O [§]	Type [†]	Description
H1	1	O	S	Begins clocking when $\overline{\text{RESET}}$ makes a 1-to-0 transition
H3	1	O	S	Begins clocking when $\overline{\text{RESET}}$ makes a 1-to-0 transition
X1	1	O	–	No effect
X2/CLKIN	1	I	–	No effect

[†] A = Asynchronous, S = Synchronous

[‡] Recommended decoupling capacitors are one multiple 0.1 μF and 4.7 μF around the device. Number depends on specific board noise conditions.

[§] I=Input, O=Output, Z=High-impedance state.

Table 7–3. Pin States After System Reset (Continued)

(b) Communication Port 0 Interface (12 pins)

Signal	Pins	I/O§	Type†	Description
C0D(7–0)	8	I/O	S	Set to undefined value
$\overline{\text{CACK0}}$	1	I/O	A	Set high-impedance when reset goes low and then set to one when reset goes high
$\overline{\text{CRDY0}}$	1	I/O	A	Set to high-impedance
$\overline{\text{CREQ0}}$	1	I/O	A	Set to high-impedance
$\overline{\text{CSTRB0}}$	1	I/O	A	Set high-impedance when reset goes low and then set to one when reset goes high

(c) Communication Port 1 Interface (12 pins)

Signal	Pins	I/O§	Type†	Description
C1D(7–0)	8	I/O	S	Set to undefined value
$\overline{\text{CACK1}}$	1	I/O	A	Set high-impedance when reset goes low and then set to one when reset goes high
$\overline{\text{CRDY1}}$	1	I/O	A	Set to high-impedance
$\overline{\text{CREQ1}}$	1	I/O	A	Set to high-impedance
$\overline{\text{CSTRB1}}$	1	I/O	A	Set high-impedance when reset goes low and then set to one when reset goes high

(d) Communication Port 2 Interface (12 pins)

Signal	Pins	I/O§	Type†	Description
C2D(7–0)	8	I/O	S	Set to undefined value
$\overline{\text{CACK2}}$	1	I/O	A	Set high-impedance when reset goes low and then set to one when reset goes high
$\overline{\text{CRDY2}}$	1	I/O	A	Set to high-impedance
$\overline{\text{CREQ2}}$	1	I/O	A	Set to high-impedance
$\overline{\text{CSTRB2}}$	1	I/O	A	Set high-impedance when reset goes low and then set to one when reset goes high

† A = Asynchronous, S = Synchronous

‡ Recommended decoupling capacitors are one multiple 0.1 μF and 4.7 μF around the device. Number depends on specific board noise conditions.

§ I=Input, O=Output, Z=High-impedance state.

Table 7–3. Pin States After System Reset (Continued)

(e) Communication Port 3 Interface (12 pins)

Signal	Pins	I/O§	Type†	Description
C3D(7–0)	8	I/O	S	Set to high-impedance
$\overline{\text{CACK3}}$	1	I/O	A	Set to high-impedance
$\overline{\text{CRDY3}}$	1	I/O	A	Set high-impedance when reset goes low and then set to one when reset goes high
$\overline{\text{CREQ3}}$	1	I/O	A	Set high-impedance when reset goes low and then set to one when reset goes high
$\overline{\text{CSTRB3}}$	1	I/O	A	Set to high-impedance

(f) Communication Port 4 Interface (12 pins)

Signal	Pins	I/O§	Type†	Description
C4D(7–0)	8	I/O	S	Set to high-impedance
$\overline{\text{CACK4}}$	1	I/O	A	Set to high-impedance
$\overline{\text{CRDY4}}$	1	I/O	A	Set high-impedance when reset goes low and then set to one when reset goes high
$\overline{\text{CREQ4}}$	1	I/O	A	Set high-impedance when reset goes low and then set to one when reset goes high
$\overline{\text{CSTRB4}}$	1	I/O	A	Set to high-impedance

(g) Communication Port 5 Interface (12 pins)

Signal	Pins	I/O§	Type†	Description
C5D(7–0)	8	I/O	S	Set to high-impedance
$\overline{\text{CACK5}}$	1	I/O	A	Set to high-impedance
$\overline{\text{CRDY5}}$	1	I/O	A	Set high-impedance when reset goes low and then set to one when reset goes high
$\overline{\text{CREQ5}}$	1	I/O	A	Set high-impedance when reset goes low and then set to one when reset goes high
$\overline{\text{CSTRB5}}$	1	I/O	A	Set to high-impedance

† A = Asynchronous, S = Synchronous

‡ Recommended decoupling capacitors are one multiple 0.1 μF and 4.7 μF around the device. Number depends on specific board noise conditions.

§ I=Input, O=Output, Z=High-impedance state.

Table 7–3. Pin States After System Reset (Continued)

(h) Emulation (7 pins)

Signal	Pins	I/O§	Type†	Description
EMU0	1	I/O	–	Undefined
EMU1	1	I/O	–	Undefined
TCK	1	I	–	No effect
TDI	1	I	–	No effect
TDO	1	O	–	No effect
TMS	1	I	–	No effect
TRST	1	I	–	No effect

(i) Global Bus External Interface (80 pins)

Signal	Pins	I/O§	Type†	Description
A(30–0)	31	O/Z	S	Set to high-impedance
\overline{AE}	1	I	–	No effect
$\overline{CE}0$	1	I	–	No effect
$\overline{CE}1$	1	I	–	No effect
D(31–0)	32	I/O/Z	S	Set to high-impedance
\overline{DE}	1	I	–	No effect
\overline{LOCK}	1	O	S	Set to one
PAGE0	1	O/Z	S	Set to zero
PAGE1	1	O/Z	S	Set to zero
$\overline{RDY}0$	1	I	–	No effect
$\overline{RDY}1$	1	I	–	No effect
$R/\overline{W}0$	1	O/Z	S	Set to one
$R/\overline{W}1$	1	O/Z	S	Set to one
STAT(3–0)	4	O	S	Set to all ones
STRB0	1	O/Z	S	Set to one
$\overline{STRB}1$	1	O/Z	S	Set to one

† A = Asynchronous, S = Synchronous

‡ Recommended decoupling capacitors are multiple 0.1 μ F and 4.7 μ F around the device. Number depends on specific board noise conditions.

§ I=Input, O=Output, Z=High-impedance state.

Table 7–3. Pin States After System Reset (Continued)

(j) Local Bus External Interface (80 pins)

Signal	Pins	I/O [§]	Type [†]	Description
LA(30–0)	31	O/Z	S	Placed in high-impedance state
$\overline{\text{LAE}}$	1	I	–	Reset has no effect
$\overline{\text{LCE0}}$	1	I	–	Reset has no effect
$\overline{\text{LCE1}}$	1	I	–	Reset has no effect
$\overline{\text{LDE}}$	1	I	–	Reset has no effect
$\overline{\text{LLOCK}}$	1	O	S	Set to one
LPAGE0	1	O/Z	S	Set to zero
LPAGE1	1	O/Z	S	Set to zero
$\overline{\text{LRDY0}}$	1	I	–	Reset has no effect
$\overline{\text{LRDY1}}$	1	I	–	Reset has no effect
LR $\overline{\text{W}}$ 1	1	O/Z	S	Set to one
LSTAT(3–0)	4	O	S	Set to all ones
$\overline{\text{LSTRB0}}$	1	O/Z	S	Set to one
$\overline{\text{LSTRB1}}$	1	O/Z	S	Set to one

(k) Interrupts, I/O Flags, Reset, Timer (12 pins)

Signal	Pins	I/O [§]	Type [†]	Description
IACK	1	I	S	Set to one
$\overline{\text{IIOF}}(0–3)$	4	I/O	A	Set to high-impedance
NMI	1	I	–	No effect
RESET	1	I	–	RESET input pin
RESETLOC(1,0)	2	I	–	No effect
ROMEN	1	I	–	No effect
LD(31–0)	32	I/O/Z	S	Set to high-impedance
TCLK0	1	I/O	A	Set to high-impedance
TCLK1	1	I/O	A	Set to high-impedance

[†] A = Asynchronous, S = Synchronous[‡] Recommended decoupling capacitors are one multiple 0.1 μF and 4.7 μF around the device. Number depends on specific board noise conditions.[§] I=Input, O=Output, Z=High-impedance state.

Table 7–3. Pin States After System Reset (Continued)

(I) Power (70 pins)

Signal	Pins	I/O§	Type†	Description
SUBS	1	I	–	Substrate pin (tie to ground). Set to high-impedance.
V _{SSL}	4	I	–	Ground pins. Set to high-impedance.
CV _{SS}	15	I	–	Ground pins. Set to high-impedance.
DV _{SS}	15	I	–	Ground pins. Set to high-impedance.
IV _{SS}	6	I	–	Ground pins. Set to high-impedance.
DV _{DD}	13	I	–	+5V _{DC} supply pins. Set to high-impedance.‡
GADV _{DD}	3	I	–	+5V _{DC} supply pins. Set to high-impedance.‡
GDDV _{DD}	3	I	–	+5V _{DC} supply pins. Set to high-impedance.‡
LADV _{DD}	3	I	–	+5V _{DC} supply pins. Set high-impedance.‡
LDDV _{DD}	3	I	–	+5V _{DC} supply pins. Set to high-impedance.‡
V _{DDL}	4	I	–	+5V _{DC} supply pins. Set to high-impedance.‡

† A = Asynchronous, S = Synchronous

‡ Recommended decoupling capacitors are one multiple 0.1 μ F and 4.7 μ F around the device. Number depends on specific board noise conditions.

§ I=Input, O=Output, Z=High-impedance state.

7.7.2 Reset Vector Location

When $\overline{\text{RESET}}$ is released, the 'C4x begins executing the application program. The initial address of the program is stored in the reset vector. The 'C4x permits selection of any one of four reset vector locations. Selection of the reset vector location that is used is determined by the levels on the RESETLOC1 and RESETLOC0 pins at reset. Table 7–4 shows the possible configurations of these pins.

Table 7–4. $\overline{\text{RESET}}$ Vector Locations

Value at RESETLOCx Pin		Get Reset Vector From Hex Memory Address	Comment
RESETLOC1	RESETLOC0		
0	0	00000 0000	Local Bus
0	1	07FFF FFFF†	Local Bus
1	0	08000 0000†	Global Bus
1	1	0FFFF FFFF†	Global Bus

† This corresponds to the 32-bit address that the processor accesses. However, in the 'C44 only the 24-LSBs of the reset address will be driven on pins A0–A23 or pins LA0–LA23. The corresponding LSTRBx pins will also be activated.

7.7.3 Additional Reset Operations

After system reset (after RESET goes back from 0 to 1), the following additional operations are performed:

- Timer registers are set.
 - The timer global control register is set to 0, except that bit DATIN is set to the value on pin TCLK.
 - The timer counter and timer period registers set to zeros.
- Control registers for communication ports 0–2 (subsection 12.3.1 on page 12-8) are set to zeros (output operation), and control registers for communication ports 3–5 are set to 04h (input operation).
- External memory interface control registers (Section 9.3 on page 9-6) are set to 3E39 FFF0h. (7 wait states)
- DMA channel control register, DMA transfer counter, and DMA auxiliary transfer counter (subsection 11.3.1 on page 11-7) are set to zeros.

- ❑ The following CPU registers are loaded with zeros (each described in Chapter 3):
 - IIE (CPU internal interrupt enable register)
 - IIF (interrupt flag register)
 - DIE (DMA internal enable register)
 - IVTP (interrupt-vector table pointer)
 - TVTP (trap-vector table pointer)
- ❑ The CPU status register (ST) is set to 0400h, which puts the on-chip cache in *cache freeze* mode.
- ❑ The reset vector is read from its location and loaded into the PC.
- ❑ If ROMEN=1 (Internal ROM enabled), the RESETLOC(1,0) pins are low, and the $\overline{\text{IOF0}}$ pin is high, the 'C4x will start execution of the bootloader code. Otherwise, the 'C4x will start execution of the routine which is pointed to by the reset vector corresponding to the RESETLOC(1,0) pins.

Multiple 'C4xs driven by the same system clock can be reset and synchronized. See *Reset Signal Generation* in the *TMS320C4x General-Purpose User's Guide* for information about resetting multiple 'C4xs.

Pipeline Operation

Two characteristics of the 'C4x that contribute to its high performance are pipelining and concurrent I/O and CPU operation.

Four functional units control 'C4x pipeline operation: fetch, decode, read, and execute. Pipelining is the overlapping or parallel operations of the fetch, decode, read, and execute levels of a basic instruction.

The DMA coprocessor decreases pipeline interference and enhances the CPU's computational throughput by performing input/output operations.

Topic	Page
8.1 Pipeline Structure	8-2
8.2 Pipeline Conflicts	8-4
8.3 Memory Accesses for Maximum Performance	8-17
8.4 Clocking of Memory Accesses	8-19

8.1 Pipeline Structure

The four major units of the 'C4x pipeline structure and their functions are as follows:

Fetch Unit (F)	Fetches the instruction words from memory and updates the program counter (PC).
Decode Unit (D)	Decodes the instruction word and performs address generation. Also, controls modification of the ARn registers in the indirect addressing mode, and of the stack pointer when PUSH to/POP from the stack occurs.
Read Unit (R)	If required, reads the operands from memory.
Execute Unit (E)	If required, reads the operands from the register file, performs the necessary operation, and writes results to the register file. If required, results of previous operations are written to memory.

A basic instruction has four levels: fetch, decode, read, and execute. Figure 8–1 illustrates these four levels of the pipeline structure. The levels are indexed according to instruction and execution cycle. In the figure, perfect overlap in the pipeline, where all four units operate in parallel, occurs at cycle (m). Levels about to be executed are at $m + 1$, and those just executed are at $m - 1$. The 'C4x pipeline controller supports a high-speed processing rate of one execution per cycle. It also manages pipeline conflicts so that they are transparent to the user. You do not need to take any special precautions to guarantee correct operation.

Figure 8–1. Pipeline Structure

CYCLE	Fetch	Decode	Read	Execute	
m-3	W	—	—	—	
m-2	X	W	—	—	
m-1	Y	X	W	—	
m	Z	Y	X	W	← Perfect overlap
m+1	—	Z	Y	X	
m+2	—	—	Z	Y	
m+3	—	—	—	Z	

- Notes:**
- 1) W, X, Y, and Z represent instructions.
 - 2) F, D, R, E = fetch, decode, read, and execute, respectively.

Priorities from highest to lowest have been assigned to each of the functional units of the pipeline and to the DMA controller as follows:

- DMA (if configured as highest priority)
- Execute
- Read
- Decode
- Fetch
- DMA (if configured as lowest priority).

When the processing of an instruction is ready to pass to the next higher pipeline level and that level is not ready to accept a new input, a pipeline conflict occurs. In this case, the lower priority unit waits until the higher priority unit completes its currently executing function.

8.2 Pipeline Conflicts

Pipeline conflicts in the 'C4x can be grouped into the following three main categories:

- Branch Conflicts** Involve most of those instructions or operations that read and/or modify the PC.
- Register Conflicts** Involve delays that can occur when reading from or writing to registers that are used for address generation, such as: AR0–AR7, IR0, IR1, BK, DP and SP.
- Memory Conflicts** Occur when the internal units of the 'C4x compete for memory resources.

Each of these three types is discussed in the following subsections. Examples are included. Note in these examples, when data is refetched or an operation is repeated, the symbol representing the stage of the pipeline is appended with a number. For example, if a fetch is performed again, the instruction mnemonic is repeated. The symbol $\overline{\text{RDY}}$ is used to indicate that a unit is not ready and the symbol RDY is used to indicate that a unit is ready.

8.2.1 Branch Conflicts

Branch conflicts involve most of the instructions or operations that read and/or modify the PC.

8.2.1.1 Standard Branches

Pipeline conflicts occur with standard (nondelayed) branches, i.e., BR, *Bcond*, *DBcond*, CALL, IDLE, RPTB, RPTS, *RET1cond*, *RETScond*, interrupts, and reset, because their execution is all the pipeline can handle. Other information fetched into the pipeline is discarded or refetched, or the pipeline becomes inactive; this is referred to as flushing the pipeline. Flushing the pipeline is necessary in these cases to prevent partial execution of succeeding instructions. The branches discussed here are loads; TRAP *cond* and CALL*cond* are treated as conditional stores and are shown in Example 8–13.

Example 8–1 shows the code and pipeline operation for a standard branch. Note that one dummy fetch is performed (MPYF instruction), and then after the branch address is available, a new fetch (OR instruction) is performed. This dummy fetch introduces the MPYF instruction into the cache.

Example 8–1. Standard Branch

```

BR THREE      ; Unconditional branch
MPYF         ; Not executed
ADD          ; Not executed
SUBF        ; Not executed
AND          ; Not executed
.
.
.
THREE OR     ; Fetched after BR is taken
STI
.
.
    
```

PIPELINE OPERATION

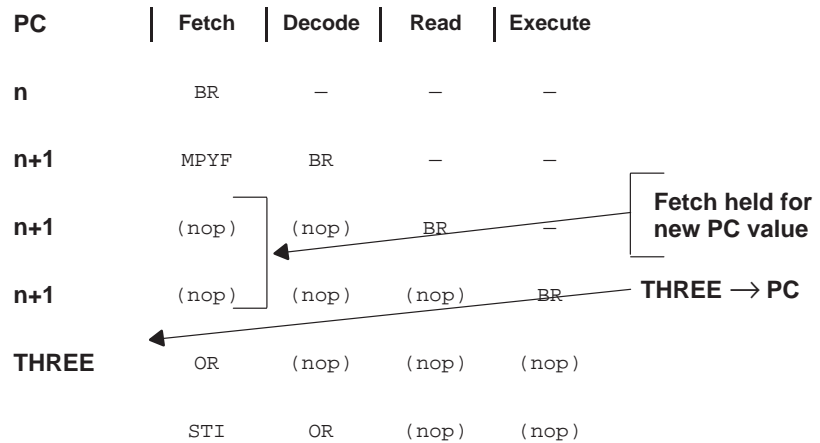

Note:

Both RPTS and RPTB flush the pipeline, allowing the RS, RE, and RC registers to be loaded at the proper time. If these registers are loaded without the use of RPTS or RPTB, no flushing of the pipeline occurs. Thus, RS, RE, and RC can be used as general-purpose 32-bit registers without pipeline conflicts. When RPTB is nested because of nested interrupts, it may be necessary to load and store these registers directly while using the repeat modes. Since up to four instructions can be fetched before the repeat mode is entered, loads should be followed by a branch to flush the pipeline. If the RC is changing when an instruction is loading it, the direct load takes priority over the modification made by the repeat mode logic.

8.2.1.2 Delayed Branches Without Annul Option

Delayed branches are implemented to assure that the next three instructions are fetched and executed. The delayed branches without annul option include BRD, BcondD, and DBcondD. Example 8–2 shows the code and pipeline operation for a delayed branch.

Example 8–2. Delayed Branch Without Annul Option

```

BRD THREE           ; Unconditional delayed branch
  MPYF              ; Executed
  ADD               ; Executed
  SUBF              ; Executed
  AND               ; Not executed
.
.
.
  THREE MPYF        ; Fetched after SUBF is fetched
.
.
.
    
```

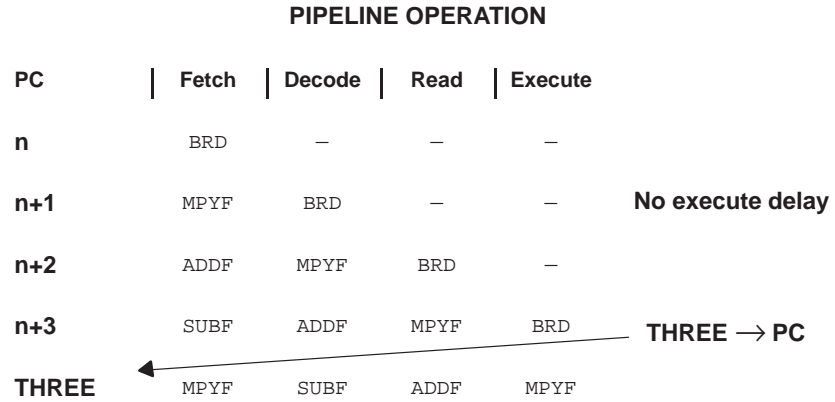

8.2.1.3 Delayed Branches With Annul Option

The 'C4x supports delayed branches with an annulling option: *BcondAT* (branch conditional, annul if true) and *BcondAF* (branch conditional, annul if false). The true or false status of the condition controls whether or not a branch is performed (as in a delayed branch). The annulling operation cancels the effect of the execute phase of the first instruction and of the read and execute phases of the second and third instructions following the *BcondAT* or *BcondAF*.

- If the condition is true, *BcondAT* performs a branch, and the annulling operation takes place. Otherwise, the branch is not taken and the annulling operation does not take place.
- If the condition is false, *BcondAF* does not perform a branch, and the annulling operation takes place. Otherwise, the branch is taken and the annulling operation does not take place.

See subsection 7.2.2 for more information about delayed branches with annulling. Example 8–3 uses both *BcondAT* and *BcondAF*.

Example 8–3. Using *BcondAF* and *BcondAT* Instructions

```

        LDI        *AR1,R0
        BNAT      bottom    ; If negative, branch and
        ADDI      *++AR2,R3 ; annul the execute phase
        MPYF      ; of ADDI, MPYF, and NOT.
        NOT      ; Otherwise, don't annul and
top:    SUBF      ; continue with SUBF.
        .
        .
        SUBI      1,R0
        BNNAF    top        ; If not negative, branch and
        ADDI      *++AR2,R3 ; do not annul the execute
        MPYF      ; phase of ADDI, MPYF, and
        NOT      ; NOT. Otherwise, annul ADDI,
bottom: XOR      ; MPYF, and NOT, and continue
        .        ; with XOR.

```

At the start of Example 8–3, if the result of the load is *negative* (a *true* condition), the *BcondAT* instruction causes a branch and also annuls the execute phase of the three instructions that follow it. As a result, the execute phase of the *ADDI* instruction does not occur, and register R3 is not updated by addition. However, AR2 is incremented, and data at the corresponding address is read because these operations are in the decode and read phases of the pipeline, respectively, and thus cannot be annulled.

Two types of operations can be annulled:

- All writes to the register file that occur in the execute phase (ADDs, LDs, etc., but not LDA, LDPK, etc.)
- All stores to memory

8.2.2 Register Conflicts

A register conflict occurs if you read from or write to a register used for addressing purposes (AR0–AR7, IR0, IR1, BK, DP, and SP) when the register is not ready to be used. For example, if an instruction writes to one of these registers, the decode unit cannot use that same register until the write is complete (which occurs in the execute stage).

In Example 8–4, an auxiliary register is loaded, and the same auxiliary register is used on the next instruction. Since the decode stage needs the result of the write to the auxiliary register, the decode of this second instruction is delayed two cycles. Every time the decode is delayed, a refetch of the program word is performed; i.e., ADDF is fetched three times. Because these are actual refetches, they can cause not only conflicts with the DMA controller, but also cache hits and misses. If the AR register used in the MPYF instruction were different from the one used in the LDI instruction, no delay would occur.

Example 8–4. Write to an AR Followed by an AR for Address Generation

```

LDI    7,AR2    ; 7 → AR2
NEXT  MPYF  *AR2,R0 ; Decode delayed 2 cycles
      ADDF
      FLOAT
    
```

PIPELINE OPERATION

PC	Fetch	Decode	Read	Execute	
n	LDI	–	–	–	
n+1	MPYF	LDI	–	–	Decode/address generation held for a new AR value
n+2	ADDF	MPYF	LDI	–	
n+2	ADDF	MPYF	(nop)	LDI 7,AR2	AR2 loaded
n+2	ADDF	MPYF	(nop)	(nop)	
n+3	FLOAT	ADDF	MPYF	(nop)	

Conflicts involving reads are similar to those involving writes. If an instruction must read registers AR0–AR7 or SP, the use of those particular registers by the decode stage for the following instruction is delayed until the read is complete. The registers are read at the start of the execute cycle and therefore require only a one-cycle delay of the following decode. For four registers (IR0, IR1, BK, or DP), no delay is incurred upon a read.

In Example 8–5, two auxiliary registers are added together with the result going to an extended-precision register. The next instruction uses one of the same auxiliary registers as an address register. If the MPYF instruction used an AR register other than AR0 or AR2, *no delay would occur*.

Example 8–5. A Read of ARs Followed by ARs for Address Generation

```

ADDI  AR0,AR2,R1 ; AR0 + AR2 → R1
NEXT  MPYF  *++AR2,R0 ; Decode delayed 1 cycle
      ADDF
      FLOAT
    
```

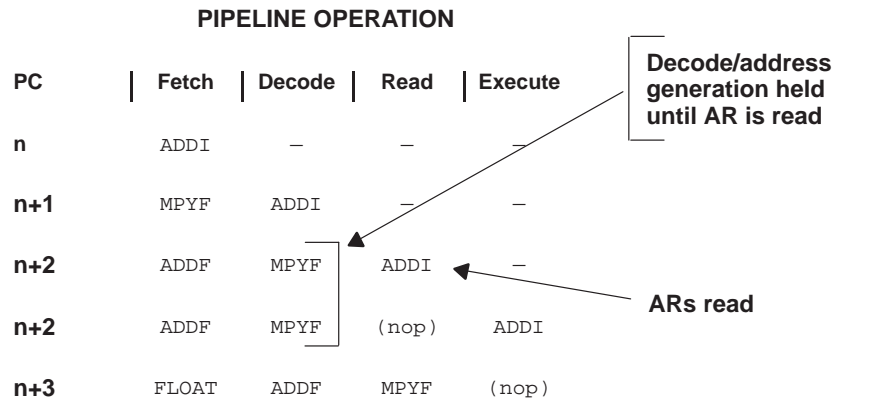

Note:

The DBR (decrement and branch) instruction’s use of auxiliary registers for loop counters is treated the same as if the use were for addressing. Therefore, the operation shown in the two previous examples can also occur for this instruction.

8.2.3 Memory Conflicts

Memory conflicts can occur when the memory bandwidth of a physical memory space is exceeded. RAM blocks 0 and 1 and the ROM block can support only two accesses per cycle. The external interface can support only one access per cycle. Some conditions under which memory conflicts can be avoided are discussed in Section 8.3, on page 8-17.

Memory pipeline conflicts consist of the following four types:

Program Wait	A program fetch is prevented from beginning.
Program Fetch Incomplete	A program fetch has begun but is not yet complete.
Execute Only	An instruction sequence requires three CPU data accesses in a single cycle.
Hold Everything	A global or local bus operation must complete before another one can proceed.

These four types of memory conflicts are illustrated in examples and discussed in the paragraphs that follow.

8.2.3.1 Program Wait

Two conditions can delay an instruction fetch:

- Too many accesses to the same memory at the start of a CPU data access can occur in two cases:
 - Two CPU data accesses are made to an internal RAM or ROM block, and a program fetch from the same block is necessary.
 - One of the external ports is starting a CPU data access, and a program fetch from the same port is necessary.
- A multicycle CPU data access or DMA data access over the external bus is needed.

Example 8–6 illustrates a program wait until a CPU data access completes. In this case, *AR0 and *AR1 are both pointing to data in RAM block 0, and the MPYF instruction will be fetched from RAM block 0. This results in the conflict shown. Since no more than two accesses can be made to RAM block 0 in a single cycle, the program fetch cannot begin and must wait until the CPU data accesses are complete.

Example 8–6. Program Wait Until CPU Data Access Completes

```

ADDF3 *AR0, *AR1, R0
FIX
MPYF
ADDF3
NEGB

```

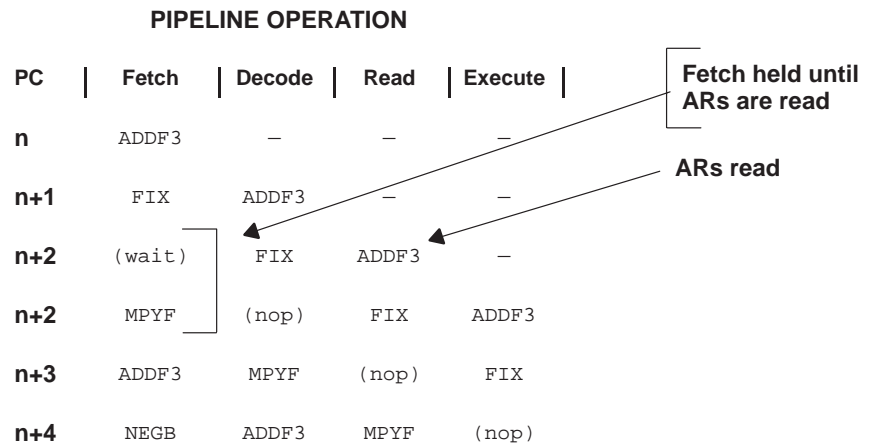

Example 8–7 shows a program wait due to a multicycle data-data access or a multicycle DMA access. The ADDF, MPYF, and SUBF are fetched from some portion in memory other than the external port the DMA requires. The DMA begins a multicycle access. The program fetch corresponding to the CALL is made to the same external port that the DMA is using.

Even if the DMA is configured as the lowest priority, **a multicycle access cannot be aborted**. The program fetch must therefore wait until the DMA access completes.

Example 8–7. Program Wait Due to Multicycle Access

PIPELINE OPERATION				
PC	Fetch	Decode	Read	Execute
n	ADDF	–	–	–
n+1	MPYF	ADDF	–	–
n+2	SUBF	MPYF	ADDF	–
n+3	(wait)	SUBF	MPYF	ADDF
n+3	CALL	(nop)	SUBF	MPYF
n+4	–	CALL	(nop)	SUBF

2-cycle DMA access

8.2.3.2 Program Fetch Incomplete

A program fetch incomplete occurs when an instruction fetch takes more than one cycle to complete because of wait states. In Example 8–8, the MPYF and ADDF are fetched from memory that supports single-cycle accesses. The SUBF is fetched from memory requiring one wait state. One example that demonstrates this conflict is a fetch across a bank boundary on the external port.

Example 8–8. Multicycle Program Memory Fetches

PIPELINE OPERATION				
PC	Fetch	Decode	Read	Execute
n	MPYF	–	–	–
n+1	ADDF	MPYF	–	–
n+2 $\overline{\text{RDY}}$	SUBF	ADDF	MPYF	–
n+2 RDY	SUBF	(nop)	ADDF	MPYF
n+3	ADDI	SUBF	(nop)	ADDF

1 wait state required

8.2.3.3 Execute Only

The Execute Only type of memory pipeline conflict occurs when a sequence of instructions requires three CPU data accesses in a single cycle. There are two cases in which this occurs:

- ❑ An instruction performs a store and is followed by an instruction that performs two memory reads.
- ❑ An instruction performs two stores and is followed by an instruction that performs at least one memory read.

The first case is shown in Example 8–9. Since this sequence requires three data memory accesses and only two are available, only the execute phase of the pipeline is allowed to proceed. The dual reads required by the LDF || LDF are delayed one cycle. Note that in this case a refetch of the next instruction can occur, which could cause an additional access to memory.

Example 8–9. Single Store Followed by Two Reads

STFR0,*AR1	;	R0 → *AR1
LDF*AR2,R1	;	*AR2 → R1 in parallel with
LDF*AR3,R2	;	*AR3 → R2

PIPELINE OPERATION

PC	Fetch	Decode	Read	Execute	
n	STF	–	–	–	
n+1	LDF LDF	STF	–	–	
n+2	W	LDF LDF	STF	–	Write must complete before the 2 reads can complete.
n+3	X	W	LDF LDF	STF	
n+4	X	W	LDF LDF	(nop)	
n+4	Y	X	W	LDF LDF	

Example 8–10 shows a parallel store followed by a single load or read. Since two parallel stores are required, the next CPU data memory read must wait one cycle before beginning. One program memory refetch may occur.

Example 8–10. Parallel Store Followed by Single Read

```

    STF    R0,*AR0 ; R0 → *AR0 in parallel with
  || STF    R2,*AR1 ; R2 → *AR1
    ADDF   @SUM,R1 ; R1 + @SUM → R1
    IACK
    ASH
  
```

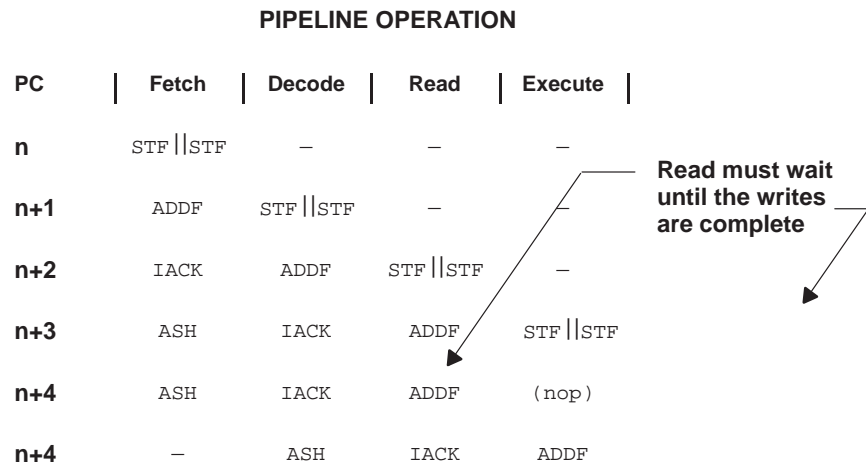

8.2.3.4 Hold Everything

Three types of conditions cause Hold Everything memory pipeline conflicts:

- ❑ A CPU data load or store cannot be performed because an external port is busy.
- ❑ An external load takes more than one cycle.
- ❑ The execution of conditional calls and traps, which take one more cycle than conditional branches.

The first type of Hold Everything conflict occurs when one of the external ports is busy because of an access that has started but is not complete. In Example 8–11, the first store is a two-cycle store. The CPU writes the data to an external port. The port control then takes two cycles to complete the data-data write. The LDF is a read over the same external port. Since the store is not complete, the CPU continues to attempt processing the LDF until the port is available.

Example 8–11. Busy External Port

STF	R0 ,@DMA1
LDF	@DMA2 ,R0

PIPELINE OPERATION				
PC	Fetch	Decode	Read	Execute
n	STF	–	–	–
n+1	LDF	STF	–	–
n+2	W	LDF	STF	–
n+2	W	LDF	(nop)	STF
n+2	W	LDF	(nop)	(nop)
n+3	X	W	LDF	(nop)
n+4	Y	X	W	LDF

↑ 2-cycle external bus write access ↓

The second type of Hold Everything conflict involves multicycle data reads. In this case, the read has begun and continues until completed. In Example 8–12, the LDF is performed from an external memory that requires several cycles to access.

Example 8–12. Multicycle Data Reads

LDF @DMA, R0

PIPELINE OPERATION					
PC	Fetch	Decode	Read	Execute	
n	LDF	–	–	–	
n+1	I	LDF	–	–	
n+2	J	I	LDF	–	
n+3	K (dummy)	I	LDF	–	
n+3	K ₂	J	I	LDF	

2-cycle external bus read access

The final type of Hold Everything conflict deals with conditional calls (*CALLcond*) and traps (*TRAPcond*), which are different from other branch instructions. Whereas other branch instructions are conditional loads, the conditional calls and traps are conditional stores, which take one more cycle to complete than conditional branches (see Example 8–13). The added cycle pushes the return address after the call condition is evaluated.

Example 8–13. Conditional Calls and Traps

PIPELINE OPERATION					
PC	Fetch	Decode	Read	Execute	
n	<i>CALLcond</i>	–	–	–	
n+1	I	<i>CALLcond</i>	–	–	
n+1	(nop)	(nop)	<i>CALLcond</i>	–	
n+1	(nop)	(nop)	(nop)	<i>CALLcond</i>	
n+1	(nop)	(nop)	(nop)	<i>CALLcond</i>	
n+2/CALLaddr	I	(nop)	(nop)	(nop)	

PC store cycle

8.3 Memory Accesses for Maximum Performance

If program fetches and data accesses are performed in such a manner that the resources being used cannot provide the necessary bandwidth, the pipeline is stalled until the accesses are complete. Certain configurations of program fetch and data accesses yield conditions under which the 'C4x can achieve maximum throughput.

Table 8–1 shows how many accesses can be performed from the different memory spaces when it is necessary to do a program fetch and a single data access, and still achieve maximum performance (one cycle). Four cases achieve one-cycle maximization.

Table 8–1. One Program Fetch and One Data Access for Maximum Performance

Case No.	Global Bus Accesses	Accesses From Dual-Access Internal Memory	Local Bus Or Peripheral Accesses
1	1	1	—
2	1	—	1
3	—	2 from any combination of internal memory	—
4	—	1	1

Table 8–2 shows how many accesses can be performed from the different memory spaces when it is necessary to do a program fetch and two data accesses, still achieving maximum performance (one cycle). Six cases achieve this maximization.

Table 8–2. One Program Fetch and Two Data Accesses for Maximum Performance

Case No.	Global Bus Accesses	Accesses From Dual-Access Internal Memory	Local Or Peripheral Bus Accesses
1	1	2 from any combination of internal memory	—
2†	1 program	1 data	1 data
3†	1 data	1 data	1 program
4	1 data	1 program, 1 data	1 DMA
5	—	2 from same internal memory block and 1 from a different internal memory block	—
6	—	3 from different internal memory blocks	1 DMA
7	—	2 from any combination of internal memory	1
8	1 program	2 data	1 DMA
9	1 DMA	2 data	1 program

† For Cases 2 and 3, see Three-Operand Instruction Memory Reads on page 8-20.

8.4 Clocking of Memory Accesses

This section discusses the role of internal clock phases (H1 and H3) in the way the 'C4x handles multiple memory accesses. Whereas the previous section discussed the interaction between sequences of instructions, this section discusses the flow of data on an individual instruction basis.

Each major clock period of 40 ns is composed of two minor clock periods of 20 ns, labeled H3 and H1 (these times assume a 50-MHz 'C40). The active clock period for H3 and H1 is the time when that signal is high.

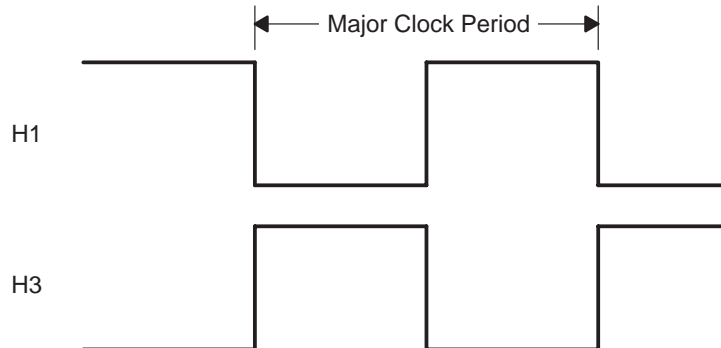

The precise operation of memory reads and writes can be defined according to these minor clock periods. The types of memory operations that can occur are program fetches, data loads and stores, and DMA accesses. Internal DMA data accesses always start during the H3 cycle.

8.4.1 Program Fetches

Internal program fetches are always performed during H3 unless a single data store must occur at the same time because of another instruction in the pipeline. In that case, the program fetch occurs during H1 and the data store occurs during H3.

External program fetches always start at the beginning of H3 with the address being presented on the external bus. At the end of H1, the fetches are completed with the latching of the instruction word.

8.4.2 Data Loads and Stores

Four types of instructions perform loads, memory reads, and stores: two-operand instructions, three-operand instructions, multiplier/ALU operation with store instructions, and parallel multiply and add instructions. See Chapter 6 for detailed information on addressing modes.

As discussed in Chapter 9, the number of bus cycles for external memory accesses differs in some cases from the number of CPU execution cycles. For external reads, the number of bus cycles and CPU execution cycles is identical. For external writes, there are always at least two bus cycles, but unless there is a port access conflict, there is only one CPU execution cycle. In the following examples, any difference in the number of bus cycles and CPU cycles is noted.

8.4.2.1 Two-Operand Instruction Memory Accesses

Figure 8–2. Two-Operand Instruction Word

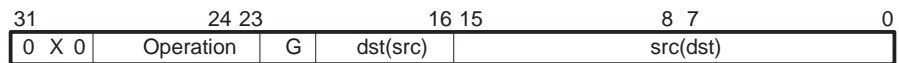

Two-operand instructions include all those instructions with bits 31–29 being 000_2 or 010_2 (see Figure 8–2). In the case of a data read, bits 15–0 represent the *src* operand. Internal data reads are always performed during H1. External data reads always start at the beginning of H3 with the address presented on the external bus, and they complete with the latching of the data word at the end of H1.

In the case of a data store, bits 15–0 represent the *dst* operand. Internal data stores are performed during H3. External data stores always start at the beginning of H3 with the address and data presented on the external bus.

8.4.2.2 Three-Operand Instruction Memory Reads

Figure 8–3. Three-Operand Instruction Word

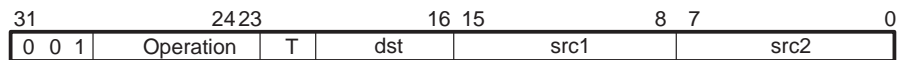

Three-operand instructions include all instructions with bits 31–29 being 001_2 (see Figure 8–3). The source operands, *src1* and *src2*, come from either registers or memory. When one or more of the source operands are from memory, these instructions are always memory reads.

If only one of the source operands is from memory (either *src1* or *src2*) and is located in internal memory, the data is read during H1. If the single memory

source operand is in external memory, the read starts at the beginning of H3, with the address presented on the external bus, and completes with the latching of the data word at the end of H1.

If both source operands are to be fetched from memory, then memory reads can occur in several ways:

- If both operands are located in internal memory, the *src1* read is performed during H3 and the *src2* read during H1, thus completing two memory reads in a single cycle.
- If *src1* is in internal memory and *src2* is in external memory, the *src2* access begins at the start of H3 and latches at the end of H1. At the same time, the *src1* access to internal memory is performed during H3. Again, two memory reads are completed in a single cycle.
- If *src1* is in external memory and *src2* is in internal memory, two cycles are necessary to complete the two reads. In the first cycle, the internal *src2* access is performed. The *src1* is also performed, but not latched until the next H3.
- If *src1* and *src2* are both from external memory, two cycles are required to complete the two reads. In the first cycle, the *src1* access is performed and loaded on the next H3; in the second cycle, the *src2* access is performed and loaded on that cycle's H1.

8.4.2.3 Operations with Parallel Stores

Figure 8–4. Multiply or CPU Operation With a Parallel Store

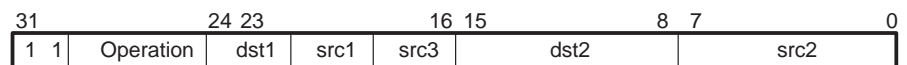

The next class of instructions includes all instructions that have a store in parallel with another instruction. Bits 31 and 30 for these instructions are equal to 11₂.

For operations that perform a multiply or ALU operation in parallel with a store, the instruction word format is shown in Figure 8–4. If the store operation to *dst2* is external or internal, it is performed during H3. Two bus cycles are required for external stores, but only one CPU cycle is necessary to complete the write.

If the memory read operation is external, it starts at the beginning of H3 and latches at the end of H1. If the memory read operation is internal, it is performed during H1. Note that memory reads are performed by the CPU during the read (R) phase of the pipeline, and stores are performed during the execute (E) phase.

The instruction word format for instructions that have parallel stores to memory is shown in Figure 8–5. If both destination operands, *dst1* and *dst2*, are located in internal memory, *dst1* is stored during H3 and *dst2* during H1, thus completing two memory stores in a single cycle.

Figure 8–5. Two Parallel Stores

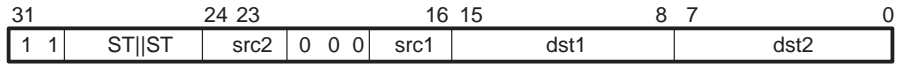

If *dst1* is in external memory and *dst2* is in internal memory, the *dst1* store begins at the start of H3. The *dst2* store to internal memory is performed during H1. Two bus cycles are required for the external store, but only one CPU cycle is necessary to complete the write. Again, two memory stores are completed in a single cycle.

If *dst1* is in internal memory and *dst2* is in external memory, an additional bus cycle is necessary to complete the *dst2* store. Only one CPU cycle is necessary to complete the write, but the port access requires three bus cycles. In the first cycle, the internal *dst1* store is performed during H3, and *dst2* is written to the port during H1. During the next cycle, the *dst2* store is performed on the external bus, beginning in H3, and executes as normal through the following cycle.

If *dst1* and *dst2* are both written to external memory, a single CPU cycle is still all that is necessary to complete the stores. In this case, four bus cycles are required.

- 1) In the first cycle, both *dst1* and *dst2* are written to the port, and the external bus access for *dst1* begins.
- 2) The store for *dst1* is completed on the second cycle.
- 3) The store for *dst2* begins on the third external bus cycle.
- 4) Finally, the store for *dst2* is completed on the fourth external bus cycle.

8.4.2.4 Parallel Multiplies and Adds

Memory addressing for parallel multiplies and adds is similar to that for three-operand instructions. The parallel multiplies and adds include all instructions with bits 31–30 equal to 10₂ (see Figure 8–6).

Figure 8–6. Parallel Multiplies and Adds

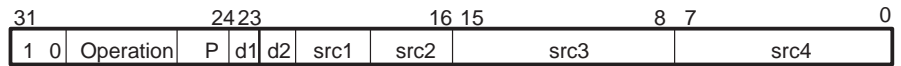

For these operations, *src3* and *src4* are both located in memory. If both operands are located in internal memory, *src3* is performed during H3, and *src4* is performed during H1, thus completing two memory reads in a single cycle.

If *src3* is in internal memory and *src4* is in external memory, the *src4* access begins at the start of H3 and latches at the end of H1. At the same time, the *src3* access to internal memory is performed during H3. Again, two memory reads are completed in a single cycle.

If *src3* is in external memory and *src4* is in internal memory, two cycles are necessary to complete the two reads. In the first cycle, the internal *src4* access is performed. During the H3 of the next cycle, the *src3* access is performed.

If *src3* and *src4* are both from external memory, two cycles are necessary to complete the two reads. In the first cycle, the *src3* access is performed; in the second cycle, the *src4* access is performed.

External Bus Operation

The 'C4x has two identical external bus interfaces. One bus is called the global memory interface and the other bus is called the local memory interface. These buses are designed to allow higher throughput by permitting simultaneous loads and stores to different external memories.

The information in this chapter applies to both the global memory interface and the local memory interface; however, in some sections, only the global memory interface is shown. Examples of memory interfacing are provided in the *TMS320C4x General-Purpose Applications User's Guide*.

Topic	Page
9.1 Overview	9-2
9.2 Memory Interface Signals	9-3
9.3 Memory Interface Control Registers	9-6
9.4 Programmable Wait States	9-14
9.5 Memory Interface Timing	9-16
9.6 Using Enable Signals to Control Signal Groups	9-38
9.7 Interlocked Operations	9-39
9.8 $\overline{\text{IACK}}$ Timing	9-49

9.1 Overview

The 'C4x has two identical parallel external interfaces: the *global memory interface* and the *local memory interface*. Each interface has the following features:

- Separate configurations, each with its own 32-bit data bus and 31-bit address bus (24 pin address bus in the 'C44)
- Single-cycle reads and pipelined writes
- Independent enable signals for data, address, and control lines
- Bus-request and bus-lock signaling for shared memory parallel processing
- User-controlled mapping of addresses to either of two sets of independent strobes for different speed memories
- Look-ahead bus status signals for defining current and requested bus operations for parallel processing arbitration
- Selectable wait states (both software- and hardware-controlled)
- Signals that indicate when memory-page boundaries are crossed.

Note:

The global-memory interface is identical in every way to the local memory interface except that (1) they have different positions in the memory map, and (2) the control signals for the local memory interface are labeled an additional "L" prefix (as described in Figure 9–1 on page 9-3).

Throughout this chapter, no distinction is made between global and local interface signals and between $\overline{\text{STRB0}}$ and $\overline{\text{STRB1}}$, except for clarity.

The signals that indicate when memory-page boundaries are crossed support three main types of memory:

- page-mode and static-column decode DRAMs
- high-speed SRAM banks
- slow speed memory banks and I/O devices

9.2 Memory Interface Signals

As shown in Figure 9–1, the global-memory interface has two sets of control signals, $\overline{\text{STRB0}}$ and $\overline{\text{STRB1}}$. The global-memory port control-registers (Section 9.3 on page 9-6) define which set of registers is active.

Figure 9–1. Global and Local Memory Interface Control Signals

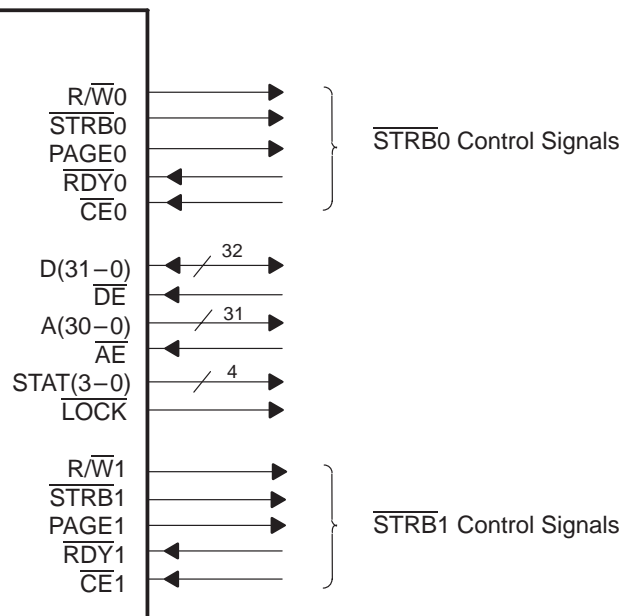

Note: The signals used in this figure are for the global-memory interface. The local-memory interface signals have the same configuration and an additional “L” prefix is added for each signal (for example, $\overline{\text{STRB0}}$ becomes $\text{L}\overline{\text{STRB0}}$, etc.).

Table 9–1. Global Memory Interface Signals

Signal [†]	Type [§]	Description	Value After Reset	Idle Status
\overline{AE} [¶]	I	Address bus enable signal for global-memory interface. When high (set to 1), places address lines A30–0 in the high-impedance state.	N.A. [#]	ignored
$\overline{CE}(0,1)$ [¶]	I	Control signal enable for $R/\overline{W}x$, $\overline{STRB}x$, and $PAGEx$ signals. When high (set to 1), it places the corresponding $R/\overline{W}x$, $\overline{STRB}x$, and $PAGEx$ signals in high-impedance state (x = 0 for $\overline{CE}0$ and x = 1 for $\overline{CE}1$).	N.A.	ignored
\overline{DE} [¶]	I	Data bus enable signal for global memory interface. When high (set to 1), places data lines D31–0 in the high-impedance state. Reads can still occur but writes cannot.	N.A.	ignored
\overline{LOCK} [‡]	O	Lock signal for global bus interface. Indicates whether an interlocked access is underway (0 = access underway; 1 = access not underway). \overline{LOCK} is changed <i>only</i> by the interlocked instructions.	1	1
PAGE(0,1)	O/Z	Memory-page enable signal for $\overline{STRB}(0,1)$ accesses	0	0
$\overline{RDY}(0,1)$	I	Indicates external memory is ready to be accessed	N.A.	ignored
$R/\overline{W}(0,1)$	O/Z	Specifies memory read (active high) or write (active low) mode	1	1
STAT(3–0) [‡]	O	Four lines that define the status or function of the memory port as shown in Table 9–2 (next page).	all 1s	all 1s
$\overline{STRB}(0,1)$	O/Z	Interface access strobe	1	1
A(30–0)	O/Z	Address bus. The address lines are always driven. They keep the address of the last access.	Hi–Z	address of last access
D(31–0)	I/O/Z	Data bus. These signals go to high impedance between write accesses.	Hi–Z	Hi–Z

[†] The numbers in parentheses mean that either a 0 (zero) or a 1 can follow the prefix shown to the left of the parenthesis. A zero indicates $\overline{STRB}0$ control signals (shown in Figure 9–1), and a one indicates $\overline{STRB}1$ control signals.

[‡] STAT(3–0) and \overline{LOCK} **cannot** be controlled by an external control signal.

[§] O=output; I=input; Z=high-impedance state.

[¶] This signal can be used in a shared bus configuration to hold the 'C4x off the shared bus while another 'C4x accesses the shared memory and peripherals.

[#] N.A. means not affected.

^{||} Idle status = no external memory access

Table 9–2 shows how pins STAT3 to STAT0 define the current status of the global-memory port. For bus accesses, these signals provide information about the access that is about to begin. The code for a SIGI instruction read is useful for distinguishing between a SIGI read and a LDII or LDFI read.

The bus idle status code is 1111_2 (given at the bottom of Table 9–2). This simplifies modular shared-bus multiprocessor interfaces because pull-up resistors can be used to signal the idle condition when processor cards are not attached to the shared bus.

Table 9–2. Global Memory Port Status for $\overline{STRB0}$ and $\overline{STRB1}$ Accesses

Value at Pins †				Status
STAT3	STAT2	STAT1	STAT0	
0	0	0	0	$\overline{STRB0}$ access, program read
0	0	0	1	$\overline{STRB0}$ access, data read
0	0	1	0	$\overline{STRB0}$ access, DMA read
0	0	1	1	$\overline{STRB0}$ access, SIGI (instruction) read
0	1	0	0	Reserved
0	1	0	1	$\overline{STRB0}$ access, data write
0	1	1	0	$\overline{STRB0}$ access, DMA write
0	1	1	1	Reserved
1	0	0	0	$\overline{STRB1}$ access, program read
1	0	0	1	$\overline{STRB1}$ access, data read
1	0	1	0	$\overline{STRB1}$ access, DMA read
1	0	1	1	$\overline{STRB1}$ access, SIGI (instruction) read
1	1	0	0	Reserved
1	1	0	1	$\overline{STRB1}$ access, data write
1	1	1	0	$\overline{STRB1}$ access, DMA write
1	1	1	1	Idle

† This table applies to both the global-memory interface and local-memory interface (for local memory interface signals, add an L prefix to form LSTAT3, LSTAT2, etc.).

9.3 Memory-Interface Control Registers

Figure 9–2 shows the memory map for both the global- and local-memory interface-control registers. Figure 9–3 shows the fields in each register. Each register can be programmed to control its respective memory interface by defining the:

- Page size used for the two strobes at each port
- Address ranges over which the strobes are active
- Wait states
- Other operations that control the memory interface

Figure 9–3 lists the fields in these registers.

At reset, the binary values shown above each bit in Figure 9–2 are written to the global memory interface control register. Values in bits 3–0 are the values at these bits' respective pins (\overline{AE} , \overline{DE} , $\overline{CE}1$, and $\overline{CE}0$). Reset has the following effects (for both the local bus and the global bus):

- The PAGESIZE fields for STRB0 (bits 18–14) and STRB1 (bits 23–19) are set to 00111_2 , which corresponds to 256 words.
- The WTCNT fields for STRB0 (bits 10–8) and STRB1 (bits 13–11) are set to 111_2 , which corresponds to seven wait states.
- The ACTIVE field for STRB0 (bits 28–24) is set for all addresses over the global (or local for LSTRB0) memory interface.
- The STRB SWITCH field (bit 29) is set to 1 to insert a cycle between back-to-back reads that switch from $\overline{STRB}0$ to $\overline{STRB}1$ (or $\overline{STRB}1$ to $\overline{STRB}0$).
- The SWW fields for STRB0 (bits 5–4) and STRB1 (bits 7–6) are both set to 11_2 to set the internal ready signal to be the logical AND of the external READY signal (\overline{RDY}) and the ready signal generated by the on-chip wait-state counter (RDY_{wcnt}).

Figure 9–2. Location of the Memory-Interface Control Registers

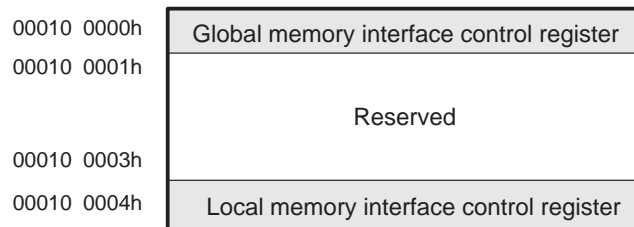
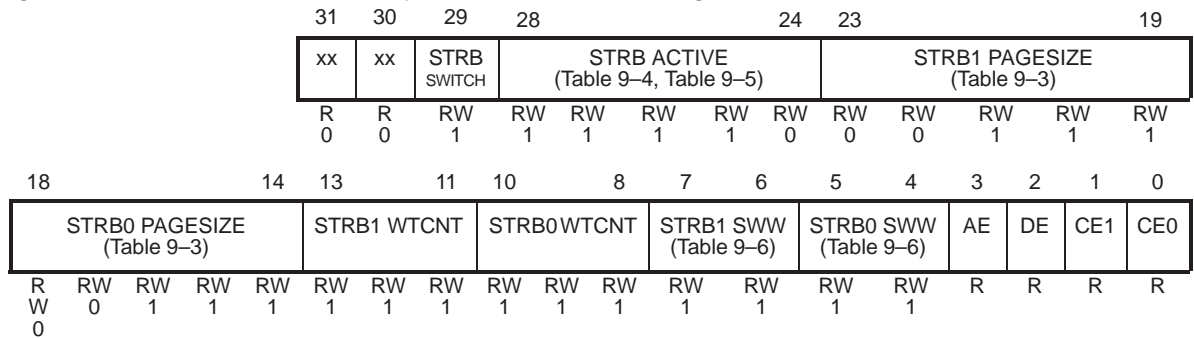

Figure 9–3. Fields in the Memory-Interface Control Registers



- Notes:**
- 1) The register cell figure contains global-memory interface-control register mnemonics. For local-memory interface-control register mnemonics, add an L prefix to each mnemonic in the figure (e.g., LSTRB SWW, LCE0, etc.).
 - 2) The 1s and 0s below each bit are the binary values written to the register at reset. The values at bits 3–0 are defined by the values of their respective external pins (AE, DE, CE1, and CE0).
 - 3) These registers are shown in the overall memory map in Figure 4–1 and Figure 4–3.
 - 4) RW=read/write; R=read.

Note:

Mnemonics used are for the global memory interface control register. For the local-memory interface-control register, add the prefix L to each mnemonic (e.g., LCE0, LCE1, LSTRB1, etc.). The description remains the same for the local-memory interface-control register.

- CE0** Value of external pin $\overline{CE0}$ (after it passes through an internal synchronizer). The value is not latched.
- CE1** Value of external pin $\overline{CE1}$ (after it passes through an internal synchronizer). The value is not latched.
- DE** Value of external pin \overline{DE} (after it passes through an internal synchronizer). The value is not latched.
- AE** Value of external pin \overline{AE} (after it passes through an internal synchronizer). The value is not latched.

STRB0 SWW	Software wait states for $\overline{\text{STRB0}}$ access. In conjunction with STRB0 WTCNT, this field defines the mode of wait-state generation. Actual wait states are explained in Section 9.4 and in Table 9–6.
STRB1 SWW	Software wait states for $\overline{\text{STRB1}}$ access. In conjunction with STRB1 WTCNT, this field defines the mode of wait-state generation. Actual wait states are explained in Section 9.4 and in Table 9–6.
STRB0 WTCNT	Software wait-state count for $\overline{\text{STRB0}}$ accesses. Specifies the number of cycles to use when software wait states are active. Three-bit range is from 000_2 (zero) to 111_2 (seven).
STRB1 WTCNT	Software wait-state count for $\overline{\text{STRB1}}$ accesses. Specifies the number of cycles to use when software wait states are active. Three-bit range is from 000_2 (zero) to 111_2 (seven).
STRB0 PAGESIZE	Page size for $\overline{\text{STRB0}}$ accesses. Specifies the number of MSBs of the address to use to define the bank size for $\overline{\text{STRB0}}$ accesses. See ranges in Table 9–3 and subsection 9.3.2.
STRB1 PAGESIZE	Page size for $\overline{\text{STRB1}}$ accesses. Specifies the number of MSBs of the address to use to define the bank size for $\overline{\text{STRB1}}$ accesses. See ranges in Table 9–3 and subsection 9.3.2.
STRB ACTIVE	Specifies address ranges over which $\overline{\text{STRB0}}^\dagger$ and $\overline{\text{STRB1}}^\dagger$ are active. See ranges in Table 9–4 on for STRB ACTIVE and Table 9–5 for LSTRB ACTIVE.
STRB SWITCH	Inserts a single cycle between back-to-back reads that switch from $\overline{\text{STRB0}}$ to $\overline{\text{STRB1}}$ (or vice versa). When a 1, insert cycle. When a 0, <i>don't</i> insert cycle.
Reserved	Read as zeros.

Table 9–3. Page Size as Defined by $\overline{\text{STRB0/1}}$ PAGESIZE Bits†

STRBx PAGESIZE (Bits 14–18, 19–23)‡	External Address Bus Bits Defining the Current Page	External Address Bus Bits Defining Address on a Page	Page Size (32-Bit Wds)
00000–00110	Reserved	Reserved	Reserved
00111¶	30–8	7–0	2 ⁸ =256
01000	30–9	8–0	2 ⁹ =512
01001	30–10	9–0	2 ¹⁰ =1K
01010	30–11	10–0	2 ¹¹ =2K
01011	30–12	11–0	2 ¹² =4K
01100	30–13	12–0	2 ¹³ =8K
01101	30–14	13–0	2 ¹⁴ =16K
01110	30–15	14–0	2 ¹⁵ =32K
01111	30–16	15–0	2 ¹⁶ =64K
10000	30–17	16–0	2 ¹⁷ =128K
10001	30–18	17–0	2 ¹⁸ =256K
10010	30–19	18–0	2 ¹⁹ =512K
10011	30–20	19–0	2 ²⁰ =1M
10100	30–21	20–0	2 ²¹ =2M
10101	30–22	21–0	2 ²² =4M
10110§	30–23	22–0	2 ²³ =8M
10111	30–24	23–0	2 ²⁴ =16M
11000	30–25	24–0	2 ²⁵ =32M
11001	30–26	25–0	2 ²⁶ =64M
11010	30–27	26–0	2 ²⁷ =128M
11011	30–28	27–0	2 ²⁸ =256M
11100	30–29	28–0	2 ²⁹ =512M
11101	30	29–0	2 ³⁰ =1G
11110	None	30–0	2 ³¹ =2G
11111	Reserved	Reserved	Reserved

† Mnemonics used are for the global-memory interface-control register. For the local-memory interface-control register, add the prefix L to the beginning of each mnemonic (e.g., LSTRB0 PAGESIZE, LSTRB1 PAGESIZE, etc.). The description is the same for the local-memory interface-control register.

‡ The x in STRBx means that the data in the columns are for $\overline{\text{STRB0}}$ or $\overline{\text{STRB1}}$.

§ A STRBx PAGESIZE field of 10110₂ is depicted in Figure 9–5 on page 9-13.

¶ Value at reset.

Table 9–4. Address Ranges Specified by STRB ACTIVE Bits†

STRBx AC-TIVE Field (Bits 24–28)	STRB0 ACTIVE Address Range	Size of STRB0 ACTIVE Address Range	STRB1 ACTIVE Address Range
00000–01110	Reserved	Reserved	Reserved
01111	8000 0000–8000 FFFF	$2^{16}=64\text{K}$	8001 0000–FFFF FFFF
10000	8000 0000–8001 FFFF	$2^{17}=128\text{K}$	8002 0000–FFFF FFFF
10001	8000 0000–8003 FFFF	$2^{18}=256\text{K}$	8004 0000–FFFF FFFF
10010	8000 0000–8007 FFFF	$2^{19}=512\text{K}$	8008 0000–FFFF FFFF
10011	8000 0000–800F FFFF	$2^{20}=1\text{M}$	8010 0000–FFFF FFFF
10100	8000 0000–801F FFFF	$2^{21}=2\text{M}$	8020 0000–FFFF FFFF
10101	8000 0000–803F FFFF	$2^{22}=4\text{M}$	8040 0000–FFFF FFFF
10110	8000 0000–807F FFFF	$2^{23}=8\text{M}$	8080 0000–FFFF FFFF
10111	8000 0000–80FF FFFF	$2^{24}=16\text{M}$	8100 0000–FFFF FFFF
11000	8000 0000–81FF FFFF	$2^{25}=32\text{M}$	8200 0000–FFFF FFFF
11001	8000 0000–83FF FFFF	$2^{26}=64\text{M}$	8400 0000–FFFF FFFF
11010	8000 0000–87FF FFFF	$2^{27}=128\text{M}$	8800 0000–FFFF FFFF
11011	8000 0000–8FFF FFFF	$2^{28}=256\text{M}$	9000 0000–FFFF FFFF
11100	8000 0000–9FFF FFFF	$2^{29}=512\text{M}$	A000 0000–FFFF FFFF
11101	8000 0000–BFFF FFFF	$2^{30}=1\text{G}$	C000 0000–FFFF FFFF
11110‡	8000 0000–FFFF FFFF	$2^{31}=2\text{G}$	None
11111	Reserved	Reserved	Reserved

† Address ranges specified by the LSTRB ACTIVE bits are listed in Table 9–5.

‡ Value at reset.

Table 9–5. Address Ranges Specified by LSTRB ACTIVE Bits†

LSTRBx ACTIVE Field (Bits 24–28)	LSTRB0 ACTIVE Address Range	Size of LSTRB0 ACTIVE Address Range	LSTRB1 ACTIVE Address Range
00000–01110	Reserved	Reserved	Reserved
01111	0000 0000 – 0000 FFFF	$2^{16}=64\text{K}$	0001 0000 – 7FFF FFFF
10000	0000 0000 – 0001 FFFF	$2^{17}=128\text{K}$	0002 0000 – 7FFF FFFF
10001	0000 0000 – 0003 FFFF	$2^{18}=256\text{K}$	0004 0000 – 7FFF FFFF
10010	0000 0000 – 0007 FFFF	$2^{19}=512\text{K}$	0008 0000 – 7FFF FFFF
10011	0000 0000 – 000F FFFF	$2^{20}=1\text{M}$	0010 0000 – 7FFF FFFF
10100	0000 0000 – 001F FFFF	$2^{21}=2\text{M}$	0020 0000 – 7FFF FFFF
10101	0000 0000 – 003F FFFF	$2^{22}=4\text{M}$	0040 0000 – 7FFF FFFF
10110	0000 0000 – 007F FFFF	$2^{23}=8\text{M}$	0080 0000 – 7FFF FFFF
10111	0000 0000 – 00FF FFFF	$2^{24}=16\text{M}$	0100 0000 – 7FFF FFFF
11000	0000 0000 – 01FF FFFF	$2^{25}=32\text{M}$	0200 0000 – 7FFF FFFF
11001	0000 0000 – 03FF FFFF	$2^{26}=64\text{M}$	0400 0000 – 7FFF FFFF
11010	0000 0000 – 07FF FFFF	$2^{27}=128\text{M}$	0800 0000 – 7FFF FFFF
11011	0000 0000 – 0FFF FFFF	$2^{28}=256\text{M}$	1000 0000 – 7FFF FFFF
11100	0000 0000 – 1FFF FFFF	$2^{29}=512\text{M}$	2000 0000 – 7FFF FFFF
11101	0000 0000 – 3FFF FFFF	$2^{30}=1\text{G}$	4000 0000 – 7FFF FFFF
11110‡	0000 0000 – 7FFF FFFF	$2^{31}=2\text{G}$	None
11111	Reserved	Reserved	Reserved

† Address ranges below 0030 0000h are valid only in microprocessor mode (ROMEN=0). Access to reserved, peripheral, and on-chip memory areas does not activate LSTRB signals.

‡ Value at reset.

9.3.1 Mapping Addresses to Strobes

Figure 9–4 demonstrates the relationship between the STRB ACTIVE bits (see Figure 9–3 on page 9-7 for more information) and the address ranges over which the signals, $\overline{\text{STRB0}}$ and $\overline{\text{STRB1}}$, are active. Note that the address ranges of $\overline{\text{STRBx}}$ and $\overline{\text{LSTRBx}}$ also govern the ranges of associated signals— $\overline{\text{RDYx}}$, $\overline{\text{LRDYx}}$, $\text{R}/\overline{\text{Wx}}$, $\text{LR}/\overline{\text{Wx}}$, PAGEx , LPAGEx , etc. (where $x=1$ or 0).

Figure 9–4. Effects of STRB ACTIVE on Global Memory Bus Memory Map

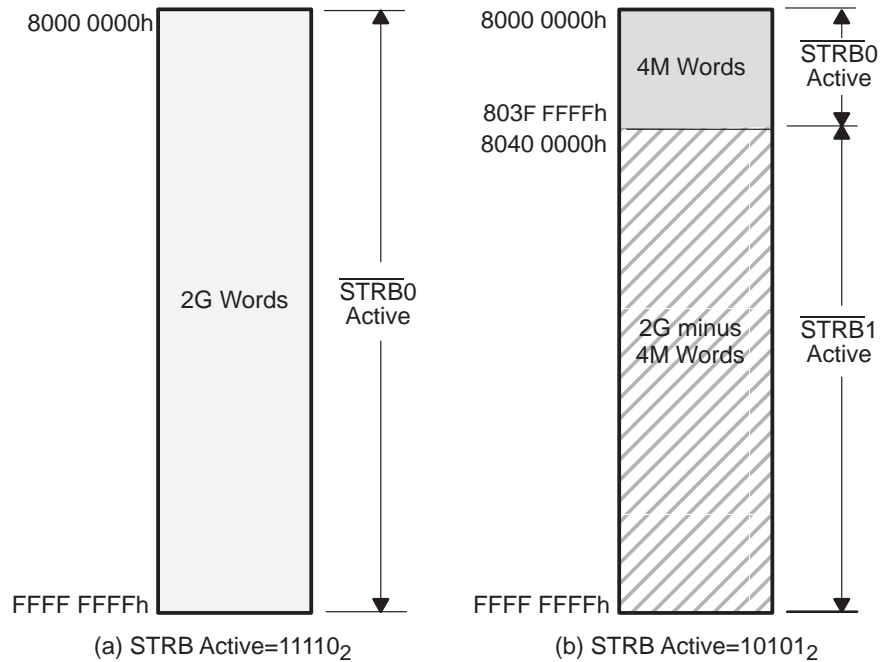

NOTE: Shown here are two examples for the global memory map. The entire 'C40 memory map (local and global) is shown in Figure 4–1 on page 4-3. Note that the highest address for $\overline{\text{LSTRB1}}$ (local bus) is 7FFF FFFFh.

Example (a) of Figure 9–4 shows the reset condition ($\text{STRB ACTIVE}=11110_2$). In this case, signal $\overline{\text{STRB0}}$ is active over the entire address range of the global memory bus (see Table 9–4 for fields and address ranges of STRB ACTIVE).

Example (b) of Figure 9–4 shows the global memory bus memory map when $\text{STRB ACTIVE}=10101_2$. In this case, $\overline{\text{STRB0}}$ is active from addresses 8000 0000h–803F FFFFh, and $\overline{\text{STRB1}}$ is active from addresses 8040 0000h–FFFF FFFFh (as shown in Table 9–4 for a STRB ACTIVE of 10101₂).

9.3.2 Page Size Operation

Within the memory range selected by any of the four strobe lines, the 'C4x external interface allows you to further divide the range into pages of selected length. This capability gives you great flexibility in the design of high-speed, high-density memory systems combined with slower peripheral devices; each time a page boundary is crossed, a cycle is inserted to allow external logic to reconfigure itself.

Each PAGESIZE field in the memory interface control register (shown in Figure 9–2 on page 9-7) works in the same manner to specify the page size for its corresponding strobe. Table 9–3 on page 9-9 illustrates the relationship between the PAGESIZE field and the bits of the address used to define the current page and the resulting page size. Page size begins at 256 words (with external address-bus bits 7–0 defining the address on a page, and ranges of up to 2G words ('C40) with external address bus bits 30–0 ('C40) defining the location on a page. The example in Figure 9–5 shows how a pagesize field value of 10110_2 is translated into bits 30–23 defining the current page and bits 22–0 defining an address on a page.

Figure 9–5. $\overline{\text{STRB}}_x$ PAGESIZE Fields Example

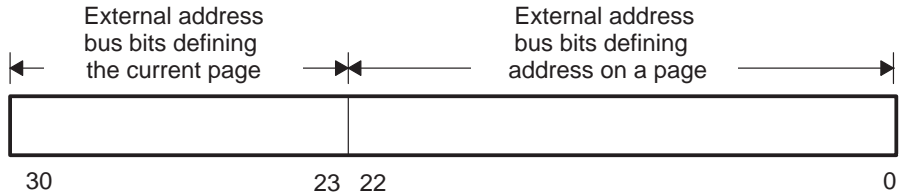

Note: This figure represents a $\overline{\text{STRB}}_x$ PAGESIZE field value of 10110_2 (as shown in Table 9–3).

Changing from one page to another causes a cycle to be inserted in the external access sequence, allowing external logic to reconfigure itself appropriately. For example, the extra cycle allows time for slower devices to get off the bus, thereby eliminating bus contention. The memory interface control logic keeps track of the address used for the last access for each $\overline{\text{STRB}}_x$. When an access begins, the PAGE signal corresponding to the active $\overline{\text{STRB}}_x$ goes inactive (high) if the access is to a new page. The PAGE0 and PAGE1 signals are independent of one another, each having its own page-size logic.

At reset, the page-control logic is initialized so that the extra cycle is inserted for the first access to the two strobe interfaces.

The control registers for the local memory interface function in the same way as the control registers for the global memory interface.

9.4 Programmable Wait States

The 'C4x has its own internal software-configurable ready-generation capability for each strobe. This software wait-state generator is controlled by configuring two fields in the global or local interface control register. Use the STRBx WTCNT field (bits 8–10 and 11–13) to specify the number of software wait states to generate, and use the STRBx SWW field (bits 6–7, and 4–5) to select one of the following four modes of wait-state generation:

- ❑ External $\overline{\text{RDY}}$ (SWW = 0). Wait states are generated solely by the external $\overline{\text{RDY}}$ line (software wait-states ignored).
- ❑ WTCNT-generated $\overline{\text{RDY}}_{\text{wcnt}}$ (SWW = 01₂). Wait states are generated solely by the software wait-state generator (external $\overline{\text{RDY}}$ ignored).
- ❑ Logical-OR of $\overline{\text{RDY}}$ and $\overline{\text{RDY}}_{\text{wcnt}}$ (SWW = 10₂). Wait states are generated with a logical OR of internal and external ready signals. Either signal can generate ready.
- ❑ Logical-AND of $\overline{\text{RDY}}$ and $\overline{\text{RDY}}_{\text{wcnt}}$ (SWW = 11₂). Wait states are generated with a logical AND of internal and external ready signals. Both signals must occur.

The four modes are used to generate the internal ready signal, $\overline{\text{RDY}}_{\text{int}}$, that controls accesses. As long as $\overline{\text{RDY}}_{\text{int}} = 1$, the current external access is extended. When $\overline{\text{RDY}}_{\text{int}} = 0$, the current access completes. Since the use of programmable wait states for both external interfaces is identical, only the global-bus interface is described in this section.

$\overline{\text{RDY}}_{\text{wcnt}}$ is an internally-generated ready signal. When an external access is begun, the value in WTCNT is loaded into a counter. WTCNT can be any value from 0 through 7. The counter is decremented every H1/H3 clock cycle until it becomes 0. Once the counter is cleared to 0, it remains cleared to 0 until the next access. When the counter is nonzero, $\overline{\text{RDY}}_{\text{wcnt}}=1$. When the counter is 0, $\overline{\text{RDY}}_{\text{wcnt}}=0$.

Table 9–6 is the truth table for each value of SWW, showing the different values at $\overline{\text{RDY}}$, $\overline{\text{RDY}}_{\text{wcnt}}$, and $\overline{\text{RDY}}_{\text{int}}$.

Note:

At reset, the 'C4x inserts seven wait states for each access to external memory. These wait states are inserted to ensure that the system can function with slow memories. To increase system performance when using fast external memories, you will need to decrease the number of wait states.

Table 9–6. Wait-State Generation for Each Value of S_{WW}

S _{WW} Value	RDY	$\overline{\text{RDY}}_{\text{wcnt}}$	$\overline{\text{RDY}}_{\text{int}}$	$\overline{\text{RDY}}_{\text{int}}$
00	0	0	0	$\overline{\text{RDY}}_{\text{int}}$ is dependent only upon $\overline{\text{RDY}}$. $\overline{\text{RDY}}_{\text{wcnt}}$ is ignored.
00	0	1	0	
00	1	0	1	
00	1	1	1	
01	0	0	0	$\overline{\text{RDY}}_{\text{int}}$ is dependent only upon $\overline{\text{RDY}}_{\text{wcnt}}$. RDY is ignored.
01	0	1	1	
01	1	0	0	
01	1	1	1	
10	0	0	0	$\overline{\text{RDY}}_{\text{int}}$ is the logical-OR (electrical AND because these signals are low true) of $\overline{\text{RDY}}$ and $\overline{\text{RDY}}_{\text{wcnt}}$.
10	0	1	0	
10	1	0	0	
10	1	1	1	
11	0	0	0	$\overline{\text{RDY}}_{\text{int}}$ is the logical-AND (electrical OR because these signals are low true) of $\overline{\text{RDY}}$ and $\overline{\text{RDY}}_{\text{wcnt}}$.
11	0	1	1	
11	1	0	1	
11	1	1	1	

9.5 Memory Interface Timing

Except for some cases that are covered in detail later in this chapter, the 'C4x offers a one-cycle external read and a pipeline external write. A write is considered a two-step operation: one cycle writes the data into the external memory port buffer and then another cycle moves the data from there to external memory.

Note:

From the perspective of the DMA or CPU, the write operation finishes in one cycle, and the DMA or CPU can proceed. However, if the next DMA or CPU access is to the same external bus, the DMA or CPU must wait, and the write is considered a two-cycle operation.

Figure 9–6. \overline{STRB} and \overline{RDY} Timing

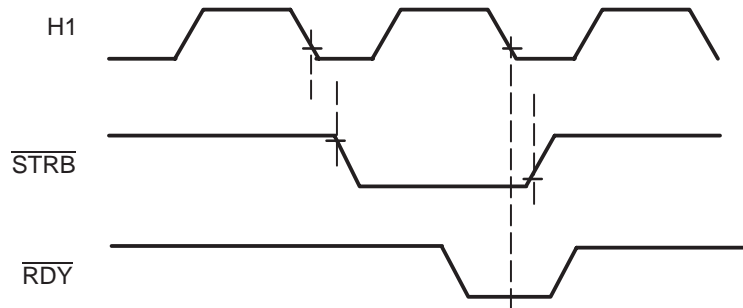

Note: The dotted lines emphasize the relationships between the signals.

As shown in Figure 9–6, \overline{STRB} changes on the falling edge of H1, and \overline{RDY} is sampled on the falling edge of H1. Throughout the other timing diagrams in this section, the following general rules apply to the logical timing of the parallel external interfaces:

- Changes of R/\overline{W} are always framed by \overline{STRB} .
- A page boundary crossing for a particular \overline{STRB} results in the corresponding PAGE signal going high for one cycle.
- R/\overline{W} transitions always occur on the rising edge of H1.
- \overline{STRB} transitions always occur on the falling edge H1.
- \overline{RDY} is always sampled on the falling edge H1.
- Data is always sampled during a read on the falling edge of H1.
- Data is always driven out during a write on the falling edge of H1.

- Data is always stopped from being driven during a write on the rising edge of H1.
- The status and PAGE signals, following a read, change on the falling edge of H1. The address also changes on H1's falling edge.
- The status and PAGE signals, following a write, change on the falling edge of H1; the address changes on the rising edge of H1.
- The fetch of an interrupt vector over an external interface is identified by the status signals for that interface (STAT or LSTAT) as a data read.
- The interlocked operation status signals ($\overline{\text{LOCK}}$ and $\overline{\text{LLOCK}}$) have the same timing as the STAT and LSTAT status signals, respectively.
- Any time PAGE goes high, $\overline{\text{STRB}}$ goes high.

Note:

When no external port is accessing memory (idle status), the control lines are inactive ($\overline{\text{RDY}}$ is ignored, $\overline{\text{STRB}}$ is high, and the STATx lines become high), the address lines keep the last value used in the pins, and the data lines become high-impedance. This can be seen in Figure 9–16.

Figure 9–7 illustrates a read, read, write sequence. This figure assumes that all three accesses are to the same page and that they are $\overline{\text{STRB1}}$ accesses. This timing diagram illustrates that:

- Back-to-back reads to the same page are single-cycle accesses.
- $\overline{\text{STRB}}$ stays low during back-to-back reads.
- When the transition from a read to a write is done, $\overline{\text{STRB}}$ goes high for one cycle to frame the $\overline{\text{R/W}}$ signal changing.

Figure 9–7. Read Same Page, Read Same Page, Write Same Page Sequence

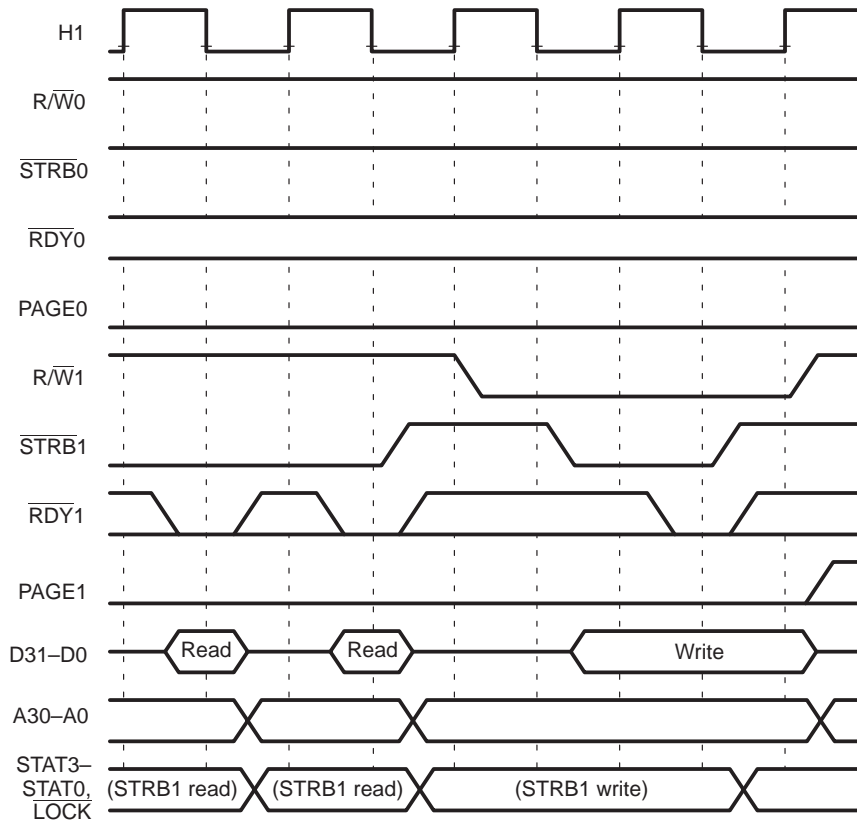

Note: Strobe and Ready Further Defined

Strobe and ready are discussed from the application viewpoint in TMS320C4x General-Purpose Applications User's Guide.

Figure 9–8 shows that:

- ❑ To prevent unwanted writes, $\overline{\text{STRB}}$ goes high between back-to-back writes to disable the memory while the address changes.
- ❑ As in Figure 9–7, $\overline{\text{STRB}}$ goes high between a write and a read, and it frames the R/ $\overline{\text{W}}$ transition.
- ❑ A read following a write on the same bus takes two cycles. This happens regardless of whether or not the read is on the same strobe and/or page.
- ❑ Consecutive writes take two cycles.

Figure 9–8. Write Same Page, Write Same Page, Read Same Page Sequence

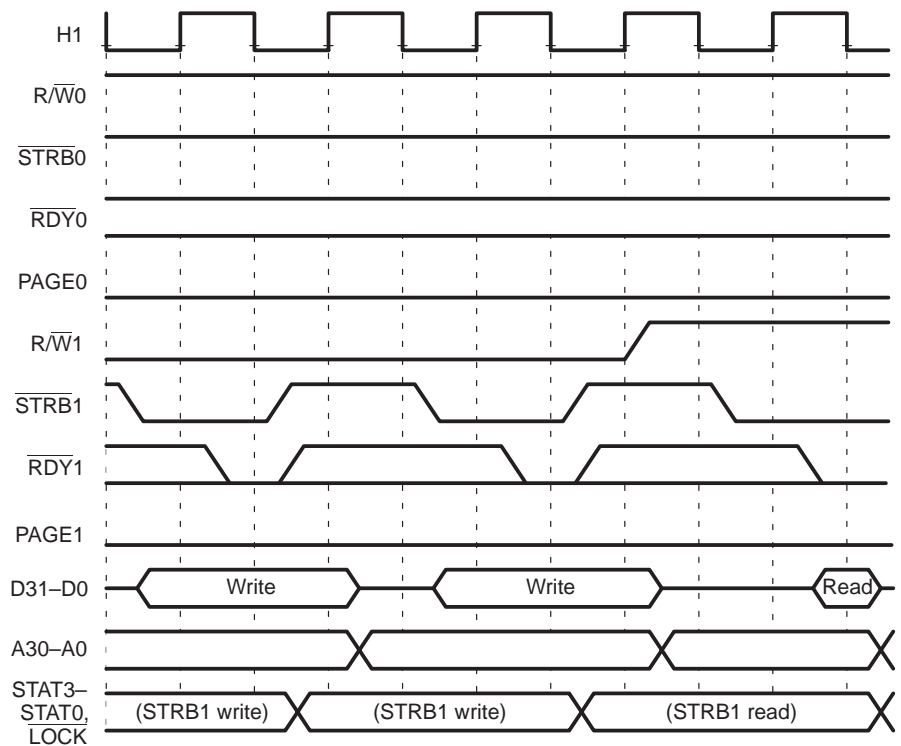

Figure 9–9 shows that going from one page to another on back-to-back reads causes:

- An extra cycle to be inserted to allow the next memory to be selected
- The transition to be signaled by PAGE going high for one cycle
- $\overline{\text{STRB1}}$ to go high for one cycle

Figure 9–9. Read Same Page, Read Different Page, Read Same Page Sequence

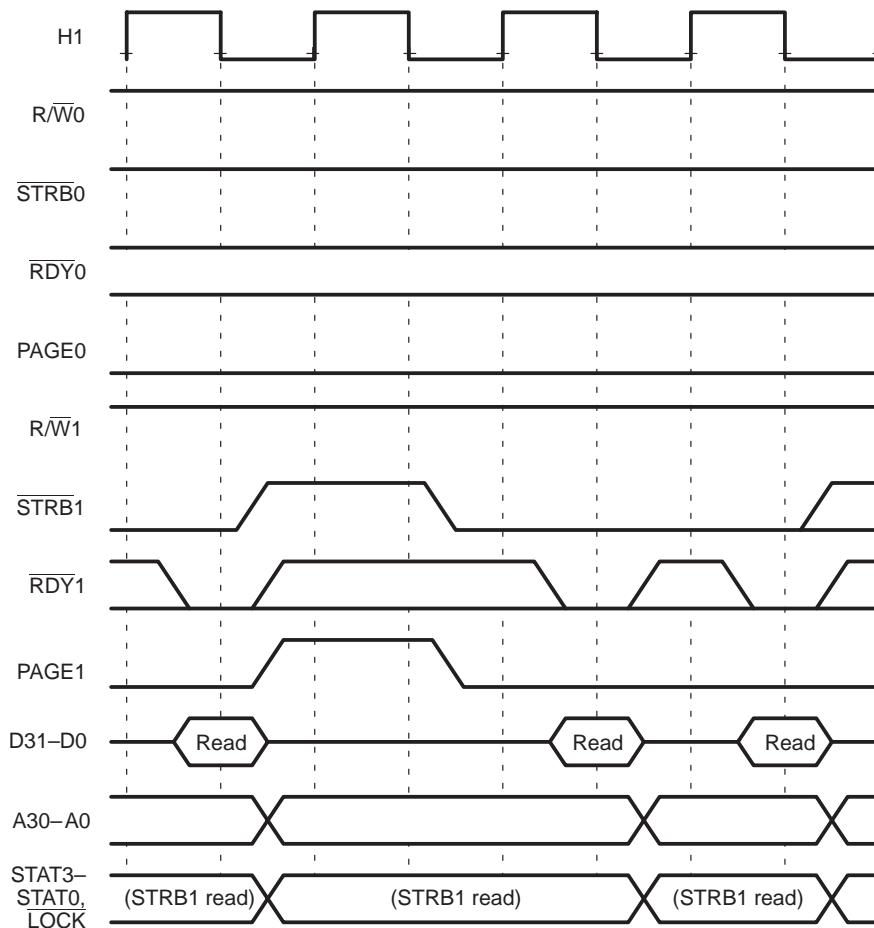

Figure 9–10 shows that on back-to-back writes, when a page switch occurs:

- PAGE1 signals this occurrence by going high for one cycle.
- No extra cycle is inserted, because write cycles exhibit an inherent one-half H1 cycle setup of address information before $\overline{\text{STRB}}$ goes low.

Figure 9–10. Write Same Page, Write Different Page, Write Same Page Sequence

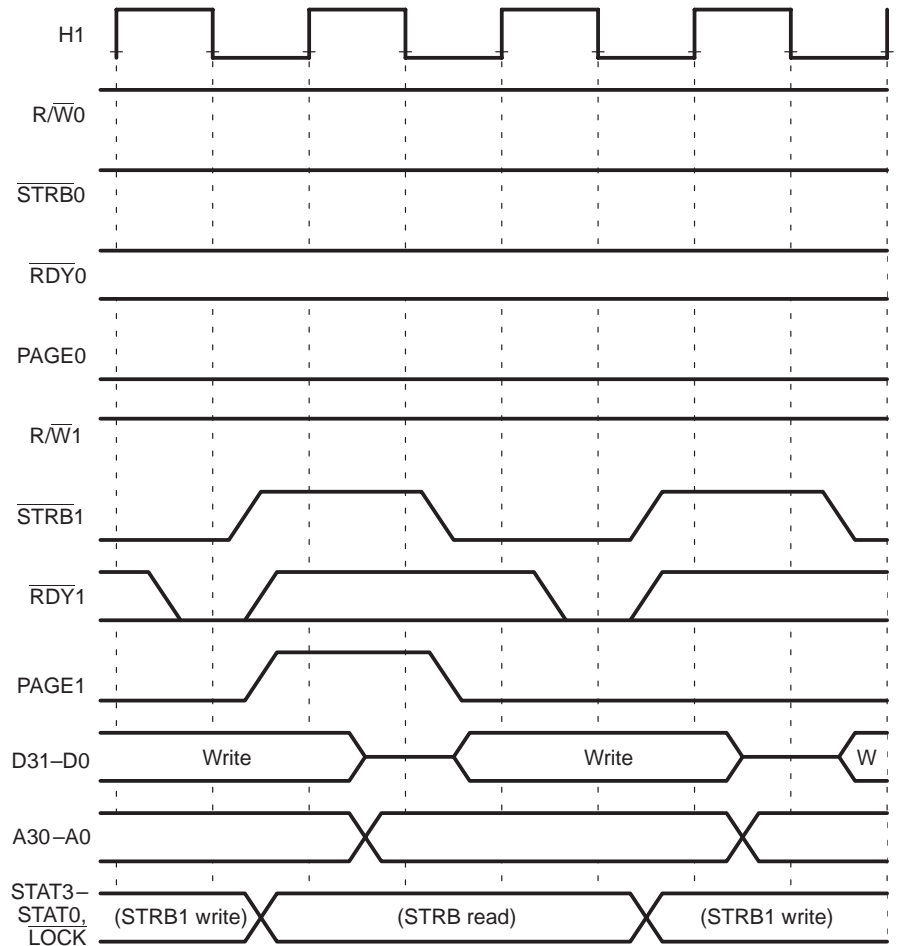

Figure 9–11. Write Same Page, Read Different Page, Write Different Page Sequence

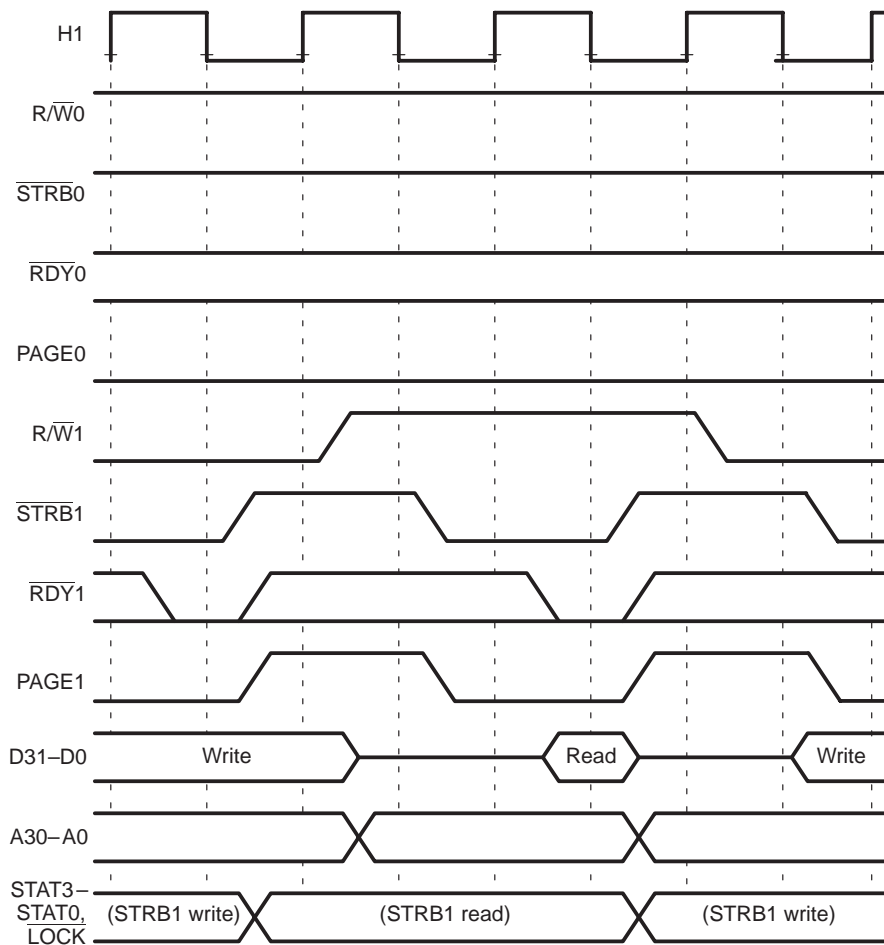

Figure 9–12. Read Different Page, Read Different Page, Write Same Page Sequence

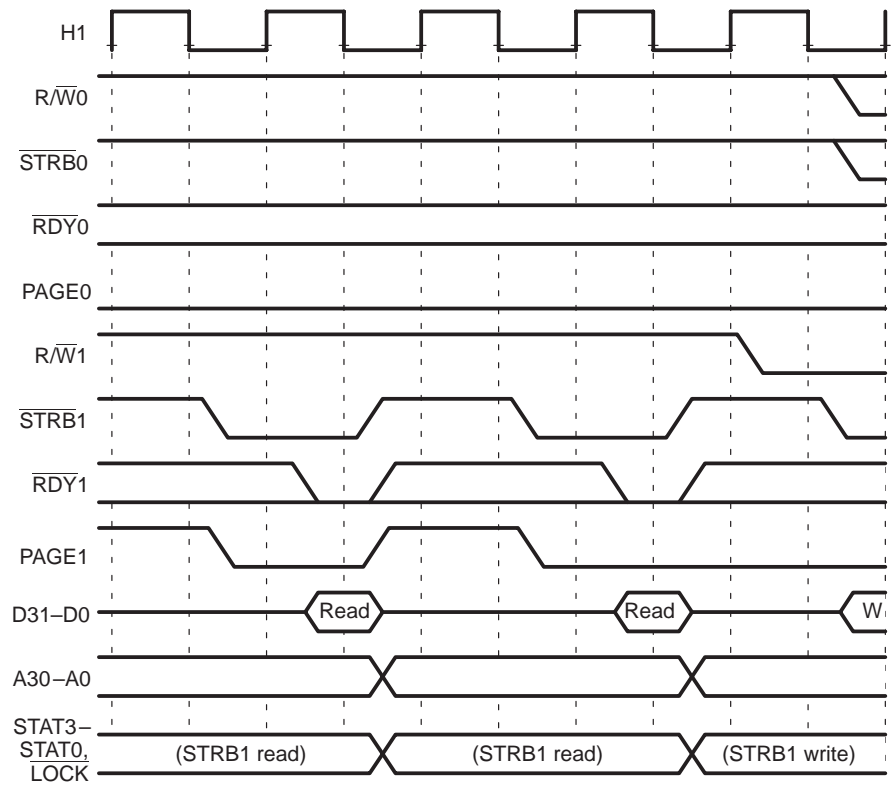

Figure 9–13. Write Different Page, Write Different Page, Read Same Page Sequence

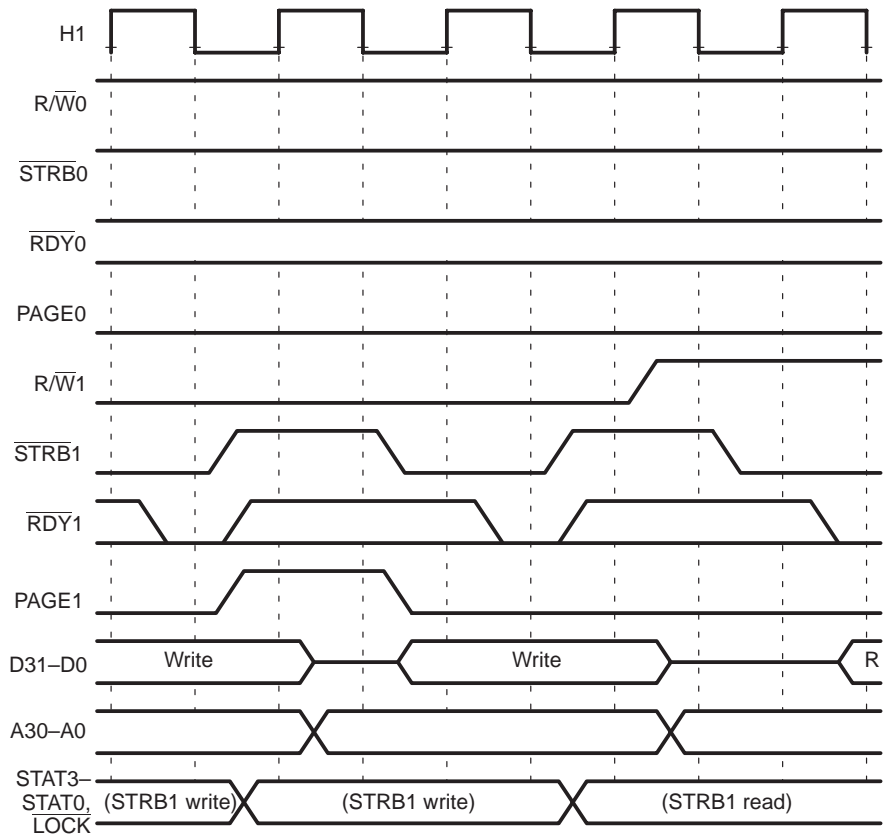

Figure 9–14. Read Same Page, Write Different Page, Read Different Page Sequence

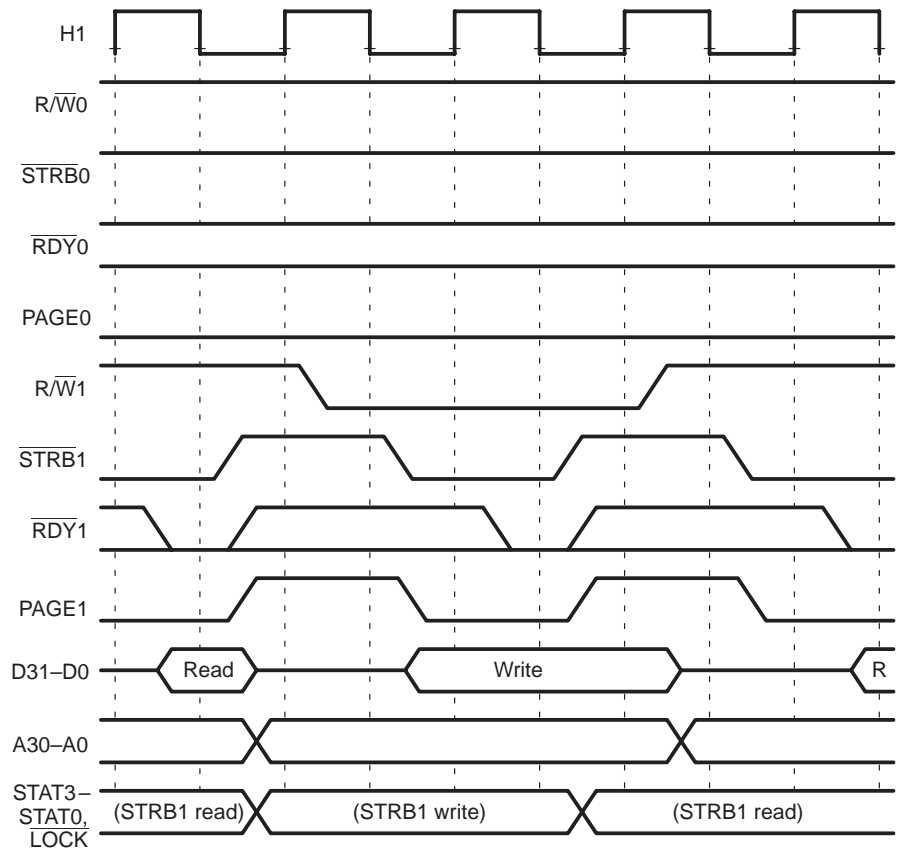

Figure 9–15 through Figure 9–19 illustrate idle bus cycles. Idle bus cycle timing is similar to read cycle timing. The primary differences are that no data is read, $\overline{\text{STRB}}$ is held high, and $\overline{\text{RDY}}$ is ignored.

Figure 9–15. Read Same Page, Idle One Cycle, Read Same Page Sequence

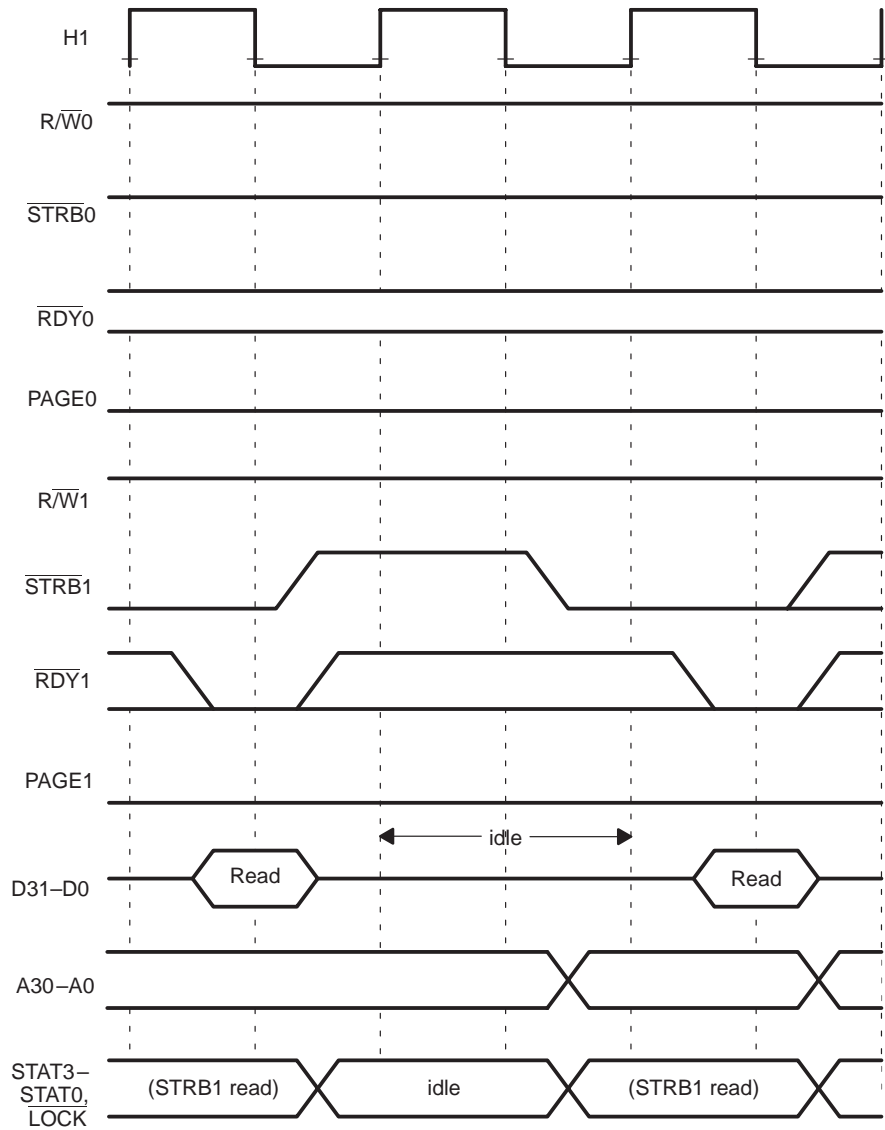

Figure 9–16. Write Same Page, Idle One Cycle, Write Different Page Sequence

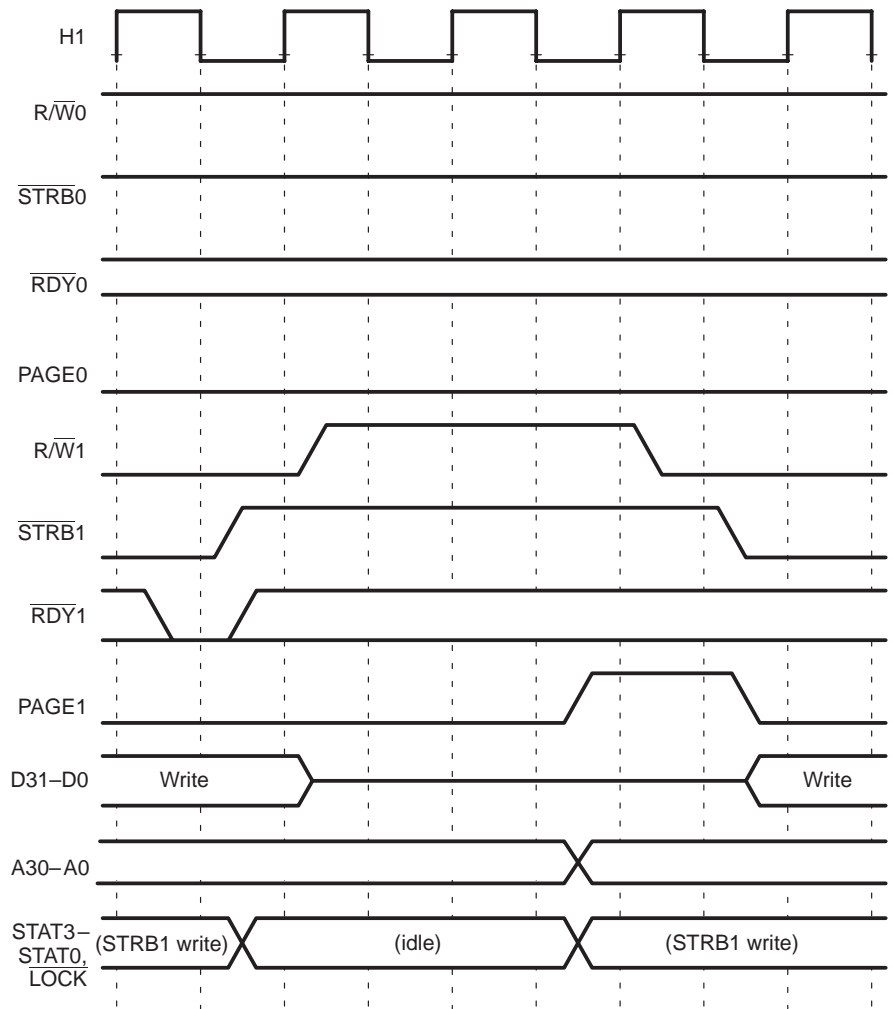

Figure 9–17. Idle, Read Different Page, Idle Sequence

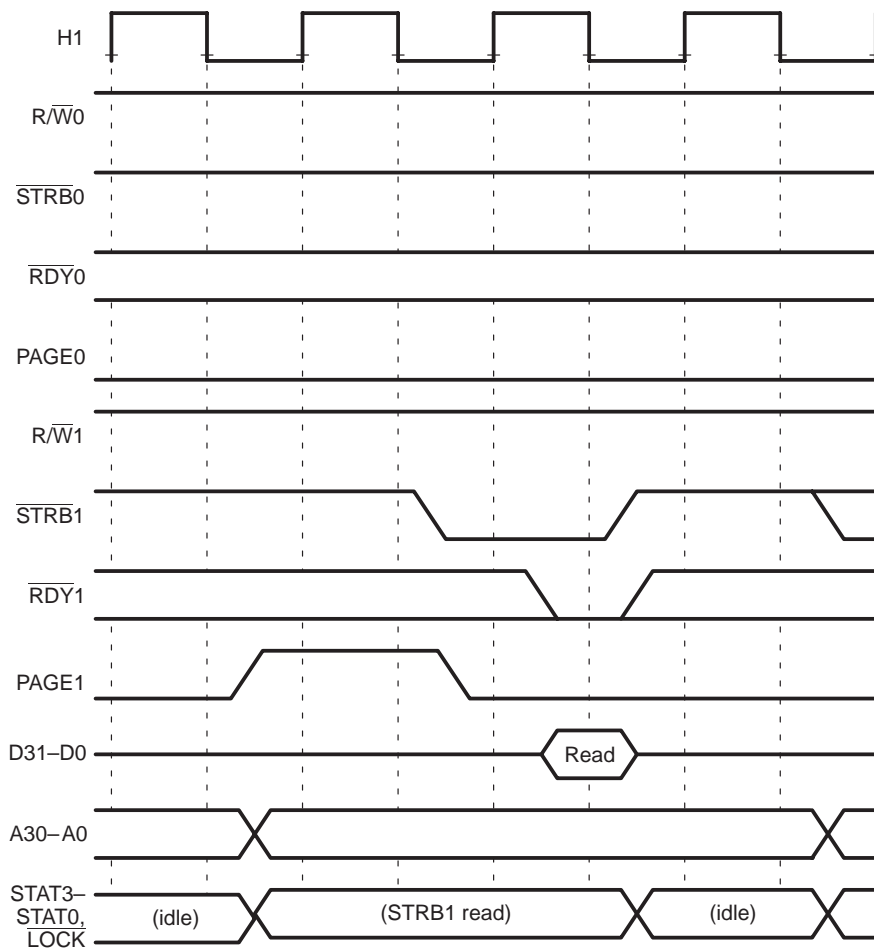

Figure 9–18. Idle, Write Same Page, Idle Sequence

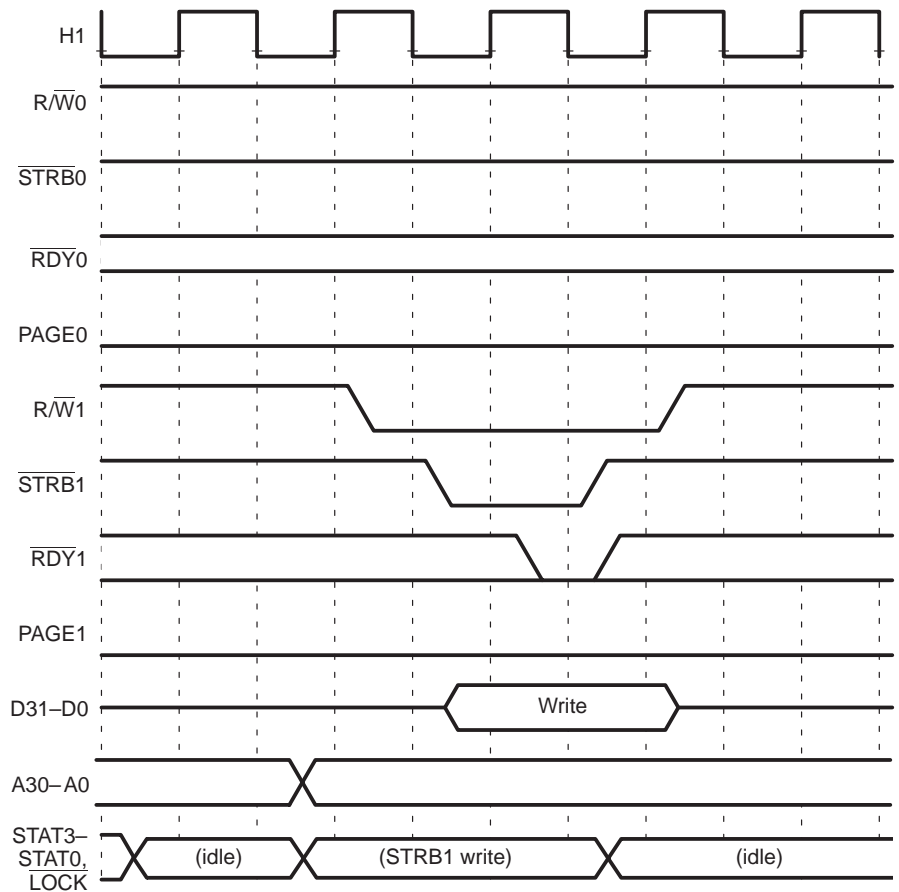

Figure 9–19. Write Different or Same Page, Idle, Idle Sequence

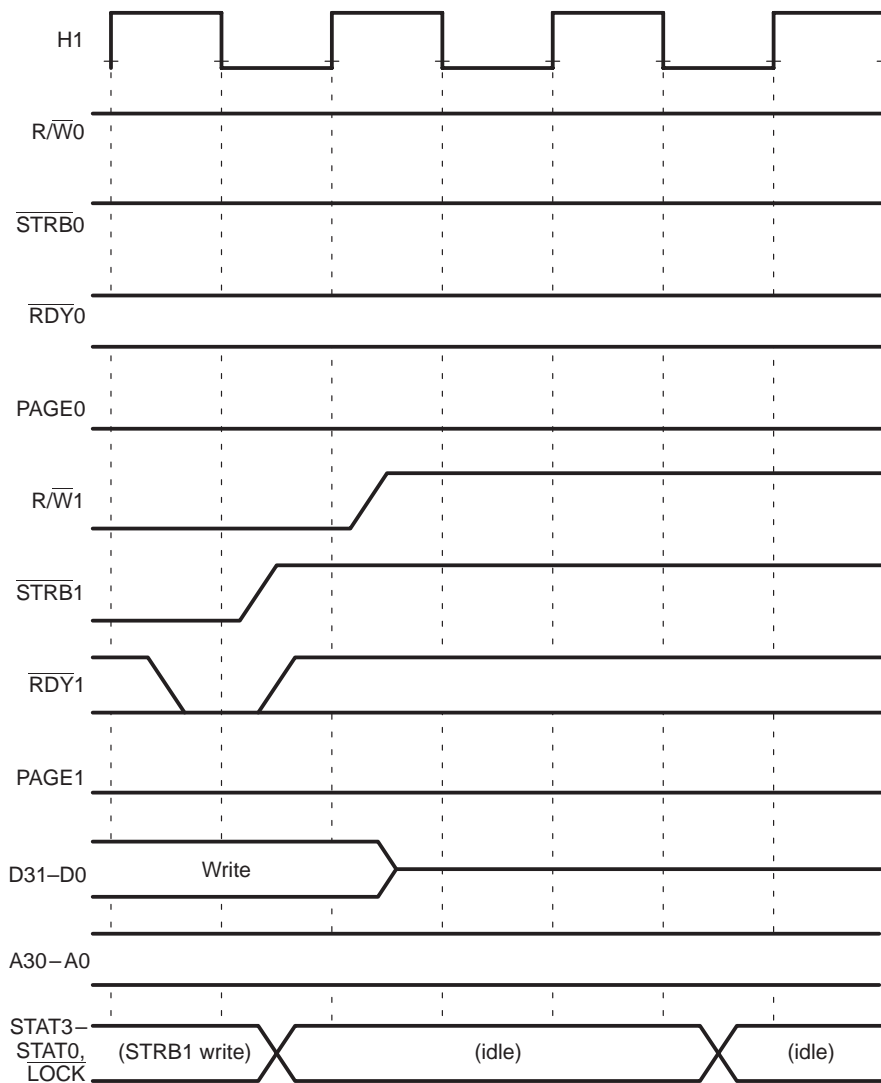

Figure 9–20 illustrates a $\overline{\text{STRB1}}$ read followed by a $\overline{\text{STRB0}}$ read when $\text{STRB SWITCH}=0$. This mode allows the reads to be back-to-back, with no cycles inserted between them when they are activating different strobes.

Figure 9–20. Read Same Page on $\overline{\text{STRB1}}$, $\overline{\text{STRB0}}$, and on $\overline{\text{STRB1}}$ Sequence When $\overline{\text{STRB SWITCH}} = 0$

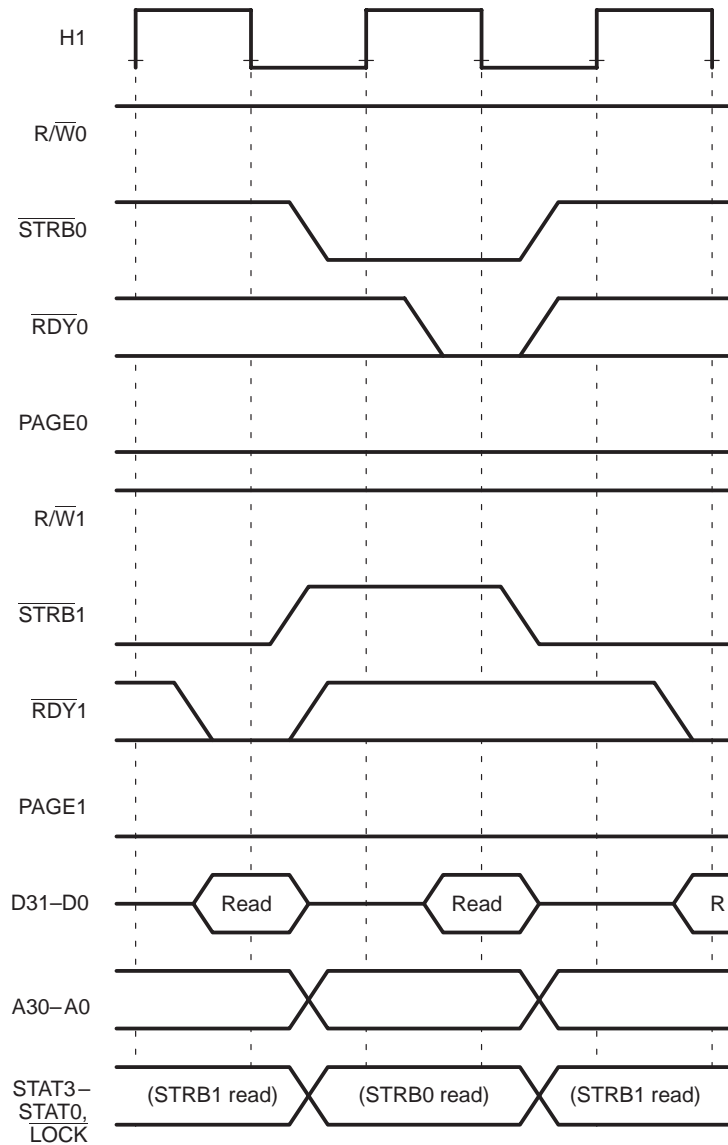

Figure 9–21 is similar to Figure 9–20 except that the second $\overline{\text{STRB1}}$ read is from a different page than the first.

Figure 9–21. Read Same Page on $\overline{\text{STRB1}}$, $\overline{\text{STRB0}}$, Read Different Page on $\overline{\text{STRB1}}$ Sequence When $\overline{\text{STRB SWITCH}} = 0$

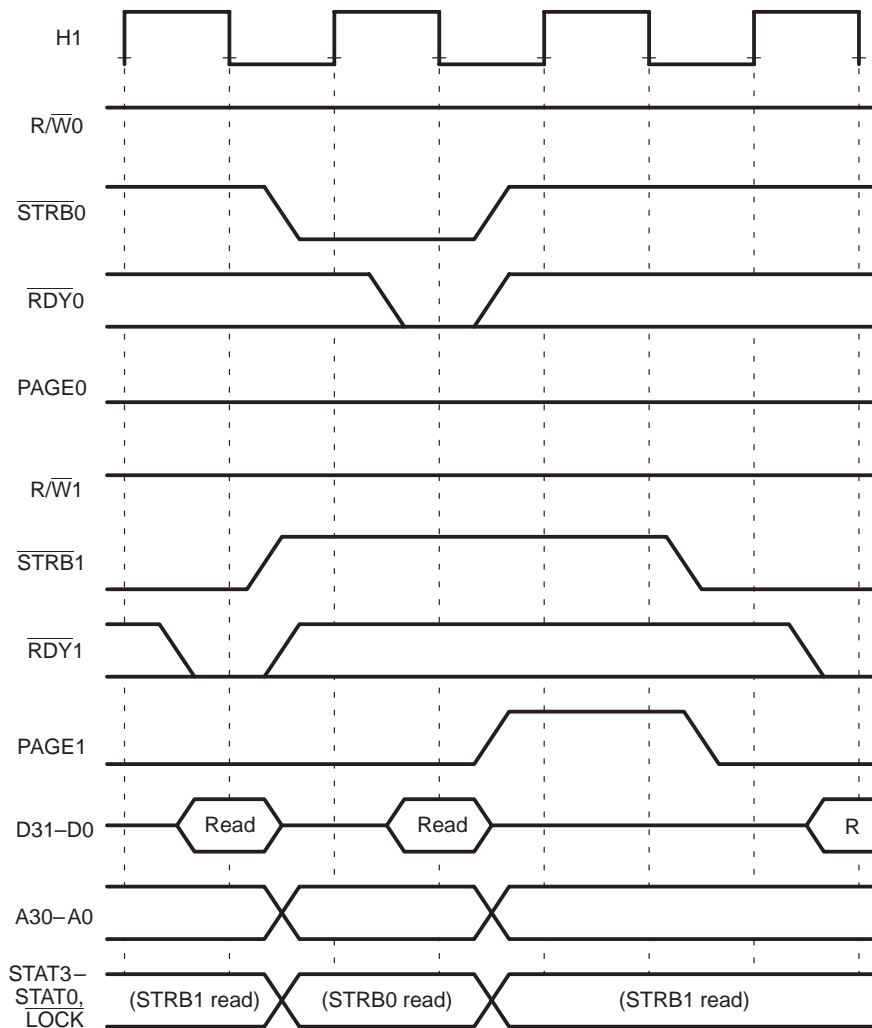

Figure 9–22 illustrates a $\overline{\text{STRB1}}$ read followed by a $\overline{\text{STRB0}}$ read when $\text{STRB SWITCH}=1$. In this mode, a cycle is inserted between back-to-back reads that activate different strobes. Some memory configurations require this cycle between strobe transitions to prevent bus conflicts during back-to-back reads on different strobes.

Figure 9–22. Read Same Page on $\overline{\text{STRB1}}$, $\overline{\text{STRB0}}$, and on $\overline{\text{STRB1}}$ Sequence When $\text{STRB SWITCH} = 1$

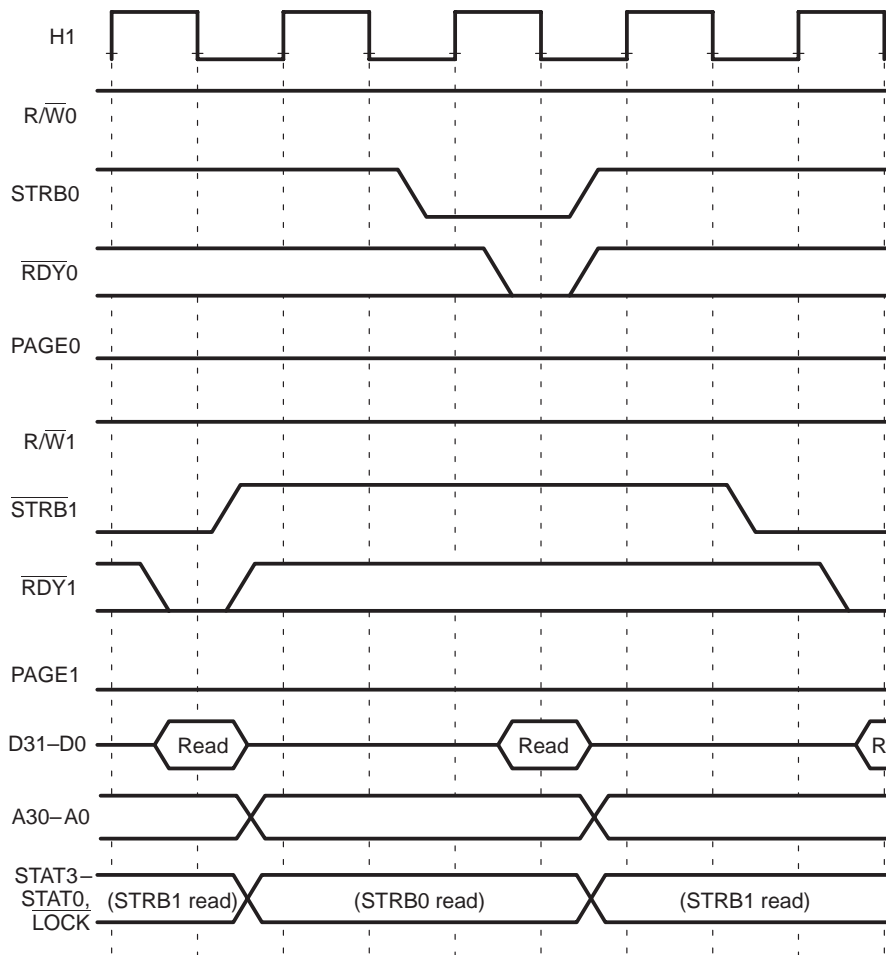

Figure 9–23 is similar to Figure 9–22 except that the second $\overline{\text{STRB1}}$ read is from a different page than the first.

Figure 9–23. Read Same Page on $\overline{\text{STRB1}}$, $\overline{\text{STRB0}}$, Read Different Page on $\overline{\text{STRB1}}$ Sequence When $\overline{\text{STRB SWITCH}} = 1$

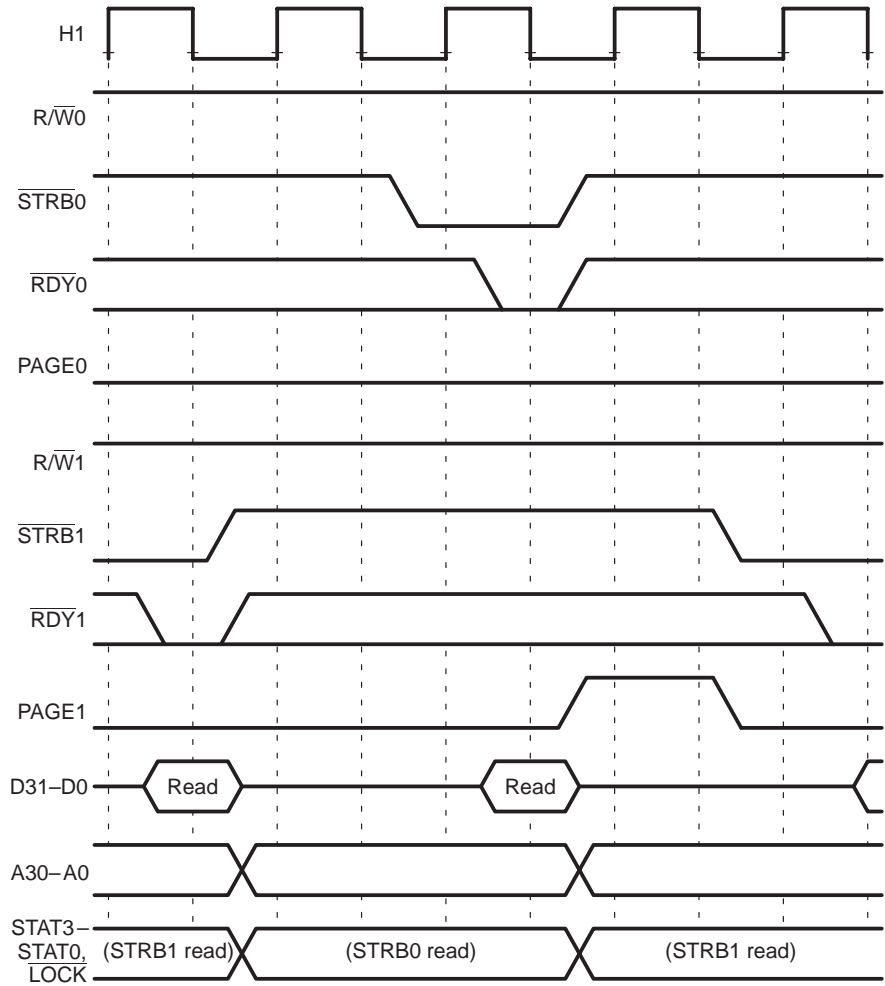

Figure 9–24. Write Same Page on $\overline{\text{STRB1}}$, $\overline{\text{STRB0}}$, Read Same Page on $\overline{\text{STRB1}}$ Sequence

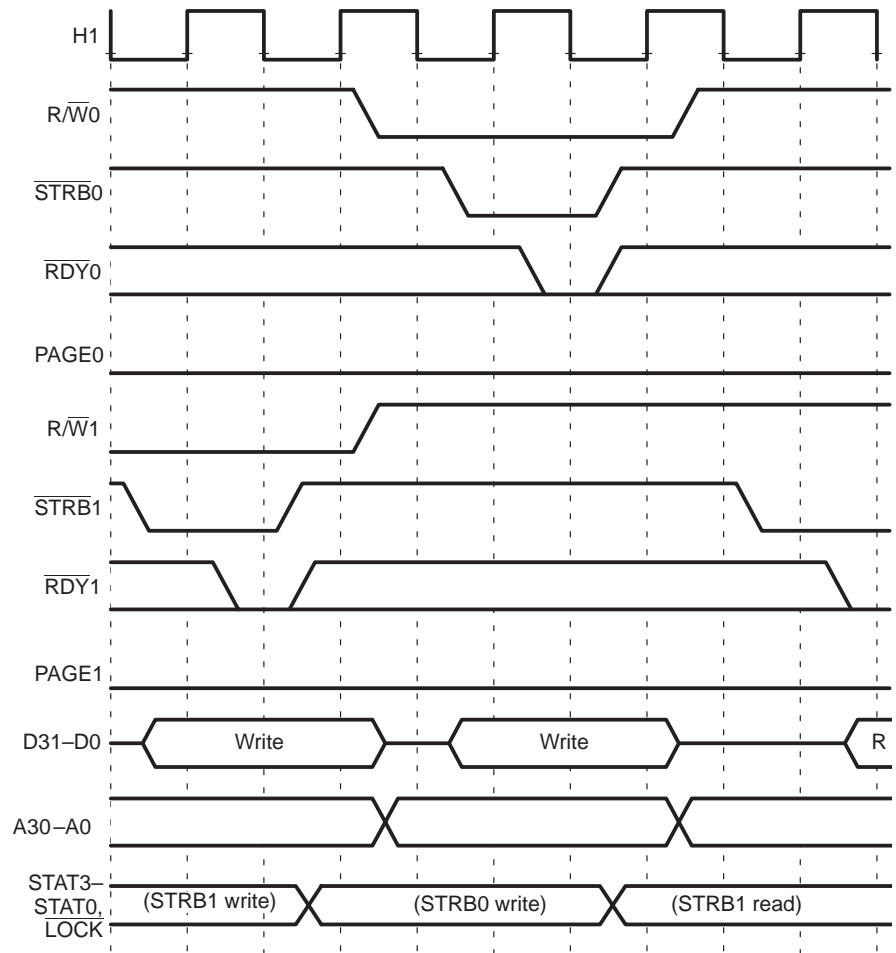

Figure 9–25 and Figure 9–26 show one wait-state read and write operations, respectively.

Figure 9–25. Read With One Wait State

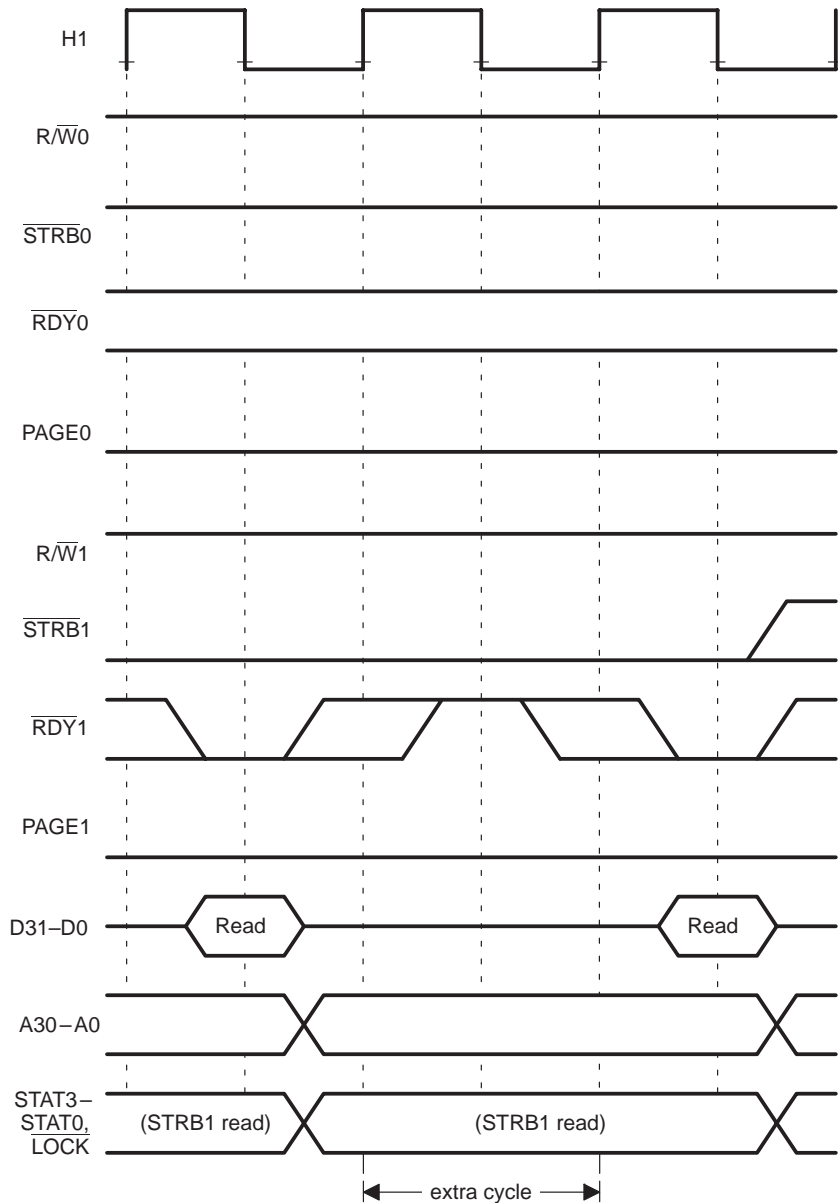
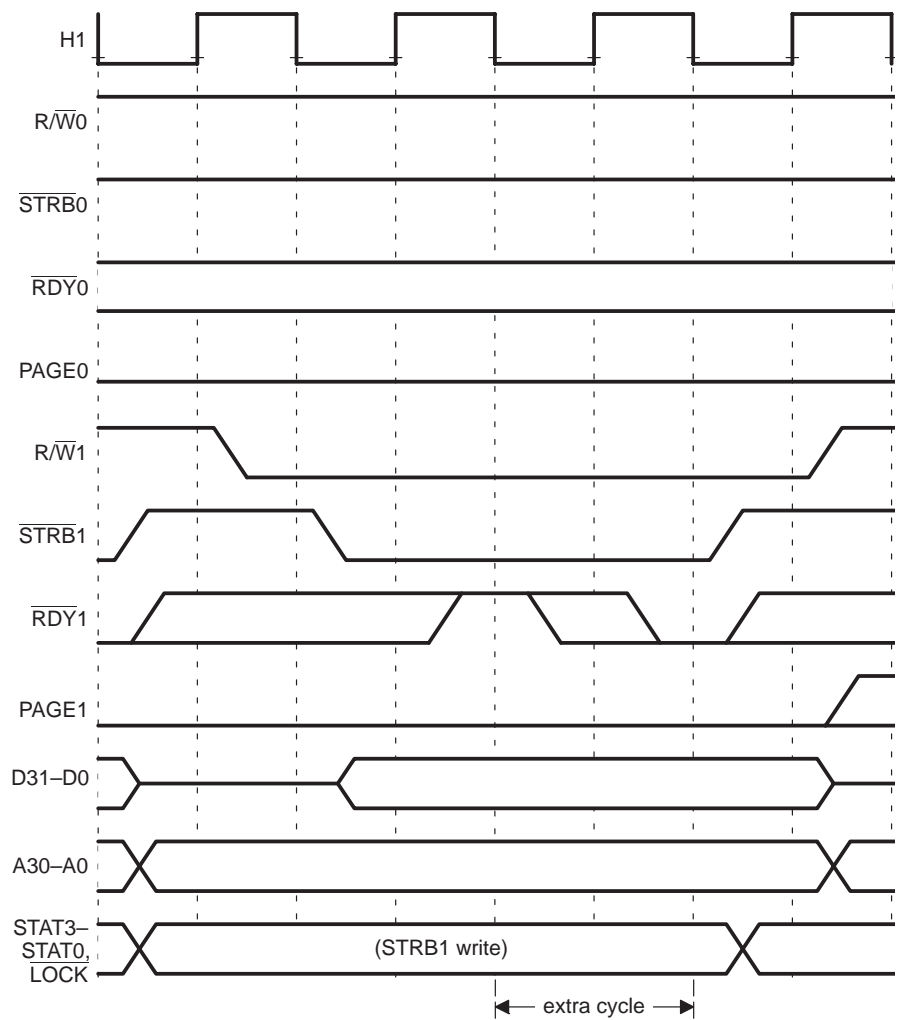

Figure 9–26. Write With One Wait State



9.6 Using Enable Signals to Control Signal Groups

Figure 9–27. Using Enable Signals to Put Signal Groups in a High-Impedance State

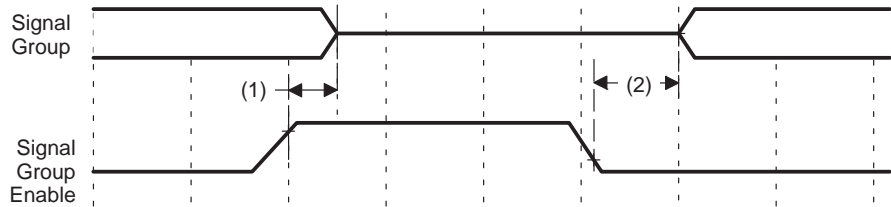

Figure 9–27 shows an enable signal controlling the corresponding signal group. For example, signal \overline{DE} controls the global external-interface data signals. The enable signals are unsynchronized inputs that turn off the corresponding output buffers. After the enable signal goes high plus timing (1) in Figure 9–27, the corresponding signal group goes into high-impedance. Then, after the enable signal goes low plus timing (2) in Figure 9–27, the signal group comes out of high-impedance. If the signal group is already in a high-impedance state before the enable signal goes high, the group will come out of the high-impedance state (when the enable signal goes low) only if the signal group is in a state requiring it to do so. For example, a data bus that was not being driven will be driven after being enabled, if an access is pending for the data bus.

Note:

If you intend to use internally generated wait states, be certain that no data is read from or written to the bus when it is disabled. This is because it is possible for a bus to be in the high-impedance state with internally generated wait states. In this case, data that is written will not be seen externally, and data that is read will be whatever value is sampled on the high-impedance bus.

9.7 Interlocked Operations

One of the most common parallel processing configurations is the sharing of global memory by multiple processors. For multiple processors to access this global memory and share data in a coherent manner, some sort of arbitration or handshaking is necessary. 'C4x interlocked operations meet this requirement for arbitration. More details are given in Section 9.7.5 on page 9-44.

Five 'C4x instructions are referred to as interlocked operations. Through the use of external signals, these instructions provide powerful synchronization mechanisms. They also guarantee integrity of communication and result in a high-speed operation. The interlocked-operation instruction group is listed in Table 9–7.

Table 9–7. Interlocked Operations

Instruction	Description	Operation
LDFI	Load floating-point value from memory into a register; interlocked when <i>external</i> memory accessed	Signal interlocked src → dst
LDII	Load integer from memory into a register; interlocked when <i>external</i> memory accessed	Signal interlocked src → dst
SIGI	Load floating-point value from memory into a register; interlocked when <i>external</i> memory accessed	Signal interlocked Clear interlock
STFI	Store floating-point value from a register to memory; interlocked when <i>external</i> memory accessed	src → dst Clear interlock
STII	Store integer from a register to memory; interlocked when <i>external</i> memory accessed	src → dst Clear interlock

The interlocked operations use the global- and local-bus pins, $\overline{\text{LOCK}}$ and $\overline{\text{LLOCK}}$, to reflect a currently executing interlocked operation. This signal is active (low) when any of the interlocked instructions in Table 9–7 are executing.

The external timing for interlocked loads and stores is the same as for standard loads and stores. You can extend interlocked loads and stores like standard accesses by using the appropriate ready signal ($\overline{\text{RDYx}}$ or $\overline{\text{LRDYx}}$).

9.7.1 LDFI and LDII

The **LDFI** and **LDII** instructions perform the following actions:

- 1) Pull $\overline{\text{(L)LOCK}}$ low.
- 2) Execute an LDF or LDI instruction.
- 3) Extend the read cycle until the appropriate ready signal is received. Complete the instruction.
- 4) Leave $\overline{\text{(L)LOCK}}$ active low until changed by an STFI, STII, or SIGI.

The read/write operation is identical to any other read/write cycle except for the special use of $\overline{\text{(L)LOCK}}$. The *src* operand for LDFI and LDII is always a direct or indirect memory address. $\overline{\text{(L)LOCK}}$ is set to 0 only if the *src* is located off-chip (i.e., $\overline{\text{STRB}}$ or $\overline{\text{LSTRB}}$ is active). If on-chip memory is accessed, then $\overline{\text{(L)LOCK}}$ is not asserted, and the operation is as an LDF or LDI from internal memory.

9.7.2 STFI and STII

The **STFI** and **STII** instructions perform the following operations:

- 1) Begin a write cycle. The state of $\overline{\text{(L)LOCK}}$ does not change. If it is low, an interlocked operation occurs. If high, the operation is as if an STF or STI is performed (not interlocked).
- 2) Execute an STF or STI instruction and extend the write cycle until the appropriate ready is signaled.
- 3) After the write cycle, bring $\overline{\text{(L)LOCK}}$ inactive (high).

As in the case for LDFI and LDII, the *dst* of STFI and STII affects $\overline{\text{(L)LOCK}}$. If *dst* is located off-chip ($\overline{\text{STRB}}(0,1)$ or $\overline{\text{LSTRB}}(0,1)$ is active), $\overline{\text{(L)LOCK}}$ is set to a 1. If on-chip memory is accessed, then $\overline{\text{(L)LOCK}}$ is not asserted, and the operations are as a STF or STI to internal memory.

9.7.3 SIGI

The SIGI instruction can be used in a variety of ways. In some applications, you may wish to modify semaphores externally, perhaps with special-purpose logic. If so, SIGI can be used to perform a single-cycle interlocked access of the semaphore. The SIGI instruction can also be used simply to perform an external read and to signal that a particular point in your code has been reached.

The **SIGI** instruction functions as follows:

- 1) Pulls $\overline{(\text{L})\text{LOCK}}$ low
- 2) Executes an LDI instruction
- 3) Extends the read cycle until the appropriate ready signal is received. Completes the instruction
- 4) Brings $\overline{(\text{L})\text{LOCK}}$ back inactive high

Interlocked operations can be used to implement a busy-waiting loop, to manipulate a multiprocessor counter, to implement a simple semaphore mechanism, or to perform synchronization between two 'C4xs. The following examples illustrate the usefulness of the interlocked operations instructions.

9.7.4 Interlocked Examples

Examples in this section show you how interlocked operations can be used to implement:

- A busy-waiting loop to synchronize processors at the software level (Example 9–1, page 9-42)
- A counter shared between cooperative processors that defines the number of times a task should be done by the processors (Example 9–2 on page 9-42)
- Semaphores to ease the programming of critical sections (Example 9–3 and Example 9–4 on page 9-43)

Example 9–1 shows the implementation of a busy-waiting loop. The 'C4x stays in this loop until another processor writes a 0 in @LOCK. If location LOCK is the interlock for a critical section of code, and a nonzero means the lock is busy, the algorithm for a busy-waiting loop can be used as shown.

Example 9–1. Busy-Waiting Loop

```

LDI    1,R0      ;Put 1 in R0
L1:    LDII   @LOCK,R1 ;Load lock value into R1
      STII   R0,@LOCK ;Set lock value to 1
      BNZ   L1      ;If R1 (previous lock value) is not
                       ;0, read it again
    
```

Example 9–2 shows how a location COUNT may contain a count of the number of times a particular operation must be performed. This operation may be performed by any processor in the system. If the count is zero, the processor waits until it is nonzero before beginning processing. The example also shows the algorithm for modifying COUNT correctly.

Example 9–2. Task Counter Manipulation

```

LDI    0,R0
WAIT  LDII   @COUNT,R1 ;Read current value of counter
      BZD   WAIT      ;If COUNT = 0, try again
      LDNZ  1,R0      ;If COUNT not zero, decrement it
      SUBI  R0,R1
      STII  R1,@COUNT ;Update COUNT
    
```

Figure 9–28 illustrates multiple 'C4xs sharing global memory and using interlocked instructions as shown in Example 9–3 and Example 9–4.

Figure 9–28. Multiple 'C4x Devices Sharing Global Memory

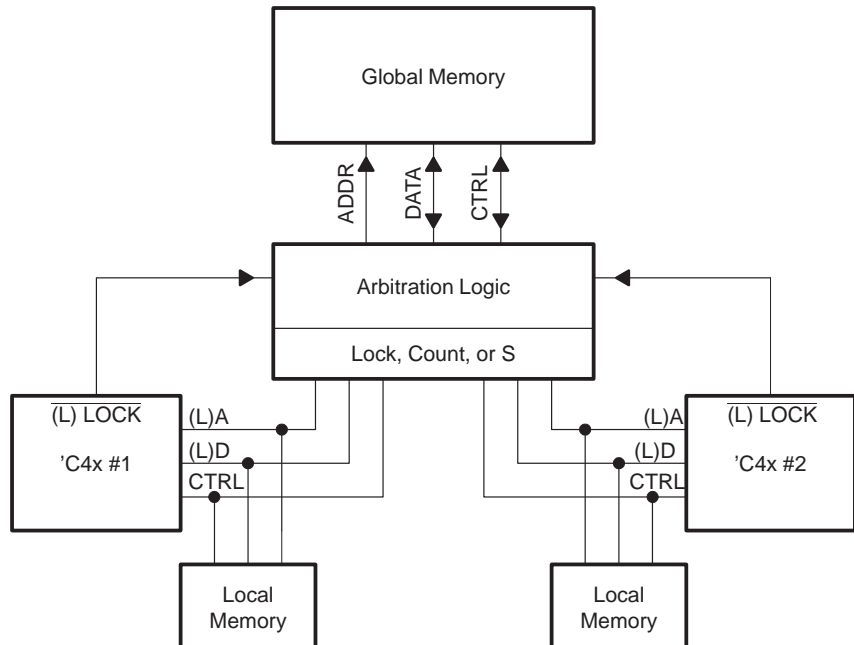

Example 9–3. Implementation of V(S)

```
V: LDII  @S,R0
    ADDI  1,R0
    STII  R0,@S ; S + 1 → S
```

Example 9–4. Implementation of P(S)

```
LDI  0,R0
P: LDII  @S,R1      ;Read semaphore's current value
    BZD  P          ;If S = 0, go to P and try again
    LDNZ 1,R0      ;If S is not 0, decrement it
    SUBI  R0,R1
    STII  R1,@S    ;Update S
```

Sometimes it may be necessary for several processors to access some shared data or other common resources. The portion of code that must access the shared data is called a *critical section*.

To ease the programming of critical sections, semaphores may be used. Semaphores are variables that can take only nonnegative integer values. Two primitive, indivisible operations are defined on semaphores (with S being a semaphore):

```
V(S): S + 1 → S
P(S): P: if (S == 0), go to P
        else S - 1 → S
```

Indivisibility of V(S) and P(S) means that when these processes access and modify the semaphore S, they are the only processes doing so.

To enter a critical section, a P operation is performed on a common semaphore, for example, on S (S is initialized to 1). The first processor performing P(S) will be able to enter its critical section. All other processors are blocked because S has become 0. After leaving its critical section, the processor performs a V(S), thus allowing another processor to execute P(S) successfully.

The 'C4x code for V(S) is shown in Example 9–3, and code for P(S) is shown in Example 9–4. Compare the code in Example 9–4 to the code in Example 9–2, which does not use semaphores.

9.7.5 Bus-Lock Pins and Bus Timing

The timing of the $\overline{\text{LOCK}}$ and $\overline{\text{LLOCK}}$ pins is the same as the timing of the STAT(3–0) and LSTAT(3–0) pins. The LDII, LDFI, ,STII, STFI, and SIGI instructions manipulate the bus-lock signals *only* when an external memory access is made.

LDII, LDFI, and SIGI all clear $\overline{\text{LOCK}}$ or $\overline{\text{LLOCK}}$ to zero at the beginning of the read cycle with H1 falling. STII, STFI, and SIGI all set $\overline{\text{LOCK}}$ or $\overline{\text{LLOCK}}$ to one at the end of the access cycle on the falling edge of H1. Interlocked instructions are explained in Section 9.7.

Figure 9–29 through Figure 9–32 show bus timing characteristics for several external accesses using STII, LDII, STFI, LDFI, and SIGI.

Figure 9–29 is an example of an LDII or LDFI external access.

Figure 9–29. LDII or LDFI External Access

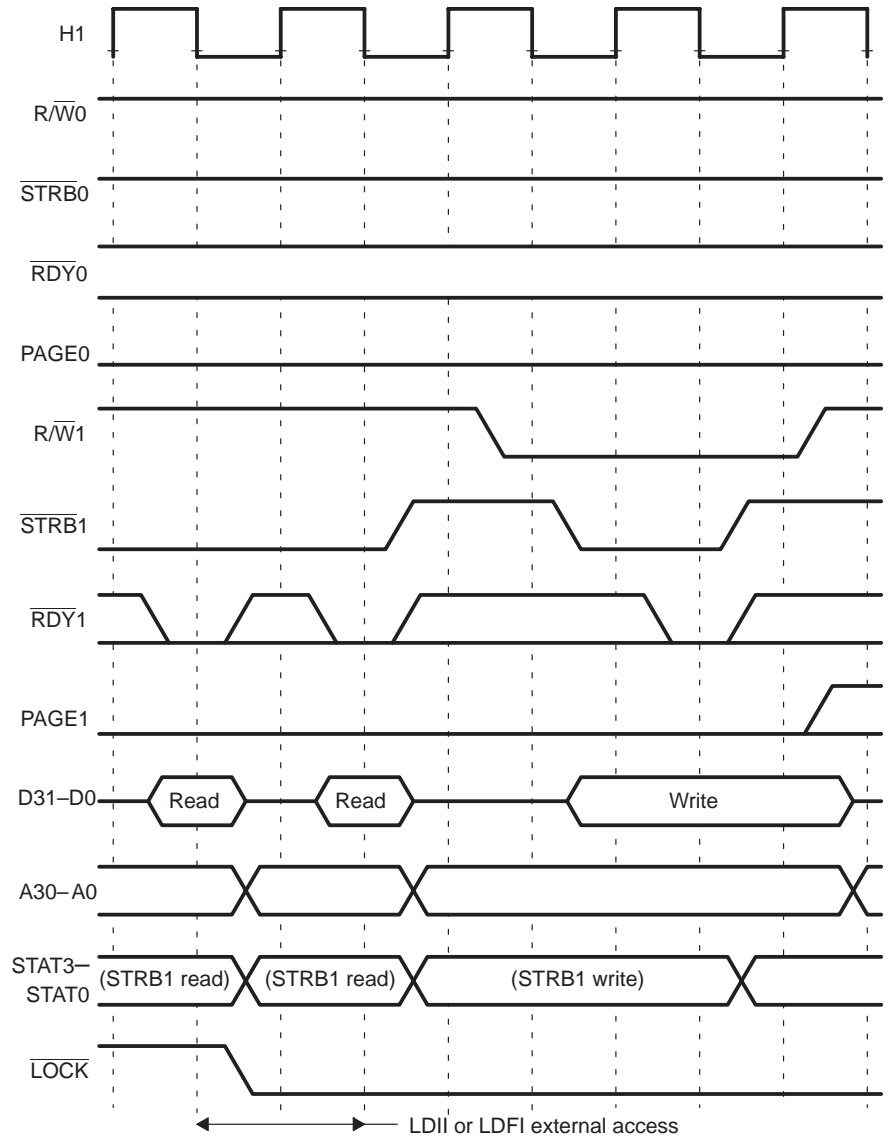

Figure 9–30 is an example of STII or STFI external access following the previous interlocked load (shown in Figure 9–29) and an idle cycle. This is the timing for an interlocked load/interlocked store sequence.

Figure 9–30. LDII or LDFI and STII or STFI External Access

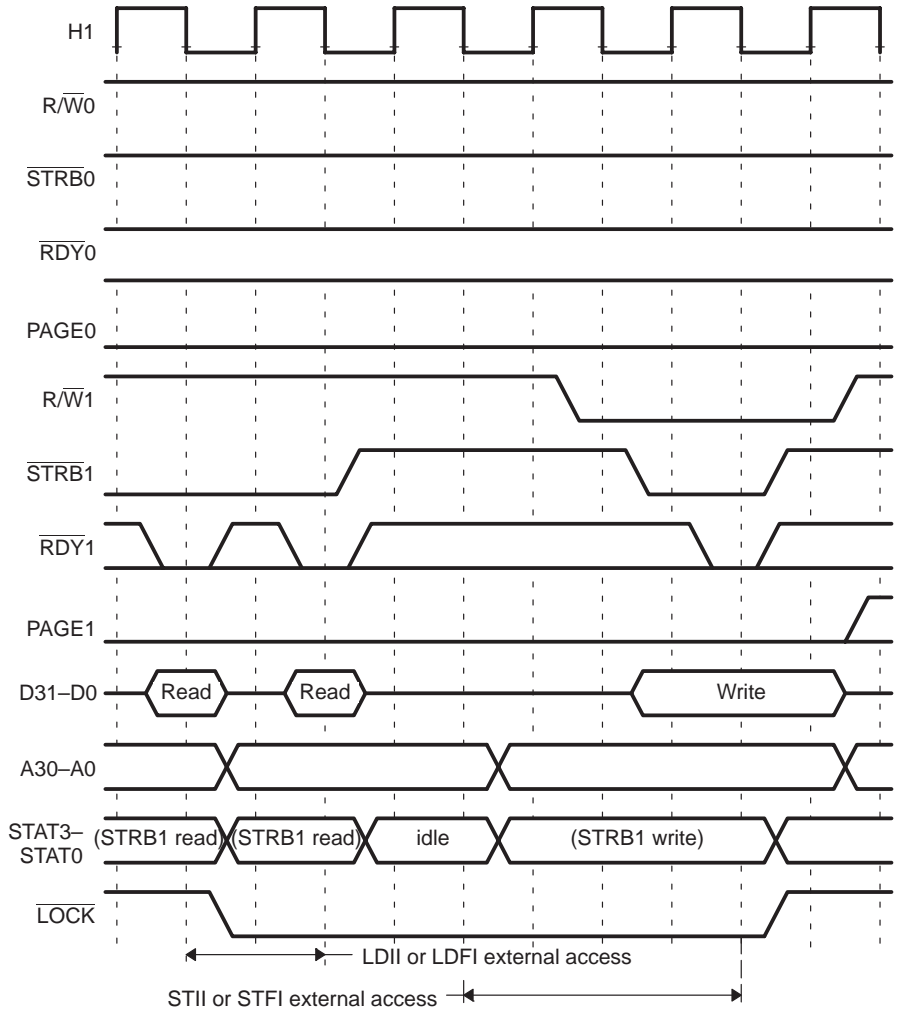

Figure 9–31 is an example of a SIGI external access.

Figure 9–31. SIGI External Access Timing

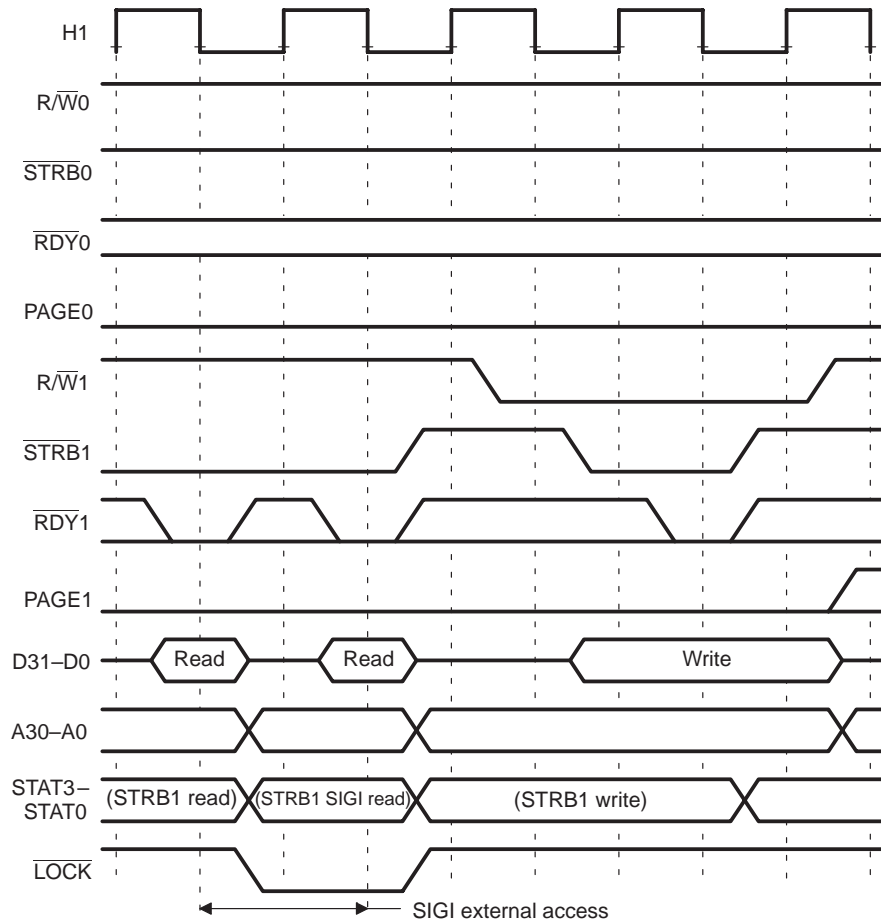
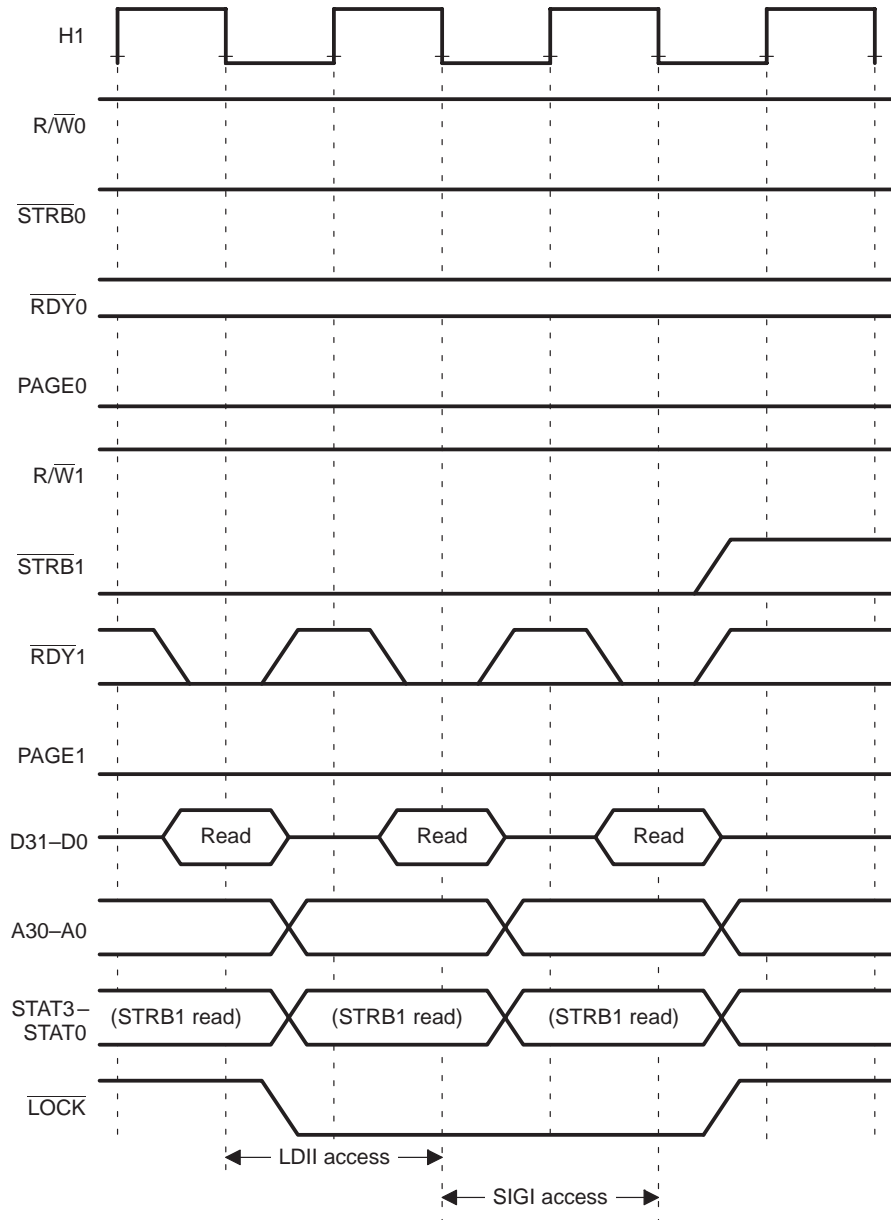

Figure 9–32 illustrates timing for SIGI if the $\overline{\text{LOCK}}$ signal is already low. This could occur when a SIGI follows an LDII instruction. Since $\overline{\text{LOCK}}$ is already low, the only effect SIGI has on $\overline{\text{LOCK}}$ is to bring it high.

Figure 9–32. SIGI When $\overline{\text{LOCK}}$ Is Already Low



9.8 $\overline{\text{IACK}}$ Timing

The $\overline{\text{IACK}}$ pin is affected by the IACK (interrupt acknowledge) instruction. The timing of the pin is similar to that of the $\overline{\text{LOCK}}$ pin when used by the SIGI instruction. In all respects (timing, extension with wait states, etc.) the $\overline{\text{IACK}}$ behaves like a $\overline{\text{LOCK}}$ or STAT signal. The only difference is that there is only one $\overline{\text{IACK}}$ pin.

The timing for the $\overline{\text{IACK}}$ pin is shown in Figure 9–33. Like the interlocked instructions, the IACK instruction affects $\overline{\text{IACK}}$ *only* for an external access.

Figure 9–33. $\overline{\text{IACK}}$ Timing

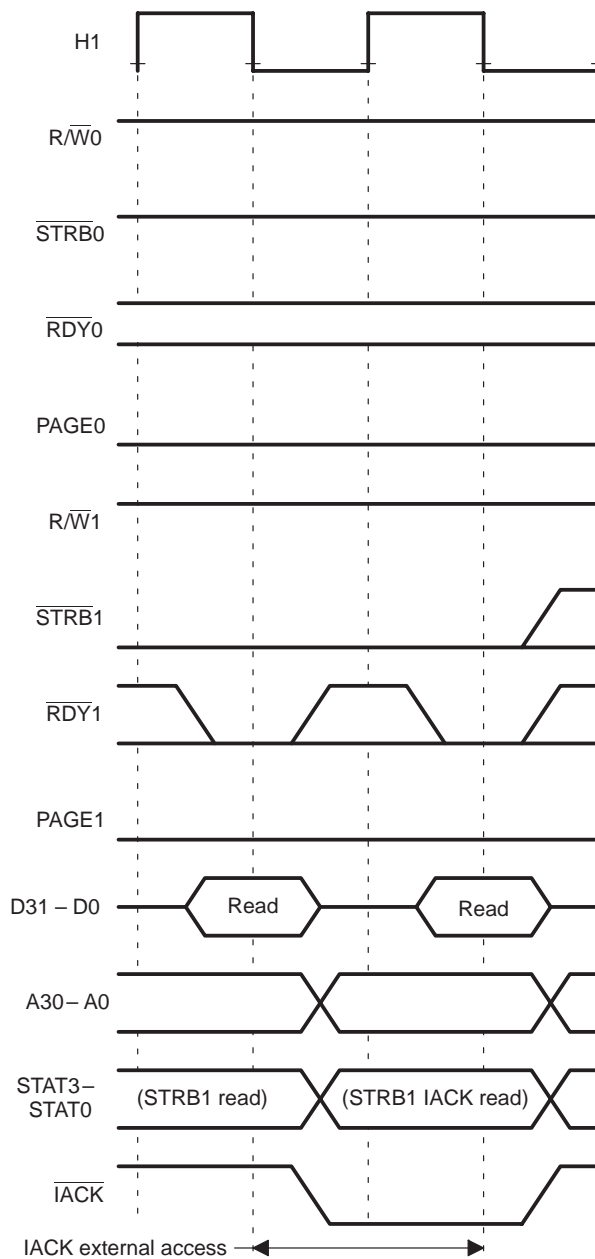

The Bootloader

The bootloader provided in the on-chip ROM of the 'C4x can load and execute source programs that are received from a host processor, an EPROM, or a standard memory device. The 'C4x bootloader functions primarily as either a *memory bootloader* or as a *communication port bootloader*.

Topic	Page
10.1 Bootloader Description	10-2
10.2 Mode Selection	10-3
10.3 Bootloading Sequence	10-5
10.4 Bootloading from External Memory (Examples)	10-10
10.5 Bootloading from a Communication Port (Examples)	10-16
10.6 Modifying the $\overline{\text{IIOFx}}$ Pins After Bootloading	10-19
10.7 The Bootloader Program	10-20

10.1 Bootloader Description

The bootloader code starts at location 0x11bc in the on-chip ROM in both the 'C40 and 'C44. For 'C44 device revisions ≤ 1.0 , the 'C44 bootloader code is identical to the 'C40 bootloader code. For 'C44 device revisions > 1.0 , the 'C44 bootloader code differs in three memory locations from the 'C40 bootloader. These three locations are noted in the code. The bootloader program is listed in Section 10.7, *The Bootloader Program*.

10.2 Mode Selection

The 'C4x bootloader functions primarily as either a *memory bootloader* or a *communication port bootloader*. Bootloader mode selection is determined by the IIOF(3–0) pins, as described in Table 10–1 and shown in Figure 10–1.

- The *memory bootloader* supports user-definable byte, half-word, and full-word data formats, which allow the flexibility to load a source program from memories having widths of 8 bits, 16 bits, or 32 bits. The source programs to be loaded must reside in one of six predefined memory locations, as listed in Table 10–1. $\overline{\text{STRB0}}$ ($\overline{\text{LSTRB0}}$) should be used because they are the active strobes after reset. Figure 10–2 shows the flow for the memory bootloader.
- The *communication port bootloader* waits for the first data input from one of the six ('C40) or four ('C44) communication port channels and uses that channel to perform the bootload. The format of the incoming data stream is similar to that for a memory data stream, except that the source memory width is excluded (the format is described in Table 10–2). Figure 10–3 shows the flow of the communication port bootloader.

Table 10–1. Bootloader Mode Selection Using Pins $\overline{\text{IIOF}}(3–0)$

External Pin				Source Program Location	
$\overline{\text{IIOF}}3$	$\overline{\text{IIOF}}2$	$\overline{\text{IIOF}}1$	$\overline{\text{IIOF}}0$	'C40	'C44
1	1	0	1	0030 0000h	0030 0000h
1	0	1	1	4000 0000h	4000 0000h†
1	0	0	1	6000 0000h	0080 0000h
0	1	1	1	8000 0000h	8000 0000h†
0	1	0	1	A000 0000h	8040 0000h†
0	0	1	1	C000 0000h	8080 0000h†
0	0	0	1	Reserved (the boot-loader terminates)	Reserved (the boot-loader terminates)
1	1	1	1	Communication port	Communication port

† The 'C44 external-address buses each have only the low 24 bits of the internal address bus. Thus, the internal address 4000000h maps to 0h on the local bus. Any address at or above 80000000h is mapped to the global bus; 80800000, for example, maps to address 00800000h on the global bus.

Figure 10–1. Mode Selection Flow

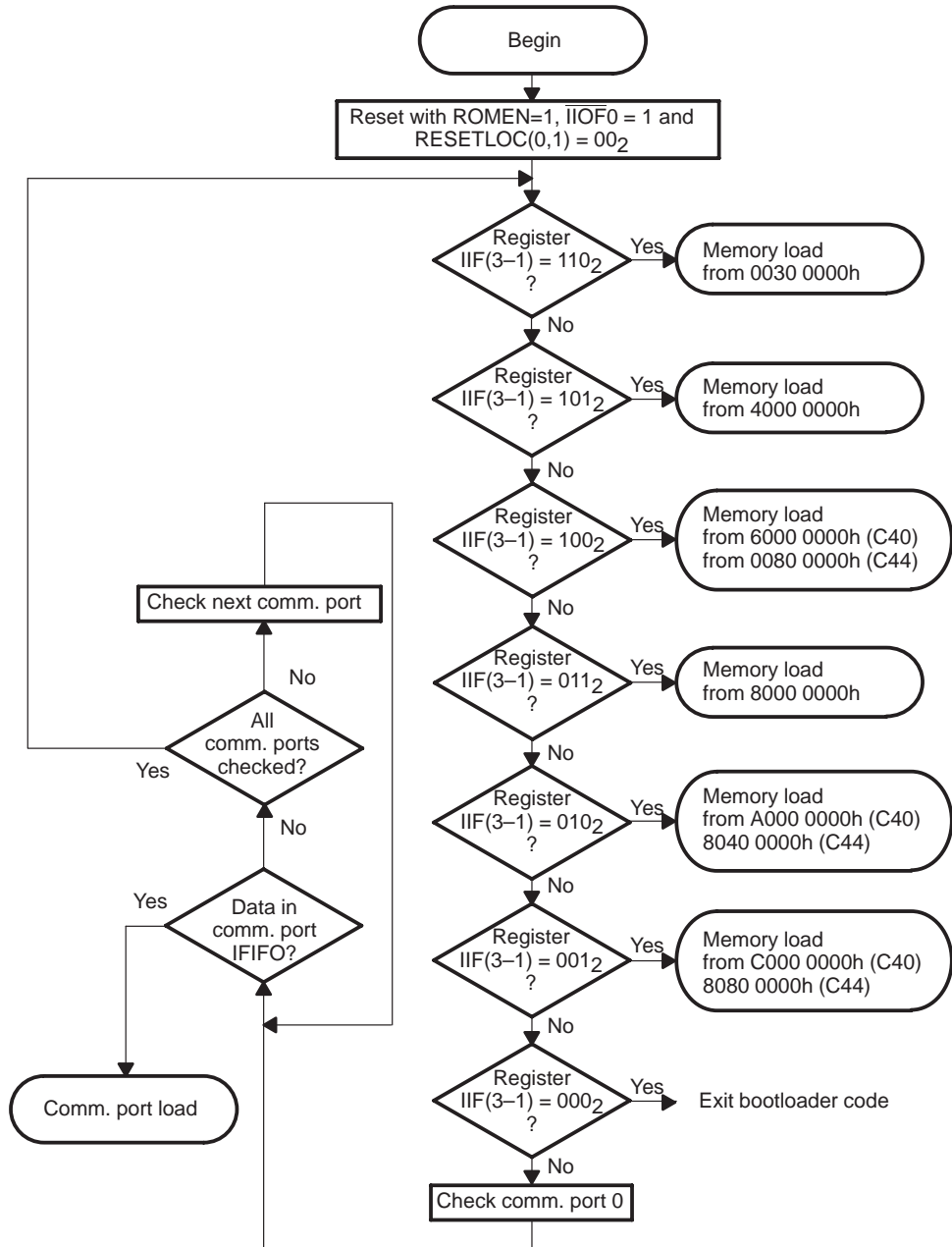

10.3 Bootloading Sequence

Here is the general sequence of events in bootloading a source program:

- 1) Select the bootloader by resetting the 'C4x while driving the RESETLOC(1,0) pins low, the on-chip ROM enable pin (ROMEN) high, and the $\overline{\text{IIOF}}_0$ pin high. The ROMEN pin must be high during bootloader execution, but it can be changed anytime after bootloading.
- 2) The status of external pins $\overline{\text{IIOF}}(3-1)$ indicates where to find the source program to be loaded (memory or communication port). These options are listed in Table 10-1. Pins $\overline{\text{IIOF}}(3-1)$ are read as the IIOF flags in the CPU IIF register. The bootloader takes the following steps to determine the source program's location, as is shown in Figure 10-1.
 - a) If an IIF(3-1) value of from 110_2 to 001_2 (6 to 1) is found, the source program is loaded from the corresponding memory address shown in the top six lines of Table 10-1. See Figure 10-2 for details on bootloader memory flow.
 - b) The IIF(3-1) value of 000_2 (0) is reserved. You should not use this mode.
 - c) If none of the combinations $000_2 - 110_2$ are found, the bootloader program assumes that loading will be via a communication port, and it starts checking communication port input channels (in the order port 0 through port 5). If it finds no inputs from a communication port, the program returns to checking the status of the $\overline{\text{IIOF}}(3-1)$ pins again. See Figure 10-3 for details on bootloader communication port flow.
- 3) When the source program's data stream is found, the program is loaded at the address found in the fifth word of the data stream (the format is shown in Table 10-2), using the bus width specified in the first word (8, 16, or 32 bits wide). *The bootloader cannot load the source program to any location below 0000 1000h, unless the address decode logic is remapped.* The first five words of the source program specify its loading and execution criteria. Remaining words are the source program(s) and vector table pointers as shown in Table 10-2.
- 4) An IACK instruction is executed, indicating the completion of the bootload sequence. This indication can then be used to switch from microcomputer (ROMEN = 1) to microprocessor mode (ROMEN = 0). You do not need to reset the 'C4x to change the ROMEN pin. However, ensure that the 'C4x will not access addresses 0000 0000h to 0000 0FFFh during the change.
- 5) The source program is executed (entry point is the first word of the *first* loaded program).

Figure 10–2. Memory Load Flow

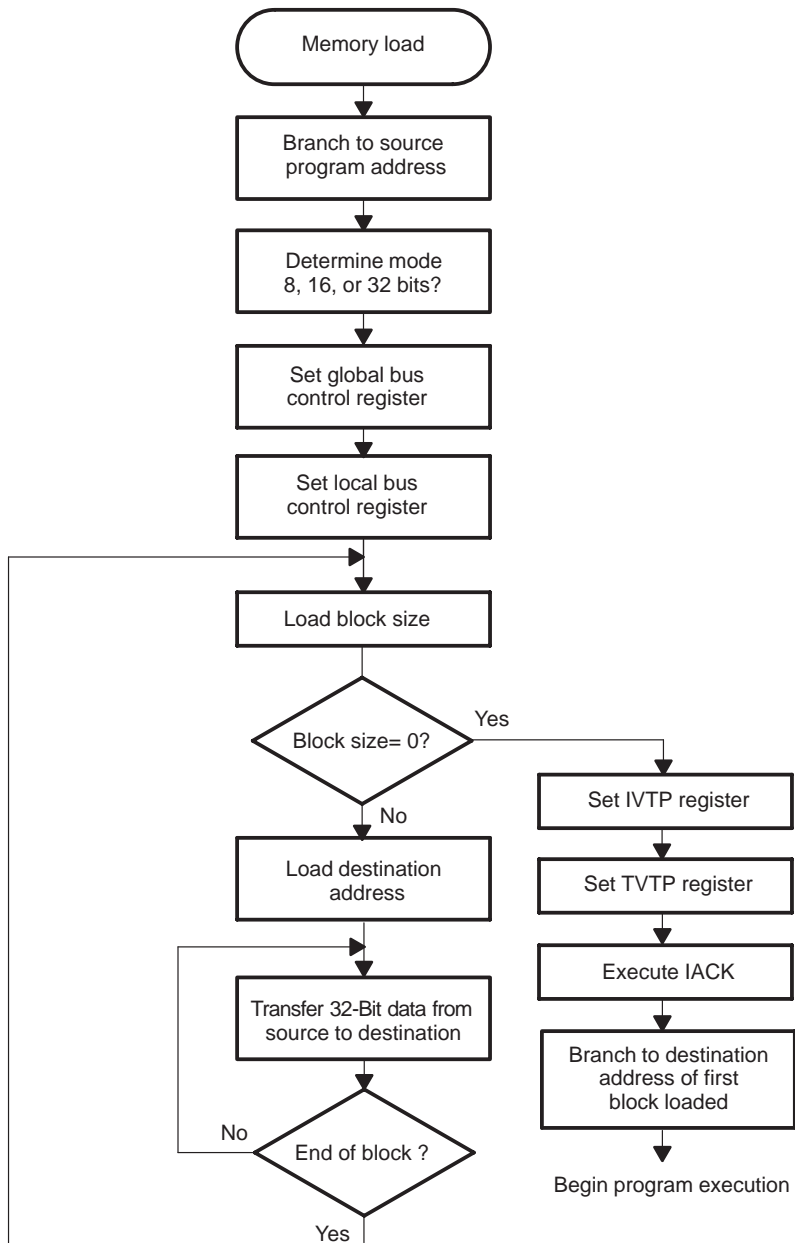
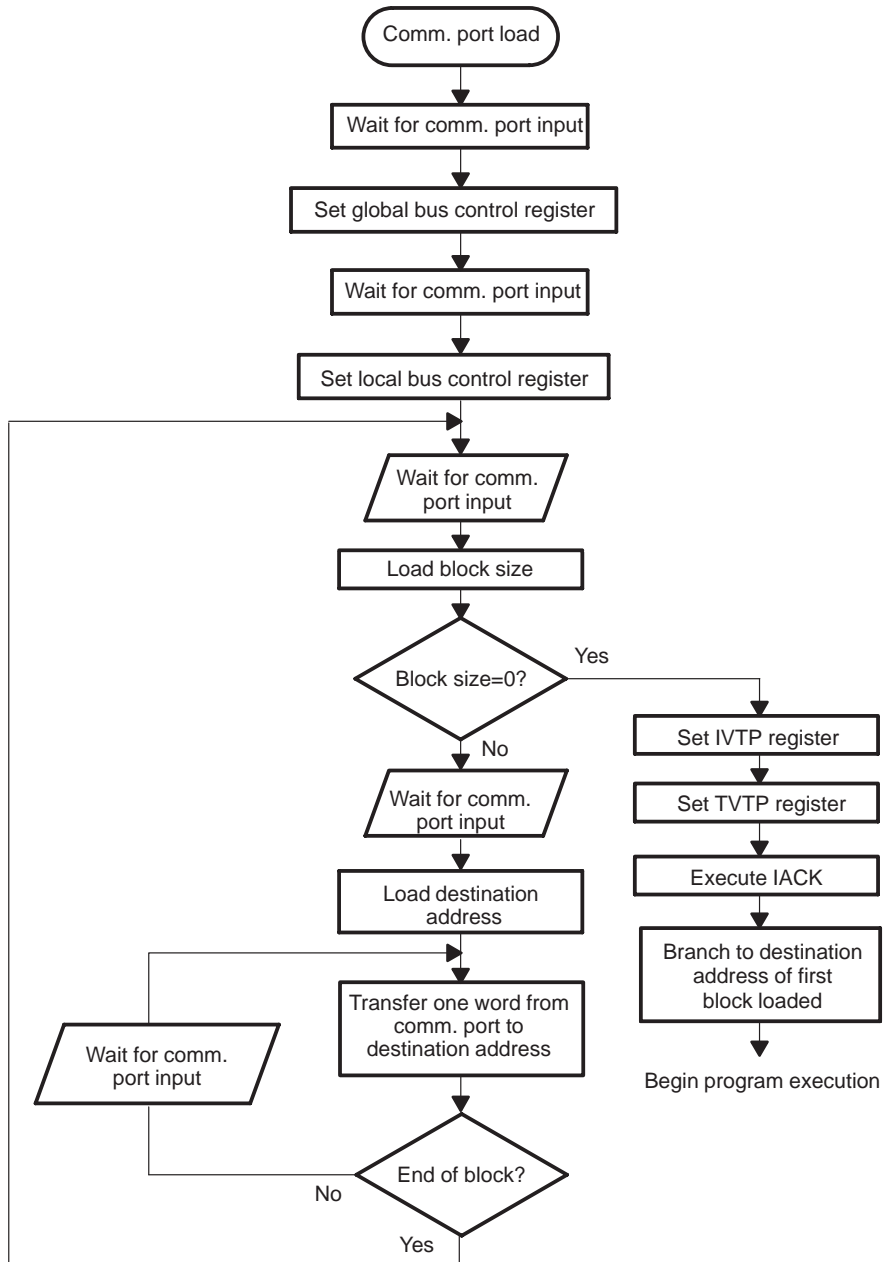

Figure 10–3. Communication-Port Load Mode Flow



The data stream with its source program(s) should be in the format shown in Table 10–2. The contents of words 4 through n vary for the different source programs loaded throughout the entire data stream. The first three words and the last three words are nonvariables that affect each of the source-program blocks. The eight least significant bits (LSBs) of the first word specify the memory width. If byte or half-word wide is selected, the loading sequence is from LSBs to MSBs.

Table 10–2. Structure of Source Program Data Stream

Word	Contents
1	Memory width where source program resides (8, 16, or 32 bits wide)
2	Value to set in the global memory interface control register (shown in Figure 9–2).
3	Value to set in the local memory interface control register (shown in Figure 9–2).
4	Block size in 32-bit words of the first program block to be loaded (after the number of words is loaded, the next word should be all zeros; if not, another block is assumed to follow).
5	Address where the source program is to be loaded.
6	First word of source program.
n	Last word of source program (the program organized as words 4 through n — these shaded words).
$n+1$	Word of all zeros. (Note that if several source-program blocks were sent, word n above would be the last word of the <i>last</i> source-program block. Each source-program block would have the format shown in words 4 through n . This word of all zeros follows the <i>last</i> source program block).
$n+2$	IVTP value (interrupt vector table pointer, see Section 3.2).
$n+3$	TVTP value (trap vector table pointer, see Section 3.2).
$n+4$	Memory location for IACK instruction (see IACK instruction in Chapter 14).

Note: The shaded area identifies the source program block.

Each source program in a multiple block program transfer can be loaded to different specified destinations. Each program block specifies its program's size and destination address at the beginning of the block. End the entire block program loader function by following the last block with an all-zero word (0000 0000h).

The second and third last words of the source memory define the interrupt vector table pointer (IVTP) and the trap vector table pointer (TVTP). The last word of the source memory defines the memory location for the IACK instruction. The IACK instruction brings the $\overline{\text{IACK}}$ signal low as data is read, if the memory location specified in the IACK instruction is in external memory that is available in the system. Finally, the processor begins execution of the first code block.

CAUTION
It is assumed that at least one block of source will be loaded when the bootloader is invoked. Initial loader invocation with a block size of 0000 0000h produces unpredictable results.

10.4 Bootloading from External Memory (Examples)

When the 'C4x's ROMEN input pin is high and RESETLOC(1,0)=00₂ during reset, the memory bootloader can load programs stored in off-chip memory (typically 8-, 16-, or 32-bit ROMs) at an address determined by the $\overline{\text{IIOF}}$ pins to any valid external or internal memory in the 'C4x's memory map.

Because address zero (0) is reserved for the bootloader, address zero should not be used for the reset vector when a user-defined, internal ROM-code mask is used.

The 8 LSBs of the first word of data read stream specify the memory width (8, 16, or 32 bits) as shown in Table 10–3, Table 10–4, and Table 10–5.

- 8-bit memories: 08h
- 16-bit memories: 0010h
- 32-bit memories: 0000 0020h

If 8- or 16-bit external memories are used, the loading sequence is from LSBs to MSBs. The bootloader reads the contents of 16-bit wide memories (least significant half word first) and packs each pair of 16-bit half words to make a 32-bit word before loading each word to memory. Accordingly, the bootloader reads the contents of byte-wide memories (least significant byte first) and packs each group of four bytes into a 32-bit word before loading each word to memory. Because the bootloader packs bytes before loading, no external hardware is needed to pack the loaded bytes into a 32-bit word. For 32-bit wide external memories, no byte packing is necessary, because the memory data width matches that of the 'C4x.

For 16-bit memories, the data read is expected to be in bit positions 0–15. Thus, the half-word memory's data lines should be interfaced to 'C4x data lines (L)D15–0. For byte-wide memories, the data read is expected to be in bit positions 0–7. Hence, the byte-wide memory's data lines should be interfaced to 'C4x data lines (L)D7–0. Even though the 'C4x does not require that unused data lines be pulled up to V_{CC} , it is recommended that each unused data line be pulled up through separate 22 K Ω resistors to 5 volts for minimum power dissipation.

Table 10–3, Table 10–4, and Table 10–5 show example data streams for 8-bit, 16-bit, and 32-bit wide configured memories, respectively.

These examples assume that:

- ❑ The status of the $\overline{\text{IIOF}}(0-3)$ pins is 110_2 after reset is deasserted (memory load from 0030 0000h — see Table 10–1).
- ❑ The source program resides at memory location 0030 0000h and defines the following:
 - Memory width for bootloader: 8, 16, or 32 bits
 - Global bus memory with one software wait state, external RDY (SWW = 11), page size = 64K words for both $\overline{\text{STRB0}}$ and $\overline{\text{STRB1}}$, and an active address range = 1G words for both $\overline{\text{STRB0}}$ and $\overline{\text{STRB1}}$.
 - Local memory bus that requires two software wait states (SWW = 01), page size = 32K words, and active address range = 1G words for both $\overline{\text{STRB0}}$ and $\overline{\text{STRB1}}$.
 - First block program of 294 words in length and whose destination address is at 002F F840h.
 - Second block program of 64 words in length and whose destination address is at 002F F800h.
 - IVTP and TVTP, which are overlapped and point to the beginning of the on-chip RAM.
 - Memory location of 0030 0000h for IACK instruction.

Table 10–3. Byte-Wide Configured Memory

Word	Address	Value	Comments
1	0030 0000h	08h	Memory width = 8 bits
	0030 0001h	00h	
	0030 0002h	00h	
	0030 0003h	00h	
2	0030 0004h	F0h	Global memory bus control word = 1D7B C9F0h (Described in Figure 9–2 on page 9-7)
	0030 0005h	C9h	
	0030 0006h	7Bh	
	0030 0007h	1Dh	

Table 10–3. Byte-Wide Configured Memory (Continued)

Word	Address	Value	Comments
3	0030 0008h	50h	Local memory bus control word = 1D73 9250h
	0030 0009h	92h	(Described in Figure 9–2 on page 9-7)
	0030 000Ah	73h	
	0030 000Bh	1Dh	
4	0030 000Ch	26h	1st source program block size = 126h
	0030 000Dh	01h	
	0030 000Eh	00h	
5	0030 0010h	40h	1st source program block starting addr = 002F F840h
	0030 0011h	F8h	
	0030 0012h	2Fh	
	0030 0013h	00h	
6	0030 0014h		1st source program block starts here (first word)
to	•	•	
299	•	•	
	•	•	
	0030 04ABh		1st source program block ends here (last word)
300	0030 04ACh	40h	2nd source program block size = 40
	0030 04ADh	00h	
	0030 04AEh	00h	
	0030 04AFh	00h	
301	0030 04B0h	00h	2nd source program block starting addr = 002F F800h
	0030 04B1h	F8h	
	0030 04B2h	2Fh	
	0030 04B3h	00h	
302	0030 04B4h		2nd source program block starts here (first word)
to	•	•	
365	•	•	
	•	•	
	0030 05B3h		2nd source program block ends here (last word)

Note: The shaded area identifies the source program block.

Table 10–3. Byte-Wide Configured Memory (Continued)

Word	Address	Value	Comments
366	0030 05B4h	00h	Value 0 to terminate the program block load
	0030 05B5h	00h	
	0030 05B6h	00h	
	0030 05B7h	00h	
367	0030 05B8h	00h	IVTP = 002F F800h
	0030 05B9h	F8h	
	0030 05BAh	2Fh	
	0030 05BBh	00h	
368	0030 05BCh	00h	TVTP = 002F F800h
	0030 05BDh	F8h	
	0030 05BEh	2Fh	
	0030 05BFh	00h	
369	0030 05C0h	00h	Memory location for IACK instruction =0030 0000h
	0030 05C1h	00h	
	0030 05C2h	30h	
	0030 05C3h	00h	

Note: The shaded area identifies the source program block.

Table 10–4. 16-Bit Wide Configured Memory

Word	Address	Value	Comments
1	0030 0000h	0010h	Memory width = 16 bits
	0030 0001h	0000h	
2	0030 0002h	C9F0h	Global memory bus control word = 1D7B C9F0h
	0030 0003h	1D7Bh	
3	0030 0004h	9250h	Local memory bus control word = 1D73 9250h
	0030 0005h	1D73h	
4	0030 0006h	0126h	1st program block size = 126h
	0030 0007h	0000h	
5	0030 0008h	F840h	1st program block starting addr.= 002F F840h
	0030 0009h	002Fh	
6 to 299	0030 000Ah • • • 0030 0255h		1st program block starts here (first word) • • • 1st program block ends here (last word)
300	0030 0256h	0040h	2nd program block size = 40h
	0030 0257h	0000h	
301	0030 0258h	F800h	2nd program block starting addr.= 002F F800h
	0030 0259h	002Fh	
302 to 365	0030 025Ah • • • 0030 02D9h		2nd program block starts here (first word) • • • 2nd program block ends here (last word)
366	0030 02DAh	0000h	Value 0 to terminate the program block load
	0030 02DBh	0000h	
367	0030 02DCh	F800h	IVTP = 002F F800h
	0030 02DDh	002Fh	
368	0030 02DEh	F800h	TVTP = 002F F800h
	0030 02DFh	002Fh	

Note: The shaded area identifies the source program block.

Table 10–4. 16-Bit Wide Configured Memory (Continued)

Word	Address	Value	Comments
369	0030 02E0h	0000h	Memory location for IACK instruction = 0030 0000h
	0030 02E1h	0030h	(This is the final word in the data stream.)

Note: The shaded areas identify the source program blocks.

Table 10–5. 32-Bit Wide Configured Memory

Word	Address	Value	Comments
1	0030 0000h	0000 0020h	Memory width = 32 bits
2	0030 0001h	1D7B C9F0h	Global memory bus control word = 01D7B C9F0h
3	0030 0002h	1D73 9250h	Local memory bus control word = 01D73 9250h
4	0030 0003h	0000 0126h	1st program block size = 126h
5	0030 0004h	002F F840h	1st program block starting addr = 002F F840h
6	0030 0005h		1st program block starts here (first word)
to	•		•
299	•		•
	•		•
	0030 012Ah		1st program block ends here (last word)
300	0030 012Bh	0000 0040h	2nd program block size = 40h
301	0030 012Ch	002F F800h	2nd program block starting addr = 002F F800h
302	0030 012Dh		2nd program block starts here (first word)
to	•		•
365	•		•
	•		•
	0030 016Ch		2nd program block ends here (last word)
366	0030 016Dh	0000 0000h	Value 0 to terminate the program block load
367	0030 016Eh	002F F800h	IVTP = 002F F800h
368	0030 016Fh	002F F800h	TVTP = 002F F800h
369	0030 0170h	0030 0000h	Address location for IACK instruction = 00030 0000h

Note: The shaded areas identify the source program blocks.

10.5 Bootloading from a Communication Port (Examples)

A value of all 1s on $\overline{\text{IIOF}}(0-3)$ signals that the source program is being transmitted via a communication port. Bringing all four of the $\overline{\text{IIOF}}(0-3)$ pins high also allows the pins to be used as interrupt lines without any external decode logic. With pins $\overline{\text{IIOF}}(0-3)$ all high at reset, the 'C4x polls the input level of each port to determine which channel contains the program. The input data sequence of the communication bootloader is the same as that of the memory bootloader except that it lacks the source memory width definition (because the memory width of the communication port bootloader is fixed).

Example 10-1 is a program listing for booting a multiprocessor system.

After a 32-bit boot from external memory, the master 'C4x boots — via a communication port—another 'C4x (slave processor) connected to communication port 0 of the master processor. Both processors stay in an infinite loop after booting. The code should be loaded in the master 'C4x EPROM in the correct memory location according to the $\overline{\text{IIOF}}$ settings of the master 'C4x. All $\overline{\text{IIOF}}$ pins of the slave processor should be set to 1. The ROMEN pin is enabled (ROMEN=1) and the RESETLOC(1,0) pins are low in both processors. For a description of how to convert an executable COFF file into an EPROM programmer format, see the hex conversion utility in the *TMS320 Floating Point Assembly Language Tools User's Guide* (literature number SPRU035).

Example 10–1. Booting a 'C4x Multiprocessor System

```

*-----
*      MASTER PROCESSOR BOOT TABLE
*-----
      .text
      .word    32                ; memory width
      .word    3003c000h         ; MASTER global control register
                                ; (system specific !!)
      .word    3d79c210h        ; master local control register
                                ; (system specific !!)

*-----
*      MASTER PROCESSOR PROGRAM BLOCK
*-----
      .word    10                ; block size
      .word    2ff800h           ; block dest addr

* Code for master processor: this code sends boot table to slave processor
      ldi 8,rc                    ; loop 9 times: size of slave processor
                                ; boot table

      rptbd endb1
      ldp src                      ; src in external memory
      ldi @src,ar0
      ldi @dst,ar1
      ldi *ar0++(1),r0            ; block start
endb1:  sti r0,*ar1
      bu $                        ; master processor loops forever
src     .word BOOT_TABLE2        ; address of boot table of slave
                                ; processor
dst     .word 100042h            ; address of OFIFO connected to slave
                                ; processor

*-----
*      END OF ALL BLOCKS
*-----
      .word    0                ; master end of bootload sequence
      .word    2ffd00h           ; master IVTP value
      .word    2ffd00h           ; master TVTP value
      .word    40000000h         ; master address for iack

*-----
*      END OF MASTER PROCESSOR BOOT TABLE : size = 9 words
*-----

```

Example 10–1. Booting a 'C4x Multiprocessor System (Continued)

```
*-----  
*           SLAVE PROCESSOR BOOT TABLE  
*-----  
BOOT_TABLE2:                ; slave BOOT TABLE  
    .word    3003c000h        ; slave global control register  
                                ; (system specific !!!)  
    .word    3d79c210h        ; slave local control register  
                                ; (system specific !!!)  
    .word    1                ; block size  
    .word    2ff800h          ; dst load address  
    bu      $                ; slave processor loops forever  
    .word    0                ; slave end of bootload sequence  
    .word    2ffd00h          ; slave IVTP value  
    .word    2ffd00h          ; slave TVTP value  
    .word    40000000h        ; slave address for iack  
*-----  
*           END OF EPROM CODE  
*-----
```

10.6 Modifying the IIOF_x Pins After Bootloading

The load options are based upon the status of IIOF₍₃₋₀₎ as general-purpose input pins. Therefore, to select the correct bootloader mode, pins IIOF₍₃₋₀₎ must be kept at a constant valid status value (see Table 10-1 for a list of values).

After the bootload is complete, the IACK signal is brought low until the read phase in the pipeline finishes. Figure 10-4 shows an example circuit that generates the IIOF₍₃₋₀₎ signals for bootload selection and, after bootload operation, allows incoming external interrupts. In this example, after reset, the IIOF pins stay low until the IACK signal is received.

Figure 10-4. Circuit for Generation of a Low IIOF Signal for Bootloader Selection

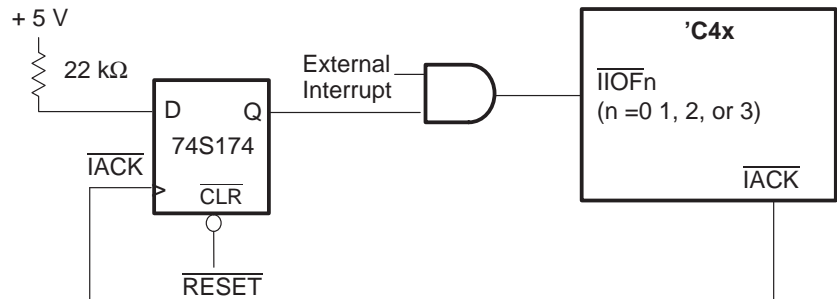

10.7 The Bootloader Program

```
*****
*
* C40BOOT - TMS320C40 BOOTLOADER PROGRAM
* (C) COPYRIGHT TEXAS INSTRUMENTS INC., 1990
*
* NOTE 1. AFTER THE DEVICE IS RESET, THE PROGRAM IS CHECKING THE INPUT STATUS
* OF IIOF0-3 PINS AND COMMUNICATION PORT INPUT FLAGS TO CONFIGURE ITSELF WHEN
* THE ON-CHIP ROM IS ENABLED (ROMEN=1). THE IIOF0 PIN IS ASSUMED TO BE HIGH.
*
* NOTE 2. THE FUNCTION SELECTION OF IIOF0-3 IS LISTED AS:
*
*   IIOF   IIOF   IIOF   IIOF           FUNCTION
*   3     2     1     0
*   1     1     0     1     Memory bootloader from 00300000H
*   1     0     1     1     Memory bootloader from 40000000H
*   1     0     0     1     Memory bootloader from 60000000H
*   0     1     1     1     Memory bootloader from 80000000H
*   0     1     0     1     Memory bootloader from A0000000H
*   0     0     1     1     Memory bootloader from C0000000H
*   0     0     0     1     Reserved
*   1     1     1     1     Communication port bootloader
*
* THE PROGRAM ASSUMES THE COMMUNICATION PORT BOOTLOADER IS THE DEFAULT
* FUNCTION. IF NO OTHER FUNCTION IS SELECTED,THE PROGRAM STARTS CHECKING
* THE COMMUNICATION PORT INPUT CHANNELS. IF THERE IS NO INPUT FROM A
* COMMUNICATION PORT, THE PROGRAM RECHECKS THE IIOF(3-0) STATUS AGAIN.
*
* NOTE 3.MEMORY BOOTLOADER LOADS WORD, HALF-WORD, OR BYTE WIDE PROGRAM TO
* DIFFERENT SPECIFIED LOCATIONS. THE 8 LSBs OF THE FIRST MEMORY SPECIFIES THE
* MEMORY WIDTH. IF THE HALF-WORD OR BYTE WIDE PROGRAM IS SELECTED, THE LSBs
* ARE LOADED FIRST AND THEN THE MSBs. THE NEXT 2 WORDS CONTAIN THE CONTROL
* WORD FOR THE GLOBAL AND LOCAL MEMORY INTERFACE CONTROL REGISTERS. NEXT COME
* THE PROGRAM BLOCKS. THE FIRST TWO WORDS OF EACH PROGRAM BLOCK CONTAIN THE
* BLOCK SIZE AND DESTINATION ADDRESS WHERE THE PROGRAM IS TO BE LOADED. WHEN
* THE ZERO BLOCK SIZE IS READ, THE PROGRAM BLOCK LOADING IS TERMINATED. THE
* NEXT TWO WORDS ARE THE INITIAL VALUES FOR THE IVTP AND TVTP REGISTERS.
* AFTER THE BOOTLOADING IS COMPLETED, THE IACK SIGNAL IS SENT OUT ACCORDING
* TO THE LAST WORD OF THE SOURCE MEMORY, AND THE PROGRAM COUNTER WILL BRANCH
* TO THE STARTING ADDRESS OF THE FIRST PROGRAM BLOCK.
*
* NOTE 4.IF IIOF(3-0) ARE SET FOR COMMUNICATION PORT BOOTLOADER, THE PROCESSOR
* WAITS FOR THE FIRST INPUT FROM AN INPUT COMMUNICATION CHANNEL AND USE THAT
* CHANNEL TO PERFORM THE DOWNLOAD. THE BEGINNING TWO WORDS SHOULD CONTAIN THE
* GLOBAL AND LOCAL BUS CONTROL WORDS. SIMILAR TO THE MEMORY LOADER, THE
* PROGRAM CAN BE LOADED INTO DIFFERENT MEMORY BLOCKS. THE FIRST TWO WORDS OF
* EACH PROGRAM BLOCK CONTAINS THE BLOCK SIZE AND MEMORY ADDRESS TO BE LOADED
* INTO. WHEN THE ZERO BLOCK SIZE IS READ, THE PROGRAM BLOCK LOADING IS
* TERMINATED. IN OTHER WORDS, TO TERMINATE THE PROGRAM BLOCK LOADING, A
* ZERO HAS TO BE ADDED AT THE END OF PROGRAM BLOCK. THE FOLLOWING TWO WORDS
* ARE THE INITIAL VALUES FOR THE IVTP AND TVTP REGISTERS. AFTER THE BOOT-
* LOADING IS COMPLETED, THE IACK SIGNAL IS SENT OUT ACCORDING TO THE LAST
* WORD OF THE SOURCE MEMORY AND THE PROGRAM COUNTER BRANCHES TO THE STARTING
* ADDRESS OF THE FIRST PROGRAM BLOCK.
```

```

.sect "boot"
*****
*                TMS320C4x PROCESSOR BOOTLOADER                *
*****
BOOT:    LDI     COM_LOAD,R10    ; Comm. port load subroutine address -> R10
        LDHI    0010H,AR0       ; Load peripheral mem. map start addr 100000H
*
*    CHECK THE IIOF1-3 FOR THE BOOTLOADER
*
CHECK:   LDHI    0030H,AR1       ; Load memory address = 00300000H
        CMPI    04404H,IIF      ; Test function 110 condition
        BEQ     MEMORY          ; If true, execute memory bootloader
        LDHI    04000H,AR1      ; Load memory address = 40000000H
        CMPI    04044H,IIF      ; Test function 101 condition
        BEQ     MEMORY          ; If true, execute memory bootloader
        ;
        LDHI    06000H,AR1      ; Load memory address = 60000000H
        ; 'C44: LDHI 00080h,AR1; replace previous line with this line ('C44)
        ;
        CMPI    04004H,IIF      ; Test function 100 condition
        BEQ     MEMORY          ; If true, execute memory bootloader
        LDHI    08000H,AR1      ; Load memory address = 80000000H
        CMPI    00444H,IIF      ; Test function 011 condition
        BEQ     MEMORY          ; If true, execute memory bootloader
        ;
        LDHI    0A000H,AR1      ; Load memory address = A0000000H
        ; 'C44: LDHI 08040,AR1; replace previous line with this line ('C44)
        ;
        CMPI    00404H,IIF      ; Test function 010 condition
        BEQ     MEMORY          ; If true, execute memory bootloader
        ;
        LDHI    0C000H,AR1      ; Load memory address = C0000000H
        ; 'C44: LDHI 08080H; replace previous line with this line ('C44)
        ;
        CMPI    00044H,IIF      ; Test function 001 condition
        BEQ     MEMORY          ; If true, execute memory bootloader
        CMPI    00004H,IIF      ; Test function 000 condition
        BEQ     STATRAM         ; If true, branch to STATIC RAM TEST
*-----
*                COMMUNICATION PORT BOOTLOADER
*-----
*
*    CHECK COMMUNICATION PORT INPUT CHANNEL
*
        ADDI    040H,AR0,AR3    ; Point to comm. port 0 control register addr
        LDI     5,AR1           ; Set loop counter for CHECK_CH loop
CHECK_CH: LSH3    -9,*AR3,R1     ; Check comm port input
        BNZ    LOAD0           ; If input exist, start comm port loader
        ADDI    010H,AR3       ; Point to next comm. port channel addr
        DBU    AR1,CHECK_CH    ; Check next comm. port channel input
        B      CHECK           ; Recheck the input flags

```

```

*-----
*
*                               MEMORY BOOTLOADER
*-----
*
*   TEST MEMORY WORD WIDTH
*
MEMORY:   LDI    *AR1++(1),R1    ; Load the memory word width
          LDI    W_WIDE,R10     ; Full-word size subroutine address -> R10
          LSH    26,R1          ; Test bit5 of mem. width word
          BN     LOAD0          ; If '1' start PGM loading (32 bits width)

          NOP    *AR1++(1)     ; Jump last half word from mem. word
          LDI    H_WIDE,R10     ; Half-word size subroutine address -> R10
          LSH    1,R1           ; Test bit4 of mem. width word
          BN     LOAD0          ; If '1' start PGM loading (16 bits width)

          NOP    *AR1++(1)     ; Jump last 1 bytes from mem. word
          LDI    B_WIDE,R10     ; Byte size subroutine address -> R10
          NOP    *AR1++(1)     ; Jump last 1 bytes from mem. word

*
*   START PROGRAM LOADING
*
LOAD0:    LAJU   R10             ; Load new word according to mem. width
          LDHI   0010H,AR0       ; Load peripheral mem. map start addr 100000H
          LDI    1,R0            ; Set start address flag off
          NOP
          LAJU   R10             ; Load new word according to mem. width
          STI    AR2,*AR0        ; Set global bus control register
          NOP
          NOP
          STI    AR2,*+AR0(4)    ; Set local bus control register

LOAD2:    LAJU   R10             ; Load new word according to mem. width
          ADDI   1,R0            ; Set start address flag off
          NOP
          NOP
          CMPI   0,AR2          ; If 0 block size start PGM
          BEQ    IVTP_LOAD

          LAJU   R10             ; Load new word according to mem. width
          SUBI3  1,AR2,RC        ; Set block size for repeat loop
          NOP
          SUBI   1,R10           ; Sub address with loop
          LDI    R0,R0           ; Test start address loaded flag
          LDIP   AR2,R9          ; Load start address if flag off
          LAJU   R10             ; Load block words according to mem. width
          LDI    AR2,AR0         ; Set destination address
          LDI    -1,R0           ; Set start & dest. address flag on
          ADDI   1,R10           ; Sub address without loop
          B      LOAD2           ; Jump to load a new block when loop completed

```

```

*
*   INITIALIZE IVTP AND TVTP REGISTERS
*
IVTP_LOAD: LAJU    R10           ; Load new word according to mem. width
            NOP
            NOP
            NOP
TVTP_LOAD: LAJU    R10           ; Load new word according to mem. width
            LDPE    AR2,IVTP     ; Load the IVTP pointer
            NOP
            NOP
            LAJU    R10           ; Load new word according to mem. width
            LDPE    AR2,TVTP     ; Load the TVTP pointer
            NOP
            NOP
            IACK    *AR2         ; Send out IACK signal out
            BU      R9           ; Branch to the start of the program
;-----;
;   BYTE-WIDE MEMORY BOOTLOADER SUBROUTINE   ;
;-----;
LOOP_B:    RPTB    LOAD_B        ; PGM load loop
B_WIDE:    LWL0    *AR1++(1),AR2 ; Load byte 0 (LSB)
            NOP                ; Nop for STRB to go high
            LWL1    *AR1++(1),AR2 ; Join byte 1 with byte 0
            NOP                ; Nop for STRB to go high
            LWL2    *AR1++(1),AR2 ; Join byte 2 with byte 0 & 1
            NOP                ; Nop for STRB to go high
            LWL3    *AR1++(1),AR2 ; Join byte 3 with byte 0, 1, & 2
            LDI     R0,R0        ; Test load address flag
            BNN     B_END
LOAD_B:    STI     AR2,*AR0++(1) ; Store new word to dest. address
B_END:     BU      R11          ; Return from subroutine
;-----;
;   HALF-WORD WIDE MEMORY BOOTLOADER SUBROUTINE   ;
;-----;
LOOP_H:    RPTB    LOAD_H        ; PGM load loop
H_WIDE:    LWL0    *AR1++(1),AR2 ; Load LSB half-word
            NOP                ; Nop for STRB to go high
            LWL2    *AR1++(1),AR2 ; Join MSB half-word with LSB half-word
            LDI     R0,R0        ; Test load address flag
            BNN     H_END
LOAD_H:    STI     AR2,*AR0++(1) ; Store new word to dest. address
H_END:     BU      R11          ; Return from subroutine
;-----;
;   FULL-WORD WIDE MEMORY BOOTLOADER SUBROUTINE   ;
;-----;
LOOP_W:    RPTB    LOAD_W        ; PGM load loop
W_WIDE:    LDI     *AR1++(1),AR2 ; Read a new 32 bits word
            LDI     R0,R0        ; Test load address flag
            BNN     W_END
LOAD_W:    STI     AR2,*AR0++(1) ; Store new word to dest. address
W_END:     BU      R11          ; Return from subroutine

```

```
;-----;
;          COMMUNICATION PORT BOOTLOADER SUBROUTINE          ;
;-----;
LOOP_C      RPTB      LOAD_C          ; PGM load loop
COM_LOAD    LSH3      -9,*AR3,R1      ; Check comm port input
            BZ        COM_LOAD        ; Wait for comm port input
            LDI       *+AR3(1),AR2    ; Read a new 32 bits word
            LDI       R0,R0           ; Test load address flag
            BNN      C_END
LOAD_C      STI       AR2,*AR0++(1)   ; Store new word to dest. address
C_END       BU        R11             ; Return from subroutine
            .end
```

The DMA Coprocessor

The direct memory access (DMA) coprocessor is a programmable on-chip device that allows simultaneous memory transfer and CPU operation with minimum CPU overhead. This chapter describes the DMA coprocessor and also offers suggestions for programming the device.

Topic	Page
11.1 Introduction	11-2
11.2 DMA Functional Description	11-3
11.3 DMA Registers	11-7
11.4 DMA Unified Mode	11-19
11.5 DMA Split Mode	11-20
11.6 DMA Internal Priority Schemes	11-22
11.7 CPU and DMA Coprocessor Arbitration	11-27
11.8 Data Transfer Modes	11-28
11.9 Autoinitialization	11-34
11.10 DMA and Interrupts	11-42
11.11 DMA Memory Transfer Timing	11-51

11.1 Introduction

The DMA coprocessor is a self programmable peripheral that transfers blocks of data by maximizing sustained CPU performance and by alleviating the CPU of burdensome I/O duties.

- ❑ Transfers to and from anywhere in the processor's memory map. For example, transfers can be made to and from on-chip memory, off-chip memory, and any of the six on-chip communication ports.
- ❑ Six DMA channels for memory-to-memory transfers in unified mode; a special split mode supports 12 DMA channels for communication port to/from memory transfers.
- ❑ Automatic initialization of registers via linked lists stored in memory, allowing the DMA to run continuously without intervention by the CPU.
- ❑ Concurrent CPU and DMA coprocessor operation with DMA transfers at the same rate as the CPU (supported by separate internal DMA address and data buses)
- ❑ Source and destination address registers with variable indices, making it possible to step through matrices by row or column
- ❑ Bit-reversed addressing for FFTs
- ❑ Synchronization of data transfers via external and internal interrupts

11.2 DMA Functional Description

The DMA coprocessor supports six DMA channels that perform transfers to and from anywhere in the 'C4x memory map.

Each DMA channel is controlled by nine registers that are mapped in the 'C4x peripheral address space, as shown in Figure 11–1. The major DMA registers are described in Section 11.3.

The DMA coprocessor has dedicated on-chip address and data buses (see Figure 2–8 for a block diagram of the peripherals of the 'C4x). All accesses made by the six DMA channels are arbitrated in the DMA coprocessor and take place over these dedicated buses. The six DMA channels transfer data in a sequential time-slice fashion, rather than simultaneously, because they share common buses.

The DMA channels can run constantly or can be triggered by external ($\overline{\text{IIOF3}}\text{--}0$) or internal (on-chip timers and communication ports) interrupts.

The DMA coprocessor can transfer data in a bit-reversed fashion (for FFT applications) or in a linear fashion; it can also transfer matrix data in a row or column fashion.

The DMA coprocessor has two basic operational modes:

- **Unified Mode:** Used for memory-to-memory transfers. The unified mode is described in Section 11.4, *DMA Unified Mode*. The unified block transfer sequence is presented in subsection 11.2.1, *Block Transfer Sequence*.
- **Split Mode:** Used for two-way, memory-to-communication port transfers. The split mode is described in Section 11.5, *DMA Split Mode*.

Figure 11–1. DMA Coprocessor Memory Map

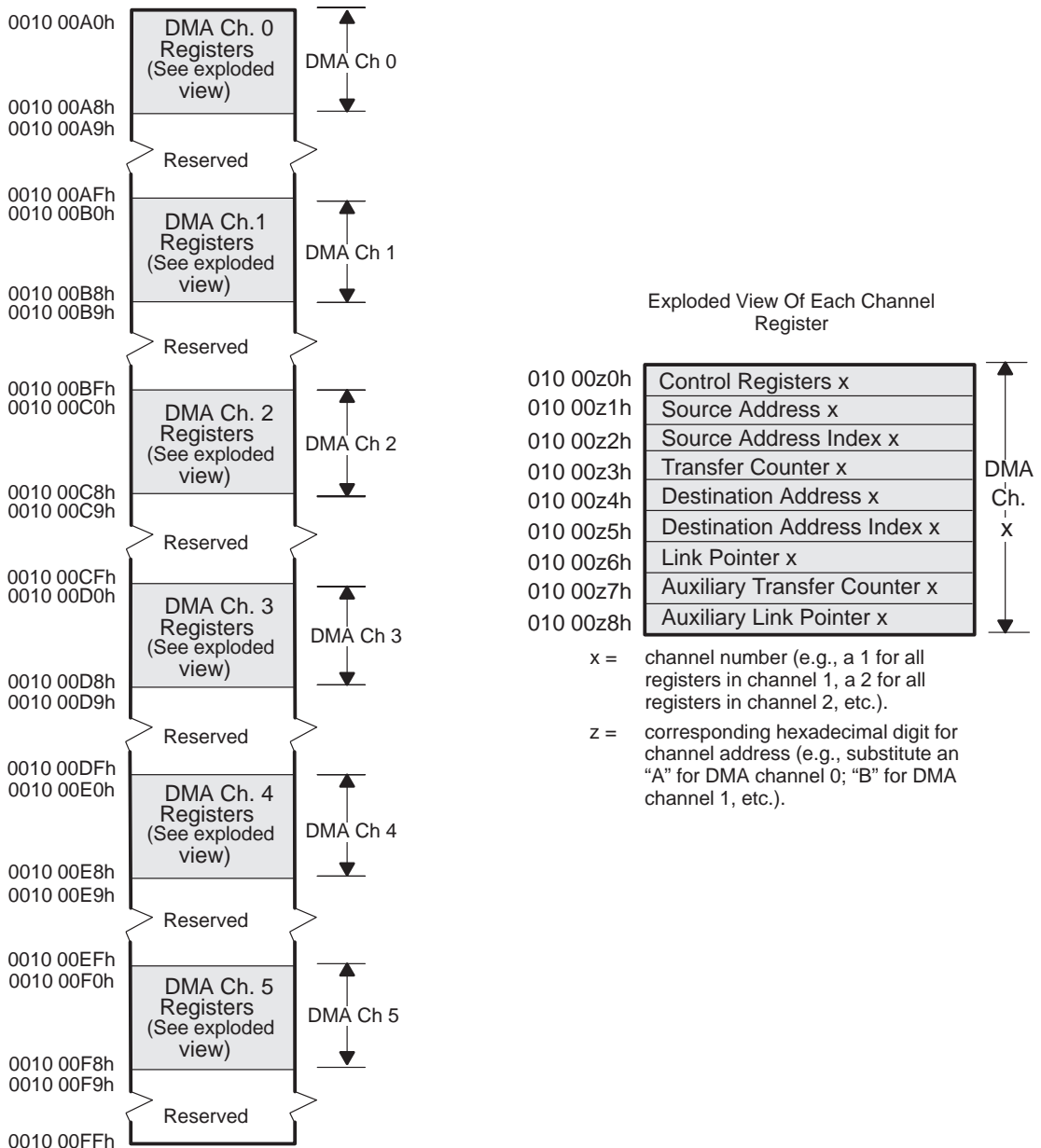

11.2.1 DMA Basic Operation

If a block of data is to be transferred from one region in memory to another region in memory (unified mode), the following sequence is performed:

DMA Registers Initialization

- 1) The source address register of a DMA channel is loaded with the address of the memory location to read from.
- 2) The destination address register of the same DMA channel is loaded with the address of the memory location to write to.
- 3) The transfer counter is loaded with the number of words to be transferred.
- 4) The source/destination index register is loaded with the step size of source/destination register update. If sequential memory accesses are required, the source address index register and the destination address index register must be set to 1.
- 5) The DMA channel control register is loaded with the appropriate modes to synchronize the DMA coprocessor reads and writes with interrupts. The DIE register determines which interrupt to use for synchronous transfer.

DMA Start

- 6) The DMA coprocessor is started via the DMA START field in the DMA channel control register.

Word Transfers

- 7) The DMA channel reads a word from the source address register and writes it to a temporary register within the DMA channel.
- 8) After a read by the DMA channel, the source-index register is added to the source address register.
- 9) After the read operation completes, the DMA channel writes the temporary register value to the destination address pointed to by the destination address register.
- 10) After the destination address has been fetched, the transfer counter register is decremented and the destination-index register is added to the destination-address register.

Note:

Both of the index registers (source and destination) contain signed values. This allows for variable step sizes or continuous reads from and/or writes to memory. When an index register equals zero, the DMA coprocessor transfers data to or from a fixed location.

- 11) During every data write, the transfer counter is decremented. The block transfer terminates when the transfer counter reaches zero *and* the write of the last transfer is completed. The DMA channel sets the transfer counter interrupt (TCINT) flag in the DMA channel control register.

After the completion of a block transfer, the DMA coprocessor can be programmed to do several things:

- Stop until reprogrammed (TRANSFER MODE bits = 01_2)
- Continue transferring data (TRANSFER MODE bits = 00_2)
- Generate an interrupt to signal the CPU that the block transfer is complete (TCC bit = 1_2)
- Autoinitialize itself to start the next block transfer (TRANSFER MODE bits = 10_2 or 11_2).

Each DMA channel reads new DMA register values from memory, loads these values into its register file, and, according to the values loaded, begins another block transfer. Whether or not the CPU must initialize transfers is determined by the value of the transfer mode bits:

- Autoinitialization under transfer mode bits = 10_2 is done without any intervention by the CPU.
- Autoinitialization under transfer mode bits = 11_2 requires the CPU to start the DMA.

11.3 DMA Registers

Each DMA channel has nine registers designated as follows:

- Control register:** contains the status and mode information about the associated DMA channel.
- Source address register:** contains the memory address of data to be read.
- Source address-index register:** contains the step size (a signed 32-bit number) used to increment or decrement the source address register.
- Destination address register:** contains the memory address where data is written.
- Destination address-index register:** contains the step size (a signed 32-bit number) used to increment or decrement the destination address register.
- Transfer counter register:** contains the block size to move in unified mode or in split mode (primary channel).
- Auxiliary transfer-counter register:** contains the block size to move in split mode (auxiliary channel).
- Link pointer register:** contains the memory address of data to autoinitialize the DMA channel registers. Used for unified mode or primary channel in split mode.
- Auxiliary link-pointer register:** contains the memory address of data to autoinitialize the DMA channel registers. Used for auxiliary channel in split mode.

After reset, the control register, the transfer counter, and the auxiliary transfer counter registers are set to zeros and the other registers are undefined.

11.3.1 Control Register

The format of the DMA-channel control register is shown in Figure 11–2. The text following the figure describes the functions of each field in the register.

At reset, each DMA-channel control register is set to zero. This makes the DMA channels lower-priority than the CPU, sets up the source address and destination address to be calculated via linear addressing, and configures the DMA channel in the unified mode.

Figure 11–2. DMA Channel Control Register

31	30	29	28	27	26	25	24	23	22	21	20	19	18
xx	PRIORITY MODE	AUX STATUS	STATUS	AUX START	START	AUX TCINT FLAG	TCINT FLAG	AUX TCC	TCC				
	RW	R	R	RW-A	RW	R	R	RWSA	RWS				
			17	16	15	14	13	12	11	10			
			COM PORT			SPLIT MODE	WRITE BIT REV	READ BIT REV	AUX AUTOINIT SYNC	AUTOINIT SYNC			
			RW-A	RW-A	RW-A	RWSA	RWSA	RWS	RWSA	RWS			
			9	8	7	6	5	4	3	2	1	0	
			AUX AUTOINIT STATIC	AUTOINIT STATIC	SYNC MODE	AUX TRANSFER MODE	TRANSFER MODE	DMA PRI					
			RWSA	RWS	RWSA	RWS	RWSA	RWSA	RWS	RWS	RWS	RWS	

R – Bit may be read.

W – Bit may be written.

S – Bit is shadowed during autoinitialization (no changes take place until autoinitialization is complete.)

A – Bit is auxiliary for autoinitialization.

xx – Reserved.

 DMA Channel 0 only

DMA PRI Sets DMA coprocessor priority. Defines the arbitration rules to be used when a DMA channel and the CPU are requesting the same resource. Affects all DMA coprocessor modes. The rules are listed in Table 11–1.

TRANSFER MODE Defines the transfer mode used by the DMA channel. Affects unified mode and the primary channel in split mode. The bits are defined in Table 11–2.

AUX TRANSFER MODE Defines the transfer mode used by the DMA channel. Affects the *auxiliary* channel in split mode only. The bits are defined in Table 11–2.

SYNC MODE Determines the mode of synchronization for performing data transfers. These bits work differently in unified and split modes. See Table 11–3 and Table 11–4 for bit descriptions for unified and split modes.

Note: If a DMA channel is interrupt driven for both reads and writes, *and* the interrupt for the write comes before the interrupt for the read, the interrupt for the write is latched by the DMA channel. After the read is complete, the write can be executed.

AUTOINIT STATIC This bit affects unified mode and the primary channel in split mode. It keeps the auxiliary link pointer constant during autoinitialization from the on-chip communication ports or other stream-oriented devices (such as first-in first-out (FIFO) memory buffers). *If bit=0*, the link pointer is incremented during autoinitialization. *If bit=1*, the link pointer is *not* incremented (it is static) during autoinitialization.

AUX AUTOINIT STATIC	Acts like the AUTOINIT STATIC bit above, except that it affects the auxiliary channel in split mode only.
AUTOINIT SYNC	This bit has an effect only in the DMA coprocessor sync mode (bits 6–7 above). It affects the interrupt that is enabled by the DMA interrupt enable register (shown in Figure 11–25) used for DMA reads: <i>If bit = 0</i> , the interrupt is ignored, and the autoinitialization reads are not synchronized with any interrupt signals. <i>If bit = 1</i> , then the interrupt is recognized and is also used to synchronize the autoinitialization reads. This affects the unified mode and the primary channel in split mode (see the SPLIT MODE bit). The effect of this bit and the SYNC MODE bit in autoinitialization is summarized in Table 11–9.
AUX AUTOINIT SYNC	Acts the same as the AUTOINIT SYNC bit above, except that it affects the auxiliary channel in split mode. The effect of this bit and the SYNC MODE bits in autoinitialization is summarized in Table 11–9.
READ BIT REV	Selects type of addressing for modifying the source address. <i>If bit=0</i> , the source address is modified using 32-bit linear addressing. <i>If bit = 1</i> , the source address is modified using 24-bit bit-reversed addressing. The bit affects unified mode and primary channel reads (source) in split mode.
WRITE BIT REV	Selects the type of addressing for modifying the destination address. <i>If bit = 0</i> , the destination address is modified using 32-bit linear addressing. <i>If bit=1</i> , the destination address is modified using 24-bit bit-reversed addressing. The bit affects unified mode and auxiliary channel writes (destination) in split mode.
SPLIT MODE	This bit controls the DMA coprocessor mode of operation. <i>If bit = 0</i> , DMA transfers are from memory to memory. This is referred to as <i>unified mode</i> . <i>If bit = 1</i> , <i>split mode</i> is entered with each DMA channel split into two channels, allowing a single DMA channel to perform memory-to-communication-port and communication-port-to-memory transfers. The split mode can be modified by autoinitialization in unified mode or by autoinitialization by the auxiliary channel in split mode. Split mode is further described in Section 11.4, <i>DMA Split Mode</i> .
COM PORT	These bits define a communication port (000_2 to 101_2) to be used for DMA transfers. <i>If SPLIT MODE = 0</i> , COM PORT has no effect on the operation of the DMA channel. <i>If SPLIT MODE = 1</i> , COM PORT defines which of the six communication ports to use with the DMA channel. The COM PORT may be modified by autoinitialization in unified mode or by autoinitialization by the auxiliary channel in split mode.

- TCC** Transfer counter interrupt control. If $TCC = 1$, a DMA channel interrupt pulse is sent to the CPU after the transfer counter makes a transition to zero and the write of the last transfer is complete.
- If enabled, the corresponding DMA interrupt (DMA INT0–INT5) occurs at the vector shown in Figure 7–2. If $TCC = 0$, a DMA channel interrupt pulse is not sent to the CPU when the transfer counter transitions to zero. This bit affects unified mode and the primary channel in split mode.
- AUX TCC** Auxiliary transfer counter interrupt control. If $bit = 1$, a DMA channel interrupt pulse is sent to the CPU after the auxiliary transfer counter makes a transition to zero and the write of the last transfer is complete. If enabled, the corresponding DMA interrupt (DMA INT0–INT5) occurs as shown in Figure 7–2. If $bit = 0$, a DMA channel interrupt pulse is not sent to the CPU when the auxiliary transfer counter transitions to zero. This bit affects the auxiliary channel in split mode only.
- TCINT FLAG** Transfer counter interrupt flag. This flag is set to 1 whenever the transfer counter makes a transition to zero and the write of the last transfer is completed. Whenever the DMA channel control register is read, this flag is cleared, *unless* the flag is being set by the DMA in the same cycle as the read. The TCINT FLAG is affected by the unified mode and the primary channel in split mode.
- AUX TCINT FLAG** Auxiliary transfer counter interrupt flag. This flag is set to 1 whenever the auxiliary transfer counter makes a transition to zero and the write of the last transfer is completed. Whenever the DMA control register is read, this flag is cleared, *unless* the flag is being set by the DMA coprocessor in the same cycle as the read. The AUX TCINT FLAG is affected by the auxiliary channel in split mode. Since only one interrupt is available for a DMA channel, you can determine what event had set the interrupt by examining the TCINT FLAG and the AUX TCINT FLAG.
- START** Starts and stops the DMA channel in several different ways (as are listed in Table 11–5). START affects the unified mode and the primary channel in split mode. If they is used to hold a channel in the middle of an autoinit sequence, the START and AUX START bits will hold the autoinit sequence. If the START or AUX START bits are being modified by the DMA channel (for example, to force a halt code of 10_2 on a transfer-counter terminated block transfer) and a write is being performed by an external source to the DMA channel control register, internal modification of the START or AUX START bits by the DMA channel has priority. See TRANSFER MODE bits value of 01_2 in Table 11–2 for more information.
- AUX START** Starts and stops the DMA channel in several different ways (as are listed in Table 11–5). AUX START affects the auxiliary channel in split mode only.

- STATUS** Indicates the status of the DMA channel as listed in Table 11–6. STATUS is updated in the unified mode and by the primary channel in the split mode. Updates are performed every cycle. The STATUS and AUX STATUS bits also determine if the DMA channel has halted or has been reset after writing to the START or AUX START bits.
- AUX STATUS** Indicates the status of the DMA channel as listed in Table 11–6. STATUS is updated by the auxiliary channel in split mode only. Updates are performed every cycle.
- PRIORITY MODE** Priority mode of DMA channel access: *If bit = 0*, priority rotates as shown in Section 11.6. *If bit = 1* priority is fixed as shown in Section 11.6. This bit is available only at DMA channel zero.

Table 11–1. DMA PRI Bits and CPU/DMA Arbitration Rules

DMA PRI Bit Nos: 1 – 0	Description
0 0	DMA coprocessor access is <i>lower</i> priority than CPU access. If the DMA channel and the CPU are requesting the same resource, then the CPU will proceed. These bits are set this way at reset.
0 1	This setting selects <i>rotating arbitration</i> , which sets priorities between the CPU and DMA channel by alternating their accesses, but not exactly equally. Priority rotates between CPU and DMA accesses when they conflict during consecutive instruction cycles. The first time the DMA channel and the CPU request the same resource, the CPU has priority. If, in the following instruction cycle, the DMA coprocessor and the CPU again request the same resource, the DMA has priority. Alternate access continues as long as the CPU and DMA requests conflict in consecutive instruction cycles. When there is no conflict in a previous instruction cycle, the CPU has priority.
1 0	Reserved.
1 1	DMA coprocessor access is <i>higher</i> priority than CPU access. If the DMA channel and the CPU are requesting the same resource, then the DMA will proceed.

Table 11–2. TRANSFER MODE (AUX TRANSFER MODE) Field Descriptions

TRANSFER MODE Bit Nos: 3 – 2 / (5 – 4)	Description
0 0	Transfers are <i>not</i> terminated by the transfer counter, and <i>no</i> autoinitialization is performed. TCINT (transfer counter interrupt) and AUX TCINT can still be used to cause an interrupt when the transfer counter makes a transition to zero. The DMA channel continues to run. Note that the address continues to increment while the transfer count rolls over to its maximum value of 0FFFF FFFFh.
0 1	Transfers are terminated by the transfer counter. No autoinitialization is performed. A halt code of 10 ₂ is placed in the START (or AUX START) field when transfers are completed.
1 0	Autoinitialization is performed when the transfer counter goes to zero without waiting for CPU intervention.
1 1	The DMA channel is autoinitialized when the CPU restarts the DMA coprocessor by using the DMA register in the CPU. When the transfer counter goes to zero, operation is halted until the CPU starts the DMA coprocessor by using the START (AUX START) field in the DMA channel control register (bits 22–23 and 24–25, Table 11–5). A halt code of 10 ₂ is placed in the START (or AUX START) field by the DMA coprocessor.

Table 11–3. SYNC MODE Field Descriptions in Unified Mode

SYNC MODE Bit Nos: 7 – 6	Description
0 0	No synchronization. Interrupts are ignored, see Figure 11–27.
0 1	Source synchronization. A read is not performed until an enabled interrupt occurs (see Figure 11–28a). The interrupt is specified by the DMAx READ field of the DMA interrupt enable (DIE) register (see subsection 11.10.1, <i>Interrupts and Synchronization of DMA Channels</i> , for more information).
1 0	Destination synchronization. A write is not performed until an enabled interrupt occurs (see Figure 11–29a). The interrupt is specified by the DMAx WRITE field of the DMA interrupt enable (DIE) register (subsection 11.10.1, <i>Interrupts and Synchronization of DMA Channels</i> , for more information).
1 1	Source and destination synchronization. A read is performed when an enabled interrupt (specified by the DMAx READ field) occurs. Then, a write is performed when an enabled interrupt (specified by the DMAx WRITE field) occurs (as shown in Figure 11–30). These fields are part of the DMA interrupt enable (DIE) register (see subsection 11.10.1, <i>Interrupts and Synchronization of DMA Channels</i> , for more information).

Table 11–4. SYNC MODE Field Descriptions in Split Mode

SYNC MODE Bit Nos: 7 – 6	Description
0 0	No synchronization. Interrupts are ignored see Figure 11–27.
0 1	Destination synchronization. A primary channel write to the communication-port output FIFO is not performed until an enabled interrupt occurs (see Figure 11–29b). The interrupt is specified by the DMAx PRIMARY WRITE field of the DMA interrupt enable (DIE) register (see subsection 11.10.1, <i>Interrupts and Synchronization of DMA Channels</i> , for more information).
1 0	Source synchronization. An auxiliary-channel read from the communication-port input FIFO is not performed until an enabled interrupt occurs (see Figure 11–28b). The interrupt is specified by the DMAx AUXILIARY READ field of the DMA interrupt enable (DIE) register (see subsection 11.10.1, <i>Interrupts and Synchronization of DMA Channels</i> , for more information).
1 1	Source and destination synchronization. A read from the communication-port input FIFO is performed when an enabled interrupt (specified by the DMAx AUXILIARY READ field) occurs. A write to the communication port output FIFO is performed when an enabled interrupt (specified by the DMAx PRIMARY WRITE field) occurs. These fields are part of the DMA interrupt enable (DIE) register (see subsection 11.10.1, <i>Interrupts and Synchronization of DMA Channels</i> , for more information).

Table 11–5. START (AUX START) Field Descriptions

START (AUX START)	
Bit Nos: 23 – 22 (25 – 24)	Description
0 0	DMA channel reset. DMA-channel read or write cycles in progress are completed (not aborted); any data read is ignored. Any pending (not started) read or write is canceled. The auxiliary (AUX START = 00 ₂) and primary (START = 00 ₂) transfer counters are set to zero. The DMA channel is reset so that when it starts, a new transaction begins; that is, a read is performed. In this mode, stopping is immediate with no other registers loaded.
0 1	DMA halt on read or write boundary. Halts the DMA channel on the first available read or write boundary. If a read or write has begun, the read or write is completed before stopping. If a read or write has not begun, no read or write is started. In this mode, stopping is immediate with no other registers loaded.
1 0	DMA halt on transfer boundary. Halts the DMA channel on the first available transfer boundary. If a DMA transfer has begun, the entire transfer is completed, including both cycles (both read and write operations), before stopping. If a transfer has not begun, none is started. In this mode, stopping is immediate with no other registers loaded. This is also the value after a DMA transfer completes.
1 1	DMA start. Writing 11 ₂ to this field starts the DMA process using the values in the channel's DMA channel registers (Figure 11–1). If the DMA is in autoinitialization, all DMA registers are loaded before starting the operation. The DMA coprocessor starts from reset if previously reset (START or AUX START bits = 00 ₂) or restarts from the previous state if previously halted (START or AUX START bits = 01 ₂ or 10 ₂).

Table 11–6. STATUS (AUX STATUS) Field Descriptions

STATUS (AUX STATUS)	
Bit Nos: 27 – 26 (29 – 28)	Description
0 0	The DMA channel is held on the boundary of the DMA transfer (the write is complete, and the read has not begun). This is the value at RESET after a halt on a transfer boundary or after a block transfer.
0 1	The DMA channel is being held in the middle of a DMA transfer; (the read is complete, and the write has not begun). This occurs only if the START (or AUX START) field = 01 ₂ .
1 0	Reserved.
1 1	The DMA channel is not being held or reset.

11.3.2 Address and Index Registers

As shown in Figure 11–3, both the DMA coprocessor source-address and destination-address registers have an associated index register. After each DMA-channel read (source address) or write (destination address), the corresponding (source or destination) address generator adds the index register to the address register *and places the result in the address register*. In this way, the address register acts as an accumulator because it retains its own sum and the sum of its index register, as is shown by the following equation:

Address Register + Index Register → Address Register

The values in these registers are undefined at reset.

Depending upon bits 12 and 13 (READ BIT REV and WRITE BIT REV) of the DMA channel control register, the addition may be either:

- Linear** (normal addition): READ BIT REV = 0 or WRITE BIT REV = 0, or
- Bit reversed** (reverse carry propagation): READ BIT REV = 1 or WRITE BIT REV = 1.

Both index values (source or destination) are *signed* values.

Figure 11–3. DMA Coprocessor Address Generation

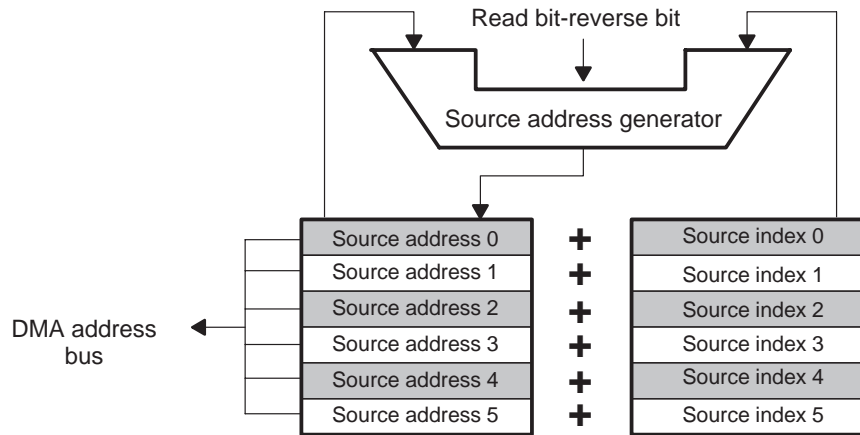

(a) Source address register operation

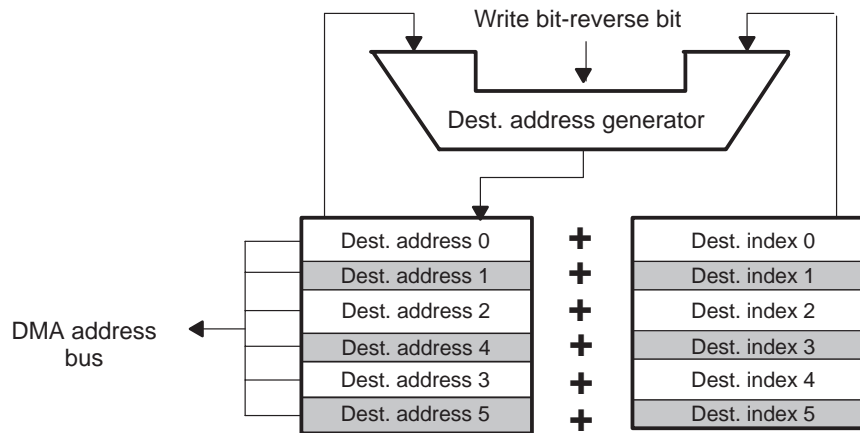

(b) Destination address register operation

11.3.3 Transfer Counter and Auxiliary Transfer Counter Registers

These registers contain the number of words to be transmitted.

Figure 11–4 shows the six transfer counters and the six auxiliary transfer counters. A DMA channel in split mode (described in Section 11.4, *DMA Split Mode*) uses the auxiliary transfer counter for the auxiliary channel and the primary transfer counter for the primary channel. The values in these registers are set to zero at reset.

The counters are decremented after completing the address fetch for the write portion of a transfer. The TCINT FLAG and AUX TCINT FLAG (bits 20 and 21

of the DMA channel control register, as shown in Figure 11–2) are not set *until* the counter is decremented and the write of the last transfer is completed. Correspondingly, the interrupt will not be seen by the CPU interrupt controller until the transfer counter is decremented and the write of the last transfer is completed.

The decrementer checks whether the transfer counter equals zero after the decrement is performed. As a result, if the counter register has a value of 1, then the DMA channel can be halted after only one transfer is performed. Thus, by setting the transfer counter to 1, the DMA channel transfers the minimum possible number of words (1 time). The count is treated as an unsigned integer. Transfers can be halted when a zero count is detected after a decrement. If the DMA coprocessor channel is not halted after the transfer reaches zero, the counter will continue decrementing below zero. Thus, by setting the transfer counter to zero, the DMA channel transfers the maximum possible number of words (10000 0000h times).

Figure 11–4. Transfer Counter Registers

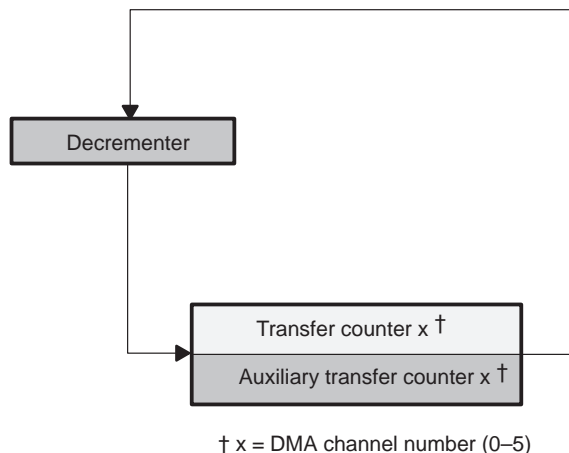

11.3.4 Link Pointer and Auxiliary Link-Pointer Registers

The link pointers specify the address from which to load the new DMA channel register values when autoinitialization is performed. When a channel has exhausted its counter (transfer counter = 0), it will (if appropriately configured) use the link pointer to reload itself. Figure 11–5 illustrates the DMA coprocessor link address registers. The values in these registers are undefined at reset.

For example, under autoinitialization, the steps to load the channel registers for DMA channel 0 (as shown in Figure 11–1) are:

- 1) Get the link pointer for the next DMA operation. The pointer is the memory address containing the contents of the first DMA channel 0 register (the channel control register as shown in Figure 11–1).
- 2) Bring in the contents pointed to by the pointer and write to address 0010 00A0h (first word of DMA channel 0 registers as shown in Figure 11–1).
- 3) Increment the link pointer. (Skip this step if the AUTOINIT STATIC bit = 1.)
- 4) Bring in the next word and write to address 0010 00A1h.
- 5) Repeat until the entire block of registers is loaded for DMA channel 0 (7 registers in unified mode; 5 registers in split mode).

Figure 11–5. Link Pointer Registers

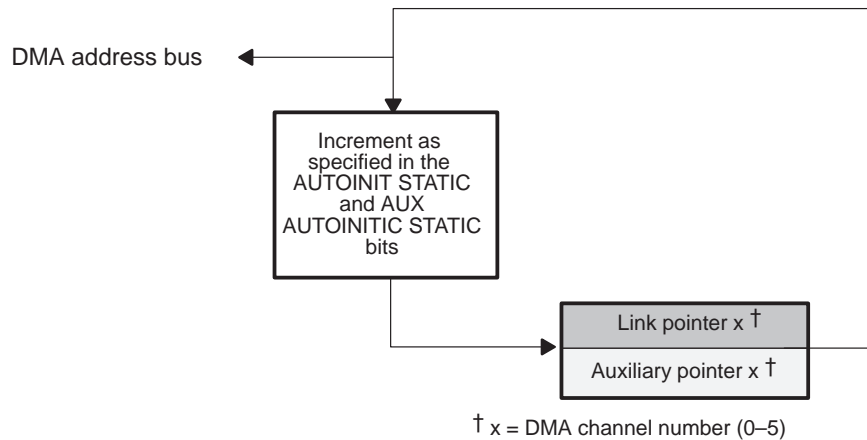

11.4 DMA Unified Mode

Unified mode is the default DMA operational mode. It is used for memory-to-memory transfers. To select unified mode, clear the SPLIT MODE bit (bit 14 of the DMA channel control register, which is shown in Figure 11–2). Thus, write a zero to this bit (zero is the reset value of this bit).

The block transfer sequence under unified mode is covered in subsection 11.2.1. DMA channel arbitration in unified mode is described in Section 11.6. DMA synchronization with interrupts is covered in Section 11.10, *DMA and Interrupts*. Autoinitialization in unified mode is covered in subsection 11.9.1, *Unified Mode*.

A unified DMA word transfer consists of two steps, as shown in Figure 11–6:

- 1) The DMA channel reads the source data value from the address pointed to by the source address register and stores it in a temporary register.
- 2) The DMA channel reads the temporary register value and writes it to the address pointed to by the destination address register.

You can use unified mode to perform communication port transfers, especially unidirectional transfers. Using split mode is more advantageous in bidirectional transfers.

Figure 11–6. Typical Unified-Mode DMA Channel Configuration

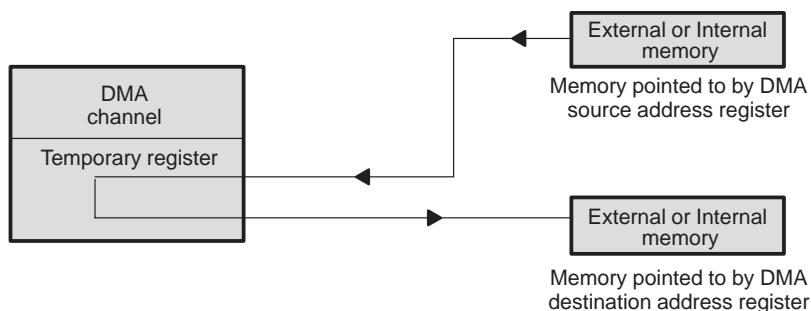

11.5 DMA Split Mode

The DMA split mode (see Figure 11–7) allows one DMA channel to be used for both reading and writing data to a communications port. Split mode essentially transforms one DMA channel into two DMA channels:

- ❑ **Primary Channel:** dedicated to reading data from a location in the memory map (external/internal) and writing it to a communication port output FIFO.
- ❑ **Auxiliary Channel:** dedicated to receiving data from a communication port input FIFO and writing it to a location in the memory map.

To select split mode, set the SPLIT MODE bit (bit 14 of the DMA channel control register, Figure 11–2) to one.

All six DMA channels support this split mode to accommodate all of the communication ports. The COM PORT field (bits 15–17 as shown in Figure 11–2) of the DMA channel control register defines which communication port is used (port 0–5). A DMA channel in split mode can be used with any communication port; however, read/write synchronization is restricted to signals from the communication port with the same number as the DMA channel being used; in other words, DMA *i* can synchronize only with signals coming from communication port *i* (see Section 11.10, *DMA and Interrupts*, for more information). Figure 11–7 shows typical split mode operation with one communication port.

A split mode word transfer is similar to that of the unified mode except for the following differences:

- ❑ The primary channel reads a word from the address pointed to by the source address register and writes it to a temporary register within the DMA coprocessor. It then writes the temporary register value to the output FIFO on the communication port specified in the COM PORT field. The registers that control the primary channel are the DMA channel control register, source address register, source index register (added to source address register), transfer-counter register, and link pointer register.
- ❑ The auxiliary channel reads a word from the input FIFO on the communication port specified in the COM PORT field and writes it to a temporary register within the DMA coprocessor. It then writes the temporary register value in the address pointed to by the destination address register. The registers that control the auxiliary channel are the DMA channel control register, destination address register, destination index register (added to the destination address register), auxiliary transfer-counter register, and auxiliary link pointer register.

DMA channel arbitration in split mode is described in subsection 11.6.3, *Split Mode and DMA Channel Arbitration*. DMA synchronization with interrupts is covered in Section 11.10, *DMA and Interrupts*. Autoinitialization in split mode is covered in subsection 11.9.2, *Split Mode*.

Figure 11–7. Typical Split-Mode DMA Configuration

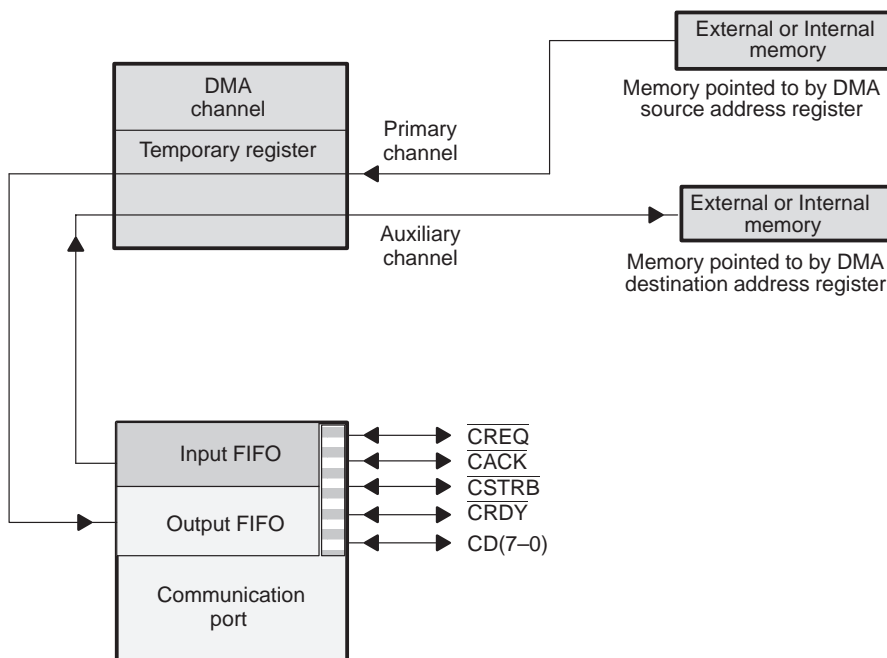

Notice that there is only one temporary register in each DMA channel. Therefore, a primary channel operation must complete before an auxiliary channel operation can begin, and vice versa.

Primary and auxiliary channels share some of the DMA channel control registers and exclusively use others:

- ❑ PRIORITY MODE, COM PORT, SPLIT MODE, and DMA PRI are fields that both primary and auxiliary channels use.
- ❑ AUX STATUS, AUX START, AUX TCINT flag, AUX TCC, WRITE BIT REV, SYNC MODE (bit 7), and AUX TRANSFER MODE are used exclusively by the auxiliary channel.
- ❑ STATUS, START, TCINT flag, TCC, READ BIT REV, SYNC MODE (bit 6), and TRANSFER MODE are used exclusively by the primary channel.

11.6 DMA Internal Priority Schemes

Because all accesses made by the six DMA channels take place over one common internal DMA data and address bus, a priority scheme for bus arbitration is required. Within the DMA coprocessor, two priority schemes are used to designate which channel is serviced next:

- A fixed priority scheme with channel 0 always having the highest priority and channel 5 the lowest.
- A rotating priority scheme that places the most recently serviced channel at the bottom of the priority list (default setup after reset).

11.6.1 Fixed Priority Scheme

This scheme provides a fixed (unchanging) priority for each channel as follows:

Highest priority	0
	1
	2
	3
	4
Lowest priority	5

To select fixed priority, set the PRIORITY MODE bit (bit 30) of channel 0's DMA-channel control register to 1 (one).

11.6.2 Rotating Priority Scheme

In a rotating priority scheme, the last channel serviced becomes the lowest priority channel. The other channels sequentially rotate through the priority list with the lowest channel next to the last-serviced channel becoming the highest priority on the following request. The priority rotates every time the channel most recently granted priority completes its access. Figure 11–8 and Figure 11–10 illustrate the rotation of priority across several DMA coprocessor accesses. At system reset, the channels are ordered from highest to lowest priority (0, 1, 2, 3, 4, 5).

To select this scheme, set the PRIORITY MODE bit (bit 30) of **channel 0's** DMA control register to 0 (zero).

Figure 11–8. Rotating Priority Mode Example of the DMA Coprocessor

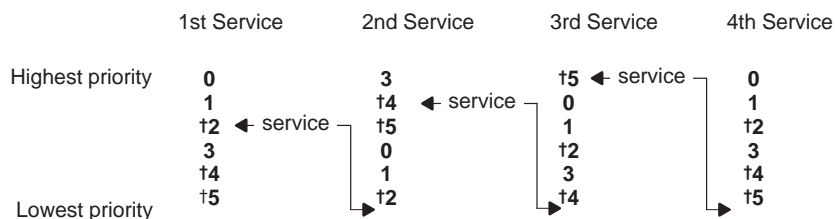

† DMA channel requesting an access

Each service is one read access or one write access. See Figure 11–9 for an example of a read/write sequence.

At the start of the example in Figure 11–8, channels 2, 4, and 5 are requesting service. Because channel 2 has the highest priority, it is serviced first. It then becomes the lowest priority channel. The highest priority channel then becomes channel three. On the following services, channels 4 and 5 are taken care of in a similar fashion. Figure 11–9 shows the entire read and write sequence.

Note:

Each service means one read access or one write access. The DMA coprocessor handles channel arbitration on an access-by-access basis; that is, a DMA channel must contend for both the read and the write access in both unified and split modes.

Figure 11–9. Rotating Priority DMA Read and Write Sequence Example (Unified Mode)

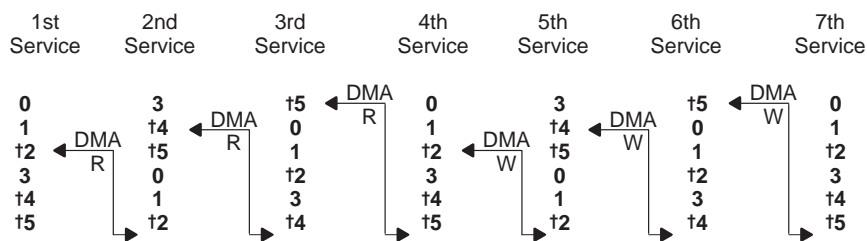

† DMA channel requesting an access

Figure 11–10 shows the same results in a different way as in Figure 11–8 in a rotating priority scheme. Priority decreases from highest to lowest in a clockwise direction. The priority rotates in a counter clockwise direction with the most recently serviced channel becoming the lowest in priority.

Figure 11–10. Example of a Priority Wheel

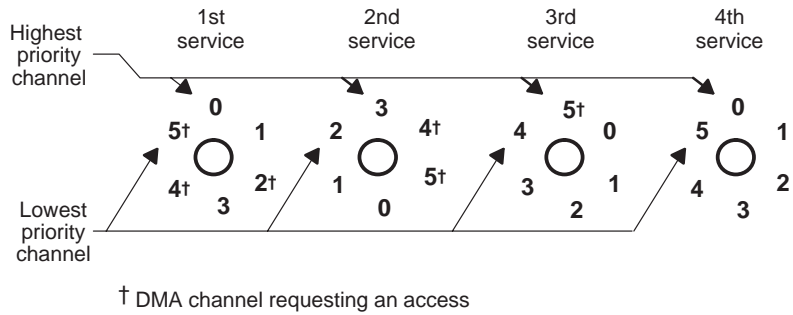

With the rotating priority scheme, any DMA channel requesting service is guaranteed to be recognized after a number of higher priority requests have been serviced. The maximum number of requests are:

- Five in unified mode
- Eleven in split mode

This provides a way of preventing a channel from monopolizing the system.

DMA channels that are running and are not synchronized via interrupts are always requesting service.

11.6.3 Split Mode and DMA Channel Arbitration

When a DMA channel is running in split mode, arbitration between channels is similar to rotating priorities. A split-mode DMA channel has the same priority as a unified DMA channel. The only issue is how to arbitrate between the primary split channel and the auxiliary split channel. The split channels alternate priorities via a rotating priority scheme.

When a DMA channel is in split mode and both paths are simultaneously started via the START and AUX START bits, the output (primary) channel has priority over the input (auxiliary) channel. Both the START and AUX START bits must be written at the same time in order to achieve this reset condition.

The priority scheme for split mode channels is slightly different from the scheme for unified mode channels:

- ❑ For unified channels, the priority changes after a read or a write.
- ❑ For the primary and auxiliary channels within a split channel, priority changes after a complete read and write. This is because there is only one temporary register for both DMA channels (primary and auxiliary) to store the read value.

Figure 11–11 shows two channels contending for the DMA bus: channel 2 (a split channel) and channel 4.

Figure 11–11. Example of a Channel Priority Scheme in Split Mode

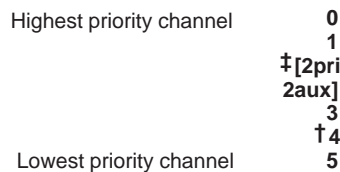

† DMA channel requesting an access

‡ Split channels requesting access

2pri = the primary split channel of channel 2

2aux = the auxiliary split channel of channel 2

The channel priority scheme in Figure 11–11 is shown sequentially in Figure 11–12. In words, the scheme follows eight steps:

- 1) The first service is a request by the primary split channel of channel 2 (2pri). 2pri reads, and then channel 2 is moved to the lowest priority level, but 2pri remains the higher priority channel of channel 2.
- 2) On the second service, channel 4, now a higher priority than channel 2, reads its source address and becomes the lowest priority.
- 3) On the third service, the value read by 2pri is written to its destination address, and channel 2 is moved to the lowest priority level. Also, 2pri is moved to a lower priority than 2aux. Note that the split channel that just completed a read retains a higher priority than the other split channel until the data is written to the destination address.
- 4) On the fourth service, the value read by channel 4 in service 2 is now written to its destination address and the channel becomes the lowest priority.

Figure 11–12. Service Sequence for Split Mode Priority Example

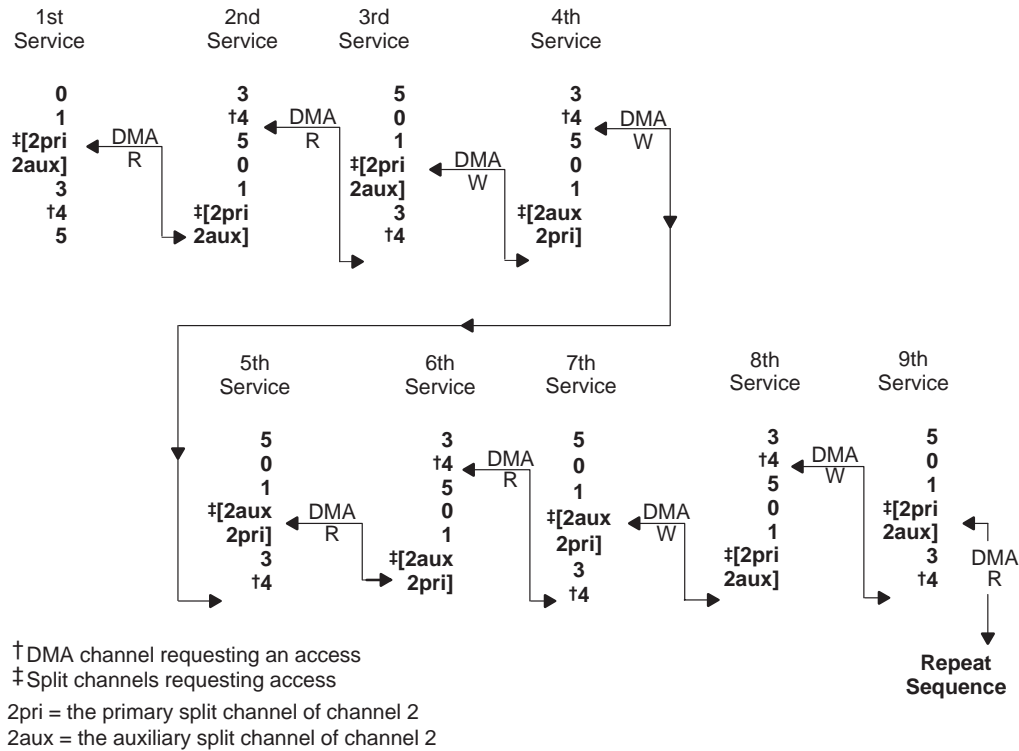

- 5) In the fifth service, 2aux is read and channel 2 becomes the lowest priority.
- 6) On the sixth service, channel 4 is read again, and it becomes the lowest priority.
- 7) On the seventh and eighth services, the 2aux and channel 4 values that were read in services 5 and 6 are now written to their destination addresses. After the channel is written, it assumes the lowest priority.
- 8) In the ninth service, 2pri is read again as in the first service, and the read/write cycle continues as begun in the first service.

11.7 CPU and DMA Coprocessor Arbitration

The DMA coprocessor transfers data on its own internal buses. Arbitration is necessary only when a resource conflict exists between the DMA coprocessor and the CPU. The arbitration causes no delay. When there is no conflict, the CPU and DMA coprocessor accesses proceed in parallel.

All arbitration between the CPU and the DMA coprocessor is on an access basis; that is, the DMA coprocessor must contend for read and write accesses in both unified and split modes. *DMA coprocessor internal memory access starts during H3* (See Section 8.4, *Clocking of Memory Accesses*, on page 8-19, for more information).

When the CPU and DMA coprocessor request the same resource, the DMA channel's DMA PRI bits (bits 0 and 1 of the channel control register) define the arbitration rules (as shown in Table 11–7). The CPU has higher priority than the DMA when DMA PRI = 00₂; it has lower priority than the DMA when DMA PRI = 11₂. They rotate priority when DMA PRI = 01₂.

Table 11–7. DMA PRI Bits and CPU/DMA Arbitration Rules

DMA PRI (Bits 1–0)	Description
0 0	DMA access is lower priority than the CPU access. If the DMA channel and the CPU are requesting the same resource, then the CPU will proceed. (DMA PRI bits are set to 00 ₂ at reset.)
0 1	This setting selects <i>rotating</i> arbitration, which sets priorities between the CPU and DMA channel by alternating their accesses, but not exactly equally. Priority rotates between CPU and DMA accesses when they conflict during <i>consecutive instruction cycles</i> . The first time the DMA channel and the CPU request the same resource, the CPU has priority. If, in the following instruction cycle, the DMA coprocessor and the CPU again request the same resource, the DMA has priority. Alternate access continues as long as the CPU and DMA requests conflict in consecutive instruction cycles. When there is no conflict in a previous instruction cycle, the CPU has priority.
1 0	Reserved
1 1	DMA access is higher priority than the CPU access. If the DMA channel and the CPU are requesting the same resource, <i>the DMA will proceed</i> .

11.8 Data Transfer Modes

Each DMA channel can operate in four types of data transfer modes. These modes differ in:

- Whether or not they use autoinitialization
- How they operate if autoinitialization is in effect or not

Table 11–8 and the following paragraphs describe these data transfers.

Table 11–8. TRANSFER MODE (AUX TRANSFER MODE) Field Descriptions

TRANSFER MODE (AUX TRANSFER MODE) Bits 3–2 (5–4)	Description
0 0 ₂	Transfers are not terminated by the transfer counter. No autoinitialization is performed. The TCINT (transfer count interrupt) bits can still be used to cause an interrupt when the transfer counter makes a transition to zero. The DMA channel continues to run.
0 1 ₂	Transfers are terminated by the transfer counter. No autoinitialization is performed. A halt code of 10 ₂ is placed in the START or AUX START field (bits 22–23 or bits 24–25 of the DMA channel control register) when transfers are complete.
1 0 ₂	Autoinitialization 1. Autoinitialization is performed when the transfer counter goes to zero without waiting for CPU intervention.
1 1 ₂	Autoinitialization 2. The DMA channel is autoinitialized when the CPU restarts the DMA coprocessor by using the DMA channel control register in the CPU. When the transfer counter goes to zero, operation is halted until the CPU starts the DMA coprocessor by using the START (or AUX START) field in the DMA channel control register. A halt code of 10 ₂ is placed in the START (or AUX START) field by the DMA.

11.8.1 Running in TRANSFER MODE = 00₂

When TRANSFER MODE = 00₂, transfers are not terminated when the transfer counter goes to zero, and no autoinitialization is performed. Even though the transfer counter does not halt transfers, an interrupt can be generated on the transfer counter transition to zero, setting the TCINT FLAG bit to 1. If the DMA coprocessor channel is not halted after the transfer reaches zero, the counter will continue decrementing below zero.

11.8.2 Running in TRANSFER MODE = 01₂

When TRANSFER MODE = 01₂, transfers are terminated when the transfer counter goes to zero, and no autoinitialization is performed. When the transfer counter goes to zero, the DMA channel is halted by forcing 10₂ into the START or AUX START field.

11.8.3 Running in TRANSFER MODE = 10₂ (Autoinitialization 1)

This transfer mode allows the DMA channel to run continuously, change pointers and synchronization by the autoinitialization procedure, and turn itself off. Two different autoinitialization methods are supported:

Autoinitialization method 1a always starts after a system reset, after a DMA channel is reset (00₂ written to the START or AUX START bits), or after a DMA channel halts (01₂ or 10₂ written to START or AUX START bits). To select transfer mode 10₂ (autoinitialization method 1a), follow the steps listed here and shown in Figure 11–13.

- 1) Initialize the DMA control register to transfer mode 10₂, and reset or halt the DMA channel to be autoinitialized.
- 2) Initialize the transfer counter to 0 (resetting the DMA channel does this).
- 3) Initialize the DMA channel link pointer with the address where the autoinitialization values reside. No initialization of the other DMA channel registers is required, because they are automatically set up during the autoinitialization process.
- 4) Start the DMA channel by writing 11₂ to the START (or AUX START) bits.
- 5) The DMA channel performs the sequence, *autoinitialize and block transfer*.

Figure 11–13. DMA Channel Running in Transfer Mode 10₂ (Autoinitialization Method 1a)

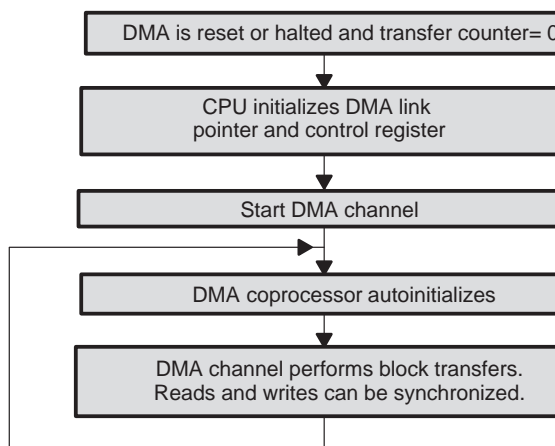

Autoinitialization method 1b starts when the transfer counter is not zero. The DMA starts a regular DMA transfer and autoinitializes after this transfer completes (when the transfer counter becomes zero). To select transfer mode 10_2 (autoinitialization method 1b), follow the steps listed here and shown in Figure 11–14.

- 1) Initialize the DMA control register to transfer mode 10_2 , and reset or halt the DMA channel for the first transfer operation.
- 2) Initialize all the other DMA channel registers (source address, destination address, transfer counter, etc.) according to the transfer operation desired. Note that the transfer counter now reflects the number of words to be transferred (normally a nonzero value) before the autoinitialization process.
- 3) Initialize the DMA channel link pointer with the address where the autoinitialization values for subsequent transfer operations reside.
- 4) Start the DMA channel by writing 11_2 to the START (or AUX START) bits.
- 5) The DMA channel performs this sequence: *block transfer and autoinitialize* (reverse order of method 1a).

Note that if a DMA channel is programmed to perform n block transfers, autoinitialization method 1a requires n DMA autoinitialization values. Autoinitialization method 1b requires only $n-1$ autoinitialization values because the first transfer can be accomplished during the initial DMA transfer. This represents some memory saving, but successive identical DMA operations require extra CPU cycles to set the initial DMA registers values again.

Figure 11–14. DMA Channel Running in Transfer Mode 10_2 (Autoinitialization Method 1b)

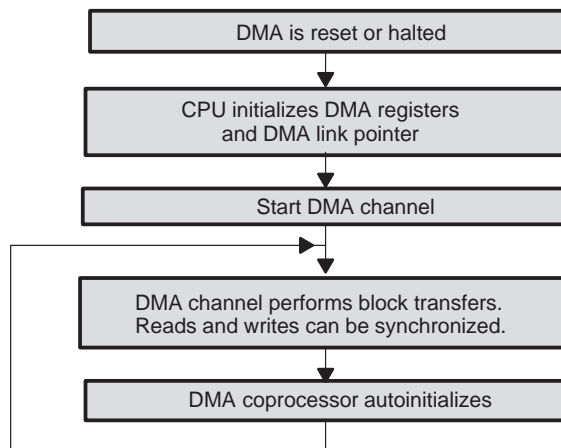

11.8.4 Running in TRANSFER MODE = 11₂ (Autoinitialization 2)

This transfer mode, besides having all of the advantages of autoinitialization, allows the CPU to coordinate its operation very easily with the operation of the DMA channels. Two different autoinitialization methods are supported:

Autoinitialization method 2a always starts after a system reset, after a DMA channel reset (00₂ written to the START or AUX START bits), or after a channel halts (01₂ or 10₂ written to the START or AUX START bits). To select transfer mode 11₂ and use autoinitialization method 2a, follow the steps listed here and shown in Figure 11–15.

- 1) Initialize the DMA control register to transfer mode 11₂ and reset or halt the DMA channel to be autoinitialized.
- 2) Initialize the transfer counter to 0 (resetting the DMA channel does this).
- 3) Initialize the DMA channel link pointer with the address where the autoinitialization values reside. No initialization of the other DMA channel registers is required, because they are automatically set up during the autoinitialization process.
- 4) Start the DMA channel by writing 11₂ to the START or AUX START bits.
- 5) The DMA channel autoinitializes itself and performs a block transfer.
- 6) When the transfer counter goes to zero, the DMA waits for the CPU to write a 11₂ to the START(or AUX START) field of the DMA channel control register and autoinitialize.
- 7) Repeat the sequence *autoinitialize, transfer, and wait*.
- 8) When the transfer counter goes to zero, you can halt the DMA channel by forcing 10₂ into the START (or AUX START) field.

Figure 11–15. DMA Channel Running in Transfer Mode 11₂ (Autoinitialization Method 2a)

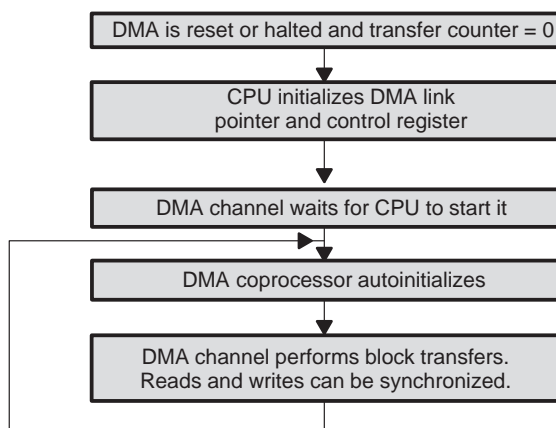

Autoinitialization method 2b starts when the transfer counter is not zero. The DMA starts with a regular DMA transfer and autoinitializes after this transfer completes (when the transfer counter becomes zero). To select transfer mode 11_2 and use autoinitialization mode 2b, follow the steps listed here and shown in Figure 11–16.

- 1) Initialize the DMA control register to transfer mode 11_2 and reset or halt the DMA channel for the first transfer operation.
- 2) Initialize the other DMA channel registers (source address, destination address, transfer counter, etc.) accordingly. Note that the transfer counter now reflects the number of words to be transferred (normally a nonzero value) before the autoinitialization process.
- 3) Initialize the DMA channel link pointer with the address where the autoinitialization values for subsequent transfer operations reside.
- 4) Start the DMA channel by writing 11_2 to the START(or AUX START) bits.
- 5) The DMA channel performs the initial block transfer. When the transfer counter goes to zero, the DMA waits for the CPU to write a 11_2 to the START or AUX START field of the DMA channel control register and auto-initialize.
- 6) Repeat the sequence *transfer, wait, and autoinitialize*.

Note that if a DMA channel is programmed to perform n block transfers, using autoinitialization method 2a requires n DMA autoinitialization values. Autoinitialization method 2b requires only $n-1$ autoinitialization values because the first transfer can be accomplished during the initial DMA transfer. This represents some memory saving, but successive identical DMA operations require extra CPU cycles to set the initial DMA register values again.

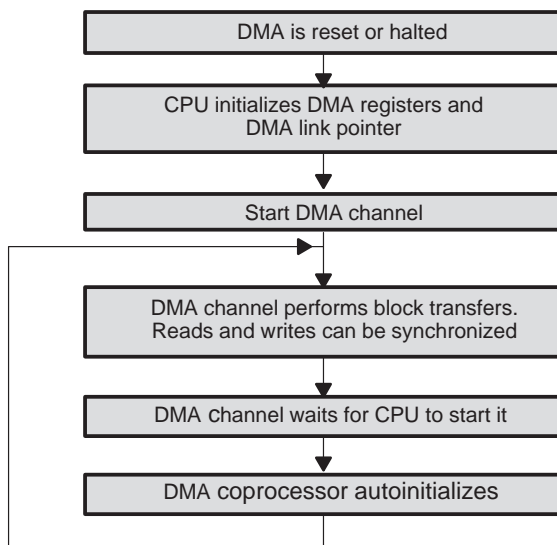
Figure 11–16. DMA Channel Running in Transfer Mode 11₂ (Autoinitialization Method 2b)

11.9 Autoinitialization

Autoinitialization is a method for reloading a DMA channel register file when the transfer counter goes to zero. When the DMA channel is operating in autoinitialization mode, the link pointer register and auxiliary link pointer register are used to initialize the registers that control the operation of the DMA channel. These pointers are memory address locations for blocks of data that are to be loaded into the DMA register file, shown in Figure 11–1. Link pointers are covered in subsection 11.3.4, *Link Pointer and Auxiliary Link–Pointer Registers*.

Autoinitialization is a regular DMA block transfer operation in which the destination is the DMA coprocessor's register file. The DMA reads the value pointed to by the link pointer and writes it to the DMA register over the peripheral bus on the next available cycle. Consequently, autoinitialization read/write accesses are also subject to any normal CPU/DMA access conflict.

Autoinitialization can happen:

- Without CPU intervention when the TRANSFER MODE bits = 10_2 (autoinitialization 1). Refer to subsection 11.8.3, *Running in TRANSFER MODE = 10_2 (Autoinitialization 1)*.
- With CPU intervention when the TRANSFER MODE bits = 11_2 (autoinitialization 2). In this case, the CPU should restart the DMA channel before the autoinitialization proceeds. Refer to subsection 11.8.4, *Running in TRANSFER MODE = 11_2 (Autoinitialization 2)*.
- Before any block transfer (autoinitialization method a). The DMA starts with the transfer counter at zero, then autoinitializes and performs a block transfer.
- After a block transfer (autoinitialization method b). The DMA starts with a regular block transfer, and, when the transfer counter register goes to zero, it autoinitializes.

Autoinitialization 1 or 2 can use methods a or b.

Autoinitialization depends on the DMA channel's current mode: split or unified mode. The mode of operation is controlled by the SPLIT MODE bit (bit 14 in Figure 11–2). When autoinitializing the DMA coprocessor, *do not change* the SPLIT MODE bit. This bit should be changed *only when the DMA coprocessor has been reset and halted* (see DMA START bit description in Table 11–5 for more information).

11.9.1 Unified Mode

If the DMA channel is running in unified mode ($SPLIT\ MODE = 0$), the link pointer is used and the DMA-channel registers are loaded in the following order:

- 1) DMA-channel control register
- 2) Source-address register
- 3) Source-address index register
- 4) Transfer-counter register
- 5) Destination-address register
- 6) Destination-address index register
- 7) Link-pointer register

The storage of new values for these registers in memory is illustrated in Figure 11–17.

Figure 11–17. Store New Values of DMA Channel Registers in Memory ($SPLIT\ MODE = 0$)

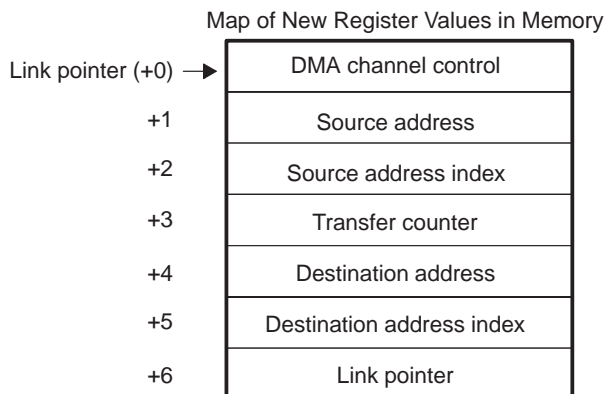

11.9.2 Split Mode

If the DMA channel is running in split mode ($SPLIT\ MODE = 1$), then the autoinitialize sequence depends upon which counter has terminated.

If the transfer counter register has gone to zero with $SPLIT\ MODE = 1$, then the link-pointer register is used for autoinitialization. In this case, the DMA channel registers are loaded in the following order:

- 1) DMA-channel control register
- 2) Source-address register
- 3) Source-address index register
- 4) Transfer-counter register
- 5) Link-pointer register

The storage of the new values for these registers in memory is illustrated in Figure 11–18.

Figure 11–18. Store New Values of DMA Channel Registers in Memory (*SPLIT MODE = 1* and *Transfer Counter = 0*)

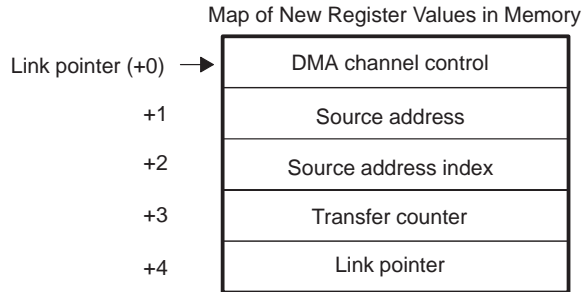

If the auxiliary transfer counter register has gone to zero with *SPLIT MODE=1*, then the auxiliary link pointer register is used for autoinitialization. In this case, the DMA channel registers are loaded in the following order:

- 1) DMA channel control register
- 2) Destination address register
- 3) Destination address index register
- 4) Auxiliary transfer count register
- 5) Auxiliary link pointer register

The storage of the new values of these registers in memory is illustrated in Figure 11–19.

Figure 11–19. Store New Values of DMA Channel Registers in Memory (*SPLIT MODE = 1* and *Auxiliary Transfer Counter = 0*)

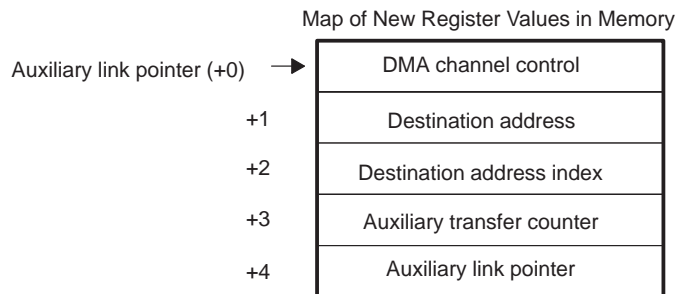

11.9.3 Incrementing the Link Pointer

During autoinitialization, the link pointer can be incremented or held constant:

- When the link pointer is incremented, the autoinitialization values are stored in sequential memory locations, and the link pointer or auxiliary link pointer is incremented in order to access each of these locations.

- ❑ When you autoinitialize the DMA channel from a stream-oriented device, such as the on-chip communication ports or external FIFOs, you should hold the link pointer **constant**.

This can be controlled by the AUTOINIT STATIC and the AUX AUTOINIT STATIC bits of the DMA control register as follows:

- ❑ In unified mode, the AUTOINIT STATIC bit controls the link pointer.
- ❑ In split mode, the AUTOINIT STATIC bit controls the link pointer (primary channel), and the AUX AUTOINIT STATIC controls the auxiliary linker pointer.

When the AUTOINIT STATIC (AUX AUTOINIT STATIC) bit is zero, the link pointer is incremented. When it is one, the link pointer is held constant.

11.9.4 Synchronization

Usually, autoinitialization data is stored in memory, and synchronization is not necessary. In some cases, you may wish to transfer autoinitialization data in the same way as in the synchronized data reads and writes.

Autoinitialization synchronization is a function of the:

- ❑ SYNC MODE bits (DMA channel control register bits 6 and 7) that control synchronization of data transfers, and
- ❑ AUTOINIT SYNC bits (DMA channel control register bits 10 and 11) that affect only autoinitialization synchronization.

If the SYNC MODE bits are not set to synchronize data transfers (i.e., if the preceding data transfer is not synchronized on interrupts), then the DMA channel autoinitialization sequence is not synchronized either. If the SYNC MODE bits are set to transfer data synchronously (if the preceding data transfer is synchronized), then the upcoming data channel autoinitialization sequence can be synchronized on reads or writes or both (depending on whether the DMA coprocessor is in unified or split mode) as shown in Table 11–9. Note that when both modes show "no sync" for a bit setting in the table, the DMA channel autoinitialization sequence is not synchronized on interrupts.

In unified mode, there is no write synchronization for autoinitialization operation, because the destination is the DMA register, which is always ready.

In split mode, bit 6 of the DMA control register controls the autoinitialization synchronization of the DMA primary channel, and bit 7 controls the autoinitialization synchronization of the DMA auxiliary channel.

If primary channel autoinitialization synchronization is used, the DMA read of autoinitialization values from memory does not proceed until the interrupt specified in the DMAx primary write field in the DIE register is received.

If auxiliary channel autoinitialization synchronization is used, the DMA read of autoinitialization values from memory does not proceed until the interrupt specified in the DMAx auxiliary read field in the DIE register is received.

Table 11–9. Effect of SYNC MODE and AUTOINIT MODE Bits in Autoinitialization

SYNC MODE		AUTOINIT SYNC	
Bit Numbers 7 – 6	Bit Numbers 11 – 10	Unified Mode	Split Mode
0 0	0 0	No synchronization	No synchronization
0 0	0 1	No synchronization	No synchronization
0 0	1 0	No synchronization	No synchronization
0 0	1 1	No synchronization	No synchronization
0 1	0 0	No synchronization	No synchronization
0 1	0 1	Read	Primary channel
0 1	1 0	No synchronization	No synchronization
0 1	1 1	Read	Primary channel
1 0	0 0	No synchronization	No synchronization
1 0	0 1	No synchronization	No synchronization
1 0	1 0	No synchronization	Auxiliary channel
1 0	1 1	No synchronization	Auxiliary channel
1 1	0 0	No synchronization	No synchronization
1 1	0 1	Read	Primary channel
1 1	1 0	No synchronization	Auxiliary channel
1 1	1 1	Read	Auxiliary and primary channels

11.9.5 Effect on DMA Control Register Bits

In unified mode, all of the writable control register bits are affected by autoinitialization. These bits are labeled in Figure 11–20.

Figure 11–21. DMA Channel Control Register Bit Modifiable by Autoinitialization of the Primary Channel in Split Mode

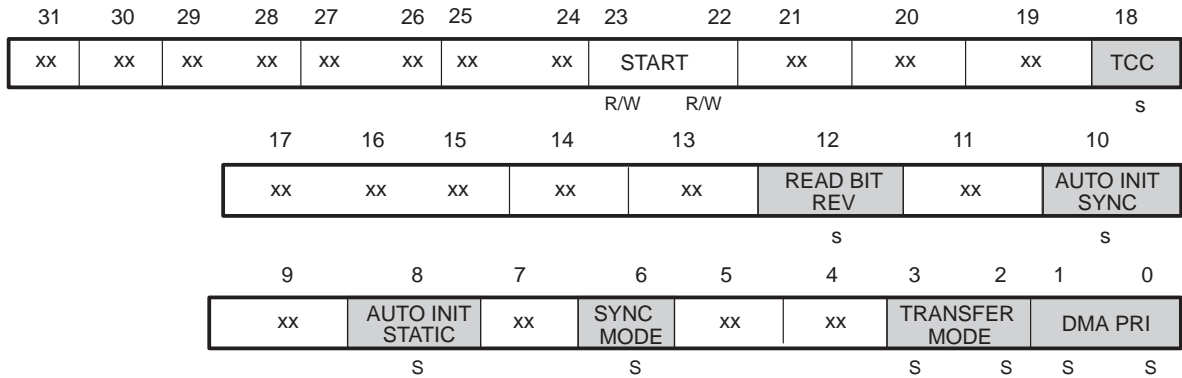

s — These shadowed bits do not take effect until autoinitialization is complete.
 xx — Write protected during primary channel autoinitialization.

Figure 11–22. DMA Channel Control Register Bits That Can Be Modified by Autoinitialization of the Auxiliary Channel in Split Mode

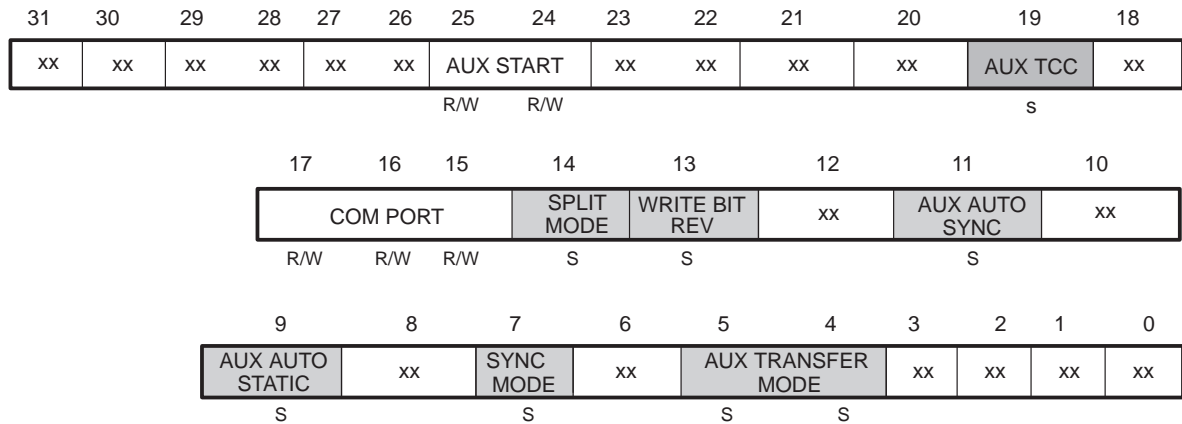

s — These shadowed bits do not take effect until autoinitialization is complete.
 xx — Write protected during auxiliary channel autoinitialization.

11.9.6 Consecutive Autoinitializations

For many applications, it is sufficient to autoinitialize the DMA channel with the same data each time. In this case, the new link-pointer value points to the start of the same block of data containing the new link pointer, as illustrated in Figure 11–23. This particular example assumes that the DMA channel is not running in split mode.

If you want, you can make the new link pointer point to a new set of register values, as illustrated in Figure 11–24. This can be continued to any level.

Figure 11–23. Self-Referential Link Pointer

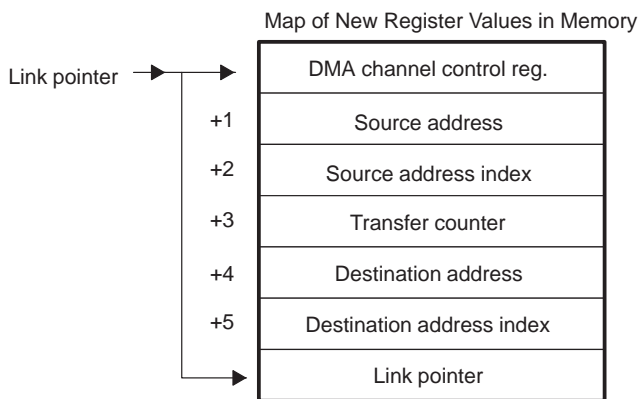
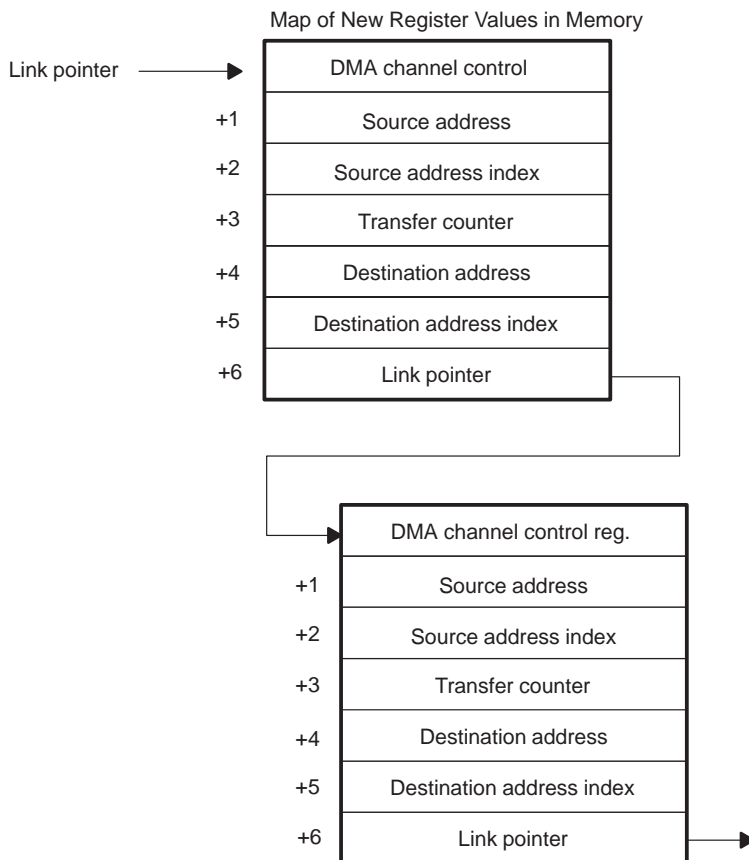

Figure 11–24. Referring to a New Link Pointer



11.10 DMA and Interrupts

The DMA coprocessor uses interrupts in the following way:

- ❑ It can send interrupts to the CPU when a block transfer finishes. See the TCC and AUX TCC bits in Figure 11–2.
- ❑ It can receive interrupts from the external interrupt pins ($\overline{\text{IIOF3}}\text{--}0$), the timers, or the communication port (ICRDY, OCRDY).

This section explains how the DMA receives interrupts. This process is called synchronization.

All of the interrupts that the DMA coprocessor can see are first received by the CPU interrupt controller. Edge-triggered interrupts are latched by the CPU in the appropriate interrupt flag register; level-triggered interrupts are not.

When an external interrupt ($\overline{\text{IIOF3}}\text{--}0$) is used for DMA coprocessor transfer synchronization, the CPU is responsible for configuring external interrupts as edge- or level-triggered interrupts (as set in the FUNCx and TYPEx bits of the interrupt flag register (discussed in subsection 3.1.10, *IIOF Flag Register (IIF)*), on page 3-13).

Edge-triggered interrupts are timer interrupts, DMA interrupts, and external interrupts that are configured as edge-triggered interrupts. Detailed information on interrupts is provided in Section 7.4, *Interrupts*, on page 7-15, and Section 7.6, *DMA Interrupts*, on page 7-26. When the interrupt controller determines that an edge-triggered interrupt that a DMA channel is waiting on (DIE registers bits set) has been latched into the interrupt flag, the CPU clears the interrupt flag and sends an interrupt pulse to the DMA channel. The DMA channel latches the interrupt locally until it can service the interrupt. At that time, the latched interrupt is cleared by the DMA coprocessor for two cycles.

Level-triggered interrupts generated by communication ports and external interrupts that are configured as level-triggered interrupts are handled differently by the CPU interrupt controller. When the interrupt controller determines that a level-triggered interrupt that a DMA channel is waiting for (DIE register bits set) has been received, the CPU sends an interrupt pulse to the DMA channel. The DMA channel latches the interrupt locally until it can service the interrupt. At that time, the locally latched interrupt is cleared by the DMA coprocessor for two cycles.

The interrupt reset signal generated by the DMA coprocessor after a DMA interrupt is serviced has priority over the interrupt set signal. Thus, the interrupt signal will not be continuously set, even if the CPU is continuously sending the interrupt set signal. Therefore, when the DMA-set priority scheme is used and

a higher priority DMA channel is driven by continuous interrupt signals, the lower priority DMA channel can be serviced in between the higher priority DMA services.

Unlike the 'C3x, the 'C4x DMA processor is not affected by processing the CPU interrupts, even when pipeline fetches are being halted. When interrupts are enabled in the DIE register, the interrupt is latched automatically by the CPU interrupt controller and saved for future DMA use. When a flag interrupt (timer, external interrupt) is latched, the IIF flag is cleared. Note that IIF flags are cleared when the CPU interrupt controller latches the interrupt, not when the DMA responds to it. Even if the DMA has not been started, the interrupt latch occurs, except when the start bits in the DMA control register have the reset value (00₂ in the START or AUX START bits). DMA reset clears the interrupt internal latch. To avoid losing previously received interrupts, it is recommended that you initialize DIE register after starting the DMA, when the DMA start bits have the value 11₂. Note that when the DMA completes a transfer, the start (AUXSTART) bits are set to 10₂. For this reason, the DMA will not miss any interrupt between transfers.

The DMA and the CPU can respond to the same interrupt if the CPU is not involved in any pipeline conflict or in any instruction that halts instruction fetching. Refer to subsection 7.4.1, *Interrupt Vector Table and Prioritization*, on page 7-15 for more details. It is also possible for different DMA channels (including auxiliary and primary channels) to respond to the same interrupt. If the same interrupt is selected for source and destination synchronization, both read and write cycles are enabled with a single incoming interrupt.

The internal circuitry of the 'C4x guarantees proper operation between a communication port that generates level-triggered interrupts and the DMA channel that is synchronizing with those level-triggered interrupts.

Note:

When you synchronize the DMA channels with external interrupts, it is better to configure the interrupt lines as edge-triggered interrupts to ensure that only one interrupt is recognized.

11.10.1 Interrupts and Synchronization of DMA Channels

You can use interrupts to synchronize DMA channel transfers. To set up the DMA for a synchronous data transfer mode requires two steps:

- 1) Set the DMA SYNC MODE bits (bits 6,7) in the DMA channel control register to the value for the source, destination, or source and destination synchronization desired. See subsection 11.10.2, *Synchronization Mode Bits*, for more information.

- 2) Set the DIE register to enable the corresponding interrupt for the DMA transfer synchronization desired. Figure 11–25 and Figure 11–26 show the DIE register for the split and unified modes, respectively. Table 11–10 and Table 11–11 lists the different synchronization interrupts for unified mode, and Table 11–12 and Table 11–13 list them for split mode.

It is recommended that you initialize the DIE register after starting the DMA, when the start bits have the value 11₂. This prevents losing previously received interrupts, which may occur if you enable the DIE register when the start bits are 00₂ (reset value).

Figure 11–25. DIE Register Bit Functions for DMA Unified Mode

31	30	29	28	27	26	25	24	23	22	21	20
DMA5 Write			DMA5 Read			DMA4 Write			DMA4 Read		
R/W	R/W	R/W	R/W	R/W	R/W	R/W	R/W	R/W	R/W	R/W	R/W
19	18	17	16	15	14	13	12	11	10	9	8
DMA3 Write			DMA3 Read			DMA2 Write			DMA2 Read		
R/W	R/W	R/W	R/W	R/W	R/W	R/W	R/W	R/W	R/W	R/W	R/W
7	6	5	4	3	2	1	0				
DMA1 Write		DMA1 Read		DMA0 Write		DMA0 Read					
R/W	R/W	R/W	R/W	R/W	R/W	R/W	R/W				

R = Read W = Write

Table 11–10. DMA Channels 0 and 1 (DMA0 and DMA1) Unified-Mode Synchronization Interrupts

Bit Value (in DMA0 or DMA1)	Interrupt Enabled at DMA0 or DMA1				Interrupt Source for DMA Synchronization
	DMA0 Read	DMA0 Write	DMA1 Read	DMA1 Write	
0 0†	None	None	None	None	--
0 1	ICRDY0	OCRDY0	ICRDY1	OCRDY1	From communication port
1 0	$\overline{\text{IIOF0}}$	$\overline{\text{IIOF1}}$	$\overline{\text{IIOF2}}$	$\overline{\text{IIOF3}}$	From external pins $\overline{\text{IIOF0}}$ – $\overline{\text{IIOF3}}$
1 1	TIM0	TIM0	TIM0	TIM0	From timer TIM0

† DMA channel halts (no read or write operation proceeds) if DMA synchronous transfer is used.

Table 11–11. DMA Channels 2 to 5 (DMA2 to DMA5) Unified-Mode Synchronization Interrupts

Bit Value (in DMA2 to DMA5)	Interrupt Enabled at DMA2–DMA5†		Interrupt Source for DMA Synchronization
	DMA x Read†	DMA x Write†	
0 0 0‡	None	None	--
0 0 1	ICRDY x †	OCRDY x †	From communication port
0 1 0	$\overline{\text{IIOF0}}$	$\overline{\text{IIOF0}}$	From external pins $\overline{\text{IIOF0}}$ – $\overline{\text{IIOF3}}$
0 1 1	$\overline{\text{IIOF1}}$	$\overline{\text{IIOF1}}$	
1 0 0	$\overline{\text{IIOF2}}$	$\overline{\text{IIOF2}}$	
1 0 1	$\overline{\text{IIOF3}}$	$\overline{\text{IIOF3}}$	
1 1 0	TIM0	TIM0	From timers TIM0 and TIM1
1 1 1	TIM1	TIM1	

† The x in DMA x represents the DMA channel number and also the number for the corresponding ICRDY x and OCRDY x interrupts. For example, an 001₂ in both DMA2 READ and DMA5 WRITE would enable interrupts ICRDY2 and OCRDY5, respectively. All other viable bit values (010₂ to 111₂) are the same (as shown in the table) for DMA2 through DMA5.

‡ DMA channel halts (no read or write operation proceeds) if DMA synchronous transfer is used.

Figure 11–26. DIE Register Bit Functions for DMA Split Mode

31	30	29	28	27	26	25	24	23	22	21	20
DMA5 Primary Write			DMA5 Auxiliary Read			DMA4 Primary Write			DMA4 Auxiliary Read		
R/W	R/W	R/W	R/W	R/W	R/W	R/W	R/W	R/W	R/W	R/W	R/W
19	18	17	16	15	14	13	12	11	10	9	8
DMA3 Primary Write			DMA3 Auxiliary Read			DMA2 Primary Write			DMA2 Auxiliary Read		
R/W	R/W	R/W	R/W	R/W	R/W	R/W	R/W	R/W	R/W	R/W	R/W
7	6	5	4	3	2	1	0				
DMA1 Primary Write		DMA1 Auxiliary Read		DMA0 Primary Write		DMA0 Auxiliary Read					
R/W	R/W	R/W	R/W	R/W	R/W	R/W	R/W				

R = Read W = Write

Table 11–12. DMA Channels 0 and 1 (DMA0 and DMA1) Split-Mode Synchronization Interrupts

Bit Value (in DMA0 or DMA1)	Interrupt Enabled at DMA0 or DMA1				Interrupt Source for DMA Synchronization
	DMA0 Auxiliary Read	DMA0 Primary Write	DMA1 Auxiliary Read	DMA1 Primary Write	
0 0†	None	None	None	None	--
0 1	ICRDY0	OCRDY0	ICRDY1	OCRDY1	From communication port
1 0	$\overline{\text{IIOF0}}$	$\overline{\text{IIOF1}}$	$\overline{\text{IIOF2}}$	$\overline{\text{IIOF3}}$	From external pins $\overline{\text{IIOF0}}$ – $\overline{\text{IIOF3}}$
1 1	TIM0	TIM0	TIM0	TIM0	From timer TIM0

† DMA channel halts (no read or write operation proceeds) if DMA synchronous transfer is used.

Table 11–13. DMA Channels 2 to 5 (DMA2 to DMA5) Split-Mode Synchronization Interrupts

Bit Value (in DMA2 to DMA5)	Interrupt Enabled at DMA2–DMA5†		Interrupt Source for DMA Synchronization
	DMAx Auxiliary Read†	‡DMAx Primary Write†	
0 0 0‡	None	None	--
0 0 1	ICRDYx†	OCRDYx†	From communication port
0 1 0	$\overline{\text{IIOF0}}$	$\overline{\text{IIOF0}}$	From external pins $\overline{\text{IIOF0}}$ – $\overline{\text{IIOF3}}$
0 1 1	$\overline{\text{IIOF1}}$	$\overline{\text{IIOF1}}$	
1 0 0	$\overline{\text{IIOF2}}$	$\overline{\text{IIOF2}}$	
1 0 1	$\overline{\text{IIOF3}}$	$\overline{\text{IIOF3}}$	
1 1 0	TIM0	TIM0	From timers TIM0 and TIM1
1 1 1	TIM1	TIM1	

† The x in DMAx represents the DMA channel number and also the number for the corresponding ICRDYx and OCRDYx interrupts. For example, an 001₂ in both DMA2 READ and DMA5 WRITE would enable interrupts ICRDY2 and OCRDY5, respectively. All other viable bit values (010₂ to 111₂) are the same (as shown in the table) for DMA2 through DMA5.

‡ DMA channel halts (no read or write operation proceeds) if DMA synchronous transfer is used.

11.10.2 Synchronization Mode Bits

Table 11–3 and Table 11–4 describe how the bit values of the SYNC MODE field of the DMA channel control register determine synchronization in unified and split mode, respectively:

- No synchronization (SYNC MODE = 00₂)
- Source synchronization
 - for unified mode (SYNC MODE = 01₂)
 - for split mode (SYNC MODE = 10₂)
- Destination synchronization
 - for unified mode (SYNC MODE = 10₂)
 - for split mode (SYNC MODE = 01₂)
- Source and destination synchronization (SYNC MODE = 11₂)

When the 'C4x DMA is in split mode, the primary channel supports write (or destination) synchronization transfers only, and the auxiliary channel supports read (or source) synchronization transfers only. In split mode, bits 6 and 7 of the DMA channel control register (as shown in Table 11–3) are used to control channel synchronization:

- Bit 6** controls primary write channel synchronization (destination synchronization).
- Bit 7** controls auxiliary read channel synchronization (source synchronization).

DMA transfer rate in synchronization mode is explained in subsection 11.11.2, *DMA Transfer Rate in Synchronization Mode*, on page 11-55.

No Synchronization

When SYNC MODE = 00₂, no synchronization is performed. The DMA performs reads and writes whenever it has the priority to use the DMA bus. All interrupts are ignored. Note the difference between this mode and having the zero value in the DIE read or write fields. Having zeros in the DIE register read/write fields results in a total DMA halt if synchronization is used, whereas SYNC MODE = 00₂ leaves the DMA channel running freely. Figure 11–27 shows the mechanism used when SYNC MODE = 00₂.

Figure 11–27. No DMA Synchronization

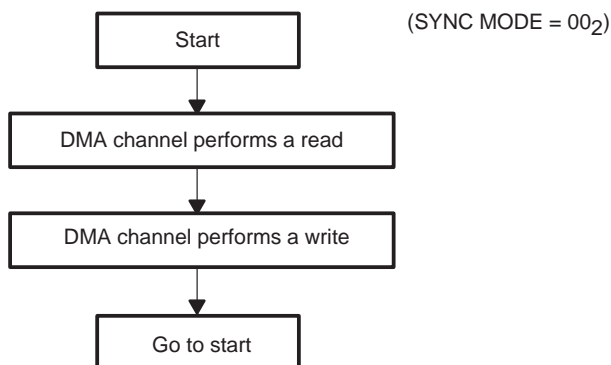

Source Synchronization

When SYNC MODE = 01₂ (for unified mode) or when SYNC MODE = 10₂ (for auxiliary channel in split mode), the DMA coprocessor is synchronized to the source (see Figure 11–28). A read will not be performed until an interrupt is received by the DMA channel. Then, all DMA interrupts are disabled globally. However, no bits in the DMA interrupt enable register are changed.

Figure 11–28. DMA Source Synchronization

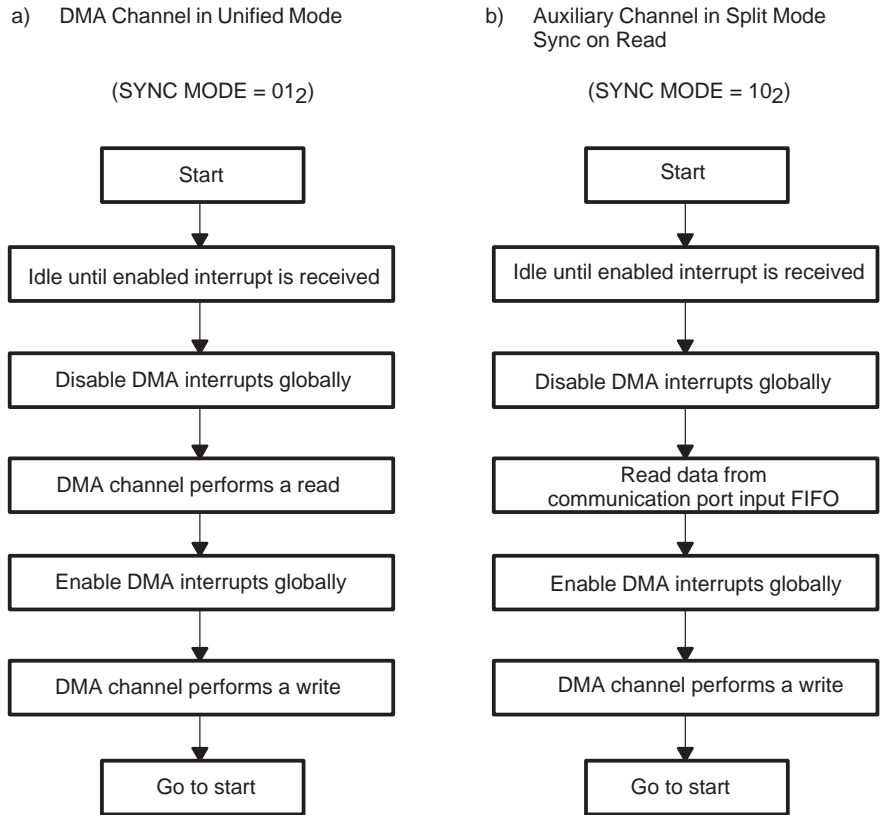

Destination Synchronization

When SYNC MODE = 10₂ (for unified mode) or when SYNC MODE = 01₂ (for primary channel in split mode), the DMA channel is synchronized to the destination. A write is not performed until an interrupt is received by the DMA channel. Figure 11–29 shows the synchronization mechanism.

In unified mode, the read is performed without waiting for the interrupt. However, in split mode, the read occurs only when the interrupt enabling the write is received. This avoids a lock situation that could happen if the primary channel

reads but never writes out of the temporary register, because it does not receive the write interrupt. In this case, the auxiliary channel could not proceed, because the DMA internal temporary register is busy.

Figure 11–29. DMA Destination Synchronization

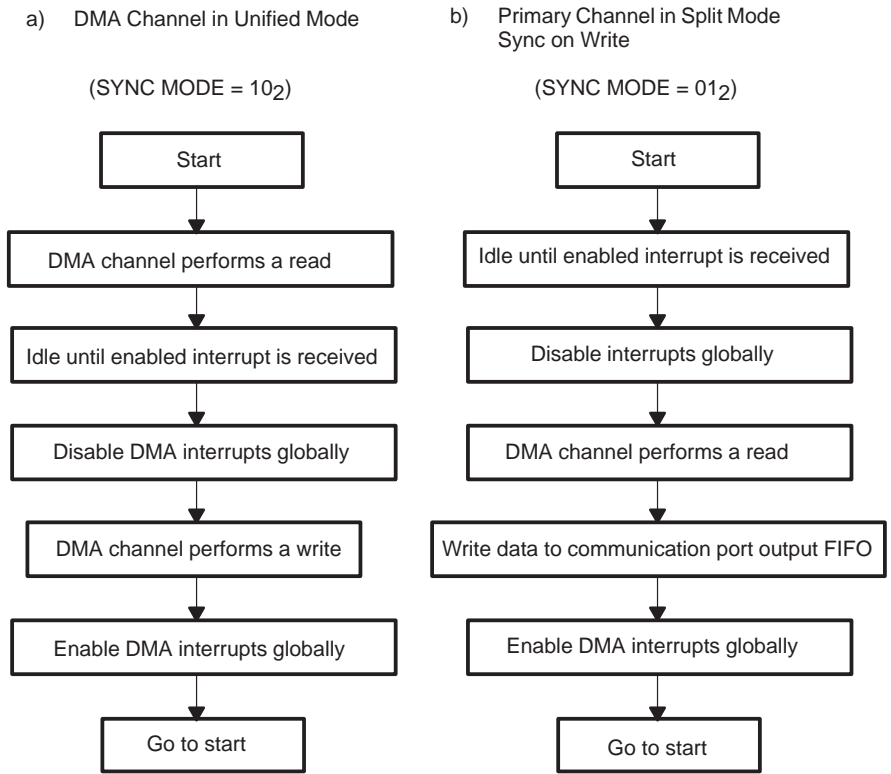

Source and Destination Synchronization

When SYNC MODE = 11₂, a read is performed when a read interrupt is received, and a write is performed on the write interrupt. If a write interrupt is received before a read interrupt, the write interrupt is latched, and the DMA data write is not executed until the read is completed. Unified mode source and destination synchronization (SYNC MODE = 11₂) is shown in Figure 11–30.

If DMA split mode is selected, it reacts as two independent synchronizations for the primary (write synchronization) and auxiliary (read synchronization) channels. Figure 11–28b and Figure 11–29b show this.

When the same interrupt is selected for read and write synchronization (in either split or unified mode), one single interrupt will enable both read and write operations.

Figure 11–30. Unified Mode DMA Source and Destination Synchronization

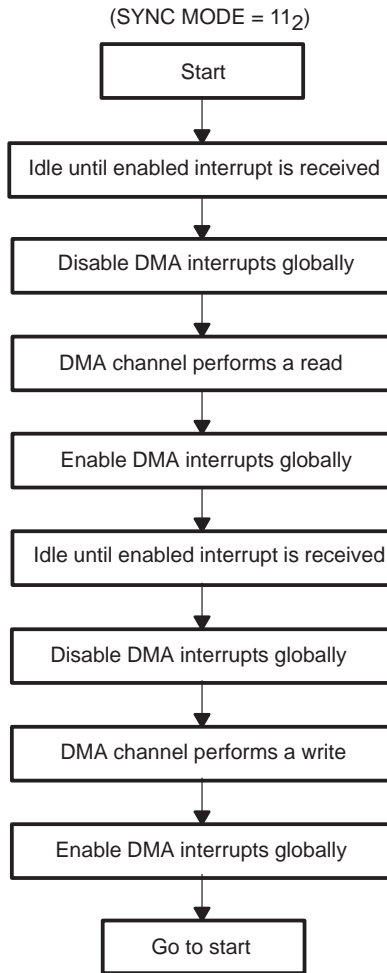

11.11 DMA Memory Transfer Timing

The 'C4x provides six DMA channels (twelve DMA channels if they are all in split mode) with a fixed/rotating priority arbitration scheme and configurable CPU/DMA priority scheme (for detailed information, see Section 11.6 for DMA internal priority schemes and Section 11.7, *CPU and DMA Coprocessor Arbitration*, for CPU and DMA priority arbitration).

The maximum data transfer rate that the 'C4x DMA sustains is one word every two cycles. The six DMA channels transfer data in a sequential time-slice fashion, rather than simultaneously, because they share common buses.

DMA memory transfer timing can be very complicated, especially if bus resource conflicts occur. However, some rules help you calculate the transfer timing for certain DMA setups. For simplification, the following subsection focuses on a single-channel DMA memory transfer timing with no conflict with the CPU or other DMA channels. You can obtain the actual DMA transfer timing by combining the calculations for single-channel DMA transfer timing with those for bus resource conflict situations.

11.11.1 Single DMA Memory Transfer Timing

When the DMA memory transfer has no conflict with the CPU or any other DMA channels, the number of cycles of a DMA transfer depends on whether the source and destination location are designated as on-chip memory, peripheral, or external ports. When the external port is used, the DMA transfer speed is affected by two factors: the external bus wait state and the read/write conflict (for example, if a write is followed by a read, the read takes two cycles). Figure 11–31 through Figure 11–33 show the number of cycles a DMA transfer requires from different sources to different destinations. Entries in the table represents the number of cycles required to do the T transfers, assuming that there are no pipeline conflicts. A timing diagram for the DMA transfers accompanies each figure.

Figure 11–31. Timing and Number of Cycles for DMA Transfers to On-Chip Destination

Cycles	T	1	2	3	4	5	6	7	8	9	10	11	12	13	14	15	16	17	18
Source on-chip	9	R		R		R		R		R		R		R		R		R	
Destination on-chip			W		W		W		W		W		W		W		W		W
Source local bus	4	R	R	R		R	R	R		R	R	R		R	R	R			
Destination on-chip			Cr			Cr			Cr			Cr			Cr				
Source global bus	4	R	R	R		R	R	R		R	R	R		R	R	R			
Destination on-chip			Cr			Cr			Cr			Cr			Cr				
Source global bus	4	R	R	R		R	R	R		R	R	R		R	R	R			
Destination on-chip			Cr			Cr			Cr			Cr			Cr				
Source global bus	4	R	R	R		R	R	R		R	R	R		R	R	R			
Destination on-chip			Cr			Cr			Cr			Cr			Cr				

Source	Destination: On-chip
On-chip	(1+1)T
Local bus	[(1+Cr)+1]T
Global bus	[(1+Cr)+1]T

Legend:

- T = Number of transfers
- Cr = Source-read wait states
- R = Single-cycle reads
- W = Single-cycle writes
- R R = Multicycle reads

Figure 11–32. Timing and Number of Cycles for DMA Transfers to a Local-Bus Destination

Cycles		T	1	2	3	4	5	6	7	8	9	10	11	12	13	14	15	16	17	18
Source on-chip	4	R		R				R				R								
Destination local bus			W	W	W	W	W	W	W	W	W	W	W	W	W	W	W	W	W	W
						Cw				Cw				Cw				Cw		
Source local bus	2	R	R	R				R	R	R	R									
Destination local bus				Cr						Cr										
						W	W	W	W				W	W	W	W				
Source global bus	3	R	R	R		R	R	R		R	R	R								
Destination local bus				Cr			Cr			Cr										
						W	W	W	W	W	W	W	W	W	W	W	W	W	W	W
								Cw				Cw					Cw			

Source	Destination: Local Bus
On-chip	$1+(2+Cw)T$
Local bus	$[(2+Cr)+(2+Cw)]T-1$
Global bus	$[(1+Cr)+(2+Cw)]+[2+\max(Cr,Cw)](T-1)$

Legend:

- T = Number of transfers
- Cr = Source-read wait states
- Cw = Destination-write wait states
- R = Single-cycle reads
- R R = Multicycle reads
- W W = Multicycle writes

Figure 11–33. Timing and Number of Cycles for DMA Transfers to a Global-Bus Destination

Cycles	T	1	2	3	4	5	6	7	8	9	10	11	12	13	14	15	16	17	18
Source on-chip	4	R		R				R				R							
Destination global bus			W	W	W	W	W	W	W	W	W	W	W	W	W	W	W	W	
						Cw				Cw				Cw				Cw	
Source local bus	3	R	R	R		R	R	R		R	R	R							
Destination global bus				Cr				Cr				Cr							
						W	W	W	W	W	W	W	W	W	W	W	W	W	
								Cw				Cw			Cw				
Source global bus	2	R	R	R					R	R	R	R							
Destination global bus				Cr								Cr							
						W	W	W	W					W	W	W	W		
								Cw							Cw				

Source	Destination: Global Bus
On-chip	$1+(2+Cw)T$
Local bus	$[(1+Cr)+(2+Cw)]+[2+\max(Cr,Cw)](T-1)$
Global bus	$[(2+Cr)+(2+Cw)]T-1$

Legend:
 T = Number of transfers
 Cr = Source-read wait states
 Cw = Destination-write wait states
 R = Single-cycle reads
 R R = Multicycle reads
 W W = Multicycle writes

Externally, on the global and local buses, writes take at least two cycles. However, internally, the CPU/DMA requires one cycle to perform the write to external memory. Therefore, the DMA/CPU can transfer data on the next cycle if it is not to the same external bus. For example, the DMA transfers 1024 words from internal memory RAM block 1 to a 1-wait-state memory on the global bus while the CPU runs from memory on the local bus and fetches operands from RAM block 0. The DMA transfer time is calculated from Figure 11–32 as $1 + (2+1)1024 = 1 + 3072 = 3073$ cycles.

11.11.2 DMA Transfer Rate in Synchronization Mode

The synchronization mode used for transfers also affects the DMA data transfer rate. The DMA data transfer rate is slower if synchronization is used because it takes two cycles to reset the request from the interrupt. However, these two extra cycles can be absorbed if multiple DMAs are running at the same time.

In unified mode, the maximum transfer rate is one word every three cycles, using synchronization. Figure 11–34 shows the number of cycles a DMA transfer requires under unified mode with different types of synchronization. For simplification, a single-channel DMA memory transfer timing with no conflict with CPU or other DMA channels, no memory wait states, and interrupts always active, is considered.

Figure 11–34. Unified-Mode DMA Timing for Different Synchronizations

Cycles	T	1	2	3	4	5	6	7	8	9	10	11	12	13	14	15	16	17	18	
No synchronization	9	R		R		R		R		R		R		R		R		R		
			W		W		W		W		W		W		W		W		W	
Read synchronization	6	R			R			R			R			R			R			
				Rr			Rr			Rr			Rr			Rr			Rr	
			W			W			W			W			W			W		
Write synchronization	5	R		R			R			R			R							
			W			W			W			W			W					
					Wr			Wr			Wr			Wr				Wr		
Read and write synchronization	5	R			R			R			R			R						
				Rr			Rr			Rr			Rr			Rr				
			W			W			W			W			W					
					Wr			Wr			Wr			Wr				Wr		

Synchronization	Timing
No synchronization	2T
Read synchronization	3T
Write synchronization	1 + 3T
Read and write synchronization	1 + 3T

Legend:

- T = Number of transfers
- R = Single-cycle reads
- W = Single-cycle writes
- Rr = Read flag-reset (2 cycles)
- Wr = Write-flag reset (2 cycles)

In split mode, the maximum transfer rate for either the primary or auxiliary channel is one word every four cycles, using synchronization. When auxiliary and primary channels are running at the same time, the two-cycle overhead for interrupt reset is absorbed, and the maximum transfer rate can be one word every two cycles. Figure 11–35 shows the number of cycles a DMA transfer requires in split mode with different types of synchronization. For simplification, a single-channel DMA memory transfer timing with no conflict with CPU or other DMA channels, no wait states, and interrupts always active, is considered.

Figure 11–35. Split-Mode DMA Timing for Different Synchronizations

Cycles	T	1	2	3	4	5	6	7	8	9	10	11	12	13	14	15	16	17	18	
No synchronization (both channels running)	8	R				R				R				R						
			W				W				W				W					
				R'					R'				R'				R'			
					W'					W'				W'				W'		
Primary channel synchronization (auxiliary channel not running)	4	R				R				R				R						
			W				W				W				W					
				Pr				Pr				Pr				Pr				
Auxiliary channel synchronization (primary channel not running)	4	R'				R'				R'				R'						
			W'				W'				W'				W'					
				Ar				Ar				Ar				Ar				
Primary and auxiliary channel synchronization (both channels running)	8	R				R				R				R						
			W				W				W				W					
				Pr				Pr				Pr				Pr				
				R'				R'				R'				R'				
					W'				W'				W'				W'			
						Ar				Ar					Ar				Ar	

Synchronization	Timing
No synchronization (both channels running)	2T
Primary channel synchronization (auxiliary channel not running)	4T
Auxiliary channel synchronization (primary channel not running)	4T
Primary and auxiliary channel synchronization (both channels running)	2T + 2

Legend:

- T = Number of transfers
- R = Single-cycle reads primary channel
- R' = Single-cycle reads auxiliary channel
- W = Single-cycle writes primary channel
- W' = Single-cycle writes auxiliary channel
- Pr = Primary channel flag reset (2 cycles)
- Ar = Auxiliary channel flag reset (2 cycles)

Communication Ports

The 'C4x offers six ('C40) or four ('C44) on-chip communication ports for interfacing with other 'C4xs and peripherals. One important feature of the ports is that they can work with the DMA coprocessor to transfer data without CPU intervention, allowing the CPU to perform other tasks.

This chapter describes the key features, memory map and registers, and operations of the communication ports of the 'C4x digital signal processor.

Topic	Page
12.1 Features	12-2
12.2 Operational Overview	12-3
12.3 Memory Map and Registers	12-7
12.4 Port Arbitration Units (PAUs)	12-11
12.5 Halting of Input and Output FIFOs	12-14
12.6 Coordinating Communication Ports With the CPU and DMA Coprocessor	12-17
12.7 Token Transfer Operation	12-19
12.8 Word Transfer Operation	12-22
12.9 Synchronizers	12-26
12.10 Module Reset	12-29
12.11 Tips for Using Communication Ports	12-32

12.1 Features

Each 'C4x communication port has several key features:

- 160-MB per second bidirectional peak data transfer rates (at 40-ns cycle time)
- Simple processor-to-processor communication via eight data lines and four control lines
- FIFO buffering of all data transfers
- Automatic arbitration and handshaking to ensure communication synchronization
- Synchronization between the CPU or direct-memory access (DMA) coprocessor and the six communication ports via internal interrupts and internal ready signals
- Support of a wide variety of multiprocessor architectures, including rings, trees, hypercubes, bidirectional pipelines, two-dimensional Euclidean grids, hexagonal grids, and three-dimensional grids
- Communication-port software reset ('C40 revisions ≥ 5.0 and 'C44 only)

12.2 Operational Overview

The 'C4x contains six ('C40) or four ('C44) identical high-speed communication ports, each of which provides a bidirectional communication interface to one other 'C4x or external peripheral. Figure 12–1 shows the internal architecture of a single communication port. Each port contains the following components:

- ❑ **Input FIFO channel** — provides an 8-level, 32-bit wide first-in-first-out (FIFO) input buffer that isolates the 'C4x from the port communication data bus and buffers data received from an external device via the bus.
- ❑ **Output FIFO channel** — provides an 8-level, 32-bit wide FIFO output buffer that isolates the 'C4x from the port communication data bus and buffers data to be sent to an external device via the bus.
- ❑ **Port arbitration unit (PAU)** — handles the arbitration tasks associated with the movement of data between a 'C4x and an external device via the port communication data bus. The PAU is described in detail in Section 12.4, *Port Arbitration Units (PAUs)*, on page 12-11.
- ❑ **Communication port control register (CPCR)** — allows you to control the communication port functions and data transfer operations between a 'C4x and an external device via the communication port data bus.
- ❑ **Communication-port software reset register ('C44 and 'C40 rev \geq 5.0)** — allows you to flush the input FIFO and output FIFO levels of a communication port. This is explained in subsection 12.3.4, *Communication Port Software Reset Register*, on page 12-10.

A communication port transmits each of the 32-bit words stored in its output FIFO on a byte-to-byte basis. Because the control and data lines are bidirectional, each 'C4x must have ownership of the communication port data bus before starting a word transfer. A simulated *token* is used to designate bus ownership: the communication port that has the token owns the communication port data bus and can transmit data.

Figure 12–1. Communication Port Block Diagram

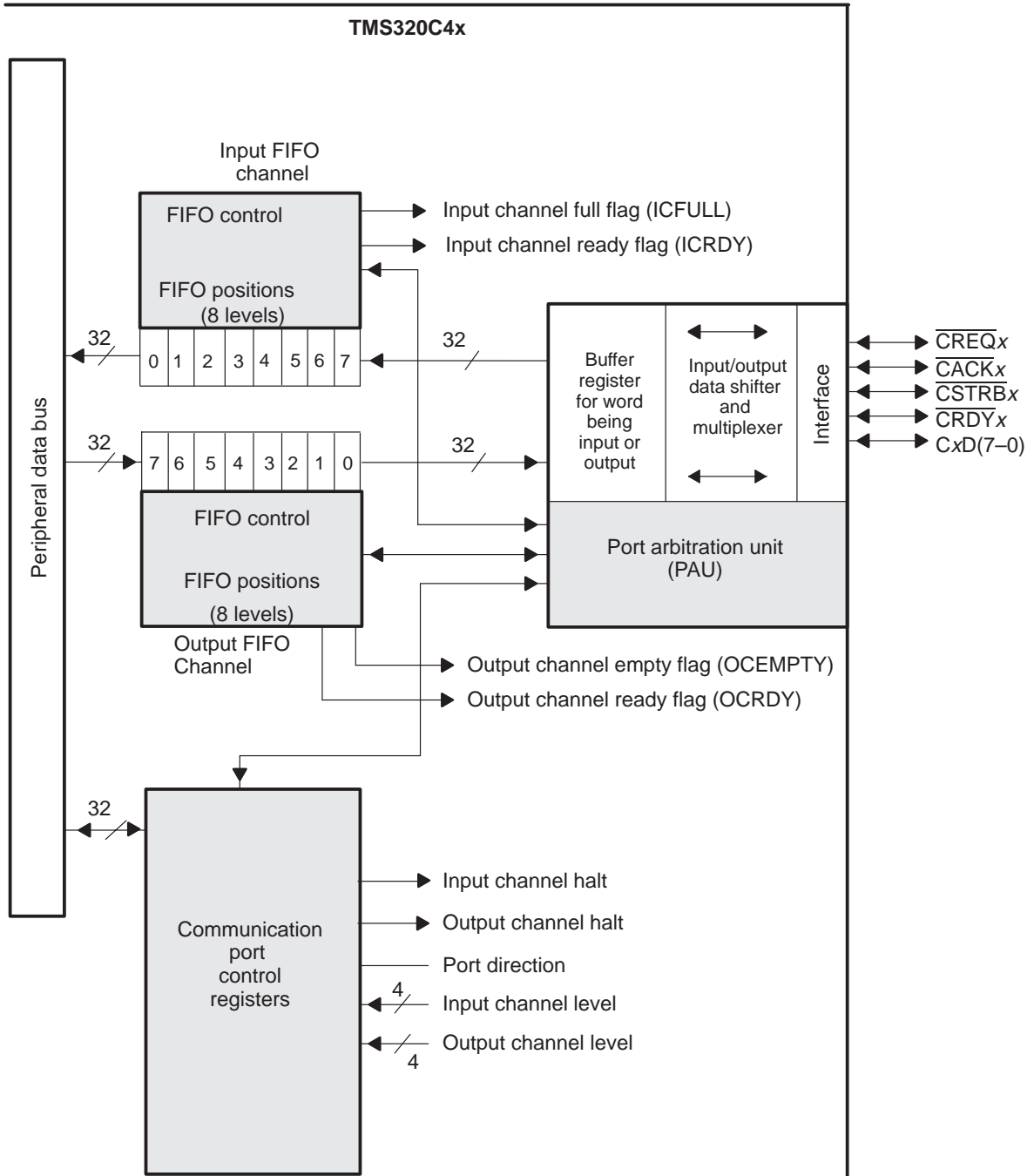

Figure 12–2. 'C4x Communication-Port Interface-Connection Example

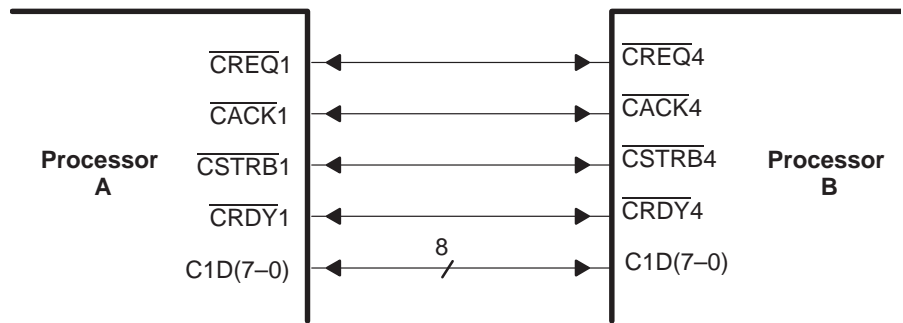

Figure 12–2 is an example of two 'C4x DSPs connected via their communication ports. This simple communication interface consists of the following bidirectional control and data lines:

- $\overline{\text{CREQ}}_x$ — communication-port token request. A 'C4x activates this signal to request the use of the communication-port data bus.
- $\overline{\text{CACK}}_x$ — communication-port token acknowledge. A 'C4x activates this signal to relinquish ownership of the communication-port data bus upon receiving a $\overline{\text{CREQ}}_x$ from another 'C4x.
- $\overline{\text{CSTRB}}_x$ — communication-port strobe. A sending 'C4x activates this signal to indicate that it has placed a valid data byte on the communication port data bus.
- $\overline{\text{CRDY}}_x$ — communication-port ready. A receiving 'C4x activates this signal to indicate that it has received a data byte via the communication port data bus.
- $\text{CxD}(7-0)$ — communication-port data bus. This bus carries data bidirectionally, one byte at a time, between two 'C4xs or between a 'C4x and some other device.

12.2.1 Token Transfer Operation

To transfer a token, the PAUs in the two 'C4xs cooperate to generate the signals and control sequences necessary to ensure orderly data transfers at the highest possible rate. To avoid conflicts on the bus, the PAUs arbitrate bus ownership, allowing only one DSP to transmit at any given time. The PAU that owns the token can relinquish bus ownership when the other 'C4x has data to send.

The signals $\overline{\text{CREQ}}_x$ and $\overline{\text{CACK}}_x$ handle the handshaking arbitration between the two DSPs in two steps:

- 1) The PAU that does not own the data bus (CxD(7–0)) activates $\overline{\text{CREQ}}_x$ to request bus ownership.
- 2) The PAU owning the bus then activates $\overline{\text{CACK}}_x$ to acknowledge the request and relinquish bus ownership to the requesting PAU.

In this manner, these signals transfer a token (or priority) from one PAU to another, and the PAU receiving the token gains ownership of the bus. See Section 12.7, *Token Transfer Operation*, for a detailed description of token transfer.

12.2.2 Data Transfer Operation

A data transfer operation takes four basic steps to complete:

- 1) The CPU or DMA coprocessor of the sending DSP writes a 32-bit data word to the output FIFO (of a communication port) via a memory-mapped address (listed in Figure 12–3).
- 2) The communication port then places the 32-bit data word on CxD(7–0) on a byte-to-byte basis (LS byte first), activating $\overline{\text{CSTRB}}_x$ to signal the receiving communication port that the bus contains a valid data byte.
- 3) Upon receiving each data byte, the receiving communication port activates $\overline{\text{CRDY}}_x$ to indicate that it has received the data byte.
- 4) After receiving the 4 bytes of a 32-bit word, the CPU or DMA coprocessor of the receiving DSP can then read the data from the input FIFO via a memory-mapped address (listed in Figure 12–3).

Each of the input and output FIFOs can buffer a maximum of eight 32-bit words.

Buffering provided by the input and output FIFOs is essential. This buffering allows for a high degree of decoupling of computation and communication overhead. When 'C4xs A and B are connected via their communication ports, the effective length of the FIFOs becomes 16 levels. This occurs because the output path from A to B is the concatenation of the eight levels of the output FIFO of A with the eight levels of the input FIFO of B. This also applies for the output path from B to A.

12.3 Memory Map and Registers

Figure 12–3 shows the memory map for the 'C4x communication-port control registers (CPCRs) and their associated input FIFOs and output FIFOs. The lowest three addresses of each port's 16-address block are mapped to a corresponding CPCr, and its associated input and output FIFOs. Fields (bits) within a CPCr are shown in Figure 12–4.

Figure 12–3. Communication-Port Memory Map

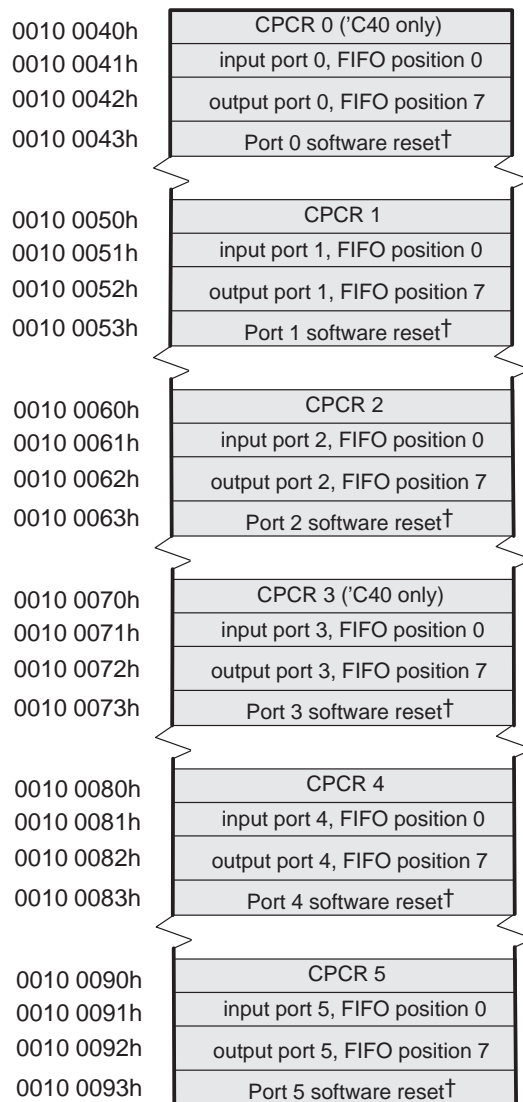

[†] This feature is only available on the 'C44 and on the 'C40 (revision 5.0 and above).

12.3.1 Communication-Port Control Register (CPCR)

Figure 12–4 shows the format of a 'C4x CPCR, which contains control and status bits for its associated communication port. The text following the figure lists the CPCR bits and fields and describes their functions.

Figure 12–4. Communication-Port Control Register (CPCR)

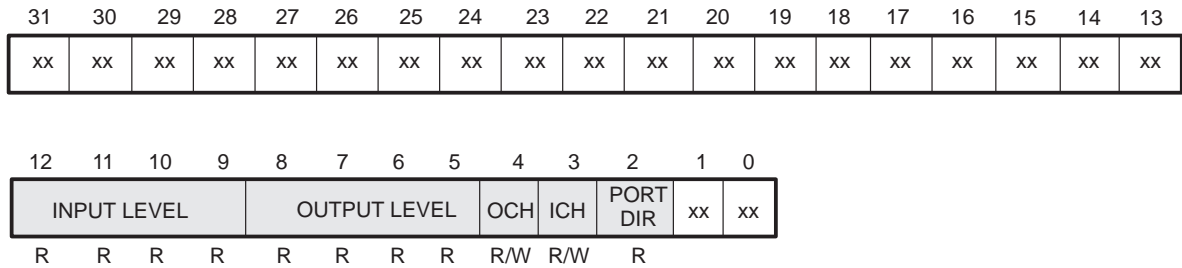

- Notes:**
- 1) xx = reserved bit (read/write as zero).
 - 2) R = read, W = write.

- Reserved** Undefined

- PORT DIR** **Port Direction.** This bit determines the direction of data transfer operations for the communication port.
 PORT DIR = 0: port is in the output mode.
 PORT DIR = 1: port is in the input mode.
 This is a read-only bit. It is not possible to change the port direction under software control.

- ICH** **Input Channel Halt.**
 Write a 1 to ICH to halt the input channel.
 Clear ICH to 0 when the input channel is to be unhalted.
 The input channel cannot signal externally when it is ready to receive.

- OCH** **Output Channel Halt.**
 Write a 1 to this bit to halt the output channel immediately.
 However, the communication port is still able to accept a token request from the input channel.
 Clear this bit to 0 to allow the output channel to transfer data.

OUTPUT LEVEL	<p>Output FIFO Level. Contents of this 4-bit field:</p> <p>0000₂ (0): indicates an empty output FIFO.</p> <p>0001₂ (1) through 0111₂ (7): indicates the number of full positions in the output FIFO.</p> <p>1111₂ (15): indicates a full output FIFO.</p> <p>An empty output buffer (OUTPUT LEVEL = 0000₂) sends an unlatched, positive level-triggered interrupt (OCEMPTY = 1) to the CPU. When the CPU or DMA coprocessor writes to the empty output FIFO, OCEMPTY is cleared to 0 and remains in that state until the buffer is again empty. An output FIFO with one or more empty levels also sends an unlatched, positive level-triggered interrupt (OCRDY = 1) to the CPU and the DMA coprocessor. This condition causes a READY/NOT READY signal to be generated when the CPU or DMA coprocessor attempts to write to the output FIFO. See Section 12.6, <i>Coordinating Communication Ports With the CPU and DMA Coprocessor</i>, on page 12-17, for details.</p>
INPUT LEVEL	<p>Input FIFO level. Contents of this 4-bit field:</p> <p>0000₂ (0): indicates an empty input FIFO.</p> <p>0001₂ (1) through 0111₂ (7): indicates the number of full positions in the input FIFO.</p> <p>1111₂ (15): indicates a full input FIFO.</p> <p>A full input FIFO (INPUT LEVEL = 1111₂) sends an unlatched, positive level-triggered interrupt (ICFULL = 1) to the CPU. When the CPU or DMA coprocessor reads from the full input FIFO, ICFULL is cleared to 0 and remains in that state until the FIFO is again full. An input FIFO with one or more full levels also an unlatched, positive level-triggered interrupt (ICRDY = 1) to the CPU and the DMA coprocessor. This condition causes a READY/NOT READY signal to be generated when the CPU or DMA coprocessor attempts to read from the input FIFO.</p>
Reserved	Undefined.

12.3.2 Input-Port Register

This read-only register contains the contents of position 0, the oldest value of the input FIFO. If this register is written to, its contents remain unchanged. Reading from an empty input FIFO causes the CPU or DMA operation to stall and to halt the peripheral bus.

12.3.3 Output-Port Register

This write-only register interfaces to position 7 (the newest value) of the output FIFO. If this register is read, its contents remain unchanged, and the value read is undefined.

If an output FIFO that is full is written to, the peripheral-bus interface latches the word, and returns a *not ready* signal. This condition disappears when an empty position appears in the output FIFO and the data on the bus is transferred to the FIFO.

12.3.4 Communication-Port Software Reset Register

The input and output FIFO levels for a communication port can be flushed by writing at least two back-to-back values to its communication-port-software reset address as specified in Table 12–1. The communication port reset feature does not affect the status of the external pins.

Table 12–1. Communication-Port Software Reset Address ('C44 and 'C40 \geq 5.0)

COMMUNICATION PORT	SOFTWARE RESET ADDRESS
0†	0x0100043
1	0x0100053
2	0x0100063
3†	0x0100073
4	0x0100083
5	0x0100093

† These ports are available only in the 'C40.

Example 12–1 shows a method for resetting a communication port.

Example 12–2. Communication Port Reset

```

; -----;
; RESET1: Flushes FIFOs data for communication port 1;
; -----;
RESET1 push  AR0          ; Save registers
      push  R0           ;
      push  RC           ;
      ldhi  010h,AR0     ; Set AR0 to base address of COM 1
      or    050h,AR0     ;
FLUSH: rpts  1           ; Flush FIFO data with back-to-back writes
      sti   R0,*+AR0(3) ;
      rpts  10          ; Wait
      nop                    ;
      ldi   *+AR0(0),R0   ; Check for new data from other port
      and   01FE0h,R0    ;
      bnz   FLUSH        ;
      pop   RC           ; Restore registers
      pop   R0           ;
      pop   AR0         ;
      rets                ; Return

```

12.4 Port Arbitration Units (PAUs)

The PAU arbitrates between two devices to determine which device has possession of the communication port data bus at any given time. This arbitration uses \overline{CREQ} and \overline{CACK} signals to pass the bus ownership token back and forth between two devices connected via their communication ports. Token transfer operation is covered in detail in Section 12.7, *Token Transfer Operation*.

After system reset, half of the communication channels associated with a particular 'C4x have token ownership (communication ports 0, 1, 2), and the other half (communication ports 3, 4, 5) do not.

The PAU is a synchronous state machine with four states, as shown in Table 12–2. These states are not software-accessible by the CPU or the DMA coprocessor.

Table 12–2. PAU State Definitions

PAU State	Summary	PAU Status
State 0: Idle with token	1. PAU has token (PORT DIR = 0). 2. Channel not in use.	The PAU currently has possession of the bus ownership token, and its associated communication channel is not in use. Under this condition, the PORT DIR bit of the associated CPCR is 0 (output). This is the state of communication ports 0, 1, and 2 after system reset.
State 1: Idle without token	1. PAU does not have token (PORT DIR = 1). 2. Token not requested by PAU (OUTPUT LEVEL = 0).	The PAU currently does not have possession of the bus ownership token and has not requested the token. Under this condition, the PORT DIR bit equals 1 (input), and the OUTPUT LEVEL field equals 0 (empty output FIFO). This is the state of communication ports 3, 4, and 5 after system reset.
State 2: Active	1. PAU has token (PORT DIR = 0). 2. Channel is in use (OUTPUT LEVEL \neq 0).	The PAU currently has possession of the bus ownership token, and its associated communication channel is in use. Under this condition, the PORT DIR bit equals 0 (output), and the OUTPUT LEVEL field <i>does not</i> equal 0).
State 3: Waiting for token	1. PAU does not have token (PORT DIR = 1). 2. Token requested by PAU (OUTPUT LEVEL \neq 0).	The PAU currently does not have the bus ownership token but has requested it. Under this condition, the PORT DIR bit equals 1 (input), and the OUTPUT LEVEL field <i>does not</i> equal 0.

Figure 12–5 shows the state diagram and controlling equations for state transitions.

To place data on the communication port data bus, the PAU must arbitrate between two types of requests:

- ❑ On-chip requests to output data in the output FIFO (shown as $BUSRQ = 1$ in Figure 12–5), and
- ❑ External requests received via the \overline{CREQ} line (shown as $TOKRQ = 1$ in Figure 12–5).

Figure 12–5. Communication-Port Arbitration-Unit State Diagram

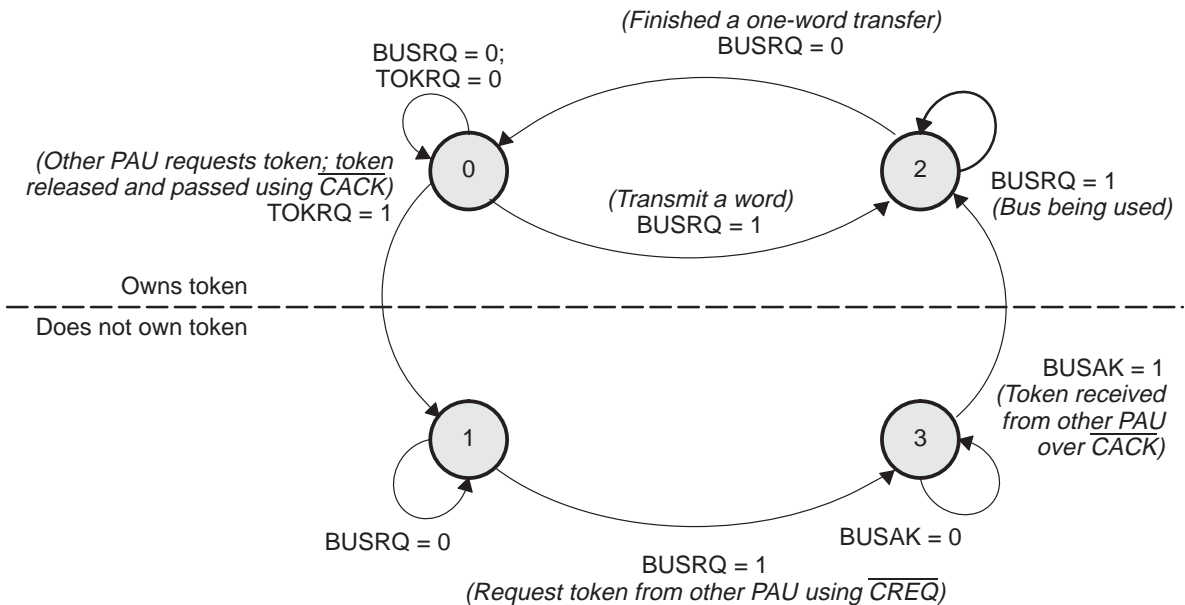

To further examine the port arbitration scheme represented in Figure 12–5, consider a data transfer operation from 'C4x A to 'C4x B. The transfer begins with PAU A in state 0 (idle with token) and PAU B in state 1 (idle without token). If PAU A receives a request ($BUSRQ = 1$) from its output buffer to use the communication-port data bus, it allows the output buffer to transmit one word immediately and enter state 2 (active). After the output buffer transmits one word, it removes the bus request ($BUSRQ = 0$), and PAU A returns to state 0 (idle with token).

If PAU B receives a request from its output buffer to use the bus, it activates $\overline{\text{CREQ}}$ to request the token from PAU A. PAU A detects this request via the state variable TOKRQ=1 and then activates the $\overline{\text{CACK}}$ line to transfer the bus ownership token to PAU B. PAU B then generates an internal bus acknowledge (BUSAK = 1) to indicate that it has gained bus ownership. As a result of this token transfer operation, PAU A enters state 1 (idle without token), and PAU B starts the word transfer and enters state 2 (active).

To prevent any communication port from monopolizing the communication-port bus, the PAU always returns to state 0 (idle with token) and checks for a token request ($\overline{\text{CREQ}}$ active) from the external device after each word transfer. If the token request is active, the token is passed to the requesting device so that it can transmit a word. As long as 'C4x A and 'C4x B have information to send in their output FIFOs, they alternate use of the data bus to provide a bi-directional data path.

If a token request is received at the end of a word transfer and the sender 'C4x has another word in the output FIFO to send, two situations can occur:

- If the $\overline{\text{CREQ}}$ going low signal is received before $\overline{\text{CRDY}}$ low is received for the last byte, the sender 'C4x releases the token at the end of the current word transfer.
- If the $\overline{\text{CREQ}}$ going low signal is received after or at the same time as $\overline{\text{CRDY}}$ goes low from the last byte, the sender 'C4x continues owning the token; only after transferring the next word, will it release token ownership.

In summary, token transfer occurs only on word boundaries. The 'C4x will not release the token until the transfer of the four bytes completes.

12.5 Halting of Input and Output FIFOs

The 'C4x can halt the input FIFO, or the output FIFO, or both at word boundaries.

To halt an input FIFO, write a 1 to bit 3 (ICH) of the communication port control register (CPCR). This bit also can be read to determine if the port is halted or is able to receive. Write a 0 to the ICH bit to unhalt the input FIFO.

To halt an output FIFO, write a 1 to bit 4 (OCH) of the communication port control register (CPCR). This bit also can be read to determine whether the port is halted or is able to transmit. Write a 0 to the OCH bit to unhalt the output FIFO. The halt/unhalt operations are discussed in the following subsections. A summary is provided in Table 12–3.

Table 12–3. Summary of Input and Output FIFO Halting

Halted/Unhalted	If the Port Has Token	If the Port Does Not Have Token
Input halted Output unhalted	a. Will not release token b. Will transmit data	a. If the halt signal is present when the input FIFO finishes receiving a word, the port will not signal ready when the first byte of a new word is received (transfer frozen). If the halt signal is received with no word reception in progress, the port receives one word and then halts. b. If halted after the first byte is received, the port receives the rest of the word and then halts the input.
Input unhalted Output halted	a. Will not transmit data b. If halted after the first byte is sent, it completes the word transfer and then halts the output. c. Will release token	a. Will receive data b. Will not request token
Input halted Output halted	a. Will not release token b. Will not transmit data c. If halted after the first byte is sent, it completes the word transfer and then halts the output	a. If the halt signal is present when the input FIFO finishes receiving a word, the port will not signal ready when the first byte of a new word is received (transfer frozen). If the halt signal is received with no word reception in progress, the port receives one word and then halts. b. If halted after the first byte is received, if the port receives the rest of the word and then halts the input. c. Will not request token

12.5.1 Input FIFO Halt Operation

The goal of input FIFO halting is to halt the input FIFO as soon as possible, without losing the data being input.

A communication port with an input FIFO that is either halted or is full does not respond to $\overline{\text{CSTRB}}$ low with $\overline{\text{CRDY}}$ low or acknowledge a token request with $\overline{\text{CACK}}$ low when $\overline{\text{CREQ}}$ low is received. This assures that the communication port's output channel remains open.

The communication-port logic checks whether an input FIFO halt signal has been written to the CPCR register only after finishing receiving a word. This implies:

- If the communication port receives an input halt signal when there is no word reception in progress, the input FIFO does not halt immediately; it waits to receive one word and then halts. This is the case of an input FIFO halt after reset.
- If the halt signal is written to the CPCR register while a word is being received, the input FIFO receives the rest of the current word and then halts the input. At this point, the data transfer is frozen until the input FIFO is unhalting or a system reset occurs. If the input FIFO is unhalted later, the transfer continues without any loss of data.

Notice that even when an input FIFO is halted, you can still read the words previously stored in the input FIFO.

If a communication port's input FIFO is halted during a token request from the communication port to which it is connected, then the token request is acknowledged before the input FIFO halts.

12.5.2 Output FIFO Halt Operation

Output FIFO halting is analogous to input FIFO halting and occurs also at word boundaries. Assume that 'C4x A's output FIFO has $\text{OCH} = 1$. Then the output FIFO will be halted on the basis of its current state.

If communication port A does not have the token:

- The output FIFO is halted immediately, and no request is made for the token.
- If the communication port requesting the token is halted after sending the CREQ signal low, the communication port still accepts the token and halts immediately after that.

If communication port A has the token:

- If it is currently transmitting a word, then after the current word is transmitted, the output FIFO is halted and no new transfers occur.
- If it is not currently transmitting a word, then the output FIFO halts immediately and no transfer occurs.
- If the input FIFO is not halted and the output FIFO is halted, then communication port A transfers the token when requested by communication port B.
- If the input FIFO is halted and the output FIFO is halted, then communication port A does not transfer the token when requested by communication port B.

If the communication port still has the token when it comes out of the halted state, it can transmit data if necessary. If it needs the token, it will arbitrate for the token as usual.

In summary, a halted output FIFO does not transmit but releases the token if the input FIFO is not halted.

12.6 Coordinating Communication Ports With the CPU and DMA Coprocessor

The communication ports support synchronization with two types of signals:

- A ready/not ready signal that can halt CPU and DMA accesses to a communication port
- Interrupts that can be used to signal the CPU and DMA

The simplest form of synchronization is based on a ready/not-ready signal. If the DMA or CPU attempt to read an empty input FIFO or write to a full output FIFO, a not-ready signal is returned, and the DMA or CPU continues to read or write (halting the peripheral bus) until a ready signal is received. The ready signal for the output channel is OCRDY (output channel ready), which is also an interrupt signal. The ready signal for the input channel is ICRDY (input channel ready), which is also an interrupt signal.

In the interrupt form of synchronization, each communication port generates four different interrupt signals, as listed below (interrupt vector locations for these are shown in Figure 7–2):

- ICFULL (input channel full): indicates that the input FIFO has eight words.
- ICRDY (input channel ready): indicates that at least one word is in the input FIFO.
- OCRDY (output channel ready): indicates that at least one word space is available in the output FIFO.
- OCEMPTY (output channel empty): Indicates that the output FIFO is empty.

The CPU can respond to all four of these interrupt signals. The DMA coprocessor can respond only to the ICRDY and OCRDY interrupt signals. Each DMA channel can respond only to the ICRDY and OCRDY signals coming from its own communication port; that is, DMA channel i can synchronize only with $ICRDY_i$ and $OCRDY_i$.

Notice that none of the four communication-port interrupt signals has flags in the IIF register. These four communication-port status signals (ICFULL, ICRDY, OCRDY, and OCEMPTY) can be obtained by checking the input and output levels in the communication port control register (CPCR) with logical instructions. For example, to poll for an ICFULL condition, bit 12 can be tested for a bit value equal to 1. See subsection 12.3.1, *Communication-Port Control Register (CPCR)*, on page 12-8, for more information about checking for communication-port conditions.

Maximum Communication Port Sustained Transfer Rate. The maximum data transfer rate of any single communication port in a 50-MHz 'C4x is 20 M Bytes/s. This rate can be easily achieved under CPU or DMA coprocessor control, as long as data is sent to the output FIFO at least at this rate. However, when multiple communication ports are transmitting simultaneously, this may not be the case. For example, the DMA memory-to-memory maximum transfer rate is 50 M bytes/s (one read-write sequence every two cycles). The DMA can handle up to two communication ports transmitting at their full speed. For more than two communication ports, the DMA becomes the bottleneck, regardless of how many DMA channels are used. The CPU can perform two reads and two writes in two cycles by using parallel instructions, achieving a 100-M Bytes/s transfer rate. For more than five communication ports, the CPU becomes the bottleneck.

12.7 Token Transfer Operation

Token transfer operation requires handshaking of signals through pins $\overline{\text{CREQ}}$ and $\overline{\text{CACK}}$. This is illustrated in Figure 12–6. For clarity, a suffix identifies the signals at each processor end. For example, $\overline{\text{CREQ}}_b$ denotes the $\overline{\text{CREQ}}$ signal at the processor B end. Table 12–4 lists the handshaking events. Steps in the table are shown by numbers in Figure 12–6.

Notice that an overlap feature is built into $\overline{\text{CREQ}}$, $\overline{\text{CSTRB}}$, and $\overline{\text{CRDY}}$ when a token is transferred between two 'C4x communication ports. This overlap will cause these signals to drive high (at both ends), ensuring that neither end is susceptible to floating or low-noise signals. For example, in Figure 14–23, $\overline{\text{CSTRB}}$ is an output before $\overline{\text{CREQ}}$ goes high, and in Figure 14–24, $\overline{\text{CSTRB}}$ becomes an input only after $\overline{\text{CREQ}}$ goes high. Both 'C4xs drive communication port lines for a period of 0.5 H1/H3, but this is not a problem, because they are both driving high; as a result, there is no current from one device to the other.

For this reason, the clocks of two 'C4xs connected together must be within a 2:1 ratio (at most, one 'C4x can be twice as fast as the other). If this guideline is not followed, the overlap will last too long, and the 'C4x with the faster clock may start driving low before the current bus master has relinquished that line. This will cause signal contention that could damage communication port drivers.

There is no limit on the time period between $\overline{\text{CREQ}}$ and $\overline{\text{CACK}}$. The 'C4x can perform token transfer with a slow non-'C4x device, as long as correct handshaking of $\overline{\text{CREQ}}$ and $\overline{\text{CACK}}$ is maintained and there is no signal contention.

To avoid bus contention problems, you should understand which event triggers the switch of the direction (input-to-output or output-to-input) of each of the communication port bidirectional lines. This is especially important when you attempt to build a communication port interface to a non-'C4x device or when you work with very long 'C4x links. For example, the data lines and $\overline{\text{CSTRB}}$ should not be driven after $\overline{\text{CACK}}$ goes low. If they are, this could cause a bus conflict.

An implementation of a hardware token forcer can be found in the *Communication Ports* chapter of the *TMS320C4x General-Purpose Applications User's Guide*.

Figure 12–6. Token Transfer Operation

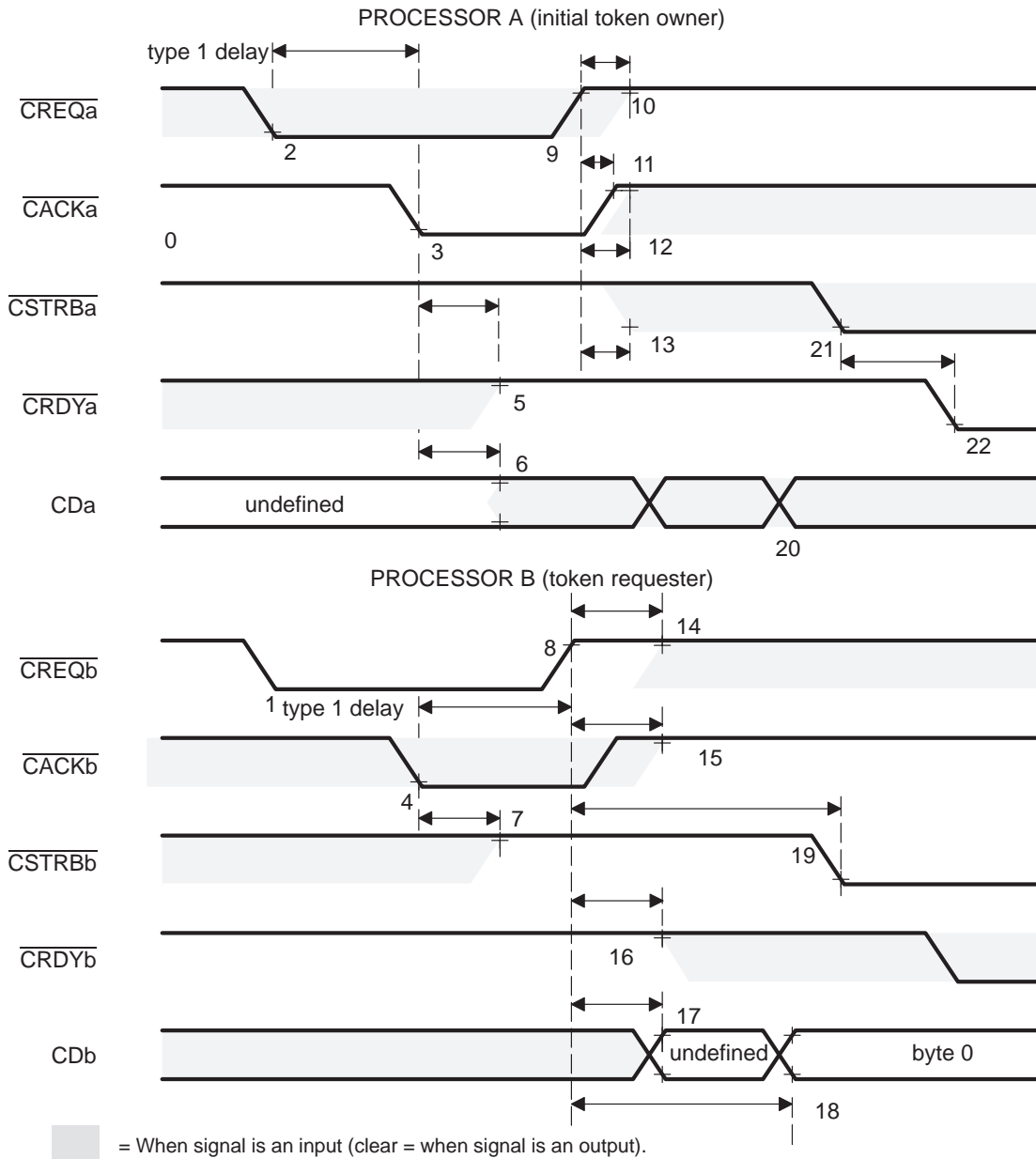

Note: For an explanation of Type 1 delay, see Section 12.9, *Synchronizers*.

Table 12–4. Token Transfer Sequence

Event No.†	Description
0	Initially, A has the token and is idle.
1	B wants to send data and requests the token by bringing $\overline{\text{CREQb}}$ low.
2	After a transmission line time delay, A sees the token request when $\overline{\text{CREQa}}$ goes low.
3	After a type 1 delay from $\overline{\text{CREQa}}$ falling, A releases token ownership and acknowledges the request by bringing $\overline{\text{CACKa}}$ low.
4	After a transmission line time delay, B sees the acknowledgement from A when $\overline{\text{CACKb}}$ goes low.
5	A switches $\overline{\text{CRDYa}}$ from high impedance to high after $\overline{\text{CACKa}}$ falling.
6	A puts $\text{CDa}(7-0)$ in high impedance after $\overline{\text{CACKa}}$ falling.
7	B switches $\overline{\text{CSTRBb}}$ from high impedance to high after $\overline{\text{CACKb}}$ falling.
8	B brings $\overline{\text{CREQb}}$ high after a type 1 delay from $\overline{\text{CACKb}}$ falling.
9	After a transmission line time delay, A sees $\overline{\text{CREQa}}$ go high.
10	A switches $\overline{\text{CREQa}}$ from high impedance to high after receiving a high on $\overline{\text{CREQa}}$.
11	A brings $\overline{\text{CACKa}}$ high after $\overline{\text{CREQa}}$ goes high.
12	A puts $\overline{\text{CACKa}}$ in high impedance after $\overline{\text{CREQa}}$ goes high and after $\overline{\text{CACKa}}$ goes high.
13	A puts $\overline{\text{CSTRBa}}$ in high impedance after $\overline{\text{CREQa}}$ goes high.
14	B puts $\overline{\text{CREQb}}$ in high impedance after $\overline{\text{CREQb}}$ goes high.
15	B switches $\overline{\text{CACKb}}$ from high impedance to high after $\overline{\text{CREQb}}$ goes high.
16	B puts $\overline{\text{CRDYb}}$ in high impedance after $\overline{\text{CREQb}}$ goes high.
17	B switches CDb from input to output after $\overline{\text{CREQb}}$ goes high and starts driving an undefined value.
18	B drives the first byte onto $\text{CDb}(7-0)$ on H1 rising (plus analog delay) after $\overline{\text{CREQb}}$ goes high.
19	B brings $\overline{\text{CSTRBb}}$ low on the second H1 rising (plus analog delay) after $\overline{\text{CREQb}}$ rising.
20	After a transmission time delay, A sees the first byte on $\text{CDa}(7-0)$.
21	After a transmission time delay, A sees $\overline{\text{CSTRBa}}$ go low, signaling valid data.
22	A reads the data and then brings $\overline{\text{CRDYa}}$ low.

† Event numbers correspond to numbers in Figure 12–6.

12.8 Word Transfer Operation

The C4x communication ports transfer words on a byte-to-byte basis (LS byte is transmitted first). Byte transfer operation requires handshaking of signals through pins $\overline{\text{CSTRB}}$ and $\overline{\text{CRDY}}$. This is illustrated in Figure 12–7. For clarity, a suffix identifies the signals at each processor end. For example, $\overline{\text{CSTRB}}_b$ denotes the $\overline{\text{CSTRB}}$ signal at the processor B end. Table 12–5 lists the handshaking events. Steps in the table are shown by numbers in Figure 12–7.

Byte transmission is totally asynchronous, and the communication-port transfer rate can be higher than one byte per cycle. The exception is for the first byte. Notice that on the first byte, the data lines are set up in relation to an H1 synchronization (output FIFO advance). The first byte appears on a different H1 edge, depending on the transmit mode used. If the communication port is in continuous transmit mode (no token exchanged), the first data byte appears synchronous to the H1 falling edge before $\overline{\text{CSTRB}}$ going low. That is, the data appears one half of one H1 cycle before $\overline{\text{CSTRB}}$ falls. If a token transfer occurs, the first byte appears synchronous to the rising edge of H1 before $\overline{\text{CSTRB}}$ going low. That is, data appears one H1 cycle before $\overline{\text{CSTRB}}$ falls.

Subsequent bytes and $\overline{\text{CSTRB}}$ high become valid from the falling edge of $\overline{\text{CRDY}}$. Because both of these signals are caused by the same event but have different internal paths, their delay values are not exactly the same but are very close.

During back-to-back write cycles, a type 2 synchronizer is used between $\overline{\text{CRDY}}$ low to $\overline{\text{CSTRB}}$ low before byte 0 (first byte) of the next word is transmitted. Communication port synchronizers are explained in Section 12.9, *Synchronizers*, on page 12-26.

Even if the availability of data is granted, do not tie $\overline{\text{CSTRB}}$ or $\overline{\text{CRDY}}$ to ground. For each byte transfer, there must be a $\overline{\text{CSTRB}}$ and $\overline{\text{CRDY}}$ handshake. The 'C4x must see the transitions in the $\overline{\text{CSTRB}}$ and $\overline{\text{CRDY}}$ signals to advance its internal byte counter.

If an input buffer becomes full, it will not activate $\overline{\text{CRDY}}$ at the beginning of the transmission of the first byte that would overflow the buffer. This condition prevents data transfer operations until the situation is resolved. When the receiver reads the full input buffer, $\overline{\text{CRDY}}$ falls, and the next FIFO position is made available.

Notice in Figure 12–7 that after $\overline{\text{CRDY}}_b$ goes low (byte 3 has been received), B drives an undefined value temporarily on CD_b (7–0) (event 12 in Figure 12–7) before driving byte 0 of the new word.

Figure 12–7. Word Transfer Operation

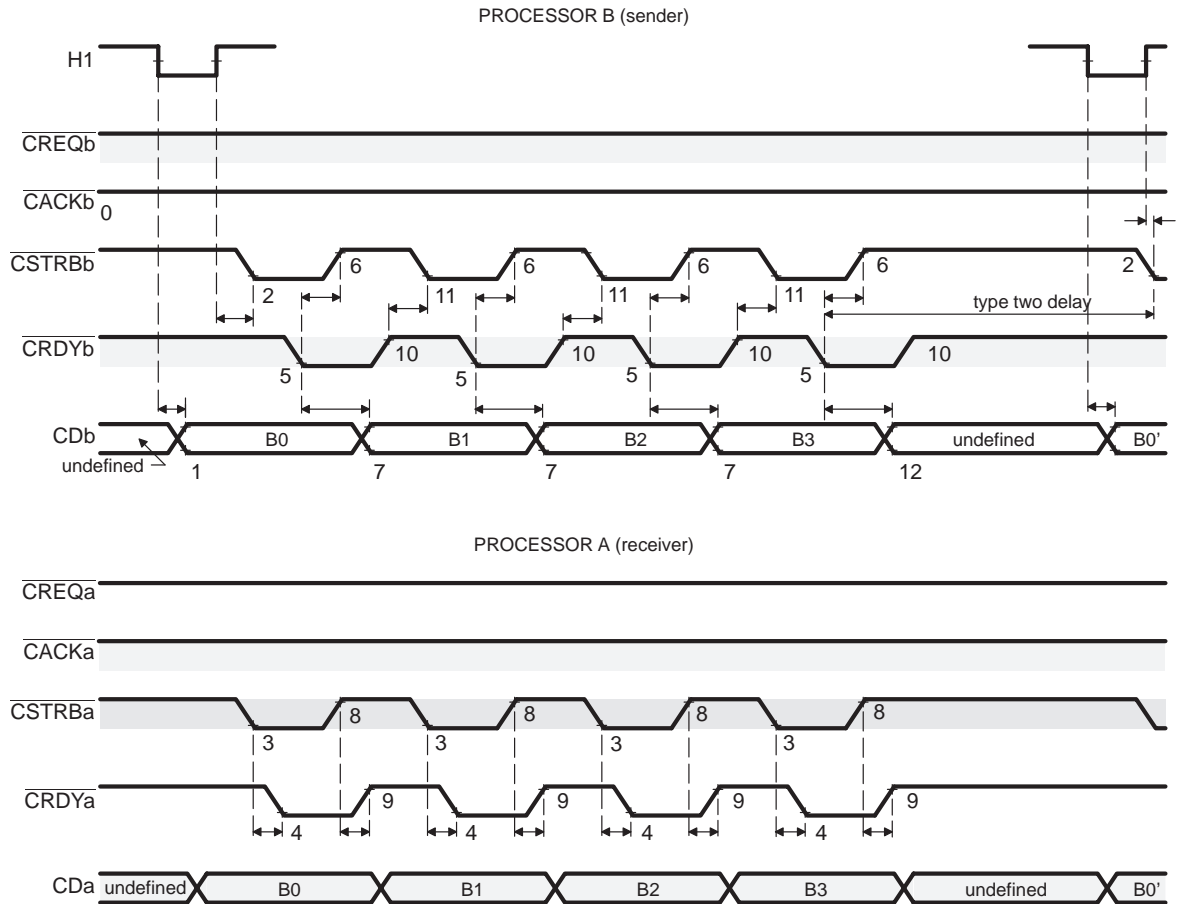

 = When signal is an input (clear = when signal is an output).

Note: B0' = byte 0 of a new word.

Table 12–5. Word Transfer Sequence

Event No.†	Description
0	B owns the token and has data to transmit.
1	B drives the first byte onto CDb(7–0) on H1 falling (plus analog delay)‡.
2	B brings $\overline{\text{CSTRBb}}$ low on H1 rising (plus analog delay)§.
3	After a transmission line time delay, A sees $\overline{\text{CSTRBa}}$ go low, signaling valid data.
4	A reads the data and then brings $\overline{\text{CRDYa}}$ low
5	After a transmission line time delay B sees $\overline{\text{CRDYb}}$ go low, signaling data has been read.
6	B brings $\overline{\text{CSTRBb}}$ high after $\overline{\text{CRDYb}}$ goes low.
7	B drives the next byte on CDb(7–0) after $\overline{\text{CRDYb}}$ goes low.
8	After a transmission line time delay, A sees $\overline{\text{CSTRBa}}$ go high.
9	A brings $\overline{\text{CRDYa}}$ high after $\overline{\text{CSTRBa}}$ goes high.
10	After a transmission line time delay, B sees $\overline{\text{CRDYb}}$ go high.
11	B brings $\overline{\text{CSTRBb}}$ low after $\overline{\text{CRDYb}}$ goes high.
	Events 3 through 11 repeat twice for bytes 2 and 3 (asynchronous handshaking)
12	B drives an undefined byte on CDb(7–0) after $\overline{\text{CRDY}}$ goes low.

† Event numbers correspond to numbers in Figure 12–7.

‡ If this is the first word the token is received, this transition occurs after $\overline{\text{CREQb}}$ goes high (See event 18 in Table 12–4).

§ If this is the first word after the token is received, this transition occurs on the second H1 rising after $\overline{\text{CREQb}}$ goes high (See event 19 in Table 12–4).

CSTRB Width Restrictions

In 'C4x device revisions lower than 3.0, the width of the $\overline{\text{CSTRB}}$ low pulse between word boundaries should not exceed 1.0 H1/H3 at the receiving 'C4x end. If it does, the receiver 'C4x byte counter that has looped back to byte 0 between word boundaries will see this low and recognize $\overline{\text{CSTRB}}$ as the next valid byte, effectively slipping a byte. This is not a problem unless you are working with very long distances or with external devices. If you are, use flip-flops to locally shorten the $\overline{\text{CSTRB}}$ at the receiver end while returning a valid $\overline{\text{CRDY}}$ width to the sender. Wide widths at the sender are not a problem. Chapter 7, *Interfacing Communication Ports*, the *TMS320C4x General-Purpose Applications User's Guide* shows a circuit to shorten the $\overline{\text{CSTRB}}$ low pulse. In 'C4x device revisions 3.0 or higher, no $\overline{\text{CSTRB}}$ width restriction exists.

Note:

See Chapter 7, *Interfacing Communication Ports*, in the *TMS320C4x General-Purpose Applications User's Guide* for a detailed description of the word transfer operation when interfacing a 'C4x communication port with a non-'C4x device.

12.9 Synchronizers

H1/H3 synchronization is required during word transfer boundaries and during token transfers. Three types of synchronizers are used in the port arbitration unit:

- **Type-one synchronizers** cause delays that vary from 1 to 2 machine clock from the receiving of an input on a pin until the response on output pin (ignoring analog delays). An input is recognized when H1 is high; then it is passed through an *H3-high/H1-high* series of delays. The response occurs at the start of the following time H3 is high.

The minimum type-one synchronizer delay of 1 machine clock will occur when the input changes just before H1 goes low. This delay is shown in Figure 12–8.

The maximum type-one synchronizer delay of 2 machine clocks will occur when the input changes just after H1 goes low. This delay is shown in Figure 12–9.

Figure 12–8. Type-One Synchronizer Minimum Delay

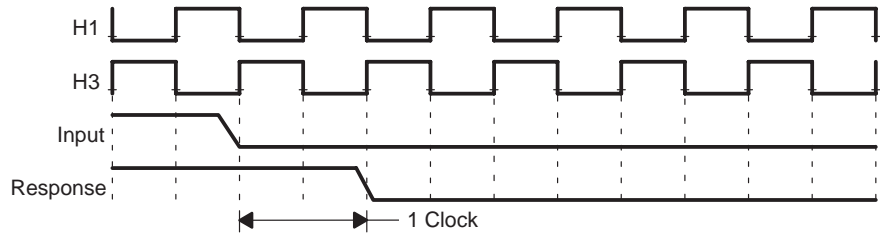
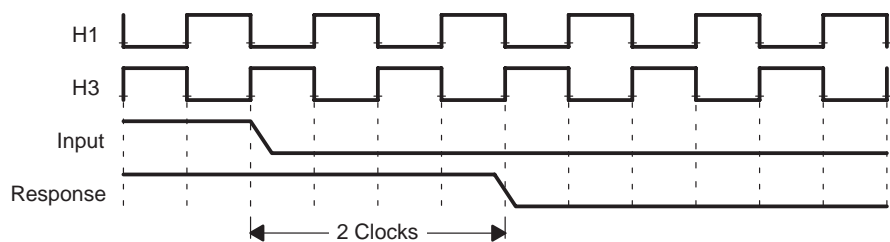

Figure 12–9. Type-One Synchronizer Maximum Delay



- **Type-two synchronizers** cause delays that vary from 1.5 to 2.5 machine clock from the receiving of an input on a pin until the response on an output pin (ignoring analog delays). An input is recognized when H1 is high; then it is passed through an *H3-high/H1-high/H3-high* series of delays. The response occurs at the start of the following time H1 is high.

The minimum type-two synchronizer delay of 1.5 machine clocks occurs when the input changes just before H1 goes low. This delay is shown in Figure 12–10.

The maximum type-two synchronizer delay of 2.5 machine clocks occurs when the input changes just after H1 goes low. This delay is shown in Figure 12–11.

Figure 12–10. Type-Two Synchronizer Minimum Delay

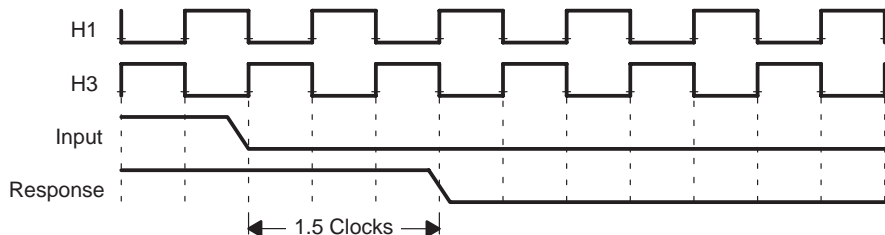
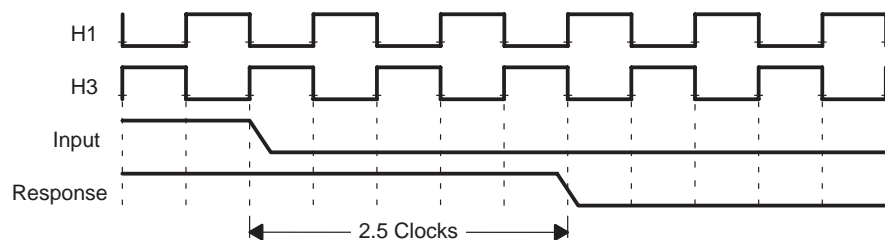

Figure 12–11. Type-Two Synchronizer Maximum Delay



- **Type-three synchronizers** cause delays that vary from 0.5 to 1.5 machine clocks from the receiving of an input on a pin until the response on output pin (ignoring analog delays). An input is recognized when H1 is high; then it is passed through an *H3-high* delay. The response occurs at the following time H1 is high.

The minimum type-three synchronizer delay of 0.5 machine clock cycles will occur when the input changes just before H1 goes low. This delay is shown in Figure 12–12.

The maximum type-three synchronizer delay of 1.5 machine clocks will occur when the input changes just after H1 goes low. This delay is shown in Figure 12–13.

Figure 12–12. Type-Three Synchronizer Minimum Delay

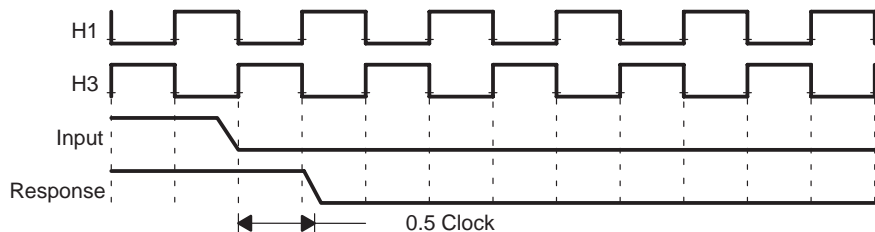

Figure 12–13. Type-Three Synchronizer Maximum Delay

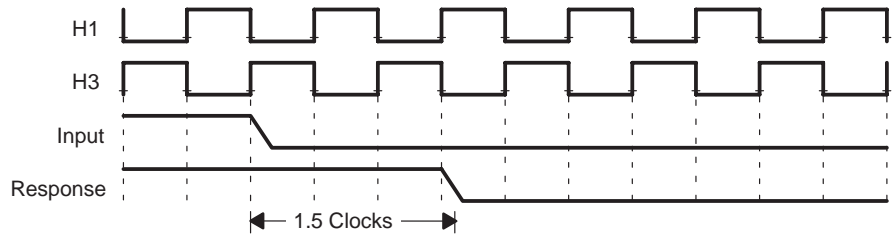

Table 12–6 shows the types of synchronizer delays for communication port signals.

Table 12–6. Communication-Port Signals and Synchronizer Delays

Input Signal to Output Signal	Delay Type	Min. Delay (clock cycles)	Max. Delay (clock cycles)
$\overline{\text{CREQ}}\downarrow$ to $\overline{\text{CACK}}\downarrow$	One	1	2
$\overline{\text{CACK}}\downarrow$ to $\overline{\text{CREQ}}\uparrow$	One	1	2
$\overline{\text{CRDY}}\downarrow$ to CD valid between back-to-back word transfers	One	1	2
$\overline{\text{CRDY}}\downarrow$ to $\overline{\text{CSTRB}}\downarrow$ between back-to-back word transfers	Two	1.5	2.5
$\overline{\text{CACK}}\downarrow$ to $\overline{\text{CSTRB}}$ switch from input to an output high.	Three	0.5	1.5

12.10 Module Reset

This section explains the status of the 'C4x communication ports after power-up and during and after system reset.

The recommended reset sequence in a multiprocessing system is described in Chapter 1, *Processor Initialization and Program Control*, in the *TMS320C4x General-Purpose Applications User's Guide*.

After powerup, the status depends on the $\overline{\text{RESET}}$ pin:

If $\overline{\text{RESET}}$ is low, the 'C4x is in reset immediately, and the description under "at reset" (below) applies.

If $\overline{\text{RESET}}$ is not low, the 'C4x device is in an unknown stage. The communication port signals can be in a combination of states.

At reset (while $\overline{\text{RESET}} = 0$), the communication port pins are all put in the high-impedance state. The input and output channels both assume an empty state, causing all values in the input and output buffers to be lost. Pullup resistors should be used on all control lines to ensure that they are logic high if reset is not applied at the same time in interconnected 'C4xs.

After reset (after the rising edge of $\overline{\text{RESET}}$), communication ports 0, 1, and 2 are configured as output ports and assume the following states:

- The PAU is reset to state 0: The PAU has the bus ownership token and is idle.
- The pin status (see Figure 12–14) is set as follows:
 - The CxD(7–0) signals start driving an undefined value.
 - The $\overline{\text{CACK}}$ and $\overline{\text{CSTRB}}$ signals go to 1 (inactive). $\overline{\text{CREQ}}$ and $\overline{\text{CRDY}}$ continue to be high-impedance.

Note:

The individual communication port software reset feature only flushes the FIFOs, but does not have any effect on the communication port external pins.

- The communication port control register gets a 0h value:
 - PORT DIR = 0: the communication port is configured for an output operation.
 - INPUT LEVEL = 0: The input FIFO is empty.
 - OUTPUT LEVEL = 0: The output FIFO is empty.
 - ICH = 0: The input FIFO is not in its halted state.
 - OCH = 0: The output FIFO is not in its halted state.
- ICRDY = 0: The input FIFO is empty and is not ready to be read from.
- OCRDY = 0: The input FIFO is not full and is ready to be written to.

Figure 12–14. Post-Reset State for an Output Port

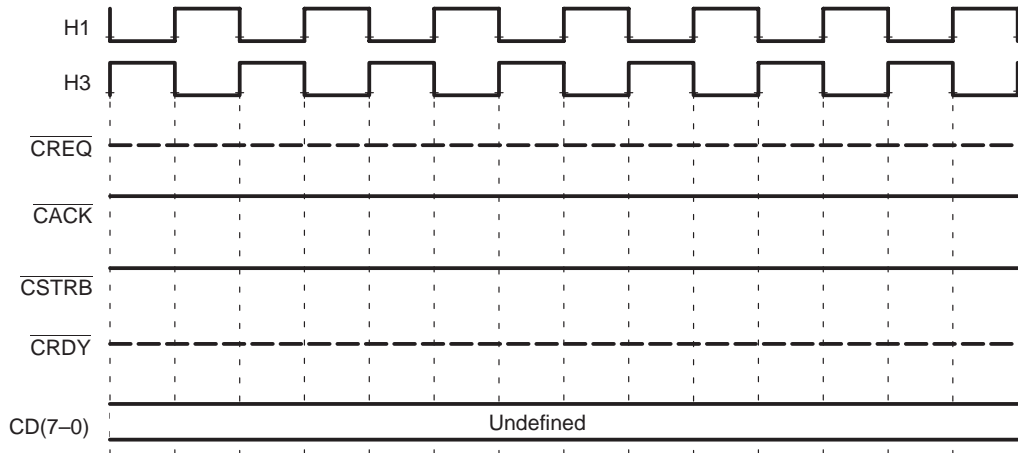

After reset (after rising edge of $\overline{\text{RESET}}$), communication ports 3,4, and 5 are configured as input ports and assume the following states:

- PAU is reset to state 1: The PAU does not have the bus ownership token, and the token is not requested.
- The pin status (see Figure 12–15) is set as follows:
 - CxD(7–0) continue to be high-impedance.
 - $\overline{\text{CREQ}}$ and $\overline{\text{CRDY}}$ signals go to 1 (inactive). $\overline{\text{CACK}}$ and $\overline{\text{CSTRB}}$ continue in high impedance.
- The communication port control register gets a value of 04h.

- PORT DIR = 1: the communication port is configured for an input operation:
 - INPUT LEVEL = 0: The input FIFO is empty.
 - OUTPUT LEVEL = 0: The output FIFO is empty.
 - ICH = 0: The input FIFO is not in its halted state.
 - OCH = 0: The output FIFO is not in its halted state.
- ICRDY = 0: The input FIFO is empty and is not ready to be read from.
- OCRDY = 0: The input FIFO is not full and is ready to be written to.

Figure 12–15. Post-Reset State for an Input Port

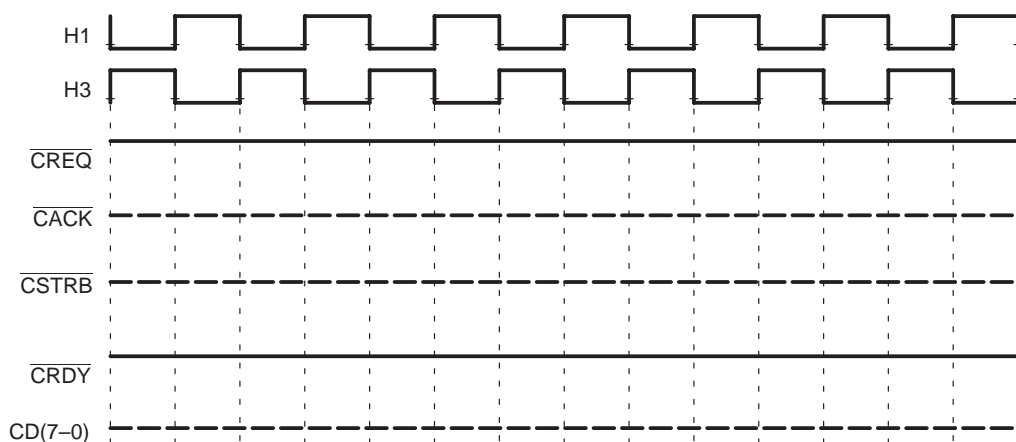

At reset, ports 0, 1, and 2 are configured as output ports (PORT DIR = 0), and ports 3, 4, and 5 are configured as input ports (PORT DIR = 1). When you interconnect the ports of two 'C4x devices, connect the port of one 'C4x to a port of the other 'C4x that would be in the *opposite* direction at reset in other words, connect any one of port 0, 1, or 2 connected to any one of port 3, 4, or 5.

If your system configuration requires connection of input-to-input communication ports or output-to-output communication ports, refer to Chapter 7, *Interfacing Communication Ports*, in the *TMS320C4x General-Purpose Applications User's Guide* for an implementation of a token forcer.

12.11 Tips for Using Communication Ports

When you design systems that use the communication ports, there are considerations to keep in mind:

- ❑ At reset, ports 0–2 are set for transmit and ports 3–5 are set for receive. When connecting communication ports between 'C4x devices, make sure you connect transmit ports to receive ports and receive ports to transmit ports. Otherwise, unpredictable results may occur.
- ❑ Signal quality is very important. Make sure you design your board to minimize noise from other components. See the section entitled *Signal Considerations* in the communications port chapter of the *TMS320C4x General-Purpose Applications User's Guide* for more information.
- ❑ Do not read from an empty input FIFO. This will cause the CPU or DMA operation to stall and to halt the peripheral bus.
- ❑ Do not write to an unconnected communication port. If a port's transmit FIFO is full and the port can't transmit, an additional write to the port's FIFO will halt the peripheral bus.
- ❑ The clocks of two 'C4xs connected together must be within a 2:1 ratio (at most, one 'C4x can be twice as fast as the other). If this guideline is not followed, the 'C4x with the faster clock may start driving low before the current bus master has relinquished that line. This will cause signal contention that could damage communication port drivers. This restriction does not apply when connecting to a non-'C4x device.
- ❑ When you design an interface to a non-'C4x device, the non-'C4x device should mimic the asynchronous handshaking operation of a 'C4x communication port. See *Word Transfer Considerations* in the *TMS320C4x General-Purpose Applications User's Guide* for more information on interfacing to non-'C4x devices.

Note:

See Section 7.4, *Design Tips*, in the *TMS320C4x General-Purpose Applications User's Guide* for more tips for using communication ports.

Timers

The 'C4x has two general-purpose timer modules that time events, generate pulses, and interrupt the CPU or DMA coprocessor.

This chapter provides you with information about:

- The components of the timers
- The control registers of the timers
- The operation of the timers
- The interrupts generated by the timers

Topic	Page
13.1 Overview of the Timers :	13-2
13.2 Timer Pins :	13-4
13.3 Timer Control Registers :	13-5
13.4 Timer Pulse Generation :	13-9
13.5 Timer Interrupts :	13-11
13.6 Selecting CLKSRC and FUNC Values :	13-13
13.7 Using TCLKx as General-Purpose I/O Pins :	13-15
13.8 Configuring a Timer :	13-16

13.1 Overview of the Timers

The 'C4x has two 32-bit general-purpose timer modules. Each timer has two signaling modes and can be clocked by an internal or an external source. The timer modules can be used to send periodic signals to the 'C4x or to devices in the external world; or they can be used to count external events. Each timer has an I/O pin (TCLK) that functions as an input clock, as an output clock, or as a general-purpose I/O pin.

With an internal clock, for example, the timer can signal an external A/D converter to start a conversion, or it can interrupt the 'C4x DMA controller to begin a data transfer.

With an external clock, for example, the timer can count external events and interrupt the CPU after a specified number of events.

Each timer consists of a 32-bit counter, a comparator, an input clock selector, a pulse generator, and supporting hardware.

A timer in the 'C4x counts the cycles of a timer input clock. When that count (counter register) equals the value stored in the timer period register, it rolls over the counter to zero and produces a transition in the timer output signal.

The timer input clock can be either the H1/2 internal clock frequency of the 'C4x or an external clock on the TCLKx pin. This is determined by the CLKSRC bit in the timer control register. If an external clock is used, the timer can counter either 0-to-1 or 1-to-0 transitions depending on the value of the INV bit.

The timer output signal depends on the signalling mode selected by the C/P bit (clock or pulse mode). See Section 13.4, *Timer Pulse Generation*, on page 13-9, for more information about this bit.

The timer output can be routed to the TCLKx pin that can also be used as a general-purpose I/O pin.

Figure 13–1 shows the block diagram of a 'C4x timer module.

Figure 13–1. Timer Block Diagram

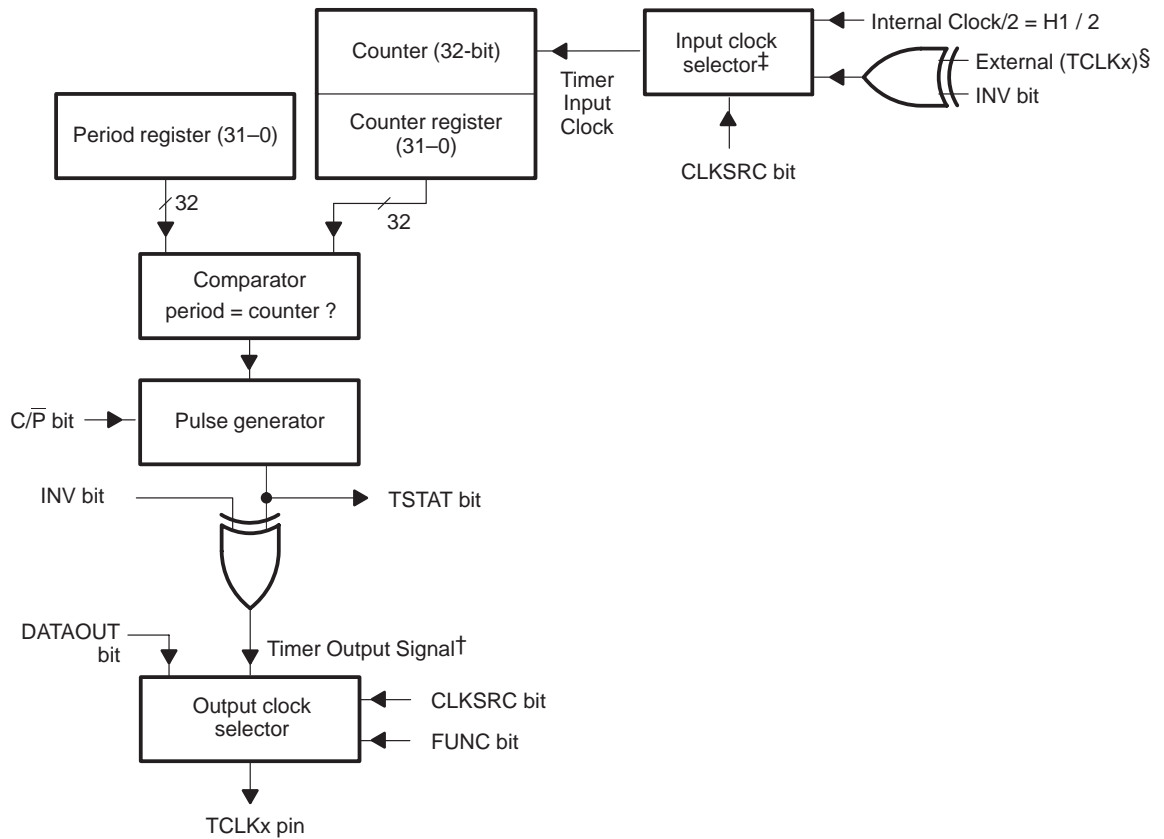

† If $CLKSRC = 1$ and $FUNC = 1$, this signal goes into the TCLK pin.

‡ Selector controlled by the $CLKSRC$ bit.

§ Maximum frequency = $f(H1) / 2.6$

13.2 Timer Pins

Each timer has one pin associated with the timer clock signal (TCLK) pin.

- **TCLK.** This pin is used as a general-purpose I/O signal, as a timer output, or as an input for an external clock for a timer. Each timer has a TCLK pin: TCLK0 is connected to timer 0 and TCLK1 is connected to timer 1.

13.3 Timer Control Registers

The timers are controlled through three registers, as shown in Figure 13–2, that are mapped into the peripheral address space:

- ❑ **Control register.** This register determines the operating mode of the timer, monitors the timer status, and controls the function of the I/O pin (TCLK) of the timer.
- ❑ **Period register.** This register contains the number of timer input clock cycles to count. This number controls the timer output signal frequency.
- ❑ **Counter register.** Contains the current value of the incrementing counter. The 32-bit counter counts timer input clock cycles.

Figure 13–2. Memory-Mapped Timer Locations

Register	Peripheral Address	
	Timer 0	Timer 1
Timer Control	100020h	100030h
Reserved	100021h	100031h
Reserved	100022h	100032h
Reserved	100023h	100033h
Timer Counter	100024h	100034h
Reserved	100025h	100035h
Reserved	100026h	100036h
Reserved	100027h	100037h
Timer Period	100028h	100038h
Reserved	100029h	100039h
Reserved	10002Ah	10003Ah
Reserved	10002Bh	10003Bh
Reserved	10002Ch	10003Ch
Reserved	10002Dh	10003Dh
Reserved	10002Eh	10003Eh
Reserved	10002Fh	10003Fh

13.3.1 Timer Control Register

The timer control register is located at 100020h for timer 0 and at 100030h for timer 1.

The 32-bit timer global control register contains two sets of bits:

- The timer global control bits (bits 11–6) control timer mode and monitor timer status (TSTAT).
- The TCLK pin control bits (bits 3–0) control the function of the TCLK pin, which can be used as a timer pin or as a general-purpose I/O pin.

Figure 13–3 shows the 32-bit timer global control register. Note that at reset all bits are set to 0, except for DATIN, which is set to the value read on TCLK.

Figure 13–3. Timer Control Register

32	12	11	10	9	8	7	6	5	4	3	2	1	0
xx	TSTAT	INV	CLKSRC	C/P	HLD	GO	xx	DATIN	DATOUT	I/O	FUNC		
	R/W	R/W	R/W	R/W	R	R		R	R	R	R		

Note: R=Read, W=Write

- FUNC** **Function bit.** The FUNC bit controls the function of the TCLK pin. If FUNC = 0, TCLK is configured as a general-purpose digital I/O pin. If FUNC = 1, TCLK is configured as a timer pin.
- I/O** **Input/output bit.** If I/O = 1 and FUNC = 0, then TCLK is configured as an input pin. If I/O = 0 and FUNC = 0, then TCLK is configured as an output pin.
- DATOUT** **Data output bit.** DATOUT drives TCLK when the 'C4x is in I/O port mode. DATOUT can also be used as an input to the timer.
- DATIN** **Data input bit.** Reads data from TCLK or DATOUT. A write to this bit has no effect.
- GO** **GO bit.** Resets and starts the timer counter. When GO = 1 and the timer is not held, the counter is zeroed and begins incrementing on the next rising edge of the timer input clock. The GO bit is cleared on the same rising edge. When GO = 0, the timer is not affected. Section 13.8, *Configuring A Timer*, further defines this bit.
- HLD** **Counter hold bit.** When HLD = 0, the counter is disabled and held in its current state. If the timer is driving TCLK, the state of TCLK is also held. The internal divide-by-two counter is also held so that the counter can continue where it left off when HLD is set to 1. The timer registers can be read and modified while the timer is being held. $\overline{\text{RESET}}$ has priority over HLD. Section 13.8, *Configuring A Timer*, shows the effect of writing to GO and HLD, and shows the result of a write using specified values of the GO and HLD bits in the timer global control register.

GO (Bit 6)	HLD (Bit 7)	Result
0	0	All timer operations are held. No reset is performed.
0	1	Timer proceeds from state before write.
1	0	All timer operations are held, including zeroing of the counter. The GO bit is not cleared until the timer is taken out of hold.
1	1	Timer resets and starts.

C/P **Clock/pulse mode control.** When $C/\overline{P} = 1$, clock mode is chosen, and the signaling of the TSTAT status bit and TCLK pin will have a 50 percent duty cycle. When $C/\overline{P} = 0$, the TSTAT status bit and TCLK pin will be active for one H1 cycle during each timer period (see Figure 13–4).

CLKSRC **Timer input clock source select bit.** Specifies the source of the timer input clock. When $CLKSRC = 1$, an internal clock with frequency equal to one-half the H1 frequency is used as the timer input clock, and the INV bit has no effect. When $CLKSRC = 0$, an external signal from the TCLK pin is used as the timer input clock. The external clock is synchronized internally, thus allowing external asynchronous clock sources that do not exceed the specified maximum allowable external clock frequency of $f(H1)/2.6$.

INV **Inverter control bit.** If an external clock is used as the timer input clock and $INV = 1$, the external clock is inverted as it goes into the counter. If the output of the pulse generator (TSTAT) is routed to TCLK and $INV = 1$, the output is inverted before it goes to TCLK. If $INV = 0$, no inversion is performed on the input or output of the timer. The INV bit has no effect, regardless of its value, when TCLK is used in I/O port mode.

TSTAT **Timer status bit.** This bit tracks the output of the timer and sets a CPU interrupt on a transition from 0 to 1. A write has no effect.

13.3.2 Timer Period Register

The timer period register is located at 100028h for timer 0 and at 100038h for timer 1.

The 32-bit timer period register contains the number of timer input clock cycles to count. This number controls the frequency of the timer output signal.

The frequency of timer signaling is determined by the frequency of the timer input clock and the period register. The following equations are valid with either an internal or an external timer clock:

$$f(\text{pulse mode}) = f(\text{timer clock}) \div \text{period register}$$

$$f(\text{clock mode}) = f(\text{timer clock}) \div (2 \times \text{period register})$$

This register is cleared to 0 at reset.

13.3.3 Timer Counter Register

The timer period register is located at 100024h for timer 0 and at 100034h for timer 1.

The 32-bit timer counter register increments with each cycle of the timer input clock. The timer counter can be incremented on the rising edge (INV = 0) or on the falling edge (INV = 1) of an externally generated timer input clock (CLKSRC = 0). With an internally generated timer input clock (CLKSRC = 1), the timer counter increments on the rising edge only. The timer counter is zeroed whenever its value equals that of the period register.

This register is cleared to 0 at reset.

13.3.4 Boundary Conditions in the Control Registers

Certain boundary conditions, such as a zero in the period register and an overflow of the counter, affect timer operation. These conditions are listed as follows:

- When the period and counter registers are zero, the operation of the timer depends on the C/\overline{P} mode selected. In pulse mode ($C/\overline{P} = 0$), TSTAT is set and remains set. In clock mode ($C/\overline{P} = 1$), the width of a cycle is $2/f(H1)$, and external clocks are ignored.
- When the counter register is not 0 and the period register = 0, the counter will count until it reaches its maximum 32-bit value (0FFFF FFFFh), roll over to 0, and then function as described in the preceding bullet.
- When the counter register is set to a value greater than the value of the period register, the counter reaches its maximum 32-bit value (0FFFF FFFFh), rolls over to 0, and continues.

Note:

Writes from the peripheral bus override register updates from the counter and new status updates to the control register.

13.4 Timer Pulse Generation

The timer pulse generator (see Figure 13–1) can generate several different TSTAT signals. These signals can be inverted (set by the INV bit) into the timer output signal. The two basic pulse generation modes are pulse mode and clock mode, as shown in Figure 13–4. You can select the mode with the C/\bar{P} bit of the timer global control register. In both modes, an internal clock source has a frequency of $f(H1) \div 2$, and an external clock source has a maximum frequency of $f(H1) \div 2.6$. In pulse mode ($C/\bar{P} = 0$), the width of the pulse is $1/f(H1)$. In clock mode ($C/\bar{P} = 1$), the width of the pulse is the period register divided by the frequency of the timer input clock.

Figure 13–4. Timer Pulse Mode and Clock Mode Timing

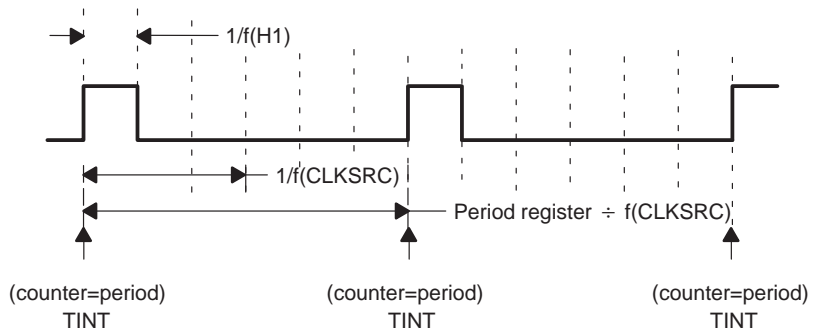

(a) TSTAT and timer output (INV = 0) when $C/\bar{P} = 0$ (pulse mode)

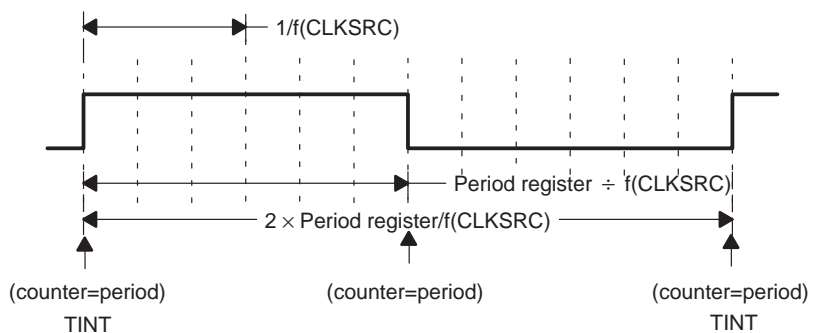

(b) TSTAT and timer output (INV = 0) when $C/\bar{P} = 1$ (clock mode)

Note: TINT is the timer interrupt signal generated whenever TSTAT transitions from 0 to 1.

The rate of the timer output (TSTAT) is determined by the frequency of the timer input clock and the period register. The following equations are valid with either an internal or an external timer clock:

In pulse mode: $f(\text{TSTAT}) = f(\text{timer input clock}) \div \text{period register}$

In clock mode: $f(\text{TSTAT}) = f(\text{timer input clock}) \div (2 \times \text{period register})$

If the period register equals zero, refer to subsection 13.3.2, *Timer Period Register*.

Figure 13–5 provides some examples of TSTAT and timer output (INV = 0) when the period register is set to various values and clock or pulse mode is selected. Timer input clock is generated internally ($f(H1 \div 2)$).

Figure 13–5. Timer Output Generation Examples

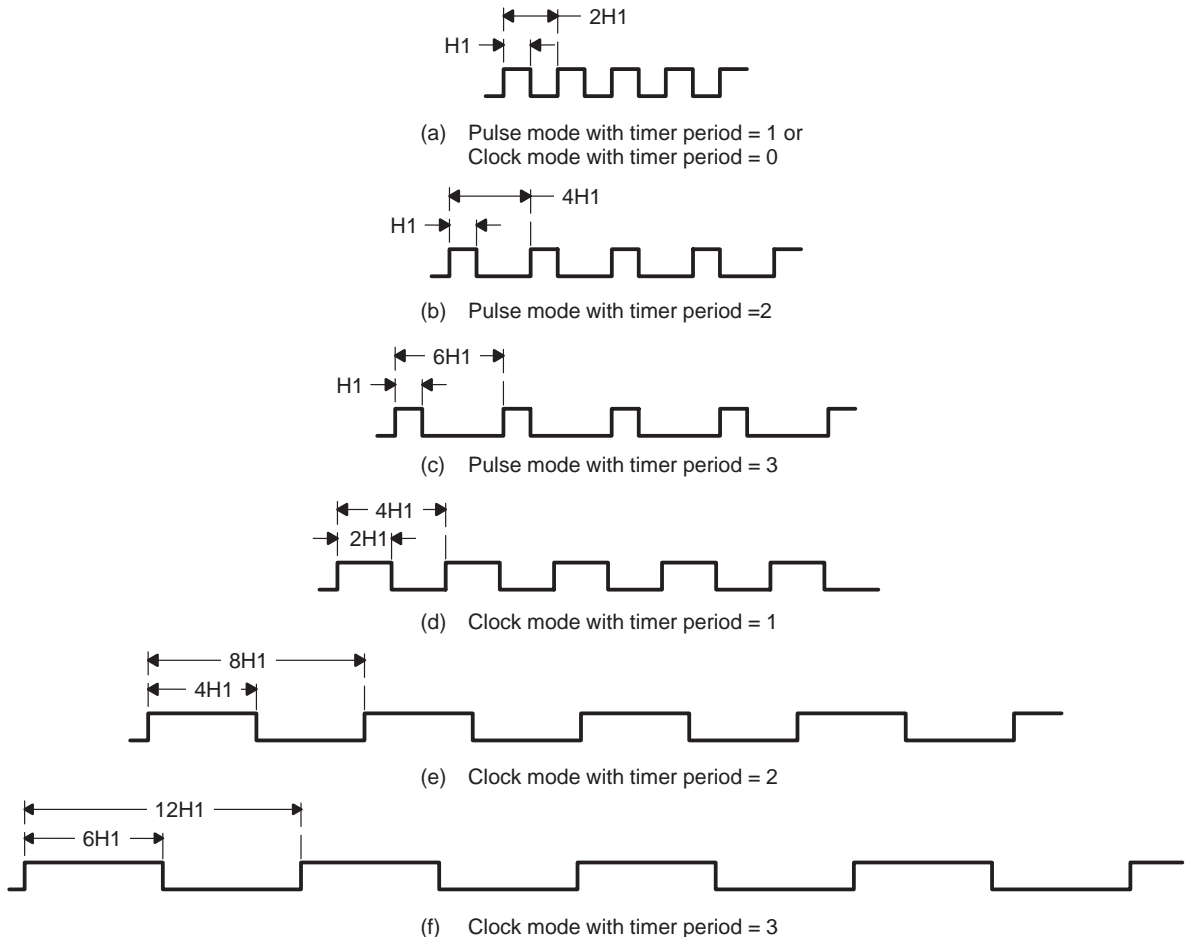

13.5 Timer Interrupts

Each timer can send an interrupt to the CPU when the TSTAT signal transitions from 0 to 1. Timer 0 sends TINT0 and timer 1 sends TINT1.

TINT0. This interrupt uses the interrupt vector at IVTP + 002h. It has a priority level of two, which is second only to NMI and RESET.

TINT1. This interrupt uses the interrupt vector at IVTP + 02Bh. It has the lowest priority level of all interrupts.

13.5.1 Timer Interrupts and Their Vectors

TINT0 corresponds to timer 0. This interrupt uses the interrupt vector at IVTP + 002h. It has a priority level of two, which is second only to NMI and RESET.

TINT1 corresponds to timer 1. This interrupt uses the interrupt vector at IVTP + 02Bh. It has the lowest priority level of all interrupts.

13.5.2 Timer Interrupt Operation

A timer interrupt is generated whenever TSTAT transitions from a zero to a one. The frequency of timer interrupts depends on whether the timer is set up in pulse mode or clock mode.

In pulse mode, the interrupt frequency is:

$$f(\text{interrupt}) = f(\text{input timer clock}) \div \text{period register}$$

In clock mode, the interrupt frequency is:

$$f(\text{interrupt}) = f(\text{input timer clock}) \div (2 \times \text{period register})$$

If the period register equals zero, see subsection 13.3.4, *Boundary Conditions in the Control Registers*, on page 13-8, for more information.

The timer interrupt can be used to interrupt either the CPU or the DMA coprocessor.

The timer interrupt enable bits for the CPU are found in the IIE register. Bit 0 in the IIE corresponds to TINT0, and bit 1 corresponds to TINT1. For more information about the IIE register, see subsection 3.1.9, *CPU Internal Interrupt Enable Register (IIE)*, on page 3-11.

The timer interrupt enable bits for the DMA control register are found in the DIE register. Several bits in this register control how each DMA channel responds

to the timers. For more information about the DIE register, see subsection 13.3.4, *Boundary Conditions in the Control Registers*.

13.5.3 Considerations When Using a Timer Interrupt

The main consideration when using a timer to interrupt the CPU is the priority needed for the operation. If the timer operation has a low priority compared to other devices, then use timer 1, since that timer's interrupt has the lowest priority of all interrupts. If, on the other hand, the timer operation has a high priority compared to other devices, then use timer 0, since that timer's interrupt is second in priority only to an NMI.

13.6 Selecting CLKSRC and FUNC Values

The timer can receive its input and send its output in several different modes, depending on the setting of CLKSRC, FUNC, and \bar{I}/O . The four timer modes of operation are defined by the values of CLKSRC and FUNC in the global control register.

13.6.1 CLKSRC = 1 and FUNC = 0.

If CLKSRC = 1 and FUNC = 0 (see Figure 13–6), the timer input comes from the internal clock. Interrupts can still be generated during the transition of TSTAT from 0 to 1. The internal clock is not affected by the INV bit in the global control register. In this mode, TCLK is connected to the I/O port control and can be used as a general-purpose I/O pin. If $\bar{I}/O = 0$, TCLK is configured as a general-purpose input pin whose state can be read in DATIN. DATOUT has no effect on TCLK or DATIN. If $\bar{I}/O = 1$, TCLK is configured as a general-purpose output pin. DATOUT is placed on TCLK and can be read in DATIN.

Figure 13–6. Timer Configuration With CLKSRC=1 and FUNC=0

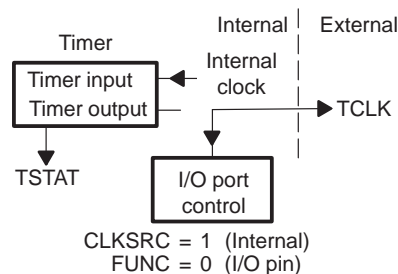

13.6.2 CLKSRC=1 and FUNC=1.

If CLKSRC = 1 and FUNC = 1 (see Figure 13–7), the timer input comes from the internal clock, and the timer output goes to TCLK. You can invert the value on TCLK by setting INV to 1. Also, the value of TCLK can be read in DATIN.

Figure 13–7. Timer Configuration With CLKSRC = 1 and FUNC = 1

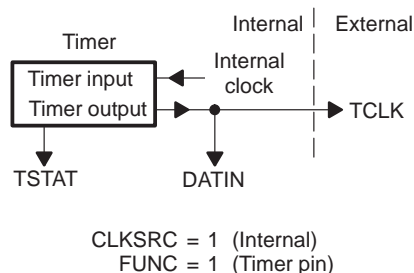

13.6.3 CLKSRC = 0 and FUNC = 0

If CLKSRC = 0 and FUNC = 0 (see Figure 13–8), the timer can still generate interrupt signals and is driven according to the status of the \bar{I}/O bit:

- ❑ If $\bar{I}/O = 0$, the timer input comes from TCLK. You can invert the value read from TCLK by setting INV to 1, and the value of TCLK can be read through DATIN.
- ❑ If $\bar{I}/O = 1$, TCLK is an output pin; both TCLK and the timer are driven by DATOUT. All 0-to-1 transitions of DATOUT increment the counter. INV has no effect on DATOUT. The value of DATOUT can be read through DATIN.

Figure 13–8. Timer Configuration With CLKSRC = 0 and FUNC = 0

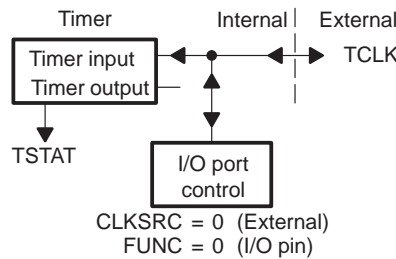

13.6.4 CLKSRC = 0 and FUNC = 1

If CLKSRC = 0 and FUNC = 1 (see Figure 13–9), TCLK drives the timer. If INV = 0, all 0-to-1 transitions of TCLK increment the counter. If INV = 1, all 1-to-0 transitions of TCLK increment the counter. The value of TCLK can be read through DATIN.

Figure 13–9. Timer Configuration With CLKSRC = 0 and FUNC = 1

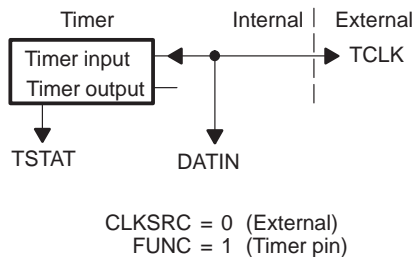

13.7 Using TCLKx as General-Purpose I/O Pins

When $\text{FUNC} = 0$, TCLKx can be used as an I/O pin. Figure 13–10 and Figure 13–11 show how the TCLKx is connected when it is configured as a general-purpose I/O pin. In Figure 13–10, the I/O bit equals 0 and TCLK is configured as an input pin whose value can be read in the DATIN bit. In Figure 13–11, the I/O bit equals 1 and TCLK is configured as an output pin that outputs the value you wrote in the DATOUT bit.

Figure 13–10. TCLK as an Input (I/O = 0)

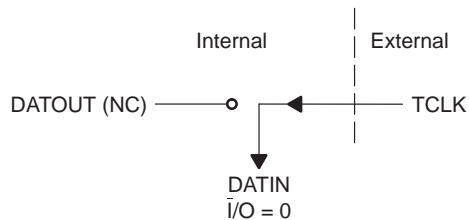
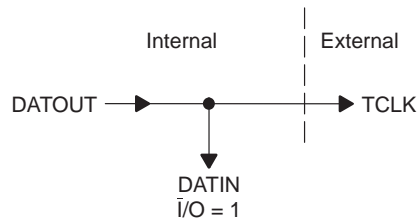

Figure 13–11. TCLK as an Output (I/O = 1)



13.8 Configuring a Timer

Configuring a timer requires three basic steps:

- 1) Halt the timer by clearing to 0 the GO and HLD bits of the timer global-control register. To do this, write a 0 to the timer global-control register. Note that the timers are halted on RESET.
- 2) Configure the timer via the timer global-control register (with GO=HLD=0), the timer counter register, and timer period register, if necessary.
- 3) Start the timer by setting the GO and HLD bits of the timer global-control register to 1.

Example 13–1 shows how to set up the 'C4x timer to generate the maximum frequency clock through the TCLKx pin.

Example 13–1. Maximum Frequency Timer Clock Setup

```
* TITLE MAXIMUM FREQUENCY TIMER CLOCK SETUP
*
* THIS EXAMPLE SHOWS HOW TO SET UP TIMER TO GENERATE MAXIMUM
* FREQUENCY TIMER CLOCK USING INTERNAL CLOCK. WHERE
* "TIMER_REGISTER" SECTION IS LOCATED FROM 100020h.
*
TIM0_CTL_REG .usect "TIMR_REGISTER",4
TIM0_CNT_REG .usect "TIMR_REGISTER",4
TIM0_PRD_REG .usect "TIMR_REGISTER",8
.text
.
.
.
LDI    0,R0
STI    R0,@TIM0_PRD_REG
LDI    3C1H,R0
STI    R0,@TIM0_CTL_REG
.
.
.end
```

Assembly Language Instructions

The 'C4x assembly language instruction set supports numeric-intensive, signal processing, and general-purpose applications. The instructions are organized into these major groups: load-and-store, two- or three-operand arithmetic/logical, parallel, program control, and interlocked operations instructions. The addressing modes used with the instructions are described in Chapter 6.

The 'C4x instruction set can also use one of 20 condition codes with any of the 10 conditional instructions, such as *LDFcond*. This chapter defines the condition codes and flags.

The assembler allows optional syntax forms to simplify the assembly language for special-case instructions. These optional forms are listed and explained.

Each of the individual instructions is described and listed in alphabetical order. An example instruction (on pages 14-23 through 14-25) demonstrates the special format used and explains its content.

This chapter discusses these topics:

Topic	Page
14.1 Instruction Set	14-2
14.2 Condition Codes and Flags	14-12
14.3 Individual Instruction Descriptions	14-16

14.1 Instruction Set

The 'C4x instruction set is exceptionally well-suited to digital signal processing and other numeric-intensive applications. All instructions are a single machine word long, and most instructions take a single cycle to execute. In addition to multiply and accumulate instructions, the 'C4x possesses a full complement of general-purpose instructions.

The instruction set contains 145 instructions organized into the following functional groups:

- Load-and-store
- Two-operand arithmetic/logical
- Three-operand arithmetic/logical
- Program control
- Interlocked operations
- Parallel operations

Each of these groups is discussed in the succeeding subsections.

14.1.1 Load-and-Store Instructions

The 'C4x supports 24 load-and-store instructions (see Table 14–1). These instructions can:

- Load a word from memory into a register
- Store a word from a register into memory
- Manipulate data on the system stack
- Transfer data between primary register and expansion register

Two of these instructions can load data conditionally. This is useful for locating the maximum or minimum value in a data set. See Section 14.2 for detailed information on condition codes.

Table 14–1. Load-and-Store Instructions

Instruction	Description	Instruction	Description
L B b†	Load byte (signed)	LDPK†	Load DP register immediate
LBU b †	Load byte (unsigned)	LHw†	Load half-word signed
LDA†	Load address register	LHUw†	Load half-word unsigned
LDE	Load floating-point exponent	LWL c †	Load word left-shifted
LDEPT	Load integer, expansion-file register to primary register	LWR c †	Load word right-shifted
LDF	Load floating-point value	POP	Pop integer from stack
LDF <i>cond</i>	Load floating-point value conditionally	POPF	Pop floating-point value from stack
LDH I †	Load 16-bit unsigned immediate into 16 MSBs	PUSH	Push integer on stack
LDI	Load integer	PUSHF	Push floating-point value on stack
LDI <i>cond</i>	Load integer conditionally	STF	Store floating-point value
LDM	Load floating-point mantissa	STI	Store integer
LDPE†	Load integer, primary register to expansion file register	STIK†	Store integer immediate

† The 'C4x instruction set is a superset of the 'C3x instruction set. The instructions marked are 'C4x-specific.

14.1.2 Two-Operand Instructions

The 'C4x supports a complete set of 43 two-operand arithmetic and logical instructions. The two operands are the source and destination. The source operand can be a memory word, a register, or a constant. The destination operand is always a register.

These instructions provide integer, floating-point, or logical operations, and multiprecision arithmetic. Table 14–2 lists these instructions.

Table 14–2. Two-Operand Instructions

Instruction	Description	Instruction	Description
ABSF	Absolute value of a floating-point number	MPYF†	Multiply floating-point values
ABSI	Absolute value of an integer	MPYI†	Multiply integers
ADDC†	Add integers with carry	MPYSHI†‡	Multiply signed integer, 32-MSB product
ADDF†	Add floating-point values	MPYUHI†‡	Multiply unsigned integer, 32-MSB product
ADDI†	Add integers	NEGB	Negate integer with borrow
AND†	Bitwise logical-AND	NEGF	Negate floating-point value
ANDN†	Bitwise logical-AND with complement	NEGI	Negate integer
ASH†	Arithmetic shift	NORM	Normalize floating-point value
CMPF†	Compare floating-point values	NOT	Bitwise logical-complement
CMPI†	Compare integers	OR†	Bitwise logical-OR
FIX	Convert floating-point value to integer	RCPF‡	Reciprocal floating point
FLOAT	Convert integer to floating-point value	RND	Round floating-point value
FRIEEE‡	Convert IEEE floating-point format to 2s-complement floating-point format	ROL	Rotate left
LSH†	Logical shift	ROLC	Rotate left through carry
MBc†‡	Merge byte, left shifted	ROR	Rotate right
MHc†‡	Merge half-word, left shifted	RORC	Rotate right through carry

† Two- and three-operand versions

‡ The 'C4x instruction set is a superset of the 'C3x instruction set. The instructions marked are 'C4x-specific.

Table 14–2. Two-Operand Instructions (Continued)

Instruction	Description	Instruction	Description
RSQRF‡	Reciprocal of square root, floating-point	SUBRF	Subtract reverse floating-point value
SUBB†	Subtract integers with borrow	SUBRI	Subtract reverse integer
SUBC	Subtract integers conditionally	TOIEEE‡	Convert 2s complement to IEEE format
SUBF†	Subtract floating-point values	TSTB†	Test bit fields
SUBI†	Subtract integer	XOR†	Bitwise exclusive-OR
SUBRB	Subtract reverse integer with borrow		

† Two- and three-operand versions.

‡ The 'C4x instruction set is a superset of the 'C3x instruction set. The instructions marked are 'C4x-specific.

14.1.3 Three-Operand Instructions

Most instructions contain two or three operands. The 19 three-operand instructions allow the 'C4x to read two operands from memory or the CPU register file in a single cycle and store the results in a register. The following differentiates the two- and three-operand instructions:

- ❑ Two-operand instructions have one source operand (or shift count) and a destination operand.
- ❑ Three-operand instructions may have two source operands (or one source operand and a count operand) and a destination operand. A source operand can be a memory word, a register or a constant. The destination of a three-operand instruction is always a register.

Table 14–3 lists the instructions that have three-operand versions. Note that the 3 in the mnemonic can be omitted from three-operand instructions (see subsection 14.3.2).

Table 14–3. Three-Operand Instructions

Instruction	Description	Instruction	Description
ADDC3	Add with carry	MPYI3	Multiply integers
ADDF3	Add floating-point values	MPYSHI3†	Multiply signed integer, 32-MSB product
ADDI3	Add integers	MPYUHI3†	Multiply unsigned integer, 32-MSB product
AND3	Bitwise logical-AND	OR3	Bitwise logical-OR
ANDN3	Bitwise logical-AND with complement	SUBB3	Subtract integers with borrow
ASH3	Arithmetic shift	SUBF3	Subtract floating-point values
CMPF3	Compare floating-point values	SUBI3	Subtract integers
CMPI3	Compare integers	TSTB3	Test bit fields
LSH3	Logical shift	XOR3	Bitwise exclusive-OR
MPYF3	Multiply floating-point values		

† The 'C4x instruction set is a superset of the 'C3x instruction set. The instructions marked are 'C4x-specific.

14.1.4 Program Control Instructions

The program-control instruction group consists of all of those instructions (24) that affect program flow. The repeat mode allows repetition of a block of code (RPTB and RPTBD) or of a single line of code (RPTS). Both standard and delayed (single-cycle) branching are supported. Several of the program control instructions are capable of conditional operations (see Section 14.2 for detailed information on condition codes). Table 14–4 lists the program control instructions.

Table 14–4. Program Control Instructions

Instruction	Description	Instruction	Description
<i>Bcond</i>	Branch conditionally (standard)	LAJ†	Link and jump
<i>BcondAF</i> †	Branch conditionally delayed and annul if false	LAJ <i>cond</i> †	Link and jump conditional
<i>BcondAT</i> †	Branch conditionally delayed and annul if true	LAT <i>cond</i> †	Link and trap conditional
<i>BcondD</i>	Branch conditionally (delayed)	NOP	No operation
BR‡	Branch unconditionally (standard)	RETI <i>cond</i>	Return from interrupt conditionally
BRD‡	Branch unconditionally (delayed)	RETI- <i>condD</i> †	Return from trap or interrupt, delayed
CALL‡	Call subroutine	RETS <i>cond</i>	Return from subroutine conditionally
CALL <i>cond</i>	Call subroutine conditionally	RPTB‡	Repeat block of instructions
DB <i>cond</i>	Decrement and branch conditionally (standard)	RPTBD	Repeat block, delayed
DB <i>condD</i>	Decrement and branch conditionally (delayed)	RPTS	Repeat single instruction
IACK	Interrupt acknowledge	SWI	Software interrupt
IDLE	Idle until interrupt	TRAP <i>cond</i>	Trap conditionally

† The 'C4x instruction set is a superset of the 'C3x instruction set. The instructions marked are 'C4x-specific.

‡ Operand addressing mode is incompatible with 'C3x.

14.1.5 Interlocked Operations Instructions

The interlocked operations instructions support multiprocessor communication and the use of external signals to allow for powerful synchronization mechanisms. They also guarantee the integrity of the communication and result in a high-speed operation. Refer to Chapter 7 for examples of the use of interlocked instructions.

Table 14–5. Interlocked Operations Instructions

Instruction	Description	Instruction	Description
LDFI	Load floating-point value, interlocked	STFI	Store floating-point value, interlocked
LDII	Load integer, interlocked	STII	Store integer, interlocked
SIGI	Signal, interlocked		

14.1.6 Parallel Operations Instructions

The parallel-operations instructions group makes a high degree of parallelism possible. Some of the 'C4x instructions can occur in pairs that are executed in parallel. These instructions offer the following features:

- Parallel loading of registers
- Parallel store
- Parallel arithmetic operations
- Arithmetic/logical instructions used in parallel with a store instruction.

Each instruction in a pair is entered as a separate source statement. The second instruction in the pair must be preceded by two vertical bars (||). Table 14–6 lists the valid instruction pairs.

Table 14–6. Parallel Instructions

(a) Parallel Arithmetic With Store Instructions

Mnemonic	Description
ABSF STF	Absolute value of a floating-point number and store floating-point value
ABS STI	Absolute value of an integer and store integer
ADDF3 STF	Add floating-point values and store floating-point value
ADDI3 STI	Add integers and store integer
AND3 STI	Bitwise-logical AND and store integer
ASH3 STI	Arithmetic shift and store integer
FIX STI	Convert floating-point to integer and store integer
FLOAT STF	Convert integer to floating-point value and store floating-point value
FRIEEE STF [†]	Convert IEEE floating-point format and store
LDF STF	Load floating-point value and store floating-point value
LDI STI	Load integer and store integer

[†] The 'C4x instruction set is a superset of the 'C3x instruction set. The instructions marked are 'C4x-specific.

Table 14–6. Parallel Instructions (Concluded)*(a) Parallel Arithmetic With Store Instructions (Continued)*

Mnemonic	Description
LSH3 STI	Logical shift and store integer
MPYF3 STF	Multiply floating-point values and store floating-point value
MPYI3 STI	Multiply integer and store integer
NEGF STF	Negate floating-point value and store floating-point value
NEGI STI	Negate integer and store integer
NOT STI	Complement value and store integer
OR3 STI	Bitwise-logical OR value and store integer
STF STF	Store floating-point values
STI STI	Store integers
SUBF3 STF	Subtract floating-point value and store floating-point value
TOIEEE STF [†]	Convert to IEEE format and store
SUBI3 STI	Subtract integer and store integer
XOR3 STI	Bitwise-exclusive OR values and store integer

(b) Parallel Load Instructions

Mnemonic	Description
LDF LDF	Load floating-point
LDI LDI	Load integer

(c) Parallel Multiply and Add/Subtract Instructions

Mnemonic	Description
MPYF3 ADDF3	Multiply and add floating-point
MPYF3 SUBF3	Multiply and subtract floating-point
MPYI3 ADDI3	Multiply and add integer
MPYI3 SUBI3	Multiply and subtract integer

[†] The 'C4x instruction set is a superset of the 'C3x instruction set. The instructions marked are 'C4x-specific.

14.1.7 Illegal Instructions

The 'C4x has no illegal instruction detection mechanism. Fetching an illegal (undefined) code may result in the execution of an undefined operation. If TI TMS320 floating-point software tools are used, no illegal opcodes can be generated. An illegal opcode can only be generated by the misuse of the tools, by an error in the ROM code, or by a defective RAM.

14.2 Condition Codes and Flags

The 'C4x provides 20 condition codes (00000–10100, excluding 01011) that can be used with any of the conditional instructions, such as *RETScond* or *LDFcond*. The conditions include signed and unsigned comparisons, comparisons to zero, and comparisons based on the status of individual condition flags. Note that all conditional instructions can also accept the suffix *U* to indicate unconditional operation.

Seven condition flags provide information about properties of the result of arithmetic and logical instructions. The condition flags are stored in the status register (*ST*); the effect of an instruction on a condition flag depends on the value of the *SET COND* field (bit 15 of the status register). The value of *SET COND* (0 or 1) does not affect the nature of the compare instructions (*CMPF*, *CMPF3*, *CMPI*, *CMPI3*, *TSTB*, or *TSTB3*).

- If *SET COND* = 0, the *ST* condition flags are set if the operation's target is any extended-precision register (*R0–R11*).
- If *SET COND* = 1, the *ST* condition flags are **also** set if the operation's target is *any* register in the primary register file *except* the status register.

The condition flags can be modified by most instructions when either of the preceding conditions is established and either of the following two cases occurs:

- A result is generated when the specified operation is performed to infinite precision. This is appropriate for compare-and-test instructions that do not store results in a register. It is also appropriate for arithmetic instructions that produce underflow or overflow.
- The output is written to the destination register as shown in Table 14–7. This is appropriate for other instructions that modify the condition flags.

Table 14–7. Output Value Formats

Type of Operation	Output Format
Floating-point	8-bit exponent, 1 sign bit, 31-bit fraction
Integer	32-bit integer
Logical	32-bit unsigned integer

Figure 14–1 shows the condition flags in the low-order bits of the status register. Following the figure is a list of status register condition flags and descriptions on how the flags are set by most instructions. For specific details of the effect of a particular instruction on the condition flags, see the description of that instruction in subsection 14.3.3.

Figure 14–1. Status Register

31	30	29	28	27	26	25	24	23	22	21	20	19	18	17	16
xx	xx	xx	xx	xx	xx	xx	xx	xx	xx	xx	xx	xx	xx	xx	Analysis
R	R	R	R	R	R	R	R	R	R	R	R	R	R	R	R
15	14	13	12	11	10	9	8	7	6	5	4	3	2	1	0
SET COND	PGIE	GIE	CC	CE	CF	PCF	RM	OVM	LUF	LV	UF	N	Z	V	C
R/W	R/W	R/W	R/W	R/W	R/W	R/W	R/W	R/W	R/W	R/W	R/W	R/W	R/W	R/W	R/W

NOTE: xx = reserved bit.
R = read, W = write.

- LUF Latched Underflow Condition Flag.** LUF is set whenever UF (floating-point underflow flag) is set. LUF can be cleared only by a processor reset or by modifying it in the status register (ST).
- LV Latched Overflow Condition Flag.** LV is set whenever V (overflow condition flag) is set. Otherwise, it is unchanged. LV can be cleared only by a processor reset or by modifying it in the status register (ST).
- UF Floating-Point Underflow Condition Flag.** A floating-point underflow occurs whenever the exponent of the result is less than or equal to -128 . If a floating-point underflow occurs, UF is set, and the output value is set to 0. UF is cleared if a floating-point underflow does not occur.
- N Negative Condition Flag.** Logical operations assign N (the state of the MSB of the output value). For integer and floating-point operations, N is set if the result is negative, and cleared otherwise. Zero is positive.
- Z Zero Condition Flag.** For logical, integer, and floating-point operations, Z is set if the output is 0, and cleared otherwise.
- V Overflow Condition Flag.** For integer operations, V is set if the result does not fit into the format specified for the destination (i.e., $-2^{32} \leq \text{result} \leq 2^{32} - 1$). Otherwise, V is cleared. For floating-point operations, V is set if the exponent of the result is greater than 127; otherwise, V is cleared. Logical operations always clear V.

C Carry Flag. When an integer addition is performed, C is set if a carry occurs out of the bit corresponding to the MSB of the output. When an integer subtraction is performed, C is set if a borrow occurs into the bit corresponding to the MSB of the output. Otherwise, for integer operations, C is cleared. The carry flag is unaffected by floating-point and logical operations. For shift instructions, this flag is set to the final value shifted out; for a zero shift count, this is set to zero.

Table 14–8 lists the condition mnemonic, code, description, and flag for each of the 19 condition codes.

Table 14–8. Condition Codes and Flags

(a) Unconditional Compares

Condition	Code	Description	Flag†
U	00000	Unconditional	Don't care

(b) Unsigned Compares

Condition	Code	Description	Flag†
LO	00001	Lower than	C
LS	00010	Lower than or same as	C OR Z
HI	00011	Higher than	~C AND ~Z
HS	00100	Higher than or same as	~C
EQ	00101	Equal to	Z
NE	00110	Not Equal to	~Z

(c) Signed Compares

Condition	Code	Description	Flag†
LT	00111	Less than	N
LE	01000	Less than or equal to	N OR Z
GT	01001	Greater than	~N AND ~Z
GE	01010	Greater than or equal to	~N
EQ	00101	Equal to	Z
NE	00110	Not equal to	~Z

(d) Compare to Zero

Condition	Code	Description	Flag†
Z	00101	Zero	Z
NZ	00110	Not zero	~Z
P	01001	Positive	~N AND ~Z
N	00111	Negative	N
NN	01010	Nonnegative	~N

† The ~ means logical complement (“not true” condition).

(e) Compare to Condition Flags

Condition	Code	Description	Flag[†]
NN	01010	Nonnegative	~N
N	00111	Negative	N
NZ	00110	Nonzero	~Z
Z	00101	Zero	Z
NV	01100	No overflow	~V
V	01101	Overflow	V
NUF	01110	No underflow	~UF
UF	01111	Underflow	UF
NC	00100	No carry	~C
C	00001	Carry	C
NLV	10000	No latched overflow	~LV
LV	10001	Latched overflow	LV
NLUF	10010	No latched floating-point underflow	~LUF
LUF	10011	Latched floating-point underflow	LUF
ZUF	10100	Zero or floating-point underflow	Z OR UF

[†] The ~ means logical complement ("not true" condition).

14.3 Individual Instruction Descriptions

This section contains the individual assembly language instructions for the 'C4x. The instructions are listed in alphabetical order. Information for each instruction includes assembler syntax, operation, operands, encoding, description, cycles, status bits, mode bit, and examples.

Definitions of the symbols and abbreviations, as well as optional syntax forms allowed by the assembler, precede the individual instruction description section. Also, an example instruction shows the special format used and explains its content.

You can find a functional grouping of the instructions, as well as a complete instruction set summary in Section 14.1. See Chapter 7, *Addressing and Stack Management*, for information on memory addressing.

14.3.1 Symbols and Abbreviations

Table 14–9 lists the symbols and abbreviations used in the individual instruction descriptions.

Table 14–9. Instruction Symbols

Symbol	Meaning
src	Source operand
src1	Source operand 1
src2	Source operand 2
src3	Source operand 3
src4	Source operand 4
dst	Destination operand
dst1	Destination operand 1
dst2	Destination operand 2
disp	Displacement
cond	Condition
count	Shift count
G	General addressing modes
T	Three-operand addressing modes
P	Parallel addressing modes
B	Conditional-branch addressing modes
ARn	Auxiliary register n
IRn	Index register n
Rn	Extended-precision register address n
RC	Repeat count register
RE	Repeat end address register
RS	Repeat start address register
ST	Status register
C	Carry bit of status register
GIE	Global interrupt enable bit of status register
N	Trap vector
PC	Program counter
RM	Repeat mode flag
SP	System stack pointer
x	Absolute value of x
x → y	Assign the value of x to destination y
x(<i>man</i>)	Mantissa field (sign + fraction) of x
x(<i>exp</i>)	Exponent field of x
op1 op2	Operation 1 performed in parallel with operation 2
x AND y	Bitwise-logical AND of x and y
x OR y	Bitwise-logical OR of x and y
x XOR y	Bitwise-logical XOR of x and y
~x	Bitwise-logical complement of x
x << y	Shift x to the left y bits
x >> y	Shift x to the right y bits
*++SP	Increment SP and use incremented SP as address
*SP--	Use SP as address and decrement SP

14.3.2 Optional Assembler Syntaxes

The assembler allows a relaxed syntax form for some instructions. These optional forms simplify the assembly language so that special-case syntax can be ignored. The following is a list of these optional syntax forms.

- ❑ The destination register can be omitted on unary arithmetic and logical operations when the same register is used as a source. For example,

`ABSI R0,R0` *can be written as* `ABSI R0`

Instructions affected: ABSI, ABSF, FIX, FLOAT, NEGB, NEGF, NEGI, NORM, NOT, RND.

- ❑ All three-operand instructions can be written without the 3. For example,

`ADDI3 R0,R1,R2` *can be written as* `ADDI R0,R1,R2`

Instructions affected: ADDC3, ADDF3, ADDI3, AND3, ANDN3, ASH3, LSH3, MPYF3, MPYI3, OR3, SUBB3, SUBF3, SUBI3, XOR3, MPYSHI3, MPYUHI3.

This also applies to all the pertinent parallel instructions.

- ❑ All three-operand comparison instructions can be written without the 3. For example,

`CMPI3 R0,*AR0` *can be written as* `CMPI R0,*AR0`

Instructions affected: CMPI3, CMPF3, TSTB3.

- ❑ Indirect operands with an explicit 0 displacement are allowed. In three-operand or parallel instructions, operands with 0 displacement are automatically converted to no-displacement mode. For example:

`LDI *+AR0(0),R1` *is legal*

Also

`ADDI3 *+AR0(0),R1,R2` *is equivalent to* `ADDI3 *AR0,R1,R2`

- ❑ Indirect operands can be written with no displacement; in which case, a displacement of 1 is assumed. For example,

`LDI *AR0++(1),R0` *can be written as* `LDI *AR0++,R0`

- ❑ All conditional instructions accept the suffix U to indicate unconditional operation. Also, the U can be omitted from unconditional short branch instructions. For example:

`BU label` *can be written as* `B label`

- ❑ Labels can be written with or without a trailing colon. For example:

`label0: NOP`

`label1 NOP`

`label2: (label assembles to next source line)`

- ❑ Empty expressions are not allowed for the displacement in indirect mode:

`LDI *+AR0(),R0` *is not legal*

- ❑ Immediate-mode destination operands of BR and CALL can be written with an *at* (@) sign :

`BR label` *can be written as* `BR @label`

- ❑ The LDP pseudo-op can be used to load a register (DP by default) with the 16 MSBs of a relocatable address as follows:

`LDP addr,REG` *or* `LDP @addr,REG` *or* `LDP addr`

The *at* (@) sign is optional.

LDP generates an LDIU instruction. An immediate operand with a special relocation type is used.

- ❑ Parallel instructions can be written in either order. For example:

`ADDI`
`|| STI`

can be written as

`STI`
`|| ADDI`

- ❑ The parallel bars indicating part two of a parallel instruction can be written anywhere on the line from column 0 to the mnemonic. For example:

`ADDI`
`|| STI`

can be written as

`ADDI`
`|| STI`

- ❑ If the second operand of a parallel instruction is the same as the third (destination register) operand, the third operand can be omitted. This allows the writing of three-operand parallel instructions that look like normal two-operand instructions. For example,

`ADDI *AR0,R2,R2`
`|| MPYI *AR1,R0,R0`

can be written as

`ADDI *AR0,R2`
`|| MPYI *AR1,R0`

Instructions affected (applies to all parallel instructions that have a register as the second operand): ADDI, ADDF, AND, MPYI, MPYF, OR, SUBI, SUBF, XOR.

Table 14–10. CPU Register Symbols

Register Symbol	Register Machine Value (hex)	Assigned Function Name	Subsection	Page
R0	00	Extended-precision register 0	3.1.1	3-3
R1	01	Extended-precision register 1	3.1.1	3-3
R2	02	Extended-precision register 2	3.1.1	3-3
R3	03	Extended-precision register 3	3.1.1	3-3
R4	04	Extended-precision register 4	3.1.1	3-3
R5	05	Extended-precision register 5	3.1.1	3-3
R6	06	Extended-precision register 6	3.1.1	3-3
R7	07	Extended-precision register 7	3.1.1	3-3
R8	1C	Extended-precision register 8	3.1.1	3-3
R9	1D	Extended-precision register 9	3.1.1	3-3
R10	1E	Extended-precision register 10	3.1.1	3-3
R11	1F	Extended-precision register 11	3.1.1	3-3
AR0	08	Auxiliary register 0	3.1.2	3-4
AR1	09	Auxiliary register 1	3.1.2	3-4
AR2	0A	Auxiliary register 2	3.1.2	3-4
AR3	0B	Auxiliary register 3	3.1.2	3-4
AR4	0C	Auxiliary register 4	3.1.2	3-4
AR5	0D	Auxiliary register 5	3.1.2	3-4
AR6	0E	Auxiliary register 6	3.1.2	3-4
AR7	0F	Auxiliary register 7	3.1.2	3-4
DP	10	Data-page pointer	3.1.3	3-4
IR0	11	Index register 0	3.1.4	3-4
IR1	12	Index register 1	3.1.4	3-4
BK	13	Block-size register	3.1.5	3-5
SP	14	System stack pointer	3.1.6	3-5

Table 14–10. CPU Register Symbols (Continued)

Register Symbol	Register Machine Value (hex)	Assigned Function Name	Subsection	Page
ST	15	Status register	3.1.7	3-5
DIE	16	DMA coprocessor interrupt enable	3.1.8	3-8
IIE	17	Internal-interrupt enable register	3.1.9	3-11
IIF	18	IIOF pins and interrupt flag register	3.1.10	3-13
RS	19	Repeat start address	3.1.11	3-16
RE	1A	Repeat end address	3.1.11	3-16
RC	1B	Repeat counter	3.1.11	3-16
IVTP	00	Interrupt-vector table pointer	3.2	3-17
TVTP	01	Trap-vector table pointer	3.2	3-17

Syntax**INST** *src*, *dst*

or

INST1 *src2*, *dst1*|| **INST2** *src3*, *dst2*

Each instruction begins with an assembler syntax expression. Labels may be placed either before the command (instruction mnemonic) on the same line or on the preceding line in the first column. The optional comment field that concludes the syntax is not included in the syntax expression. A space is required between fields (label, command, operand, and comment fields).

The syntax examples illustrate the common one-line syntax and the two-line syntax used in parallel addressing. Note that the two vertical bars || that indicate a parallel addressing pair can be placed anywhere before the mnemonic on the second line. The first instruction in the pair can have a label, but the second instruction cannot have a label.

Operands*src* general-addressing modes (G):*dst* register (R0 – R11)

The operands segment lists the types of operands that the instruction uses.

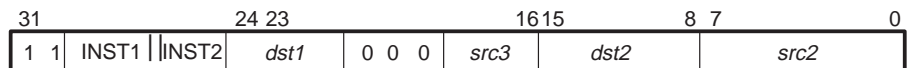
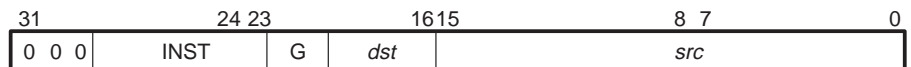
Opcode

Encoding examples are shown for general addressing and parallel addressing. The instruction pair for the parallel addressing example consists of INST1 and INST2. Note that two separate opcodes are listed in this case; each instruction is 32-bits in length in the 'C4x.

Word Fields

G	<i>src</i> addressing modes
00	register (R0 – R11)
01	direct
10	indirect
11	immediate

The word fields segment describes the addressing mode that corresponds to each value of a word field in the opcode. The word field listed in the table corresponds to the field listed under operands.

Operation

|*src*| → *dst*

or

|*src2*| → *dst1*

|| *src3* → *dst2*

The instruction operation sequence describes the processing that takes place when the instruction is executed. For parallel instructions, the operation sequence is performed in parallel. Conditional effects of status register specified modes are listed for conditional instructions such as *Bcond*.

dst register (any register in CPU primary-register file)

or

src2 indirect (disp = 0, 1, IR0, IR1)

dst1 register (R0–R7)

src3 register (R0–R7)

dst2 indirect (disp = 0, 1, IR0, IR1)

Operands are defined according to the addressing mode and/or the type of addressing used. Note that indirect addressing uses displacements and the index registers. See Chapter 6, *Addressing*, for detailed information on addressing.

Description

Instruction execution and its effect on the rest of the processor or memory contents are described in this segment. Any constraints on the operands imposed by the processor or the assembler are discussed. The description parallels and supplements the information given by the operation block.

Status Bits

- LUF** **Latched Floating-Point Underflow Condition Flag.** 1 if a floating-point underflow occurs, unchanged otherwise.
- LV** **Latched Overflow Condition Flag.** 1 if an integer or floating-point overflow occurs, unchanged otherwise.
- UF** **Floating-Point Underflow Condition Flag.** 1 if a floating-point underflow occurs, 0 otherwise.
- N** **Negative Condition Flag.** 1 if a negative result is generated, 0 otherwise. In some instructions, this flag is the MSB of the output.
- Z** **Zero Condition Flag.** 1 if a zero result is generated, 0 otherwise. For logical and shift instructions, 1 if a zero output is generated, 0 otherwise.

- V Overflow Condition Flag.** 1 if an integer or floating-point overflow occurs, 0 otherwise.
- C Carry Flag.** 1 if a carry or borrow occurs, 0 otherwise. For shift instructions, this flag is set to the value of the last bit shifted out; 0 for a shift count of 0.

The seven condition flags are stored in the status register (ST). They provide information about the properties of the result or output of arithmetic or logical operations.

Mode Bit **OVM Overflow Mode Flag.** In general, integer operations are affected by the OVM bit value.

Cycles 1
 The digit specifies the number of cycles required to execute the instruction.

Example

INST @98AEh, R5

Before Instruction		After Instruction	
DP	80h	DP	80h
R5	07 6690 0000h	R5	00 6690 0000h
	2.30562500e + 02		1.80126593e + 00
Memory at 0080 98AEh	5CDFh	Memory at 80 98AEh	5CDFh
	1.00001107e + 00		1.00001107e + 00
LUF	0	LUF	0
LV	0	LV	0
UF	0	UF	0
N	0	N	0
Z	0	Z	0
V	0	V	0
C	0	C	0

The sample code presented in the above format shows the effect of the code on system pointers (e.g., DP or SP), registers (e.g., R1 or R5), memory at specific locations, and the seven status bits. The values given for the registers include the leading zeros to show the exponent in floating-point operations. Decimal conversions are provided for all register and memory locations. The seven status bits are listed in the order in which they appear in the assembler and simulator (see Section 14.2, *Condition Codes and Flags*, and Table 14–8 on page 14-14 for further information on these seven status bits).

Syntax **ABSF** *src2, dst1*
 || **STF** *src3, dst2*

Operands *src2*: indirect (disp = 0, 1, IR0, IR1)
 dst1: register (R0 – R7)
 src3: register (R0 – R7)
 dst2: indirect (disp = 0, 1, IR0, IR1)

Opcode

31	29	24	23	16	15	8	7	0
1	1	0	0	1	0	0	0	0
<i>dst1</i>				<i>src3</i>		<i>dst2</i>		<i>src2</i>

Word Fields None.

Operation |*src2*| → *dst1*
 || *src3* → *dst2*

Description A floating-point absolute value and a floating-point store are performed in parallel. All registers are read at the beginning and loaded at the end of the execute cycle. This means that if one of the parallel operations (STF) reads from a register and the operation being performed in parallel (ABSF) writes to the same register, then STF accepts as input the contents of the register before it is modified by the ABSF.

If *src2* and *dst2* point to the same location, *src2* is read before the write to *dst2*. If *src3* and *dst1* point to the same register, *src3* is read before the write to *dst1*.

An overflow occurs if *src* (man) = 8000 0000h and *src* (exp) = 7Fh. The result is *dst* (man) = 7FFF FFFFh and *dst* (exp) = 7Fh.

Status Bits **LUF** Unaffected
LV 1 if a floating-point overflow occurs, unchanged otherwise
UF 0
N 0
Z 1 if a zero result is generated, 0 otherwise
V 1 if a floating-point overflow occurs, 0 otherwise
C Unaffected

Mode Bit **OVM** operation is not affected by OVM bit value.

Cycles 1

Example

```

|| ABSF  *++AR3(IR1) ,R4
   STF  R4 ,*-AR7(1)

```

Before Instruction		After Instruction			
AR3	80 9800h	AR3	80 98AFh		
IR1	0AFh	IR1	0AFh		
R4	733C0 0000h	1.79750e + 02	R4	574C0 0000h	6.118750e + 01
AR7	80 98C5h	AR7	80 98C5h		
Data at 80 98AFh	58B 4000h	-6.118750e + 01	Data at 80 98AFh	58B 4000h	-6.118750e + 01
Data at 80 98C4h	0h		Data at 80 98C4h	733 C000h	1.79750e + 02
LUF	0	LUF	0		
LV	0	LV	0		
UF	0	UF	0		
N	0	N	0		
Z	0	Z	0		
V	0	V	0		
C	0	C	0		

Example 1

ABSI R0, R0
or ABSI R0

Before Instruction		After Instruction	
R0	0FFFF FFCBh	R0	035h
	-53		53

Example 2

ABSI *AR1, R3

Before Instruction		After Instruction	
AR1	20h	AR1	20h
R3	0h	R3	35h
Data at 20h	0FFFF FFCBh	Data at 20h	0FFFF FFCBh
	-53		-53

Syntax **ABSI** *src2, dst1*
 || **STI** *src3, dst2*

Operands *src2*: indirect (disp = 0, 1, IR0, IR1)
 dst1: register (R0 – R7)
 src3: register (R0 – R7)
 dst2: indirect (disp = 0, 1, IR0, IR1)

Opcode

31	24 23	16 15	8 7	0
1 1	0 0 1 0 1	<i>dst1</i>	0 0 0	<i>src3</i>
			<i>dst2</i>	<i>src2</i>

Word Fields None

Operation |*src2*| → *dst1*
 || *src3* → *dst2*

Description An integer absolute value and an integer store are performed in parallel. All registers are read at the beginning and loaded at the end of the execute cycle. This means that if one of the parallel operations (STI) reads from a register and the operation being performed in parallel (ABSI) writes to the same register, then STI accepts as input the contents of the register before it is modified by the ABSI.

If *src2* and *dst2* point to the same location, *src2* is read before the write to *dst2*.

An overflow occurs if *src* = 8000 0000h. If ST(OVM) = 1, the result is *dst* = 7FFF FFFFh. If ST(OVM) = 0, the result is *dst* = 8000 0000h.

Status Bits **LUF** Unaffected
LV 1 if an integer overflow occurs, unchanged otherwise
UF 0
N 0
Z 1 if a zero result is generated, 0 otherwise
V 1 if an integer overflow occurs, 0 otherwise
C Unaffected

Mode Bit **OVM** operation is affected by OVM bit value.

Cycles 1

Example

```

    ABSI *-AR5(1),R5
|| STI R1,*AR2--(IR1)

```

Before Instruction		After Instruction	
AR5	80 99E2h	AR5	80 99E2h
R5	0h	R5	35h
R1	42h	R1	42h
AR2	80 98FFh	AR2	80 98F0h
IR1	0Fh	IR1	0Fh
Data at 80 99E1h	0FFFF FFCBh	Data at 80 99E1h	0FFFF FFCBh
	-53		-53
Data at 80 98FFh	2h	Data at 80 98FFh	42h
	2		66
LUF	0	LUF	0
LV	0	LV	0
UF	0	UF	0
N	0	N	0
Z	0	Z	0
V	0	V	0
C	0	C	0

Syntax **ADDC** *src, dst*

Operands *src*: general-addressing modes
dst: register (any register in CPU primary-register file)

Opcode

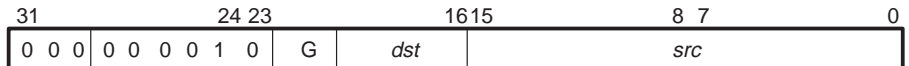

Word Fields

G	<i>src</i> addressing modes
00	register (any register in CPU primary-register file)
01	direct
10	indirect
11	immediate

Operation $dst + src + C \rightarrow dst$

Description The sum of the *dst* and *src* operands and the C (carry) flag is loaded into the *dst* register. The *dst* and *src* operands are assumed to be signed integers.

Status Bits If ST (SET COND) = 0 and the destination register is R0 – R11, the condition flags are modified. If ST (SET COND) = 1, they are modified for all destination registers.

LUF Unaffected
LV 1 if an integer overflow occurs, unchanged otherwise
UF 0
N 1 if a negative result is generated, 0 otherwise
Z 1 if a zero result is generated, 0 otherwise
V 1 if an integer overflow occurs, 0 otherwise
C 1 if a carry occurs, 0 otherwise

Mode Bit **OVM** operation is affected by OVM bit value.

Cycles 1

Example

ADDC R1, R5

Before Instruction			After Instruction		
R1	<input type="text" value="00FFFF 5C25h"/>	-41 947	R1	<input type="text" value="00FFFF 5C25h"/>	-41 947
R5	<input type="text" value="00FFFF 019Eh"/>	-65 122	R5	<input type="text" value="00FFFE 5DC4h"/>	-107 068
LUF	<input type="text" value="0"/>		LUF	<input type="text" value="0"/>	
LV	<input type="text" value="0"/>		LV	<input type="text" value="0"/>	
UF	<input type="text" value="0"/>		UF	<input type="text" value="0"/>	
N	<input type="text" value="0"/>		N	<input type="text" value="0"/>	
Z	<input type="text" value="0"/>		Z	<input type="text" value="0"/>	
V	<input type="text" value="0"/>		V	<input type="text" value="0"/>	
C	<input type="text" value="0"/>		C	<input type="text" value="0"/>	

Description	The sum of the <i>src1</i> and <i>src2</i> operands and value of the C (carry) flag is loaded into the <i>dst</i> register. The <i>src1</i> , <i>src2</i> , and <i>dst</i> operands are assumed to be signed integers.
Status Bits	If ST (SET COND) = 0, the condition flags are modified if the destination register is R0 – R11. If ST (SET COND) = 1, they are modified for all destination registers. LUF Unaffected LV 1 if an integer overflow occurs, unchanged otherwise U 0 N 1 if a negative result is generated, 0 otherwise Z 1 if a zero result is generated, 0 otherwise V 1 if an integer overflow occurs, 0 otherwise C 1 if a carry occurs, 0 otherwise
Mode Bit	OV operation is affected by OVM bit value.
Cycles	1
Example	None

Example

ADDF *AR4++(IR1),R5

Before Instruction		After Instruction			
AR4	80 9800h	AR4	80 992Bhh		
IR1	12Bh	IR1	12Bh		
R5	057980 0000h	6.23750e + 01	R5	09052C 0000h	5.3268750e + 02
Data at 80 9800h	86B 2800h	4.7031250e + 02	Data at 80 9800h	86B 2800h	4.7031250e + 02
LUF	0	LUF	0		
LV	0	LV	0		
UF	0	UF	0		
N	0	N	0		
Z	0	Z	0		
V	0	V	0		
C	0	C	0		

Syntax **ADDF3** *src2, src1, dst*

Operands *src1, src2*: type 1 or type 2 three-operand addressing modes
dst: register mode (R0 – R11)

Opcode

Type 1

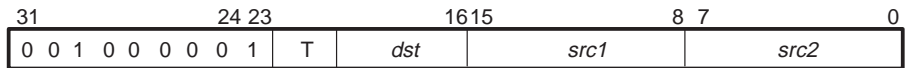

Type 2

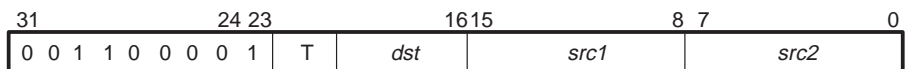

Word Fields

Type 1

T	<i>src1</i> addressing modes	<i>src2</i> addressing modes
00	register mode (R0 – R11)	register mode (R0 – R11)
01	indirect mode (disp = 0, 1, IR0, IR1)	register mode (R0 – R11)
10	register mode (R0 – R11)	indirect mode (disp = 0, 1, IR0, IR1)
11	indirect mode (disp = 0, 1, IR0, IR1)	indirect mode (disp = 0, 1, IR0, IR1)

Type 2

T	<i>src1</i> addressing modes	<i>src2</i> addressing modes
01	register mode (any CPU register)	indirect mode <i>*+ARn</i> (5-bit unsigned displacement)
11	indirect mode <i>*+ARn1</i> (5-bit unsigned displacement)	indirect mode <i>*+ARn2</i> (5-bit unsigned displacement)

Operation

src1 + src2 → *dst*

Description The sum of the *src1* and *src2* operands is loaded into the *dst* register. The *src1*, *src2*, and *dst* operands are assumed to be floating-point numbers.

Status Bits

- LUF** 1 if a floating-point underflow occurs, unchanged otherwise
- LV** 1 if a floating-point overflow occurs, unchanged otherwise
- UF** 1 if a floating-point underflow occurs, 0 otherwise
- N** 1 if a negative result is generated, 0 otherwise
- Z** 1 if a zero result is generated, 0 otherwise
- V** 1 if an floating-point overflow occurs, 0 otherwise
- C** Unaffected

Mode Bit **OVM** operation is not affected by OVM bit value.

Cycles 1

Example `ADDF3 *+AR1(2), *+AR1(8), R4`

Before Instruction		After Instruction	
AR1	2FF820h	AR1	2FF820h
R4	0h	R4	070DB2 0000h 1.41695313e + 02
Data at 22F F822h	700 F000h 1.28940e + 02	Data at 22F F828h	34C 2000h 1.27590e + 01
LUF	0	LUF	0
LV	0	LV	0
UF	0	UF	0
N	0	N	0
Z	0	Z	0
V	0	V	0
C	0	C	0

Syntax **ADDF3** *src2, src1, dst1*
 || **STF** *src3, dst2*

Operands *src1*: register (R0 – R7)
 src2: indirect (disp = 0, 1, IR0, IR1)
 dst1: register (R0 – R7)
 src3: register (R0 – R7)
 dst2: indirect (disp = 0, 1, IR0, IR1)

Opcode

31	24 23	16 15	8 7	0
1 1	0 0 1 1 0	<i>dst1</i>	<i>src1</i>	<i>dst2</i> <i>src2</i>

Word Fields None

Operation *src1 + src2* → *dst1*
 || *src3* → *dst2*

Description A floating-point addition and a floating-point store are performed in parallel. All registers are read at the beginning and loaded at the end of the execute cycle. This means that if one of the parallel operations (STF) reads from a register and the operation being performed in parallel (ADDF3) writes to the same register, then STF accepts as input the contents of the register before it is modified by the ADDF3.

If *src2* and *dst2* point to the same location, *src2* is read before the write to *dst2*.

Status Bits **LUF** 1 if a floating-point underflow occurs, unchanged otherwise
LV 1 if a floating-point overflow occurs, unchanged otherwise
UF 1 if a floating-point underflow occurs, 0 otherwise
N 1 if a negative result is generated, 0 otherwise
Z 1 if a zero result is generated, 0 otherwise
V 1 if an floating-point overflow occurs, 0 otherwise
C Unaffected

Mode Bit **OVM** operation is not affected by OVM bit value.**Cycles** 1

Example

```

ADDF3  *+AR3 ( IR1 ) , R2 , R5
||  STF  R4 , *AR2
    
```

Before Instruction		After Instruction	
AR3	<input type="text" value="80 9800h"/>	AR3	<input type="text" value="80 9800h"/>
IR1	<input type="text" value="0A5h"/>	IR1	<input type="text" value="0A5h"/>
R2	<input type="text" value="070C80 0000h"/> 1.4050e + 02	R2	<input type="text" value="070C80 0000h"/> 1.4050e + 02
R5	<input type="text" value="0h"/>	R5	<input type="text" value="082020 0000h"/> 3.20250e + 02
R4	<input type="text" value="057B40 0000h"/> 6.281250e + 01	R4	<input type="text" value="057B40 0000h"/> 6.281250e + 01
AR2	<input type="text" value="80 98F3h"/>	AR2	<input type="text" value="80 98F3h"/>
Data at 80 98A5h	<input type="text" value="733 C000h"/> 1.79750e + 02	Data at 80 98A5h	<input type="text" value="733 C000h"/> 1.79750e + 02
Data at 80 98F3h	<input type="text" value="0h"/>	Data at 80 98F3h	<input type="text" value="57B 4000h"/> 6.28125e + 01
LUF	<input type="text" value="0"/>	LUF	<input type="text" value="0"/>
LV	<input type="text" value="0"/>	LV	<input type="text" value="0"/>
UF	<input type="text" value="0"/>	UF	<input type="text" value="0"/>
N	<input type="text" value="0"/>	N	<input type="text" value="0"/>
Z	<input type="text" value="0"/>	Z	<input type="text" value="0"/>
V	<input type="text" value="0"/>	V	<input type="text" value="0"/>
C	<input type="text" value="0"/>	C	<input type="text" value="0"/>

Example

ADDI R3, R7

Before Instruction			After Instruction		
R3	0FFFF FFCBh	-53	R3	0FFFF FFCBh	-53
R7	35h	53	R7	0h	
LUF	0		LUF	0	
LV	0		LV	0	
UF	0		UF	0	
N	0		N	0	
Z	0		Z	1	
V	0		V	0	
C	0		C	0	

Syntax **ADDI3** *src2, src1, dst*

Operands *src1, src2*: type 1 or type 2 three-operand addressing modes
dst: register mode (any register in CPU primary-register file)

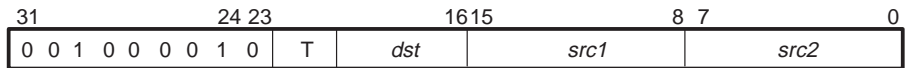
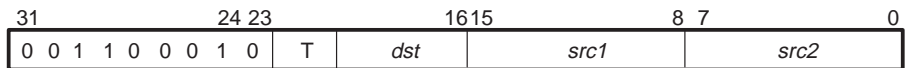
Opcode**Type 1****Type 2****Word Fields****Type 1**

T	<i>src1</i> addressing modes	<i>src2</i> addressing modes
00	register mode (any CPU register)	register mode (any CPU register)
01	indirect mode (disp = 0, 1, IR0, IR1)	register mode (any CPU register)
10	register mode (any CPU register)	indirect mode (disp = 0, 1, IR0, IR1)
11	indirect mode (disp = 0, 1, IR0, IR1)	indirect mode (disp = 0, 1, IR0, IR1)

Type 2

T	<i>src1</i> addressing modes	<i>src2</i> addressing modes
00	register mode (any CPU register)	8-bit signed immediate
01	register mode (any CPU register)	indirect mode $*+ARn$ (5-bit unsigned displacement)
10	indirect mode $*+ARn$ (5-bit unsigned displacement)	8-bit signed immediate
11	indirect mode $*+ARn1$ (5-bit unsigned displacement)	indirect mode $*+ARn2$ (5-bit unsigned displacement)

Operation

$src1 + src2 \rightarrow dst$

Description	The sum of the <i>src1</i> and <i>src2</i> operands is loaded into the <i>dst</i> register. The <i>src1</i> , <i>src2</i> , and <i>dst</i> operands are assumed to be signed integers.
Status Bits	If ST (SET COND) = 0 and the destination register is R0 – R11, the condition flags are modified. If ST (SET COND) = 1, they are modified for all destination registers. LUF Unaffected LV 1 if an integer overflow occurs, unchanged otherwise UF 0 N 1 if a negative result is generated, 0 otherwise Z 1 if a zero result is generated, 0 otherwise V 1 if an integer overflow occurs, 0 otherwise C 1 if a carry occurs, 0 otherwise
Mode Bit	OVM operation is affected by OVM bit value.
Cycles	1
Example	None

Syntax **ADDI3** *src2, src1, dst1*
 || **STI** *src3, dst2*

Operands *src1*: register (R0 – R7)
 src2: indirect (disp = 0, 1, IR0, IR1)
 dst1: register (R0 – R7)
 src3: register (R0 – R7)
 dst2: indirect (disp = 0, 1, IR0, IR1)

Opcode

31	24	23	16	15	8	7	0
1	1	0	0	1	1	1	1
		<i>dst1</i>	<i>src1</i>	<i>src3</i>	<i>dst2</i>		<i>src2</i>

Word Fields None

Operation *src1 + src2* → *dst1*
 || *src3* → *dst2*

Description An integer addition and an integer store are performed in parallel. All registers are read at the beginning and loaded at the end of the execute cycle. This means that if one of the parallel operations (STI) reads from a register and the operation being performed in parallel (ADDI3) writes to the same register, then STI accepts as input the contents of the register before it is modified by the ADDI3.

If *src2* and *dst2* point to the same location, *src2* is read before the write to *dst2*.

Status Bits **LUF** Unaffected
LV 1 if an integer overflow occurs, unchanged otherwise
UF 0
N 1 if a negative result is generated, 0 otherwise
Z 1 if a zero result is generated, 0 otherwise
V 1 if an integer overflow occurs, 0 otherwise
C 1 if a carry occurs, 0 otherwise

Mode Bit **OVM** operation is affected by OVM bit value.

Cycles 1

Example

```

ADDI3  *AR0--(IR0),R5,R0
|| STI  R3,*AR7
    
```

Before Instruction		After Instruction		
AR0	80 992Ch	AR0	80 9920h	
IR0	0Ch	IR0	0Ch	
R5	0DCh	R5	0DCh	220
R0	0h	R0	208h	520
R3	35h	R3	35h	53
AR7	80 983Bh	AR7	80 983Bh	
Data at 80 992Ch	12Ch	Data at 80 992Ch	12Ch	300
Data at 80 983Bh	0h	Data at 80 983Bh	35h	53
LUF	0	LUF	0	
LV	0	LV	0	
UF	0	UF	0	
N	0	N	0	
Z	0	Z	0	
V	0	V	0	
C	0	C	0	

Example

AND R1, R2

	Before Instruction	After Instruction
R1	<input type="text" value="80h"/>	<input type="text" value="80h"/>
R2	<input type="text" value="0AFFh"/>	<input type="text" value="80h"/>
LUF	<input type="text" value="0"/>	<input type="text" value="0"/>
LV	<input type="text" value="0"/>	<input type="text" value="0"/>
UF	<input type="text" value="0"/>	<input type="text" value="0"/>
N	<input type="text" value="0"/>	<input type="text" value="0"/>
Z	<input type="text" value="0"/>	<input type="text" value="0"/>
V	<input type="text" value="0"/>	<input type="text" value="0"/>
C	<input type="text" value="1"/>	<input type="text" value="1"/>

Description The bitwise logical-AND between the *src1* and *src2* operands is loaded into the *dst* register. The *src1*, *src2*, and *dst* operands are assumed to be unsigned integers. The immediate *src2* addressing mode is sign-extended.

Status Bits If ST (SET COND) = 0 and the destination register is R0 – R11, the condition flags are modified. If ST (SET COND) = 1, they are modified for all destination registers.

LUF Unaffected
LV Unaffected
UF 0
N MSB of the output
Z 1 if a zero result is generated, 0 otherwise
V 0
C Unaffected

Mode Bit **OVM** operation is not affected by OVM bit value.

Cycles 1

Example Notice the difference between AND and AND3, in this example:

```
AND3  80h, R0, R0      R0=FFFF FFFFh   R0=FFFF FF80h
AND   80h, R0          R0=FFFF FFFFh   R0=0000 0080h
```

Example

```

    AND3 *+AR1( IR0 ),R4,R7
|| STI R3,*AR2

```

Before Instruction			After Instruction		
AR1	80 99F1h		AR1	80 99F1h	
IR0	8h		IR0	8h	
R4	0A323h		R4	0A323h	
R7	0h		R7	03h	
R3	35h	53	R3	35h	53
AR2	80 983Fh		AR2	80 983Fh	
Data at 80 99F9h	5C53h		Data at 80 99F9h	5C53h	
Data at 80 983Fh	0h		Data at 80 983Fh	35h	53
LUF	0		LUF	0	
LV	0		LV	0	
UF	0		UF	0	
N	0		N	0	
Z	0		Z	0	
V	0		V	0	
C	0		C	0	

Example

ANDN @980Ch, R2

	Before Instruction	After Instruction
DP	<input type="text" value="80h"/>	<input type="text" value="80h"/>
R2	<input type="text" value="0C2Fh"/>	<input type="text" value="042Dh"/>
Data at 80 980Ch	<input type="text" value="0A02h"/>	<input type="text" value="0A02h"/>
LUF	<input type="text" value="0"/>	<input type="text" value="0"/>
LV	<input type="text" value="0"/>	<input type="text" value="0"/>
UF	<input type="text" value="0"/>	<input type="text" value="0"/>
N	<input type="text" value="0"/>	<input type="text" value="0"/>
Z	<input type="text" value="0"/>	<input type="text" value="0"/>
V	<input type="text" value="0"/>	<input type="text" value="0"/>
C	<input type="text" value="0"/>	<input type="text" value="0"/>

Description	The bitwise-logical AND between the <i>src1</i> operand and the bitwise-logical complement (~) of the <i>src2</i> operand is loaded into the <i>dst</i> register. The <i>src1</i> , <i>src2</i> , and <i>dst</i> operands are assumed to be unsigned integers. The immediate <i>src2</i> addressing mode is sign-extended.
Status Bits	LUF Unaffected LV Unaffected UF 0 N MSB of the output Z 1 if a zero result is generated, 0 otherwise V 0 C Unaffected
Mode Bit	OVM operation is not affected by OVM bit value.
Cycles	1
Example	None

Syntax **ASH** *src_count, dst*

Operands *src_count*: general-addressing modes
dst: register (any register in CPU primary-register file)

Opcode

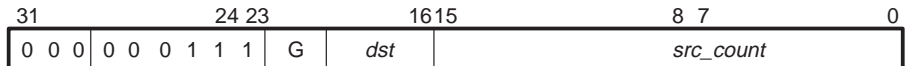

Word Fields

G	<i>src</i> addressing modes
00	register (any register in CPU primary-register file)
01	direct
10	indirect
11	immediate

Operation $count = 7$ LSBs of *src_count*
 If ($count \geq 0$):
 $dst \ll count \rightarrow dst$
 Else:
 $dst \gg |count| \rightarrow dst$

Description The seven least-significant bits of the *src_count* operand constitute the 2s-complement shift *count* of up to 32 bits.

If *count* is greater than 0, the *dst* operand is left-shifted by the value of *count*. Low-order bits shifted in are zero-filled, and high-order bits are shifted out through the C (carry) bit.

Arithmetic left-shift:

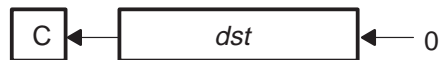

If *count* is less than 0, the *dst* operand is right-shifted by the absolute value of *count*. The high-order bits of the *dst* operand are sign-extended as it is right-shifted. Low-order bits are shifted out through the C (carry) bit.

Arithmetic right-shift:

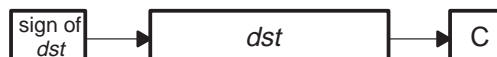

If *count* is 0, no shift is performed, and the C (carry) bit is set to 0. The *src_count* and *dst* operands are assumed to be signed integers.

Status Bits

If ST (SET COND) = 0 and the destination register is R0 – R11, the condition flags are modified. If ST (SET COND) = 1, they are modified for all destination registers.

- LUF** Unaffected
- LV** 1 if an integer overflow occurs, unchanged otherwise
- UF** 0
- N** MSB of the output
- Z** 1 if a zero result is generated, 0 otherwise
- V** 1 if an integer overflow occurs, 0 otherwise
- C** Set to the value of the last bit shifted out. 0 for a shift *count* of 0

Mode Bit

OVM operation is not affected by OVM bit value.

Cycles

1

Example 1

ASH R1, R3

Before Instruction		After Instruction	
R1	10h	16	R1 10h
R3	0A E00h		R3 0E000 0000h
LUF	0		LUF 0
LV	0		LV 1
UF	0		UF 0
N	0		N 1
Z	0		Z 0
V	0		V 1
C	0		C 0

Example 2

ASH @98C3h, R5

Before Instruction		After Instruction	
DP	80h	16	DP 80h
R5	0AEC0 0001h		R5 0FFFF FFAEh
Data at 80 98C3h	OFFE8	-24	Data at 80 98C3h OFFE8 -24
LUF	0		LUF 0
LV	0		LV 0
UF	0		UF 0
N	0		N 1
Z	0		Z 0
V	0		V 0
C	0		C 1

Syntax **ASH3** *src_count, src, dst*

Operands *src, src_count* type 1 or type 2 three-operand addressing modes
dst register mode (any register in CPU primary register file)

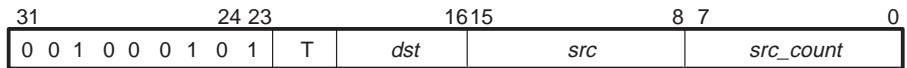
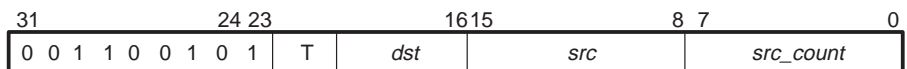
Opcode**Type 1****Type 2****Word Fields****Type 1**

T	<i>src1</i> addressing modes	<i>src2</i> addressing modes
00	register mode (any CPU register)	register mode (any CPU register)
01	indirect mode (disp = 0, 1, IR0, IR1)	register mode (any CPU register)
10	register mode (any CPU register)	indirect mode (disp = 0, 1, IR0, IR1)
11	indirect mode (disp = 0, 1, IR0, IR1)	indirect mode (disp = 0, 1, IR0, IR1)

Type 2

T	<i>src1</i> addressing modes	<i>src2</i> addressing modes
00	register mode (any CPU register)	8-bit signed immediate
01	register mode (any CPU register)	indirect mode $*+ARn$ (5-bit unsigned displacement)
10	indirect mode $*+ARn$ (5-bit unsigned displacement)	8-bit signed immediate
11	indirect mode $*+ARn1$ (5-bit unsigned displacement)	indirect mode $*+ARn2$ (5-bit unsigned displacement)

Operation

count = 7 LSBs of *src_count*
 if (*count* ≥ 0)
 $src \ll count \rightarrow dst$

Else:
 $src \gg |count| \rightarrow dst$

Description

The seven least-significant bits of the *src_count* operand constitute the 2s-complement shift *count*.

If *count* is greater than 0, the *src* operand is left-shifted by the value of *count*. Low-order bits shifted in are zero-filled, and high-order bits are shifted out through the status register's C (carry) bit.

Arithmetic left-shift:

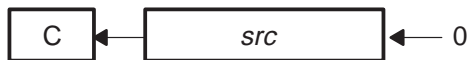

If *count* is less than 0, the *src* operand is right-shifted by the absolute value of *count* (e.g. $-4 = \text{right-shift } 4$). The high-order bits of the *src* operand are sign-extended as they are right-shifted. Low-order bits are shifted out through the C (carry) bit.

Arithmetic right-shift:



If *count* is 0, no shift is performed, and the C (carry) bit is set to 0. The *src_count*, *src*, and *dst* operands are assumed to be signed integers.

Status Bits

- LUF** Unaffected
- LV** 1 if an integer overflow occurs, unchanged otherwise
- UF** 0
- N** MSB of the output
- Z** 1 if a zero result is generated, 0 otherwise
- V** 1 if an integer overflow occurs, 0 otherwise
- C** Set to the value of the last bit shifted out. 0 for a shift *count* of 0

Mode Bit

OVM operation is not affected by OVM bit value.

Cycles

1

Example

None

Syntax **ASH3** *src_count, src2, dst1*
 || **STI** *src3, dst2*

src2 << *count* → *dst1*
 Else:
src2 >> |*count*| → *dst1*
 || *src3* → *dst2*

Operands *src_count* register (R0 – R7)
src2: indirect (disp = 0, 1, IR0, IR1)
dst1: register (R0 – R7)
src3: register (R0 – R7)
dst2: indirect (disp = 0, 1, IR0, IR1)

Opcode

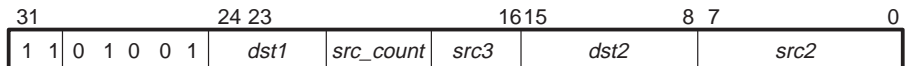

Word Fields None

Operation *count* = 7 LSBs of *src_count*
 If (*count* ≥ 0):

Description The seven least-significant bits of the *src_count* operand register constitute the 2s-complement shift *count* of up to 32 bits.

If *count* is greater than 0, the *dst* operand is left-shifted by the value of *count*. Low-order bits shifted in are zero-filled, and high-order bits are shifted out through the C (carry) bit.

Arithmetic left-shift:

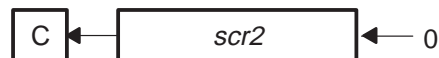

If *count* is less than 0, the *dst* operand is right-shifted by the absolute value of *count*. The high-order bits of the *dst* operand are sign-extended as it is right-shifted. Low-order bits are shifted out through the C (carry) bit.

Arithmetic right-shift:



If *count* is 0, no shift is performed, and the C (carry) bit is set to 0. The *src_count* and *dst* operands are assumed to be signed integers.

All registers are read at the beginning and loaded at the end of the execute cycle. This means that if one of the parallel operations (STI) reads from a register and the operation being performed in parallel (ASH3) writes to the same register, then STI accepts as input the contents of the register before it is modified by the ASH3. If *src2* and *dst2* point to the same location, *src2* is read before the write to *dst2*.

Status Bits

- LUF** Unaffected
- LV** 1 if an integer overflow occurs, unchanged otherwise
- UF** 0
- N** MSB of the output
- Z** 1 if a zero result is generated, 0 otherwise
- V** 1 if an integer overflow occurs, 0 otherwise
- C** Set to the value of the last bit shifted out. 0 for a shift count of 0

Mode Bit

OVM operation is not affected by OVM bit value.

Cycles

1

Example

```
ASH3  R1, *AR6++(IR1), R0
|| STI  R5, *AR2
```

Before Instruction		After Instruction	
AR6	80 9900h	AR6	80 998Ch
IR1	8Ch	IR1	8Ch
R1	OFFE8h	R1	OFFE8h
R0	0h	R0	0FFFF FFAEh
R5	35h	R5	35h
AR2	80 98A2h	AR2	80 98A2h
Data at 80 9900h	0AE00 0000h	Data at 80 9900h	0AE00 0000h
Data at 80 98A2h	0h	Data at 80 98A2h	35h
LUF	0	LUF	0
LV	0	LV	0
UF	0	UF	0
N	0	N	1
Z	0	Z	0
V	0	V	0
C	0	C	0

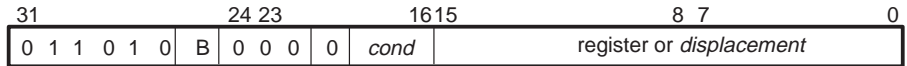
Syntax **Bcond** *src***Operands** *src*: conditional-branch-addressing modes (B)**Opcode****Word Fields**

B	<i>src</i> addressing modes
0	register
1	PC relative

OperationIf *cond* is true:

If *src* is in register-addressing mode (any register in CPU primary-register file),
src → PC.

If *src* is in PC-relative mode (label or address), *displacement* + PC + 1 → PC.
 Else, continue.

Description

Bcond signifies a standard branch that executes in four cycles. A branch is performed if the condition is true (since a pipeline flush also occurs on a true condition; see Section 8.2 on page 8-4). If the *src* operand is expressed in register-addressing mode, the contents of the specified register are loaded into the PC. If the *src* operand is expressed in PC-relative mode, the assembler generates a displacement: *displacement* = label – (PC of branch instruction + 1). This displacement is stored as a 16-bit signed integer in the 16 least-significant bits of the branch instruction word. This displacement is added to the PC of the branch instruction plus 1 to generate the new PC.

The 'C4x provides 20 condition codes that can be used with this instruction (see Section 14.2 for a list of condition mnemonics, encoding, and flags).

Status Bits

LUF Unaffected
LV Unaffected
UF Unaffected
N Unaffected
Z Unaffected
V Unaffected
C Unaffected

Mode Bit**OVM** operation is not affected by OVM bit value.**Cycles**

4 (Regardless of whether or not the branch is taken)

Example

BZ R0

	Before Instruction	After Instruction
PC	<input type="text" value="2B00h"/>	<input type="text" value="3FF00h"/>
R0	<input type="text" value="0003 FF00h"/>	<input type="text" value="0003 FF00h"/>
LUF	<input type="text" value="0"/>	<input type="text" value="0"/>
LV	<input type="text" value="0"/>	<input type="text" value="0"/>
UF	<input type="text" value="0"/>	<input type="text" value="0"/>
N	<input type="text" value="0"/>	<input type="text" value="0"/>
Z	<input type="text" value="1"/>	<input type="text" value="1"/>
V	<input type="text" value="0"/>	<input type="text" value="0"/>
C	<input type="text" value="0"/>	<input type="text" value="0"/>

Note:

If a BZ instruction is executed immediately following a RND instruction with a zero operand, the branch is not performed, because the zero flag is not set. To circumvent this problem, execute a BZUF instead of a BZ instruction.

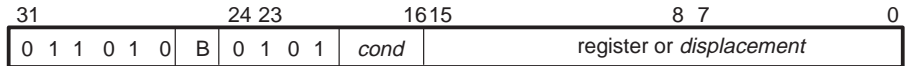
Syntax **BcondAF** *src***Operands** *src*: conditional-branch-addressing modes**Opcode****Word Fields**

B	<i>src</i> addressing modes
0	register
1	PC relative

OperationIf (*cond* is true) If (*src* is a register) *src* → PC If (*src* is in PC-relative mode) *displacement* + PC of branch + 3 → PC

Else:

If (*cond* is false)

annul the effect of the execute phase of the first following instruction and the effect of the read and execute phases of the second and third following instructions and continue.

Description

If the condition is true, a branch and the three instructions following the branch instruction are executed. If the condition is false, no branch is performed, and the effect of the execute phase of the first following instruction and of the read and execute phases of the second and third following instructions is annulled. The three instructions following **BcondAF** do not affect the *cond*. If the *src* operand is in register mode, then the contents of the specified register are loaded into the PC. If the *src* operand is in PC-relative mode, then the sum of the PC of the branch instruction + 3 and the *displacement* is loaded into the PC. In PC-relative mode the *displacement* field is interpreted as a 16-bit signed integer.

None of the three instructions following the **BcondAF** can be an instruction that modifies the program flow. Interrupts are disabled for the duration of the **BcondAF** instruction.

BcondAF especially is useful for controlling the exit at the bottom of a loop. Use caution when using instructions such as **PUSH/POP**, **LDPK**, or **LDA** that can modify registers like AR_n , **SP**, and **DP** in the decode and/or read phase. This also applies when using instructions to perform indirect addressing with AR_n modification.

Status Bits	LUF	Unaffected
	LV	Unaffected
	UF	Unaffected
	N	Unaffected
	Z	Unaffected
	V	Unaffected
	C	Unaffected
Mode Bit	OVM operation is not affected by OVM bit value.	
Cycles	1	
Example	None	

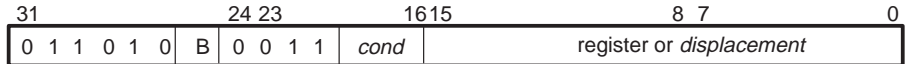
Syntax **BcondAT** *src***Operands** *src* conditional-branch-addressing modes**Opcode****Word Fields**

B	<i>src</i> addressing modes
0	register
1	PC relative

OperationIf (*cond* is true)If (*src* is a register)*src* → PC

annul the effect of the execute phase of the first following instruction and of the read and execute phases of second and third following instructions.

If (*src* is in PC-relative mode)*displacement* + PC of branch + 3 → PC

annul the effect of the execute phase of the first following instruction and of the read and execute phases of second and third following instructions.

Else, continue.

Description

If the condition is true, a branch is performed, and the effect of the execute phase of the first following instruction and of the read and execute phases of second and third following instructions is annulled. The three instructions following **BcondAT** do not affect the *cond*. If the *src* operand is expressed in register mode, then the contents of the specified register are loaded into the PC. If the *src* operand is in PC-relative mode, then the sum of the PC of the branch instruction + 3 and the *displacement* are loaded into the PC. In PC-relative mode, the *displacement* field is interpreted as a 16-bit signed integer.

None of the three instructions following **BcondAT** can be an instruction that modifies the program flow. Interrupts are disabled for the duration of **BcondAT**.

The **BcondAT** instruction does not annul the status signals at the external interfaces. Be especially careful when using instructions such as **PUSH/POP**, **LDPK**, or **LDA** that can modify registers like **AR n** , **SP**, and **DP** in the decode and/or read phase. This also applies when you use instructions to perform indirect addressing with **AR n** modification. **BcondAT** particularly is useful for controlling the entry at the top of the loop.

Status Bits	LUF	Unaffected
	LV	Unaffected
	UF	Unaffected
	N	Unaffected
	Z	Unaffected
	V	Unaffected
	C	Unaffected
Mode Bit	OVM operation is not affected by OVM bit value.	
Cycles	1	
Example	None	

Syntax **BcondD** *src*

Operands *src*: conditional-branch-addressing modes (B)

Opcode

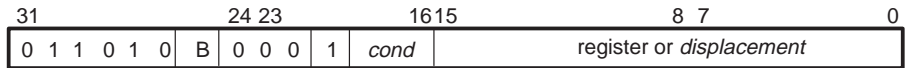
**Word Fields**

B	<i>src</i> addressing modes
0	register
1	PC relative

Operation If *cond* is true:
 If *src* is in register-addressing mode (any register in CPU primary-register file)
src → PC.
 If *src* in PC-relative mode (label or address), *displacement* + PC + 3 → PC.
 Else, continue.

Description *BcondD* signifies a delayed branch, allowing the three instructions after the delayed branch to be performed before the PC is modified. The effect is a single-cycle branch, and the three instructions following *BcondD* do not affect the *cond*.

None of the three instructions following *BcondD* should be an instruction that modifies program flow. Interrupts are disabled for the duration of *BcondD*.

A branch is performed if the condition is true. If the *src* operand is expressed in register-addressing mode, the contents of the specified register are loaded into the PC. If the *src* operand is expressed in PC-relative mode, the assembler generates a displacement: $displacement = src - (PC \text{ of branch instruction} + 3)$. This displacement is stored as a 16-bit signed integer in the 16 least-significant bits of the branch instruction. This displacement is added to the PC of the branch instruction plus 3 to generate the new PC. The 'C4x provides 20 condition codes that can be used with this instruction (see Section 14.2 for a list of condition mnemonics, encoding, and flags).

Status Bits

LUF Unaffected
LV Unaffected
UF Unaffected
N Unaffected
Z Unaffected
V Unaffected
C Unaffected

Mode Bit **OVM** operation is not affected by OVM bit value.

Cycles 1

Example BNZD 36 (36 = 24h)

Before Instruction		After Instruction	
PC	<input type="text" value="50h"/>	PC	<input type="text" value="77h"/>
LUF	<input type="text" value="0"/>	LUF	<input type="text" value="0"/>
LV	<input type="text" value="0"/>	LV	<input type="text" value="0"/>
UF	<input type="text" value="0"/>	UF	<input type="text" value="0"/>
N	<input type="text" value="0"/>	N	<input type="text" value="0"/>
Z	<input type="text" value="1"/>	Z	<input type="text" value="1"/>
V	<input type="text" value="0"/>	V	<input type="text" value="0"/>
C	<input type="text" value="0"/>	C	<input type="text" value="0"/>

Syntax **BR** *src*

Operands *src*: in PC-relative mode

Opcode

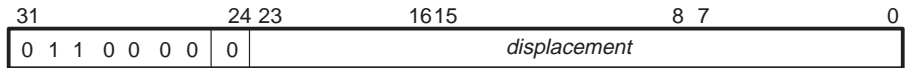

Word Fields None

Operation $PC + 1 + displacement \rightarrow PC$

Description Performs an unconditional branch. The assembler generates a displacement: $displacement = src - (PC \text{ of branch instruction} + 1)$. This displacement is stored as a 24-bit signed integer in the 24 least-significant bits of the branch instruction. This displacement is added to the PC of the branch instruction plus 1 to generate the new PC.

Status Bits

LUF Unaffected

LV Unaffected

UF Unaffected

N Unaffected

Z Unaffected

V Unaffected

C Unaffected

Mode Bit **OVM** operation is not affected by OVM bit value.

Cycles 4

Example None

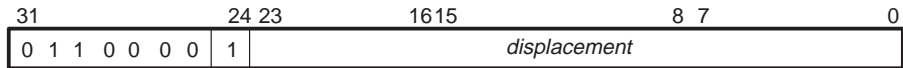
Syntax **BRD** *src***Operands** *src*: in PC-relative mode**Opcode****Word Fields** None**Operation** $PC + 3 + displacement \rightarrow PC$ **Description** Performs an unconditional delayed branch. The assembler generates a displacement: $displacement = src - (PC \text{ of branch instruction} + 3)$. This displacement is stored as a 24-bit signed integer in the 24 least significant bits of the branch instruction. This displacement is added to the PC of the branch instruction plus 3 to generate the new PC. Interrupts are disabled during the BRD instruction.

The three instructions following the BRD instruction are fetched and executed. None of these three instructions should modify the program flow (e.g., affect the PC value).

Status Bits **LUF** Unaffected
LV Unaffected
UF Unaffected
N Unaffected
Z Unaffected
V Unaffected
C Unaffected**Mode Bit** **OVM** operation is not affected by OVM bit value.**Cycles** 1**Example** None

Syntax **CALLcond** *src*

Operands *src*: conditional-branch-addressing modes (B)

Opcod

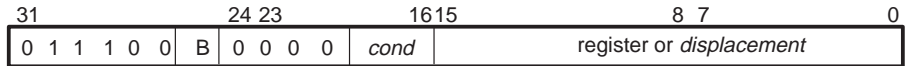

Word Fields

B	<i>src</i> addressing modes
0	register
1	PC relative

Operation If *cond* is true:
 Next PC → *++SP
 If *src* is in register-addressing mode (any register in CPU primary-register file),
 src → PC.
 If *src* in PC-relative mode (label or address), *displacement* + PC + 1 → PC.
 Else, continue.

Description A call is performed if the condition is true. If the condition is true, the next PC value is pushed onto the system stack. If the *src* operand is expressed in register-addressing mode, the contents of the specified register are loaded into the PC. If the *src* operand is expressed in PC-relative mode, the assembler generates a displacement: *displacement* = label – (PC of call instruction + 1). This displacement is stored as a 16-bit signed integer in the 16 least-significant bits of the call instruction word. This displacement is added to the PC of the call instruction plus 1 to generate the new PC.

The 'C4x provides 20 condition codes that can be used with this instruction (see Section 14.2 for a list of condition mnemonics, encoding, and flags).

Status Bits **LUF** Unaffected
 LV Unaffected
 UF Unaffected
 N Unaffected
 Z Unaffected
 V Unaffected
 C Unaffected

Mode Bit **OVM** operation is not affected by OVM bit value.

Cycles 5 (Regardless of whether the condition is true or not)

Example

CALLNZ R5

Before Instruction		After Instruction	
PC	<input type="text" value="123h"/>	PC	<input type="text" value="789h"/>
SP	<input type="text" value="80 9835h"/>	SP	<input type="text" value="80 9836h"/>
R5	<input type="text" value="789h"/>	R5	<input type="text" value="789h"/>
		Data at 9836h	
		<input type="text" value="124h"/>	
LUF	<input type="text" value="0"/>	LUF	<input type="text" value="0"/>
LV	<input type="text" value="0"/>	LV	<input type="text" value="0"/>
UF	<input type="text" value="0"/>	UF	<input type="text" value="0"/>
N	<input type="text" value="0"/>	N	<input type="text" value="0"/>
Z	<input type="text" value="0"/>	Z	<input type="text" value="0"/>
V	<input type="text" value="0"/>	V	<input type="text" value="0"/>
C	<input type="text" value="0"/>	C	<input type="text" value="0"/>

Syntax **CMPF** *src, dst*

Operands *src*: general-addressing modes (G):
dst: register (R0 – R11)

Opcode

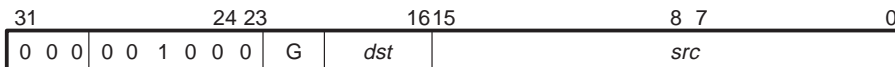

Word Fields

G	<i>src</i> addressing modes
00	register (R0 – R11)
01	direct
10	indirect
11	immediate

Operation *dst – src*

Description The *src* operand is subtracted from the *dst* operand. The result is not loaded into any register; this allows for nondestructive compares. The *dst* and *src* operands are assumed to be floating-point numbers.

Status Bits

LUF 1 if a floating-point underflow occurs, unchanged otherwise
LV 1 if a floating-point overflow occurs, unchanged otherwise
UF 1 if a floating-point underflow occurs, 0 otherwise
N 1 if a negative result is generated, 0 otherwise
Z 1 if a zero result is generated, 0 otherwise
V 1 if a floating-point overflow occurs, 0 otherwise
C Unaffected

Mode Bit **OVM** operation is not affected by OVM bit value.

Cycles 1

Example

CMPF *+AR4, R6

Before Instruction		After Instruction	
AR4	80 98F2h	AR4	80 98F2h
R6	070C80 0000h 1.4050e + 02	R6	070C80 0000h 1.4050e + 02
Data at 80 98F3h	070C 8000h 1.4050e + 02	Data at 80 98F3h	070C 8000h 1.4050e + 02
LUF	0	LUF	0
LV	0	LV	0
UF	0	UF	0
N	1	N	0
Z	0	Z	0
V	0	V	0
C	0	C	0

Syntax **CMPF3** *src2*, *src1*

Operands *src1* – *src2* type 1 or type 2 three-operand addressing modes

Opcode

Type 1

31	24 23	16 15	8 7	0
0 0 1 0 0 0 1 1 0	T	0 0 0 0 0	<i>src1</i>	<i>src2</i>

Type 2

31	24 23	16 15	8 7	0
0 0 1 1 0 0 1 1 0	T	0 0 0 0 0	<i>src1</i>	<i>src2</i>

Word Fields

Type 1

T	<i>src1</i> addressing modes	<i>src2</i> addressing modes
00	register mode (R0 — R11)	register mode (R0 — R11)
01	indirect mode (disp = 0, 1, IR0, IR1)	register mode (R0 — R11)
10	register mode (R0 — R11)	indirect mode (disp = 0, 1, IR0, IR1)
11	indirect mode (disp = 0, 1, IR0, IR1)	indirect mode (disp = 0, 1, IR0, IR1)

Type 2

T	<i>src1</i> addressing modes	<i>src2</i> addressing modes
01	register mode (R11–R0)	indirect mode <i>*+ARn</i> (5-bit unsigned displacement)
11	indirect mode <i>*+ARn1</i> (5-bit unsigned displacement)	indirect mode <i>*+ARn2</i> (5-bit unsigned displacement)

Operation *src1* – *src2*

Description The *src2* operand is subtracted from the *src1* operand. The result is not loaded into any register. This allows for nondestructive compares. The *src1* and *src2* operands are assumed to be floating-point numbers.

Status Bits

LUF 1 if a floating-point underflow occurs, unchanged otherwise

LV 1 if a floating-point overflow occurs, unchanged otherwise

UF 1 if a floating-point underflow occurs, 0 otherwise

N 1 if a negative result is generated, 0 otherwise

Z 1 if a zero result is generated, 0 otherwise

V 1 if a floating-point overflow occurs, 0 otherwise

C Unaffected

Mode Bit **OVM** operation is not affected by OVM bit value.

Cycles

1

Example

CMPF3 *AR2, *AR3-(1)

Before Instruction		After Instruction	
AR2	809831h	AR2	809831h
AR3	809852h	AR3	809851h (decrement)
Data at 809831h	77A7000h	Data at 809831h	77A7000h
	2.5044e + 02		2.5044e + 02
Data at 809852h	57A2000h	Data at 809852h	57A2000h
	6.253125e + 01		6.253125e + 01
LUF	0	LUF	0
LV	0	LV	0
UF	0	UF	0
N	0	N	1
Z	0	Z	0
V	0	V	0
C	0	C	0

Example

CMPI R3,R7

Before Instruction			After Instruction		
R3	<input type="text" value="898h"/>	2200	R3	<input type="text" value="898h"/>	2200
R7	<input type="text" value="3E8h"/>	1000	R7	<input type="text" value="3E8h"/>	1000
LUF	<input type="text" value="0"/>		LUF	<input type="text" value="0"/>	
LV	<input type="text" value="0"/>		LV	<input type="text" value="0"/>	
UF	<input type="text" value="0"/>		UF	<input type="text" value="0"/>	
N	<input type="text" value="0"/>		N	<input type="text" value="1"/>	
Z	<input type="text" value="0"/>		Z	<input type="text" value="0"/>	
V	<input type="text" value="0"/>		V	<input type="text" value="0"/>	
C	<input type="text" value="0"/>		C	<input type="text" value="0"/>	

Syntax **CMPI3** *src2*, *src1*

Operands *src1* – *src2* type 1 or type 2 three-operand addressing modes

Opcode

Type 1

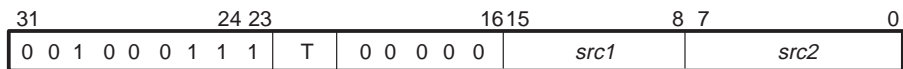

Type 2

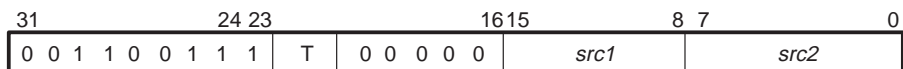

Word Fields

Type1

	T	<i>src1</i> addressing modes	<i>src2</i> addressing modes
	00	register mode (any CPU register)	register mode (any CPU register)
	01	indirect mode (disp = 0, 1, IR0, IR1)	register mode (any CPU register)
	10	register mode (any CPU register)	indirect mode (disp = 0, 1, IR0, IR1)
	11	indirect mode (disp = 0, 1, IR0, IR1)	indirect mode (disp = 0, 1, IR0, IR1)

Type 2

	T	<i>src1</i> addressing modes	<i>src2</i> addressing modes
	00	register mode (any CPU register)	8-bit signed immediate
	01	register mode (any CPU register)	indirect mode *+ARn(5-bit unsigned displacement)
	10	indirect mode *+ARn(5-bit unsigned displacement)	8-bit signed immediate
	11	indirect mode *+ARn1(5-bit unsigned displacement)	indirect mode *+ARn2(5-bit unsigned displacement)

Operation *src1* – *src2*

Description The *src2* operand is subtracted from the *src1* operand. The result is not loaded into any register. This allows for nondestructive compares. The *src1* and *src2* operands are assumed to be signed integers. Although this instruction has only two operands, it is designated as a three-operand instruction because operands are specified in the three-operand format.

Status Bits	LUF	Unaffected
	LV	1 if an integer overflow occurs, unchanged otherwise
	UF	0
	N	1 if a negative result is generated, 0 otherwise
	Z	1 if a zero result is generated, 0 otherwise
	V	1 if an integer overflow occurs, 0 otherwise
	C	1 if a borrow occurs, 0 otherwise
Mode Bit	OVM	operation is not affected by OVM bit value.
Cycles		1
Example		None

Syntax **DBcond** ARn, src

Operands src: conditional-branch-addressing modes (B)
 ARn: auxiliary register

Opcode

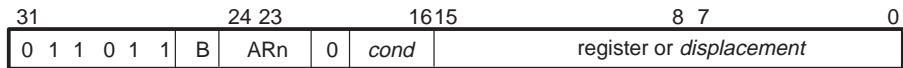

Word Fields

B	src addressing modes
0	register
1	PC relative

Operation ARn – 1 → ARn
 If *cond* is true and ARn ≥ 0 :
 If *src* is in register-addressing mode (any register in CPU primary-register file),
 src → PC.
 If *src* in PC-relative mode (label or address), *displacement* + PC + 1 → PC.
 Else, continue.

Description *DBcond* signifies a standard branch that executes in four cycles because the pipeline must be flushed if *cond* is true. If the condition is true and the specified auxiliary register is greater than or equal to 0, the specified auxiliary register is decremented and a branch is performed.

The auxiliary register is treated as a 32-bit signed integer. Note that the branch condition does not depend on the auxiliary register decrement.

If the *src* operand is expressed in register-addressing mode, the contents of the specified register are loaded into the PC. If the *src* operand is expressed in PC-relative addressing mode, the assembler generates a displacement: *displacement* = label – (PC of branch instruction + 1). This integer is stored as a 16-bit signed integer in the 16 least-significant bits of the branch instruction word. This displacement is added to the PC of the branch instruction plus 1 to generate the new PC.

The 'C4x provides 20 condition codes that can be used with this instruction (see Section 11.2 for a list of condition mnemonics, encoding, and flags).

Status Bits

LUF Unaffected
LV Unaffected
UF Unaffected
N Unaffected
Z Unaffected
V Unaffected
C Unaffected

Mode Bit **OVM** operation is not affected by OVM bit value.

Cycles 4

Example DBLT AR3,R2

Before Instruction		After Instruction	
PC	5Fh	PC	9Fh
AR3	12h	AR3	11h
R2	9Fh	R2	9Fh
LUF	0	LUF	0
LV	0	LV	0
UF	0	UF	0
N	1	N	1
Z	0	Z	0
V	0	V	0
C	0	C	0

Status Bits

LUF Unaffected
LV Unaffected
UF Unaffected
N Unaffected
Z Unaffected
V Unaffected
C Unaffected

Mode Bit **OVM** operation is not affected by OVM bit value.

Cycles 1

Example DBZD AR5, \$+110h

Before Instruction		After Instruction	
PC	0h	PC	110h
AR5	67h	AR5	66h
LUF	0	LUF	0
LV	0	LV	0
UF	0	UF	0
N	0	N	0
Z	1	Z	1
V	0	V	0
C	0	C	0

Syntax **FIX** *src*, *dst*

Operands *src*: general-addressing modes (G)
 dst: register (any register in CPU primary-register file)

Opcode

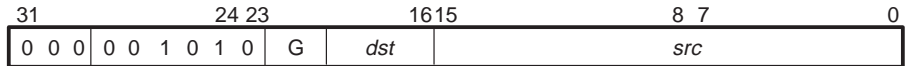

Word Fields

G	<i>src</i> addressing modes
00	register (R0 – R11)
01	direct
10	indirect
11	immediate

Operation $\text{fix}(src) \rightarrow dst$

Description The floating-point operand *src* is converted to the nearest integer less than or equal to it in value, and the result is loaded into the *dst* register. The *src* operand is assumed to be a floating-point number and the *dst* operand is assumed to be a signed integer.

The exponent field of the result register (if it has one) is not modified.

Integer overflow occurs when the floating-point number is too large to be represented as a 32-bit 2s-complement integer. In the case of integer overflow, the result is saturated in the direction of overflow.

Status Bits If ST (SET COND) = 0 and the destination register is R0–R11, the condition flags are modified. If ST (SET COND) = 1, they are modified for all destination registers.

LUF Unaffected
LV 1 if an integer overflow occurs, unchanged otherwise
UF 0
N 1 if a negative result is generated, 0 otherwise
Z 1 if a zero result is generated, 0 otherwise
V 1 if an integer overflow occurs, 0 otherwise
C Unaffected

Mode Bit **OVM** operation is not affected by OVM bit value.

Cycles 1

Example

FIX R1,R2

Before Instruction		After Instruction	
R1	0A2820 0000h	R1	0A2820 0000h
	1.3454e + 3		1.3454e + 3
R2	0h	R2	541h
			1345
LUF	0	LUF	0
LV	0	LV	0
UF	0	UF	0
N	0	N	0
Z	0	Z	0
V	0	V	0
C	0	C	0

Syntax **FIX** *src2, dst1*
 || **STI** *src3, dst2*

Operands *src2*: indirect (disp = 0, 1, IR0, IR1)
 dst1: register (R0 – R7)
 src3: register (R0 – R7)
 dst2: indirect (disp = 0, 1, IR0, IR1)

Opcode

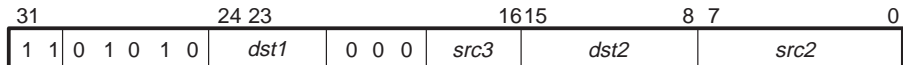

Word Fields None

Operation $\text{fix}(\text{src2}) \rightarrow \text{dst1}$
 || $\text{src3} \rightarrow \text{dst2}$

Description A floating-point-to-integer conversion is performed. All registers are read at the beginning and loaded at the end of the execute cycle. This means that if one of the parallel operations (STI) reads from a register and the operation being performed in parallel (FIX) writes to the same register, then STI accepts as input the contents of the register before it is modified by FIX.

If *src2* and *dst2* point to the same location, *src2* is read before the write to *dst2*.

Integer overflow occurs when the floating-point number is too large to be represented as a 32-bit 2s-complement integer. In the case of integer overflow, the result is saturated in the direction of overflow.

Status Bits **LUF** Unaffected
 LV 1 if an integer overflow occurs, unchanged otherwise
 UF 0
 N 1 if a negative result is generated, 0 otherwise
 Z 1 if a zero result is generated, 0 otherwise
 V 1 if an integer overflow occurs, 0 otherwise
 C Unaffected

Mode Bit **OVM** operation is not affected by OVM bit value.

Cycles 1

Example

```

    FIX    *++AR4(1),R1
|| STI    R0,*AR2

```

Before Instruction		After Instruction	
AR4	80 98A2h	AR4	80 98A3h
R1	0h	R1	0B3h
R0	0DCh	R0	0DCh
AR2	80 983Ch	AR2	80 983Ch
Data at 80 98A3h	733 C000h	Data at 80 98A3h	733 C000h
	1.79750e + 02		1.79750e + 02
Data at 80 983Ch	0h	Data at 80 983Ch	0DCh
	2		220
LUF	0	LUF	0
LV	0	LV	0
UF	0	UF	0
N	0	N	0
Z	0	Z	0
V	0	V	0
C	0	C	0

Syntax **FLOAT** *src, dst*

Operands *src*: general-addressing modes (G)
 dst: register (R0 – R11)

Opcode

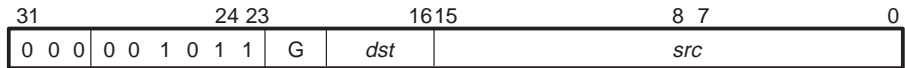

Word Fields

G	<i>src</i> addressing modes
00	register (any register in CPU primary-register file)
01	direct
10	indirect
11	immediate

Operation float (*src*) → *dst*

Description The integer operand *src* is converted to the floating-point value equal to it, and the result loaded into the *dst* register. The *src* operand is assumed to be a signed integer, and the *dst* operand is assumed to be a floating-point number.

Status Bits **LUF** Unaffected
 LV Unaffected
 UF 0
 N 1 if a negative result is generated, 0 otherwise
 Z 1 if a zero result is generated, 0 otherwise
 V 0
 C Unaffected

Mode Bit **OVM** operation is not affected by OVM bit value.

Cycles 1

Example

FLOAT *++AR2(2),R5

Before Instruction		After Instruction	
AR2	80 9800h	AR2	80 9802h
R5	034C 2000h 1.27578125e + 01	R5	072E0 0000h 1.74e + 02
Data at 80 9802h	0AEh 174	Data at 80 9802h	0AEh 174
LUF	0	LUF	0
LV	0	LV	0
UF	0	UF	0
N	0	N	0
Z	0	Z	0
V	0	V	0
C	0	C	0

Syntax **FLOAT** *src2, dst1*
 || **STF** *src3, dst2*

Operands *src2*: indirect (disp = 0, 1, IR0, IR1)
 dst1: register (R0 – R7)
 src3: register (R0 – R7)
 dst2: register (disp = 0, 1, IR0, IR1)

Opcode

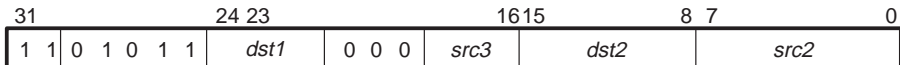

Operation float(*src2*) → *dst1*
 || *src3* → *dst2*

Description An integer-to-floating-point conversion is performed. All registers are read at the beginning and loaded at the end of the execute cycle. This means that if one of the parallel operations (STF) reads from a register and the operation being performed in parallel (FLOAT) writes to the same register, then STF accepts as input the contents of the register before it is modified by FLOAT.

If *src2* and *dst2* point to the same location, *src2* is read before the write to *dst2*.

Status Bits **LUF** Unaffected
 LV Unaffected
 UF 0
 N 1 if a negative result is generated, 0 otherwise
 Z 1 if a zero result is generated, 0 otherwise
 V 0
 C Unaffected

Mode Bit **OVM** operation is affected by OVM bit value.

Cycles 1

Example

```

        FLOAT  *+AR2( IR0 ),R6
||     STF    R7, *AR1

```

Before Instruction		After Instruction	
AR2	<input type="text" value="80 98C5h"/>	AR2	<input type="text" value="80 98C5h"/>
IR0	<input type="text" value="8h"/>	IR0	<input type="text" value="8h"/>
R6	<input type="text" value="0h"/>	R6	<input type="text" value="072E00 0000h"/> 1.740e + 02
R7	<input type="text" value="034C20 0000h"/> 1.27578125e + 01	R7	<input type="text" value="034C20 0000h"/> 1.27578125e + 01
AR1	<input type="text" value="80 9933h"/>	AR1	<input type="text" value="80 9933h"/>
Data at 80 98CDh	<input type="text" value="0AEh"/> 174	Data at 80 98CDh	<input type="text" value="0AEh"/> 174
Data at 80 9933h	<input type="text" value="0h"/>	Data at 80 9933h	<input type="text" value="034C 2000h"/> 1.27578125e + 01
LUF	<input type="text" value="0"/>	LUF	<input type="text" value="0"/>
LV	<input type="text" value="0"/>	LV	<input type="text" value="0"/>
UF	<input type="text" value="0"/>	UF	<input type="text" value="0"/>
N	<input type="text" value="0"/>	N	<input type="text" value="0"/>
Z	<input type="text" value="0"/>	Z	<input type="text" value="0"/>
V	<input type="text" value="0"/>	V	<input type="text" value="0"/>
C	<input type="text" value="0"/>	C	<input type="text" value="0"/>

Syntax **FRIEEE** *src, dst*

Operands *src*: direct- or indirect-addressing modes
dst: extended-precision register (R0 – R11)

Opcode

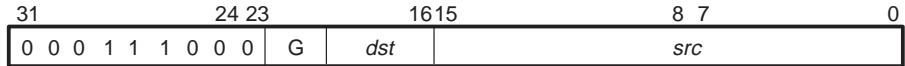

Word Fields

G	src addressing modes
01	direct
10	indirect

Operation convert *src* from IEEE format → *dst*

Description The *src* operand is converted from the IEEE floating-point format to the 2s-complement floating-point format.

The *src* operand comes from memory. The converted result goes into an extended precision register as a single-precision floating-point number.

Status Bits

- LUF** Unaffected
- LV** Set if overflow, otherwise unchanged
- UF** 0
- N** Sign of the result
- Z** 1 if result is 0, 0 otherwise
- V** 1 if overflow, 0 otherwise
- C** Unaffected

Mode Bit **OVM** operation is not affected by OVM bit value.

Cycles 1

Example None

Syntax **FRIEEE** *src2, dst1*
 || **STF** *src3, dst2*

Operands *src2*: indirect mode (disp = 0, 1, IR0, IR1)
 dst1: register mode (R0 – R7)
 src3: register mode (R0 – R7)
 dst2: indirect mode (disp = 0, 1, IR0, IR1)

Opcode

31	24 23	16 15	8 7	0
1 1 1 1 0 0 1	<i>dst1</i>	0 0 0	<i>src3</i>	<i>dst2</i>
				<i>src2</i>

Operation convert *src2* from IEEE format → *dst1*
 in parallel with *src3* → *dst2*

Description The *src2* operand is converted from the IEEE floating-point format to the 2s-complement format. The converted result goes into an extended-precision register *dst1* as a single-precision floating-point number.

A floating-point store is done in parallel.

If *src2* and *dst2* point to the same location, then *src2* is read before the write to *dst2*.

Status Bits **LUF** Unaffected
 LV Set if overflow, otherwise unchanged
 UF 0
 N Sign of the result
 Z 1 if result is 0, 0 otherwise
 V 1 if overflow, 0 otherwise
 C Unaffected

Mode Bit **OVM** operation is not affected by OVM bit value.

Cycles 1

Example None

Syntax **IACK** *src*

Operation *src*: general-addressing modes (G)

Opcode

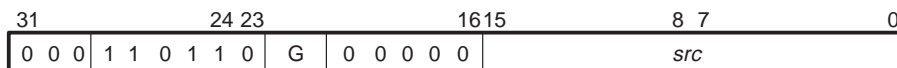

Word Fields

G	<i>src</i> addressing modes
01	direct
10	indirect

Operation Perform a dummy-read operation with $\overline{\text{IACK}} = 0$.
At end of dummy read, set $\overline{\text{IACK}}$ to 1.

Description A dummy-read operation at address pointed by *src* is performed with $\overline{\text{IACK}} = 0$. At the end of the dummy read, $\overline{\text{IACK}}$ is set to 1 **if off-chip memory is specified**. This instruction can be used to generate an external-interrupt acknowledge. The $\overline{\text{IACK}}$ signal and the address can then be used to signal interrupt acknowledge to external devices. The data read by the processor is unused. Note that the $\overline{\text{IACK}}$ signal is extended with multicycle reads.

Status Bits **LUF** Unaffected
LV Unaffected
UF Unaffected
N Unaffected
Z Unaffected
V Unaffected
C Unaffected

Mode Bit **OVM** operation is not affected by OVM bit value.

Cycles 1

Example

IACK *AR5

	Before Instruction	After Instruction
$\overline{\text{IACK}}$	<input type="text" value="1"/>	<input type="text" value="1"/>
PC	<input type="text" value="300h"/>	<input type="text" value="301h"/>
LUF	<input type="text" value="0"/>	<input type="text" value="0"/>
LV	<input type="text" value="0"/>	<input type="text" value="0"/>
UF	<input type="text" value="0"/>	<input type="text" value="0"/>
N	<input type="text" value="0"/>	<input type="text" value="0"/>
Z	<input type="text" value="0"/>	<input type="text" value="0"/>
V	<input type="text" value="0"/>	<input type="text" value="0"/>
C	<input type="text" value="0"/>	<input type="text" value="0"/>

IDLE *Idle Until Interrupt*

Syntax **IDLE**

Operands None

Opcode

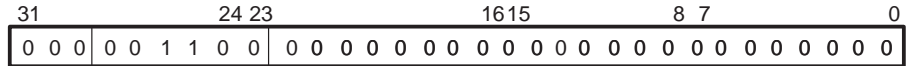

Word Fields None

Operation 1 → ST(GIE)
Next PC → PC
Idle until interrupt

Description The global-interrupt enable bit is set, the next PC value is loaded into the PC, and the CPU idles until an unmasked interrupt is received. When the interrupt is received, the contents of the PC are pushed onto the active system stack, and the processor jumps to execute the interrupt service routine.

Status Bits **LUF** Unaffected
LV Unaffected
UF Unaffected
N Unaffected
Z Unaffected
V Unaffected
C Unaffected

Mode Bit **OVM** operation is not affected by OVM bit value.

Cycles 1

Example None

Syntax **IDLE2** ('C40 revision \geq 5.0 and 'C44 only)

Operands None

Opcode

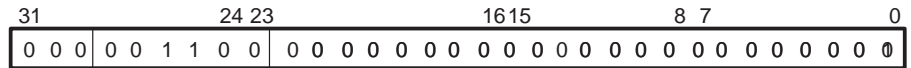

Word Fields None

Operation 1 \rightarrow ST(GIE)
Next PC \rightarrow PC
Idle until interrupt

Description The IDLE2 instruction performs the same function as IDLE, except that it removes the functional clock input from the internal device. This allows for an extremely low-power mode. The PC is incremented once, and the device remains in an idle state until one of the external interrupts ($\overline{\text{NMI}}$ or $\overline{\text{IIOF}}_x$) is asserted.

In IDLE2 mode, the 'C4x behaves as follows:

- The CPU, peripherals, and memory retain their previous states.
- When the device is in the functional (nonemulation) mode, the clocks stop with H1 high and H3 low.
- The 'C4x remains in IDLE2 until one of the external interrupts ($\overline{\text{NMI}}$ or $\overline{\text{IIOF}}_x$) is asserted for at least two H1 clock cycles. Then, the clocks start after a delay of one H1 cycle. The clocks can start up in the phase opposite that in which they were stopped (that is, H1 might start high when H3 was high before stopping, and H3 might start high when H1 was high before stopping). However, the H1 and H3 clocks remain 180° out of phase with each other.
- During IDLE2 operation, for one of the external interrupts to be recognized and serviced by the CPU, it must be asserted for at least two H1 cycles. For the processor to recognize only one interrupt when it restarts operation, the interrupt pin must be configured for edge-triggered mode or asserted for less than three cycles in level-triggered mode.
- When the 'C4x is in the emulation mode, the H1 and H3 clocks continue to run normally, and the CPU operates as if an IDLE instruction had been executed. The clocks continue to run for correct operation of the emulator.
- Any external interrupt pin can wake up the device from IDLE2; but for the CPU to recognize that interrupt, the interrupt must also be enabled. If an interrupt is recognized and executed by the CPU, the instruction following the IDLE2 instruction is not executed until after a return is executed.

Status Bits	LUF	Unaffected
	LV	Unaffected
	UF	Unaffected
	N	Unaffected
	Z	Unaffected
	V	Unaffected
	C	Unaffected
Mode Bit	OVM operation is not affected by OVM bit value.	
Cycles	1	
Example	None	

Syntax **LAJ** *src*

Operands *src*: in PC-relative mode

Opcode

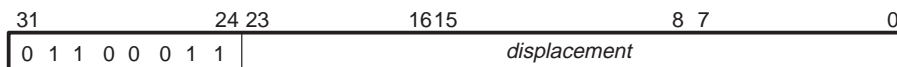

Word Fields None

Operation PC of LAJ + 4 → extended-precision register R11
displacement + 3 + PC of LAJ → PC

Description LAJ performs a single-cycle delayed subroutine call that allows the three instructions following the LAJ instruction to be performed before branching. The return address (address of the LAJ instruction + 4) is placed in extended-precision register R11. The assembler generates a displacement: *displacement* = *src* – (PC of branch instruction + 1). This displacement is stored as a 24-bit signed integer in the 24 least significant bits of the branch instruction. This displacement is added to the PC of the branch instruction plus 1 to generate the new PC. See Section 6.6 on page 6-19 for details.

None of the three instructions following the LAJ instruction should modify R11 or the program flow. Interrupts are disabled for the duration of the LAJ instruction.

Status Bits **LUF** Unaffected
LV Unaffected
UF Unaffected
N Unaffected
Z Unaffected
V Unaffected
C Unaffected

Mode Bit **OVM** operation is not affected by OVM bit value.

Cycles 1

Example None

Syntax LAJcond *src*

Operands *src*: conditional-branch addressing modes

Opcode

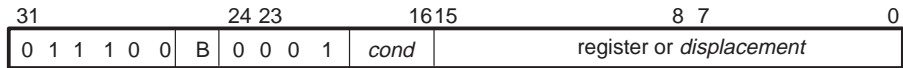

Word Fields

B	<i>src</i> addressing modes
0	register
1	PC relative

Operation

If (*cond* is true)

If (*src* is a register)

PC of LAJcond + 4 → extended-precision register R11

src → PC

If (*src* is in PC-relative mode)

PC of LAJcond + 4 → extended-precision register R11

displacement = *src* − (PC of LAJ + 3)

displacement + PC of the LAJ + 3 → PC

Else, continue.

Description

LAJcond performs a conditional single-cycle delayed subroutine call that allows the three instructions following the LAJcond instruction to be performed before branching, without affecting the *cond*. The return address (address of the LAJ instruction + 4) is placed in extended-precision register R11. The address branched to is formed by either register mode or PC-relative mode.

None of the three instructions following the LAJcond instruction should modify R11 or the program flow. Interrupts are disabled for the duration of the LAJcond instruction.

Status Bits

LUF Unaffected

LV Unaffected

UF Unaffected

N Unaffected

Z Unaffected

V Unaffected

C Unaffected

Mode Bit OVM operation is not affected by OVM bit value.

Cycles 1

Example None

Syntax **LBb** *src, dst*

Operands *src*: register, direct, 16-bit immediate, or indirect-addressing modes
dst: register mode (any register in CPU primary-register file)

Opcode

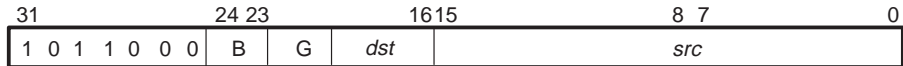

Word Fields

G	<i>src</i> addressing modes	B	<i>src</i> byte
00	register mode	00	byte 0 LS byte
01	direct mode	01	byte 1
10	indirect mode	10	byte 2
11	immediate mode (16 bits)	11	byte 3 MS byte

Operation Sign-extended byte (3, 2, 1, 0) of *src* → *dst*

b = byte to load (3, 2, 1, 0)

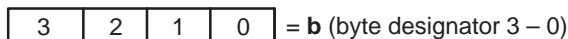

Description The specified byte of the *src* operand is sign-extended and right-shifted into the eight LSBs of the *dst* register. The *src* byte is signed. When immediate mode is specified and byte 2 (B =10) or byte 3 (B =10) is selected, the LBb instruction performs sign extension of the 16-bit value. Consequently, the value of 00h or FFh is stored into the eight LSBs of the *dst* register.

Status Bits If ST (SET COND) = 0 and the destination register is R0 – R11, the condition flags are modified. If ST (SET COND) = 1, they are modified for all destination registers.

- LUF** Unaffected
- LV** Unaffected
- UF** 0
- N** 1 if a negative result is generated, 0 otherwise
- Z** 1 if a zero result is generated, 0 otherwise
- V** 0
- C** Unaffected

Mode Bit **OVM** operation is not affected by OVM bit value.

Cycles 1

Example

LB2 R1, R2 ; sign extended byte 2 of R1 → R2

Before Instruction

R1 00AB 0000h

R2 0000 0000h

After Instruction

R1 00AB 0000h

R2 FFFF FFABh

Syntax **LBUb** *src, dst*

Operands *src*: register, direct, 16-bit immediate, or indirect-addressing modes
dst: register mode (any register in CPU primary-register file)

Opcode

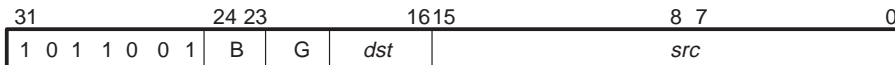

Word Fields

	G <i>src</i> addressing modes		B <i>src</i> byte
00	register mode		00 byte 0 LS byte
01	direct mode		01 byte 1
10	indirect mode		10 byte 2
11	immediate mode (16 bits)		11 byte 3 MS byte

Operation Byte (3, 2, 1, 0) of *src* → *dst*

b = byte to load (3, 2, 1, 0)

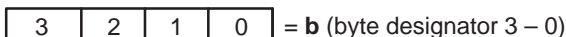

Description

The specified byte of the *src* operand is right-shifted, without sign extension, into the eight LSBs of the *dst* register. The *src* byte is unsigned. When immediate mode is specified and byte 2 (B = 10) or byte 3 (B = 11) is selected, the LBUb instruction performs sign extension of the 16-bit value. Consequently, the value of 00h or FFh is stored into the eight LSBs of the *dst* register.

Status Bits

If ST (SET COND) = 0 and the destination register is R0 – R11, the condition flags are modified. If ST (SET COND) = 1, they are modified for all destination registers.

- LUF** Unaffected
- LV** Unaffected
- UF** 0
- N** 0
- Z** 1 if a zero result is generated, 0 otherwise
- V** 0
- C** Unaffected

Mode Bit

OVM operation is not affected by OVM bit value.

Cycles

1

Example

	Before Instruction	After Instruction
R1	00AB 0000h	00AB 0000h
R2	0000 0000h	0000 00ABh

Syntax **LDA** *src, dst*

Operands *src*: general-addressing modes
 dst: register mode (address registers only)

Opcode

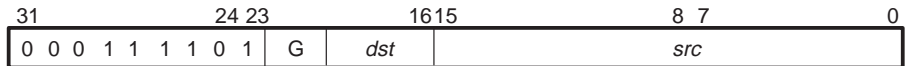

Word Fields

G	<i>src</i> addressing modes
00	register (any register in CPU primary-register file)
01	direct
10	indirect
11	immediate

Operation *src* → *dst*

Description The *src* operand is loaded into the *dst* register. The *dst* register can be any of the address registers: AR0 – AR7, IR0, IR1, DP, BK, or SP. The load is complete by the end of the read phase of the pipeline. As a result, LDA is one cycle faster than LDI for loading these registers. (All operands are treated as signed integers.)

CAUTION
 The *src* and *dst* operands cannot be the same register.

Status Bits **LUF** Unaffected
 LV Unaffected
 UF Unaffected
 N Unaffected
 Z Unaffected
 V Unaffected
 C Unaffected

Mode Bit **OVM** operation is not affected by OVM bit value.

Cycles 1

Example

None

Example

LDE R0, R5

		Before Instruction	After Instruction
R0	<input type="text" value="020005 6F30h"/>	4.00066337e + 00	R0 <input type="text" value="020005 6F30h"/> 4.00066337e + 00
R5	<input type="text" value="0A056F E332h"/>	1.06749648e + 03	R5 <input type="text" value="02056F E332h"/> 4.16990814e + 00
LUF	<input type="text" value="0"/>		LUF <input type="text" value="0"/>
LV	<input type="text" value="0"/>		LV <input type="text" value="0"/>
UF	<input type="text" value="0"/>		UF <input type="text" value="0"/>
N	<input type="text" value="0"/>		N <input type="text" value="0"/>
Z	<input type="text" value="0"/>		Z <input type="text" value="0"/>
V	<input type="text" value="0"/>		V <input type="text" value="0"/>
C	<input type="text" value="0"/>		C <input type="text" value="0"/>

Syntax **LDEP** *src, dst*

Operands *src*: expansion register file register (IVTP or TVTP)
dst: register mode (any register in CPU primary register file)

Opcode

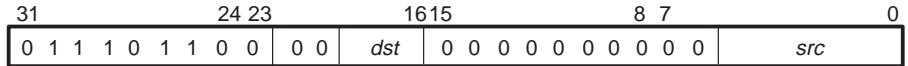

Word Fields None

Operation *src* → *dst*

Description The LDEP instruction loads a CPU register with the contents of the IVTP register (interrupt-trap table pointer) or the TVTP register. These registers are described in Section 3.2.

The *src* operand register from the expansion-register file is loaded into the *dst* register in the primary register file. The *dst* register content is assumed to be an integer.

Status Bits **LUF** Unaffected
LV Unaffected
UF Unaffected
N Unaffected
Z Unaffected
V Unaffected
C Unaffected

Mode Bit **OVM** operation is not affected by OVM bit value.

Cycles 1

Example None

Example

LDF @9800h,R2

Before Instruction		After Instruction	
DP	80h	DP	80h
R2	0h	R2	010C52 A00h 2.19254303e + 00
Data at 80 9800h	10C5 2A00h 2.19254303e + 00	Data at 80 9800h	10C5 2A00h 2.19254303e + 00
LUF	0	LUF	0
LV	0	LV	0
UF	0	UF	0
N	0	N	0
Z	0	Z	0
V	0	V	0
C	0	C	0

Example

LDFZ R3,R5

Before Instruction		After Instruction	
R3	2CFF2C D500h 1.77055560e +13	R3	2CFF2C D500h 1.77055560e +13
R5	5F0000 003Eh 3.96140824e +28	R5	2CFF2C D500h 1.77055560e +13
LUF	0	LUF	0
LV	0	LV	0
UF	0	UF	0
N	0	N	0
Z	1	Z	1
V	0	V	0
C	0	C	0

Syntax **LDFI** *src, dst*

Operands *src*: general-addressing modes (G)
dst: register (R0 – R11)

Opcode

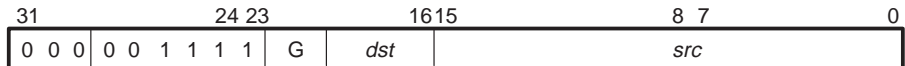

Word Fields

G	<i>src</i> addressing modes
01	direct
10	indirect

Operation Signal interlocked operation.
src → *dst*

Description The *src* operand is loaded into the *dst* register. An interlocked operation is signaled over $\overline{\text{LOCK}}$ or $\overline{\text{LLOCK}}$. The *src* and *dst* operands are assumed to be floating-point numbers. Only direct and indirect modes are allowed. Refer to Section 9.7 (page 9-39) for a detailed description.

Status Bits

- LUF** Unaffected
- LV** Unaffected
- UF** 0
- N** 1 if a negative result is generated, 0 otherwise
- Z** 1 if a zero result is generated, 0 otherwise
- V** 0
- C** Unaffected

Mode Bit **OVM** operation is not affected by OVM bit value.

Cycles 1

Example

LDFI *+AR2,R7

Before Instruction		After Instruction	
AR2	8098F1h	AR2	8098F1h
R7	0h	R7	0584C0 0000h -6.28125e + 01
Data at 80 98F2h	584 C000h -6.28125e + 01	Data at 80 98F2h	584 C000h -6.28125e + 01
LUF	0	LUF	0
LV	0	LV	0
UF	0	UF	0
N	0	N	0
Z	0	Z	0
V	0	V	0
C	0	C	0

Syntax **LDF** *src2*, *dst2*
 || **LDF** *src1*, *dst1*

Operands *src1*: indirect (disp = 0, 1, IR0, IR1)
 dst1: register (R0 — R7)
 src2: indirect (disp = 0, 1, IR0, IR1)
 dst2: register (R0 — R7)

Opcode

31	24	23	16	15	8	7	0
1	1	0	0	0	1	0	0
		<i>dst2</i>	<i>dst1</i>	0	0	0	<i>src1</i>
							<i>src2</i>

Word Fields None

Operation *src2* → *dst2*
 || *src1* → *dst1*

Description Two floating-point loads are performed in parallel. If the LDFs load the same register, the assembler issues a warning. The result is that of LDF *src2*, *dst2*.

Status Bits **LUF** Unaffected
 LV Unaffected
 UF Unaffected
 N Unaffected
 Z Unaffected
 V Unaffected
 C Unaffected

Mode Bit **OVM** operation is not affected by OVM bit value.

Cycles 1

Example

```

LDF *- - AR1 ( IR0 ) , R7
|| LDF *AR7++ ( 1 ) , R3

```

Before Instruction		After Instruction	
AR1	80 985Fh	AR1	80 9857h
IR0	8h	IR0	8h
R7	0h	R7	070C80 0000h 1.4050e + 02
AR7	80 988Ah	AR7	80 988Bh
R3	0h	R3	057B40 0000h 6.281250e + 01
Data at 80 9857h	70C 8000h 1.4050e + 02	Data at 80 9857h	70C 8000h 1.4050e + 02
Data at 80 988Ah	57B 4000h 6.281250e + 01	Data at 80 988Ah	57B 4000h 6.281250e + 01
LUF	0	LUF	0
LV	0	LV	0
UF	0	UF	0
N	0	N	0
Z	0	Z	0
V	0	V	0
C	0	C	0

Example

```

LDF  *AR2--(1),R1
||   STF  R3,*AR4++(IR1)

```

Before Instruction		After Instruction	
AR2	80 98E6h	AR2	80 98E6h
R1	0h	R1	070C80 0000h 1.4050e + 02
R3	057B40 0000h 6.28125e + 01	R3	057B40 0000h 6.28125e + 01
AR4	80 9900h	AR4	80 9910h
IR1	10h	IR1	10h
Data at 80 98E7h	70C 8000h 1.4050e + 02	Data at 80 98E7h	70C 8000h 1.4050e + 02
Data at 80 9900h	0h	Data at 80 9900h	57B 4000h 6.28125e + 01
LUF	0	LUF	0
LV	0	LV	0
UF	0	UF	0
N	0	N	0
Z	0	Z	0
V	0	V	0
C	0	C	0

Syntax **LDHI** *src*, *dst*

Operands *src*: 16-bit unsigned immediate
dst: register mode

Opcode

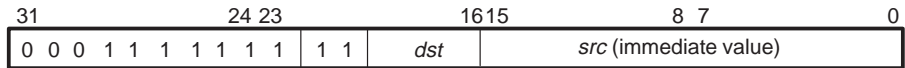

Word Fields None

Operation *src* → 16 MSBs of *dst*

Description The 16-bit unsigned *src* immediate value is loaded into the 16 MSBs of the *dst* register, and 0 is loaded into the 16 LSBs of the *dst* register. The *dst* register is assumed to be an integer.

Status Bits

- LUF** Unaffected
- LV** Unaffected
- UF** Unaffected
- N** Unaffected
- Z** Unaffected
- V** Unaffected
- C** Unaffected

Mode Bit **OVM** operation is not affected by OVM bit value.

Cycles 1

Example LDHI 44h, R2



Syntax **LDI** *src, dst*

Operands *src*: general-addressing modes (G)
dst: register (any register in CPU primary-register file)

Opcode

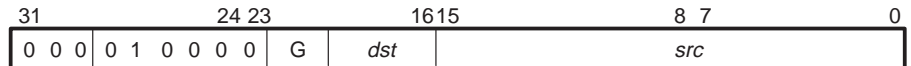

Word Fields None

G	<i>src</i> addressing modes
00	register (any register in CPU primary-register file)
01	direct
10	indirect
11	immediate

Operation *src* → *dst*

Description The *src* operand is loaded into the *dst* register. The *dst* and *src* operands are assumed to be signed integers.

Status Bits

LUF Unaffected
LV Unaffected
UF 0
N 1 if a negative result is generated, 0 otherwise
Z 1 if a zero result is generated, 0 otherwise
V 0
C Unaffected

Mode Bit **OVM** operation is not affected by OVM bit value.

Cycles 1

Example

LDI $*-AR1(IR0), R5$

Before Instruction		After Instruction	
AR1	2Ch	AR1	2Ch
IR0	5h	IR0	5h
R5	3C5h	R5	26h
	965		38
Data at 27h		Data at 27h	
	26h		26h
	38		38
LUF	0	LUF	0
LV	0	LV	0
UF	0	UF	0
N	0	N	0
Z	0	Z	0
V	0	V	0
C	0	C	0

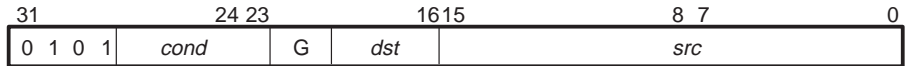
Syntax **LDIcond** *src*, *dst***Operands**
src: general addressing modes (G)
dst: register (any register in CPU primary register file)**Opcode****Word Fields**

G	<i>src</i> addressing modes
00	register (any register in CPU primary register file)
01	direct
10	indirect
11	immediate

Operation
If *cond* is true:
 src → *dst*,
Else: *dst* is unchanged.**Description**
If the condition is true, the *src* operand is loaded into the *dst* register. Otherwise, the *dst* register is unchanged. The *dst* and *src* operands are assumed to be signed integers.

LDP (an alternate form of LDIU) loads the data-page pointer register (DP) or any other register with the 16 MSBs of a relocatable address.

The 'C4x provides 20 condition codes that can be used with this instruction (see Section 14.2 for a list of condition mnemonics, encoding, and flags). Note that a load integer unconditionally (LDIU) instruction is useful for loading a selected CPU register without affecting the condition flags that the LDI instruction affects.

Status Bits
LUF Unaffected
LV Unaffected
UF Unaffected
N Unaffected
Z Unaffected
V Unaffected
C Unaffected**Mode Bit** **OVM** operation is not affected by OVM bit value.**Cycles** 1

Example

LDIZ R4, R6

		Before Instruction		After Instruction	
R4	<input type="text" value="027Ch"/>	636	R4	<input type="text" value="027Ch"/>	636
R6	<input type="text" value="0FE2h"/>	4066	R6	<input type="text" value="0FE2h"/>	4066
LUF	<input type="text" value="0"/>		LUF	<input type="text" value="0"/>	
LV	<input type="text" value="0"/>		LV	<input type="text" value="0"/>	
UF	<input type="text" value="0"/>		UF	<input type="text" value="0"/>	
N	<input type="text" value="0"/>		N	<input type="text" value="0"/>	
Z	<input type="text" value="0"/>		Z	<input type="text" value="0"/>	
V	<input type="text" value="0"/>		V	<input type="text" value="0"/>	
C	<input type="text" value="0"/>		C	<input type="text" value="0"/>	

Syntax **LDII** *src, dst*

Operands *src*: general-addressing modes (G)
dst: register (any register in CPU primary-register file)

Opcode

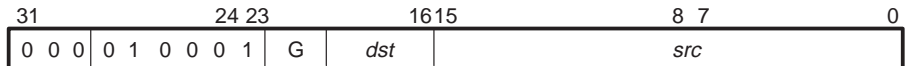

Word Fields

G	<i>src</i> addressing modes
01	direct
10	indirect

Operation Signal interlocked operation.
src → *dst*

Description The *src* operand is loaded into the *dst* register. An interlocked operation is signaled over $\overline{\text{LOCK}}$ or $\overline{\text{LLOCK}}$. The *src* and *dst* operands are assumed to be signed integers. Note that only the direct and indirect modes are allowed. Refer to Section 9.7 on page 9-39 for a detailed description.

Status Bits If ST (SET COND) = 0 and the destination register is R0 – R11, the condition flags are modified. If ST (SET COND) = 1, they are modified for all destination registers.

LUF Unaffected
LV Unaffected
UF 0
N 1 if a negative result is generated, 0 otherwise
Z 1 if a zero result is generated, 0 otherwise
V 0
C Unaffected

Mode Bit **OVM** operation is not affected by OVM bit value.

Cycles 1

Example

LDII @985Fh, R3

	Before Instruction	After Instruction
DP	<input type="text" value="80"/>	<input type="text" value="80"/>
R3	<input type="text" value="0h"/>	<input type="text" value="0DCh"/>
Data at 80 985Fh	<input type="text" value="0DCh"/>	Data at 80 98F5h <input type="text" value="0DCh"/>
LUF	<input type="text" value="0"/>	<input type="text" value="0"/>
LV	<input type="text" value="0"/>	<input type="text" value="0"/>
UF	<input type="text" value="0"/>	<input type="text" value="0"/>
N	<input type="text" value="0"/>	<input type="text" value="0"/>
Z	<input type="text" value="0"/>	<input type="text" value="0"/>
V	<input type="text" value="0"/>	<input type="text" value="0"/>
C	<input type="text" value="0"/>	<input type="text" value="0"/>

Syntax **LDI** *src2*, *dst2*
 || **LDI** *src1*, *dst1*

Operands *src1*: indirect (disp = 0, 1, IR0, IR1)
 dst1: register (R0 – R7)
 src2: indirect (disp = 0, 1, IR0, IR1)
 dst2: register (R0 – R7)

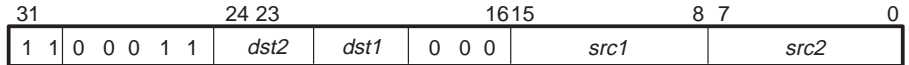
Opcode

Word Fields None

Operation *src2* → *dst2*
 || *src1* → *dst1*

Description Two integer loads are performed in parallel. A warning is issued by the assembler if the LDIs load the same register. The result is that of LDI *src2*, *dst2*.

Status Bits **LUF** Unaffected
 LV Unaffected
 UF Unaffected
 N Unaffected
 Z Unaffected
 V Unaffected
 C Unaffected

Mode Bit **OVM** operation is not affected by OVM bit value.

Cycles 1

Example

```
LDI *-AR1(1),R7
|| LDI *AR7++(IR0),R1
```

Before Instruction		After Instruction	
AR1	80 9826h	AR1	80 9826h
R7	0h	R7	0FAh
AR7	80 98C8h	AR7	80 98D8h
IR0	10h	IR0	10h
R1	0h	R1	02EEh
Data at 80 9825h	0FAh	250	0FAh
Data at 80 98C8h	2EEh	750	2EEh
LUF	0	LUF	0
LV	0	LV	0
UF	0	UF	0
N	0	N	0
Z	0	Z	0
V	0	V	0
C	0	C	0

Example

```
LDI *-AR1(1),R2
|| STI R7,*AR5++(IR0)
```

Before Instruction		After Instruction	
AR1	80 98E7h	AR1	80 98E7h
R2	0h	R2	0DCh
R7	35h	R7	35h
AR5	80 982Ch	AR5	80 9834h
IR0	8h	IR0	8h
Data at 80 98E6h	0DCh	Data at 80 98E6h	0DCh
Data at 80 982Ch	0h	Data at 80 982Ch	35h
LUF	0	LUF	0
LV	0	LV	0
UF	0	UF	0
N	0	N	0
Z	0	Z	0
V	0	V	0
C	0	C	0

53

220

220

53

53

Example

LDM 156.75,R2

(156.75 = 07 1CC0 0000h)

Before Instruction

After Instruction

R2
LUF
LV
UF
N
Z
V
C

R2 1.22460938e + 00
LUF
LV
UF
N
Z
V
C

Syntax `LDP src[,DP]`

Operands *src*: **16 MSBs** of the **absolute 32-bit** source address (*src*).
dst: optional (data-page pointer understood if “,DP” left out of operand)

Opcode

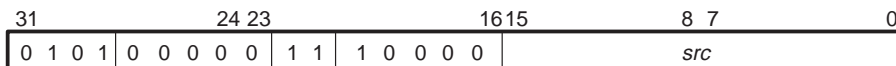

Word Fields None

Operation *src* → Data-page pointer

Description This pseudo-op is an alternate form of the LDIU instruction, except that LDP *is always* in the immediate addressing mode (bits 22 – 21 = 11₂). The 16 MSBs of the *src* absolute 32-bit value (note that an *src* less than 32 bits is zero filled to make the 32 bits) are loaded into the 16 LSBs of the data-page pointer.

The 16 LSBs of the pointer are used in direct addressing as a pointer to the page of data being addressed. There is a total of 64K pages, each page 64K words long. Bits 31 – 16 of the pointer are reserved and should be kept to zero.

Status Bits

- LUF** Unaffected
- LV** Unaffected
- UF** Unaffected
- N** Unaffected
- Z** Unaffected
- V** Unaffected
- C** Unaffected

Mode Bit **OVM** operation is not affected by OVM bit value.

Cycles 1

Example

```
LDP @809900h, DP
or
LDP @809900h
```

	Before Instruction		After Instruction
DP	6465h	DP	0080h
			16MSBs of 32-bit <i>src</i> , zeros extended
LUF	0	LUF	0
LV	0	LV	0
UF	0	UF	0
N	0	N	0
Z	0	Z	0
V	0	V	0
C	0	C	0

Syntax `LDPE src, dst`

Operands
src: register mode (any register in CPU primary-register file)
dst: expansion-register file register (IVTP or TVTP)

Opcode

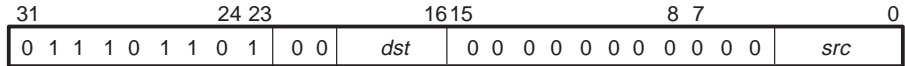

Word Fields None

Operation *src* → *dst*

Description This is a means to load the interrupt vector table pointer (IVTP) register or trap-vector table pointer (TVTP) register. These registers are described in Section 3.2 on page 3-17.

The *src* operand register from the primary-register file is loaded into the *dst* register in the expansion register file. The *dst* operand is assumed to be an integer.

Status Bits

- LUF** Unaffected
- LV** Unaffected
- UF** Unaffected
- N** Unaffected
- Z** Unaffected
- V** Unaffected
- C** Unaffected

Mode Bit **OVM** operation is not affected by OVM bit value.

Cycles 1

Example `LDPE AR0, TVTP ; set trap-vector pointer`

Syntax **LDPK** *src*

Operands *src*: 16-bit unsigned immediate

Opcode

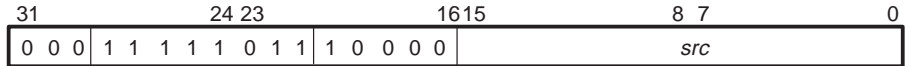

Word Fields None

Operation *src* → DP

Description The 16-bit unsigned immediate value is loaded into the DP register. This operation is completed by the end of the decode phase of the LDPK instruction; thus, the value loaded is ready for the next instruction for immediate addressing. Use caution when using the DP register in the instruction that precedes the LDPK. For example:

```
PUSH DP
LDPK new_value
```

pushes the DP new value into the stack instead of saving the old DP value.

Status Bits

- LUF** Unaffected
- LV** Unaffected
- UF** Unaffected
- N** Unaffected
- Z** Unaffected
- V** Unaffected
- C** Unaffected

Mode Bit **OVM** operation is not affected by OVM bit value.

Cycles 1

Status Bits

If ST (SET COND) = 0 and the destination register is R0–R11, the condition flags are modified. If ST (SET COND) = 1, they are modified for all destination registers.

LUF Unaffected
LV Unaffected
UF 0
N 1 if a negative result is generated, 0 otherwise
Z 1 if a zero result is generated, 0 otherwise
V 0
C Unaffected

Mode Bit

OVM operation is not affected by OVM bit value.

Cycles

1

Example

LH0 R1, R2

	Before Instruction		After Instruction
R1	ABCD EF12h	R1	ABCD EF12h
R2	1234 5678h	R2	FFFF EF12h

Syntax **LHUw** *src*, *dst*

Operands *src*: register, direct, 16-bit immediate-, or indirect- addressing modes
dst: register mode (any register in CPU primary-register file)

Opcode

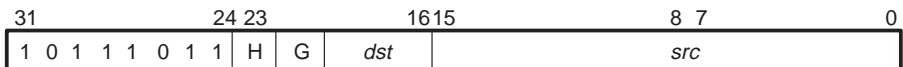

Word Fields

G	<i>src</i> addressing modes
00	register (any register in CPU primary-register file)
01	direct
10	indirect
11	immediate

H	<i>src</i> half-word
0	half-word 0 (LS half-word)
1	half-word 1 (MS half-word)

Operation Unsigned half-word (0, 1) of *src* → *dst*

w = half-word to load (0, 1)

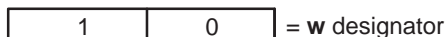

Description The specified half-word of the *src* operand is unsigned and right-shifted into the 16 LSBs of the *dst* register. The *src* half-word is unsigned. When immediate mode is specified and a half-word 1 (H = 1) is selected, the LHw instruction performs sign extension of the 16-bit value into a 32-bit value. Consequently, the corresponding half-word value (0000h or FFFFh) is stored into the 16 LSBs of the *dst* register.

Status Bits

If ST (SET COND) = 0 and the destination register is R0 – R11, the condition flags are modified. If ST (SET COND) = 1, they are modified for all destination registers.

LUF Unaffected
LV Unaffected
UF 0
N 0
Z 1 if a zero result is generated, 0 otherwise
V 0
C Unaffected

Cycles

1

Mode Bit

OVM operation is not affected by OVM bit value.

Example

LHU0 R1, R2

	Before Instruction		After Instruction
R1	ABCD EF12h	R1	ABCD EF12h
R2	1234 5678h	R2	0000 EF12h

Syntax **LSH** *src_count, dst*

Operands *src_count*: general-addressing modes (G)
dst: register (any register in CPU primary-register file)

Opcode

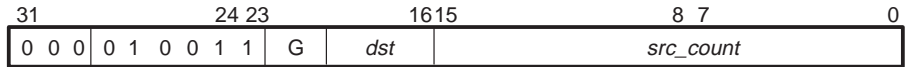

Word Fields

G	<i>src</i> addressing modes
00	register (any register in CPU primary-register file)
01	direct
10	indirect
11	immediate

Operation *count* = 7 LSBs of *src_count*
 If *count* ≥ 0:
 dst << *count* → *dst*
 Else:
 dst >> |*count*| → *dst*

Description The seven LSBs of the *src_count* operand constitute the 2s-complement-shift *count*. If *count* is greater than 0, the *dst* operand is left-shifted by the value of *count*. Low-order bits shifted in are zero-filled, and high-order bits are shifted out through the C (carry) bit.

Logical left-shift:

$$C \leftarrow dst \leftarrow 0$$

If *count* is less than 0, the *dst* is right-shifted by the absolute value of the *count* operand. The high-order bits of the *dst* operand are zero-filled as they are shifted to the right. Low-order bits are shifted out through the C (carry) bit.

Logical right-shift:

$$0 \rightarrow dst \rightarrow C$$

If *count* is 0, no shift is performed, and the C (carry) bit is cleared to 0.

If *count* is greater than 32, the C (carry) bit gets the LSB. If *count* is less than -32, the C bit is cleared to 0.

The *src_count* operand is assumed to be a signed integer, and the *dst* operand is assumed to be an unsigned integer.

Status Bits

If ST (SET COND) = 0 and the destination register is R0–R11, the condition flags are modified. If ST (SET COND) = 1, they are modified for all destination registers.

LUF Unaffected
LV Unaffected
UF 0
N MSB of the output
Z 1 if a zero output is generated, 0 otherwise
V 0
C Set to the value of the last bit shifted out. 0 for a shift *count* of 0

Mode Bit

OVM operation is not affected by OVM bit value.

Cycles

1

Example 1

LSH R4, R7

Before Instruction		After Instruction	
R4	018h	R4	018h
R7	02ACh	R7	0AC00 0000h
LUF	0	LUF	0
LV	0	LV	0
UF	0	UF	0
N	0	N	1
Z	0	Z	0
V	0	V	1
C	0	C	0

Example 2

LSH *-AR5 (IR0), R5

Before Instruction		After Instruction	
AR5	80 9908h	AR5	80 9908h
IR0	4h	IR0	4h
R5	00 12C0 0000h	R5	00 0001 2C00h
Data at 80 9904h	0FFF FFFF4h	Data at 80 9904h	0FFF FFFF4h
LUF	0	LUF	0
LV	0	LV	0
UF	0	UF	0
N	0	N	0
Z	0	Z	0
V	0	V	0
C	0	C	0

Syntax **LSH3** *src_count, src, dst*

Operands *src, src_count*: both type 1 or type 2 three-operand addressing modes
dst: register mode (any register in CPU primary-register file)

Opcode

Type 1

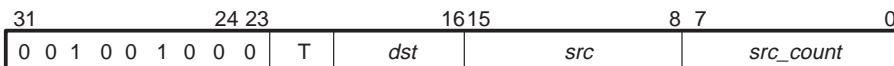

Type 2

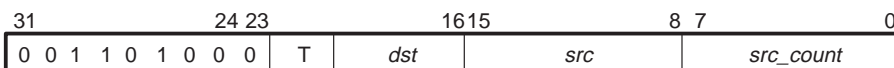

Word Fields

Type 1

	T <i>src</i> addressing modes	<i>src_count</i> addressing modes
00	register mode (any CPU register)	register mode (any CPU register)
01	indirect mode (disp = 0, 1, IR0, IR1)	register mode (any CPU register)
10	register mode (any CPU register)	indirect mode (disp = 0, 1, IR0, IR1)
11	indirect mode (disp = 0, 1, IR0, IR1)	indirect mode (disp = 0, 1, IR0, IR1)

Type 2

	T <i>src</i> addressing modes	<i>src_count</i> addressing modes
00	register mode (any CPU register)	8-bit signed immediate
01	register mode (any CPU register)	indirect mode *+ARn(5-bit unsigned displacement)
10	indirect mode *+ARn(5-bit unsigned displacement)	8-bit signed immediate
11	indirect mode *+ARn1(5-bit unsigned displacement)	indirect mode *+ARn2(5-bit unsigned displacement)

Operation

count = 7 LSBs of *src_count*
 If *count* ≥ 0:
 src << *count* → *dst*
 Else:
 src >> |*count*| → *dst*

Description	<p>The seven LSBs of the <i>src_count</i> operand constitute the 2s-complement shift <i>count</i>.</p> <p>If <i>count</i> is greater than 0, a copy of the <i>src</i> operand is left-shifted by the value of <i>count</i>, and the result is written to the <i>dst</i> (the <i>src</i> is not changed). Low-order bits shifted in are zero-filled, and high-order bits are shifted out through the C (carry) bit.</p> <p>Logical left-shift:</p> $C \leftarrow src \leftarrow 0$ <p>If <i>count</i> is less than 0, the <i>src</i> operand is right-shifted by the absolute value of <i>count</i>. The high-order bits of the <i>dst</i> operand are zero-filled as shifted to the right. Low-order bits are shifted out through the C (carry) bit.</p> <p>Logical right-shift:</p> $0 \rightarrow src \rightarrow C$ <p>If <i>count</i> is 0, no shift is performed and the C (carry) bit is set to 0.</p> <p>If <i>count</i> is greater than 32, the carry (C) bit is set to the LSB. If <i>count</i> is less than 32, the carry bit is cleared to 0. This also applies to LSH.</p> <p>The <i>src_count</i> operand is assumed to be a signed integer. The <i>src</i> and <i>dst</i> operands are assumed to be unsigned integers.</p>
Status Bits	<p>If ST (SET COND) = 0 and the destination register is R0 – R11, the condition flags are modified. If ST (SET COND) = 1, they are modified for all destination registers.</p> <p>LUF Unaffected LV Unaffected UF 0 N MSB of the output Z 1 if a zero output is generated, 0 otherwise V 0 C Set to the value of the last bit shifted out. 0 for a shift <i>count</i> of 0</p>
Mode Bit	OVM operation is not affected by OVM bit value.
Cycles	1
Example	None

Syntax **LSH3** *src_count, src2, dst1*
 || **STI** *src3, dst2*

Operands *src_count*: register (R0 – R7)
src2: indirect (disp = 0, 1, IR0, IR1)
dst1: register (R0 – R7)
src3: register (R0 – R7)
dst2: indirect (disp = 0, 1, IR0, IR1)

Opcode

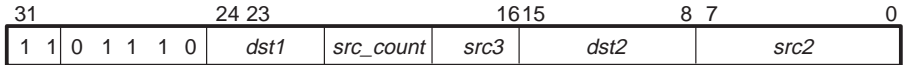

Word Fields None

Operation *count* = 7 LSBs of *src_count*
 If *count* ≥ 0:
 src2 << *count* → *dst1*
 Else:
 src2 >> |*count*| → *dst1*
 || *src3* → *dst2*

Description The seven LSBs of the *src_count* operand constitute the 2s-complement shift *count*.

If *count* is greater than 0, a copy of the *src2* operand is left-shifted by the value of *count* and the result is written to *dst1* (*src2* is not changed). Low-order bits shifted in are zero-filled, and high-order bits are shifted out through the C (carry) bit.

Logical left-shift:

$$C \leftarrow src2 \leftarrow 0$$

If *count* is less than 0, a copy of the *src2* operand is right-shifted by the absolute value of *count*. The high-order bits of the *dst* operand are zero-filled as shifted to the right. Low-order bits are shifted out through the C (carry bit).

Logical right-shift:

$$0 \rightarrow src2 \rightarrow C$$

If *count* is 0, no shift is performed and the carry bit is set to 0.

The *src_count* operand is assumed to be a signed integer, and the *src2* and *dst1* operands are assumed to be unsigned integers. All registers are read at the beginning and loaded at the end of the execute cycle. This means that if one of the parallel operations (STI) reads from a register and the operation be-

ing performed in parallel (LSH3) writes to the same register, then STI accepts as input the contents of the register before it is modified by the LSH3.

If *src2* and *dst2* point to the same location, *src2* is read before the write to *dst2*.

Status Bits

LUF Unaffected
LV Unaffected
UF 0
N MSB of the output
Z 1 if a zero output is generated, 0 otherwise
V 0
C Set to the value of the last bit shifted out. 0 for a shift *count* of 0

Mode Bit

OVM operation is affected by OVM bit value.

Cycles

1

Example 1

```
    LSH3    R2, *++AR3(1), R0
||   STI    R4, *-AR5
```

Before Instruction		After Instruction			
R2	18h	24	R2	18h	24
AR3	8098C2h		AR3	8098C3h	
R0	0h		R0	0AC00 0000h	
R4	0DCh	220	R4	0DCh	220
AR5	80 98A3h		AR5	80 98A3h	
Data at 80 98C3h	0ACh		Data at 80 98C3h	0ACh	
Data at 80 98A2h	0h		Data at 80 98A2h	0DCh	220
LUF	0		LUF	0	
LV	0		LV	0	
UF	0		UF	0	
N	0		N	1	
Z	0		Z	0	
V	0		V	0	
C	0		C	0	

Example 2

```

    LSH3    R7, *AR2--(1), R2
||   STI    R0, *+AR0(1)

```

Before Instruction		After Instruction			
R7	0FFFFFFF4h	-12	R7	0FFFFFFF4h	-12
AR2	80 9863h		AR2	80 9862h	
R2	0h		R2	2C000h	
R0	12Ch	300	R0	12Ch	300
AR0	80 98B7h		AR0	80 98B7h	
Data at 80 9863h			Data at 80 9863h		
	2C00 0000h			2C00 0000h	
Data at 80 98B9h			Data at 80 98B8h		
	0h			12Ch	300
LUF	0		LUF	0	
LV	0		LV	0	
UF	0		UF	0	
N	0		N	1	
Z	0		Z	0	
V	0		V	0	
C	0		C	0	

Syntax **LWLct** *src*, *dst*

Operands
ct: the count of bytes {0, 1, 2, or 3} to shift left ($ct \times 8 = \text{shift in bits}$)
src: register, direct, 16-bit immediate-, or indirect- addressing modes
dst: register mode (any register in CPU primary-register file)

Opcode

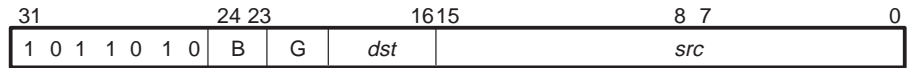

Word Fields

G	<i>src</i> addressing modes
00	register (any register in CPU primary register file)
01	direct
10	indirect
11	immediate

B	<i>src</i> byte
00	no shift
01	shift left 1 byte space
10	shift left 2-byte spaces
11	shift left 3-byte spaces

Operation $src \ll \{0, 1, 2, \text{ or } 3\} \text{ bytes and merged with } dst \rightarrow dst$

Description The *src* operand is left-shifted the specified number of bytes and merged with the bytes of the *dst* register that are below the left-shifted LSB of the *src* operand. When immediate mode is selected, this instruction performs a sign extension of the 16-bit immediate value into a 32-bit value; then, this 32-bit value is shifted and merged.

Status Bits

If ST (SET COND) = 0 and the destination register is R0 – R11, the condition flags are modified. If ST (SET COND) = 1, they are modified for all destination registers.

- LUF** Unaffected
- LV** Unaffected
- UF** 0
- N** MSB of the output
- Z** 1 if a zero result is generated, 0 otherwise
- V** 0
- C** Unaffected

Mode Bit

OVM operation is not affected by OVM bit value.

Cycles

1

Example

LWL2 R1, R2

	Before Instruction	After Instruction		
R1	<table border="1"><tr><td>ABCD EF12h</td></tr></table>	ABCD EF12h	<table border="1"><tr><td>ABCD EF12h</td></tr></table>	ABCD EF12h
ABCD EF12h				
ABCD EF12h				
R2	<table border="1"><tr><td>1234 5678h</td></tr></table>	1234 5678h	<table border="1"><tr><td>EF12 5678h</td></tr></table>	EF12 5678h
1234 5678h				
EF12 5678h				

Syntax **LWRct** *src, dst*

Operands
ct: the count of bytes {0, 1, 2, or 3} to shift right ($ct \times 8 =$ shift in bits)
src: register, direct, 16-bit immediate-, or indirect-addressing modes
dst: register mode (any register in CPU primary-register file)

Opcode

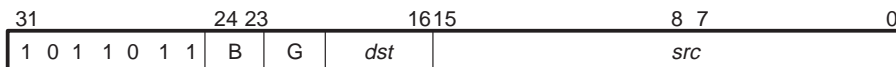

Word Fields

G	<i>src</i> addressing modes
00	register (any register in CPU primary-register file)
01	direct
10	indirect
11	immediate

B	<i>src</i> byte
00	no shift
01	shift left 1 byte space
10	shift left 2-byte spaces
11	shift left 3-byte spaces

Operation *src* >> {0, 1, 2, or 3} bytes and merged with *dst* → *dst*

Description The *src* operand is right-shifted the specified number of bytes and merged with the bytes of the *dst* register that are above the right-shifted MSB of the *src* operand. Sign is not extended. When immediate mode is selected, this instruction performs a sign extension of the 16-bit immediate value into a 32-bit value; then, this 32-bit value is shifted and merged.

Status Bits

If ST (SET COND) = 0 and the destination register is R0 – R11, the condition flags are modified. If ST (SET COND) = 1, they are modified for all destination registers.

- LUF** Unaffected
- LV** Unaffected
- UF** 0
- N** MSB of the output
- Z** 1 if a zero result is generated, 0 otherwise
- V** 0
- C** Unaffected

Mode Bit

OVM operation is not affected by OVM bit value.

Cycles

1

Example

LWR1 AR1, R2

	Before Instruction	After Instruction
AR1	ABCD EF12hEF	ABCD EF12h
R2	1234 5678h	12AB CDEFh

Syntax **MBct** *src, dst*

Operands
ct: the count of bytes {0, 1, 2, 3} to shift left ($ct \times 8 =$ shift in bits)
src: register-, direct-, or indirect-addressing modes
dst: register mode (any register in CPU primary-register file)

Opcode

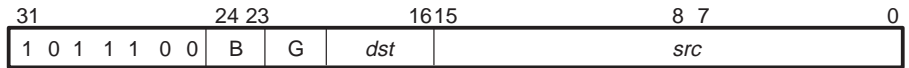

Word Fields

G	<i>src</i> addressing modes
00	register (any register in CPU primary-register file)
01	direct
10	indirect
11	immediate

B	<i>src</i> byte
00	no shift
01	shift left 1 byte space
10	shift left 2-byte spaces
11	shift left 3-byte spaces

Operation 8 LSBs of *src* \ll {0, 1, 2, or 3} bytes and merged with *dst* \rightarrow *dst*

Description The eight LSBs of the *src* operand are left shifted 0, 1, 2, or 3 bytes and merged with the bits of the *dst* register that are below the left-shifted LSB of the *src* operand. When immediate mode is selected, this instruction performs a sign extension of the 16-bit immediate value into a 32-bit value; then, this 32-bit value is shifted and merged.

Status Bits

If ST (SET COND) = 0 and the destination register is R0 – R11, the condition flags are modified. If ST (SET COND) = 1, they are modified for all destination registers.

LUF Unaffected
LV Unaffected
UF 0
N MSB of the output
Z 1 if a zero result is generated, 0 otherwise
V 0
C Unaffected

Mode Bit

OVM operation is not affected by OVM bit value.

Cycles

1

Example

MB2 AR1, AR2

	Before Instruction		After Instruction		
AR1	<table border="1"><tr><td>ABCD EF12h</td></tr></table> (0012 0000h)	ABCD EF12h		AR1 <table border="1"><tr><td>ABCD EF12h</td></tr></table>	ABCD EF12h
ABCD EF12h					
ABCD EF12h					
AR2	<table border="1"><tr><td>1234 5678h</td></tr></table>	1234 5678h		AR2 <table border="1"><tr><td>1212 5678h</td></tr></table>	1212 5678h
1234 5678h					
1212 5678h					

Syntax **MHct** *src, dst*

Operands
ct: the count of half-word (16-bit) shifts
src: register-, direct-, 16-bit immediate-, or indirect-addressing modes
dst: register mode (any register in CPU primary-register file)

Opcode

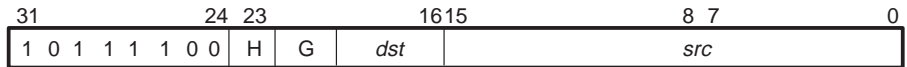

Word Fields

G	<i>src</i> addressing modes
00	register (any register in CPU primary-register file)
01	direct
10	indirect
11	immediate

H	<i>src</i> half-word
0	half-word 0 (LS half-word)
1	half-word 1 (MS half-word)

Operation 16 LSBs of *src* \ll {0, 1} half-words and merged with *dst* \rightarrow *dst*

Description The 16 LSBs of the *src* operand are left shifted 0 or 1 half-words and merged with the bits of the *dst* register that are below the left-shifted LSB of the *src* operand. When immediate mode is selected, this instruction performs a sign extension of the 16-bit immediate value into a 32-bit value; then, this 32-bit value is shifted and merged.

Status Bits If ST (SET COND) = 0 and the destination register is R0–R11, the condition flags are modified. If ST (SET COND) = 1, they are modified for all destination registers.

LUF Unaffected
LV Unaffected
UF 0
N MSB of the output
Z 1 if a zero result is generated, 0 otherwise
V 0
C Unaffected

Mode Bit **OVM** operation is not affected by OVM bit value.

Cycles 1

Example MH1 AR1 , AR2

	Before Instruction		After Instruction
AR1	ABCD EF12h	(EF12 0000h)	AR1 ABCD EF12h
AR2	1234 5678h		AR2 EF12 5678h

Syntax **MPYF** *src, dst*

Operands *src*: general-addressing modes (G)
dst: register (R0 – R11)

Opcode

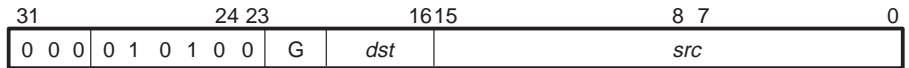

Word Fields

G	<i>src</i> addressing modes
00	register (R0–R11)
01	direct
10	indirect
11	immediate

Operation $dst \times src \rightarrow dst$

Description The product of the *dst* and *src* operands is loaded into the *dst* register. The values at *src* (if in register mode (R0–R11)) and *dst* are treated as extended-precision floating-point numbers. For nonregister mode, *src* is treated as single-precision floating-point number.

Status Bits

LUF 1 if a floating-point underflow occurs, unchanged otherwise
LV 1 if a floating-point overflow occurs, unchanged otherwise
UF 1 if a floating-point underflow occurs, 0 otherwise
N 1 if a negative result is generated, 0 otherwise
Z 1 if a zero result is generated, 0 otherwise
V 1 if a floating-point is overflow occurs, 0 otherwise
C Unaffected.

Mode Bit **OVM** operation is not affected by OVM bit value.

Cycles 1

Example

MPYF R0, R2

Before Instruction		After Instruction	
R0	<input type="text" value="07 0C80 0000h"/> 1.4050e + 02	R0	<input type="text" value="07 0C80 0000h"/> 1.4050e + 02
R2	<input type="text" value="03 4C20 0000h"/> 1.27578125e + 01	R2	<input type="text" value="0A 600F 2000h"/> 1.79247266e + 03
LUF	<input type="text" value="0"/>	LUF	<input type="text" value="0"/>
LV	<input type="text" value="0"/>	LV	<input type="text" value="0"/>
UF	<input type="text" value="0"/>	UF	<input type="text" value="0"/>
N	<input type="text" value="0"/>	N	<input type="text" value="0"/>
Z	<input type="text" value="0"/>	Z	<input type="text" value="0"/>
V	<input type="text" value="0"/>	V	<input type="text" value="0"/>
C	<input type="text" value="0"/>	C	<input type="text" value="0"/>

You can code any combination of addressing modes for the four possible source operands as long as you code two as indirect and two as register. The assignment of the source operands *srcA* – *srcD* to the *src1* – *src4* fields varies, depending on the combination of addressing modes used; the P field is encoded accordingly. The assembler may, when not significant, change the order of operands in commutative operations to simplify processing.

If *src2* and *dst2* point to the same location, *src2* is read before the write to *dst2*.

Status Bits

LUF 1 if a floating-point underflow occurs, unchanged otherwise
LV 1 if a floating-point overflow occurs, unchanged otherwise
UF 1 if a floating-point underflow occurs, 0 otherwise
N 0
Z 0
V 1 if a floating-point overflow occurs, 0 otherwise
C Unaffected

Mode Bit

OVM operation is not affected by OVM bit value.

Cycles

1

Example

```
MPYF3 *AR5++(1), *- - AR1(IR0), R0
|| ADDF3 R5, R7, R3
```

Before Instruction		After Instruction	
AR5	80 98C5h	AR5	80 98C6h
AR1	80 98A8h	AR1	80 98A4h
IR0	4h	IR0	4h
R0	0h	R0	04 6718 000h 2.88867188e + 01
R5	07 33C0 0000h 1.79750e + 02	R5	07 33C0 0000h 1.79750e + 02
R7	07 0C80 0000h 1.4050e + 02	R7	07 0C80 0000h 1.4050e + 02
R3	0h	R3	08 2020 0000h 3.20250e + 02
Data at 80 98C5h	34C 0000h 1.2750e + 01	Data at 80 98C5h	34C 0000h 1.2750e + 01
Data at 80 98A4h	111 0000h 2.265625e + 0	Data at 80 98A4h	111 0000h 2.265625e + 0
LUF	0	LUF	0
LV	0	LV	0
UF	0	UF	0
N	0	N	0
Z	0	Z	0
V	0	V	0
C	0	C	0

Syntax **MPYF3** *src2, src1, dst1*
 || **STF** *src3, dst2*

Operands *src1*: register (R0 – R7)
 src2: indirect (disp = 0, 1, IR0, IR1)
 dst1: register (R0 – R7)
 src3: register (R0 – R7)
 dst2: indirect (disp = 0, 1, IR0, IR1)

Opcode

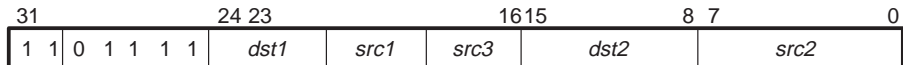

Word Fields None

Operation $src1 \times src2 \rightarrow dst1$
 || $src3 \rightarrow dst2$

Description A floating-point multiplication and a floating-point store are performed in parallel. All registers are read at the beginning and loaded at the end of the execute cycle. This means that if one of the parallel operations (MPYF3) writes to a register and the operation being performed in parallel (STF) reads from the same register, then the STF accepts as input the contents of the register before it is modified by the MPYF3.

If *src2* and *dst2* point to the same location, then *src2* is read before the write to *dst2*.

Status Bits **LUF** 1 if a floating-point underflow occurs, 0 unchanged otherwise
 LV 1 if a floating-point overflow occurs, unchanged otherwise
 UF 1 if a floating-point underflow occurs, 0 otherwise
 N 1 if a negative result is generated, 0 otherwise
 Z 1 if a zero result is generated, 0 otherwise
 V 1 if a floating-point overflow occurs, 0 otherwise
 C Unaffected

Mode Bit **OVM** operation is not affected by OVM bit value.

Cycles 1

Example

```
MPYF3 *-AR2(1),R7,R0
|| STF R3,*AR0--(IR0)
```

Before Instruction		After Instruction	
AR2	<input type="text" value="80 982Bh"/>	AR2	<input type="text" value="80 982Bh"/>
R7	<input type="text" value="05 7B40 0000h"/> 6.281250e + 01	R7	<input type="text" value="05 7B40 0000h"/> 6.281250e + 01
R0	<input type="text" value="0h"/>	R0	<input type="text" value="0D 09E4 A000h"/> 8.82515625e + 03
R3	<input type="text" value="08 6B28 0000h"/> 4.7031250e + 02	R3	<input type="text" value="08 6B28 0000h"/> 4.7031250e + 02
AR0	<input type="text" value="80 9860h"/>	AR0	<input type="text" value="80 9858h"/>
IR0	<input type="text" value="8h"/>	IR0	<input type="text" value="8h"/>
Data at 80 982Ah	<input type="text" value="70C 8000h"/> 1.4050e + 02	Data at 80 982Ah	<input type="text" value="70C 8000h"/> 1.4050e + 02
Data at 80 9860h	<input type="text" value="0h"/>	Data at 80 9860h	<input type="text" value="86B28 0000h"/> 4.7031250e + 02
LUF	<input type="text" value="0"/>	LUF	<input type="text" value="0"/>
LV	<input type="text" value="0"/>	LV	<input type="text" value="0"/>
UF	<input type="text" value="0"/>	UF	<input type="text" value="0"/>
N	<input type="text" value="0"/>	N	<input type="text" value="0"/>
Z	<input type="text" value="0"/>	Z	<input type="text" value="0"/>
V	<input type="text" value="0"/>	V	<input type="text" value="0"/>
C	<input type="text" value="0"/>	C	<input type="text" value="0"/>

Syntax

```

MPYF3  srcA, srcB, dst1
|| SUBF3  srcC, srcD, dst2

```

$\left. \begin{array}{l} \textit{srcA} \\ \textit{srcB} \\ \textit{srcC} \\ \textit{srcD} \end{array} \right\}$ Any two must be indirect (disp = 0, 1, IR0, IR1), and any two must be register (R0 – R7).

Operands

None

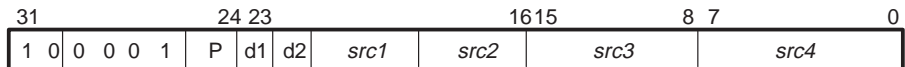
Opcode

Word Fields

None

Operation

```

srcA × srcB → dst1
|| srcD – srcC → dst2

```

dst1 register (*d1*):
 0 = R0
 1 = R1

dst2 register (*d2*):
 0 = R2
 1 = R3

src1 register (R0 – R7)
src2 register (R0 – R7)
src3 indirect (disp = 0, 1, IR0, IR1)
src4 indirect (disp = 0, 1, IR0, IR1)

P parallel-addressing modes (0 ≤ P ≤ 3)

Operation (P Field)

00 *src3* × *src4*, *src1* – *src2*
 01 *src3* × *src1*, *src4* – *src2*
 10 *src1* × *src2*, *src3* – *src4*
 11 *src3* × *src1*, *src2* – *src4*

Description

A floating-point multiplication and a floating-point subtraction are performed in parallel. All registers are read at the beginning and loaded at the end of the execute cycle. This means that if one of the parallel operations (MPYF3) reads from a register, and the operation being performed in parallel (SUBF3) writes to the same register, then MPYF3 accepts as input the contents of the register before it is modified by the SUBF3.

You can code any combination of addressing modes for the four possible source operands as long as you code two as indirect and two as register. The assignment of the source operands *srcA* – *srcD* to the *src1* – *src4* fields varies, depending on the combination of addressing modes used; the P field is encoded accordingly. The assembler may, when not significant, change the order of operands in commutative operations to simplify processing.

Status Bits

LUF 1 if a floating-point underflow occurs, unchanged otherwise
LV 1 if a floating-point overflow occurs, unchanged otherwise
UF 1 if a floating-point underflow occurs, 0 otherwise
N 0
Z 0
V 1 if a floating-point overflow occurs, 0 otherwise
C Unaffected

Mode Bit

OVM operation is not affected by OVM bit value.

Cycles

1

Example

```
MPYF3 R5, *++AR7( IR1 ), R0
|| SUBF3 R7, *AR3--( 1 ), R2
or
MPYF3 *++AR7( IR1 ), R5, R0
|| SUBF3 R7, *AR3--( 1 ), R2
```

Before Instruction		After Instruction	
R5	03 4C00 0000h 1.2750e + 01	R5	03 4C00 0000h 1.2750e + 01
AR7	80 9904h	AR7	80 990Ch
IR1	8h	IR1	8h
R0	0h	R0	04 6718 0000h 2.88867188e + 01
R7	07 33C0 0000h 1.79750e + 02	R7	07 33C0 0000h 1.79750e + 02
AR3	80 98B2h	AR3	80 98B1h
R2	0h	R2	05 E300 0000h -3.9250e + 01
Data at 80 990Ch	111 0000h 2.250e + 00	Data at 80 990Ch	111 0000h 2.250e + 00
Data at 80 98B2h	70C 8000h 1.4050e + 02	Data at 80 98B2h	70C 8000h 1.4050e + 02
LUF	0	LUF	0
LV	0	LV	0
UF	0	UF	0
N	0	N	0
Z	0	Z	0
V	0	V	0
C	0	C	0

Syntax **MPYI** *src, dst*

Operands
src: general-addressing modes (G)
dst: register (any register in CPU primary-register file)

Opcode

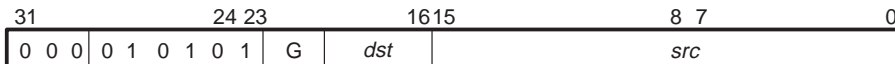

Word Fields

G	src addressing modes
00	register (any register in CPU primary-register file)
01	direct
10	indirect
11	immediate

Operation $dst \times src \rightarrow dst$

Description The product of the *dst* and *src* operands is loaded into the *dst* register. The *src* and *dst* operands, when read, are assumed to be 32-bit signed integers. The result is assumed to be a 64-bit signed integer. The output to the *dst* register is the 32 LSBs of the result.

Integer overflow occurs when any of the 32 MSBs of the 64-bit result differs from the MSB of the 32-bit output value.

Status Bits If ST (SET COND) = 0 and the destination register is R0 – R11, the condition flags are modified. If ST (SET COND) = 1, they are modified for all destination registers.

- LUF** Unchanged
- LV** 1 if an integer overflow occurs, unchanged otherwise
- UF** 0
- N** 1 if a negative result is generated, 0 otherwise
- Z** 1 if a zero result is generated, 0 otherwise
- V** 1 if an integer overflow occurs, 0 otherwise
- C** Unaffected

Mode Bit **OVM** operation is affected by OVM bit value.

Cycles 1

Example

MPYI R1,R5

Before Instruction		After Instruction	
R1	00 0033 C251h 3 392 081	R1	00 0033 C251h 3 392 081
R5	00 0078 B600h 7 910 912	R5	00 E21D 9600h -501 377 536
LUF	0	LUF	0
LV	0	LV	1
UF	0	UF	0
N	0	N	1
Z	0	Z	0
V	0	V	1
C	0	C	0

The result overflows and R5 contains the 32 LSBs of the result. To obtain the 32 MSBs, use the MPYSHI3 or the MPYUHI3 instructions.

Syntax **MPYI3** *src2, src1, dst*

Operands *src1, src2*: type 1 or type 2 three-operand addressing modes
dst: register mode (any register in CPU primary-register file)

Opcode

Type 1

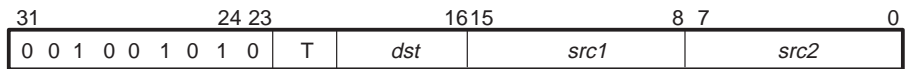

Type 2

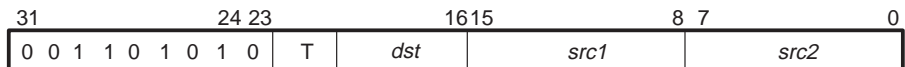

Word Fields

Type 1

	T <i>src1</i> addressing modes	<i>src2</i> addressing modes
00	register mode (any CPU register)	register mode (any CPU register)
01	indirect mode (disp = 0, 1, IR0, IR1)	register mode (any CPU register)
10	register mode (any CPU register)	indirect mode (disp = 0, 1, IR0, IR1)
11	indirect mode (disp = 0, 1, IR0, IR1)	indirect mode (disp = 0, 1, IR0, IR1)

Type 2

	T <i>src1</i> addressing modes	<i>src2</i> addressing modes
00	register mode (any CPU register)	8-bit signed immediate
01	register mode (any CPU register)	indirect mode *+ARn(5-bit unsigned displacement)
10	indirect mode *+ARn(5-bit unsigned displacement)	8-bit signed immediate
11	indirect mode *+ARn1(5-bit unsigned displacement)	indirect mode *+ARn2(5-bit unsigned displacement)

Operation $src1 \times src2 \rightarrow dst$

Description The product of the numbers at *src1* and *src2* is loaded into the *dst* register. The multiplied numbers are assumed to be 32-bit signed integers. The result is assumed to be a signed 64-bit integer. The output to the *dst* register is the 32 least-significant bits of the result.

Integer overflow occurs when any of the 32 MSBs of the 64-bit result differs from the MSB of the 32-bit *dst* value.

Status Bits	If ST (SET COND) = 0 and the destination register is R0 – R11, the condition flags are modified. If ST (SET COND) = 1, they are modified for all destination registers. LUF Unchanged. LV 1 if an integer overflow occurs, unchanged otherwise UF 0 N 1 if a negative result is generated, 0 otherwise Z 1 if a zero result is generated, 0 otherwise V 1 if an integer overflow occurs, 0 otherwise C Unaffected
Mode Bit	OVM operation is affected by OVM bit value.
Cycles	1
Example	None

You can code any combination of addressing modes for the four possible source operands as long as you code two as indirect and two as register. The assignment of the source operands *srcA* – *srcD* to the *src1* – *src4* fields varies, depending on the combination of addressing modes used; the P field is encoded accordingly. The assembler may, when not significant, change the order of operands in commutative operations to simplify processing.

Status Bits

LUF Unchanged
LV 1 if an integer overflow occurs, unchanged otherwise
UF 0
N 0
Z 0
V 1 if an integer overflow occurs, 0 otherwise
C Unaffected

Mode Bit

OVM operation is affected by OVM bit value.

Cycles

1

Example

```
MPYI3 R7,R4,R0
|| ADDI3 *-AR3,*AR5--(1),R3
```

Before Instruction			After Instruction		
R7	14h	20	R7	14h	20
R4	64h	100	R4	64h	100
R0	0h		R0	07D0h	2000
AR3	80 981Fh		AR3	80 981Fh	
AR5	80 996Eh		AR5	80 996Dh	
R3	0h		R3	0h	
Data at 80 981Eh	0FFFF FFCBh	-53	Data at 80 981Eh	0FFFF FFCBh	-53
Data at 80 996Eh	35h	53	Data at 80 996Eh	35h	53
LUF	0		LUF	0	
LV	0		LV	0	
UF	0		UF	0	
N	0		N	0	
Z	0		Z	0	
V	0		V	0	
C	0		C	0	

Syntax **MPYI3** *src2, src1, dst1*
 || **STI** *src3, dst2*

Operands *src1*: register (R0 – R7)
 src2: indirect (disp = 0, 1, IR0, IR1)
 dst1: register (R0 – R7)
 src3: register (R0 – R7)
 dst2: indirect (disp = 0, 1, IR0, IR1)

Opcode

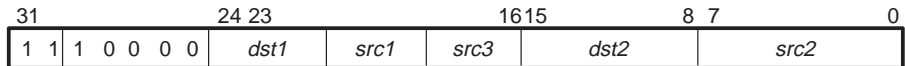

Word Fields None

Operation *src1* × *src2* → *dst1*
 || *src3* → *dst2*

Description An integer multiplication and an integer store are performed in parallel. All registers are read at the beginning and loaded at the end of the execute cycle. This means that if one of the parallel operations (STI) reads from a register and the operation being performed in parallel (MPYI3) writes to the same register, then STI accepts as input the contents of the register before it is modified by the MPYI3.

If *src2* and *dst2* point to the same location, *src2* is read before the write to *dst2*.

Integer overflow occurs when any of the 32 MSBs of the 64-bit result differs from the most significant bit of the 32-bit *dst1* value.

Status Bits **LUF** Unchanged
LV 1 if an integer overflow occurs, unchanged otherwise
UF 0
N 1 if a negative result is generated, 0 otherwise
Z 1 if a zero result is generated, 0 otherwise
V 1 if an integer overflow occurs, 0 otherwise
C Unaffected

Mode Bit **OVM** operation is affected by OVM bit value.

Cycles 1

Example

```
MPYI3  *++AR0(1),R5,R7
|| STI  R2,*-AR3(1)
```

Before Instruction		After Instruction			
AR0	80 995Ah	AR0	80 995Bh		
R5	32h	50	R5	32h	50
R7	0h		R7	2710h	10000
R2	0DCh	220	R2	0DCh	220
AR3	80 982Fh		AR3	80 982Fh	
Data at 80 995Bh	0C8h	200	Data at 80 995Bh	0C8h	200
Data at 80 982Eh	0h		Data at 80 982Eh	0DCh	220
LUF	0		LUF	0	
LV	0		LV	0	
UF	0		UF	0	
N	0		N	0	
Z	0		Z	0	
V	0		V	0	
C	0		C	0	

assignment of the source operands *srcA*–*srcD* to the *src1*–*src4* fields varies, depending on the combination of addressing modes used; the P field is encoded accordingly. The assembler may, when not significant, change the order of operands in commutative operations in order to simplify processing.

Integer overflow occurs when any of the 32 MSBs of the 64-bit result differs from the MSB of the 32-bit output value.

Status Bits

LUF Unchanged
LV 1 if an integer overflow occurs, unchanged otherwise
UF 1 if an integer underflow occurs, 0 otherwise
N 0
Z 0
V 1 if an integer overflow occurs, 0 otherwise
C Unaffected

Mode Bit

OVM operation is affected by OVM bit value.

Cycles

1

Example

```
MPYI3 R2, *++AR0(1), R0
|| SUBI3 *AR5--(IR1), R4, R2
or
MPYI3 *++AR0(1), R2, R0
|| SUBI3 *AR5--(IR1), R4, R2
```

Before Instruction		After Instruction		
R2	32h	50	320h	800
AR0	80 98E3h		80 98E4h	
R0	0h		01324h	4900
AR5	80 99FCh		80 99F0h	
IR1	0Ch		0Ch	
R4	07D0h	2000	07D0h	2000
Data at 80 98E4h	62h	98	62h	98
Data at 80 99FCh	4B0h	1200	4B0h	1200
LUF	0		0	
LV	0		0	
UF	0		0	
N	0		0	
Z	0		0	
V	0		0	
C	0		0	

Syntax **MPYSHI** *src, dst*

Operands *src*: general-addressing modes
dst: register mode (any register in CPU primary-register file)

Opcode

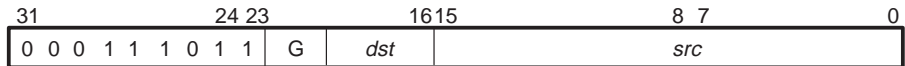

Word Fields

G	<i>src</i> addressing modes
00	register (any register in CPU primary-register file)
01	direct
10	indirect
11	immediate

Operation $dst \times src \rightarrow dst$

Description The 32 MSBs of the product of the numbers at *dst* and *src* are loaded into the *dst* register. These numbers, when read, are assumed to be signed 32-bit integers. The result is assumed to be a signed 64-bit integer. The output to the *dst* register is the 32 MSBs of the result. The MPYI instruction provides the 32 LSBs of the result.

Status Bits If ST (SET COND) = 0 and the destination register is R0–R11, the condition flags are modified. If ST (SET COND) = 1, they are modified for all destination registers.

- LUF** Unchanged
- LV** Unchanged
- UF** 0
- N** 1 if a negative result is generated, 0 otherwise
- Z** 1 if all 64 bits of the product are 0, 0 otherwise
- V** 0
- C** Unaffected

Mode Bit **OVM** operation is not affected by OVM bit value.

Cycles 1

Example None

Syntax **MPYSHI3** *src2, src1, dst*

Operands
src1: type 1 or type 2 three-operand addressing modes
src2: type 1 or type 2 three-operand addressing modes
dst: register mode (any register in CPU primary-register file)

Opcode

Type 1

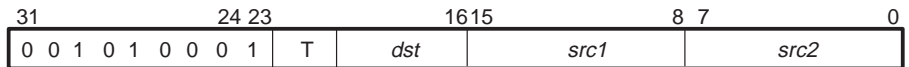

Type 2

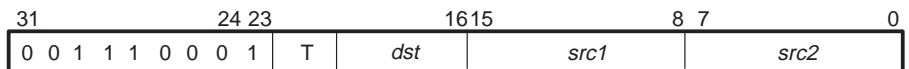

Word Fields

Type 1

	T	<i>src1</i> addressing modes	<i>src2</i> addressing modes
	00	register mode (any CPU register)	register mode (any CPU register)
	01	indirect mode (disp = 0, 1, IR0, IR1)	register mode (any CPU register)
	10	register mode (any CPU register)	indirect mode (disp = 0, 1, IR0, IR1)
	11	indirect mode (disp = 0, 1, IR0, IR1)	indirect mode (disp = 0, 1, IR0, IR1)

Type 2

	T	<i>src1</i> addressing modes	<i>src2</i> addressing modes
	00	register mode (any CPU register)	8-bit signed immediate
	01	register mode (any CPU register)	indirect mode *+ARn(5-bit unsigned displacement)
	10	indirect mode *+ARn(5-bit unsigned displacement)	8-bit signed immediate
	11	indirect mode *+ARn1(5-bit unsigned displacement)	indirect mode *+ARn2(5-bit unsigned displacement)

Operation

$src1 \times src2 \rightarrow dst$

Description

The product of the numbers at the *src1* and *src2* operands is loaded into the *dst* register. The numbers at the *src1* and *src2* operands are assumed to be 32-bit signed integers. The result is assumed to be a signed 64-bit integer. The output to the *dst* register is the 32 MSBs of the result. The MPYI3 instruction provides the 32 LSBs of the result.

Status Bits	<p>If ST (SET COND) = 0 and the destination register is R0–R11, the condition flags are modified. If ST (SET COND) = 1, they are modified for all destination registers.</p> <p>LUF Unchanged LV 1 if an integer overflow occurs, unchanged otherwise UF 0 N 1 if a negative result is generated, 0 otherwise Z 1 if a zero result is generated, 0 otherwise V 1 if an integer overflow occurs, 0 otherwise C Unaffected</p>
Mode Bit	<p>OVM operation is not affected by OVM bit value.</p>
Cycles	1
Example	None

Syntax **MPYUHI** *src, dst*

Operands *src*: general-addressing modes
dst: register mode (any register in CPU primary-register file)

Opcode

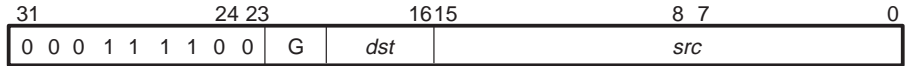

Word Fields

G	<i>src</i> addressing modes
00	register (any register in CPU primary-register file)
01	direct
10	indirect
11	immediate

Operation $dst \times src \rightarrow dst$

Description The 32 MSBs of the product of the numbers at *dst* and *src* operands are loaded into the *dst* register. These numbers, when read, are assumed to be unsigned 32-bit integers. The result is assumed to be an unsigned 64-bit integer. The output to the *dst* register is the 32 MSBs of the result. The MPYI instruction provides the 32 LSBs of the result.

Status Bits If ST (SET COND) = 0 and the destination register is R0 – R11, the condition flags are modified. If ST (SET COND) = 1, they are modified for all destination registers.

- LUF** Unchanged
- LV** Unchanged
- UF** 0
- N** 0
- Z** 1 if all 64 bits of the product are 0, 0 otherwise
- V** 0
- C** Unaffected

Mode Bit **OVM** operation is not affected by OVM bit value.

Cycles 1

Example None

Syntax **MPYUH3** *src2, src1, dst*

Operands *src1, src2*: both type 1 or type 2 three-operand addressing modes
dst: register mode (any register in CPU primary-register file)

Opcod

Type 1

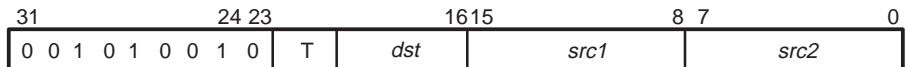

Type 2

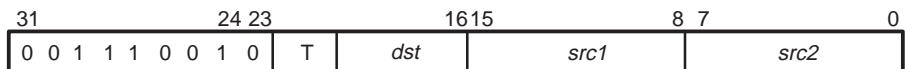

Word Fields

Type 1

T	<i>src1</i> addressing modes	<i>src2</i> addressing modes
00	register mode (any CPU register)	register mode (any CPU register)
01	indirect mode (disp = 0, 1, IR0, IR1)	register mode (any CPU register)
10	register mode (any CPU register)	indirect mode (disp = 0, 1, IR0, IR1)
11	indirect mode (disp = 0, 1, IR0, IR1)	indirect mode (disp = 0, 1, IR0, IR1)

Type 2

T	<i>src1</i> addressing modes	<i>src2</i> addressing modes
00	register mode (any CPU register)	8-bit signed immediate
01	register mode (any CPU register)	indirect mode *+ARn(5-bit unsigned displacement)
10	indirect mode *+ARn(5-bit unsigned displacement)	8-bit signed immediate
11	indirect mode *+ARn1(5-bit unsigned displacement)	indirect mode *+ARn2(5-bit unsigned displacement)

Operation $src1 \times src2 \rightarrow dst$

Description The product of the numbers at the *src1* and *src2* operands is loaded into the *dst* register. The numbers at the *src1* and *src2* operands are assumed to be 32-bit signed integers. The result is assumed to be an unsigned 64-bit integer. The output to the *dst* register is the 32 MSBs of the result. The MPYI3 instruction provides the 32 LSBs of the result.

Status Bits	<p>If ST (SET COND) = 0 and the destination register is R0 – R11, the condition flags are modified. If ST (SET COND) = 1, they are modified for all destination registers.</p> <p>LUF Unchanged LV Unchanged UF 0 N 0 Z 1 if all 64 bits of the product are 0, 0 otherwise V 0 C Unaffected</p>
Mode Bit	OVM operation is not affected by OVM bit value.
Cycles	1
Example	None

Syntax **NEGB** *src, dst*

Operands *src*: general-addressing modes (G)
 dst: register (any register in CPU primary-register file)

Opcode

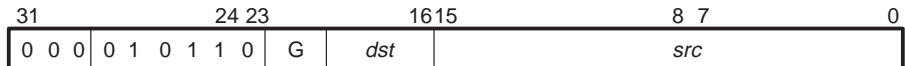

Word Fields

G	<i>src</i> addressing modes
00	register (any register in CPU primary-register file)
01	direct
10	indirect
11	immediate

Operation $0 - src - C \rightarrow dst$

Description The difference of the 0, *src*, and C operands, calculated as shown, is loaded into the *dst* register. The *dst* and *src* are assumed to be signed integers.

Status Bits If ST (SETCOND) = 0 and the destination register is R0 – R11, the condition flags are modified. If ST (SETCOND) = 1, they are modified for all destination registers.

- LUF** Unaffected
- LV** 1 if an integer overflow occurs, unchanged otherwise
- UF** 0
- N** 1 if a negative result is generated, 0 otherwise
- Z** 1 if a zero result is generated, 0 otherwise
- V** 1 if an integer overflow occurs, 0 otherwise
- C** 1 if a borrow occurs, 0 otherwise

Mode Bit **OVM** operation is affected by OVM bit value.

Cycles 1

Example

NEGB R5,R7

		Before Instruction		After Instruction		
R5	<input type="text" value="0FFFF FFCBh"/>		-53	R5	<input type="text" value="0FFFF FFCBh"/>	-53
R7	<input type="text" value="0h"/>			R7	<input type="text" value="34h"/>	52
LUF	<input type="text" value="0"/>			LUF	<input type="text" value="0"/>	
LV	<input type="text" value="0"/>			LV	<input type="text" value="0"/>	
UF	<input type="text" value="0"/>			UF	<input type="text" value="0"/>	
N	<input type="text" value="0"/>			N	<input type="text" value="0"/>	
Z	<input type="text" value="0"/>			Z	<input type="text" value="0"/>	
V	<input type="text" value="0"/>			V	<input type="text" value="0"/>	
C	<input type="text" value="1"/>			C	<input type="text" value="1"/>	

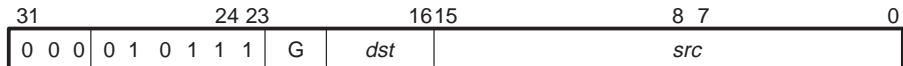
Syntax **NEGF** *src, dst***Operands** *src*: general-addressing modes (G)
dst: register (R0 – R11)**Opcode****Word Fields**

G	<i>src</i> addressing modes
00	register (any register in CPU primary-register file)
01	direct
10	indirect
11	immediate

Operation $0 - src \rightarrow dst$ **Description** The difference of the 0 and *src* operands is loaded into the *dst* register. The *dst* and *src* operands are assumed to be floating-point numbers.**Status Bits** **LUF** 1 if a floating-point underflow occurs, unchanged otherwise
LV 1 if a floating-point overflow occurs, unchanged otherwise
UF 1 if a floating-point underflow occurs, 0 otherwise
N 1 if a negative result is generated, 0 otherwise
Z 1 if a zero result is generated, 0 otherwise
V 1 if a floating-point overflow occurs, 0 otherwise
C Unaffected**Mode Bit** **OVM** operation is not affected by OVM bit value.**Cycles** 1

Example

NEGF *++AR3(2),R1

Before Instruction		After Instruction	
AR3	80 9800h	AR3	80 9802h
R1	05 7B40 0025h 6.28125006e + 01	R1	07 F380 000h -1.4050e + 02
Data at 80 9802h	70C 8000h 1.4050e + 02	Data at 80 9802h	70C 8000h 1.4050e + 02
LV	0	LV	0
UF	0	UF	0
N	0	N	0
Z	0	Z	0
V	0	V	0
C	0	C	0

Syntax **NEGF** *src2, dst1*
 || **STF** *src3, dst2*

Operands *src2*: indirect (disp = 0, 1, IR0, IR1)
 dst1: register (R0 – R7)
 src3: register (R0 – R7)
 dst2: indirect (disp = 0, 1, IR0, IR1)

Opcode

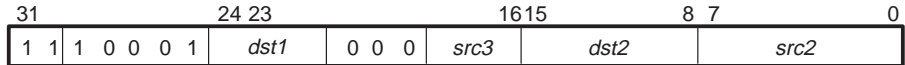

Word Fields None

Operation 0 – *src2* → *dst1*
 || *src3* → *dst2*

Description A floating-point negation and a floating-point store are performed in parallel. All registers are read at the beginning and loaded at the end of the execute cycle. This means that if one of the parallel operations (STF) reads from a register and the operation being performed in parallel (NEGF) writes to the same register, then STF accepts as input the contents of the register before it is modified by the NEGF.

If *src2* and *dst2* point to the same location, *src2* is read before the write to *dst2*.

Status Bits **LUF** 1 if a floating-point underflow occurs, 0 unchanged otherwise
 LV 1 if a floating-point overflow occurs, unchanged otherwise
 UF 1 if a floating-point underflow occurs, 0 otherwise
 N 1 if a negative result is generated, 0 otherwise
 Z 1 if a zero result is generated, 0 otherwise
 V 1 if a floating-point overflow occurs, 0 otherwise
 C Unaffected

Mode Bit **OVM** operation is not affected by OVM bit value.

Cycles 1

Example

```

    NEGF  *AR4--(1),R7
||   STF  R2,***AR5(1)

```

Before Instruction		After Instruction	
AR4	80 98E1h	AR4	80 98E0h
R7	0h	R7	05 84C0 0000h -6.281250e + 01
R2	07 33C0 0000h 1.79750e + 02	R2	07 33C0 0000h 1.79750e + 02
AR5	80 9803h	AR5	80 9804h
Data at 80 98E1h	57 B40 0000h 6.281250e + 01	Data at 80 98E1h	57 B40 0000h 6.281250e + 01
Data at 80 9804h	0h	Data at 80 9804h	733 C000h 1.79750e + 02
LUF	0	LUF	0
LV	0	LV	0
UF	0	UF	0
N	0	N	0
Z	0	Z	0
V	0	V	0
C	0	C	0

Syntax **NEGI** *src, dst*

Operands *src*: general-addressing modes (G)
 dst: register (any register in CPU primary-register file)

Opcode

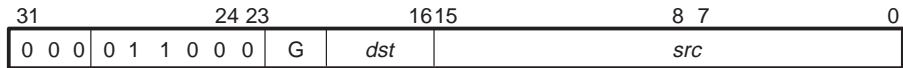

Word Fields

G	<i>src</i> addressing modes
00	register (any register in CPU primary-register file)
01	direct
10	indirect
11	immediate

Operation 0 – *src* → *dst*

Description The difference of the 0 and *src* operands is loaded into the *dst* register. The *dst* and *src* operands are assumed to be signed integers.

Status Bits If ST (SETCOND) = 0 and the destination register is R0 – R11, the condition flags are modified. If ST (SETCOND) = 1, they are modified for all destination registers.

- LUF** Unaffected
- LV** 1 if an integer overflow occurs, unchanged otherwise
- UF** 0
- N** 1 if a negative result is generated, 0 otherwise
- Z** 1 if a zero result is generated, 0 otherwise
- V** 1 if an integer overflow occurs, 0 otherwise
- C** 1 if a borrow occurs, 0 otherwise

Mode Bit **OVM** operation is affected by OVM bit value.

Cycles 1

Example

NEGI 174,R5 (174 = 0AEh)

Before Instruction			After Instruction		
R5	<input type="text" value="0DCh"/>	220	R5	<input type="text" value="0FFFFFF52"/>	-174
LUF	<input type="text" value="0"/>		LUF	<input type="text" value="0"/>	
LV	<input type="text" value="0"/>		LV	<input type="text" value="0"/>	
UF	<input type="text" value="0"/>		UF	<input type="text" value="0"/>	
N	<input type="text" value="0"/>		N	<input type="text" value="1"/>	
Z	<input type="text" value="0"/>		Z	<input type="text" value="0"/>	
V	<input type="text" value="0"/>		V	<input type="text" value="0"/>	
C	<input type="text" value="0"/>		C	<input type="text" value="1"/>	

Syntax **NEGI** *src2, dst1*
 || **STI** *src3, dst2*

Operands *src2*: indirect (disp = 0, 1, IR0, IR1)
 dst1: register (R0 – R7)
 src3: register (R0 – R7)
 dst2: indirect (disp = 0, 1, IR0, IR1)

Opcode

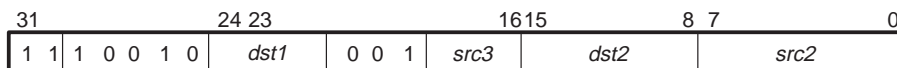

Word Fields None

Operation 0 – *src2* → *dst1*
 || *src3* → *dst2*

Description An integer negation and an integer store are performed in parallel. All registers are read at the beginning and loaded at the end of the execute cycle. This means that if one of the parallel operations (STI) reads from a register and the operation being performed in parallel (NEGI) writes to the same register, then STI accepts as input the contents of the register before it is modified by the NEGI.

If *src2* and *dst2* point to the same location, *src2* is read before the write to *dst2*.

Status Bits **LUF** Unaffected
 LV 1 if an integer overflow occurs, unchanged otherwise
 UF 0
 N 1 if a negative result is generated, 0 otherwise
 Z 1 if a zero result is generated, 0 otherwise
 V 1 if an integer overflow occurs, 0 otherwise
 C 1 if a borrow occurs, 0 otherwise

Mode Bit **OVM** operation is affected by OVM bit value.

Cycles 1

Example

```

NEGI  *-AR3,R2
|| STI  R2,*AR1++

```

Before Instruction		After Instruction	
AR3	80 982Fh	AR3	80 982Fh
R2	19h	R2	0FFFF FF24h
			-220
AR1	80 98A5h	AR1	80 98A6h
Data at 80 982Eh		Data at 80 982Eh	
	0DCh		0DCh
			220
Data at 80 98A5h		Data at 80 98A5h	
	0h		19h
			25
LUF	0	LUF	0
LV	0	LV	0
UF	0	UF	0
N	0	N	1
Z	0	Z	0
V	0	V	0
C	0	C	1

Syntax **NOP** *src*

Operands *src*: general-addressing modes (G)

Opcode

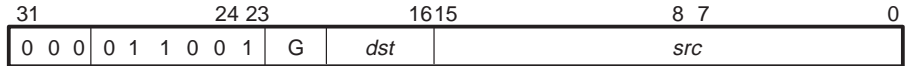

Word Fields

G	<i>src</i> addressing modes
00	register (no operation)
10	indirect (modify ARn, 0 ≤ n ≤ 7)

Operation No ALU or multiplier operations.
 ARn is modified if *src* is specified in indirect mode.

Description If the *src* operand is specified in the indirect mode, the specified addressing operation is performed, and a dummy memory read occurs. If the *src* operand is omitted, no operation is performed.

Status Bits **LUF** Unaffected
LV Unaffected
UF Unaffected
N Unaffected
Z Unaffected
V Unaffected
C Unaffected

Mode Bit **OVM** operation is not affected by OVM bit value.

Cycles 1

Example 1 NOP



Example 2 NOP *AR3-- (1)



Syntax **NORM** *src, dst*

Operands *src*: general-addressing modes (G)
 dst: register (R0 – R11)

Opcode

31	24 23	16 15	8 7	0
0 0 0	0 1 1 0 1 0	G	<i>dst</i>	<i>src</i>

Word Fields

G	<i>src</i> addressing modes
00	register (any register in CPU primary-register file)
01	direct
10	indirect
11	immediate

Operation norm (*src*) → *dst*

Description The *src* operand is assumed to be an unnormalized floating-point number; for example, the implied bit is set equal to the sign bit. The *dst* is set equal to the normalized *src* operand with the implied bit removed. The *dst* operand exponent is set to the *src* operand exponent minus the size of the left-shift necessary to normalize the *src*. The *dst* operand is assumed to be a normalized floating-point number.

For values of *src*:

- If *src* (exp) = −128 and *src* (man) = 0, then *dst* = 0, Z = 1, and UF = 0.
- If *src* (exp) = −128 and *src* (man) ≠ 0, then *dst* = 0, Z = 0, and UF = 1.
- For all other cases of the *src*, if a floating-point underflow occurs, then *dst* (man) is forced to 0 and *dst* (exp) = −128. If *src* (man) = 0, then *dst* (man) = 0 and *dst* (exp) = −128. Refer to Section 5.7 on page 5-27.

Status Bits

LUF 1 if a floating-point underflow occurs, unchanged otherwise
LV Unaffected
UF 1 if a floating-point underflow occurs, 0 otherwise
N 1 if a negative result is generated, 0 otherwise
Z 1 if a zero result is generated, 0 otherwise
V 0
C Unaffected

Mode Bit **OVM** operation is not affected by OVM bit value.

Cycles 1

Example

NORM R1, R2

Before Instruction

R1	<input type="text" value="04 0000 3AF5h"/>
R2	<input type="text" value="07 0C80 0000h"/>
LUF	<input type="text" value="0"/>
LV	<input type="text" value="0"/>
UF	<input type="text" value="0"/>
N	<input type="text" value="0"/>
Z	<input type="text" value="0"/>
V	<input type="text" value="0"/>
C	<input type="text" value="0"/>

After Instruction

R1	<input type="text" value="04 0000 3AF5h"/>
R2	<input type="text" value="F2 6BD4 0000h"/> 1.12451613e - 04
LUF	<input type="text" value="0"/>
LV	<input type="text" value="0"/>
UF	<input type="text" value="0"/>
N	<input type="text" value="0"/>
Z	<input type="text" value="0"/>
V	<input type="text" value="0"/>
C	<input type="text" value="0"/>

Syntax **NOT** *src*, *dst*

Operands *src*: general-addressing modes (G)
 dst: register (any register in CPU primary-register file)

Opcode

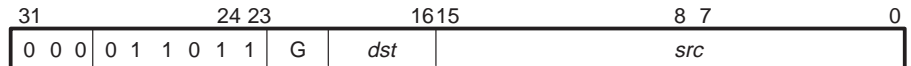

Word Fields

G	<i>src</i> addressing modes
00	register (any register in CPU primary-register file)
01	direct
10	indirect
11	immediate

Operation $\sim src \rightarrow dst$

Description The bitwise-logical complement of the *src* operand is loaded into the *dst* register. The complement is formed by a logical NOT of each bit of the *src* operand. The *dst* and *src* operands are assumed to be unsigned integers.

Status Bits If ST (SETCOND) = 0 and the destination register is R0 – R11, the condition flags are modified. If ST (SETCOND) = 1, they are modified for all destination registers.

LUF Unaffected
LV Unaffected
UF 0
N MSB of the output
Z 1 if a zero result is generated, 0 otherwise
V 0
C Unaffected

Mode Bit **OVM** operation is affected by OVM bit value.

Cycles 1

Example

NOT @982Ch, R4

	Before Instruction	After Instruction
DP	<input type="text" value="80h"/>	<input type="text" value="80h"/>
R4	<input type="text" value="0h"/>	<input type="text" value="0FFFF A1D0h"/>
Data at 80 982Ch	<input type="text" value="5E2Fh"/>	<input type="text" value="5E2Fh"/>
LUF	<input type="text" value="0"/>	<input type="text" value="0"/>
LV	<input type="text" value="0"/>	<input type="text" value="0"/>
UF	<input type="text" value="0"/>	<input type="text" value="0"/>
N	<input type="text" value="0"/>	<input type="text" value="1"/>
Z	<input type="text" value="0"/>	<input type="text" value="0"/>
V	<input type="text" value="0"/>	<input type="text" value="0"/>
C	<input type="text" value="0"/>	<input type="text" value="0"/>

Syntax **NOT** *src2, dst1*
 || **STI** *src3, dst2*

Operands *src2*: indirect (disp = 0, 1, IR0, IR1)
 dst1: register (R0 – R7)
 src3: register (R0 – R7)
 dst2: indirect (disp = 0, 1, IR0, IR1)

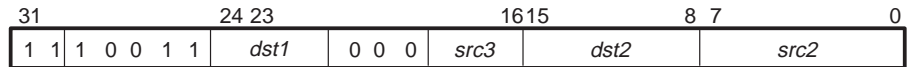
Opcode**Word Fields** None

Operation $\sim src2 \rightarrow dst1$
 || $src3 \rightarrow dst2$

Description A bitwise-logical NOT and an integer store are performed in parallel. All registers are read at the beginning and loaded at the end of the execute cycle. This means that if one of the parallel operations (STI) reads from a register and the operation being performed in parallel (NOT) writes to the same register, then STI accepts as input the contents of the register before it is modified by the NOT.

If *src2* and *dst2* point to the same location, *src2* is read before the write to *dst2*.

Status Bits **LUF** Unaffected
 LV Unaffected
 UF 0
 N MSB of the output
 Z 1 if a zero result is generated, 0 otherwise
 V 0
 C Unaffected

Mode Bit **OVM** operation is not affected by OVM bit value.**Cycles** 1

Example

```

NOT    *+AR2, R3
|| STI  R7, *-- AR4 (IR1)
    
```

Before Instruction		After Instruction	
AR2	80 99CBh	AR2	80 99CBh
R3	0h	R3	0FFFF F3D0h
R7	0DCh	R7	0DCh
AR4	80 9850h	AR4	80 9840h
IR1	10h	IR1	10h
Data at 80 99CCh	0C2Fh	Data at 80 99CCh	0C2Fh
Data at 80 9840h	0h	Data at 80 9840h	0DCh
LUF	0	LUF	0
LV	0	LV	0
UF	0	UF	1
N	0	N	0
Z	0	Z	0
V	0	V	0
C	0	C	0

220

220

220

Example

OR *++AR1(IR1),R2

Before Instruction		After Instruction	
AR1	80 9800h	AR1	80 9804h
IR1	4h	IR1	4h
R2	01256 0000h	R2	01256 2BCDh
Data at 80 9804h		Data at 80 9804h	
	2BCDh		2BCDh
LUF	0	LUF	0
LV	0	LV	0
UF	0	UF	0
N	0	N	0
Z	0	Z	0
V	0	V	0
C	0	C	0

Description	The bitwise-logical OR between the numbers at the <i>src1</i> and <i>src2</i> operands is loaded into the <i>dst</i> register. The numbers at the <i>src1</i> , <i>src2</i> , and <i>dst</i> operands are assumed to be unsigned integers. The <i>src2</i> immediate-addressing mode is sign extended.
Status Bits	If ST (SETCOND) = 0, the condition flags are modified if the destination register is R0 — R11. If ST (SETCOND) = 1, they are modified for all destination registers. LUF Unaffected LV Unaffected UF 0 N MSB of the output Z 1 if a zero result is generated, 0 otherwise V 0 C Unaffected
Mode Bit	OVM operation is not affected by OVM bit value.
Cycles	1
Example	None

Syntax **OR3** *src2, src1, dst1*
 || **STI** *src3, dst2*

Operands *src1*: register (R0 – R7)
 src2: indirect (disp = 0, 1, IR0, IR1)
 dst1: register (R0 – R7)
 src3: register (R0 – R7)
 dst2: indirect (disp = 0, 1, IR0, IR1)

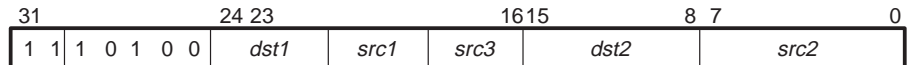
Opcode**Word Fields** None

Operation *src1* OR *src2* → *dst1*
 || *src3* → *dst2*

Description A bitwise-logical OR and an integer store are performed in parallel. All registers are read at the beginning and loaded at the end of the execute cycle. This means that if one of the parallel operations (STI) reads from a register and the operation being performed in parallel (OR3) writes to the same register, then STI accepts as input the contents of the register before it is modified by the OR3.

If *src2* and *dst2* point to the same location, *src2* is read before the write to *dst2*.

Status Bits **LUF** Unaffected
 LV Unaffected
 UF 0
 N MSB of the output
 Z 1 if a zero result is generated, 0 otherwise
 V 0
 C Unaffected

Mode Bit **OVM** operation is not affected by OVM bit value.**Cycles** 1

Example

```

OR3   *++AR2, R5, R2
|| STI R6, *AR1--
    
```

Before Instruction		After Instruction	
AR2	80 9830h	AR2	80 9831h
R5	80 0000h	R5	80 0000h
R2	0h	R2	80 9800h
R6	0DCh	R6	0DCh
AR1	80 9833h	AR1	80 9882h
Data at 80 9831h	9800h	Data at 80 9831h	9800h
Data at 80 9883h	0h	Data at 80 9883h	0DCh
LUF	0	LUF	0
LV	0	LV	0
UF	0	UF	0
N	0	N	0
Z	0	Z	0
V	0	V	0
C	0	C	0

220

220

220

Syntax **POP** *dst*

Operands *dst*: register (any register in CPU primary-register file)

Opcode

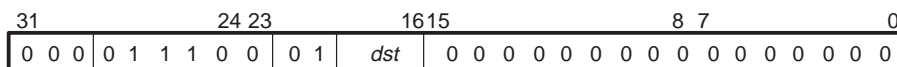

Word Fields None

Operation *SP-- → *dst*

Description The top of the current system stack is popped and loaded into the 32 LSBs of the *dst* register. The top of the stack is assumed to be a signed integer. The POP is performed with a post decrement of the stack pointer. The eight MSBs (exponent) of an extended-precision *dst* register (R11–R0) are left unmodified. If required they can be recovered with a POPF instruction.

Status Bits If ST (SETCOND) = 0 and the destination register is R0 – R11, the condition flags are modified. If ST (SETCOND) = 1, they are modified for all destination registers.

LUF Unaffected
LV Unaffected
UF 0
N 1 if a negative result is generated, 0 otherwise
Z 1 if a zero result is generated, 0 otherwise
V 0
C Unaffected

Mode Bit **OVM** operation is not affected by OVM bit value.

Cycles 1

Example POP R3

	Before Instruction		After Instruction
SP	80 9856h		80 9855h
R3	012DAh	4 826	0FFFF 0DA4h
Data at 80 9856h	0FFFF 0DA4h	–62 044	0FFFF 0DA4h
LUF	0		0
LV	0		0
UF	0		0
N	0		1
Z	0		0
V	0		0
C	0		0

Syntax **RCPF** *src, dst*

Operands *src*: extended-precision register-, direct- and indirect-addressing modes
dst: R0 – R11

Opcode

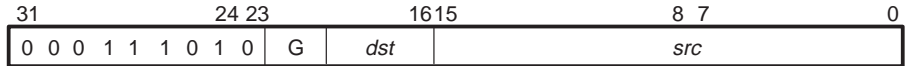

Word Fields

G	<i>src</i> addressing modes
00	register (any register in CPU primary-register file)
01	direct
10	indirect
11	immediate

Operation 16-bit reciprocal of *src* → *dst*

Description The 16-bit approximation of the reciprocal of the *src* operand is loaded into the *dst* register. The *dst* and *src* operands are assumed to be floating-point numbers.

Status Bits

LUF 1 if a floating-point underflow occurs, unchanged otherwise
LV 1 if a floating-point overflow occurs, unchanged otherwise
UF 1 if a floating-point underflow occurs, 0 otherwise
N 1 if a negative result is generated, 0 otherwise
Z 1 if a zero result, 0 otherwise
V 1 if a floating-point overflow occurs, 0 otherwise
C Unaffected

Mode Bit **OVM** operation is not affected by OVM bit value.

Cycles 1

Example None

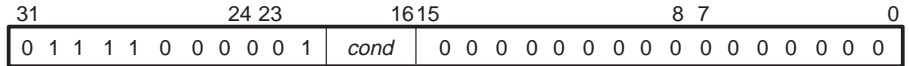
Syntax RETI*cond*D**Operands** None**Opcode****Word Fields** None

Operation If (*cond* is true)
 *(SP) → PC
 ST(PGIE) → ST(GIE)
 ST(PCF) → ST(CF)
 Else, continue

Description Performs a delayed return from an interrupt or trap.

Because this is a delayed return, the three instructions following the RETI*cond*D are fetched and executed. These three instructions should not modify the program flow, load the status register, or modify the stack pointer (SP) register. See Section 14.2 for a list of condition mnemonics, encoding, and flags.

Interrupts are disabled for the duration of the RETI*cond*D.

Status Bits

- LUF** Unaffected
- LV** Unaffected
- UF** Unaffected
- N** Unaffected
- Z** Unaffected
- V** Unaffected
- C** Unaffected

Mode Bit **OVM** operation is not affected by OVM bit value.**Cycles** 1**Example** None

Syntax **RETScond**

Operands None

Opcode

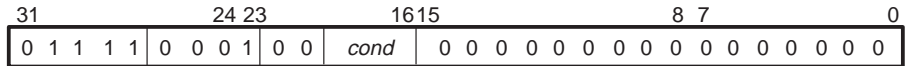

Word Fields None

Operation If *cond* is true:
 *SP-- → PC.
 Else, continue.

Description A conditional return is performed. If the condition is true, the top of the stack is popped to the PC.

The 'C4x provides 20 condition codes that can be used with this instruction (see Section 14.2 for a list of condition mnemonics, encoding, and flags).

Status Bits **LUF** Unaffected
 LV Unaffected
 UF Unaffected
 N Unaffected
 Z Unaffected
 V Unaffected
 C Unaffected

Mode Bit **OVM** operation is not affected by OVM bit value.

Cycles 4

Example RETSGE

	Before Instruction		After Instruction
PC	123h	PC	456h
SP	80 983Ch	SP	80 983Bh
Data at 80 983Ch	456h	Data at 80 983Ch	456h
LUF	0	LUF	0
LV	0	LV	0
UF	0	UF	0
N	0	N	0
Z	0	Z	0
V	0	V	0
C	0	C	0

Syntax **RND** *src, dst*

Operands *src*: general-addressing modes (G)
dst: register (R0 – R11)

Opcode

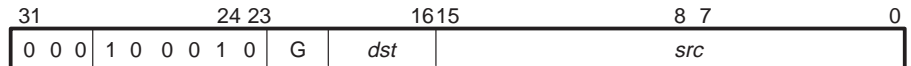

Word Fields

G	<i>src</i> addressing modes
00	register (any register in CPU primary-register file)
01	direct
10	indirect
11	immediate

Operation $\text{rnd}(\text{src}) \rightarrow \text{dst}$

Description The result of rounding the *src* operand is loaded into the *dst* register. The *src* operand is rounded to the nearest single-precision floating-point value. If the *src* operand is exactly halfway between two single-precision values, it is rounded to the most positive of those values. Notice that the rounding of 0 does not set the zero (z) status bit but the underflow bit.

Status Bits

LUF 1 if a floating-point underflow occurs, unchanged otherwise
LV 1 if a floating-point overflow occurs, unchanged otherwise
UF 1 if a floating-point underflow occurs or the *src* operand is zero, 0 otherwise
N 1 if a negative result is generated, 0 otherwise
Z Unaffected
V 1 if a floating-point overflow occurs, 0 otherwise
C Unaffected

Mode Bit **OVM** operation is affected by OVM bit value.

Cycles 1

Example

RND R5, R2

Before Instruction

R5	<input type="text" value="07 33C1 6EEFh"/>	1.79755599e + 02
R2	<input type="text" value="0h"/>	
LUF	<input type="text" value="0"/>	
LV	<input type="text" value="0"/>	
UF	<input type="text" value="0"/>	
N	<input type="text" value="0"/>	
Z	<input type="text" value="0"/>	
V	<input type="text" value="0"/>	
C	<input type="text" value="0"/>	

After Instruction

R5	<input type="text" value="07 33C1 6EEFh"/>	1.79755599e + 02
R2	<input type="text" value="07 33C1 6EEFh"/>	1.79755600e + 02
LUF	<input type="text" value="0"/>	
LV	<input type="text" value="0"/>	
UF	<input type="text" value="0"/>	
N	<input type="text" value="0"/>	
Z	<input type="text" value="0"/>	
V	<input type="text" value="0"/>	
C	<input type="text" value="0"/>	

Syntax **ROL** *dst*

Operands *dst*: register (any register in CPU primary-register file)

Opcode

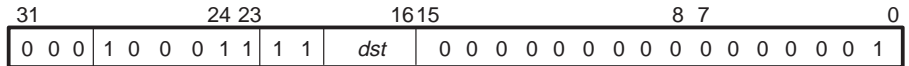

Word Fields None

Operation *dst* left-rotated 1 bit → *dst*

Description The contents of the *dst* operand are left-rotated one bit and loaded into the *dst* register. This is a circular rotate with the MSB transferred into the LSB.

Rotate left:

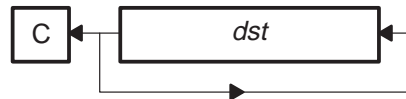

Status Bits If ST (SETCOND) = 0 and the destination register is R0 – R11, the condition flags are modified. If ST (SETCOND) = 1, they are modified for all destination registers.

- LUF** Unaffected
- LV** Unaffected
- UF** 0
- N** MSB of the output
- Z** 1 if a zero output is generated, 0 otherwise
- V** 0
- C** Set to the value of the bit rotated out of the high-order bit

Mode Bit **OVM** operation is not affected by OVM bit value.

Cycles 1

Example ROL R3

	Before Instruction	After Instruction
R3	8002 5CD4h	0004 B9A9h
LUF	0	0
LV	0	0
UF	0	0
N	0	0
Z	0	0
V	0	0
C	0	1

Syntax **ROLC** *dst*

Operands *dst*: register (any register in CPU primary-register file)

Opcode

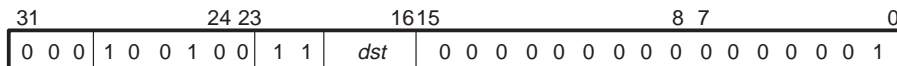

Word Fields None

Operation *dst* left-rotated 1 bit through carry bit → *dst*

Description The contents of the *dst* operand are left-rotated one bit through the carry bit and loaded into the *dst* register. The MSB is rotated to the carry bit, at the same time the carry bit is transferred to the LSB.

Rotate left through carry bit:



Status Bits If ST (SETCOND) = 0 and the destination register is R0 – R11, the condition flags are modified. If ST (SETCOND) = 1, they are modified for all destination registers.

- LUF** Unaffected
- LV** Unaffected
- UF** 0
- N** MSB of the output
- Z** 1 if a zero output is generated, 0 otherwise
- V** 0
- C** Set to the value of the bit rotated out of the high-order bit

Mode Bit **OVM** operation is not affected by OVM bit value.

Cycles 1

Example 1 ROLC R3

	Before Instruction	After Instruction
R3	0000 0420h	00000 0841h
LUF	0	0
LV	0	0
UF	0	0
N	0	0
Z	0	0
V	0	0
C	1	0

Example 2

ROLC R3

Before Instruction		After Instruction	
R3	8000 4281h	R3	0000 8502h
LUF	0	LUF	0
LV	0	LV	0
UF	0	UF	0
N	0	N	0
Z	0	Z	0
V	0	V	0
C	0	C	1

Syntax ROR *dst*

Operands *dst*: register (any register in CPU primary-register file)

Opcode

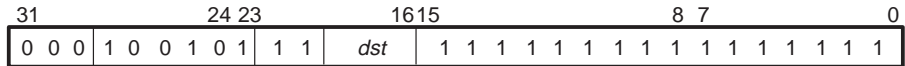

Word Fields None

Operation *dst* right-rotated 1 bit → *dst*

Description The contents of the *dst* operand are right-rotated one bit and loaded into the *dst* register. The LSB is rotated into the carry bit and also transferred into the MSB.

Rotate right:



Status Bits If ST (SETCOND) = 0 and the destination register is R0 – R11, the condition flags are modified. If ST (SETCOND) = 1, they are modified for all destination registers.

- LUF** Unaffected
- LV** Unaffected
- UF** 0
- N** MSB of the output
- Z** 1 if a zero output is generated, 0 otherwise
- V** 0
- C** Set to the value of the bit rotated out of the high-order bit

Mode Bit **OVM** operation is not affected by OVM bit value.

Cycles 1

Example ROR R7

	Before Instruction	After Instruction
R7	00000421h	80000210h
LUF	0	0
LV	0	0
UF	0	0
N	0	1
Z	0	0
V	0	0
C	0	1

Syntax **RPTB** *src*

Operands *src*: 24-bit signed immediate displacement or register mode

Opcode

For 24-bit signed immediate or register mode:

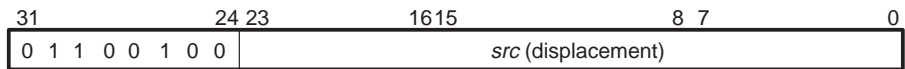

For register mode:

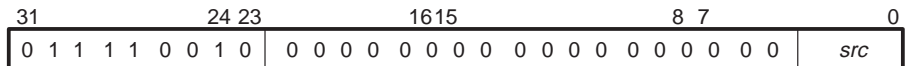

Word Fields None

Operation
src + PC +1 → RE
 1 → ST (RM)
 Next PC → RS

Description RPTB allows a block of instructions to be repeated a number of times without any penalty for looping.

It activates the block repeat mode of updating the PC. The *src* operand can be a 32-bit register value or a 24-bit signed immediate value (displacement). The resulting *src* address is the end address of the block to be repeated. This address is loaded into the repeat end address (RE) register. A 1 is written into the repeat mode bit of status register [ST(RM)] to indicate that the PC is to be updated in the repeat mode. The address of the next instruction is loaded into the repeat-start address (RS) register.

RE should be greater than or equal to RS (RE ≥ RS). Otherwise, the code does not repeat, even though the RM bit remains set to 1.

Status Bits

- LUF** Unaffected
- LV** Unaffected
- UF** Unaffected
- N** Unaffected
- Z** Unaffected
- V** Unaffected
- C** Unaffected

Mode Bit **OVM** operation is not affected by OVM bit value.

Cycles 4

Example None

Syntax	RPTBD <i>src</i>
Operands	<i>src</i> : 24-bit signed immediate displacement or register mode
Opcodes	

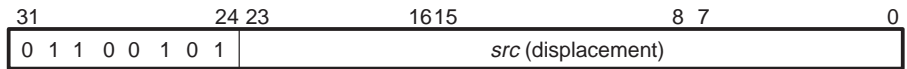
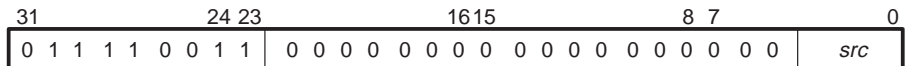
For 24-bit signed immediate or register mode:**For register mode:**

Word Fields	None
Operation	if <i>src</i> is an immediate value (displacement) $src + PC + 3 \rightarrow RE$ Else: $src \rightarrow RE$ $1 \rightarrow ST(RM)$ $PC \text{ of RPTBD} + 4 \rightarrow RS$

Description RPTBD allows a block of instructions to be repeated a number of times without any penalty for looping and with single-cycle execution of the RPTBD instruction. It activates the block repeat mode of updating the PC. The *src* operand can be a 32-bit register value or a 24-bit signed immediate value (displacement). The resulting *src* address is loaded into the repeat-end address (RE) register (block-end address). A 1 is written to the status-register repeat mode bit [ST(RM)], indicating the PC is to be updated in the repeat mode. The address of the next instruction +3 is loaded into the repeat-start address (RS) register.

RE should be greater than or equal to RS ($RE \geq RS$). Otherwise, the code will not repeat, even though the RM bit remains set to 1.

RPTBD does not flush the pipeline. The three instructions following RPTBD are executed and should not modify the program flow. These three instructions are not part of the block that is repeated. The RC register must be loaded before the RPTBD instruction executes. It should not be loaded in the three instructions after RPTBD.

Interrupts are disabled during the next three instructions after RPTBD.

Status Bits	LUF	Unaffected
	LV	Unaffected
	UF	Unaffected
	N	Unaffected
	Z	Unaffected
	V	Unaffected
	C	Unaffected
Mode Bit	OVM operation is not affected by OVM bit value.	
Cycles	1	
Example	None	

Example

RPTS AR5

	Before Instruction		After Instruction
PC	123h	PC	124h
ST	0h	ST	100h
RS	0h	RS	124h
RE	0h	RE	124h
RC	0h	RC	0FFh
AR5	0FFh	AR5	0FFh
LUF	0	LUF	0
LV	0	LV	0
UF	0	UF	0
N	0	N	0
Z	0	Z	0
V	0	V	0
C	0	C	0

The RPTS instruction is not interruptable. Interrupts are held pending until the RPTS instruction is finished executing. In timing-critical applications, this could cause timings to be inaccurate; thus, in timing-critical applications, use caution when using the RPTS instruction.

Syntax **SIGI** *src, dst*

Operands *src*: direct- and indirect-addressing modes (assumed to be signed integer)
dst: register mode (assumed to be signed integer)

Opcode

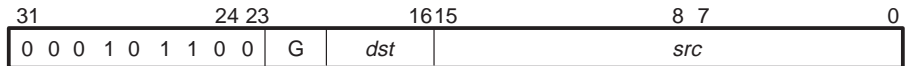

Word Fields

G	<i>src</i> addressing modes
01	direct
10	indirect

Operation $\overline{\text{LOCK}}$ (or $\overline{\text{LLOCK}}$) pin brought low
src → *dst*
 $\overline{\text{LOCK}}$ (or $\overline{\text{LLOCK}}$) pin brought high

Description An interlocking operation is signaled by the appropriate bus-lock signal ($\overline{\text{LOCK}}$ or $\overline{\text{LLOCK}}$) if, and only if, an external-memory access is performed. The *src* and *dst* operands are assumed to be signed integers. After the read is performed, the bus-lock signal is deasserted. If an internal-memory access is performed, SIGI performs the read but does not assert a bus-lock signal. Refer to Section 9.7 on page 9-39 for a detailed description.

The numbers at the *src* and *dst* operands are treated as signed integers.

Status Bits If ST (SETCOND) = 0 and the destination register is R0 – R11, the condition flags are modified. If ST (SETCOND) = 1, they are modified for all destination registers.

- LUF** Unaffected
- LV** Unaffected
- UF** 0
- N** 1 if a negative result is generated, 0 otherwise
- Z** 1 if a zero result is generated, 0 otherwise
- V** 0
- C** Unaffected

Mode Bit **OVM** operation is not affected by OVM bit value.

Cycles 1

Example None

Example

STF R2,@98A1h

Before Instruction	
DP	<input type="text" value="80h"/>
R2	<input type="text" value="052 C501 900h"/> 4.30782204e + 01
Data at 80 98A1h	<input type="text" value="0h"/>
LUF	<input type="text" value="0"/>
LV	<input type="text" value="0"/>
UF	<input type="text" value="0"/>
N	<input type="text" value="0"/>
Z	<input type="text" value="0"/>
V	<input type="text" value="0"/>
C	<input type="text" value="0"/>

After Instruction	
DP	<input type="text" value="80h"/>
R2	<input type="text" value="052 C501 900h"/> 4.30782204e + 01
Data at 80 98A1h	<input type="text" value="052 C5019h"/> 4.30782204e + 01
LUF	<input type="text" value="0"/>
LV	<input type="text" value="0"/>
UF	<input type="text" value="0"/>
N	<input type="text" value="0"/>
Z	<input type="text" value="0"/>
V	<input type="text" value="0"/>
C	<input type="text" value="0"/>

Syntax **STFI** *src, dst*

Operands *src*: register (R0 – R11)
dst: general-addressing modes (G)

Opcode

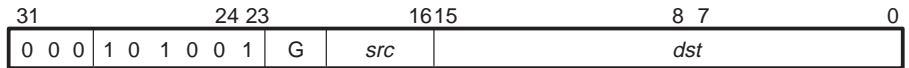

Word Fields

G	<i>src</i> addressing modes
01	direct
10	indirect

Operation *src* → *dst*
Signal end of interlocked operation.

Description The *src* register is loaded into the *dst* memory location. An interlocked operation is signaled over $\overline{\text{LOCK}}$ or $\overline{\text{LLOCK}}$. The *src* and *dst* operands are assumed to be floating-point numbers. Refer to Section 9.7 on page 9-39 for detailed information.

Status Bits **LUF** Unaffected
LV Unaffected
UF Unaffected
N Unaffected
Z Unaffected
V Unaffected
C Unaffected

Mode Bit **OVM** operation is not affected by OVM bit value.

Cycles 1

Example

STFI R3, *-AR4

Before Instruction		After Instruction			
R3	<input type="text" value="07 33C0 0000h"/>	1.79750e + 02	R3 <input type="text" value="07 33C0 0000h"/>	1.79750e + 02	
AR4	<input type="text" value="80 993Ch"/>		AR4 <input type="text" value="80 993Ch"/>		
Data at 80 993Bh	<input type="text" value="0h"/>		Data at 80 993Bh	<input type="text" value="733 C000h"/>	1.79750e + 02
LUF	<input type="text" value="0"/>		LUF	<input type="text" value="0"/>	
LV	<input type="text" value="0"/>		LV	<input type="text" value="0"/>	
UF	<input type="text" value="0"/>		UF	<input type="text" value="0"/>	
N	<input type="text" value="0"/>		N	<input type="text" value="0"/>	
Z	<input type="text" value="0"/>		Z	<input type="text" value="0"/>	
V	<input type="text" value="0"/>		V	<input type="text" value="0"/>	
C	<input type="text" value="0"/>		C	<input type="text" value="0"/>	

Syntax **STF** *src2*, *dst2*
 || **STF** *src1*, *dst1*

Operands *src1*: register (Rn1, 0 ≤ n1 ≤ 7)
 dst1: indirect (disp = 0, 1, IR0, IR1)
 src2: register (Rn2, 0 ≤ n2 ≤ 7)
 dst2: indirect (disp = 0, 1, IR0, IR1)

Opcode

31	24	23	16	15	8	7	0
1	1	0	0	0	0	0	0
		<i>src2</i>	0	0	0	<i>src1</i>	<i>dst1</i>
						<i>dst2</i>	

Word Fields None

Operation *src2* → *dst2*
 || *src1* → *dst1*

Description Two STF instructions are executed in parallel. Both *src1* and *src2* are assumed to be floating-point numbers.

Status Bits **LUF** Unaffected
 LV Unaffected
 UF Unaffected
 N Unaffected
 Z Unaffected
 V Unaffected
 C Unaffected

Mode Bit **OVM** operation is not affected by OVM bit value.

Cycles 1

Example **STF** R4, *AR3--
 || **STF** R3, *++AR5

Before Instruction		After Instruction			
R4	<input type="text" value="07 0C80 0000h"/>	1.4050e + 02	R4 <input type="text" value="07 0C80 0000h"/>	1.4050e + 02	
AR3	<input type="text" value="80 9835h"/>		AR3 <input type="text" value="80 9834h"/>		
R3	<input type="text" value="07 33C0 0000h"/>	1.79750e + 02	R3 <input type="text" value="07 33C0 0000h"/>	1.79750e + 02	
AR5	<input type="text" value="80 99D2h"/>		AR5 <input type="text" value="80 99D3h"/>		
Data at 80 9835h	<input type="text" value="0h"/>		Data at 80 9835h	<input type="text" value="070C 8000h"/>	1.4050e + 02
Data at 80 99D3h	<input type="text" value="0h"/>		Data at 80 99D3h	<input type="text" value="0733 C00000h"/>	1.79750e + 02
LUF	<input type="text" value="0"/>		LUF	<input type="text" value="0"/>	
LV	<input type="text" value="0"/>		LV	<input type="text" value="0"/>	
UF	<input type="text" value="0"/>		UF	<input type="text" value="0"/>	
N	<input type="text" value="0"/>		N	<input type="text" value="0"/>	
Z	<input type="text" value="0"/>		Z	<input type="text" value="0"/>	
V	<input type="text" value="0"/>		V	<input type="text" value="0"/>	
C	<input type="text" value="0"/>		C	<input type="text" value="0"/>	

Syntax **STII** *src, dst*

Operands *src*: register (any register in CPU primary-register file)
 dst: general-addressing modes (G)

Opcode

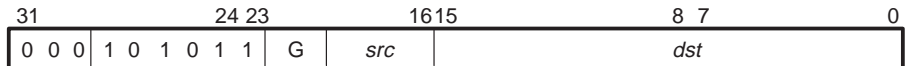

Word Fields

G	<i>src</i> addressing modes
01	direct
10	indirect

Operation *src* → *dst*
 Signal end of interlocked operation.

Description The *src* register is loaded into the *dst* memory location. An interlocked operation is signaled over $\overline{\text{LOCK}}$ or $\overline{\text{LLOCK}}$. The *src* and *dst* operands are assumed to be signed integers. Refer to Section 9.7 on page 9-39 for detailed information.

Status Bits **LUF** Unaffected
 LV Unaffected
 UF Unaffected
 N Unaffected
 Z Unaffected
 V Unaffected
 C Unaffected

Mode Bit OVM operation is not affected by OVM bit value.

Cycles 1

Example STII R1, @98AEh

	Before Instruction	After Instruction
DP	80h	80h
R1	78Dh	78Dh
Data at 80 98AEh	25Ch	78Dh

Example

```

    STI    R0, *++AR2( IR0 )
|| STI    R5, *AR0

```

Before Instruction		After Instruction			
R0	0DCh	220	R0	0DCh	220
AR2	80 9830h		AR2	80 9838h	
IR0	8h		IR0	8h	
R5	35h	53	R5	35h	53
AR0	80 98D3h		AR0	80 98D3h	
Data at 80 9838h	0h		Data at 80 9838h	0DCh	220
Data at 80 98D3h	0h		Data at 80 98D3h	35h	53
LUF	0		LUF	0	
LV	0		LV	0	
UF	0		UF	0	
N	0		N	0	
Z	0		Z	0	
V	0		V	0	
C	0		C	0	

Syntax **STIK** *src*, *dst*

Operands *src*; 5-bit signed integer
dst: direct and indirect mode

Opcode

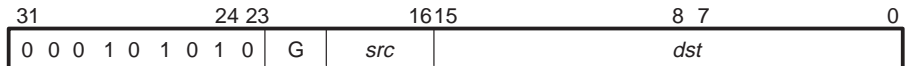

Word Fields

G	<i>src</i> addressing modes
00	direct
11	indirect

Operation *src* → *dst*

Description The 5-bit signed integer *src* value is loaded into the *dst* memory location. The *src* and *dst* operands are assumed to be signed integers.

Status Bits

LUF Unaffected
LV Unaffected
UF Unaffected
N Unaffected
Z Unaffected
V Unaffected
C Unaffected

Mode Bit OVM operation is not affected by OVM bit value.

Cycles 1

Example None

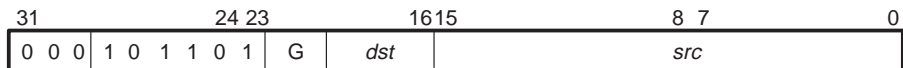
Syntax **SUBB** *src, dst***Operands** *src*: general-addressing modes (G)
dst: register (any register in CPU primary-register file)**Opcode****Word Fields**

G	<i>src</i> addressing modes
00	register (any register in CPU primary-register file)
01	direct
10	indirect
11	immediate

Operation $dst - src - C \rightarrow dst$ **Description** The difference of the *dst*, *src*, and C operands, as calculated above, is loaded into the *dst* register. The *dst* and *src* operands are assumed to be signed integers.**Status Bits** If ST (SETCOND) = 0 and the destination register is R0 – R11, the condition flags are modified. If ST (SETCOND) = 1, they are modified for all destination registers.

LUF Unaffected
LV 1 if an integer overflow occurs, unchanged otherwise
UF 0
N 1 if a negative result is generated, 0 otherwise
Z 1 if a zero result is generated, 0 otherwise
V 1 if an integer overflow occurs, 0 otherwise
C 1 if a borrow occurs, 0 otherwise

Mode Bit OVM operation is affected by OVM bit value.**Cycles** 1

Example

SUBB *AR5++(4),R5

Before Instruction		After Instruction	
AR5	80 9800h	AR5	80 9804h
R5	0FAh	R5	032h
	250		50
Data at 80 9800h		Data at 80 9800h	
	0C7h		0C7h
	199		100
LUF	0	LUF	0
LV	0	LV	0
UF	0	UF	0
N	0	N	0
Z	0	Z	0
V	0	V	0
C	1	C	0

Syntax **SUBB3** *src2, src1, dst*

Operands *src1, src2*: type 1 or type 2 three-operand addressing modes
dst: register mode (any register in CPU primary-register file)

Opcode

Type 1

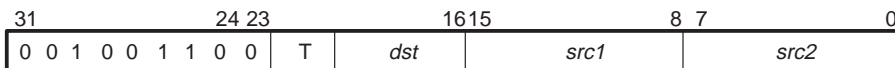

Type 2

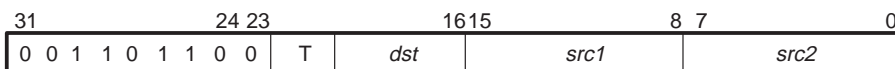

Word Fields

Type 1

	T <i>src1</i> addressing modes	<i>src2</i> addressing modes
00	register mode (any CPU register)	register mode (any CPU register)
01	indirect mode (disp = 0, 1, IR0, IR1)	register mode (any CPU register)
10	register mode (any CPU register)	indirect mode (disp = 0, 1, IR0, IR1)
11	indirect mode (disp = 0, 1, IR0, IR1)	indirect mode (disp = 0, 1, IR0, IR1)

Type 2

	T <i>src1</i> addressing modes	<i>src2</i> addressing modes
00	register mode (any CPU register)	8-bit signed immediate
01	register mode (any CPU register)	indirect mode *+ARn(5-bit unsigned displacement)
10	indirect mode *+ARn(5-bit unsigned displacement)	8-bit signed immediate
11	indirect mode *+ARn1(5-bit unsigned displacement)	indirect mode *+ARn2(5-bit unsigned displacement)

Operation

$$src1 - src2 - C \rightarrow dst$$

Description	The difference of the <i>src1</i> and <i>src2</i> operands and the C (carry) flag is loaded into the <i>dst</i> register. The <i>src1</i> , <i>src2</i> , and <i>dst</i> operands are assumed to be signed integers.
Status Bits	If ST (SETCOND) = 0 and the destination register is R0 – R11, the condition flags are modified. If ST (SETCOND) = 1, they are modified for all destination registers. LUF Unaffected LV 1 if an integer overflow occurs, unchanged otherwise UF 0 N 1 if a negative result is generated, 0 otherwise Z 1 if a zero result is generated, 0 otherwise V 1 if an integer overflow occurs, 0 otherwise C 1 if a borrow is generated, 0 otherwise
Mode Bit	OVM operation is affected by OVM bit value.
Cycles	1
Example	None

Syntax **SUBC** *src, dst*

Operands *src*: general-addressing modes (G)
 dst: register (any register in CPU primary-register file)

Opcode

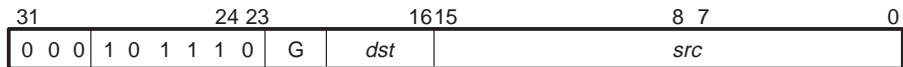

Word Fields

G	<i>src</i> addressing modes
00	register (any register in CPU primary-register file)
01	direct
10	indirect
11	immediate

Operation If $(dst - src \geq 0)$:
 $(dst - src \ll 1) \text{ OR } 1 \rightarrow dst$
 Else:
 $dst \ll 1 \rightarrow dst$

Description The *src* operand is subtracted from the *dst* operand. The *dst* operand is loaded with a value that depends upon the result of the subtraction. If $(dst - src)$ is greater than or equal to zero, then $(dst - src)$ is left-shifted one bit, the least-significant bit is set to 1, and the result is loaded into the *dst* register. If $(dst - src)$ is less than zero, *dst* is left-shifted one bit and loaded into the *dst* register. The *dst* and *src* operands are assumed to be unsigned integers.

SUBC can be used to perform a single step of a multibit-integer division.

Status Bits **LUF** Unaffected
 LV Unaffected
 UF Unaffected
 N Unaffected
 Z Unaffected
 V Unaffected
 C Unaffected

Mode Bit OVM operation is not affected by OVM bit value.

Cycles 1

Example 1

SUBC @98C5h,R1

Before Instruction		After Instruction	
DP	80h	DP	80h
R1	04F6h	R1	0C9h
	1270		201
Data at 80 98C5h		Data at 80 98C5h	
	492h		1170
LUF	0	LUF	0
LV	0	LV	0
UF	0	UF	0
N	0	N	0
Z	0	Z	0
V	0	V	0
C	0	C	0

Example 2

SUBC 3000,R0 (3000 = 0BB8h)

Before Instruction		After Instruction	
R0	07D0h	R0	0FA0h
	2000		4000
LUF	0	LUF	0
LV	0	LV	0
UF	0	UF	0
N	0	N	0
Z	0	Z	0
V	0	V	0
C	0	C	0

Syntax **SUBF** *src*, *dst*

Operands *src*: general-addressing modes (G)
 dst: register (R0 – R11)

Opcode

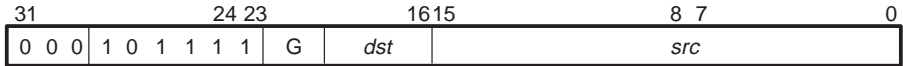

Word Fields

G	<i>src</i> addressing modes
00	register (R0-R11)
01	direct
10	indirect
11	immediate

Operation $dst - src \rightarrow dst$

Description The result of *the dst* operand minus the *src* operand is loaded into the *dst* register. The *dst* and *src* operands are assumed to be floating-point numbers.

Status Bits **LUF** 1 if a floating-point underflow occurs, unchanged otherwise
 LV 1 if an floating-point overflow occurs, unchanged otherwise
 UF 1 if a floating-point underflow occurs, 0 otherwise
 N 1 if a negative result is generated, 0 otherwise
 Z 1 if a zero result is generated, 0 otherwise
 V 1 if an floating-point overflow occurs, 0 otherwise
 C Unaffected

Mode Bit OVM operation is not affected by OVM bit value.

Cycles 1

Example

SUBF *AR0--(IR0),R5

Before Instruction		After Instruction	
AR0	80 9888h	AR0	80 9808h
IR0	80h	IR0	80h
R5	07 33C0 0000h 1.79750000e + 02	R5	05 1D00 0000h 3.9250e + 01
Data at 80 9888h	70C 8000h 1.4050e + 02	Data at 80 9888h	70C 8000h 1.4050e + 02
LUF	0	LUF	0
LV	0	LV	0
UF	0	UF	0
N	0	N	0
Z	0	Z	0
V	0	V	0
C	0	C	0

Syntax **SUBF3** *src2, src1, dst*

Operands *src1, src2*: type 1 or type 2 three-operand addressing modes
dst: register mode (R0 – R11)

Opcode

Type 1

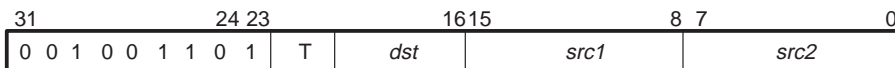

Type 2

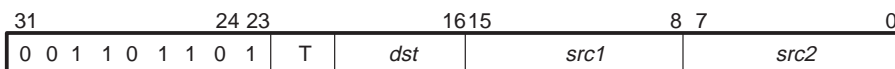

Word Fields

Type 1

T	<i>src1</i> addressing modes	<i>src2</i> addressing modes
00	register mode (R0–R11)	register mode (R0–R11)
01	indirect mode (disp = 0, 1, IR0, IR1)	register mode (R0–R11)
10	register mode (R0–R11)	indirect mode (disp = 0, 1, IR0, IR1)
11	indirect mode (disp = 0, 1, IR0, IR1)	indirect mode (disp = 0, 1, IR0, IR1)

Type 2

T	<i>src1</i> addressing modes	<i>src2</i> addressing modes
01	register mode (any CPU register)	indirect mode *+ARn(5-bit unsigned displacement)
11	indirect mode *+ARn1(5-bit unsigned displacement)	indirect mode *+ARn2(5-bit unsigned displacement)

Operation *src1* – *src2* → *dst*

Description	The difference of the <i>src1</i> and <i>src2</i> operands is loaded into the <i>dst</i> register. The <i>src1</i> , <i>src2</i> , and <i>dst</i> operands are assumed to be floating-point numbers.
Status Bits	LUF 1 if a floating-point underflow occurs, unchanged otherwise LV 1 if an floating-point overflow occurs, unchanged otherwise UF 1 if a floating-point underflow occurs, 0 otherwise N 1 if a negative result is generated, 0 otherwise Z 1 if a zero result is generated, 0 otherwise V 1 if an floating-point overflow occurs, 0 otherwise C Unaffected
Mode Bit	OVM operation is not affected by OVM bit value.
Cycles	1
Example	None

Example

```

SUBF3 R1, *-AR4(IR1),R0
|| STF  R7, *+AR5(IR0)

```

Before Instruction		After Instruction	
R1	05 7B40 0000h 6.28125e + 01	R1	05 7B40 0000h 6.28125e + 01
AR4	80 98B8h	AR4	80 98B8h
IR1	8h	IR1	8h
R0	0h	R0	06 1B60 0000h 7.768750e + 01
R7	07 33C0 0000h 1.79750e + 02	R7	07 33C0 0000h 1.79750e + 02
AR5	80 9850h	AR5	80 9850h
IR0	10h	IR0	10h
Data at 80 98B0h	70C 8000h 1.4050e + 02	Data at 80 98B0h	70C 8000h 1.4050e + 02
Data at 80 9860h	0h	Data at 80 9860h	733 C000h 1.79750e + 02
LUF	0	LUF	0
LV	0	LV	0
UF	0	UF	0
N	0	N	0
Z	0	Z	0
V	0	V	0
C	0	C	0

Syntax **SUBI** *src, dst*

Operands *src*: general-addressing modes (G)
 dst: register (any register in CPU primary-register file)

Opcode

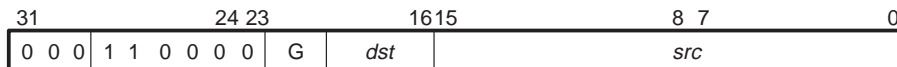

Word Fields

G	<i>src</i> addressing modes
00	register (any register in CPU primary-register file)
01	direct
10	indirect
11	immediate

Operation $dst - src \rightarrow dst$

Description The result of the *dst* operand minus the *src* operand is loaded into the *dst* register. The *dst* and *src* operands are assumed to be signed integers.

Status Bits If ST (SETCOND) = 0 and the destination register is R0 – R11, the condition flags are modified. If ST (SETCOND) = 1, they are modified for all destination registers.

- LUF** Unaffected
- LV** 1 if an integer overflow occurs, unchanged otherwise
- UF** 0
- N** 1 if a negative result is generated, 0 otherwise
- Z** 1 if a zero result is generated, 0 otherwise
- V** 1 if an integer overflow occurs, 0 otherwise
- C** 1 if a borrow occurs, 0 otherwise

Mode Bit OVM operation is affected by OVM bit value.

Cycles 1

Example

SUBI 220,R7

Before Instruction		After Instruction		
R7	<input type="text" value="226h"/>	550	R7 <input type="text" value="14Ah"/>	330
LUF	<input type="text" value="0"/>		LUF	<input type="text" value="0"/>
LV	<input type="text" value="0"/>		LV	<input type="text" value="0"/>
UF	<input type="text" value="0"/>		UF	<input type="text" value="0"/>
N	<input type="text" value="0"/>		N	<input type="text" value="0"/>
Z	<input type="text" value="0"/>		Z	<input type="text" value="0"/>
V	<input type="text" value="0"/>		V	<input type="text" value="0"/>
C	<input type="text" value="0"/>		C	<input type="text" value="0"/>

Syntax

SUBI3 *src2, src1, dst*

Operands

src1, src2: type 1 or type 2 three-operand addressing modes

dst: register mode (any register in CPU primary-register file)

Opcod

Type 1

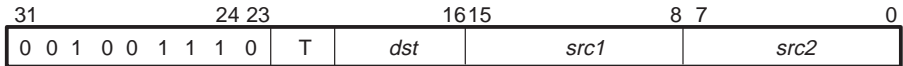

Type 2

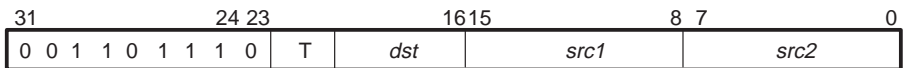

Word Fields

Type 1

	T <i>src1</i> addressing modes	<i>src2</i> addressing modes
00	register mode (any CPU register)	register mode (any CPU register)
01	indirect mode (disp = 0, 1, IR0, IR1)	register mode (any CPU register)
10	register mode (any CPU register)	indirect mode (disp = 0, 1, IR0, IR1)
11	indirect mode (disp = 0, 1, IR0, IR1)	indirect mode (disp = 0, 1, IR0, IR1)

Type 2

	T <i>src1</i> addressing modes	<i>src2</i> addressing modes
00	register mode (any CPU register)	8-bit signed immediate
01	register mode (any CPU register)	indirect mode <i>*+ARn</i> (5-bit unsigned displacement)
10	indirect mode <i>*+ARn</i> (5-bit unsigned displacement)	8-bit signed immediate
11	indirect mode <i>*+ARn1</i> (5-bit unsigned displacement)	indirect mode <i>*+ARn2</i> (5-bit unsigned displacement)

Operation

src1 – *src2* → *dst*

Description	The result of the <i>src1</i> operand minus the <i>src2</i> operand is loaded into the <i>dst</i> register. The <i>src1</i> , <i>src2</i> , and <i>dst</i> operands are assumed to be signed integers.
Status Bits	If ST (SETCOND) = 0 and the destination register is R0 – R11, the condition flags are modified. If ST (SETCOND) = 1, they are modified for all destination registers. LUF Unaffected LV 1 if an integer overflow occurs, unchanged otherwise UF 0 N 1 if a negative result is generated, 0 otherwise Z 1 if a zero result is generated, 0 otherwise V 1 if an integer overflow occurs, 0 otherwise C 1 if a borrow is generated, 0 otherwise
Mode Bit	OVM operation is affected by OVM bit value.
Cycles	1
Example	None

Syntax **SUBI3** *src1, src2, dst1*
 || **STI** *src3, dst2*

Operands *src1*: register (R0 – R7)
 src2: indirect (disp = 0, 1, IR0, IR1)
 dst1: register (R0 – R7)
 src3: register (R0 – R7)
 dst2: indirect (disp = 0, 1, IR0, IR1)

Opcode

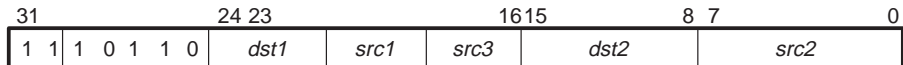

Word Fields None

Operation *src2* – *src1* → *dst1*
 || *src3* → *dst2*

Description An integer subtraction and an integer store are performed in parallel. All registers are read at the beginning and loaded at the end of the execute cycle. This means that if one of the parallel operations (STI) reads from a register and the operation being performed in parallel (SUBI3) writes to the same register, then STI accepts as input the contents of the register before it is modified by the SUBI3.

If *src3* and *dst1* point to the same location, *src3* is read before the write to *dst1*.

Status Bits **LUF** Unaffected
 LV 1 if an integer overflow occurs, unchanged otherwise
 UF 0
 N 1 if a negative result is generated, 0 otherwise
 Z 1 if a zero result is generated, 0 otherwise
 V 1 if an integer overflow occurs, 0 otherwise
 C 1 if a borrow occurs, 0 otherwise

Mode Bit OVM operation is affected by OVM bit value.

Cycles 1

Example

```

SUBI3 R7, *+AR2( IR0 ), R1
|| STI  R3, *++AR7

```

Before Instruction		After Instruction			
R7	14h	20	R7	14h	20
AR2	80 982Fh		AR2	80 982Fh	
IR0	10h		IR0	10h	
R1	0h		R1	0C8h	200
R3	35h	53	R3	35h	53
AR7	80 983Bh		AR7	80 983Ch	
Data at 80 983Fh	0DCh	220	Data at 80 983Fh	0DCh	220
Data at 80 983Ch	0h		Data at 80 983Ch	35h	53
LUF	0		LUF	0	
LV	0		LV	0	
UF	0		UF	0	
N	0		N	0	
Z	0		Z	0	
V	0		V	0	
C	0		C	0	

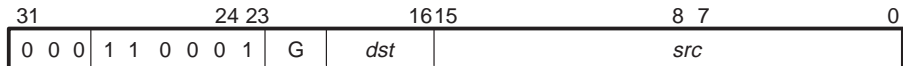
Syntax **SUBRB** *src, dst***Operands** *src*: general-addressing modes (G)
dst: register (any register in CPU primary-register file)**Opcode****Word Fields**

G	<i>src</i> addressing modes
00	register (any register in CPU primary-register file)
01	direct
10	indirect
11	immediate

Operation $src - dst - C \rightarrow dst$ **Description** The difference of the *src*, *dst*, and C operands, as calculated above, is loaded into the *dst* register. The *dst* and *src* operands are assumed to be signed integers.**Status Bits** If ST (SETCOND) = 0 and the destination register is R0 – R11, the condition flags are modified. If ST (SETCOND) = 1, they are modified for all destination registers.

- LUF** Unaffected
- LV** 1 if an integer overflow occurs, unchanged otherwise
- UF** 0
- N** 1 if a negative result is generated, 0 otherwise
- Z** 1 if a zero result is generated, 0 otherwise
- V** 1 if an integer overflow occurs, 0 otherwise
- C** 1 if a borrow occurs, 0 otherwise

Mode Bit OVM operation is affected by OVM bit value.**Cycles** 1

Example

SUBRB R4,R6

Before Instruction			After Instruction		
R4	<input type="text" value="03CBh"/>	971	R4	<input type="text" value="03CBh"/>	971
R6	<input type="text" value="0258h"/>	600	R6	<input type="text" value="0172h"/>	370
LUF	<input type="text" value="0"/>		LUF	<input type="text" value="0"/>	
LV	<input type="text" value="0"/>		LV	<input type="text" value="0"/>	
UF	<input type="text" value="0"/>		UF	<input type="text" value="0"/>	
N	<input type="text" value="0"/>		N	<input type="text" value="0"/>	
Z	<input type="text" value="0"/>		Z	<input type="text" value="0"/>	
V	<input type="text" value="0"/>		V	<input type="text" value="0"/>	
C	<input type="text" value="1"/>		C	<input type="text" value="0"/>	

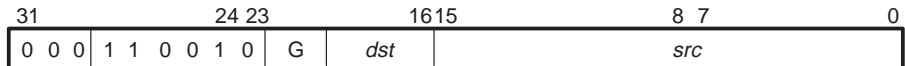
Syntax **SUBRF** *src, dst***Operands** *src*: general-addressing modes (G)
dst: register (R0 – R11)**Opcode****Word Fields**

G	<i>src</i> addressing modes
00	register (R0-R11)
01	direct
10	indirect
11	immediate

Operation *src* – *dst* → *dst***Description** The result of the *src* operand minus the *dst* operand is loaded into the *dst* register. The *dst* and *src* operands are assumed to be floating-point numbers.**Status Bits** **LUF** 1 if a floating-point underflow occurs, unchanged otherwise
LV 1 if a floating-point overflow occurs, unchanged otherwise
UF 1 if a floating-point underflow occurs, 0 otherwise
N 1 if a negative result is generated, 0 otherwise
Z 1 if a zero result is generated, 0 otherwise
V 1 if a floating-point overflow occurs, 0 otherwise
C Unaffected**Mode Bit** OVM operation is not affected by OVM bit value.**Cycles** 1

Example

SUBRF @9905h,R5

Before Instruction		After Instruction	
DP	80h	DP	80h
R5	05 7B40 0000h 6.281250e + 01	R5	06 69E0 0000h 1.16937500e + 02
Data at 80 9905h	733 C000h 1.79750e + 02	Data at 80 9905h	733 C000h 1.79750e + 02
LUF	0	LUF	0
LV	0	LV	0
UF	0	UF	0
N	0	N	0
Z	0	Z	0
V	0	V	0
C	0	C	0

Syntax **SUBRI** *src, dst*

Operands *src*: general-addressing modes (G)
dst: register (any register in CPU primary-register file)

Opcode

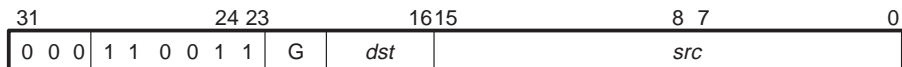

Word Fields

G	<i>src</i> addressing modes
00	register (any register in CPU primary-register file)
01	direct
10	indirect
11	immediate

Operation *src* – *dst* → *dst*

Description The result of the *src* operand minus the *dst* operand is loaded into the *dst* register. The *dst* and *src* operands are assumed to be signed integers.

Status Bits If ST (SETCOND) = 0 and the destination register is R0 – R11, the condition flags are modified. If ST (SETCOND) = 1, they are modified for all destination registers.

- LUF** Unaffected
- LV** 1 if an integer overflow occurs, unchanged otherwise
- UF** 0
- N** 1 if a negative result is generated, 0 otherwise
- Z** 1 if a zero result is generated, 0 otherwise
- V** 1 if an integer overflow occurs, 0 otherwise
- C** 1 if a borrow occurs, 0 otherwise

Mode Bit OVM operation is affected by OVM bit value.

Cycles 1

Example

SUBRI *AR5++(IR0),R3

Before Instruction		After Instruction	
AR5	80 9900h	AR5	80 9908h
IR0	8h	IR0	8h
R3	0DCh	R3	014Ah
	220		330
Data at 80 9900h		Data at 80 9900h	
	226h		226h
	550		550
LUF	0	LUF	0
LV	0	LV	0
UF	0	UF	0
N	0	N	0
Z	0	Z	0
V	0	V	0
C	0	C	0

Syntax **SWI**

Operands None

Opcode

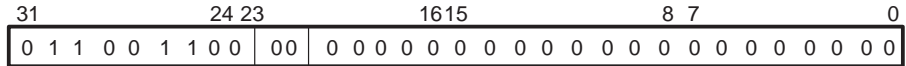

Word Fields None

Operation Performs an emulation interrupt

Description The SWI instruction performs an emulator interrupt. This is a reserved instruction and should not be used in normal programming.

Status Bits **LUF** Unaffected
LV Unaffected
UF Unaffected
N Unaffected
Z Unaffected
V Unaffected
C Unaffected

Mode Bit OVM operation is not affected by OVM bit value.

Cycles 4

Example None

Syntax **TOIEEE** *src, dst*

Operands *src*: extended-precision register (R0 – R11),
direct- and indirect-addressing modes
dst: extended-precision register

Opcode

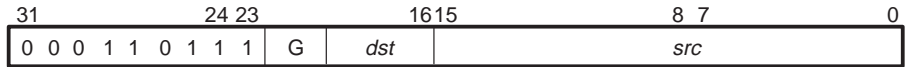

Word Fields

G	<i>src</i> addressing modes
00	register [extended-precision register (R0-R11)]
01	direct
10	indirect
11	immediate

Operation convert *src* to IEEE format → *dst*

Description The *src* operand is converted from a 2s-complement floating-point format to the IEEE floating-point format.

The *src* operand is assumed to be a single-precision floating-point number, except for the immediate mode that is considered a short 16-bit floating point format. The converted result goes into the 32 MSBs of the *dst* register. STF can be used to store the result to memory.

Status Bits

LUF Unaffected
LV 1 if an overflow occurs, unchanged otherwise
UF 0
N 1 if a negative result is generated, 0 otherwise
Z 1 if a zero result is generated, 0 otherwise
V 1 if an overflow occurs, 0 otherwise
C Unaffected

Mode Bit OVM operation is not affected by OVM bit value.

Cycles 1

Example None

Syntax **TOIEEE** *src2, dst1*
 || **STF** *src3, dst2*

Operands *src2*: indirect mode (disp = 0, 1, IR0, IR1)
 dst1: register mode (Rn1, 0 ≤ n1 ≤ 7)
 src3: register mode (Rn1, 0 ≤ n1 ≤ 7)
 dst2: indirect mode (disp = 0, 1, IR0, IR1)

Opcode

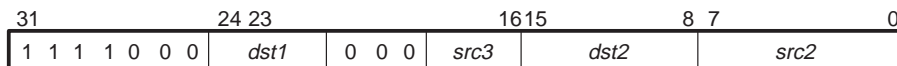

Word Fields None

Operation convert *src2* to IEEE format → *dst1*
 in parallel with
src3 → *dst2*

Description The *src2* operand is converted from a 2s-complement floating-point format to the IEEE floating-point format.

The *src2* operand is assumed to be a single-precision floating-point number. The converted result goes into the 32 MSBs of the *dst1* register. A floating-point store is done in parallel.

If *src2* and *dst2* point to the same location, then *src2* is read before the write to *dst2*.

Status Bits **LUF** Unaffected
 LV 1 if an overflow occurs, unchanged otherwise
 UF 0
 N 1 if a negative result is generated, 0 otherwise
 Z 1 if a zero result is generated, 0 otherwise
 V 1 if an overflow occurs, 0 otherwise
 C Unaffected

Mode Bit OVM operation is not affected by OVM bit value.

Cycles 1

Example None

Syntax **TRAPcond** N

Operands N: immediate mode ($0 \leq N \leq 511$)

Opcode

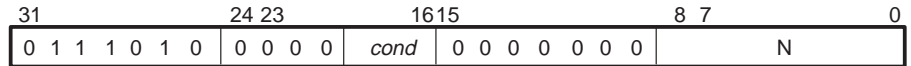

Word Fields None

Operation If (*cond* is true)

ST(GIE) → ST(PGIE)
 ST(CF) → ST(PCF)
 0 → ST(GIE)
 1 → ST(CF)
 next PC → *(++SP)
 trap vector N → PC

Else, continue.

Description If the condition is true, then GIE and CF are saved in PGIE and PCF in the status register, all interrupts are disabled (0 → GIE), and the cache is frozen (1 → CF). Then, the contents of the PC are pushed onto the system stack, and the PC is loaded with the contents of the specified trap vector (N). If the condition is not true, then continue normal operation.

If traps are to be nested, you may need to save the status register before executing *TRAPcond*.

Status Bits

GIE Set to 0 if TRAP executes
LUF Unaffected
LV Unaffected
UF Unaffected
N Unaffected
Z Unaffected
V Unaffected
C Unaffected

Mode Bit OVM operation is not affected by OVM bit value.

Cycles 5

Example None

Syntax **TSTB** *src, dst*

Operands *src*: general-addressing modes (G)
dst: register (any register in CPU primary-register file)

Opcode

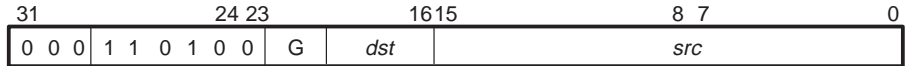

Word Fields

G	<i>src</i> addressing modes
00	register (any register in CPU primary-register file)
01	direct
10	indirect
11	immediate

Operation *dst* AND *src*

Description The bitwise-logical AND of the *dst* and *src* operands is formed, but the result is not loaded in any register. This allows for nondestructive compares. The *dst* and *src* operands are assumed to be unsigned integers.

Status Bits These condition flags are modified for all destination registers.

- LUF** Unaffected
- LV** Unaffected
- UF** 0
- N** MSB of the output
- Z** 1 if a zero output is generated, 0 otherwise
- V** 0
- C** Unaffected

Mode Bit OVM operation is not affected by OVM bit value.

Cycles 1

Example

TSTB *-AR4(1),R5

Before Instruction		After Instruction	
AR4	80 99C5h	AR4	80 99C5h
R5	898h	R5	898h
	2200		2200
Data at 80 99C4h	767h	Data at 80 99C4h	767h
	1895		1895
LUF	0	LUF	0
LV	0	LV	0
UF	0	UF	0
N	0	N	0
Z	0	Z	1
V	0	V	0
C	0	C	0

Syntax **TSTB3** *src2, src1*

Operands *src1, src2*: type 1 or type 2 three-operand addressing modes

Opcode

Type 1

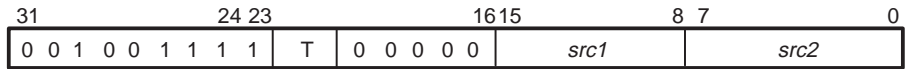

Type 2

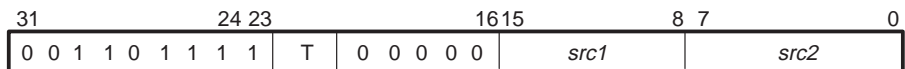

Word Fields

Type 1

	T <i>src1</i> addressing modes	<i>src2</i> addressing modes
00	register mode (any CPU register)	register mode (any CPU register)
01	indirect mode (disp = 0, 1, IR0, IR1)	register mode (any CPU register)
10	register mode (any CPU register)	indirect mode (disp = 0, 1, IR0, IR1)
11	indirect mode (disp = 0, 1, IR0, IR1)	indirect mode (disp = 0, 1, IR0, IR1)

Type 2

	T <i>src1</i> addressing modes	<i>src2</i> addressing modes
00	register mode (any CPU register)	8-bit signed immediate
01	register mode (any CPU register)	indirect mode *+ARn(5-bit unsigned displacement)
10	indirect mode *+ARn(5-bit unsigned displacement)	8-bit signed immediate
11	indirect mode *+ARn1(5-bit unsigned displacement)	indirect mode *+ARn2(5-bit unsigned displacement)

Operation *src1* AND *src2*

Description The bitwise-logical AND between the *src1* and *src2* operands is performed but is not loaded into any register. This allows for nondestructive compares. The *src1* and *src2* operands are assumed to be unsigned integers. The *src2* immediate-addressing mode is sign-extended.

Although this instruction has only two operands, it is designated as a three-operand instruction because operands are specified in the three-operand format.

Status Bits	LUF	Unaffected
	LV	Unaffected
	UF	0
	N	MSB of the output
	Z	1 if a zero output is generated, 0 otherwise
	V	0
	C	Unaffected
Mode Bit	OVM operation is not affected by OVM bit value.	
Cycles	1	
Example	None	

Syntax **XOR** *src, dst*

Operands
src: general-addressing modes (G)
dst: register (any register in CPU primary-register file)

Opcode

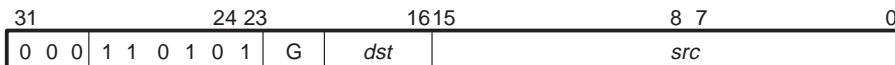

Word Fields

G	<i>src</i> addressing modes
00	register (any register in CPU primary-register file)
01	direct
10	indirect
11	immediate

Operation *dst XOR src* → *dst*

Description The bitwise-exclusive OR of the *src* and *dst* operands is loaded into the *dst* register. The *dst* and *src* operands are assumed to be unsigned integers.

Status Bits If ST (SETCOND) = 0 and the destination register is R0 – R11, the condition flags are modified. If ST (SETCOND) = 1, they are modified for all destination registers.

LUF Unaffected
LV Unaffected
UF 0
N MSB of the output
Z 1 if a zero output is generated, 0 otherwise
V 0
C Unaffected

Mode Bit OVM operation is not affected by OVM bit value.

Cycles 1

Example

XOR R1,R2

Before Instruction		After Instruction	
R1	0F FA32h	R1	0F F412h
R2	0F F5C1h	R2	00 0FF3h
LUF	0	LUF	0
LV	0	LV	0
UF	0	UF	0
N	0	N	0
Z	0	Z	0
V	0	V	0
C	0	C	0

Syntax **XOR3** *src2, src1, dst*

Operands *src1, src2*: type 1 or type 2 three-operand addressing modes
dst: register mode (any register in CPU primary-register file)

Opcode

Type 1

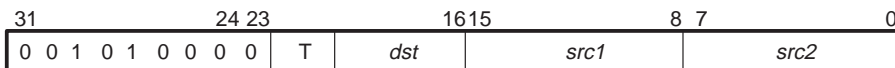

Type 2

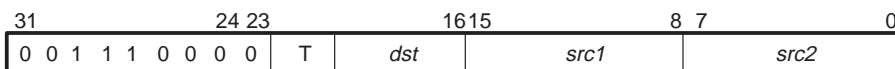

Word Fields

Type 1

	T <i>src1</i> addressing modes	<i>src2</i> addressing modes
00	register mode (any CPU register)	register mode (any CPU register)
01	indirect mode (disp = 0, 1, IR0, IR1)	register mode (any CPU register)
10	register mode (any CPU register)	indirect mode (disp = 0, 1, IR0, IR1)
11	indirect mode (disp = 0, 1, IR0, IR1)	indirect mode (disp = 0, 1, IR0, IR1)

Type 2

	T <i>src1</i> addressing modes	<i>src2</i> addressing modes
00	register mode (any CPU register)	8-bit signed immediate
01	register mode (any CPU register)	indirect mode *+ARn(5-bit unsigned displacement)
10	indirect mode *+ARn(5-bit unsigned displacement)	8-bit signed immediate
11	indirect mode *+ARn1(5-bit unsigned displacement)	indirect mode *+ARn2(5-bit unsigned displacement)

Operation

src1 XOR *src2* → *dst*

Description	The bitwise-exclusive OR between the <i>src1</i> and <i>src2</i> operands is loaded into the <i>dst</i> register. The <i>src1</i> , <i>src2</i> , and <i>dst</i> operands are assumed to be unsigned integers. The <i>src2</i> immediate-addressing mode is sign-extended.
Status Bits	If ST (SETCOND) = 0 and the destination register is R0 – R11, the condition flags are modified. If ST (SETCOND) = 1, they are modified for all destination registers. LUF Unaffected LV Unaffected UF 0 N MSB of the output Z 1 if a zero output is generated, 0 otherwise V 0 C Unaffected
Mode Bit	OVM operation is not affected by OVM bit value.
Cycles	1
Example	None

Syntax **XOR3** *src2, src1, dst1*
 || **STI** *src3, dst2*

Operands *src1*: register (R0 – R7)
 src2: indirect (disp = 0, 1, IR0, IR1)
 dst1: register (R0 – R7)
 src3: register (R0 – R7)
 dst2: indirect (disp = 0, 1, IR0, IR1)

Opcode

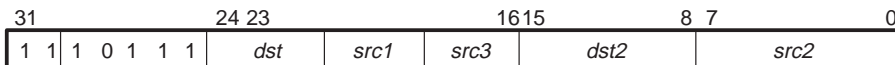

Word Fields None

Operation *src1 XOR src2* → *dst1*
 || *src3* → *dst2*

Description A bitwise-exclusive XOR and an integer store are performed in parallel. All registers are read at the beginning and loaded at the end of the execute cycle. This means that if one of the parallel operations (STI) reads from a register and the operation being performed in parallel (XOR3) writes to the same register, then STI accepts as input the contents of the register before it is modified by the XOR3.

If *src2* and *dst2* point to the same location, *src2* is read before the write to *dst2*.

Status Bits **LUF** Unaffected
 LV Unaffected
 UF 0
 N MSB of the output
 Z 1 if a zero output is generated, 0 otherwise
 V 0
 C Unaffected

Mode Bit OVM operation is not affected by OVM bit value.

Cycles 1

Example

```

XOR3 *AR1++,R3,R3
|| STI R6,*-AR2(IR0)

```

Before Instruction		After Instruction	
AR1	80 987Eh	AR1	80 987Fh
R3	85h	R3	0h
R6	0DCh	R6	0DCh
AR2	80 98B4h	AR2	80 98B4h
IR0	8h	IR0	8h
Data at 80 987Eh	85h	Data at 987Eh	85h
Data at 80 98ACh	0h	Data at 80 98ACh	0DCh
LUF	0	LUF	0
LV	0	LV	0
UF	0	UF	0
N	0	N	0
Z	0	Z	0
V	0	V	0
C	0	C	0

220

220

220

Glossary

A

A0–A30: External address pins for data/program memory or I/O devices. These pins are on the global bus. *See also LA0–LA30.*

address: The location of program code or data stored in memory.

addressing mode: The method by which an instruction interprets its operands to acquire the data it needs.

ALU: *See Arithmetic logic unit.*

analog-to-digital (A/D) converter: A successive-approximation converter with internal sample-and-hold circuitry used to translate an analog signal to a digital signal.

ARAU: *See auxiliary-register arithmetic unit.*

arithmetic logic unit (ALU): The part of the CPU that performs arithmetic and logic operations.

auxiliary registers (ARn): A set of registers used primarily in address generation.

auxiliary-register arithmetic unit (ARAU): *Auxiliary-register arithmetic unit.* A 32-bit arithmetic logic unit (ALU) used to calculate indirect addresses using the auxiliary registers as inputs and outputs.

B

bit-reversed addressing: Addressing in which several bits of an address are reversed in order to speed processing of algorithms, such as Fourier transforms.

BK: *See block-size register.*

bootloader: An on-chip code that transfers code from an external memory or from a communication port to RAM at power-up.

C

carry bit: A bit in status register ST used by the ALU for extended arithmetic operations and accumulator shifts and rotates. The carry bit can be tested by conditional instructions.

circular addressing: An addressing mode in which an auxiliary register is used to cycle through a range of addresses to create a circular buffer in memory.

context save/restore: A save/restore of system status (status registers, accumulator, product register, temporary register, hardware stack, and auxiliary registers, etc.) when the device enters/exits a subroutine such as an interrupt service routine.

CPU: *Central processing unit.* The unit that coordinates the functions of a processor.

CPU cycle: The time it takes the CPU to go through one logic phase (during which internal values are changed) and one latch phase (during which the values are held constant).

cycle: See CPU cycle.

D

D0–D31: External data-bus pins that transfer data between the processor and external data/program memory or I/O devices. *See also LD0–LD31.*

data-address generation logic: Logic circuitry that generates the addresses for data-memory reads and writes. This circuitry can generate one address per machine cycle. *See also program address generation logic.*

data-page pointer: A 32-bit register used as the 16 MSBs in addresses generated using direct addressing.

decode phase: The phase of the pipeline in which the instruction is decoded (identified).

DIE: See DMA interrupt enable register.

DMA coprocessor: A peripheral that transfers the contents of memory locations independently of the processor (except for initialization).

DMA controller: See DMA coprocessor.

DMA interrupt enable register (DIE): A register (in the CPU register file) that controls which interrupts the DMA coprocessor responds to.

DP: See data-page pointer.

dual-access RAM: Memory that can be accessed twice in a single clock cycle. For example, your code can read from and write to a dual-access RAM in one clock cycle.

E

external interrupt: A hardware interrupt triggered by a pin.

extended-precision floating-point format: A 40-bit representation of a floating-point number with a 32-bit mantissa and an 8-bit exponent.

extended-precision register: A 40-bit register used primarily for extended-precision floating-point calculations. Floating-point operations use bits 39–0 of an extended-precision register. Integer operations, however, use only bits 31–0.

F

FIFO buffer: *First-in, first-out buffer.* A portion of memory in which data is stored and then retrieved in the same order in which it was stored. Thus, the first word stored in this buffer is retrieved first. The 'C4x's communication ports each have two FIFOs: one for transmit operations and one for receive operations.

H

hardware interrupt: An interrupt triggered through physical connections with on-chip peripherals or external devices.

hit: A condition in which, when the processor fetches an instruction, the instruction is available in the cache.

I

$\overline{\text{IACK}}$: *Interrupt acknowledge signal.* An output signal that indicates that an interrupt has been received and that the program counter is fetching the interrupt vector that will force the processor into an interrupt service routine.

IIE: See internal interrupt enable register.

IIF: See IIOF flag register.

IIOF flag register (IIF): Controls the function (general-purpose I/O or interrupt) of the four external pins ($\overline{\text{IIOF0}}$ to $\overline{\text{IIOF3}}$). It also contains timer/DMA interrupt flags.

index registers: Two registers (IR0 and IR1) that are used by the ARAU for indexing an address.

internal interrupt: A hardware interrupt caused by an on-chip peripheral.

internal interrupt enable register: A register (in the CPU register file) that determines whether or not the CPU will respond to interrupts from the communication ports, the timers, and the DMA coprocessor.

interrupt: A signal sent to the CPU that (when not masked) forces the CPU into a subroutine called an interrupt service routine. This signal can be triggered by an external device, an on-chip peripheral, or an instruction (TRAP, for example).

interrupt acknowledge ($\overline{\text{IACK}}$): A signal that indicates that an interrupt has been received, and that the program counter is fetching the interrupt vector location.

interrupt vector table (IVT): An ordered list of addresses which each correspond to an interrupt; when an interrupt occurs and is enabled, the processor executes a branch to the address stored in the corresponding location in the interrupt vector table.

interrupt vector table pointer (IVTP): A register (in the CPU expansion register file) that contains the address of the beginning of the interrupt vector table.

ISR: *Interrupt service routine.* A module of code that is executed in response to a hardware or software interrupt.

IVTP: See *interrupt vector table pointer.*

L

LA0–LA30: External address pins for data/program memory or I/O devices. These pins are on the local bus. See also A0–A30.

LD0–LD31: External data bus pins that transfer data between the processor and external data/program memory or I/O devices. See also D0–D31.

LSB: *Least significant bit.* The lowest order bit in a word.

M

machine cycle: See *CPU cycle*.

mantissa: A component of a floating-point number consisting of a fraction and a sign bit. The mantissa represents a normalized fraction whose binary point is shifted by the exponent.

maskable interrupt: A hardware interrupt that can be enabled or disabled through software.

memory-mapped register: One of the on-chip registers mapped to addresses in memory. Some memory-mapped registers are mapped to data memory, and some are mapped to input/output memory.

MFLOPS: *Millions of floating point operations per second.* A measure of floating-point processor speed that counts of the number of floating-point operations made per second.

microcomputer mode: A mode in which the on-chip ROM (bootloader) is enabled. This mode is selected via the MP/\overline{MC} pin. See also *MP/ \overline{MC} pin*; *microprocessor mode*.

microprocessor mode: A mode in which the on-chip ROM is disabled. This mode is selected via the MP/\overline{MC} pin. See also *MP/ \overline{MC} pin*; *microcomputer mode*.

MIPS: Million instructions-per-second.

miss: A condition in which, when the processor fetches an instruction, it is not available in the cache.

MSB: *Most significant bit.* The highest order bit in a word.

multiplier: A device that generates the product of two numbers.

N

\overline{NMI} : See *Nonmaskable interrupt*.

nonmaskable interrupt (NMI): A hardware interrupt that uses the same logic as the maskable interrupts but cannot be masked.

O

overflow flag (OV) bit: A status bit that indicates whether or not an arithmetic operation has exceeded the capacity of the corresponding register.

P

PC: See *program counter*.

peripheral bus: A bus that is used by the CPU to communicate the DMA coprocessor, communication ports, and timers.

pipeline: A method of executing instructions in an assembly-line fashion.

program counter: A register that contains the address of the next instruction to be fetched.

R

RC: See *repeat counter register*.

read/write ($\overline{R/\overline{W}}$) pin: This memory-control signal indicates the direction of transfer when communicating to an external device.

register file: A bank of registers.

repeat counter register: A register (in the CPU register file) that specifies the number of times minus one that a block of code is to be repeated when a block repeat is performed.

repeat mode: A zero-overhead method for repeating the execution of a block of code.

reset: A means to bring the central processing unit (CPU) to a known state by setting the registers and control bits to predetermined values and signaling execution to fetch the reset vector.

reset pin: This pin causes the device to reset.

ROMEN: *ROM enable*. An external pin that determines whether or not the on-chip ROM is enabled.

$\overline{R/\overline{W}}$: See *read/write pin*.

S

short floating-point format: A 16-bit representation of a floating point number with a 12-bit mantissa and a 4-bit exponent.

short integer format: A twos-complement, 16-bit format for integer data.

short unsigned-integer format: A 16-bit unsigned format for integer data.

sign-extend: Fill the high order bits of a number with the sign bit.

single-precision floating-point format: A 32-bit representation of a floating-point number with a 24-bit mantissa and an 8-bit exponent.

single-precision integer format: A twos-complement 32-bit format for integer data.

single-precision unsigned-integer format: A 32-bit unsigned format for integer data.

software interrupt: An interrupt caused by the execution of a TRAP instruction.

split mode: A mode of operation of the DMA coprocessor. This mode allows one DMA channel to service both the receive and transmit portions of a communication port.

ST: See status register.

stack: A block of memory reserved for storing and retrieving data on a first-in last-out basis. It is usually used for storing return addresses and for preserving register values.

status register: A register in the CPU register file that contains global information related to the CPU.

T

Timer: A programmable peripheral that can generate pulses or time events.

Timer-Period Register: *Timer-period register.* A 32-bit memory-mapped register that specifies the period for the on-chip timer.

trap vector table (TVT): An ordered list of addresses which each correspond to an interrupt; when a trap is executed, the processor executes a branch to the address stored in the corresponding location in the trap vector table.

trap vector table pointer (TVTP): A register in the CPU expansion register file that contains the address of the beginning of the trap vector table.

TVTP: See *trap vector table pointer*.

U

unified mode: A mode of operation of the DMA coprocessor. The mode is used mainly for memory-to-memory transfers. This is the default mode of operation for a DMA channel. See also *split mode*.

W

wait state: A period of time that the CPU must wait for external program, data, or I/O memory to respond when reading from or writing to that external memory. The CPU waits one extra cycle for every wait state.

wait-state generator: A program that can be modified to generate a limited number of wait states for a given off-chip memory space (lower program, upper program, data, or I/O).

Z

zero fill: Fill the low or high order bits with zeros when loading a number into a larger field.

Nu

- 16-bit wide configured memory
table 10-14
- 32-bit wide configured memory
table 10-15

A

- A/D converter
definition A-1
- A0-A30
definition A-1
- abbreviations 14-16
- ABS||STI instruction 14-31
- ABSF instruction 14-26
- ABSF||STF instruction 14-27
- ABSI instruction 14-29
- ADDC instruction 14-33
- ADDC3 instruction 14-35
- ADDF instruction 14-37
- ADDF3 instruction 14-39
- ADDF3||STF instruction 14-41
- ADDI instruction 14-43
- ADDI3 instruction 14-45
- ADDI3||STI instruction 14-47
- addition
floating-point 5-23
- address
definition A-1
- address buses
external 2-20
- address partitioning
figure 4-10
- address pins

- external A-4
- address range
 - LSTRB0 9-11
 - STRB0 9-10
- address space
 - caution 2-13
- addressing modes
 - bit-reversed addressing 6-32
 - circular 6-27
 - conditional branch 2-18
 - definition A-1
 - encoding **6-21**
 - conditional branch* **6-25**
 - general* 6-21
 - parallel* **6-24**
 - three-operand* **6-22**
 - general 2-18
 - groups 6-21
 - parallel 2-18
 - three operand 2-18, 6-22
- addressing types 6-2
 - direct addressing 6-5
 - immediate 6-18
 - indirect addressing 6-6 to 6-21
 - PC relative 6-19
 - register 6-3
- AE bit 9-7
- aliasing 2-17
- ALU. *See* arithmetic logic unit; arithmetic logic unit (ALU)
- analysis bit 3-7
- analysis module
 - registers 4-6
- AND instruction 14-49
- AND||STI instruction 14-53
- AND3 instruction 14-51
- ANDN instruction 14-55
- ANDN3 instruction 14-57
- application(s)
 - automotive viii, xiv
 - consumer viii, xiv
 - control viii, xii
 - development support viii, xv
 - general-purpose viii
 - graphics/imagery viii, xi
 - medical viii, xiv
 - military viii, xiii
 - multimedia viii, xiii
 - speech/voice viii, xi
 - telecommunications viii, xiii

ARAUs. *See* auxiliary register arithmetic units (ARAUs)

architectural overview

introduction 2-1

architecture

peripheral bus 2-22

arithmetic logic unit (ALU) 2-4

definition A-1

ASH instruction 14-59

ASH3 instruction 14-61

ASH3||STI instruction 14-63

assembly language instructions 14-2 to 14-11

condition codes

flags 14-12

example instruction 14-23

illegal instructions 14-11

interlocked operation 14-8

load and store 14-2

parallel operation 14-9

program control 14-7

register symbols 14-21 to 14-22

symbols 14-17 to 14-22

syntax options 14-18 to 14-22

three-operand 14-6

two-operand 14-4

autoinitialization 11-34

consecutive 11-40

situations 11-34

synchronization 11-37

automotive applications viii, xiv

auxiliary link-pointer register 11-7

auxiliary register

indirect 6-9

auxiliary register arithmetic units (ARAUs) 2-6

auxiliary registers (AR0–7) 2-6, **3-4**

auxiliary registers (ARn)

definition A-1

auxiliary transfer-counter register 11-7

auxiliary-register arithmetic unit (ARAU)

definition A-1

B

Bcond instruction 14-65

BcondAF instruction 7-11, 8-7, 14-67

example 8-7

BcondAT instruction 7-11, 8-7, 14-69

example 8-7

BcondD instruction 14-71

- bit-reversed addressing 6-32
 - definition A-1
 - example 6-32
 - index steps 6-33
- block diagram
 - 'C4x 2-2
 - communication ports 12-4
 - peripheral modules 2-22
 - timers 13-3
- block repeat
 - nesting 7-8
 - registers (RC, RE, RS) 3-16, **7-2**
- block size (BK) register **3-5**
- block transfer completion 11-6
- block transfer sequence 11-5
- bootloader
 - definition A-2
 - description 10-2
 - from communication port 10-3
 - from memory 10-3
 - introduction 10-1
 - mode selection 10-3
 - operation 10-5
 - setting the IIOF pins 10-19
 - source code 10-20 to 10-25
 - source structure 10-8
- bootloader mode selection
 - table 10-3
- bootloading
 - from a comm port 10-16
 - from memory 10-10
 - sequence 10-5
- BR instruction 14-73
- branch conflicts 8-4
- branch execution
 - delayed 7-10
- branches 7-9, 7-12
- BRD instruction 14-74
- bus operation
 - external 2-20, 9-1 to 9-50
 - internal 2-19
- busy-waiting example 9-42
- byte-wide configured memory
 - table 10-11 to 10-14

C

C flag 3-5

'C40 memory map
figure 2-14, **4-3**

'C40/'C44 features
table 1-4

'C44 memory aliasing
figure 2-17

'C44 memory map **4-4**
figure 2-15

'C4x multiprocessor system
booting example 10-17

'C4x to IEEE conversion
example 5-18

'C4x-specific instructions 14-3 to 14-8

cache 4-1

cache clear (CC) bit 4-12

cache enable (CE) bit 4-12

cache freeze (CF) bit 4-12

cache memory 2-11, 4-13
architecture 2-11, 4-10
control bits 4-12
enabling 4-13
hit 4-14
instruction cache 4-10
LRU algorithm 4-14
miss 4-14
segment miss 4-14
subsegment miss 4-14

CALL instruction 7-12, **14-75**

CALL response timing
figure 7-14

CALLcond instruction 7-12, **14-76**

calls 7-12

carry bit
definition A-2

CC bit 3-6, 4-12

CE and CF bits
combined effect
table 4-13
table 3-7

CE bit 3-6, 4-12

CE0 bit 9-7

CE1 bit 9-7

central processing unit. *See* CPU

CF bit 3-6, 4-12

channel control register. *See* DMA channel control register

channel priority scheme
split mode 11-25

- circular addressing
 - definition A-2
 - example 6-30
 - FIR filters 6-31
 - register relationships
 - figure 6-28*
- circular addressing mode 6-27
- circular buffer
 - implementation 6-29
- CLKSRC = 0 and FUNC = 0 13-14
- CLKSRC = 0 and FUNC = 1 13-14
- CLKSRC = 1 and FUNC = 0 13-13
- CMPF instruction 14-78
- CMPF3 instruction 14-80
- CMPI instruction 14-82
- CMPI3 instruction 14-84
- communication port load mode
 - flow chart 10-7
- communication port memory map
 - figure 12-7*
- communication port reset
 - example 12-10
- communication port software register 12-3
- communication ports
 - arbitration unit 12-3, **12-11**
 - block diagram 12-4
 - control register 12-3
 - coordination with CPU/DMA 12-17
 - CSTRB width restrictions 12-25
 - features 2-23, 12-2
 - H1/H3 synchronization 12-26
 - input FIFO halt 12-15
- communication ports (continued)
 - input port post-reset state 12-31
 - input port register 12-9
 - interconnection 12-5
 - introduction 12-1
 - memory map 4-8, 12-7
 - figure 4-8*
 - output FIFO halt 12-15
 - output port post-reset state 12-30
 - output port register 12-9
 - reset 12-29
 - tips 12-32
 - token transfer 12-19
- communication-port control register (CPCR) 12-8
 - field descriptions 12-8
 - figure 12-8*
 - ICH 12-8

- INPUT LEVEL 12-9
- OCH 12-8
- OUTPUT LEVEL 12-9
- PORT DIR 12-8
- communication-port software
 - reset address
 - table 12-10*
 - reset register 12-10
- condition codes
 - flags 14-14
- conditional-branch addressing modes 2-18, 6-25
 - encoding 6-26
- consecutive autoinitializations 11-40
- consumer applications viii, xiv
- context save/restore
 - definition A-2
- control applications viii, xii
- control bits
 - repeat mode 7-3
- control registers 7-35, 11-7, 13-5
- conversion of format
 - 'C4x floating-point to integer 5-31
 - extended-precision floating-point to single-precision floating-point 5-12
 - FRIEEE instruction 14-98
 - IEEE single precision std. 754 5-13
 - IEEE to 'C4x floating-point 5-14
 - integer to floating-point 5-33
 - short floating-point to extended-precision floating-point 5-11
 - short floating-point to single-precision floating-point 5-11
 - single-precision 'C4x floating-point 5-13
 - single-precision floating-point to extended-precision floating-point 5-12
 - TOIEEE instruction 14-265
- converting IEEE format
 - table 5-14*
- converting twos complement
 - table 5-17*
- counter register 13-5
- CPU 2-4
 - arbitration 11-27
 - block diagram 2-5
 - buses 2-19
 - components 2-4
 - communication ports coordination 12-17
 - definition A-2
 - internal interrupt enable register (IIE) 2-9, **3-11**
 - primary register file 2-6
- CPU cycle
 - definition A-2
- CPU expansion register file

- definition 3-1
- CPU primary register file 3-2
 - definition 3-1
- CPU registers 2-7, 3-8, 7-36
 - auxiliary (AR0–AR7) 2-6, **3-4**
 - block repeat (RC, RE, RS) **3-16**
 - block size (BK) 2-8, **3-5**
 - data page pointer (DP) 2-8, **3-4**, 6-5
 - DMA interrupt enable (DIE) 2-9, 3-8, **11-44**
 - expansion register file 2-10, 3-17
 - extended precision (R0-R11) 2-6, **3-3**
 - IIE 3-11
 - IIOF flag register (IIF) 2-9, **3-13**
 - index (IR1, IR0) 2-8, **3-4**
 - internal interrupt enable (IIE) 2-9, **3-11**, 3-12
 - introduction 3-1
 - program counter (PC) 2-9, 2-19, **3-16**
 - repeat count (RC) 2-9, 3-16, 7-2
 - repeat end address (RE) 3-16, 7-2
 - See also repeat block (RC, RE, RS)*
 - repeat start address (RS) 3-16, 7-2
 - See also repeat block (RC, RE, RS)*
 - stack pointer (SP) 2-8, **3-5**
 - status register (ST) 2-9, **3-5**, 14-13
 - table 3-2, 6-3
 - timer 4-7
- CSTRB width restrictions 12-25

D

- D0-D31
 - definition A-2
- data buses
 - external 2-20
- data formats
 - introduction 5-1
- data page pointer (DP) 2-8, **3-4**, 6-5
- data structure
 - FIR filters 6-31
- data transfer modes 11-28
- data transfer operation 12-6
- data-address generation logic
 - definition A-2
- data-page pointer
 - definition A-2
- DBcond instruction 14-86
- DBcondD instruction 14-88
- DBR instruction 8-9
- DE bit 9-7

decode phase
 definition A-2

delayed branches 7-9
 conditional 7-9
 disabled interrupts 7-9
 example 7-10
 incorrectly placed 7-10
 example 7-7
 with annul option 8-7
 with annulling 7-11
 without annul option 8-6
 example 8-6
 without annulling 7-10

destination address register 11-7

destination address-index register 11-7

development support applications viii, xv

DIE register bit functions
 DMA split mode 11-45

direct addressing 6-5
 example 6-5
 figure 6-5

direct memory access. *See* DMA coprocessor

displacement
 indirect addressing
 table 6-7

displacements 6-6 to 6-21

DMA channel control register 7-35, 11-7
 bit definitions 11-8
 data transfer modes 11-28
 field descriptions 11-8
 modifiable by autoinitialization in split mode 11-40
 modifiable by autoinitialization in unified mode 11-39
 modifiable by autoinitialization of auxiliary channel 11-40

DMA channel control register bit definitions
 AUTOINIT STATIC 11-8
 AUTOINIT SYNC 11-9
 AUX AUTOINIT STATIC 11-9
 AUX AUTOINIT SYNC 11-9
 AUX START 11-10
 AUX STATUS 11-11
 AUX TCC 11-10
 AUX TCINT FLAG 11-10
 AUX TRANSFER MODE 11-8
 COM PORT 11-9
 DMA PRI 11-8
 PRIORITY MODE 11-11
 READ BIT REV 11-9
 SPLIT MODE 11-9
 START 11-10

STATUS 11-11
SYNC MODE 11-8
TCC 11-10
TCINT FLAC 11-10
TRANSFER MODE 11-8
WRITE BIT REV 11-9

DMA channel registers
(SPLIT MODE=1, auxiliary transfer counter = 0)
figure 11-36
storage in memory (SPLIT MODE=0)
figure 11-35
storage in memory (SPLIT MODE=1)
figure 11-36

DMA channel running
transfer mode 102
figure 11-29, 11-30
transfer mode 112
figure 11-31, 11-33

DMA control register bits
effect 11-38

DMA controller 2-19

- DMA coprocessor 2-23
 - address generation
 - figure 11-16*
 - address registers 11-15
 - arbitration 11-27
 - autoinitialization 11-34
 - auxiliary channel 11-20
 - block transfer sequence 11-5
 - buses 2-19
 - channel arbitration 11-24
 - channel configuration
 - figure 11-19*
 - channel register map 4-9, **11-4**
 - channel synchronization 11-43 to 11-46
 - communication ports coordination 12-17
 - definition A-2
 - destination synchronization 11-48
 - features 11-2
 - functional description 11-3
 - index registers 11-15
 - interrupts 11-42
 - introduction 11-2
 - link-pointer register 11-17
 - memory map **11-4**
 - operational modes 11-3
 - primary channel 11-20
 - priorities 11-22
 - priority wheel 11-24
 - registers 11-5, **11-7**
 - six channels 2-23
 - source and destination synchronization 11-49
 - source synchronization 11-48
 - split mode 3-10, **11-20**
 - timing 11-51
 - transfer count register 11-16
 - transfer modes 11-28
 - unified mode 3-8, 11-19
- DMA coprocessor memory map
 - figure 4-9*
- DMA destination synchronization
 - figure 11-49*
- DMA interrupt enable register (DIE) 2-9, 3-8, **11-44**
 - bit functions 3-10
 - definition A-3
- DMA interrupts 7-26
 - control bits 7-26
 - CPU interaction 7-28
 - processing 7-27
- DMA memory transfer timing
 - single 11-51

DMA PRI and CPU/DMA arbitration rules 11-27
table 11-12

DMA registers initialization 11-5

DMA source and destination sync
unified mode 11-50

DMA source synchronization
figure 11-48

DMA start 11-5

DMA timing for different synchronizations
split mode
figure 11-56
unified mode
figure 11-55

DMA transfers
timing and number of cycles to global bus
figure 11-54
timing and number of cycles to local bus
figure 11-53
timing and number of cycles to on-chip
figure 11-52

DMAINTx flag 3-15

documentation vii

dual-access RAM
definition A-3

E

edge-triggered interrupts 7-15

EDMAINTx bit 3-12

EICFULLx bit 3-12

EICRDYx bit 3-12

EIIFOx bit 3-14

EOEMPTYx bit 3-12

EOCRDYx bit 3-12

ETINT0 bit 3-12

ETINT1 bit 3-12

execute only 8-10, 8-13
parallel store 8-14
single store 8-13

expansion register file 2-10, **3-17**
interrupt vector table (IVT) 7-16

exponent field
definition 5-8

extended precision registers **3-3**

extended-precision floating-point format
definition A-3

- extended-precision register
 - definition A-3
 - floating-point format 3-4
 - integer format 3-4
- external bus
 - control registers. See memory interface control registers
 - interface signals 9-3
- external bus operation 9-1 to 9-50
 - overview 9-2
- external buses (global, local), wait states 9-14
- external interrupts 2-21, **7-21**
 - definition A-3
- external memory interface registers 7-35

F

- features comparison 1-4
- FIFO buffer
 - definition A-3
- FIFOS
 - halting 12-14
- FIR filters
 - circular addressing 6-31
 - data structure 6-31
- FIX instruction 5-31, 14-90
- FIX||STI instruction 14-92
- fixed priority 11-22
- FLAGx bit 3-14
- FLOAT instruction 5-33, 14-94
- FLOAT||STF instruction 14-96
- floating point
 - addition 5-23
 - conversion to integer 5-31
 - extended-precision format 5-7
 - format conversion 5-11
 - formats 5-4
 - normalization 5-23, 5-27
 - reciprocal 5-34
 - register format 3-4
 - rounding value 5-29
 - single-precision format 5-6
- floating point (continued)
 - subtraction 5-23
 - underflow 5-24
- floating-point
 - determining decimal equivalent 5-8
 - extended-precision format 5-7
 - general format 5-4

- multiplication 5-19
- short format 5-5
 - figure 5-5*
- single-precision format
 - figure 5-6*
- floating-point addition
 - 32-bit shift 5-26
 - example 5-25
- floating-point addition/subtraction
 - example 5-26
- floating-point formats
 - IEEE Std. 754 5-13
 - supported types 5-4
- floating-point multiplication
 - chart 5-20
- floating-point multiply
 - mantissa = 1.0 5-22
 - mantissa = 1.5 5-21
 - mantissa = 2.0 5-21
 - positive and negative numbers 5-22
- floating-point operation
 - introduction 5-1
- floating-point rounding
 - flowchart 5-30
- floating-point subtraction
 - example 5-25
- floating-point to integer conversion
 - flowchart 5-32
- floating-point values
 - fractional 5-10
 - negative 5-10
 - positive 5-9
- floating-point/integer multiplier 2-4
- format
 - conversion
 - 'C4x to IEEE 5-17*
 - conversions
 - IEEE std. 754 5-13*
- formats
 - conversion
 - floating-point 5-11*
 - See also conversion of formats*
- formats (continued)
 - signed integer 5-2
 - unsigned integer 5-3
- FRIEEE instruction 14-98
- FRIEEE|STF instruction 14-99
- FUNCx bit 3-14

G

general addressing modes 2-18, 6-21
 encoding 6-22
 general-purpose applications viii
 GIE bit 3-7
 global and local memory
 interface control signals 9-3
 global memory 9-39, 9-41, 9-43
 interface 2-20, 9-2
 table 9-4
 global memory port status
 STRB0 and STRB1 accesses 9-5
 graphics/imagery applications viii, xi

H

halting of FIFOs 12-14
 hardware interrupt
 definition A-3
 hit
 cache 4-14
 definition A-3
 hold everything 8-10, 8-15
 busy external port 8-15
 conditional calls and traps 8-16
 multicycle data reads 8-16

I

$\overline{\text{IACK}}$
 definition A-3
 $\overline{\text{IACK}}$ instruction 9-49, 14-100
 $\overline{\text{IACK}}$ pin 9-49
 timing 9-49
 ICFULL interrupt
 description 12-17
 enabling 3-12
 ICRDY flag
 interrupt use 11-46
 ICRDY interrupt
 description 12-17
 enabling 3-12
 interrupt use 3-9, 3-10, 11-44, 11-45
 IDLE instruction 14-102, 14-103
 IEEE std. 754 (conversions) 5-13
 IEEE to 'C4x conversion

- example 5-16
- IIE register 3-11
- IIF register 7-17
- IIF register modification 3-13
 - figure 7-18
- $\overline{\text{IIOF}}$ flag register (IIF) 2-9, **3-13**
 - definition A-4
- $\overline{\text{IIOF}}$ pins
 - boot loader use 10-5
 - modification 10-19
- immediate addressing 6-18
 - example 6-18
- index registers (IR0, IR1) 2-8, **3-4**, 11-15
 - definition A-4
- indirect addressing 6-6
 - displacement 6-7
 - flexibility 6-6
 - index register IR1 6-8
 - index register IRO 6-7
 - operand coding
 - figure 6-6*
 - postdisplacement add and circular modify 6-12
 - postdisplacement add and modify 6-11
 - postdisplacement subtract and circular modify 6-13
 - postdisplacement subtract and modify 6-12
 - postindex add and bit-reversed modify 6-17
 - postindex add and circular modify 6-16
 - postindex add and modify 6-15
 - postindex subtract and circular modify 6-17
 - postindex subtract and modify 6-16
 - preplacement add 6-9
 - preplacement add and modify 6-10
 - preplacement subtract 6-10
 - preplacement subtract and modify 6-11
 - preindex add 6-13
 - preindex add and modify 6-14
 - preindex subtract 6-14
 - preindex subtract and modify 6-15
 - special cases 6-8
- individual instruction descriptions 14-20
- input and output FIFO halting
 - summary 12-14
- input FIFO channel 12-3
- instruction cache 4-10
 - architecture 4-10
 - figure 4-11*
 - reset 4-12
- instruction register (IR) 2-19

instruction set summary **14-2 to 14-11**
functional groups 14-2

instructions
See also assembly language
interlocked 9-44

integer
short format 5-2
short unsigned format 5-3
signed formats 5-2
single-precision unsigned format 5-3
single-precision format 5-2
unsigned formats 5-3

integer formats
short integer 5-2
signed 5-2

interlocked instructions 2-20, **9-39**, 9-44

interlocked operations 9-39

interlocked operations instructions
table 14-8

internal buses 2-4, 2-19

internal interrupt
definition A-4

internal interrupt enable register (IIE) 2-9, **3-11**
definition A-4

internal interrupts 7-18

interrupt
definition A-4

interrupt acknowledge ($\overline{\text{IACK}}$)
definition A-4

interrupt acknowledge ($\overline{\text{IACK}}$) instruction 7-20

interrupt flag register (IIF)
figure 3-14

interrupt latency
table 7-21

interrupt service routine (ISR)
definition A-4

interrupt vector table (IVT) 7-15
boot loader use 10-8
definition A-4

interrupt vector table pointer (IVTP)
definition A-4

interrupts 2-21
control bits 7-17
DMA 7-28, 11-42
DMA interaction 7-28
edge triggered 11-42
edge-triggered 11-42
external 2-21, **7-21**

- initialization 7-24
- initiation condition 7-15
- latency 7-20
- level triggered 11-42
- level-triggered 11-42
- NMI 7-22
- overlapping the IVT and TVT 7-25
- prioritization 7-15
- processing 7-18, 7-19, 7-27, 7-28
- timer 13-12
- vector table 7-16
- vectors 7-28, 13-11

ISR. See interrupt service routine (ISR)

IVTP. See interrupt vector table (IVT)

IVTP register 2-10, 3-17

J

jumps 7-12

L

LA0-LA30

- definition A-4

LAJ instruction 7-13, **14-105**

LAJcond instruction 7-13, **14-106**

LATcond instruction 7-13, 7-25, **14-107**

LBb instruction 14-108

LBUb instruction 14-110

LD0-LD31

- definition A-4

LDA instruction 14-111

LDE instruction 14-112

LDEP instruction 14-114

LDF instruction 14-115

LDF||LDF instruction 14-121

LDF||STF instruction 14-123

LDFcond instruction 14-117

LDFI instruction 9-39, 9-45, 14-119

LDHI instruction 14-125

LDI instruction 14-126

LDI||LDI instruction 14-132

LDI||STI instruction 14-134

LDIcond instruction 14-128

LDII instruction 9-39, 9-45, **14-130**

LDM instruction 14-136

LDP instruction 14-138
 LDPE instruction 14-139
 LDPK instruction 14-140
 level-triggered interrupts 7-15
 LHUw instruction 14-143
 LHw instruction 14-141
 link pointer
 incrementing 11-36
 reference to 11-41
 self referential 11-41
 link pointer registers 11-7
 figure 11-18
 literature vii
 LLOCK signal 9-44
 load and store instructions
 table 14-3
 loading sequence
 bootloader 10-10
 local memory interface 2-20, 9-2
 LOCK signal 9-44
 low $\overline{\text{IOF}}$ signal
 circuit diagram 10-19
 LRU algorithm 4-14
 LRU stack 4-12
 LSB
 definition A-5
 LSH instruction 14-145
 LSH3 instruction 14-147
 LSH3|STI instruction 14-149
 LUF flag 3-5
 LV flag 3-5
 LWLct instruction 14-152
 LWRct instruction 14-154

M

machine values 14-21
 mantissa
 definition 5-8, A-5
 mapping addresses to strobes 9-12
 maskable interrupt
 definition A-5
 MBct instruction 14-156
 medical applications viii, xiv
 memory 2-11, 8-10
 See also memory interface

- accesses
 - pipeline* 8-19
 - timing* 8-19
 - addressing modes 2-18
 - aliasing 2-17
 - block diagram 2-12
 - cache 4-10, 4-13
 - communication ports memory map 12-7
 - control registers. *See* memory interface
 - global 9-39, 9-41, 9-43
 - introduction 4-1
 - maps 2-13, 4-2
 - maximizing pipeline performance 8-17
 - memory maps
 - communication ports* 4-8
 - DMA* 11-4
 - timer registers* 4-7, **13-5**
 - organization 2-11, 4-2
 - parallel multiplies and adds 8-23
 - parallel stores 8-21
 - pipeline conflicts 8-10
 - ranges 9-10
 - registers. *See* memory interface control registers
 - ROMEN pin 4-2
 - sharing 9-42
 - signal-group control 9-38
 - space 2-11
 - three-operand accesses 8-20
 - timing 8-19, 9-16
 - two-operand accesses 8-20
- memory accesses
- data access 8-17
 - data loads and stores 8-20
 - external program fetches 8-19
 - internal clock 8-19
 - internal program fetches 8-19
 - program fetch 8-17
 - two data accesses 8-18
- memory cache
- rules for efficient usage 4-13
- memory conflicts 8-4
- memory interface
- address ranges 9-11
 - control registers 9-6
 - control signals 9-3
 - page size 9-9
 - PAGESIZE field. *See* memory interface control registers
- memory interface (local, global)
- features 9-2
 - ready generation 9-14, 9-16

- timing 9-16
- wait states 9-14
- memory interface control registers 4-6
 - address ranges 9-10
 - bit contents 9-7
 - fields
 - figure 9-7*
 - figure 4-6
 - reset effect 9-6
 - STRBx SWW field 9-15
 - timing 9-16
 - wait states 9-14
- memory load
 - flow chart 10-6
- memory map 4-2
 - analysis module registers 4-6
 - 'C44 2-15
 - communication ports 4-8, **12-7**
 - DMA coprocessor
 - figure 4-9*
 - DMA 4-9, 11-4
 - global memory bus 9-12
 - peripheral 2-16
 - timer registers 4-7, 13-5
- memory-mapped register
 - definition A-5
- MFLOPS
 - definition A-5
- MHct instruction 14-158
- microcomputer mode
 - definition A-5
- microprocessor mode
 - definition A-5
- military applications viii, xiii
- MIPS
 - definition A-5
- miss
 - cache 4-14
 - definition A-5
- mode selection
 - bootloader 10-3
- mode selection flow
 - figure 10-4*
- module reset 12-29
- MPYF instruction 14-160
- MPYF3 instruction 14-162
- MPYF3||ADDF3 instruction 14-163
- MPYF3||STF instruction 14-165

MPYF3||SUBF3 instruction 14-167
MPYI instruction 14-169
MPYI3 instruction **14-171**
MPYI3||ADDI3 instruction 14-173
MPYI3||STI instruction 14-175
MPYI3||SUBI3 instruction 14-177
MPYSHI instruction 14-179
MPYSHI3 instruction, **14-180**
MPYUHI instruction 14-182
MPYUHI3 instruction 14-183
MSB
 definition A-5
multimedia applications viii, xiii
multiplication
 floating-point 5-19
multiplier
 definition A-5
multiply or CPU operation
parallel store 8-21

N

N flag 3-5
NEGB instruction 14-185
NEGF instruction 14-187
NEGF||STF instruction 14-189
NEGI instruction 14-191
NEGI||STI instruction 14-193
Newton-Raphson algorithm
 example 5-35
 reciprocal square root 5-38
NMI 7-22
NMI bus grant field 3-7
NMI flag 3-15
no DMA synchronization
 figure 11-47
nonmaskable interrupt (NMI)
 definition A-5
NOP instruction 14-195
NORM instruction 5-27, **14-196**
 execution 5-28
 flowchart 5-27
normalization
 floating point value 5-23, 5-27
NOT instruction 14-198
NOT||STI instruction 14-200

O

- object values
 - three-operand instructions 6-23
- OCEMPTY interrupt
 - description 12-17
 - enabling 3-12
- OCRDY flag
 - interrupt use 11-46
- OCRDY interrupt
 - description 12-17
 - enabling 3-12
 - interrupt use 3-9, 3-10, 11-44, 11-45
- operational overview
 - communication ports 12-3
- OR instruction 14-202
- OR3 instruction 14-204
- OR3||STI instruction 14-206
- output FIFO channel 12-3
- output value formats 14-12
- overflow 5-24, 5-31
- overflow flag (OV) bit
 - definition A-6
- OVM flag 3-6

P

- P flag (cache) 4-10
- page size 9-9
- page size operation 9-13
- parallel addressing modes 2-18, 6-24
- parallel instructions
 - table 14-9
- parallel multiplies and adds
 - figure 8-23
- parallel multiply with ADD/SUB
 - encoding 6-24
- PAU. *See* port arbitration unit
- PAU state definitions 12-11
- PCF bit 3-6
- PC-relative addressing
 - encoding 6-20
 - example 6-19
- period register 13-5
- peripheral
 - memory map 4-5

- peripheral modules
 - figure 2-22
- peripheral bus 2-22
 - definition A-6
 - general architecture 2-22
 - memory map 4-5
- peripheral memory map 2-16
- peripherals
 - communication port 2-23
- PGIE bit 3-7
- pin states
 - table 7-29 to 7-35
- pipeline
 - conflicts 8-4
 - branch* 8-4
 - memory* 8-10
 - register* 8-8
 - resolving (memory)* 8-17
 - decode unit 8-2
 - definition A-6
 - execute unit 8-2
 - fetch unit 8-2
 - four major units 8-2
 - introduction 8-1
 - memory accesses 8-19
 - read unit 8-2
 - structure 8-2
- pipeline structure
 - figure 8-3
- POP instruction 14-208
- POPF instruction **14-209**
- port arbitration unit 12-3, **12-11**
- previous cache freeze (PCF) bit 4-13
- primary register file (CPU) 2-6, 3-2
- prioritization 7-15
- priority wheel (DMA) 11-24
- program
 - buses 2-19
- program control instructions
 - table 14-7
- program counter (PC) 2-9, 2-19, **3-16**
 - definition A-6
- program fetch
 - multicycle program memory fetches 8-12
- program fetch incomplete 8-10, 8-12
- program wait 8-10
 - due to multicycle access 8-12
 - wait until CPU data access completes 8-11

PUSH instruction 14-210

PUSHF instruction **14-211**

R

RAM 2-11

RC register 7-4

RCPF instruction 5-34, 5-35, **14-212**

RCPF instruction algorithm

figure 5-34

read of AR 8-9

read/write (R/W) pin

definition A-6

ready

generation 9-14

timing 9-16

reciprocal (RCPF instruction) 5-34

reciprocal algorithm 5-35

reciprocal square root (RSQRF instruction) 5-36

register addressing 6-3

register bit functions

DMA unified mode

figure 3-8

register buses 2-19

register conflicts 8-4

register file

definition A-6

registers 2-6, 2-7

auxiliary (AR0–AR7) 2-6, **3-4**

block repeat (RC, RE, RS) **3-16**

block size (BK) 2-8, **3-5**

data page pointer (DP) 2-8, **3-4**, 6-5

DMA interrupt enable (DIE) 2-9, 3-8

expansion register file 2-10

extended precision **3-3**

extended precision (R0–R11) 2-6

I/O flag register (IIF) 2-9, **3-13**, 7-17, 7-26

index (IR1, IR0) **3-4**

input port 12-9

internal interrupt enable (IIE) 2-9, **3-11**, 3-12

output port 12-9

pipeline conflicts 8-8

program counter (PC) 2-9, 2-19, **3-16**

repeat count (RC) 2-9, **3-16**, 7-2

repeat end address (RE) 3-16, 7-2

See also repeat block (RC, RE, RS)

repeat mode 7-2

repeat start address (RS) 3-16, 7-2

See also repeat block (RC, RE, RS)

- stack pointer (SP) 2-8, **3-5**
- status register (ST) 2-9, **3-5**, 14-13
- timer counter 13-8
- timer global control 13-6
- repeat count register (RC) 2-9, 3-16, 7-2
 - definition A-6
- repeat end address register (RE) **7-2**
- repeat mode 7-2
 - block (RPTB) 7-2
 - block delayed (RPTBD) 7-2
 - control bits 7-3
 - definition A-6
 - nesting 7-8
 - operation 7-3
 - RC value after completion 7-7
 - restriction rules 7-6
 - RPTB instruction 7-4
 - RPTBD instruction 7-4
 - RPTS instruction 7-5
 - single instruction (RPTS) 7-2
- repeat mode flag 3-6
- repeat mode registers 7-2
- repeat start address register (RS) **7-2**
- repeat-mode control algorithm
 - example 7-4
- reserved bits 3-16
- reset **7-29**
 - additional operations 7-35
 - communication ports 12-29
 - definition A-6

reset (continued)
 memory interface control registers 9-6
 pin states 7-29
 vector location 7-35
 vectors 7-28
 $\overline{\text{RESET}}$ pin 12-29
 reset pin
 definition A-6
 RESETLOC pins 10-10
 RETIcond instruction 7-13, 7-24, **14-213**
 RETIcondD instruction 7-13, 7-24, **14-214**
 RETScond instruction 7-12, **14-215**
 returns 7-12
 RM bit 7-3
 RM flag 3-6
 RND instruction 5-29, **14-216**
 ROL instruction 14-218
 ROLC instruction 14-219
 ROM 2-11, 2-13
 ROMEN 2-13
 definition A-6
 ROMEN pin 2-11, 4-2
 ROR instruction 14-221
 RORC instruction 14-222
 rotating priority 11-22
 rotating priority DMA
 read and write sequence 11-23
 rotating priority mode
 figure 11-23
 rounding of floating-point value 5-29
 RPTB instruction 7-2, 7-8, 8-5, **14-223**
 pipeline conflict 7-7
 RPTB operation
 example 7-4
 RPTBD instruction 7-2, 7-8, 14-224
 RPTS execution
 steps 7-6
 RPTS instruction 7-2, 8-5, 14-226
 RSQRF instruction 5-36, **14-228**
 algorithm
 figure 5-37

S

S bit 7-3
 semaphores 9-43

- service sequence
 - split mode priority 11-26
- SET COND bit 3-7
- short floating-point format
 - definition A-7
- short integer format
 - definition A-7
- short unsigned-integer format
 - definition A-7
- SIGI instruction 9-39, 9-47, **14-229**
- signed-integer formats 5-2
- sign-extend
 - definition A-7
- single-precision floating-point format
 - definition A-7
- single-precision integer format
 - definition A-7
- single-precision unsigned-integer format
 - definition A-7
- software interrupt
 - definition A-7
- source address register 11-7
- source address-index register 11-7
- source and destination synchronization 11-49
- source synchronization 11-48
- speech/voice applications viii, xi
- split mode 3-10
 - definition A-7
- split mode (DMA) **11-20**, 11-35
- split-mode DMA configuration
 - figure 11-21
- split-mode synchronization interrupts
 - table 3-11
- stack
 - definition A-7
- stack pointer (SP) 2-8, **3-5**
- standard (nondelayed) branches 8-4
- standard branch 7-9
 - example 8-5
- START field descriptions
 - table 11-14
- state diagram
 - port arbitration unit 12-12
- STATUS field descriptions
 - table 11-14
- status register (ST) 2-9, **3-5**, 14-13
 - definition A-7

figure 3-5

STF instruction 14-230

STF||STF instruction 14-234

STFI instruction 9-39, 9-46, **14-232**

STI instruction 14-235

STI||STI instruction 14-237

STII instruction 9-39, 9-46, **14-236**

STIK instruction 14-239

STRB ACTIVE 9-8

STRB SWITCH 9-8

STRB0 PAGESIZE 9-8

STRB0 SWW 9-8

STRB0 WTCNT 9-8

STRB1 PAGESIZE 9-8

STRB1 SWW 9-8

STRB1 WTCNT 9-8

STRBx PAGESIZE fields
figure 9-13

strobe settings 9-7

strobes 9-12
timing 9-16

style (manual) iv

SUBB instruction **14-240**

SUBB3 instruction 14-242

SUBC instruction **14-244**

SUBF instruction 14-246

SUBF3 instruction 14-248

SUBF3||STF instruction 14-250

SUBI instruction 14-252

SUBI3 14-254

SUBI3||STI instruction 14-256

SUBRB instruction 14-258

SUBRF instruction 14-260

SUBRI instruction 14-262

subtraction
floating-point 5-23, 5-25

SWI instruction 14-264

symbols 14-16

symbols (used in manual) iv

sync mode
transfer rate 11-55

SYNC MODE and AUTOINIT MODE bits
autoinitialization
table 11-38

SYNC MODE bits 11-46

SYNC MODE field descriptions

split mode

table 11-13

unified mode

table 11-13

synchronization 11-37

destination 11-48

DMA channels 11-43

source 11-48

source and destination 11-49

synchronization interrupts

DMA channels 3-9

synchronizer delays 12-28

synchronizers 12-26

T

task counter example 9-42

TCLK 13-4

TCLK as an input

figure 13-15

TCLK as an output

figure 13-15

technical assistance xvi

telecommunications applications viii, xiii

three-operand addressing modes 2-18, 6-22

encoding for type 1 6-24

three-operand instruction word 8-20

three-operand instructions

table 14-6

timer

definition A-7

interrupts

considerations 13-12

timer clock setup

maximum setup 13-16

timer configuration

CLKSRC = 0 and FUNC = 0 13-14

CLKSRC = 0 and FUNC = 1 13-14

CLKSRC = 1 and FUNC = 0 13-13

CLKSRC = 1 and FUNC = 1 13-13

timer control register bit summary

C/P 13-7

CLKSRC 13-7

DATIN 13-6

timer control register bit summary (continued)

DATOUT 13-6

FUNC 13-6

- GO 13-6
- HLD 13-6
- I/O 13-6
- INV 13-7
- TSTAT 13-7
- timer global control register
 - diagram
 - bit summary* 13-6
- timer output generation
 - examples* 13-10
- timer pins 13-4
- timer pulse mode
 - clock mode timing 13-9
- timer registers 4-7, 7-35
 - figure 4-7
- timer-period register
 - definition A-7
- timers 2-24, 13-2, **13-2 to 13-3**
 - boundary conditions 13-8
 - control registers 13-5
 - counter register 13-2, 13-8
 - global control register **13-6**
 - I/O pin 2-24
 - initialization 13-16
 - interrupts 13-11
 - operation* 13-11
 - introduction 13-1
 - operation nodes 13-10
 - period register 13-2, 13-7
 - pulse generation 13-9
 - selecting CLKSRC 13-13
 - selecting FUNC 13-13
 - TCLK
 - general-purpose I/O* 13-15
- timing
 - DMA channels 11-51
 - $\overline{\text{IACK}}$ pin 9-49
 - memory access 9-16
 - STRB, RDY 9-16
- TINT0 flag 3-15
- TINT1 flag 3-15
- TMS320C40
 - introduction 1-2
- TMS320C44
 - introduction 1-2
- TMS320C4x
 - features comparison 1-4
 - introduction 1-1
 - key features 1-3

- TMS320C4x devices 1-2
- TOIEEE instruction 14-265
- TOIEEE||STF instruction 14-266
- token 12-3
- token transfer
 - figure 12-20
 - operation 12-5, 12-19
- token transfer sequence
 - table 12-21
- transfer counter registers
 - figure 11-17
- TRANSFER MODE = 002
 - running 11-28
- TRANSFER MODE = 012
 - running 11-29
- TRANSFER MODE = 102
 - running 11-29
- TRANSFER MODE = 112
 - running 11-31
- TRANSFER MODE field descriptions 11-28
 - table 11-12
- transfer rate
 - sync mode 11-55
- trap flow
 - figure 7-24
- TRAP instruction 7-25
- trap vector table (TVT)
 - boot loader use 10-9 to 10-10
 - definition A-7
- trap vector table pointer (TVTP)
 - definition A-7
- TRAPcond instruction 7-12, **14-267**
- traps 7-12, 7-24
 - initialization 7-24
 - operation 7-24
 - overlapping the TVT and IVT 7-25
 - vector table 7-25
- TSTB instruction **14-268**
- TSTB3 instruction 14-270
- TVTP 3-17
 - See also* trap vector table (TVT)

TVTP register 2-10
two parallel stores
 figure 8-22
two-operand instruction word 8-20
two-operand instructions
 table 14-4
type one synchronizer
 maximum delay 12-26
 minimum delay 12-26
type three synchronizer
 maximum delay 12-28
 minimum delay 12-27
type two synchronizer
 maximum delay 12-27
 minimum delay 12-27
TYPEx bit 3-14

U

UF flag 3-5
underflow 5-23
unified mode
 definition A-8
unified mode (DMA) 11-19, 11-35
unsigned-integer formats 5-3

V

V flag 3-5
value in a floating-point number
 equation 5-4
vector locations
 table 7-35
vectors (reset, interrupts) 7-28

W

wait state
 definition A-8
wait states 9-14, 9-36, 9-37
 bus disabled 9-38
wait-state generator
 definition A-8
word transfer
 operation 12-22, 12-23
word transfer sequence
 table 12-24

word transfers 11-5

write to AR 8-8

X

XOR instruction 14-272

XOR3 instruction 14-274

XOR3||STI instruction 14-276

Z

Z flag 3-5

zero fill

definition A-8