

AN-1496 Noise, TDMA Noise, and Suppression Techniques

ABSTRACT

The term “noise” is often and loosely used to describe unwanted electrical signals that distort the purity of the desired signal. Some forms of noise are unavoidable (e.g., real fluctuations in the quantity being measured), and they can be overcome only with the techniques of signal averaging and bandwidth narrowing. Other forms of noise (for example, radio frequency interference and “ground loops”) can be reduced or eliminated by a variety of techniques, including filtering and careful attention to wiring configuration and parts location. Finally, there is noise that arises in signal amplification and it can be reduced through the techniques of low-noise amplifier design. Although noise reduction techniques can be effective, it is prudent to begin with a system that is free of preventable interference and that possesses the lowest amplifier noise possible¹. This application note will specifically address the problem of TDMA Noise customers have encountered while driving mono speakers in their GSM phone designs.

Contents

| | | |
|---|----------------------------|---|
| 1 | Noise and TDMA Noise | 2 |
| 2 | Conclusion | 6 |
| 3 | References | 6 |
| 4 | Revision Table | 6 |

List of Figures

| | | |
|---|--|---|
| 1 | Bridge-Tied Load Mono Amplifier | 2 |
| 2 | Bridge-Tied Load Output Voltage | 3 |
| 3 | Periodic Transmitting and Receiving Current Pulse Waveform..... | 3 |
| 4 | RF Energy Coupling into the Audio Circuitry | 4 |
| 5 | External Two-pole Low-pass Filter Isolating the Amplifier Outputs..... | 5 |
| 6 | Measured TDMA Noise | 6 |

1 Noise and TDMA Noise

Following is a brief summary of different kinds of noise afflicting electronic circuits.

- Thermal Noise (or Johnson Noise or White Noise) is directly related to temperature manifested by the thermal agitation of electrons in resistors. In the case of loudspeakers and microphones, the source of noise is the thermal motion of the air molecules².
- Shot Noise is generated due to random fluctuation in the number of charged carriers when emitted from a surface or diffused from a junction. This noise is always associated with a direct current flow, independent of temperature, and is present in bipolar transistors².
- Flicker Noise (or 1/f Noise or Pink Noise) is caused mainly by traps associated with contamination and crystal defects. These traps capture and release carriers in a random fashion and the time constants associated with the process give rise to a noise signal with energy concentrated at low frequencies³.
- Burst Noise (Popcorn Noise) is generated by the presence of heavy metal ion contamination and is found in some integrated circuits and discrete transistors. With some bipolar integrated circuits, the popcorn noise was a result of too much doping of the emitter. Reducing the doping level made it possible to eliminate the popcorn noise test completely. This is another type of low-frequency noise³.
- Avalanche Noise is a form of noise produced by Zener or avalanche breakdown in a pn junction. In avalanche breakdown, holes and electrons in the depletion region of a reverse-biased pn junction acquire sufficient energy to create hole-electron pairs by colliding with silicon atoms³.
- TDMA Noise (“buzz”) in GSM mobile phones is generated from a 217Hz waveform which produces an audible noise when coupled into the audio path and conducts to the speaker, earpiece, or microphone⁴. Further details of this type of noise will follow.

Before delving into solutions that minimize the problem TDMA Noise customers have encountered while driving mono speakers in their GSM phone designs, some background describing the operations of a bridge-tied load (BTL) mono amplifier will be reviewed. In the following applicable figures, all resistors are of equal value, R (Figure 1).

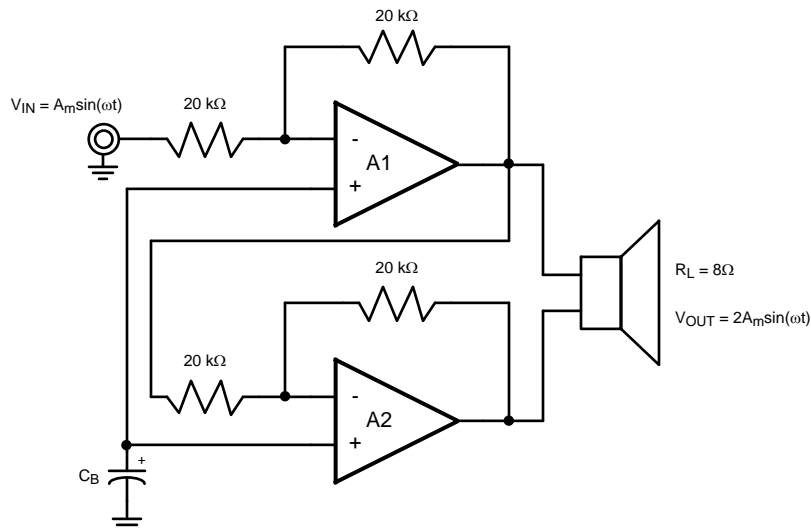

Figure 1. Bridge-Tied Load Mono Amplifier

In this configuration (Figure 1), an input signal V_{IN} is applied to the inverting input terminal of amplifier A1 and passes through with a gain of 0dB. The output of A1 is connected to one side of the loudspeaker and the inverting terminal of amplifier A2, which is also at a gain of 0dB. The output of A2 is connected to the other side of the loudspeaker. Since the output of A2 is 180° out of phase with the output of A1, the resulting difference between A1 and A2, V_{OUT} , has twice the magnitude of the individual amplifier outputs. When compared to a single-ended amplifier and a given sinusoidal input signal, this BTL configuration effectively doubles the output voltage and quadruples the output power with the same load (Figure 2).

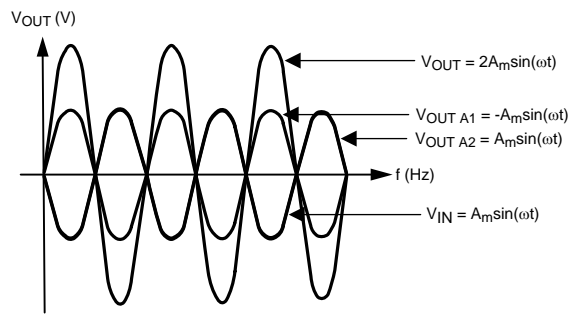

Figure 2. Bridge-Tied Load Output Voltage

As GSM phone manufacturers have discovered, the BTL mono configuration can be susceptible to radio frequency interference (RFI). Such unwanted signals are directly coupled into the audio path, distort the desired waveform, and may be audible as a “buzz”, known as TDMA Noise. GSM cell phones use a TDMA (time-division multiple-access) time-slot sharing technique that results in high-power RF in the 800MHz to 900MHz or 1800MHz to 1900MHz bands. The transmitter current, which can exceed 1A, pulses during a phone call at a repetition rate of 217Hz and pulse width of about 0.5ms. If current pulses couple to the audio circuitry, the harmonic-rich 217Hz signal results in the audible buzz⁴.

What is causing the audible buzz? Energy in the audio frequency range, including the 217Hz TDMA pulse-repetition rate and its harmonics, exists in the phone in two forms: as variations in the DC supply current and as the RF signal’s modulation envelope. The DC supply current pulse waveform comes from the large current that the RF power amplifier draws during transmission time slots and the smaller current that the RF circuitry draws during the receive interval (Figure 3).

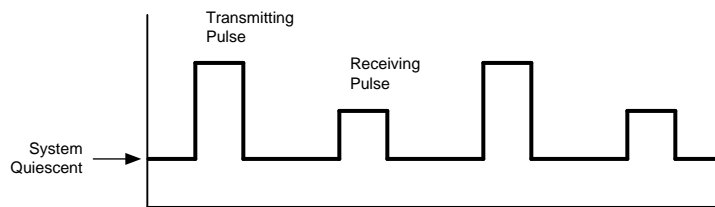

Figure 3. Periodic Transmitting and Receiving Current Pulse Waveform

The two primary mechanisms for coupling the current waveform into the audio circuits are supply and ground ripple, both at the 217Hz. Additionally, a portion of the transmitted RF energy can couple in the audio circuits⁴.

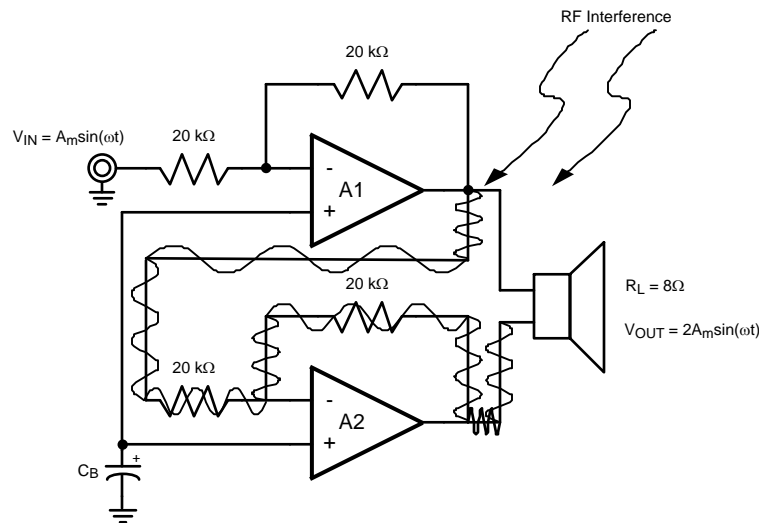

Figure 4. RF Energy Coupling into the Audio Circuitry

The potential for RF energy coupling into the audio circuit is most likely when there are long traces connecting the amplifier outputs to the loudspeaker, thereby acting as antennas (Figure 4). Good layout must also prevent RF energy from coupling into the audio and power traces that serve the baseband section or audio circuits within the phone. The design of these subsystems must block or bypass RF to ground so that it is not conducted to the semiconductor junctions of active audio components. RF energy can get from the RF circuitry to the audio circuitry through a variety of paths⁴:

- Radiation from the antenna to the audio or voltage supply components or to traces or components connected to them
- Conduction from RF components through traces to the audio components
- Conduction through ground to the audio subsystem
- Trace-to-trace coupling between lines or from a line to ground on the same or adjacent layers
- Coupling from line to component or component to component
- Prevention methods include shielding, ground design, and careful overall layout practice. Some preventive measures are as follows:
- Shield the audio section and its associated power-management and baseband sections to isolate them from stray RF. Shield the RF section to minimize the stray energy.
- Terminate the shield on a solid ground that is free of high dynamic currents.
- Isolate solid, largely unbroken audio ground on the layer below the audio sections from pulsing current.
- Do not allow traces onto same layer to bisect ground.
- Connect components to the ground layer through multiple vias.
- Do not route traces carrying power or audio signals parallel to those containing RF or large dynamic supply currents. Maximize the spacing between sensitive traces and potential sources of interference.
- For traces that must maintain perpendicular or (90°) design to minimize any noise coupling.
- Isolate audio traces on inner layers from non-audio traces by a ground trace with enough via holes to act as a Faraday shield.
- Do not place traces containing RF or dynamic DC currents directly under audio components.
- Place audio-feedback and signal-path components as close as possible to audio amplifiers, and isolate components from RF energy sources⁴.

Some RF energy will couple onto audio traces regardless of the effort to prevent this phenomenon from occurring. Utilizing bypass capacitors to ground to create single-pole low-pass filters will attenuate this energy from conducting into the audio amplifiers' semiconductor junctions. Small value capacitors must be used to bypass RF energy and not affect audio signals. Since GSM phone bands approximately inhabit the 900MHz and 1800MHz range, the best capacitors are those that are self-resonant at the aforementioned frequencies; typical capacitors of 10pF to 39pF have negligible effect on audio signals. Use each capacitor to shunt RF energy operating at each audio amplifier input, output, or power pin that is sensitive to RF energy.

For further isolation, add an inductor (or ferrite bead; the ferrite bead is a combined inductor and resistor) to form a two-pole low-pass filter, placing the components as close to the amplifier outputs as physically possible⁴. Figure 5 shows an actual application at the mono output of the LM4845. Experiencing an audio buzz at the mono loudspeaker, a customer implemented a two-pole low-pass filter with a -3dB cutoff frequency of 1MHz, well above the audio range and well below the GSM frequency bands. The audio buzz was attenuated by 30dB, an acceptable audible level to the customer.

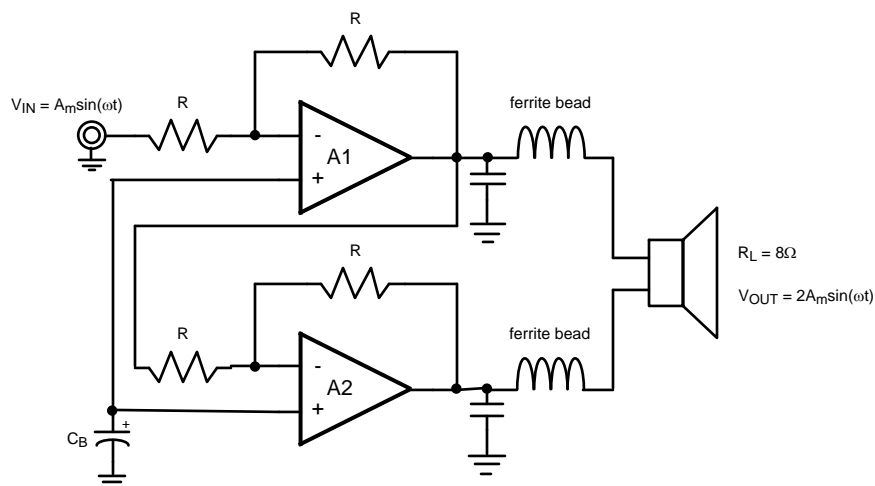

Figure 5. External Two-pole Low-pass Filter Isolating the Amplifier Outputs

Although one GSM cell phone manufacturer experienced TDMA noise while using the LM4845, other customers did not. After troubleshooting the customer's circuit, it was determined that poor part placement and poor layout was responsible for the audio buzz. To minimize noise susceptibility and aid system designers, the LM4845 was redesigned with differential mono inputs and a proprietary RF suppression circuit at the outputs of the amplifiers. This improved part is the LM4946. Figure 6 shows a comparison of the LM4845 and LM4946 under identical conditions.

Without the RF suppression circuitry, RF energy is propagated in the LM4845 and coupled into the audio path, with the 217Hz TDMA-pulse repetition carried on the RF modulation envelope. Although the same 217Hz TDMA-pulse repetition is still present in the LM4946, the RF suppression circuitry attenuates the RF energy 20dB to 30dB. Figure 6 also shows the modulation envelope in the LM4946 substantially attenuated.

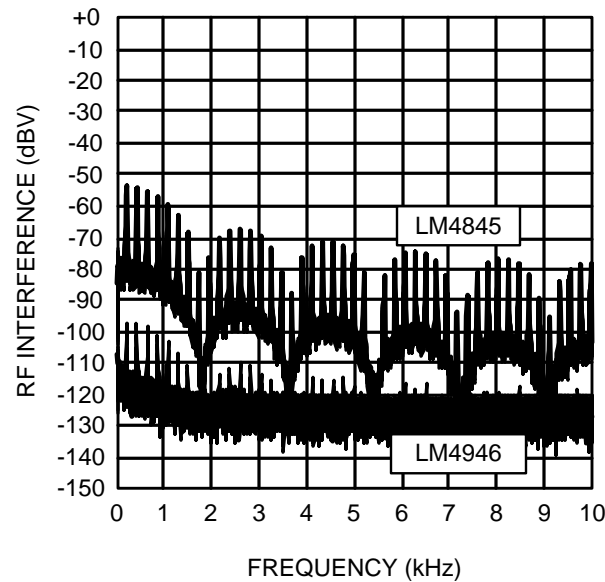

Figure 6. Measured TDMA Noise

To date, only the LM4884 and LM4946 contain the proprietary RF suppression circuits but further products are under development with this technology.

2 Conclusion

As the old adage goes, “an ounce of prevention is worth a pound of cure”; the same philosophy can be applied to GSM phone design. Trying to suppress TDMA noise after the design is costly, time consuming, and frustrating. Good prevention techniques must occur prior to the actual board layout: component placement, power supply trace locations, ground trace locations, shielding, and many more prevention techniques previously listed. The LM4946, LM4884, and future products with RF suppression can substantially minimize TDMA noise problems, but no single solution can prevent TDMA noise from occurring.

Note: In this application note the terms “TDMA noise”, “RF energy”, “audio buzz”, and “buzz” are used interchangeably.

3 References

1. P. Horowitz, W. Winfield. *The Art of Electronics*, Cambridge University Press, New York, 1999, Chapter 7
2. M. Rashid. *SPICE For Circuits And Electronics Using PSpice*, Prentice Hall, New Jersey, 1990, Appendix B
3. P. Gray, P. Hurst, S. Lewis, and R. Meyer. *Analysis and Design of Analog Integrated Circuits*, John Wiley & Sons, New York, 2001, Chapter 11
4. B. Poole. “Reducing Audio ‘Buzz’ in GSM Cell Phones”, *EDN*, pp. 67 – 70, February 2005

4 Revision Table

| Rev | Date | Description |
|-----|----------|---------------------------------------|
| 1.0 | 05/24/06 | Initial release. |
| 1.1 | 10/01/07 | Corrected a misspelled word. |
| 1.2 | 04/28/08 | Edited graphics 20197019, 20, and 21. |

IMPORTANT NOTICE

Texas Instruments Incorporated and its subsidiaries (TI) reserve the right to make corrections, enhancements, improvements and other changes to its semiconductor products and services per JESD46, latest issue, and to discontinue any product or service per JESD48, latest issue. Buyers should obtain the latest relevant information before placing orders and should verify that such information is current and complete. All semiconductor products (also referred to herein as "components") are sold subject to TI's terms and conditions of sale supplied at the time of order acknowledgment.

TI warrants performance of its components to the specifications applicable at the time of sale, in accordance with the warranty in TI's terms and conditions of sale of semiconductor products. Testing and other quality control techniques are used to the extent TI deems necessary to support this warranty. Except where mandated by applicable law, testing of all parameters of each component is not necessarily performed.

TI assumes no liability for applications assistance or the design of Buyers' products. Buyers are responsible for their products and applications using TI components. To minimize the risks associated with Buyers' products and applications, Buyers should provide adequate design and operating safeguards.

TI does not warrant or represent that any license, either express or implied, is granted under any patent right, copyright, mask work right, or other intellectual property right relating to any combination, machine, or process in which TI components or services are used. Information published by TI regarding third-party products or services does not constitute a license to use such products or services or a warranty or endorsement thereof. Use of such information may require a license from a third party under the patents or other intellectual property of the third party, or a license from TI under the patents or other intellectual property of TI.

Reproduction of significant portions of TI information in TI data books or data sheets is permissible only if reproduction is without alteration and is accompanied by all associated warranties, conditions, limitations, and notices. TI is not responsible or liable for such altered documentation. Information of third parties may be subject to additional restrictions.

Resale of TI components or services with statements different from or beyond the parameters stated by TI for that component or service voids all express and any implied warranties for the associated TI component or service and is an unfair and deceptive business practice. TI is not responsible or liable for any such statements.

Buyer acknowledges and agrees that it is solely responsible for compliance with all legal, regulatory and safety-related requirements concerning its products, and any use of TI components in its applications, notwithstanding any applications-related information or support that may be provided by TI. Buyer represents and agrees that it has all the necessary expertise to create and implement safeguards which anticipate dangerous consequences of failures, monitor failures and their consequences, lessen the likelihood of failures that might cause harm and take appropriate remedial actions. Buyer will fully indemnify TI and its representatives against any damages arising out of the use of any TI components in safety-critical applications.

In some cases, TI components may be promoted specifically to facilitate safety-related applications. With such components, TI's goal is to help enable customers to design and create their own end-product solutions that meet applicable functional safety standards and requirements. Nonetheless, such components are subject to these terms.

No TI components are authorized for use in FDA Class III (or similar life-critical medical equipment) unless authorized officers of the parties have executed a special agreement specifically governing such use.

Only those TI components which TI has specifically designated as military grade or "enhanced plastic" are designed and intended for use in military/aerospace applications or environments. Buyer acknowledges and agrees that any military or aerospace use of TI components which have **not** been so designated is solely at the Buyer's risk, and that Buyer is solely responsible for compliance with all legal and regulatory requirements in connection with such use.

TI has specifically designated certain components as meeting ISO/TS16949 requirements, mainly for automotive use. In any case of use of non-designated products, TI will not be responsible for any failure to meet ISO/TS16949.

Products

| | |
|------------------------------|--|
| Audio | www.ti.com/audio |
| Amplifiers | amplifier.ti.com |
| Data Converters | dataconverter.ti.com |
| DLP® Products | www.dlp.com |
| DSP | dsp.ti.com |
| Clocks and Timers | www.ti.com/clocks |
| Interface | interface.ti.com |
| Logic | logic.ti.com |
| Power Mgmt | power.ti.com |
| Microcontrollers | microcontroller.ti.com |
| RFID | www.ti-rfid.com |
| OMAP Applications Processors | www.ti.com/omap |
| Wireless Connectivity | www.ti.com/wirelessconnectivity |

Applications

| | |
|-------------------------------|--|
| Automotive and Transportation | www.ti.com/automotive |
| Communications and Telecom | www.ti.com/communications |
| Computers and Peripherals | www.ti.com/computers |
| Consumer Electronics | www.ti.com/consumer-apps |
| Energy and Lighting | www.ti.com/energy |
| Industrial | www.ti.com/industrial |
| Medical | www.ti.com/medical |
| Security | www.ti.com/security |
| Space, Avionics and Defense | www.ti.com/space-avionics-defense |
| Video and Imaging | www.ti.com/video |

TI E2E Community

e2e.ti.com