



National
Qualifications
2018

2018 Practical Electronics

National 5

Finalised Marking Instructions

© Scottish Qualifications Authority 2018

The information in this publication may be reproduced to support SQA qualifications only on a non-commercial basis. If it is reproduced, SQA should be clearly acknowledged as the source. If it is to be used for any other purpose, written permission must be obtained from permissions@sqa.org.uk.

Where the publication includes materials from sources other than SQA (secondary copyright), this material should only be reproduced for the purposes of examination or assessment. If it needs to be reproduced for any other purpose it is the centre's responsibility to obtain the necessary copyright clearance. SQA's NQ Assessment team may be able to direct you to the secondary sources.

These marking instructions have been prepared by examination teams for use by SQA appointed markers when marking external course assessments. This publication must not be reproduced for commercial or trade purposes.



General marking principles for National 5 Practical Electronics

This information is provided to help you understand the general principles you must apply when marking candidate responses to questions in this paper. These principles must be read in conjunction with the detailed marking instructions, which identify the key features required in candidate responses.

- (a) Marks for each candidate response must **always** be assigned in line with these general marking principles and the detailed marking instructions (MIs) for this assessment.
- (b) Marking should always be positive. This means that, for each candidate response, marks are accumulated for the demonstration of relevant skills, knowledge and understanding: they are not deducted from a maximum on the basis of errors or omissions.
- (c) If a specific candidate response does not seem to be covered by either the principles or detailed marking instructions, and you are uncertain how to assess it, you must seek guidance from your team leader.

When marking National 5 Practical Electronics, there are some common issues which arise when considering candidates' answers.

There is often a range of acceptable answers which would sensibly answer a particular question. However, it is often difficult to anticipate all correct or partially correct responses to questions. The answers given in the MIs represent ideal answers.

Additional acceptable answers are also given in the MIs to offer guidance to assist interpreting candidates' answers.

Also, advice on answers which are NOT acceptable or only attract partial marks may also be given in the MIs for some questions.

Markers are reminded that marks for each candidate response must always be assigned in accordance with the general marking principles and the specific marking instructions for the relevant question.

- (d) There are **no half marks** awarded.
- (e) **In calculations**, marks should be awarded for non-standard symbols where the symbols are defined and the relationship is correct, or where the substitution shows that the relationship used is correct. This must be clear and unambiguous.
- (f) Unless a numerical question specifically requires evidence of working to be shown, full marks should be awarded for a correct final answer (including units if required) on its own.
- (g) Marks are provided for knowledge of relevant formulae alone. When a candidate writes down several formulae and does not select the correct one to continue with, for example by substituting values, no mark can be awarded.
- (h) Where a wrong answer to part of a question is carried forward and the wrong answer is then used correctly in the following part, the candidate should be given credit for the subsequent part or 'follow on'.
- (i) Rounding to an expected number of significant figures, the mark can be awarded for answers which have up to two figures more or one figure less than the number in the data with the fewest significant figures. (Note: the use of a recurrence dot, eg $\bar{3}$, would imply an infinite number of significant figures and would therefore not be acceptable.)
- (j) Where a question asks for or requires a specific number of reasons, examples, points, etc and the candidate provides more than the required number of responses then each incorrect response negates a correct response.

- (k) Marks are awarded only for a valid response to the question asked. For example, in response to questions that ask candidates to:
- **identify, name, give, or state**, they need only name or present in brief form;
 - **draw**, they must provide or complete a drawing, eg a circuit diagram, layout diagram or logic diagram;
 - **complete**, they must complete the response, eg completing a truth table, layout diagram, checklist, etc;
 - **describe**, they must provide a statement or structure of characteristics and/or features;
 - **explain**, they must relate cause and effect and/or make relationships between things clear;
 - **determine or calculate**, they must determine a number from given facts, figures or information;
 - **estimate**, they must determine an approximate value for something;
 - **justify**, they must give reasons to support their suggestions or conclusions, eg this might be by identifying an appropriate relationship and the effect of changing variables;
 - **show that**, they must use electronics (and mathematics) to prove something, eg a given value – *all steps, including the stated answer, must be shown*;
 - **predict**, they must suggest what may happen based on available information;
 - **suggest**, they must apply their knowledge and understanding of electronics to a new situation. A number of responses are acceptable: marks will be awarded for any suggestions that are supported by knowledge and understanding of electronics.

Common issues with candidate responses:

Spelling

The incorrect spelling of technical terms should be ignored and candidates should be awarded the relevant mark. If answers can be interpreted and understood without any doubt as to the meaning, then the answer should be marked according to the MIs.

However, care should be taken to ensure that the incorrect spelling does not make the response ambiguous, leading to possible 'wrong electronics'. For example 'use a smaller resistor' instead of 'use a smaller resistance' is ambiguous, since a smaller resistor may not have a smaller resistance.

If the spelling (or handwriting) in an answer makes it difficult for you to interpret a candidate's intention, then do not award the mark.

Units

Use of R notation is acceptable eg 270R, 4k7, 6M8, etc.

For **numerical** and **non-numerical** answers which require a unit to be **stated** in an answer, the incorrect spelling of the unit is not usually penalised (if the unit can be clearly identified).

eg 'State the unit of capacitance.' Answer: 'farad'. The answer: 'farrads' would be acceptable.

Also for **numerical** and **non-numerical** answers, do not penalise upper/lower casing when the abbreviated version is given eg v, f, hZ.

Ohms (Ω) is an exception, ω would not be an acceptable abbreviation.

However, for **numerical answers**, care must be taken to ensure the unit has the correct prefix, eg for an answer $t = 0.005$ seconds, $t = 5$ ms is acceptable but NOT $t = 5$ Ms.

Some common units often attract wrong abbreviations in answers to numerical questions. When the abbreviation can be confused with a different unit then this would attract a unit penalty, eg sec or secs as an abbreviation for seconds is NOT acceptable.

Standard form:

Candidates may fail to express an answer in standard form correctly.

For an answer $t = 400\,000\text{ s}$, then $t = 4 \times 10^5\text{ s}$ would be correct but $t = 4^5\text{ s}$ would be treated as an arithmetic error and the final mark would not be awarded.

Relationship (equation) selection:

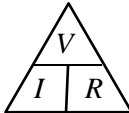
No marks should be awarded if a 'magic triangle', eg , was the only statement in a candidate's response.

The correct relationship must be stated, eg $V = IR$ or $R = \frac{V}{I}$, to gain (1) mark.

Incorrect answer carried forward:

Where an incorrect answer to a part of a question is carried forward

- within that part of the question, eg (a)(i) and (a)(ii)
- to the next part of the question, eg (a) and (b)

this should incur no further penalty, provided that it is used correctly.

Where a question requires a data value and the candidate has selected the wrong value, then either the candidate's wrong value may be used OR the correct data value in the subsequent answer and the response could gain full marks if correctly completed.

Example:

(a) State the tolerance in the resistance of a resistor with a gold tolerance band.

Candidate's answer: 2%. This answer would attract zero marks.

(b) Calculate the maximum and minimum possible resistances of the resistor.

Candidate may use either the value given in part (a) OR the correct value for the tolerance and could gain full marks if correctly completed.

The 'Additional guidance' column of the MIs would indicate the comment 'or consistent with part...' to indicate that an incorrect answer may be carried forward.

Standard three marker:

The examples below set out how to apportion marks to answers requiring calculations. These are the 'standard three marker' type of questions.

Unless a numerical question specifically requires evidence of working to be shown, full marks should be given for a correct answer to a numerical question even if the steps are not shown explicitly. The individual marks shown below are for use when marking partially correct answers.

Markers who are new to marking SQA Practical Electronics exams should study these issues closely, since the guidance illustrates common faults in candidates' answers to the 'standard three marker' type of question. Items 1-15 below illustrate how to apportion marks accordingly.

Experienced markers should also re-acquaint themselves with these examples before marking.

For some questions requiring numerical calculations, there may be alternative methods (eg alternative relationships) which would lead to a correct answer. These alternative methods of reaching the answer and how to apportion marks are also included in the specific MIs for these questions.

Sometimes, a question requires a calculation which does not fit into the 'standard three marker' type of response. Full guidance on how to apportion marks will be given in the MIs for that specific question.

Question:

The current in a resistor is 1.5 amperes when the potential difference across it is 7.5 volts. Calculate the resistance of the resistor. (3 marks)

Candidate answer	Mark + Comment
1. $V = IR$ $7.5 = 1.5R$ $R = 5.0 \Omega$	1 mark: formula 1 mark: substitution 1 mark: correct answer
2. 5.0Ω	3 marks: correct answer
3. 5.0	2 marks: unit missing
4. 4.0Ω	0 marks: no evidence, wrong answer
5. $__ \Omega$	0 marks: no working or final answer
6. $R = \frac{V}{I} = \frac{7.5}{1.5} = 4.0 \Omega$	2 marks: arithmetic error
7. $R = \frac{V}{I} = 4.0 \Omega$	1 mark: formula only
8. $R = \frac{V}{I} = __ \Omega$	1 mark: formula only
9. $R = \frac{V}{I} = \frac{7.5}{1.5} = __ \Omega$	2 marks: formula and substitution, no final answer
10. $R = \frac{V}{I} = \frac{7.5}{1.5} = 4.0$	2 marks: formula and substitution, wrong answer
11. $R = \frac{V}{I} = \frac{1.5}{7.5} = 5.0 \Omega$	1 mark: formula but wrong substitution
12. $R = \frac{V}{I} = \frac{75}{1.5} = 5.0 \Omega$	1 mark: formula but wrong substitution
13. $R = \frac{I}{V} = \frac{1.5}{7.5} = 5.0 \Omega$	0 marks: wrong formula
14. $V = IR$ $7.5 = 1.5 \times R$ $R = 0.2 \Omega$	2 marks: formula and substitution, arithmetic error
15. $V = IR$ $R = \frac{I}{V} = \frac{1.5}{7.5} = 0.2 \Omega$	1 mark: formula correct but wrong rearrangement of symbols

Marking instructions for each question

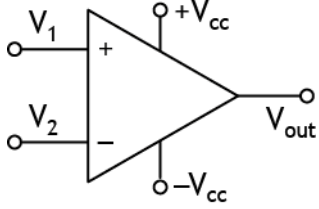
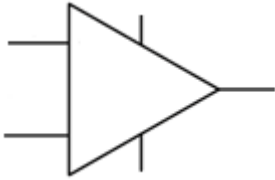
Question		Expected response	Max mark	Additional guidance
1.	(a)	<p>Light emitting diode/LED (1 mark)</p> <p>Electromagnetic switch (1 mark)</p>  <p>(1 mark)</p>	3	<p>Relay- explains control of high power/current/voltage circuit via a low power/current/voltage circuit.</p> <p>Minimum acceptable 741 diagram</p> 
	(b)	(i) 12 000 Ω/ 12 kΩ / 12K	1	
		(ii) (±) 1 (%)	1	
		(iii) Blue and grey (1 mark) Red (1 mark)	2	1 mark for first and second bands correct. 1 mark for multiplier.
2.		Multi-strand: phone/telecom (1 mark) Coaxial: aerial/TV signal/radio signals/connecting CRO/audio (1 mark)	2	Accept any sensible suggestions.



Question		Expected response	Max mark	Additional guidance
3.	(a)	$V = IR$ (1 mark) $8 = 0.5 \times R$ (1 mark) $R = 16 \Omega$ (1 mark)	3	Accept 16R
	(b)	$\frac{1}{R_T} = \frac{1}{R_1} + \frac{1}{R_2}$ (1 mark) $\frac{1}{R_T} = \frac{1}{24} + \frac{1}{12}$ (1 mark) $R_T = 8 \Omega$ (1 mark)	3	$R_T = \frac{R_1 R_2}{R_1 + R_2}$ is an acceptable alternative method. If wrong equation used, eg $R_T = \frac{1}{\frac{1}{R_1} + \frac{1}{R_2}}$ then (0) marks. Accept imprecise working towards a final answer. $\frac{1}{R_T} = \frac{1}{R_1} + \frac{1}{R_2} = \frac{1}{12} + \frac{1}{24} = 8 \Omega$ <div style="text-align: center;"> ↑ accept </div> Accept 8R
	(c)	$R_3 = 8 \Omega$	1	Or consistent with (a) and (b). Accept 8R
	(d)	$V_3 = 4 \text{ V}$	1	Or consistent with (a), (b), and (c).
	(e)	$P = \frac{V^2}{R}$ (1 mark) $P = \frac{4^2}{8}$ (1 mark) $P = 2 \text{ W}$ (1 mark)	3	Or consistent with (a), (b), (c), and (d). $P = IV$ 1 $P = 0.5 \times 4$ 1 $P = 2 \text{ W}$ 1 Or $P = I^2 R$ 1 $P = 0.5^2 \times 8$ 1 $P = 2 \text{ W}$ 1

Question		Expected response	Max mark	Additional guidance																																																						
4.	(a)	<table border="1"> <thead> <tr> <th>A</th> <th>B</th> <th>Output</th> </tr> </thead> <tbody> <tr> <td>0</td> <td>0</td> <td>0</td> </tr> <tr> <td>0</td> <td>1</td> <td>1</td> </tr> <tr> <td>1</td> <td>0</td> <td>1</td> </tr> <tr> <td>1</td> <td>1</td> <td>1</td> </tr> </tbody> </table>	A	B	Output	0	0	0	0	1	1	1	0	1	1	1	1	1																																								
A	B	Output																																																								
0	0	0																																																								
0	1	1																																																								
1	0	1																																																								
1	1	1																																																								
	(b)	Exclusive OR / XOR	1																																																							
	(c)	7400 (quad 2 input NAND gates) OR Quad 2 input NAND (gates)	1	Do not accept NAND on its own.																																																						
	(d)	<table border="1"> <thead> <tr> <th>A</th> <th>B</th> <th>C</th> <th>X</th> <th>Y</th> <th>Z</th> </tr> </thead> <tbody> <tr> <td>0</td> <td>0</td> <td>0</td> <td>1</td> <td>1</td> <td>0</td> </tr> <tr> <td>0</td> <td>0</td> <td>1</td> <td>1</td> <td>0</td> <td>1</td> </tr> <tr> <td>0</td> <td>1</td> <td>0</td> <td>1</td> <td>1</td> <td>0</td> </tr> <tr> <td>0</td> <td>1</td> <td>1</td> <td>1</td> <td>0</td> <td>1</td> </tr> <tr> <td>1</td> <td>0</td> <td>0</td> <td>1</td> <td>1</td> <td>0</td> </tr> <tr> <td>1</td> <td>0</td> <td>1</td> <td>1</td> <td>0</td> <td>1</td> </tr> <tr> <td>1</td> <td>1</td> <td>0</td> <td>0</td> <td>1</td> <td>0</td> </tr> <tr> <td>1</td> <td>1</td> <td>1</td> <td>0</td> <td>1</td> <td>0</td> </tr> </tbody> </table>	A	B	C	X	Y	Z	0	0	0	1	1	0	0	0	1	1	0	1	0	1	0	1	1	0	0	1	1	1	0	1	1	0	0	1	1	0	1	0	1	1	0	1	1	1	0	0	1	0	1	1	1	0	1	0	3	1 mark for each column. Apply follow through between columns.
A	B	C	X	Y	Z																																																					
0	0	0	1	1	0																																																					
0	0	1	1	0	1																																																					
0	1	0	1	1	0																																																					
0	1	1	1	0	1																																																					
1	0	0	1	1	0																																																					
1	0	1	1	0	1																																																					
1	1	0	0	1	0																																																					
1	1	1	0	1	0																																																					
5.		<p>Connect red wire of probe to V_{supply} and black wire to 0 V or equivalent. (1 mark)</p> <p>Place the probe tip onto circuit at selected point. (1 mark)</p> <p>Red LED lights. (1 mark)</p>	3	Do not accept: connect the probe to the supply rails (on its own). 3 independent marks																																																						

Question		Expected response	Max mark	Additional guidance
6.	(a)	$T = (4 \times 10 \text{ ms}) = 40 \text{ ms}$ (1 mark)	3	<p>If incorrect setting chosen from oscilloscope award a maximum of 1 mark for the formula.</p> <p>If period incorrect then award a maximum of 1 mark for the formula.</p> <p>If milli omitted from the period of the wave, treat as a unit error and award a maximum of 2 marks, unless final answer is then quoted as 0.025 kHz, in which case 3 marks may be awarded.</p>
		$f = \frac{1}{T}$ (1 mark)		
		$f = 25 \text{ Hz}$ (1 mark)		
	(b)	Trace should have double the amplitude (with 3 peaks and two troughs).	1	
7.	(a)	(i) 20 lux	1	
		(ii) Drop voltage/reduce current/protect LED/limit power.	1	Do not accept: voltage 'through' or current 'across' on their own.
		(iii) Switch on voltage too high/2 V.	1	
	(b)	$V_2 = \frac{R_2}{R_1 + R_2} \times V_s$ (1 mark) $V_2 = \frac{2400}{600 + 2400} \times 1.5$ (1 mark) $V_2 = 1.2 \text{ V}$ (1 mark)	3	$V = IR$ $1.5 = I \times 3000$ $I = 5 \times 10^{-4} \text{ (A)}$ $V = IR$ $V = 5 \times 10^{-4} \times 2400$ $V = 1.2 \text{ V}$ <p>1 mark for Ohm's Law anywhere. 1 mark for both substitutions. 1 mark for final answer including unit.</p> <p>Or by voltage ratio method.</p> <p>If correct answer given with no working award 3 marks.</p>

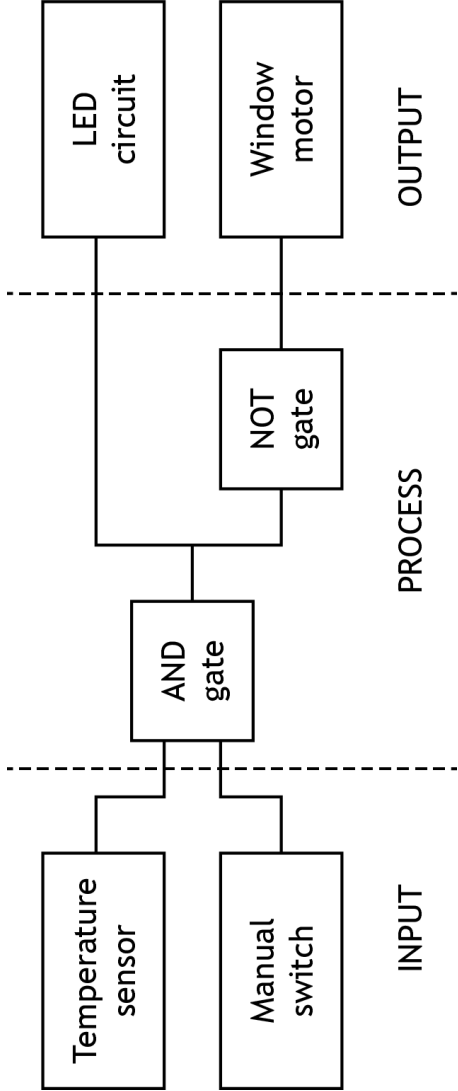
Question		Expected response		Max mark	Additional guidance																																
8.		Power supply reversed/ wrong way round. (1 mark) LD ₂ wrong polarity/wrong way round. (1 mark) C ₂ value incorrect/too big/ different. (1 mark) R ₂ / R ₃ value incorrect/ different. (1 mark)		4	Errors can be listed in any order. Battery not accepted																																
9.		<table border="1"> <thead> <tr> <th>Supplier</th> <th>Component</th> <th>Product code</th> <th>Cost (p)</th> </tr> </thead> <tbody> <tr> <td>JIMSON</td> <td>NE555</td> <td>TC124</td> <td>20</td> </tr> <tr> <td>SWIFT</td> <td>8 way DIL socket</td> <td>SK-0080</td> <td>10</td> </tr> <tr> <td>SWIFT</td> <td>LED 5mm std</td> <td>SC-0155</td> <td>4</td> </tr> <tr> <td>JIMSON</td> <td>47µF electrolytic capacitor</td> <td>EC799</td> <td>14</td> </tr> <tr> <td>JIMSON</td> <td>270R</td> <td>FR922</td> <td>0.25</td> </tr> <tr> <td>JIMSON</td> <td>1K</td> <td>FR923</td> <td>0.25</td> </tr> <tr> <td>SWIFT</td> <td>10K</td> <td>EC-0182</td> <td>1.5</td> </tr> </tbody> </table>	Supplier	Component	Product code	Cost (p)	JIMSON	NE555	TC124	20	SWIFT	8 way DIL socket	SK-0080	10	SWIFT	LED 5mm std	SC-0155	4	JIMSON	47µF electrolytic capacitor	EC799	14	JIMSON	270R	FR922	0.25	JIMSON	1K	FR923	0.25	SWIFT	10K	EC-0182	1.5		5	1 mark for each correct row.
Supplier	Component	Product code	Cost (p)																																		
JIMSON	NE555	TC124	20																																		
SWIFT	8 way DIL socket	SK-0080	10																																		
SWIFT	LED 5mm std	SC-0155	4																																		
JIMSON	47µF electrolytic capacitor	EC799	14																																		
JIMSON	270R	FR922	0.25																																		
JIMSON	1K	FR923	0.25																																		
SWIFT	10K	EC-0182	1.5																																		

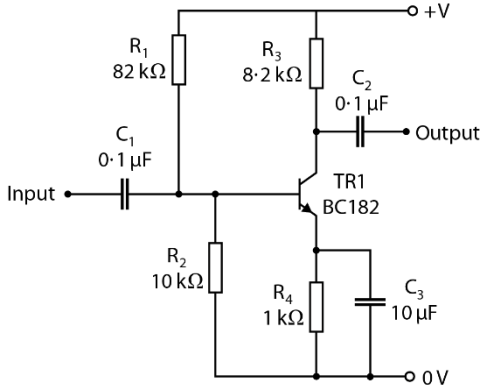
Question	Expected response	Max mark	Additional guidance
10.	<p>1 mark for selecting both input devices.</p> <p>1 mark for selecting correct gates.</p> <p>1 mark for selecting both output devices.</p> <p>1 mark for correctly linking the inputs to gates.</p> <p>1 mark for correctly linking the outputs to the gates.</p> <p>1 mark for correctly identifying the three sections of the system diagram.</p> 	6	<p>All selected elements must be shown as part of a system/block diagram.</p> <p>(arrows are NOT required on the connections).</p>

Question	Expected response	Max mark	Additional guidance
11.	<p>1 mark for both power rails.</p> <p>1 mark for transistor oriented in a functional manner and uses correct symbol.</p> <p>1 mark for the four resistors (with correct symbol) relative to power rails and transistor.</p> <p>1 mark for C3 in parallel to R4 and uses acceptable symbol.</p> <p>1 mark for placement of input and C1(with correct symbol) relative to transistor.</p> <p>1 mark for placement of C2 (with correct symbol) and output relative to transistor.</p> 	6	<p>Component symbols must be used.</p> <p>Accept electrolytic capacitor symbols.</p> <p>Each component must be identifiable. Accept a mixture of component values and identifiers.</p> <p>(accept R notation)</p> <p>Node spot for input/outputs are not required.</p> <p>Power rails must have</p> <p>V+ or Vs and 0V with  end node.</p>

[END OF MARKING INSTRUCTIONS]