

# SAP Backup using Tivoli Storage Manager

Covers and compares data management techniques for SAP

Presents a sample implementation of DB2 and Oracle databases

Explains LAN-free and FlashCopy techniques

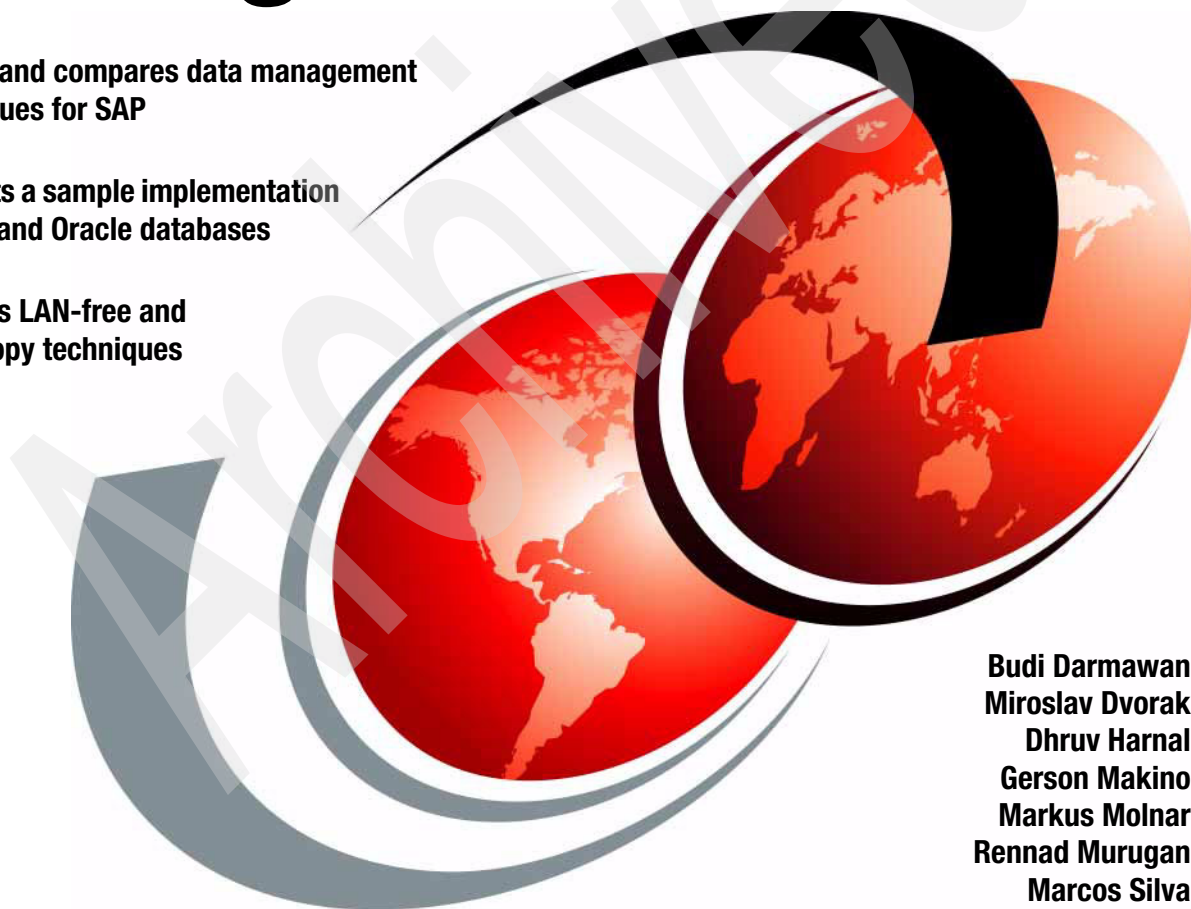

Budi Darmawan  
Miroslav Dvorak  
Dhruv Harnal  
Gerson Makino  
Markus Molnar  
Rennad Murugan  
Marcos Silva





International Technical Support Organization

**SAP Backup using Tivoli Storage Manager**

June 2009

Archived

**Note:** Before using this information and the product it supports, read the information in “Notices” on page xi.

### **First Edition (June 2009)**

This edition applies to Version 5, Release 5, Modification 0 of Tivoli Storage Manager and its related components:

- ▶ Tivoli Storage Manager Server, 5608-ISM
- ▶ Tivoli Storage Manager for Enterprise Resource Planning, 5608-APR
- ▶ Tivoli Storage Manager for Databases, 5608-APD
- ▶ Tivoli Storage Manager for Advanced Copy Services, 5608-ACS
- ▶ Tivoli Storage Manager for SAN, 5608-SAN

© Copyright International Business Machines Corporation 2009. All rights reserved.

Note to U.S. Government Users Restricted Rights -- Use, duplication or disclosure restricted by GSA ADP Schedule Contract with IBM Corp.

# Contents

<b>Notices</b> .....	.xi
Trademarks .....	xii
<b>Preface</b> .....	xv
The team that wrote this book .....	xv
Become a published author .....	xvii
Comments welcome .....	xviii
<b>Part 1. Concepts</b> .....	1
<b>Chapter 1. SAP data management</b> .....	3
1.1 SAP .....	4
1.2 Data management .....	4
1.3 Book structure .....	5
<b>Chapter 2. SAP overview</b> .....	7
2.1 SAP product history .....	8
2.2 SAP solutions and products .....	11
2.2.1 Enterprise solutions .....	11
2.2.2 Business solutions .....	13
2.2.3 SAP solutions for small businesses and mid-size companies .....	13
2.3 SAP NetWeaver overview .....	13
2.3.1 Key capabilities .....	14
2.3.2 Database positioning .....	17
2.3.3 Application platform in detail .....	18
2.4 SAP architecture .....	23
2.4.1 Technical components .....	24
2.4.2 Central instance .....	26
2.4.3 Central services instance .....	27
2.4.4 Database instance .....	27
2.4.5 Dialog instance .....	27
2.5 SAP system topologies .....	28
2.6 Change and Transport System .....	30
2.6.1 Clients and their roles .....	31
2.6.2 System landscape .....	32
2.6.3 Change management in the SAP system landscape .....	34
2.7 SAP database .....	35
2.7.1 Supported databases .....	35
2.7.2 Database administration facilities .....	35

2.7.3 Connectivity and integration .....	36
2.8 References .....	39
<b>Chapter 3. SAP data protection considerations .....</b>	<b>41</b>
3.1 Strategic view of data protection .....	42
3.1.1 Measuring data availability and protection service levels .....	44
3.1.2 Failure types .....	47
3.2 Protection of SAP data .....	49
3.2.1 Protection of the operating system .....	51
3.2.2 Protection of SAP file systems data .....	51
3.2.3 Protection of the SAP database .....	53
3.2.4 Include exclude options. ....	59
3.3 Database backup types and considerations .....	61
3.3.1 Backup modes .....	61
3.3.2 Backup types. ....	63
3.3.3 Backup cycles .....	65
3.3.4 Backup policy .....	66
3.3.5 Retention period and tape release .....	67
3.4 Data protection and data retention .....	68
3.5 Tivoli Storage Manager and the SAP landscape .....	69
3.5.1 Centralized SAP system .....	70
3.5.2 Distributed SAP system .....	70
3.5.3 High availability SAP system. ....	72
3.6 High availability .....	76
3.6.1 Availability and performance. ....	76
3.6.2 High availability related consideration. ....	78
3.6.3 Disaster recovery .....	81
3.7 Backup scheduling considerations .....	82
3.7.1 SAP scheduler .....	82
3.7.2 Tivoli Storage Manager scheduling. ....	85
3.7.3 Operating system schedulers .....	86
3.7.4 External workload scheduling tools. ....	87
<b>Chapter 4. Introduction to IBM Tivoli Storage Manager .....</b>	<b>89</b>
4.1 IBM Tivoli Storage Manager .....	90
4.1.1 IBM Tivoli Storage Manager overview .....	90
4.1.2 IBM Tivoli Storage Manager architecture .....	92
4.1.3 IBM Tivoli Storage Manager server. ....	94
4.1.4 IBM Tivoli Storage Manager backup/archive client. ....	95
4.1.5 Tivoli Storage Manager backup .....	96
4.2 IBM Tivoli Storage Manager storage agent. ....	97
4.3 Tivoli Storage Manager for Enterprise Resource Planning .....	97
4.3.1 Integration of Data Protection for SAP with SAP .....	98

4.3.2	Data Protection for SAP for Oracle database	99
4.3.3	Tivoli Data Protection for SAP for DB2	104
4.4	Tivoli Storage Manager for Databases	105
4.4.1	Tivoli Data Protection for Oracle	105
4.4.2	Tivoli Data Protection for Microsoft SQL Server	105
4.5	ADINT/TSM client for MaxDB	106
4.6	Tivoli Storage Manager for Advanced Copy Services	107
4.6.1	Supported storage hardware	108
4.6.2	Introduction to copy services	109
4.6.3	Tivoli Storage Manager for Advanced Copy Services on SAP	111
<b>Chapter 5. IBM DB2 CommonStore for SAP</b>		<b>115</b>
5.1	CommonStore for SAP overview	116
5.2	Scenarios and features	119
5.2.1	Data archiving	119
5.2.2	Document archiving	120
5.3	CommonStore for SAP server prerequisites	121
5.4	CommonStore clients	122
5.4.1	CommonStore archiving client	123
5.4.2	CommonStore Viewing Client	124
5.4.3	CommonStore Utility Client	125
5.5	References	126
<b>Chapter 6. Database backup and recovery tools</b>		<b>127</b>
6.1	Database backup and recovery tools	128
6.2	SAP BR*Tools for Oracle	133
6.2.1	User interfaces	134
6.2.2	Backup control function	134
6.2.3	Archived redo log backup functions	136
6.2.4	Restore and recovery functions	137
6.2.5	Media interfaces	139
6.2.6	Backup repository	140
6.2.7	BR*Tools and Tivoli Storage Manager for ERP - Oracle	140
6.2.8	References	145
6.3	Oracle Recovery Manager (RMAN)	145
6.3.1	User interfaces	146
6.3.2	Backup control functions	147
6.3.3	Archive redo log backup functions	148
6.3.4	Restore and recovery functions	149
6.3.5	Media interfaces	151
6.3.6	Backup repository and retention control	152
6.3.7	Integration of BR*Tools with Oracle RMAN	153
6.3.8	References	156

6.4 IBM DB2 UDB backup recovery tools . . . . .	157
6.4.1 User interfaces . . . . .	157
6.4.2 Backup control functions . . . . .	158
6.4.3 Archived redo log backup functions . . . . .	160
6.4.4 Restore and recovery functions . . . . .	162
6.4.5 Media interfaces . . . . .	163
6.4.6 Backup repository . . . . .	163
6.4.7 DB2 UDB built-in Tivoli Storage Manager support . . . . .	164
6.4.8 DB2 UDB with Tivoli Storage Manager for ERP (DB2) . . . . .	166
6.4.9 References . . . . .	172
6.5 SAP MaxDB backup recovery tools . . . . .	172
6.5.1 User interfaces . . . . .	173
6.5.2 Backup control functions . . . . .	174
6.5.3 Archived redo log backup functions . . . . .	175
6.5.4 Restore and recovery functions . . . . .	175
6.5.5 Media interfaces . . . . .	177
6.5.6 Backup repository . . . . .	178
6.5.7 MaxDB with ADINT/TSM . . . . .	178
6.5.8 References . . . . .	181
6.6 Summary of backup tools . . . . .	182
<b>Chapter 7. High availability and disaster recovery concepts . . . . .</b>	<b>185</b>
7.1 High availability solutions . . . . .	186
7.1.1 High Availability Cluster Multi-Processing (HACMP) . . . . .	187
7.1.2 Microsoft Cluster Service (MSCS) . . . . .	189
7.1.3 Oracle Real Application Cluster (RAC) . . . . .	190
7.1.4 Tivoli System Automation for Multiplatforms . . . . .	192
7.1.5 Other high availability solutions . . . . .	193
7.2 Disaster recovery solutions . . . . .	194
7.2.1 HACMP Extended Distance option (HACMP/XD) . . . . .	194
7.2.2 Metro Mirror . . . . .	195
7.2.3 Oracle Maximum Availability Architecture (MAA) . . . . .	197
7.2.4 Oracle Dataguard . . . . .	198
7.2.5 DB2 High Availability Disaster Recovery (HADR) . . . . .	199
7.2.6 Microsoft SQL Server Log Shipping . . . . .	201
7.2.7 Microsoft SQL Server Mirroring . . . . .	201
7.2.8 Other options from IBM . . . . .	202
7.3 Usage matrix . . . . .	202
<b>Part 2. Sample implementation and operation . . . . .</b>	<b>205</b>
<b>Chapter 8. Case study introduction . . . . .</b>	<b>207</b>
8.1 DB2 environment . . . . .	208
8.2 Oracle environment . . . . .	208



8.3 Drivers and clients mapping to server roles .....	209
<b>Chapter 9. DB2 backup using Tivoli Storage Manager .....</b>	<b>213</b>
9.1 Introduction .....	214
9.1.1 Data protection for SAP and DB2 .....	214
9.1.2 DB2 built-in Tivoli Storage Manager support .....	215
9.2 Planning for Data Protection for SAP with DB2.....	215
9.2.1 Lab environment overview and backup consideration .....	216
9.2.2 Backup methods to be used .....	218
9.2.3 Installation prerequisites .....	218
9.2.4 Tivoli Storage Manager software packages to be used .....	219
9.2.5 Defining backup policies .....	219
9.3 Configuration of Storage Agent.....	221
9.4 Configuration for DB2 backup .....	221
9.4.1 Configuration on the Tivoli Storage Manager server.....	221
9.4.2 Data protection configuration on SAP server .....	225
9.4.3 Optional DB2 configurations .....	230
9.4.4 Schedule configuration .....	231
9.5 Backup and restore using DB2 and the API client .....	235
9.5.1 Executing tablespace backup .....	235
9.5.2 Executing database backup .....	236
9.5.3 Executing restore .....	236
9.5.4 Monitoring backup and restore execution on DB2 .....	237
9.5.5 Finding backup and restore log files or information .....	238
9.5.6 Releasing backup tapes .....	242
9.6 Tivoli Storage Manager for ERP-DB2 installation .....	243
9.6.1 Required information for Data Protection for SAP .....	244
9.6.2 Installing Tivoli Storage Manager for ERP .....	244
9.6.3 System changes after Tivoli Data Protection for SAP installation..	246
9.7 Tivoli Storage Manager for ERP configuration .....	247
9.7.1 Configuration on the Tivoli Storage Manager server.....	247
9.7.2 Data protection configuration on SAP server .....	248
9.7.3 Manual configuration alternative .....	251
9.7.4 Automation options of Data Protection for SAP .....	254
9.7.5 Schedule configuration .....	255
9.8 Backup and restore using Data Protection for SAP .....	256
9.8.1 Executing backup .....	256
9.8.2 Executing restore .....	257
9.8.3 Backup and restore for DB2 partitions .....	257
9.8.4 Monitoring backup and restore execution .....	258
9.8.5 Getting reports from backup .....	259
9.8.6 Releasing tapes and backup expiration .....	262
9.9 Troubleshooting.....	262

9.9.1	Log files . . . . .	263
9.9.2	Configuration files . . . . .	263
9.9.3	Common error messages . . . . .	264
9.9.4	Other problems . . . . .	265
9.10	References . . . . .	265
<b>Chapter 10. Oracle backup using Tivoli Storage Manager for ERP . . . . .</b>		<b>267</b>
10.1	Introduction . . . . .	268
10.1.1	Data Protection for SAP and BACKINT . . . . .	268
10.1.2	Data Protection for SAP and RMAN . . . . .	269
10.2	Data protection planning for SAP with Oracle . . . . .	270
10.2.1	Lab environment overview and backup considerations . . . . .	270
10.2.2	Backup methods to be used . . . . .	272
10.2.3	Installation prerequisites for Data Protection for SAP - Oracle . . . . .	272
10.2.4	Tivoli Storage Manager software packages to be used . . . . .	273
10.2.5	Defining backup policies . . . . .	273
10.3	Tivoli Storage Manager for ERP - Oracle installation . . . . .	275
10.4	BR*Tools with Oracle RMAN configuration . . . . .	278
10.4.1	Tivoli Storage Manager server configuration . . . . .	278
10.4.2	SAP database server configuration . . . . .	279
10.4.3	Scheduling configuration . . . . .	285
10.5	Configuration of BR*Tools with the BACKINT interface . . . . .	288
10.6	References . . . . .	290
<b>Chapter 11. LAN-free backup and restore . . . . .</b>		<b>291</b>
11.1	LAN-free backup and restore . . . . .	292
11.2	Installation . . . . .	293
11.2.1	Atape driver installation . . . . .	293
11.2.2	Storage agent installation . . . . .	296
11.2.3	Configuration worksheets . . . . .	299
11.3	Setup and configuration of storage agent . . . . .	302
11.3.1	Configuration on the Tivoli Storage Manager client . . . . .	304
11.3.2	Configuration on the Tivoli Storage Manager server . . . . .	305
11.4	Setup and configuration for DB2 environment . . . . .	307
11.4.1	Required Tivoli Storage Manager definitions . . . . .	308
11.4.2	Tivoli Storage Manager API configuration . . . . .	310
11.4.3	Tivoli Storage Manager for ERP configuration . . . . .	312
11.5	Setup and configuration in Oracle environment . . . . .	316
<b>Chapter 12. FlashCopy backup and restore . . . . .</b>		<b>319</b>
12.1	Conventional FlashCopy method . . . . .	320
12.2	Introduction Advanced Copy Services for SAP . . . . .	321
12.2.1	Backup to Tivoli Storage Manager server without FlashCopy . . . . .	324
12.2.2	Backup to Tivoli Storage Manager server from FlashCopy . . . . .	325

12.2.3	Different options for the FlashCopy function . . . . .	326
12.2.4	Backup of offline transaction logs . . . . .	326
12.2.5	Expiration consideration . . . . .	328
12.3	Implement Advanced Copy Services for SAP in DB2 . . . . .	329
12.3.1	Data Protection for SAP (DB2) installation and configuration . . . . .	329
12.3.2	Customizing the DB2 environment . . . . .	331
12.3.3	Password handling methods . . . . .	332
12.3.4	CIM installation and configuration . . . . .	333
12.3.5	Data Protection for FlashCopy installation and configuration . . . . .	336
12.3.6	Data Protection for FlashCopy configuration . . . . .	338
12.3.7	Other prerequisites for the backup server . . . . .	343
12.3.8	FlashBack restore . . . . .	355
12.4	Implement Advanced Copy Services for SAP (Oracle) . . . . .	357
12.4.1	Data Protection for SAP (Oracle) installation and configuration . . . . .	358
12.4.2	Password handling methods . . . . .	359
12.4.3	CIM installation and configuration . . . . .	360
12.4.4	Data Protection for FlashCopy installation . . . . .	360
12.4.5	Data Protection for FlashCopy configuration . . . . .	362
12.5	FlashCopy cloning of SAP databases . . . . .	369
12.5.1	FCClone process . . . . .	370
12.5.2	Installation requirements for FCClone . . . . .	371
<b>Part 3.</b>	<b>Appendixes . . . . .</b>	<b>373</b>
	<b>Appendix A. DB2 basic operations . . . . .</b>	<b>375</b>
	Get information about the current DB2 instance . . . . .	376
	Listing the current active databases . . . . .	376
	Connecting to an active database . . . . .	376
	Configuration parameters for the current instance . . . . .	376
	Configuration parameters for the current database . . . . .	377
	Listing tablespaces information . . . . .	378
	Monitoring backup and restore . . . . .	380
	Listing backup history . . . . .	380
	Listing the backup history from DB2 . . . . .	380
	Listing backups from DB2 tables . . . . .	382
	<b>Appendix B. Oracle basic operations . . . . .</b>	<b>383</b>
	Oracle basic information . . . . .	384
	Get information about the Oracle instance . . . . .	384
	Listing the Oracle database files . . . . .	387
	Oracle control files . . . . .	388
	Oracle redo log files . . . . .	388
	Oracle tablespace list . . . . .	388
	Oracle data file list . . . . .	390

Oracle archived log list .....	390
Monitoring backup execution .....	392
<b>Abbreviations and acronyms</b> .....	<b>395</b>
<b>Related publications</b> .....	<b>399</b>
IBM Redbooks .....	399
Other publications .....	399
Online resources .....	402
How to get Redbooks .....	408
Help from IBM .....	408
<b>Index</b> .....	<b>409</b>

# Notices

This information was developed for products and services offered in the U.S.A.

IBM may not offer the products, services, or features discussed in this document in other countries. Consult your local IBM representative for information on the products and services currently available in your area. Any reference to an IBM product, program, or service is not intended to state or imply that only that IBM product, program, or service may be used. Any functionally equivalent product, program, or service that does not infringe any IBM intellectual property right may be used instead. However, it is the user's responsibility to evaluate and verify the operation of any non-IBM product, program, or service.

IBM may have patents or pending patent applications covering subject matter described in this document. The furnishing of this document does not give you any license to these patents. You can send license inquiries, in writing, to:  
*IBM Director of Licensing, IBM Corporation, North Castle Drive, Armonk, NY 10504-1785 U.S.A.*

**The following paragraph does not apply to the United Kingdom or any other country where such provisions are inconsistent with local law:** INTERNATIONAL BUSINESS MACHINES CORPORATION PROVIDES THIS PUBLICATION "AS IS" WITHOUT WARRANTY OF ANY KIND, EITHER EXPRESS OR IMPLIED, INCLUDING, BUT NOT LIMITED TO, THE IMPLIED WARRANTIES OF NON-INFRINGEMENT, MERCHANTABILITY OR FITNESS FOR A PARTICULAR PURPOSE. Some states do not allow disclaimer of express or implied warranties in certain transactions, therefore, this statement may not apply to you.

This information could include technical inaccuracies or typographical errors. Changes are periodically made to the information herein; these changes will be incorporated in new editions of the publication. IBM may make improvements and/or changes in the product(s) and/or the program(s) described in this publication at any time without notice.

Any references in this information to non-IBM Web sites are provided for convenience only and do not in any manner serve as an endorsement of those Web sites. The materials at those Web sites are not part of the materials for this IBM product and use of those Web sites is at your own risk.

IBM may use or distribute any of the information you supply in any way it believes appropriate without incurring any obligation to you.

Information concerning non-IBM products was obtained from the suppliers of those products, their published announcements or other publicly available sources. IBM has not tested those products and cannot confirm the accuracy of performance, compatibility or any other claims related to non-IBM products. Questions on the capabilities of non-IBM products should be addressed to the suppliers of those products.

This information contains examples of data and reports used in daily business operations. To illustrate them as completely as possible, the examples include the names of individuals, companies, brands, and products. All of these names are fictitious and any similarity to the names and addresses used by an actual business enterprise is entirely coincidental.

## COPYRIGHT LICENSE:

This information contains sample application programs in source language, which illustrate programming techniques on various operating platforms. You may copy, modify, and distribute these sample programs in any form without payment to IBM, for the purposes of developing, using, marketing or distributing application programs conforming to the application programming interface for the operating platform for which the sample programs are written. These examples have not been thoroughly tested under all conditions. IBM, therefore, cannot guarantee or imply reliability, serviceability, or function of these programs.

# Trademarks

IBM, the IBM logo, and [ibm.com](http://www.ibm.com) are trademarks or registered trademarks of International Business Machines Corporation in the United States, other countries, or both. These and other IBM trademarked terms are marked on their first occurrence in this information with the appropriate symbol (® or ™), indicating US registered or common law trademarks owned by IBM at the time this information was published. Such trademarks may also be registered or common law trademarks in other countries. A current list of IBM trademarks is available on the Web at <http://www.ibm.com/legal/copytrade.shtml>

The following terms are trademarks of the International Business Machines Corporation in the United States, other countries, or both:

AIX 5L™	FlashCopy®	Redbooks®
AIX®	GPFS™	Redbooks (logo)  ®
CICS®	HACMP™	System p5®
DB2 Universal Database™	IBM®	System p®
DB2®	Informix®	System Storage™
DRDA®	iSeries®	Tivoli®
DS6000™	OS/390®	TotalStorage®
DS8000®	OS/400®	WebSphere®
Enterprise Storage Server®	Passport Advantage®	z/OS®
ESCON®	POWER5™	
eServer™	pSeries®	

The following terms are trademarks of other companies:

ITIL is a registered trademark, and a registered community trademark of the Office of Government Commerce, and is registered in the U.S. Patent and Trademark Office.

IT Infrastructure Library, IT Infrastructure Library is a registered trademark of the Central Computer and Telecommunications Agency which is now part of the Office of Government Commerce.

Snapshot, and the NetApp logo are trademarks or registered trademarks of NetApp, Inc. in the U.S. and other countries.

Oracle, JD Edwards, PeopleSoft, Siebel, and TopLink are registered trademarks of Oracle Corporation and/or its affiliates.

ACS, Interchange, Red Hat, and the Shadowman logo are trademarks or registered trademarks of Red Hat, Inc. in the U.S. and other countries.

ABAP, BAPI, mySAP, mySAP.com, SAP ArchiveLink, SAP NetWeaver, SAP R/2, SAP R/3 Enterprise, SAP R/3, SAP Strategic Enterprise Management, SAP, and SAP logos are trademarks or registered trademarks of SAP AG in Germany and in several other countries.

VMware, the VMware "boxes" logo and design are registered trademarks or trademarks of VMware, Inc. in the United States and/or other jurisdictions.

ABAP, BAPI, mySAP, mySAP.com, SAP ArchiveLink, SAP NetWeaver, SAP R/2, SAP R/3 Enterprise, SAP R/3, SAP Strategic Enterprise Management, SAP, xApps, xApp and all SAP logos are trademarks or registered trademarks of SAP AG in Germany and in several other countries.

Image Viewer, J2EE, Java, JDBC, JRE, Solaris, Sun, Sun Java, and all Java-based trademarks are trademarks of Sun Microsystems, Inc. in the United States, other countries, or both.

Internet Explorer, Microsoft, MS, SQL Server, Windows Server, Windows, and the Windows logo are trademarks of Microsoft Corporation in the United States, other countries, or both.

Intel Pentium, Intel, Pentium, Intel logo, Intel Inside logo, and Intel Centrino logo are trademarks or registered trademarks of Intel Corporation or its subsidiaries in the United States, other countries, or both.

UNIX is a registered trademark of The Open Group in the United States and other countries.

Linux is a trademark of Linus Torvalds in the United States, other countries, or both.

Other company, product, or service names may be trademarks or service marks of others.

Archived

Archived



# Preface

In this IBM® Redbooks® publication, we give an overview of different data management topics related to a typical SAP® data center. The intrinsic functionality of SAP is not designed to completely handle all the tasks of a data center by itself, but the SAP system offers several interface possibilities to attach external tools to it to accomplish this task.

We explain SAP basic concepts and the issues with SAP data management. We introduce Tivoli® Storage Manager and all of its products that are related to SAP data management. We provide some comparison between database backup and recovery tools. Finally, we discuss data archiving using IBM DB2® CommonStore for SAP, and discuss high availability requirements and disaster recovery considerations.

The second part of this book discusses a practical implementation of SAP backup and recovery with Tivoli Storage Manager. We implement this setup on two separate SAP systems: one running DB2 and the other running Oracle® database. We also implement LAN-free backup and FlashCopy® scenarios.

In the sample implementation section, we show many different tasks, such as backup and restore, database recovery, backup monitoring, and tuning. We also cover some advanced backup/availability considerations, such as split mirror backup and standby databases.

This book helps individuals that operate an SAP environment to devise a strategy for a sound and comprehensive data backup solution using the IBM Tivoli Storage Management product family.

## The team that wrote this book

This book was produced by a team of specialists from around the world working at the International Technical Support Organization, Austin Center.

**Budi Darmawan** is a project leader with the International Technical Support Organization, Austin Center. He writes extensively and teaches IBM classes worldwide on all areas of Tivoli systems management. Before joining the ITSO 9 years ago, Budi worked in IBM Indonesia as lead implementor and solution architect. His current interests are application management, business system management, and Java™ programming.

**Miroslav Dvorak** is an IT Consultant with GC System a.s., an IBM Premier Business Partner in the Czech Republic. He graduated from the University of Economics in Prague with a Master's degree in Information Technology and has 10 years of experience in the IT field. His areas of expertise include data protection technologies, databases, IBM System p® and AIX, and HACMP™. He holds several certifications, including IBM eServer™ Certified Systems Expert - pSeries® HACMP for AIX 5L™, IBM Certified Advanced Database Administrator - DB2 UDB V8.1 for LUW, Oracle Certified Associate 10g, and IBM Certified Advanced Deployment Professional - Tivoli Storage Management Solutions 2006.

**Dhruv Harnal** is a Sr. Associate IT Specialist with IBM Software Labs, India. He has 4 years of experience in the IT industry, primarily on Tivoli Storage Manager, Tivoli Data Protection and Veritas Netbackup, IBM System Storage™ DS6800, SVC and DS8000®, Brocade Directors and Switches, IBM TotalStorage® Libraries, and Multi-path Drivers. He is also a BCFP, IBM certified IBM System p5® Virtualization expert.

**Gerson Makino** is an IT Architect at Technology Integration & Management (TIM) with IBM Brazil, supporting IBM international customers. He is an IBM Certified IT Specialist, with more than 23 years of IT experience in a wide range of platforms from midrange to IBM mainframes. His areas of expertise include Oracle, DB2, and Microsoft® SQL Server® databases on UNIX®, Linux®, and Windows® platforms, and Assembler/370, DB2, and CICS® for MVS and OS/390® mainframes. He is an IBM DB2 Certified Database Administrator on DB2 UDB V8.1 for Linux, UNIX, Windows, and zOS operating systems, and an Oracle Certified Professional on Oracle 8i, 9i, and 10g databases.

**Markus Molnar** is a Managing Consultant with IBM Australia. He has 6 years of experience in SAP Technology. He is an SAP certified Technology and OS/DB Migration consultant who has been working with different customers and projects running SAP on all kinds of platforms and databases. His areas of expertise include SAP Technology, Oracle, AIX, IXOS archiving server, and CommonStore for SAP.

**Rennad Murugan** is an Advisory IT Specialist with the Integrated Delivery Centre (IDC) based in Johannesburg, South Africa. He provides technical support to multiple customers for Tivoli Storage Manager and its associated client products, Disaster Recovery, TotalStorage Productivity Centre, and broad based Storage Area Network environments (ESS, DS, Brocade, McData, and others). Rennad joined IBM in 2004 and has spent the last 3 years as a storage administrator. He is a certified TSM Deployment professional and holds a degree in Commerce, majoring in Management and Information Systems.

**Marcos Silva** is a System Specialist with IBM Brazil. He has 8 years of experience in the IT field. For the last 4 years, he has been working with the Tivoli Storage Manager products portfolio. His areas of expertise include AIX®, Windows, Linux, and IBM Tape and Optical devices. He has been working for IBM since 2004. He is an ITIL® Certified Professional, IBM Certified Deployment Professional for Tivoli Storage Manager V5.4, and IBM Certified Administration Professional for Tivoli Storage Manager V5.4. He supports international and local companies in the Storage Field for IBM in Brazil.

Thanks to the following people for their contributions to this project:

Wade Wallace  
International Technical Support Organization, Austin Center

Mark Smith, Michell Spooner, Monty Poppe  
IBM UNIX Product Testing, Austin, TX

Kathy Pang  
Tivoli Storage Manager Level 2 Support, IBM San Jose, CA

## Become a published author

Join us for a two- to six-week residency program! Help write a book dealing with specific products or solutions, while getting hands-on experience with leading-edge technologies. You will have the opportunity to team with IBM technical professionals, Business Partners, and Clients.

Your efforts will help increase product acceptance and customer satisfaction. As a bonus, you will develop a network of contacts in IBM development labs, and increase your productivity and marketability.

Find out more about the residency program, browse the residency index, and apply online at:

[ibm.com/redbooks/residencies.html](http://ibm.com/redbooks/residencies.html)

## Comments welcome

Your comments are important to us!

We want our books to be as helpful as possible. Send us your comments about this book or other IBM Redbooks in one of the following ways:

- ▶ Use the online **Contact us** review Redbooks form found at:

[ibm.com/redbooks](http://ibm.com/redbooks)

- ▶ Send your comments in an e-mail to:

[redbooks@us.ibm.com](mailto:redbooks@us.ibm.com)

- ▶ Mail your comments to:

IBM Corporation, International Technical Support Organization  
Dept. HYTD Mail Station P099  
2455 South Road  
Poughkeepsie, NY 12601-5400

## Concepts

In this part, we discuss background concepts of SAP and Tivoli Storage Manager. The discussion is divided into the following chapters:

- ▶ Chapter 1, “SAP data management” on page 3
- ▶ Chapter 2, “SAP overview” on page 7
- ▶ Chapter 3, “SAP data protection considerations” on page 41
- ▶ Chapter 4, “Introduction to IBM Tivoli Storage Manager” on page 89
- ▶ Chapter 5, “IBM DB2 CommonStore for SAP” on page 115
- ▶ Chapter 6, “Database backup and recovery tools” on page 127
- ▶ Chapter 7, “High availability and disaster recovery concepts” on page 185

Archived

# SAP data management

This chapter gives an overview of this book. The discussion includes the following sections:

- ▶ 1.1, "SAP" on page 4
- ▶ 1.2, "Data management" on page 4
- ▶ 1.3, "Book structure" on page 5

## 1.1 SAP

SAP is an acronym for Systems Applications and Products. SAP provides a common centralized database for all the applications running in an organization. The application is assembled in such a versatile way that it handles all the functional departments within an organization.

SAP solutions are based on SAP NetWeaver®. It provides an integrated application platform, and this common technology platform helps reduce the total cost of ownership (TCO) across the entire IT landscape. This also supports the evolution of SAP Business Suite into a services-based architecture.

SAP's products focus on Enterprise Resource Planning (ERP), which SAP helped to pioneer. The company's main product is SAP ERP. SAP ERP is an integrated application that fulfills the core business needs of midsize to large organizations across all industries and market sectors.

Businesses are depending more and more on SAP. SAP is typically a critical application for those businesses, so it has to be protected. An SAP application must accommodate a business' requirements, which means the systems must be available and the data must be reliable. From a data management perspective, all SAP components communicate to a database instance. This database instance can be highly available, but data in the database must be backed up to ensure recoverability.

## 1.2 Data management

Data management deals with data storage, backup, and retrieval (or restore). In SAP, data management involves control files, executables, program customization, and its database. The largest issue in SAP data management is database backup and recovery, where you have to consider the following items:

- ▶ An SAP database is used by the SAP application, and the SAP application typically requires near continuous availability.
- ▶ AN SAP database is a single point of failure for all SAP components.
- ▶ AN SAP database can become quite large as the data accumulates and additional modules are integrated.



This book discusses several IBM Tivoli Storage Manager components that can help you perform data management functions in SAP. The software functions that we discuss are:

- ▶ Tivoli Storage Manager Server and Backup Archive Client for backup of the file system objects
- ▶ Tivoli Storage Manager for Database for database backup
- ▶ Tivoli Storage Manager for Enterprise Resource Planning for SAP specific backup requirements
- ▶ Tivoli Storage Manager for Advanced Copy Services for FlashCopy
- ▶ Tivoli Storage Manager for SAN for LAN-free backup (direct to SAN backup)

## 1.3 Book structure

This book is divided into the following parts and chapters:

- ▶ Part 1, “Concepts” on page 1 discusses the environment and product features.
  - Chapter 1, “SAP data management” on page 3, this chapter, introduces the book.
  - Chapter 2, “SAP overview” on page 7 gives an overview of SAP systems.
  - Chapter 3, “SAP data protection considerations” on page 41 explains some considerations for protecting data in an SAP system.
  - Chapter 4, “Introduction to IBM Tivoli Storage Manager” on page 89 describes Tivoli Storage Manager products features.
  - Chapter 5, “IBM DB2 CommonStore for SAP” on page 115 explains the role of DB2 CommonStore for SAP data archiving, and contrasts it with data backup.
  - Chapter 6, “Database backup and recovery tools” on page 127 provides an overview of different Tivoli Storage Manager related data backup and recovery tools that can be used for SAP data backup.
  - Chapter 7, “High availability and disaster recovery concepts” on page 185 discusses the options for implementing high availability and disaster recovery scenario for an SAP system to complement data backup solution.
- ▶ Part 2, “Sample implementation and operation” on page 205 provides a practical walkthrough of sample implementation schemes using Tivoli Storage Manager in an SAP environment.
  - Chapter 8, “Case study introduction” on page 207 lists the environment pertaining to the implementation.

- Chapter 9, “DB2 backup using Tivoli Storage Manager” on page 213 demonstrates a backup implementation for SAP with a DB2 database.
- Chapter 10, “Oracle backup using Tivoli Storage Manager for ERP” on page 267 demonstrates a backup implementation for SAP with an Oracle database.
- Chapter 11, “LAN-free backup and restore” on page 291 explains a SAN and LAN-free backup implementation with Tivoli Storage Manager.
- Chapter 12, “FlashCopy backup and restore” on page 319 demonstrates the use of FlashCopy with DB2 database and Tivoli Storage Manager.

# SAP overview

This chapter describes SAP. The discussion is divided into the following sections:

- ▶ 2.1, “SAP product history” on page 8
- ▶ 2.2, “SAP solutions and products” on page 11
- ▶ 2.3, “SAP NetWeaver overview” on page 13
- ▶ 2.4, “SAP architecture” on page 23
- ▶ 2.5, “SAP system topologies” on page 28
- ▶ 2.6, “Change and Transport System” on page 30
- ▶ 2.7, “SAP database” on page 35
- ▶ 2.8, “References” on page 39

## 2.1 SAP product history

In 1972, five former IBM employees started up a company called Systems Applications and Products in Data Processing in Germany. The company is most commonly known by the acronym SAP (the individual letters are sounded out). The goal was to develop standard application software for real-time business processing.

SAP R/2®, which ran on a mainframe architecture, was the first SAP version. R/3 was introduced and runs on a majority of platforms, including Microsoft Windows and different UNIX-type systems, such as AIX. R/3 is based on the client/server model. SAP NetWeaver is the latest product from SAP and provides the foundation of SAP's offered solutions. SAP NetWeaver enables the usage of Web and Java technologies.

SAP's products are generally focused around Enterprise Resource Planning (ERP). Their core product is the SAP ERP solution, which provides the functionality to manage product operations, cost accounting, assets, materials, and personnel. SAP offers its solutions for large, mid-size, and small businesses.

The first financial accounting software that SAP developed is known as the R/1 system and was made available in 1973. The "R" stands for real-time data processing. After SAP analyzed their product's database and dialog control system, they developed, announced, and released SAP R/2 in 1979. SAP R/2 is a mainframe based solution similar to R/1. It supported different languages and currencies.

SAP R/3® was announced in 1992. This version made the leap from mainframe computing to the three-tier architecture of user interface, application, and database. The client-server concept, a consistent look and feel among the graphical interfaces, consistent use of relational databases, and the ability to run on computers from different vendors were introduced to meet the needs of the enterprise software market.

The client-server architecture shown in Figure 2-1 on page 9 is the current standard in business software.

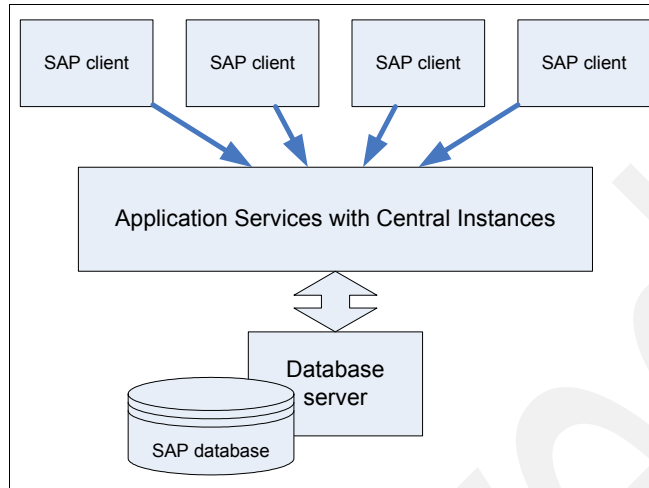

Figure 2-1 SAP three-tier architecture

SAP R/3 through Version 4.6C consisted of various applications on top of SAP Basis, which is SAP's set of middleware programs and tools.

When SAP R/3 Enterprise™ was launched in 2002, all applications were built on top of the SAP Web Application Server. Extension sets were used to deliver new features and keep the core as stable as possible. The Web Application Server contained all the capabilities of SAP Basis and enabled the use of Web technologies.

At the end of the 1990s, SAP announced the mySAP™.com® strategy. mySAP.com uses standard Web and Internet technologies, and links e-commerce solutions to existing ERP applications. SAP also develops SAP Workplace, which evolved to become an enterprise portal solution with role-based access to information.

SAP's latest integration and application platform is called SAP NetWeaver. SAP NetWeaver enables the integration of information, people, and processes inside and outside a company. With enterprise service-oriented architecture and SAP NetWeaver as foundation, SAP provides solutions to build end-to-end business processes.

The first edition of mySAP ERP was launched in 2003 and bundled previously separate products, including SAP R/3 Enterprise, SAP Strategic Enterprise Management™ (SEM), and extension sets. The SAP Web Application Server was wrapped into NetWeaver, which was also introduced in 2003.

A complete architecture change took place with the introduction of mySAP ERP in 2004. R/3 Enterprise was replaced with the introduction of ERP Central Component (SAP ECC). The SAP Business Warehouse, SAP Strategic Enterprise Management, and Internet Transaction Server were also merged into SAP ECC, allowing users to run them under one instance. Architectural changes were also made to support an enterprise services architecture to transition customers to a service-oriented architecture.

Figure 2-2 shows the SAP evolution.

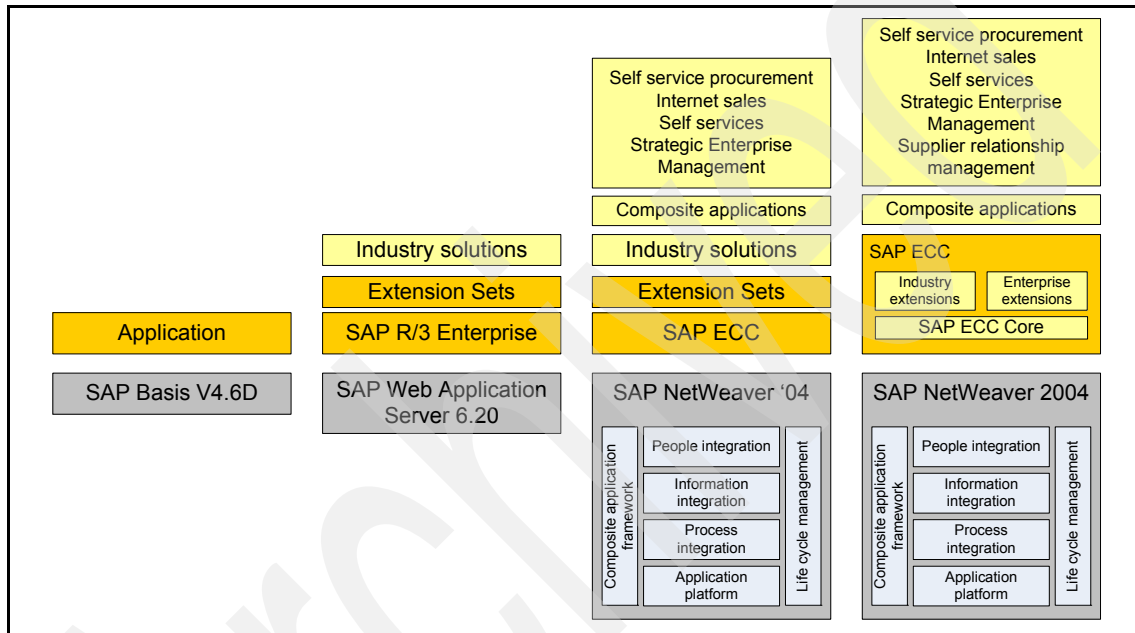

Figure 2-2 SAP evolution

Service-oriented architecture moves the ERP landscape toward Web services based business activities. This move increases adaptability, flexibility, openness, and efficiency of SAP. The move towards enterprise SOA helps companies reuse software components and not have to rely as much on in-house enterprise resource planning hardware technologies, which helps make ERP adoption more attractive for small- or mid-sized companies.

You can learn more about Enterprise SOA at the following address:

<http://www12.sap.com/platform/soa/index.epx>

## 2.2 SAP solutions and products

The discussion includes the following sections:

- ▶ 2.2.1, “Enterprise solutions” on page 11
- ▶ 2.2.2, “Business solutions” on page 13
- ▶ 2.2.3, “SAP solutions for small businesses and mid-size companies” on page 13

For more information about SAP solutions, go to the following address:

<http://www.sap.com/solutions/index.epx>

### 2.2.1 Enterprise solutions

Here we discuss the following enterprise solutions:

- ▶ “SAP Business Suite” on page 11
- ▶ “Duet” on page 12
- ▶ “SAP Manufacturing” on page 12
- ▶ “SAP Service and Asset Management” on page 12

#### **SAP Business Suite**

SAP Business Suite is a family of adaptive business applications, with a high level of integration and industry-specific functionality and scalability that allows easy collaboration over the Internet.

SAP solutions are based on SAP NetWeaver. It provides an integrated application platform that helps reduce the total cost of ownership (TCO) across the entire IT landscape. It also supports the evolution of SAP Business Suite into a services-based architecture.

SAP's products focus on Enterprise Resource Planning (ERP). The company's main product is SAP ERP. SAP ERP is an integrated application that fulfills the core business needs of mid-size to large organizations across all industries and market sectors. SAP offers a generic solution for over 20 industries, such as automotive, chemical, and telecommunications.

SAP ERP is one of five major enterprise applications in SAP's Business Suite, which includes the following applications:

- ▶ Customer Relationship Management (CRM)

With CRM, companies are able to acquire and retain customers, gain deep marketing and customer insight, and align an organization towards customer-focused strategies.

- ▶ **Enterprise Resource Planning (ERP)**  
ERP enables enterprises to perform financials, human capital management, procurement and logistics, product development and manufacturing, and sales and service, supported by functionality for analytics, corporate services, and user service delivery. It increases efficiency within your organization and helps extend end-to-end business processes to your customers, partners, and suppliers.
- ▶ **Product Lifecycle Management (PLM)**  
PLM helps manufacturers by giving them a single source of all the product-related information necessary to collaborate with Business Partners and to support product lines.
- ▶ **Supply Chain Management (SCM)**  
SCM helps companies enhance operational flexibility across global enterprises and provide real-time visibility for customers and suppliers.
- ▶ **Supplier Relationship Management (SRM)**  
With SRM, customers can collaborate closely with suppliers and integrate sourcing processes with applications throughout the enterprise to enhance transparency and lower costs.

SAP Business Suite applications help manage the most critical business processes. Using them together adds even more value to your organization through seamless integration.

### **Duet**

The Duet software enables seamless access to SAP business processes and data through Microsoft Office. It revolutionizes how information workers interact with enterprise applications. Duet is the result of a collaboration between SAP and Microsoft.

### **SAP Manufacturing**

SAP Manufacturing integrates manufacturing with other enterprise processes. It takes into account the planning, execution, quality, maintenance, and environment, health, and safety aspects of manufacturing.

### **SAP Service and Asset Management**

SAP Service and Asset Management provides the tools to improve service management, service parts management, and asset management.



## 2.2.2 Business solutions

SAP also provides other business solutions that are not included in the enterprise solution. Those product offerings are:

- ▶ SAP Solutions for Enterprise Performance Management
- ▶ SAP Solutions for Governance, Risk, and Compliance (GRC)
- ▶ SAP Solutions for Information Workers
- ▶ SAP Solutions for RFID
- ▶ Solution extensions
- ▶ Software from SAP and Business Objects

## 2.2.3 SAP solutions for small businesses and mid-size companies

SAP offers ready solution packages for small and mid-size companies that can be tailored and adapted to a company's needs. The business management and business intelligence solutions are:

- ▶ SAP Business One
- ▶ SAP Business ByDesign
- ▶ SAP Business All-in-One
- ▶ Crystal Reports Server
- ▶ BusinessObjects Edge Series

## 2.3 SAP NetWeaver overview

SAP NetWeaver provides an open integration and application platform and permits the integration of the Enterprise Services Architecture. This allows business processes to be integrated as needed in a structured manner.

SAP NetWeaver is the basis for SAP solutions, as shown in Figure 2-3.

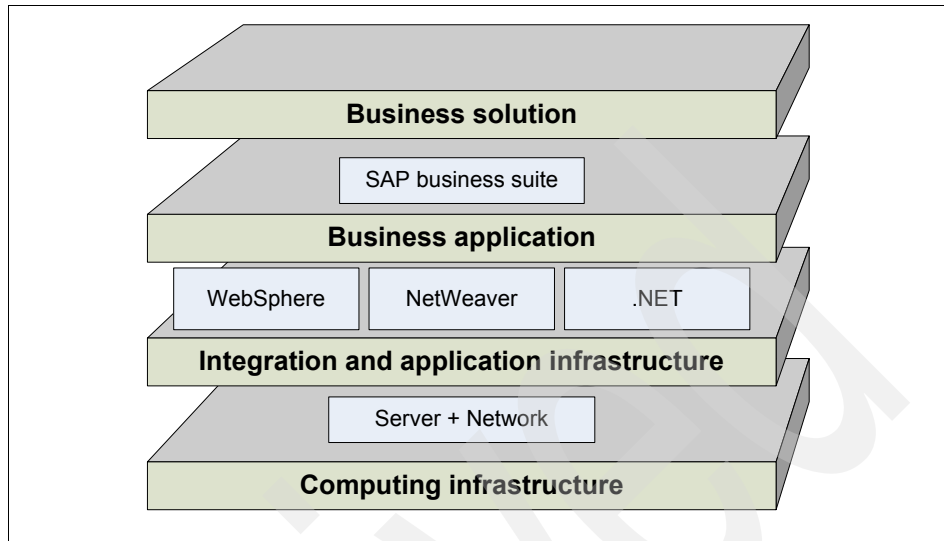

Figure 2-3 SAP NetWeaver architecture

SAP NetWeaver is built using open standards and industry *de facto* standards. It can be extended to interoperate with Microsoft .NET, Sun™ Java™ Enterprise Edition, and IBM WebSphere® products.

SAP NetWeaver's allow enterprises to run their business on a single, integrated platform that includes both applications and technology. Industry analysts refer to this type of integrated platform offering as an “applistructure” (applications + infrastructure). This approach is driven by the industry's need to lower IT costs through an enterprise architecture that is:

- ▶ More flexible,
- ▶ Better integrated with applications
- ▶ Built on open standards to ensure future interoperability and broad integration
- ▶ Provided by a vendor that is financially viable for the long term

### 2.3.1 Key capabilities

Figure 2-4 on page 15 shows SAP NetWeaver's key capabilities.

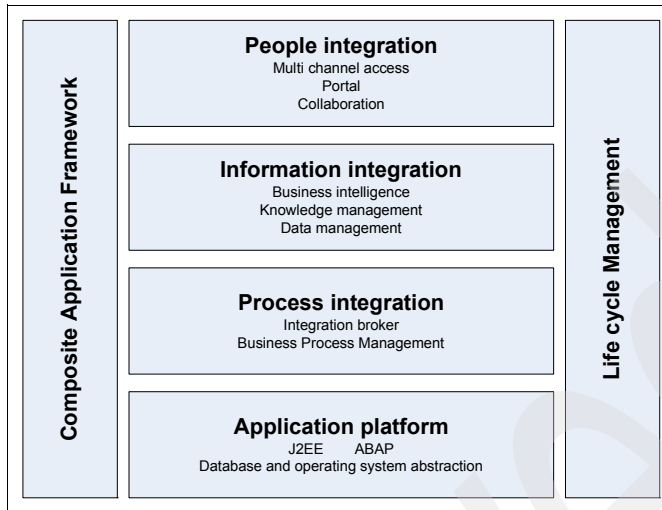

Figure 2-4 SAP NetWeaver key capabilities

As shown in Figure 2-4, SAP NetWeaver has the following key capabilities:

► **People integration**

People integration brings together the right functionality and the right information to the right people. On the people level, SAP NetWeaver allows a seamless user experience across different systems, which allows collaboration functions and pervasive access.

► **Information integration**

Information integration provides both structured and unstructured information that is consistent and accessible. Users have constant access to consistent information, no matter where it is stored.

► **Process integration**

The Integration Broker provides a technical infrastructure for XML-based message exchange to enable the integration of SAP systems with each other on the one hand, and SAP and non-SAP systems on the other.

With the Integration Broker, integration knowledge is shipped in the form of predefined integration scenarios. Furthermore, the Integration Broker provides a set of integrated tools for creating and managing all integration-relevant information. Processes are controlled from the Business Process Management functions.

- ▶ Application platform

The application server provides a complete development infrastructure on which you can develop, distribute, and execute platform-independent, robust, and scalable Web services and business applications. The Application Server supports Advanced Business Application Programming (ABAP™), Java, and Web services applications. The application platform is the basis of SAP NetWeaver and is implemented by the application server.

- ▶ Solution Lifecycle Management

Solution Lifecycle Management (SLCM) provides you with the technology required for the entire life cycle of your solution, from its implementation, through running a live system, to continuous modifications and upgrades. This includes the capabilities to perform data archiving.

- ▶ Composite Application Framework

Different services and people with different roles within different departments need to work together to drive business processes. The most effective approach for such solutions is the composite methodology, which allows reuse and composition of different services, user interface components, and business processes into flexible solutions. Composite Application Framework (CAF) leverages all layers of SAP NetWeaver.

In addition to the key capabilities described, SAP NetWeaver covers the following aspects:

- ▶ Security

In today's world of collaborative business processes and open system environments, security no longer means just adding a firewall and using passwords to log on. It requires a complete approach that applies to both the IT landscape and also to issues that arise beyond your organization. The infrastructure of the SAP NetWeaver technology platform supports comprehensive security features for heterogeneous environments.

- ▶ Databases

- MaxDB

MaxDB is SAP's own relational database system. You can use it in SAP solutions as a less expensive alternative to databases from other vendors. MaxDB is delivered as standard under NetWeaver Full Use License.

- SAP liveCache Technology

SAP liveCache Technology is an object-based enhancement of the MaxDB database system. You can use SAP liveCache Technology either as a normal relational database system, or as a main memory-based special database system. SAP liveCache OneDB combines these two options.

SAP liveCache Technology is currently delivered as part of the SAP SCM/APO solution. Its use in other SAP solutions is forthcoming.

▶ **SAP Knowledge Warehouse**

The SAP Knowledge Warehouse is the SAP Solution for all the material used in training, documentation, and handbooks.

It is an integrated environment for creating, translating, presenting, distributing, and managing information objects.

## **2.3.2 Database positioning**

Different areas of SAP NetWeaver's key capabilities show that the database-related aspects are covered in Application platform and Solution Lifecycle Management.

- ▶ The Application platform discusses database support. It also offers data archiving functionality as one of its many business services.
- ▶ Under Solution Lifecycle Management, the following database aspects are discussed:
  - Database system management
  - Database high availability
  - Data archiving

The SAP Database is discussed in more detail in 2.7, "SAP database" on page 35.

### 2.3.3 Application platform in detail

The application platform is the basis of SAP NetWeaver and is implemented by the application server. The application server provides a complete infrastructure on which you can develop, distribute, and execute platform-independent, robust, and scalable Web services and business applications. The application server supports ABAP, Java, and Web services, as shown in Figure 2-5.

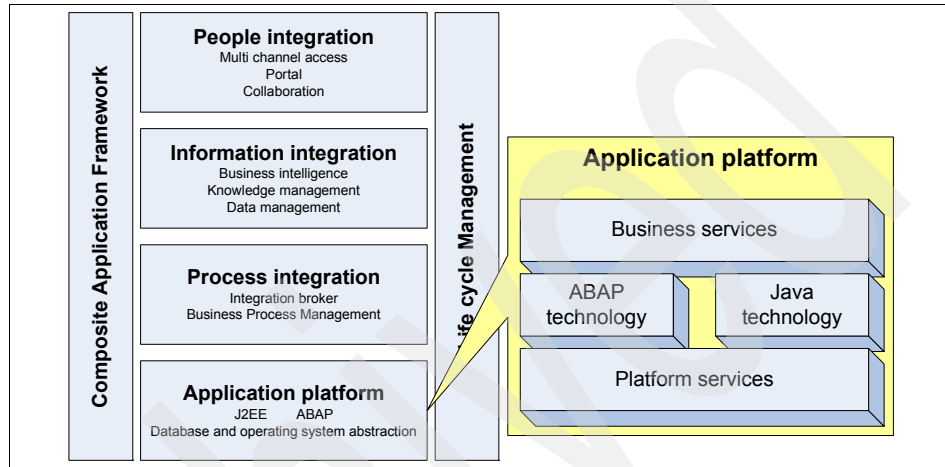

Figure 2-5 SAP NetWeaver application platform key capabilities

This section discusses the following:

- ▶ “Platform-wide services” on page 18
- ▶ “ABAP technology” on page 19
- ▶ “Java technology” on page 20
- ▶ “Business services” on page 22

#### Platform-wide services

The platform-wide services provide support for the different databases and operating services that are supported by SAP NetWeaver. It allows the ABAP, Java, and both ABAP and Java application servers to run seamlessly on different database and operating system platforms.

The platform-wide services also allows exchange of application information. The exchange can be between different SAP systems or SAP and external systems.

## **ABAP technology**

Advanced Business Application Programming (ABAP) is a programming language developed by SAP to develop business applications. One fundamental application area is for processing data in a central database.

The SAP Application Server provides a complete development and runtime environment for ABAP-based applications. It is optimized for the development of highly scalable business applications.

The ABAP development environment is used for both developing completely new applications and extending and modifying SAP standard applications. The entire infrastructure of the Web application server can be used to support creation of the complex applications by large groups of developers.

The ABAP technology can be used to implement complete applications, including the user interfaces. However, it is also possible to implement only the core components, such as the business logic and data persistence in ABAP. The user interface can use a Java-based interface or other application. The user-interface can use the defined interfaces RFC, BAPIs, Web Services, and so on.

The ABAP development and runtime environment makes it possible to develop complex business applications without being concerned explicitly about technical details such as process or memory administration, multi-user capability, database connections, or similar issues. These applications are provided in the base services or are integrated directly into the ABAP runtime. The application development is similarly independent of the underlying platform. The application server decouples the application coding completely from the operating system and database that are used.

A central feature of the ABAP development is the direct integration of database access. The runtime environment ensures that every ABAP program automatically receives an open connection to the central database in the system, so that an application programmer does not need to worry about opening and closing database connections. ABAP objects contain Open SQL, a platform-independent SQL dialect that is a direct component of the language. It can be used to execute database accesses directly without having to use an API or a class library. Buffer mechanisms on the application server-side ensure that highly-scalable, complex database accesses are possible.

In addition to Open SQL, object services are offered that enable persistent objects to be defined, whose persistence is completely taken over by the runtime.

The runtime system provides its own lock mechanism for synchronizing accesses to data in the database. This prevents two parallel transactions from being able to change the same data in the database. Mapping business processes to transactions ensures the integrity of the data.

## Java technology

The Java Application Server is a fully compliant Java 2 Enterprise Edition (J2EE™) 1.3 application server. The J2EE standard has been defined by the Java Community according to the rules of the Java Community Process. SAP has been a member of the Executive Committee of the Java Community since November 2002.

The Java application server architecture avoids single points of failure in the cluster environment by load balancing client requests between server processes. Requests are parsed by the Java dispatcher and forwarded for processing to individual server processes. The server processes provides a failover system to preserve the state of the user session. If a server process becomes unavailable, the state of the user session is recovered transparently on another available server process.

Some features and tools of the Java application server are:

- ▶ Java application server implements the Java Authentication and Authorization Service (JAAS) API, enabling efficient user and authentication management. Pluggable login modules based on the JAAS support various authentication methods, including basic authentication, log-on tickets, X509 certificates, Security Assertion Markup Language (SAML), and Web Services Security (WSSec). This enables integration in single sign-on (SSO) environments. The application server allows for filtered communication over firewalls and packet filtering devices. The transport layer security on the Java application server is implemented with support for Generic Security Services API, the Java Cryptography Extension, and Secure Network Communications (SNC) for SAP-specific communication.
- ▶ Web services are Web-based interfaces that can be integrated into a company's business scenarios. Using Web services enables you to combine functions implemented on different software components into a single process. Web services are self-contained, modularized, and executable entities that can be published, searched for, and accessed across a network. The Java Web Service infrastructure allows developers to integrate Web services, irrespective of where they reside or how they are implemented. Therefore, business processes spanning different systems, both intra-company and cross-company, can be implemented.



- ▶ The Open SQL for Java framework provides a database abstraction level for truly portable database-independent applications. Open SQL for Java enhances performance by providing statement pooling and table buffers, caches open database connections in a server-side database connection pool transparently to applications, and facilitates maintenance by monitoring and tracing facilities. The Web AS Java also provides the Java Dictionary as a central repository for database objects. The Java Dictionary is fully integrated in the NetWeaver Developer Studio and enables portable definition, creation and modification of database objects, manages database objects' life cycle, and performs statement checks against Open SQL grammar and table definitions.
- ▶ The SAP NetWeaver Administrator provides a central entry point to the whole SAP NetWeaver system landscape. The SAP NetWeaver Administrator enables starting and stopping of systems, services, and applications, as well as technical configuration, user management, system monitoring, log viewing, and application and performance tracing.
- ▶ The SAP NetWeaver Developer Studio provides a complete set of development tools covering all aspects of Java development to develop, build, deploy, and execute applications centrally. The SAP NetWeaver Developer Studio also provides access to the NetWeaver Development Infrastructure (NWDI). The NWDI enables distributed and team-oriented development through central source code storage and versioning, component-based build process, development landscapes, and transports management.
- ▶ Web Dynpro provides a client-independent programming model for developing professional user interfaces. Web Dynpro tools support application development during the implementation and design phases. Web Dynpro applications are developed with a declarative programming approach to produce a platform-independent metamodel. The necessary source code is then generated automatically and executed at runtime. You can access the source code of your application from the development environment and thus define events for your Web Dynpro application. The generated source code contains separate, specially marked areas for this purpose.

## Business services

Table 2-1 gives an overview of some of the business services integrated into SAP NetWeaver.

Table 2-1 SAP NetWeaver business services overview

Business service	Description
Smart forms	Smart Forms are used to create and edit forms for mass printing in SAP systems. As well as standard output to a printer, Smart Forms are also compatible with e-mail, fax, and the Internet (using generated HTML output).
SAPscript	SAPscript was the original tool for printing forms and creating texts in the SAP system. The form-related functions in SAPscript were replaced by Smart Forms in SAP Basis Release 4.6C.
ArchiveLink	ArchiveLink is a system that links archived documents and related application documents that have been created in the SAP system.
Content server	Content Server is an SAP NetWeaver content storage system for document-driven applications and business processes.
SAP business workflow	SAP Business Workflow is a workflow management system that automates and visualizes the business processes of SAP applications.
Organizational management	For many business or HR processes, you need to map the structure of your organization or enterprise according to tasks or functions. You can use Organizational Management to map organizational and reporting structures, and keep a record of any changes.
Records management	Records Management also offers functions that are beyond conventional records management systems. You have direct and secure access to archived documents. You can save Office documents and notes directly to a record. In addition to documents, you can include other electronic elements such as business objects, transactions, reports, and workflows into record management from the local SAP system, other SAP systems, or non-SAP systems. These options enable the record to show all information objects for a business process, independently of the media involved.

For more information about available Business Services, visit the following address:

[http://help.sap.com/saphelp\\_nw04/helpdata/en/2c/ed8e3f55b20617e1000000a114084/frameset.htm](http://help.sap.com/saphelp_nw04/helpdata/en/2c/ed8e3f55b20617e1000000a114084/frameset.htm)

## 2.4 SAP architecture

The design of the SAP NetWeaver Application Server is aimed at providing an exceptionally high level of robustness and maintainability for the applications running on it.

With Virtual Machine Container technology, SAP allows Java applications to be executed with a similar level of robustness as software developed in ABAP. The aim is to isolate individual users from each other as securely as possible to avoid any unwanted restrictions. In order to provide an optimal runtime environment for selected scenarios with especially high demands on a narrow ABAP-Java coupling, SAP Java VM can also run integrated in the ABAP work process.

An SAP system consists of SAP instances. An SAP instance is a group of processes that are started and stopped at the same time. SAP NetWeaver 7.0 has the following instances:

- ▶ Central instance
- ▶ Central services instance
- ▶ Database instance
- ▶ Dialog instance

All instances, except the database instance, are identified by an instance number, which is a two-digit number between 00 and 97 that is unique on a host. Instances can reside on one host, or they can be distributed on several hosts.

The usage type determines the role that a system plays in a particular scenario. They represent the capabilities offered by a collection of installed and configured software components. Usage types are a new structuring element of an SAP NetWeaver system on a technical level.

## 2.4.1 Technical components

This section discusses the technical components of an SAP NetWeaver. Figure 2-6 shows the technical components. To retain clarity, a few communication channels are not included in the diagram.

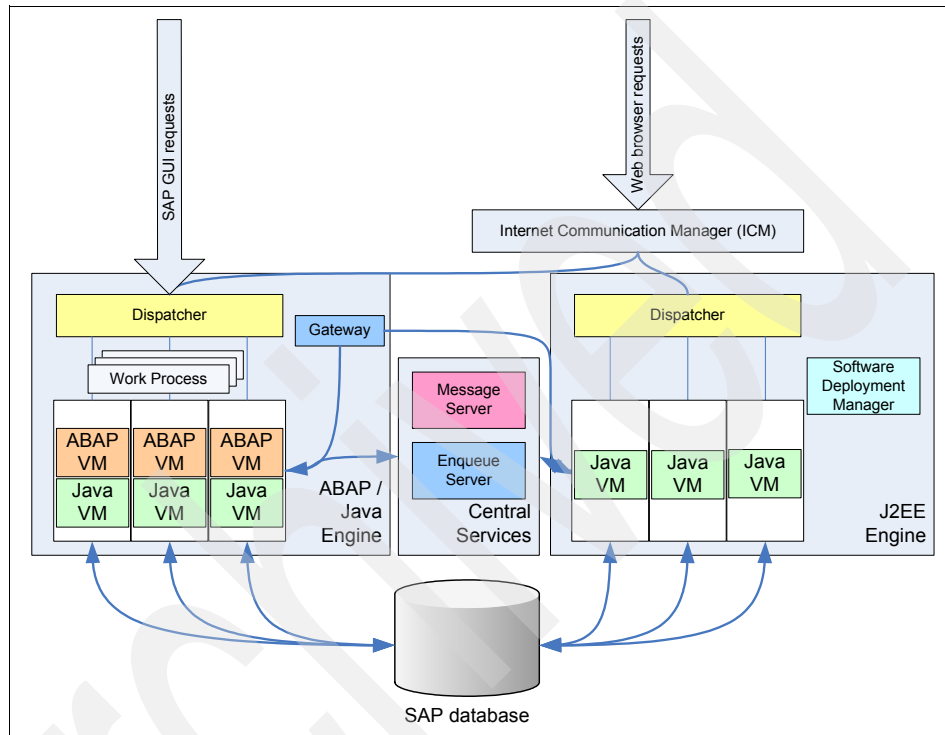

Figure 2-6 SAP NetWeaver architecture

There are several installation options for the SAP NetWeaver application server:

- ▶ ABAP System with integrated VM Container. With this installation, you can run ABAP programs and selected SAP Java applications.
- ▶ Java system. With this installation, you can run J2EE applications but not any ABAP programs.
- ▶ ABAP and Java system.

The components are:

► Dispatcher

The dispatcher is the central process on an application server. It distributes the requests to the work processes. If all the processes are occupied, the requests are stored in the dispatcher queue. In addition to other tasks, the SAP dispatcher is responsible for the following principle tasks:

- Initialization, reading profile parameters, starting work processes, and logging on to the message server
- Evenly distributing the transaction load across work processes
- Connecting to the GUI layer
- Organizing communication processes

► Message server

The message server exchanges messages and balances the load in the SAP system. Only one message server can run on each Java application server or ABAP application server usage type. The message server handles the communication between the dialog instances and also supplies information to the SAP Web dispatcher about load balancing.

► Enqueue server

The enqueue server contains a lock table that handles logical database locks plus infrastructure locks set by the Java server process. The enqueue server also synchronizes data in a Java cluster. In usage type AS ABAP, the enqueue server handles only locks on data objects.

► Work processes

An SAP application server has to process SAP requests from multiple front ends. The application server has the use of a dispatcher, which gathers the requests and transfers them for processing to the work processes. The work processes then execute the desired requests (for example, an ABAP program).

Here are the following types of work processes:

<b>Dialog</b>	Executes dialog programs (ABAP).
<b>Update</b>	Asynchronous database changes (is controlled by a COMMIT WORK statement in a dialog work process).
<b>Background</b>	Executes time-dependent or event-controlled background jobs.
<b>Enqueue</b>	Executes locking operations (if SAP transactions have to synchronize themselves).
<b>Spool</b>	Print formatting (to printer, file or database).

Several dialog work processes usually run on one application server. There are usually only one or two other types of work processes.

A work process consists of a screen processor, the ABAP interpreter, the database interface, and the task handler that calls these programs.

▶ Internet Communication Manager (ICM)

The ICM sets up the connection to the Internet. It can process both server and client Web requests. It supports the protocols HTTP, HTTPS, and SMTP. The SAP Web AS may be a Web server or a client.

▶ Internet Graphics Service (IGS)

The Internet Graphics Service (IGS) constitutes the infrastructure to enable the application developers to display graphics in an Internet browser with a minimum of effort.

▶ SAP Gateway

The SAP Gateway provides a remote function call interface between the SAP instances, within an SAP System, and beyond system boundaries.

▶ Software Deployment Manager

The Software Deployment Manager (SDM) is a tool with which you can manage and deploy software packages, in the form of Software Deployment Archives (SDA) and Software Component Archives (SCA), that you receive from SAP.

## 2.4.2 Central instance

Every SAP system must have one central instance, which includes:

- ▶ Usage type ABAP application server
  - Dispatcher
  - Work processes (dialog, batch, spool, or update)
  - Gateway
  - Internet Communication Manager (ICM)
  - Internet Graphics Service (IGS)
- ▶ Usage type Java application server
  - Java dispatcher
  - Server processes
  - Software Deployment Manager (SDM)
  - Internet Graphics Service (IGS)

When the central services are located on a separate instance, the configuration of the central instance is the same as the configuration of the dialog instance. If the central services are not installed as a separate instance, the message server and enqueue server are part of the central instance.

### 2.4.3 Central services instance

The central services instance forms the basis of communication and synchronization for the Java or ABAP clusters – Java central services (SCS) instance or ABAP central services (ASCS) instance. The ASCS can only be installed for a high availability system with the ABAP application server. A central services instance consists of the message server and the enqueue server.

### 2.4.4 Database instance

The database instance is a mandatory installation component for the installation of an SAP system. Java application server and ABAP application server have separate database schemes. When ABAP with Java application server (also known as Java Add-In) is installed, the AS ABAP and the AS Java database schemes are installed in the same database. We do not recommend using separate databases for the AS Java and AS ABAP scheme.

The AS Java scheme, named SAP<SAPSID>DB, holds the data stored by AS Java and all deployed application objects. The ABAP scheme is named SAP<SAPSID>.

### 2.4.5 Dialog instance

Dialog instances are optional and can be installed on separate hosts. Dialog instances include:

- ▶ Usage type ABAP application server
  - Dispatcher
  - Work Processes (dialog, batch, spool, or update)
  - Gateway
  - Internet Communication Manager (ICM)
  - Internet Graphics Service (IGS)
- ▶ Usage type Java application server
  - Java dispatcher
  - Server processes
  - Internet Graphics Service (IGS)

When you add a dialog instance, it belongs to the software cluster. The central instance initiates an update of the dialog instance so the dialog instance has access to the deployed applications on that cluster (this also includes usage types such as EP or PI).

A cluster always needs a load balancing solution, for example, SAP Web dispatcher.

## 2.5 SAP system topologies

This section introduces some basic topologies for an SAP system. A topology is a schematic description of the layout of a system or network. In terms of an SAP system, the topology describes the arrangement of an application server as a cluster with one or more physical machines. The topology of an SAP system also addresses scalability, performance, availability, maintainability, and security.

SAP system installation may require the application server to scale up or scale down an application. Therefore, scalability is very important for efficiency, performance, and cost reduction.

The simplest topology is a single machine topology. This type of topology presents a configuration where all components reside on the same machine. It is easy to install and maintain and is therefore appropriate for first-time installations when you want to test and familiarize yourself with the functions of the application server. At this stage, it is easy to determine what kind of system landscape is needed.

Although this topology is easily and cheaply configurable, it has some drawbacks that you must consider. Because all components are located on a single machine, they compete for resources, which affects the processes performance. In addition, the components cannot be secured with firewalls and high availability is not supported.

Figure 2-7 on page 29 shows a single machine topology.



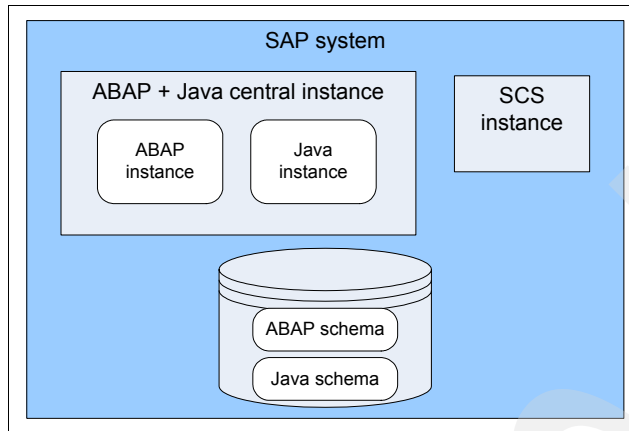

Figure 2-7 Single machine topology

This configuration can be enhanced by assigning additional machines. For an example, you can separate the database instance. Separating the database instance to a separate host avoids resource contention for database processing. Apart from the improved performance, locating the database instance on another physical machine may allow you to implement high availability solutions. The database is a critical component and it is therefore very important to ensure high availability for it. Nevertheless, hosting the database instance on a separate machine adds to the complexity because you need to configure, maintain, and back up another entity.

Further separation can be performed and additional instances can be installed on different machines. Figure 2-8 shows a distributed topology.

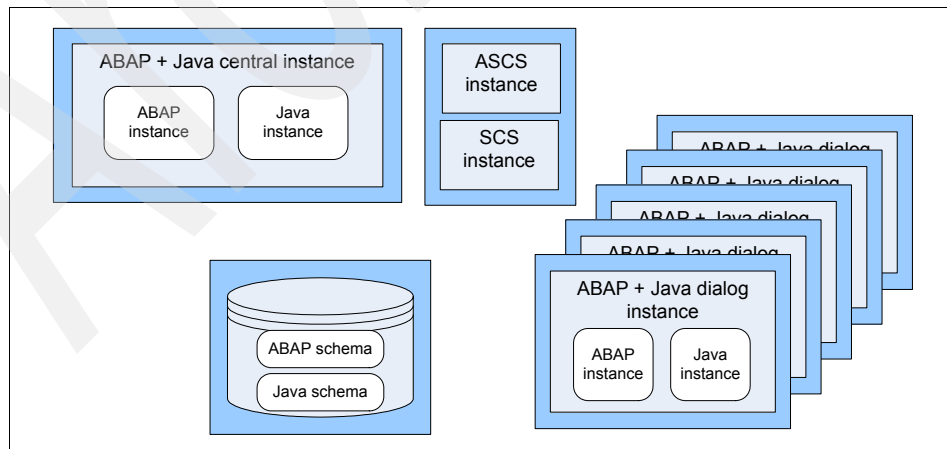

Figure 2-8 Multiple machines topology

In a cluster environment, there is the notion of vertical and horizontal scaling. The concepts are:

- ▶ Vertical scaling is a technique for a cluster arrangement that includes many dialog instances created on one physical machine. The single machine needs enough resources to handle this configuration. We recommend that you monitor performance and memory before adding a new dialog instance. You can set up vertical scaling whenever required, as it does not need any special installation steps. Figure 2-9 shows vertical scaling topology.

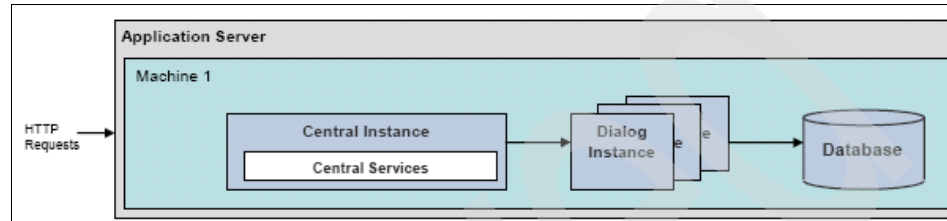

Figure 2-9 SAP vertical scaling topology

- ▶ Horizontal scaling is another clustering technique that separates the dialog instances across multiple physical machines. This configuration provides failover support and so ensures high availability of the application server processes. The disadvantages of this strategy are the increased installation and maintenance effort and also the cost of additional machines. Figure 2-10 shows SAP horizontal scaling topology.

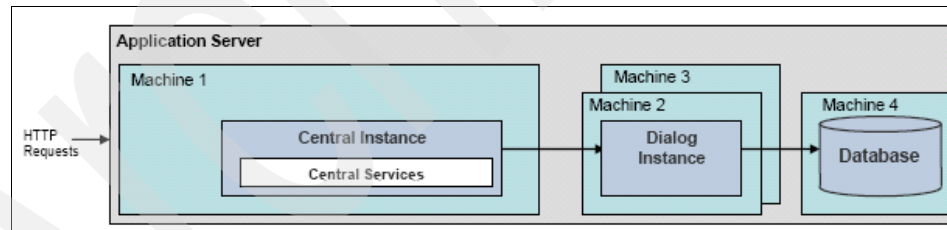

Figure 2-10 SAP horizontal scaling topology

## 2.6 Change and Transport System

Change and Transport System (CTS) is a tool that helps you to organize development projects. It oversees the development in ABAP Workbench, customizing functions, and then transport the changes between the SAP systems in your system landscape. You can transport Java objects, ABAP objects, and SAP-specific non-ABAP technologies (such as Web Dynpro Java or SAP NetWeaver Portal) in your system landscape.

## 2.6.1 Clients and their roles

When you log on to an SAP System, you log on to a particular client of this system. Any activities you carry out in the system are always carried out in one client. When you plan your SAP system landscape, you must consider which clients you need for which activities. By assigning activities to be performed in a client, you give each client a particular role. This section describes important client roles.

Because you need to adapt the SAP software for your own business needs, each SAP system landscape requires a client where custom settings, and possibly ABAP Workbench developments, can be made. This client is known as the Customizing and development client, or Customizing client (CUST).

Before you can use the Customizing settings and Workbench developments productively, you need to test them extensively for errors. Any faulty settings can seriously disrupt productive operations, and, at worst, lead to the loss of productive data. The integrated nature of the various SAP applications means that there are many dependencies between the different Customizing settings. Even an experienced Customizing developer may not discover these dependencies immediately. The correctness of the settings can only be guaranteed with extensive testing. The client where these tests are made is the Quality Assurance Client (QTST).

A separate client is required for productive use of the SAP System. So that this client can be used without disruption, it is essential that no Customizing settings or Workbench developments are made here, and also that no tests are carried out. This client is known as the Production Client (PROD).

These three clients, CUST, QTST, and PROD, typically exist in every system landscape. Standard system landscapes have precisely one client for each of these client roles. We recommend that you make all your Customizing settings in a single Customizing client, and then use the CTS to transport them to the other clients. We also recommend that you do not make any Customizing settings or Workbench developments in the quality assurance or production clients. You can make sure of this by applying the appropriate client settings.

In addition to the main clients, you can also set up other clients for other tasks. However, you must remember that each extra client takes up additional system resources (main memory and database space). They also need to be administrated. For example, you need to set up and administrate access authorization for the users, and also distribute any changes to other clients with the CTS. You must weigh up the advantages and disadvantages of setting up other clients.

Examples of other client roles are:

- ▶ Development test client (TEST)
- ▶ Prototype or sandbox client (SAND)
- ▶ Training client (TRNG)

## 2.6.2 System landscape

The system landscape contains all the SAP systems that you have installed. After you decide which clients you need and which roles you want them to have, you need to decide how to distribute them among the different SAP systems. You can set up multiple clients independently of one another in a single SAP system. However, when you configure the data, you must remember that cross-client Customizing settings and Repository objects are identical for all clients in a single SAP System. Changes made in one client apply immediately to all clients in the system.

When you install an SAP system, a transport directory is set up for it. The transport directory is the directory that manages all data to be transported between SAP systems. CTS uses this directory to store transport data. In most cases, all SAP systems in a transport domain have a common transport directory.

To protect your production system from unwanted or faulty changes, we recommend that you take special care in separating your development system from your production system. Define policies and procedures for making changes and transporting them into your production system. Avoid making changes in your production system!

In regard to your system landscape, we suggest a three-tier system that consists of separate development, quality assurance, and production systems. The three systems share a common transport directory. With this setup, you can thoroughly make and test changes without interfering with your productive operations. The three systems landscape is the recommended configuration.

### Three-tier system landscape

We recommend a three-tier system landscape in which each of the central clients has its own SAP system. The three systems consist of a development system (DEV), a quality assurance system (QAS), and a production system (PRD). The development system contains the Customizing client CUST, the quality assurance system contains the quality assurance client QTST, and the production system contains the production client PROD. Figure 2-11 on page 33 shows the three-tier system landscape.

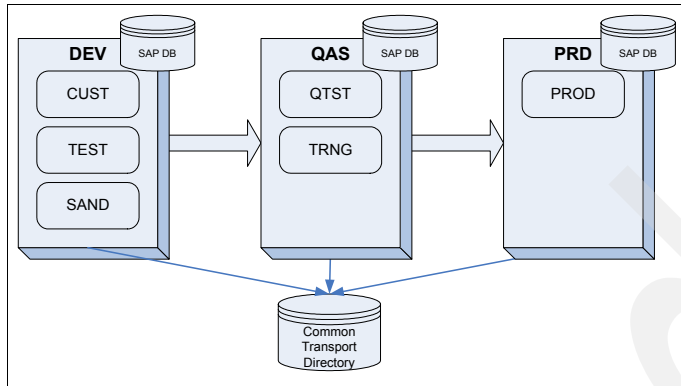

Figure 2-11 Three-tier system landscape

Make all changes to Customizing data and Repository objects in the CUST client. When you release the corresponding change requests, they are transported into the QTST client. This means that changes to cross-client data only appear in the quality assurance client after the transport. In the quality assurance client, you can test whether the transports are complete, or whether any linked changes are missing and are still in unreleased change requests. If the test is successful, the change requests are transported into the PROD client. The PROD client is completely separate from the other clients as regards to cross-client data.

If you need other clients with additional roles, you can set them up in one of the three systems. Set up the development test client (TEST) and the prototype client (SAND) in the development system. Set up the training client (TRNG) in the quality assurance system.

## Two-system landscape

A two-system landscape is an alternative for smaller SAP implementations where little Workbench development takes place. The two-system landscape does not include a separate quality assurance system (QAS0). The quality assurance client is also in the development system (DEV). Figure 2-12 shows a two-system landscape.

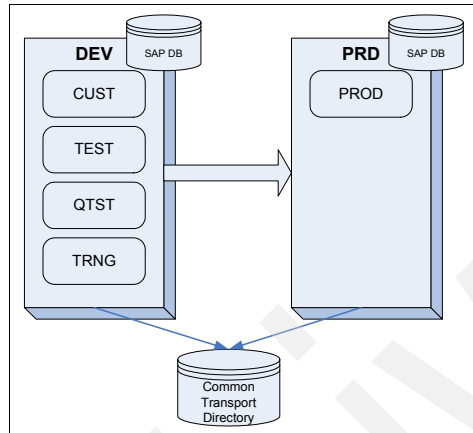

Figure 2-12 Two-system landscape

## One-system landscape

We do not recommend a one-system landscape containing all central clients in a single SAP system. Joint usage of hardware resources and cross-client data places serious restrictions on how a single system operates. In particular, once the system is used in production, you can no longer develop in it, unless you stop production operations for the development and test phases.

### 2.6.3 Change management in the SAP system landscape

Before you can use the SAP software to control the business processes in your company, you must first adapt it to your own business needs. This is usually done in an SAP implementation project. Adapting and configuring is usually an ongoing process. Even after you start using the system in a production environment, you still need to make changes to the SAP configuration. This may be due to business or organizational changes in your company, or due to the implementation of new SAP functions. This is often linked to an upgrade to a new SAP Release.

SAP provides various tools for modifying the SAP software. Which tools you use depends on the type and extent of your business requirements. Any modifications that you make with these tools are stored in certain tables in the SAP database.

## 2.7 SAP database

This section discusses SAP databases. The discussion includes the following sections:

- ▶ 2.7.1, “Supported databases” on page 35
- ▶ 2.7.2, “Database administration facilities” on page 35
- ▶ 2.7.3, “Connectivity and integration” on page 36

### 2.7.1 Supported databases

SAP supports the following databases:

- ▶ Oracle
- ▶ MS® SQL Server
- ▶ IBM DB2 Universal Database™ for UNIX and Windows
- ▶ SAP liveCache technology
- ▶ MaxDB
- ▶ IBM DB2 Universal Database for z/OS®
- ▶ IBM DB2 Universal Database for iSeries®
- ▶ IBM Informix®

More database and operating system support information can be found in the Product Availability Matrix (PAM) on SAP Service Marketplace. A login is required to access SAP Service Marketplace, which can be found at the following address:

<http://service.sap.com/pam>

### 2.7.2 Database administration facilities

SAP NetWeaver enables you to manage your database using the Computing Center Management System (CCMS). With CCMS, you get extensive support in database administration (DBA) and can perform many DBA functions from SAP NetWeaver.

SAP recommends that you use CCMS for database administration where possible. The advantage of using CCMS is that you have a central point for managing your database. You also get the full advantage of the SAP NetWeaver graphical user interface (GUI), for example, when displaying space usage in your database.

The CCMS is a standard part of SAP NetWeaver. You can therefore use it for your database administration activities.

The most important DBA functions in CCMS are as follows:

- ▶ DBA planning calendar
- ▶ Statistics updates using the cost-based optimizer
- ▶ Database system checks
- ▶ Database monitor
- ▶ Database alert monitor

The functions and appearances differ slightly for different database platforms. You must perform certain DBA functions outside SAP NetWeaver with the tool provided by the database vendor or developed by SAP for each database (for example, for offline backups of the database). An example of a DBA tool outside SAP NetWeaver is BR\*TOOLS, available for Oracle databases.

### 2.7.3 Connectivity and integration

This section explains the mechanism used by SAP systems to connect to the databases. The connections discussed are for:

- ▶ “ABAP application server” on page 36
- ▶ “Java application server” on page 38
- ▶ “Data mapping and schemas” on page 38

#### **ABAP application server**

Figure 2-13 on page 37 provides an overview of how an SAP application server for ABAP connects to the database.



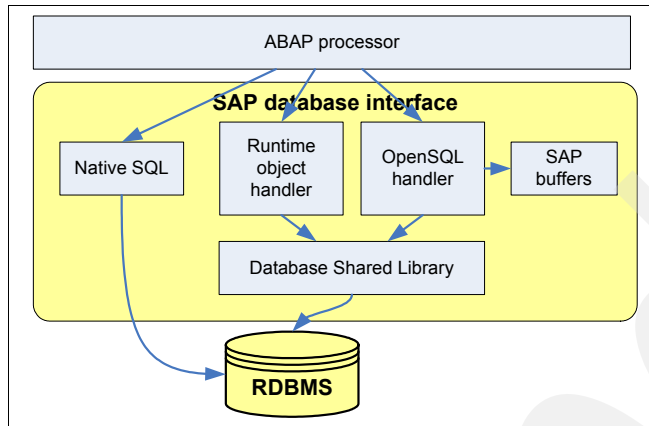

Figure 2-13 SAP NetWeaver ABAP application server database access

The ABAP language offers the following options to communicate with the database:

- ▶ OpenSQL for ABAP, SAP's database-independent SQL dialect that is used by most standard SAP applications
- ▶ Native SQL, which is database-dependent

The ABAP processor uses a database interface to connect to the database. The database interface provides a database platform abstraction layer and translates all Open SQL statements from the ABAP processor into native database-specific SQL statements.

The database interface also performs the database platform-specific type mapping between ABAP data types and database data types. Each database platform provides a platform specific database shared library (DBSL) interface. The DBSL is part of the SAP kernel and developed in C.

The DBSL shared library for DB2 on Linux, UNIX, and Windows (dbdb6slib.\*) uses the DB2 Call Level Interface (CLI) to communicate with the DB2. This means that the DBSL shared library dynamically loads the DB2 client libraries.

## Java application server

Figure 2-14 provides an overview of how the Java application server connects to the database.

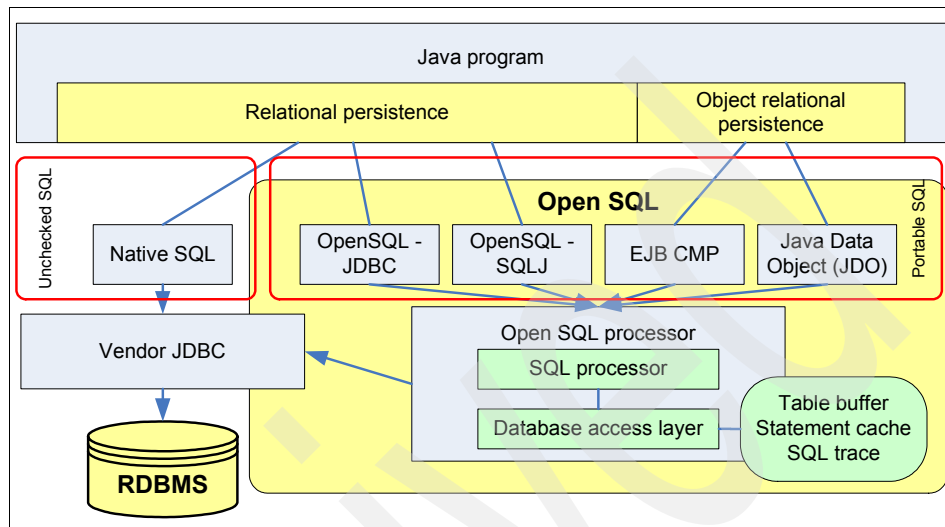

Figure 2-14 Java application server database access

Java programs that run inside the SAP application server Java can use various standardized APIs to access the database, for example, JDO, SQLJ, or JPA. The database interface offers Java applications the following options to communicate with the database:

- ▶ OpenSQL for Java, SAP's database-independent SQL dialect
- ▶ Native SQL, which is database-specific

The SAP application server for Java uses various services that assist in the communication with the DBMS (for example, the dbpool service for database connection pooling, which is not shown in Figure 2-14).

All communication with the DBMS is done using the IBM DB2 Driver for JDBC™ and SQLJ, which is a pure Java Type 4 JDBC driver that is based on distributed relational database architecture (DRDA®) and uses TCP/IP as the network protocol.

## Data mapping and schemas

The application data of an SAP system is stored in database tables. Other database objects that are used by the SAP system are views and indexes. The database maintains a catalog with all existing database objects called the system catalog. A similar catalog is maintained in the SAP system. This can either be the

ABAP Dictionary or the Java Dictionary, or both, in case of an ABAP+Java SAP system. Figure 2-15 shows the relation between SAP application objects and database objects.

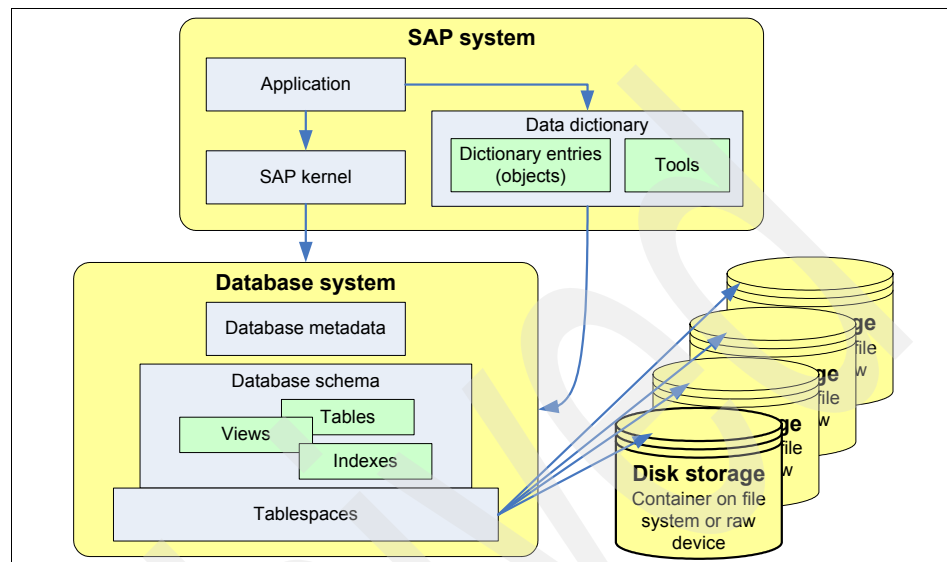

Figure 2-15 Database objects in SAP

Each SAP system corresponds to one database instance. Database schemas are used to group the database objects of the AS Java and AS ABAP. The relation between the database of the SAP system and the database schema is as follows:

- ▶ SAP ABAP-only system: One database with one schema named by default sap<sapsid>
- ▶ SAP Java-only system: One database with one schema named by default sap<sapsid>db
- ▶ SAP ABAP+Java system: One database with two schemas, that is, sap<sapsid> for the ABAP objects and sap<sapsid>db for the Java objects

## 2.8 References

For more information about the topics in this chapter, you can go to the SAP help page found at the following address:

[http://help.sap.com/saphelp\\_erp60\\_sp/helpdata/en/6a/44b2420e71c511e100000a1550b0/frameset.htm](http://help.sap.com/saphelp_erp60_sp/helpdata/en/6a/44b2420e71c511e100000a1550b0/frameset.htm)

Archived

# SAP data protection considerations

In this chapter, we take a closer look at the data protection needs and considerations for SAP systems. The discussion includes:

- ▶ 3.1, “Strategic view of data protection” on page 42
- ▶ 3.2, “Protection of SAP data” on page 49
- ▶ 3.3, “Database backup types and considerations” on page 61
- ▶ 3.4, “Data protection and data retention” on page 68
- ▶ 3.5, “Tivoli Storage Manager and the SAP landscape” on page 69
- ▶ 3.6, “High availability” on page 76
- ▶ 3.7, “Backup scheduling considerations” on page 82

## 3.1 Strategic view of data protection

Enterprise data is viewed as a strategic asset. The loss of data can disrupt business functions and destroy business value. In many cases, significant data loss will lead to lost business. Therefore, data and information need to be managed and protected (as well as other types of enterprise assets). There are some methodologies that deal with the best practices for the management of information and data protection, such as IT Infrastructure Library® (ITIL) or Control Objectives for Information and related Technology (COBIT).

The Storage Networking Industry Association (SNIA) methodology of information lifecycle management has also been adopted by many vendors, including IBM. The purpose of information lifecycle management is to provide policies, processes, practices, services, and tools that are used to align the business value of information with the most appropriate and cost-effective infrastructure from the time information is created through its final disposition.

The company's strategic requirements for data protection should be specified by the business continuity planning project known as the *business continuity plan*. The business continuity plan reflects what is really important for management in running the business and which components are critical to perform the business operations after a disaster occurs.

For data protection and data availability projects, the important parts of the business continuity plan are risk analysis and business impact analysis.

Planning for data protection requires answering many questions, such as:

- ▶ What threats should the information systems be protected against?
- ▶ What are the systems that need to be protected?
- ▶ Does the production system need a high availability solution?
- ▶ How many versions of the databases should be kept in the backup storage?
- ▶ Do we need to spend money on LAN-free backup?
- ▶ What data has to be archived because of legal requirements?

Our answers should be provided by the risk analysis and the business impact analysis (BIA).

- ▶ The risk analysis identifies the threats that could cause financial or operational impact to the organization. It evaluates the probability of the event occurrences. This process also assesses the existing state of the protection against threats and identifies the vulnerabilities of the organization to those threats.

- ▶ The business impact analysis analyzes the business functions within the company and the impact of specific failures on the continuity of the business processes. Business impact analysis tracks the critical business processes and also identifies the computer systems, applications, and data that are required to support these processes.

The outcome of business impact analysis quantifies the potential impact of a failure or disaster on the computer systems in business terms (such as the estimated duration of the business function unavailability due to a certain failure) and also in monetary terms (such as the cost per hour of the unavailability of the business process, and the cost of data recreation in case of storage device failure). Business impact analysis should also specify the intangible impacts of business processes unavailability, such as a loss of market position or loss of customers.

The analysis of the risk and business impact of an application's downtime provides the basis to determine the important data classes within the company and the minimal level of service level for protection, availability, and confidentiality that the data classes requires. In case of data protection and data availability, the service levels can be expressed by metrics recovery time objective (RTO) and recovery point objective (RPO). These measurements are discussed in 3.1.1, "Measuring data availability and protection service levels" on page 44.

The higher level of data protection that you want to achieve, the higher the cost of the data protection technology will be. Thus, selecting an appropriate data protection strategy involves balancing the cost of the solution against the business impact of an unplanned application downtime. Generally, the cost of the data protection (data availability) should not exceed the loss sustained in the event of business process disruption caused by the loss of the data.

As the business value of the applications varies, certain types of data require higher network throughput and better security and protection than other data types. The BIA helps distinguish the data classes within the company according to their business importance. It should also define the required level of protection against potential threats. Each group of data should be assigned an appropriate service level from the supporting infrastructure according to their business importance.

By applying data classification during the analysis phase of the data protection project, you can achieve effective and efficient usage of storage technologies, as it reduces the number of situations where the less critical data is stored on a very expensive data storage that is dedicated to mission critical data.

### 3.1.1 Measuring data availability and protection service levels

The service level, in terms of data availability and recoverability, can be specified by the measurable parameters recovery time objective (RTO) and recovery point objective (RPO), the annual uptime, and some additional supporting metrics.

The metrics RPO and RTO for the particular application or a group of data should be obtained as a result of the business impact analysis. The metrics are used to specify the required quality data protection services in a measurable way. The metrics are used as a base input for the backup/high availability solution design. When designing the data protection solution, the RTO and RPO, together with other measurable characteristics, help the architect to select the technologies that will ensure that the solution meets the criteria.

The following parameters are used to specify the level of service for data recoverability and data availability:

- ▶ **Recovery Time Objective (RTO):** The maximum tolerable application downtime. In other words, how long can it take to restore/recover the data of an application. The RTO together with the data size helps determine the data protection technology, which can recover the given volume of data within the given time.
- ▶ **Recovery Point Objective (RPO):** The maximum amount of data loss that can be tolerated in the event of a failure. In other words, the maximum amount of time between the data protection events (the frequency of backup).
- ▶ **Required Annual Uptime:** This parameter specifies the maximum tolerable percentage of unscheduled downtime per year (that is, 99,999% or 99.99%). A year is considered to be 525960 minutes. This parameter assists the architect with decision making, and whether to implement a high availability solution, such as HACMP, or use the rapid backup/recovery techniques, such as FlashCopy/FlashBack.

**Note:** When designing the data protection solution, the RPO and RTO metrics may be different for the operation recovery and disaster recovery solution design.

- ▶ The RPO metrics for the operation recovery solution specifies the frequency that data is replicated to the local backup storage (incremental backup and backup of offline redo logs).
- ▶ For disaster recovery solutions, RPO stands for the frequency that the backup data is moved to an offsite locality.



While designing the data protection solution, RTO and RPO are not the only parameters you need to consider. To select an appropriate backup or high availability technology and to be able to provide the appropriate solution sizing, you have also take into account the other supportive criteria, such as:

- ▶ **The data size:** The size of the data to be protected is one of the most critical pieces of information required for the solution design. The combination of the RTO, RPO, and the data size helps you to determine if a given technology is sufficient enough to recover the given volume of data in the given time. In terms of backup technologies, if you know RTO and the size of backup data, you will be able to specify the minimal throughput for the data transfers during the restore operations.
- ▶ **Data type:** To design the appropriate data protection strategy, it is necessary to know the types of data that are going to be protected. Typically, the operation system binary files are backed by different techniques than the database data files.
- ▶ **Future data growth:** The estimate of the future growth of the data size allows the architect to choose the technology (that is, storage, networks or HA solutions) that will provide an appropriate scalability to support future data protection needs.
- ▶ **Backup retention requirements:** This required data retention, together with the RPO, RTO, and data size, is used to calculate the capacity required for the backup storage. Data retention is expressed usually by the number of backup versions or by the number of days the versions have to be retained.
- ▶ **Recovery Object Granularity (ROG):** Specifies the level of objects that the solution is able to backup/recover (that is, volume, file system, database, tablespace, and so on).
- ▶ **Data Protection Window (DPW):** The maximum available time during which a system can be suspended and the data can be copied to the backup media. Certain data protection techniques are more disruptive to the application than others. For example, the database is inaccessible to applications for the whole duration of an offline backup. Therefore, this type of backup is not suitable for the applications with low DPW values. On the other hand, online backup or FlashCopy techniques are suitable for this type of applications.
- ▶ **Recovery Time Granularity (RTG):** Specifies the frequency of the points of recovery. In other words, RTG stands for the frequency of backup events.

**Note:** The metrics described above can are used to express the service level required by the applications from data protection solutions. The RPO, RTO, and annual uptime metrics are frequently used in Service Level Agreements as benchmarks for the outsourced IT services.

Let us look at a sample situation. A customer requires a backup solution design. The technology must protect the DB2 database against media failures and user failures. The protection against disaster events is not required. The customer requires the parameters described in Table 3-1.

*Table 3-1 Recovery parameter requirement*

Parameter	Required value
Recovery Time Objective (RTO)	6 hours
Recovery Point Objective (RPO)	2 hours
Data size	500 GB
Backup retention	30 days
Data type	Database DB2
Recovery Object Granularity (ROG)	Database
Recovery Time Granularity (RTG)	Any point in time within the last 30 days
Data Protection Window (DPW)	0

Analyzing the data in Table 3-1, we find that:

- ▶ A backup/restore technology can protect the customer's data against media failure and user errors. As the required speed of recovery (RTO) is not extremely low, we do not have to consider a high availability solution in addition to backup.
- ▶ In case of failure, 500 GB volume of data has to be restored within 6 hours (RTO). This means that we have to use a technology that has a restore throughput at least 50 MBps (storage, networks, and processor). We also have to take into the account that after the full backup image is restored, some redo logs must be restored and applied.
- ▶ To minimize the recovery time, we have to reduce the time taken by the roll-forward operation (applying the redo logs after the full backup restore). Therefore, we suggest scheduling a daily full backup. Thus, in the worst case, we must restore and apply only the redo log files generated within the last 24 hours.
- ▶ The backup operation must not disrupt the application (DPW=0), therefore the DB2 daily full backup will be taken online.
- ▶ The maximum data loss set by the RPO parameter is 2 hours. It means that the company can afford to lose 2 hours or less of work performed before the failure occurred. Therefore, the solution must guarantee that the last redo log backup was performed in less than two hours before the failure. We consider using the DB2 log manager to back up offline log files directly to Tivoli

Storage Manager server. The log manager backs up the log right after it becomes offline. Therefore, this solution guarantees that the RPO requirement will be met.

- ▶ If we consider the full backup to be taken every day and that the required data retention is 30 days, the required capacity of the backup storage will be 500 GB x 30 = roughly 15 TB. We also have to consider that we will have to store all the offline redo logs generated within the last month (because of the point in time restore requirements). It can be as much as 3 to 5 GB depending on the number of transaction performed on the database. Thus, the total required space on the backup media can be as much as 20 TB.
- ▶ We plan to use LTO4 tapes as our backup media (1600 GB maximum capacity with compression enabled with 160 MBps of throughput and no compression). The tapes should be replicated so that the backup data is protected against the backup media failures. Therefore, the total required capacity on backup tapes is doubled (20 TB x 2 = 40 TB). We can also estimate that the storage capacity required for the DB2 backup would be around 25 LTO4 tapes (40 TB divided by 1.6 TB LTO4).

If necessary, the required backup storage capacity could be reduced by employing full, incremental, or differential DB2 backups.

### 3.1.2 Failure types

The specification of the potential threats that can cause application downtime or data loss can be found by the business impact analysis. The business impact analysis should evaluate the potential causes of the application disruptions.

When designing the data protection solution, you have to consider the techniques that can recover the application with respect to the cause of the damage of data. This chapter provides an overview of the most common general types of database failures that may lead to an application disruption or data loss. This chapter also discusses ways to correct or eliminate those failures.

During the operation of the database, different kinds of errors may occur. The following failures may affect the availability of data and require the intervention of a database administrator, but most likely will not cause a data loss:

- ▶ Instance failure
- ▶ Network failure
- ▶ Process failure (failure of the database background processes)
- ▶ Statement failure (failure of a statement execution because of, for example, incorrect command syntax)

Additional types of errors require the administrator's intervention and restore or recovery of the data from backup:

- ▶ "User errors" on page 48
- ▶ "Media errors" on page 48
- ▶ "Disaster events" on page 49

## User errors

A user error includes the errors caused by human or a malfunctioning application. Typically, a user or application makes undesired changes to the data, such as deleting the contents of the database table or unwanted editing of a file. Such errors can be corrected if the deleted table or file has been backed up prior to deletion or the undesired change. This backup can be used to restore the condition of the object at the time of the error.

**Note:** Oracle Database since Version 10g supports the FlashBack database function. This function can return the state of the entire database to a point in time in the past. Traditionally, this could be achieved only by restore and recovery.

Recovery from user errors is restricted to a point prior to the user error and all database changes made subsequent to the error are lost. None of the mechanisms designed to protect data and provide availability, as described in this book, will provide recovery to a point after the user error. Therefore, it is of paramount importance to train users and implement proper user security procedures in order to prevent user errors.

The data replication solutions that do not support versioning or asynchronous replication cannot protect the application data against user errors because the user error is replicated to other replicas of data as well.

In general, the database specific export/import tools cannot be used to recover a lost SAP object. The reason for this is that the SAP database tables are often shared system-wide, and an import of such a table would risk overwriting the work of other users.

## Media errors

A media error occurs when an external problem prevents the application from reading from or writing to data files. A typical example is a hard drive or network error. Media failures fall into two general categories: permanent and temporary.

- ▶ Permanent media failures are serious hardware problems that cause the permanent loss of data on the disk. Lost data cannot be recovered except by repairing or replacing the failed storage device and restoring backups of the files stored on the damaged storage device.

- ▶ Temporary media errors are hardware problems that make data temporarily inaccessible; they do not corrupt the data. For example, a disk controller failure necessitates replacement of the disk controller, after which the data on the disk can be accessed. Another example of a temporary failure is a power failure on the SAN switch. When power is returned, the storage device and all associated data is accessible again.

In general, the impact of media failure may be reduced by storage media duplication, such as LVM mirroring or a RAID setup. Also, the high availability (HA) solutions are suitable for recovery from media failures, such as HACMP or Oracle DataGuard. The HA solutions support a complete, redundant environment, including servers, networks, and storage. The HA enables the application to be moved automatically from a failing node to an intact node. If the HA is implemented, the disruption caused by a media failure can be reduced to seconds.

### **Disaster events**

A disaster is any kind of natural disaster situation that can destroy or substantially damage the entire primary data center. The typical examples are floods or fires. A disaster can be considered a special type of permanent media failure that affects the whole data center, including the local storage systems, network connectivity, and even the local backup media. Only the backup or data replication to an offsite location can help reduce the impact of this threat. The distance between the primary data center and the offsite location has to be carefully considered with respect to all the potential threats.

Depending on the required RPO and RTO values for disaster recovery, you can replicate data to an offsite location by:

- ▶ Periodically moving the backup replicas to the offsite locality (offsite vaulting).
- ▶ Transfer the backup data directly to the remote backup system through the network.
- ▶ Implement a high availability solution with a remote mirror, such as HACMP-XD with Metro Mirror or database log shipping.

## **3.2 Protection of SAP data**

Data protection of the SAP server involves steps to protect of all the software components that are needed by the SAP system to operate. The base components of the SAP server are the operating system, the SAP application server, database instance, and data files. Each component requires different data protection techniques.

For example, you have to consider a bare machine recovery of the operating system will be required. Also, you have to consider if you need an operating system backup tool that supports restore of the operating system to a different platform (for example, the restore of a system backup of Windows 2003 from an HP machine to an IBM machine). A backup of the operating system can usually be taken online.

If you plan for the protection of an SAP application server, you have to consider the type and the frequency of the backup of the file systems. The backup of the binaries of the SAP application server can be taken by a file system backup using the Tivoli Storage Manager Backup Archive Client or similar application. You should also consider the level of the file system backup (image backup or file level backup).

The SAP system uses the relational database as a main storage for all SAP data and meta information. This main storage is the basis for the tight integration of all SAP application modules and guarantees consistent data storage. Data in the SAP database is unique for every company and if the data is lost, it cannot be just reinstalled in the same way as the operating system. Therefore, it is important to take special care when planning the protection of the data stored in the SAP database.

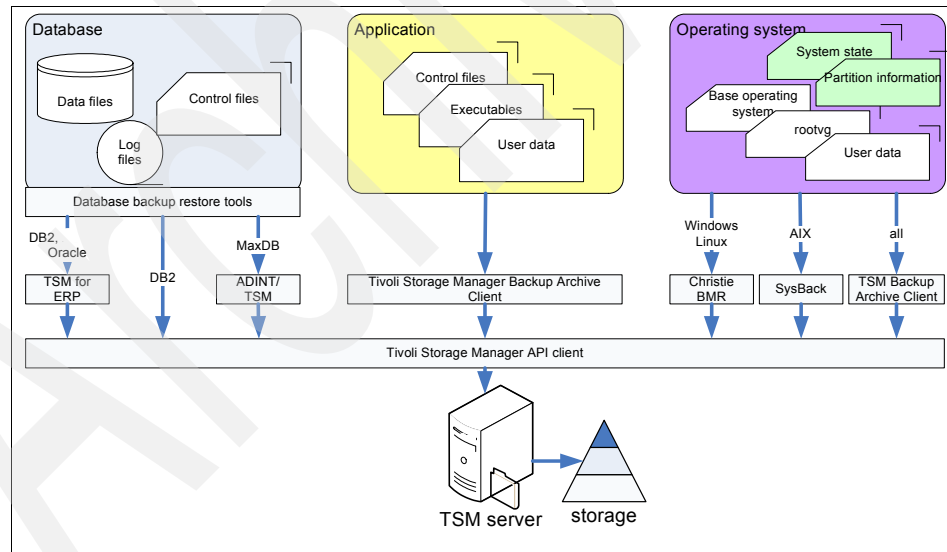

Figure 3-1 Overview of SAP data protection

We discuss each type of protection in the following sections:

- ▶ 3.2.1, “Protection of the operating system” on page 51
- ▶ 3.2.2, “Protection of SAP file systems data” on page 51
- ▶ 3.2.3, “Protection of the SAP database” on page 53

### 3.2.1 Protection of the operating system

The backup of the operating system is the important part of SAP data protection. If the backup of the operating system is performed correctly, it can eliminate the need for the reinstallation and setup of the operating system, device drivers, and application software in case there is a corruption of the operating system.

The backup of the operating system should be performed on a regular basis at least once every 14 days or after major changes have been made in the operating system configuration, such as an operating system upgrade or installing a patch.

In the Windows based operating system, Windows Backup or Tivoli Storage Manager Backup Archive Client can provide a basic data protection facility. Both of these backup tools can back up binaries of the operating system and application software as well as the Windows system state. Thus, it is possible to restore the operating system to the state where it was when the backup was taken. You can also use some advanced backup tools specifically designed for operating system restore, such as Christie Bare Machine Recovery, which allows a heterogeneous restore of the operating system.

AIX provides a built-in operating system backup tool called `mksysb`. The `mksysb` command creates a backup of the root volume group on which the operating system is installed. You can use this backup to reinstall a system to its original state after it has been corrupted. If you create the system backup on tape, the tape is bootable and includes the installation programs needed to install from the backup.

### 3.2.2 Protection of SAP file systems data

SAP non-database file systems contain various files necessary for SAP system operation. The non-database files include SAP executables, transport files, diagnostic agent global scripts, profiles, and so on.

SAP file systems can be considered to be:

► Permanent files

You can find these files on UNIX systems in the subdirectories `/usr/sap/<SAPSID>/SYS` and the database installation and database home directories. They include executable programs and profiles of the SAP system and of the database system. We recommend you back up the SAP directories after any SAP system upgrade and the database directories after a database software update.

► Temporary files

You can find these files, on UNIX systems, in the subdirectory `/usr/sap/<SAPSID>/<INSTANCE>`. The loss of these files is not critical, and does not cause data inconsistency. SAP provides tools that can reset the references to these files in the database, when required.

All the file systems that need to be backed up to protect SAP application server are specified in Table 3-2.

Table 3-2 SAP application server file systems

File system	Description	Backup tool
<code>/sapmnt/&lt;SID&gt;</code>	Software and data for one SAP system.	File System Backup (Tivoli Storage Manager backup archive client)
<code>/usr/sap/&lt;SID&gt;</code>	Instance-specific data with symbolic links to the data for one system.	File System Backup (Tivoli Storage Manager backup archive client)
<code>/usr/sap/trans</code>	Global transport directory for all SAP systems.	File System Backup (Tivoli Storage Manager backup archive client)
<code>/usr/sap/&lt;SID&gt;/&lt;instance_number&gt;</code>	Instance-specific data of the Diagnostics Agent.	File System Backup (Tivoli Storage Manager backup archive client)
<code>/usr/sap/&lt;SID&gt;/SYS/profile</code>	Contains the profiles of the Diagnostics Agent instance.	File System Backup (Tivoli Storage Manager backup archive client)
<code>/usr/sap/&lt;SID&gt;/exe</code>	Contains global scripts for the Diagnostics Agent.	File System Backup (Tivoli Storage Manager backup archive client)

The file systems shown in Table 3-2 are not database related. They are backed up as a part of the file system level backup. In case Tivoli Storage Manager Backup Archive Client is used for the file systems backup, those file systems should be included in daily incremental file systems backup. A weekly image backup of the file systems on the production servers should be considered to enhance the speed of the restore operation.



In the case of a bare machine recovery or disaster recovery, these file systems have to be restored from backup as soon as the recovery of the operating system is accomplished. After recovering the SAP file systems, you can start restoring the database.

**Note:** The database should be backed up by the database specific backup/restore tool provided by the relational database system. It is necessary to exclude the database data and index files from daily incremental backup.

### 3.2.3 Protection of the SAP database

The protection of the SAP database has two parts: protecting the database binaries and configuration files and protecting data stored in the data files. Database binaries and configuration files are likely backed up as part of the operating system or file system backup.

The backup of the database data files and other supporting structures associated with SAP data should be made by a dedicated tool designed especially for the database backup. Database backup/restore tools are capable of performing backup and restore data in a consistent state. The backup tools can also perform an online backup of the database and backup of redo log files right after the log files were archived.

Without a careful approach to backing up your database, you run the risk of experiencing excessive system downtime and possibly losing data. Data loss and can be caused by the following reasons:

- ▶ By external factors or physical errors

You must recover the database up to the point in time when the database crashed. If a full recovery is possible, only the data of uncommitted transactions before the error is lost.

- ▶ By logical errors

You must recover the database up to a point in time shortly before the error occurred. However, data entered after the error is lost.

To avoid data loss after a logical error, it is sometimes possible to restore the database to a different machine and then export the affected table from that machine to your production database. However, this method is difficult and requires expert knowledge of the application that uses the table.

In relational database system, apart from regularly backing up the database, you also need to archive the redo log files. Redo log files contains notes on what data is changed in the database. You use the redo log files to re-apply the data changes after the backup is taken. The concept of database forward recovery with backup and redo logs is shown in Figure 3-2.

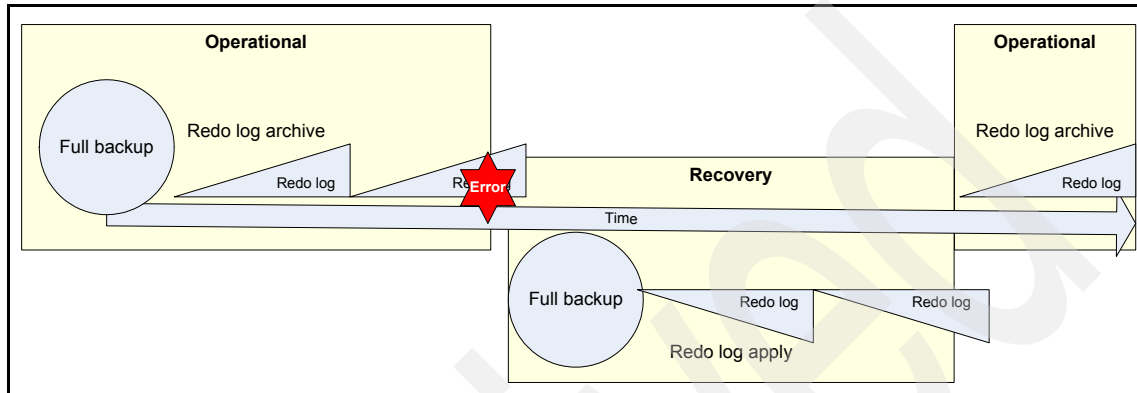

Figure 3-2 Database forward recovery

We recommend you keep at least two copies of the offline redo log files on a secure storage medium. For maximum security, store the copies in different locations.

### The database storage structures

This section explains the fundamental building blocks of a relational database management systems (RDBMS). This understanding is crucial for designing procedures to protect these database components from failure. The database structure is shown in Figure 3-3.

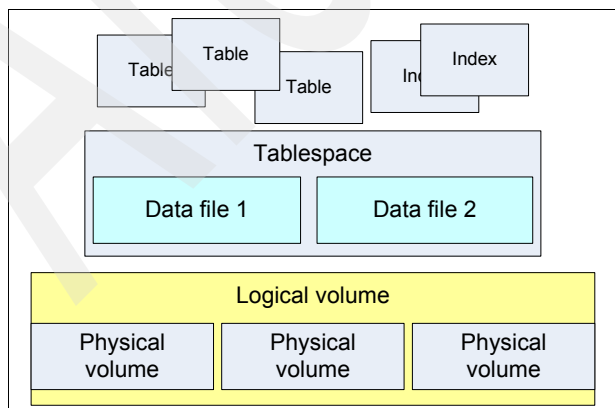

Figure 3-3 Database storage structure

Relational databases are similar in design. Tables and indexes from a database are stored in a logical entity called *tablespaces*. The tablespaces are defined as a group of physical storage (implemented as data files) that shares common properties, such as auto extend, path, and so on. A tablespace is used to group related logical structures together. For example, tablespaces commonly group all of an application's tables to simplify some administrative operations. A tablespace can be online (accessible) or offline (not accessible). A tablespace is normally online so that users can access the information within the tablespace. However, sometimes a tablespace may be taken offline to make a portion of the database unavailable while allowing normal access to the remainder of the database. This makes many administrative tasks easier to perform.

The data files that provide physical storage for the database is stored in a file system. Most UNIX environment file system storage is arranged based on logical volumes. A logical volume can span more than one physical volume. A physical volume can either be a physical hard disk or a set of physical hard disks that are viewed as one.

The combined size of a tablespace's data files is the total storage capacity of the tablespace. The combined storage capacity of a database's tablespaces is the total storage capacity of the database.

### **Database backup requirement**

The following are the main components of a relational database:

- ▶ **Data files:** Every database has one or more physical data files. A database's data files contain all the database data stored in data file blocks. The data of logical database structures such as tables and indexes is physically stored in the data files allocated for a database.

The blocks in a data file are read, as needed, during normal database operation and stored in the memory cache of the database. For example, when a user wants to access some data in a table of a database, if the requested data blocks are not already in the memory cache for the database, it is read from the appropriate data files and stored in memory. Modified or new data is not necessarily written to a data file immediately. To reduce the amount of disk access and increase performance, data is pooled in memory and the changed blocks are written to the appropriate data files all at once.

The characteristics of data files are:

- A data file can be associated with only one database.
- Database files can have certain characteristics set to allow them to automatically extend when the database runs out of space.
- One or more data files form a logical unit of database storage called a tablespace.

- ▶ Redo log files: Every database has a set of two or more log files. The primary function of the log files is to record all changes made to the data. This is done by *write ahead logging*, which means that all modifications of data are recorded to log files prior to applying. If a failure prevents the database from writing the modified data permanently to the data files, the changes can be obtained from the log and applied again. If the changes were not committed before the crash, the database is able to roll back using the logs.

Log files are critical in protecting a database against failures. To protect against a failure involving the log itself, some databases, such as Oracle, allow a multiplexed redo log so that two or more copies of the redo log can be maintained on different disks. For other databases, the disk containing log files must be mirrored to protect against failure. Log files can be broadly classified as active or archived log files. An active log file is used by the database to log transaction changes. Active logs are used by crash recovery to prevent a failure (system power or application error) from leaving a database in an inconsistent state. An archived log file is generally used for recovery to a specific point in time. Some databases like DB2 UDB further differentiate archived log files as online or offline depending on whether the archived log files are saved and moved from their default location.

The information in a log file is used only to recover the database from an instance failure or media failure that prevents database data from being written to a database's data files. For example, if an unexpected power outage abruptly terminates database operation, data in memory cannot be written to the data files and the data is lost. However, any lost data can be recovered when the database is opened after power is restored. By applying the information in the most recent log files to the database's data files, the database is restored to the time at which the power failure occurred. Log files are also used to recover from user errors, for example, accidentally deleting a table from the database.

- ▶ Control files: Most databases use a control file. A control file contains entries that specify the physical state of the database. For example, it contains the following types of information:
  - Database name
  - Names and locations of a database's data files and log files
  - Time stamp of database creation

Like the log files, the database allows for copies of the control file for protection. Every time an instance of a database is started, its control file is used to identify the database and log files that must be opened for database operation to proceed. If the physical makeup of the database is altered (for example, a new data file or log file is created), the database's control file is automatically modified by the database to reflect the change. A database's control file is also used if database recovery is necessary.

- ▶ Instance configuration files: Instance configuration files specify the information required to start the database instance. Instance configuration files may contain the following information:
  - The database memory structure sizing
  - The network communication of database
  - The location of control files

Most of the database backup/restore tools can back up the instance configuration files together with the control files.

Table 3-3 provides the information about the directory structure of SAP databases and the type of backup that can be used when implementing Tivoli Storage Manager backup. Some of the directories can automatically backed up by the Database backup tools and some directories need to be backed up by a file system backup tool, such as Tivoli Storage Manager Backup Archive Client.

Table 3-3 SAP databases file system backup

File system/Logical volume	Description	Backup tool
<b>DB2 file systems</b>		
/db2/db2<sid>	Home directory of user db2<dbsid>. Contains the DB2 instance data for <DBSID>.	File System Backup (Tivoli Storage Manager backup archive client)
/db2/<SID>/db2dump	Contains DB2 diagnostic log files, DB2 dump files, and further service engineer information.	File System Backup (Tivoli Storage Manager backup archive client)
/db2/<SID>/log_dir	Contains at least the online database log files.	Database Backup (DB2 Backup), exclude from FS backup
/db2/<SID>/sapdata<n>	SAP data.	Database Backup (DB2 Backup), exclude from FS backup
<b>Oracle file systems</b>		
/oracle	Oracle base directory	File System Backup (Tivoli Storage Manager backup archive client)
/oracle/client	File system for Oracle client software.	File System Backup (Tivoli Storage Manager backup archive client)
/oracle/stage/102_64	Installation and upgrade directory for database software (staging area).	File System Backup (Tivoli Storage Manager backup archive client)
/oracle/<SID>	Home directory of user ora<dbsid>.	File System Backup (Tivoli Storage Manager backup archive client)

File system/Logical volume	Description	Backup tool
/oracle/<SID>/102_64	Home directory for Oracle instance <DBSID> (<ORACLE_HOME>).	File System Backup (Tivoli Storage Manager backup archive client)
/oracle/<SID>/origlogA	Original set A of redo logs.	Database Backup (BR*Tools), exclude from FS backup
/oracle/<SID>/origlogB	Original set B of redo logs.	Database Backup (BR*Tools), exclude from FS backup
/oracle/<SID>/mirrlogA	Mirrored set A of redo logs.	Database Backup (BR*Tools), exclude from FS backup
/oracle/<SID>/mirrlogB	Mirrored set B of redo logs.	Database Backup (BR*Tools), exclude from FS backup
/oracle/<SID>/oraarch	New standard backup file system for Oracle offline redo logs.	Database Backup (BR*Tools), exclude from FS backup
/oracle/<SID>/saparch	BR*Backup log files.	File System Backup (Tivoli Storage Manager backup archive client)
/oracle/<SID>/sapreorg	Working directory for database administration.	File System Backup (Tivoli Storage Manager backup archive client)
/oracle/<SID>/sapdata<n>	SAP data.	Database Backup (BR*Tools), exclude from FS backup
<b>MaxDB file systems</b>		
/sapdb/<SID>/sapdata	SAP MaxDB data.	Database Backup (MaxDB), exclude from FS backup
/sapdb/<SID>/sapdblog	SAP MaxDB redologs.	Database Backup (MaxDB), exclude from FS backup
/sapdb/<SID>/sapdb	SAP MaxDB software.	File System Backup (Tivoli Storage Manager backup archive client)

**Note:** BR\*Tools logs are stored in the directory /oracle/<SID>/saparch. BRBACKUP automatically backs up the logs and profiles after every backup operation. In the case of bare metal restore or disaster recovery, logs and profiles must be restored to enable BR\*Tools to restore data files. The process may be simplified if the logs and profiles are backed up by Tivoli Storage Manager backup archive client during the file system backup.

## 3.2.4 Include exclude options

Tivoli Storage Manager server can define include-exclude options using the `inclexcl` parameter in a client option set. The include-exclude statements specified by the server are evaluated along with those in `dsm.sys`, the client system options file.

The server include-exclude statements are always enforced and placed at the bottom of the include-exclude list and evaluated before the client include-exclude statements. The include-exclude list is *always* read from the bottom to the top.

When performing backup, Tivoli Storage Manager performs the following sequence:

1. Tivoli Storage Manager evaluates all `exclude.fs` and `exclude.dir` statements, and removes the excluded file spaces, directories, and files from the list of objects available for processing.
2. Tivoli Storage Manager evaluates the include-exclude statements for controlling symbolic link processing: `exclude.attribute.symlink` or `include.attribute.symlink`.
3. Tivoli Storage Manager evaluates the remaining include-exclude list from the bottom up and stops when it finds an include or exclude statement that matches the file it is processing.
4. If a match is not found, files are implicitly included and backed up.
5. When a file is backed up, it is bound to the default management class unless it matched an include statement that specified a different management class name, in which case the file is bound to that management class.

**Note:** A very large include-exclude list may decrease backup performance. Use wildcards and eliminate unnecessary include statements to keep the list as short as possible.

### Include options

The include options can be one of the following:

- ▶ Objects within a broad group of excluded objects that you want to include for backup, archive, image, and space management services
- ▶ Objects to which you want to assign a specific management class
- ▶ Default management class for all objects that are not explicitly assigned to a management class
- ▶ Files that are included for backup or archive processing with encryption
- ▶ Files that are included for backup or archive processing with compression

If you do not assign a specific management class to objects, Tivoli Storage Manager uses the default management class in the active policy set of your policy domain.

Use the **query mgmtclass** command to display information about the management classes available in your active policy set.

### Exclude options

The exclude options exclude objects from backup, image, or archive services. For example, you might want to exclude all temporary files, any local caches of network files, all files that contain compiled object code that you can easily reproduce using other methods, or your operating system files. You can exclude specific files from encryption processing during a backup. When you exclude a file that was previously included, existing backup versions become inactive during the next incremental backup.

The server can define exclude options with the `inclexcl` option. Exclude any system files or images that could corrupt the operating system when recovered. You should also exclude Tivoli Storage Manager client directory containing the client files.

### Recommended include exclude options

In order to use the parameters of `exclude/include list`, make sure to have the parameter `inclexcl` set on your `dsm.sys` file.

We recommend that you exclude the following from your include exclude list:

- ▶ System files that may corrupt the operating system if restored
- ▶ Database data and index files that must be handled through DB2

Example 3-1 shows an example minimal exclude list.

#### *Example 3-1 Minimal exclude list*

---

```
exclude /unix/  
exclude.dir /unix/  
exclude ../../core
```

---

For an SAP environment, you want to exclude database data files and archive logs. These data files and archive logs can be backed up with a separate utility.

A sample exclude list for Oracle is shown in Example 3-2 on page 61.



*Example 3-2 Exclude list for Oracle*

---

```
exclude "/oracle/.../sapdata?/.../*"  
exclude "/oracle/.../oraarch/.../*"  
exclude "/oracle/.../mirrlog?/.../*"  
exclude "/oracle/.../origlog?/.../*"  
exclude "/oracle/.../sapreorg/.../*"
```

---

A sample exclude list for DB2 is shown in Example 3-3. It assumes qas is the instance owner.

*Example 3-3 Exclude list for DB2*

---

```
exclude "/qas/.../*"
```

---

## 3.3 Database backup types and considerations

This section goes into more detail about database backup types. The discussion includes:

- ▶ 3.3.1, “Backup modes” on page 61
- ▶ 3.3.2, “Backup types” on page 63
- ▶ 3.3.3, “Backup cycles” on page 65
- ▶ 3.3.4, “Backup policy” on page 66
- ▶ 3.3.5, “Retention period and tape release” on page 67

### 3.3.1 Backup modes

A backup of a database creates a copy of the database's data files, control files, and, optionally, log files, and stores them on a backup media. The backup can be a consistent or inconsistent backup.

- ▶ A consistent backup, or also called an offline backup or cold backup, is a backup of all the data files in the database taken when all interim changes have been physically written to the data files, not partial changes from the log files that have not been written to the data files. If you restore a database from a consistent backup, the database will be in a consistent state as soon as the restore operation finishes.
  - For Oracle database, a consistent backup can only be taken when the database is shut down for the entire duration of the backup procedure.
  - For DB2 UDB, this means that a database must be deactivated or the instance must be stopped before the backup operation starts.

The database must stay inactive until the backup finishes. This guarantees that there are no data changes on the database at the time the backup is being taken. A consistent backup is always a backup of the entire database; it cannot be a partial or incremental backup.

**Note:** Before you shut down or deactivate the database to take an offline backup, you have to stop the SAP application servers, including the central and dialog instances. An SAP instance can be started as soon as the backup is finished. The backup script should include the stop and start instructions as follows:

```
...
su - <SID>adm -c "stopsap R3"
<database deactivation/shut down and backup commands>
su - <sapsid>adm -c startsap
...
```

You can take an offline backup by either using a dedicated database backup tool, such as Oracle Recovery Manager, BR\*Tools, the DB2 BACKUP command, or by a non-database backup tool, such as Tivoli Storage Manager backup archive client. The dedicated database backup tools guarantee that all the objects required for the successful database restore are included in the backup image. The database backup tool also guarantees that the location, time stamp, type, and other information about the backup copy is registered in the repository, such as BR\*Tools logs or a DB2 database history file. Using the meta data in the repository, backup tools can perform an automatic restore based on the specified time stamp without prompting for the backup images to restore and their location.

**Note:** A non-database backup tool can take an offline backup of a database, such as NT Backup or Tivoli Storage Manager Backup/Archive Client. You must be aware of the following items:

- ▶ You must ensure that all the files required for the successful restore are included in the backup image. It is your responsibility to include anything that is required to restore the database to a consistent state.
- ▶ These tools do not check whether anyone starts the database during the backup.
- ▶ The information about the backup image is not registered in the database tool's repository, so there is no way to make an automatic restore. The administrator has to select the sources and versions of all the backup copies that need to be restored.

- ▶ Inconsistent backup, or also called online backup or hot backup, is a backup that is taken while the database is active. The backup can be for the whole database or part of it. Changes can be performed during the backup operation. Therefore, the redo log files contain changes that have not been written to the data files. Such a backup image is not in a consistent state when it is restored, so information from redo logs must be applied to the database to achieve a consistent state (forward recovery).

**Note:** Some database backup tools provide an option that specifies that the log files required to restore and recover a database from an online backup are included in the backup:

- ▶ Oracle RMAN: **backup database plus archivelog**
- ▶ DB2: **backup database <sid> including logs**
- ▶ BR\*Tools: **BRBACKUP -backup\_type=online\_cons**

All the log files generated during an online backup are required for restoration and recovery of the database to a consistent state. Most of the database cannot run online backup if the database does not operate in archivelog mode. Archivelog mode means that redo logs are archived instead of being overwritten. The redo logs are copied to an archive directory and should be moved regularly to a backup storage.

### 3.3.2 Backup types

There are several ways to back up a database. Backup can be performed by copying physical data and log files at the file system level, or by extracting data out of the database and storing them as a set of physical files in a vendor specific format. Most databases classify backup types by the amount of data to back up, such as complete, incremental, or partial. The partial and incremental backup options are enabled only when the database operates in archivelog mode.

- ▶ Full or complete database backups

A full database backup is a backup of all data files and the control files that constitute a database.

- ▶ Incremental backups

Some backup tools allow an incremental backup, where only the changes that have been made since the last complete backup are saved. An incremental backup strategy saves memory and time and optimizes the performance of the data backup. This is of special advantage for large databases, which have few changes on a daily basis.

To be able to make an incremental backup, a reference backup called the complete backup (level 0) must be made. The complete backup (level 0) of the database backs up all database blocks that have already been used. Incremental backups can then be made. The incremental backup (level 1, cumulative) of the database backs up all database blocks that have changed since the last complete backup (level 0).

▶ Partial backups

A partial backup is a backup of part of a database. The backup of an individual tablespace's data files or the backup of a control file are examples of partial backups. A variety of partial backups can be taken to accommodate any backup strategy. For example, data files and control files can be backed up when the database is open or closed, or when a specific tablespace is online or offline.

Here are some items you must consider when choosing a backup type:

- ▶ The frequency of complete database backups should depend on the degree of activity in your database. High database activity increases the number of redo log files written between complete backups, which increases the time required for recovery.
- ▶ Performing frequent complete backups reduces the number of redo log files that must be kept in order to make a complete recovery. This reduces the data loss if one of these redo log files is lost. You can only recover up to the gap in the redo log file sequence.
- ▶ SAP recommends keeping several generations of complete backups and the corresponding redo log files. This ensures that you can still recover the database, even if the last complete backup is lost.
- ▶ Incremental backup can take the role of redo log recovery by summarizing the changes to be performed to the complete backup up to the time the incremental backup is taken. Further recovery to the current state still uses redo log recovery.

Backing up tablespaces that are changed frequently can reduce the time required for any necessary recovery. When a more recent (full or incremental) backup of an intensively used tablespace is available, fewer redo log entries have to be processed in order to recover the tablespace. If you can back up the entire database on a daily basis, tablespace backups are not necessary. You can use tablespace backup for large databases to minimize the backup impact for the whole database.

However, tablespace backups are no replacement for frequent backups of the complete database because:

- ▶ If you only perform tablespace backups for a long period of time, this increases your dependence on the archived redo log files, and therefore the risk of data loss if one of the redo log files is lost.
- ▶ If tablespace backups are used, you decide what has to be backed up. Therefore, it is possible that you might forget to back up certain tablespaces.

Another type of partial backup is to back up the control file. The control file records the physical state and structure of the database. Therefore, you should back up the control file after every structure change.

Mirrored control files protect you against the loss of a single control file. If data files are damaged, an older control file that mirrors the corresponding structure of the database may be necessary for recovery. For this reason, mirroring the control files is by no means a replacement for backing up the control file after every change in the structure of the database.

**Note:** The data of a test database might not have to be backed up as often, depending on how your test system is used. If you accept the restriction that you will only be able to recover the database from the last offline backup, you can operate the database in NOARCHIVELOG mode. If you do not back up the database at all, you must reinstall the database in a recovery situation.

### 3.3.3 Backup cycles

This section gives you recommendations about how to plan a backup cycle for your database. We recommend a backup cycle of at least 14 days, and preferably 28 days. Figure 3-4 shows the recommended 28 days backup cycle. In this case, the backup of database and logs is kept for at least 28 days.

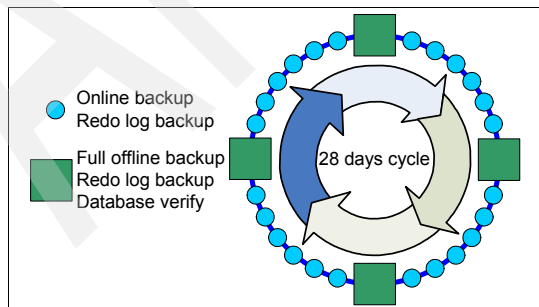

Figure 3-4 The 28 days backup cycle

The guidelines are as follows:

- ▶ Perform a full online backup each working day, or perform an incremental backup daily and then merge the existing incremental backups so the result is a cumulative incremental backup.
- ▶ Perform a full offline backup weekly (for example, during the weekend) or at least once in the cycle. The full backup would minimize the recovery time needed and the amount of redo logs to be applied in recovery.
- ▶ Back up the offline redo log files each working day and after every online and offline backup. Be sure to back up the offline redo log files twice on separate tapes.
- ▶ You must verify the backup result:
  - Verify backups for physical errors.
  - Verify the database for logical errors at least once in the cycle.
- ▶ Keep the verified full offline backup from each cycle in long-term storage, replacing it with a new initialized tape in the pool.
- ▶ Although not necessary, you can perform additional backups after changes to the database structure and keep these tapes in long-term storage. You can do this after any of the following actions:
  - A data file is added.
  - A data file is moved to a different location.
  - A tablespace is created, dropped, or reorganized.

### 3.3.4 Backup policy

The backup cycle shown in 3.3.3, “Backup cycles” on page 65 can be implemented as a backup policy. Table 3-4 shows an example of a backup policy.

Table 3-4 Sample backup policy

Backup job	Schedule	Retention period
Daily online backup	Daily at 1 a.m.	30 days
Monthly online backup	First day of month at 1 a.m.	12 months
Yearly online backup	January 1 at 1 a.m.	10 years
Transaction log backup	Daily every 30 minutes	30 days

The policies in Table 3-4 on page 66 include the following schemes:

- ▶ Daily online backup: Daily online backup is executed at a time that will not impact the business day or when some performance delay is acceptable.
- ▶ Monthly online backup: Some applications, for several reasons, require eventual restoration from time to time, such as recovery from application failure or for auditing purposes.
- ▶ Yearly online backup: Some applications, most due to audit requirements, require data retention for long periods (usually 5 to 10 years).
- ▶ Transaction log backup: The transaction log file is the most important component of the DB2 database backup. It is required to return the database to the last committed transaction. Due to the importance of this log file, we recommend implementing mirroring and taking a backup in the shortest interval possible. The backup interval should be decided according to business requirements. This interval determines how much information can be lost in the case of a log file failure (corruption or lost file).

### 3.3.5 Retention period and tape release

This task is often overlooked during implementation. After months of performing backups, the number of Tivoli Storage Manager server tapes starts to diminish. Tapes are being used for database backup and are not being reused. To avoid this kind of situation, a release procedure must be implemented from the beginning.

Database backups are usually kept for a specified time until they become obsolete. In order to manage backup storage space efficiently, these backups should then be deleted so tapes can be reclaimed. There are two ways to perform this deletion:

- ▶ Set an archive retention period using the Tivoli Storage Manager parameter RETVER.
- ▶ Use Data Protection for SAP backup version control using the MAXVERSION parameter in the ut1 file. Data Protection for SAP deletes full backups and all related redo log backups when the specified number of versions is exceeded. This is the recommended option.

**Note:** Because the SAP backup log cannot be updated by Data Protection for SAP, it may still contain old backups that are already expired.

## 3.4 Data protection and data retention

There is often some confusion between data archive and data backup. This section tries to clarify the requirements and behavior of these activities.

- ▶ A backup application takes copies of active data so they can be recovered in case the data is deleted or destroyed. Most backups are retained for a few days or weeks as later backup images supersede previous versions. Backup is a short-term insurance policy to facilitate disaster recovery.
- ▶ Archive is designed to provide ongoing access to business information. Archived records can be placed inside or outside the traditional backup cycle. Archived data is typically retained for a long period of time, often for several years, as required by legal requirements.

Backup and disaster recovery have the follow requirements:

- ▶ High media capacity
- ▶ High-performance read/write streaming
- ▶ Low storage cost per GB

Performance is an important factor for backup. Most backup operations involve large data size; the ability to quickly stream information to and from the backup media is a first priority. Fast random access to small data sets during restore operations is typically less important. As an insurance policy, it is also necessary to minimize backup expenses by reducing the cost of each stored record. The media of choice for backup and disaster recovery applications has traditionally been magnetic tape, because it satisfies the performance and cost criteria of most organizations.

The archive process has the following requirements:

- ▶ Data authenticity
- ▶ Extended media longevity
- ▶ High-performance random read access
- ▶ Low total cost of ownership

Archival storage requirements are quite different from those of backup operations. Media longevity and data authenticity are featured much more prominently in archive environments. The storage media used within an archive should have a stable, long life to avoid frequent data migration over decades of storage. In order to comply with corporate and government regulations on data authenticity, it is crucial that information be protected from modification.

IBM offers products for both data protection and data retention/reduction. In the SAP environment, we have, for data protection, Tivoli Storage Manager for ERP and Tivoli Storage Manager for Database. For data retention, you can use IBM



DB2 CommonStore for SAP. Both solutions can use a Tivoli Storage Manager server for the media manager. See Figure 3-5 for more details.

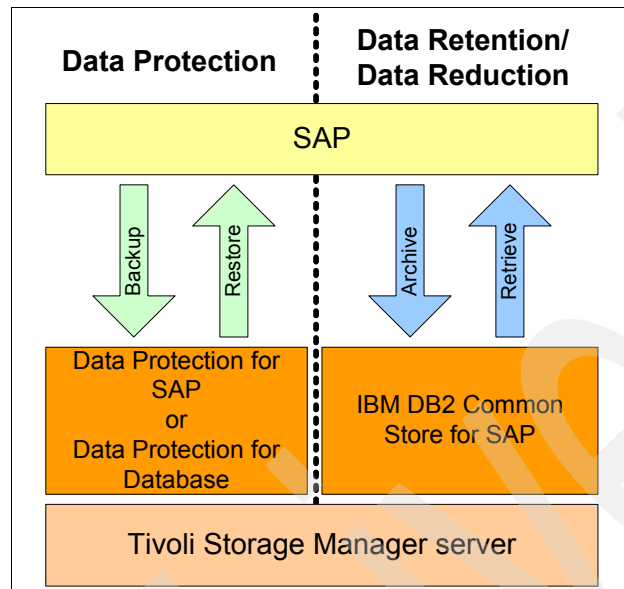

Figure 3-5 Backup and archival products

Figure 3-5 shows the two different solutions that you should be aware of. This book describes the backup and restore procedures for SAP in detail. We only have a short summary of the CommonStore product in Chapter 5, “IBM DB2 CommonStore for SAP” on page 115.

## 3.5 Tivoli Storage Manager and the SAP landscape

As discussed in 3.2, “Protection of SAP data” on page 49, there are different requirements for protecting SAP data. This section goes into more detail about which Tivoli Storage Manager product components are needed in each SAP system landscape. We discuss the following:

- ▶ 3.5.1, “Centralized SAP system” on page 70
- ▶ 3.5.2, “Distributed SAP system” on page 70
- ▶ 3.5.3, “High availability SAP system” on page 72

### 3.5.1 Centralized SAP system

The central system is the minimum system distribution. All instances of an SAP system reside on one physical machine. In addition, dialogue instances can be installed on a central system host. The central system setup is a typical installation for a development or a quality assurance system in an SAP system landscape.

Figure 3-6 shows the SAP components, the necessary Tivoli Storage Manager base components, and the Tivoli Storage Manager additions that can be installed depending on the requirements and hardware setup.

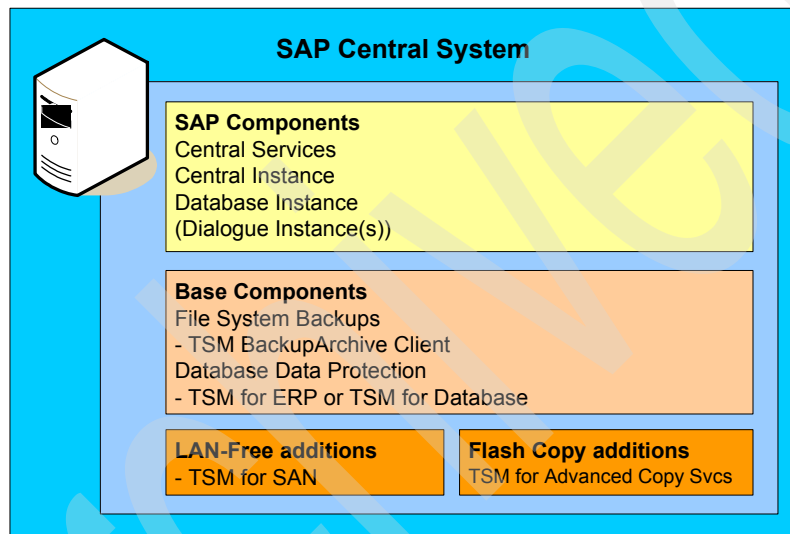

Figure 3-6 One system SAP

### 3.5.2 Distributed SAP system

The distributed system scenario hosts all or some of the SAP instances of an SAP system on two or more physical machines.

The distributed system setup can be a typical installation scenario for a test or sandbox system, which provides better performance during testing or training sessions. The distributed system divides the load between different physical machines.

Figure 3-7 on page 71 shows an example of a typical distribution of the SAP components. The necessary Tivoli Storage Manager base components, and Tivoli Storage Manager additions that can be installed, depending on the

requirements and hardware setup, are documented as well. The Tivoli Storage Manager for ERP or Tivoli Storage Manager for Database client is always installed on the server running the database instance.

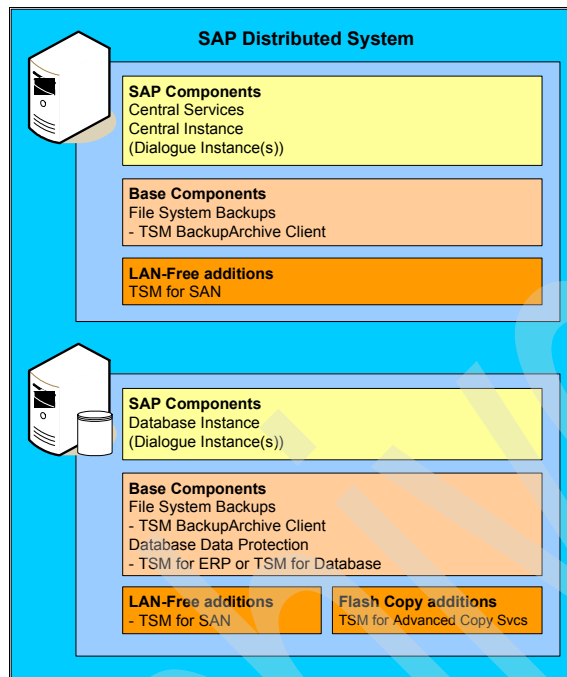

Figure 3-7 Distributed SAP installation

### 3.5.3 High availability SAP system

As shown in Figure 3-8, the high availability system scenario hosts all or some of the SAP instances of an SAP system on two or more physical machines.

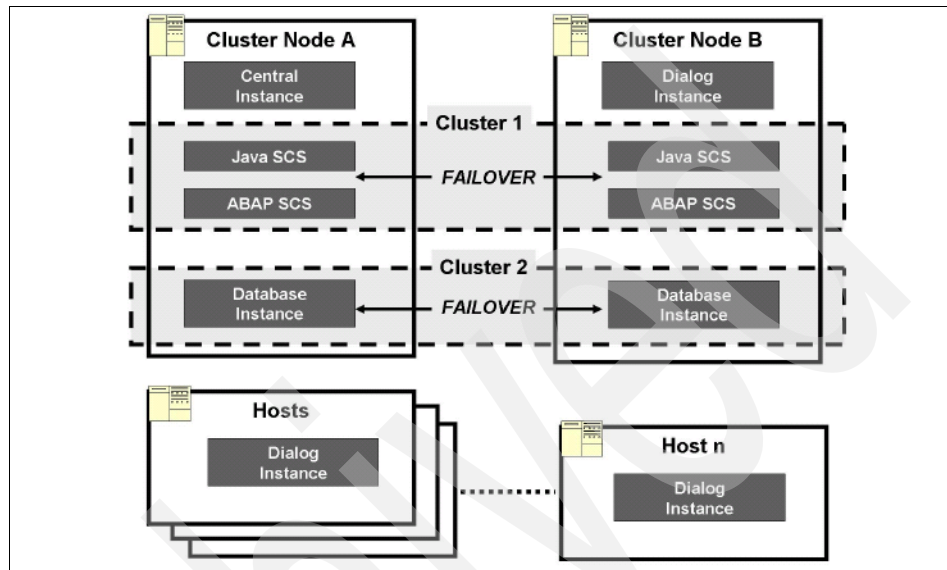

Figure 3-8 High availability

Two of the physical machines form a high availability cluster that enables failover capabilities for the SAP system and its important services, that is, the database and file system. Figure 3-9 on page 73 shows the components of an SAP system that need to be clustered.

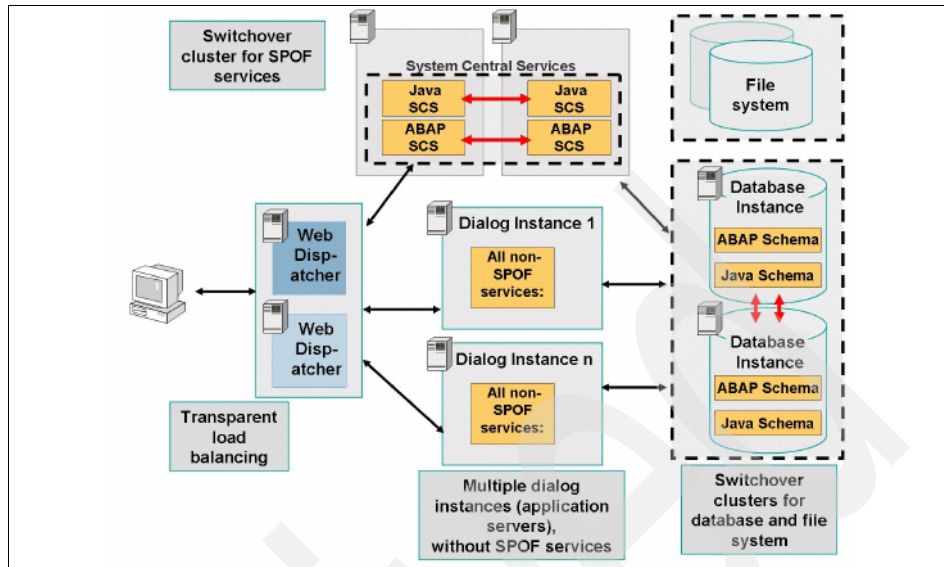

Figure 3-9 SAP system in a cluster environment

The high availability system setup is a typical installation scenario for a production system in an SAP system landscape. The high availability system divides the load to different physical machines and protects the SAP system against unplanned downtime. A very common setup for a highly available SAP production system is two servers building a switchover cluster. One server is running the central instance and central services, while the other server is running the database. Each of the nodes is designed and sized for taking the workload and tasks of the other node over.

Figure 3-10 shows an example of a typical high availability setup with two systems and where the SAP components reside. The necessary Tivoli Storage Manager base components and Tivoli Storage Manager additions that can be installed, depending on the requirements and hardware setup, are documented as well.

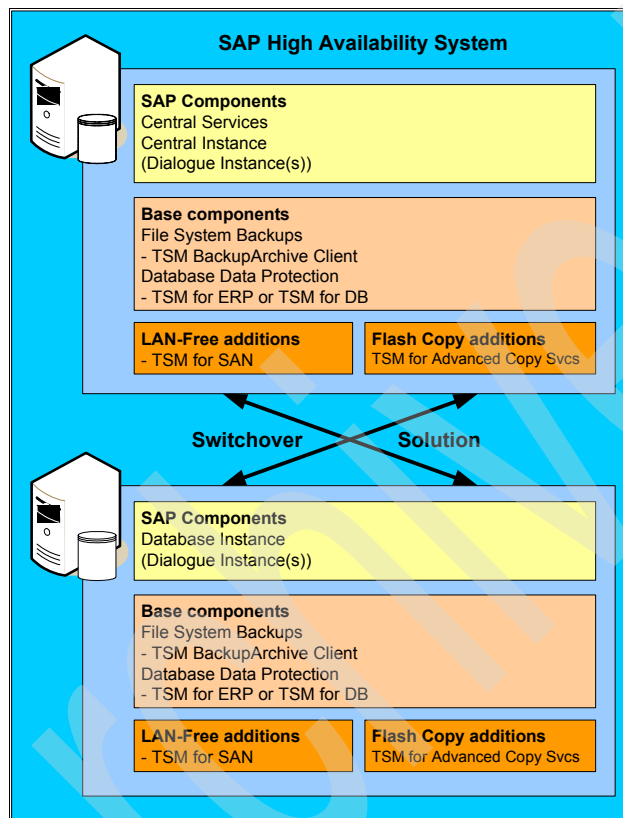

Figure 3-10 High availability SAP system

The Tivoli Storage Manager backup archive client is needed on all physical machines to back up the file systems holding executables, control files, and so on, for the SAP and database installation.

The Tivoli Storage Manager for ERP or Tivoli Storage Manager for Database client is needed on the server running the database instance, and on the second server to which the database fails over. The Tivoli Storage Manager for ERP or Tivoli Storage Manager for Database client is installed locally, which means two installations are executed. If the client is unavailable on the failover server, the database backups and redo log backups will fail.

The Tivoli Storage Manager for SAN and Tivoli Storage Manager for ACS™ products are installed as well on both systems in case they are in use.

To enable the different products to participate in the high availability failover processing, they must be defined as an application to the high availability software.

The default Tivoli Storage Manager scheduler is active in each node for local backups. Additionally, another Tivoli Storage Manager scheduler is active in the cluster node with the cluster resource group actively assigned. The Tivoli Storage Manager schedulers handling the resource group backups need to be integrated into the cluster failover tasks. In normal conditions, each node would have two scheduler processes: one for the cluster resources and one for the local file systems. After a failure, additional scheduler processes are started on a node in order to protect the resources that have moved over from another node. The backup-archive client password files must be stored on cluster disks so that after a failure, the generated backup-archive client password is available to the takeover node. The file systems to be protected as part of a resource group are defined using the backup-archive client domain option. The domain option is specified in the `dsm.sys` file, which should also be stored on a cluster disk so that it can be accessed by the takeover node.

The Tivoli Storage Manager for ERP or Tivoli Storage Manager for Database has only one ProLE process running on each host, even after takeover. Both hosts should have the same level of Tivoli Storage Manager API installed. On both hosts, the `dsm.sys` file (in `/usr/Tivoli/Tivoli Storage Manager/client/api/bin/dsm.sys`) must contain all server names required for takeover. Backint connects to ProLE using the IP address for localhost (should be 127.0.0.1 for IPv4).

For Tivoli Storage Manager for SAN, the simplest way to deploy Storage Agents in a cluster environment is to install a single Storage Agent on each physical host in the cluster. If a Backup-Archive Client instance fails from one physical host (hostA) to another physical host (hostB), it is serviced by the Storage Agent on hostB. When deploying this type of configuration, the Storage Agents should have unique names on each host, for example, `staA` on hostA and `staB` on hostB. The Storage Agents should have the same network address and communication protocol, for example, each Storage Agent can be configured to use the TCP/IP loopback address (127.0.0.1) and TCP/IP port 1500. Other considerations must be taken into account to correctly manage how tape mounts are used during a failover of an instance of the Backup-Archive Client in a clustered environment.

For Tivoli Storage Manager for ACS, three systems are required when planning for a high availability environment where a primary and takeover system will become established with a high availability solution. The takeover system for the database cannot be the FlashCopy backup system.

## 3.6 High availability

As more and more customers deploy SAP systems in SAP Business Suites for their global operations to support mission-critical business functions, such as sales and order-entry and continuous manufacturing, the need for maximized system availability becomes more and more crucial. Many companies now require 24 x 7 reliability for their SAP systems.

You can find up-to-date information about high availability on SAP Service Marketplace at the following address:

<http://service.sap.com/ha>

In SAP Business Suite, high availability requirements have become more complex, as a typical setup now includes several SAP systems, all of which are required round the clock. High availability is a technically complex area, and implementation considerations vary according to the nature of your system setup. We illustrate some of the available possibilities. You must develop high availability according to the individual requirements of your business. Refer to the appropriate source, such as your SAP consultant, your hardware supplier, or the SAP Competence Center.

### 3.6.1 Availability and performance

The term *operational* refers to both performance and availability. The key aspects of an operational system are:

- ▶ Availability

A service is said to be available if it is capable of performing the task it is designed to perform at the appropriate time.

- ▶ Performance

This is measured by the ability to meet certain predefined criteria, such as throughput of the system (for example, in number of users supported) and average response time for each user. Performance is said to be acceptable when a certain level has been achieved over a given period.

Performance clearly depends on availability. However, availability does not always guarantee performance. For example, an SAP system where the CPU utilization of the database host is very high has low performance, but it could be considered an available system. In practice, the distinction between the two aspects often blurs in extreme cases. Extremely poor performance means the system is considered to be unavailable. For example, a network connection might be terminated (that is, be unavailable) after a timeout has occurred due to



unacceptably slow performance. Even though this book focuses on the availability aspects of the system, the close relationship to the performance aspects should not be ignored.

To increase the availability of a system, it is essential to minimize downtime. Downtime can be categorized as planned and unplanned, and at a more detailed level, it can be separated into planned and unplanned downtimes for the various services that make up SAP systems, which includes the following elements:

- ▶ Front-end services, which provide the user interface, such as the Web browser or SAPGUI
- ▶ Middleware services for connection to the Web, including the Internet Transaction Server (ITS) and the HTTP Web server
- ▶ SAP services and components:
  - Individual application components of the SAP Business Suite, such as the SAP Business Warehouse (SAP BW), Enterprise Buyer Professional (EBP), and so on
  - SAP Enterprise Portal components
  - SAP system services, such as the SAP kernel, which supports application components of the SAP Business Suite
- ▶ Underlying hardware and software services, such as the database management system (DBMS) services, network and operating system services, and various hardware services, including servers, disks, and uninterruptible power supply (UPS)

Unavailability or downtime can be planned or unplanned.

- ▶ **Planned downtime:** Planned downtime is the time for scheduled maintenance and upgrades, during which a system cannot be used for normal production operations. This time is used for a variety of purposes so that a system can function optimally and reliably. Some of the possible causes of planned downtime are as follows:
  - Hardware maintenance
  - Upgrades to new releases
  - Offline database reorganization
  - Offline database backup

- ▶ **Unplanned downtime:** Unplanned downtime is the time during which a system cannot be used for normal productive operations due to unforeseen failure in hardware or software components, or operator mistakes. Unplanned downtime can be extremely costly to an organization. The source of unplanned downtime can be in any of the layers that make up the complete software and hardware environment:
  - Front-end and middleware services for connection to the Web, including the Internet Transaction Server (ITS), the SAP Web Application Server (SAP Web AS), and the SAP Enterprise Portal.
  - SAP system services of the individual application components of the SAP Business Suite, such as the Business Warehouse (BW), Business-to-Business Procurement (BBP) and the SAP kernel.
  - Underlying hardware and software services, such as the database services, network and operating system services, and various hardware services, including servers, disks, memory, and uninterruptible power supply (UPS).

### 3.6.2 High availability related consideration

To design a highly available SAP systems, you must perform the following tasks:

1. Analyze your availability requirements. Your availability requirements may include:
  - Uptime requirement (When do you need the system to be available?)
  - Downtime tolerance (How much unavailability can you absorb?)
  - Installation details, component architecture and landscape, and database size
  - Other requirements, such as budget and recovery site selection
2. Analyze potential point of failures to find single points of failure. Single points of failure must be resolved to minimize unavailability. Some potential single point of failure are:
  - SAP components and instances
  - SAP database
  - Network topology and structure
  - Disk, power, and other hardware related failure point
3. Implement measures to mitigate the risk of having a failure based on your availability requirement.

There are some common procedures for managing your system listed in Table 3-5 on page 79.

Table 3-5 SAP NetWeaver procedures for system management

System area	Description
SAP NetWeaver Application Server	SAP NetWeaver Application Server: High Availability SAP NetWeaver Application Server Java: High Availability SAP NetWeaver Application Server ABAP: High Availability
Change Management	-
System upgrade (SAP)	Upgrade (AS-ABAP)
System failure (SAP)	System Failure (SAP NetWeaver AS) Switchover Software for High Availability System Failure (AS Java)
Archiving (SAP)	Data Archiving (AS-ABAP)
Cluster administration	Cluster Technology
System monitoring and tuning	EarlyWatch Computing Center Management System (CCMS) SAP Solution Manager
Database administration (backup, upgrades, and monitoring/tuning)	Database High Availability SAPDBA: Informix Database Manager: MaxDB DB2CC Tools for DB2 UDB SQL Server Enterprise Manager
Database failure	Switchover Software for High Availability Replicated Database Servers Replicated Databases Disaster Recovery
Database - SAP connection failure	Database Reconnect (AS-ABAP)
Disaster recovery	Disaster Recovery
Network	Network High Availability
Fault reporting with follow-up	-
Switchover	Switchover Software for High Availability
System load assessment for mission-critical applications	-

Table 3-6 lists some database-specific recommendations for database point of failure mitigation.

Table 3-6 SAP NetWeaver high availability database-specific recommendations

Database	Single Points of Failure (SPOFs)
Oracle	<ul style="list-style-type: none"> <li>▶ Database Instance</li> <li>▶ Database background processes (DBWR, LGWR, SMON, PMON, and so on)</li> <li>▶ Memory structures (SGA and semaphores) You can protect the database instance using Switchover Software or Replicated Database Servers (only available for certain databases).</li> <li>▶ Database files</li> <li>▶ Control file</li> <li>▶ Current online redo log file</li> <li>▶ Data files You can protect the control file and the current online redo log file by using Oracle or proprietary disk mirroring. You can protect the data files by using disk mirroring. You should also protect all files by doing backups.</li> </ul> <p>You can use Oracle Standby Databases for a more comprehensive high availability solution that can withstand a disaster at one site.</p>
Informix	<ul style="list-style-type: none"> <li>▶ Database instance You can protect the database instance using Switchover Software.</li> <li>▶ Database data You can protect all relevant files by using Informix or proprietary disk mirroring. SAP strongly recommends some form of mirroring (preferably Informix) for, at the very least, the “critical” dbspaces (logdbs, physdbs, and rootdbs). In any case, you should also perform regular archives and backups.</li> </ul> <p>See also the Informix High-Availability Data Replication (HDR) Web page at the following address:  <a href="http://help.sap.com/saphelp_nw70/helpdata/EN/08/5744c54ae611d1894f0000e829fbbd/content.htm">http://help.sap.com/saphelp_nw70/helpdata/EN/08/5744c54ae611d1894f0000e829fbbd/content.htm</a></p>
MaxDB	<ul style="list-style-type: none"> <li>▶ Database instance You can protect the database instance using Switchover Software.</li> <li>▶ Database data You can protect all relevant devices by using proprietary disk mirroring (RAID 1 preferred) for all data volumes and log volumes. If you want to use log volumes without RAID mirroring, consider the possibility of mirroring using log mode. In any case, you should also perform regular backups.</li> </ul> <p>You can use the MaxDB Standby Database or MaxDB Hot Standby for a more comprehensive high availability solution that can withstand a disaster at one site.</p>

Database	Single Points of Failure (SPOFs)
IBM DB2 Universal Database for UNIX and Windows	<ul style="list-style-type: none"> <li>▶ Database instance You can protect the database instance using Switchover Software.</li> <li>▶ Database data You should always perform regular backups.</li> </ul> <p>See also the Replicated Standby Database for DB2 UDB for UNIX and Windows Web page at the following address:  <a href="http://help.sap.com/saphelp_nwmobile71/helpdata/en/08/5744d24ae611d1894f0000e829fbbd/content.htm">http://help.sap.com/saphelp_nwmobile71/helpdata/en/08/5744d24ae611d1894f0000e829fbbd/content.htm</a></p>
IBM DB2 Universal Database for z/OS	<ul style="list-style-type: none"> <li>▶ Database instance You can protect the database instance using Data Sharing for DB2 UDB for z/OS.</li> <li>▶ Database data You can protect the data by performing regular backups and using disk mirroring. You can also use a standby database to protect the data against disaster.</li> </ul> <p>See also the Replicated Standby Database for DB2 UDB for z/OS and Data Sharing for DB2 UDB for z/OS Web page at the following address:  <a href="http://help.sap.com/saphelp_nw70/helpdata/en/b3/81bd94bcde11d2951600a0c930df15/content.htm">http://help.sap.com/saphelp_nw70/helpdata/en/b3/81bd94bcde11d2951600a0c930df15/content.htm</a></p>
IBM DB2 Universal Database for iSeries	<ul style="list-style-type: none"> <li>▶ Database instance You can protect the database instance using Switchover Software.</li> <li>▶ Database data You should always perform regular backups.</li> </ul>
MS SQL Server	<p>See the following high availability solutions:</p> <ul style="list-style-type: none"> <li>▶ Microsoft Cluster Server on Windows</li> <li>▶ Microsoft SQL Server Standby Database</li> <li>▶ Comprehensive Microsoft SQL Server High Availability Solution</li> </ul>

### 3.6.3 Disaster recovery

A disaster is a situation in which critical components in the SAP environment become unavailable so that service cannot be resumed after a short period (less than a day as a general rule). A typical situation would be destruction of the hardware due to fire. The critical SAP system components are the database and the SAP application host instance that runs the enqueue and message services.

You must consider the following steps to protect your installation:

- ▶ To protect SAP application host running enqueue and message services  
This can be achieved by having a standby system available (at a remote site) that can be started up in the event of a disaster. If a standby system, which could also be another application server that has been reconfigured, is started to provide the critical SAP services, all other application servers have to be restarted.
- ▶ To protect the database  
The entire database can be replicated, but you have to use a method provided by the various database vendors. This approach is known as “Hot Site Backup” or “Standby Database.” The products discussed in Chapter 7, “High availability and disaster recovery concepts” on page 185 follow the concept of “replication transparency”. This means that the functionality to achieve replication is built into the database service instead of having to be coded by the client applications.

## 3.7 Backup scheduling considerations

Scheduling can provide automatic initiation of a backup process. We recommend that you schedule automated backup and archive operations to guarantee that the backup is performed on time, every time. The more complex the system is, the more necessary it is to perform automatic scheduling, such as a multiple SAP systems. You also want the scheduling system to provide a report for the tasks it performed.

There are three different possibilities to define a schedule:

- ▶ 3.7.1, “SAP scheduler” on page 82
- ▶ 3.7.2, “Tivoli Storage Manager scheduling” on page 85
- ▶ 3.7.3, “Operating system schedulers” on page 86
- ▶ 3.7.4, “External workload scheduling tools” on page 87

### 3.7.1 SAP scheduler

In the SAP system, you can use the DBA Cockpit Transaction (CCMS DB Administration Planning Calendar) to schedule backups of the database or transaction log. SAP recommends that you use the Planning Calendar to schedule all regular backups that are part of your overall backup strategy. The calendar offers two approaches:

- ▶ You can schedule backups manually, entering all the technical details yourself.

- ▶ You can schedule backups using predefined planning patterns that automatically set all technical details for the execution of the backup.

**Note:** A backup that has been scheduled in the Planning Calendar is displayed in the Job List of the Enterprise Manager. However, a backup that has been scheduled in the Enterprise Manager is not visible in the Planning Calendar.

DBA Cockpit Transaction provides a scheduler, as shown in Figure 3-11, for database administration and backup planning. The scheduler can be started with the transaction code **db13** in the SAPGUI command line or by selecting **Tools** → **CCMS** → **DB administration** → **DBA scheduling** in the SAPGUI menu.

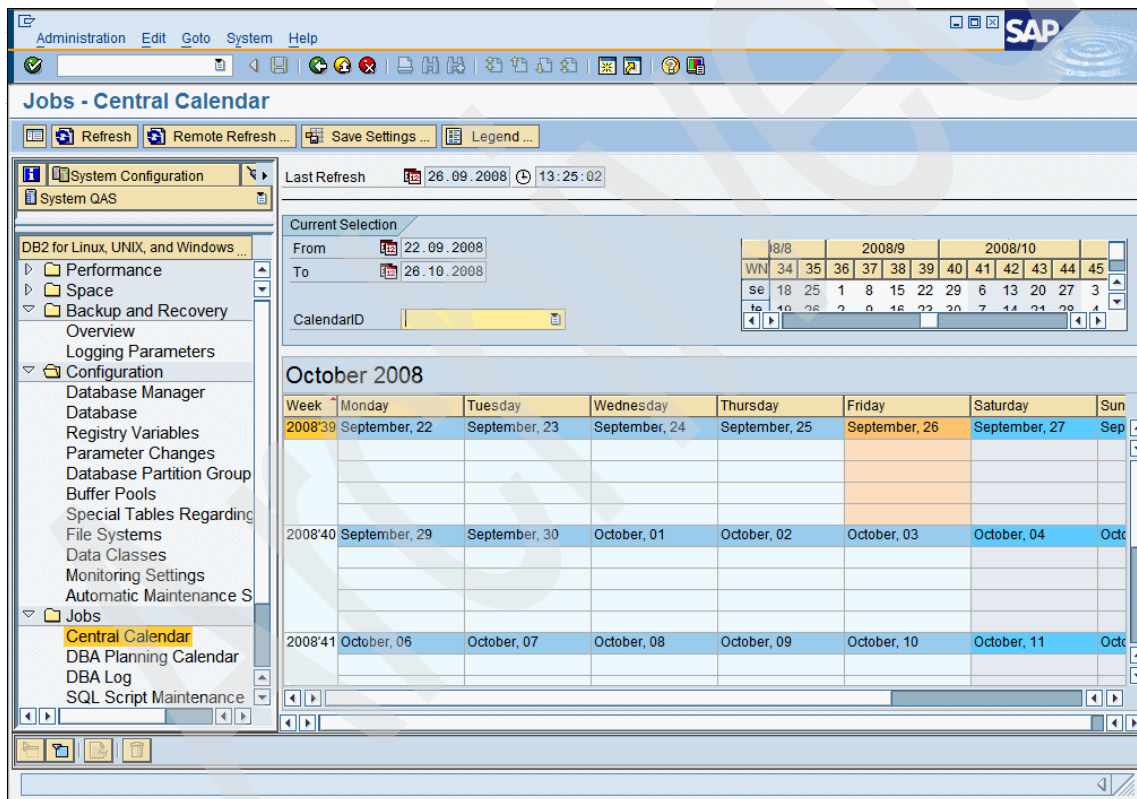

Figure 3-11 SAP DBA planning calendar

Figure 3-12 shows an example of scheduling a daily backup.

The screenshot displays the 'Schedule a New Action' dialog box. The 'Action Description' tab is selected, showing the action name 'Database Backup into TSM' and the planned start date and time '30.09.2008' at '10:06:47'. The 'Recurrence' tab is also visible, showing a recurrence pattern of 'Every 1' days at 00:00. The 'Recurrence Range' section shows the start date and time, and the option to 'End after 1 Occurrences'. The 'Execute action once' checkbox is unchecked. The bottom bar contains 'Add', 'Cancel', and 'Execute Immediately' buttons.

Figure 3-12 Scheduling daily backups

Figure 3-13 on page 85 shows scheduling a backup task using SAP cockpit.



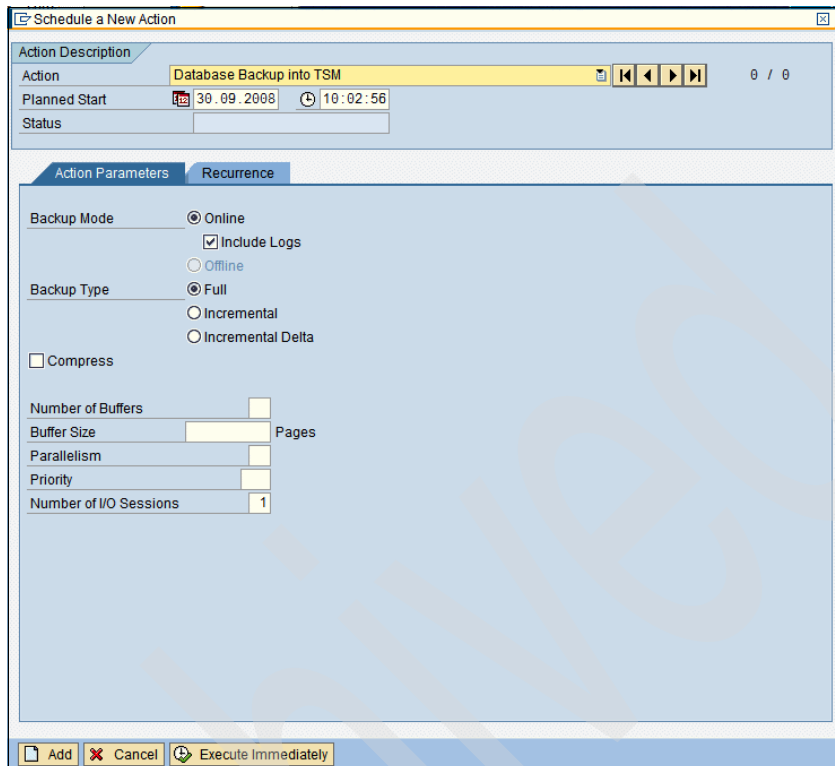

Figure 3-13 SAP cockpit: Scheduling a backup (Incremental, Full, or Delta)

### 3.7.2 Tivoli Storage Manager scheduling

To trigger an action on one or more client nodes, Tivoli Storage Manager employs the Tivoli Storage Manager scheduler. The Tivoli Storage Manager scheduler is responsible for triggering defined events on the Tivoli Storage Manager server or on the Tivoli Storage Manager nodes.

When a schedule is defined, it is assigned to a specific policy domain. You can define more than one schedule for each policy domain. The schedule invokes a command file to execute at the scheduled time. In our case, we use a shell script that starts the backup program that invokes the database backup (such as the **db2 backup**, **brbackup**, or **backom** command).

Tivoli Storage Manager provides functions for automating server and client operations. You can schedule any UNIX command line or shell script from the Tivoli Storage Manager server. In the Tivoli Storage Manager client node, you must have the scheduler client running.

The client scheduler is invoked using the **dsmc schedule** command. The scheduler can be started automatically from inittab. The schedule itself is defined in the Tivoli Storage Manager server using the DEFINE SCHEDULE command with the ACTION=COMMAND parameter to support command files. The schedule must be associated to the backup domain.

The information about triggered events for the particular Tivoli Storage Manager node as well as the result of the event is recorded in the Tivoli Storage Manager server's Activity Log on the server side and in the event log of the Tivoli Storage Manager Client Scheduler on the client side.

There are three possible results of the triggered events:

<b>Completed</b>	The task was accomplished successfully (return code = 0).
<b>Missed</b>	The task cannot be started within the defined time frame.
<b>Failed</b>	The task failed during processing (return code <> 0).

We use Tivoli Storage Manager scheduling in the case studies. See the detailed definitions in 10.4.3, "Scheduling configuration" on page 285 for Oracle databases and 9.4.4, "Schedule configuration" on page 231 and 9.7.5, "Schedule configuration" on page 255 for DB2 databases.

Besides the database backup, you also have to back up files from your database and application environment that are needed for a full recovery. In a typical production environment, this has to be scheduled in a separate schedule. You can also schedule this using the Tivoli Storage Manager scheduling.

### 3.7.3 Operating system schedulers

You can use backup automation in a UNIX system. Jobs and their scheduled times are defined in a file table. This scheduling table can be changed by the root user using the **crontab -e** command. Crontab is a native scheduling tool for the UNIX environment. It is easy to schedule backup jobs using crontab, but it has no facilities to obtain a report and job status to make management easy. You must provide all monitoring and notification facilities. For additional information about crontab format and editing, use the **man crontab** command.

For example, we use the backup script in Example 3-4 that invokes **backom**.

*Example 3-4 Backup script backup.ksh*

---

```
#!/bin/ksh
# backup.ksh
backom -c b_db -a QAS -0"
```

---

We schedule the script using crontab. The entry in crontab to start the script backup.ksh on Monday through Friday at 11:30 p.m. is shown in Figure 3-14.

```
# Sample crontab entry to be included in the root crontab jobs.  
# Save the database files (online backup) scheduled at 11:30 p.m.  
# Monday through Friday  
30 23 * * 1,2,3,4,5 /usr/bin/su - db2qas -c  
"/db264/TSM/sapscripts/backup.ksh"
```

Figure 3-14 Sample crontab entry to start a shell script to a specified schedule

### 3.7.4 External workload scheduling tools

There are other scheduling tools that allow you to perform the scheduling outside of the application environment, outside of the backup tools, and outside of the operating system. The benefit of these scheduling tools are that a backup can be scheduled and performed with the dependent tasks residing on a different application environment, with different backup tools, and on a different operating system.

Backup scheduling can be related to different events, such as:

- ▶ A batch job running a daily reconciliation job (outside of the backup tools)
- ▶ The successful daily closing of front-end tools (application independence)
- ▶ The coordination of jobs running in several machines (across the operating system)

Such scheduling tools also provide an integrated interface for monitoring and reporting of existing tasks and events. They may also provide an automated recovery facility in case something goes wrong, such as backup media full.

A sample tool is IBM Tivoli Workload Scheduler. It allows you to schedule jobs across your whole enterprise. It uses a unique planning and execution scheme that allows a very scalable backup environment. Tivoli Workload Scheduler can be integrated closely with Tivoli Storage Manager for backup processing using an extended agent. For more information about Tivoli Workload Scheduler, refer to the following books:

- ▶ *Deployment Guide Series: IBM Tivoli Workload Scheduler V8.4 and IBM Tivoli Dynamic Workload Broker V1.2*, SG24-7528
- ▶ *Implementing IBM Tivoli Workload Scheduler V 8.2 Extended Agent for IBM Tivoli Storage Manager*, SG24-6696
- ▶ *Integrating IBM Tivoli Workload Scheduler and Content Manager OnDemand to Provide Centralized Job Log Processing*, SG24-6629
- ▶ *Integrating IBM Tivoli Workload Scheduler with Tivoli Products*, SG24-6648

Archived

# Introduction to IBM Tivoli Storage Manager

In this chapter, we provide an overview of IBM Tivoli Storage Manager concepts. This includes a high-level technical introduction to IBM Tivoli Storage Manager, its architecture, and base concepts. The following topics are discussed:

- ▶ 4.1, “IBM Tivoli Storage Manager” on page 90
- ▶ 4.2, “IBM Tivoli Storage Manager storage agent” on page 97
- ▶ 4.3, “Tivoli Storage Manager for Enterprise Resource Planning” on page 97
- ▶ 4.4, “Tivoli Storage Manager for Databases” on page 105
- ▶ 4.5, “ADINT/TSM client for MaxDB” on page 106
- ▶ 4.6, “Tivoli Storage Manager for Advanced Copy Services” on page 107

## 4.1 IBM Tivoli Storage Manager

Tivoli Storage Manager presents an efficient and effective enterprise wide storage solution, including support for cross platform operation. It provides a solution for data protection, archiving, disaster recovery, space management, database and application protection, bare machine recovery, and record retention. Tivoli Storage Manager supports more than 44 operating systems platforms, using a consistent graphical user interface.

Tivoli Storage Manager provides:

- ▶ Centralized administration for data and storage management
- ▶ Fully automated data protection
- ▶ Efficient management of information growth
- ▶ High-speed automated server recovery
- ▶ Full compatibility with hundreds of storage devices, and local area network (LAN), wide area network (WAN), and storage area network (SAN) infrastructures
- ▶ Optional customized backup solutions for major groupware, enterprise resource planning (ERP) applications, and database products

### 4.1.1 IBM Tivoli Storage Manager overview

Data has become the key asset of companies and one of its most important competitive differentiating factors. Temporary inaccessibility to or the complete loss of data has a huge financial impact, and can drive companies out of business. The inability to manage data can have a negative impact on a company's profitability and can limit their ability to grow.

Tivoli Storage Manager protects an organization's data against hardware failures and other errors by storing backup and archive copies of data in offline storage. It can scale to protect hundreds of computers ranging from notebooks (mobile computers) to mainframes, running a variety of different operating systems (OSs), connected through the Internet, WANs, LANs, or SANs. Centralized Web-based management, smart data move-and-store techniques, and comprehensive policy-based automation work together to minimize data protection administration costs and the impact on both computers and networks.

Storing, protecting, and managing data growth are now among the major challenges of today's businesses, requiring solutions that go beyond traditional backup and recovery solutions.

The base functions provided by Tivoli Storage Manager and its complementary products are as follows:

- ▶ Data protection (periodic backup and restore as well as disaster recovery):
  - In operational backup and restore of data, the backup process creates a copy of the data to protect against the operational loss or destruction of file or application data. The customer defines how often to back up (frequency) and how many copies (versions) to hold.  
  
The restore process places the backup copy of the data back into a customer-designated system or workstation.
  - Disaster recovery refers to all the activities required to organize, manage, and automate the recovery process from a major loss of IT infrastructure and data across the enterprise. It includes processes to move data offsite into a secure vault location, to rebuild IT infrastructure, and to reload data successfully in an acceptable time frame.
- ▶ Data resource management (vital record retention, archive, and retrieval):
  - The archive process creates a copy of a file or a set of files representing an endpoint of a process for long-term storage. Files can remain on the local storage media or can be deleted. The customer controls how long (through the retention period) an archive copy is to be retained.
  - The retrieval process locates the copies within the archival storage and places them back into a customer-designated system or workstation.

The solution is network based, which means that these functions are available to the whole networked environment. Administration costs are minimized by centralized management of Tivoli Storage Manager components.

## 4.1.2 IBM Tivoli Storage Manager architecture

IBM Tivoli Storage Manager has a client server architecture, as shown in Figure 4-1. IBM Tivoli Storage Manager clients are the workstations, file servers, mobile computers, and other machines that must have their data protected. IBM Tivoli Storage Manager client software is installed on these systems.

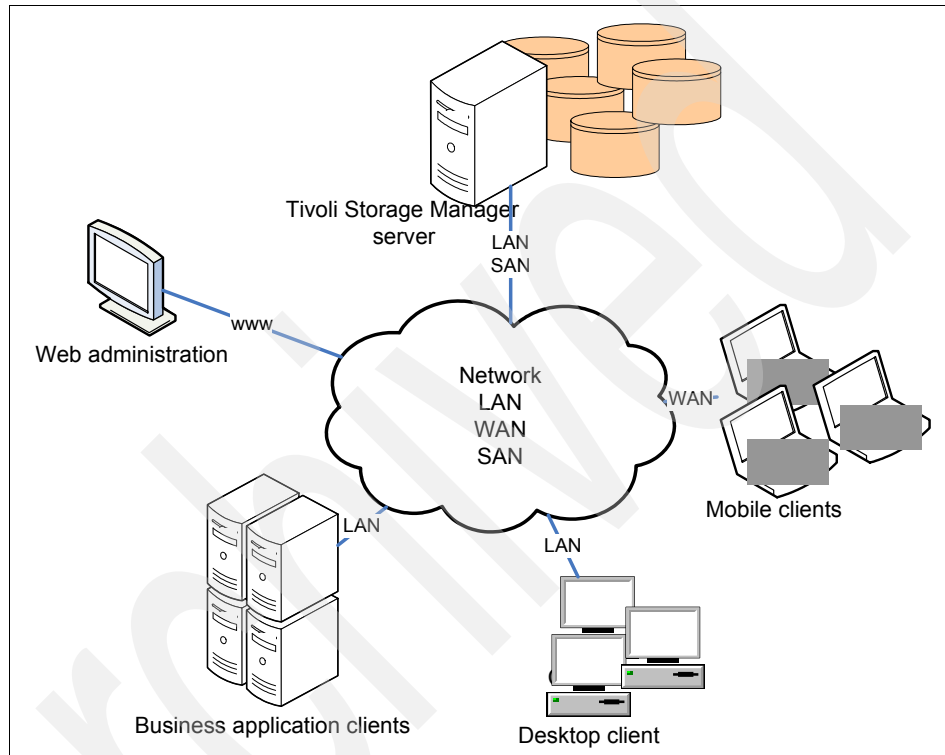

Figure 4-1 IBM Tivoli Storage Manager architecture

Tivoli Storage Manager is using a relational database and transaction log. The database and transaction log track meta data such as:

- ▶ What is backed up
- ▶ Where it is stored
- ▶ What are the policies
- ▶ Schedules
- ▶ Administrators

The transaction log enables a two-phase commit, which protects the integrity of the database and allows for interrupted backups and restores to be restarted.



The relational database empowers Tivoli Storage Manager to perform tasks such as:

- ▶ Move data from one type of storage pool to another
- ▶ Retroactively update backed-up data when a policy changes
- ▶ Track individual files
- ▶ Schedule any type of client or administrative process
- ▶ Reclaim expired dead space on tapes

The Tivoli Storage Manager client sends its data to the Tivoli Storage Manager server either over LAN or over SAN. Most backups occur based on schedules, but clients can perform on demand backups whenever they want. Clients can also perform their own restores.

The actual data that the client sends is stored in the storage pools. Tivoli Storage Manager is unique in the fact that the storage pools can form a storage hierarchy made up of more than 500 supported devices. This allows for flexibility, longevity, and, most important, fast backups and fast restores.

Most businesses back up their data initially to disk storage. This allows for hundreds of clients to back up at the same time. Then, based on policies, the data migrates in a fashion that expedites restores to tape or CD. When the data migrates, all data belonging to one client is moved together to the next pool. By keeping all of that data together, restores are faster because not as much tape positioning is required. This migration process can also accommodate movement to collocated tapes, which further expedites restores by just having one user's data on them.

The environment can be firewall protected, but you still can use the GUI interface of a Tivoli Storage Manager client. Tivoli Storage Manager allows individual configuration of nearly every TCP port that it uses for communication, as shown in Figure 4-2.

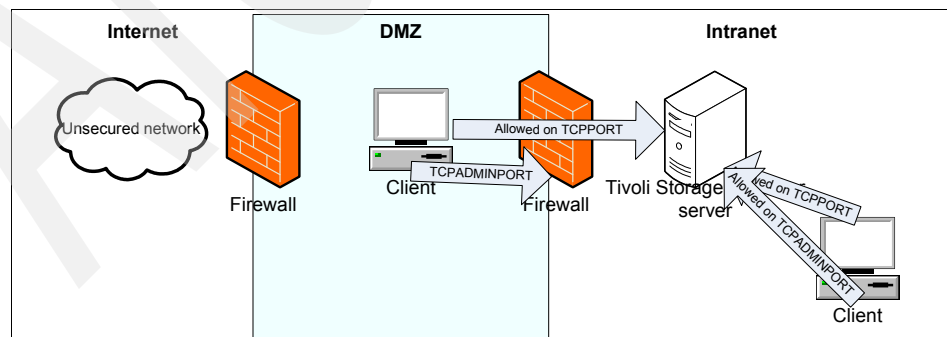

Figure 4-2 Tivoli Storage Manager client running under a firewall environment

For more information about client protection and ports, refer to *IBM Tivoli Storage Manager: Building a Secure Environment*, SG24-7505.

- ▶ TCP/IP port

To enable the backup/archive client, command-line Administrative Client, and the scheduler to run outside a firewall, the port specified by the `tcpport` server option must be opened by the firewall administrator. This port is set on the client and the server using the `tcpport` option. The setting must be the same on the client and server. The default TCP/IP port is 1500.

- ▶ TCP/IP ports for the remote workstation

The two TCP/IP ports for the remote workstation client must be opened. Use the `WEBPORTS` option in the remote workstations option file to specify these ports. If you do not specify the values for the `Web ports` option, the default zero (0) causes TCP/IP to randomly assign two free port numbers.

### 4.1.3 IBM Tivoli Storage Manager server

One of the principal architectural components of the IBM Tivoli Storage Manager server is its built-in relational database. The IBM Tivoli Storage Manager database was especially designed for the task of managing backup meta data. All policy information, logging, authentication and security, media management, and object inventory are managed within this database.

Most of the information from the database can be retrieved using:

- ▶ Tivoli Storage Manager interface SQL SELECT statements
- ▶ An Open Database Connectivity (ODBC) interface, for reporting purposes.

This database should be fully protected with software mirroring, roll-forward capability, and its own management and online backup and restore functions.

For storing the managed data, the IBM Tivoli Storage Manager server manages a storage repository. The storage repository can be implemented in a hierarchy using any combination of supported media or magnetic or optical disk, tape, and robotic storage devices, which are locally connected to the server system or are accessible through a SAN. To take advantage of SAN technology, the IBM Tivoli Storage Manager server has features implemented that dynamically share SAN-connected automated tape library systems among multiple IBM Tivoli Storage Manager servers. It also provides LAN-based backup, or LAN-free backup or Server-free backup.

The supported environment for Tivoli Storage Manager V5.5 server on AIX platform are:

- ▶ AIX 5L V5.3 (64 bit only)
- ▶ AIX V6.1 (64 bit only)

Tivoli Storage Manager V5.5 servers uses the following protocols:

- ▶ TCP/IP, which comes standard with AIX
- ▶ Shared Memory Protocol

In this book, we are focusing on AIX servers; for other supported versions, refer to:

[http://www-1.ibm.com/support/docview.wss?rs=663&context=SSGSG7&uid=swg21243309&loc=en\\_US&cs=utf-8&lang=en](http://www-1.ibm.com/support/docview.wss?rs=663&context=SSGSG7&uid=swg21243309&loc=en_US&cs=utf-8&lang=en)

#### 4.1.4 IBM Tivoli Storage Manager backup/archive client

Data is sent to or retrieved from the IBM Tivoli Storage Manager server using the IBM Tivoli Storage Manager backup/archive client and complementary Tivoli and non-IBM/Tivoli products. These products work together with the IBM Tivoli Storage Manager server base product to ensure that the data you need to store is managed as defined.

The IBM Tivoli Storage Manager backup/archive client, through the Tivoli Storage Manager server, provides the operational backup, restore, archive, and retrieve functions. The client implements the patented, progressive backup methodology, adaptive sub-file backup technology, and unique record retention methods for backup and archive functions.

The Tivoli Storage Manager client must be installed on every machine that transfers data to Tivoli Storage Manager Server. The Tivoli Storage Manager server uses a unique node name to identify each Tivoli Storage Manager client instance. A password is used to authenticate the connection between the Tivoli Storage Manager client and Tivoli Storage Manager server. Data can be recovered to the same client machine that initially transferred it, or to another client with a compatible file system format. Data backed up from a Wintel server cannot be restored over an AIX or Linux server or vice-versa.

The client customization option basically consists of the software component and a customization file. The customization file from Tivoli Storage Manager Client is called a *client options file* (*dsm.sys* or *dsm.opt*). It specifies client/server communications parameters and other Tivoli Storage Manager client settings. Client communications parameters must agree with those specified in the server options file. The client options file is located in the client directory and can be modified using a text editor. The client graphical interface also provides a wizard

for a basic editing of this file. Within the client options file, an include-exclude list can be specified. This list can be used to identify how specific files or directories are handled during backup operations. Tivoli Storage Manager Client backs up any file not specifically excluded.

These operations can be performed manually from the client machine or remotely using a Web-based interface. Backup and archive operations can also be scheduled to run automatically. An administrative client can be optionally installed with the backup archive client. The administrative client package consists of the Tivoli Storage Manager server command line, which can be used to remotely manage a Tivoli Storage Manager server from a network-attached machine.

The backup/archive clients are implemented as multi-session clients, which means that they are able to take advantage of the multi-threading capabilities of modern operating systems.

For UNIX supported environments, refer to:

[http://www-01.ibm.com/support/docview.wss?rs=663&context=SSGSG7&uid=swg21052226&loc=en\\_US&cs=utf-8&lang=en](http://www-01.ibm.com/support/docview.wss?rs=663&context=SSGSG7&uid=swg21052226&loc=en_US&cs=utf-8&lang=en)

For Windows Intel® supported environments, refer to:

[http://www-01.ibm.com/support/docview.wss?rs=663&context=SSGSG7&uid=swg21197133&loc=en\\_US&cs=utf-8&lang=en](http://www-01.ibm.com/support/docview.wss?rs=663&context=SSGSG7&uid=swg21197133&loc=en_US&cs=utf-8&lang=en)

In this book, we are focusing on UNIX and Windows Intel platforms. For further information about other supported environments, refer to:

<http://www-01.ibm.com/support/search.wss?rs=663&tc=SSGSG7&atrn=Keywords&atr=ClientRequirements>

## 4.1.5 Tivoli Storage Manager backup

The basic Tivoli Storage Manager backup is available through the **dsmc** command. This backup is performed on the file level. It is not aware of the nature or the type of the file that it backed up. For a relational database system, backup on the file level may compromise the relational integrity of the database, especially when different parts of the database are backed up at slightly different times while the database is online.

This backup method is available to all RDBMS in order to take offline backups. For online backup, this is only possible in Oracle instances using the **begin backup** and **end backup** commands. This is known as *hot backup*.

This method is not integrated in SAP BR\*Tools, which means that transactions **br12** or **CCMS** cannot show the backup reports. You have to manage the backup process and reports manually from Tivoli Storage Manager interfaces.

Tivoli Storage Manager basic backup can be used to back up non-database related objects such as SAP libraries and executables.

## 4.2 IBM Tivoli Storage Manager storage agent

The IBM Tivoli Storage Manager storage agent supports LAN-free backup solutions using a SAN infrastructure. The storage agent dynamically shares SAN connected tape libraries and disks with IBM Tivoli Storage Manager server, and it has the ability to write and read a large amount of client data directly to and from server-owned storage media.

A Storage Area Network (SAN) is a high-speed network that connects different kinds of data storage devices, such as disks subsystems, tape libraries, and juke boxes with associated data servers. The primary purpose of the SAN is to transfer data between systems and storage elements. For more information about SAN, refer to *Introduction to Storage Area Networks*, SG24-5470.

The SAN feature with the storage agent provides a great opportunity for lowering the backup window, reducing the traffic on the LAN, and reducing the utilization of the IBM Tivoli Storage Manager server. You can install the storage agent on a client machine that shares storage resources with the Tivoli Storage Manager server or on a client machine that does not share storage resources but is connected to a client machine that does share storage resources with the Tivoli Storage Manager server.

For more information, refer to *IBM Tivoli Storage Manager for SAN for AIX: Storage Agent User's Guide*, SC32-0129.

## 4.3 Tivoli Storage Manager for Enterprise Resource Planning

IBM Tivoli Storage Manager for Enterprise Resource Planning (ERP) is a component of Tivoli Storage Manager family that provides a complete backup solution for SAP databases.

The current version supports Oracle and DB2 only. For the other RDBMS, you can use Tivoli Storage Manager for Databases, which supports Oracle, Informix, and Microsoft SQL Server, as discussed in 4.4, “Tivoli Storage Manager for Databases” on page 105.

The following features are available:

- ▶ It handles large amounts of data.
- ▶ It has optimized CPU usage that reduces the overall time for backup and restore.
- ▶ It is optimized for an SAP environment.
- ▶ It supports multiple management classes.

For additional information about Tivoli Storage Manager for Enterprise Resource Planning, go to the Tivoli Storage Manager documentation available at the following address:

<http://publib.boulder.ibm.com/infocenter/tivihelp/v1r1/index.jsp>

### 4.3.1 Integration of Data Protection for SAP with SAP

Data Protection for SAP is fully integrated to the SAP environment. The communication with the backup/archive server is performed using an API called ProLE. This API is shared with other Tivoli Data Protection products. ProLE runs as a background process for communicating with the Tivoli Storage Manager server.

The administration assistant is available for the SAP or Database Administrator. This optional component provides the following features:

- ▶ Configuration of Data Protection for SAP instances
- ▶ Performance monitoring of data transfer between Database and Tivoli Storage Manager Server
- ▶ Analysis and simulation
- ▶ Monitoring of backup and restore operations
- ▶ Administration all of your Data Protection for SAP instances remotely

Figure 4-3 on page 99 shows this integration concept.

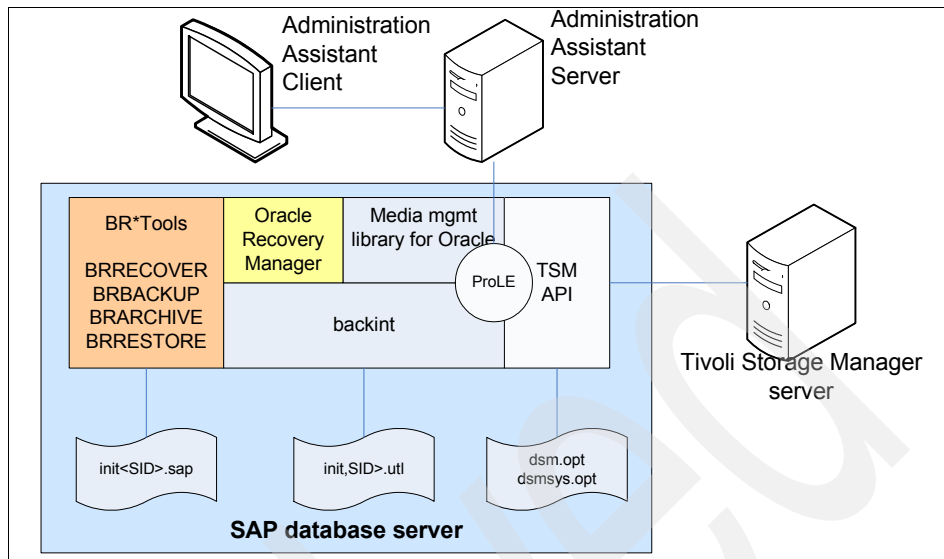

Figure 4-3 Tivoli Data Protection for SAP sample scenario

### 4.3.2 Data Protection for SAP for Oracle database

Data Protection for SAP is a client/server program that manage backups and restores in connection with Tivoli Storage Manager. With Data Protection for SAP, it is possible to handle SAP database backups, and it includes the ability to manage backup storage and processing independently from normal SAP operations. Furthermore, Data Protection for SAP in combination with Tivoli Storage Manager provides reliable, high performance, and repeatable backup and restore processes to manage large volumes of data more efficiently.

For Oracle databases, we have two options to implement a backup using Tivoli Storage Manager:

- ▶ Data Protector for SAP using the BACKINT interface
- ▶ Data Protector for SAP using Oracle Recovery Manager (RMAN)

With the integration, it is possible to follow ERP backup/restore procedures and to use the integrated SAP database utilities BRBACKUP, BRARCHIVE, BRRESTORE and SAPDBA for backup and restore. Other SAP related files (executables) are backed up by using Tivoli Storage Manager standard techniques for file backup and restore, for example, incremental backup, file filtering, and point-in-time recovery.

Figure 4-4 shows a diagram of the backup and restore process in connection with Data Protection for SAP.

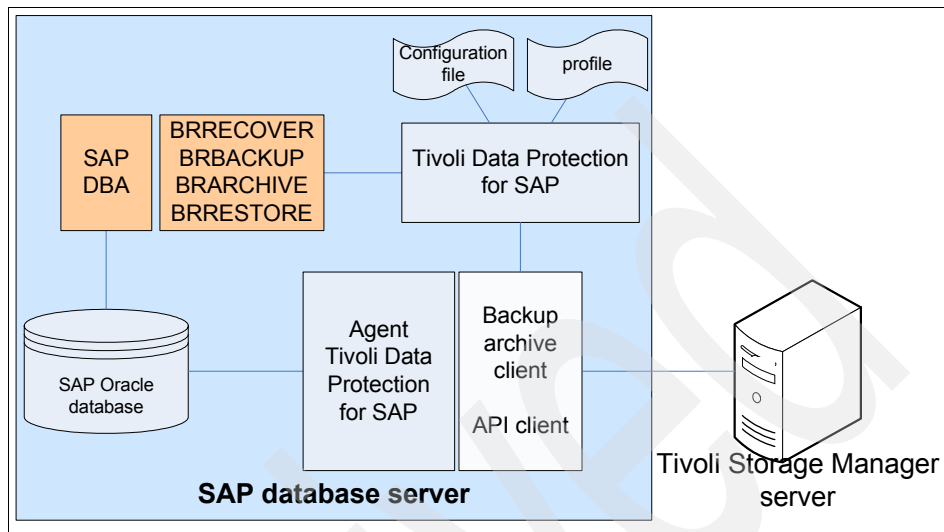

Figure 4-4 Data Protection for SAP architecture for Oracle

More discussion about the SAP backup and restore process is discussed in Chapter 6, “Database backup and recovery tools” on page 127.

The hardware and software requirements for Data Protection for SAP for Oracle database can be found at the following address:

<http://publib.boulder.ibm.com/infocenter/tivihelp/v1r1/index.jsp?toc=/com.ibm.itsmerp.doc/toc.xml>

Figure 4-5 on page 101 shows the Tivoli Data Protection for SAP for Oracle functionalities and interfaces.



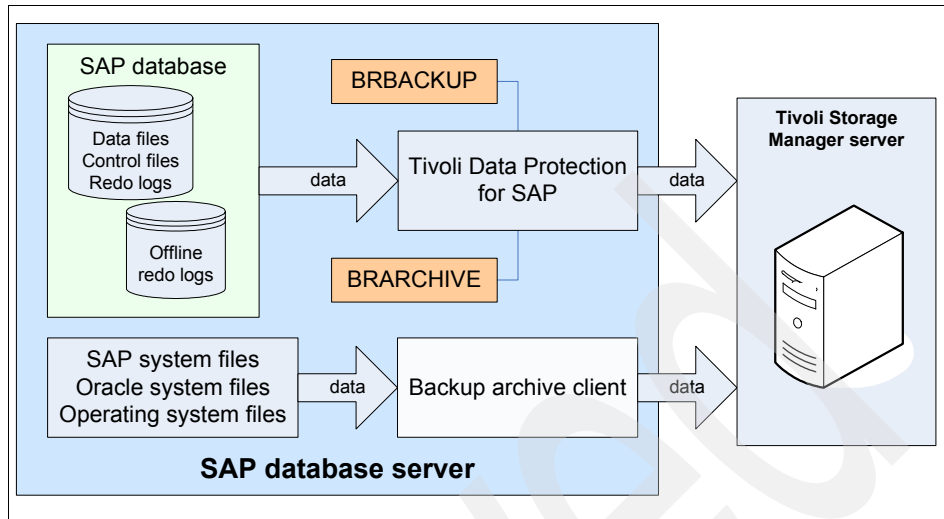

Figure 4-5 Tivoli Data Protection for SAP for Oracle overview

### Data Protection for SAP using BACKINT

Using this feature, you are able to perform the traditional Oracle online backup with automation provided by BACKINT.

Figure 4-6 shows the data interface between Oracle Databases and Tivoli Storage Manager using Data Protection for SAP for Oracle using backint interface.

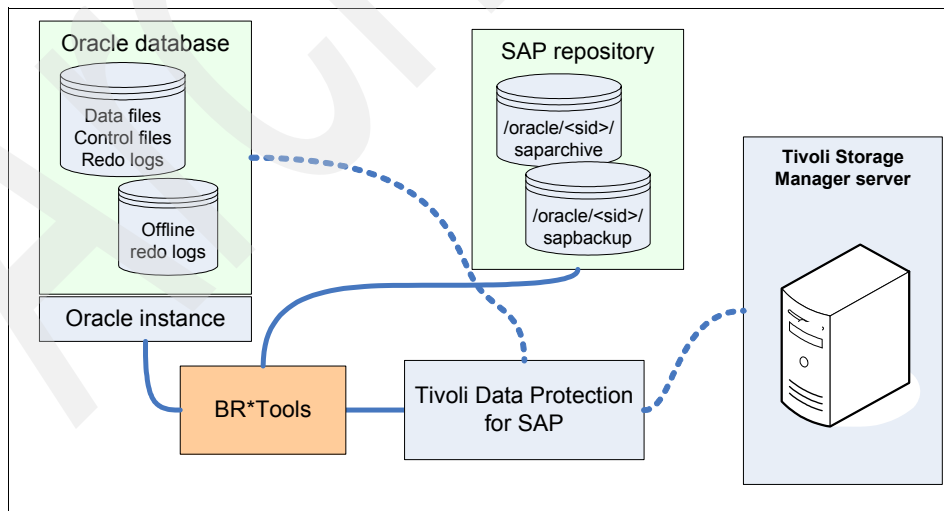

Figure 4-6 Data Protection for SAP for Oracle using Backint

The backup will proceed as follows:

1. BR\*Tools takes control.
2. BRBACKUP calls the Data Protection for SAP using Backint.
3. Backint changes the tablespace(s) to backup mode using the following command:  

```
alter tablespace <tablespace name> begin backup
```
4. Backint using Tivoli Data protector for SAP reads all the data files and saves them to Tivoli Storage Manager Server.
5. BR\*Tools updates the catalog with information regarding the backed up data file.

**Note:**

- ▶ Using this method, the chosen data files are sent to Tivoli Storage Manager one by one. No compression or block checking are performed at this level.
- ▶ When a database is in backup mode, the amount of redo logs written to disk increases. This is because Oracle writes the entire dirty block to the disk, not just the updated data.
- ▶ In some cases, when the backup routine fails for any reason, the data file remains in active backup mode. This can cause some performance impact and additional I/O to the disk.

## Data Protection for SAP using RMAN

Using this feature, you are able to take all the advantages and facilities provided by RMAN. In general, RMAN is able to perform backup in less time compared to the traditional backup using Backint. This is possible because RMAN sends only used data blocks (in an Oracle data file) to Tivoli Storage Manager. The other interesting feature is block checking, which discovers bad blocks as soon as they occur.

In addition, you can use the Oracle RMAN (Recovery Manager) utility to execute some tasks not provided by BR\*Tools, such as incremental backups, releasing backup versions, and catalog maintenance.

Figure 4-7 on page 103 shows the data interface between Oracle Database and Tivoli Storage Manager using Data Protection for Oracle for SAP using RMAN.

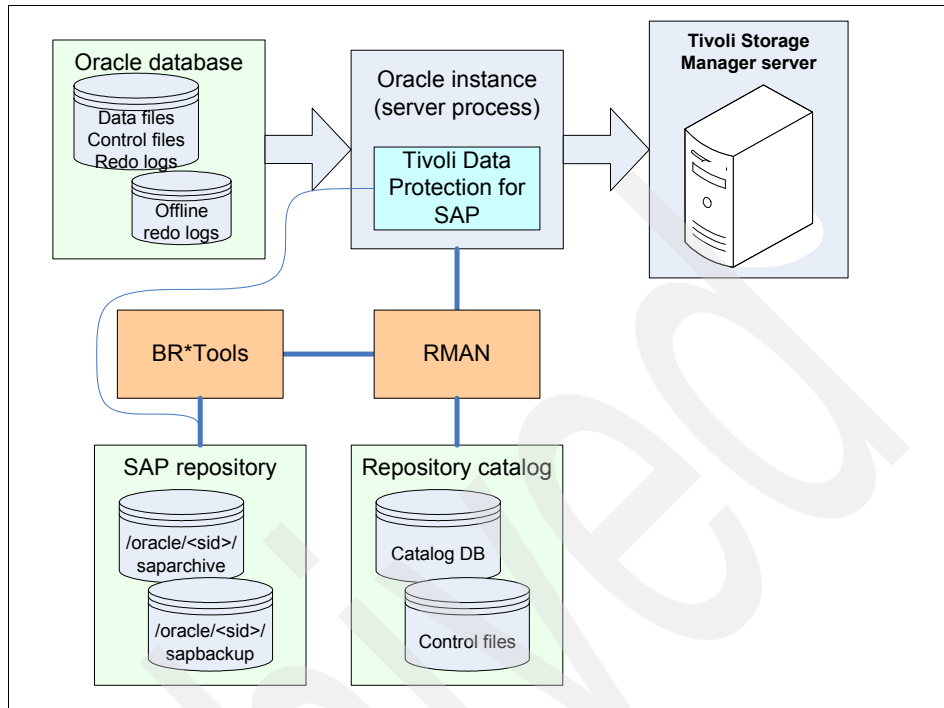

Figure 4-7 Data Protector for SAP for Oracle using RMAN

Some additional features only available to RMAN are:

- ▶ **Data Recovery Advison (Version 11g and above).** This feature helps you in analyzing and deciding what is the best recovery plan.
- ▶ **Fast Backup Compression (Version 10g and above).** This feature helps reduce the amount of data sent to the tapes.
- ▶ **Network-enabled database duplication (Version 11g and above).** Cloning databases in the network is easy. There are no requirements to have a existing backup.
- ▶ **Integration with Windows Volume Shadow Copy Services - VSS (Version 11g and above).** This feature allows the Oracle Database to participate in the VSS infrastructure on Windows platforms.
- ▶ **Backup Set encryption (Version 10g and above).** With this feature, only the backup creator is able to restore.
- ▶ **Unused Block Compression (Version 10g and above).** This feature is enabled by default. It reduces the amount of data sent to the tape by reducing the backup time.

### 4.3.3 Tivoli Data Protection for SAP for DB2

Tivoli Data Protection for SAP for DB2 was created to provide an intelligent interface to manage backup and restore using Tivoli Storage Manager. It is fully integrated in the SAP environment.

The backup command (DB2 BACKUP DATABASE) and the restore command (DB2 RESTORE DATABASE) are initiated by the DB2 command line (CLI), which calls the Tivoli Data Protection for SAP for DBA module.

The backup and restore of the DB2 log files is provided by the BR\*Tools commands BRARCHIVE and BRRESTORE. In addition, you can use the Tivoli Data Protection for SAP for DB2 Tools BackOM and the built-in Log Manager.

Figure 4-8 shows the data interface between DB2 Databases and Tivoli Storage Manager using Data Protection for SAP for DB2.

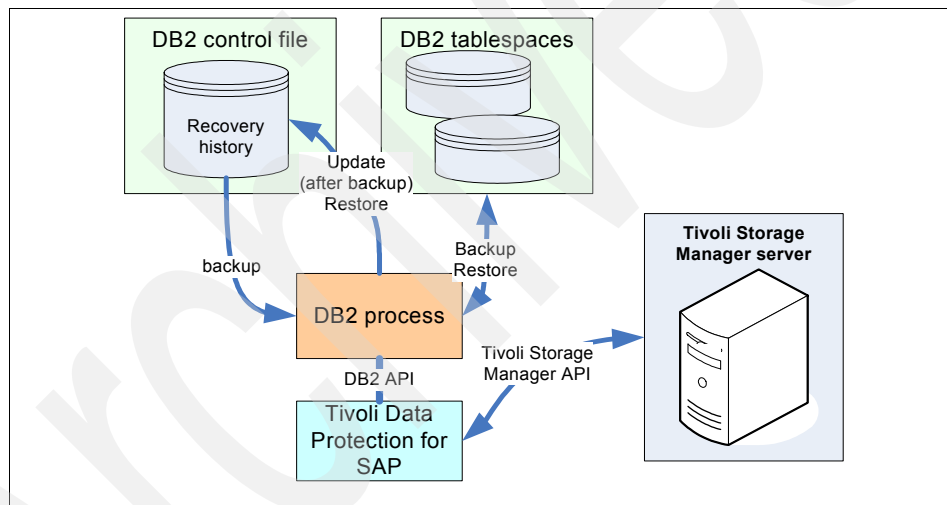

Figure 4-8 Data Protector for SAP for DB2

The archiving of DB2 offline log files is provided by the SAP tool BRARCHIVE. The retrieval of DB2 offline log files is provided by the SAP tool BRRESTORE and by the Data Protection for SAP tool BackOM. As of DB2 Version 9.X, offline log files can be archived and retrieved with the DB2 built-in Log Manager.

The DB2 Command-Line Processor (CLP) interprets commands for the DB2 database and passes control to a DB2 Server Process. In the case of Data Protection for SAP, the `LOAD <libraryname>` option causes DB2 to invoke the Data Protection for SAP shared library. This process kicks off the backup or restore, loads the library dynamically, and communicates with it through the Tivoli

Storage Manager API. For starting a backup or restore, the DB2 CLP communicates with the DB2 Server Process, providing the Server Process with the relevant information for processing the database

For more information, go to the following address:

<http://publib.boulder.ibm.com/infocenter/tivihelp/v1r1/index.jsp?toc=/com.ibm.itsmerp.doc/toc.xml>

## 4.4 Tivoli Storage Manager for Databases

Tivoli Storage Manager for Databases provide a wide range of modules to act as an interface to the Tivoli Storage Manager.

There are modules available to the following RDBMS:

- ▶ Tivoli Data Protection for Oracle
- ▶ Tivoli Data Protection for Microsoft SQL Server

Also, we have support for:

- ▶ Tivoli Data Protection for Informix (not covered in this book).

You can use these modules to back up SAP databases only when an interface is not available from Tivoli Storage Manager for Enterprise Resource Planning.

**Note:** Tivoli Storage Manager Client for DB2 is native to the DB2 product itself.

### 4.4.1 Tivoli Data Protection for Oracle

Tivoli Data Protection for Oracle has the same functionality as the Tivoli Data Protection for SAP for Oracle using RMAN, as described back in “Data Protection for SAP using RMAN” on page 102.

This applies only to Oracle using RMAN. All the stated advantages for Tivoli Data Protection for SAP for Oracle apply here as well.

### 4.4.2 Tivoli Data Protection for Microsoft SQL Server

This product provides the interface between SQL Server Databases and Tivoli Storage Manager. The functionality is most related to the SQL Server instance, as the database itself is fully integrated into the SAP environment.

Both the command-line interface and Graphic User Interface (GUI) are available to manage backups and restores.

Additional information about backing up SQL Server using Tivoli Storage Manager can be found in *Backing up Microsoft SQL Server with IBM Tivoli Storage Manager*, SG24-6148.

## 4.5 ADINT/TSM client for MaxDB

ADINT/TSM is a client program created to manage Backup and Restore of a MaxDB database using Tivoli Storage Manager. It uses a named pipe to transfer data to and from MaxDB when data from or to Tivoli Storage Manager is managed by the Tivoli Storage Manager API.

Figure 4-9 shows the data flow between MaxDB (formerly SAPDB) and the Tivoli Storage Manager using the ADINT/TSM client.

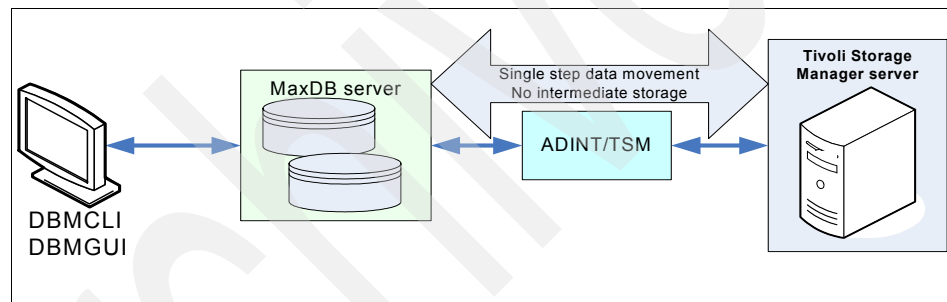

Figure 4-9 ADINT/TSM concepts

The following is the list of the main features provided by ADINT/TSM:

- ▶ Full database backup (online and offline)
- ▶ Full database backup without checkpoint (online and offline)
- ▶ Database Log backup
- ▶ Incremental backup
- ▶ Incremental backup without checkpoint

You have to use the available MaxDB tools to perform administrative tasks:

- ▶ dbmcli
- ▶ dbmgui
- ▶ webdbm

Additional information about ADINT/TSM can be found at the following address:

<http://www-05.ibm.com/de/entwicklung/esd/>

## 4.6 Tivoli Storage Manager for Advanced Copy Services

This set of tools provides a near zero-impact backup and near instance recovery solution. It uses the most recent features provided by IBM SAN Storage and is certified by SAP (BC-BCRS compliant).

This product is required to protect mission-critical data that requires 24X7 availability by providing high-efficiency backup and restore processes and eliminating backup-related performance issues by leveraging the copy services functionality of the underlying storage hardware. Using hardware-based copy mechanisms rather than traditional file-based backups can significantly reduce the backup/restore window on the production server.

Backups are performed through an additional server called the backup server, which performs the actual backup. Because the backup operation is offloaded to the backup server, the production server is free from nearly all the performance impact. The production server's processor time is dedicated for the actual application tasks, so application users' performance is not affected during backup.

Tivoli Storage Manager for Advanced Copy Services is used in conjunction with other products that interact with the applications and perform the backup from the backup server to Tivoli Storage Manager. The products with which it interfaces are:

- ▶ Tivoli Storage Manager for Enterprise Resource Planning (Data Protection for SAP)
- ▶ Tivoli Storage Manager for Databases (Data Protection for Oracle)
- ▶ Tivoli Storage Manager built-in interfaces for DB2 UDB

Also, Tivoli Storage Manager for Advanced Copy Services has these modules currently available:

- ▶ Data Protection for FlashCopy Devices for Oracle (currently at Version 5.3)
- ▶ Advanced Copy Services for DB2 UDB (currently at Version 5.3)
- ▶ Data Protection for Snapshot™ Devices for DB2 Advanced Copy Services (currently at Version 5.5)
- ▶ Data Protection for Snapshot Devices for mySAP for Oracle (Version 5.4)
- ▶ Data Protection for Snapshot Devices for mySAP for DB2 UDB (Version 5.4)

We have used the abbreviated term Data Protection for FlashCopy as a generic term for all these products, specifying either SAP Oracle, SAP DB2, DB2, or Oracle where we have to be more specific. Tivoli Storage Manager for Advanced Copy Services was previously known as Tivoli Storage Manager for Hardware, which was supported on the IBM Enterprise Storage System (ESS) only. It had the following modules:

- ▶ Data Protection for IBM ESS for SAP with DB2
- ▶ Data Protection for IBM ESS for SAP with Oracle
- ▶ Data Protection for IBM ESS for DB2
- ▶ Data Protection for IBM ESS for Oracle

Updated information about the Tivoli Storage Manager for Advanced Copy Services is available at the following address:

<http://publib.boulder.ibm.com/infocenter/tivihelp/v1r1/index.jsp?topic=/com.ibm.itsmerp.doc/fbro000074.htm>

#### 4.6.1 Supported storage hardware

Tivoli Storage Manager for Advanced Copy Services is supported on the following IBM System Storage disk systems:

- ▶ DS8000

The IBM System Storage DS8000 is a high performance, high capacity series of disk storage systems. It provides around six times higher performance than the earlier ESS model and also scales from 1.1 TB to 320 TB. The IBM POWER5™ server technology in the DS8000 makes it possible to create storage system logical partitions that can be used for completely different environments. For more details, go to the following address:

<http://www.ibm.com/servers/storage/disk/ds8000/index.html>

- ▶ DS6000™

The IBM System Storage DS6000 is a mid-range storage system with all the features and functions of an enterprise storage system. It also offers excellent price, performance, and scalability. You can expand the DS6000 system by adding an expansion enclosure to the DS6800 controller, or grow horizontally by adding other DS6800 controllers. For more details, go to the following address:

<http://www.ibm.com/servers/storage/disk/ds6000/index.html>

- ▶ SAN Volume Controller (SVC)

The SVC is a virtualization layer that allows addressing of a heterogeneous configuration of IBM and non-IBM storage devices through one interface to an open systems host. Traditionally, LUNs that are defined within a storage



system are directly presented to the host. SVC provides virtualization by creating a pool of managed disks from the attached storage systems, which are then mapped to a set of virtual disks for use by attached host computer systems. SVC provides a single interface to the management and provisioning of diverse disk systems, as well as a single set of FlashCopy, Metro Mirror, and Global Mirror functions. For more details, go to the following address:

<http://www.ibm.com/servers/storage/software/virtualization/svc/index.html>

► Enterprise Storage Server®

The IBM TotalStorage Enterprise Storage Server (ESS) architecture is the basis for subsequent enterprise disk systems. It can be attached to IBM and non-IBM servers of many types, and provides high capacity and function. Because it has been replaced by next generation disk products, it is no longer marketed; however, it is still commonly found in client environments. For more details, go to the following address:

<http://www.ibm.com/servers/storage/disk/ess/index.html>

## 4.6.2 Introduction to copy services

Copy services are a collection of functions that provide disaster recovery, data migration, and data duplication. Copy services provide a point-in-time copy (known as FlashCopy in IBM disk systems) as well as remote mirror and copy functions. Generally, a point-in-time copy is used for data duplication and backups, while remote mirror and copy functions are used for data migration and disaster recovery. With copy services, you can create backup data with little or no disruption to your application and also back up the application data to a remote site for disaster recovery purposes.

FlashCopy enables you to create full volume copies of data. When you set up a FlashCopy operation, a relationship is established between the source and target volumes and a bitmap of the source volume is created. Once this relationship and bitmap are created, the target volumes can be accessed as though all the data had been physically copied. While a relationship between the source and target exists, a background process optionally copies the racks from the source to the target volume. When a FlashCopy operation is started, it takes only a few seconds to complete the process of establishing the relationship and creating the necessary bitmaps. Thereafter, you have access to the point-in-time copy of the source volume. If you access the source or the target volumes during the background copy, FlashCopy manages these I/O requests and facilitates both reading from and writing to both the source and target volumes. Once all the data has been copied to the target, the FlashCopy relationship is ended, based on the

type selected. The FlashCopy types, full volume copy (COPY), no copy (NOCOPY), and incremental (INCR), are available.

A FlashCopy operation always works on a full disk volume, (there is no partial volume FlashCopy). Similarly, on a FlashBack restore, all data on the volume is overwritten. Therefore, the content of the volume on which you perform FlashCopy should be a unit of information, as it contains only SAP data files. Defining a separate volume group or groups for the SAP data devspace should prevent this occurrence. For performance reasons, you might want to define more than one volume group, so that those tablespaces with higher activity can be separated onto different volume groups or storage arrays in the disk storage system. A relationship is then established between the source and the target volumes, and a bitmap of the source volume is created. When this step is finished, the data can be accessed on the target volume as though the data had already been copied; for example, we could start a backup of the target volume to a Tivoli Storage Manager server at this point. The copy process continues in the background.

Figure 4-10 shows the process we have just described.

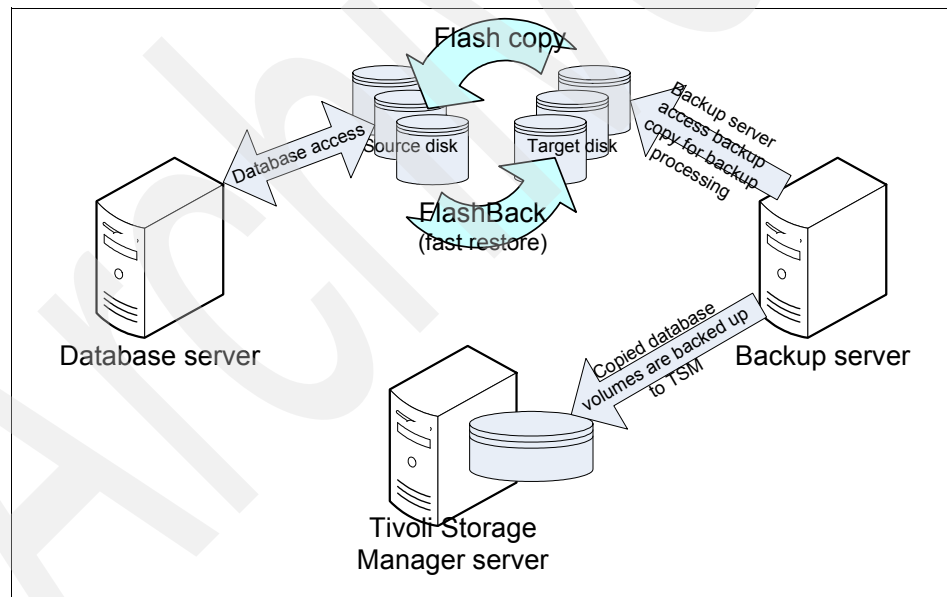

Figure 4-10 FlashCopy concepts

In the bitmap-table, used for the relationship between source and target volumes, each track copied by the FlashCopy service will be marked as processed. Reads can be done on both volumes, on the source as well as on the target side. Whenever a track is not yet copied to the target, the track will be read from the

source volume. Whenever a write operation is done to the source volume, that track has to be copied to the target volume first, because we must know the status at the time of starting the FlashCopy process. This process ensures that the production server is minimally affected by the backup operation, which can be started as soon as the relationship is established between source and target volumes. Remote Mirror is another option for volume replication; however, it does not allow concurrent access to the target volumes while the copy process is running. The FlashCopy service provides this capability by creating a bitmap for the source volume. FlashCopy is the copy service method used by Tivoli Storage Manager for Advanced Copy Services.

### 4.6.3 Tivoli Storage Manager for Advanced Copy Services on SAP

The following are the main advantages to using Tivoli Storage Manager for Advanced Copy Services Data Protection for FlashCopy for backing up an SAP system:

- ▶ The SAP databases only have to be quiesced for a short time while the relationship between the FlashCopy source and target volume is set up and the relationship-bitmap table is created. Thus, the outage time for the SAP system during backup is reduced from hours to just seconds.
- ▶ The time to restore from FlashCopy backup is just seconds. It is not necessary to transfer data from a from a tape device of a backup server; the restore is done at a hardware level. Naturally, you will then have to recover the database by applying transaction logs (rollforward); however, typically this takes much less time than a traditional tape restore.
- ▶ It is certified by SAP for Split Mirror Disk Backup.

The BR\*tools, if the SAP system uses an Oracle-database, or the DB2-interface, if the SAP system is on DB2 UDB, communicate with Data Protection for SAP to execute a database backup or restore. Data Protection for SAP communicates with Data Protection for FlashCopy, which communicates with the CIM agent for the storage system. The CIM agent then instructs the storage system to perform the FlashCopy operation. In order to minimize the load on the SAP production system, the backup process is executed on a different system, known as the backup system, connected to the same DataStorage system.

#### **Advanced Copy Services for DB2 UDB**

The ACS for DB2 interacts with the FlashCopy services in order to improve performance and to minimize the impact of performing database server backups. It does this task by off-loading the data transfer of the Database Server to the Backup Server.

## DP for Snapshot Devices for mySAP (Oracle)

DP for Snapshot Devices for mySAP provides high-availability and high performance backup of an Oracle database implemented on FlashCopy devices.

It is a co-product of Data Protection for mySAP and easily integrates with the FlashCopy volumes, allowing the high-performance remote database backup of Oracle databases while the primary database instance is running and available to the users (no downtime is required). Most of the backup operation occurs in the backup system using the FlashCopy target volumes, thus reducing the CPU and I/O utilization.

Figure 4-11 summarizes the backup process flow on Oracle.

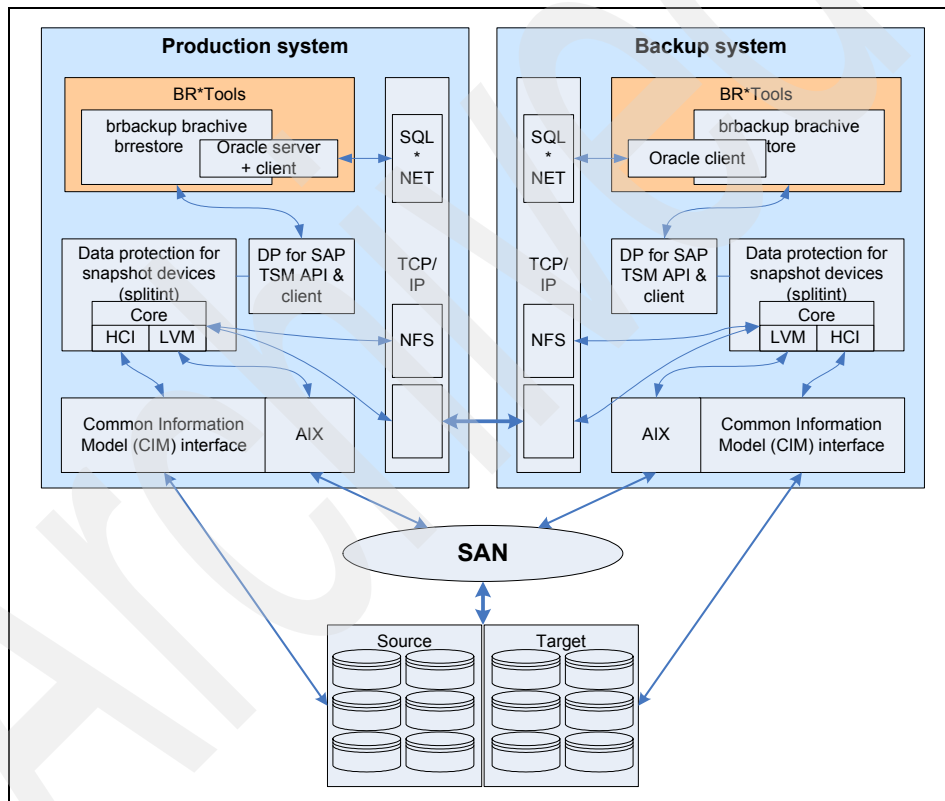

Figure 4-11 Principle of Data Protection for FlashCopy on an Oracle based SAP system

## DP for Snapshot Devices for DB2 Advanced Copy Services

DP for Snapshot Devices for DB2 Advanced Copy Services is an improvement of the DB2 Advanced Copy Services (DB2 ACS) software component provided with the DB2 High Availability Feature as of DB2 V9.5. DP for Snapshot Devices offers the following enhanced functionality compared to DB2 ACS:

- ▶ Offloaded transfer of backup data from the DB2 database server to Tivoli Storage Manager (TSM). The source for this transfer is a snapshot backup previously generated by DB2 ACS. The tape backup can be integrated with the request to generate the snapshot backup.
- ▶ Unlimited number of snapshot versions.
- ▶ Incremental and “no copy” FlashCopy variants (using the INCR and NOCOPY options).
- ▶ Snapshot backup from a mirror set managed by the AIX LVM mirroring function (except for N series devices) and corresponding snapshot restore.
- ▶ Support for the Journaled File System (JFS).

**Note:** The term DB2 Advanced Copy Services applies to the software components delivered by DB2 as part of the DB2 High Availability Feature. These components are updated when DP for Snapshot Devices is installed and are then referred to as the DB2 ACS components of DP for Snapshot Devices.

The process flow for DB2 is shown in Figure 4-12.

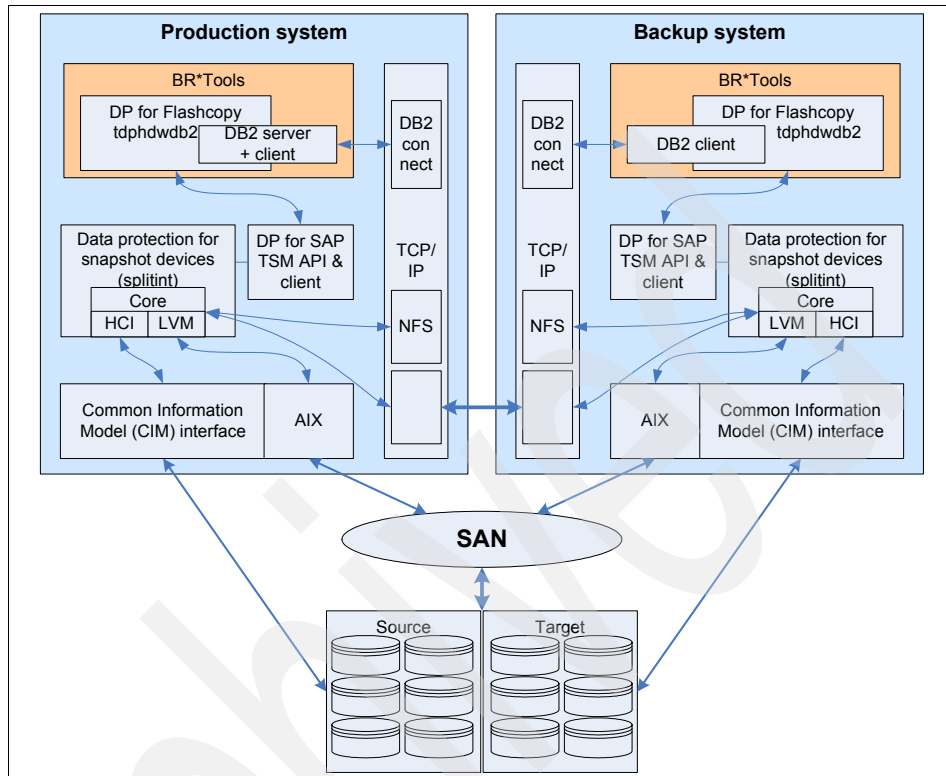

Figure 4-12 Principle of Data Protection for FlashCopy on a DB2 based SAP system

# IBM DB2 CommonStore for SAP

This chapter describes the IBM DB2 CommonStore for SAP product. As CommonStore is an archiving solution and *not* a backup solution, this book gives only an overview of CommonStore for SAP. We do not describe the setup and configuration of it. The chapter is divided into the following sections:

- ▶ 5.1, “CommonStore for SAP overview” on page 116
- ▶ 5.2, “Scenarios and features” on page 119
- ▶ 5.3, “CommonStore for SAP server prerequisites” on page 121
- ▶ 5.4, “CommonStore clients” on page 122
- ▶ 5.5, “References” on page 126

## 5.1 CommonStore for SAP overview

Starting with SAP Release 2.2, SAP clearly recognized the need to enhance SAP through a robust archiving facility for both offloading the operational SAP database and processing business documents that reside in an external archiving system. With SAP Release 3.0, all key applications and modules offered archiving functionality that was shipped as part of the standard SAP package. These new features leveraged the power of tools like the SAP Business Workflow, Document Management System, SAPoffice, SAPconnect, or Archive Development Kit.

As the application now fully supports handling of external documents, SAP decided to leave the core archiving functionality to their Business Partners. The SAP Business Framework provides the interfaces necessary to integrate these external functions with SAP.

The primary interface for integrating storage and content management systems in SAP is called SAP ArchiveLink™. It was introduced with Release 2.2 and enhanced in subsequent releases. Additionally, the SAP HTTP Content Server Interface was defined in SAP Release 4.5 as a subset of ArchiveLink that focuses on content rather than storage management.

IBM Content Manager CommonStore for SAP is based on ArchiveLink and the HTTP Content Server Interface. These interfaces support a generic archiving system or external archives, such as optical media, scanners, optical library, and so on.

HTTP Content Server Interface is a general, cross-application interface that connects the enabled SAP business applications to a content server and allows them to process documents in logical content repositories. This content server can be a database, a file server, an SAP system, or an external archive like CommonStore.

The HTTP Content Server Interface interface is completely based on Hypertext Transfer Protocol (HTTP). Servers and documents are transmitted between CommonStore and an SAP application server using a Universal Resource Locator (URL). This is typically performed by CommonStore primarily to exchange content within a corporate intranet.

CommonStore integrates with HTTP Content Server Interface to perform functions like:

- ▶ Storing, updating, or appending documents in a content repository
- ▶ Retrieving entire documents or document segments from a content repository
- ▶ Obtaining information about documents and their components



- ▶ Searching documents for text patterns (without retrieving them)
- ▶ Performing attribute-based searches (on print lists, especially journals)
- ▶ Deleting documents

To prohibit unauthorized access to archived documents, CommonStore applies security measures to prevent the forgery or manipulation of URLs and eavesdropping on contents. These measures include the use of a PKCS#7 digital signature and public key procedure according to the Digital Signature Standard. The degree of protection and rights of access to a document can be specified when a document is stored by SAP.

All ArchiveLink operations are based on the notion that the SAP database represents a master index catalog of all documents, including those whose content resides in the external archive. According to this approach, ArchiveLink passes no document-related information to the external archiving system. Instead, a symbolic Universal Unique Identifier (UUID) is created for each document and applied to it to identify it throughout its life cycle.

ArchiveLink itself maintains a table that maps each business document (for example, credit memo or customer invoice) to its corresponding UUID. For many SAP users, however, it is a requirement to access archived documents independently of SAP or mySAP.com (that is, without using the SAP GUI or the mySAP.com Workplace). In this case, to support searching the external archive for business information like customer number or fiscal year, CommonStore provides proprietary function modules that transfer these respective document attributes from SAP to the archive database.

In order to support archiving functions and scenarios that cannot be covered by the client/server perspective, HTTP Content Server Interface is based on CommonStore, which supports the additional protocols covered by ArchiveLink. In their entirety, the supported ArchiveLink 4.5 functions (which have not been changed with SAP Release 4.6 or mySAP.com) comprise:

- ▶ HTTP Content Server Interface
- ▶ Business Application Programming Interface (BAPI®) for bar code-based archiving scenarios
- ▶ OLE (Object Linking and Embedding) functionality for storing inbound documents or PC files and starting external viewing applications (for example, archive clients) on 32-bit Windows front ends

When used with SAP Releases prior to 4.5 that do not support HTTP Content Server Interface, CommonStore substitutes the operation with Remote Function Call (RFC). See CommonStore architecture in Figure 5-1 for more details about this topic.

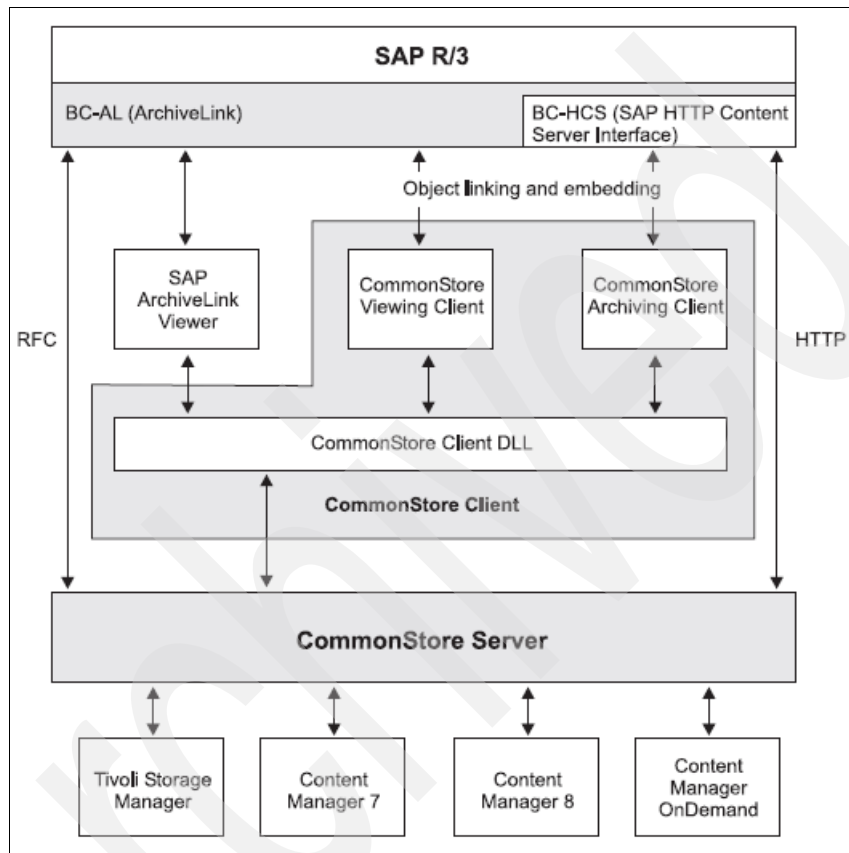

Figure 5-1 CommonStore architecture

As shown in Figure 5-1, CommonStore consists of the following components:

- ▶ The CommonStore Server is the most important component of CommonStore. It handles the whole archiving functionality.
- ▶ The CommonStore client, which in turn consists of the CommonStore Dynamic Link Library (DLL) and either the CommonStore Archiving Client or the CommonStore Viewing Client (alternatively, the SAP ArchiveLink Viewer can be used). See also the *IBM DB2 CommonStore for SAP: Client Installation and User's Guide*, SH12-6744 for more information.

## 5.2 Scenarios and features

As there are diverse applications for archiving and content management in the SAP and mySAP.com environments, integrating CommonStore into the SAP landscape can bring multiple benefits. In this section, we discuss:

- ▶ 5.2.1, “Data archiving” on page 119, which is driven by system administration
- ▶ 5.2.2, “Document archiving” on page 120, which is driven by business process optimization

### 5.2.1 Data archiving

When an SAP system goes into production, its database usually has a size that allows efficient storage of data on local hard disks of the database server. While new data is entered and generated during production, the database size increases continually. This approximately linear database growth depends on the intensity of system usage and may easily reach rates of 30 to 50 percent per year.

This rapid evolution has several inadvertent side effects:

- ▶ Because the physical tables are usually stored on hard disks directly attached to the database server, an increase in hard disk requirements is unavoidable.
- ▶ Due to an increase in administration effort for the database, maintenance windows (for example, for system backup) claim unacceptable amounts of time.
- ▶ The increased number of rows per database table delays basic operations (for example, searching tables). The accumulation of these delays leads to a perceptible degradation of response times when accessing the database.

As practical experience has shown, the database growth noticeably affects the system performance and administration effort within one to two years of usage. SAP recommends archiving to remove the bulk of data that is not actively used. CommonStore can be employed to perform this task. It is capable of archiving inactive data during regular system operation times.

Application data archived through CommonStore is stored independently from the SAP system, such as optical media or magnetic tape. The data is compressed by up to a factor of five during archival. Furthermore, the data is accessible by SAP at any time and can even be analyzed in the external archive. Archive data is not affected by hardware or release changes for the SAP system.

## 5.2.2 Document archiving

For legal and internal policy reasons, companies are sometimes required to keep records for a certain period of time. Conventionally filing these documents on paper or in microfiche archives results in:

- ▶ Extensive cost for duplicating or filming the documents to be stored
- ▶ Expenditures for the physical storage of paper or microfiche media
- ▶ Inefficient retrieval of stored documents

However, most business processes supported by SAP allow processing documents electronically, as opposed to a paper-based process. The benefits of this approach include:

- ▶ The ability to use cost-efficient storage media for the document repository
- ▶ Direct access by all authorized users without the delay caused by conventional archive inquiries
- ▶ Parallel access by several users at the same time
- ▶ The option of leveraging SAP Business Workflow to improve existing work routines
- ▶ Increased customer satisfaction through optimized processes

CommonStore is capable of handling different kinds of electronically represented documents. The following groups of document types should be differentiated:

- ▶ Inbound documents (for example, supplier invoices) that reach the enterprise through mail or telefax and are stored as rasterized images. For this document type, the advantages of using CommonStore come are apparent.
- ▶ Outbound documents, which are normally printed and sent to their respective recipient. CommonStore not only provides for fast retrieval in case of internal or external audits, but also for quick referral for inquiries by customers or suppliers.
- ▶ Reports and print lists (for example, journals), which are generated by SAP and would normally be printed. The use of CommonStore typically makes a physical printout obsolete. The electronic journal (as opposed to its paper equivalent) is easily searchable and can even contain hyperlinks to other documents (as an example, a specific entry in a document journal might refer to a scanned original document). Furthermore, the archived lists can be used as input to other applications like data mining systems.
- ▶ Desktop files created by PC applications (for example, office or CAD applications) can be stored through CommonStore and accessed by SAP users through SAP office or other Document Management System (DMS).

In addition to these basic document types handled by CommonStore, a typical requirement for an archiving system is to store documents from external applications and make them available to SAP users. This particularly includes computer output on laser disc (COLD) that was generated outside of SAP.

## 5.3 CommonStore for SAP server prerequisites

SAP and archive system installations are used in companies ranging from global trusts with very high document volumes to mid-sized companies with a few hundred invoices per day. This bandwidth is responsible for the large variations in customer demands regarding performance, availability, and the scalability of the corresponding systems. CommonStore considers this factor and supports a wide variety of hardware platforms, allowing customers to choose based on the demands of the application scenario.

CommonStore runs on AIX, Digital UNIX, HP-UX, Linux, OS/400®, Windows 2000, Windows XP, and Windows Server® 2003, as well as in the Sun Solaris™ Operating Environment. However, the main archiving load can be distributed among every system supported by Tivoli Storage Manager, Content Manager OnDemand, or Content Manager. Through the flexible hardware support offered by Tivoli Storage Manager, CommonStore also allows the storage of SAP documents on quite arbitrary storage media, including hard disks, tape drives, optical media, or corresponding library systems.

Before you start the preparations for installing CommonStore for SAP, make sure that the following software is installed on the computers specified:

On the archive server, CommonStore supports the following archive server software:

- ▶ CommonStore server on AIX and Windows only
  - Content Manager for Multiplatforms V7.1 (for AIX and Windows)
  - Content Manager for z/OS and OS/390 V2.3
- ▶ CommonStore Server on AIX, Linux, Windows, or Sun Solaris
  - Content Manager for Multiplatforms V8.2 or later (for AIX, Sun Solaris, Linux, and Windows)
  - Content Manager for z/OS V8.2
- ▶ CommonStore Server on AIX, HP-UX, Linux, Windows, or Sun Solaris
  - Content Manager OnDemand for Multiplatforms V7.1.1 or later (for AIX, HP-UX, Sun Solaris, and Windows)
  - Content Manager OnDemand for iSeries V5.1 or later

- Content Manager OnDemand for z/OS and OS/390 V7.1 or later
- Tivoli Storage Manager V4.1 or later (for AIX, HP-UX, Sun Solaris, Windows, and z/OS)

The CommonStore server software requirements are:

- ▶ CommonStore for SAP is shipped with a correct version of the Java Runtime Environment (JRE™), except in Sun Solaris.
- ▶ On Windows, it requires the SAP graphical user interface.
- ▶ A matching connector. The choice depends on your archive server software:
  - For Content Manager for Multiplatforms V7.1, it requires Content Manager client V7.1 including Fix Pack 1 (7.1.0.1) or later.
  - For Content Manager for Multiplatforms V8.x, Content Manager V8 connector is required. In Content Manager V8.2 and V8.3, this connector is a subcomponent of the IBM Information Integrator for Content (IIC), which is delivered with the product.
  - DB2 Client. For the correct version, see *IBM Content Manager for Multiplatforms: Planning and Installing Your Content Management System*, GC27-1332.
  - For Content Manager OnDemand for Multiplatforms, Content Manager OnDemand for Multiplatforms V7.1.1.0 or later is required. This is the same as the archive server software and because of that, you must install exactly the same version (same package as for the archive server). This is required because the Content Manager OnDemand server software contains the interface to CommonStore, which must exist on the computer where CommonStore for SAP is installed. You do not have to configure this server, and the server hosting your archive can be on a different machine. If you want to install the connector on the same system as the archive server, you do not have to install the package again.
  - For Tivoli Storage Manager, Tivoli Storage Manager API client V4.2 or later is required. To use Tivoli Storage Manager with CommonStore on Linux, API Version 5.2 or later is required.

## 5.4 CommonStore clients

Besides the CommonStore server, the following CommonStore clients are available:

- ▶ 5.4.1, “CommonStore archiving client” on page 123
- ▶ 5.4.2, “CommonStore Viewing Client” on page 124
- ▶ 5.4.3, “CommonStore Utility Client” on page 125

Each CommonStore for SAP Client is delivered in an installation package of its own. All CommonStore clients require a running CommonStore Server for request processing.

### 5.4.1 CommonStore archiving client

The CommonStore Archiving Client is used for the entire communication between the SAP GUI with the archiving system on 32-bit Windows systems. It is needed only for archiving incoming documents. With the CommonStore Archiving Client, scanned documents are archived in combination with SAP. The CommonStore Archiving Client supports the following archiving methods:

- ▶ Early archiving with OLE (using OLE or RFC call) or without OLE  
This means that incoming documents are scanned as soon as they arrive. The documents are archived from a scan workstation that runs the CommonStore Archiving Client, which continuously creates work items in the SAP workflow. Later, an operator enters the booking.
- ▶ Late archiving using bar codes or OLE  
Incoming documents are routed in paper format through the company. An operator enters the booking, applies a bar code on the paper, and sends the paper document to the archiving department where the documents are scanned. The bar code is recognized by the scanning software. Using the CommonStore Archiving Client, the documents are archived and the bar code is sent to SAP, which links the document to the booking.
- ▶ Simultaneous archiving  
Incoming documents are archived when an operator creates the booking. Therefore, the clerk works with a split screen. On one side is the SAP GUI (enter the booking) and on the other is the CommonStore Archiving Client (select the corresponding document). After the clerk enters the booking, the document is archived and linked automatically.

The CommonStore archiving client can handle documents from the following sources:

- ▶ File system (DirQueue)
- ▶ Kofax Ascent Capture Release Module (FileQueue)
- ▶ Content Manager workbaskets (CMQueue)

The CommonStore Archiving Client can archive documents (using the CommonStore Server) into the supported archive systems:

- ▶ Tivoli Storage Manager
- ▶ Content Manager
- ▶ Content Manager OnDemand

The CommonStore Archiving Client requires the following hardware and software:

- ▶ Intel Pentium® 800 MHz processor or equivalent with 512 MB RAM
- ▶ Windows 2000 with Service Pack 1 (or higher) or Windows XP
- ▶ Microsoft Internet Explorer® 5.5 or higher
- ▶ Microsoft Internet Explorer plug-ins for different document types
- ▶ CommonStore Server V8.1 or higher

## 5.4.2 CommonStore Viewing Client

The CommonStore Viewing Client is used for viewing SAP documents with a customized external viewer, for example, a Web browser or the Wang Image Viewer™, by means of Object Linking and Embedding (OLE).

The CommonStore Viewing Client processes the communication:

- ▶ With SAP using OLE
- ▶ With the CommonStore Server using sockets

As shown in Figure 5-2 on page 125, the CommonStore Viewing Client allows external viewers (Alternative 2) other than the standard ArchiveLink Viewer (Alternative 1) provided by the SAP System.



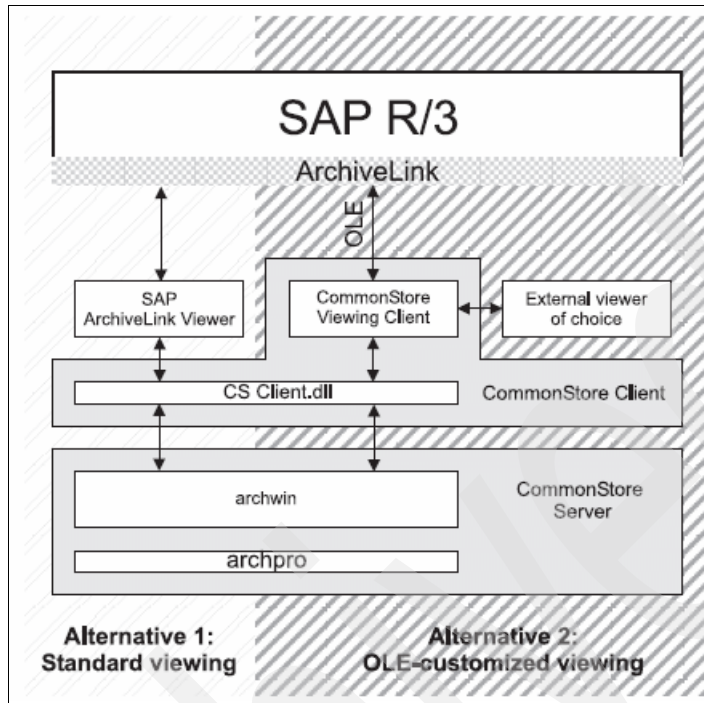

Figure 5-2 CommonStore Viewing Client

The CommonStore Viewing Client requires the following hardware and software:

- ▶ Intel Pentium 800 MHz processor or equivalent with 512 MB RAM
- ▶ Windows 2000 with Service Pack 1 (or higher) or Windows XP
- ▶ Microsoft Internet Explorer 5.5 or higher
- ▶ Microsoft Internet Explorer plug-ins for different document types
- ▶ CommonStore Server V8.1 or higher

### 5.4.3 CommonStore Utility Client

The CommonStore Utility Client is used for transferring search index information from SAP and adding it to already archived documents. The workflow functionality allows you to add archiving information to workflow processes in Content Manager.

The CommonStore Utility Client only works with DB2 Content Manager V8.2 (or higher), both on distributed and z/OS platform.

The CommonStore Utility Client requires the following hardware and software:

- ▶ Intel Pentium 800 MHz processor or equivalent with 512 MB RAM.
- ▶ 10 MB of disk space for the installation. The required temporary disk space varies, depending on the workload and the size of trace and log files.
- ▶ One of the following operating systems:
  - AIX
  - Linux
  - Microsoft Windows 2000
  - Microsoft Windows XP
  - Microsoft Windows Server 2003
  - Sun Solaris
- ▶ For Sun Solaris only: Java Runtime Environment (JRE), Version 1.4.2 or later.

**Note:** For all other operating systems, a JRE is installed automatically with the CommonStore Utility Client.

- ▶ For Windows operating systems only: SAP graphical user interface (SAP GUI).

## 5.5 References

The following references provide more information:

- ▶ DB2 CommonStore for SAP Version 8.3 manuals:  
[http://www-01.ibm.com/support/docview.wss?rs=51&context=SS6QJP&dc=DA400&uid=swg27007919&loc=en\\_US&cs=UTF-8&lang=en&rss=ct51db2](http://www-01.ibm.com/support/docview.wss?rs=51&context=SS6QJP&dc=DA400&uid=swg27007919&loc=en_US&cs=UTF-8&lang=en&rss=ct51db2)
- ▶ *DB2 CommonStore for SAP Client V8.3 Installation and User's Guide*, SH12-6743:  
<http://publibfp.boulder.ibm.com/epubs/pdf/h1267433.pdf>
- ▶ *DB2 CommonStore for SAP Server V8.3 Installation and User's Guide*, SH12-6744:  
<http://publibfp.boulder.ibm.com/epubs/pdf/h1267443.pdf>
- ▶ IBM CommonStore site:  
<http://www-01.ibm.com/software/data/commonstore/sap/>
- ▶ CommonStore brochure:  
<ftp://ftp.software.ibm.com/software/data/cmgr/pdf/cssapv82.pdf>

# Database backup and recovery tools

This chapter provides an overview of database backup tools and techniques that can be used to back up SAP data. The chapter also discusses the features of the the particular backup tools and the best practices that can be used to ensure the appropriate security and availability of data. The evaluation of these tools should help database administrators make decisions about the backup technology that is achievable and acceptable for the application owner.

The chapter covers the following topics:

- ▶ 6.1, “Database backup and recovery tools” on page 128
- ▶ 6.2, “SAP BR\*Tools for Oracle” on page 133
- ▶ 6.3, “Oracle Recovery Manager (RMAN)” on page 145
- ▶ 6.4, “IBM DB2 UDB backup recovery tools” on page 157
- ▶ 6.5, “SAP MaxDB backup recovery tools” on page 172
- ▶ 6.6, “Summary of backup tools” on page 182

## 6.1 Database backup and recovery tools

Database backup and recovery tools (backup managers) provide the functions to control backup and recovery of databases in case of media failure, logical failure, or a disaster. In addition to database recoverability, backup and restore tools can assist in other administration tasks, such as database cloning and data migration.

Backup and recovery tools are either an integrated component of a relational database system, such as Oracle Recovery Manager (RMAN), DB2 backup/restore functions, or may be installed as an independent software package developed by a third party (such as SAP BR\*Tools for Oracle).

Aside from performing backup and recovery operations, backup managers integrated with media management systems can manage and enforce backup storage policies and backup retention policies. The backup retention policies control retention and deletion of backup versions stored on the backup media. Backup storage policies determine the destination media to be used for the particular backup objects, such as backup images of tablespaces, and backups of archived logs can be stored on different media, as dictated by the storage policy.

The basic functions supported by the backup management tools allow you to:

- ▶ Automate data protection tasks and allow for backup of database objects utilizing various methods and techniques (such as online or offline backup and full or partial backup).
- ▶ Provide automatic/semi-automatic restore and recovery functions specific to a particular RDBMS. A backup repository is used for the decision making about which backup image to restore (for example, backup manager picks the last version of full backup and determines which archive redo log backups will be needed for roll-forward recovery).
- ▶ Use a backup repository to keep track of the location of backup images and their time stamps. The information from the backup repository is retrieved whenever the user sends a list of the history of backup operations. The backup repository records are also used whenever backup manager has to determine which backup objects will be retrieved during the automatic database restore or recovery.
- ▶ Control the retention and expiration of backup versions according to retention policies. The retention policy may be defined by either the number of days the backup objects are to be retained or by a number of backup versions to be kept.

Database managers provide interfaces to transfer backup data to backup media or third-party media management systems such as IBM Tivoli Storage Manager. The media interfaces are based either on open standards (such as DB2 XBSA) or can be specific for the particular RDBMS (such as BR\*Tools BACKINT interface or Oracle RMAN SBT interface). Interface adapters for particular backup management systems are developed by the media management systems vendors. This conceptual relationship is shown in Figure 6-1.

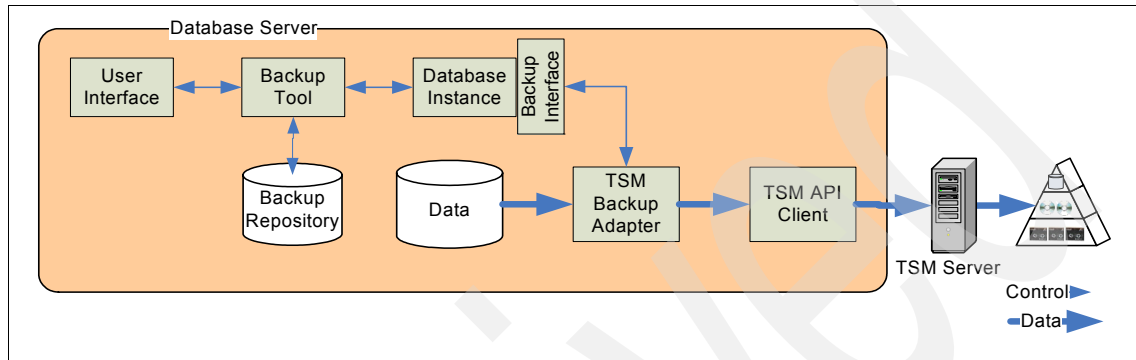

Figure 6-1 System architecture: database backup adapters for Tivoli Storage Manager

Backup adapters for IBM Tivoli Storage Manager are installed as part of the software packages Tivoli Storage Manager for Databases or Tivoli Storage Manager for Enterprise Resource Planning (formerly known as Tivoli Data Protection modules). Those Tivoli Storage Manager backup solutions include backup adapters based on the shared libraries. The backup adapters are compatible with the interfaces of database backup tools. The Tivoli Storage Manager backup adapter is called (or dynamically linked) by the backup management component of the database using the backup interface. The backup adapter communicates with the Tivoli Storage Manager server through the Tivoli Storage Manager client application program interface (API). The basic functions provided by backup adapters are transfer the backup objects to and from the Tivoli Storage Manager server, instruct the Tivoli Storage Manager server to delete the selected backup objects, and retrieve information about the backup objects.

**Note:** IBM DB2 UDB provides integrated Tivoli Storage Manager backup support, so it can directly call the Tivoli Storage Manager API client to transfer data to Tivoli Storage Manager server.

The following Tivoli Storage Manager clients provide backup adapters for Oracle, MS SQL, IBM DB2 UDB, and SAP MaxDB databases:

- ▶ General purpose Tivoli Storage Manager backup adapters for databases:
  - IBM Tivoli Storage Manager for Databases - Oracle: Tivoli Storage Manager backup adapter for Oracle RMAN implements Oracle Media Management API, Secure Backup to Tape (SBT) API V2.0.
  - IBM Tivoli Storage Manager for Databases - Microsoft SQL Server: Tivoli Storage Manager adapter for Microsoft SQL Server implements Microsoft SQL Server Virtual Device Interface (VDI), which enables the Microsoft SQL backups to be transferred to Tivoli Storage Manager server. It supports both earlier and VSS backups.
  - IBM DB2 built-in Tivoli Storage Manager support - DB2 UDB provides an integrated support for Tivoli Storage Manager. Thus, the Tivoli Storage Manager API client is the only component that is required to enable transfers of DB2 backup data to the Tivoli Storage Manager server.
- ▶ SAP-oriented Tivoli Storage Manager backup adapters for databases:
  - Tivoli Storage Manager for ERP - Oracle: This software package implements the Tivoli Storage Manager backup adapters for Oracle RMAN (SBTAPI) and for SAP BR\*Tools (BACKINT). Tivoli Storage Manager for ERP (Oracle) can serve either as a backup adapter between SAP BR\*Tools and Tivoli Storage Manager server or as a backup adapter between Oracle RMAN and Tivoli Storage Manager server. Note that Tivoli Storage Manager for ERP DOES NOT support SAP MaxDB. It only supports DB2 and Oracle as described correctly in the product documentation.
  - Tivoli Storage Manager for ERP - DB2: Implements shared libraries that can integrate DB2 UDB backup tools with Tivoli Storage Manager server.
  - IBM ADINT/TSM: The Tivoli Storage Manager adapter is similar to Tivoli Storage Manager for ERP and provides seamless integration with SAP MaxDB backup/restore/recover utilities. ADINT/TSM is a service offering with central hotline support sold by Tivoli Services organisations in the countries. For more information pls refer to [http://www-05.ibm.com/de/entwicklung/adint\\_tsm/](http://www-05.ibm.com/de/entwicklung/adint_tsm/) .

SAP-oriented Tivoli Storage Manager adapters support additional functions specific to the SAP environment. You can integrate Tivoli Storage Manager for ERP clients with Administration Center, which serves as a solution for the central administration of database backup/recovery tasks. The Administration Center includes productivity tools such as a configuration manager, a performance monitor, operation monitoring, backup recovery simulation, and bottleneck analysis for tuning, cloning support, and reporting. These functions are intended

to relieve the administrator of repetitive tasks and to help manage and optimize the overall backup and recovery process.

Table 6-1 Summary of Tivoli Storage Manager adapters for DB2 UDB, Oracle, and MaxDB

Adapter or backup tool	DB2 UDB	Oracle RMAN	SAP BR*Tools for Oracle	SAP MaxDB
Built-in Tivoli Storage Manager Support	Yes (API)	N/A	N/A	N/A
Tivoli Storage Manager for Databases (Oracle)	N/A	Yes (SBTAPI)	N/A	N/A
Tivoli Storage Manager for ERP (DB2)	Yes (API)	N/A	N/A	N/A
Tivoli Storage Manager for ERP (Oracle)	N/A	Yes (SBTAPI)	Yes (BACKINT)	See the note below
ADINT/TSM	N/A	N/A	N/A	Yes (ADINT)

**Important:** Tivoli Storage Manager for ERP does not support SAP MaxDB. It only supports DB2 and Oracle.

All the backup solutions mentioned above can be integrated with the advanced backup techniques such as LAN-free backup, parallel transfer of backup data to and from Tivoli Storage Manager server, or multiplexing. Implementation of these techniques can significantly reduce backup and restore times and eliminate the impact of backup data transfers on LAN throughput.

**Tip:** Tivoli Storage Manager for ERP can be integrated with Tivoli Storage Manager for Advanced Copy Services (TDP for FlashCopy Devices for mySAP). The integration provides for consistent user interfaces and coherent process flow of backup and restore between direct (tape) and FlashCopy (disk or tape) techniques.

For more specific information about this topic, refer to the corresponding Tivoli Storage Management Product Web site:

- ▶ Tivoli Storage Manager for Enterprise Resource Planning:  
<http://www-01.ibm.com/software/tivoli/products/storage-mgr-erp/>
- ▶ IBM ADINT/TSM:  
[http://www-05.ibm.com/de/entwicklung/adint\\_tsm/index.html](http://www-05.ibm.com/de/entwicklung/adint_tsm/index.html)

- ▶ Tivoli Storage Manager for Databases:

<http://www-01.ibm.com/software/sysmgmt/products/support/IBMTivoliStorageManagerforDatabases.html>



- ▶ Tivoli Storage Manager for Advanced Copy Services:  
<http://www-01.ibm.com/software/tivoli/products/storage-mgr-advanced-copy-services/>
- ▶ IBM FlashCopy Cloning of SAP Databases:  
<http://www-05.ibm.com/de/entwicklung/esd/fcc/>

## 6.2 SAP BR\*Tools for Oracle

The BR\*Tools for Oracle is a package of utilities developed by SAP AG to protect and manage SAP data stored in Oracle databases. BR\*Tools supports functions for online or offline, partial or full backups of database (BRBACKUP) and backup of archived redo logs (BRARCHIVE). It provides functions for database restore and recovery (BRRECOVER and BRRESTORE). BR\*Tools can be used not only for database recoverability tasks, but it can also serve as a tool for creating homogenous database copies and can assist with database migration to different platforms or database versions.

**Note:** BR\*Tools replaced the functionality of SAPDBA used in older versions of SAP. SAPDBA is no longer being developed. BR\*Tools in Version 7 provides an enhanced functionality that exploits the features of Oracle 10g:

- ▶ System copy based on Oracle Transportable Tablespace feature.
- ▶ Support for Oracle Flashback feature:
  - Restore points can be defined from BR\*Tools.
  - Point-in-time restore using Restore Points.
- ▶ Archive logs can be verified by RMAN before being backed up.

This discussion in this section covers:

- ▶ 6.2.1, “User interfaces” on page 134
- ▶ 6.2.2, “Backup control function” on page 134
- ▶ 6.2.3, “Archived redo log backup functions” on page 136
- ▶ 6.2.4, “Restore and recovery functions” on page 137
- ▶ 6.2.5, “Media interfaces” on page 139
- ▶ 6.2.6, “Backup repository” on page 140
- ▶ 6.2.7, “BR\*Tools and Tivoli Storage Manager for ERP - Oracle” on page 140
- ▶ 6.2.8, “References” on page 145

## 6.2.1 User interfaces

BR\*Tools backup and restore functions can be accessed either from the user interface (run the **BRGUI** command to use GUI or **BRTTOOLS** to use the command line) or directly from the command line or script by executing the commands **BRBACKUP**, **BRARCHIVE**, **BRRESTORE**, and **BRRECOVER**. You can also execute BR\*Tools backup/restore functions from the Computing Center Management System (CCMS). The BR\*Tools executables are located in the `/sap/<SID>/SYS/exe/run` directory. Example 6-1 shows an example result of the **BRTTOOLS** command.

*Example 6-1 BR\*Tools console interface*

---

```
BR0651I BRTTOOLS 7.00 (32)

BR0280I BRTTOOLS time stamp: 2008-09-26 18.07.11
BR0656I Choice menu 1 - please make a selection
-----
BR*Tools main menu

  1 = Instance management
  2 - Space management
  3 - Segment management
  4 - Backup and database copy
  5 - Restore and recovery
  6 - Check and verification
  7 - Database statistics
  8 - Additional functions
  9 - Exit program

Standard keys: c - cont, b - back, s - stop, r - refr, h - help
-----
BR0662I Enter your choice:
```

---

## 6.2.2 Backup control function

**BRBACKUP** is the BR\*Tools utility that enables online or offline backup of database files (data files, control files, and online redo log files). **BRBACKUP** can be used to backup individual data files, tablespaces, or the entire Oracle database. **BRBACKUP** also backs up the BR\*Tools configuration profiles and logs that are required for the database's disaster recovery.

Before the offline backup, BRBACKUP automatically closes the database and opens it as soon as the backup is accomplished. BRBACKUP can also change the status of the tablespace to be backed up to BEGIN/END BACKUP.

You can also instruct BRBACKUP to use software compression. The software compression client could enhance the backup, especially if the network is slow. If you plan to enable software compression for sending backup data to a tape storage pool on the Tivoli Storage Manager server, you should consider disabling hardware compression.

**Note:** BRBACKUP supports incremental backups only when configured to use Oracle RMAN as an interface. The integration of RMAN into BRBACKUP is limited to cumulative incremental backups at level 1.

The most frequently used BRBACKUP function is a full database backup. You can perform a full backup by running BRBACKUP with the following options:

- ▶ The mode option (-mode/-m) is set to FULL or ALL.
- ▶ You can start a full backup either in online mode (-type/-t online\_cons) or in offline mode (-type offline). In case of the online\_cons type, the offline redo log files generated during the full backup are also backed up to the same media.
- ▶ The backup storage media is defined by the BR\*Tools profile file specified by the BRBACKUP parameter -profile/-p.
- ▶ The user name and password used by BRBACKUP to log on the Oracle database system is specified by the parameter -user/-u. If you are working as a DBA authenticated to the database by the OS (\$OPSuser), you can just use "/" as value of this parameter.
- ▶ The parameter "-confirm/-c" stands for an unattended mode. This is mostly used in the backup scripts, so BRTOOLS will not prompt you for confirmations.

Example 6-2 shows an example invocation of BRBACKUP.

*Example 6-2 Online backup using the databases BRBACKUP tool*

---

```
$su - cptadm  
$BRBACKUP -c -u / -t ONLINE_CONS -m FULL -p  
/oracle/CPT/102_64/dbs/initCPT.sap
```

---

**Note:** In addition to backup data files, BRBACKUP can be used to back up other files and directories, such as SAP binary files. However, BRBACKUP is not an optimal tool to back up a large quantity of small files. To back up non-database files, Tivoli Storage Manager Backup/Archive Client should be used.

### 6.2.3 Archived redo log backup functions

BRARCHIVE provides functions for offline redo log files backup in Oracle databases running in archiving mode.

If archiving is enabled, a database cannot overwrite an active log file until the content has been archived. Whenever an active redo log is completely filled, the database performs a log switch and starts writing to another log file. The filled redo log files are archived by Oracle background processes into the archive log directory.

The redo log is the most important database component for a recovery from a crash, media failure, or user failure. Therefore, at least the production databases should be configured in archiving mode. To prevent the archive log directory from filling up, BRARCHIVE should be executed periodically to move the offline redo logs from the the archive directory to the backup media.

The most common use of BRARCHIVE is to back up the offline redo log files to backup storage and delete the backed up log files from the archive log directory. This function is invoked by calling BRARCHIVE with the parameter -sd.

Example 6-3 shows a sample invocation of BRARCHIVE.

*Example 6-3 Backup of redo log by BRARCHIVE and its removal from the local storage*

---

```
$su - orcadm  
$BRARCHIVE -c -u / -sd -p /oracle/ORC/102_64/dbs/initORC.sap
```

---

In addition to data files and redo logs, BRBACKUP and BRARCHIVE can also back up the following objects:

- ▶ BR\*Tools profiles init<SID>.ora and init<SID>.dba
- ▶ The BRBACKUP and BRARCHIVE logs
- ▶ The summary BRSPACE log space<SID>.log, the log of database structure changes struc<SID>.log, and the log of database parameter changes param<SID>.log.

## 6.2.4 Restore and recovery functions

You can trigger all the available restore and recovery functions from the BR\*Tools console menu. You can open the BR\*Tools console by logging in as the SAP system admin (<sid>adm). From the command line, execute command **brtools** with no parameters. The menu shown in Example 6-4 should appear.

*Example 6-4 BR\*Tools main menu*

---

```
charger01:orcadm 2> brtools
BR0651I BRT0OLS 7.00 (32)

BR0280I BRT0OLS time stamp: 2008-09-30 16.52.25
BR0656I Choice menu 1 - please make a selection
-----
BR*Tools main menu

  1 = Instance management
  2 - Space management
  3 - Segment management
  4 - Backup and database copy
  5 - Restore and recovery
  6 - Check and verification
  7 - Database statistics
  8 - Additional functions
  9 - Exit program

Standard keys: c - cont, b - back, s - stop, r - refr, h - help
-----
BR0662I Enter your choice:
```

---

The restore and recovery function is provided under menu number 5 (see Example 6-5). Press 5 and Enter.

*Example 6-5 BR\*Tools Restore and recovery menu*

---

```
BR0280I BRT0OLS time stamp: 2008-09-30 16.56.45
BR0656I Choice menu 11 - please make a selection
-----
Restore and recovery

  1 = Complete database recovery
  2 - Database point-in-time recovery
  3 - Tablespace point-in-time recovery
  4 - Whole database reset
  5 - Restore of individual backup files
```

- 6 - Restore and application of archivelog files
- 7 - Disaster recovery
- 8 - Reset program status

Standard keys: c - cont, b - back, s - stop, r - refr, h - help

-----  
BR0662I Enter your choice:  
-----

The BR\*Tools restore and recovery menu allows you to perform the restore tasks, as shown in Example 6-5 on page 137.

The restore and recovery functions available in the BR\*Tools menu are as follows:

▶ 1 - Complete database recovery

This function is used to restore and recover (to the time of failure) the entire Oracle database. Typically, this command is used if the data files have been lost due to a media error. This function:

- Restores the missing data files from backup media
- Performs the database recovery to the time of failure

▶ 2 - Database point-in-time recovery

Point in time recovery is used to restore and recover database to a specified point in time. Typically, this option is used in case of data corruption due to user error.

▶ 3 - Tablespace point-in-time recovery

This function provides the same function as the previous one. One or more tablespaces can be selected for this type of restore and recovery.

▶ 4 - Whole database reset

This command allows you to reset an Oracle database after a failure. Typically, you have to perform a database reset in the following situations:

- All copies of the redo log files have been lost due to an error, but a backup of the data files is available.
- You performed a complete offline backup or a consistent online backup immediately before the failure.

With this function you can reset the database to a consistent state, either to a point in time of the complete offline backup or to a point in time of the consistent online backup.

▶ 7 - Disaster recovery

This option is used to restore an Oracle database in case the entire SAP system has been lost and there are not any other options to recover it. The only components required for BR\*Tools disaster recovery are:

- The SAP system and Oracle database must be installed.
- The file system `.../sapdataX/` has to be recreated.

Options 5 and 6 are considered advanced options. For additional information about these functions, refer to the SAP BR\*Tools documentation.

The BR\*Tools restore and recovery tasks are mostly executed from the BRTOOLS menu. However, you have the option to call the BRRESTORE and BRRECOVER tools directly from the command line:

- ▶ BRRESTORE is used to restore the whole database or parts of it (data files, control files, and archive redo log files). BRRESTORE can be run directly from a command line and is also called by the BRRECOVER program when it performs automatic database recovery. Before BRRESTORE starts placing the data files back into the file system, it determines whether there is the appropriate free space on the file system. In addition to restoring data files, BRRESTORE recovers the directories and links. The only prerequisite for executing restore is the directory `$SAPDATA_HOME` and the `sapdata<x>` subdirectories (mount points).
- ▶ BRRECOVER is a BR\*Tools component used for database restore and recovery after media errors, user errors, or disasters occur and the entire database has to be restored, including backup profiles and logs. BRRECOVER can be used to recover either the entire database (complete database recovery, disaster recovery, or database point-in-time recovery) or part of the database (tablespace point-in-time recovery, individual data files restore, or restore and application of backed up archive redo log files). To restore data files, BRRECOVER calls the utility BRRESTORE.

## 6.2.5 Media interfaces

The BR\*Tools backup media is specified by the settings in the initialization profile. Backups performed by BR\*Tools can be transferred to a backup media by the following interfaces:

- ▶ The commands `cpio` and `dd` (or, in Windows environment, using the MKS toolkit).
- ▶ BACKINT: An universal interface for external backup and tape management systems, such as Tivoli Storage Manager. The BACKINT adapters for a particular media management systems are developed by vendors of the media management systems.

- ▶ Oracle RMAN: By integrating BR\*Tools with Oracle RMAN, BR\*Tools can utilize RMAN backup and restore functions. In this configuration, BR\*Tools allocates a dynamic RMAN SBT channel and uses it to transfer backup data to a backup media of the channel.

**Note:** Both the adapters SBT API for RMAN and BACKINT for BR\*Tools are included in Tivoli Storage Manager for ERP (Oracle) installation package. Thus, BR\*Tools can transfer data to the Tivoli Storage Manager server either directly through BACKINT or indirectly through the RMAN channel configured to use Tivoli Storage Manager SBT API. In both of these configurations, BR\*Tools employs BACKINT to back up its profiles and logs to a Tivoli Storage Manager server.

## 6.2.6 Backup repository

BR\*Tools backup meta data is stored in BR\*Tools log files. BR\*Tools uses the records in the logs to analyze the best restore option. From the log files, it can determine the location and time stamps of backup objects that could be used for automatic or point-in-time recovery. The backup repository is backed up together with a database when using the BRBACKUP tool.

The log files are located in the following directories:

- ▶ <SAPDATA\_HOME>\sapbackup (the BR\*Tools logs associated with data file backup functions)
- ▶ <SAPDATA\_HOME>\saparch (the BR\*Tools logs associated with redo log backup tasks)

## 6.2.7 BR\*Tools and Tivoli Storage Manager for ERP - Oracle

BR\*Tools interacts with Tivoli Storage Manager for ERP - Oracle through the BACKINT interface. The communication of BR\*Tools and BACKINT proceeds as follows:

1. The BR\*Tools utility BRBACKUP informs Oracle what data has to be backed up and puts the database into the proper backup state (online or offline backup).
2. BRBACKUP calls Data Protection for SAP using the BACKINT interface with a list of all files to be backed up.
3. Data Protection for SAP reads all requested files from the database and reports back to BRBACKUP. BRBACKUP adds these files to the repository containing all processed backups.



4. BACKINT transfers the data to Tivoli Storage Manager server using the Tivoli Storage Manager Client API.
5. The BR\*Tools updates the repository containing information about the status of the files.

**Note:** If `cpio`, `dd`, or the BACKINT interface is used, BRBACKUP sets the tablespaces to backup status before it is copied to the backup media. As soon as the backup is finished, BRBACKUP switches the tablespaces back to normal mode. The backup status of tablespaces may lead to an extensive generation of redo log data. This may lead to a problem in the tablespace that is known as fractured blocks.

The RMAN backup function copies data blocks while the tablespace stays in normal mode. Thus, if you use Oracle RMAN integrated with BR\*Tools, the extensive log writing issue does not occur.

The BACKINT adapter is an executable that provides the interface between BR\*Tools and an external media management system. The BACKINT adapter supports the following functions:

- ▶ **BACKUP:** The backup function defines a backup request, including all the files specified in a list. If the backup request cannot be processed completely, the interface informs the user which files have been backed up successfully (partial backup). The sequence in which the files are saved can be freely determined by the external backup utility. If backup starts, the external backup/restore interface program generates a unique backup ID (BID) for a set of saved files in one session, which clearly identifies the backup. This BID will be given to the appropriate SAP database utility at the end of a backup run.
- ▶ **RESTORE:** The restore function is used to pass on a restore request to the external backup/restore interface program. This request consists of a user ID, backup IDs, a list of files to be restored, and a list of directories where files should be created. The last parameter is optional. If the backup ID is not set, the last backup of the related file is used. The return information indicates which files have been restored successfully and which backup IDs have been used.
- ▶ **INQUIRE:** The inquire function provides information about the backups managed by the external backup/restore interface program. This function is called using the UID, BID, and the file name (the last two parameters are optional). If the BID is not set, a list of available backups (BIDs) is provided, which includes the specified file. If a file name is not specified, a list of files belonging to a specific BID is generated.

- ▶ **DELETE:** The delete function is used to inform Backint for SAP DB about previously saved files or pipes, which are to be deleted or expired. The files or pipes that are not needed any longer are specified by their UID, BID, and name.

## Configuration

The BR\*Tools configuration is stored in the initialization profile file `init<SID>.sap`. The configuration file contains parameters that affect the performance of backup and restore functions. The default location of the file is `<ORACLE_HOME>/dbs` (UNIX) or `<ORACLE_HOME>\database` (Windows). Some parameters specified in the profile can be overridden if the BR\*Tools programs are called with different command options. In the BR\*Tools profile, you can specify the backup adapter that will be used to transfer data (**cpio**, **BACKINT**, or **RMAN**).

If you set up BR\*Tools to use the **BACKINT** adapter, you have to reference the appropriate **BACKINT** profile (\*.utl file) in the BR\*Tools profile. If you want to instruct BR\*Tools to use Oracle **RMAN**, you also have to define the **RMAN** channel parameters in the BR\*Tools profile.

The configuration profile of Tivoli Storage Manager for ERP is defined in the file `init<SID>.utl`, which is usually located in the same directory as the BR\*Tools profile (`init<SID>.sap`). The configuration parameters in `init<SID>.utl` include Tivoli Storage Manager node name and the management classes to be used for data files backup and offline redo logs backup. If the backup retention is going to be controlled by Tivoli Storage Manager for ERP, you can set up the number of backup versions to be kept in this file.

The configuration file of the Tivoli Storage Manager API (`dsm.sys`) is, by default, stored in the Tivoli Storage Manager API installation directory (specified by the environmental variable `DSMI_DIR`). The configuration file of the Tivoli Storage Manager API Client defines the network settings (protocol and network address of the Tivoli Storage Manager server) to enable communication between the API Client and the Tivoli Storage Manager server. You also specify in this file the authentication type (**PASSWORDACCESS**) that the Tivoli Storage Manager API client will use to connect to the Tivoli Storage Manager server. Additionally, if the Storage Agent is operable on the local node in this file, you can instruct Tivoli Storage Manager API Client to use the LAN-free backup (using the **LANFREE yes/no** option).

You can perform the following steps to configure BR\*Tools to use the Tivoli Storage Manager BACKINT adapter with Tivoli Storage Manager for ERP:

- ▶ On the Tivoli Storage Manager server:
  - a. Define a policy domain with two management classes that will be used to transfer data and logs. Define an archive copy group for each of the management classes. If the retention control will be performed at the Tivoli Storage Manager server, specify `RETVER=<days>` for the number of days for each archive copy group. If retention control will be performed at the Tivoli Storage Manager for ERP level, specify `RETVER=nolimit`.
  - b. Register the Tivoli Storage Manager node with the defined domain. Update the parameter `MAXNUMMP` for the Tivoli Storage Manager node to `MAXNUMMP=2` (based on the parallelism required).
- ▶ On the client node:
  - a. Update or create `dsm.sys` for the Tivoli Storage Manager API client. The parameter `PASSWORDACCESS=PROMPT` must be set for this configuration.
  - b. Configure the environment values `DSMI_DIR` and `DSMI_LOG` for the Oracle user. the Tivoli Storage Manager API client looks for the `dsm.sys` configuration file in the directory specified by `DSMI_DIR`.
  - c. Install Tivoli Storage Manager for ERP - Oracle on the Oracle server, with SAP already installed. The installation wizard lets you specify the name of Tivoli Storage Manager server stanza in `dsm.sys`, the Tivoli Storage Manager node name, and the management classes to be used for backup of data and archived logs.
  - d. Configure the client resources for Oracle server in the Tivoli Storage Manager for ERP configuration file (`<ORACLE_HOME>\dbs\init<SID>.utl`). Check the defined Tivoli Storage Manager node name and Tivoli Storage Manager management classes to be used for the backup of offline redo log files and data files. Make sure that the `SERVER` parameter refers to an existing stanza in the `dsm.sys` file. If the retention control will be driven by Tivoli Storage Manager for ERP, set up the `MAX_VERSIONS` parameter.
  - e. Switch the user to the Oracle instance owner and update the password of the Tivoli Storage Manager node using the following command:

```
backint -p <full_path>\init<SID>.utl -f password
```
  - f. Instruct BR\*Tools to use the BACKINT interface by setting the `backup_dev_type` parameter in the SAP initialization file (`init<SID>.sap`) as follows:

```
backup_dev_type = util_file
```

- g. Instruct BR\*Tools to use the file `init<SID>.utl` (created by Tivoli Storage Manager for ERP installation wizard) by setting the `util_par_file` parameter in the SAP initialization file:

```
util_par_file=<full_path>/init<SID>.utl
```

For more specific information about this setup, refer to the *Data Protection for SAP - Installation and User's Guide*, SC33-6340.

**Note:** Tivoli Storage Manager for ERP uses the Tivoli Storage Manager archive functions to transfer data to Tivoli Storage Manager server and vice versa. Thus, the management classes assigned to Tivoli Storage Manager for ERP (`init<SID>.utl`) must have an archive copy group defined.

### Backup retention control

The backup retention policy can be configured either on the Tivoli Storage Manager server side by the archive copy group parameter `RETVER` (the number of days the version is to be kept) or on the side of Tivoli Storage Manager for ERP by specifying the parameter `MAX_VERSIONS` in the configuration profile (`init<SID>.utl`).

The parameter `MAX_VERSIONS` defines the maximum number of database backup versions to be kept in backup storage. The default setting for this value is 0, meaning that backup version control is disabled.

Every time a full backup completes successfully, the version count is incremented by 1 and stored in the DP for SAP configuration file. This value is also assigned to the tablespace files and to all subsequent redo log backups. If the number of versions kept in backup storage is larger than the specified maximum number of backup versions (stored in the parameter `MAX_VERSIONS`), the oldest versions are deleted (together with the corresponding tablespace and redo log files) until only the specified maximum number of most recent versions remain.

A Tivoli Storage Manager server uses the value of the parameter `RETVER` specified when defining an archive copy group to give files an expiration date. If you use Data Protection for SAP backup version control, you need to bypass this expiration function. If you use the Tivoli Storage Manager expiration function, you need to turn off Data Protection for SAP backup version control. Use only one of these methods to control how long you keep backups.

If you use Data Protection for SAP backup version control, set the Tivoli Storage Manager parameter `RETVER` to `RETVER=9999` so that the files are not considered expired and are not deleted by Tivoli Storage Manager.

If you use Tivoli Storage Manager expiration, deactivate DP for SAP versioning by setting MAX\_VERSIONS=0.

BR\*Tools (BACKINT for Tivoli Storage Manager) can control FlashCopy and FlashBack operations performed by Tivoli Data Protection for FlashCopy Devices for mySAP (Oracle). However, the only mySAP DBA tool that can be used for FlashBack operation is BRRESTORE when started with the -m full option. Other tools, such as SAPDBA, BRTOOLS, and BRRECOVER, are not suited to running a complete database restore because they have no interface that allows a disk-oriented restore.

## 6.2.8 References

See also the following references for more information about the topics in this section:

- ▶ *SAP Netweaver 7.1, Oracle Restore and Recovery, 2008*, found at;  
<https://www.sdn.sap.com/irj/sdn/go/portal/prtroot/docs/library/uuid/97a4f439-0d01-0010-d488-d29b45e2f5ab>
- ▶ *Interface Specification: Oracle Database Administration, BC-BRI BACKINT Interface for Oracle Databases, 2008*, found at;  
<https://www.sdn.sap.com/irj/sdn/go/portal/prtroot/docs/library/uuid/24ae2e3a-0d01-0010-838f-ace2a9154bac>
- ▶ *SAP White Paper: Oracle Database Administration, SAP Database Administration for Oracle, 2008*, found at:  
<https://www.sdn.sap.com/irj/sdn/go/portal/prtroot/docs/library/uuid/20e638fc-a706-2a10-9d82-c40503247d30>
- ▶ *Data Protection for SAP - Installation and User's Guide, SC33-6340*

## 6.3 Oracle Recovery Manager (RMAN)

Recovery Manager (RMAN) is the Oracle proprietary backup and recovery management tool. RMAN is included as a part of Oracle RDBMS and provides users with backup and restore functionality as well as other database management tasks. RMAN can back up data files, archived redo logs, control files, and configuration files (such as the init file, password file, tnsnames.ora, and sqlnet.ora). RMAN supports functions for online or offline and partial or full backup. It also supports an incremental and cumulative incremental backup.

We discuss the following topics in this section:

- ▶ 6.3.1, “User interfaces” on page 146
- ▶ 6.3.2, “Backup control functions” on page 147
- ▶ 6.3.3, “Archive redo log backup functions” on page 148
- ▶ 6.3.4, “Restore and recovery functions” on page 149
- ▶ 6.3.5, “Media interfaces” on page 151
- ▶ 6.3.6, “Backup repository and retention control” on page 152
- ▶ 6.3.7, “Integration of BR\*Tools with Oracle RMAN” on page 153
- ▶ 6.3.8, “References” on page 156

## 6.3.1 User interfaces

RMAN operations can be controlled by the command-line interface or from the Oracle Enterprise Manager GUI. The GUI is shown in Figure 6-2.

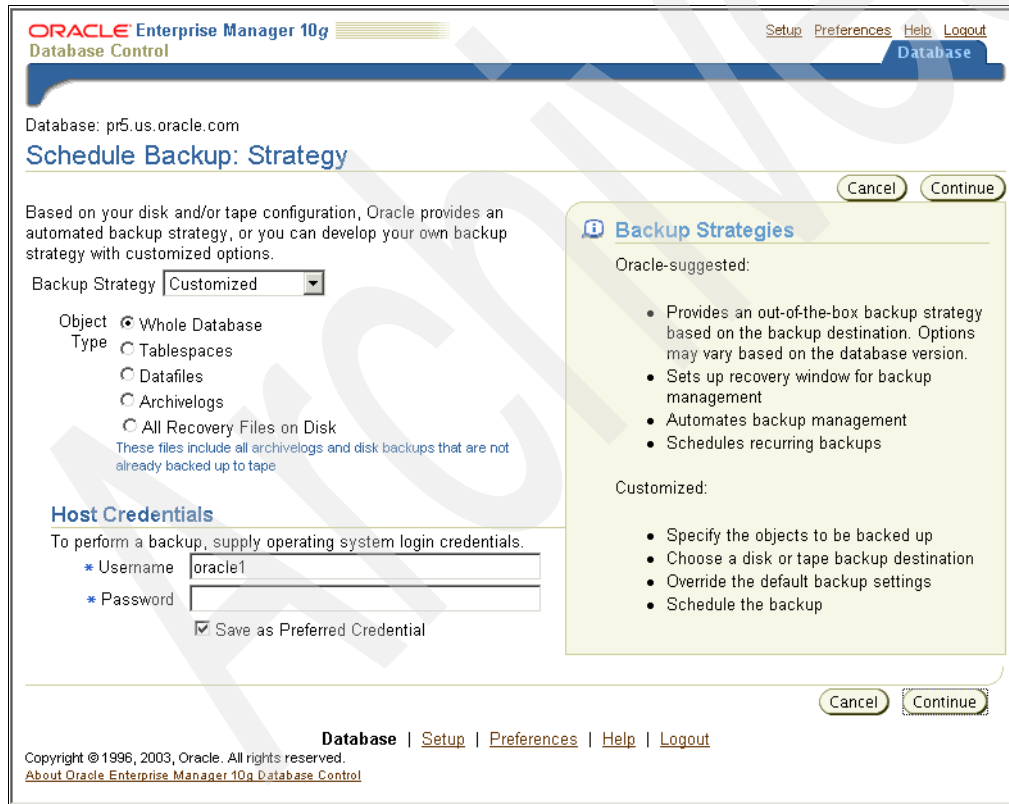

Figure 6-2 Oracle Enterprise Manager: backup/restore

## 6.3.2 Backup control functions

RMAN provides for the following basic backup functions:

- ▶ Online full backup

The RMAN script in Example 6-6 performs Oracle database online (hot) backup. It also backs up redo logs created during the time of the backup. The command **delete obsolete** removes any backups older than 30 days.

*Example 6-6 Oracle online backup using RMAN*

---

```
run {
  allocate channel t1 type 'sbt_tape' parms
  'ENV=(TDPO_OPTFILE=/usr/tivoli/tsm/client/oracle/bin64/tdpo.opt)';
  backup database plus archivelog all delete input;
  delete noprompt obsolete recovery window of 30 days;
}
```

---

In Example 6-6, archived logs are backed up right after the database online backup is made. This ensures that you can restore all the archived logs through the time of backup. Thus, media recovery after restoring the online backup is guaranteed.

- ▶ Offline full backup

The RMAN script in Example 6-7 performs Oracle database offline (cold) backup using the Tivoli Storage Manager media management library.

*Example 6-7 Oracle offline backup using RMAN*

---

```
run {
  allocate channel t1 type 'sbt_tape' parms
  'ENV=(TDPO_OPTFILE=/usr/tivoli/tsm/client/oracle/bin64/tdpo.opt)';
  shutdown;
  startup mount;
  backup database;
  sql 'alter database open';
}
```

---

- ▶ Partial (tablespace or datafile) backup

To back up the selected data file `test.dbf`, run this command:

```
BACKUP DATAFILE '/u01/oracle/oradata/test.dbf';
```

To back up the selected tablespaces `USERS` and `SYSTEM`, run this command:

```
BACKUP TABLESPACE USERS,SYSTEM;
```

- ▶ Incremental backup

RMAN level 0 backup is the base full backup for subsequent incremental backups. The only difference between a level 0 incremental backup and a full backup is that a full backup is never part of an incremental strategy.

To do this type of backup, run this command:

```
BACKUP INCREMENTAL LEVEL 0 DATABASE;
```

RMAN level 1 backup is the incremental backup, either differential or cumulative. A differential backup backs up all database blocks changed after the latest incremental backup at level 1 or 0.

To do this type of backup, run this command:

```
BACKUP INCREMENTAL LEVEL 1 DATABASE;
```

A cumulative backup backs up all database blocks changed after the latest incremental backup at level 0. To do this type of backup, run this command:

```
BACKUP INCREMENTAL LEVEL 1 CUMULATIVE DATABASE;
```

- ▶ Controlfile and configuration files backup

We recommend turning on the parameter “controlfile autobackup”. If controlfile autobackup is enabled, Oracle backs up the Oracle controlfile and parameter file whenever a successful backup record is written in the RMAN repository or whenever a structural change to the database influences the content of the controlfile (such as when a data file is created or resized).

To do this type of backup, run this command:

```
CONFIGURE CONTROLFILE AUTOBACKUP ON;
```

### 6.3.3 Archive redo log backup functions

You can back up archived redo logs with the RMAN command `BACKUP ARCHIVELOG`. Additionally, you can instruct RMAN to back up archived logs after backing up data files and control files by specifying `BACKUP ... PLUS ARCHIVELOG`. By archiving the redo logs immediately after the online backup, you ensure that you have a full set of archived logs through the time of the backup.



Example 6-8 illustrates the backup of offline redo logs that have been generated during the database backups. The redo log backup is performed using the same RMAN channel.

*Example 6-8 Oracle offline redo logs backup using RMAN*

---

```
run {
  allocate channel t1 type 'sbt_tape' parms
  'ENV=(TDPO_OPTFILE=/usr/tivoli/tsm/client/oracle/bin64/tdpo.opt)';
  backup archivelog all delete input;
}
```

---

### 6.3.4 Restore and recovery functions

In addition to the backup functions, RMAN provides functions that can restore the database from backup media and recover the database (or only a tablespace or data file) to the required point in time. The Oracle restore and recovery strategy has many options. For detailed information about restore and recovery using Oracle products, refer to the appropriate Oracle documentation.

**Tip:** Since Version 10g, Oracle database provides a FlashBack database function that can rewind a database to a previous time in order to recover from user errors. This method is less time consuming than the traditional method based on database restore and recovery to a point in time.

When performing database restore or recovery from the Tivoli Storage Manager server, you first have to allocate the RMAN channel based on the Tivoli Storage Manager SBT adapter. As soon as the channel is allocated, you can instruct RMAN to perform the restore or recovery of a database or the restore of control files.

RMAN provides the following basic restore and recovery options:

- ▶ Database full restore: To restore the entire database from the latest backup, run the command **restore database**.
- ▶ Database partial restore: To restore a single tablespace or data file from the last backup, issue one of these commands:  

```
restore datafile <datafile name and the full path>;
restore tablespace <tablespace name>;
```
- ▶ Control file restore from auto backup: RMAN always stores the information on backups (backup repository) in Oracle control files. Additionally, the RMAN catalog can be used as a backup repository storage. If the RMAN catalog is not available and you need to perform restore or recovery of a database,

RMAN will access the control file to determine the location of the backup images that are required by the restore operation. If the control files have been lost due to failure, you have to restore the latest version of the control file backed up by control file autobackup feature. To do so, you have to provide the DBID of the database to be restored.

See Example 6-9 for the necessary commands to perform this type of restore.

*Example 6-9 Restore controlfile from autobackup*

---

```
set dbid <DBID of database>;
startup nomount;
run
{
allocate channel t1 type 'sbt_tape' parms
ENV=(TDPO_OPTFILE=/usr/tivoli/tsm/client/oracle/bin64/tdpo.opt)';
restore controlfile from autobackup;
```

---

- ▶ Database recovery: To perform a complete database recovery, issue the command **recover database**. To perform a database recovery for a given log sequence, use the command **recover database until logseq=<log\_seq#> thread=<log\_thd#>**. To perform a database recovery to a point in time, use the command **recover database until time '2008-05-18:10:10:00'**.

The RMAN script in Example 6-10 presumes that the media failure affected only the database data files. Control files as well as the active redo files remain intact. The failed storage media have been replaced. Therefore, we can perform the full database restore and complete recovery. The example presumes that the full backup of database and offline redo log files was taken regularly before the failure occurred.

*Example 6-10 Restore and complete recovery of Oracle database using RMAN*

---

```
shutdown immediate;
startup nomount;
run
{
allocate channel t1 type 'sbt_tape' parms
'ENV=(TDPO_OPTFILE=/usr/tivoli/tsm/client/oracle/bin64/tdpo.opt)';
restore database;
recover database;
alter database open noresetlogs;
}
```

---

Before the restore operation can start, we have to put the the database into the nomount mode (**startup nomount**). Then we can dynamically allocate the RMAN channel named t1 that uses Tivoli Storage Manager SBT media (**allocate channel**). As soon as the channel is allocated, we execute the database restore function with no parameters. It instructs RMAN to restore all the data files from the last available database backup. As soon as the restore is finished, we have to restore the offline redo logs and apply all the transactions from redo logs that had been performed on the database since the last backup to the time of failure. This is done by using the **recover database** command. Database recovery uses the offline redo logs restored from Tivoli Storage Manager as well as the online redo logs that remained intact to apply the changes. As soon as the database recovery is finished, we can open the database with the `noresetlogs` option, because the active log files have not been affected by the failure and the log files chain has not been interrupted.

### 6.3.5 Media interfaces

RMAN supports several types of backup interfaces called *RMAN channels*. An RMAN channel consists of a single server session at the target database and a data stream from the database to backup device. RMAN sends commands to the database and the server session executes the command on behalf of RMAN.

You can allocate the RMAN channel either manually or it can be allocated automatically. The automatic channel allocation feature is used to configure persistent channels to be used in all RMAN sessions. When a persistent channel is set up, there is no need for manual channel allocation every time backup or restore functions are called. When you run a function that requires a channel, and no channels have been allocated manually, RMAN automatically allocates a persistent channel.

The manual channel allocation is used to define *ad hoc* channels for commands within the RMAN run block (script). A manual channel can be set up either by the **ALLOCATE CHANNEL** command or **ALLOCATE CHANNEL FOR MAINTENANCE** command. By manually allocating a channel, you can override automatic channel allocation settings.

RMAN supports these types of media devices for the channel allocation:

- ▶ **DISK**: Backup data is placed into a local directory/folder.
- ▶ **SBT (Oracle media management SBTAPI)**: The SBT interface is used to access other vendors' media management systems, such as Tivoli Storage Manager.

You can define the persistent RMAN channel by using the **RMAN CONFIGURE** command, as shown in Example 6-11. The persistent configuration of RMAN is saved in the Oracle control files.

*Example 6-11 Persistent channel definition*

---

```
configure channel device type 'sbt_tape' parms
'ENV=(TDPO_OPTFILE=/opt/tivoli/tsm/client/oracle/bin64/tdpo.opt)';
configure default device type to 'sbt_tape';
```

---

Example 6-12 demonstrates the dynamic channel allocation within the RMAN run block. Channel t1 is allocated to use the Tivoli Storage Manager SBTAPI interface. The backup function is initiated within the same run block after the channel allocation command.

*Example 6-12 Dynamic channel allocation*

---

```
run
{
  allocate channel t1 type 'sbt_tape' parms
'ENV=(TDPO_OPTFILE=/usr/tivoli/tsm/client/oracle/bin64/tdpo.opt)';
  backup database plus archivelog delete input;
}
```

---

### 6.3.6 Backup repository and retention control

The RMAN repository stores the meta data used by RMAN for backup, recovery, and maintenance operations. The repository is stored in the control files. In addition, the RMAN repository may be replicated to a special Oracle database, that is, the RMAN catalog. The repository keeps track of the backup sets and pieces, image copies, proxy copies, the target database schemas, and RMAN persistent configuration settings.

The following are the basic RMAN functions related to the repository:

► LIST

The LIST command displays information about the backup objects recorded in the RMAN repository. The options are:

```
LIST BACKUP;
LIST BACKUP OF DATABASE;
LIST BACKUP OF ARCHIVELOG;
LIST BACKUP SUMMARY;
```

► REPORT

The REPORT OBSOLETE command lists all the backup pieces that are not compliant with the RMAN persistent retention policy settings.

► DELETE

You can control the retention of the backups of data files and redo logs by using the RMAN DELETE command. The DELETE command removes the selected physical backup images and updates the corresponding records in the control file to indicate that the backups have been deleted. The **delete obsolete** command removes any backup pieces that are not compliant with the RMAN persistent retention settings.

If the persistent retention policy is not set up, you can use the DELETE OBSOLETE REDUNDANCY=30 commands to delete the obsolete backup versions older than 30 versions. To delete backup images older than 30 days, use the command DELETE OBSOLETE RECOVERY WINDOW OF 30 DAYS.

**Note:** The RMAN retention policy can be defined as part of a RMAN persistent configuration. The retention can be specified either by the number of backup versions to keep on the backup media (CONFIGURE RETENTION POLICY TO REDUNDANCY 2;) or by the number of days the backup versions should be kept (CONFIGURE RETENTION POLICY TO RECOVERY WINDOW OF 30 DAYS;).

### 6.3.7 Integration of BR\*Tools with Oracle RMAN

Optionally, you can configure Oracle RMAN as a backup agent sitting between BR\*Tools and the Tivoli Storage Manager server. In such a configuration, BR\*Tools calls RMAN to perform the backup and restore operations on the database. In this configuration, BR\*Tools is instructed to dynamically allocate the RMAN SBTAPI channel. The channel is then used to transfer data to and from the Tivoli Storage Manager server.

The integration of BR\*Tools and RMAN enables BR\*Tools to exploit the advantages of RMAN backup and restore functions, such as block checking during the backup and online backup, without needing to change the mode of data files (using the **alter tablespace begin backup** command).

This configuration also enables BR\*Tools for incremental backups, which are not supported when using the other BR\*Tools interfaces (BACKINT and dd). If you perform incremental backup, it can significantly reduce the requirements on the capacity of the backup storage media. Depending on the system environment,

this may also lead to a significant decrease in backup times. To implement such a configuration, you have to configure RMAN as a BR\*Tools backup interface.

the advantages of integrating RMAN with BR\*Tools are:

- ▶ Database blocks are checked for logical errors during the backup.
- ▶ Only the used database blocks are backed up.
- ▶ Tablespaces do not need to be set to BEGIN BACKUP mode, so the amount of logs generated during the backup is reduced.
- ▶ **BRBACKUP** integrated with RMAN supports cumulative incremental backup at level 1.

**Note:** For Oracle versions prior to 10g, usage of RMAN incremental backup may not reduce the duration of the backup process much, as the database has to check every database block being backed up for changes.

Oracle 10g implements a new feature called Block Change Tracking. Block Change Tracking solves this problem by tracking all the data blocks that have been changed. This results in faster incremental backup processing, because during the backup process Oracle only needs to read the changed blocks in data files.

You can enable Oracle block change tracking by issuing the following command:

```
ALTER DATABASE ENABLE  
BLOCK CHANGE TRACKING USING FILE '/oacle/admin/BCT/track.dbf';
```

The information about data block changes will be saved in the file `track.dbf`, as specified as a parameter of `alter database` command.

The Tivoli Storage Manager media management library (SBTAPI) is a part of Tivoli Storage Manager for ERP installation. In addition to Tivoli Storage Manager media management library for RMAN, Tivoli Storage Manager for ERP provides the BACKINT interface for Tivoli Storage Manager. In this configuration, BR\*Tools uses BACKINT to back up BR\*Tools profiles and logs. Database backup images are transferred to a Tivoli Storage Manager server by RMAN through the SBT channel.

**Tip:** The SAP integration of Oracle RMAN does not use a recovery catalog. Oracle uses a database control file as a repository to keep track of backups, so the Oracle parameter `control_file_record_keep_time` should be set to a value that is higher than the one for the RMAN retention policy.

A database backup consists of two steps:

1. BRBACKUP calls the backup function of Oracle RMAN. RMAN reads the database blocks to be backed up and sends it to the Tivoli Storage Manager media management library. The Tivoli Storage Manager media management library calls the Tivoli Storage Manager client API to send backup data to the Tivoli Storage Manager server.
2. After the database backup is completed, BRBACKUP sends the Oracle controlfile, BR\*Tools initialization profiles, and BR\*Tools log files to the Tivoli Storage Manager server using the BACKINT adapter. The control file sent in this step contains the information backup performed in step 1.

You can perform the following steps to configure BR\*Tools to use the RMAN Tivoli Storage Manager channel:

- ▶ On the Tivoli Storage Manager server:
  - a. Define a policy domain with two management classes that will be used to transfer data and logs. Define an archive management class within each of the management classes. If the retention control will be performed at the Tivoli Storage Manager server, specify RETVER=#of days for each archive copy group. If the retention control will be performed at Tivoli Storage Manager for ERP, specify RETVER=nolimit.
  - b. Register the Tivoli Storage Manager node with the defined domain. Update the parameter MAXNUMMP for the Tivoli Storage Manager node to MAXNUMMP=2 (based on the parallelism required).
- ▶ On the client node:
  - a. Update or create DSM.OPT and DSM.SYS to configure the Tivoli Storage Manager API client. The parameter PASSWORDACCESS must be set to "PROMPT" in this configuration.
  - b. Set up the environment values DSMI\_DIR and DSMI\_LOG for the Oracle OS user.
  - c. Install Tivoli Storage Manager for ERP (Oracle) on the Oracle server, with SAP already installed.
  - d. Configure the client resources for Oracle server in the Tivoli Storage Manager for ERP configuration file (<ORACLE\_HOME>\dbs\init<SID>.utl). Check the defined Tivoli Storage Manager node name and Tivoli Storage Manager management classes to be used for the backup of offline redo log files and data files. Make sure that the SERVER parameter refers to an existing stanza in the dsm.sys file. If the retention control will be driven by Tivoli Storage Manager for ERP, set the MAX\_VERSIONS parameter.

- e. Switch to the Oracle instance owner and update the Tivoli Storage Manager node password for Oracle using the following command:
- ```
backint -p <ORACLE_HOME>\dbs\init<SID>.utl -f password
```
- f. Make sure that RMAN can access the Tivoli Storage Manager SBTAPI. The following links must exist (be created):
- ```
ln -s /usr/tivoli/tsm/tdp_r3/ora/libtdp_r3.<ext>
/usr/lib/libobk.<ext> ln -s /usr/lib/libobk.<ext>
$ORACLE_HOME/lib/libobk.<ext>
```
- g. Instruct BR\*Tools to use RMAN by setting the `backup_dev_type` and `rman_parms` in the SAP initialization file (`init<SID>.sap`) as follows:
- ```
backup_dev_type = rman_util
rman_parms="ENV=(XINT_PROFILE=<ORACLE_HOME>/dbs/init<SID>.utl,PRO
LE_PORT=<portnumber>,&BR_INFO)"
```
- h. Instruct BR\*Tools to use the file `init<SID>.utl` for Tivoli Storage Manager specific parameters by setting the `util_par_file` parameter in the SAP initialization file:
- ```
util_par_file=<path to Tivoli Storage Manager for ERP util file -
init<SID>.utl>
```

## 6.3.8 References

For more information about the topics discussed in this section, refer to the following documents:

- ▶ *Oracle Database Backup and Recovery Basics*, B14192-03
- ▶ *Data Protection for SAP - Installation and User's Guide*, SC33-6340
- ▶ *Backing Up Oracle Using Tivoli Storage Management*, SG24-6249
- ▶ SAP White Paper *Oracle Database Administration - BR\*Tools with Oracle RMAN, 2008*, found at:

<https://www.sdn.sap.com/irj/sdn/go/portal/prtroot/docs/library/uuid/a8910c3a-0d01-0010-a6a9-f4a8aae140fe>



## 6.4 IBM DB2 UDB backup recovery tools

IBM DB2 UDB allows online or offline backups of the entire database or a set of tablespaces. DB2 also supports incremental backup and recovery (with the exception of large object data) of a database. Backup images can be placed into the local file system or local tape drive. You can also transmit the backup data to the Tivoli Storage Manager server or another media management system.

We discuss the following topics in this section:

- ▶ 6.4.1, “User interfaces” on page 157
- ▶ 6.4.2, “Backup control functions” on page 158
- ▶ 6.4.3, “Archived redo log backup functions” on page 160
- ▶ 6.4.4, “Restore and recovery functions” on page 162
- ▶ 6.4.5, “Media interfaces” on page 163
- ▶ 6.4.6, “Backup repository” on page 163
- ▶ 6.4.7, “DB2 UDB built-in Tivoli Storage Manager support” on page 164
- ▶ 6.4.8, “DB2 UDB with Tivoli Storage Manager for ERP (DB2)” on page 166
- ▶ 6.4.9, “References” on page 172

### 6.4.1 User interfaces

DB2 backup and restore functions can be accessed either from the DB2 Command-Line Interface (CLI) or from DB2 Control Center (shown in Figure 6-3 on page 158).

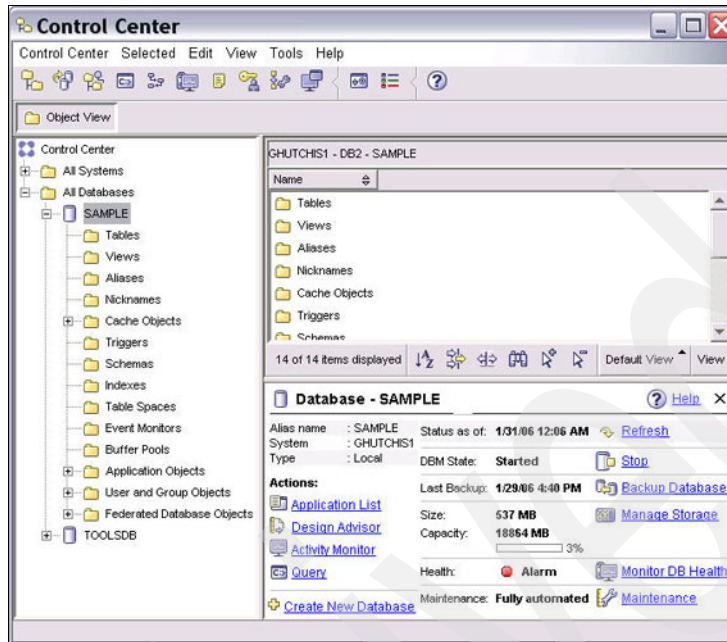

Figure 6-3 DB2 Control Center

## 6.4.2 Backup control functions

To be able to run backup and restore tasks on DB2, the user must have SYSADM, SYSCTRL, or SYSMAINT authority. Backup functions can be invoked from the DB2 CLI by using the **DB2 BACKUP** command. You can specify the type of backup and the backup storage media using the options of the **BACKUP** command. Here are the basic DB2 backup functions for performing backups on DB2 databases:

- ▶ Online backup

A full online backup creates a backup image of the entire database while the database is running and users are connected to the database. The following command uses the DB2 integrated Tivoli Storage Manager interface:

```
BACKUP DATABASE <SID> ONLINE USE TSM;
```

**Tip:** When performing an online backup on a DB2 database, you can specify that the log files generated during the backup operation are included in the backup image, as these logs are needed for recovery after restoration from online backup. This provides an additional protection against the deletion of the log files required for successful recovery. Use the `INCLUDE LOGS` parameter, as shown in this command:

```
BACKUP DATABASE <SID> ONLINE USE TSM INCLUDE LOGS;
```

► **Offline backup**

Before running an offline backup, all the database connections have to be closed. You have to stop the SAP system before starting the offline backup by running this command:

```
FORCE APPLICATION ALL;  
TERMINATE;  
BACKUP DATABASE <SID> USE TSM;
```

► **Partial (tablespace) backup**

A partial database backup performs a backup of the selected subset of DB2 tablespaces. The comma separated tablespace names must be specified after the `TABLESPACE` keyword as follows:

```
BACKUP DATABASE <SID> TABLESPACE <tablespace names> USE TSM;
```

► **Incremental backup**

An incremental backup captures all the changes that occurred on the database since the last full backup. This backup can be done by running this command:

```
BACKUP DATABASE <SID> ONLINE INCREMENTAL USE TSM;
```

A delta backup saves any data that has changed since the last backup of any type (full, incremental, or delta). This backup can be done by running this command:

```
BACKUP DATABASE <SID> ONLINE DELTA USE TSM;
```

**Note:** To run a tablespace level backup or online backup, DB2 must be configured in archive log mode instead of circular log mode. You can enable archive mode log by setting the LOGARCHMETH1 database configuration parameter. You must take a full backup after turning on the archive log mode.

To perform an incremental or delta backup, in addition to setting the enabled archive mode, you must set the database configuration parameter TRACKMOD to ON. This allows the database manager to keep track of database blocks modifications. The command to set TRACKMOD to ON is:

```
UPDATE DB CFG USING TRACKMOD ON;
```

### 6.4.3 Archived redo log backup functions

As well as database backups, you can move the archived log files stored on the local file system directly to the backup media. DB2 Log Manager, introduced in DB2 Version 8.2, replaced the user exit facility that was used in prior versions of DB2 to backup offline logs.

**Note:** For older DB2 versions, SAP provided its own log file management tool user exit for the administration of the DB2 transaction logs. With Version 8.2, DB2 UDB Log Manager allows fully integrated management and log file chaining. As of DB2 Version 9.1 for Linux, UNIX, and Windows or higher, the SAP log file management tools are no longer supported.

DB2 Log Manager is a component of the DB2 engine, and is responsible for automatic archiving and retrieving offline log files. Information about the physical location and time stamp of backed up redo log files is recorded in the DB2 recovery history file.

If the log manager is not able to transfer the archived log files to the backup media, you can instruct DB2 (by setting the database configuration parameter FAILARCHPATH) to place the log files temporarily into a local directory until the backup media (such as a Tivoli Storage Manager server) becomes available. This feature prevents the active log directory from filling up.

The backup destination for DB2 offline log files is set by the database configuration parameter LOGARCHMETH1.

DB2 Log Manager can transfer offline log files to two different backup destinations in parallel. You can enable the second backup location by setting up the database configuration parameter LOGARCHMETH2. The backup media (the values of the LOGARCHMETH1 and LOGARCHMETH2 parameters) that can be used by DB2 Log Manager are as follows:

- ▶ **DISK:<directory>**: Archived logs are placed into the local directory specified by the parameter <directory>. The command syntax is:

```
UPDATE DB CFG FOR <SID> USING LOGARCHMETH1 DISK:/BACKUPS
```

- ▶ **TSM:<management class>**: DB2 uses the Tivoli Storage Manager built-in support (plus Tivoli Storage Manager API client) to back up archived logs to the Tivoli Storage Manager server. The command syntax is:

```
UPDATE DB CFG FOR <SID> USING LOGARCHMETH1 TSM:SAP_LOGS_MGMT
```

- ▶ **VENDOR:<vendor library path>**: The media management API provided by the storage vendor is used to transfer backup data to the media management system. The command syntax is:

```
UPDATE DB CFG FOR <SID> USING LOGARCHMETH1  
VENDOR:/usr/tivoli/tsm/tdp_r3/db264/libtdpdb264.a
```

If you are configuring a vendor media library as a backup destination, the environment settings file for the vendor library must be defined to DB2 within the LOGARCHOPT1 parameter. The command syntax is:

```
UPDATE DB CFG FOR <SID> USING LOGARCHOPT1  
/db2/<SID>/tdp_r3/vendor.env
```

- ▶ **USEREXIT**: A user exit executable provided by a third party is called to back up archived logs.

**Note:** The former database configuration parameters USEREXIT and LOGRETAIN have been integrated into the LOGARCHMETH\* configuration parameters. During the migration to DB2 Version 8.2 (or when updating to DB2 Version 8.1 FP7, which corresponds to DB2 Version 8.2), LOGARCHMETH1 is set to USEREXIT if the database is using that parameter. The user exit method is not supported for DB2 Version 9.1 and higher.

## 6.4.4 Restore and recovery functions

This section only covers the basic restore and roll-forward options provided by the DB2 database. For detailed information about DB2 restore and recovery, refer to the DB2 UDB documentation. DB2 UDB supports the following basic restore and roll-forward functions:

- ▶ Full database restore

To perform an offline restore of a database from the latest full backup image using the Tivoli Storage Manager built-in support, run this command:

```
restore database <SID> use TSM
```

To perform an offline restore of a database from a full backup taken on February 22 2008 at 16:10: 30 using the Tivoli Storage Manager built-in support, run this command:

```
restore database <SID> taken at 20080222161030 use tsm;
```

- ▶ Partial database restore

To perform an online restore of the tablespaces syscatspace and userspace1 from the last backup, run this command:

```
restore database <SID> tablespace (syscatspace1,userspace1) online  
use TSM;
```

- ▶ Database roll-forward recovery

For roll-forward recovery, the LOGARCHMETH1 must be the same as the time when the backup is taken. To perform an offline rollforward on an entire database to the end of the logs (complete full recovery), run this command:

```
rollforward database <SID> to end of logs and complete;
```

To perform an offline rollforward on an entire database to a point in time (incomplete full recovery), run this command:

```
rollforward database <SID> to 2008-03-10-15.50.21.253422
```

To perform an online rollforward on a tablespace userspace1 to end of logs (complete tablespace recovery):

```
rollforward datatabase <SID> to end of logs and stop tablespace  
(userspace1)
```

## 6.4.5 Media interfaces

The backup media for database backup is specified by a parameter for the DB2 BACKUP command. Backups performed by DB2 can be transferred to the following destinations:

- ▶ Directory or device: A backup is saved directly to the specified local directory or device (such as a tape drive). The command syntax is:

```
BACKUP DB <SID> TO <DIRECTORY>
```

- ▶ Tivoli Storage Manager: DB2 calls the Tivoli Storage Manager API to transfer backup data to the Tivoli Storage Manager server. The command syntax is:

```
BACKUP DB <SID> USE TSM
```

- ▶ XBSA: Specifies that the XBSA interface should be used as an interface to the backup system. X/Open Backup Services APIs (XBSA) are open application programming interfaces for applications or facilities needing data storage management for backup or archiving purposes. The command syntax is:

```
BACKUP DB <SID> USE XBSA <XBSA OPTIONS>
```

- ▶ Backup vendor library: Backup is transferred using the shared library (or DLL on Windows) specified by the LOAD parameter of the DB2 backup command. The command syntax is:

```
BACKUP DB <SID> LOAD /usr/tivoli/tsm/tdp_r3/db264/libtdpdb264.a
```

The example loads the Tivoli Storage Manager for ERP backup object manager (backom) to back up the Tivoli Storage Manager server.

## 6.4.6 Backup repository

The information about the location and time stamp of backups is recorded in the DB2 recovery history file. DB2 uses the recovery history file to, for example, determine the version of a backup image and log files to be restored according to the time stamp specified in the point-in-time restore. The DB2 recovery history file is also queried whenever the user issues the **list history** command, which prints the summary of backup operations performed on the database.

**Note:** The information about backups displayed in the Database Backup tab in SAP DBA Cockpit is taken from the DB2 recovery history file. Therefore, the Database Backup tab shows the backups executed by DB2 CLI or by Backup Object Manager.

The basic commands that are used to manage DB2 recovery history information are as follows:

- ▶ **LIST HISTORY:** Used to list the records of backup/recovery and administrative events in the history file. The command syntax is:  

```
LIST HISTORY BACKUP ALL FOR DB <SID>  
LIST HISTORY ARCHIVE LOG ALL FOR DB <SID>
```
- ▶ **UPDATE HISTORY:** Used to update the location, device type, comment, or status in the DB2 history record. The command can be used when, for example, backups have been moved to a different location or if the backup images are no longer available.
- ▶ **PRUNE HISTORY:** Used to delete entries from the recovery history file.

### 6.4.7 DB2 UDB built-in Tivoli Storage Manager support

This section discusses the DB2 UDB built-in Tivoli Storage Manager support. The following topics are discussed:

- ▶ “Configuration” on page 164
- ▶ “Backup retention control” on page 165

#### Configuration

The configuration of the DB2 backup interface is performed partly in the DB2 database configuration and partly in the the operating system. You can perform the following steps to set up DB2 UDB to use the Tivoli Storage Manager API interface:

- ▶ On the Tivoli Storage Manager server:
  - a. Define a policy domain with one management class that will be used to transfer data and logs. Define a backup copy group and archive copy group within the management class. Assign the defined management class as a default management class for the defined policy domain. For the backup copy group, specify the retention parameters as VEREX=1, VERDEL=0, RETEXT=0, RETONLY=0. For the archive management class, specify RETVER=NOLIMIT.
  - b. Register the Tivoli Storage Manager node with the defined domain. Update the parameters for Tivoli Storage Manager node as BACKDEL=Yes, MAXNUMMP=2 (depending on the required parallelism level)



- ▶ On the client node:
  - a. Update or create `dsm.opt` and `dsm.sys` to configure the Tivoli Storage Manager API client for DB2. The parameter `PASSWORDACCESS=GENERATE` must be set for this configuration.
  - b. Set up the environment values `DSMI_DIR`, `DSMI_CONFIG`, and `DSMI_LOG` for the DB2 owner user. `DSMI_CONFIG` should point to the `dsm.opt` file, which contains the name of the server stanza, from `dsm.sys` file, to be used.
  - c. Update the Tivoli Storage Manager client password file for DB2 node using the executable `<DB2_HOME>\sql11ib\adsm\dsmapiw`. You need to switch to root before updating the password using `dsmapiw`. Before updating the password, you might need to export the variables `DSMI_DIR`, `DSMI_CONFIG`, and `DSMI_LOG` so that they can be used by the root user.
  - d. Restart the DB2 instance.
  - e. Optionally, you can enable DB2 automatic log management so that it sends archived logs to Tivoli Storage Manager using the built-in support. This can be specified by setting the DB2 configuration parameter `LOGARCHMETH1` as follows:
 

```
update db cfg for <SID> using LOGARCHMETH1 TSM:<management_class>
```
  - f. If you use the direct log backup method specified in step e, you should also specify DB2 configuration parameter `FAILARCHPATH`. `FAILARCHPATH` points to the directory to be used as a temporary storage for offline logs in case that the Tivoli Storage Manager server is unavailable. This can prevent the DB2 from filling up the log directory. The command syntax is:
 

```
update db cfg for <SID> using FAILARCHPATH <offline_log_path>
```

## Backup retention control

You can use the `DB2ADUTL` utility to manage the backup images transferred using DB2 Tivoli Storage Manager built-in facility (using the `BACKUP DATABASE USE TSM` command). `DB2ADUTL` is the command line executable installed as a part of DB2 UDB. The following are the basic functions used to control backups:

- ▶ **DELETE:** Used to remove selected database backups or backed up redo logs from the Tivoli Storage Manager server. This parameter is frequently used in backup scripts to control the number of backup versions kept on the Tivoli Storage Manager server. The backup retention can be specified either by the number of backup versions to be kept or by the number of days.

To delete versions of backup images specified by the number of images to be kept:

```
DB2ADUTL DELETE FULL KEEP <# OF BACKUP IMAGES> DB <SID> WITHOUT PROMPTING;
```

To delete the versions of backup images specified by the number of days:

```
DB2ADUTL DELETE FULL OLDER THAN <# OF DAYS> DB <SID> WITHOUT PROMPTING;
```

To delete the set of offline logs specified by the name of the first and last log file:

```
DB2ADUTL DELETE LOGS BETWEEN S0000000.LOG AND <NAME OF THE LAST LOG TO DELETE>
```

- ▶ **QUERY:** Used to display the backup objects (backup images, redo log backups, or both) stored on the Tivoli Storage Manager server. The command syntax is:  

```
DB2ADUTL QUERY FULL  
DB2ADUTL QUERY LOGS
```
- ▶ **EXTRACT:** Copies DB2 objects from the Tivoli Storage Manager server to the current directory on the local machine.
- ▶ **GRANT:** Adds the access rights to the Tivoli Storage Manager files on the current Tivoli Storage Manager node to all users or to the users specified. Granting access to users gives them access for all current and future files related to the database specified.
- ▶ **REVOKE:** Removes access rights to the Tivoli Storage Manager files on the current Tivoli Storage Manager node from all users or to the users specified.
- ▶ **QUERYACCESS:** Retrieves the current access list. A list of users and Tivoli Storage Manager nodes is displayed.

**Note:** To enable DB2ADUTL to delete obsolete backups, the parameter BACKDEL=YES must be set for the Tivoli Storage Manager node. This parameter grants the Tivoli Storage Manager client the right to delete stored backup objects.

## 6.4.8 DB2 UDB with Tivoli Storage Manager for ERP (DB2)

Tivoli Storage Manager for ERP (DB2) is a software package developed by IBM. In addition to backup and restore functions, Tivoli Storage Manager for ERP provides functionality designed especially for the SAP environment. Tivoli Storage Manager for ERP (DB2) provides the Tivoli Storage Manager adapter for DB2. DB2 can interact with Tivoli Storage Manager for ERP (DB2) through the

vendor library interface. The interaction of DB2 and Tivoli Storage Manager for ERP proceeds as follows:

1. The DB2 Command-Line Processor interprets backup and restore commands and passes control to a DB2 Server Process.
2. The DB2 Server Process dynamically loads the Tivoli Storage Manager for ERP shared library, reads the data from the database containers, reads the DB2 configuration files, and passes the backup data to the DB2 vendor library.
3. The Tivoli Storage Manager shared library transfers the data to the Tivoli Storage Manager server using the Tivoli Storage Manager client API.

Figure 6-4 gives an overview of these steps.

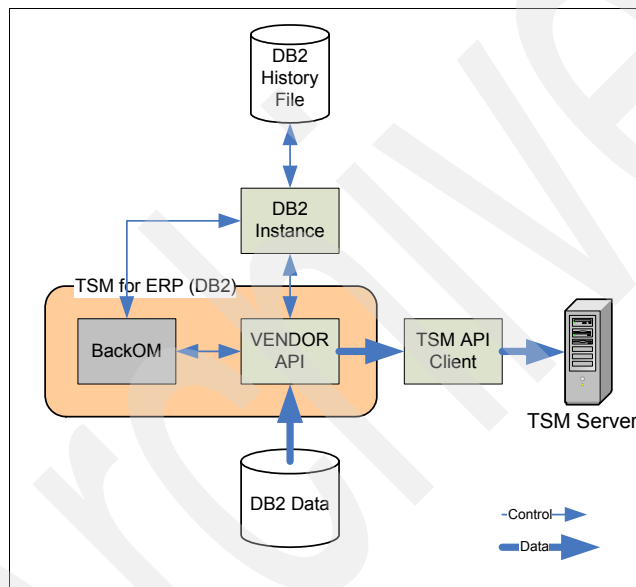

Figure 6-4 Tivoli Storage Manager for ERP communication

Tivoli Storage Manager for ERP (DB2) keeps information about all tablespaces of a database backed up for every backup image on Tivoli Storage Manager. This information about the physical database layout, the Tablespace Definition Information (TDI), is stored in addition to the production data. The TDI is a prerequisite for redirected restore.

The Backup Object Manager (backom) provides redirected restore functionality based on the redirected restore facility of DB2. With redirected restore, an administrator can:

- ▶ Restore a DB2 database to a different location.
- ▶ Change the physical database layout of a restored database, including the location of tablespace containers, the number of tablespace containers, their names, and their sizes.
- ▶ Clone a database, changing both the name and the location of the database.

With Backup Object Manager, a redirected restore of a database can be performed nearly automatically using a simple set of commands. BackOM also performs some plausibility checks before actually starting the operation.

## Configuration

You can perform the following steps to configure DB2 to use Tivoli Storage Manager for ERP:

- ▶ On the Tivoli Storage Manager server:
  - a. Define a policy domain with two management classes that will be used to transfer data and logs. Define an archive copy group for both management classes. If the retention control will be performed at the Tivoli Storage Manager server, specify `RETVER=<days>` for each archive copy group. If the retention control will be performed at Tivoli Storage Manager for ERP level, specify `RETVER=nolimit`.
  - b. Register TSM node with the defined domain. Update the parameter `MAXNUMMP` for TSM node to `MAXNUMMP=2` (based on the parallelism required).
- ▶ On the client node:
  - a. Update or create Tivoli Storage Manager API client option files `DSM.0PT` and `DSM.SYS`. The parameter `PASSWORDACCESS=GENERATE` must be set for this configuration.
  - b. Configure the environment values `DSMI_DIR`, `DSMI_CONFIG`, and `DSMI_LOG` in the DB2 instance owner user's profile. You need to restart the DB2 instance to make the parameters effective for DB2.
  - c. Install Tivoli Storage Manager for ERP (DB2) on the DB2 UDB server, with SAP already installed. The installation wizard lets you specify the name of Tivoli Storage Manager server stanza (in `dsm.sys`), the Tivoli Storage Manager node name, and the management classes to be used for the backup of data and archived logs.

- d. Check the client resource for the Tivoli Storage Manager server in the Tivoli Storage Manager for ERP configuration file `/db2/<SID>/tdp_r3/init<SID>.ut1`. Verify that the following environment variables are set correctly in the DB2 owner user's profile:

```
XINT_PROFILE, DB2_VENDOR_LIB, TDP_DIR
```

- e. Switch to the DB2 instance owner and update the Tivoli Storage Manager client password for DB2 node using the following command:

```
$/usr/tivoli/tsm/tdp_r3/db264/backom -c password
```

- f. Restart the DB2 instance.

- g. Optionally, you can set up DB2 automatic log management so that the archived logs are sent to Tivoli Storage Manager using the Tivoli Storage Manager media management library provided by Tivoli Storage Manager for ERP. This can be achieved by setting the DB2 configuration parameters `LOGARCHMETH1` and `LOGARCHOPT1` as follows:

```
update db cfg for <SID> using LOGARCHMETH1
VENDOR:/usr/tivoli/tsm/tdp_r3/db264/libtdpdb264.a
update db cfg for <SID> using LOGARCHOPT1
/db2/<SID>/tdp_r3/vendor.env
```

- h. If you use the direct log backup method specified in step g, you should also specify db2 configuration parameter `FAILARCHPATH`. `FAILARCHPATH` points to a directory to be used as a temporary storage for offline logs in case that the Tivoli Storage Manager server is unavailable. This can prevent the DB2 from filling up the log directory. The command syntax is:

```
update db cfg for <SID> using FAILARCHPATH <offline log path>
```

## Backup control functions

You can call the backup and restore functions of Tivoli Storage Manager for ERP (DB2) either from the DB2 CLI or by using the Tivoli Storage Manager for ERP Backup Object Manager (`backom`). Backup Object Manager is the utility provided with Tivoli Storage Manager for ERP (DB2) for backing up databases and querying, restoring, and deleting backup objects residing on the Tivoli Storage Manager server (including database backup images and logs backed up in Tivoli Storage Manager).

The functions are:

- ▶ DB2 online backup with Tivoli Storage Manager for ERP

The following command executes DB2 online backup using Backup Object Manager (**backom**):

```
backom -c b_db -a <SID> -0
```

You can also run an online backup by calling the Tivoli Storage Manager API library directly on the DB2 CLI:

```
BACKUP DB <SID> ONLINE LOAD  
/usr/tivoli/tsm/tdp_r3/db264/libtdpdb264.a
```

- ▶ DB2 offline backup with Tivoli Storage Manager for ERP:

```
backom -c b_db -a <SID>
```

- ▶ DB2 tablespace backup with Tivoli Storage Manager for ERP:

```
backom -c b_db -a <SID> -T <comma separated tablespace names>
```

- ▶ DB2 incremental backup with Tivoli Storage Manager for ERP

You can instruct Backup Object Manager to make an incremental backup by specifying the option R followed by the type of backup. You can specify one of the following three backup types:

- Full
- Incremental
- Delta

The following example illustrates the online incremental backup using Backup Object Manager:

```
backom -c b_db -a <SID> -0 -R incremental
```

You can also make an incremental backup by calling the backup function on the DB2 CLI as follows:

```
BACKUP DB <SID> ONLINE INCREMENTAL LOAD  
/usr/tivoli/tsm/tdp_r3/db264/libtdpdb264.a
```

## Restore and recovery functions

As well as backup, you can call the restore and recovery functions either using Backup Object Manager or directly on the DB2 CLI or DB2 GUI. The restore and recovery functions are the same as though you run a backup using built-in Tivoli Storage Manager support.

The functions are:

- ▶ Full database restore

To perform an offline restore of a database from the latest full backup using Backup Object Manager (**backom**), run this command:

```
db2sid>backom -c r_db -a <SID>
```

You can also run the restore of a database directly from DB2 CLI as follows:

```
DB2>restore database <SID> LOAD  
/usr/tivoli/tsm/tdp_r3/db264/libtdpdb264.a
```

To restore perform an offline restore of a database from the full backup taken on February 22 2008 at 16:10: 30 using using Backup Object Manager (**backom**), run this command:

```
db2sid>backom -c r_db -a <SID> -t 20080222161030
```

► Partial database restore

To perform an online restore of the tablespaces syscatspace and userspace1 from the last backup, run this command:

```
DB2>restore database <SID> tablespace (syscatspace1,userspace1)  
online LOAD /usr/tivoli/tsm/tdp_r3/db264/libtdpdb264.a;
```

► Database roll-forward recovery

**Note:** In order to perform the roll-forward operation, DB2 needs access to the backed up offline logs. Make sure that the DB2 configuration parameters LOGARCHMETH1 and LOGARCHOPT1 have the same values that they had during the time the backup of the logs was taken. If the log files are to be restored using the Tivoli Storage Manager vendor library provided by Tivoli Storage Manager for ERP, the correct settings are as follows:

```
LOGARCHMETH1=VENDOR:/usr/tivoli/tsm/tdp_r3/db264/libtdpdb264.a  
LOGARCHOPT1=/db2/<SID>/tdp_r3/vendor.env
```

To perform an offline rollforward on an entire database to end of logs (complete full recovery), run this command:

```
DB2>rollforward database <SID> to end of logs and complete;
```

To perform an offline rollforward on an entire database to a point in time (incomplete full recovery), run this command:

```
DB2>rollforward database <SID> to 2008-03-10-15.50.21.253422
```

To perform an online rollforward on a tablespace userspace1 to end of logs (complete tablespace recovery), run this command:

```
DB2>rollforward datatabase <SID> to end of logs and stop tablespace  
(userspace1)
```

## Backup retention control

► DB2 List Database Backups (Tivoli Storage Manager for ERP)

To list all the backup images for the <SID> database, run this command:

```
db2sid>backom -c q_db -a <SID>
```

- ▶ **DB2 List DB2 Logfile Backups (Tivoli Storage Manager for ERP)**  
To list all the backups of archived logs for <SID> database, run this command:  

```
db2sid>backom -c q_log -a <SID>
```
- ▶ **DB2 Delete Database Backups (Tivoli Storage Manager for ERP)**  
To delete all DB2 backup images that were created before June 2002, run this command:  

```
db2sid>backom -c d_db -a <SID> -t 1900*-20020601000000
```
- ▶ **DB2 Delete Backup of Archived Logs (Tivoli Storage Manager for ERP)**  
To delete all DB2 log files that were created before June 2002, run this command:  

```
db2sid>backom -c d_log -a <SID> -t 1900*-20020601000000
```

### 6.4.9 References

The following are some additional references that you can use for more information about the topics discussed in this section:

- ▶ *IBM Tivoli Storage Management Concepts, SG24-4877*
- ▶ *IBM Tivoli Storage Management Concepts, SG24-4877*
- ▶ *Backing Up DB2 Using IBM Tivoli Storage Management, SG24-6247*

## 6.5 SAP MaxDB backup recovery tools

SAP MaxDB is a cost-effective database developed by SAP AG to provide an alternative database system to other vendor's databases, such as Oracle or IBM DB2. MaxDB is deployed in SAP environments for various applications, such as SAP ERP, the LiveCache in APO application, or the Repository for KnowledgeProvider.

MaxDB has a standard transactions-based RDBMS architecture. The application data and database catalog are stored in a data area that consists of the data volumes. The volumes can either be files, parts of the disk, or complete physical disks. All the change operations to the data are recorded in a log area made up of log volumes.

The MaxDB data is stored in the database data area. In case of a logical or physical error in the data area, you have to restore the data from an intact backup image stored on the media. To restore the database to a point in time



preceding the failure, you also have to restore the log area. Thus, to ensure the appropriate data protection, you should back up the data and log areas regularly.

MaxDB supports the backup and restore functionality for both data and log areas. Every backup is made to a backup media represented by the corresponding media definition in the MaxDB configuration.

In addition to the disk backup, MaxDB supports interfaces to external media management systems, such as Tivoli Storage Manager. MaxDB backups can be transferred to a Tivoli Storage Manager server through ADINT/TSM, an IBM service offering especially developed for MaxDB to provide seamless connection to Tivoli Storage Manager with direct (no intermediate storage) data transfer..

This section includes the following topics:

- ▶ 6.5.1, “User interfaces” on page 173
- ▶ 6.5.2, “Backup control functions” on page 174\
- ▶ 6.5.3, “Archived redo log backup functions” on page 175
- ▶ 6.5.4, “Restore and recovery functions” on page 175
- ▶ 6.5.5, “Media interfaces” on page 177
- ▶ 6.5.6, “Backup repository” on page 178
- ▶ 6.5.7, “MaxDB with ADINT/TSM” on page 178
- ▶ 6.5.8, “References” on page 181

## 6.5.1 User interfaces

MaxDB backup and restore commands can be invoked from the Database Studio, Database Manager CLI ,or CCMS (for an SAP environment). The database manager for MaxDB DBMGUI is shown in Figure 6-5 on page 174.

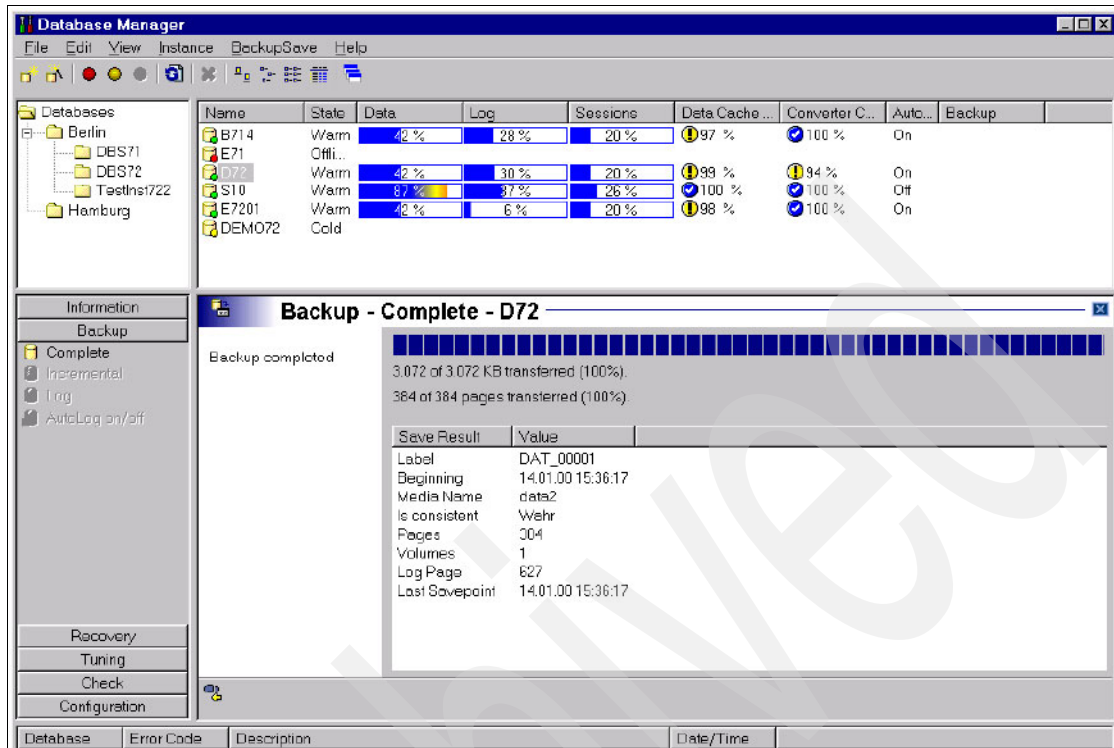

Figure 6-5 MaxDB DBMGUI: Database Manager

## 6.5.2 Backup control functions

MaxDB provides functions for a complete data backup and incremental data backup (it saves only the data that has changed since the last complete backup) and backup of the log area.

A backup can be triggered by the DBMCLI command **backup\_start**. For each database backup, you have to specify the type of backup (full, incremental, or log) and the media to be used to store the backup image:

- ▶ A full database backup saves all the blocks of the database that have already been used:

```
backup_start <medium_name> recovery DATA
```

You can also run a backup from the OS's command line and specify the backup parameters as options of the **dbmcli** executable:

```
/sapdb/programs/bin/dbmcli -uUTL -d <SID> -u <username>,<password>  
backup_start <medium_name> recovery DATA
```

An example for a backup using full backup is:

```
$su - sdb -c "/sapdb/programs/bin/dbmcli -uUTL -d CST -u  
gcbckusr,passwd backup_start BACK_full recovery DATA"
```

- ▶ Incremental backup saves the blocks that have changed since the last full backup. The command syntax is:

```
dbmcli -d <database_name> -u <user_name>,<password> -uUTL -c  
backup_start incrF
```

### 6.5.3 Archived redo log backup functions

The redo log records are stored in the log area of the database system. The backup of log data is needed for instance recovery in case of a media failure. Another reason to perform backups of the log records is that the database can overwrite only the log segments that have already been backed up (unless the overwrite mode is not activated). If the log area is filled up with unsaved entries, the database halts, as it is not able to insert the new log entries.

The log backup function copies all the log entries that have been recorded to the log area since the last log backup. It can save the log backups to the media defined in the database configuration. A backup of the log area can be performed from DBMCLI by running the following command:

```
dbmcli backup_start <medium_name> <backup_type> LOG
```

A sample full command is:

```
su - sdb -c "/sapdb/programs/bin/dbmcli -uUTL -d CST -u  
gcbckusr,passwd backup_start BACK_log LOG"
```

### 6.5.4 Restore and recovery functions

You can trigger restore and recovery functions of a database from the MaxDB CLI or GUI interface. To restore the backup image, the media definition used for the backup transfer has to be present in the MaxDB configuration. You can perform a full restore of the data area and log area as follows:

1. Switch the MaxDB database into admin mode by running this command:

```
dbmcli -d <SID> -u <username>,<password> db_admin
```

2. Open the DBM CLI interface by running this command:

```
dbmcli -d <SID> -u <username>,<password> -uUTL
```

3. Query the external backup tool for existing backup IDs. You have to query both DATA and LOG media types. Run the following command:

```
dbmcli -d <SID> backup_ext_ids_get <External Media ID>
```

4. List the backup IDs fetched in the previous step by running the following command:

```
dbmcli -d <SID> backup_ext_ids_list
```

Example 6-13 shows a sample listing of external IDs.

*Example 6-13 External IDs listed by backup\_ext\_ids\_list function*

---

AVAILABLE	desmoines01_CSX_2008.05.22_00.45.06_SAVEDTNCHK_ADSM_DATA	DATA
RECOVERY	2008-05-22 00:45:06	
AVAILABLE	desmoines01_CSX_2008.06.08_20.09.13_SAVEDTNCHK_ADSM_data	DATA
RECOVERY	2008-06-08 20:09:13	
AVAILABLE	desmoines01_CSX_2008.06.08_20.43.43_SAVEDTNCHK_ADSM_data	DATA
RECOVERY	2008-06-08 20:43:43	
AVAILABLE	desmoines01_CSX_2008.06.08_20.50.07_SAVEDTNCHK_ADSM_data	DATA
RECOVERY	2008-06-08 20:50:07	
AVAILABLE	desmoines01_CSX_2008.06.08_20.50.58_SAVELOG_ADSM_log	LOG
RECOVERY	2008-06-08 20:50:58	
AVAILABLE	desmoines01_CSX_2008.06.08_21.56.18_SAVEDTNCHK_ADSM_data	DATA
RECOVERY	2008-06-08 21:56:18	
AVAILABLE	<b>desmoines01_CSX_2008.06.10_10.30.40_SAVEDTNCHK_ADSM_data</b>	DATA
RECOVERY	2008-06-10 10:30:40	
AVAILABLE	<b>desmoines01_CSX_2008.06.10_10.31.56_SAVELOG_ADSM_log</b>	LOG
RECOVERY	2008-06-10 10:31:56	

---

5. Restore the data area from the latest backup image. Specify the external backup ID of the latest backup of type DATA similar to the one shown in Example 6-13. The command syntax is:

```
dbmcli -d <SID> recover_start <Backup Media ID> <backup type> EBID  
<Backup ID>
```

6. Restore the log area. In the restore command, specify the latest external backup ID of type LOG. The time stamp of the Log backup must be newer than the time stamp of the DATA backup, and this time stamp can be collected again from Example 6-13. The command syntax is:

```
dbmcli -d <SID> recover_start ADSM_log LOG EBID  
desmoines01_CSX_2008.06.10_10.31.56_SAVELOG_ADSM_log
```

7. Switch the restored MaxDB database to online mode by running this command:

```
dbmcli -d <SID> db_online
```

## 6.5.5 Media interfaces

Every MaxDB backup performed on the database must be assigned a backup medium. A backup medium is an user defined object in the MaxDB configuration that represents either a disk file, tape, or pipe. The parameters specified for the media definition correspond with the features of the target backup device (such as tape capacity).

For every backup media definition, you have to specify the following parameters:

- ▶ ID of backup media: Uniquely identifies the media definition. The backup media is referenced by its ID in the backup and restore commands.

**Note:** In MaxDB Version 7.5. and later, the name of the media has to correspond with the type of external backup tool used. The media name must begin with the following strings:

- ▶ For IBM Tivoli Storage Manager media: ADISM<name of the media>
  - ▶ For BACKINT (for Oracle, for SAP DB): BACK<name of the media>
  - ▶ For Legato Networker: NSR<name of the media>
- 
- ▶ Backup type: Specifies the backup operations that will be performed using the medium:
    - Complete data backup (DATA)
    - Incremental data backup (PAGES)
    - Log backup (LOG)
  - ▶ Device type: specifies the data carrier type. You can set the following values:
    - File (FILE): The device type can be used for all backup types.
    - Tape (TAPE): The device type can be used for data backup only.
    - Pipe (PIPE): The device type can be used for data backup and log backup. This device type does not support automatic log backup.
  - ▶ Type of the Media Management System (MMS): If an external MMS is used, you have to specify the type of the system. MaxDB supports the following MMSs:
    - IBM Tivoli Storage Manager
    - Legato Networker (NSR)

**Note:** ADINT/TSM uses the SAP MaxDB pipe interface. Therefore, the media type has to be defined as PIPE.

- ▶ Device or file of data carrier: The name of the OS device or path and name of file or pipe. Example 6-14 shows the definition.

*Example 6-14 MaxDB media definition*

---

```
dbmcli>medium_put BACK_full /tmp/data.pipe1 PIPE DATA 0 8 NO NO \"\">  
\" TSM
```

---

## 6.5.6 Backup repository

The information about all the performed backup and restore transactions are recorded in the MaxDB backup history (in the `dbm.kn1` file). Every backup that is transferred to the medium through an external backup tool is assigned an external backup ID. The ID is either provided by MaxDB instance or by the external media management tool. MaxDB records the external backup IDs in the backup history (`dbm.kn1`) and `dbm.ebf`. The external backup ID is used to specify the backup image to be restored.

The basic functions associated with the backup history are as follows:

- ▶ To display the content of the backup history, run this command:  

```
dbmcli>backup_history_list
```
- ▶ To fetch the information about backups saved in the external backup system (ext.IDs, the availability status, the backup time, and creation time), run this command:  

```
dbmcli>backup_ext_ids_get <medium_name> <database_name> <server>
```
- ▶ To list the information fetched from the external backup system, run this command:  

```
dbmcli>backup_ext_ids_list
```

## 6.5.7 MaxDB with ADINT/TSM

IBM ADINT/TSM is a software package that provides the Tivoli Storage Manager backup adapter for MaxDB. The backup data is transferred from MaxDB to the ADINT interface through the named pipes. The ADINT agent then calls the Tivoli Storage Manager Client API, which reads the data from the pipes and transfers it to the Tivoli Storage Manager server.

ADINT/TSM supports the MaxDB backup and restore operations as follows:

- ▶ Full online and offline backup and restore
- ▶ Log backup and restore
- ▶ Incremental backup and restore

In addition to backup and restore tasks, ADINT can serve as a tool for database cloning. The database clone can be created by restoring data from one MaxDB instance to another instance. You can also configure ADINT to serve as an interface for data archiving using the ArchiveLink (CommonStore).

IBM ADINT/TSM supports backup enhancement techniques such as LAN-free backup. Database backup transfers can be optimized by using multithreaded transfers within one session or multiple parallel backup sessions.

**Note:** ADINT/TSM uses the archive functions of the Tivoli Storage Manager API Client to transfer data to and from Tivoli Storage Manager server. Therefore, the management classes assigned to ADINT backup must have an archive copy group defined.

## Configuration

You can perform the following steps to configure SAP MaxDB to use ADINT/TSM:

- ▶ On the Tivoli Storage Manager server:
  - a. Define a policy domain with two management classes that will be used to transfer data and logs. Define the archive copy group for both management classes. If the backup retention will be controlled by ADINT, specify the parameter `RETVER=nolimit` for both of the archive copy groups. If the expiration of backups will be controlled by the Tivoli Storage Manager server, specify `RETVER= "# of versions to keep"` for both of the archive copy groups.
  - b. Register a Tivoli Storage Manager node with the domain defined in the previous step.

- ▶ On the client node:
  - a. Update or create the Tivoli Storage Manager API client option files DSM.OPT and DSM.SYS. The parameter PASSWORDACCESS must be set to "GENERATE" for this configuration.
  - b. Configure the following environment values (DSMI\_DIR and DSMI\_LOG) in the MaxDB user's profile.
  - c. Install ADINT/TSM into the MaxDB server. The installation wizard lets you specify the name of Tivoli Storage Manager server stanza (in dsm.sys), the Tivoli Storage Manager node name, and management classes for data and logs.
  - d. Switch to the MaxDB instance owner and update the Tivoli Storage Manager node password for MaxDB using the following command:
 

```
sdb$adint2 -x
```
  - e. Register ADINT/TSM in the MaxDB environment by setting the variables ADINT and ADA\_OPT as follows:
 

```
sdb$dbmcli -d <SID> -u <username>,<password> -uUTL
dbmcli>dbm_configset -raw ADINT /usr/tivoli/tsm/adint64
dbmcli>dbm_configset -raw ADINT_UTL /sapdb/adint/init<SID>.utl
```
  - f. Define the MaxDB media for ADINT/TSM with the following parameters:
    - Backup name: The media name must start with ADSM (MaxDB up to V7.5).
    - Backup type: DATA or LOG, depending on the purpose of the media.
    - Device type: PIPE.
    - Type of media management system: TSM (MaxDB V7.6 and higher only).

If you are using MaxDB V7.5 or earlier, you can define the media as follows:

```
dbmcli -d <SID> -u <username>,<password> -uUTL
dbmcli>medium_put ADSM_full /tmp/data.pipe1 PIPE DATA
dbmcli>medium_put ADMS_log /tmp/log.pipe1 PIPE LOG
```

If you are using MaxDB V7.6 and later, specify the media definition as follows:

```
dbmcli -d <SID> -u <username>,<password> -uUTL
dbmcli>medium_put BACK_full /tmp/data.pipe1 PIPE DATA 0 8 NO NO
\"\" \"\" TSM
dbmcli>medium_put BACK_log /tmp/log.pipe1 PIPE DATA 0 8 NO NO
\"\" \"\" TSM
```



## Backup retention control

The backup retention policy can be configured either on the Tivoli Storage Manager server using the archive copy group parameter `RETVER` (the number of days the backup version is to be kept) or on the ADINT/TSM by specifying the parameter `MAX_VERSIONS` in the configuration profile (`init<SID>.utl`).

The parameter `MAX_VERSIONS` defines the maximum number of database backup versions to be kept in backup storage. The default setting for this value is 0, meaning that backup version control is disabled.

If you use ADINT/TSM backup retention control, set the TSM copy group parameter `RETVER` to `RETVER=nolimit` to disable the expiration of backup versions by Tivoli Storage Manager server policies. If you use the versioning based on the Tivoli Storage Manager server expiration (`RETVER`), set `MAX_VERSIONS=0` to disable the versioning at the ADINT/TSM level.

## 6.5.8 References

You can use the following links and books as further references about the topics discussed in this section:

- ▶ *IBM ADINT/Tivoli Storage Manager for MaxDB - Installation and User's Guide, 2005*, found at:  
[http://www-05.ibm.com/de/entwicklung/adint\\_tsm/download/user\\_guide.pdf](http://www-05.ibm.com/de/entwicklung/adint_tsm/download/user_guide.pdf)
- ▶ *SAP, MaxDB - The Professional DBMS, 2005*, found at:  
<http://mysql2.mirrors-r-us.net/doc/maxdb/pdf/whitepaper.pdf>

## 6.6 Summary of backup tools

Table 6-2 lists a summary of Tivoli Storage Manager backup adapters for databases.

Table 6-2 Summary of Tivoli Storage Manager backup adapters for databases

Backup Manager	Oracle RMAN	BR*Tools	DB2 UDB (TSM Built-in Suppt)	DB2 UDB (TSM for ERP)	SAP MaxDB
Backup command	backup database ...	BRBACKUP ...	backup db <sid> use tsm	backom -c b_db or DB2>backup db <sid> load <tsm api library>	DBMCLI>back up_start data
Backup of redo logs	backup archivelog ...	u	UPDATE DB CFG: LOGARCHME TH1=TSM	UPDATE DB2 DB CFG: LOGARCHME TH1=VENDOR:<tsm api library> LOGARCHOPT1=< api opt file>	DBMCLI>back up_start log
Restore Command	restore ...	brrestore	restore db	backom -c r_db	DBMCLI>reco ver_start data
Complete or incomplete (PIT) recovery command	recover ...	brrecover	rollforward db	backom -c r_log; DB2>rollforwa rd db	DBMCLI>reco ver_start log
List backup command	list ..., report ...	brtools interface	db2adutlquery ...	backom -c q_db, backom -c q_log	DBMCLI>back up_ext_ids_ge t; DBMCLI>back up_ext_ids list
Backup retention control	delete ...	by TSM Server: RETVER or by TSM for ERP: MAX_VERSIONS	db2adutl delete ...	by TSM Server: RETVER or by TSM for ERP: MAX_VERSIONS	by TSM Server: RETVER or by ADINT/TSM: MAX_VERSIONS

<b>Backup Manager</b>	<b>Oracle RMAN</b>	<b>BR*Tools</b>	<b>DB2 UDB (TSM Built-in Suppt)</b>	<b>DB2 UDB (TSM for ERP)</b>	<b>SAP MaxDB</b>
TSM adapter	SBTAPI (TSM for ERP or TSM for Databases)	BACKINT (TSM for ERP) or RMAN	TSM API Client	TSM VENDOR API (TSM for ERP)	ADINT (ADINT/TSM)
Backup Repository	Oracle Control Files (optionally also RMAN Catalog)	BR*Tools Logs	DB2 History File	DB2 History File	MaxDB Backup History File

Archived

# High availability and disaster recovery concepts

In this chapter, we provide brief information about some high availability and disaster recovery options available to SAP environments and how they integrate into the Tivoli Storage Manager backup implementations. The following high availability and disaster recovery methods are described in this chapter:

- ▶ 7.1, “High availability solutions” on page 186
  - 7.1.1, “High Availability Cluster Multi-Processing (HACMP)” on page 187
  - 7.1.2, “Microsoft Cluster Service (MSCS)” on page 189
  - 7.1.3, “Oracle Real Application Cluster (RAC)” on page 190
  - 7.1.4, “Tivoli System Automation for Multiplatforms” on page 192
- ▶ 7.2, “Disaster recovery solutions” on page 194
  - 7.2.1, “HACMP Extended Distance option (HACMP/XD)” on page 194
  - 7.2.2, “Metro Mirror” on page 195
  - 7.2.3, “Oracle Maximum Availability Architecture (MAA)” on page 197
  - 7.2.4, “Oracle Dataguard” on page 198
  - 7.2.5, “DB2 High Availability Disaster Recovery (HADR)” on page 199
  - 7.2.6, “Microsoft SQL Server Log Shipping” on page 201
  - 7.2.7, “Microsoft SQL Server Mirroring” on page 201
- ▶ 7.3, “Usage matrix” on page 202

## 7.1 High availability solutions

High availability is a combination of hardware and software features that provides failover from one cluster node to another with a minimum of downtime. It is not fault-tolerant, as there are some shared resources and there is a minimal service interruption when the components fail. For applications that can withstand a short interruption, high availability systems are an excellent solution.

This section discusses the following topics:

- ▶ 7.1.1, “High Availability Cluster Multi-Processing (HACMP)” on page 187
- ▶ 7.1.2, “Microsoft Cluster Service (MSCS)” on page 189
- ▶ 7.1.3, “Oracle Real Application Cluster (RAC)” on page 190
- ▶ 7.1.4, “Tivoli System Automation for Multiplatforms” on page 192
- ▶ 7.1.5, “Other high availability solutions” on page 193

## 7.1.1 High Availability Cluster Multi-Processing (HACMP)

This is the IBM solution for AIX and Linux environments to create highly available applications. High availability is achieved by having a cluster of servers share the same SAN Storage. When the primary server crashes, the backup server can take over, as shown in Figure 7-1.

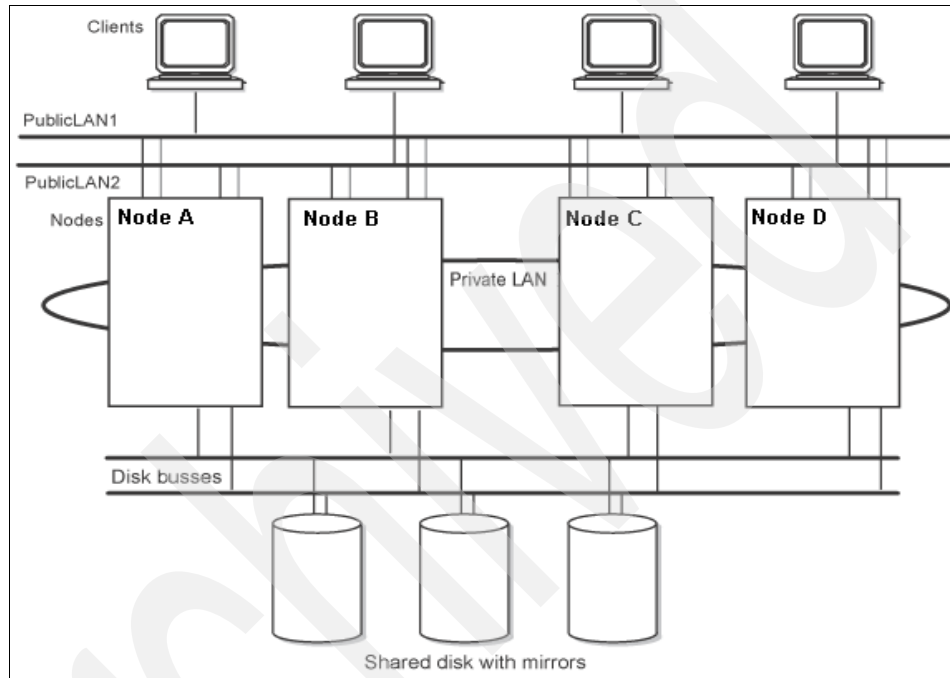

Figure 7-1 Sample high availability implementation

There are many options to implement HACMP, and all these options depend on costs. Figure 7-2 shows some of the implementation options.

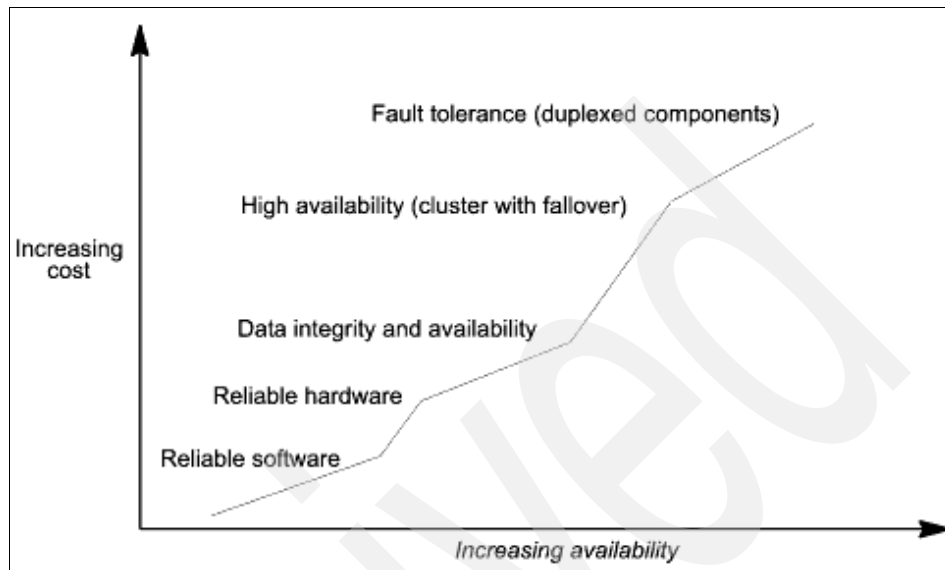

Figure 7-2 Costs and benefits of HACMP implementation

The HACMP technology provides you with a combination of physical components and software feature that provide an highly available environment built on your business requirements. HACMP has the following highlights:

- ▶ Helps reduce unplanned outages and improve system availability
- ▶ Offers ease of use through configuration wizards, auto-discovery, and a Web-based interface
- ▶ Allows backup systems to be located at a remote site for geographic disaster recovery
- ▶ Provides failover on demand to enable system maintenance without service interruption
- ▶ Offers new support for Linux to extend HACMP across IBM System p environments

Tivoli Storage Manager backups run in HACMP just as they do in an stand-alone environment. The Tivoli Storage Manager client installation switches over from the primary server to the standby server just as the other applications do. You just have to make sure that all connectivity to the storage devices and to the Tivoli Storage Manager server are the same in both servers.



Additional information about HACMP can be found at the following address:

<http://www-03.ibm.com/systems/p/advantages/ha/index.html>

## 7.1.2 Microsoft Cluster Service (MSCS)

MSCS is the cluster implementation for Windows servers and available from Microsoft.

There are different implementations (active - active, active - passive, and so on) of the Microsoft Cluster Services. The main function is being able to access applications whenever they are needed. When one server fails, another one takes over control. You can configure the cluster to have manual or automatic failover and many other configuration options.

Figure 7-3 shows a sample MSCS scenario.

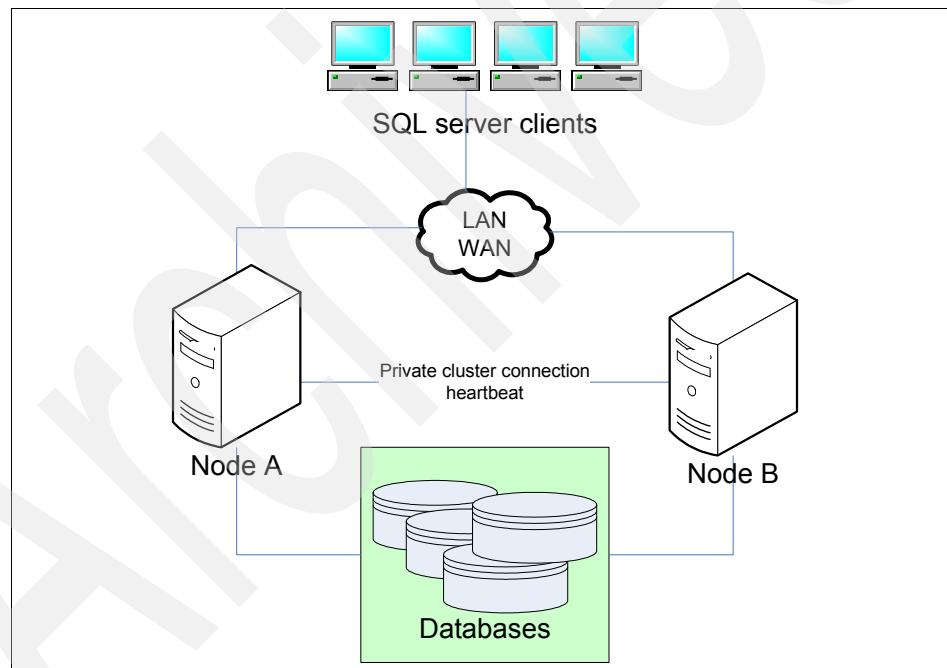

Figure 7-3 Sample MSCS scenario

Tivoli Storage Manager backups run in MSCS just as they do in an stand-alone environment. The Tivoli Storage Manager client installation switches over from the primary server to the standby server just as the other applications do. You just have to make sure that all connectivity to the storage devices and to the Tivoli Storage Manager server are the same in both servers.

**Note:** You have to install the Tivoli Storage Manager client software on a local disk on each cluster node and in the same location (directory).

Additional information about the Microsoft Cluster Services software can be found at the following address:

<http://www.microsoft.com/windowsserver2003/enterprise/clustering.msp>

### 7.1.3 Oracle Real Application Cluster (RAC)

The Oracle Real Application Cluster (RAC) is a high availability solution that provides high availability to Oracle instances and is available from Oracle.

The main concept of RAC is to have at least two nodes of database servers that share the same SAN storage or disk structure. When one node crashes or goes down, the other nodes can take over. There are different implementations that can provide load balance, network balance, or standby services.

RAC was first introduced in Oracle Version 9i and now has a wide range of features. Some interesting features are:

- ▶ Scales applications beyond the capacity of a single server
- ▶ Provides automatic load balancing among the Cluster Nodes
- ▶ Adds additional servers to the node without downtime
- ▶ Provides rolling patch application. Patches can be applied to one node at a time while the other nodes remain online and running

Figure 7-4 on page 191 shows a sample RAC scenario.

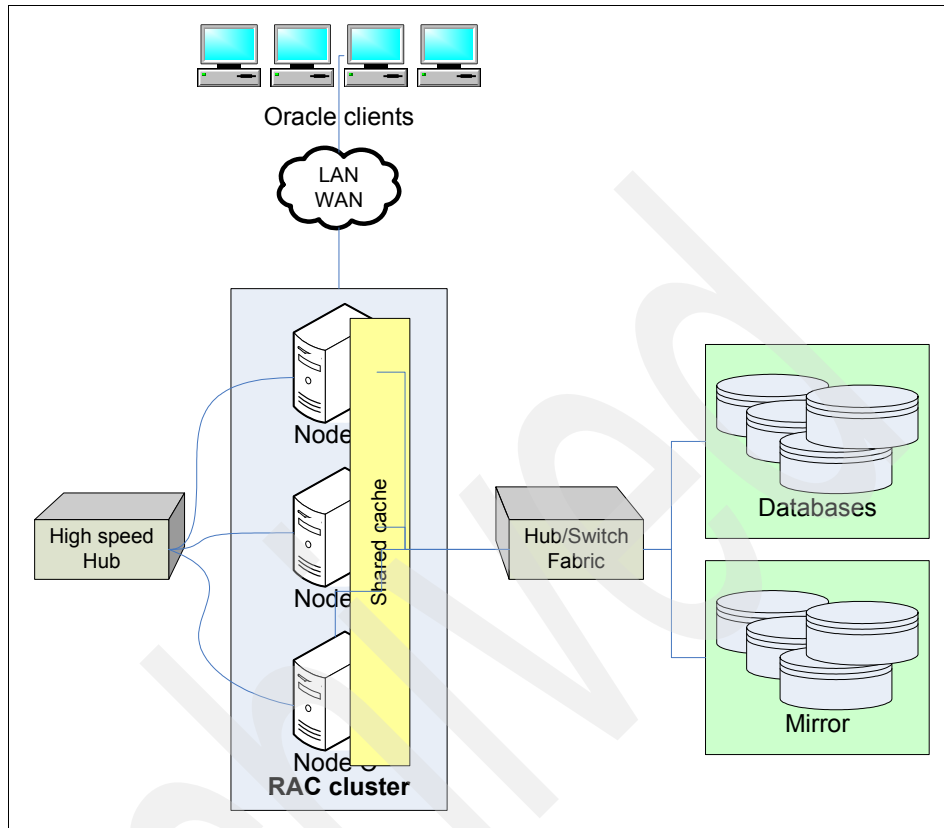

Figure 7-4 Sample Oracle Real Application Cluster (RAC) scenario

**Note:** A cluster file system (CFS) is a prerequisite for using RAC in the SAP environment. The use of raw devices or those of Automatic Storage Management (ASM) is not supported in the SAP environment (see SAP Note Number 527843, which can be found at <http://service.sap.com/sap/support/notes/527843>).

For Oracle RAC databases, you have the following backup options when using Tivoli Storage Manager:

- Hot Backup, using the standard `dsmc` client backup command. You have to properly put the database in backup mode (run `alter tablespace <tablespace name> begin backup` or `alter database begin backup`) and, when you are finished with the backup, you must turn off the backup mode (run `alter tablespace <tablespace name> end backup` or `alter database end backup`).

- ▶ Data Protection for SAP for Oracle. It is available both for the Backint and RMAN interfaces.
- ▶ Data Protection for Oracle. It is available only for the RMAN interface.

The Tivoli Storage Manager backups runs in Oracle RAC just they do in a stand-alone environment. The Tivoli Storage Manager client installation switches over from the primary server to the standby server just as the other applications do. You just have to make sure that connectivity to the storage devices and to the Tivoli Storage Manager server are available from both servers.

Additional information about Oracle RAC can be found at the following address:

<http://www.oracle.com/technology/products/database/clustering/index.html>

### **7.1.4 Tivoli System Automation for Multiplatforms**

Tivoli System Automation for Multiplatforms is an IBM product designed to provide high availability and policy-based automation for applications and services across heterogeneous environments.

The main function of this product is to increase system availability by preventing service disruptions. It provides automation and monitoring for high availability solutions from a wide range of providers (AIX HACMP, DB2 HADR, Microsoft Cluster Services, HACMP/XD, and others). Figure 7-5 on page 193 shows its conceptual architecture.

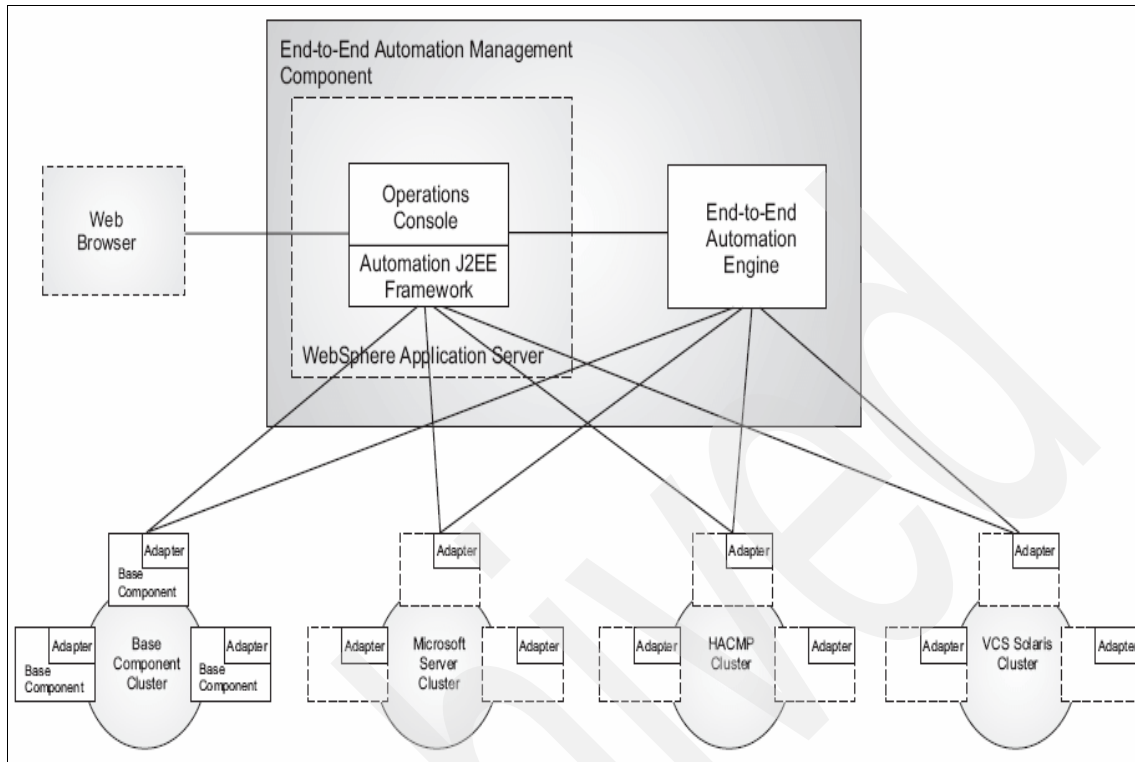

Figure 7-5 Sample Tivoli System Automation scenario

Additional information can be found in the Tivoli System Automation V3.1 documentation library at the following address:

<http://publib.boulder.ibm.com/tividd/td/IBMTivoliSystemAutomationforMultiplatforms3.1.html>

### 7.1.5 Other high availability solutions

There are many other high availability solutions from a wide range of providers. The most common solutions are:

- ▶ Veritas Cluster Server. It is available for Solaris, HP-UX, AIX, Linux, Windows, and VMware®.
- ▶ Solaris Cluster. It is available for Sun Solaris.
- ▶ HP-UX Service Guard. It is available for an HP-UX environment.
- ▶ Red Hat® Cluster. It is available for Red Hat Linux.

- ▶ Linux Cluster. It is available to some Linux distributions (confirmed this availability with your Linux provider).

## 7.2 Disaster recovery solutions

While the goal of high availability is to eliminate or reduce down time, disaster recovery focuses on protecting the environment against data loss caused by a catastrophic failure. The disaster recovery options discussed here are:

- ▶ 7.2.1, “HACMP Extended Distance option (HACMP/XD)” on page 194
- ▶ 7.2.2, “Metro Mirror” on page 195
- ▶ 7.2.3, “Oracle Maximum Availability Architecture (MAA)” on page 197
- ▶ 7.2.4, “Oracle Dataguard” on page 198
- ▶ 7.2.5, “DB2 High Availability Disaster Recovery (HADR)” on page 199
- ▶ 7.2.6, “Microsoft SQL Server Log Shipping” on page 201
- ▶ 7.2.7, “Microsoft SQL Server Mirroring” on page 201
- ▶ 7.2.8, “Other options from IBM” on page 202

### 7.2.1 HACMP Extended Distance option (HACMP/XD)

HACMP/XD is designed to ensure business continuity even in case of a disaster. This is an extension to standard HACMP. It provides automated services that keep replication and synchronization among the sites updated in real time. When a disaster occurs, all services are automatically transferred from the primary site to the remote site and all applications keep running. As soon as the primary site is restored, all data will be replicated back to the primary site and, if desired, you can enable the primary site to resume production.

HACMP/XD provides two options for replicating data to the backup site:

- ▶ Storage (hardware) based
  - ESS Metro Mirror (former PPRC)
  - SVC Metro Mirror replication
  - IBM TotalStorage DSCLI Metro Mirror replication for IBM System Storage DS8000, DS6000, and ESS 800 servers
- ▶ Host (IP) based
  - High Availability Geographic cluster (HAGEO), which is the IBM IP-based data mirroring product.
  - Geographic Logical Volume Manager (GLVM).

Figure 7-6 on page 195 shows a sample HAGEO implementation for HACMP/XD.

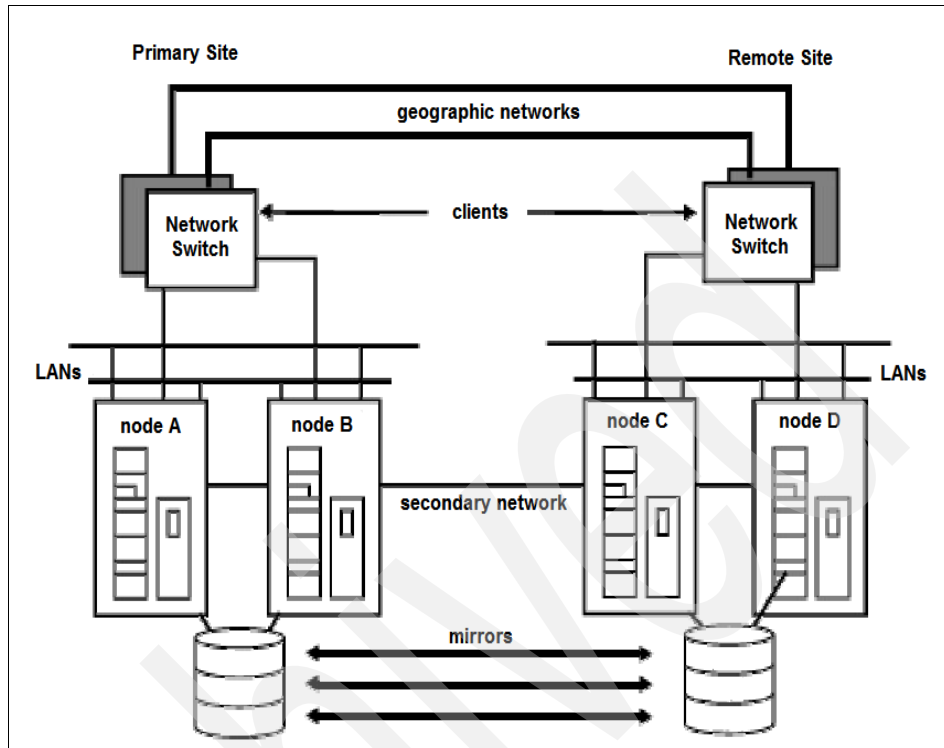

Figure 7-6 Sample HACMP/XD implementation using HAGEO

Tivoli Storage Manager backups run in HACMP/XD just as they do in a stand-alone environment. The Tivoli Storage Manager client installation switches over from the primary server to the standby server just as the other applications do. You just have to make sure that all connectivity to the storage devices and to the Tivoli Storage Manager server are the same in both servers.

Additional information about the available features can be found at the following address:

<http://www-03.ibm.com/systems/p/advantages/ha/disaster/tech.html>

## 7.2.2 Metro Mirror

Metro Mirror was formerly called Peer to Peer Remote Copy (PPRC). Metro Mirror is a feature of the IBM System Storage ESS. It provides facilities to replicate the data of a disk storage to other locations (local or remote) in safe mode.

The main function of this feature is to continuously update the target ESS Disks. The read and write protocol guarantees that the target disk is constantly updated by ensuring that the primary copy is written only if the secondary copy has been safely written. The target ESS Disk is usually located at a remote location and communication occurs over a Fibre Channel link or over ESCON®.

Figure 7-7 shows a sample Metro Mirror implementation.

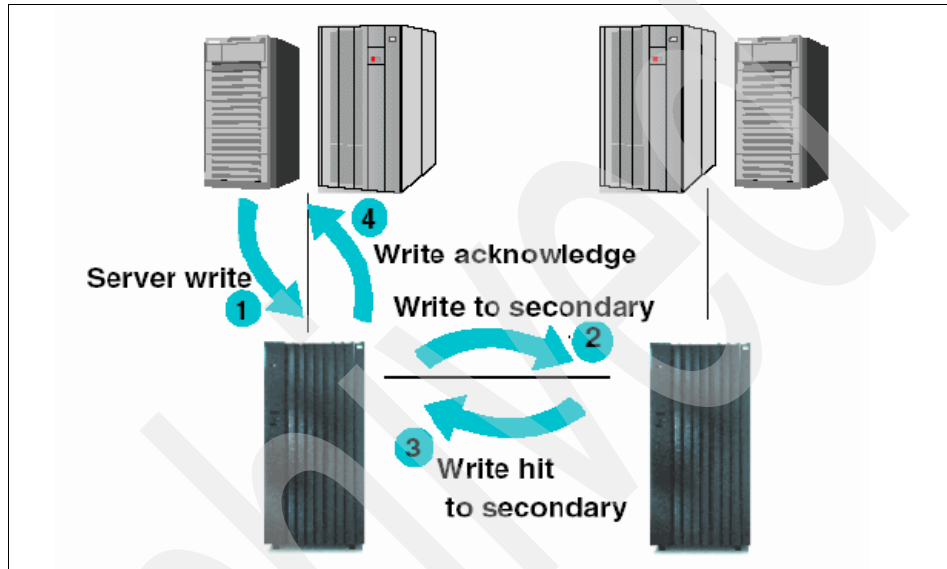

Figure 7-7 Sample Metro Mirror implementation

The main functions of Metro Mirror are:

- ▶ Provides synchronous copy (mirroring to another ESS).
- ▶ Provides a disaster recovery solution. It supports remote copy to long distance sites (at least 103 km).
- ▶ Establishes itself on a volume level.
- ▶ Provides a direct connection between ESS System using Fibre Channel or ESCON links.

**Note:** This solution is available to all SAP supported environments (DB2, Oracle, MaxDB, and Microsoft SQL Server).



### 7.2.3 Oracle Maximum Availability Architecture (MAA)

Oracle Maximum Availability Architecture (MAA) is a feature from Oracle relational database technologies that provides high availability and disaster recovery at a lower cost and complexity.

The MAA uses the best features available in all Oracle products, such as Oracle RAC, Stand by Databases (Data Guard), Grid Control, Oracle Application Server, and so on.

The sample scenario shown in the Figure 7-8 on page 198 is using the following features:

- ▶ Oracle Real Application Cluster (RAC) to provide high availability.
- ▶ Oracle Data Guard to provide disaster recovery contingency.
- ▶ The Oracle Application Cluster is replicated between two remote sites.
- ▶ Active Data Guard Option with Real-Time Query (Oracle Database 11g and above) enables the physical standby database to be open-read only while a log update is in progress. This can be used to offload impacts to the primary site by moving some `select` commands (queries) to the standby database.

**Note:** Oracle MAA is not fully supported by SAP. However, components of MAA, such as Oracle Dataguard and Oracle RAC, are supported.

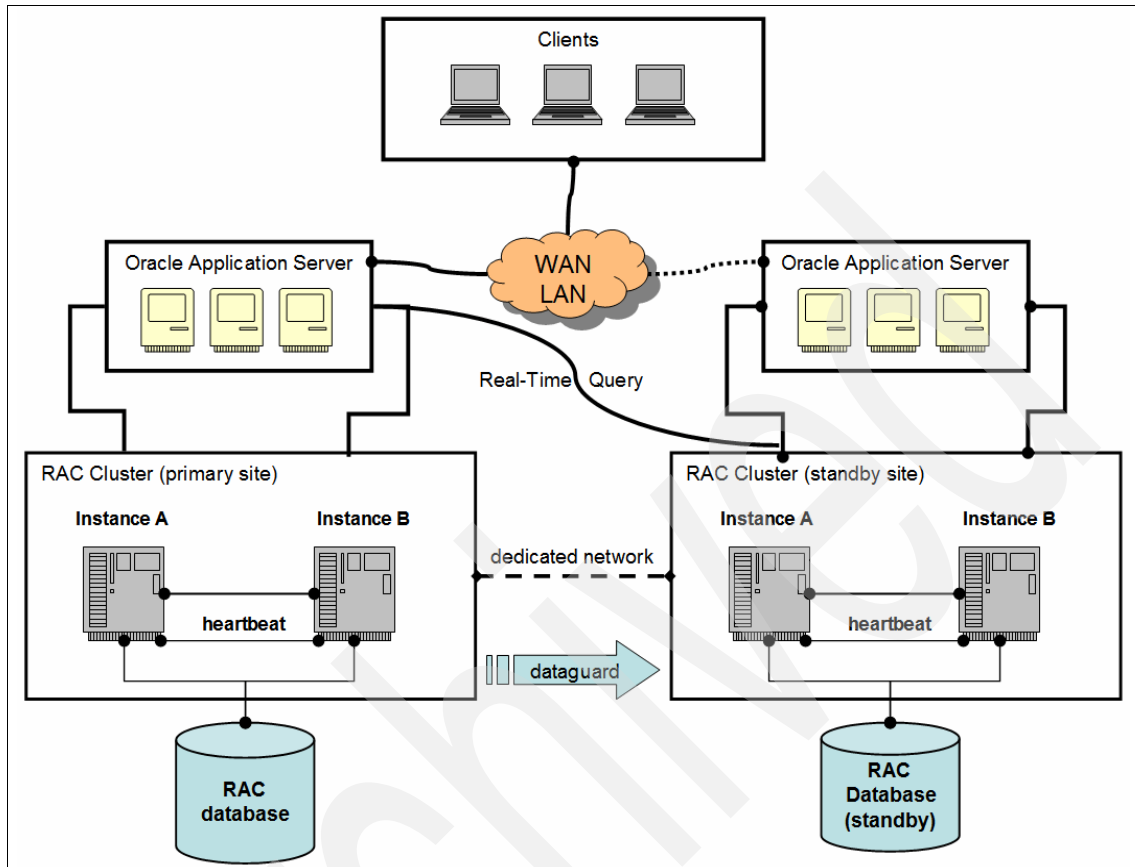

Figure 7-8 Oracle Maximum Availability Architecture sample scenario

All backup methods available for Oracle RAC remain valid for Oracle MAA.

The most up to date information about Oracle Maximum Availability Architecture can be found at the Oracle Web site at the following address:

<http://www.oracle.com/technology/deploy/availability/htdocs/maa.htm>

## 7.2.4 Oracle Dataguard

Oracle Dataguard is a solution from Oracle to provide replication between two remote sites. With this method, you have a copy of the primary database and all transaction logs (called redologs) being shipped and applied in the remote site.

In case of a disaster, you can quickly activate the standby database (which becomes the primary database). After rebuilding the original “primary database”, you can switch back to the original environment.

The standby database itself is the backup. You can back up the standby environment to avoid processing impacts to the primary database when a disaster occurs. To take the backup, you have to shut down the primary database or switch it to read only mode and then back up all database files.

The most up to date information about Oracle Dataguard can be found at the Oracle Web site at the following address:

<http://www.oracle.com/technology/deploy/availability/htdocs/DataGuardOverview.html>

## 7.2.5 DB2 High Availability Disaster Recovery (HADR)

DB2 High Availability Disaster Recovery (HADR) is available for DB2 Version 8 and later. It provides both high availability (partial site failure) and disaster recovery (complete site failure) by using the data replication feature.

When a partial site failure occurs, usually the traditional solutions take a long time to fail over to the other server. With this feature, the standby database can take over in seconds, and you are able to redirect the clients that were using the old primary database to the new primary database (standby database) using the client feature reroute or retry login in the application.

For a complete site failure (when a disaster occurs), the data consistency and availability is maintained by having the remote standby database take over as the primary database. If the original site is restored, you can restore the backup to the original site and switch over to the original primary site (failback).

There are three levels of synchronization modes to protect database data:

- ▶ Synchronous: In this mode, log writes are considered successful only when logs have been written to log files on the primary database and when the primary database has received acknowledgement from the standby database that the logs have also been written to log files on the standby database. The log data is guaranteed to be stored at both sites.
- ▶ Near synchronous: In this mode, log writes are considered successful only when the log records have been written to the log files on the primary database and when the primary database has received acknowledgement from the standby system that the logs have also been written to main memory on the standby system. Loss of data occurs only if both sites fail simultaneously and if the target site has not transferred all of the log data that it has received to nonvolatile storage.

- ▶ Asynchronous: In this mode, log writes are considered successful only when the log records have been written to the log files on the primary database and have been delivered to the TCP layer of the primary system's host machine. Because the primary system does not wait for acknowledgement from the standby system, transactions might be considered committed when they are still on their way to the standby system.

Figure 7-9 shows a sample DB2 HADR scenario.

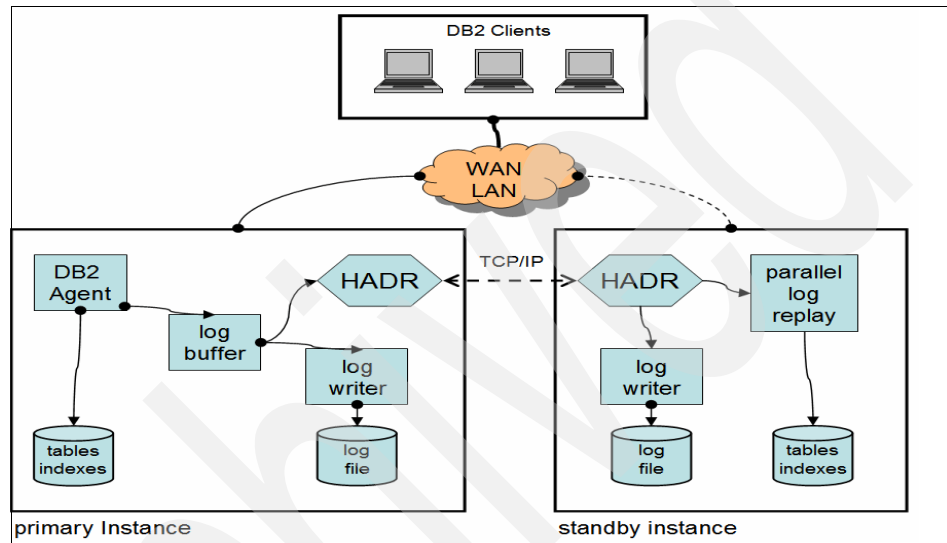

Figure 7-9 Sample DB2 HADR scenario

For DB2 HADR, you have the following available solutions to back up your databases:

- ▶ Tivoli Storage Manager for ERP for DB2
- ▶ The built-in Tivoli Storage Manager DB2 interface
- ▶ Tivoli Storage Manager for Advanced Copy Services

A technical article describing how to implement DB2 HADR on DB2 Version 8.1 can be found at the following address:

<http://www.ibm.com/developerworks/db2/library/techarticle/dm-0508zeng/>

## 7.2.6 Microsoft SQL Server Log Shipping

Microsoft SQL Server Log Shipping is a feature available in the SQL Server to increase availability by automatically shipping and restoring transactions logs to the remote database. You are able to switch over from the primary server to the secondary server and reversing the roles (the secondary becomes the primary).

The log shipping utility is available in Enterprise Manager (but not for Version 7 and earlier) as part of the Database Maintenance Plan Wizard.

A technical article from Microsoft Technet describes the functionality of the SQL Server Log Shipping implemented in the SQL Server 2000 and can be found at the following address:

<http://www.microsoft.com/technet/prodtechnol/sql/2000/reskit/part4/c1361.msp?mfr=true>

## 7.2.7 Microsoft SQL Server Mirroring

Microsoft SQL Server Mirroring was released by Microsoft for SQL Server 2005 Service Pack 1. It is designed to increase database availability by quickly copying the transaction log from the primary server to the second server. This solution provides a safe failover with no loss of committed data.

The available operating modes for database mirroring are:

- ▶ High availability: This mode supports maximum database availability by providing automatic failover and data recovery up to the last committed transaction.
- ▶ High protection: This mode provide the same data protection as high availability, but the failover is done manually.
- ▶ High performance: In this mode, the failover is done manually. The transfer of the transaction log is asynchronous. Some data loss is expected using this mode.

A technical article from Microsoft Technet describes the functionality of the SQL Server Mirroring and can be found at the following address:

<http://www.microsoft.com/technet/prodtechnol/sql/2005/dbmirror.msp>

**Note:** SQL Server Mirroring is *only* available for SQL Server 2005 Service Pack 1 (sp1) and later.

## 7.2.8 Other options from IBM

The following options can be used for disaster recovery purposes:

- ▶ DB2 Tracker, which is only available for z/OS (not covered in this book).
- ▶ DB2 Geoplex, which is only available for z/OS (not covered in this book).
- ▶ DB2 Data Propagator, which is most applicable to application disaster recovery. It can be used to recover the entire database at the remote site.

## 7.3 Usage matrix

The backup implementation should have additional configuration in order to have the backup and restore running on all those environments. Some options listed in this chapter are not fully supported by SAP. To see the currently supported options go to the following address:

<https://www.sdn.sap.com/irj/sdn/ha>

**Note:** To access the SAP Web pages, you must have a registered user name and password.

Table 7-1 shows each high availability and disaster recovery product and their availability and compatibility. We also list whether each product is supported by IBM Tivoli Systems Automation for Multiplatforms.

Table 7-1 High availability and disaster recovery usage matrix

Product	SAP support	Database supported	HA	DR	TSA support
AIX HACMP	Yes	Oracle DB2 MaxDB	Yes	No	Yes
AIX HACMP/XD	Yes	Oracle DB2	Yes	Yes	Yes
Oracle RAC	Yes (partial)	Oracle Version 9i and later	Yes	No	No
Oracle Dataguard	Yes	Oracle Version 9i and later	No	Yes	No
Oracle MAA	Yes (partial)	Oracle Version 10g and later	Yes	Yes	No

<b>Product</b>	<b>SAP support</b>	<b>Database supported</b>	<b>HA</b>	<b>DR</b>	<b>TSA support</b>
Microsoft Cluster Services (MSCS)	Yes	Oracle DB2 SQLServer MaxDB	Yes	No	Yes
Microsoft SQL Server Log Shipping	Yes	SQL Server	Yes	Yes	No
Microsoft SQL Server Mirroring	Yes	SQL Server Version 2005 sp1 and later	Yes	Yes	No
DB2 HADR	Yes	DB2 Version 8 and later	Yes	Yes	Yes
Metro Mirror (formerly PPRC)	Yes	ANY	No	Yes	Yes

Archived



## Sample implementation and operation

This part illustrates the implementation and operation of the backup and restore tools based on the Tivoli Storage Manager for SAP system. We discuss the following topics in these chapters:

- ▶ Chapter 8, “Case study introduction” on page 207
- ▶ Chapter 9, “DB2 backup using Tivoli Storage Manager” on page 213
- ▶ Chapter 10, “Oracle backup using Tivoli Storage Manager for ERP” on page 267
- ▶ Chapter 11, “LAN-free backup and restore” on page 291
- ▶ Chapter 12, “FlashCopy backup and restore” on page 319

Archived

## Case study introduction

This chapter introduces the case study. It contains an overview of the IT environment used during the project. We set up an IT environment for two implementations: one for DB2 and one for Oracle. Both setups connect to the same Tivoli Storage Manager server.

We explore the different backup solution implementations for an SAP based environment. We show the reader how to set up and configure SAP backup solutions.

The chapter contains the following sections:

- ▶ 8.1, “DB2 environment” on page 208
- ▶ 8.2, “Oracle environment” on page 208
- ▶ 8.3, “Drivers and clients mapping to server roles” on page 209

## 8.1 DB2 environment

Table 8-1 shows the list of servers for the DB2 environment.

Table 8-1 DB2 environment

Server name	Server purpose	Operating system version	Database version	Application version
hina01	SAP Central Instance	AIX V6.1	-	-
hina02	SAP Central Services Instance	AIX 5L V5.3	-	-
hina03	SAP Dialogue Instance	AIX 5L V5.3	-	-
desmoines01	SAP Database Instance	AIX V6.1	DB2 V9.1 Fix Pack 3	-
nashville01	FlashCopy mount server	AIX 6.1	-	-
lincoln02	Tivoli Storage Manager server	AIX 5L V5.3	-	Tivoli Storage Manager V5.5

Besides the servers, some storage components are set up for the case study.

- ▶ Tape library: The tape library is an IBM Total Storage 3584 with three LTO-3 tape drives.
- ▶ Disk system: The disk system is an IBM System Storage DS8000 server.

## 8.2 Oracle environment

Table 8-2 shows the list of servers for the Oracle environment.

Table 8-2 Oracle environment

Server name	Server purpose	OS version	DB version	Software version
charger01	SAP central system	AIX 5L V5.3	Oracle 10.2.0.2 <sup>a</sup>	-
nashville01	FlashCopy mount server	AIX V6.1	-	-

Server name	Server purpose	OS version	DB version	Software version
lincoln02	Tivoli Storage Manager server	AIX 5L V5.3	-	Tivoli Storage Manager V5.5

a. Oracle is installed as Oracle Real Application Cluster (RAC) V11g with GPFS™ V3.s2.

Besides the servers, some storage components are set up for the case study.

- ▶ Tape library: The tape library is an IBM Total Storage 3584 with three LTO-3 tape drives.
- ▶ Disk system: The disk system is an IBM System Storage DS4300 server.

## 8.3 Drivers and clients mapping to server roles

Table 8-3 shows a sample client configuration for hardware independent backup possibilities using Tivoli Storage Manager components.

Table 8-3 Sample hardware independent backup

Server purpose		API	TDP
SAP CI	Driver	-	-
	Client	Tivoli Storage Manager Client	Tivoli Storage Manager Client
SAP CS	Driver	-	-
	Client	Tivoli Storage Manager Client	Tivoli Storage Manager Client
SAP DI	Driver	-	-
	Client	Tivoli Storage Manager Client	Tivoli Storage Manager Client
SAP DB	Driver	-	-
	Client	DB client Tivoli Storage Manager Client	DB client Tivoli Storage Manager client TDP client
Tivoli Storage Manager	Server	Tivoli Storage Manager server	Tivoli Storage Manager server

Table 8-4 shows the LAN-free backup requirements.

Table 8-4 LAN-free backup requirements

Server purpose		LAN-free API	LAN-free TDP
SAP CI	Drivers	-	-
	Clients	Tivoli Storage Manager client	Tivoli Storage Manager client
SAP CS	Drivers	-	-
	Clients	Tivoli Storage Manager client	Tivoli Storage Manager client
SAP DI	Drivers	-	-
	Clients	Tivoli Storage Manager client	Tivoli Storage Manager client
SAP DB	Drivers	ATAPE	ATAPE
	Clients	DB client Tivoli Storage Manager client Storage agent	DB client Tivoli Storage Manager client TDP client Storage agent
Tivoli Storage Manager	Server	Tivoli Storage Manager server	Tivoli Storage Manager server

Table 8-5 lists the requirements for basic FlashCopy.

Table 8-5 Basic FlashCopy requirements

Server purpose		Flash-copy	
		API	TDP
SAP CI	Drivers	-	-
	Clients	Tivoli Storage Manager client	Tivoli Storage Manager client
SAP CS	Drivers	-	-
	Clients	Tivoli Storage Manager client	Tivoli Storage Manager client
SAP DI	Drivers	-	-
	Clients	Tivoli Storage Manager client	Tivoli Storage Manager client

Server purpose		Flash-copy	
SAP DB	Drivers	Multipath Subsystem Device Driver (SDD) Multipath SDD Path Control Module (SDDPCM)	Multipath Subsystem Device Driver (SDD) Multipath SDD Path Control Module (SDDPCM)
	Clients	DB client Tivoli Storage Manager client DP for FlashCopy Devices for mySAP DS CLI Client	DB client Tivoli Storage Manager client TDP client DP for FlashCopy Devices for mySAP DS CLI Client
FC Mount	Drivers	Multipath Subsystem Device Driver (SDD) Multipath SDD Path Control Module (SDDPCM)	Multipath Subsystem Device Driver (SDD) Multipath SDD Path Control Module (SDDPCM)
	Clients	DB client Tivoli Storage Manager client DP for FlashCopy Devices for mySAP DS CLI Client	DB client Tivoli Storage Manager client TDP client DP for FlashCopy Devices for mySAP DS CLI Client
Tivoli Storage Manager	Server	Tivoli Storage Manager server	Tivoli Storage Manager server

Table 8-6 lists the requirements for FlashCopy with Advanced Copy Services.

Table 8-6 FlashCopy with Advanced Copy Services

Server purpose		Flash-copy with ACS	
		API	TDP
SAP CI	Drivers	-	-
	Clients	Tivoli Storage Manager client	Tivoli Storage Manager client
SAP CS	Drivers	-	-
	Clients	Tivoli Storage Manager client	Tivoli Storage Manager client
SAP DI	Drivers	-	-
	Clients	Tivoli Storage Manager client	Tivoli Storage Manager client

Server purpose		Flash-copy with ACS	
SAP DB	Drivers	Multipath Subsystem Device Driver (SDD) Multipath SDD Path Control Module (SDDPCM)	Multipath Subsystem Device Driver (SDD) Multipath SDD Path Control Module (SDDPCM)
	Clients	DB client Tivoli Storage Manager client DP for FlashCopy Devices for mySAP OpenSSL CIM Server Base Providers for AIX (Pegasus) CIM Server Runtime Environment (Pegasus) DS Open API CIM Agent	DB client Tivoli Storage Manager client TDP client DP for FlashCopy Devices for mySAP OpenSSL CIM Server Base Providers for AIX (Pegasus) CIM Server Runtime Environment (Pegasus) DS Open API CIM Agent
FC Mount	Drivers	Multipath Subsystem Device Driver (SDD) Multipath SDD Path Control Module (SDDPCM)	Multipath Subsystem Device Driver (SDD) Multipath SDD Path Control Module (SDDPCM)
	Clients	DB client Tivoli Storage Manager client DP for FlashCopy Devices for mySAP OpenSSL CIM Server Base Providers for AIX (Pegasus) CIM Server Runtime Environment (Pegasus) DS Open API CIM Agent	DB client Tivoli Storage Manager client TDP client DP for FlashCopy Devices for mySAP OpenSSL CIM Server Base Providers for AIX (Pegasus) CIM Server Runtime Environment (Pegasus) DS Open API CIM Agent
Tivoli Storage Manager	Server	Tivoli Storage Manager server	Tivoli Storage Manager server



## DB2 backup using Tivoli Storage Manager

This chapter discusses the practical experience on implementing SAP data protection using Tivoli Storage Manager for ERP (DB2) and DB2 built-in Tivoli Storage Manager support. Both solutions implement LAN-free backup transfers from the client node to Tivoli Storage Manager server and vice versa. The chapter is based on a case study tested in a lab environment. The objective of the case study was to implement a Tivoli Storage Manager solution that meets the requirements given by the case study.

The chapter consists of the following sections:

- ▶ 9.1, "Introduction" on page 214
- ▶ 9.2, "Planning for Data Protection for SAP with DB2" on page 215
- ▶ 9.3, "Configuration of Storage Agent" on page 221
- ▶ 9.4, "Configuration for DB2 backup" on page 221
- ▶ 9.5, "Backup and restore using DB2 and the API client" on page 235
- ▶ 9.6, "Tivoli Storage Manager for ERP-DB2 installation" on page 243
- ▶ 9.7, "Tivoli Storage Manager for ERP configuration" on page 247
- ▶ 9.8, "Backup and restore using Data Protection for SAP" on page 256
- ▶ 9.9, "Troubleshooting" on page 262
- ▶ 9.10, "References" on page 265

## 9.1 Introduction

There are several mechanism for backing up DB2 database with Tivoli Storage Manager. We explore some of the most common SAP backup processes with DB2 database in this section. They are:

- ▶ 9.1.1, “Data protection for SAP and DB2” on page 214
- ▶ 9.1.2, “DB2 built-in Tivoli Storage Manager support” on page 215

### 9.1.1 Data protection for SAP and DB2

Once configured, Data Protection for SAP operates as an invisible link between DB2 and the SAP-DB2 Administration Tools on one hand and Tivoli Storage Manager on the other. A shared library is dynamically linked by DB2 backup/archive processes and by the SAP utilities, as shown in Figure 9-1.

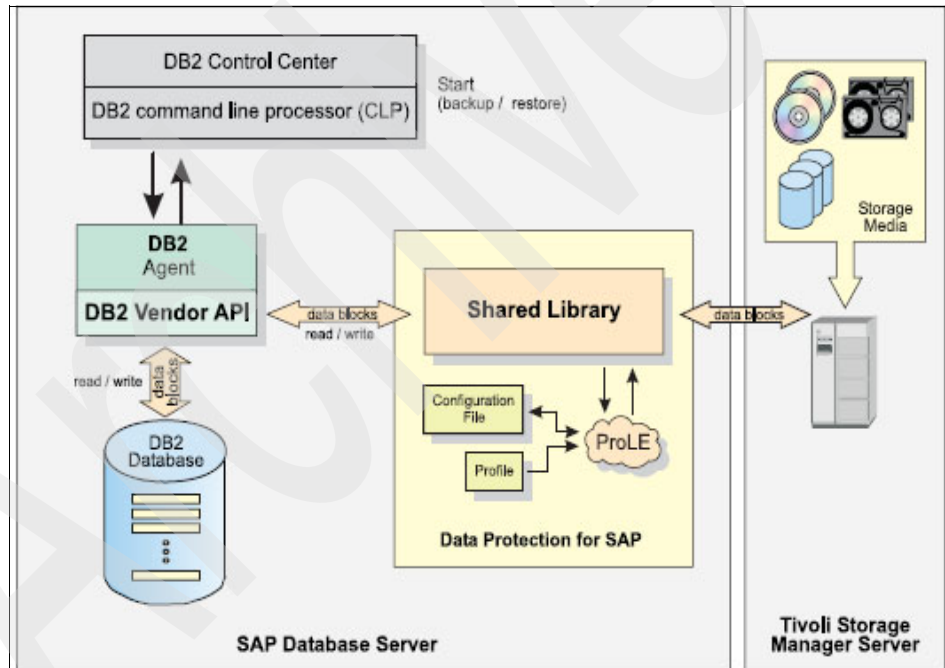

Figure 9-1 Integration of Data Protection for SAP with DB2

The Data Protection for SAP package also contains the Administration Assistant, aimed at increasing the administrator’s productivity. The Administration Assistant typically resides on a different server and communicates with Data Protection for SAP using TCP/IP. It can control several instances of Data Protection for SAP. Its

functionality covers configuring an instance of Data Protection for SAP, data transfer performance monitoring, and monitoring of the backup status of connected SAP systems.

## 9.1.2 DB2 built-in Tivoli Storage Manager support

The DB2 built-in support for Tivoli Storage Manager allows a DB2 backup process to invoke the Tivoli Storage Manager API directly. The API then transfers the backup data to Tivoli Storage Manager for storage. Figure 9-2 shows the processing of DB2 built-in support.

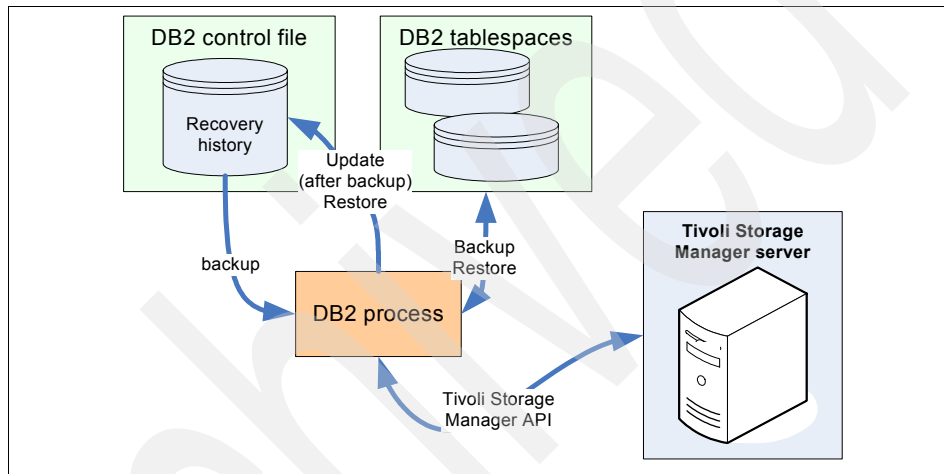

Figure 9-2 Data Protector for SAP for DB2

## 9.2 Planning for Data Protection for SAP with DB2

We want to illustrate the implementation of Tivoli Storage Manager for ERP. There are two types of DB2 data protection:

- ▶ DB2 UDB: Tivoli Storage Manager built-in support (DB2 communicates with the Tivoli Storage Manager server through the Tivoli Storage Manager API Client)
- ▶ DB2: Tivoli Storage Manager for ERP (DB2 uses the API library provided by Tivoli Storage Manager for ERP as an adaptor to transfer data to Tivoli Storage Manager server)

We test both settings mentioned above.

This section discusses the following topics:

- ▶ 9.2.1, “Lab environment overview and backup consideration” on page 216
- ▶ 9.2.2, “Backup methods to be used” on page 218
- ▶ 9.2.3, “Installation prerequisites” on page 218
- ▶ 9.2.4, “Tivoli Storage Manager software packages to be used” on page 219
- ▶ 9.2.5, “Defining backup policies” on page 219

## 9.2.1 Lab environment overview and backup consideration

In our lab environment, an SAP central instance and database server are located on the same partition running AIX Version 6.1. The host name of the SAP partition is desmoines01. The host name of the Tivoli Storage Manager server is lincoln02, which is running AIX V6.1. We use Tivoli Storage Manager Version 5.5.0.0.

SAP system data is stored in DB2 UDB Version 9.1. The SID of our database is QAS. The size of database QAS is around 100 GB. The service level requirements on the backup solution are shown in Table 9-1.

*Table 9-1 Parameters required for DB2 backup and restore*

Parameter	Required value
Application	SAP
Recovery Time Objective (RTO)	20 minutes
Recovery Point Objective (RPO)	3 hours
Data size	100 GB
Backup retention	30 days
Data type	DB2 database
Database in archive mode	Yes
Recovery Time Granularity (RTG)	Any point in time

A tape library with three LTO3 drives is attached to the Tivoli Storage Manager server through a 2 Gbps SAN network. Table 9-2 lists the performance characteristics of Linear Tape Open (LTO) drives.

*Table 9-2 LTO drive characteristics*

Drive type	Cartridge capacity native/compressed (GB)	Drive throughput native /compressed (MBps)	File access time (seconds)
LTO4	800/1600	120/240	100

Drive type	Cartridge capacity native/compressed (GB)	Drive throughput native /compressed (MBps)	File access time (seconds)
LTO3	400/800	80/160	68
LTO2	200/400	35/70	49
LTO1	100/200	15/30	54

Based on Table 9-2 on page 216, the performance parameters of LTO3 drive are as follows:

- ▶ Transfer rate of 80 MBps (native)/160 MBps (with data compression)
- ▶ Cartridge capacity of 400 GB (native)/800 GB (with data compression)

The device class TAPE defined on the Tivoli Storage Manager server for the library is of type ULTRIUM3C. The suffix C in ULTRIUM3C indicates that hardware compression is enabled on the LTO3 drives.

Tivoli Storage Manager server is connected to the SAP server through a 1 Gbps LAN. According to Table 9-3, we can expect a real transfer speed of 180 GB/hr.

*Table 9-3 Common LAN throughputs*

Technology	MBps	Assume speed
Fast Ethernet	100 MBps	18 GB/hr at 40% efficiency
Gigabit Ethernet	1000 MBps	180 GB/hr at 40% efficiency
T1	1.54 MBps	0.5 GB/hr at 80% efficiency
T3	45 MBps	16 GB/hr at 80% efficiency

From the information in Table 9-1 on page 216, we can deduce that the throughput required on restore has to be at least 100 GB/20 minutes (RTO) = 300 GB/hr. The throughput limit of LTO3 drive is around 280 GB/hr (native)/560 GB/hr (with compression enabled) and the throughput limit of 1 Gbps LAN with 40% efficiency can be as much as 180 GB/hr.

According to the considerations above, in our environment, 100 GB of data can be transferred from the tape to an SAP server in around 35 minutes. The minimal requirement throughput for database restore is 300 GB/hr. Most likely, this cannot be achieved using LAN transfers.

We must consider an enhanced data transfer mechanism. As the SAP server is equipped with a secondary Fibre Channel HBA adapter, we can implement a LAN-free solution. For the LAN-free implementation, we could use SAN zoning to

enable the SAP server to directly access LTO3 drives in the tape library through SAN. In the case of a LAN-free solution, the bottleneck for data transmission would likely be on the LTO3 tape drive. As we use compression on drive, the required bandwidth should be achievable (the maximal LTO3 drive throughput with compression enabled can be as much as 560 GB/hr).

## 9.2.2 Backup methods to be used

For our first step, we set up a backup solution based on DB2 Tivoli Storage Manager built-in support. We use DB2 backup functions to trigger backup and restore of the database.

For our second step, we set up a backup solution based on Tivoli Storage Manager for ERP (DB2). This solution calls the backup and restore functions by using the Backup Object Manager (backom), a component of Tivoli Storage Manager for ERP.

## 9.2.3 Installation prerequisites

The following products must be installed before you can start setting up Tivoli Storage Manager for DB2 backup:

- ▶ A supported operating system for SAP and Tivoli Storage Manager client
- ▶ DB2 UDB database
- ▶ SAP or SAP e-business Solution, based on DB2 UDB
- ▶ Tivoli Storage Manager client

For hardware and software prerequisites, as well as product versions supported and maintenance levels required by the current version of Data Protection for SAP and the Administration Assistant, refer to the Release Notes file in the Tivoli Information Center, found at the following address:

[http://publib.boulder.ibm.com/infocenter/tivihelp/v1r1/index.jsp?topic=/com.ibm.itsmreadme.doc\\_5.5/relnote\\_erp550.html](http://publib.boulder.ibm.com/infocenter/tivihelp/v1r1/index.jsp?topic=/com.ibm.itsmreadme.doc_5.5/relnote_erp550.html)

The version of Tivoli Storage Manager Backup Archive client and API client must be compatible with Tivoli Storage Manager server version and the operating system version. The newest version of the Tivoli Storage Manager API and the Backup-Archive Client can be found at the following address:

<ftp://index.storsys.ibm.com/tivoli-storage-management/maintenance/>

On AIX, you can use the **bootinfo -y** command to get the kernel version (the 32- or 64-bit implementation).

## 9.2.4 Tivoli Storage Manager software packages to be used

For the solution based on DB2 Tivoli Storage Manager built-in support, the following software components are used:

- ▶ Tivoli Storage Manager Client API 64-bit Version 5.5.0.0
- ▶ Tivoli Storage Manager Backup Archive Client Version 5.5.0.0
- ▶ Tivoli Storage Manager for Storage Area Networks Version 5.5.0.0
- ▶ Atape driver 10.7.3.0

For the solution based on Tivoli Storage Manager for ERP (DB2), the following software components are used for this solution:

- ▶ Tivoli Storage Manager Client API 64-bit Version 5.5.0.0
- ▶ Tivoli Storage Manager Backup Archive Client Version 5.5.0.0
- ▶ Tivoli Storage Manager for Storage Area Networks Version 5.5.0.0
- ▶ Tivoli Storage Manager for Enterprise Resource Planning (DB2) Version 5.5.0.0
- ▶ Atape driver 10.7.3.0

## 9.2.5 Defining backup policies

According to the calculations given in 9.2.1, “Lab environment overview and backup consideration” on page 216, restoring a 100 GB database can be accomplished in less than 20 minutes if we implement the solution based on the LAN-free backup.

The database operates in archive mode and the point in time restore option is required. Therefore, in addition to backing up data in DB2 containers, the solution also backs up offline logs generated by DB2. The backup of DB2 logs is performed using DB2 Log Manager for both solutions: Tivoli Storage Manager for ERP and DB2 built-in support for Tivoli Storage Manager. Thus, the logs will be transferred to Tivoli Storage Manager right after they go offline. This solution meets the recovery point limit given by the Recovery Point Objective (RPO), which is 3 hours.

To minimize the number of log files needed for point in time recovery, we schedule a full online backup of the database every 24 hours. The backup retention required on this solution is 30 days. Therefore, we can assume that the total size of all backup images will be  $30 \times 100 \text{ GB} = 3 \text{ TB}$ . Also, we must consider the space on the backup storage required for offline redo log files. For our database, we assume that it is approximately 500 to 1000 MB for 30 days. In general, the space required for backups of redo logs depends on the volume of transactions on the database.

Therefore, we calculate that the total storage requirements of the backup media is 4 TB. This would require five LTO3 cartridges.

### **General considerations**

In our lab environment, we set up a tape storage pool as a destination for DB2 database backups. These backups are transferred LAN-free, which means directly from the SAP server to a LTO3 tape drive through SAN network. The transfers of large files can use the full backup throughput of the sequential medium.

The backup of offline log files is triggered by DB2 Log Manager whenever the next log is ready for backup. To avoid a tape mount every time the log backup is performed, we use a disk-tape storage pool hierarchy for the backup of log files. Thus, the logs backup is stored in the disk storage pool first. As soon as the storage pool fills to 70%, the migration process at the Tivoli Storage Manager server will be triggered. The migration process will move data from the disk storage pool to the tape storage pool.

### **Backup retention**

The retention period required for backup for this solution is 30 days.

- ▶ In the solution based on DB2 built-in Tivoli Storage Manager support, the backup retention is controlled by the program DB2ADUTL. DB2ADUTL is called from the backup script every time after the full backup finishes. It removes all the obsolete backup versions and keep just the last 30 versions. As a full backup is scheduled on a daily basis, the retention can cover a period of the last 30 days. DB2ADUTL also removes all the offline logs backed up in Tivoli Storage Manager that are older than the oldest full backup version.
- ▶ In the solution based on Tivoli Storage Manager for ERP, the deletion of obsolete backup versions is driven by Tivoli Storage Manager for ERP. Therefore, both archive copy groups for data files backup and log files backup are configured with parameter RETVER=NOLIMIT, so that the files are not considered expired and deleted by the Tivoli Storage Manager server. You can enable versioning by using the parameter MAX\_VERSIONS in the Tivoli Storage Manager for ERP configuration file (`init<SID>.ut1`). The required backup retention period is 30 days and we plan to trigger a full backup daily. Therefore, we set MAX\_VERSIONS=30.



## 9.3 Configuration of Storage Agent

The configuration of the storage agent is discussed extensively in the LAN-free backup discussion in 11.3, “Setup and configuration of storage agent” on page 302.

## 9.4 Configuration for DB2 backup

The configuration for DB2 built-in Tivoli Storage Manager support is performed in the following sections:

- ▶ 9.4.1, “Configuration on the Tivoli Storage Manager server” on page 221
- ▶ 9.4.2, “Data protection configuration on SAP server” on page 225
- ▶ 9.4.3, “Optional DB2 configurations” on page 230
- ▶ 9.4.4, “Schedule configuration” on page 231

### 9.4.1 Configuration on the Tivoli Storage Manager server

The correct configuration of the DB2 environment includes the following definitions:

- ▶ **Management class:** Every data object is bound to a management class when it is sent to the Tivoli Storage Manager server. It determines how the object is managed on the Tivoli Storage Manager server. For DB2, you must define:
  - Backup management class for database backup
  - Archive management class for the database logs
- ▶ **Backup/Archive Copygroup:** Each management class can contain one archive copygroup and one backup copygroup. The copygroup is the final structure in the Tivoli Storage Manager policy management scheme and contains the initial destination storage pool of the data object and the retention policy applied as the backup object.
  - The backup copygroup must be set up using the following values:  
verexists=1  
verdeleted=0  
retextra=0  
retonly=0
  - The archive copygroup must be set up using the RETVER=NOLIMIT value.

- ▶ Backup policy: This policy defines how many tapes are required and for how long you have to keep those tapes. The incorrect definition of these policies affect your tape management operations by using more tape as required or having no data to be restored due to the Tivoli Storage Manager Server or DB2 expiration process.
- ▶ The node chosen to back up your database should be allowed to remove backups/archive from Tivoli Storage Manager server.

The backup load from the database usually goes directly to tape, as it can exploit the sequential method. Make sure you have a tape storage pool in place. For the archive load, the data should be sent first to disk due to the repetitive nature of the archive process to avoid the frequent tape mounts of automatic log archival.

If there are multiple DB2 databases under one DB2 instance, all databases make use of the same Tivoli Storage Manager client API setup. This means all the database backups are using the same management class to which this Tivoli Storage Manager node belongs.

Perform the following steps on the Tivoli Storage Manager server:

1. We define a policy domain DATABASE\_API with management class DATABASE. We assign this management class as a default management class for this policy domain.
2. We also define the BACKUP copy group and the ARCHIVE copy group within the management class DATABASE. The retention of backup images of the database are controlled by the DB2 utility DB2ADUTL as well as the retention of redo logs backups.
  - The policy rules of the BACKUP copy group apply to DB2 backups. It has the options of VEREX=1, VERDEL=0, RETEX=0, and RETONLY=0.
  - The policy rules of the ARCHIVE copy group will apply to DB2 offline logs backups. It has the option of RETVER=nolimit.

The overall setup is shown in Figure 9-3 on page 223.

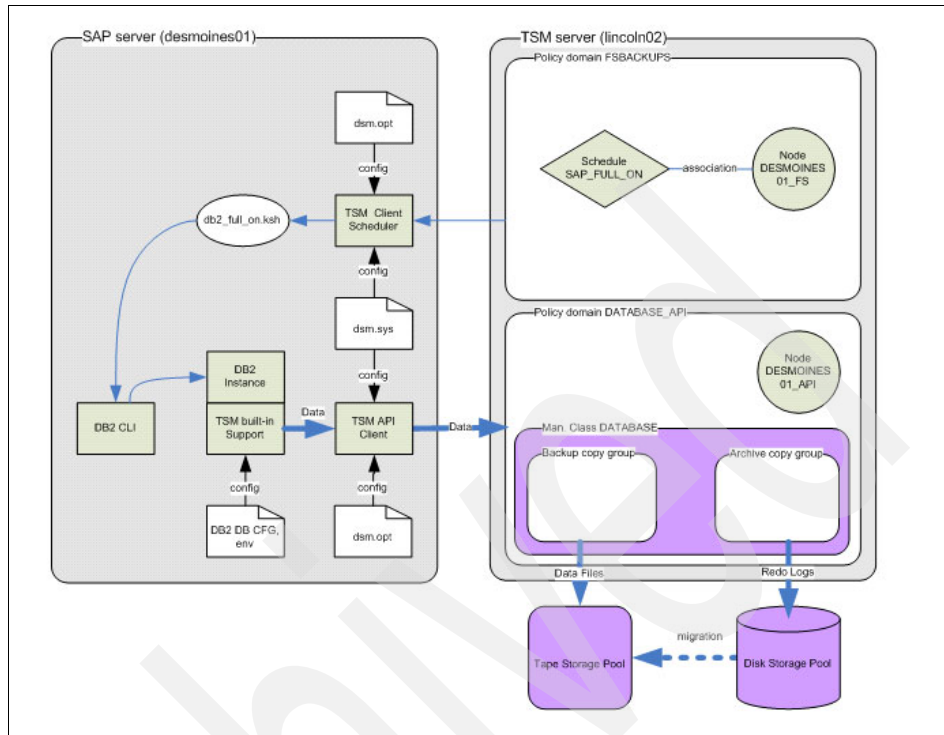

Figure 9-3 DB2 built-in Tivoli Storage Manager support principles

3. For the BACKUP copy group in the DATABASE management class, the destination storage pool, BACKUPTAPE, is of device type TAPE. For the archive copy group in the DATABASE management class, the destination storage pool, BACKUPDISK, is of type DISK.

Storage pools (stgpool) represent the actual physical devices that hold backup archive data. Each copy group, backup, or archive sends data to the destination storage pool. You should create specific storage pools for each target destination in Tivoli Storage Manager.

Other options that are important are:

- Collocation: Specifies which objects would reside in the same tape volumes.
  - Migration: Migration rule from one pool to another (disk to tape).
  - Reclamation: Rule for reclaiming unused backup versions.
4. Storage pool BACKUPTAPE is the next storage pool for storage pool BACKUPDISK in the storage hierarchy. Therefore, data from BACKUPDISK is automatically migrated to BACKUPTAPE.

The maximum size of data that a storage pool can handle is specified in the MAXSIZE parameter. If an object is larger than MAXSIZE, Tivoli Storage Manager checks the next storage pool hierarchy (typically tape). If the data object is larger than the MAXSIZE of all storage pools in the hierarchy, then the Tivoli Storage Manager server rejects that object. The maximum size specification allows you to send a really large object directly to tape without putting it temporarily to disk and migrating it to tape.

5. The Tivoli Storage Manager client must authenticate to the Tivoli Storage Manager server using a node name and password. A node is registered at the Tivoli Storage Manager by the Tivoli Storage Manager administrator using the REGISTER NODE command. The following are the parameters for the registration:

<b>NODENAME</b>	Specifies the name of the client node to be registered. The maximum length of the name is 64 characters.
<b>PASSWORD</b>	Specifies the client node's password. The maximum length of the name is 64 characters. The password is not case-sensitive.
<b>DOMAIN</b>	Specifies the name of the policy domain to which the node is assigned. If you do not specify a policy domain name, the node is assigned to the STANDARD policy domain.
<b>ARCHDELETE</b>	Specifies whether the client node can delete its own archive files from the server. The parameter is optional. The default value is YES.
<b>BACKDELETE</b>	Specifies whether the client node can delete its own backup files from the server. The parameter is optional. The default value is NO.
<b>MAXNUMMP</b>	Specifies the maximum number of mount points a node is allowed to lose on the server or storage agent. The parameter is optional. The default value is 1. You can specify an integer from 0-999. A value of 0 specifies that a node cannot acquire any mount point for a backup or archive operation. The server, however, will still allow the node a mount point for a restore or retrieve operation.

**Note:** Your database node should have the values of BACKDELETE and ARCHDELETE set to YES. If these values is set to NO, the `db2adut1 delete` command cannot manually deactivate the DB2 backup and archive objects and they will reside on Tivoli Storage Manager storage forever.

We register the Tivoli Storage Manager node with the DATABASE\_API policy domain and set the parameters for Tivoli Storage Manager node, as shown in Example 9-1.

*Example 9-1 Tivoli Storage Manager node registration*

---

```
TSM1>reg node desmoines01_api passwd=desmoines01_api backdel=yes  
maxnummp=2
```

---

## 9.4.2 Data protection configuration on SAP server

The configuration of the SAP server is as follows:

1. We modify the configuration of the Tivoli Storage Manager API client in the `dsm.sys` file in `/usr/tivoli/tsm/client/api/bin64`. The listing of the file is provided in Example 9-2. In the file, we define server stanzas `TSM1_API_DB2` and `TSM1_FS`. `TSM1_API_DB` uses the storage agent for LAN-free backup, while the file system backup uses the default backup archive client.

*Example 9-2 API client configuration dsm.sys*

---

```
SErvername TSM1_FS  
  COMMethod      TCPip  
  TCPPort        1500  
  TCPServeraddress lincoln02  
  passwordaccess generate  
  nodename       desmoines01_fs  
  
SErvername TSM1_API_DB2  
  COMMethod      TCPip  
  TCPPort        1500  
  TCPServeraddress lincoln02  
  passwordaccess generate  
  nodename       desmoines01_api  
  enablelanfree yes
```

---

2. The Tivoli Storage Manager node `desmoines01_fs` is a member of policy domain `FSBACKUPS`. All the schedules associated with `desmoines01_fs` must be defined in the same policy domain. The value of parameter `PASSWORDACCESS` in `TSM1_FS` stanza is `generate`. This allows Tivoli Storage Manager Backup Archive Client and Tivoli Storage Manager Client Scheduler to store the password locally after a prompt on the initial invocation. The client scheduler can be started automatically using `/etc/inittab`.

- We use the same `dsm.sys` profile file for Tivoli Storage Manager Backup Archive Client and Tivoli Storage Manager for ERP. We create a symbolic link called `dsm.sys` in the Tivoli Storage Manager Backup Archive installation directory pointing to `dsm.sys` in the Tivoli Storage Manager API directory, as shown in Example 9-3.

*Example 9-3 Created link to dsm.sys file*

---

```
ln -s /usr/tivoli/tsm/client/api/bin64/dsm.sys
/usr/tivoli/tsm/client/ba/bin/dsm.sys
```

---

- We create the Tivoli Storage Manager API Client configuration file `dsm_api.opt` under `/usr/tivoli/tsm/client/api/bin64`. It refers to the `SERvername` stanza in `dsm.sys`. The contents of `dsm_api.opt` are shown in Example 9-4.

*Example 9-4 API Client configuration file*

---

```
SERvername TSM1_API_DB2
```

---

- We adjust the `db2qas` user's profile by adding the Tivoli Storage Manager API variables `DSMI_DIR`, `DSMI_CONFIG`, and `DSMI_LOG`. We created the error log directory `/var/log/tsm`, and adjusted the access rights to enable the `db2qas` user to perform read and write operations to the log directory using the command `chmod ugo+rw /var/log/tsm`. Because the user is using a C-shell, we add the lines shown in Example 9-5 from `.cshrc_profile`.

*Example 9-5 Lines added to .cshrc\_profile of the db2qas user*

---

```
setenv DSMI_DIR /usr/tivoli/tsm/client/api/bin64
setenv DSMI_CONFIG /usr/tivoli/tsm/client/api/bin64/dsm_api.opt
setenv DSMI_LOG /var/log/tsm
```

---

- We temporarily export the variables `DSMI_DIR` and `DSMI_CONFIG` from the root user's environment and established the password for Tivoli Storage Manager node (`desmoines01_api`) using the `DSMAPIPW` utility, as shown in Example 9-6.

*Example 9-6 Establishing the password for Tivoli Storage Manager node*

---

```
# export DSMI_DIR=/usr/tivoli/tsm/client/api/bin64
# export DSMI_CONFIG=/usr/tivoli/tsm/client/api/bin64/dsm_api.opt
# cd /db2/db2qas/sql1lib/adsm/
# ./dsmapipw
*****
* Tivoli Storage Manager *
* API Version = 5.5.0 *
*****
```

```
Enter your current password: XXXXX
Enter your new password: XXXXX
Enter your new password again: XXXXX
```

Your new password has been accepted and updated.

---

7. We restart the SAP system and DB2 instance to reflect the environment settings modified in step 5 on page 226. The commands are listed in Example 9-7.

*Example 9-7 Restarting SAP and DB2*

---

```
# su - qasadm
$ stopsap
$ startsap
```

---

8. We modify the DB2 database configuration settings to instruct DB2 Log Manager to send offline logs to Tivoli Storage Manager using the Tivoli Storage Manager API client. We do not explicitly specify the management class, so the default management class in the policy domain is used. We also update the database configuration parameter FAILARCHPATH, which specifies the path where the offline log files would be placed if the primary archive destination (Tivoli Storage Manager server) is unavailable. The commands are listed in Example 9-8.

*Example 9-8 Updating DB2 database configuration*

---

```
$ su - db2qas
$ db2 update db cfg for QAS using LOGARCHMETH1 TSM
$ db2 update db cfg for QAS using FAILARCHPATH /db2/QAS/log_archive
```

---

### **Option file and error log**

The root user must create or modify the Tivoli Storage Manager system options file, `dsm.sys`, which must be located in the `/usr/tivoli/tsm/client/api/bin` directory.

The sample `dsm.sys.smp` and `dsm.opt.smp` files in the `/usr/tivoli/tsm/client/api/bin` directory provides the basic information needed for DB2 backup to work.

Example 9-9 shows the dsm.sys file in our environment.

*Example 9-9 Our dsm.sys*

---

```
*****
* Tivoli Storage Manager
*****
SErvername TSM_API
  COMMMethod      TCPip
  TCPPort         1500
  TCPServeraddress 9.3.65.141
  nodename        desmoines01_API
  passwordaccess  generate
  errorlogname    /usr/tivoli/tsm/client/ba/bin/dsmerror_API.log

SErvername TSM_FS
  COMMMethod      TCPip
  TCPPort         1500
  TCPServeraddress 9.3.65.141
  nodename        desmoines01_FS
  passwordaccess  generate
  Compression     off
  Txnb            25600
  Tcpw            63
  Tcpb            32
  tcpnodelay     yes
  errorlogname    /usr/tivoli/tsm/client/ba/bin/dsmerror_FS.log
```

---

Example 9-10 shows the dsm.opt file from our environment.

*Example 9-10 Our dsm.opt file*

---

```
*****
* Tivoli Storage Manager
*****
*
* SErvername      A server name defined in the dsm.sys file
*
SErvername TSM_API * Name of the stanza
```

---

The error log is the file specified by the ERRORLOGNAME in the dsm.sys or the DSIERROR.LOG file that is located in the DSMI\_LOG directory. That file must be set to a path that the database user of the application can write to. If the user performing the backup and restore does not have write permissions to the log



file, the process will fail. The Tivoli Storage Manager API return code for this situation is 106 (Access to the specified file or directory is denied).

## Password handling

Each Tivoli Storage Manager client must have a password to access a server. The root user must run **dsmapiw** from the `$HOME/sql11ib/adsm` directory of the instance owner to establish and reset the Tivoli Storage Manager password. Make sure that the correct DSMI environment variables are set when the root user executes the **dsmapiw** program. When executed, the **dsmapiw** program prompts you for the:

- ▶ Old password, which is the current password for the Tivoli Storage Manager node stored in the server.
- ▶ New password, which is the new password for the node.

You should check that a new file was created in the `/etc/security/adsm` directory that contains the encrypted password. The name of this file is the same as the value specified for the `servername` option in the `dsm.opt` file.

If you receive any errors, you should look at the `dsierror.log` file, which shows any API error messages. For a listing of API error messages, refer to *Tivoli Storage Manager Using the Application Program Interface V4R1*, SH26-4123.

**Note:** The `passwordaccess` parameter must be set to generate. This parameter specifies that Tivoli Storage Manager Client encrypts and stores the user password locally and generates a new password when the old one expires. DB2 is then not required to supply a password each time it initializes a session with the Tivoli Storage Manager server. If you use the `db2` command to store any parameters into DB2, `passwordaccess` must be set to prompt.

## Configuring the Tivoli Storage Manager client API

To configure the Tivoli Storage Manager client, you must perform the following tasks:

- ▶ Set environment variables: The environment variables that are used are `DSMI_CONFIG`, `DSMI_DIR`, and `DSMI_LOG`.
  - `DSMI_DIR`: Identifies the directory path where the agent file, `dsmtca`, is located.
  - `DSMI_CONFIG`: Identifies the full directory path and file name of the Tivoli Storage Manager user options file, `dsm.opt`. This file contains the name of the server to be used.
  - `DSMI_LOG`: Identifies the directory path where the error log file, `dsierror.log`, is to be created.

- ▶ Create client option file and specify options: The client options file is a plain text file, and the default name of this file is `dsm.opt`. On UNIX systems, the client options file is a combination of two plain text files, `dsm.opt` and `dsm.sys`.

Before you take a backup using an API, make sure you have the following items fully configured and properly running;

- ▶ A Tivoli Storage Manager server with the appropriate management classes and copy group for DB2 backup
- ▶ A prepared backup environment:
  - A tape library that can mount tapes for a Tape Storage Pool.
  - Enough disk space for a Disk Storage Pool.

### Tivoli Storage Manager client include-exclude option

The include-exclude list is normally configured for the Tivoli Storage Manager Backup-Archive client. It provides the Tivoli Storage Manager Backup-Archive client with the default information about which files to include in a backup and which files to exclude. Another option for this item is to define to which management class each file should be bound.

Example 9-11 shows a sample include-exclude list file. The include-exclude file is read from the bottom to top every time a file is being backed up to the Tivoli Storage Manager server. The management class specified at the line where the file name first fits is used as the backup specification for the file.

*Example 9-11 Include exclude list*

---

```
INCLUDE /.../*  
INCLUDE /SAMPLE/.../* SAMPLE_BACKUP  
INCLUDE /SAMPLE/NODE0000/*.LOG SAMPLE_LOGMGMT  
INCLUDE /SPLITDB/.../* SPLIT_MGMTCLASS
```

---

## 9.4.3 Optional DB2 configurations

After the Tivoli Storage Manager client API is set up, additional configuration can be done using the DB2 database configuration level. There are four database configuration parameters that can override the default Tivoli Storage Manager configuration from the server or client. Their main purpose is to provide an easy way to restore a DB2 database that was backed up to another Tivoli Storage Manager client node.

**Note:** We strongly recommend not using them for normal backup operations, as they overwrite the related API configuration parameters.

The four parameters are:

▶ TSM\_MGMTCLASS

This parameter specifies the management class the DB2 backups should go to. The management class must be in the same Tivoli Storage Manager policy domain where the Tivoli Storage Manager API node is defined.

▶ TSM\_NODENAME

This parameter is used to override the default setting for the node name to make it possible to restore a database that was backed up to Tivoli Storage Manager from another node. The default is that you can only restore a database from Tivoli Storage Manager on the same node from which you took the backup.

▶ TSM\_PASSWORD

This parameter is used to override the default setting for the password associated with the Tivoli Storage Manager.

▶ TSM\_OWNER

This parameter is used to override the default setting for the owner associated with the Tivoli Storage Manager product. The owner name is needed to allow you to restore a database that was backed up to Tivoli Storage Manager from another node.

To set or unset these parameters, use the following command:

```
db2 update db cfg for <dbname> using <parameter-name> value|NULL
```

The complete description of all those parameters can be found in the Tivoli Storage Manager documentation at the following address:

<http://publib.boulder.ibm.com/infocenter/db2luw/v8/index.jsp?topic=/com.ibm.db2.udb.doc/admin/r0000343.htm>

## 9.4.4 Schedule configuration

We use Tivoli Storage Manager scheduling to schedule repeating backup tasks. We define a schedule for a full online backup of the QAS DB2 instance. The schedule is defined centrally on the Tivoli Storage Manager server. The Tivoli Storage Manager client scheduler executes the backup script on the client (desmoines01) on behalf of the Tivoli Storage Manager Server scheduler.

We do not schedule a backup of offline logs, as these are automatically shipped directly to the Tivoli Storage Manager server by DB2 using Tivoli Storage Manager for ERP.

## Schedule configuration on a Tivoli Storage Manager server

To schedule a full online backup, we can use the settings defined in the previous chapter. We should only replace the content of the backup script.

Do these steps:

1. We define a client schedule for a database daily full backup in the FSBACKUPS policy domain, as shown in Example 9-12. The schedule will be triggered within 10 minutes from the defined schedule start (duration=10, duru=min). Schedule SAP\_FULL\_ON will be triggered daily at 11p.m. (start, period, peru). SAP\_FULL\_ON triggers a full online backup of the QAS database by executing the following script at the client node:

```
/tsm/scripts/db2_full_ondb2_full_on.ksh.
```

---

### Example 9-12 Client schedule SAP\_FULL\_ON

---

```
TSM1>define schedule FSBACKUPS SAP_FULL_ON action=command  
object="/tsm/scripts/db2_full_on.ksh" startt=23:00 period=1 peru=day  
duration=10 duru=min
```

---

To activate the execution of the schedule defined in the Tivoli Storage Manager node desmoines01\_fs, we must link the schedule definition in Tivoli Storage Manager server with the Tivoli Storage Manager node. This is achieved by defining a schedule association, as shown in Example 9-13.

---

### Example 9-13 Definition of schedule associations

---

```
TSM1>define association FSBACKUPS SAP_FULL_ON desmoines01_fs
```

---

## Schedule configuration on SAP database server

The following steps must be performed on the SAP database server:

1. To instruct the Tivoli Storage Manager Client Scheduler to authenticate with Tivoli Storage Manager server as node desmoines01\_fs, we must create the profile /usr/tivoli/tsm/client/ba/bin/dsm.opt. This file contains the line SErvername TSM1\_FS. Servername references the appropriate stanza in the dsm.sys file.
2. We adjust the root user's profile by adding Tivoli Storage Manager client variables DSM\_DIR, DSM\_LOG, and DSM\_CONFIG, as shown in Example 9-14 on page 233.

*Example 9-14 Lines added to .profile of the root user*

---

```
export DSM_DIR=/usr/tivoli/tsm/client/ba/bin
export DSM_CONFIG=/usr/tivoli/tsm/client/ba/bin/dsm.opt
export DSM_LOG=/var/log/tsm
```

---

The parameter DSM\_CONFIG instructs Tivoli Storage Manager Client Scheduler to use /usr/tivoli/tsm/client/ba/bin/dsm.op as the default profile. Tivoli Storage Manager Client Scheduler looks for a directory specified by DSM\_DIR for the dsm.sys file. The dsm.sys file in /usr/tivoli/tsm/client/ba/bin is just a symbolic link pointing to /usr/tivoli/tsm/client/api/bin64/dsm.sys.

3. Now we can test the configuration of Tivoli Storage Manager Scheduler by executing **dsmc sched** from the command line, as shown in Example 9-15.

*Example 9-15 The first authentication of the Tivoli Storage Manager Client scheduler*

---

```
# dsmc sched
IBM Tivoli Storage Manager
Command Line Backup/Archive Client Interface
  Client Version 5, Release 5, Level 0.0
  Client date/time: 09/29/08  14:22:14
(c) Copyright by IBM Corporation and other(s) 1990, 2007. All Rights
Reserved.

TSM Backup-Archive Client Version 5, Release 5, Level 0.0
Querying server for next scheduled event.
Node Name: DESMOINES01_FS
Please enter your user id <DESMOINES01_FS>:

Please enter password for user id "DESMOINES01_FS":

Session established with server TSM: AIX-RS/6000
  Server Version 5, Release 5, Level 0.0
  Server date/time: 09/29/08  17:01:18  Last access: 09/29/08
14:21:18

Next operation scheduled:
-----
Schedule Name:      SAP_FULL_ON
Action:            Command
Objects:           /tsm/scripts/db2_full_on.ksh
Options:
Server Window Start: 23:00:00 on 09/29/08
-----
```

Schedule will be refreshed in 7 hours and 9 minutes.

---

4. We modify `/etc/inittab` to start Tivoli Storage Manager Client Scheduler automatically during the AIX startup. The entry is shown in Example 9-16.

*Example 9-16 Startup Tivoli Storage Manager Client Scheduler using `/etc/inittab`*

---

```
tmsched:2345:respawn:/usr/tivoli/tsm/client/ba/bin/dsmc sched
>/dev/null 2>&1
```

---

5. We copy backup scripts to the `/tsm/scripts` directory. The return code of the scripts reflects the result of the backup command `db2 backup db qas`. Tivoli Storage Manager Scheduler considers `RC=0` a successful result. If another value is returned by the scripts, the schedule event is considered as Failed. The `db2_full_on.ksh` script is listed in Example 9-17.

The script includes backup retention control, as the DB2 built-in Tivoli Storage Manager support facility does not automatically control backup retention. The script is designed so that it can be executed from root (Tivoli Storage Manager Client Scheduler is running as root). You must adjust some variables in the script beginning, such as `USER`, `SID`, `KEEP_FULL`.

The retention of backup images is controlled by the parameter `KEEP_FULL`. The script deletes any older backup versions above the number of versions to keep defined by this parameter. It also deletes any offline logs that are older than the oldest full backup image kept in Tivoli Storage Manager.

*Example 9-17 Backup script `db2_full_on.ksh`*

---

```
#!/bin/ksh
MAXRC=0
RC=0
USER=db2qas
SID=QAS
KEEP_FULL=30
. /db2/QAS/sql1lib/db2profile

echo "\n\n ***** Backup full SID: $SID *****"
su - $USER -c "db2 backup db $SID online use tsm without prompting"
RC=$?; [ $RC -gt $MAXRC ] && MAXRC=$RC

if [ $RC -eq 0 ];then
    echo Delete obsolete backup copies, keep $KEEP_FULL versions.
    su - $USER -c "db2adutl delete full keep $KEEP_FULL db $SID without
prompting"
    RC=$?; [ $RC -gt $MAXRC ] && MAXRC=$RC

    # Look for the last valid backup.
```

```

    OLDEST_LOG=`su - $USER -c "db2adutl query full"|grep -p "FULL DATABASE
BACKUP"|grep -v "FULL DATABASE BACKUP"|tail -2|awk '{print $6}'|cut -c2-8`
    if [ `expr $OLDEST_LOG : "[0-9]*" != 7 `]; then
        echo "The logname doesn't have correct format: $OLDEST_LOG"
        return 2
    fi
    OLDEST_LOG=`expr $OLDEST_LOG : "\([0-9]*\) " - 1`
    OLD_LOG=`printf "S%-7.7d" $OLDEST_LOG`

    echo Delete obsolete logs files.
    su - $USER -c "db2adutl delete logs between S0000000.LOG and $OLD_LOG db
$SID without prompting"
    RC=$?;[ $RC -gt $MAXRC ] && MAXRC=$RC
    fi

echo $0 finished with RC=$MAXRC at `date`
return $MAXRC

```

---

## 9.5 Backup and restore using DB2 and the API client

This section shows backup and restore operations for a DB2 environment using the Tivoli Storage Manager API. This section covers the following topics:

- ▶ 9.5.1, “Executing tablespace backup” on page 235
- ▶ 9.5.2, “Executing database backup” on page 236
- ▶ 9.5.3, “Executing restore” on page 236
- ▶ 9.5.4, “Monitoring backup and restore execution on DB2” on page 237
- ▶ 9.5.5, “Finding backup and restore log files or information” on page 238
- ▶ 9.5.6, “Releasing backup tapes” on page 242

### 9.5.1 Executing tablespace backup

When you have to back up one specific tablespace at a time, it may be because the total size of the tablespace requires it, or you have to save data to fall back from a change.

If you have to do this task, you can use our example, where the command to back up tablespace qas#ddici from a database called QAS is **db2 backup db qas tablespace qas#ddici online use tsm**. Example 9-18 shows the result.

*Example 9-18 Backup a tablespace*

---

```
desmoines01:db2qas 8> db2 backup db qas tablespace qas#ddici online use tsm
```

---

Backup successful. The time stamp for this backup image is : 20080917145403

---

For more information about the DB2 **backup** command, go to the following address:

<http://publib.boulder.ibm.com/infocenter/db2luw/v9/index.jsp?topic=/com.ibm.db2.udb.admin.doc/doc/r0001933.htm>

## 9.5.2 Executing database backup

There are two options to back up the entire database: online and offline. We only discuss the online option, as it is the option most commonly used for a production environment. In our example, the command to take the online backup of the database called QAS using Tivoli Storage Manager API is **db2 backup db qas online use tsm**. The result is shown in Example 9-19.

*Example 9-19 Database backup*

---

```
desmoines01:db2qas 9> db2 backup db qas online use tsm
```

---

Backup successful. The time stamp for this backup image is :  
20080917150147

---

## 9.5.3 Executing restore

The **RESTORE DATABASE** command is used to restore backups in order to rebuild a damaged or corrupted database. The command to restore the QAS database using Tivoli Storage manager API is **db2 restore db qas use tsm taken at 20080917150147 INTO qas**.

After the complete restore, apply all the transaction logs, in order to put the database back into the last consistent position, by using the **db2 rollforward db qas stop** command.



For more information about the DB2 **restore** command, go to the following address:

<http://publib.boulder.ibm.com/infocenter/db2luw/v9/index.jsp?topic=/com.ibm.db2.udb.admin.doc/doc/r0001933.htm>

**Note:** The commands we use in this section are listed here as an example. Before you use your own commands, you should have an experienced Database Administrator do an analysis of those commands; you may need to create a duplicate environment to test them.

## 9.5.4 Monitoring backup and restore execution on DB2

This section describes how to monitor the current backup and restore execution. There are many ways to do this task. Here are the most common procedures used in the daily SAP administrator task.

You can monitor the backup execution from the DB2 Command Line Processor. Use the **db2 list utilities** command to list all the utilities that are currently in action. The result is shown in Example 9-20.

*Example 9-20 List of utilities execution*

---

```
desmoines01:db2qas 6> db2 list utilities

ID                = 5
Type              = BACKUP
Database Name     = QAS
Partition Number = 0
Description       = online db
Start Time        = 09/17/2008 15:01:47.897730
State             = Executing
Invocation Type   = User
Throttling:
  Priority         = Unthrottled
Progress Monitoring:
  Estimated Percentage Complete = 30
```

---

You can monitor the backup progress by looking at the Estimated Percentage Complete field. Also, you can run the **query session** command in the Tivoli Storage Manager console to see if the connection from the DB2 client and the Tivoli Storage Manager server has succeeded. The result is shown in Example 9-21.

*Example 9-21 Session list*

```
sm: TSM>q ses
```

---

Sess Number	Comm. Method	Sess State	Wait Time	Bytes Sent	Bytes Recvd	Sess Type	Platform	Client Name
1,314	Tcp/Ip	Run	0 S	79.7 K	1.5 K	Admin	AIX	ADMIN
1,320	Tcp/Ip	RecvW	0 S	1.6 K	66.5 M	Node	DB2/AIX 64	DESMOINES01_API

---

## 9.5.5 Finding backup and restore log files or information

In this section, we cover the following topics:

- ▶ “Listing backup history from DB2” on page 238
- ▶ “Listing backup reports using db2adutl tool” on page 240
- ▶ “Listing backups from the Tivoli Storage Manager console” on page 241
- ▶ “Listing backups from DB2 tables” on page 241

### Listing backup history from DB2

You can list the complete backup history of the specific database from the DB2 Command Line Processor. To get the complete list of the database archive log backup, you can use the **db2 list history archive log all** command. To list the complete backup history for the database called QAS, run **db2 list history backup all for db QAS**. The result is shown in Example 9-22.

*Example 9-22 Backup history listing*

---

```
desmoines01:db2qas 20> db2 LIST HISTORY BACKUP ALL FOR DB QAS
```

List History File for QAS

Number of matching file entries = 73

```
Op Obj Timestamp+Sequence Type Dev Earliest Log Current Log Backup ID
-----
```

B	D	20080808185040001	F	D	S0000000.LOG	S0000000.LOG	
---	---	-------------------	---	---	--------------	--------------	--

---

Contains 34 tablespace(s):

00001 SYSCATSPACE  
00002 SYSTOOLSPACE  
00003 QAS#DBD  
00004 QAS#DBI  
00005 QAS#FACTD  
00006 QAS#FACTI  
00007 QAS#EL700D  
00008 QAS#EL700I  
00009 QAS#CLUD  
00010 QAS#CLUI  
00011 QAS#LOADD  
00012 QAS#LOADI  
00013 QAS#SOURCED  
00014 QAS#SOURCEI  
00015 QAS#USERID  
00016 QAS#USERII  
00017 QAS#ES700D  
00018 QAS#ES700I  
00019 QAS#PROTD  
00020 QAS#PROTI  
00021 QAS#ODSD  
00022 QAS#ODSI  
00023 QAS#DOCUD  
00024 QAS#DOCUI  
00025 QAS#STABD  
00026 QAS#STABI  
00027 QAS#BTABD  
00028 QAS#BTABI  
00029 QAS#POOLD  
00030 QAS#POOLI  
00031 QAS#DIMD  
00032 QAS#DIMI  
00033 QAS#DDICD  
00034 QAS#DDICI

---

More information about the **db2 list history** command can be found at the following address:

<http://publib.boulder.ibm.com/infocenter/db2luw/v9/index.jsp?topic=/com.ibm.db2.udb.admin.doc/doc/r0001991.htm>

## Listing backup reports using db2adutl tool

The **db2adutl** command is an Tivoli Storage Manager tool that specifically manages DB2 database backups. It provides facilities to query, extract, verify, and delete backup images done by Tivoli Storage Manager API. You can find more information about this DB2 tool at the following address:

<http://publib.boulder.ibm.com/infocenter/db2luw/v8/index.jsp?topic=/com.ibm.db2.udb.doc/core/r0002077.htm>

To get a report about all the available backups taken by DB2 using the Tivoli Storage Manager API, run **db2adutl query**. The result is shown in Example 9-23.

*Example 9-23 Listing the DB2 backup history for QAS database*

---

```
desmoines01:db2qas 30> db2adutl query
```

```
Query for database QAS
```

```
Retrieving FULL DATABASE BACKUP information.
```

```
  1 Time: 20080917150147  Oldest log: S0000001.LOG  DB Partition  
Number: 0  Sessions: 1
```

```
Retrieving INCREMENTAL DATABASE BACKUP information.
```

```
No INCREMENTAL DATABASE BACKUP images found for QAS
```

```
Retrieving DELTA DATABASE BACKUP information.
```

```
No DELTA DATABASE BACKUP images found for QAS
```

```
Retrieving TABLESPACE BACKUP information.
```

```
No TABLESPACE BACKUP images found for QAS
```

```
Retrieving INCREMENTAL TABLESPACE BACKUP information.
```

```
No INCREMENTAL TABLESPACE BACKUP images found for QAS
```

```
Retrieving DELTA TABLESPACE BACKUP information.
```

```
No DELTA TABLESPACE BACKUP images found for QAS
```

```
Retrieving LOAD COPY information.
```

```
No LOAD COPY images found for QAS
```

Retrieving LOG ARCHIVE information.  
No LOG ARCHIVE images found for QAS

---

To list all the archivelog backups using **db2adut1**, run the **db2adut1 query full archivelog** command.

### Listing backups from the Tivoli Storage Manager console

You can list all backups done by the DB2 backup command from the Tivoli Storage Manager catalog. Use the **select** command to list the backups from an specific file space, for example, **select NODE\_NAME, FILESPACE\_NAME, LL\_NAME, BACKUP\_DATE from backups where FILESPACE\_NAME='/QAS'**. The result is shown in Example 9-24.

#### Example 9-24 Listing a DB2 backup in the Tivoli Storage Manager console

---

```
tsm: TSM>select NODE_NAME, FILESPACE_NAME, LL_NAME, BACKUP_DATE from backups where  
FILESPACE_NAME='/QAS'
```

ANR2963W This SQL query may produce a very large result table, or may require a significant amount of time to compute.

Do you wish to proceed? (Yes (Y)/No (N)) y

NODE_NAME	FILESPACE_NAME	LL_NAME	BACKUP_DATE
DESMOINES01_API	/QAS	FULL_BACKUP.20080- 917150147.1	2008-09-17 15:01:17.000000

---

### Listing backups from DB2 tables

The information you can get from running the **db2 list history** command can also be obtained from the DB2 table `sysibmadm.db_history`, which is available in DB2 Version 9 and later. (However, we strongly suggest that you use the DB2 command.) This method is mostly used when you are required to process the information (using your own tools) or create an customized report.

Example 9-25 shows the **select** command that lists all the backups of the DB2 instance called QAS.

*Example 9-25 Sample SQL command to extract backup information from DB2 table*

```
db2 => select start_time, end_time , substr(comment,1,30) FROM
SYSIBMADM.DB_HISTORY WHERE OPERATION = 'B' AND OPERATIONTYPE = 'F'
```

START_TIME	END_TIME	3
20080808185040	20080808190533	DB2 BACKUP QAS OFFLINE
20080903155506	20080903160133	DB2 BACKUP QAS OFFLINE
20080916170618	20080916171958	DB2 BACKUP QAS OFFLINE
20080917101256	20080917101327	DB2 BACKUP QAS OFFLINE
20080917132110	20080917132111	DB2 BACKUP QAS OFFLINE
20080917143131	20080917143132	DB2 BACKUP QAS OFFLINE
20080917143647	20080917143648	DB2 BACKUP QAS OFFLINE
20080919103555	20080919103557	DB2 BACKUP QAS OFFLINE
20080919112156	20080919113723	DB2 BACKUP QAS OFFLINE
20080925163934	20080925163935	DB2 BACKUP QAS OFFLINE

10 record(s) selected.

More information about the `sysibmadm.db_history` table can be found at the following address:

<http://publib.boulder.ibm.com/infocenter/db2luw/v9/index.jsp?topic=/com.ibm.db2.udb.admin.doc/doc/r0022351.htm>

## 9.5.6 Releasing backup tapes

One of the most important task in backup management is to release backup tapes in order to recycle tapes and to avoid keeping backups indefinitely.

To delete one backup taken by a DB2 command using Tivoli Storage Manager, use the **db2adutl delete full taken at 20080917150147 db QAS** command. The results are shown in Example 9-26.

*Example 9-26 Releasing DB2 backup*

```
desmoines01:db2qas 30> db2adutl delete full taken at 20080917150147 db
QAS
Query for database RAWAMPL
Retrieving FULL DATABASE BACKUP information.
Taken at: 20080917150147 DB Partition Number: 0 Sessions: 1
```

Do you want to delete this file (Y/N)? y

Are you sure (Y/N)? y

Retrieving INCREMENTAL DATABASE BACKUP information.  
No INCREMENTAL DATABASE BACKUP images found for QAS

Retrieving DELTA DATABASE BACKUP information.  
No DELTA DATABASE BACKUP images found for QAS

---

In addition you can use the following commands:

- ▶ Releasing DB2 online backups: **db2adut1 delete keep <NR> or db2adut1 delete older than <NR> database <database name>**
- ▶ Releasing DB2 transaction log backups: **db2 PRUNE LOGFILE PRIOR TO <archive\_name>**

## 9.6 Tivoli Storage Manager for ERP-DB2 installation

The installation packages are located on the Data Protection for SAP CD-ROMs. Images of the CD-ROMs can be downloaded from Passport Advantage® at the following address:

<http://www-01.ibm.com/software/howtobuy/passportadvantage/>

Initial installations must always be done from the CD-ROM or image, as it contains the license file. Refer to the file README.1ST in the root path for information about where to find documents on the CD or image, and follow the appropriate installation description.

If you are going to upgrade from an earlier version of Tivoli Storage Manager for ERP in your environment, you have the option to either upgrade from the product CD-ROM or image, or to download the latest version from the IBM public FTP server. For more information about this topic, go to the following address:

<http://www.ibm.com/software/sysmgmt/products/support/IBMTivoliStorageManagerforEnterpriseResourcePlanning.html>

The topics discussed here are:

- ▶ 9.6.1, “Required information for Data Protection for SAP” on page 244
- ▶ 9.6.2, “Installing Tivoli Storage Manager for ERP” on page 244
- ▶ 9.6.3, “System changes after Tivoli Data Protection for SAP installation” on page 246

## 9.6.1 Required information for Data Protection for SAP

You must obtain the following information before starting the installation procedure:

- ▶ DB2 database SID.
- ▶ Tivoli Storage Manager server name or IP address.
- ▶ Tivoli Storage Manager node name: The Tivoli Storage Manager node is configured on the Tivoli Storage Manager server.
- ▶ Tivoli Storage Manager management classes for database and log file backups.
- ▶ Path where the Tivoli Storage Manager API resides, which is the content of environment variable `DSMI_DIR`. The default is `/usr/tivoli/tsm/client/api/bin64`.
- ▶ Path to the client option file of Tivoli Storage Manager, which is the content of environment variable `DSMI_CONFIG`.
- ▶ Path to Tivoli Storage Manager log files, which is the content of environment variable `DSMI_LOG`. The Tivoli Storage Manager API will create the file `dsierror.log` in this path. The default is in `/usr/tivoli/tsm/client/api/bin64/dsmerror.log`.
- ▶ Installation path for Data Protection for SAP executables. The default is `/usr/tivoli/tsm/tdp_r3/db264`.

## 9.6.2 Installing Tivoli Storage Manager for ERP

Tivoli Storage Manager for ERP is delivered as a single executable file for all supported platforms. These installation packages are provided on a CD or CD image. The packages are named as follows:

- ▶ For a CD image, the file is called `<version>-TIV-TSMERPDB2-<platform>`.
- ▶ Packages on the FTP server have the FTP prefix prior to the platform designation.

The package files have an extension appropriate to the platform and are executable. When you invoke the file, you will be guided through the Tivoli Storage Manager for ERP setup procedure. The default path for the Tivoli Storage Manager for ERP installation on AIX is `/usr/tivoli/tsm/tdp_r3`.

For the purposes of this case study we use the following installation parameters:

- ▶ Oracle SID: QAS
- ▶ The location of SAP configuration file: `/db2/QAS/tdp_r3`
- ▶ DSM.SYS stanza: `TSM1_TDP_DB2`



- ▶ Tivoli Storage Manager node name: DESMOINES01\_TDP
- ▶ Backup management class: DBBACKUPS
- ▶ Archive management class: LOGS

We perform the following steps to install Tivoli Storage Manager for ERP (DB2):

1. Log on as the root user to server desmoines01.
2. Install the Tivoli Storage Manager API Client on desmoines01.
3. Invoke the installation file for Tivoli Storage Manager for ERP (DB2) for AIX using the **5.5.0.0-TIV-TSMERPDB2-AIX64.bin -console** command. The `-console` parameter gives us a text-based interface instead of the Java GUI. The installation process is shown in Example 9-27.

*Example 9-27 Example of Tivoli Storage Manager for ERP - DB2 installation process*

---

Please enter the required information

Enter DB2 UDB database SID (max. 6 characters)  **QAS**

Press 1 for Next, 2 for Previous, 3 to Cancel or 5 to Redisplay [1] **1**

-----  
Please enter the required information

Enter directory for Data Protection for SAP (DB2) configuration files  
(only directories without blanks are valid) [/db2/QAS/dbs]  
**/db2/QAS/tdp\_r3**

Press 1 for Next, 2 for Previous, 3 to Cancel or 5 to Redisplay [1] **1**

-----  
To connect to the TSM server with basic settings the installer updates  
the configuration files with the provided parameters. If you don't want  
the parameters updated answer the next question with NO.

1 - Yes (recommended for first time installation)

2 - No (recommended for update installation)

To select an item enter its number, or 0 when you are finished [0]: **0**

Enter TSM server. The name must already exist in dsm.sys.

**TSM1\_TDP\_DB2**

Enter TSM node name  **desmoines01\_tdp**

Enter management class for database backups  **dbbackups**

Enter management class(es) for log file backups  **logs**

Press 1 for Next, 2 for Previous, 3 to Cancel or 5 to Redisplay [1] **1**

-----  
To enable Data Protection for SAP (DB2) to connect to the Administration Assistant Server the following information is needed. If you don't specify a server, the connection will be disabled.

Enter network address of Administration Assistant Server [ ] **desmoines01**  
Enter port for Administration Assistant Server [ **5126** ]

Press 1 for Next, 2 for Previous, 3 to Cancel or 5 to Redisplay [1] **1**  
-----

Data Protection for SAP (DB2) will be installed in the following location: /usr/tivoli/tsm/tdp\_r3/db264  
-----

### 9.6.3 System changes after Tivoli Data Protection for SAP installation

The following system modifications are performed by the installation:

- ▶ An entry is created in /etc/inittab to start the ProLE daemon automatically.
- ▶ An entry is created in /etc/services for the service tdpr3db2 or tdpr3db264.
- ▶ The environment variable DB2\_VENDOR\_LIB points to the fully qualified path where the shared library of Data Protection for SAP resides.
- ▶ The environment variable XINT\_PROFILE points to the Data Protection for SAP profile located in the path for configuration files specified during installation. The file name is init<SID>.ut1, where <SID> is the DB2 database SID specified during installation.
- ▶ The environment variable TDP\_DIR points to the path where Data Protection for SAP saves its configuration files and creates its own process logs. Initially, this path is set to <profile path>/tdplog, where <profile path> is the path for Tivoli Data Protection for SAP profile specified during installation.

With DB2 V8.2 or higher, if a DB2 instance is running, the DB2 configuration will be updated automatically. The configuration changes are for:

- ▶ The VENDOROPT parameter in the DB2 configuration to the Tivoli Data Protection for SAP vendor environment file.
- ▶ LOGARCHMETHn and LOGARCHOPTn are set, if requested. The installation sets the following values:

```
LOGARCHMETHn    VENDOR: /<path>/<library>  
LOGARCHOPTn    /<path>/vendor.env
```

**Note:** If the DB2 instance has not been started prior to Tivoli Data Protection installation, the above actions have no effect and must be performed manually at a later time (as discussed in 9.7.3, “Manual configuration alternative” on page 251); otherwise, backups will fail.

## 9.7 Tivoli Storage Manager for ERP configuration

The integration of DB2 with Tivoli Storage Manager for ERP is done through the vendor API adaptor installed as a part of Tivoli Storage Manager for ERP. DB2 can use Tivoli Storage Manager for ERP for database and offline logs backup when VENDOR API is configured as an interface. The activities are:

- ▶ 9.7.1, “Configuration on the Tivoli Storage Manager server” on page 247
- ▶ 9.7.2, “Data protection configuration on SAP server” on page 248
- ▶ 9.7.3, “Manual configuration alternative” on page 251
- ▶ 9.7.4, “Automation options of Data Protection for SAP” on page 254
- ▶ 9.7.5, “Schedule configuration” on page 255

### 9.7.1 Configuration on the Tivoli Storage Manager server

We perform the following steps on the Tivoli Storage Manager server:

1. We define policy domain DATABASE\_TDP with two management classes for the backup of data files (DBBACKUPS) and for the backup of redo log files (LOGS).
2. We also define an archive copy group within each of the management classes. The backup retention control will be performed by Tivoli Storage Manager for ERP. Therefore, we define archive copy groups for each management class with the parameter RETVER=nolimit.
3. For the archive copy group in the DBBACKUPS management class, the destination storage pool, BACKUPTAPE, is of device type TAPE. For the archive copy group in the LOGS management class, the destination storage pool, BACKUPDISK, is of device type DISK. The storage pool BACKUPTAPE is the next storage pool for storage pool BACKUPDISK in the storage hierarchy. Therefore, data from BACKUPDISK automatically migrates to BACKUPTAPE.

4. We register the Tivoli Storage Manager node with the DATABASE\_TDP policy domain and set the parameters for the Tivoli Storage Manager node, as shown in Example 9-28.

*Example 9-28 Tivoli Storage Manager node registration*

---

```
TSM1>reg node desmoines01_tdp passw0rd doma=DATABASE_TDP maxnummp=2
```

---

## 9.7.2 Data protection configuration on SAP server

The following steps must be performed on the SAP database server:

1. Before installing Tivoli Storage Manager for ERP, we define server stanzas in the `dsm.sys` file, which is the configuration profile of Tivoli Storage Manager API Client. We define two server stanzas: `TSM1_TDP_DB2` and `TSM1_FS`, as shown in Example 9-29. `TSM1_TDP_DB2` is used for the DB2 online backup and `TSM1_FS` is used for the file system backup.

The parameter `PASSWORDACCESS` set to `generate` allows Backup Archive Client and Tivoli Storage Manager Client Scheduler to store the password locally after initial invocation. This allows the processes to run from `/etc/inittab`.

*Example 9-29 /usr/tivoli/tsm/client/api/bin64/dsm.sys*

---

```
SErvername TSM1_FS  
COMMethod      TCPip  
TCPPort        1500  
TCPServeraddress lincoln02  
passwordaccess   generate  
nodename         desmoines01_fs
```

```
SErvername TSM1_TDP_DB2  
COMMethod      TCPip  
TCPPort        1500  
TCPServeraddress lincoln02  
passwordaccess   prompt  
enablelanfree   yes
```

---

2. We decide to use the same `dsm.sys` profile file for Tivoli Storage Manager Backup Archive Client and for Tivoli Storage Manager for ERP. Therefore, we created a symbolic link `dsm.sys` in the Tivoli Storage Manager Backup Archive installation directory pointing to `dsm.sys` in the Tivoli Storage Manager API directory, as shown in Example 9-3 on page 226.

*Example 9-30 Create link to dsm.sys file*

---

```
ln -s /usr/tivoli/tsm/client/api/bin64/dsm.sys
/usr/tivoli/tsm/client/ba/bin/dsm.sys
```

---

3. We adjust the db2qas user's profile by adding the Tivoli Storage Manager API variables DSMI\_DIR and DSMI\_LOG to the .cshrc\_profile file, as shown in Example 9-31.

*Example 9-31 Lines added to .cshrc profile of the db2qas user*

---

```
setenv DSMI_DIR /usr/tivoli/tsm/client/api/bin64
setenv DSMI_LOG /var/log/tsm
```

---

4. We create an error log directory in /var/log/tsm. We adjust the access rights that enable the db2qas user to perform read and write operations to the log directory using the **chmod ugo+rw /var/log/tsm** command.
5. The Tivoli Storage Manager for ERP installation procedure creates the profile `initQAS.utl` in the `/db2/QAS/dbs` directory. The contents of this directory are shown in Example 9-32.

*Example 9-32 /db2/QAS/dbs/initQAS.utl*

---

```
BACKUPIDPREFIX      QAS___
MAX_SESSIONS        1
BUFFSIZE            131072
MAX_VERSIONS        30
CONFIG_FILE          /db2/QAS/tdp_r3/initQAS.bki
SERVER               tsm1_tdp_db2
SESSIONS            2
PASSWORDREQUIRED    YES
ADSMNODE             desmoines01_tdp
BRBACKUPMGTCLASS    DBBACKUPS
BRARCHIVEMGTCLASS   LOGS
END
```

---

The `initQAS.utl` in Example 9-32 contains the node name, management classes, and server stanzas reference from `dsm.sys` (`tsm1_tdp_db2`). The versioning on the Tivoli Storage Manager server is using `RETVER=NOLIMIT`. Tivoli Storage Manager for ERP performs the expiration of the obsolete backup versions by specifying the `MAX_VERSIONS` parameter. We use 30 versions to match the backup requirement from Table 9-1 on page 216.

The `MAX_VERSIONS` parameter defines the maximum number of database backup versions to be kept in backup storage. Every time a full backup completes successfully, the version count is incremented by 1 and stored in the Tivoli Data Protection for SAP configuration file. This value is also

assigned to the tablespace files and to all subsequent DB2 log file backups. If the number of versions kept in backup storage is larger than the specified maximum number of backup versions (stored in the parameter `MAX_VERSIONS`), the oldest version is deleted, together with the corresponding tablespace and incremental and log file backups until only the specified maximum number of the most recent versions remain. For partitioned DB2 databases, backup version control is done on a partition basis. Therefore, full backups should always be initiated for all partitions at the same time.

- Partial backups get the same version number as the last successful full backup. When Tivoli Data Protection for SAP deletes an old full backup, all partial backups with the same version number are also deleted.
  - Every database instance needs its own configuration file (see parameter `CONFIG_FILE`) and a unique `BACKUPIDPREFIX`.
  - Every database partition needs its own configuration file. Partitions of a partitioned database should have the same `BACKUPIDPREFIX`.
6. We switch from root to `db2qas` to update the locally stored password for Tivoli Storage Manager node `desmoines_tdp` using the `backom` command, as shown in Example 9-33.

Tivoli Data Protection for SAP should be installed after the Tivoli Storage Manager installation has been completed. Tivoli Data Protection for SAP must use the same password access method as specified within Tivoli Storage Manager. When Tivoli Data Protection for SAP is installed, it is assumed that the password method selected during the Tivoli Storage Manager installation was manual password handling (`PASSWORDACCESS` prompt). The default parameters for Tivoli Data Protection for SAP are set according to this assumption. If a different password method is set within Tivoli Storage Manager, adjust the Tivoli Data Protection for SAP parameters accordingly.

To be able to work with Tivoli Data Protection for SAP, you have to provide Tivoli Data Protection for SAP with the password for the Tivoli Storage Manager node. You can use the `backom -c password` command to set the password.

*Example 9-33 Update the Tivoli Storage Manager node password*

---

```
#su - db2qas
desmoines01:db2qas 1>/usr/tivoli/tsm/tdp_r3/db264/backom -c password
```

---

7. There are two ways of creating the configuration file (`*.bki`):
- When setting the Tivoli Storage Manager password with the `backom` utility, the configuration files for all DB2 partitions are created automatically in the path `<path>/<db2node>/`, where `<path>` is the directory denoted by the value of keyword `CONFIG_FILE` in the profile and `<DB2NODE>` is

replaced automatically by a DB2 partition name referenced in the DB2 configuration file `db2node.cfg`. If the database is not partitioned, `NODE0000` is used as the only DB2 partition name.

- You can manually create the required paths. For each database partition, create the directory `<path>/<db2node>/`. The naming convention for a name to be built from the node (partition) number is a string starting with 'NODE' followed by a four digit partition number. Copy the existing file `init<SID>.bki` into each of these paths.
8. We set DB2 Log Manager to use the vendor API library provided by Tivoli Storage Manager for ERP for automatic backup of offline log files. This is adjusted as shown in Example 9-34. We discuss more about this topic in “Built-in log manager setup” on page 252.

*Example 9-34 DB2 Log Manager changes for Tivoli Storage Manager for ERP*

---

```
#su - db2qas
desmoines01:db2qas 1>db2 update db cfg for QAS using LOGARCHMETH1
VENDOR:/usr/tivoli/tsm/tdp_r3/db264/libtdpdb2.a
desmoines01:db2qas 1>db2 update db cfg for QAS using LOGARCHOPT1
/db2/QAS/tdp_r3/vendor.env
desmoines01:db2qas 1>db2 update db cfg for QAS using FAILARCHPATH
/db2/QAS/log_archive
```

---

9. Restarting DB2 Instance (optional).

If your DB2 installation is older than DB2 Version 8.2 or 8.1 Fix Pack 7, then you must restart DB2 to pick up the option files and environment variable changes. Otherwise, you must specify all parameters in the `OPTIONS` parameter of the `BACKUP DATABASE` or `RESTORE DATABASE` commands.

### 9.7.3 Manual configuration alternative

There are several post installation steps that must be performed. They are:

- ▶ “Setting the vendor parameter” on page 251
- ▶ “Built-in log manager setup” on page 252

#### Setting the vendor parameter

Use these manual steps only if a DB2 instance was not running at the time of your installation. Set the values for `VENDOROPT` by running this command:

```
db cfg for <SID> using VENDOROPT <value>
```

The VENDOROPT configuration must refer to the fully qualified path of the file containing Data Protection for SAP environment settings for DB2. Make sure that the environment settings of your system match the settings in this file. This command can be used as an alternative to the **db2set** command. Its advantages are:

- ▶ There is no need to restart the DB2 instance.
- ▶ You can define the default values for the OPTIONS parameter of the BACKUP DATABASE and RESTORE DATABASE commands in the DB2 configuration.
- ▶ The same settings apply to database backup and restore and log file archive and retrieve.

**Note:** When using the BACKUP DATABASE and RESTORE DATABASE commands with the USE SNAPSHOT option for snapshot-based backup and restore by DB2 Advanced Copy Services, the VENDOROPT parameter is currently not examined. In this case, any options other than the default values must be set using the OPTIONS keyword.

### Built-in log manager setup

If you want to activate log archiving and retrieving with the DB2 Log Manager facility included with DB2 Version 8.2, the database configuration of the SAP database has to be adapted. This is offered as an installation option.

The database configuration parameters in Table 9-4 were introduced in DB2 V8.2.

*Table 9-4 Database configuration parameters for log management*

Parameter	Description	Default
LOGARCHMETH1	Media type of the primary destination for archived log files.	Off
LOGARCHOPT1	Options field for the primary destination for archived log files (if required).	NULL
LOGARCHMETH2	Media type of the secondary destination for archived log files. If this path is specified, log files will be archived to both this destination and the destination specified by LOGARCHMETH1.	Off
LOGARCHOPT2	Options field for the secondary destination for archived log files (if required).	NULL
FAILARCHPATH	If DB2 is unable to archive log files to both the primary and secondary (if set) archive destinations due to a media problem, then DB2 will try to archive log files to this path. This path must be a disk.	NULL



Parameter	Description	Default
NUMARCHRETRY	Number of retries to archive a log file to the primary or secondary archive destination before trying to archive log files to a failover directory. This is only used if FAILARCHPATH is set. If NUMARCHRETRY is not set, DB2 will continuously retry archiving to the primary or secondary log archive destination.	5
ARCHRETRYDELAY	Number of seconds to wait after a failed archive attempt before trying to archive the log file again. Subsequent retries will only take effect if NUMARCHRETRY is at least set to 1.	2
VENDOROPT	For Tivoli Data Protection for SAP, specification of a file containing additional parameters that DB2 may need to use to communicate with (vendor) storage systems during backup, restore, archive or retrieve operations. These options are then made available as environment variables.	NULL

Thus, you must at least set LOGARCHMETH1 and LOGARCHOPT1. The changes are invoked within the DB2 command environment as follows:

► For UNIX and Linux:

```
update db cfg for <SID> using LOGARCHMETH1
VENDOR:/<path>/libtdpdb2.a
update db cfg for <SID> using LOGARCHOPT1 /<path>/vendor.env
```

► For Windows:

```
update db cfg for <SID> using LOGARCHMETH1 VENDOR:<path>\tdpdb2.dll
update db cfg for <SID> using LOGARCHOPT1 <path>\vendor.env
```

When updating the LOGARCHMETH database configuration parameters, the change will take effect on the next log file to be archived.

The former database configuration parameters USEREXIT and LOGRETAIN are integrated into the LOGARCHMETH configuration parameters. During migration to DB2 Version 8.2 (or when updating to DB2 Version 8.1 FP7, which corresponds to DB2 Version 8.2), LOGARCHMETH1 will be set to USEREXIT if the database is using that parameter. All of the other database configuration parameters are defined with their default values. This means that the old Userexit executable provided with the SAP-DB2 Administration Tools package should still be available to the database until the database administrator decides to change these settings.

**Note:** Remember to set up the number of Tivoli Storage Manager sessions used by Tivoli Data Protection for SAP properly. Typically, during online database backups, log archives will be initiated. Thus, configure Tivoli Data Protection for SAP in such a way that at least one Tivoli Storage Manager session, one for the database backup and one for the log archives, is available for each of these operations.

## 9.7.4 Automation options of Data Protection for SAP

Data Protection for SAP comes with a variety of options that can help improve your administrative productivity:

- ▶ “Selectable management classes” on page 254
- ▶ “Multiple redo log copies” on page 255
- ▶ “Alternate network paths and servers” on page 255
- ▶ “Messaging” on page 255
- ▶ “Front-end and back-end processing” on page 255

### Selectable management classes

You can specify different Tivoli Storage Manager management classes for backing up and archiving data. It is a best practice to configure Data Protection for SAP to back up directly into a tape storage pool and to archive log files into a disk storage pool. In addition, multiple management classes have to be used in conjunction with multiple redo log copies.

The definitions for the configuration files (.ut1) are:

- ▶ BRARCHIVEMGTCLASS management\_class [management\_class...]  
Specifies the Tivoli Storage Manager management class(es) Tivoli Data Protection for SAP uses when called from BRARCHIVE. Each parameter string can consist of up to 30 characters. Specify a separate BRARCHIVEMGTCLASS for each log file copy requested. Therefore, the number of different BRARCHIVE management classes specified must be greater than or equal to the number of redo log copies (keyword REDOLOG\_COPIES).
- ▶ BRBACKUPMGTCLASS management\_class [management\_class...]  
Specifies the Tivoli Storage Manager management class(es) Tivoli Data Protection for SAP uses when called using BRBACKUP. The parameter string can consist of up to 30 characters. This must be defined in conjunction with the respective SERVER statement.

- ▶ REDOLOG\_COPIES n|1

Specifies the number of copies Tivoli Data Protection for SAP stores for each processed Oracle redo log. The valid range is from 1 to 9. If not specified, Tivoli Data Protection for SAP stores one copy of the redo logs. The number of different BRARCHIVE management classes (keyword BRARCHIVEMGTCLASS) specified must be greater than or equal to the number of log file copies specified.

### **Multiple redo log copies**

As protection against tape defects and to improve availability and disaster recovery, you can back up multiple copies of a log file and configure your system such that these copies are located on different physical Tivoli Storage Manager volumes or even different Tivoli Storage Manager servers. If at restore time one log file copy is unavailable, Data Protection for SAP automatically switches to another copy and continues restoring from the log file from that copy.

### **Alternate network paths and servers**

Similar to the configuration of multiple network paths and servers, you can configure Data Protection for SAP to use multiple Tivoli Storage Manager servers or multiple network connections to one Tivoli Storage Manager server to improve availability of backup storage. In such a configuration, Data Protection for SAP checks all servers and network connections for availability and allows you to perform your backups even if some resources are currently unavailable. Also, you can establish policies to use different Tivoli Storage Manager servers at different days of the week

### **Messaging**

You can establish policies that trigger Data Protection for SAP to send different classes of log messages to a Tivoli Storage Manager server.

### **Front-end and back-end processing**

Data Protection for SAP allows you to register applications that are executed before starting a backup and restore operation and after it has completed.

## **9.7.5 Schedule configuration**

This section discusses schedule configuration:

- ▶ “Schedule configuration on Tivoli Storage Manager server” on page 256
- ▶ “Schedule configuration on SAP server” on page 256

## Schedule configuration on Tivoli Storage Manager server

On the Tivoli Storage Manager server, you can use the Tivoli Storage Manager Server Scheduler configuration steps described in “Schedule configuration on a Tivoli Storage Manager server” on page 232.

## Schedule configuration on SAP server

On the SAP server, you can use the Tivoli Storage Manager Client Scheduler configuration steps described in “Schedule configuration on SAP database server” on page 232. However, you must use a different backup script that calls Backup Object Manager command **backom** instead of the **db2 backup** command. The modified script is shown in Example 9-35.

*Example 9-35 Script db2\_full\_on.ksh for Tivoli Storage Manager for ERP*

---

```
#!/usr/bin/ksh
MAXRC=0
SID=QAS
sid=qas
echo "\n\n Database $SID online backup..."
su - db2${sid} <<EOB
    /usr/tivoli/tsm/tdp_r3/db264/backom -c b_db -a $SID -R full -0
EOB

MAXRC=$?
return $MAXRC
```

---

## 9.8 Backup and restore using Data Protection for SAP

This section shows some examples of backup and restore options for DB2 environment using Tivoli Data Protection for SAP:

- ▶ 9.8.1, “Executing backup” on page 256
- ▶ 9.8.2, “Executing restore” on page 257
- ▶ 9.8.3, “Backup and restore for DB2 partitions” on page 257
- ▶ 9.8.4, “Monitoring backup and restore execution” on page 258
- ▶ 9.8.5, “Getting reports from backup” on page 259
- ▶ 9.8.6, “Releasing tapes and backup expiration” on page 262

### 9.8.1 Executing backup

To take a full online backup for a database called QAS, run **backom -c b\_db -a QAS -0**. The result is shown in Example 9-36 on page 257.

*Example 9-36 Online backup with backom*

```
desmoines01:db2qas 26> backom -c b_db -a QAS -0
```

```
=====
Data Protection for SAP(R) - Backup Object Manager

- Version 5, Release 5, Modification 0 Level 2 for AIX LF 64-bit -
  Build: 316L compiled on Jun 19 2008
(c) Copyright IBM Corporation, 1996, 2008, All Rights Reserved.
=====

BKI8637I: Full online backup of 'QAS' started ...
```

The complete syntax of **backom** backup command can be found at the following address:

<http://publib.boulder.ibm.com/infocenter/tivihelp/v1r1/index.jsp?topic=/com.ibm.itsmerp.doc/fbrd000050.htm>

## 9.8.2 Executing restore

To restore the latest online backup from a database called QAS taken by Data Protection for SAP for DB2, run **backom -c r\_db -a QAS**.

**Note:** This command is an example. The decision to restore the entire database should be decided upon by an experienced Database Administrator. There are many items to check before you can decide to do a restore.

The complete syntax of the **backom** restore command can be found at the following address:

<http://publib.boulder.ibm.com/infocenter/tivihelp/v1r1/index.jsp?topic=/com.ibm.itsmerp.doc/fbrd000050.htm>

## 9.8.3 Backup and restore for DB2 partitions

For a DB2 partitioned database, you have a different way to perform backups. Data Protection for SAP uses the DB2 command **db2\_a11** for separation and parallelization of the backup and restore commands. The **db2\_a11** command provides special characters for handling partitions and for running commands in parallel or sequentially.

You can find complete information about backing up DB2 Partitions with this command at the following address:

<http://publib.boulder.ibm.com/infocenter/db2luw/v9/index.jsp?topic=/com.ibm.db2.udb.admin.doc/doc/c0005945.htm>

## 9.8.4 Monitoring backup and restore execution

This section describes how to monitor the current backup and restore execution. There are many ways to do this task. Here we discuss the most common procedures used in the daily SAP administrator task.

You can monitor the backup execution from a DB2 Command Line Processor. Use the command **db2 list utilities** to list all utilities that are currently in execution. The result is shown in Example 9-37.

### *Example 9-37 List of utilities execution*

---

```
desmoines01:db2qas 6> db2 list utilities

ID                               = 5
Type                             = BACKUP
Database Name                     = QAS
Partition Number                  = 0
Description                       = online db
Start Time                       = 09/17/2008 15:01:47.897730
State                             = Executing
Invocation Type                   = User
Throttling:
  Priority                         = Unthrottled
Progress Monitoring:
  Estimated Percentage Complete = 30
```

---

You can monitor the backup's progress by looking at the Estimated Percentage Complete field, as shown in Example 9-37. You can check if the connection from the DB2 client and Tivoli Storage Manager Server succeeded through the Tivoli Storage Manager console (run the **query session** command). The result is shown in Example 9-38.

### *Example 9-38 Session list*

---

```
sm: TSM>q ses
```

Sess Number	Comm. Method	Sess State	Wait Time	Bytes Sent	Bytes Recvd	Sess Type	Platform	Client Name
-----	-----	-----	-----	-----	-----	-----	-----	-----
1,314	Tcp/Ip	Run	0 S	79.7 K	1.5 K	Admin	AIX	ADMIN

## 9.8.5 Getting reports from backup

This section describes how to get information after the backup execution completes. This is required in order to check the backup return code, backup log files, and to create backup reports.

### Listing backup Information using `backom`

Using `backom` commands, you can extract history from all backups taken from Data Protection for SAP for DB2. The complete `backom` command reference can be found at the following address:

<http://publib.boulder.ibm.com/infocenter/tivihelp/v1r1/index.jsp?topic=/com.ibm.itserp.doc/fbrd000050.htm>

You can perform the following functions:

- ▶ List all backup objects related to DB2. This command lists all database or tablespace backups and DB2 log file backups:
 

```
backom -c q_all [-i <instance>] [-a <database alias>] [-n <node number>] [-t <timestamp | time range>] [-l <log number | log number range>] [-e <execution profile>] [-m <output mode>] [-v]
```
- ▶ List database backups. This command lists all backups from a specific database:
 

```
backom -c q_db [-i <instance>] [-a <database alias>] [-n <node number>] [-t <timestamp | time range>] [-e <execution profile>] [-m <output mode>] [-v]
```
- ▶ List tablespace backups. This command lists all backups from a specific tablespace:
 

```
backom -c q_ts [-i <instance>] [-a <database alias>] [-n <node number>] [-t <timestamp | time range>] [-e <execution profile>] [-m <output mode>] [-v]
```
- ▶ List tablespace definition information images. This command lists tablespace definition information (TDI) images related to a full DB2 database backup:
 

```
backom -c q_tdi -a <database alias> -t <timestamp> [-i <instance>] [-n <node number>] [-e <execution profile>] [-m <output mode>] [-v]
```
- ▶ List DB2 log file backups. This command lists all DB2 log backup:
 

```
backom -c q_log [-a <database alias>] [-n <node number>] [-t <timestamp | time range>] [-l <log number | log number range>] [-e <execution profile>] [-m <output mode>] [-v]
```

- List backup objects available on Tivoli Storage Manager. This command lists backup objects available on Tivoli Storage Manager (database or tablespace backups, DB2 log file backups, and file backups):

```
backom -c q_raw [-f <file name>] [-e <execution profile>] [-m
<output mode>] [-v]
```

## Listing backup information from the DB2 Command Line Processor

From the DB2 Command Line Processor (CLP), you can list all backup history from the specific database. To list all backup history for a database called QAS, use **db2 list history backup all for db QAS**. The result is shown in Example 9-39.

*Example 9-39 Partial list of db2 list history backup for database QAS*

```
desmoines01:db2qas 20> db2 LIST HISTORY BACKUP ALL FOR DB QAS
```

List History File for QAS

Number of matching file entries = 73

Op	Obj	Timestamp+Sequence	Type	Dev	Earliest Log	Current Log	Backup ID
B	D	20080808185040001	F	D	S0000000.LOG	S0000000.LOG	

Contains 34 tablespace(s):

```
00001 SYSCATSPACE
00002 SYSTOOLSPACE
00003 QAS#DBD
00004 QAS#DBI
00005 QAS#FACTD
00006 QAS#FACTI
00007 QAS#EL700D
00008 QAS#EL700I
00009 QAS#CLUD
00010 QAS#CLUI
00011 QAS#LOADD
00012 QAS#LOADI
00013 QAS#SOURCED
00014 QAS#SOURCEI
00015 QAS#USER1D
00016 QAS#USER1I
00017 QAS#ES700D
```



```
00018 QAS#ES700I
00019 QAS#PROTD
00020 QAS#PROTI
00021 QAS#ODSD
00022 QAS#ODSI
00023 QAS#DOCUD
00024 QAS#DOCUI
00025 QAS#STABD
00026 QAS#STABI
00027 QAS#BTABD
00028 QAS#BTABI
00029 QAS#POOLD
00030 QAS#POOLI
00031 QAS#DIMD
00032 QAS#DIMI
00033 QAS#DDICD
00034 QAS#DDICI
```

---

To get the complete list of the database archivelog backups, you can use the **db2 list history archivelog all** command. The complete format of the command **db2 list history** can be found at the following address:

<http://publib.boulder.ibm.com/infocenter/db2luw/v9/index.jsp?topic=/com.ibm.db2.udb.admin.doc/doc/r0001991.htm>

### Listing backup information from DB2 tables

You can get the same information listed by the **db2 list history** command from the DB2 table `sysibmadm.db_history` (available for DB2 Version 9 and above). However, we strongly suggest that you use the **backom** command instead. This method is mostly used when you are required to process the information (using your own tools) or create an customized report.

Example 9-40 shows the SQL command to list all backups from a DB2 instance.

*Example 9-40 Getting backup information from DB2 table*

---

```
db2 => select start_time, end_time , substr(comment,1,30) FROM
SYSIBMADM.DB_HISTORY WHERE OPERATION = 'B' AND OPERATIONTYPE = 'F'
```

```
START_TIME      END_TIME      3
-----
20080808185040 20080808190533 DB2 BACKUP QAS OFFLINE
20080903155506 20080903160133 DB2 BACKUP QAS OFFLINE
20080916170618 20080916171958 DB2 BACKUP QAS OFFLINE
20080917101256 20080917101327 DB2 BACKUP QAS OFFLINE
```

```
20080917132110 20080917132111 DB2 BACKUP QAS OFFLINE
20080917143131 20080917143132 DB2 BACKUP QAS OFFLINE
20080917143647 20080917143648 DB2 BACKUP QAS OFFLINE
20080919103555 20080919103557 DB2 BACKUP QAS OFFLINE
20080919112156 20080919113723 DB2 BACKUP QAS OFFLINE
20080925163934 20080925163935 DB2 BACKUP QAS OFFLINE
```

10 record(s) selected.

---

A complete description of the sysibmadm.db\_history table can be found at the following address:

<http://publib.boulder.ibm.com/infocenter/db2luw/v9/index.jsp?topic=/com.ibm.db2.udb.admin.doc/doc/r0022351.htm>

## 9.8.6 Releasing tapes and backup expiration

For Tivoli Storage Manager for ERP using the **backom** interface, there are the following options to release tapes used by DB2 backups:

- ▶ Releasing DB2 online backups: You can use the following command to release database backups taken by Data Protection:

```
backom -c d_db -a <database alias> -t <timestamp | time range> [-i
<instance>] [-n <node number>] [-e <execution profile>] [-x] [-v]
```

- ▶ Releasing DB2 log backups: You can use the following command to release log backups taken by Data Protection:

```
backom -c d_log -a <database alias> -l <log number|log number range>
[-n <node number>] [-t <timestamp|time range>] [-e <execution
profile>] [-x] [-v]
```

## 9.9 Troubleshooting

This section shows some troubleshooting procedures to fix configuration and backup and restore problems.

This section helps you with setup problems and defects. If you encounter a performance problem, refer to *Planning Data Protection for SAP Installation and User's Guide for DB2*, SC33-6341.

If an error occurs, check the description of the error message. Besides being displayed on the screen, the error messages also can be found in log files. Resolve the problem indicated in the error message and retry the action.

## 9.9.1 Log files

The following is a list of error log files that can give you valuable information to use in problem determination. They are relevant for backing up DB2 using Tivoli Storage Manager.

- ▶ DSIERROR.LOG

The file resides in the directory specified by the DSMI\_LOG environment variable. It contains the most valuable information for problem determination for our purposes. Each entry may refer to a Tivoli Storage Manager API error number. A description of those errors can be found in Appendix D, “API Return Codes”, in *Tivoli Storage Manager Using the Application Program Interface V4R1*, SH26-4123.

- ▶ <db2home>/sql11ib/db2dump/db2diag.log

This is the DB2 error log. All database incidents and events are sent to this log.

Everything you see on the screen during operation of DB2 backup, DB2 restore, or BackOM in general will also be written to the log files. Data Protection for SAP process results are logged in files. These files are located in the path indicated by the environment variable TDP\_DIR. After the installation, TDP\_DIR points to the subdirectory tdplog of the path for the Tivoli Data Protection for SAP configuration files. If TDP\_DIR is not set or if a log file cannot be created in the path pointed to by TDP\_DIR, the log files are created in the path /tmp UNIX.

The following log files are written:

- ▶ Data Protection for SAP shared library: tdpdb2.<SID>.<node name>.log
- ▶ Backup Object Manager: backom.log

## 9.9.2 Configuration files

The most common problems are related to the configuration file location. If you have a problem with this item, here are some checks that you can perform:

- ▶ Check the Tivoli Storage Manager client environment variables setting. In an AIX environment, you can execute the command **env | grep DSMI**. The result is shown in Example 9-41.

*Example 9-41 env|grep DSMI command*

---

```
# env | grep DSMI
DSMI_DIR=/usr/tivoli/tsm/client/api/bin64
DSMI_CONFIG=/usr/tivoli/tsm/client/api/bin64/dsm.opt
DSMI_LOG=/var/log/tsm
```

---

- ▶ Usually, all Tivoli Storage Manager environment variables are assigned during the DB2 owner account login. To find the correct login script, do the following steps:
  - a. Get information about the default shell using the command `echo $SHELL`.
  - b. List the home directory to get the login script. It is `.cshrc` for a C shell or `.profile` for a Korn shell or Bourne shell.
  - c. Look at the script `.tsmenv.csh`, `.tsmenv.sh`, or `.tsmenv.ksh`, according to the default shell used. This script defines and assigns a value to all Tivoli Storage Manager environment variables, as shown in Example 9-42.

*Example 9-42 Listing of environment*

---

```

desmoines01:db2qas 6> echo $SHELL
/bin/csh
desmoines01:db2qas 7> ls -a .*
.                .dbsrc.sh
.sapenv_desmoines01.csh
..               .login
.sapenv_desmoines01.sh
.cshrc           .login.1        .sapenv_thick01.csh
.cshrc.1        .login.2        .sapenv_thick01.sh
.dbenv.csh      .mh_profile     .sapenv_thick02.sh
.dbenv.sh       .profile        .sapsrc.csh
.dbenv_desmoines01.csh .profile.1     .sapsrc.sh
.dbenv_desmoines01.sh .rhosts        .sh_history
.dbenv_thick01.csh .rhosts.1      .tsmenv.csh
.dbenv_thick01.sh .sapenv.csh    .vi_history
.dbsrc.csh      .sapenv.sh

```

---

### 9.9.3 Common error messages

The `DSMI_LOG` environment variable or the `dsm.sys` file `ERRORLOGNAME` option must be set to a path that the user of the application can write to. If the user performing the backup and restore does not have write permissions to the log file, the process will fail. The Tivoli Storage Manager API return code for this situation is 106, access to the specified file or directory is denied.

The possible messages are:

SQL2062N An error occurred while accessing media  
"/.../sql1lib/adsm/libtsm.a". Reason code: "106".

or

ANS 1003E Backup failed to start for node XXX, file system XXXX, errno  
= 106

Ensure that the DB2 instance owner running the backup operation has full write  
authority to this error log.

### 9.9.4 Other problems

Other problem determination and troubleshooting procedures can be found at the  
following address:

[http://publib.boulder.ibm.com/infocenter/tivihelp/v1r1/topic/com.ibm.it  
smerp.doc/fbrd000078.htm](http://publib.boulder.ibm.com/infocenter/tivihelp/v1r1/topic/com.ibm.it<br/>smerp.doc/fbrd000078.htm)

## 9.10 References

- ▶ Considerations for using Tivoli Storage Manager:  
[http://publib.boulder.ibm.com/infocenter/db2luw/v9/index.jsp?topic=/  
com.ibm.db2.udb.admin.doc/doc/c0024708.htm](http://publib.boulder.ibm.com/infocenter/db2luw/v9/index.jsp?topic=/<br/>com.ibm.db2.udb.admin.doc/doc/c0024708.htm)
- ▶ Configuring a Tivoli Storage Manager client:  
[http://publib.boulder.ibm.com/infocenter/db2luw/v9/index.jsp?topic=/  
com.ibm.db2.udb.admin.doc/doc/t0024706.htm](http://publib.boulder.ibm.com/infocenter/db2luw/v9/index.jsp?topic=/<br/>com.ibm.db2.udb.admin.doc/doc/t0024706.htm)
- ▶ db2adutl - Managing DB2 objects within TSMcommand:  
[http://publib.boulder.ibm.com/infocenter/db2luw/v9/index.jsp?topic=/  
com.ibm.db2.udb.admin.doc/doc/r0002077.htm](http://publib.boulder.ibm.com/infocenter/db2luw/v9/index.jsp?topic=/<br/>com.ibm.db2.udb.admin.doc/doc/r0002077.htm)
- ▶ *IBM Tivoli Storage Manager for Enterprise Resource Planning - Data  
Protection for SAP - Installation and User's Guide for DB2*, found at:  
[http://publib.boulder.ibm.com/infocenter/tivihelp/v1r1/index.jsp?top  
ic=/com.ibm.itsmerp.doc/fbrd0000.htm](http://publib.boulder.ibm.com/infocenter/tivihelp/v1r1/index.jsp?top<br/>ic=/com.ibm.itsmerp.doc/fbrd0000.htm)
- ▶ IBM DB2 Database for Linux, UNIX, and Windows Information Center:  
[http://publib.boulder.ibm.com/infocenter/db2luw/v9/index.jsp?topic=/  
com.ibm.db2.udb.doc/welcome.htm](http://publib.boulder.ibm.com/infocenter/db2luw/v9/index.jsp?topic=/<br/>com.ibm.db2.udb.doc/welcome.htm)

- ▶ Developing a backup and recovery strategy:  
<http://publib.boulder.ibm.com/infocenter/db2luw/v9/index.jsp?topic=/com.ibm.db2.udb.admin.doc/doc/c0005945.htm>
- ▶ *Data Protection for SAP - Installation and User's Guide for DB2, SC33-6341*
- ▶ *IBM Tivoli Storage Management Concepts, SG24-4877*

# Oracle backup using Tivoli Storage Manager for ERP

This chapter discusses implementing Data Protection for SAP using Tivoli Storage Manager for ERP - Oracle. The chapter is based on our case study that was tested in our lab environment. The objective of the case study was to implement a Tivoli Storage Manager solution for an SAP system based on Oracle database. This chapter consists of the following sections:

- ▶ 10.1, "Introduction" on page 268
- ▶ 10.2, "Data protection planning for SAP with Oracle" on page 270
- ▶ 10.3, "Tivoli Storage Manager for ERP - Oracle installation" on page 275
- ▶ 10.4, "BR\*Tools with Oracle RMAN configuration" on page 278
- ▶ 10.5, "Configuration of BR\*Tools with the BACKINT interface" on page 288
- ▶ 10.6, "References" on page 290

## 10.1 Introduction

This section introduces the concepts of Data Protection for SAP. There are two interfaces you can use: BACKINT or Oracle Recovery Manager. We discuss both interfaces in these sections:

- ▶ 10.1.1, “Data Protection for SAP and BACKINT” on page 268
- ▶ 10.1.2, “Data Protection for SAP and RMAN” on page 269

### 10.1.1 Data Protection for SAP and BACKINT

BR\*Tools uses tables in the Oracle database and system data in order to record the status of the data file backups and log file backups. This information allows SAP to automatically restore the correct data files and their specific database transaction log files (redo log files), if necessary. The data files reside in the Oracle database. Data Protection for SAP runs as a separate process, independently from the database. It receives the data through the BACKINT interface and saves the data to the Tivoli Storage Manager.

Figure 10-1 shows the interaction between BR\*Tools, Data Protection for SAP, and the BACKINT interface in order to perform backups and restores.

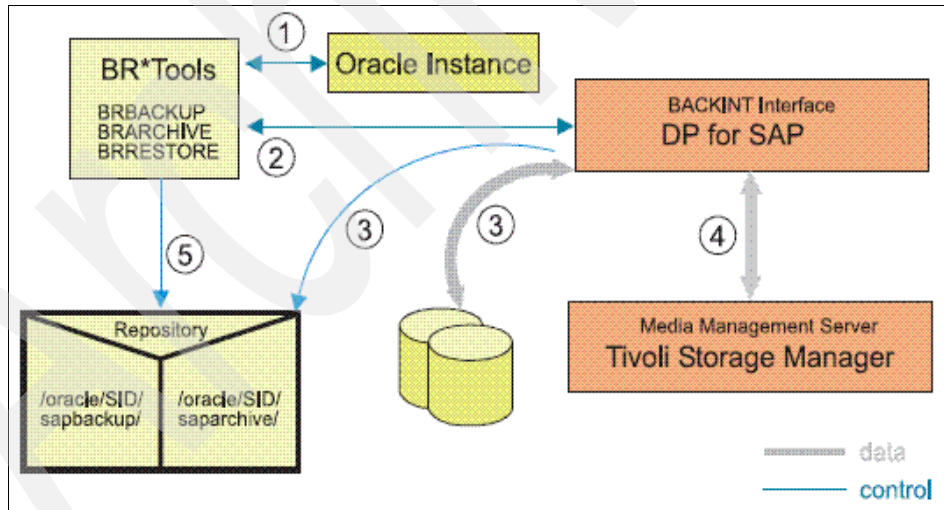

Figure 10-1 Data Protection for SAP with BR\*Tools using the BACKINT Interface

Based on the interaction shown in Figure 10-1, a backup proceeds as follows:

1. BR\*Tools utility BRBACKUP informs Oracle what data has to be backed up and puts the database into the proper backup state, online or offline.



2. BRBACKUP calls Data Protection for SAP using the BACKINT interface with a list of all files to be backed up.
3. Data Protection for SAP reads all the requested files from the database and reports back to BRBACKUP. BRBACKUP adds these files to the repository containing all processed backups.
4. BACKINT saves the data to Tivoli Storage Manager.
5. BR\*Tools updates the file repository containing information about the status of the files.

## 10.1.2 Data Protection for SAP and RMAN

BR\*Tools uses tables in the Oracle database and system data in order to record the status of the database and redo log backups. This information allows SAP to automatically restore the correct data and its corresponding redo logs. The data files reside in the Oracle database (Oracle instance). Data Protection for SAP runs as a linked library controlled by the Oracle server process.

Figure 10-2 shows the interaction between BR\*Tools, Data Protection for SAP, and the RMAN interface in order to do backups and restores.

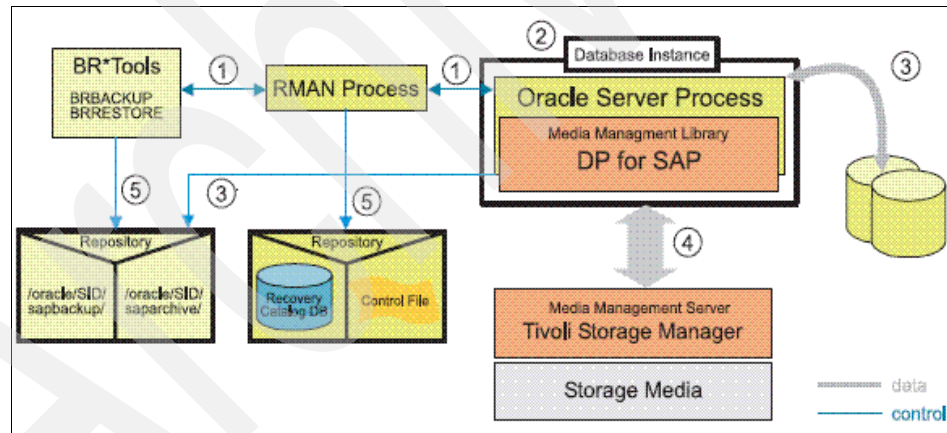

Figure 10-2 Data Protection for SAP with BR\*Tools using the RMAN Interface

Based on the interaction shown in Figure 10-2, a backup proceeds as follows:

1. BR\*Tools utility BRBACKUP informs Oracle RMAN what data has to be backed up. The RMAN process puts the database into the proper backup state, online or offline.
2. The Oracle server process loads Data Protection for SAP and interacts with it through the Media Management API.

3. Data Protection for SAP reads the requested data from the database and reports back to BRBACKUP. BRBACKUP adds this data to the repository containing all processed backups.
4. Data Protection for SAP saves the data to a Tivoli Storage Manager server.
5. BR\*Tools updates the repository containing information about the status of the data. RMAN has its own repository, with a control file for a separate recovery catalog database.

## 10.2 Data protection planning for SAP with Oracle

In this section, we describe planning and preparation for the implementation of Data Protection for SAP. The topics include:

- ▶ 10.2.1, “Lab environment overview and backup considerations” on page 270
- ▶ 10.2.2, “Backup methods to be used” on page 272
- ▶ 10.2.3, “Installation prerequisites for Data Protection for SAP - Oracle” on page 272
- ▶ 10.2.4, “Tivoli Storage Manager software packages to be used” on page 273
- ▶ 10.2.5, “Defining backup policies” on page 273

### 10.2.1 Lab environment overview and backup considerations

Our lab environment is shown in Figure 10-3.

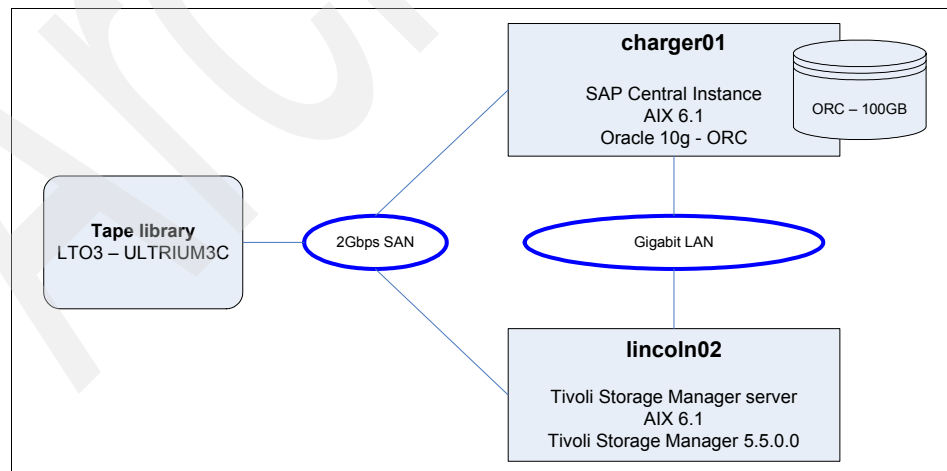

Figure 10-3 Environment configuration

In our lab environment, the SAP central instance and database are located on a partition called charger01 running AIX Version 6.1. Tivoli Storage Manager server runs on another AIX V6.1 machine called lincoln02.

SAP system data is stored in an Oracle database (Version 10g). The System ID of our database is ORC. The size of database ORC is around 100 GB. The service level requirements of the backup solution are listed in Table 10-1.

*Table 10-1 Parameters required for Oracle backup and restore*

Parameter	Required value
Application	SAP
Recovery Time Objective (RTO)	3 hours
Recovery Point Objective (RPO)	2 hours
Data size	100 GB
Backup retention	30 days
Data type	Oracle database
Database in archive mode	Yes
Recovery Time Granularity (RTG)	any point in time

A tape library with three LTO3 drives is attached to the Tivoli Storage Manager server through a 2 Gbps SAN network. Table 10-2 lists the performance characteristics of Linear Tape Open (LTO) drives.

*Table 10-2 LTO drive characteristics*

Drive type	Cartridge capacity native/compressed (GB)	Drive throughput native /compressed (MBps)	File access time (seconds)
LTO4	800/1600	120/240	100
LTO3	400/800	80/160	68
LTO2	200/400	35/70	49
LTO1	100/200	15/30	54

Based on Table 10-2, the performance parameters of an LTO3 drive are as follows:

- ▶ Transfer rate of 80 MBps (native) / 160 MBps (with data compression)
- ▶ Cartridge capacity of 400 GB (native) / 800 GB (with data compression)

The device class TAPE defined on the Tivoli Storage Manager server for the library is of type ULTRIUM3C. The suffix C in ULTRIUM3C indicates that hardware compression is enabled on the LTO3 drives.

The Tivoli Storage Manager server is connected with the SAP server through a 1 Gbps LAN. According to Table 10-3, we can expect a real transfer speed of 180 GB/hr.

Table 10-3 Common LAN throughputs

Technology	MBps	Assumed speed
Fast Ethernet	100 MBps	18 GB/hr at 40% efficiency
Gigabit Ethernet	1000 MBps	180 GB/hr at 40% efficiency
T1	1.54 MBps	0.5 GB/hr at 80% efficiency
T3	45 MBps	16 GB/hr at 80% efficiency

For the requirements in Table 10-1 on page 271, let us calculate the throughput:

- ▶ For RTO, we need a restore speed of at least 100 GB / 2 hours or 50 GB/hr. This can be satisfied by both the LTO3 drive transfer speed and Gigabit Ethernet assumed speed.
- ▶ The backup rate for 100 GB data can be transferred to the tape library in less than 35 minutes. We do not have to consider any other enhancements, such as LAN-free backup, parallelism, or multiplexing.

## 10.2.2 Backup methods to be used

We use BR\*Tools as a database backup tool. In the first step, we set up BR\*Tools to transfer data using an RMAN channel defined with an SBT API adapter. The adapter is provided by Tivoli Storage Manager for ERP. In the second test, we reconfigure BR\*Tools to use the Tivoli Storage Manager BACKINT interface.

## 10.2.3 Installation prerequisites for Data Protection for SAP - Oracle

The following products must be installed before you can start setting up Tivoli Storage Manager for ERP - Oracle:

- ▶ Oracle Database
- ▶ SAP or SAP e-business Solution, based on Oracle
- ▶ Tivoli Storage Manager client
- ▶ Supported operating system for SAP and Tivoli Storage Manager client

For hardware and software prerequisites, as well as product versions supported and maintenance levels required by the current version of Data Protection for SAP and the Administration Assistant, refer to the Release Notes in the Tivoli Information Center found at the following address:

[http://publib.boulder.ibm.com/infocenter/tivihelp/v1r1/topic/com.ibm.it-smreadme.doc\\_5.5/relnotes.html](http://publib.boulder.ibm.com/infocenter/tivihelp/v1r1/topic/com.ibm.it-smreadme.doc_5.5/relnotes.html)

## 10.2.4 Tivoli Storage Manager software packages to be used

We use the following software components:

- ▶ Tivoli Storage Manager client API 64-bit Version 5.5.0.0
- ▶ Tivoli Storage Manager Backup Archive client Version 5.5.0.0
- ▶ Tivoli Storage Manager for Enterprise Resource Planning (Oracle) Version 5.5.0.0

## 10.2.5 Defining backup policies

According to the calculations found in 10.2.1, “Lab environment overview and backup considerations” on page 270, we assume that a restore of a 100 GB database can be accomplished in less than 35 minutes.

The database operates in archive mode and the point in time restore option is required. Therefore, in addition to backing up data files, we also back up offline redo logs generated by Oracle. Because the Recovery Point Objective (RPO) is 2 hours, offline redo log files have to be backed up every 2 hours by the **brarchive** command called automatically from the Tivoli Storage Manager scheduler. The offline redo log files that have been backed up to Tivoli Storage Manager are removed from the local archivelog directory by the **brarchive** tool.

To minimize the number of log files needed for a point in time recovery, we schedule a full online backup of the database every 24 hours. The backup retention required for this solution is 30 days. Therefore, we can assume that the total size of all backup images will be  $30 \times 100 \text{ GB} = 3 \text{ TB}$ .

Also we have to consider the space on backup storage required for offline redo log files. For our database, we suppose it can be 500 to 1000 GB for 30 days. In general, the space required for backups of redo logs depends on the volume of transactions on database.

Thus, we estimate that for this solution the total storage requirements on the backup media will be 4 TB, so we will need five LTO3 cartridges.

## General considerations

Tivoli Storage Manager provides several options to enhance backup and restore performance.

- ▶ You can set up Tivoli Storage Manager for ERP to back up and restore data to multiple drives in parallel.
- ▶ You can enable multiplexing, which allows you to simultaneously transfer data from different data files through one session to exploit the throughput provided by a tape drive.
- ▶ Disk sorting is an enhancement used by Tivoli Storage Manager for ERP to minimize the backup protection window. It sorts database files in order to avoid simultaneous reading of the files residing on the same disk.
- ▶ Another option to enhance backup and restore is to use multiple network paths to balance network traffic across all available network connections to the Tivoli Storage Manager server.

On a Tivoli Storage Manager server, you can also enable collocation to keep data of one node (or a group of nodes) together on one tape (or on the same group of tapes). We recommend deactivating collocation for backups with Tivoli Storage Manager for ERP in order to enable parallel sessions to use multiple tape drives in parallel. Collocation must also be deactivated in order to use the multiple log copy function.

In our lab environment, we set up tape storage pool as a destination for Oracle data files backup, as the transfers of large files can easily exploit the backup throughput of a sequential medium.

In this solution, a client scheduler triggers a backup of offline redo log files every 2 hours. To avoid a tape mount every time the log backup is performed, we use a disk-tape storage pool hierarchy for the backup of log files.

## Backup retention

The retention period required for backup for this solution is 30 days. There are two possible ways to control the data retention if using Tivoli Storage Manager for ERP: Either Tivoli Storage Manager for ERP backup version control can be used, or you can use the Tivoli Storage Manager server expiration function.

We set the deletion of obsolete backup versions to be driven by Tivoli Storage Manager for ERP. Therefore, both archive copy groups for data files backup and log files backup are configured with parameter `RETVER=NOLIMIT`, so that the files are not considered expired and deleted by the Tivoli Storage Manager server.

You can enable versioning by using the parameter `MAX_VERSIONS` in the Tivoli Storage Manager for ERP configuration file (`init<SID>.utl`). The required backup retention period is 30 days, and we plan to trigger a full backup daily. Therefore, we set `MAX_VERSIONS=30`.

## 10.3 Tivoli Storage Manager for ERP - Oracle installation

The installation packages are located on the Data Protection for SAP CD-ROMs. The CD-ROMs images can be downloaded using Passport Advantage.

Initial installations must always be done from the CD-ROM or its image, as it contains the license file. Refer to the file `README.1ST` in the root path for information about where to find documents on the CD or image, and follow the appropriate installation description.

If you are going to upgrade from an earlier version of Tivoli Storage Manager for ERP in your environment, you have the option to either upgrade from the product CD-ROM or image, or to download the latest version from the IBM public FTP server. You can get more information about this task at the following address:

<http://www.ibm.com/software/sysmgmt/products/support/IBMTivoliStorageManagerforEnterpriseResourcePlanning.html>

Tivoli Storage Manager for ERP is delivered as a single executable file for all supported platforms. The packages are named as follows:

- ▶ For a CD or CD image, the name has the format `<version>-TIV-TSMERPORA-<platform>`. See the `README.1ST` file in the root directory of the CD or CD image for a list of its contents.
- ▶ Packages on the FTP server contain `FTP` as a prefix to the platform designation.

The package files have an extension appropriate to the platform and are executable.

When you invoke the file, you will be guided through the Tivoli Storage Manager for ERP setup procedure. To ensure that the setup procedure is carried out properly, read the description carefully and follow the guidelines in the windows that are displayed during setup.

**Note:** The default path for the Tivoli Storage Manager for ERP installation on AIX operating system is `/usr/tivoli/tsm/tdp_r3`.

We perform the following steps to install Tivoli Storage Manager for ERP - Oracle:

1. Log in as root user to server charger01.
2. Install the Tivoli Storage Manager API client on charger01.
3. Invoke the installation file for Tivoli Storage Manager for ERP - Oracle for the AIX operating system. For this installation, we specified the parameter `-console` so we can run the installation from a telnet client. In case you run the installation from an X Window System terminal, you can execute the installation binary file with no parameters, which invokes a Java-based installation GUI.

*Example 10-1 Installation of Tivoli Storage Manager for ERP*

---

```
/tmp/backup/5.5.0.0-TIV-TSMERPORA-AIX.bin -console
```

---

4. We used the following installation parameters:

<b>Oracle SID</b>	ORC
<b>SAP configuration file</b>	/oracle/ORC/102_64/dbs
<b>dsm.sys stanza</b>	TSM1_TDP_ORACLE
<b>Tivoli Storage Manager node name</b>	CHARGER01_TDP
<b>Backup management class</b>	DBBACKUPS
<b>Archive management class</b>	LOGS
<b>Install Oracle RMAN support</b>	Yes

The installation process is shown in Example 10-2.

*Example 10-2 Example of Tivoli Storage Manager for ERP - Oracle installation process*

---

```
Please enter the required information
```

```
Enter Oracle SID [SID] ORC
```

```
Press 1 for Next, 2 for Previous, 3 to Cancel or 5 to Redisplay [1]
```

```
-----  
Please enter the required information
```

```
Enter directory where the SAP BR-Tools are located.  
[/usr/sap/ORC/SYS/exe/run] /usr/sap/ORC/SYS/exe/run
```



Enter directory where the SAP configuration file (initSID.sap) is located. [/oracle/ORC/dbs] **/oracle/ORC/102\_64/dbs**

Press 1 for Next, 2 for Previous, 3 to Cancel or 5 to Redisplay [1]

-----  
To connect to the Administration Assistant Server the following information is needed. If you do not specify a server, the connection will be disabled.

Enter network address of Administration Assistant Server [**charger01**]  
Enter port for Administration Assistant Server [**5126**]

Press 1 for Next, 2 for Previous, 3 to Cancel or 5 to Redisplay [1]

-----  
To connect to the Tivoli Storage Manager server with basic settings the installer updates the configuration files with the provided parameters. If you do not want the parameters updated answer the next question with NO.

Should the installer update these settings?

- 1 - Yes (recommended for first time installation)
- 2 - No (recommended for update installation)

To select an item enter its number, or 0 when you are finished [0]:

enter Tivoli Storage Manager server. The name must already exist in dsm.sys. [TSMSESV] **TSM1\_TDP\_ORACLE**  
enter TSM node name [R3NODE] **charger01\_tdp**  
enter backup management classes [MDB] **dbbackups**  
enter archive management classes [MLOG1 MLOG2] **logs**

Press 1 for Next, 2 for Previous, 3 to Cancel or 5 to Redisplay [1]

-----  
To support Oracle RMAN with Data Protection for SAP a shared library must be installed. In addition some action must be done to link the oracle executable against this library. For more information read the installation manual.

Do you want to install Oracle RMAN support?

- 1 - Yes

[ ] 2 - No

To select an item enter its number, or 0 when you are finished [0]:

Press 1 for Next, 2 for Previous, 3 to Cancel or 5 to Redisplay [1]

-----  
Data Protection for SAP will be installed in the following location:  
/usr/tivoli/tsm/tdp\_r3/ora64  
-----

## 10.4 BR\*Tools with Oracle RMAN configuration

The integration of BR\*Tools with Oracle RMAN instructs BR\*Tools to allocate a dynamic RMAN channel, which is used to transfer backup data to and from a Tivoli Storage Manager server.

### 10.4.1 Tivoli Storage Manager server configuration

We perform the following on the Tivoli Storage Manager server called lincoln02 for Data Protection for SAP - Oracle:

1. We define the policy domain DATABASE\_TDP with two management classes for backup of data files (DBBACKUPS) and for backup of redo log files (LOGS).
2. We define an archive copy group within each of the management classes. The backup retention control is performed by Tivoli Storage Manager for ERP. Therefore, we define archive copy groups for each management class with parameter RETVER=nolimit, which means that Tivoli Storage Manager server will not make backup versions expire.
  - For the archive copy group in the DBBACKUPS management class, the destination storage pool BACKUPTAPE is of device type TAPE.
  - For the archive copy group in the LOGS management class, the destination storage pool BACKUPDISK is of device type DISK.
3. Storage pool BACKUPTAPE is the next storage pool for storage pool BACKUPDISK in the storage hierarchy. Therefore, data from BACKUPDISK will automatically migrate to BACKUPTAPE.
4. We register the Tivoli Storage Manager node with the DATABASE\_TDP policy domain and set the parameters for a Tivoli Storage Manager node, as shown in Example 10-3 on page 279.

---

```
TSM1>reg node charger01_tdp passw0rd doma=DATABASE_TDP maxnummp=2
```

---

## 10.4.2 SAP database server configuration

This section explains the configuration for Data Protection for SAP on the SAP database server machine (charger01):

1. Add a server stanza in `dsm.sys` as the configuration profile of Tivoli Storage Manager API client:
  - We define a server called `TSM1_TDP_ORACLE` in a server stanza.
  - The parameter `PASSWORDACCESS` had been set to `PROMPT`.
  - The host name of the Tivoli Storage Manager server (`lincoln02`) is added to the server stanza.

We do not include the Tivoli Storage Manager node name within this server stanza. The Tivoli Storage Manager node is specified in the configuration profile of Tivoli Storage Manager for ERP (`init0RC.ut1`) that will refer to this server stanza, as shown in Example 10-4.

*Example 10-4 TSM1\_TDP\_ORACLE server stanza*

---

```
SErvername TSM1_TDP_ORACLE  
COMMMethod TCPip  
TCPPort 1500  
TCPSeveraddress lincoln02  
passwordaccess prompt
```

---

2. Define a second stanza in `dsm.sys` for Tivoli Storage Manager Backup Archive Client for backup of file systems. Example 10-5 shows this `TSM1_FS` stanza.
  - This stanza is also used by the Tivoli Storage Manager client scheduler to authenticate with the Tivoli Storage Manager server as node `charger01_fs`.
  - The value of parameter `PASSWORDACCESS` in `TSM1_FS` stanza is `generate`, so the Backup Archive Client and client scheduler store the password locally after the initial invocation. The client scheduler can then be started automatically from `/etc/inittab`.
  - Tivoli Storage Manager node `charger01_fs` is a member of policy domain `FSBACKUPS`, so all the schedules associated with `charger01_fs` have to be defined in the same policy domain.

*Example 10-5 /usr/tivoli/tsm/client/api/bin64/dsm.sys*

---

```
SErvername TSM1_FS
COMMMethod TCPip
TCPPort 1500
TCPServeraddress lincoln02
passwordaccess generate
nodename charger01_fs
```

---

3. We decide to use the same `dsm.sys` profile file for Tivoli Storage Manager Backup Archive Client and for Tivoli Storage Manager API client. We create a symbolic link for `dsm.sys` in the Tivoli Storage Manager Backup Archive Client installation directory pointing to `dsm.sys` in the Tivoli Storage Manager API directory, as shown in Example 10-6.

*Example 10-6 Create link to dsm.sys file*

---

```
ln -s /usr/tivoli/tsm/client/api/bin64/dsm.sys
/usr/tivoli/tsm/client/ba/bin/dsm.sys
```

---

4. Preparation for the `oraorc` user:
  - Adding Tivoli Storage Manager API variables: Add `DSMI_DIR` and `DSMI_LOG` to the `oraorc` user profile. Example 10-7 on page 281 shows the additional lines.
  - Creating error log directory `/var/log/tsm`: Adjust the access rights to enable the `oraorc` user to perform read and write operations to the log directory (`chmod ugo+rw /var/log/tsm`).

*Example 10-7 Lines added to .cshrc profile of the oraorc user*

---

```
setenv DSMI_DIR /usr/tivoli/tsm/client/api/bin64
setenv DSMI_LOG /var/log/tsm
```

---

5. The Tivoli Storage Manager for ERP installation creates a profile shown in Example 10-8. It contains the parameters specified during the installation and some additional settings.

In the installation shown in Example 10-2 on page 276, we specify:

- Tivoli Storage Manager node name: charger01\_tdp
- Tivoli Storage Manager management classes that will be used for data (DBBACKUPS) and redo logs backup (LOGS)
- The server stanza in the `dsm.sys` called `TSM1_TDP_ORACLE` to be used for the `SERVER` parameter in this configuration

*Example 10-8 /oracle/ORC/102\_64/dbs/initORC.utl*

---

```
BACKUPIDPREFIX      ORC___
MAX_SESSIONS        2
MAX_BACK_SESSIONS   2
MAX_ARCH_SESSIONS   2
REDOLOG_COPIES      2
RL_COMPRESSION      YES
MULTIPLEXING        2
BUFFSIZE            131072
MAX_VERSIONS      30
BATCH               YES
EXITONERROR         yes
REPORT              2
TRACEMAX            10000
CONFIG_FILE         /oracle/ORC/102_64/dbs/initORC.bki
SERVER TSM1_TDP_ORACLE
SESSIONS            2
PASSWORDREQUIRED    YES
ADSMNODE          charger01_tdp
BRBACKUPMGTCCLASS dbbackups
BRARCHIVEMGTCCLASS logs
USE_AT              0 1 2 3 4 5 6
END
```

---

6. On the Tivoli Storage Manager server, the archive copy groups for SAP data and logs are set with `RETVER=NOLIMIT`. We have to instruct Tivoli Storage Manager for ERP to perform the expiration of the obsolete backup versions. This is set by updating the `MAX_VERSIONS` parameter in `initORC.utl`. In

Example 10-8 on page 281, we set Tivoli Storage Manager for ERP to retain 30 backup versions.

7. We switched the user from root to oraorc and updated the locally stored password for Tivoli Storage Manager node charger01\_tdp, as shown in Example 10-9.

*Example 10-9 Update the Tivoli Storage Manager node password*

---

```
# su - oraorc
oraorc 1> backint -p /oracle/ORC/102_64/dbs/initORC.utl -f password
                        Data Protection for SAP(R)

Interface between BR*Tools and Tivoli Storage Manager
- Version 5, Release 5, Modification 0.0 for AIX LF 64-bit -
  Build: 316B compiled on Oct 23 2007
(c) Copyright IBM Corporation, 1996, 2007, All Rights Reserved.

BKI2027I: Using TSM-API version 5.5.0.0 (compiled with 5.3.0.0).
BKI2000I: Successfully connected to ProLE on port tdpr3ora64.
BKI0005I: Start of program at: Mon Sep 29 13:44:38 CDT 2008 .
BKI0049I: Please enter password for node CHARGER01_TDP on server
TSM1_TDP_ORACLE:
BKI0051I: Password successfully verified for node CHARGER01_TDP on
server TSM1_TDP_ORACLE.
BKI0020I: End of program at: Mon Sep 29 13:44:45 CDT 2008 .
BKI0021I: Elapsed time: 07 sec .
BKI0024I: Return code is: 0.
```

---

8. We have to make sure RMAN can access the Tivoli Storage Manager SBTAPI library. RMAN expects the SBT API library provided by a third party to be available as /oracle/ORC/102\_64/lib/libobk.a. Therefore, we have to create the following links:

```
ln -s /usr/tivoli/tsm/tdp_r3/ora/libtdp_r3.a /usr/lib/libobk.a
ln -s /usr/lib/libobk.a /oracle/ORC/102_64/lib/libobk.a
```

9. To instruct BR\*Tools to use RMAN as a backup interface, we modified the BR\*Tools configuration profile, as shown in Example 10-10 on page 283. The modifications are:
  - Parameter backup\_def\_type = rman\_util instructs BR\*Tools to allocate and use a dynamic RMAN channel instead of a BACKINT adapter.
  - RMAN channel features are specified by the parameter rman\_parms. BR\*Tools use the features specified by this parameter to dynamically allocate an RMAN channel. The RMAN channel will use SBTAPI of Tivoli

Storage Manager for ERP shown in step 8 on page 282. Use the following parameters:

<b>XINT_PROFILE</b>	The location of the Tivoli Storage Manager for ERP configuration file.
<b>PROLE_PORT</b>	The communication port of the ProLE process. This port is defined by the ProLE startup command (on the AIX operating system, it is located in <code>/etc/inittab</code> ). It typically reflected in <code>/etc/services</code> as port name <code>tdpr3ora</code> or <code>tdpr3ora64</code> .

The parameter `util_par_file` used for the BACKINT interface is still present in `init0RC.sap`, as shown in Example 10-10. Even though BR\*Tools will use RMAN for backup transfers to Tivoli Storage Manager server, it still uses BACKINT to back up BR\*Tools profiles and logs to the Tivoli Storage Manager server.

*Example 10-10 Tivoli Storage Manager for ERP - RMAN in init0RC.sap*

---

```
backup_mode = all
restore_mode = all
backup_type = online
backup_dev_type = rman_util
backup_root_dir = /oracle/ORC/sapbackup
stage_root_dir = /oracle/ORC/sapbackup
compress = no
compress_cmd = "compress -c $ > $"
uncompress_cmd = "uncompress -c $ > $"
compress_dir = /oracle/ORC/sapreorg
archive_function = save
archive_copy_dir = /oracle/ORC/saparch
archive_stage_dir = /oracle/ORC/saparch
tape_copy_cmd = cpio
disk_copy_cmd = copy
stage_copy_cmd = rcp
pipe_copy_cmd = rsh
cpio_flags = -ovB
cpio_in_flags = -iuvB
cpio_disk_flags = -pdcu
dd_flags = "obs=64k bs=64k"
dd_in_flags = "ibs=64k bs=64k"
saveset_members = 1
rman_parms =
"ENV=(XINT_PROFILE=/oracle/ORC/102_64/dbs/init0RC.utl,PROLE_PORT=5126,&
BR_INFO)"
```

```

copy_out_cmd = "dd ibs=8k obs=64k of=$"
copy_in_cmd = "dd ibs=64k obs=8k if=$"
rewind = "tctl -f $ rewind"
rewind_offline = "tctl -f $ offline"
tape_pos_cmd = "tctl -f $ fsf $"
tape_size = 100G
exec_parallel = 0
tape_address = /dev/rmt0.1
tape_address_rew = /dev/rmt0
volume_archive = (ORCA01, ORCA02, ORCA03, ORCA04, ORCA05,
                  ORCA06, ORCA07, ORCA08, ORCA09, ORCA10,
                  ORCA11, ORCA12, ORCA13, ORCA14, ORCA15,
                  ORCA16, ORCA17, ORCA18, ORCA19, ORCA20,
                  ORCA21, ORCA22, ORCA23, ORCA24, ORCA25,
                  ORCA26, ORCA27, ORCA28, ORCA29, ORCA30)
volume_backup = (ORCB01, ORCB02, ORCB03, ORCB04, ORCB05,
                 ORCB06, ORCB07, ORCB08, ORCB09, ORCB10,
                 ORCB11, ORCB12, ORCB13, ORCB14, ORCB15,
                 ORCB16, ORCB17, ORCB18, ORCB19, ORCB20,
                 ORCB21, ORCB22, ORCB23, ORCB24, ORCB25,
                 ORCB26, ORCB27, ORCB28, ORCB29, ORCB30)

expir_period = 30
tape_use_count = 100
util_par_file = /oracle/ORC/102_64/dbs/initORC.utl

```

---

During the configuration, you should consider the following parameters of Tivoli Storage Manager for ERP profile:

- |                        |   |
|------------------------|---|
| <b>backup_type</b>     | Identifies the default type of the database backup. This parameter is only used by BRBACKUP (the default is offline).   |
| <b>backup_dev_type</b> | Determines the backup medium that will be used (the default is tape). In order to use the backint interface, this parameter must be set either to util_file or util_file_online (see Table 10-4 on page 285). For RMAN, this parameter is set to rman_util. |
| <b>util_par_file</b>   | This parameter specifies where the parameter file, which is required for a backup with an external backup program, is located.  |
| <b>rman_parms</b>      | When backup_dev_type is set to rman_util, this parameter defines various parameters required for RMAN channel allocation.   |



To understand the possible combinations of backup\_dev\_type and backup\_type, refer to Table 10-4.

Table 10-4 BR\*Tools profile parameter options

Operation	backup_dev_type	backup_type
Offline backup	util_file	offline
Online backup	util_file	online
Online backup with individual tablespace locking	util_file_online	online
Online backup via RMAN	rman_util	online

### 10.4.3 Scheduling configuration

We use Tivoli Storage Manager scheduling to schedule repeating backup tasks. We define a schedule that backs up Oracle redo log files for ORC instance every 2 hours. The backed up redo logs are deleted from the local archivelog directory. We also schedule a daily full online backup of this database. All the schedules are defined centrally on the Tivoli Storage Manager server. The Tivoli Storage Manager client scheduler executes backup scripts on the client node on behalf the Tivoli Storage Manager server scheduler.

#### Schedule configuration on Tivoli Storage Manager server

We perform the following tasks on the Tivoli Storage Manager server:

1. We define two client schedules, SAP\_FULL\_ON and SAP\_LOGS, in the FSBACKUPS domain. Both schedules will be triggered within 10 minutes of the defined schedule start (duration=10 duru=min).
  - Schedule SAP\_FULL\_ON is triggered daily at 10 p.m. (startt, period, peru). SAP\_FULL\_ON performs full online backup by executing /tsm/scripts/br\_full\_on.ksh at the client node. The definition is shown in Example 10-11.

*Example 10-11 Client schedule SAP\_FULL\_ON*

---

```
TSM1>define schedule FSBACKUPS SAP_FULL_ON action=command
object="/tsm/scripts/br_full_on.ksh" startt=22:00 period=1 peru=day
duration=10 duru=min
```

---

- Schedule SAP\_LOGS is triggered every 2 hours. SAP\_LOGS performs a backup of offline redo logs by executing the `/tsm/scripts/br_logs_on.ksh` script at the client node. The definition is shown in Example 10-12.

*Example 10-12 Client schedule SAP\_LOGS*

---

```
TSM1>define schedule FSBACKUPS SAP_LOGS action=command
object="/tsm/scripts/br_logs_on.ksh" startt=21:30 period=2 peru=hour
duration=10 duru=min
```

---

2. To activate the SAP\_FULL\_ON and SAP\_LOGS schedules for the Tivoli Storage Manager node `charger01_fs`, we must link both schedules with Tivoli Storage Manager node. This is achieved by defining schedule associations, as shown in Example 10-13.

*Example 10-13 Definition of schedule associations*

---

```
TSM1>define association FSBACKUPS SAP_FULL_ON charger01_fs
TSM1>define association FSBACKUPS SAP_LOGS charger01_fs
```

---

## Schedule configuration on SAP database server

On the SAP database server, perform the following tasks:

1. To instruct the Tivoli Storage Manager client scheduler to authenticate with Tivoli Storage Manager server as node `charger01_fs`, we create the option file `/usr/tivoli/tsm/client/ba/bin/dsm.opt`. This file contains the line `SErvername TSM1_FS`. `SErvername` references the appropriate stanza in the `dsm.sys` file.
2. We adjust the root user's profile by adding Tivoli Storage Manager client variables `DSM_DIR`, `DSM_LOG`, and `DSM_CONFIG`, as shown in Example 10-14.

*Example 10-14 Lines added to .profile of the root user*

---

```
export DSM_DIR=/usr/tivoli/tsm/client/ba/bin
export DSM_CONFIG=/usr/tivoli/tsm/client/ba/bin/dsm.opt
export DSM_LOG=/var/log/tsm
```

---

The parameter `DSM_CONFIG` instructs Tivoli Storage Manager client scheduler to use `/usr/tivoli/tsm/client/ba/bin/dsm.opt` as the default option file. Tivoli Storage Manager client scheduler looks for the directory specified by `DSM_DIR` for the `dsm.sys` file. We have our `dsm.sys` in `/usr/tivoli/tsm/client/ba/bin`, which is just a symbolic link pointing to `/usr/tivoli/tsm/client/api/bin64/dsm.sys`.

3. We test the configuration of Tivoli Storage Manager scheduler by executing the `dsmc sched` command. The result is shown in Example 10-15.

*Example 10-15 Tivoli Storage Manager client scheduler*

---

```
# dsmc sched
IBM Tivoli Storage Manager
Command Line Backup/Archive Client Interface
  Client Version 5, Release 5, Level 0.0
  Client date/time: 09/29/08 14:22:14
(c) Copyright by IBM Corporation and other(s) 1990, 2007. All Rights
Reserved.

TSM Backup-Archive Client Version 5, Release 5, Level 0.0
Querying server for next scheduled event.
Node Name: CHARGER01_FS
Please enter your user id <CHARGER01_FS>:

Please enter password for user id "CHARGER01_FS":

Session established with server TSM: AIX-RS/6000
  Server Version 5, Release 5, Level 0.0
  Server date/time: 09/29/08 14:21:18 Last access: 09/29/08
14:21:18

Next operation scheduled:
-----
Schedule Name:      SAP_LOGS
Action:             Command
Objects:            /tsm/scripts/br_logs_on.ksh
Options:
Server Window Start: 21:30:00 on 09/29/08
-----
Schedule will be refreshed in 7 hours and 9 minutes.
```

---

4. We modify `/etc/inittab` to start the Tivoli Storage Manager client scheduler automatically during the AIX operating system startup. Example 10-16 shows the added line.

*Example 10-16 Startup of client scheduler in `/etc/inittab`*

---

```
tsmsched:2345:respawn:/usr/tivoli/tsm/client/ba/bin/dsmc sched
>/dev/null 2>&1
```

---

5. We copied backup scripts to the `/tsm/scripts` directory. The return code of the scripts reflects the result of the backup operation. The **brbackup** or **brarchive** commands are called with the BR\*Tools profile specified by parameter `-p`. Tivoli Storage Manager scheduler considers `RC=0` a successful

result. If another value is returned by the script, the scheduled event is considered to have failed.

- The script `br_full_on.ksh` found in Example 10-17 is responsible for executing a full online backup using BR\*Tools.

*Example 10-17 Tivoli Storage Manager backup script /tsm/scripts/br\_full\_on.ksh*

---

```
#!/bin/ksh
RC=0
su - oraorc <<EOB
brbackup -c -u / -t ONLINE_CONS -m FULL -p /oracle/ORC/102_64/dbs/initORC.sap
EOB
RC=$?
echo "\n\n$0 finished RC=$RC \n"
return $RC
```

---

- The script `br_logs_on.ksh` found in Example 10-18 is responsible for executing a backup of offline redo log files. The log files that have been successfully sent to Tivoli Storage Manager server are deleted from the local storage by using the parameter `-sd`.

*Example 10-18 Offline redo logs backup script /tsm/scripts/br\_logs\_on.ksh*

---

```
#!/bin/ksh
RC=0
su - oraorc <<EOB
brarchive -c -u / -sd -p /oracle/ORC/102_64/dbs/initORC.sap
EOB
RC=$?
echo "\n\n$0 finished RC=$RC \n"
return $RC
```

---

## 10.5 Configuration of BR\*Tools with the BACKINT interface

To reconfigure BR\*Tools to use BACKINT instead of Oracle RMAN, we keep most of our environment shown in 10.4, “BR\*Tools with Oracle RMAN configuration” on page 278. We perform a minor change to the BR\*Tools profile on the SAP server. We instruct BR\*Tools to call BACKINT instead of Oracle RMAN. We modify the parameter `backup_dev_type = util_file_online` in the `initORC.sap` file, as shown in Example 10-19, which enables an online backup with individual tablespace locking.

```
backup_mode = all
restore_mode = all
backup_type = online
backup_dev_type = util_file_online
backup_root_dir = /oracle/ORC/sapbackup
stage_root_dir = /oracle/ORC/sapbackup
compress = no
compress_cmd = "compress -c $ > $"
uncompress_cmd = "uncompress -c $ > $"
compress_dir = /oracle/ORC/sapreorg
archive_function = save
archive_copy_dir = /oracle/ORC/saparch
archive_stage_dir = /oracle/ORC/saparch
tape_copy_cmd = cpio
disk_copy_cmd = copy
stage_copy_cmd = rcp
pipe_copy_cmd = rsh
cpio_flags = -ovB
cpio_in_flags = -iuvB
cpio_disk_flags = -pdcu
dd_flags = "obs=64k bs=64k"
dd_in_flags = "ibs=64k bs=64k"
saveset_members = 1
#rman_parms =
"ENV=(XINT_PROFILE=/oracle/ORC/102_64/dbs/initORC.utl,PROLE_PORT=5126,&
BR_INFO)"
copy_out_cmd = "dd ibs=8k obs=64k of=$"
copy_in_cmd = "dd ibs=64k obs=8k if=$"
rewind = "tctl -f $ rewind"
rewind_offline = "tctl -f $ offline"
tape_pos_cmd = "tctl -f $ fsf $"
tape_size = 100G
exec_parallel = 0
tape_address = /dev/rmt0.1
tape_address_rew = /dev/rmt0
volume_archive = (ORCA01, ORCA02, ORCA03, ORCA04, ORCA05,
                  ORCA06, ORCA07, ORCA08, ORCA09, ORCA10,
                  ORCA11, ORCA12, ORCA13, ORCA14, ORCA15,
                  ORCA16, ORCA17, ORCA18, ORCA19, ORCA20,
                  ORCA21, ORCA22, ORCA23, ORCA24, ORCA25,
                  ORCA26, ORCA27, ORCA28, ORCA29, ORCA30)
volume_backup = (ORCB01, ORCB02, ORCB03, ORCB04, ORCB05,
                 ORCB06, ORCB07, ORCB08, ORCB09, ORCB10,
```

```
ORCB11, ORCB12, ORCB13, ORCB14, ORCB15,  
ORCB16, ORCB17, ORCB18, ORCB19, ORCB20,  
ORCB21, ORCB22, ORCB23, ORCB24, ORCB25,  
ORCB26, ORCB27, ORCB28, ORCB29, ORCB30)  
expir_period = 30  
tape_use_count = 100  
util_par_file = /oracle/ORC/102_64/dbs/initORC.utl
```

---

The changes in the backup method do not affect the schedules that we define in 10.4.3, “Scheduling configuration” on page 285.

## 10.6 References

Refer to the following books for more information about the topics covered in this chapter:

- ▶ *Data Protection for SAP - Installation and User's Guide for Oracle*, SC33-6340
- ▶ *IBM Tivoli Storage Management Concepts*, SG24-4877

# LAN-free backup and restore

This chapter describes an overview of the LAN-free backup and recovery methodology. The following topics are described:

- ▶ 11.1, “LAN-free backup and restore” on page 292
- ▶ 11.2, “Installation” on page 293
- ▶ 11.3, “Setup and configuration of storage agent” on page 302
- ▶ 11.4, “Setup and configuration for DB2 environment” on page 307
- ▶ 11.5, “Setup and configuration in Oracle environment” on page 316

## 11.1 LAN-free backup and restore

LAN-free backup and restore means that you do not have to have the data flow through the ordinary LAN network. Instead, data is copied directly to and from a Storage Area Network (SAN). Although there is still some control data that is transferred through the LAN, this method alleviates the bandwidth requirement for data protection that would normally flood your corporate network.

The main reasons to use LAN-free backup and restore are:

- ▶ To back up large databases (greater than 200 GB)
- ▶ To take CPU load off the Tivoli Storage Manager server
- ▶ To take the network load off the Local Area Network (LAN)
- ▶ To reduce backup windows for database servers and instances

The LAN-free solution needs additional hardware and software to be installed on the database server of the SAP system.

On the hardware side, at least one additional Fibre Channel adapter is required. We do not recommend having disk and tape assigned on the same Fibre Channel adapter, as this could cause performance issues with the server. The Fibre Channel adapter enables direct communication between the database server and the disk and tape libraries for sending data files through SAN. In a production environment, two Fibre Channel adapters for disk traffic and at least one Fibre Channel adapter for tape traffic are the recommended setup for redundant SAN communication.

Additional required software includes:

- ▶ Atape driver

The Atape driver enables the database server to connect directly to the tape drives or devices in the SAN infrastructure.

- ▶ Storage agent

The storage agent allows LAN-based communication to enable meta data to be sent to the Tivoli Storage Manager server.



## 11.2 Installation

The installation procedure covers:

- ▶ 11.2.1, “Atape driver installation” on page 293
- ▶ 11.2.2, “Storage agent installation” on page 296
- ▶ 11.2.3, “Configuration worksheets” on page 299

### 11.2.1 Atape driver installation

The IBM AIX Enhanced Tape and Medium Changer Device Driver is designed specifically to take advantage of the features provided by IBM tape drives and medium changer devices. The goal is to give applications access to the functions required for basic tape operations (such as backup and restore) and medium changer operations (such as mount and demount the cartridges), as well as to the advanced functions needed by full tape management systems. Whenever possible, the driver is designed to take advantage of the device features transparent to the application.

Note that some independent software vendor (ISV) applications have certain device driver requirements. Before you install the device drivers, refer to the ISV’s Web site or contact their support to discover what device drivers should be used for the ISV.

The AIX Enhanced Device Driver (Atape device driver) supports AIX 5L Version 5.2 and later releases on IBM POWER-based AIX servers.

Figure 11-1 describes the data flow using the Atape driver between the application program and the tape device.

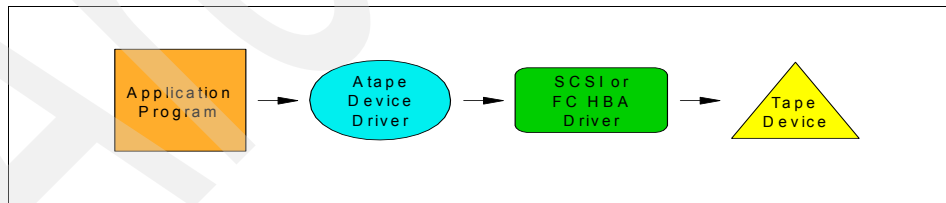

Figure 11-1 Data flow using an Atape driver

For more information, go to the following address:

[ftp://ftp.software.ibm.com/storage/devdrv/Doc/IBM\\_Tape\\_Driver\\_IUG.pdf](ftp://ftp.software.ibm.com/storage/devdrv/Doc/IBM_Tape_Driver_IUG.pdf)

## Preinstallation considerations

Before proceeding with the installation, verify the following items:

- ▶ The tape device is properly functioning, properly attached to the server, and is powered up. If you are attaching an IBM TotalStorage Enterprise Tape System 3590 Model E or Model H Tape Drive with the Fibre Channel Attachment, make sure it is defined with the hard addressing option.
- ▶ You have logged onto the server using an account with root authority.
- ▶ You have a command shell window open on the server to perform the installation procedure.
- ▶ Make sure the current path is defined in the command shell PATH variable. This can be accomplished in the korn shell using the following command:  

```
export PATH=.:$PATH
```
- ▶ If the tape device was configured previously by another device driver (not Atape), remove any existing device definitions for it. For example, run the command `rmdev -l ost1 -d`.

**Note:** The Atape driver will come in the format `Atape.x.x.x.x.bin`, where `x.x.x.x` is the version number of the Atape device driver.

## Installation and configuration instructions

The recommended procedure for installing a new version of the device driver is to uninstall the previous version.

At the end of the installation procedure, the `installp` facility will automatically run the AIX `bosboot` command to update the boot record with the newly installed Atape files. When the `bosboot` command completes, the message in Example 11-1 is displayed.

*Example 11-1 Bosboot command result*

---

```
0503-292 This update will not fully take effect until after a system
reboot. installp: bosboot process completed.
```

---

This message refers to the updates to the boot record only. If the installation summary shows that the Atape driver was installed successfully, it is *not* necessary to reboot the machine at this time.

If the installation summary shows that the install failed, you should correct the error, reboot the machine, and attempt to install the Atape driver a second time.

## Installation procedure

Enter the following command to list the currently installed Atape.driver version:

```
lslpp -l Atape.driver
```

To install the Atape driver in the current directory, use the **smi t** command. This will install and commit the Atape driver on the system. Verify that the installation is similar to what is shown in Example 11-2.

### *Example 11-2 Verification of Atape driver installation*

---

```
# lslpp -l Atape.driver
  Fileset                                Level  State      Description
-----
Path: /usr/lib/objrepos
  Atape.driver                          11.2.0.0 COMMITTED  IBM AIX Enhanced Tape
and Medium Changer Device Driver
```

---

Once the installation of the Atape driver has completed successfully, run the **cfgmgr** command to allow AIX to pick up the new devices. Verify the tape devices, as shown in Example 11-3.

### *Example 11-3 Verification of tape devices attached to server using SAN*

---

```
# lsdev -Cc tape
rmt0 Available 07-08-02 Other FC SCSI Tape Drive
rmt1 Available 07-08-02 Other FC SCSI Tape Drive
rmt2 Available 07-08-02 Other FC SCSI Tape Drive
```

---

## Uninstalling

When uninstalling, all devices that use the Atape driver must be closed and cannot be in use when Atape is uninstalled or the uninstall will fail. You can uninstall the Atape device driver using the **smi t** command menu to uninstall the software. Verify the uninstallation, as shown in Example 11-4.

### *Example 11-4 Verification of Atape driver deinstallation*

---

```
# lslpp -l Atape.driver
lslpp: 0504-132 Fileset Atape.driver not installed.
[root@desmoines01] /
```

---

## Accessing documentation and software online

IBM maintains the latest levels of TotalStorage tape drive and library device drivers and documentation on the Internet. The Web page has links to the device driver download Web pages. Obtain them by going to the following address:

<ftp://ftp.software.ibm.com/storage/devdrv/tapedrivers.html>

Information concerning supported Fibre Channel host bus adapters (HBAs) and associated HBA device drivers, firmware, and BIOS levels can be obtained by going to the following address:

<http://www-03.ibm.com/systems/support/storage/config/hba/index.wss>

You may also browse the FTP site and download drivers by going to one of the following addresses:

<ftp://ftp.software.ibm.com/storage/devdrv/AIX>

<ftp://207.25.253.26/storage/devdrv>

For further information, go to the IBM Support Web site for AIX Device Drivers for System Storage Tape at the following address:

<http://www-01.ibm.com/support/docview.wss?rs=543&tc=STCVQ6R&uid=ssg1S400093>

### 11.2.2 Storage agent installation

IBM Tivoli Storage Manager for Storage Area Networks is a feature of Tivoli Storage Manager that enables LAN-free client data movement. It provides a module called the storage agent. This feature allows the client system to directly write data to, or read data from, storage devices attached to a storage area network (SAN). Data movement is thereby off-loaded from the LAN and from the Tivoli Storage Manager server, making network bandwidth available for other uses. For example, using the SAN for client data movement decreases the load on the Tivoli Storage Manager server and allows it to support a greater number of concurrent client connections. Figure 11-2 on page 297 describes the data movement when using LAN-free.

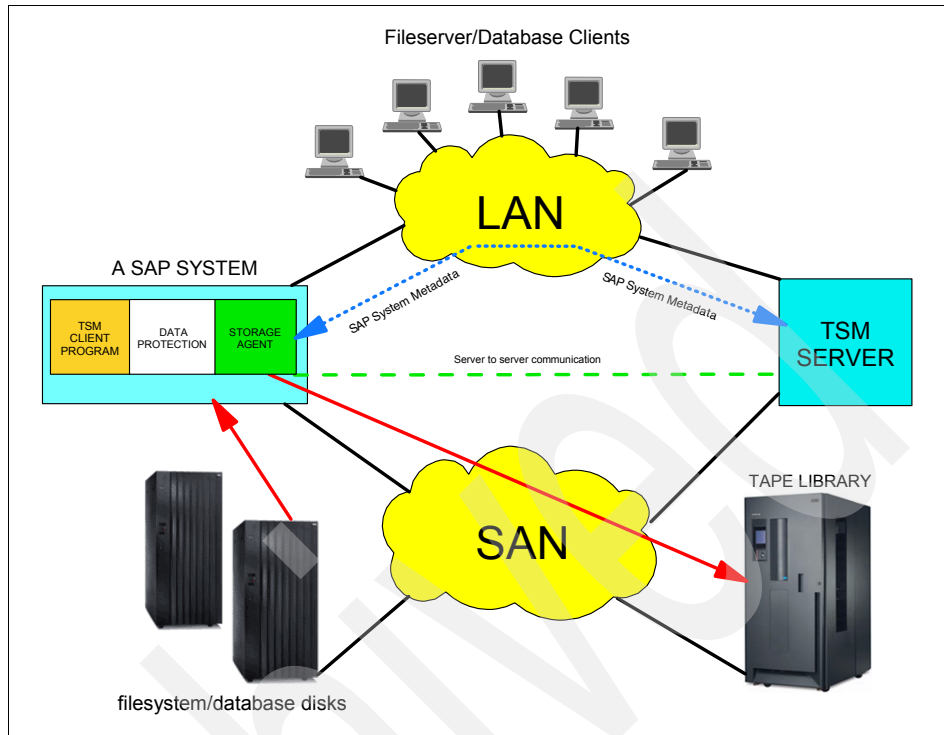

Figure 11-2 Data movement when using LAN-free

The storage agent can support several clients while installed on only one of the clients. You can install the storage agent on a client machine that shares storage resources with the Tivoli Storage Manager server or on a client machine that does not share storage resources but is connected to a client machine that does share storage resources with the Tivoli Storage Manager server. You must specify the LANFREECOMMMETHOD option in the `dsm.sys` client system options file to allow the client machine that shares storage resources to communicate with the storage agent. A Tivoli Storage Manager server, acting as a library manager, controls the storage devices. This server may be the server working in conjunction with the storage agent or another Tivoli Storage Manager server in the enterprise. The Tivoli Storage Manager server keeps track of the meta data that the client has stored. The meta data, such as policy information and file name and size, is passed over the LAN connection between the storage agent and server.

The storage agent communicates with the server to obtain and store database information and to coordinate device and volume access. The server and client coordinate and negotiate data access through the SAN. The client will use the storage agent for operations where appropriate. For example, if a SAN path is defined, the client (by means of the storage agent) transfers data on that path. If a failure occurs on the SAN path, failover occurs and the client uses its LAN connection to the Tivoli Storage Manager server and moves the client data over the LAN.

## System requirements and planning

To use LAN-free data movement, your SAN configuration must meet the applicable hardware and software requirements, which can be found at the following address:

<http://www.ibm.com/software/sysmgmt/products/support/IBMTivoliStorageManager.html>

TCP/IP is required for communication among the Tivoli Storage Manager server, the client, and the storage agent. An IBM Tivoli Storage Manager server has a license for LAN-free operations (Version 5.4 or later). To ensure compatibility between the server and the storage agent, check the Tivoli Web site for maintenance level requirements and download the latest Fix Pack level at the following address:

<http://www.ibm.com/software/sysmgmt/products/support/IBMTivoliStorageManager.html>

**Note:** The Tivoli Storage Manager server supports storage agents at the same version, release, and modification level, plus up to two modification levels earlier. Suppose that in the future IBM released Version 5.4.3 of the Tivoli Storage Manager server; it would support storage agents at the Version 5.4.3, Version 5.4.2, and Version 5.4.1 levels.

This compatibility is subject to change at the discretion of IBM. Review the readme file for a given server level for the latest information related to compatibility. Tivoli Storage Manager Version 5.4.0 servers will also support Version 5.3.4 and Version 5.3.5 storage agents.

## Installation procedure

To install the storage agent in the current directory, use the `smit` command menu. This installs and commits the storage agent on the system. Verify the installation by using the following procedure shown in Example 11-5 on page 299.

*Example 11-5 Verification of Storage Agent installation*

---

```
# lspp -l tivoli.tsm.StorageAgent.rte
Fileset                               Level State      Description
-----
Path: /usr/lib/objrepos
tivoli.tsm.StorageAgent.rte          5.5.0.0 COMMITTED IBM Tivoli Storage
Agent Runtime
```

---

### **Uninstalling**

When uninstalling, all devices that use the storage agent must be closed and cannot be in use when the storage agent is uninstalled or the uninstallation will fail. You can uninstall the storage agent using the **smit** command menu to uninstall software. Verify the uninstallation by using the command shown in Example 11-6.

*Example 11-6 Verification of storage agent deinstallation*

---

```
# lspp -l tivoli.tsm.StorageAgent.rte
lspp: 0504-132 Fileset tivoli.tsm.StorageAgent.rte not installed.
```

---

For more information, refer to *IBM Tivoli Storage Manager for SAN for AIX Storage Agent User's Guide Version 5.4*, SC32-0129 and the information found at the following address:

<http://publib.boulder.ibm.com/infocenter/tivihelp/v1r1/index.jsp?topic=/com.ibm.itsmagent.doc/anrlst5432.htm>

## **11.2.3 Configuration worksheets**

This section provides some configuration worksheet to assist you with a LAN-free backup and restore configuration. Use the worksheets in this section to record information about your client and server systems that you need when you install and configure the storage agent. Definitions for the terms in the worksheets are given in the worksheets.

Table 11-1 lists the client configuration information.

Table 11-1 Client system configuration information

<b>Storage agent properties</b>	
Enter information about the storage agent that you will need when you define the storage agent as a server to the Tivoli Storage Manager server.	
Name: Enter the name for the storage agent. For example, enter storagnt.	
Password: Enter the password for the storage agent. For example, enter fun4me.	
TCP/IP address: Enter the TCP/IP address for the storage agent. For example, enter agent.tucson.ibm.com.	
TCP/IP port: Enter the TCP/IP port of the client system.	
<b>Client options</b>	
LAN-free communications method (lanfreecommmethod client option): Circle the communications method you choose for the LAN-free data movement function. For more information, see the lanfreecommmethod option in the <i>IBM Tivoli Storage Manager for UNIX and Linux: Backup-Archive Clients Installation and User's Guide</i> , SC32-0145.	TCP/IP SharedMemory
LAN-free port (lanfreetcpport client option): Enter the TCP/IP port used for the LAN-free data movement function.	
<b>Device information</b>	
<b>External library</b>	
Executable location: Enter the fully qualified path to the external library manager executable for each storage agent to which Tivoli Storage Manager can send media access requests.	
Library name: Enter a name of your choosing that is less than or equal to 32 characters.	
<b>ACSLs, 3494, or SCSI drive device names</b>	
Enter the names of the tape drives for which you will define paths.	
Drive 1	
Drive 2	
Drive 3	
Drive 4	



Shared disk	
Local path name: Enter the name of the local path to the network-mounted file system. For example, enter /shareddisk.	

Table 11-2 contains the configuration information worksheet for the server systems.

Table 11-2 Server system configuration information

<b>Server properties</b>	
Enter information about the Tivoli Storage Manager server that the storage agent will need to communicate with the server. You can verify the server information by issuing the QUERY STATUS command from a Tivoli Storage Manager administrative command line.	
Name: Enter the name of the server. For example, enter tmsrver.	
Password: Enter the password for the server. For example, enter not4u.	
TCP/IP address: Enter the TCP/IP address for the server. For example, enter tmsrver.tucson.ibm.com.	
TCP/IP port: Enter the TCP/IP port for the server. For example, enter 1502.	
<b>Device information</b>	
<b>External library</b>	
Executable location: Enter the fully qualified path to the external library manager executable for each storage agent to which Tivoli Storage Manager can send media access requests.	
Library name: Enter a name of your choosing that is less than or equal to 32 characters.	
<b>ACSLs, 3494, or SCSI library information</b>	
Library name: Enter the name of an ACSLS, 3494, or SCSI library.	
Library device name: Enter the device name for an ACSLS, 3494, or SCSI library, which you will use when you define the path.	
<b>ACSLs, 3494, or SCSI drive device names</b>	
Enter the names of the tape drives for which you will define paths.	
Drive 1	
Drive 2	
Drive 3	

Drive 4	
Shared disk	
Local path name: Enter the name of the local path to the network-mounted file system. For example, enter /shareddisk.	
<b>Client node names</b>	
Record the names of the client nodes on which you will install and configure the storage agent. This information will be needed when you register the nodes, set the policy for them, and place any needed restrictions on them.	

Ensure that your tape library and drives are visible to the Tivoli Storage Manager server as well as to the client machine. You must create zones on your SAN to ensure visibility of these devices to the respective servers.

## 11.3 Setup and configuration of storage agent

The storage agent configuration is performed on both the storage agent machine, which acts as the Tivoli Storage Manager client, and the Tivoli Storage Manager server. The storage agent's default installation path is `/usr/tivoli/tsm/StorageAgent/bin`.

Figure 11-3 on page 303 describes how the different components interact with each other.

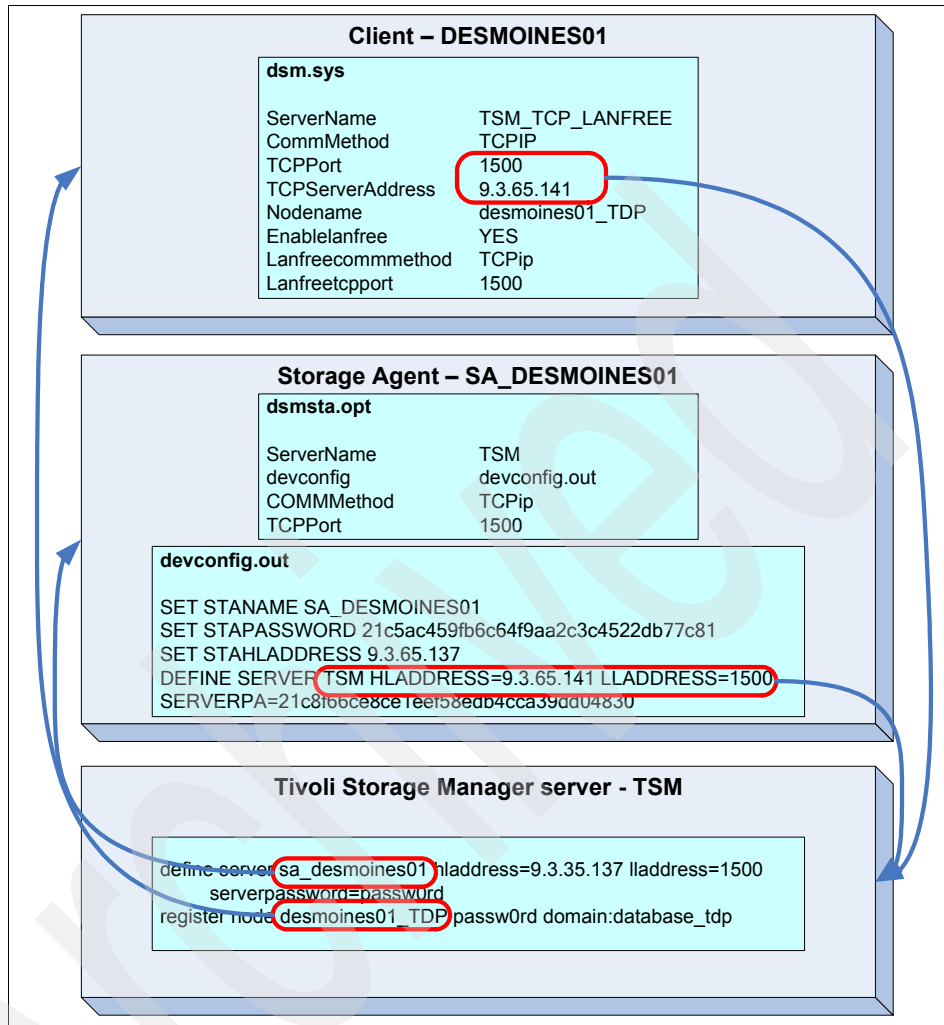

Figure 11-3 Summary of storage agent installation

The following are the configuration items we discuss in this section:

- ▶ 11.3.1, “Configuration on the Tivoli Storage Manager client” on page 304
- ▶ 11.3.2, “Configuration on the Tivoli Storage Manager server” on page 305

## 11.3.1 Configuration on the Tivoli Storage Manager client

Based on the configuration information worksheet in Table 11-1 on page 300, we start the configuration on a client level. In this book, we use the following settings:

- ▶ IP address of client machine = 9.3.65.137
- ▶ Node name of the client machine = DESMOINES01\_TDP
- ▶ Server name = TSM
- ▶ Tivoli Storage Manager Server password = passw0rd
- ▶ IP address of the Tivoli Storage Manager server = 9.3.65.141
- ▶ Tivoli Storage Manager server port = 1500

The configuration of the Tivoli Storage Manager client is as follows:

1. The client configuration for `dsmsta.opt` contains a reference to a device configuration file. This is referred from the `devconfig` parameter, as shown in Example 11-7.

*Example 11-7 Example of dsmsta.opt file*

---

TCPNODELAY	YES
TCPWindow size	63
TXNGroupmax	256
<b>SANDISCOVERY</b>	<b>ON</b>
<b>DEVCONFIG</b>	<b>/usr/tivoli/tsm/StorageAgent/bin/devconfig.txt</b>

---

2. You must run the `dsmsta setstorageserver` command, as shown in Example 11-8

**Note:** The command syntax is as follows:

```
DSMSTA SETSTORAGESERVER--MYName-----storage_agent_name--->
>--MYPAssword-----storage_agent_password----->
>--MYHLAddress-----storage_agent_hladdress----->
>--SERVERName-----server_name----->
>--SERVERPAssword-----server_password----->
>--HLAddress-----server_tcpip_address----->
>--LLAddress-----server_tcpip_port-----><
```

*Example 11-8 Example of setstorageserver command*

---

```
dsmsta setstorageserver myname=sa_desmoines01 mypassword=passw0rd
myhladdress=9.3.65.137 servername=TSM serverpassword=passw0rd
hladdress=9.3.65.141 lladdress=1500
```

---

3. The command in Example 11-8 on page 304 generates some information in the `devconfig.out` file, which is located in the `/usr/tivoli/tsm/StorageAgent/bin` directory. The command's output is similar to what is shown in Example 11-9.

*Example 11-9 Result of set storage server command in devconfig.out file*

---

```
SET STANAME SA_DESMOINES01
SET STAPASSWORD 21c5ac459fb6c64f9aa2c3c4522db77c81
SET STAHLADDRESS 9.3.65.137
DEFINE SERVER TSM HLADDRESS=9.3.65.141 LLADDRESS=1500
SERVERPA=21c8f66ce8ce1eef58edb4cca39dd04830
```

---

### 11.3.2 Configuration on the Tivoli Storage Manager server

Here are the configuration steps for the Tivoli Storage Manager server:

1. From the Tivoli Storage Manager administration client or command line, you must define the Storage Agent server to communicate to the Tivoli Storage Manager server, as shown in Example 11-10.

**Note:** When defining server to server communication, the syntax is as follows:

```
>>-DEFine--SERver--server_name--SERVERPAssword---password----->
>--HLAddress---ip_address--LLAddress---tcp_port----->
```

*Example 11-10 Example of defining server communication in Tivoli Storage Manager*

---

```
define server sa_desmoines01 serverpassword=passw0rd
hladdress=9.3.65.137 lladdress=1500
```

---

2. You must define paths from the storage agent to the drives on Tivoli Storage Manager. The drives must be zoned using SAN so that the client machine has direct access to it. You must check the defined tape drives on the storage agent by issuing the command shown in Example 11-11. The result of the command confirms that the drives have been zoned correctly.

*Example 11-11 List of defined tape drives on the storage agent*

---

```
# lsdev -Cc tape
rmt0 Available 07-08-02 Other FC SCSI Tape Drive
rmt1 Available 07-08-02 Other FC SCSI Tape Drive
rmt2 Available 07-08-02 Other FC SCSI Tape Drive
```

---

3. With the list of the defined tape drives, define the paths on the Tivoli Storage Manager Server, as shown in Example 11-12.

*Example 11-12 Example of defining a path in Tivoli Storage Manager*

---

```
define path sa_desmoines01 drv0 srct=server destt=drive library=1to1
device=/dev/rmt0
define path sa_desmoines01 drv1 srct=server destt=drive library=1to1
device=/dev/rmt1
define path sa_desmoines01 drv2 srct=server destt=drive library=1to1
device=/dev/rmt3
```

---

4. We start the Storage Agent from command line by issuing `dsmsta` for testing the connection to Tivoli Storage Manager server. The expected output is similar to Example 11-13.

*Example 11-13 Running storage agent*

---

```
# dsmsta
ANR7800I DSMSERV generated at 00:44:34 on Nov 6 2007.
Tivoli Storage Manager for AIX-RS/6000 Version 5, Release 5, Level 0.0
Licensed Materials - Property of IBM
(C) Copyright IBM Corporation 1990, 2007.
All rights reserved.
U.S. Government Users Restricted Rights - Use, duplication or disclosure
restricted by GSA ADP Schedule Contract with IBM Corporation.

ANR0900I Processing options file /usr/tivoli/tsm/StorageAgent/bin/dsmsta.opt.
ANR7811I Using instance directory /usr/tivoli/tsm/StorageAgent/bin.
ANR4726I The ICC support module has been loaded.
ANR8285I Shared Memory driver ready for connection with clients on port 1510
ANR0408I Session 1 started for server TSM1 (AIX-RS/6000) (Tcp/Ip) for storage
agent.
ANR0408I Session 2 started for server TSM1 (AIX-RS/6000) (Tcp/Ip) for library
sharing.
ANR9792E Library 3584 on library manager TSM1 is currently not being shared.
ANR0409I Session 2 ended for server TSM1 (AIX-RS/6000).
ANR0993I Server initialization complete.
ANR0916I TIVOLI STORAGE MANAGER distributed by Tivoli is now ready for use.
ANR0408I Session 3 started for server TSM1 (AIX-RS/6000) for event logging.
TSM:SA_DESMOINES01>
ANR8200I TCP/IP Version 4 driver ready for connection with clients on port 1500
```

---

5. We also test the connection from the Tivoli Storage Manager server. We list the sessions of server `sa_desmoines01`, as shown in Example 11-14 on page 307.

### Example 11-14 Listing sessions

```
tsm: TSM1>sa_desmoines01: q sess
ANR1699I Resolved SA_DESMOINES01 to 1 server(s) - issuing command Q SESS
against server(s).
ANR1687I Output for command 'Q SESS ' issued against server SA_DESMOINES01
follows:
```

Sess Number	Comm. Method	Sess State	Wait Time	Bytes Sent	Bytes Recvd	Sess Type	Platform	Client Name
1	Tcp/Ip	IdleW	0 S	2.2 K	2.8 K	Server	AIX-RS/6000	TSM1
3	Tcp/Ip	IdleW	0 S	1.6 K	253	Server	AIX-RS/6000	TSM1
4	Tcp/Ip	Run	0 S	167	234	Admin	AIX-RS/6000	ADMIN

```
ANR1688I Output for command 'Q SESS ' issued against server SA_DESMOINES01
completed.
ANR1694I Server SA_DESMOINES01 processed command 'Q SESS ' and completed
successfully.
ANR1697I Command 'Q SESS ' processed by 1 server(s): 1 successful, 0 with
warnings, and 0 with errors.
```

6. We edit `/etc/inittab` so that the storage agent is started during the AIX startup. We add the line shown in Example 11-15.

### Example 11-15 Storage Agent line in `/etc/inittab`

```
autostgagnt:2:once:/usr/tivoli/tsm/StorageAgent/bin/dsmsta quiet
>/dev/console 2>&1
```

7. If you want to start the storage agent manually from the `/usr/tivoli/tsm/StorageAgent/bin` directory, issue the command `nohup ./dsmsta quiet &`.

## 11.4 Setup and configuration for DB2 environment

The setup and configuration in a DB2 environment includes:

- ▶ 11.4.1, “Required Tivoli Storage Manager definitions” on page 308
- ▶ 11.4.2, “Tivoli Storage Manager API configuration” on page 310
- ▶ 11.4.3, “Tivoli Storage Manager for ERP configuration” on page 312

## 11.4.1 Required Tivoli Storage Manager definitions

For backups to execute properly, you must define the following on the Tivoli Storage Manager server:

- ▶ Management classes for backup and archives
- ▶ Backup copy groups and archive copy groups
- ▶ Tape device class and the respective storage pools

These items allow data to be transferred directly to tape or disk depending on the management class definitions.

**Note:** For the LAN-free option, you need to ensure that these management classes and copygroups point to the correct destination. Ideally, archive data should point to a disk pool and database data should point to a tape pool

In this case study, a brbackups management class is defined for backups to the tape storage pool, as shown in Example 11-16.

### *Example 11-16 Example of DBBACKUPS management class*

---

```
Policy Domain Name: DATABASE_TDP
    Policy Set Name: STANDARD
    Mgmt Class Name: DBBACKUPS
    Default Mgmt Class ?: Yes
    Description:
    Space Management Technique: None
    Auto-Migrate on Non-Use: 0
    Migration Requires Backup?: Yes
    Migration Destination: SPACEMGPOOL
Last Update by (administrator): ADMIN
    Last Update Date/Time: 09/19/08 14:48:24
    Managing profile:
    Changes Pending: No
```

---

A LOGS management class was defined for archiving logs to a disk storage pool, as shown in Example 11-17.

### *Example 11-17 Example of LOGS management class*

---

```
Policy Domain Name: DATABASE_TDP
    Policy Set Name: STANDARD
    Mgmt Class Name: LOGS
    Default Mgmt Class ?: No
    Description:
    Space Management Technique: None
```



Auto-Migrate on Non-Use: 0  
Migration Requires Backup?: Yes  
Migration Destination: SPACEMGPOOL  
Last Update by (administrator): ADMIN  
Last Update Date/Time: 09/19/08 14:48:30  
Managing profile:  
Changes Pending: No

---

The definition for the copy group for the DBBACKUPS management class is shown in Example 11-18.

*Example 11-18 Example of copy group for dbbackups management class*

---

Policy Domain Name: DATABASE\_TDP  
Policy Set Name: STANDARD  
Mgmt Class Name: DBBACKUPS  
Copy Group Name: STANDARD  
Copy Group Type: Archive  
Retain Version: No Limit  
Retention Initiation: Creation  
Retain Minimum Days:  
Copy Serialization: Shared Static  
Copy Frequency: CMD  
Copy Mode: Absolute  
Copy Destination: TAPEDATA  
Last Update by (administrator): ADMIN  
Last Update Date/Time: 09/19/08 14:49:48  
Managing profile:  
Changes Pending: No

---

The definition for the copy group for the LOGS management class is shown in Example 11-19.

*Example 11-19 Example of copy group for logs management class*

---

Policy Domain Name: DATABASE\_TDP  
Policy Set Name: STANDARD  
Mgmt Class Name: LOGS  
Copy Group Name: STANDARD  
Copy Group Type: Archive  
Retain Version: No Limit  
Retention Initiation: Creation  
Retain Minimum Days:  
Copy Serialization: Shared Static  
Copy Frequency: CMD

```

Copy Mode: Absolute
Copy Destination: DISKDATA
Last Update by (administrator): ADMIN
Last Update Date/Time: 09/19/08 14:50:00
Managing profile:
Changes Pending: No

```

---

## 11.4.2 Tivoli Storage Manager API configuration

The API configuration file resides in `/usr/tivoli/tsm/client/api/bin64`. The `dsm.sys` file must be edited. Change the `enablelanfree`, `lanfreecommmethod` and `lanfreetcpp` parameters, as shown in Example 11-20.

*Example 11-20 Example of dsm.sys*

---

```

*****
*
* Tivoli Storage Manager
*
*****
*
SErvername          TSM_TDP
COMMMethod         TCPip
TCPport            1500
TCPserveraddress   9.3.65.141
nodename           desmoines01_TDP
passwordaccess     generate
Compression        off
Txnb               2097152
Tcpcw              2048
Tcpcb              32
tcpnodelay         yes
errorlogname       /usr/tivoli/tsm/client/api/bin64/dsmerror.log
resour             8
ENABLELANFREE      yes
lanfreecommmethod tcpip
lanfreetcpp       1500

```

---

**Note:** The API client's `dsm.sys` is different than the one in the backup/archive client file. For the backup/archive client, `dsm.sys` resides in `/usr/tivoli/tsm/client/ba/bin`. You can keep both `dsm.sys` files synchronized by creating a symbolic link as follows:

```
ln -s /usr/tivoli/tsm/client/ba/bin/dsm.sys
/usr/tivoli/tsm/client/api/bin64/dsm.sys
```

When one `dsm.sys` file is updated, the other one is automatically updated as well. This can also be done for the `dsm.opt` files in both directories.

To back up databases using the Tivoli Storage Manager API, you must also make some changes in DB2. Perform the following steps:

1. Switch to the DB2 user by issuing the following command:

```
su - db2qas
```

2. Set the environment variables to include the following:

```
- DSMI_DIR=/usr/tivoli/tsm/client/api/bin64
- DSMI_CONFIG=/usr/tivoli/tsm/client/api/bin64/dsm.opt
- DSMI_LOG=/var/log/tsm
```

3. List the DB2 configuration by issuing the following command:

```
db2 get db cfg for QAS
```

4. You will see there is an option to add a Tivoli Storage Manager management class. You are required to add the management class that was defined for data to go straight to tape, as well as the management call for the archive logs. To configure this option, issue the following commands:

```
db2 update db cfg using TSM_MGMTCLASS DBBACKUPS
db2 update db cfg using LOGARCHMETH1 TSM:LOGS
```

**Note:** The `TSM_MGMTCLASS` option can be used to provide a temporary override for backup options.

5. Once this task is done, the database would have to be stopped and restarted. We recommend that you stop the database by stopping the SAP application. To do this task, you must log in as an administrative user (such as `qasadm`) and issue the **stopsap** command. This brings down the database. Otherwise, you can also issue the **db2stop** command to stop the database; if the database does not stop, use the **db2stop force** command.
6. Start the database. If you also stop SAP, you can start the instance using the **startsap** command. Otherwise, DB2 can be started using the **db2start** command.

7. Update the password for Tivoli Storage Manager using the **dsmapiw** command. You must run this command from the `/db2/db2qas/sql1lib/adsm` directory and issue the `./dsmapiw` command. See the execution result in Example 11-21.

*Example 11-21 dsmapiw results*

---

```
*****
* Tivoli Storage Manager                               *
* API Version = 5.5.0                                 *
*****
Enter your current password:
Enter your new password:
Enter your new password again:

Your new password has been accepted and updated.
```

---

### 11.4.3 Tivoli Storage Manager for ERP configuration

The Tivoli Data Protection for SAP configuration file resides in `/usr/tivoli/tsm/tdp_r3/db264`. The `dsm.sys` file must be edited to change the `enablelanfree`, `lanfreecommmethod` and `lanfreetcpp` parameters to what is shown in Example 11-22.

*Example 11-22 The dsm.sys file for Tivoli Storage Manager for ERP*

---

```
SErvername TSM_TDP
  COMMMethod      TCPip
  TCPPort         1500
  TCPServeraddress 9.3.65.141
  nodename        desmoines01_TDP
  passwordaccess  prompt
  TCPBuffsize     32
  TCPWindowSize   24
  Compression     Off
  errorlogname    /usr/tivoli/tsm/tdp_r3/db264/dsmerror_TDP.log
  ENABLELANFREE  yes
  lanfreecommmethod tcPIP
  lanfreetcpp     1500
```

---

Once this is done, the `<initSID>.ut1` file must be edited to point to the tape device management class so that data is transferred straight to tape. This file is located in `/db2/<SID>/tdp_r3`. A sample edited file is shown in Example 11-23 on page 313.

Example 11-23 Example of initQAS.utl

---

```
#-----  
#  
# Data Protection for SAP (R) interface for DB2 UDB  
#  
# Sample profile for Data Protection for SAP (R) Version 5.4  
#  
#-----  
# See the 'Data Protection for SAP (R) Installation &  
# User's Guide' for a full description.  
#  
# For a comment symbol the character '#' can be used.  
# Everything following this character will be interpreted as comment.  
#  
# Data Protection for SAP (R) accesses its profile  
# in "read only" mode. All variable parameters like passwords, date of  
# last password change, current version number will be written into the  
# file specified with the CONFIG_FILE parameter. The passwords will be  
# encrypted.  
#-----  
# Prefix of the 'Backup ID' which is used for communication with  
# the SAP-DB2 Administration Tools and stored in the description field  
# of the Tivoli Storage Manager archive function.  
# Maximum 6 characters.  
# Default: none.  
#-----  
BACKUPIDPREFIX      QAS____  
  
#-----  
# Number of parallel sessions to be established.  
# Note: This number must not exceed the number of tape drives  
# simultaneously available to the node on the Tivoli Storage Manager  
# servers to be accessed.  
# The valid range of MAX_SESSIONS is from 1 and 32.  
# Default: none.  
#-----  
MAX_SESSIONS        2 # Tivoli Storage Manager client sessions  
  
#-----  
# Number of backup copies of the DB2 log files.  
# The valid range of REDOLOG_COPIES is from 1 to 9.  
# Default: 1.  
#-----  
#REDOLOG_COPIES     2
```

```

#-----
# Specifies the block size for disk I/O (in bytes).
# The default values have been chosen from our performance experiments
# in standard hardware environments.
# The valid range of BUFFSIZE is from 4KB to 32MB.
# Default: 131072 (128 KB) on UNIX, 32768 (32 KB) on Windows.
#-----
BUFFSIZE          131072          # block size in bytes

#-----
# This optional parameter controls how Data Protection for SAP(R) uses
# the internal buffers for transferring data during a backup.
# Valid values:  SIMPLE | PREVENT | AUTO
# Default: SIMPLE
#-----
#BUFFCOPY          AUTO

#-----
# Name of a program to be called before the backup task is started.
# Default: none.
#-----
#FRONTEND          pgmname parameterlist

#-----
# Name of a program to be called after the backup task is completed.
# Default: none.
#-----
#BACKEND          pgmname parameterlist

#-----
# Maximum number of data base backup versions to be kept.
# Note: Version control by Data Protection for SAP (R) is only
# activated if the parameter MAX_VERSION is not 0.
# The valid range of MAX_VERSIONS is from 0 to 9999.
# A value of 0 means no versioning.
# Default: 0, no versioning.
#-----
#MAX_VERSIONS     4

#-----
# Specifies whether a null block compression of the data is to be
# performed before transmission to Tivoli Storage Manager.
# Although RL compression introduces additional CPU load, throughput
# can be improved when the network is the bottleneck. RL compression in

```

```

# Data Protection for SAP(R) should not be used together with
# Tivoli Storage Manager API compression.
# Default: NO
#-----
#RL_COMPRESSION          YES                # NO is default

#-----
# Controls generation of a trace file.
# Note: We recommend using the trace function only in cooperation with
# Data Protection for SAP (R) support.
# Default: OFF.
#-----
#TRACE                   OFF
#TRACEFILE               /db2/C21/sqllib/log/tdpr3.trace

#-----
# Denotes the maximum size of the trace file in KB.
# If not specified, the trace file size is unlimited.
#-----
#TRACEMAX               <max. size>        # trace file size in KB

#-----
# Specify the full path of the configuration file.
# Default: none.
#-----
CONFIG_FILE             /db2/QAS/tdp_r3/%DB2NODE/initQAS.bki

#-----
# Denotes if Data Protection for SAP (R) shall send error/status
# information to a Tivoli Storage Manager server.
# The servername must match one of the servers listed in a SERVER
# statement. Valid values for verbosity are ERROR | WARNING | DETAIL.
# Default: none.
#-----
#LOG_SERVER             servername        [verbosity]
#LOG_SERVER             server_a         ERROR

#*****
# Statement for servers and paths.
# Multiple servers may be defined.
#*****

SERVER                  TSM_TDP
SESSIONS                2                # Maximum number of sessions
                                # to server_a

```

```

PASSWORDREQUIRED YES # Use a password
ADSMNODE desmoines01_tdp
BRBACKUPMGTCCLASS dbbackups
BRARCHIVMGTCCLASS logs

#-----
# End of profile

END

```

---

## 11.5 Setup and configuration in Oracle environment

The API configuration file resides in /usr/tivoli/tsm/client/api/bin64. The dsm.sys file must be edited. Change the enablelanfree, lanfreecommmethod and lanfreetcpp parameters to what is shown in Example 11-24.

### *Example 11-24 Example of dsm.sys*

```

*****
*
* Tivoli Storage Manager
*
*****
SErvername server_a
  COMMMethod TCPip
  TCPPort 1500
  TCPServeraddress 9.3.65.141
  nodename charger01_tdp
  passwordaccess prompt
  Compression off
  Txnb 2097152
  Tcpw 2048
  Tcpb 32
  tcpnodelay yes
  errorlogname /usr/tivoli/tsm/client/api/bin64/dsmerror.log
  resour 8
  ENABLELANFREE yes
  lanfreecommmethod tcpip
  lanfreetcpp 1500

```

---



**Note:** The API client's `dsm.sys` is different than the one for the backup/archive client file. The backup/archive client's `dsm.sys` resides in `/usr/tivoli/tsm/client/ba/bin`. You can keep both `dsm.sys` files synchronized by creating a symbolic link as follows:

```
ln -s /usr/tivoli/tsm/client/ba/bin/dsm.sys  
/usr/tivoli/tsm/client/api/bin64/dsm.sys
```

When one `dsm.sys` file is updated, the other one is automatically updated as well. This can also be done for the `dsm.opt` files in both directories.

Archived

Archived

# FlashCopy backup and restore

FlashCopy allows a device to perform data replication to a backup storage without disrupting the operation of the device. FlashCopy is an attractive backup option, as it can be performed in the background without interrupting the operation of the application. The discussion in this chapter includes the following topics:

- ▶ 12.1, “Conventional FlashCopy method” on page 320
- ▶ 12.2, “Introduction Advanced Copy Services for SAP” on page 321
- ▶ 12.3, “Implement Advanced Copy Services for SAP in DB2” on page 329
- ▶ 12.4, “Implement Advanced Copy Services for SAP (Oracle)” on page 357
- ▶ 12.5, “FlashCopy cloning of SAP databases” on page 369

## 12.1 Conventional FlashCopy method

To perform a FlashCopy without Advanced Copy Services for SAP using an IBM System Storage DS8000 system, do these steps:

1. Identify the file systems that contain the database data files that you want to perform FlashCopy on. Ensure they belong to the Volume Groups you want to perform FlashCopy on. These file systems must be on a disk.
2. After creating the logical drives for the database host, you must create the FlashCopy logical drives for the target server or backup server.
3. Map the FlashCopy logical drives to the backup server and configure the host to see the drives. The backup server's logical drives should be the same size as the original drive from the source host for FlashCopy to work.
4. The LUNs of both the database and the backup servers must belong to their respective consistency groups on the storage box. The Consistency Group function of FlashCopy allows the DS6800 or DS8000 to hold off I/O activity to a LUN or volume until all LUNs/volumes within the group have established a FlashCopy relationship to their targets and the FlashCopy Consistency Group Created command is issued or a timer expires. Consistency Groups can be used to help create a consistent point-in-time copy across multiple LUNs or volumes, and even across multiple DS6800 systems, as well as across DS8000 series, ESS 800, and ESS 750 systems.
5. Put the database instance in offline mode or shut down the running instance.
6. Create a FlashCopy relationship using the **mkflash** command, as shown in Example 12-1.

*Example 12-1 FlashCopy relationship using mkflash*

---

```
dscli>mkflash -dev IBM.2107.75CMRY2 -freeze -record 0100:0300  
0101:0301 0102:0302
```

---

The parameters passed into the command are:

- |                |  |
|----------------|--|
| <b>-dev</b>    | Specifies the storage image ID, which consists of a manufacturer, machine type, and serial number. This parameter is required if you do not specify a fully qualified ID for the source and target volumes and you do not specify a value for the devid variable in your profile file. |
| <b>-freeze</b> | Triggers the queue full condition for the source volume. All writes to the source volume are queued by the host and are written after the queue full condition is reset. During the queue full condition, the source volume  |

reports long busy status. The queue full condition is reset by an extended long busy timeout condition. The timeout condition affects all FlashCopy source volumes that are contained within a respective logical subsystem and that are established or modified with the `-freeze` parameter.

**-record** Records the changed tracks on both volumes within a FlashCopy pair. Select this parameter when you establish an initial FlashCopy volume pair that you intend to use with the **resyncflash** command.

7. After you have established the FlashCopy relationship, you can resynchronize later changes made to the source volume using the **resyncflash** command, as shown in Example 12-2.

*Example 12-2 The resyncflash command*

---

```
dscli>resyncflash -dev IBM.2107.75CMRY2 -freeze -record 0100:0300  
0101:0301 0102:0302
```

---

8. You can run a **cfgmgr** command on the backup server to re-configure the disks and physical volume IDs and then do an **importvg** of the volume groups containing the FlashCopied disks, as shown in Example 12-3.

*Example 12-3 importvg of FlashCopy volumes on backup server*

---

```
importvg -y flashvg vpath1 vpath2 vpath3
```

---

## 12.2 Introduction Advanced Copy Services for SAP

IBM Tivoli Storage Manager for Advanced Copy Services for SAP provides nearly instant backup and recovery with a minimal impact on SAP system operation. The product exploits the snapshot capabilities of the underlying storage subsystems, such as IBM Total Storage Disk Storage, to provide instant backups and reduce exposure to data loss. It reduces the impact on the production environment by offloading data movement to alternate hosts and provides a single point of control in the distributed environment for all backup and restoration tasks to further simplify management and operations.

In this section, we describe different types of backup that are supported by Data Protection for FlashCopy as well as their recovery strategies. All backups that are performed by Data Protection for FlashCopy are full database backups. The transaction logs must be backed up separately by Data Protection for SAP.

The FlashCopy function itself has three options:

- ▶ FlashCopy with option copy
- ▶ FlashCopy with option incremental
- ▶ FlashCopy with option nocopy

In general, you can issue a backup and a restore of an SAP database using either the native backup utility, provided by the database application (available for DB2 only), Data Protection for SAP, or Data Protection for FlashCopy.

If you have installed Data Protection for FlashCopy, we recommend using it for all backup functions, even backups to the Tivoli Storage Manager server without FlashCopy. Each backup method has its own query function to list the backups made. If you have made backups to Tivoli Storage Manager using Data Protection for FlashCopy (as recommended), these backups are listed by queries from all methods.

Example 12-4 shows how a backup is listed in queries from DB2 after an offline backup of a DB2 SAP database from the production system to the Tivoli Storage Manager server has occurred. We use the **db2 list history backup all for QAS** command.

*Example 12-4 Listing all backup history from the QAS database*

---

Op	Obj	Timestamp+Sequence	Type	Dev	Earliest	Log	Current	Log	Backup	ID
B	D	20080919211839001	F	0	S0000037.LOG	S0000037.LOG				

---

Contains 26 tablespace(s):

00001 SYSCATSPACE  
00002 SYSTOOLSPACE  
00003 QAS#STABD  
00004 QAS#STABI  
00005 QAS#BTABD  
00006 QAS#BTABI  
00007 QAS#CLUD  
00008 QAS#CLUI  
00009 QAS#POOLD  
00010 QAS#POOLI  
00011 QAS#DDICD  
00012 QAS#DDICI  
00013 QAS#DOCUD  
00014 QAS#DOCUI  
00015 QAS#EL620D  
00016 QAS#EL620I  
00017 QAS#LOADD  
00018 QAS#LOADI

```
00019 QAS#PROTD
00020 QAS#PROTI
00021 QAS#ES620D
00022 QAS#ES620I
00023 QAS#SOURCED
00024 QAS#SOURCEI
00025 QAS#USER1D
00026 QAS#USER1I
```

---

```
Comment: DB2 BACKUP QAS OFFLINE
Start Time: 20080919211839
End Time: 20080919214057
Status: A
```

---

```
EID: 95 Location: /usr/tivoli/tsm/tdp_r3/db264/libtdpdb264.a
```

---

Example 12-5 shows how a backup is listed in Data Protection for SAP. We use the **backom -c q\_all -m detailed** command.

*Example 12-5 Listing a backup from Data Protection for SAP*

---

```
=====
Data Protection for SAP(R) - Backup Object Manager

-Version 5, Release 5, Modification 0 Level 0 for AIX LF 64-bit -
      Build: 316B compiled on Oct 23 2007
      (c) Copyright IBM Corporation, 1996, 2007, All Rights Reserved.
=====
===> Backup images for database 'QAS' <===

>> DATABASE BACKUP
Time: 20080919211839 Node: 0000 Session(s): 1 TDI: no
BID: QAS__AOEQ1N3XXQ Server: nashville01 Mgmt Class: DBBACKUPS
```

---

Example 12-6 shows how a backup is listed in Data Protection for FlashCopy. We use the `tdphdwb2 -f inquire -p ./desmoines01/initQAS.fcs` command.

*Example 12-6 Backup from Data Protection for FlashCopy*

---

```
IBM Tivoli Storage Manager for Advanced Copy Services
  Data Protection for FlashCopy Devices for mySAP(R) on DB2
    (tdphdwb2)

    FlashCopy Backup utility for IBM Tivoli Storage Manager
    - Version 5, Release 4, Level 2.0 for AIX (32 Bit) -
      Build: 354 generated at 00:38:32 on Jul 30 2008
    (c) Copyright IBM Corporation, 2000, 2007, All Rights Reserved.

IDS2014I 00023 BSI_TAPEONLY - 20080919211839 - 20080919211833 - -
exchange.00023
/db2/QAS/dbs/initQAS.utl :0000:20080919211839 -
:0000:/db2/QAS/log_dir/NODE0000/
FULL_OFFLINE :0000:S0000037.LOG - - - 531304 - - -
```

---

This chapter discusses Data Protection for FlashCopy, so we always use `tdbhdwb2` or `tdphdwb2` for backups and restores.

## 12.2.1 Backup to Tivoli Storage Manager server without FlashCopy

In this section, we back up SAP database only to the Tivoli Storage Manager server; there is no FlashCopy made.

### Backup

This type of backup can be initiated from Data Protection for FlashCopy, even though it will not make a FlashCopy. It must be initiated from the production server, because the backup server has no access to the database volumes. The backup can be either online or offline, and can be full or partial (for example, a single database). You might do this type of backup for migrating or moving a database (so that it is restored to another system), or in the event that the backup server is currently not available.

Data Protection for FlashCopy calls Data Protection for SAP to perform the backup and keeps track of that backup in the `IDS_CONTROL_FILE`.



## Restore

Restores are always initiated from the production server. In this scenario, even though the backup has to come from the Tivoli Storage Manager server, we can start the restore using Data Protection for FlashCopy program `tdphdwdb2` or `tdphdwora`.

### 12.2.2 Backup to Tivoli Storage Manager server from FlashCopy

In this scenario, we make a FlashCopy of the database, then back up the copied database to the Tivoli Storage Manager server.

#### Backup

Backing up the FlashCopied SAP database from the backup server to Tivoli Storage Manager using Data Protection for FlashCopy is the most common way of using the product.

Issuing `tdphdwdb2` or `brbackup` on the backup server will cause the server to contact the database server on the production side to gather information about the volumes where the database is located. The volume names are passed to `splitint`, which takes the names of the source volumes and puts them into the file `initQAS.fct` together with the target volumes. The FlashCopy copy is then started by `splitint` and, after a few seconds (when source and target volumes are connected), the backup of the SAP database to the Tivoli Storage Manager server will be started by Data Protection for my SAP on the backup server.

If both operations (FlashCopy and backup to Tivoli Storage Manager) finish without error, the target volumes are unmounted from the backup server.

#### Restore

In this case, because there are two backups made, you have the choice of restoring the SAP database from either the FlashCopy copy or from the backup on the Tivoli Storage Manager server. We refer to the restore from a FlashCopy copy as a *FlashBack restore*.

For a DB2 system, using `tdphdwdb2`, you will be guided through the restore and recovery process and you will be prompted for all required actions. For an Oracle SAP system using `tdphdwora`, you have to follow the product manual for pre- and post-restore activities.

**Note:** If you withdraw a target volume set, you can no longer use this set for a FlashBack restore, because the relationship is broken. The target volumes will be unmounted by default after the FlashCopy operation and the backup to the Tivoli Storage Manager server is complete. If the FlashCopy type is NOCOPY, the target volumes are also withdrawn, because this type of FlashBack is not eligible for a FlashBack restore.

### 12.2.3 Different options for the FlashCopy function

As mentioned before, there are three options for a FlashCopy copy:

▶ FlashCopy with option COPY

This makes a complete copy of the source volumes to the target volumes. This FlashCopy copy can be used for FlashBack restore.

▶ FlashCopy with option INCREMENTAL

The first time FlashCopy is run with the INCREMENTAL option, the source volumes will be copied to the target volumes. Subsequent FlashCopy INCREMENTAL operations will copy just the changes on the source volumes to the target volumes. You must make sure the target volumes are still associated with the source volumes, so no withdraw operation should be issued. This type of FlashCopy can be used for FlashBack restore as well. Incremental FlashCopy is not supported by the SAN Volume Controller.

▶ FlashCopy with option NOCOPY

This FlashCopy type is used for backup to the Tivoli Storage Manager server only. You cannot run a FlashBack restore from this backup, because only tracks that were changed while the backup of the SAP database is running are copied from the source volumes to the target volumes. A withdraw operation is performed by the process after the backup to Tivoli Storage Manager is complete.

### 12.2.4 Backup of offline transaction logs

On both DB2 and Oracle databases, we must perform a backup of the offline logs (also known as the archive logs). These logs are used for forward recovery after a restore of the database. These logs must be backed up from the production system. Currently, this function is not provided with Data Protection for FlashCopy.

**Note:** Each time you back up the SAP database, either online or using FlashCopy, make sure to save the transaction logs using the methods described here.

## DB2 logs

When the SAP software is using DB2 database, we have two methods to perform the backup of the offline log files:

- ▶ The SAP-DB2 Administration Tools include a utility called **brarchive**. This utility archives the offline logs to the Tivoli Storage Manager server and then deletes them from the logspace. A sample command is `/db2/<SID>/admintools/bin> brarchive -sd`.
- ▶ You can also use the DB2 **archive log** command. This is the recommended method. A sample command is `db2 archive log for database <SID>`.

The archival commands close the current log and mark it inactive. In an SAP environment, the LOGARCHMETH1 option of the DB2 configuration file has to be set to `VENDOR:<libraryname>` and the LOGARCHOPT1 option has to point to the Data Protection for SAP vendor environment file, `vendor.env`. This file is created by Data Protection for SAP at installation time and points to the `initSID.utl` file. You can see our settings for these variables in Example 12-7. Use the `db2 get db cfg for <SID> | grep LOGARCH` command to verify the proper settings.

*Example 12-7 Configuration settings for archiving logs*

---

```
db2qas> db2 get db cfg for QAS | grep LOGARCH
First log archive method (LOGARCHMETH1)           =
VENDOR:/usr/tivoli/tsm/tdp_r3/db264/libtdpdb264.a
Options for logarchmeth1 (LOGARCHOPT1)            =
/db2/QAS/dbs/vendor.env
Second log archive method (LOGARCHMETH2)          = OFF
Options for logarchmeth2 (LOGARCHOPT2)            =
```

---

These settings for LOGARCHMETH1 and LOGARCHOPT1 DB2 will automatically send offline logs to the VENDOR library, which is the Data Protection for SAP library.

## Oracle logs

When the SAP software is installed on the Oracle database, there is only one method available. Use the BR\*Tools **brarchive** utility to perform a backup of the offline log files. This utility calls Data Protection for SAP to perform the actual backup of the offline logfiles. The command is the same as for DB2.

## 12.2.5 Expiration consideration

Expiration of backups can be handled by:

- ▶ Tivoli Storage Manager server

The expiration of backup and archived objects is handled by expiration definitions in the active copy groups within the policy. Data Protection for SAP uses only the archive copy group. For archived objects (Data Protection for SAP stores all files in an archive storage pool), you have to set the option RETVer, which controls how long the objects will be kept. You can either set this value to an appropriate number of days for your environment, or set it to NOLIMIT, if you want Data Protection for SAP to control the expiration of SAP database backups.

- ▶ Data Protection for SAP

Data Protection for SAP handles the expiration using versioning. A version number is part of the description, which is part of the meta data sent for each archived object to the Tivoli Storage Manager server. This version number is incremented on each full backup, kept on the Tivoli Storage Manager server, and is maintained in the `initSID.bki` file. Use the `MAX_VERSIONS` option in the Data Protection for SAP profile `-init<SID>.utl` to set the number of versions of database backups that you want to keep on the Tivoli Storage Manager server. If you set `MAX_VERSIONS` to 0, then there will be no version control by Data Protection for SAP.

**Note:** If the Data Protection for SAP binary profile `init<SID>.bki` is deleted or replaced by an older version, the versioning will be invalidated. New full backups, sent to the Tivoli Storage Manager server, will have a lower version number than the older backup versions already stored, which means that older backup versions will not be deleted.

- ▶ Data Protection for FlashCopy

Data Protection for FlashCopy has the same option `MAX_VERSIONS` in the `initSID.bki` file, because it calls Data Protection for SAP to do the actual archive to the Tivoli Storage Manager server. Therefore, the `initSID.bki` file and the `initSID.utl` file must be accessible by both the production and backup server, which we achieve by keeping these files on the NFS shared volume. However, there is another option, `BACKUP_MAX`, defined in the Data Protection for FlashCopy profile `init<SID>.fcs`. Each entry in the `IDS_CONTROL_FILE` represents a backup cycle, even a failed one.

## 12.3 Implement Advanced Copy Services for SAP in DB2

This section discusses the installation and configuration steps to be performed for Data Protection for FlashCopy to work with SAP when using a DB2 database. We discuss the following topics:

- ▶ 12.3.1, “Data Protection for SAP (DB2) installation and configuration” on page 329
- ▶ 12.3.2, “Customizing the DB2 environment” on page 331
- ▶ 12.3.3, “Password handling methods” on page 332
- ▶ 12.3.4, “CIM installation and configuration” on page 333
- ▶ 12.3.5, “Data Protection for FlashCopy installation and configuration” on page 336
- ▶ 12.3.6, “Data Protection for FlashCopy configuration” on page 338
- ▶ 12.3.7, “Other prerequisites for the backup server” on page 343
- ▶ 12.3.8, “FlashBack restore” on page 355

### 12.3.1 Data Protection for SAP (DB2) installation and configuration

Before starting the installation of Data Protection for SAP on the production system, you should collect the following information, which will be required during the installation process:

- ▶ DB2 UDB database SID  
In our case, the SID name is QAS.
- ▶ Directory for Data Protection for SAP (DB2) configuration files  
Create the directory `dbs` in `/db2/<SID>` for configuration files. This will be mounted later on the backup server using NFS. Our configuration directory is `/db2/QAS/dbs`.
- ▶ Tivoli Storage Manager server  
The name must already exist in the API's `dsm.sys` file. This is the tag name used against `SERVERNAME` option in the `dsm.sys` file. We used the name `lincoln02` in our `dsm.sys` file.
- ▶ Tivoli Storage Manager node name  
Our Tivoli Storage Manager node name for keeping Data Protection for SAP (DB2) backups is `desmoines01_tdp`.

- ▶ Management class for database backups  
Our management class for keeping QAS instance database objects is dbbackups.
- ▶ Management classes for log file backups  
Our management class for keeping QAS instance log objects is logs.
- ▶ Network address of administration assistant server (Optional)  
We used a Windows machine with IP address 9.41.222.171 for our administration assistant server.
- ▶ Port for Administration Assistant Server (Optional)  
We used the default port used in the installation of TDP for ERP.

Figure 12-1 shows the lab environment.

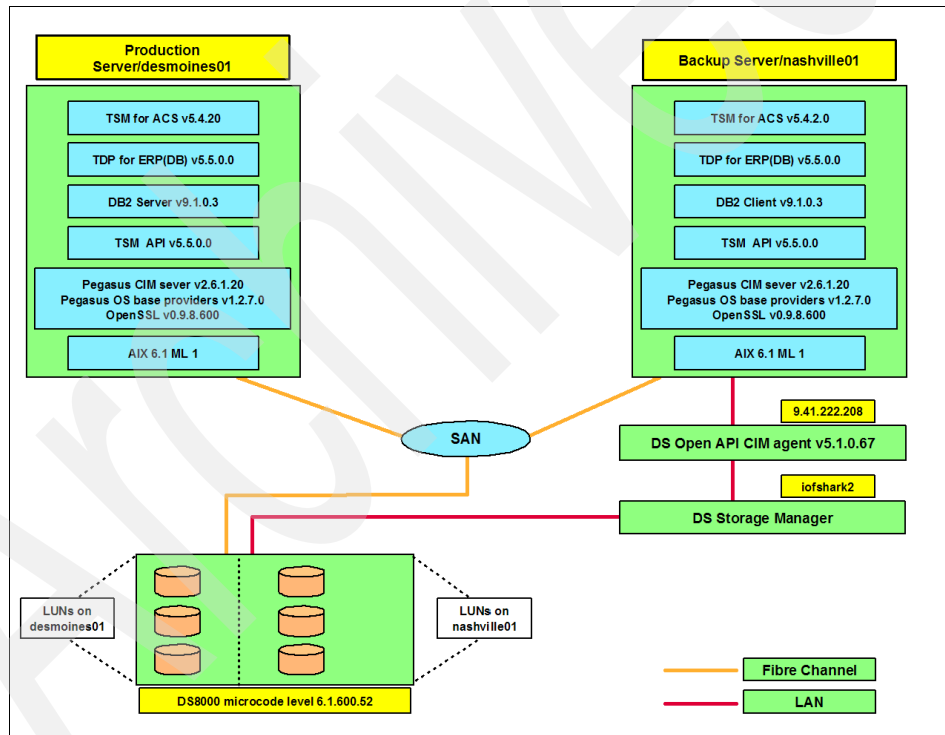

Figure 12-1 Advanced Copy Services for SAP (DB2) lab environment

## Installation on the production server

We use ASCII mode for installation, as shown in 9.6, “Tivoli Storage Manager for ERP-DB2 installation” on page 243. The code is installed in the `/usr/tivoli/tsm/tdp_r3/db264` directory, as we have a 64-bit system.

## Installation on the backup server

Follow the same procedure and use the same values as on the production server except for the following parameters, which are the The Data Protection for SAP (DB2) configuration files for the backup server that are specified in a dummy directory, such as `/tmp/tdpinstall`. We use a NFS mounted directory from the production server.

### 12.3.2 Customizing the DB2 environment

This section explains how to customize the DB2 environment on the production server. Environment variables are required in the login profile of the DB2 administrative user. Substitute the name of your SID in the `XINT_PROFILE` and `TDP_DIR` environment variables. Our `.profile` file for `db2qas` user is shown in Example 12-8.

#### *Example 12-8 Environment variables*

---

```
export XINT_PROFILE=/db2/QAS/dbs/initQAS.utl
export TDP_DIR=/db2/QAS/dbs/tdplog
export DB2_VENDOR_LIB=/usr/tivoli/tsm/tdp_r3/db264/libtdpdb264.a
```

---

The changes in Example 12-8 are for a 64-bit system. If you are using a 32-bit environment, the shared library is called `libtdpdb2.a` in directory `/usr/tivoli/tsm/tdp_r3/db2`.

The DB2 registry must be updated with a pointer to the vendor environment file. Use the command shown in Example 12-9.

#### *Example 12-9 DB2 registry update*

---

```
db2set DB2_VENDOR_INI=/db2/QAS/dbs/vendor.env
```

---

### 12.3.3 Password handling methods

You can choose to have the node password handled by Data Protection for SAP (DB2) or by the Tivoli Storage Manager client API. If you choose to manage the password with the Data Protection for SAP utility files, configuration is only required on the production system. However, if you decide to manage through client API, the system options file must be updated on both the production and backup server.

#### Password handled by Data Protection for SAP (DB2)

In this method, the password is stored in the Data Protection for SAP (DB2) binary configuration file `/db2/<SID>/dbs/init<SID>.bki`, which takes the configuration information from the utility file `init<SID>.utl`. The files are shared between the production and backup servers, so only the copy on the production server has to be updated. If the password expires in Tivoli Storage Manager, you must update the new password in Tivoli Storage Manager and configure the same in Data Protection for SAP (DB2).

This handling is specified in the `init<sid>.utl` file, as shown in Example 12-10.

*Example 12-10 Data Protection for SAP (DB2) utility file /db2/QAS/dbs/initQAS.utl*

---

```
PASSWORDREQUIRED YES  
ADSMNODE desmoines01_tdp
```

---

You also have to update the password using the `backom -c password` command on the production server.

#### Password handled by Tivoli Storage Manager API

In this method, the password is stored by the Tivoli Storage Manager API. If the password expires in the Tivoli Storage Manager server, the client API updates the password and stores the same. You do not have to change anything in Data Protection for SAP (DB2). The `/usr/tivoli/tsm/client/api/bin64/dsm.sys` option file is shown in Example 12-11.

*Example 12-11 Tivoli Storage Manager client API options file*

---

```
passwordaccess generate  
nodename desmoines01_tdp
```

---

Example 12-12 on page 333 shows the entries required in the Data Protection for SAP (DB2) utility file (`/db2/<SID>/dbs/init<SID>.utl`).



*Example 12-12 Data Protection for SAP (DB2) utility file /db2/QAS/dbs/initQAS.utl*

---

```
PASSWORDREQUIRED NO
# ADSMNODE desmoines01_tdp
```

---

## 12.3.4 CIM installation and configuration

This section explains the configuration and installation of CIM software and other requisites.

### OpenSSL installation

We use the non-SSL communication mode, but CIM client requires OpenSSL package for its operations. Open SSL can be downloaded from the AIX toolbox for Linux application page at the following address:

<http://www-03.ibm.com/systems/power/software/aix/linux/index.html>

You can check the availability of OpenSSL with the command shown in Example 12-13.

*Example 12-13 OpenSSL package*

---

```
# rpm -qa | grep -i openssl
openssl-0.9.71-2
```

---

You can install OpenSSL using the `rpm -ivh <OpenSSLrpmpackage>` command.

### Pegasus CIM software installation

Pegasus CIM software has both a server and a client part. However, Data Protection for FlashCopy uses only the CIM client libraries to interface with the CIM agent for the respective storage system. The client libraries are referred to as the CIM client in the Data Protection for FlashCopy environment. The Pegasus package must be installed in each server where Data Protection for FlashCopy is going to be installed. The CIM client requires the libssl.a library, which is part of the OpenSSL package. However, SSL should be disabled for Data Protection for FlashCopy environment. Pegasus software is available as part of the AIX Expansion Pack.

The required filesets are as follows:

- ▶ `sysmgt.pegasus.cimserver.rte`

This fileset is installed in the `/opt/freeware/cimom/pegasus` directory. It includes both the client and server components. However, we do not actually use the server component.

- ▶ `sysmgt.pegasus.osbaseproviders`

This fileset is installed in the `/usr/pegasus/provider` directory.

The software is in the installp format and can be installed using SMIT. No configuration is required on the CIM client.

## CIM agent installation

The DS Open API CIM agent installation is required only if an IBM ESS, DS8000, or DS6000 storage system is used. If the SAN Volume Controller (SVC) is used, the CIM agent is part of the SVC Master Console, so it does not have to be installed separately. The CIM agent can be installed on any server accessible by the production server, backup server, and the storage system. The CIM agent is a Java based application. We do not recommend running it on the production server, as it adds some additional processing load. If you already have a CIM agent, you do not have to install it again; you can use any existing CIM agent.

The DS Open API CIM Agent, as well as updates and other information, can be obtained at the following URL:

<http://www.ibm.com/servers/storage/support/software/cimdoapi/installing.html>

**Note:** If you use an ESS storage system, you must also install the command-line interface (CLI) for ESS before the CIM agent installation.

Make sure that the default value for the `DigestAuthentication` option is changed from `true` to `false` in the `cimom.properties` file. To make this change effective, the CIMOM has to be restarted, as shown in Example 12-14.

### *Example 12-14 CIMOM restart process*

---

```
C:\Program Files\IBM\cimagent>stopcimom.bat
The CIM Object Manager - DS Open API service is stopping.....
The CIM Object Manager - DS Open API service was stopped successfully.

C:\Program Files\IBM\cimagent>startcimom.bat
The CIM Object Manager - DS Open API service is starting...
The CIM Object Manager - DS Open API service was started successfully.
```

---

In our case, we installed the CIMOM on a Windows machine that was accessible over LAN to the DS8000 server, and the production and backup servers.

Our next step is to configure the storage devices, DS6000 or DS8000, within the CIM agent. Specify the IP address of the DS6000 or DS8000, and the user name and password with the **address** and **addressserver** commands. You can then view those settings using the **lsess** and **lsessserver** commands, as shown in Example 12-15.

*Example 12-15 CIM agent configuration*

---

```
C:\Program Files\IBM\cimagent>setdevice
Application setdevice started in interactive mode
To terminate the application enter: exit
To get a help message enter: help
>>> address 9.3.80.176 uptuser <password>
An ess provider entry for IP 9.3.80.176 successfully added
>>> addressserver 9.3.80.176 uptuser <password>
An essserver entry for IP 9.3.80.176 successfully added
>>> lsess
  IP          : USER      : ENCRYPTED PASSWORD
  9.3.80.176 : uptuser   : dkqhUMREFYIrXR4G
>>> lsessserver
  IP          : USER      : ENCRYPTED PASSWORD : IPA
  9.3.80.176 : uptuser   : bEq0TMvs03IFxf0L : NOT SET
```

---

You can also verify the CIM agent configuration using the **verifyconfig** command, as shown in Example 12-16.

*Example 12-16 Verify CIM agent configuration*

---

```
C:\Program Files\IBM\cimagent>verifyconfig.bat -u superuser -p <passwd>
Sat Sep 20 02:46:04 IST 2008
Verifying configuration of CIM agent for the IBM TotalStorage DS Open
Application Programming Interface...
Communicating with SLP to find WBEM services...
1 WBEM services found
  host=9.41.222.208, port=5988
Connecting to CIM agent, host=9.41.222.208, port=5988
Found 2 IBMTSESS_StorageSystem instances:
2107.75CMRY2
2107.75CMRY1
Internal Server at 9.3.80.176 configured for 2107.CMRY1
Internal Server at 9.3.80.176 configured for 2107.CMRY2
Verification Successful
```

---

**Note:** We have changed the password of the superuser user within CIM agent using the **setuser** and **chuser** commands.

## 12.3.5 Data Protection for FlashCopy installation and configuration

This section describes the installation and configuration of Data Protection for FlashCopy.

### Preparation

The rshd and rexecd daemons must be enabled on the production server, and you should refresh the inetd daemon if any changes were made to the inetd.conf file.

Ensure that the .rhosts file is created in the home directory of the DB2 user ID (db2qas in our configuration) to enable the rsh command to work from the backup server to the production server.

NFS exports the configuration directory /db2/QAS/dbs, as it is a common directory to keep all Data Protection for SAP (DB2) and Data Protection for FlashCopy configuration files, work directories, and log files so that the information is consistent across both the production and backup servers.

The environment variables INSTHOME, DB2DBDFT, DB2INSTANCE, DSM\_DIR, DSM\_CONFIG, DSM\_LOG, DSMI\_DIR, DSMI\_CONFIG and DSMI\_LOG must all be set.

### On production and backup server

The installation must be performed as the root user. We used ASCII mode to do the installation, as shown in Example 12-17.

*Example 12-17 ACS for SAP for DB2 installation*

---

```
# ./5.4.2.0-TIV-TSMACSSAPDDB2FTP-AIX.bin -console
```

```
    Initializing InstallShield Wizard.....
    Launching InstallShield Wizard.....
```

```
-----
Welcome to ...
IBM Tivoli Storage Manager for Advanced Copy Services
Data Protection for FlashCopy Devices for mySAP
```

```
This will install Data Protection for FlashCopy Devices for mySAP on
your computer.
```

```
Version 5.4.2.0.
```

```
Please visit our webpage:
```

```
http://www.ibm.com/software/tivoli
```

Press 1 for Next, 3 to Cancel or 5 to Redisplay [1] 1

-----  
IBM Licence Acceptance Panel

International Program License Agreement

. . .

Press Enter to continue viewing the license agreement, or, Enter "1" to accept the agreement, "2" to decline it or "99" to go back to the previous screen, "3" Print, "4" Read non-IBM terms.

1

Press 1 for Next, 2 for Previous, 3 to Cancel or 5 to Redisplay [1] 1

-----  
Data Protection for FlashCopy Devices for mySAP will be installed in the following location:

/usr/tivoli/tsm/acssap/db2

with the following features:

DB2\_AIX

for a total size:

70 MB

Press 1 for Next, 2 for Previous, 3 to Cancel or 5 to Redisplay [1] 1

Installing Data Protection for FlashCopy Devices for mySAP. Please wait...

|-----|-----|-----|-----|  
0%            25%            50%            75%            100%  
|||

Creating uninstaller...

Finalizing the Vital Product Data Registry. Please wait...

Please read the information below.

**ATTENTION!**

You have to execute the script `./setup.sh` once for each user who will run Data Protection for FlashCopy Devices for mySAP.

You will find the script `setup.sh` in the installation directory `/usr/tivoli/tsm/acssap/db2`.

Press 1 for Next, 2 for Previous, 3 to Cancel or 5 to Redisplay [1] 1

-----  
The InstallShield Wizard has successfully installed Data Protection for FlashCopy Devices for mySAP. Choose Finish to exit the wizard.

Press 3 to Finish or 5 to Redisplay [3] 3

---

### **Tivoli Storage Manager client options file configuration**

The script `setupDB2BS`, which must be executed later from the backup server, expects the Tivoli Storage Manager client options file to be available in the `/db2/<SID>/sqllib/adsm` directory. We created a link to the actual option file, as shown in Example 12-18. We run `setupDB2BS` in “Executing the `setupDB2BS` script” on page 343.

*Example 12-18 Create link to API client options file*

---

```
root@desmoines01: /> cd /db2/QAS/sqllib/adsm
root@desmoines01:/db2/QAS/sqllib/adsm> ln -sf
/usr/tivoli/tsm/client/api/bin64/dsm.opt dsm.opt
```

---

## **12.3.6 Data Protection for FlashCopy configuration**

This section describes the initialization and setup required on the production server

### **Executing the `setup.sh` script.**

After the Data Protection for FlashCopy code installation, execute the `setup.sh` script, which copies the configuration files to the correct location and name, and creates links to the Data Protection for FlashCopy executables. Run the script as the root user, as shown in Example 12-19 on page 339.

*Example 12-19 setup.sh script execution*

---

```
# /usr/tivoli/tsm/acssap/db2/setup.sh
Please enter the SAPSID for the Production SAP System: [C21] QAS
Please enter the DBSID for the Production SAP System: [QAS] QAS
DB2 UDB V9 found on this machine
checking DB2 Instance...OK
DB2 instance db2qas is a DB2 V9 instance
checking DB2 Instance Bit-Width...OK
DB2 instance db2qas is a 64 bit instance
checking DB2 Instance Type...OK
DB2 instance db2qas is a multiple partitions instance

Please enter the path for the configuration files: [/db2/QAS/dbs]
Please enter the path for the executables: [/db2/QAS/dbs]
reading db2nodes.cfg...OK
    single partition
    number of Servers      : 1
    list of Servers       : desmoines01
    max # Nodes per Server : 1

Is desmoines01 your [P]roduction or [B]ackup server ? [P/B] P
check/create directory /db2/QAS/dbs/desmoines01 ...
Free space in filesystem = 10109932 KB
Dirname = /db2/QAS/dbs
Space available = 10109932 KB, Required = 10000 KB
Free space in filesystem = 10109932 KB
Dirname = /db2/QAS/dbs
Space available = 10109932 KB, Required = 10000 KB
Free space in filesystem = 1419036 KB
Dirname = /usr/tivoli/tsm/acssap/db2
Space available = 1419036 KB, Required = 100000 KB

group dba exists with GID 211...
user db2qas exists in group dba...
/db2/QAS/dbs/desmoines01/initQAS.fcs already exists. Old .fcs will be kept.
/db2/QAS/dbs/desmoines01/initQAS.fct already exists. Old .fct will be kept.

checking TSM ACS mySAP socket server...

/db2/QAS/dbs/splitint already exists. Rename ? [Y/N] Y
creating acsprole TCPIP service port tsmacsdb2 57326/tcp...
acsprole TCPIP service port ->tsmacsdb2 57326/tcp <- already exists
waiting for TSM ACS mySAP acsprole to start.....OK
Setup successful.
```

---

## Customizing the Data Protection for FlashCopy profile

The Data Protection for FlashCopy profile /db2/QAS/dbs/desmoines01/initQAS.fcs has to be updated, as shown in Example 12-20. You must set the values for PRIMARY\_COPYSERVICES\_SERVERNAME, COPYSERVICES\_SERVERPORT, and COPYSERVICES\_USERNAME to correspond to the CIM agent setting for an ESS, DS6000, or DS8000 installation, or from the Master Console, if using a SAN Volume Controller. In all cases, make sure to use the http port, not the secure https port.

*Example 12-20 /db2/QAS/dbs/desmoines01/initQAS.fcs*

---

LOGON_HOST_PROD	desmoines01	db2qas
LOGON_HOST_BACK	nashville01	
BACKUP_MAX	30	
IDS_CONTROL_FILE	/db2/QAS/dbs/desmoines01/save/idssave	
CONFIG_FILE	/db2/QAS/dbs/desmoines01/initQAS.fcp	
WORK_DIR	/db2/QAS/dbs/desmoines01/work	
TRACE	YES	
LOG_TRACE_DIR	/db2/QAS/dbs/logtraces	
TDPR3_CONFIG_FILE	/db2/QAS/dbs/initQAS.utl	
PROLE_SERVICE_NAME	tsmacsdb2	
COPYSERVICES_HARDWARE_TYPE	DS8000	
DB2_REMOTE_DBALIAS	R_QAS	
DB2_RECOVERY_LOG	/db2/QAS/dbs/tdplog/tdpr1f.QAS.NODE0000.log	
DB2_TDPR3_LIB	/usr/tivoli/tsm/tdp_r3/db264/libtdpdb264.a	
PRIMARY_COPYSERVICES_SERVERNAME	9.41.222.208	
COPYSERVICES_SERVERPORT	5988	
COPYSERVICES_USERNAME	superuser	
COPYSERVICES_COMMPROTOCOL	HTTP	
FlashCopy_TYPE	COPY	

---

## Data Protection for FlashCopy target volume file

The Data Protection for FlashCopy target volume file (see Example 12-21), /db2/QAS/dbs/desmoines01/initQAS.fct, should be updated with details of the target LUNs that will be used to do FlashCopy. The target LUNs should match the number and size of the production LUNs.

*Example 12-21 Target volume file*

---

TARGET_VOLUME	75CMRY20100	-	-
TARGET_VOLUME	75CMRY20101	-	-
TARGET_VOLUME	75CMRY20102	-	-

---



In the TARGET\_VOLUME lines, the highlighted number is the serial number of the target volume, and the next two fields are for the serial number and size of the source volume. These two fields do not have to be specified, because they will be automatically populated when the **splitint** program runs for the first time to make the association between the target and source volumes.

## Initializing Data Protection for FlashCopy

We initialize Data Protection for FlashCopy using the db2qas user, as shown in Example 12-22.

### Example 12-22 Initializing Data Protection for FlashCopy

---

```
# su - db2qas
desmoines01:db2qas 1> cd /db2/QAS/dbs
desmoines01:db2qas 2> ./tdphdwb2 -p ./desmoines01/initQAS.fcs -f
configure

      IBM Tivoli Storage Manager for Advanced Copy Services
      Data Protection for FlashCopy Devices for mySAP(R) on DB2
      (tdphdwb2)

      FlashCopy Backup utility for IBM Tivoli Storage Manager
      - Version 5, Release 4, Level 2.0  for AIX (32 Bit) -
      Build: 354 generated at 00:38:32 on Jul 30 2008
      (c) Copyright IBM Corporation, 2000, 2007, All Rights Reserved.

Profile                ./desmoines01/initQAS.fcs
Log file               splitint_?_20080923152826.log
Trace file             splitint_?_20080923152826.trace
Function               configure
Log file               tdphdwb2_?_20080923152826.log
Trace file             tdphdwb2_?_20080923152826.trace

-- Parameters of tdphdwb2 profile --

LOGON_HOST_PROD        desmoines01      db2qas
LOGON_HOST_BACK        nashville01
BACKUP_MAX              30
IDS_CONTROL_FILE       /db2/QAS/dbs/desmoines01/save/idssave
CONFIG_FILE             /db2/QAS/dbs/desmoines01/initQAS.fcp
WORK_DIR               /db2/QAS/dbs/desmoines01/work
TRACE                  YES
LOG_TRACE_DIR          /db2/QAS/dbs/logtraces
TDP3_CONFIG_FILE       /db2/QAS/dbs/initQAS.utl
SUPPORT_ADMIN_ASSISTANT NO
```

```

COPYSERVICES_HARDWARE_TYPE      DS8000
DB2_REMOTE_DBALIAS              R_QAS
DB2_RECOVERY_LOG                /db2/QAS/dbs/tdplog/tdprlf.QAS.NODE0000.log
DB2_TDP3_LIB                    /usr/tivoli/tsm/tdp_r3/db264/libtdpdb264.a
DB2_PARALLELISM                 1
DB2_NUM_BUFFERS                 2
DB2_BUFFER_SIZE                 1024
PRIMARY_COPYSERVICES_SERVERNAME 9.41.222.208
COPYSERVICES_SERVERPORT         5988
COPYSERVICES_USERNAME           superuser
FlashCopy_TYPE                  COPY
VOLUMES_FILE                    /db2/QAS/dbs/desmoines01/initQAS.fct
DB2 instance db2qas is using DB2 UDB Version 9.1.0.3
Checking DB2 Instance Bitwidth...
DB2 instance db2qas is running in 64 bit mode.
IDS2506I The DB2 instance db2qas is running in 64 bit mode. tdphdwb2
is running in compatibility mode.
DP for mySAP Version 5.5.0. found
IDS2105I Start of tdphdwb2 program at: 09/23/08-15:28:26 .
DB2 instance db2qas is a EEE instance.
Default database path: /db2/QAS
TCPIP service name: sapdb2QAS
Enter the TCPIP service port for the socket server [57330]:
Function                          password
IDS2051I: Enter the password for the user 'db2qas'      :
IDS2052I: Enter the password for the user 'db2qas' again:
IDS2051I: Enter the password for the user 'superuser on the DS'      :
IDS2052I: Enter the password for the user 'superuser on the DS' again:
IDS2306I Issuing command 'rah "<>cd /db2path/dbs ; ./tdphdwb2 -f
configure -t EEE -P 57330 -p /db2path/dbs/<>/initQAS.fcs -T 20080923152826"
echo hdwIntRC: $? ' ...
rah: omitting myself, desmoines01
hdwIntRC: 0
IDS2306I Issuing command 'grep idsctlQAS /etc/services | grep -w 57330
echo hdwIntRC: $? ' ...
idsctlQAS                          57330/tcp
hdwIntRC: 0
IDS2306I Issuing command 'chservices -a -v idsctlQAS -p tcp -n 57330
echo hdwIntRC: $? ' ...
idsctlQAS                          57330/tcp
hdwIntRC: 0
IDS2306I Issuing command 'mkitab "sockQAS:2:respawn:su - db2qas -c 'cd
/db2path/dbs ; /db2path/dbs/tdphdwb2 -f initsocket -p
./desmoines01/initQAS.fcs '>/dev/null 2>&1"' ...
IDS2306I Issuing command 'grep idsctlQAS_0 /etc/services | grep -w 57331

```

```

echo hdwIntRC: $? ' ...
idsctlQAS_0          57331/tcp
hdwIntRC: 0
IDS2306I Issuing command 'chservices -a -v idsctlQAS_0 -p tcp -n 57331
echo hdwIntRC: $? ' ...
idsctlQAS_0          57331/tcp
hdwIntRC: 0
IDS2306I Issuing command 'mkitab "sockQAS_0:2:respawn:su - db2qas -c
'cd /db2path/dbs ; /db2path/dbs/tdphdwd2 -f initsocket -p
./desmoines01/initQAS.fcs -s 0 '>/dev/null 2>&1"' ...
IDS2106I Exiting with return code 0.

```

---

### 12.3.7 Other prerequisites for the backup server

This section lists some other prerequisites for the backup server.

- ▶ We have to create a file system called /db2/QAS that is a size of approximately 128 MB, which will be used for creating the DB2 instance home directory.
- ▶ Ensure that the user ID (UID), group ID (GID) used by user db2qas, and the groups dbqasadm and dba in the production system are free in the backup server. These user and groups will be created by the setupDB2BS.sh script in the backup server with the same UID and GID as on the production server.

#### Executing the setupDB2BS script

The setupDB2BS script creates a user and groups, mounts the NFS file system, catalogs the DB2 node and database, creates local directories, and copies various profiles. Execute the setupDB2BS.sh script as root, as shown in Example 12-23.

*Example 12-23 setupDB2BS script*

---

```

[root@nashville01] /usr/tivoli/tsm/acssap/db2
# ./setupDB2BS QAS desmoines01
checking rsh connection to desmoines01...OK
checking 'rsh' command output on desmoines01...OK
checking hostname on desmoines01...OK
hostname on desmoines01 = desmoines01
checking ENV-setting in /etc/environment on desmoines01...OK
checking DB2 Instance on desmoines01...
DB2 UDB V9 found on this machine

```

You have installed a single version of DB2 V9 on the backup system:

Install Path	Level	Fix Pack	Special Install
Number	Install Date		
/opt/IBM/db2/V9.1	9.1.0.0	0	
-----			
Wed Sep 17 16:08:17 2008 CDT			

The DB2 V9 installation path /db2/db2qas/db2\_software is not found on the backup system  
 Select the DB2 V9 installation you want to use for this installation

[1] - /opt/IBM/db2/V9.1

Enter number: [1] 1

DB2 instance db2qas is a DB2 V9 instance  
 checking DB2 Instance Bit-Width on desmoines01...OK  
 DB2 instance db2qas is a 64 bit instance  
 checking DB2 Instance Type on desmoines01...OK  
 DB2 instance db2qas is a EEE instance  
 reading db2nodes.cfg on desmoines01...OK  
 single EEE partition  
 number of Servers : 1  
 list of Servers : desmoines01  
 max # Nodes per Server : 1  
 list of Nodes : 0  
 checking sapdb2QAS TCPIP service port on desmoines01...OK  
 creating TCPIP service port sapdb2QAS 5912/tcp...  
 TCPIP service port ->sapdb2QAS 5912/tcp # SAP DB2  
 Communication Port<- already exists  
 checking DB2\_db2qas TCPIP service port on desmoines01...OK  
 checking DB2\_db2qas\_END TCPIP service port on desmoines01...OK  
 creating TCPIP service port DB2\_db2qas 5914/tcp...  
 TCPIP service port ->DB2\_db2qas 5914/tcp<- already exists  
 creating TCPIP service port DB2\_db2qas\_END 5917/tcp...  
 TCPIP service port ->DB2\_db2qas\_END 5917/tcp<- already exists  
 checking prole setup on desmoines01...OK  
 checking DP for FC socket server configuration for EEE instance:  
 checking idscntlQAS TCPIP service port on desmoines01...OK  
 creating TCPIP service port idscntlQAS 57330/tcp...  
 TCPIP service port ->idscntlQAS 57330/tcp<- already exists  
 checking sockQAS setup on desmoines01...OK  
 checking DP for FC socket server configuration for EEE node: 0  
 checking idscntlQAS\_0 TCPIP service port on desmoines01...OK  
 creating TCPIP service port idscntlQAS\_0 57331/tcp...  
 TCPIP service port ->idscntlQAS\_0 57331/tcp<- already exists  
 checking sockQAS\_0 setup on desmoines01...OK

```
checking NFS Export /db2/QAS/dbs on desmoines01...OK
checking Filesystem /db2/QAS...OK
checking Filesystem /db2/db2qas...OK
creating directories...
  /db2 exists/created
  /db2/db2qas exists/created
  /db2/QAS exists/created
  /db2/QAS/db2qas exists/created
  /db2/QAS/sapdata1 exists/created
  /db2/QAS/sapdata2 exists/created
  /db2/QAS/sapdata3 exists/created
  /db2/QAS/sapdata4 exists/created
  /db2/QAS/log_dir/ exists/created
  /db2/QAS/log_archive exists/created
  /db2/QAS/log_retrieve exists/created
  /db2/QAS/db2dump exists/created
  /db2/QAS/errors exists/created
  /db2/QAS/dbs exists/created
creating group dbqasadm...
  group dbqasadm exists with GID 204
creating user db2qas...
  user db2qas exists with UID 203
changing login shell for user db2qas to /usr/bin/ksh...
checking 'su' command output...OK
creating group dba...
  group dba exists with GID 211
adding user db2qas to group dba...
  user db2qas added successful to group dba
changing owner for directories /db2/QAS...
  chown db2qas.dbqasadm for /db2/QAS successful
creating NFS mount /db2/QAS/dbs from desmoines01...
  NFS mount for /db2/QAS/dbs exists
mounting NFS mount /db2/QAS/dbs...
  mounting NFS mount /db2/QAS/dbs successful
checking DP for FC (tdphdwd2) symbolic link in /db2/QAS/dbs...
checking DP for FC (tdphdwd2) file mode and owner...OK
checking DP for FC (splitint) symbolic link in /db2/QAS/dbs...
checking DP for FC (splitint) file mode and owner...OK
checking license for DP for FC for mySAP... checking license for DP
for mySAP...OK
copying of db2qas user environment from desmoines01 to nashville01...
  /db2/db2qas/.dbenv_nashville01.sh...
  /db2/db2qas/.dbenv_nashville01.csh...
  /db2/db2qas/.profile...
  /db2/db2qas/.cshrc...
```

```

/db2/db2qas/.login...
creating DB2 instance db2qas...
  DB2 instance db2qas exists
checking tsm settings...
  DSM_CONFIG=/db2/QAS/sqlllib/adsm/dsm.opt
  DSM_DIR=/usr/tivoli/tsm/client/ba/bin
  DSM_LOG=/db2/QAS/errors
  DSMI_CONFIG=/usr/tivoli/tsm/client/api/bin64/dsm.opt
  DSMI_DIR=/usr/tivoli/tsm/client/api/bin64
  DSMI_LOG=/var/log/tsm
tsm settings...OK
checking dsm.opt...rm: Remove /db2/QAS/dbs/dsm.opt.copy? n
OK
  checking dsm.sys...OK
checking DB2 authentication on desmoines01...OK
  DB2 Authentication: SERVER_ENCRYPT
  configuring DB2 instance...
    db2set DB2COMM=TCPIP...
    db2 update dbm cfg using SVCENAME sapdb2QAS...
DB20000I The UPDATE DBM CONFIGURATION command completed successfully.
    db2 update dbm cfg using SYSADM_GROUP dbqasadm...
DB20000I The UPDATE DBM CONFIGURATION command completed successfully.
    db2 update dbm cfg using DFTDBPATH /db2/QAS...
DB20000I The UPDATE DBM CONFIGURATION command completed successfully.
    db2 update dbm cfg using DIAGPATH /db2/QAS/db2dump...
DB20000I The UPDATE DBM CONFIGURATION command completed successfully.
    db2 list node directory...

```

#### Node Directory

Number of entries in the directory = 1

#### Node 1 entry:

```

Node name           = REMQAS
Comment             =
Directory entry type = LOCAL
Protocol            = TCPIP
Hostname            = desmoines01
Service name        = sapdb2QAS

```

```

Node name           = REMQAS
  tcpip node REMQAS already cataloged
  db2 list database directory...

```

## System Database Directory

Number of entries in the directory = 1

Database 1 entry:

```
Database alias           = R_QAS
Database name           = QAS
Node name               = REMQAS
Database release level  = b.00
Comment                 =
Directory entry type    = Remote
Authentication          = SERVER_ENCRYPT
Catalog database partition number = -1
Alternate server hostname =
Alternate server port number =

Database alias           = R_QAS
  remote database QAS on REMQAS already cataloged as R_QAS
  db2start...
09/17/2008 16:14:19    0  0  SQL1026N The database manager is
already active.
SQL1026N The database manager is already active.
```

Installation completed successfully

---

Please do the following steps now on BS as user root:

- start setup.sh script for DP for FC for mySAP

```
cd /usr/tivoli/tsm/tdpessr3/db2 (TDP for ESS for mySAP 32bit <= 5.3.0.x)
cd /usr/tivoli/tsm/tdpessr3/db264 (TDP for ESS for mySAP 64bit <= 5.3.0.x)
cd /usr/tivoli/tsm/tdpessr3/db2 (DP for FC for mySAP = 5.3.1.x)
cd /usr/tivoli/tsm/acssap/db2 (DP for FC for mySAP >= 5.4.0.0)
./setup.sh
```
  - start setup.sh script for DP for mySAP < 3.3

```
cd /usr/tivoli/tsm/tdp_r3/ (for TDP for R/3 < 3.2.0.10)
cd /usr/tivoli/tsm/tdp_r3/db2 (for DP for mySAP 32bit >= 3.2.0.10)
cd /usr/tivoli/tsm/tdp_r3/db264 (for DP for mySAP 64bit >= 3.2.0.10)
./setup.sh
```
  - start installer (update install) for DP for mySAP >= 3.3
-

## Executing setup.sh script

Now we have to execute the setup.sh script as root, as shown in Example 12-24.

*Example 12-24 setup.sh script*

---

```
# ./setup.sh
Please enter the SAPSID for the Production SAP System: [C21] QAS
Please enter the DBSID for the Production SAP System: [QAS] QAS
DB2 UDB V9 found on this machine
checking DB2 Instance...OK
DB2 instance db2qas is a DB2 V9 instance
checking DB2 Instance Bit-Width...OK
DB2 instance db2qas is a 64 bit instance
checking DB2 Instance Type...OK
DB2 instance db2qas is a multiple partitions instance

Please enter the path for the configuration files: [/db2/QAS/dbs]
Please enter the path for the executables: [/db2/QAS/dbs]
reading db2nodes.cfg...OK
  single partition
  number of Servers      : 1
  list of Servers       : nashville01
  max # Nodes per Server : 1

Is nashville01 your [P]roduction or [B]ackup server ? [P/B] B
Free space in filesystem = 10150796 KB
Dirname = /db2/QAS/dbs
Space available = 10150796 KB, Required = 10000 KB
Free space in filesystem = 10150796 KB
Dirname = /db2/QAS/dbs
Space available = 10150796 KB, Required = 10000 KB
Free space in filesystem = 1312276 KB
Dirname = /usr/tivoli/tsm/acssap/db2
Space available = 1312276 KB, Required = 100000 KB

group dba exists with GID 211...
user db2qas exists in group dba...
checking TSM ACS mySAP socket server...
creating acsprole TCPIP service port tsmacbdb2 57326/tcp...
waiting for TSM ACS mySAP acsprole to start.....OK
Setup successful.
```

---



**Note:** We have to update the vendor environment file details in the DB2 registry of the backup server using the command **db2set DB2\_VENDOR\_INI=/db2/QAS/dbs/vendor.env** after we run the setup.sh script.

## FlashCopy backup from the backup server

At this stage, the FlashCopy backup can be tested from the backup server, as shown in Example 12-25 using the db2qas user ID.

*Example 12-25 FlashCopy backup*

---

```
# su - db2qas
nashville01:db2qas 1> cd /db2/QAS/dbs
nashville01:db2qas 2> ./tdphdwb2 -p ./desmoines01/initQAS.fcs -f
FlashCopy

IBM Tivoli Storage Manager for Advanced Copy Services
    Data Protection for FlashCopy Devices for mySAP(R) on DB2
    (tdphdwb2)

    FlashCopy Backup utility for IBM Tivoli Storage Manager
    - Version 5, Release 4, Level 2.0 for AIX (32 Bit) -
    Build: 354 generated at 00:38:32 on Jul 30 2008
    (c) Copyright IBM Corporation, 2000, 2007, All Rights Reserved.

IDS1411I The intended FlashCopy type has a value of 'COPY'.
Profile /db2/QAS/dbs/desmoines01/initQAS.fcs
Log file splitint_?_20080919192714.log
Trace file splitint_?_20080919192714.trace
Function FlashCopy
Log file tdphdwb2_?_20080919192714.log
Trace file tdphdwb2_?_20080919192714.trace
-- Parameters of tdphdwb2 profile --
LOGON_HOST_PROD desmoines01 db2qas
LOGON_HOST_BACK nashville01
BACKUP_MAX 30
IDS_CONTROL_FILE /db2/QAS/dbs/desmoines01/save/idssave
CONFIG_FILE /db2/QAS/dbs/desmoines01/initQAS.fcp
WORK_DIR /db2/QAS/dbs/desmoines01/work
TRACE YES
LOG_TRACE_DIR /db2/QAS/dbs/desmoines01/logtraces
TDPR3_CONFIG_FILE /db2/QAS/dbs/initQAS.utl
SUPPORT_ADMIN_ASSISTANT NO
COPYSERVICES_HARDWARE_TYPE DS8000
DB2_REMOTE_DBALIAS R_QAS
```

```

DB2_RECOVERY_LOG /db2/QAS/dbs/tdplog/tdprlf.QAS.NODE0000.log
DB2_TDP3_LIB /usr/tivoli/tsm/tdp_r3/db264/libtdpdb264.a
DB2_PARALLELISM 1
DB2_NUM_BUFFERS 2
DB2_BUFFER_SIZE 1024
PRIMARY_COPYSERVICES_SERVERNAME 9.41.222.208
COPYSERVICES_SERVERPORT 5988
COPYSERVICES_USERNAME superuser
FlashCopy_TYPE COPY
VOLUMES_FILE /db2/QAS/dbs/desmoines01/initQAS.fct
DB2 instance db2qas is using DB2 UDB Version 9.1.0.3
Checking DB2 Instance Bitwidth...
DB2 instance db2qas is running in 64 bit mode.
IDS2506I The DB2 instance db2qas is running in 64 bit mode. tdphdwb2
is running
in compatibility mode.
Data Protection for mySAP Version 5.5.0. found
IDS2005I Start of tdphdwb2 program at: 09/19/08-19:27:14 .
DB2 instance db2qas is a EEE instance.
Default database path: /db2/QAS
TCP/IP service name: sapdb2QAS
Checking for the node directory entry REMQAS ...
DB2 instance db2qas is a EEE instance.
Default database path: /db2/QAS
TCP/IP service name: sapdb2QAS
Checking system database directory
IDS0099I message_id = REQ_DB_READ_DB2NODES_CFG
IDS0099I status = MSG_OK
IDS0099I message_id = ANS_DB_READ_DB2NODES_CFG
IDS0099I status = MSG_OK
connect to Node 0
set client connection to Node 0
Checking for the node directory entry REMQAS_0 ...
Checking system database directory
Connecting to the database R_QAS_0 node 0 with user db2qas using *****
...
TBS name=SYSCATSPACE | ID=0 | Type=DMS | State=0 - Normal
TBS name=SYSTOOLSPACE | ID=1 | Type=DMS | State=0 - Normal
TBS name=SYSTOOLSTMPSPACE | ID=2 | Type=SMS user temp | State=0 -
Normal
TBS name=PSAPTEMP | ID=3 | Type=SMS system temp | State=0 - Normal
TBS name=QAS#STABD | ID=4 | Type=DMS | State=0 - Normal
TBS name=QAS#STABI | ID=5 | Type=DMS | State=0 - Normal
TBS name=QAS#BTABD | ID=6 | Type=DMS | State=0 - Normal
TBS name=QAS#BTABI | ID=7 | Type=DMS | State=0 - Normal

```

TBS name=QAS#CLUD | ID=8 | Type=DMS | State=0 - Normal  
TBS name=QAS#CLUI | ID=9 | Type=DMS | State=0 - Normal  
TBS name=QAS#POOLD | ID=10 | Type=DMS | State=0 - Normal  
TBS name=QAS#POOLI | ID=11 | Type=DMS | State=0 - Normal  
TBS name=QAS#DDICD | ID=12 | Type=DMS | State=0 - Normal  
TBS name=QAS#DDICI | ID=13 | Type=DMS | State=0 - Normal  
TBS name=QAS#DOCUD | ID=14 | Type=DMS | State=0 - Normal  
TBS name=QAS#DOCUI | ID=15 | Type=DMS | State=0 - Normal  
TBS name=QAS#EL620D | ID=16 | Type=DMS | State=0 - Normal  
TBS name=QAS#EL620I | ID=17 | Type=DMS | State=0 - Normal  
TBS name=QAS#LOADD | ID=18 | Type=DMS | State=0 - Normal  
TBS name=QAS#LOADI | ID=19 | Type=DMS | State=0 - Normal  
TBS name=QAS#PROTD | ID=20 | Type=DMS | State=0 - Normal  
TBS name=QAS#PROTI | ID=21 | Type=DMS | State=0 - Normal  
TBS name=QAS#ES620D | ID=22 | Type=DMS | State=0 - Normal  
TBS name=QAS#ES620I | ID=23 | Type=DMS | State=0 - Normal  
TBS name=QAS#SOURCED | ID=24 | Type=DMS | State=0 - Normal  
TBS name=QAS#SOURCEI | ID=25 | Type=DMS | State=0 - Normal  
TBS name=QAS#USERID | ID=26 | Type=DMS | State=0 - Normal  
TBS name=QAS#USERII | ID=27 | Type=DMS | State=0 - Normal  
TBS container name=/db2/QAS/sapdata1/NODE0000/SYSCATSPACE.container000  
TBS container name=/db2/QAS/sapdata1/NODE0000/SYSTOOLSPACE.container000  
TBS container  
name=/db2/QAS/saptemp1/NODE0000/temp4/SYSTOOLSTMPSPACE.000  
TBS container name=/db2/QAS/saptemp1/NODE0000/temp4/PSAPTEMP.000  
TBS container name=/db2/QAS/sapdata1/NODE0000/QAS#STABD.container000  
TBS container name=/db2/QAS/sapdata2/NODE0000/QAS#STABI.container000  
TBS container name=/db2/QAS/sapdata1/NODE0000/QAS#BTABD.container000  
TBS container name=/db2/QAS/sapdata2/NODE0000/QAS#BTABI.container000  
TBS container name=/db2/QAS/sapdata3/NODE0000/QAS#CLUD.container000  
TBS container name=/db2/QAS/sapdata2/NODE0000/QAS#CLUI.container000  
TBS container name=/db2/QAS/sapdata5/NODE0000/QAS#POOLD.container000  
TBS container name=/db2/QAS/sapdata1/NODE0000/QAS#POOLI.container000  
TBS container name=/db2/QAS/sapdata5/NODE0000/QAS#DDICD.container000  
TBS container name=/db2/QAS/sapdata2/NODE0000/QAS#DDICI.container000  
TBS container name=/db2/QAS/sapdata1/NODE0000/QAS#DOCUD.container000  
TBS container name=/db2/QAS/sapdata2/NODE0000/QAS#DOCUI.container000  
TBS container name=/db2/QAS/sapdata6/NODE0000/QAS#EL620D.container000  
TBS container name=/db2/QAS/sapdata2/NODE0000/QAS#EL620I.container000  
TBS container name=/db2/QAS/sapdata3/NODE0000/QAS#LOADD.container000  
TBS container name=/db2/QAS/sapdata2/NODE0000/QAS#LOADI.container000  
TBS container name=/db2/QAS/sapdata3/NODE0000/QAS#PROTD.container000  
TBS container name=/db2/QAS/sapdata2/NODE0000/QAS#PROTI.container000  
TBS container name=/db2/QAS/sapdata3/NODE0000/QAS#ES620D.container000  
TBS container name=/db2/QAS/sapdata1/NODE0000/QAS#ES620I.container000

TBS container name=/db2/QAS/sapdata2/NODE0000/QAS#SOURCED.container000  
TBS container name=/db2/QAS/sapdata3/NODE0000/QAS#SOURCEI.container000  
TBS container name=/db2/QAS/sapdata1/NODE0000/QAS#USER1D.container000  
TBS container name=/db2/QAS/sapdata2/NODE0000/QAS#USER1I.container000  
DB logretain status: RECOVERY  
DB userexit status : ON  
Verifying alias R\_QAS\_0 logpath: /db2/QAS/log\_dir/NODE0000/  
Database Path: /db2/QAS/db2qas/NODE0000/SQL00001/  
IDS0099I message\_id = REQ\_SET\_BACKUPID  
IDS0099I status = MSG\_OK  
IDS0099I message\_id = ANS\_SET\_BACKUPID  
IDS0099I status = MSG\_OK  
IDS1035I The IDS control file exists and a new backup cycle entry has  
been created.  
IDS1101I New assigned Backup Sequence Number 00008  
IDS1025I Time stamp: 09/19/08-19:27:23.  
IDS1026I Start of **splitint** on the production system ...  
IBM Tivoli Storage Manager for Advanced Copy Services  
Data Protection for FlashCopy Devices for mySAP(R) on DB2  
(**tdphdwb2**)

FlashCopy Backup utility for IBM Tivoli Storage Manager  
- Version 5, Release 4, Level 2.0 for AIX (32 Bit) -  
Build: 354 generated at 00:38:32 on Jul 30 2008  
(c) Copyright IBM Corporation, 2000, 2007, All Rights Reserved.

IDS1411I The intended FlashCopy type has a value of 'COPY'.  
Profile /db2/QAS/dbs/desmoines01/initQAS.fcs  
Log file **splitint**\_?\_20080919192714.log  
Trace file **splitint**\_?\_20080919192714.trace  
Function FlashCopy  
Log file **tdphdwb2**\_?\_20080919192714.log  
Trace file **tdphdwb2**\_?\_20080919192714.trace  
-- Parameters of **tdphdwb2** profile --  
LOGON\_HOST\_PROD desmoines01 db2qas  
LOGON\_HOST\_BACK nashville01  
BACKUP\_MAX 30  
IDS\_CONTROL\_FILE /db2/QAS/dbs/desmoines01/save/idssave  
CONFIG\_FILE /db2/QAS/dbs/desmoines01/initQAS.fcp  
WORK\_DIR /db2/QAS/dbs/desmoines01/work  
TRACE YES  
LOG\_TRACE\_DIR /db2/QAS/dbs/desmoines01/logtraces  
TDPR3\_CONFIG\_FILE /db2/QAS/dbs/initQAS.utl  
SUPPORT\_ADMIN\_ASSISTANT NO  
COPYSERVICES\_HARDWARE\_TYPE DS8000

```

DB2_REMOTE_DBALIAS R_QAS
DB2_RECOVERY_LOG /db2/QAS/dbs/tdplog/tdpr1f.QAS.NODE0000.log
DB2_TDPR3_LIB /usr/tivoli/tsm/tdp_r3/db264/libtdpdb264.a
DB2_PARALLELISM 1
DB2_NUM_BUFFERS 2
DB2_BUFFER_SIZE 1024
PRIMARY_COPYSERVICES_SERVERNAME 9.41.222.208
COPYSERVICES_SERVERPORT 5988
COPYSERVICES_USERNAME superuser
FlashCopy_TYPE COPY
VOLUMES_FILE /db2/QAS/dbs/desmoines01/initQAS.fct
DB2 instance db2qas is using DB2 UDB Version 9.1.0.3
Checking DB2 Instance Bitwidth...
DB2 instance db2qas is running in 64 bit mode.
IDS2506I The DB2 instance db2qas is running in 64 bit mode. tdphdwb2
is running
in compatibility mode.
Data Protection for mySAP Version 5.5.0. found
IDS2005I Start of tdphdwb2 program at: 09/19/08-19:27:12 .
IDS2121I Getting the source volumes ...
Function getresources_prod
Subfunction performsplit
Backup list /db2/QAS/dbs/desmoines01/work/tdpessdb2_1st
EEP0156I Finding the serial numbers ...
IDS1404I The target set with ID '1' is selected for this run.
Matching pair tgt: <75CMRY20100> src: <75CMRY20300> size:
<10737418240_Bytes>
Matching pair tgt: <75CMRY20101> src: <75CMRY20301> size:
<10737418240_Bytes>
Matching pair tgt: <75CMRY20102> src: <75CMRY20302> size:
<10737418240_Bytes>
DB2 instance db2qas is a EEE instance.
Default database path: /db2/QAS
TCP/IP service name: sapdb2QAS
Checking system database directory
Checking local database directory /db2/QAS
IDS1602I Waiting for SyncPoint 1 on all EEE nodes...
Get first active logfile for database QAS NODE0000 ...
set client connection to Node 0
First active logfile for DB QAS is: S0000021.LOG
IDS1602I Waiting for SyncPoint 2 on all EEE nodes...
IDS1602I Waiting for SyncPoint 3 on all EEE nodes...
IDS2560I Suspend database QAS NODE0000 write activities...
IDS0099I message_id = REQ_DB_SUSPEND
IDS0099I status = MSG_OK

```

```

IDS0099I message_id = ANS_DB_SUSPEND
IDS0099I status = MSG_OK
IDS1602I Waiting for SyncPoint 4 on all EEE nodes...
.. IDS2122I FlashCopying the sources to the target volumes ...
Function FlashCopy_prod
Subfunction performsplit
Backup list /db2/QAS/dbs/desmoines01/work/tdpessdb2_1st
EEP0272I Flushing the buffers to disk...
IDS1030I FlashCopy started ...
EEP1625I Number of volumes to be processed by FlashCopy: 3
EEP0354I Performing COPY FlashCopy of source volume 75CMRY20300 to
target volume
75CMRY20100
EEP0354I Performing COPY FlashCopy of source volume 75CMRY20301 to
target volume
75CMRY20101
EEP0354I Performing COPY FlashCopy of source volume 75CMRY20302 to
target volume
75CMRY20102
IDS1031I FlashCopy successful.
IDS1602I Waiting for SyncPoint 5 on all EEE nodes...
...
IDS2562I Resume database QAS NODE0000 write activities...
IDS0099I message_id = REQ_DB_RESUME
IDS0099I status = MSG_OK
IDS0099I message_id = ANS_DB_RESUME
IDS0099I status = MSG_OK
IDS1602I Waiting for SyncPoint 6 on all EEE nodes...
...
IDS1602I Waiting for SyncPoint 7 on all EEE nodes...
...
BID 20060719192714
UTL /db2/QAS/dbs/initQAS.utl
INF -
EBT -
EBB FULL_ONLINE_DISK_ONLY
EBC :0000:/db2/QAS/log_dir/NODE0000/
EBR :0000:S0000021.LOG
IDS2033I Information from Data Protection for mySAP has been found with
BACKUPID
20060719192714.
IDS1602I Waiting for SyncPoint 8 on all EEE nodes...
...
IDS2124I Exiting with return code 0.
#INFO remote shell terminated successfully

```

```

IDS1027I splitint ended successfully on the production system.
IDS1025I Time stamp: 09/19/08-19:28:56.
IDS1540I Start of fcagent on the backup system ...
IDS2123I Enabling the volumes and filesystems ...
Function setresources
Backup list /db2/QAS/dbs/desmoines01/save/tdpessdb2_1st
IDS1076I Trying to set the semaphore for the critical part of
importing/exporting
...
IDS1046I Start of listing of importing volume groups/mounting file
systems ...
EEP0126I Trying to find new devices to match the source device. This
process will
take some time.....
EEP0148I Importing volume groups now...
EEP0149I Newly imported volume group: QAS_0tdp1
EEP0124I Mounting filesystem : /db2/QAS/db2qas.
EEP0124I Mounting filesystem : /db2/QAS/sapdata1.
EEP0124I Mounting filesystem : /db2/QAS/sapdata2.
EEP0124I Mounting filesystem : /db2/QAS/sapdata3.
EEP0124I Mounting filesystem : /db2/QAS/sapdata5.
EEP0124I Mounting filesystem : /db2/QAS/sapdata6.
EEP0124I Mounting filesystem : /db2/QAS/saptemp1.
IDS1077I Semaphore released.
IDS1047I End of listing.
IDS1025I Time stamp: 09/19/08-19:31:44.
IDS1602I Waiting for SyncPoint 1 on all EEE nodes...
...
waiting for socket server to stop...
IDS2124I Exiting with return code 0.

```

---

The return code 0 indicates that the backup was successful.

### 12.3.8 FlashBack restore

FlashBack restore uses the FlashCopy reverse copy to restore a database directly from the backup disk volumes (target volumes) to the original location (source volumes) of the production system. FlashBack restore can restore FlashCopy images created by the **tdphdwb2 -f backup** and **tdphdwb2 -f FlashCopy** commands. FlashBack restore offers the following benefits. You can:

- ▶ Do a quick restore in the event of a database failure.
- ▶ Restore the operating system storage structure (file system, volume group, and tablespaces).

- ▶ Make multiple FlashCopy backups at different times, depending on how much disk you want to use for FlashCopies. This means you can restore the database to different points in time by selecting which target to FlashBack.

There are a number of situations where FlashBack restore must not be used. It is very important to read carefully the sections “When Not to Use FlashBack Restore” and “FlashBack Restore Limitations” in the manual, *Data Protection for FlashCopy Devices for mySAP Installation and User’s Guide for DB2 UDB*, SC33-8208. Special attention is required when making any change to the production server’s hardware configuration, to make sure proper maintenance procedures are observed. We recommend thorough testing of FlashBack restore procedures. Also, the integrity of the FlashCopy target volumes must be maintained; there must be no updates to them after the FlashCopy is complete.

FlashBack restore is not possible in these circumstances, among others:

- ▶ If the Data Protection for FlashCopy target volume file (.fct) for the FlashBack Restore is different from the target volume files used for the FlashCopy backup.
- ▶ If you are unsure of what backup images you have on the target volumes that you plan to restore using FlashBack Restore.
- ▶ If the source volume configuration on the production system differs from the source volume configuration during the FlashCopy backup, and you want to preserve the new source volume configuration (for example, if a volume has been added or deleted on the production system since the FlashCopy backup).
- ▶ If the backup of the database was performed using Data Protection for FlashCopy with the FlashCopy\_TYPE parameter specified as NOCOPY.
- ▶ If the FlashCopy agent process is not physically completed.
- ▶ If there are logical volumes or file systems that belong to other applications in the database volume group, this can cause integrity problems. We recommend having only file systems and logical volumes that are part of the SAP database in the database volume group.
- ▶ FlashBack Restore cannot restore a database that was backed up with a version of Data Protection for ESS earlier than Version 5.3.
- ▶ The database copy on the target set to be restored must not have been brought online on the backup system at any time after the Data Protection for FlashCopy backup, because in this case, the integrity of the FlashCopy target volumes cannot be guaranteed. You can maintain the database copy as a standby database using **db2inidb <dbname> as standby** (which is how the Tivoli Storage Manager backup, if made, is done).



- ▶ If you run the **withdraw** command for the target volumes, the integrity of the FlashCopy target volumes cannot be guaranteed; FlashBack restore is not possible.
- ▶ A FlashCopy backup from ESS volumes cannot be restored directly to DS volumes.

## 12.4 Implement Advanced Copy Services for SAP (Oracle)

Figure 12-2 shows our lab environment that was used for implementing Advanced Copy Services for SAP (Oracle).

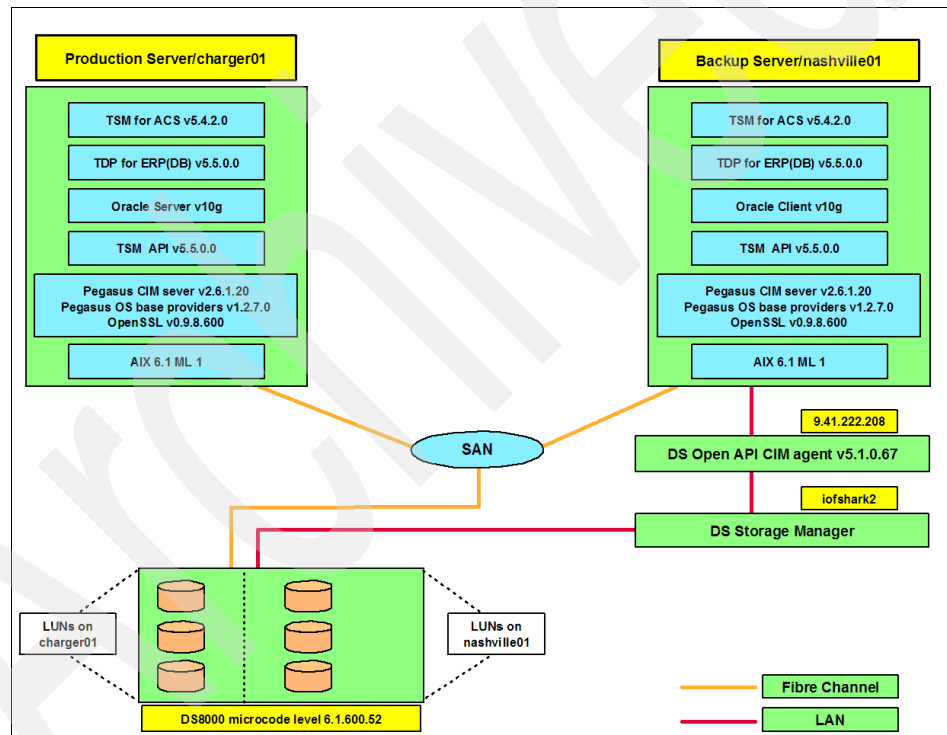

Figure 12-2 Advanced Copy Services for SAP (Oracle) lab environment

The installation and configuration tasks required for FlashCopy to work with SAP using Oracle database are:

- ▶ 12.4.1, “Data Protection for SAP (Oracle) installation and configuration” on page 358
- ▶ 12.4.2, “Password handling methods” on page 359
- ▶ 12.4.3, “CIM installation and configuration” on page 360
- ▶ 12.4.4, “Data Protection for FlashCopy installation” on page 360
- ▶ 12.4.5, “Data Protection for FlashCopy configuration” on page 362

## 12.4.1 Data Protection for SAP (Oracle) installation and configuration

Before starting the installation of Data Protection for SAP on the production system, you should collect the following information, which will be required during the installation process:

- ▶ Oracle database SID: In our case, the SID name is ORC.
- ▶ Directory where the SAP BR\*Tools are located: Usually, it is located in `/usr/sap/<SID>/SYS/exe/run`.
- ▶ Directory where the SAP configuration file (`initSID.sap`) is located: Normally, it will be in `/oracle/ORC/102_64/dbs`.
- ▶ Tivoli Storage Manager server: The name must already exist in the API's `dsm.sys` file. This is the tag name used against the `SERVERNAME` option in the `dsm.sys` file. We use the name `lincoln02` in `dsm.sys`.
- ▶ Tivoli Storage Manager node name: Our Tivoli Storage Manager node name for keeping Data Protection for SAP (Oracle) backups is `charger01_tdp`.
- ▶ Management class for database backups: Our management class for keeping ORC instance database objects is `dbbackups`.
- ▶ Management classes for log file backups: Our management class for keeping ORC instance log objects is `logs`.
- ▶ Network address of Administration Assistant Server (Optional): We used a Windows machine with the IP address `9.41.222.171` for Administration Assistant Server.
- ▶ Port for Administration Assistant Server (Optional): We used the default port.

### Installation on the production server

We used ASCII mode for our installation, as discussed in 10.3, “Tivoli Storage Manager for ERP - Oracle installation” on page 275. The code is installed in the `/usr/tivoli/tsm/tdp_r3/ora64` directory, if it is 64-bit code.

## Installation on the backup server

Follow the same procedure and use the same values as on the production server except for the following parameters:

- ▶ Directory where the SAP BR\*Tools are located:  
Specify a dummy directory, because we will be using `/sapmnt/<SID>` from the production server using NFS. Actually, `/usr/sap/<SID>/SYS/exe/run` is just a link pointing to `/sapmnt/<SID>/exe`. We use `/tmp/r3install` as a dummy directory.
- ▶ Directory where the SAP configuration file (`initSID.sap`) is located:  
Specify a dummy directory, because we will be using the same configuration files from `/oracle/<SID>/102_64/dbs` of the production server using NFS. We use `/tmp/r3install` as a dummy directory.

### 12.4.2 Password handling methods

You can choose to have the node password handled by Data Protection for SAP (Oracle) or by the Tivoli Storage Manager client API. Based on the method you choose, a slightly different configuration is required. If you choose to manage with Data Protection for SAP utility files, configuration is only required on the production system only. However, if you decide to manage through the client API, the system options file must be updated on both the production and backup server.

#### Password handled by Data Protection for SAP (Oracle)

In this method, the password is stored in the Data Protection for SAP (Oracle) binary configuration file, `/oracle/<SID>/102_64/dbs/init<SID>.bki`, which takes the configuration information from the utility file `init<SID>.ut1`, as shown in Example 12-26. These files are shared between the production and backup server, so only the copy on the production server has to be updated. If the password expires in Tivoli Storage Manager, you must update the new password in Tivoli Storage Manager and configure the same in Data Protection for SAP (Oracle).

*Example 12-26 Data Protection for SAP (Oracle) utility file `initQRC.ut1`*

---

```
PASSWORDREQUIRED YES
ADSMNODE charger01_tdp
```

---

You also have to update the password using `backint` on the production server.

## Password handled by Tivoli Storage Manager API

In this method, the password is stored by the Tivoli Storage Manager API. If the password expires in the Tivoli Storage Manager server, the client API updates the password and stores it. You do not have to change anything in Data Protection for SAP (Oracle). The `dsm.sys` file resides in `/usr/tivoli/tsm/client/api/bin64/`.

*Example 12-27 Tivoli Storage Manager client API options file `dsm.sys`*

---

```
passwordaccess generate
nodename charger01_tdp
```

---

Entries required in the Data Protection for SAP (Oracle) utility file (`/oracle/<SID>/dbs/init<SID>.utl`) are shown in Example 12-28.

*Example 12-28 Data Protection for SAP (Oracle) utility file `initORC.utl`*

---

```
PASSWORDREQUIRED NO
# AD SMNODE charger01_tdp
```

---

## 12.4.3 CIM installation and configuration

Refer to 12.3.4, “CIM installation and configuration” on page 333 for more information about this topic. The procedure for installing and configuring CIM is the same.

## 12.4.4 Data Protection for FlashCopy installation

You should check the following items before starting the installation:

- ▶ The `rshd` and `rexecd` daemons must be enabled on the production server, and you should refresh the `inetd` daemon if any changes were made to the `inetd.conf` file.
- ▶ Ensure that the `.rhosts` file is created in the home directory of the Oracle user ID (`oraorc` in our configuration) to enable the `rsh` command to work from the backup server to the production server.
- ▶ NFS export the configuration directories `/oracle/ORC/102_64`, `/oracle/ORC/sapreorg`, `/oracle/ORC/sapbackup`, and `/sapmnt/ORC`, as they are common directories for Data Protection for SAP (Oracle), Data Protection for FlashCopy configuration files, work directory, and log files, and we want to keep the information consistent across both the production and backup servers.

The installation must be done as the root user. We used ASCII mode to do the installation, as shown in Example 12-29

*Example 12-29 ACS for SAP for Oracle installation*

---

```
# ./5.4.2.0-TIV-TSMACSSAPDORAFTP-AIX.bin -console
```

```
      Initializing InstallShield Wizard.....  
      Launching InstallShield Wizard.....
```

```
-----  
Welcome to ...  
IBM Tivoli Storage Manager for Advanced Copy Services Data Protection  
for FlashCopy Devices for mySAP  
This will install Data Protection for FlashCopy Devices for mySAP on  
your computer. Version 5.4.2.0. Please visit our webpage:
```

```
      http://www.ibm.com/software/tivoli
```

```
Press 1 for Next, 3 to Cancel or 5 to Redisplay [1] 1
```

```
-----  
IBM Licence Acceptance Panel
```

```
      . . .
```

```
Press Enter to continue viewing the license agreement, or, Enter "1" to  
accept the agreement, "2" to decline it or "99" to go back to the  
previous screen, "3" Print, "4" Read non-IBM terms.
```

```
1
```

```
Press 1 for Next, 2 for Previous, 3 to Cancel or 5 to Redisplay [1] 1
```

```
-----  
Data Protection for FlashCopy Devices for mySAP will be installed in  
the following location:
```

```
      /usr/tivoli/tsm/acssap/oracle
```

```
with the following features:
```

```
      Oracle_AIX
```

```
for a total size:
```

```
      70 MB
```

```
Press 1 for Next, 2 for Previous, 3 to Cancel or 5 to Redisplay [1] 1
```

Installing Data Protection for FlashCopy Devices for mySAP. Please wait...

```
|-----|-----|-----|-----|
0%      25%    50%    75%    100%
||||||||||||||||||||||||||||||||||||||||||||||||||||||||
```

Creating uninstaller...

Finalizing the Vital Product Data Registry. Please wait...

-----  
Please read the information below.

ATTENTION!

You have to execute the script `./setup.sh` once for each user who will run Data Protection for FlashCopy Devices for mySAP. You will find the script `setup.sh` in the installation directory `/usr/tivoli/tsm/acssap/oracle`.

Press 1 for Next, 2 for Previous, 3 to Cancel or 5 to Redisplay [1] 1

-----  
The InstallShield Wizard has successfully installed Data Protection for FlashCopy Devices for mySAP. Choose Finish to exit the wizard.

Press 3 to Finish or 5 to Redisplay [3] 3  
-----

## 12.4.5 Data Protection for FlashCopy configuration

This section describes the initialization and setup required on the production server. The setup includes the following tasks:

- ▶ “Executing the `setup.sh` script on the production server” on page 363
- ▶ “Customizing Data Protection for FlashCopy profile” on page 364
- ▶ “Data Protection for FlashCopy target volume file” on page 364
- ▶ “Customizing Data Protection for SAP to enable FlashCopy” on page 365
- ▶ “Customizing the BR\*Tools profile to enable FlashCopy” on page 365
- ▶ “Initializing Data Protection for FlashCopy” on page 365
- ▶ “Preparing for Oracle SQL\*NET” on page 366
- ▶ “Creating directories and links for SAP executables” on page 367
- ▶ “Setting up an SAP environment for user `ora<SID>`” on page 367
- ▶ “Oracle client” on page 368

- ▶ “Executing the setup.sh script on the backup server” on page 368
- ▶ “FlashCopy backup from the backup server” on page 369

### Executing the setup.sh script on the production server

After the Data Protection for FlashCopy code installation, execute the setup.sh script, which copies the configuration files to the correct location and name, and creates links to the Data Protection for FlashCopy executables. Run the script as the root user, as shown in Example 12-30.

#### *Example 12-30 setup.sh script execution*

---

```
[root@charger01] /usr/tivoli/tsm/acssap/oracle
# ./setup.sh
Please enter the SAPSID for the Production SAP System: [C21] ORC
Please enter the DBSID for the Production SAP System: [ORC] ORC
Oracle user oraorc found
Please enter the path for the executables: [/usr/sap/ORC/SYS/exe/run]
Please enter the path for the configuration files:
[/oracle/ORC/102_64/dbs]
Free space in filesystem = 20034256 KB
Dirname = /usr/sap/ORC/SYS/exe/run
Space available = 20034256 KB, Required = 10000 KB
Free space in filesystem = 290460896 KB
Dirname = /oracle/ORC/102_64/dbs
Space available = 290460896 KB, Required = 10000 KB
Free space in filesystem = 1125036 KB
Dirname = /usr/tivoli/tsm/acssap/oracle
Space available = 1125036 KB, Required = 100000 KB

Directory /usr/tivoli/tsm/acssap/oracle/5.4.2.0 will be created
creating acsprole TCP/IP service port tsmacsora 57325/tcp...

waiting for TSM ACS mySAP acsprole to start.....OK
Setup successful.
```

---

## Customizing Data Protection for FlashCopy profile

The Data Protection for FlashCopy profile `/oracle/ORC/102_64/dbs/initORC.fcs` has to be updated, as shown in Example 12-31. Values for `PRIMARY_COPYSERVICES_SERVERNAME`, `COPYSERVICES_SERVERPORT` and `COPYSERVICES_USERNAME` should correspond to the CIM agent for an ESS, DS6000, or DS8000 installation, or from the Master Console, if you are using a SAN Volume Controller. Make sure to use the http port, not the secure https port.

*Example 12-31 Data Protection for FlashCopy profile initORC.fcs*

---

LOGON_HOST_PROD	charger01 oraorc
LOGON_HOST_BACK	nashville01
BACKUP_MAX	30
IDS_CONTROL_FILE	/oracle/ORC/sapbackup/idssave/idssave
CONFIG_FILE	/oracle/ORC/102_64/dbs/initORC.fcp
WORK_DIR	/oracle/ORC/sapbackup/work
TRACE	YES
LOG_TRACE_DIR	/oracle/ORC/sapbackup/logtraces
VOLUMES_FILE	/oracle/ORC/102_64/dbs/initORC.fct
COPYSERVICES_HARDWARE_TYPE	DS8000
PRIMARY_COPYSERVICES_SERVERNAME	9.41.222.208
COPYSERVICES_SERVERPORT	5988
COPYSERVICES_USERNAME	superuser
COPYSERVICES_COMMPROTOCOL	HTTP
FlashCopy_TYPE	INCR

---

## Data Protection for FlashCopy target volume file

The Data Protection for FlashCopy target volume file for the ORC instance, `/oracle/ORC/102_64/dbs/initORC.fct`, should be updated with details of the target LUNs that will be used to do FlashCopy, as shown in Example 12-32. The target LUNs should match the number and size of the production LUNs.

*Example 12-32 Target volume file initORC.fct*

---

TARGET_VOLUME	<b>75CMRY20103</b>	-	-
TARGET_VOLUME	<b>75CMRY20104</b>	-	-
TARGET_VOLUME	<b>75CMRY20105</b>	-	-

---

In the `TARGET_VOLUME` lines, the highlighted number is the serial number of the target volume, the next two fields are for the serial number and size of the source volume. These two fields do not have to be specified, because they will be automatically populated when the `splitint` program runs for the first time to make the association between the target and source volumes.



## Customizing Data Protection for SAP to enable FlashCopy

The Data Protection for SAP utility file

`/oracle/<SID>/102_64/dbs/init<SID>.utl` must be updated by inserting the line shown in Example 12-33 to facilitate interfacing with Data Protection for FlashCopy.

*Example 12-33 Updating Data Protection for SAP (Oracle) utility file `initORC.utl`*

---

```
FCS_FILE /oracle/ORC/102_64/dbs/initORC.fcs
```

---

## Customizing the BR\*Tools profile to enable FlashCopy

The BR\*Tools profile `/oracle/<SID>/102_64/dbs/init<SID>.sap` file should be updated with the lines shown in Example 12-34 to facilitate interfacing with Data Protection for FlashCopy.

*Example 12-34 Updating BR\*Tools profile to enable FlashCopy `initORC.sap`*

---

```
backup_type = online_mirror  
split_options = "-p /oracle/ORC/102_64/dbs/initORC.fcs"  
split_resync = yes  
primary_db = ORC.WORLD
```

---

The parameter `backup_type` specifies the type of FlashCopy that `brbackup` will do as a default. In this case, it is an `online_mirror`. You can override this when you run `brbackup` by specifying the `-t` option on the command line. `split_options` allows options to be passed on to `splitint`, `split_resync` will unmount the file system, export the volume group, and potentially release the target volumes when the backup to Tivoli Storage Manager is complete on the backup server, and `primary_db` points to the Oracle instance string of the database referred to in the `tnsnames.ora` Oracle file.

## Initializing Data Protection for FlashCopy

We initialize Data Protection for FlashCopy using the `oraorc` user, as shown in Example 12-35.

*Example 12-35 Initializing Data Protection for FlashCopy*

---

```
# su - oraorc  
charger01:oraorc 8> cd 102_64/dbs  
charger01:oraorc 10> splitint -f password -p initORC.fcs
```

BR\*Tools Interface `splitint` for IBM Tivoli Storage Manager  
- Version 5, Release 4, Level 2 for AIX (32 Bit) -  
Build: 304 generated at 14:34:45 on Mar 14 2006  
(c) Copyright IBM Corporation, 2007 All Rights Reserved.

```

IDS1411I The intended FlashCopy type has a value of 'INCR'.
Profile ./initORC.fcs
Log file splitint_?_20082709223522.log
Trace file splitint_?_20082709223522.trace
-- Parameters of splitint profile --
LOGON_HOST_PROD charger01 oraorc
LOGON_HOST_BACK nashville01
BACKUP_MAX 30
IDS_CONTROL_FILE          /oracle/ORC/sapbackup/idssave/idssave
CONFIG_FILE               /oracle/ORC/102_64/dbs/initORC.fcp
WORK_DIR                  /oracle/ORC/sapbackup/work
TRACE YES
LOG_TRACE_DIR             /oracle/ORC/sapbackup/logtraces
SUPPORT_ADMIN_ASSISTANT NO
COPYSERVICES_HARDWARE_TYPE DS8000
PRIMARY_COPYSERVICES_SERVERNAME 9.41.222.208
COPYSERVICES_SERVERPORT 5988
COPYSERVICES_USERNAME superuser
FlashCopy_TYPE INCR
VOLUMES_FILE              /oracle/ORC/102_64/dbs/initORC.fct
IDS1015I Start of splitint program at: 09/27/08-22:35:22 .
Function password
IDS1051I: Enter the password for the user 'oraorc' :
IDS1052I: Enter the password for the user 'oraorc' again:
IDS1051I: Enter the password for the user 'superuser on the DS' :
IDS1052I: Enter the password for the user 'superuser on the DS' again:
IDS1023I Exiting with return code 0.

```

---

## Preparing for Oracle SQL\*NET

Create an Oracle password file using the user ID ora<sid>. In our case, the <password> is the password of the Oracle user sys. The Oracle parameter file /oracle/<SID>/102\_64/dbs/init<SID>.ora should to be updated with the entry shown in Example 12-36. After the entry is made, Oracle must be restarted for the parameter to take effect.

*Example 12-36 Updating oracle parameter file - nitORC.ora*

---

```
remote_login_passwordfile = exclusive
```

---

We have to provide SYSOPER authority to the Oracle user system in the production database. This sub-section lists some other prerequisites for the backup server.

We must create a file system called `/oracle/ORC`, approximately 128 MB in size, which will be used for creating the Oracle home directory, and create `/usr/sap/ORC`, approximately 128 MB in size, which will be used for creating the required directories and links to the SAP executables. After the file systems are created, mount them.

**Note:** The following file systems have to be NFS mounted from the production server:

- ▶ `/oracle/<SID>/102_64`
- ▶ `/oracle/<SID>/sapreorg`
- ▶ `/oracle/<SID>/sapbackup`
- ▶ `/sapmnt/<SID>`

User `ora<SID>`, `<SID>adm` and groups `dba` and `sapsys` must be created on the backup server with the same UIDs and GIDs as on the production server.

### Creating directories and links for SAP executables

We access the SAP executables from the production server using NFS mount instead of installing BR\*Tools on the backup server. This requires certain directories and links to be created with the correct permissions, as shown in Example 12-37.

*Example 12-37 Creating directories and links for SAP executables*

---

```
root@nashville01:/ # cd /usr/sap/ORC
root@nashville01:/ # mkdir -p SYS/exe
root@nashville01:/ # chown -R orcadm:sapsys SYS
root@nashville01:/ # cd SYS/exe
root@nashville01:/ # ln -s /sapmnt/ORC/exe dbg
root@nashville01:/ # ln -s dbg run
```

---

### Setting up an SAP environment for user `ora<SID>`

The SAP environment has to be set up for user `ora<SID>` (`oraorc`) by copying the following files from the `/oracle/<SID>` directory of production server and renaming them:

- ▶ `.sapenv_<hostname>.sh`
- ▶ `.sapenv_<hostname>.csh`
- ▶ `.dbenv_<hostname>.sh`
- ▶ `.dbenv_<hostname>.csh`
- ▶ `.profile`
- ▶ `.cshrc`
- ▶ `.login`

In the production server, the files will be named with the production host name, so after copying them to the backup server, rename them with the host name of the backup server.

## Oracle client

The Oracle client is required on the backup server, so it must be installed. However, because we are accessing the `/oracle/<SID>/102_64/dbs` directory from the production server using NFS, we tried two alternative methods to have access to the required executables without actually installing the Oracle client on the backup server.

- ▶ Option 1: Put the Oracle client path from the production server into our LIBPATH environment variable using the `.profile` file of our Oracle user. Add the statement **export LIBPATH=\$LIBPATH:/oracle/ORC/102\_64/lib**.
- ▶ Option 2: Create a structure for the Oracle client directories to match the production server. The commands to do this task are shown in Example 12-38.

### *Example 12-38 Structure required for Oracle client*

---

```
root@nashville01:/ mkdir -p /oracle/client/102_64
root@nashville01:/ chown -R oraORC:dba /oracle/client
root@nashville01:/ ln -s /oracle/ORC/102_64/jdbc
/oracle/client/102_64/jdbc
root@nashville01:/ ln -s /oracle/ORC/102_64/lib
/oracle/client/102_64/lib
```

---

## Executing the setup.sh script on the backup server

Execute the `setup.sh` script as root, as shown in Example 12-39.

### *Example 12-39 Execution of setup.sh script*

---

```
root@nashville01:/ cd /usr/tivoli/tsm/acssap/oracle
root@nashville01:/usr/tivoli/tsm/acssap/oracle ./setup.sh
Please enter the SID for the Production SAP System: [C21] ORC
Oracle user oraorc found
Please enter the path for the executables: [/usr/sap/ORC/SYS/exe/run]
/usr/sap/ORC/SYS/exe/run
Please enter the path for the configuration files:
[/oracle/ORC/102_64/dbs] /oracle/ORC/102_64/dbs
/oracle/ORC/102_64/dbs/initORC.fcs already exists. Old .fcs will be
kept.
/oracle/ORC/102_64/dbs/initORC.fct already exists. Old .fct will be
kept.
/usr/sap/ORC/SYS/exe/run/splitint already exists. Rename ? [Y/N] n
```

```
/usr/sap/ORC/SYS/exe/run/PreRestore.sh already exists. Rename ? [Y/N] n
/usr/sap/ORC/SYS/exe/run/PostRestore.sh already exists. Rename ? [Y/N] n
Setup successful.
```

---

### FlashCopy backup from the backup server

At this stage, the FlashCopy backup can be tested from the backup server, as shown in Example 12-40, using the oraorc user ID.

*Example 12-40 FlashCopy backup*

---

```
oraorc@nashville01:/oracle/ORC>brbackup -c -u system/<password>
```

---

The <password> has to be replaced with the actual password of the Oracle user system. The return code 0 indicates that the backup was successful.

**Note:** Coverage of Oracle recovery techniques is beyond the scope of this book. If you are not sure how to perform the Oracle database and SAP software application recovery, be sure to contact your SAP or Oracle consultant.

## 12.5 FlashCopy cloning of SAP databases

There is an additional offering available to clone an SAP database on the backup system. *FCClone* is a service offering from IBM Tivoli Solution Development that uses the functionality of Data Protection for FlashCopy for cloning an SAP system.

There are many reasons for cloning an SAP database, such as:

- ▶ **Function testing:** To replicate a production environment, so that new releases, functions, or upgrades can be validated in a test environment.
- ▶ **Performance testing:** A cloned database can also be used for stress or performance testing.
- ▶ **Learning:** To set up a current image before each class.
- ▶ **Reporting and batch jobs:** These can be done from a copy of a database to free the production database from the workload and to make a batch job restartable in case of an unexpected termination.

SAP supports different ways for cloning, which are described in the SAP manual *Homogeneous System Copy*, found at the following address:

<http://www.sapdb.org/7.4/htmhelp/21/692225b246b24f9202cb4433b5d691/content.htm>

The following methods can be used:

- ▶ SAP copy tools R3SETUP and R3LOAD.
- ▶ Database-specific copy tools.
  - Oracle: Use **brbackup** and **brrestore** to back up and clone with a new SID.
  - DB2 UDB: Use the SAP DBA tool **brdb6brt** for a redirected restore.
- ▶ Using Data Protection for FlashCopy cloning. This method significantly reduces the time required for cloning without impacting the production database.

## 12.5.1 FCClone process

The general process of cloning using FlashCopy is to make a FlashCopy of the production database onto a target set, then to make the new clone copy onto another target set. You can then access the cloned database on the backup server, or it could also be accessed on another suitably installed SAP software server, providing this server has access to both the FlashCopy and cloned database target sets.

The actual cloning process when using Data Protection for FlashCopy is slightly different, depending on the database.

### FCClone in Oracle

For SAP software installed on Oracle databases, the steps are as follows:

1. The FCClone process is started by the script FCclone.sh.
2. This executes pre-processing scripts.
3. The last FlashCopy clone is unmounted.
4. FCClone calls **brbackup**, which calls Data Protection for FlashCopy. That starts an online or offline FlashCopy backup. When all resources are mounted on the backup server (that is, when **splitint** is complete), Data Protection for FlashCopy stops the **brbackup** processing.
5. A copy of the original database is now accessible on the backup server.
6. FCClone now starts the command **orac1onedb** to perform all the required steps for cloning.

7. The cloned database is now operational and FCClone will execute post-processing scripts.

### **FCClone in DB2**

For SAP software installed on DB2 databases, the steps are:

1. The FCClone process is started by the script FCclone.sh, which executes pre-processing scripts.
2. The last FlashCopy clone is unmounted.
3. FCClone calls **tdphdwb2** to start an online FlashCopy backup.
4. A copy of the original database is now accessible on the backup server.
5. FCClone now starts **db2c1onedb** to perform all the required steps for cloning.
6. The cloned database is now operational and FCClone will execute post-processing scripts.

## **12.5.2 Installation requirements for FCClone**

The requirements for the hardware, the software, and the environment are the same as for DB for FlashCopy. The cloning system and the backup system can be installed on the same or on a different AIX server, but cannot be installed on the production system.

Different target volume sets should be used for FlashCopy backup and FlashCopy cloning.

### **Additional requirements for SAP software installed on DB2**

Here are some additional requirements for SAP software installed on DB2:

- ▶ DB2 UDB ESE has to be installed at the same level on both the production and the backup servers.
- ▶ DB2 UDB ESE databases can be single partitioned as well as multi partitioned.
- ▶ All files and volumes required for backup and cloning must reside on the same disk storage system.
- ▶ Verify settings for users db2<SID> and db2<NEWSID> for both csh and ksh.
- ▶ If the SAP Kernel release is greater than or equal to 6.10, then the environment variable DBS\_ORA\_SCHEMA has to be set for user db2<SID> and <SID>adm to the production system database schema.

- ▶ A remote shell connection for user db2<SID> should already be established between the backup and the production system at the preinstallation steps for Data Protection for FlashCopy.

### **Additional requirements for SAP software installed on Oracle**

Here are some additional requirements for SAP software installed on Oracle:

- ▶ Oracle has to be installed at the same level on both the production and the backup servers.
- ▶ Verify settings for users ora<SID> and ora<NEWSID> for both csh and ksh.
- ▶ If the SAP Kernel release is greater than or equal to 6.10, then the environment variable DBS\_ORA\_SCHEMA has to be set for user ora<SID> and <SID>adm to the production system database schema.
- ▶ User ora<NEWSID> has to use ksh as the login shell.

**Note:** Raw devices or JFS2 file systems with JFS2 inline logs are not supported for both DB2 and Oracle databases. Oracle 8 is no longer supported.



## Appendixes

The provided appendixes are:

- ▶ Appendix A, “DB2 basic operations” on page 375
- ▶ Appendix B, “Oracle basic operations” on page 383

Archived

## DB2 basic operations

This appendix shows some basic DB2 operations commands. If you are an experienced database administrator you should skip to Appendix B, “Oracle basic operations” on page 383. The topics discussed in this appendix are:

- ▶ “Get information about the current DB2 instance” on page 376
- ▶ “Listing the current active databases” on page 376
- ▶ “Connecting to an active database” on page 376
- ▶ “Configuration parameters for the current instance” on page 376
- ▶ “Configuration parameters for the current database” on page 377
- ▶ “Listing tablespaces information” on page 378
- ▶ “Monitoring backup and restore” on page 380
- ▶ “Listing backup history” on page 380

## Get information about the current DB2 instance

To get the current DB2 instance name, you can use the **db2 get instance** command. The result is shown in Example 12-41.

*Example 12-41 Instance name*

---

```
desmoines01:db2qas 20> db2 get instance
```

```
The current database manager instance is: db2qas
```

---

## Listing the current active databases

To list the current active database for the current instance, you can use the **db2 list active databases** command. The result is shown in Example 12-42.

*Example 12-42 Current active databases*

---

```
desmoines01:db2qas 21> db2 list active databases
```

```
Active Databases
```

```
Database name           = QAS  
Applications connected currently = 1  
Database path           = /db2path/db2qas/NODE0000/SQL00001/
```

---

## Connecting to an active database

To connect to an specific active database, you can use the **db2 connect to qas** command. You are then connected to this database.

## Configuration parameters for the current instance

The **db2 get dbm cfg** command lists all configuration parameters for the current instance. The result is shown in Example 12-43 on page 377.

*Example 12-43 Show partial DB2 instance configuration parameter*

---

```
desmoines01:db2qas 22> db2 get dbm cfg
```

Database Manager Configuration

```
Node type = Enterprise Server Edition with local and remote clients

Database manager configuration release level           = 0x0b00

CPU speed (millisec/instruction)                     (CPUSPEED) = 3.306409e-07
Communications bandwidth (MB/sec)                   (COMM_BANDWIDTH) = 1.000000e+02

Max number of concurrently active databases          (NUMDB) = 8
Federated Database System Support                   (FEDERATED) = NO
Transaction processor monitor name                   (TP_MON_NAME) =

Default charge-back account                          (DFT_ACCOUNT_STR) =

Java Development Kit installation path                (JDK_PATH) =
/db2/db2qas/sqllib/java/jdk64
. . .
```

---

## Configuration parameters for the current database

The **db2 get db cfg for qas** command lists all the parameters from the specific database. The result is shown in Example 12-44.

*Example 12-44 Partial list of configuration parameters for the SAP database QAS*

---

```
desmoines01:db2qas 23> db2 get db cfg for qas
```

Database Configuration for Database qas

```
Database configuration release level                 = 0x0b00
Database release level                             = 0x0b00
. . .
Backup pending                                     = NO

Database is consistent                             = NO
Rollforward pending                               = NO
Restore pending                                    = NO
. . .
Log retain for recovery status                     = NO
```

```

User exit for logging status                = YES
. . .
Path to log files                          =
/db2path/log_dir/NODE0000/
Overflow log path                          (OVERFLOWLOGPATH) =
Mirror log path                            (MIRRORLOGPATH) =
/db2path/archlog_dir/NODE0000/
First active log file                      = S0000003.LOG
Block log on disk full                     (BLK_LOG_DSK_FUL) = YES
Percent max primary log space by transaction (MAX_LOG) = 0
Num. of active log files for 1 active UOW(NUM_LOG_SPAN) = 0

Group commit count                        (MINCOMMIT) = 1
Percent log file reclaimed before soft chckpt (SOFTMAX) = 300
Log retain for recovery enabled            (LOGRETAIN) = OFF
User exit for logging enabled              (USEREXIT) = ON
. . .
First log archive method                   (LOGARCHMETH1) = USEREXIT
Options for logarchmeth1                   (LOGARCHOPT1) =
Second log archive method                  (LOGARCHMETH2) = OFF
Options for logarchmeth2                  (LOGARCHOPT2) =
Failover log archive path                 (FAILARCHPATH) =
Number of log archive retries on error     (NUMARCHRETRY) = 5
Log archive retry Delay (secs)             (ARCHRETRYDELAY) = 20
Vendor options                            (VENDOROPT) =
/db2/QAS/tdp_r3/vendor.env
. . .
TSM management class                      (TSM_MGMTCLASS) =
TSM node name                             (TSM_NODENAME) =
TSM owner                                 (TSM_OWNER) =
TSM password                              (TSM_PASSWORD) =
. . .

```

---

## Listing tablespaces information

To list all tablespaces from the current database, you can use the **db2 list tablespaces** command. The result is shown in Example 12-45 on page 379.

*Example 12-45 List of tablespaces from QAS database*

---

desmoines01:db2qas 5> db2 list tablespaces

Tablespaces for Current Database

Tablespace ID = 0  
Name = SYSCATSPACE  
Type = Database managed space  
Contents = All permanent data. Regular  
tablespace.  
State = 0x0000  
Detailed explanation:  
Normal

Tablespace ID = 3  
Name = PSAPTEMP16  
Type = System managed space  
Contents = System Temporary data  
State = 0x0000  
Detailed explanation:  
Normal

Tablespace ID = 4  
Name = SYSTOOLSTMPSPACE  
Type = System managed space  
Contents = User Temporary data  
State = 0x0000  
Detailed explanation:  
Normal

. . .

---

## Monitoring backup and restore

From the DB2 Command-Line Processor (CLP), you can monitor the backup execution. The **db2 list utilities** command can be used to list all utilities in execution. The result is shown in Example 12-46.

*Example 12-46 Monitoring DB2 database backup using the Tivoli Storage Manager API*

---

```
desmoines01:db2qas 6> db2 list utilities

ID                = 5
Type              = BACKUP
Database Name     = QAS
Partition Number  = 0
Description       = online db
Start Time        = 09/17/2008 15:01:47.897730
State             = Executing
Invocation Type   = User
Throttling:
  Priority         = Unthrottled
Progress Monitoring:
  Estimated Percentage Complete = 30
```

---

You can monitor the backup progress by looking at the Estimated Percentage Complete field in the **db2 list utilities** output.

## Listing backup history

This section lists the commands for listing the backup history.

### Listing the backup history from DB2

From the DB2 Command-Line Processor (CLP), you can list all backup history from the specific database. In addition, you can see the information from SQLCA at the end of the backup.

The command to list all backup history for the database QAS is **db2 list history backup all for db QAS**. The result is shown in Example 12-47 on page 381.



*Example 12-47 List of db2 list history backup for database QAS*

---

```
desmoines01:db2qas 20> db2 LIST HISTORY BACKUP ALL FOR DB QAS
```

```
          List History File for QAS
```

```
Number of matching file entries = 73
```

```
Op Obj Timestamp+Sequence Type Dev Earliest Log Current Log Backup ID
-----
B  D 20080808185040001 F D S0000000.LOG S0000000.LOG
```

```
-----
Contains 34 tablespace(s):
```

```
00001 SYSCATSPACE
00002 SYSTOOLSPACE
00003 QAS#DBD
00004 QAS#DBI
00005 QAS#FACTD
00006 QAS#FACTI
00007 QAS#EL700D
00008 QAS#EL700I
00009 QAS#CLUD
00010 QAS#CLUI
00011 QAS#LOADD
00012 QAS#LOADI
00013 QAS#SOURCED
00014 QAS#SOURCEI
00015 QAS#USER1D
00016 QAS#USER1I
00017 QAS#ES700D
00018 QAS#ES700I
```

---

To get the complete list of the database archivelog backup, you can use the **db2 list history archivelog all** command. The command output is similar to the **db2 list history backup** command listed in Example 12-47. The complete format of the **db2 list history** command can be found at the following address:

<http://publib.boulder.ibm.com/infocenter/db2luw/v9/index.jsp?topic=/com.ibm.db2.udb.admin.doc/doc/r0001991.htm>

## Listing backups from DB2 tables

For DB2 Version 9 and later, you can get the same information listed by the **db2 list history** from the DB2 table `sysibmadm.db_history`. (However, we strongly recommend that you use the available DB2 command.) This method is mostly used when you are required to process the information yourself (using your own tools) or create an customized report.

Example 12-48 shows an example of a command to list all the backups of a DB2 instance.

*Example 12-48 Sample SQL command to extract backup information from DB2 table*

---

```
db2 => select start_time, end_time , substr(comment,1,30) FROM
SYSIBMADM.DB_HISTORY WHERE OPERATION = 'B' AND OPERATIONTYPE = 'F'
```

START_TIME	END_TIME	3
20080808185040	20080808190533	DB2 BACKUP QAS OFFLINE
20080903155506	20080903160133	DB2 BACKUP QAS OFFLINE
20080916170618	20080916171958	DB2 BACKUP QAS OFFLINE
20080917101256	20080917101327	DB2 BACKUP QAS OFFLINE
20080917132110	20080917132111	DB2 BACKUP QAS OFFLINE
20080917143131	20080917143132	DB2 BACKUP QAS OFFLINE
20080917143647	20080917143648	DB2 BACKUP QAS OFFLINE
20080919103555	20080919103557	DB2 BACKUP QAS OFFLINE
20080919112156	20080919113723	DB2 BACKUP QAS OFFLINE
20080925163934	20080925163935	DB2 BACKUP QAS OFFLINE

10 record(s) selected.

---

The complete description of the `sysibmadm.db_history` table can be found at the following address:

<http://publib.boulder.ibm.com/infocenter/db2luw/v9/index.jsp?topic=/com.ibm.db2.udb.admin.doc/doc/r0022351.htm>

## Oracle basic operations

This appendix shows some basic Oracle operations commands. This appendix is particularly useful for users who are inexperienced with Oracle databases. The topics we discuss here include:

- ▶ “Oracle basic information” on page 384
- ▶ “Listing the Oracle database files” on page 387
- ▶ “Monitoring backup execution” on page 392

## Oracle basic information

This section shows how you can get information about Oracle instances in an AIX environment. This information can help you with problem determination or backup planning and implementation. For more detailed information, you should go to the Oracle Database Administration manual that comes with the product.

### Get information about the Oracle instance

There are many ways to discover Oracle instances on a UNIX-type server. Here we describe the most often used procedures.

#### Listing an instance list from oratab

Usually, the available Oracle instances are listed in the oratab file, which is found in the following locations:

- ▶ For AIX: /etc/oratab
- ▶ For other UNIX-type operating systems: /var/opt/oracle/oratab

Example B-1 shows our oratab file.

*Example: B-1 Sample oratab file*

---

```
# This file is used by ORACLE utilities.  It is created by root.sh
# and updated by the Database Configuration Assistant when creating
# a database.
# A colon, ':', is used as the field terminator.  A new line terminates
# the entry.  Lines beginning with a pound sign, '#', are comments.
#
# Entries are of the form:
#   $ORACLE_SID:$ORACLE_HOME:<N|Y>:
#
# The first and second fields are the system identifier and home
# directory of the database respectively.  The third field indicates
# to the dbstart utility that the database should, "Y", or should not,
# "N", be brought up at system boot time.
# Multiple entries with the same $ORACLE_SID are not allowed.
#
#
ORC:/oracle/ORC/102_64:Y
```

---

In Example B-1 on page 384, you can see the instance ORC defined for this server, which has the following characteristics:

- ▶ ORC; The Oracle instance name
- ▶ /oracle/ORC/102\_64: The Oracle Home directory
- ▶ Y: This flag should be Y (for Yes) or N (for No). It indicates to the UNIX boot startup/shutdown procedures to start or stop the instance during the system startup or shutdown.

## Checking instance execution

Usually you can connect to the instance to check and see if it is running properly. You can list the UNIX processes and look for the Oracle processes related to the instance by using the `ps -ef|grep ORC` command. The result is shown in Example B-2.

*Example: B-2 Listing of Oracle processes*

---

```
charger01:orcadm 5> ps -ef|grep ORC

 oraorc 471238      1  0   Sep 29   -  0:01
/oracle/ORC/102_64/bin/tnslsnr LISTENER -inherit
 orcadm 483382 1319090  0 15:15:22 pts/0  0:00 grep ORC
 orcadm 553180      1  0   Sep 29   -  0:02 ora_mman_ORC
 oraorc 585788      1  0   Sep 25   -  0:00 -csh -c
/usr/sap/ORC/SYS/exe/run/acsprole -p tsmacsora tdpr3ora64
 orcadm 610432      1  0   Sep 29   -  0:03 ora_mmon_ORC
 orcadm 618662      1  0   Sep 29   -  0:13 ora_ckpt_ORC
 oraorc 667784 1122376  0 15:06:18   -  0:00 brbackup -c -u / -t
ONLINE_CONS -m FULL -p /oracle/ORC/102_64/dbs/initORC.sap
 orcadm 671824      1  0   Sep 29   -  0:00 ora_reco_ORC
 orcadm 676072      1  0   Sep 29   -  0:00 ora_arc0_ORC
 oraorc 704760 237704  9 15:06:23   -  0:30 oracleORC
(DESCRIPTION=(LOCAL=YES)(ADDRESS=(PROTOCOL=beq)))
 orcadm 708804      1  0   Sep 29   -  0:24 ora_cjq0_ORC
 orcadm 716824      1  0   Sep 29   -  0:16 ora_mmn1_ORC
 orcadm 766102      1  0   Sep 29   -  0:13 ora_smon_ORC
 orcadm 852118      1  0   Sep 29   -  0:00 ora_q000_ORC
 orcadm 864462      1  0   Sep 29   -  0:02 ora_lgwr_ORC
 oraorc 954594      1  0 15:06:21   -  0:00
/usr/sap/ORC/SYS/exe/run/brconnect -R 667784
 oraorc 962572 237704  0 15:06:23   -  0:00 oracleORC
(DESCRIPTION=(LOCAL=YES)(ADDRESS=(PROTOCOL=beq)))
 orcadm 983078      1  0   Sep 29   -  0:00 ora_q001_ORC
 oraorc 999442 237704  0 15:06:23   -  0:00 oracleORC
(DESCRIPTION=(LOCAL=YES)(ADDRESS=(PROTOCOL=beq)))
```

```

orcadm 1011898      1  0  Sep 29   -  0:13 ora_pmon_ORC
orcadm 1016014      1  0  Sep 29   -  0:01 ora_arc1_ORC
oraorc 1052820  585788  0  Sep 25   -  0:17
/usr/sap/ORC/SYS/exe/run/acsprole -p tsmacsora tdpr3ora64
orcadm 1089664      1  0  Sep 29   -  0:01 ora_psp0_ORC
orcadm 1114122      1  0  Sep 29   -  0:03 ora_dbw0_ORC
orcadm 1257704      1  0  Sep 29   -  0:00 ora_qmnc_ORC

```

---

In the list shown in Example B-2 on page 385, you can see many Oracle processes related to the instance ORC. The following list shows the most important processes:

- ▶ ora\_smon
- ▶ ora\_reco
- ▶ ora\_pmon
- ▶ ora\_lgwr
- ▶ ora\_dbw

This is a good indication that this instance has started. You can also see the Oracle owner in this list (orcadm, in this case).

## Connecting to the Oracle instance

There are several ways to connect to an Oracle instance. We describe a method to connect using a UNIX console. You must sign in as root or use the Oracle owner account. From the UNIX console, you can choose the specific instance to which to connect. This can be done using the **oraenv** command. The result looks like Example B-3.

*Example: B-3 Sample oraenv command to use ORC as default instance*

```

charger01:orcadm 12> oraenv
ORACLE_SID = [ORC] ? ORC

```

---

The **oraenv** command defines and sets all required Oracle environment variables. The following is the list of most common Oracle environment variables:

<b>ORACLE_SID</b>	Defines the current Oracle instance.
<b>ORACLE_HOME</b>	Defines the home directory of the Oracle software.
<b>TNS_ADMIN</b>	Defines where you can find all configuration files related to the database connectivity (tnsnames.ora or listener.ora).

Now you are ready to connect to the Oracle instance, which can be done by using the **sqlplus** command, as shown in Example B-4 on page 387.

*Example: B-4 Connecting to Oracle instance using sqlplus command*

---

```
charger01:orcadm 7> sqlplus /nolog
SQL*Plus: Release 10.2.0.2.0 - Production on Wed Oct 1 15:42:54 2008
Copyright (c) 1982, 2005, Oracle. All Rights Reserved.
```

```
SQL> connect / as sysdba
Connected.
```

---

After you connect to the instance, you can check the current status of the Oracle instance, as shown in Example B-5.

*Example: B-5 Sample Oracle commands to check the instance status*

---

```
SQL> show sga
Total System Global Area 4714397696 bytes
Fixed Size                2083728 bytes
Variable Size             2365588592 bytes
Database Buffers         2332033024 bytes
Redo Buffers              14692352 bytes
SQL> select instance_name, version, startup_time, database_status,
host_name from v$instance;
INSTANCE_NAME VERSION          STARTUP_TIME  DATABASE_STATUS  HOST_NAME
-----
ORC            10.2.0.2.0      29-SEP-08    ACTIVE            charger01
```

---

## Listing the Oracle database files

The Oracle database files are the most important component for data protection strategy. The following sections show sample SQL commands to list the most important Oracle database files.

## Oracle control files

You can get the control file list from the configuration file (`init.ora`) and from the `v$controlfile` table. Example B-6 shows a sample SQL command to list all control files.

*Example: B-6 Sample SQL command to list the Oracle control files*

---

```
SQL> select name from v$controlfile;
```

```
NAME
```

```
-----  
/oracle/ORC/origlogA/cntrl/cntrlORC.dbf  
/oracle/ORC/origlogB/cntrl/cntrlORC.dbf  
/oracle/ORC/sapdata1/cntrl/cntrlORC.dbf
```

---

## Oracle redo log files

You can get the redolog file list from the `v$logfile` table. Example B-7 shows a sample SQL command to list all database redolog files.

*Example: B-7 Sample redolog file list*

---

```
SQL> select member from v$logfile;
```

```
MEMBER
```

```
-----  
/oracle/ORC/origlogA/log_g11m1.dbf  
/oracle/ORC/mirrlogA/log_g11m2.dbf  
/oracle/ORC/origlogB/log_g12m1.dbf  
/oracle/ORC/mirrlogB/log_g12m2.dbf  
/oracle/ORC/origlogA/log_g13m1.dbf  
/oracle/ORC/mirrlogA/log_g13m2.dbf  
/oracle/ORC/origlogB/log_g14m1.dbf  
/oracle/ORC/mirrlogB/log_g14m2.dbf
```

```
8 rows selected.
```

---

## Oracle tablespace list

The Oracle tablespace list can be found in the table `v$tablespace` or `dba_tablespaces`. Example B-8 on page 389 shows sample SQL command to list all tablespaces.



Example: B-8 Sample tablespace list

```
SQL> select
  2  b.tablespace_name name,
  3  kbytes_alloc kbytes,
  4  kbytes_alloc-nvl(kbytes_free,0) used,
  5  nvl(kbytes_free,0) free,
  6  largest,
  7  trunc(((kbytes_alloc-kbytes_free)/kbytes_alloc)*100,1) pct_used,
  8  c.contents
  9  from
 10  ( select
 11      trunc(sum(bytes)/1024/1024) Kbytes_free,
 12      trunc(max(bytes)/1024/1024) largest,
 13      tablespace_name
 14  from
 15      sys.dba_free_space
 16  group by
 17      tablespace_name
 18  ) a,
 19  ( select
 20      trunc(sum(bytes)/1024/1024) Kbytes_alloc,
 21      tablespace_name
 22  from
 23      sys.dba_data_files
 24  group by
 25      tablespace_name
 26  ) b,
 27  dba_tablespaces c
 28  where
 29  a.tablespace_name (+) = b.tablespace_name
 30  and a.tablespace_name = c.tablespace_name
 31  /
```

NAME	KBYTES	USED	FREE	LARGEST	PCT_USED	CONTENTS
SYSTEM	840	839	1	0	99.8	PERMANENT
PSAPSR3USR	20	2	18	18	10	PERMANENT
PSAPSR3DB	5000	1611	3389	1455	32.2	PERMANENT
PSAPSR3	40000	33139	6861	855	82.8	PERMANENT
PSAPUNDO	4180	123	4057	1353	2.9	UNDO
PSAPSR3700	50080	39176	10904	1512	78.2	PERMANENT
SYSAUX	220	182	38	3	82.7	PERMANENT

7 rows selected.

## Oracle data file list

You can list all database data files from table v\$datafile or dba\_data\_files. Example B-9 shows one sample SQL command to list all data files owned by the Oracle database.

*Example: B-9 Sample list of Oracle data files*

```
SQL> select
2  tablespace_name,
3  substr(file_name, 1,45) fname,
4  trunc(bytes/1024/1024) sizemb
5  from dba_data_files
6  /
```

---

TABLESPACE_NAME	FNAME	SIZEMB
SYSTEM	/oracle/ORC/sapdata1/system_1/system.data1	840
PSAPUNDO	/oracle/ORC/sapdata3/undo_1/undo.data1	4180
SYSAUX	/oracle/ORC/sapdata1/sysaux_1/sysaux.data1	220
PSAPSR3	/oracle/ORC/sapdata1/sr3_1/sr3.data1	2000
PSAPSR3	/oracle/ORC/sapdata1/sr3_2/sr3.data2	2000
PSAPSR3	/oracle/ORC/sapdata1/sr3_3/sr3.data3	2000
PSAPSR3	/oracle/ORC/sapdata1/sr3_4/sr3.data4	2000
.	.	.

---

## Oracle archived log list

The archived log destination is registered in the Oracle parameter table. You can get the destination list by running the **show parameter log\_archive\_dest** command or from the table v\$parameter. Example B-10 shows both examples.

*Example: B-10 Sample commands to discover the archivelog destination*

```
SQL> show parameter log_archive_dest
```

---

NAME	TYPE	VALUE
log_archive_dest	string	/oracle/ORC/oraarch/ORCarch
log_archive_dest_1	string	
log_archive_dest_10	string	
log_archive_dest_2	string	
log_archive_dest_3	string	
log_archive_dest_4	string	

log_archive_dest_5	string	
log_archive_dest_6	string	
log_archive_dest_7	string	
log_archive_dest_8	string	
log_archive_dest_9	string	
log_archive_dest_state_1	string	enable
log_archive_dest_state_10	string	enable
log_archive_dest_state_2	string	enable
log_archive_dest_state_3	string	enable
log_archive_dest_state_4	string	enable
log_archive_dest_state_5	string	enable
log_archive_dest_state_6	string	enable
log_archive_dest_state_7	string	enable
log_archive_dest_state_8	string	enable
log_archive_dest_state_9	string	enable

SQL> **select name||'='||value logdest from v\$parameter where name like 'log\_archive\_dest%';**

LOGDEST

---

```

log_archive_dest=/oracle/OCR/oraarch/OCArch
log_archive_dest_1=
log_archive_dest_2=
log_archive_dest_3=
log_archive_dest_4=
log_archive_dest_5=
log_archive_dest_6=
log_archive_dest_7=
log_archive_dest_8=
log_archive_dest_9=
log_archive_dest_10=
log_archive_dest_state_1=enable
log_archive_dest_state_2=enable
log_archive_dest_state_3=enable
log_archive_dest_state_4=enable
log_archive_dest_state_5=enable
log_archive_dest_state_6=enable
log_archive_dest_state_7=enable
log_archive_dest_state_8=enable
log_archive_dest_state_9=enable
log_archive_dest_state_10=enable

```

21 rows selected.

---

In the example shown in Example B-10 on page 390, the archivelog destination is located in directory `/oracle/ORC/oraarch/ORCarch`.

**Note:** Usually in the production environment, there is more than one archivelog destination, which is listed as a best practice in several Oracle publications.

## Monitoring backup execution

In some specific cases, you have to go to the Oracle database to check if backups are running or are stopped for any reason. The most common procedure is to check the following tables:

- ▶ `v$session`
- ▶ `v$session_wait`
- ▶ `v$session_longops`

### Listing `v$session_wait`

From this table, you can see in real time all session waits and then decide what is the next step. The SQL command in Example B-11 shows the real time execution status.

*Example: B-11 Sample output from `v$session_wait` table*

---

```
SQL> select
 2  s.sid,
 3  w.event event,
 4  w.P1TEXT,
 5  w.P1,
 6  w.P1RAW ,
 7  w.P2TEXT ,
 8  w.WAIT_TIME,
 9  w.SECONDS_IN_WAIT,
10  w.state state
11 from
12  v$session s,
13  v$session_wait w,
14  v$process p
15 where s.sid = w.sid
16  and w.event not like 'SQL*Net message'
17  and w.event <> 'rdbms ipc message'
18  and s.paddr = p.addr
```

SID	event	P1	P1RAW	P2TEXT	P2	WAIT_TIME	SECONDS_IN_WAIT	P1TEXT	state
70	Streams AQ: qmn slave idle wait	0	00		0	0	142976		WAITING
71	Streams AQ: waiting for time management or cleanup tasks	0	00		0	0	173108		WAITING
74	Streams AQ: qmn coordinator idle wait	0	00		0	0	173104		WAITING
90	smon timer							sleep	
time	300 0000000000012C failed				0	0		31511	
	WAITING								
96	pmon timer								
duration	300 0000000000012C				0	0			
	173119 WAITING								

5 rows selected.

### Listing v\$session\_longops

Usually RMAN keeps the backup execution progress in this database view. You are able to see the backup progress and estimate the backup elapsed time. Example B-12 shows a sample output from this view.

*Example: B-12 Sample output from v\$session\_longops*

```
SQL> Select
2   a.sid,
3   a.serial#,
4   b.username,
5   to_char(a.start_time, 'DD/MM HH24:MI') "start_time",
6   a.time_remaining,
7   a.elapsed_seconds,
8   substr(a.message,1,160) message
9 from
10  v$session_longops a,
11  v$session b
12 where
13   a.sid = b.sid and a.time_remaining > 0
14 /
```

SID	SERIAL#	USERNAME	start_time
TIME_REMAINING	ELAPSED_SECONDS	MESSAGE	
82	450	SYS	01/10 01:35
1	3	RMAN: aggregate input: backup 20: 23640965 out of 23640965 Blocks done	
82	593	SYS	01/10 07:35
1	3	RMAN: aggregate input: backup 20: 23640965 out of 23640965 Blocks done	
82	348	SYS	30/09 15:12
750	4750	RMAN: aggregate output: backup 20: 6475744 out of 6475744 Blocks done	

# Abbreviations and acronyms

<b>ABAP</b>	Advanced Business Application Programming	<b>COLD</b>	Computer Output on Laser Disc
<b>ACS</b>	Advanced Copy Services	<b>CPU</b>	Central Processing Unit
<b>ADSM</b>	Adstar Storage Manager	<b>CRM</b>	Customer Relationship Management
<b>AIX</b>	Advanced Interactive eXecutive	<b>CTS</b>	Change and Transport System
<b>API</b>	Application Programming Interface	<b>DB2</b>	Database 2
<b>ASCII</b>	American Standard Code for Information Interchange™	<b>DBA</b>	Database Administrator
<b>ASCS</b>	ABAP SAP Central Services	<b>DBID</b>	Database ID
<b>BAPI</b>	Business Application Programming Interface	<b>DBMS</b>	Database Management System
<b>BBP</b>	Business-to-business Procurement	<b>DLL</b>	Dynamic Link Library
<b>BIA</b>	Business Impact Assessment	<b>DMS</b>	Document Management System
<b>BIOS</b>	Basic Input Output Services	<b>DPW</b>	Data Protection Window
<b>BMR</b>	Bare Metal Restore	<b>DRDA</b>	Distributed Relational Database Access
<b>CAD</b>	Computer Aided Design	<b>EBP</b>	Enterprise Buyer Professional
<b>CAF</b>	Composite Application Framework	<b>ECC</b>	ERP Central Component
<b>CCMS</b>	Computing Center Management System	<b>EOB</b>	End of Block
<b>CD-ROM</b>	Compact Disc Read Only Memory	<b>ERP</b>	Enterprise Resource Planning
<b>CFS</b>	Cluster File System	<b>ESCON</b>	Enterprise System Connection
<b>CICS</b>	Customer Information Control System	<b>ESE</b>	Enterprise Server Edition
<b>CIM</b>	Common Information Model	<b>ESS</b>	Enterprise Storage System
<b>CIMOM</b>	CIM Object Manager	<b>FTP</b>	File Transfer Protocol
<b>CLI</b>	Command-Line Interface	<b>GLVM</b>	Geographic Logical Volume Manager
<b>CLP</b>	Command-Line Processor	<b>GPFS</b>	General Parallel File System
<b>COBIT</b>	Control Objectives for Information Technology	<b>GRC</b>	Governance, Risk and Compliance
		<b>GUI</b>	Graphical User Interface

<b>HACMP</b>	High Availability Cluster Multi Processing	<b>LVM</b>	Logical Volume Manager
<b>HADR</b>	High Availability Disaster Recovery	<b>MAA</b>	Maximum Availability Architecture
<b>HAGEO</b>	High Availability Geographic cluster	<b>MMS</b>	Media Management System
<b>HBA</b>	Host Bus Adapter	<b>MSCS</b>	Microsoft Cluster Services
<b>HDR</b>	High availability Data Replication	<b>MVS</b>	Multiple Virtual Storage
<b>HTML</b>	Hypertext Markup Language	<b>NFS</b>	Network File System
<b>HTTP</b>	Hypertext Transfer Protocol	<b>NWDI</b>	NetWeaver Development Infrastructure
<b>HTTPS</b>	HTTP Secure	<b>ODBC</b>	Open Database Connectivity
<b>IBM</b>	International Business Machine Corporation	<b>OLE</b>	Object Linking and Embedding
<b>ICM</b>	Internet Communication Manager	<b>PAM</b>	Pluggable Authentication Module
<b>IGS</b>	Internet Graphic Service	<b>PKCS7</b>	Public Key Cryptography Standard 7
<b>IIC</b>	Information Integrator for Content	<b>PLM</b>	Product Lifecycle Management
<b>ISV</b>	Independent Software Vendor	<b>PPRC</b>	Peer to Peer Remote Copy
<b>ITIL</b>	Information Technology Infrastructure Library	<b>RAC</b>	Real Application Cluster
<b>ITS</b>	Internet Transaction Server	<b>RAID</b>	Redundant Array of Independent Disks
<b>ITSO</b>	International Technical Support Organization	<b>RAM</b>	Random Access Memory
<b>J2EE</b>	Java 2 Enterprise Edition	<b>RDBMS</b>	Relational Database Management System
<b>JAAS</b>	Java Authorization and Authentication System	<b>RFC</b>	Remote Function Call
<b>JDBC</b>	Java Database Connectivity	<b>RFID</b>	Radio Frequency Identifier
<b>JDO</b>	Java Data Objects	<b>RMAN</b>	Recovery Manager
<b>JFS</b>	Journalled File System	<b>ROG</b>	Recovery Object Granularity
<b>JPA</b>	Java Persistence API	<b>RPO</b>	Recovery Point Objective
<b>JRE</b>	Java Runtime Environment	<b>RTG</b>	Recovery Time Granularity
<b>LAN</b>	Local Area Network	<b>RTO</b>	Recovery Time Objective
<b>LGWR</b>	Log Writer	<b>SAML</b>	Security Assertion Markup Language
<b>LTO</b>	Linear Tape Open	<b>SAN</b>	Storage Area Network
<b>LUN</b>	Logical Unit Number	<b>SAP</b>	System Application
<b>LUW</b>	Logical Unit of Work	<b>SAPR</b>	System Assurance Product Review



<b>SBT</b>	Secure Backup to Tape	<b>TSA</b>	Tivoli System Automation
<b>SCA</b>	Software Component Archives	<b>TSM</b>	Tivoli Storage Manager
<b>SCM</b>	Supply Chain Management	<b>UDB</b>	Universal Database
<b>SCS</b>	SAP Central Services	<b>UPS</b>	Uninterruptible Power Supply
<b>SCSI</b>	Small Computer System Interface	<b>URL</b>	Uniform Resource Locator
<b>SDA</b>	Software Deployment Archives	<b>UUID</b>	Universally Unique Identifier
<b>SDD</b>	Subsystem Device Driver	<b>VDI</b>	Virtual Device Interface
<b>SDM</b>	Software Deployment Manager	<b>VSS</b>	Virtual Source Safe
<b>SEM</b>	Strategic Enterprise Management	<b>WAN</b>	Wide Area Network
<b>SGA</b>	System Global Area	<b>WBEM</b>	Web Based Enterprise Management
<b>SLCM</b>	Solution Lifecycle Management	<b>WSSec</b>	Web Services Security
<b>SLP</b>	Service Location Protocol	<b>XBSA</b>	X/Open Backup Services API
<b>SMIT</b>	System Management Interface Tools		
<b>SMTP</b>	Simple Mail Transfer Protocol		
<b>SNC</b>	Secure Network Communication		
<b>SOA</b>	Service-Oriented Architecture		
<b>SPOF</b>	Single Point of Failure		
<b>SQL</b>	Structured Query Language		
<b>SQLJ</b>	SQL Java		
<b>SRM</b>	Supplier Relationship Management		
<b>SSL</b>	Secure Socket Layer		
<b>SVC</b>	SAN Volume Controller		
<b>TCO</b>	Total Cost of Ownership		
<b>TCP</b>	Transmission Control Protocol		
<b>TCP/IP</b>	Transmission Control Protocol/Internet Protocol		
<b>TDI</b>	Tablespace Definition Information		
<b>TDP</b>	Tivoli Data Protection		

Archived

# Related publications

The publications listed in this section are considered particularly suitable for a more detailed discussion of the topics covered in this book.

## IBM Redbooks

For information about ordering these publications, see “How to get Redbooks” on page 408. Note that some of the documents referenced here may be available in softcopy only.

- ▶ *Certification Study Guide: IBM Tivoli Storage Manager V5.4*, SG24-7489
- ▶ *Deployment Guide Series: IBM Tivoli Storage Manager V5.5*, SG24-7379
- ▶ *Get More Out of Your SAN with IBM Tivoli Storage Manager*, SG24-6687
- ▶ *IBM Tivoli Storage Manager for Advanced Copy Services*, SG24-7474
- ▶ *IBM Tivoli Storage Manager: Bare Machine Recovery for AIX with SYSBACK*, REDP-3705
- ▶ *IBM Tivoli Storage Manager: Building a Secure Environment*, SG24-7505
- ▶ *IBM Tivoli Storage Management Concepts*, SG24-4877
- ▶ *IBM Tivoli Storage Manager Implementation Guide*, SG24-5416
- ▶ *IBM Tivoli Storage Manager Versions 5.4 and 5.5 Technical Guide*, SG24-7447
- ▶ *Infrastructure Solutions: Design, Manage, and Optimize a 60 TB SAP NetWeaver Business Intelligence Data Warehouse*, SG24-7385
- ▶ *R/3 Data Management Techniques Using Tivoli Storage Manager*, SG24-5743

## Other publications

These publications are also relevant as further information sources:

- ▶ Tivoli Storage Manager client publications
  - *IBM Tivoli Storage Manager for HSM for Windows Administration Guide*, SC32-1773

- *IBM Tivoli Storage Manager for Macintosh: Backup-Archive Clients Installation and User's Guide*, SC32-0143
- *IBM Tivoli Storage Manager for NetWare: Backup-Archive Clients Installation and User's Guide*, SC32-0144
- *IBM Tivoli Storage Manager for Space Management for UNIX and Linux: User's Guide*, SC32-0148
- *IBM Tivoli Storage Manager for UNIX and Linux: Backup-Archive Clients Installation and User's Guide*, SC32-0145
- *IBM Tivoli Storage Manager Using the Application Program Interface*, SC32-0147
- *IBM Tivoli Storage Manager for Windows: Backup-Archive Clients Installation and User's Guide*, SC32-0146
- ▶ Tivoli Storage Manager Data Protection publications
  - *IBM Tivoli Storage Manager for Advanced Copy Services: Data Protection for Snapshot Devices for DB2 Installation and User's Guide*, SC33-8330
  - *IBM Tivoli Storage Manager for Advanced Copy Services: Data Protection for Snapshot Devices for SAP Installation and User's Guide for Oracle*, SC33-8207
  - *IBM Tivoli Storage Manager for Advanced Copy Services: Data Protection for WebSphere Application Server Installation and User's Guide*, SC32-9075
  - *IBM Tivoli Storage Manager for Databases: Data Protection for Informix Installation and User's Guide*, SH26-4095
  - *IBM Tivoli Storage Manager for Databases: Data Protection for Microsoft SQL Server Installation and User's Guide*, SC32-9059
  - *IBM Tivoli Storage Manager for Databases: Data Protection for Oracle for UNIX and Linux Installation and User's Guide*, SC32-9064
  - *IBM Tivoli Storage Manager for Databases: Data Protection for Oracle for Windows Installation and User's Guide*, SC32-9065
  - *IBM Tivoli Storage Manager for Enterprise Resource Planning: Data Protection for SAP Installation and User's Guide for DB2*, SC33-6341
  - *IBM Tivoli Storage Manager for Enterprise Resource Planning: Data Protection for SAP Installation and User's Guide for Oracle*, SC33-6340
  - *IBM Tivoli Storage Manager for Hardware: Data Protection for Enterprise Storage Server for DB2 UDB Installation and User's Guide*, SC32-9060
  - *IBM Tivoli Storage Manager for Hardware: Data Protection for Snapshot Devices for Oracle Installation and User's Guide*, GC32-1772

- ▶ Tivoli Storage Manager server publications
  - *IBM Tivoli Storage Manager for AIX Administrator's Guide*, SC32-0117
  - *IBM Tivoli Storage Manager for AIX Administrator's Reference*, SC32-0123
  - *IBM Tivoli Storage Manager for AIX Installation Guide*, GC23-5969
  - *IBM Tivoli Storage Manager for HP-UX Administrator's Guide*, SC32-0118
  - *IBM Tivoli Storage Manager for HP-UX Administrator's Reference*, SC32-0124
  - *IBM Tivoli Storage Manager for HP-UX Installation Guide*, GC23-5970
  - *IBM Tivoli Storage Manager for Linux Administrator's Guide*, SC32-0119
  - *IBM Tivoli Storage Manager for Linux Administrator's Reference*, SC32-0125
  - *IBM Tivoli Storage Manager for Linux Installation Guide*, GC23-5971
  - *IBM Tivoli Storage Manager Messages*, SC32-0140
  - *IBM Tivoli Storage Manager Performance Tuning Guide*, SC32-0141
  - *IBM Tivoli Storage Manager Problem Determination Guide*, SC32-0142
  - *IBM Tivoli Storage Manager for Sun Solaris Administrator's Guide*, SC32-0120
  - *IBM Tivoli Storage Manager for Sun Solaris Administrator's Reference*, SC32-0126
  - *IBM Tivoli Storage Manager for Sun Solaris Installation Guide*, GC23-5972
  - *IBM Tivoli Storage Manager for System Backup and Recovery Installation and User's Guide*, SC32-6543
  - *IBM Tivoli Storage Manager for Windows Administrator's Guide*, SC32-0121
  - *IBM Tivoli Storage Manager for Windows Administrator's Reference*, SC32-0127
  - *IBM Tivoli Storage Manager for Windows Installation Guide*, GC23-5973
- ▶ Tivoli Storage Manager storage agent publications
  - *IBM Tivoli Storage Manager for SAN for AIX Storage Agent User's Guide*, SC32-0129
  - *IBM Tivoli Storage Manager for SAN for HP-UX Storage Agent User's Guide*, SC32-0130
  - *IBM Tivoli Storage Manager for SAN for Linux Storage Agent User's Guide*, SC32-0131

- *IBM Tivoli Storage Manager for SAN for Sun Solaris Storage Agent User's Guide*, SC32-0132
- *IBM Tivoli Storage Manager for SAN for Windows Storage Agent User's Guide*, SC32-0133

## Online resources

These Web sites are also relevant as further information sources:

- ▶ IBM Web pages
  - ADINT/TSM - Overview  
[http://www-05.ibm.com/de/entwicklung/adint\\_tsm/index.html](http://www-05.ibm.com/de/entwicklung/adint_tsm/index.html)
  - *ADINT/TSM User Guide*  
[http://www-05.ibm.com/de/entwicklung/adint\\_tsm/download/user\\_guide.pdf](http://www-05.ibm.com/de/entwicklung/adint_tsm/download/user_guide.pdf)
  - AIX Device Drivers for System Storage Tape  
<http://www-01.ibm.com/support/docview.wss?rs=543&tc=STCVQ6R&uid=sg1S4000093>
  - BackOM command reference page  
<http://publib.boulder.ibm.com/infocenter/tivihelp/v1r1/index.jsp?topic=/com.ibm.itsmerp.doc/fbrd000050.htm>
  - Data Protection for SAP - Oracle: installation problem resolution page  
<http://publib.boulder.ibm.com/infocenter/tivihelp/v1r1/index.jsp?topic=/com.ibm.itsmerp.doc/fbro000074.htm>
  - *Data Protection for SAP Installation and User's Guide for DB2*  
<http://publib.boulder.ibm.com/infocenter/tivihelp/v1r1/index.jsp?topic=/com.ibm.itsmerp.doc/fbrd0000.htm>
  - *Data Protection for SAP Installation and User's Guide for DB2 - Troubleshooting*  
<http://publib.boulder.ibm.com/infocenter/tivihelp/v1r1/topic/com.ibm.itsmerp.doc/fbrd000078.htm>
  - Data Protection for SAP release notes  
[http://publib.boulder.ibm.com/infocenter/tivihelp/v1r1/index.jsp?topic=/com.ibm.itsmreadme.doc\\_5.5/relnote\\_erp550.html](http://publib.boulder.ibm.com/infocenter/tivihelp/v1r1/index.jsp?topic=/com.ibm.itsmreadme.doc_5.5/relnote_erp550.html)

- DB2 - BACKUP DATABASE command  
<http://publib.boulder.ibm.com/infocenter/db21uw/v9/index.jsp?topic=/com.ibm.db2.udb.admin.doc/doc/r0001933.htm>
- DB2 - Configuring Tivoli Storage Manager client  
<http://publib.boulder.ibm.com/infocenter/db21uw/v9/index.jsp?topic=/com.ibm.db2.udb.admin.doc/doc/t0024706.htm>
- DB2 - Considerations for using Tivoli Storage Manager  
<http://publib.boulder.ibm.com/infocenter/db21uw/v9/index.jsp?topic=/com.ibm.db2.udb.admin.doc/doc/c0024708.htm>
- DB2 - DB\_HISTORY view  
<http://publib.boulder.ibm.com/infocenter/db21uw/v9/index.jsp?topic=/com.ibm.db2.udb.admin.doc/doc/r0022351.htm>
- DB2 - Developing a backup and recovery strategy  
<http://publib.boulder.ibm.com/infocenter/db21uw/v9/index.jsp?topic=/com.ibm.db2.udb.admin.doc/doc/c0005945.htm>
- DB2 - LIST HISTORY command  
<http://publib.boulder.ibm.com/infocenter/db21uw/v9/index.jsp?topic=/com.ibm.db2.udb.admin.doc/doc/r0001991.htm>
- DB2 CommonStore for SAP Version 8.3 manuals  
[http://www-01.ibm.com/support/docview.wss?rs=51&context=SS6QJP&dc=DA400&uid=swg27007919&loc=en\\_US&cs=UTF-8&lang=en&rss=ct51db2](http://www-01.ibm.com/support/docview.wss?rs=51&context=SS6QJP&dc=DA400&uid=swg27007919&loc=en_US&cs=UTF-8&lang=en&rss=ct51db2)
- DB2 Database for Linux, UNIX, and Windows documentation page  
<http://publib.boulder.ibm.com/infocenter/db21uw/v9/index.jsp?topic=/com.ibm.db2.udb.doc/welcome.htm>
- DB2 Universal Database - tsm\_nodename parameter  
<http://publib.boulder.ibm.com/infocenter/db21uw/v9/index.jsp?topic=/com.ibm.db2.udb.admin.doc/doc/r0000343.htm>
- DB2 Universal Database - db2adutl command  
<http://publib.boulder.ibm.com/infocenter/db21uw/v9/index.jsp?topic=/com.ibm.db2.udb.admin.doc/doc/r0002077.htm>
- DB2 V8.2 High Availability Disaster Recovery (HADR) in an SAP implementation  
<http://www.ibm.com/developerworks/db2/library/techarticle/dm-0508zeng/>

- Enterprise Solution Development Data Protection  
<http://www-05.ibm.com/de/entwicklung/esd/>
- IBM - CommonStore for SAP - Software  
<http://www-01.ibm.com/software/data/commonstore/sap/>
- IBM - IBM FlashCopy Cloning - Overview  
<http://www-05.ibm.com/de/entwicklung/esd/fcc/>
- IBM - Tivoli Storage Manager for Advanced Copy Services  
<http://www-01.ibm.com/software/tivoli/products/storage-mgr-advanced-copy-services/>
- IBM CommonStore for SAP manual  
<ftp://ftp.software.ibm.com/software/data/cmgr/pdf/cssapv82.pdf>
- *IBM DB2 CommonStore for SAP Client Installation and User's Guide*  
<http://publibfp.boulder.ibm.com/epubs/pdf/h1267433.pdf>
- *IBM DB2 CommonStore for SAP Server Installation and User's Guide*  
<http://publibfp.boulder.ibm.com/epubs/pdf/h1267443.pdf>
- IBM Enterprise Storage Server family: Overview  
<http://www.ibm.com/servers/storage/disk/ess/index.html>
- IBM PowerHA for AIX (HACMP)  
<http://www-03.ibm.com/systems/p/advantages/ha/index.html>
- IBM PowerHA/XD for AIX (HACMP/XD)  
<http://www-03.ibm.com/systems/p/advantages/ha/disaster/tech.html>
- IBM Storage Device Driver download page  
<ftp://service.boulder.ibm.com/storage/devdrv>
- IBM Support for CIM Agent for DS Open (API)  
<http://www.ibm.com/servers/storage/support/software/cimsoapi/installing.html>
- IBM System Storage DS6000: Overview  
<http://www.ibm.com/servers/storage/disk/ds6000/index.html>
- IBM System Storage DS8000 Turbo  
<http://www.ibm.com/servers/storage/disk/ds8000/index.html>
- IBM System Storage SAN Volume Controller: Overview  
<http://www.ibm.com/servers/storage/software/virtualization/svc/index.html>



- IBM Tivoli Storage Manager - Overview  
<http://www.ibm.com/software/sysmgmt/products/support/IBMTivoliStorageManager.html>
- IBM Tivoli Storage Manager for Databases - Overview  
<http://www-01.ibm.com/software/sysmgmt/products/support/IBMTivoliStorageManagerforDatabases.html>
- IBM Tivoli Storage Manager for Enterprise Resource Planning - Overview  
<http://www.ibm.com/software/sysmgmt/products/support/IBMTivoliStorageManagerforEnterpriseResourcePlanning.html>
- IBM Tivoli Storage Manager for ERP documentation page  
<http://publib.boulder.ibm.com/infocenter/tivihelp/v1r1/index.jsp?toc=/com.ibm.itsmerp.doc/toc.xml>
- IBM Tivoli Storage Manager for SAN installation page  
<http://publib.boulder.ibm.com/infocenter/tivihelp/v1r1/index.jsp?topic=/com.ibm.itsmagent.doc/anrlst5432.htm>
- IBM Tivoli Storage Manager maintenance download page  
<ftp://index.storsys.ibm.com/tivoli-storage-management/maintenance/>
- IBM Tivoli Storage Manager Release Notes  
[http://publib.boulder.ibm.com/infocenter/tivihelp/v1r1/topic/com.ibm.itsmreadme.doc\\_5.5/relnotes.html](http://publib.boulder.ibm.com/infocenter/tivihelp/v1r1/topic/com.ibm.itsmreadme.doc_5.5/relnotes.html)
- IBM Tivoli System Automation for Multiplatforms documentation page  
<http://publib.boulder.ibm.com/tividd/td/IBMTivoliSystemAutomationforMultiplatforms3.1.html>
- IBM TotalStorage support: Search for host bus adapters, firmware, and drivers  
<http://www-03.ibm.com/systems/support/storage/config/hba/index.ws>
- Tivoli Storage Manager Client Requirements on IBM AIX  
[http://www-01.ibm.com/support/docview.wss?rs=663&context=SSGSG7&uid=swg21052226&loc=en\\_US&cs=utf-8&lang=en](http://www-01.ibm.com/support/docview.wss?rs=663&context=SSGSG7&uid=swg21052226&loc=en_US&cs=utf-8&lang=en)
- Tivoli Storage Manager Client Requirements on Microsoft Windows  
[http://www-01.ibm.com/support/docview.wss?rs=663&context=SSGSG7&uid=swg21197133&loc=en\\_US&cs=utf-8&lang=en](http://www-01.ibm.com/support/docview.wss?rs=663&context=SSGSG7&uid=swg21197133&loc=en_US&cs=utf-8&lang=en)

- Tivoli Storage Manager for Enterprise Resource Planning  
<http://www-01.ibm.com/software/tivoli/products/storage-mgr-erp/>
- Tivoli Storage Manager Supported Operating Systems  
[http://www-1.ibm.com/support/docview.wss?rs=663&context=SSGSG7&uid=swg21243309&loc=en\\_US&cs=utf-8&lang=en](http://www-1.ibm.com/support/docview.wss?rs=663&context=SSGSG7&uid=swg21243309&loc=en_US&cs=utf-8&lang=en)
- ▶ Microsoft Web pages:
  - Microsoft database clustering page  
<http://www.microsoft.com/windowsserver2003/enterprise/clustering.mspx>
  - Microsoft database mirroring page  
<http://www.microsoft.com/technet/prodtechnol/sql/2005/dbmirror.mspx>
  - Microsoft log shipping page  
<http://www.microsoft.com/technet/prodtechnol/sql/2000/reskit/part4/c1361.mspx?mfr=true>
- ▶ My SQL documentation  
<http://mysql2.mirrors-r-us.net/doc/maxdb/pdf/whitepaper.pdf>
- ▶ Oracle Web pages:
  - Oracle Dataguard page  
<http://www.oracle.com/technology/ deploy/availability/htdocs/DataGuardOverview.html>
  - Oracle database clustering page  
<http://www.oracle.com/technology/products/database/clustering/index.html>
  - Oracle Maximum Availability Architecture page  
<http://www.oracle.com/technology/ deploy/availability/htdocs/maa.htm>
- ▶ SAP Web pages:
  - BackInt interface manual  
<https://www.sdn.sap.com/irj/sdn/go/portal/prtroot/docs/library/uuid/24ae2e3a-0d01-0010-838f-ace2a9154bac>
  - BR\*Tools with Oracle manual  
<https://www.sdn.sap.com/irj/sdn/go/portal/prtroot/docs/library/uuid/a8910c3a-0d01-0010-a6a9-f4a8aae140fe>

- Oracle restore and recovery manual  
<https://www.sdn.sap.com/irj/sdn/go/portal/prtroot/docs/library/uuid/97a4f439-0d01-0010-d488-d29b45e2f5ab>
- SAP and SOA  
<http://www12.sap.com/platform/soa/index.epx>
- SAP BackInt manual  
[http://www.sapdb.org/pdf/backint\\_eng.pdf](http://www.sapdb.org/pdf/backint_eng.pdf)
- SAP business service  
[http://help.sap.com/saphelp\\_nw04/helpdata/en/2c/ed8e3f55b20617e1000000a114084/frameset.htm](http://help.sap.com/saphelp_nw04/helpdata/en/2c/ed8e3f55b20617e1000000a114084/frameset.htm)
- SAP database administration for Oracle manual  
<https://www.sdn.sap.com/irj/sdn/go/portal/prtroot/docs/library/uuid/20e638fc-a706-2a10-9d82-c40503247d30>
- SAP database for system copying  
<http://www.sapdb.org/7.4/htmhelp/21/692225b246b24f9202cb4433b5d691/content.htm>
- SAP High availability page  
<https://www.sdn.sap.com/irj/sdn/ha>
- SAP High availability page (protected)  
<http://service.sap.com/ha>
- SAP NetWeaver key capability  
[http://help.sap.com/saphelp\\_erp60\\_sp/helpdata/en/6a/44b2420e71c511e10000000a1550b0/frameset.htm](http://help.sap.com/saphelp_erp60_sp/helpdata/en/6a/44b2420e71c511e10000000a1550b0/frameset.htm)
- SAP product availability matrix (protected)  
<http://service.sap.com/pam>
- SAP solution page  
<http://www.sap.com/solutions/index.epx>
- ▶ Tivoli Storage Manager Information Center  
<http://publib.boulder.ibm.com/infocenter/tivihelp/v1r1/index.jsp>

## How to get Redbooks

You can search for, view, or download Redbooks, Redpapers, Technotes, draft publications and Additional materials, as well as order hardcopy Redbooks, at this Web site:

[ibm.com/redbooks](http://ibm.com/redbooks)

## Help from IBM

IBM Support and downloads

[ibm.com/support](http://ibm.com/support)

IBM Global Services

[ibm.com/services](http://ibm.com/services)

# Index

## Numerics

5.5.0.0-TIV-TSMERPDB2-AIX64.bin 245

## A

ABAP 16  
ABAP central services, see ASCS  
ABAP technology 19  
ACS 113  
addressserver command 335  
ADINT/TSM 106  
179  
Advanced Business Application Programming, see ABAP  
Advanced Copy Services, see ACS  
ALLOCATE command 151  
alter statement 102  
alter tablespace statement 191  
API 129  
application platform 18  
application program interface, see API  
ARCHDELETE 224  
archive command 327  
ASCS 27  
ASM 191  
Automatic Storage Management , see ASM

## B

BACKDELETE 224  
Background 25  
backint command 359  
backom command 86, 169, 250, 256, 260, 262, 323, 332  
BACKUP ARCHIVELOG command 148  
BACKUP command 62  
backup command 236  
backup considerations 61  
backup cycle 65  
backup ID, see BID  
backup modes 61  
backup policy 66  
backup requirement 55  
backup scheduling 82

backup types 61, 63  
backup\_dev\_type 284  
backup\_type 284  
backup/archive client 95  
BBP 78  
begin backup command 96  
BIA 42  
BID 141  
bootinfo command 218  
BR\*Tools 133  
br12 transaction 97  
BRARCHIVE command 99, 104, 133, 136, 254  
BRBACKUP 269  
BRBACKUP command 99, 133–134  
BRGUI command 134  
BRRECOVER command 133, 139  
BRRESTORE command 99, 104, 133, 139  
BRTTOOLS command 135  
business impact analysis, see BIA  
Business services 22  
business solutions 13  
Business Warehouse, see BW  
Business-to-Business Procurement, see BBP  
BW 78

## C

CAF 16  
Call Level Interface, see CLI  
CCMS 35, 83  
CCMS transaction 97  
central instance 26  
central services 27  
cfgmgr command 295, 321  
Change and Transport System, see CTS  
CHANNEL 151  
chmod command 226, 249  
CIM agent 335  
CLI 37, 157  
CLP 104, 260, 380  
COBIT 42  
COLD 121  
cold backup 61  
command 332

command-line interface, see CLI  
 Command-Line Processor, see CLP  
 commands  
     332  
     addressserver 335  
     ALLOCATE 151  
     archive 327  
     backint 359  
     backom 86, 169, 250, 256, 260, 262, 323, 332  
     BACKUP 62  
     backup 236  
     BACKUP ARCHIVELOG 148  
     begin backup 96  
     bootinfo 218  
     BRARCHIVE 99, 104, 133, 136, 254  
     BRBACKUP 99, 133–134  
     BRGUI 134  
     BRRECOVER 133, 139  
     BRRESTORE 99, 104, 133, 139  
     BRTOOLS 135  
     cfgmgr 295, 321  
     chmod 226, 249  
     CONFIGURE 152  
     cpio 139  
     crontab 86  
     DB2 104, 158  
     db2 85, 234, 236, 260, 376  
     db2\_all 257  
     DB2ADUTL 165, 220  
     db2adutl 240  
     db2clonedb 371  
     db2inidb 356  
     db2set 252  
     DBMCLI 174  
     dbmcli 106  
     dbmgui 106  
     dd 139  
     DELETE 153  
     DSMAPIPW 226  
     dsmapipw 229, 312  
     dsmc 86, 96, 191, 233, 286  
     dsmsta 304  
     echo 264  
     grep 263  
     installp 294  
     LIST 152  
     list 163  
     list history 380, 382  
     LOAD 104  
     lspp 295  
     mkysyb 51  
     nohup 307  
     oraenv 386  
     PRUNE 164  
     ps 385  
     query 238  
     query mgmtclass 60  
     recover 150–151  
     REGISTER NODE 224  
     REPORT 153  
     RESTORE 104, 236  
     restore 149, 237  
     resyncflash 321  
     rmdev 294  
     rollforward 236  
     rpm 333  
     rsh 336  
     SAPDBA 99  
     setupDB2BS 338, 343  
     show 390  
     smit 295  
     splitint 325, 341  
     sqlplus 386  
     startsap 311  
     stopsap 311  
     tdphdwb2 324, 341  
     tdphdwora 324  
     UPDATE 164  
     verifyconfig 335  
     webdbm 106  
     withdraw 357  
     CommonStore for SAP  
         archiving client 123  
         clients 122  
         CommonStore for SAP  
             overview 116  
         server prerequisites 121  
         utility client 125  
         viewing client 124  
     complete backup 63  
     Completed 86  
     Composite Application Framework, see CAF  
     computer output on laser disc, see COLD  
     Computing Center Management System, see CCMS  
     CONFIGURE command 152  
     consistent backup 61  
     Control Objectives for Information Technology, see

COBIT  
copy services 109  
COPYSERVICES\_SERVERPORT 340, 364  
COPYSERVICES\_USERNAME 340  
cpio command 139  
crontab command 86  
CTS 30

## D

data archiving 119  
data availability 44  
data management 4  
data protection 42, 68  
    file systems 51  
    operating system 51  
    SAP database 53  
data retention 68  
database  
    backup requirement 55  
database administration, see DBA  
database backup 61  
database backup tools 128  
database instance 27  
database recovery tools 128  
database shared library, see DBSL  
database storage 54  
db13 transaction 83  
DB2 command 104, 158  
db2 command 85, 234, 236, 260, 376  
DB2 Control Center 157  
DB2 Data Propagator 202  
DB2 Geoplex 202  
DB2 Tracker 202  
db2\_all command 257  
DB2\_VENDOR\_LIB 169  
DB2ADUTL 165  
DB2ADUTL command 165, 220  
db2adutl command 240  
db2clonedb command 371  
db2inidb command 356  
db2set command 252  
DBA 35  
DBMCLI command 174  
dbmcli command 106  
dbmgui command 106  
DBSL 37  
dd command 139  
DELETE command 153

Dialog 25  
dialog instance 27  
disaster recovery 81  
distributed relational database architecture, see DRDA  
DRDA  
DLL 118  
DMS 120  
document archiving 120  
Document Management System, see DMS  
document structure 5  
DOMAIN 224  
DRDA 38  
DS6000 108, 194  
DS8000 108, 194  
DSIERROR.LOG 263  
dsm.sys 276  
DSMAPIPW command 226  
dsmapipw command 229, 312  
dsmc command 86, 96, 191, 233, 286  
DSMI\_CONFIG 165, 168, 226  
DSMI\_DIR 165, 226  
DSMI\_LOG 165, 168, 226  
dsmsta command 304  
Duet 12  
Dynamic Link Library, see DLL

## E

EBP 77  
ECC 10  
echo command 264  
Enqueue 25  
Enterprise Buyer Professional, see EBP  
Enterprise Resource Planning, see ERP  
enterprise solutions 11  
Enterprise Storage Server, see ESS  
Enterprise Storage System, see ESS  
ERP 4, 8, 11, 97  
ERP Central Component, see ECC  
ESS 108–109  
ESS 800 194  
ESS Metro-Mirror 194

## F

FAILARCHPATH 169  
Failed 86  
failure types 47  
full backup 63

## G

Governance Risk, and Compliance, see GRC  
graphical user interface, see GUI  
GRC 13  
grep command 263  
GUI 36, 106

## H

HA 49, 76  
HACMP/XD 192  
HADR 199  
High Availability Disaster Recovery, see HADR  
high availability, see HA  
hot backup 63  
HP-UX Service Guard 193  
HTTP 116  
Hypertext Transfer Protocol, see HTTP

## I

IGS 26  
IIC 122  
include exclude options 59  
incremental backup 63  
independent software vendor, see ISV  
Information Integrator for Content, see IIC  
install command 294  
Internet Graphics Service, see IGS  
Internet Transaction Server, see ITS  
ISV 293  
IT Infrastructure Library, see ITIL  
ITIL 42  
ITS 77–78  
ITSM architecture 92

## J

J2EE 20  
JAAS 20  
Java 2 Enterprise Edition, see J2EE  
Java Authentication and Authorization Service, see JAAS  
Java central services, see SCS  
Java Runtime Environment, see JRE  
Java technology 20  
JFS 113  
Journaled File System, see JFS  
JRE 122

## L

LAN 90, 292  
LAN-free backup 97  
LANFREECOMMMETHOD 297  
Linear Tape Open, see LTO  
LIST command 152  
list command 163  
list history command 380, 382  
LOAD command 104  
local area network, see LAN  
Log Shipping 201  
LOGARCHMETH1 169  
LOGARCHOPT1 169  
lspp command 295  
LTO 216, 271

## M

MAA 197  
MAX\_VERSIONS 181, 281  
MAX\_VERSIONS=0 181  
MaxDB 106  
Maximum Availability Architecture, see MAA  
MAXNUMMP 224  
MAXNUMP 143  
MAXVERSION 67  
Media Management System, see MMS  
Metro Mirror replication 194  
Mirroring 201  
Missed 86  
mksysb command 51  
MMS 177

## N

NetWeaver 14  
NetWeaver Development Infrastructure, see NWDI  
NODENAME 224  
nohup command 307  
NWDI 21

## O

Objects Linking and Embedding, see OLE  
ODBC 94  
offline backup 61  
OLE 124  
one-system landscape 34  
online backup 63  
operational 76



Oracle Application Server 197  
Oracle Dataguard 197  
Oracle Recovery Manager, see RMAN  
Oracle SID 276  
ORACLE\_HOME 386  
ORACLE\_SID 386  
oraenv command 386  
organization 5

## P

PAM 35  
partial backup 64  
PASSWORD 224  
PASSWORDACCESS 143, 248, 279  
Peer to Peer Remote Copy, see PPRC  
point 43  
POWER5 108  
PPRC 195  
PRIMARY\_COPYSERVICES\_SERVERNAME  
340, 364  
Product Availability Matrix, see PAM  
PROLE\_PORT 283  
PROMPT 279  
protection levels 44  
PRUNE command 164  
ps command 385

## Q

query command 238  
query mgmtclass command 60

## R

R/2 8  
RAC 197  
RDBMS 54  
Real Application Cluster, see RAC  
recover command 150–151  
Recovery Point Objective, see RPO  
Recovery Time Objective, see RTO  
Red Hat Cluster 193  
Redbooks Web site 408  
    Contact us xviii  
redo log files 63  
REGISTER NODE command 224  
relational database management systems, see RDBMS  
Remote Function Call, see RFC

REPORT command 153  
RESTORE command 104, 236  
restore command 149, 237  
resyncflash command 321  
Retention period 67  
RETVR 67, 221  
RFC 118  
RMAN 99, 145  
rman\_parms 284  
rmdev command 294  
roll-forward 94  
rollforward command 236  
rpm command 333  
RPO 44, 219, 273  
rsh command 336  
RTO 43–44

## S

SAML 20  
SAN 292, 296  
SAN Volume Controller, see SVC  
SAP 4, 107  
    application platform 18  
    architecture 23  
    business solutions 13  
    central instance 26  
    central services 27  
    change and transport system 30  
    change management 34  
    clients 31  
    configuration file 276  
    data protection 49  
    database 17, 35  
    database instance 27  
    dialog instance 27  
    enterprise solutions 11  
    key capabilities 14  
    NetWeaver overview 13  
    product history 8  
    products 11  
    R/2 8  
    scheduler 82  
    solutions 11  
    system landscape 32  
    system topologies 28  
    transaction  
        br12 97  
        CCMS 97

- db13 83
- SAP Business Suite 11
- SAP Business Warehouse, see SAP BW
- SAP BW 77
- SAP Manufacturing 12
- SAP MaxDB 172
- SAP NetWeaver 13
- SAP Service and Asset Management 12
- SAPDBA command 99
- SBT 130
- SC33-6341 262
- scheduling 82
- SCS 27
- SDA 26
- SDM 26
- Secure Backup to Tape, see SBT
- Secure Network Communications, see SNC
- Security Assertion Markup Language, see SAML
- SELECT statement 94
- select statement 197
- SEM 9
- service levels 44
- setupDB2BS command 338, 343
- show command 390
- smit command 295
- SNC 20
- SNIA 42
- Software Deployment Archives, see SDA
- Software Deployment Manager, see SDM
- Solaris Cluster 193
- splitint command 325, 341
- Spool 25
- SQL
  - SELECT 94
- SQL commands
  - alter 102
  - alter tablespace 191
  - SELECT 94
  - select 197
- sqlplus command 386
- startsap command 311
- stopsap command 311
- storage agent 97
- storage area network, see SAN
- Storage Networking Industry Association, see SNIA
- storage repository 94
- Strategic Enterprise Management, see SEM
- SVC 334
- SVC Metro Mirror 194

- SYSADM 158
- SYSCTRL 158
- SYSMAINT 158

## T

- Tablespace Definition Information, see TDI
- tape release 67
- TARGET\_VOLUME 341
- TCO 4
- TDI 167, 259
- TDP\_DIR 169
- tdphdwdw2 command 324, 341
- tdphdwora command 324
- three-tier system landscape 32
- Tivoli Storage Manager 90
  - Advanced Copy Services 107
  - architecture 92
  - backup 96
  - backup/archive client 95
  - databases 105
  - Enterprise Resource Planning 97
  - overview 90
  - scheduling 85
  - server 94
  - storage agent 97
- Tivoli Storage Manager, see TSM
- Tivoli System Automation 192
- TNS\_ADMIN 386
- total cost of ownership, see TCO
- TSM 113
- TSM\_MGMTCLASS 231
- TSM\_NODENAME 231
- TSM\_OWNER 231
- TSM\_PASSWORD 231
- TSM1\_FS 286
- two-system landscape 34

## U

- uninterruptible power supply, see UPS
- Universal Resource Locator, see URL
- Universal Unique Identifier, see UUID
- Update 25
- UPDATE command 164
- UPS 77
- URL 116
- util\_par\_file 284
- UUID 117

**V**

VDI 130  
verifyconfig command 335  
Veritas Cluster Server 193  
Virtual Device Interface, see VDI

**W**

webdbm command 106  
withdraw command 357  
workload scheduling tools 87

**X**

X/Open Backup Services APIs, see XBSA  
XBSA 163  
XINT\_PROFILE 169, 283

Archived

Archived



## SAP Backup using Tivoli Storage Manager

(0.5" spine)  
0.475" <-> 0.875"  
250 <-> 459 pages







# SAP Backup using Tivoli Storage Manager

**Covers and compares data management techniques for SAP**

**Presents a sample implementation of DB2 and Oracle databases**

**Explains LAN-free and FlashCopy techniques**

In this IBM Redbooks publication, we give an overview of different data management topics related to a typical SAP data center. The intrinsic functionality of SAP is not designed to completely handle all the tasks of a data center by itself, but the SAP system offers several interface possibilities to attach external tools to it to accomplish this task.

We explain SAP basic concepts and the issues with SAP data management. We introduce Tivoli Storage Manager and all of its products that are related to SAP data management. We provide some comparison between database backup and recovery tools. Finally, we discuss data archiving using IBM DB2 CommonStore for SAP, and discuss high availability requirements and disaster recovery considerations.

The second part of this book discusses a practical implementation of SAP backup and recovery with Tivoli Storage Manager. We implement this setup on two separate SAP systems: one running DB2 and the other running Oracle database. We also implement LAN-free backup and FlashCopy scenarios.

In the sample implementation section, we show many different tasks, such as backup and restore, database recovery, backup monitoring, and tuning. We also cover some advanced backup/availability considerations, such as split mirror backup and standby databases.

This book helps individuals that operate an SAP environment to devise a strategy for a sound and comprehensive data backup solution using the IBM Tivoli Storage Management product family.

**INTERNATIONAL  
TECHNICAL  
SUPPORT  
ORGANIZATION**

**BUILDING TECHNICAL  
INFORMATION BASED ON  
PRACTICAL EXPERIENCE**

IBM Redbooks are developed by the IBM International Technical Support Organization. Experts from IBM, Customers and Partners from around the world create timely technical information based on realistic scenarios. Specific recommendations are provided to help you implement IT solutions more effectively in your environment.

**For more information:  
[ibm.com/redbooks](http://ibm.com/redbooks)**