

TestLine Modular Components

Durable and reconfigurable

MTS OFFERS A VARIETY OF **MODULAR TESTING PRODUCTS** TO QUICKLY CONFIGURE MECHANICAL TESTS ON YOUR PARTS OR ASSEMBLIES. THESE PRODUCTS ARE DESIGNED SPECIFICALLY TO WITHSTAND DEMANDING APPLICATIONS SUCH AS LONG-TERM DURABILITY TESTS AND CAN BE USED WITH NEW OR YOUR EXISTING MTS ACTUATORS.

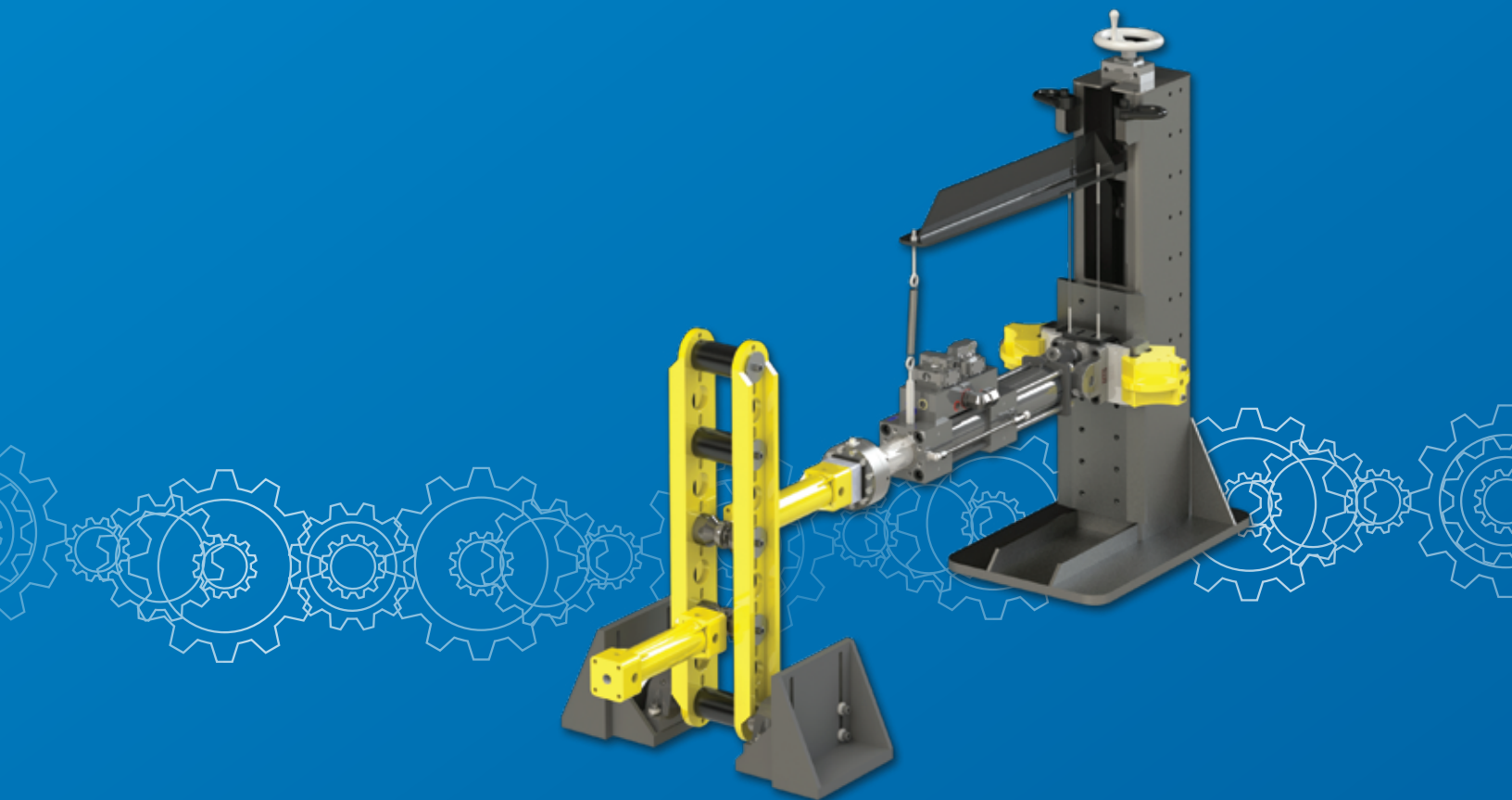

TestLine™ Modular Components

MTS offers a variety of modular testing products to quickly configure mechanical tests on your parts or assemblies. These products are designed specifically to withstand demanding applications such as long-term durability tests and can be used with new or your existing MTS actuators.

BENEFITS

- » Proven designs used by over 1,200 companies in 51 countries
- » Engineered to maximize your long-term investment
- » Versatile components that can be adapted to meet your testing needs
- » Modular designs provide flexibility and easy assembly of reconfigurable test stands.
- » All Testline components are serviced and supported by globally, recognized engineering experts.

FEATURES

- » Engineered by MTS for durable, fatigue rated applications
- » Stiff, light weight construction for higher performance testing
- » Multiple connecting points on levers and bell cranks allow for various mechanical ratios to increase the force or displacement of your existing actuators

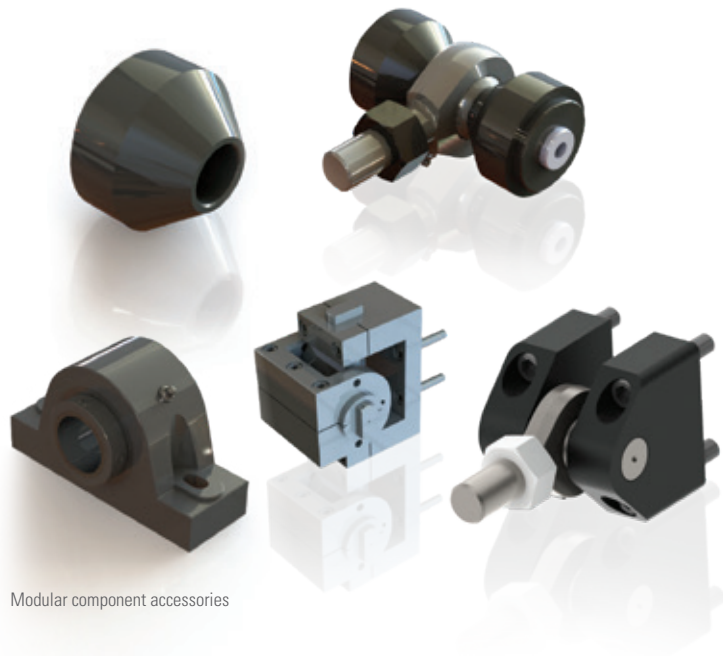

Modular component accessories

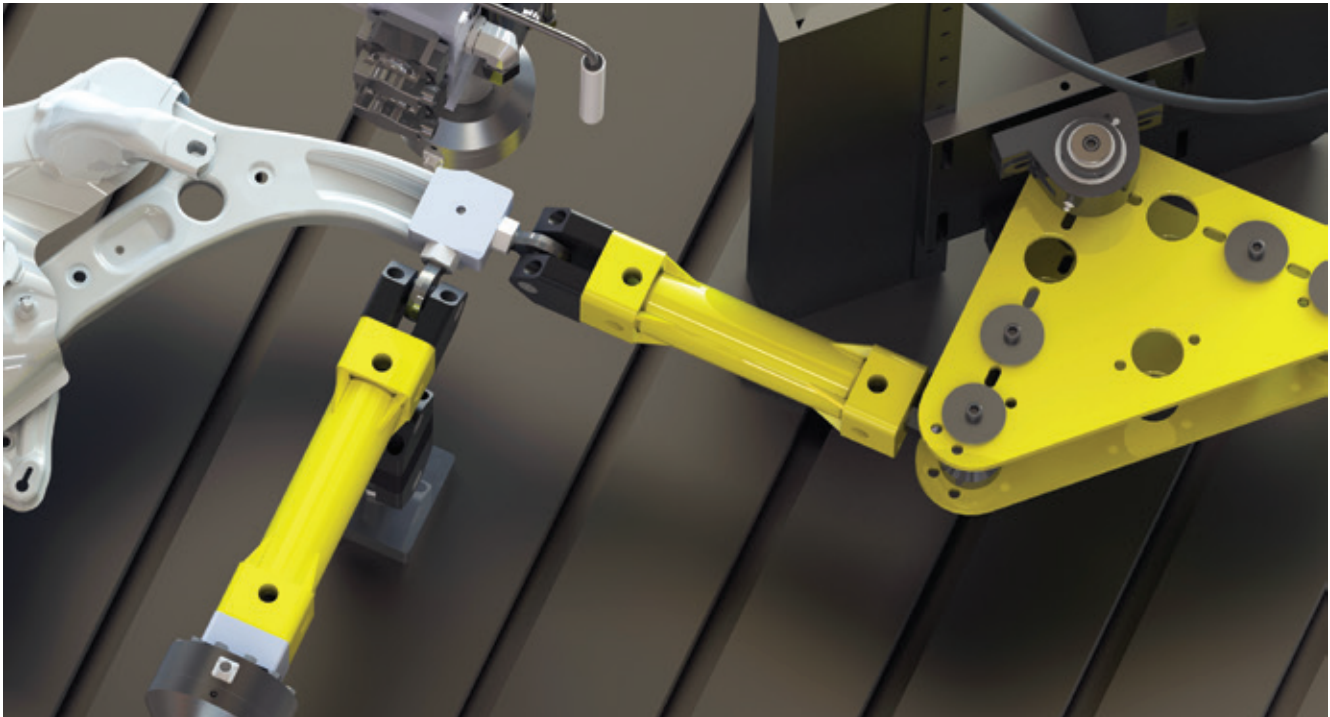

A combination of struts and levers used to apply a biaxial load to a control arm

TestLine™ Bell Cranks

Bell cranks are used to gain a mechanical advantage, react horizontal forces into a bed plate or floor, and isolate an actuator from moments and side loads. The bell crank assembly comes complete with two swivel rod ends and two pillow block bearings with 25 mm (1 inch) spacers for mounting. The optional mounting plate (100-056-342) shown is used to attach the bell crank to the reaction stand (100-001-944).

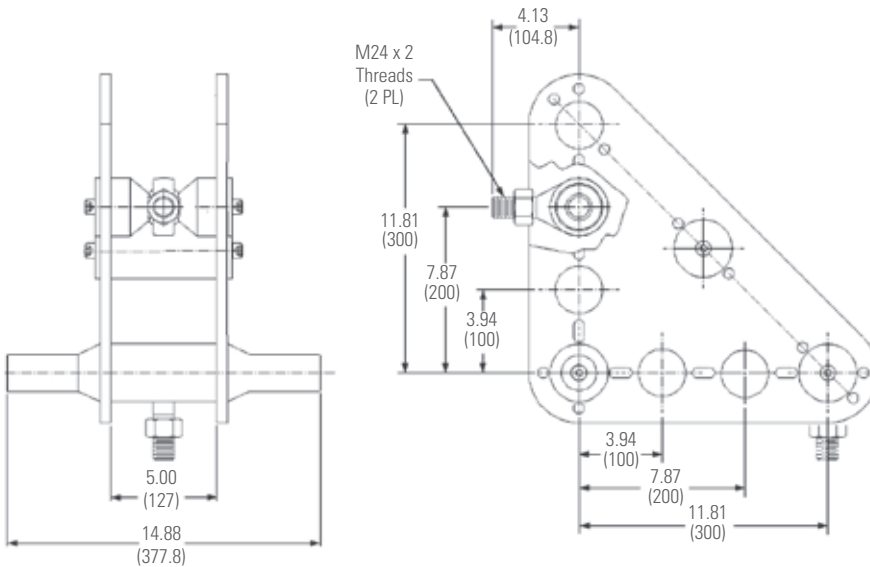

BENEFITS

- » Proven modular designs
- » Engineered for the demands of high performance testing
- » Equipped with swivel rod ends

Bellcrank Assembly

Description	* Max. Force	Weight	Part Number
Bell Crank Assembly. Includes (2) pillow block bearings (100-001-207) and 25mm spacers (100-010-229)	50 kN (11,000 lbs)	36 kg (80 lbs)	100-056-345

* When a bell crank is used to gain a mechanical advantage the increased force achieved should not exceed the maximum load rating specified.

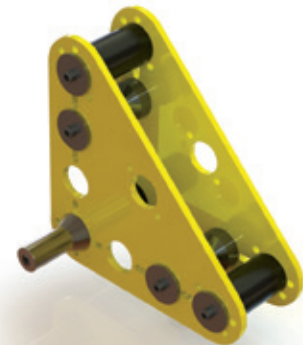

TestLine™ Levers

The lever assembly is typically used to obtain a mechanical advantage in either force or displacement and isolate actuators from moments and side loads. The assembly includes two swivel rod ends and two bearings. The lever can be mounted to a bed plate with the optional floor-mounted lever bracket (100-056-341) or to a reaction stand (100-001-944) using the optional bell crank/lever mounting plate (100-056-342) and vertical brackets (100-056-343).

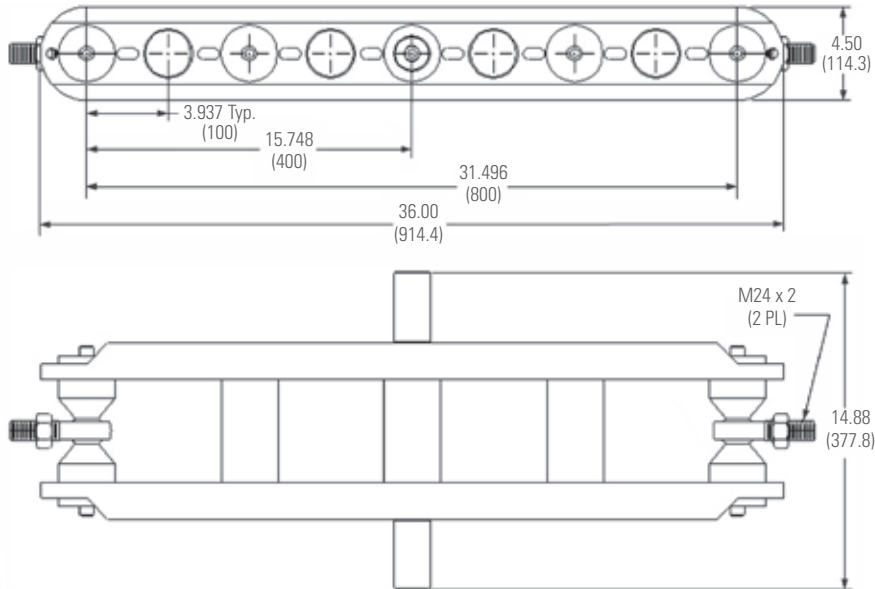

BENEFITS

- » Proven modular designs
- » Engineered for the demands of high performance testing
- » Includes pillow block bearings



Levers Assembly

Description	* Max. Force	Weight	Part Number
Lever Assembly. Includes two pillow block bearings (100-001-207)	50 kN (11,000 lbs)	41 kg (90 lbs)	100-056-344

* When a lever is used to gain a mechanical advantage the increased force achieved should not exceed the maximum load rating specified.



Lever assembly (100-056-344).

TestLine™ Bell Crank and Lever Accessories

BENEFITS

- » Proven modular designs
- » Engineered for the demands of high performance testing
- » Versatile components that can be adapted to meet your testing needs

Pillow Block Bearing (100-001-207)

The TestLine Pillow Block Bearings are precision, self-aligning bearings for mounting bell cranks and levers to a reaction base or stand.

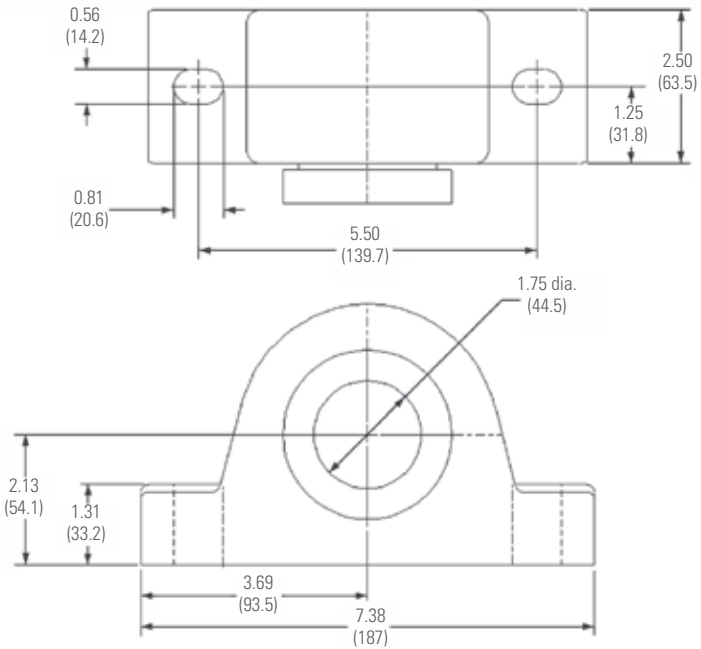

Universal Joint (100-001-298)

TestLine Universal Joints are used with bell cranks and levers to provide a connection that will rotate about two axes. The four hole pattern in the U-joint mates directly with the universal struts. Other components can be attached using one of the optional swivel adapters and a threaded stud.

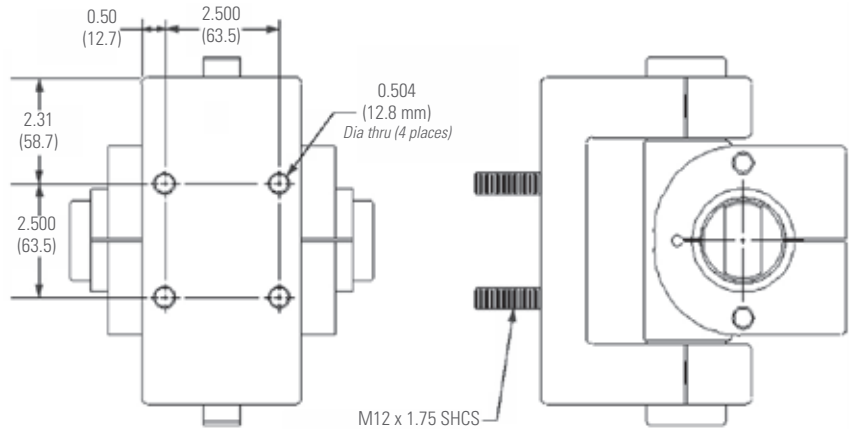

Rod End and Solid Spacers

(Rod End Spacer:100-056-338)

(Solid Spacer:100-056-337)

The TestLine Rod End and Solid Spacers are used in the bell crank and lever assemblies. The swivel spacer provides a pivoting and rotating connection to actuators, struts, or other components.

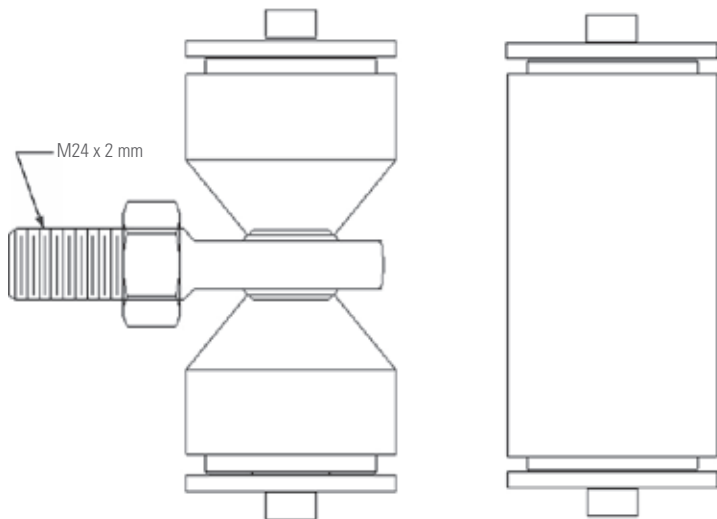

TestLine™ Lever/Bell Crank Mounting Bracket

This bracket is used to mount both the TestLine Lever and Bell Crank assemblies to a bed plate. The height of the pivot point is adjusted by raising or lowering the mounting bracket. The bracket does not include the bearings.

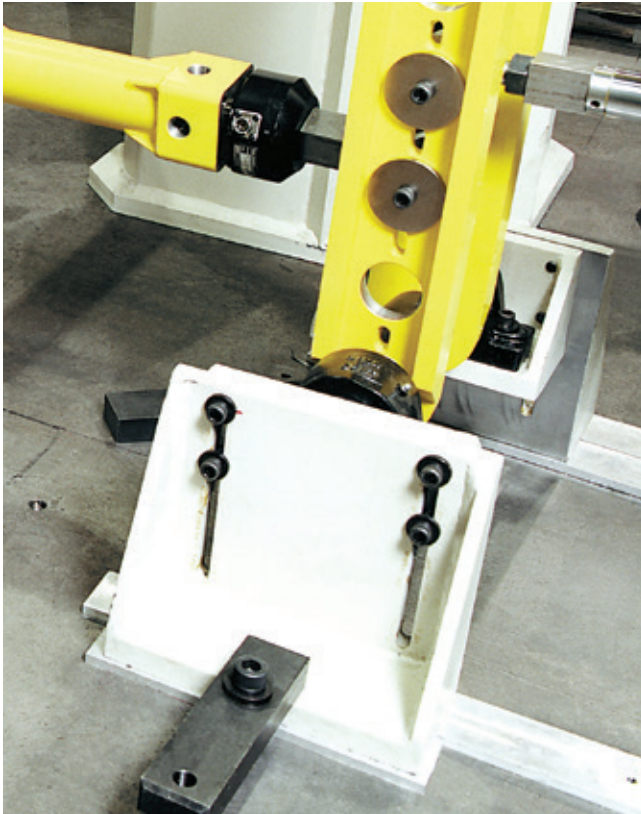

Mounting bracket for levers and bell cranks

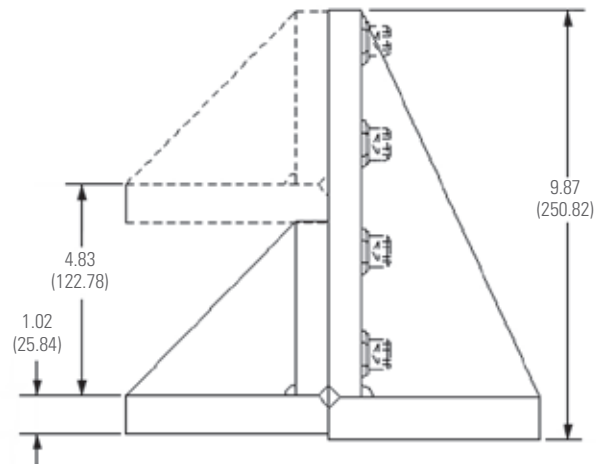
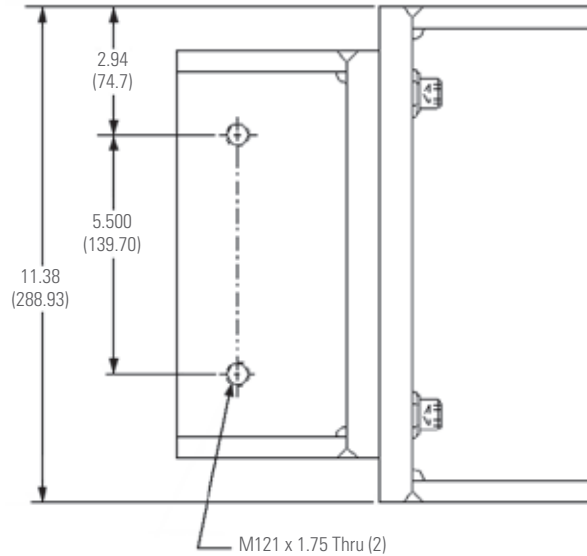

BENEFITS

- » Proven modular designs
- » Used for both Lever and Bell Crank assemblies
- » Engineered for the demands of high performance testing

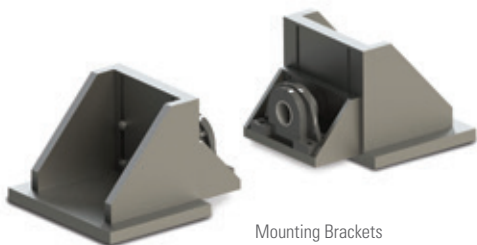

Mounting Brackets

Lever/Bell Crank Assembly

Description	Max. Force Rating	Weight	Part Number
Lever/Bell Crank Mount (set of two)	50 kN (11,000 lbs)	38.4 kg (84 lbs)	100-056-341

TestLine™ Reaction Stand

The reaction stand is used to support bell cranks as well as other parts or assemblies. A series of holes in the stand along with slotted holes in the optional mounting plates and brackets provide for infinite height adjustment of the bell crank.

- BENEFITS**
- » Proven modular designs
 - » Engineered for the demands of high performance testing
 - » Adds flexibility to your test setup options



Reaction stands shown with a bell crank

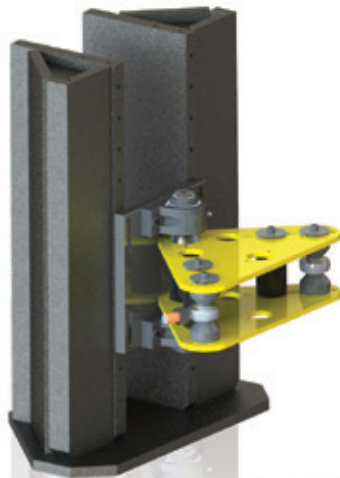
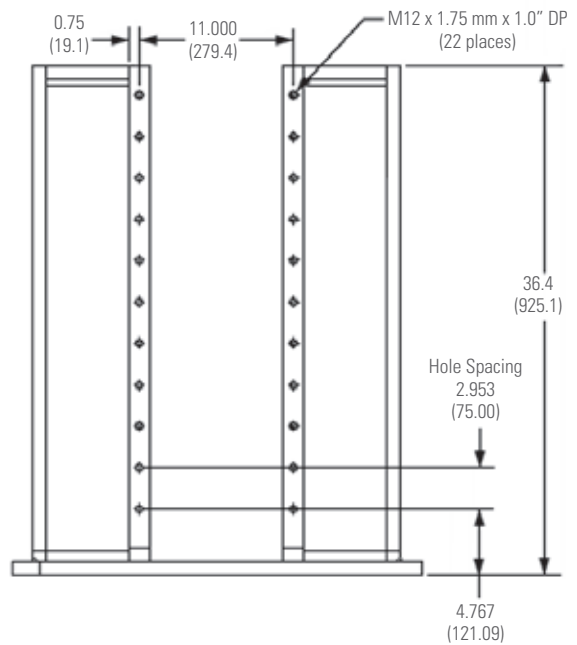
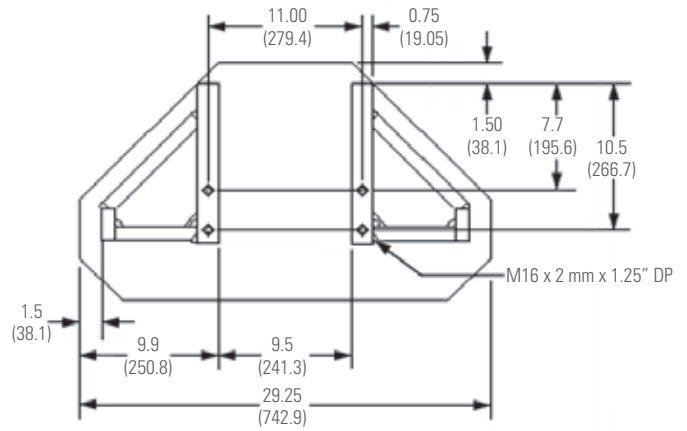

Reaction Stand Assembly

Description	Max. Force Rating	Weight	Part Number
Reaction Stand	50 kN (11,000 lbs)	382 kg (840 lbs)	100-001-944

TestLine™ Reaction Stand Accessories

Bell Crank and Lever Horizontal Mounting Plate (100-056-342)

The TestLine Bell Crank and Lever Horizontal Mounting Plate is used to mount a bell crank or lever to a reaction stand (100-001-944) in a horizontal orientation. Weight: 22.5 kgs (49 lbs.).

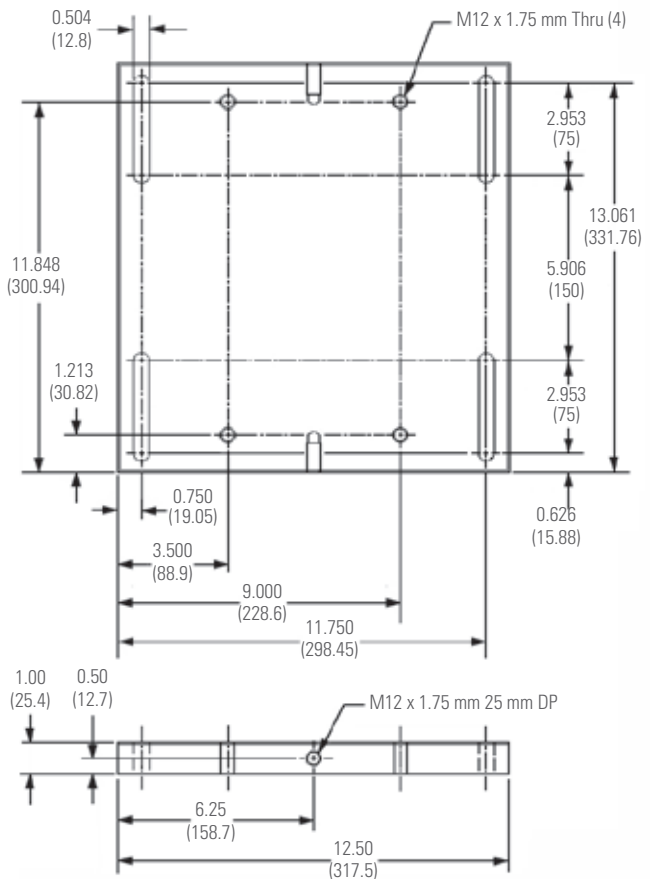

Bell Crank and Lever Horizontal Mounting Plate

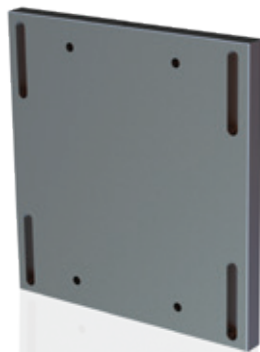

Bell Crank Mounting Plate



Mounting Bracket

Bell Crank and Lever Vertical Mounting Bracket (100-056-343)

The TestLine Mounting Brackets are used to mount bell cranks or levers to a reaction stand (100-001-944) in a vertical orientation. The kit includes two brackets. Weight: 5.2 kgs (11.5 lbs.).

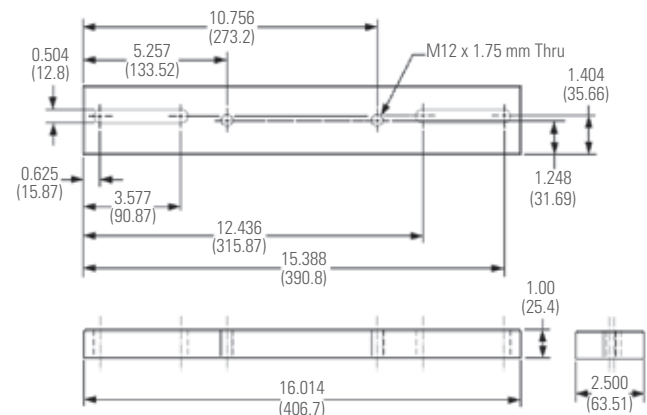

Bell Crank and Lever Vertical Mounting Bracket

BENEFITS

- » Both vertical and horizontal mounting plates available
- » Engineered for the demands of high performance testing
- » Adds flexibility to your test setup options

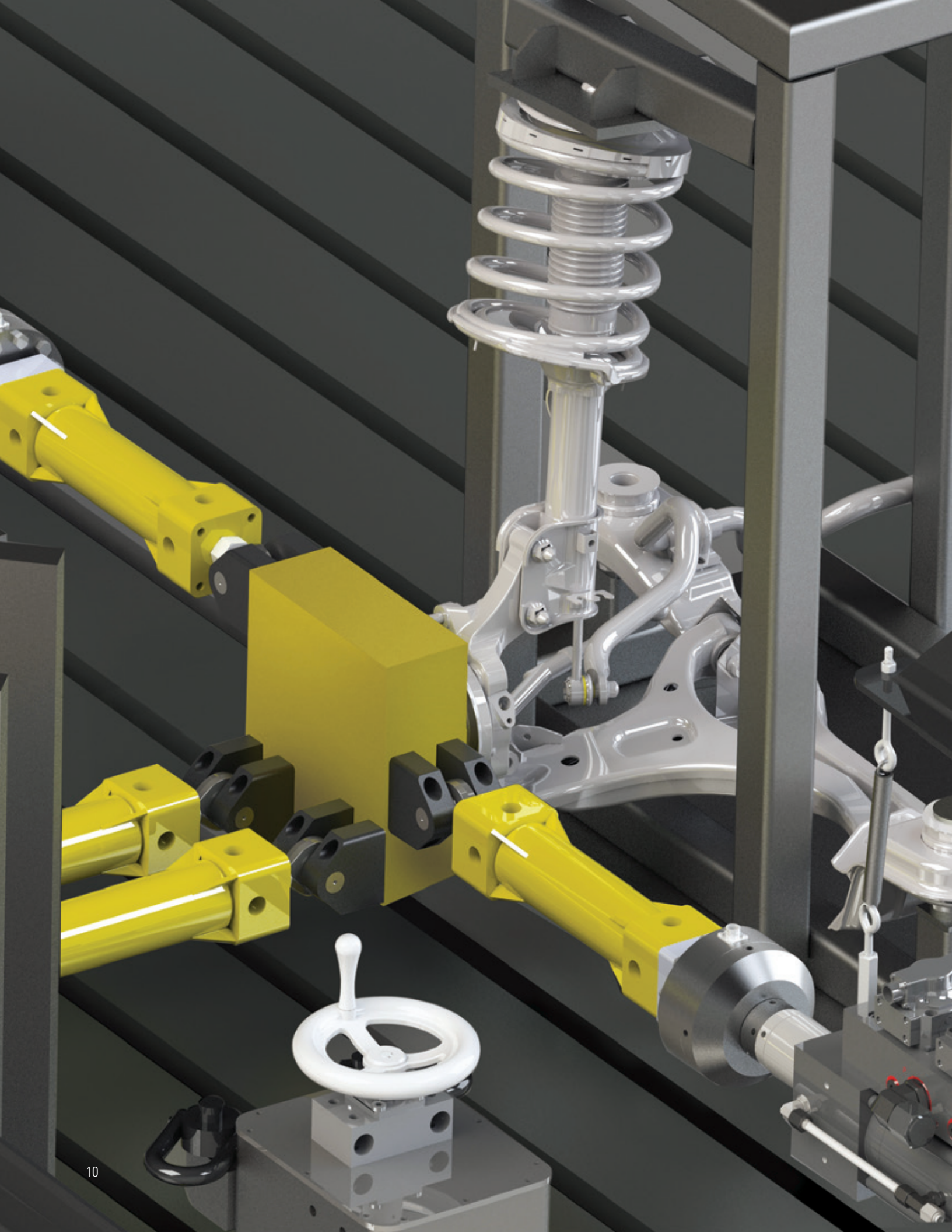

TestLine™ Universal Struts

These universal struts are primarily used to transfer loads in the axial direction of the strut. However, the universal ends allow other actuators or struts to be connected perpendicular to the axis of the strut for biaxial loads or motion. The biaxial loads should be applied at the end attached to the test specimen to avoid side loading actuators and other modular components. A number of options such as rod ends, swivels, and threaded adapters are available to attach the struts to other components.

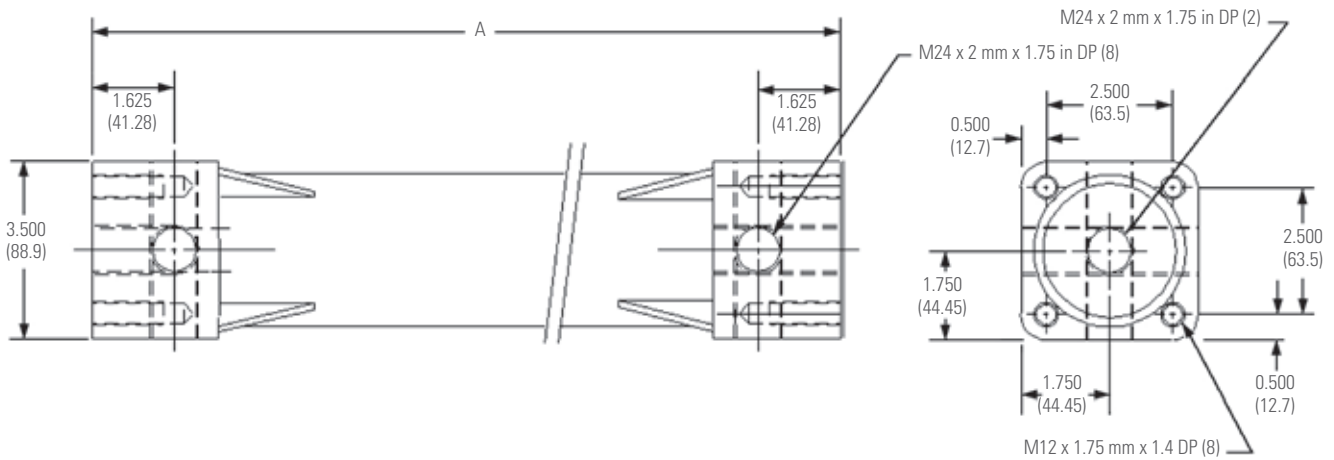

Description	Length (A)	* Max. Force	Weight	Part Number
Universal Strut - 375	375 mm (14.76 in)	50 kN (11,000 lbs)	10.9 Kg (24 lbs)	055-204-402
Universal Strut - 875	875 mm (34.45 in)	50 kN (11,000 lbs)	15 Kg (33 lbs)	055-204-502
Universal Strut - 1675	1675 mm (66 in)	50 kN (11,000 lbs)	22 Kg (48 lbs)	055-204-602



BENEFITS

- » Proven modular designs
- » Engineered for the demands of high performance testing
- » Many attachment options are available

TestLine™ Universal Strut Accessories

Rod End Swivel (100-056-336)

TestLine modular swivels will bolt on the end of the universal struts for connections that should be allowed to pivot or rotate. Optional swivel adapters are available for attaching the clevis end of the swivel with a threaded stud.

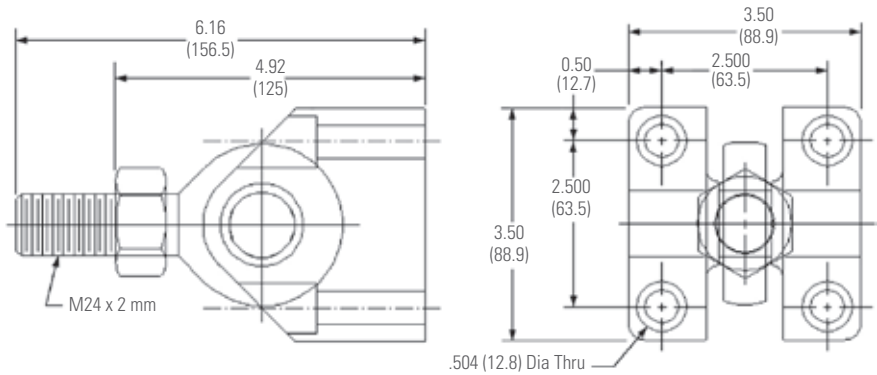

Rod End (100-056-339)

This is a heavy-duty Rod End with integrated spherical bearing.

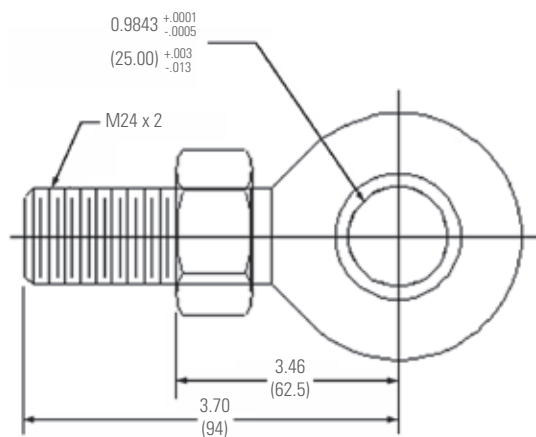

Load Cell/Actuator Adapter

The TestLine Load Cell/Actuator Adapters are used to connect rod ends on bell cranks and levers to load cells and actuators. A threaded stud is included with the adapter.

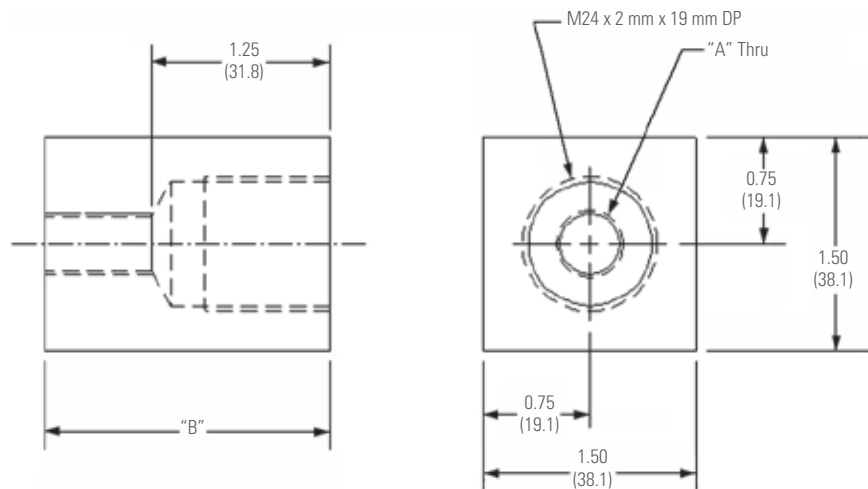

BENEFITS

- » Add flexibility to your test system
- » Engineered for the demands of high performance testing
- » Proven modular designs

Part Number	Length (B)	Thread (A)	Threaded Stud
SA-049-001	51 mm (2.0 in)	M12 x 1.25 mm	M12 x 1.25 mm x 55 mm Long
SA-049-002	64 mm (2.5 in)	M27 x 2 mm	M27 x 2 mm x 60 mm Long
SA-049-011	51 mm (2.0 in)	1/2 - 20 in	1/2 - 20 in x 2.25 in Long
SA-049-012	64 mm (2.5 in)	1 - 14 in	1 - 14 in x 2.5 in Long

Swivel Adapters

Swivel adapters are available to connect the rod end swivel (100-056-336) to components using a threaded stud (included).

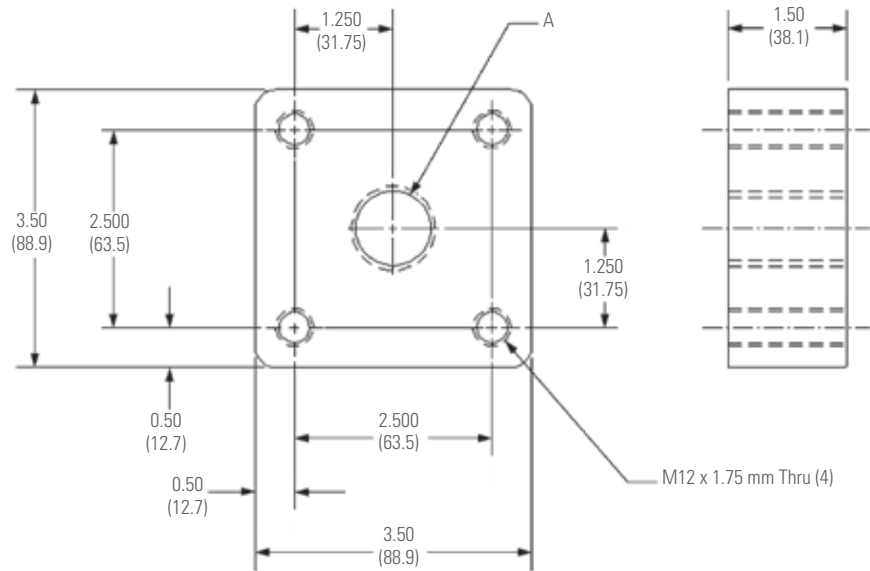

Part Number	Weight	Thread (A)	Threaded Stud
SA-050-001	2.6 kg (5.7 lbs)	M12 x 1.25 mm	M12 x 1.25 mm x 57 mm long
SA-050-002	2.8 kg (6.2 lbs)	M27 x 2 mm	M27 x 2 mm x 64 mm long
SA-050-011	2.6 kg (5.7 lbs)	1/2 - 20 in	1/2 in - 20 x 2.25 in long
SA-050-012	2.8 kg (6.2 lbs)	1 - 14 in	1 in - 14 x 2.5 in long

Strut Adapters

Strut adapters bolt directly to the end of the universal struts to allow the strut to be connected to other components such as load cells or actuators using a threaded stud (included).

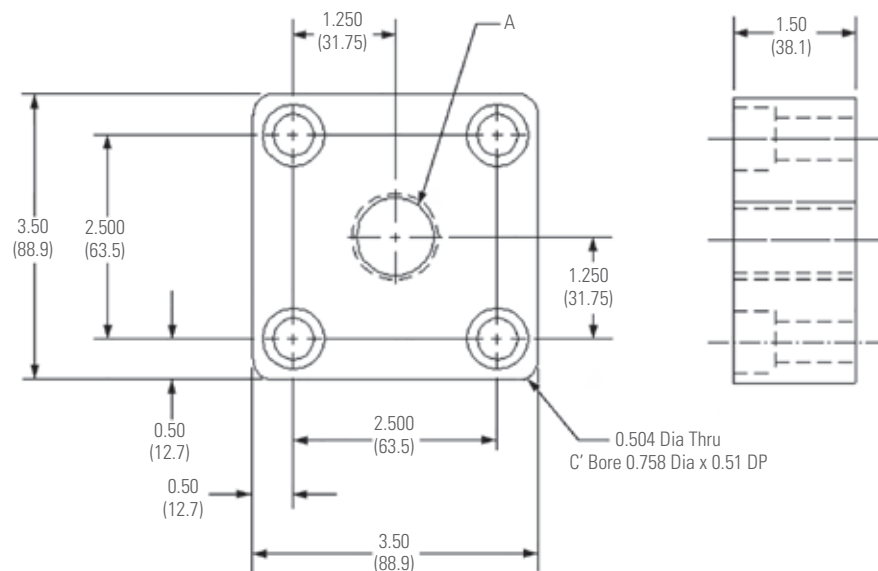

Part Number	Weight	Thread (A)	Threaded Stud
SA-051-001	2.6 kg (5.7 lbs)	M12 x 1.25 mm	M12 x 1.25 mm x 57 mm long
SA-051-002	2.8 kg (6.2 lbs)	M27 x 2 mm	M27 x 2 mm x 64 mm long
SA-051-011	2.6 kg (5.7 lbs)	1/2 - 20 in	1/2 - 20 in x 2.25 in long
SA-051-012	2.8 kg (6.2 lbs)	1 - 14 in	1 - 14 in x 2.5 in long

Build Your Own Bicycle Component Test System with Standard Products and TestLine Components from MTS

MTS provides a variety of test system products and components that let you mix and match to meet nearly all durability and fatigue tests on bicycle components. Components can include the frame, swing arm, fork, and many others. Called TestLine™ components, they are based on a philosophy of helping test laboratories meet their special needs by making their own test systems from proven servohydraulic test products. When you choose to construct your own component test systems you can use proven products to measure and validate the stiffness and durability of frame and suspension elements. TestLine tools can also help you perform vibration tests on components and validate finite element analysis models.

BENEFITS

- » Test components faster in the laboratory than on the road or trail
- » Test components without having to test a complete bicycle
- » Easy test reconfiguration because of modular design
- » Modular test systems are easily expanded to meet your future needs
- » Choose from a range of control capabilities, from simple sine wave inputs to time history simulation
- » Proven MTS quality, reliability, and durability

MTS COMPONENT TEST SYSTEMS CAN BE CONFIGURED FOR DURABILITY, STIFFNESS, AND VIBRATION TESTING OF THE FOLLOWING COMPONENT AND SUBASSEMBLY TESTS

- » Fork – Rigid/Suspension
- » Frame head tube
- » Frame
- » Rear suspension
- » Handlebar/Stem
- » And more

For component testing, you can choose from a wide selection of MTS standard products, which you can order and put together to build your own mechanical testing system. These include:

- » SilentFlo hydraulic power supplies, manifolds, and distribution systems
- » Actuators and servovalves
- » Electronic test controllers and software (including total test management, function generation, data acquisition, and simulation testing)
- » A variety of other accessories, including load frames, test tables, and more

The modular design of MTS test system components will make it easy for you to focus on producing a fully functional mechanical test system that will produce meaningful, accurate, and repeatable results, as quickly as possible. That means they are easily configured and reconfigured to meet your changing testing needs. MTS engineers or consultants will work with you to make sure the components you specify work together and are appropriate for the tests you describe.

Actuators

MTS actuators are engineered and tailored for the critical role they play in accurately and repeatably applying the forces to your test specimen. MTS provides both linear and rotary actuators, each engineered to minimize friction and stiction while maximizing reliability, wear resistance, and ease of maintenance. Every day thousands of engineers use MTS actuators in demanding vehicle dynamics, structural fatigue, and component test stand applications. Of course, MTS also provides the actuator accessories required for testing, such as load cells, swivel bases, swivel end rods, and spiral washers.

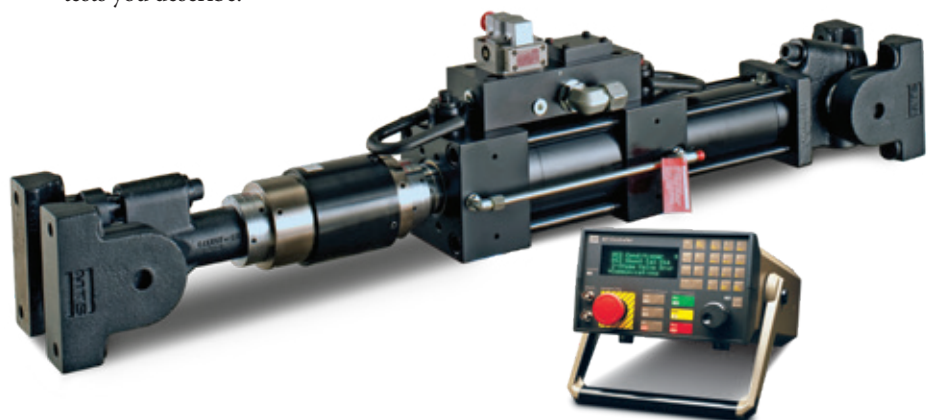

MTS SilentFlo Hydraulic Power Units

A wide range of power units engineered for the demands of mechanical testing are available from MTS, as well as hoses, manifolds, and servovalves. All MTS SilentFlo HPU components are designed to provide trouble free operation and long life while meeting the exacting demands of mechanical testing. They meet or exceed common international safety regulations and are supported by an international network of trained service personnel.



Test Control and Analysis Systems

You have a sweeping selection of alternatives from which to specify the system to control your test. By combining the servocontroller with fixturing you are ready to apply loads to your test specimen. You have the flexibility of applying a variety of loads ranging from simple single channel ramp and hold, to simple sine waves, to realtime simulation application of several channels of loads simultaneously.

Your choice begins with the basic Model 407 Controller, an inexpensive, modular, single channel, digitally supervised device. It provides a variety of simple waveforms. And it can be easily upgraded with automation options that expand your test capabilities. An automation alternative also allows several Model 407s, each running a test, to be networked under the supervision of a PC. Another automation option is to play out time histories from a PC fitted with Component RPC® (cRPC™) III software and hardware boards.

To meet more complex needs, MTS offers you a variety of FlexTest® controllers which provide more alternatives in testing, including the construction of custom test applications to meet your unique needs. A variety of software packages offers you a choice ranging from simple to complex, multichannel, multi-station component tests, including RPC (Remote Parameter Control™) realtime simulation.



For More Information

Your choice of actuators, power unit, and controller depends on your anticipated test application and your anticipation of future needs. Supported by MTS field sales engineers, technical staff, or MTS Simulation Test Consultants, MTS can work with you in selecting, matching, and designing test fixtures as well as component sizing, data collection, and data analysis. Contact MTS to arrange for a technical discussion.

Regional Business Centers

THE AMERICAS

MTS Systems Corporation
14000 Technology Drive
Eden Prairie, MN 55344-2290
USA
Telephone: 952-937-4000
Toll Free: 800-328-2255
E-mail: info@mts.com
Internet: www.mts.com

EUROPE

MTS Systems France
BAT EXA 16
16/18 rue Eugène Dupuis
94046 Créteil Cedex
France
Telephone: +33-(0)1-58 43 90 00
E-mail: contact.france@mts.com

MTS Systems (Germany) GmbH
Hohentwielsteig 3
14163 Berlin
Germany
Telephone: +49-(0)30 81002-0
E-mail: euroinfo@mts.com

MTS Systems S.R.L. a socio unico
Strada Pianezza 289
10151 Torino
Italy
Telephone: +39-(0)11 45175 11 sel. pass.
E-mail: mtstorino@mts.com

MTS Systems Norden AB
Datavägen 37b
SE-436 32 Askim
Sweden
Telephone: +46-(0)31-68 69 99
E-mail: norden@mts.com

MTS Systems Limited
98 Church Street,
Hunslet,
Leeds
LS102AZ
United Kingdom
Telephone: +44 (0) 113 270 8011
E-mail: mtsuksales@mts.com

ASIA/PACIFIC

MTS Japan Ltd.
Raizen Bldg. 3F 3-22-6,
Ryogoku, Sumida-ku,
Tokyo 130- 0026
Japan
Telephone: +81 3 5638 0850
E-mail: mts-j-info@mts.com

MTS Korea, Inc.
2nd F, Bundang Yemiji Building, 31,
Hwangsa-eul-ro 258beon-gil,
Bundang-gu, Seongnam-si,
Gyeonggi-do, 13595
Korea
Telephone: +82-31-728-1600
E-mail: mtsk-info@mts.com

MTS Systems (China) Co., Ltd.
Floor 34, Building B,
New Caohejing International
Business Center,
No.391, Guiping Road,
Xuhui District
Shanghai 200233
P.R.China
Telephone: +021-24151000
Market: +021-24151111
Sales: +021-24151188
Service: +021-24151198
E-mail: MTSC-Info@mts.com

MTS Testing Solutions India Pvt Ltd.
No. 38, Ground Floor, Donata Radiance,
1st Cross, Tavarekere Main Road,
DRC Post, Krishna Nagar Industrial Layout,
Kormangala, Bangalore – 560 029
India
Telephone: + 91 80 46254100
Email: mts.india@mts.com



MTS Systems Corporation
14000 Technology Drive
Eden Prairie, MN 55344-2290 USA

ISO 9001 Certified QMS
<http://www.mts.com>

MTS, FlexTest and RPC are registered trademarks and TestLine is a trademark of MTS Systems Corporation in the United States. These trademarks may be protected in other countries. RTM No. 211177.

© 2023 MTS Systems Corporation
100-407-274b TestLineModularComponents • Printed in U.S.A. • 08/23