

FIREBOATS
THEN AND NOW

SPECIAL REPORT



FEMA

U.S. Fire Administration



United States Fire Administration

Major Fire Investigation Program

The United States Fire Administration develops reports on selected major fires throughout the country. The fires usually involve multiple deaths or a large loss of property. But the primary criterion for deciding to write a report is whether it will result in significant "lessons learned." In some cases these lessons bring to light new knowledge about fire -- the effect of building construction or contents, human behavior in fire, etc. In other cases, the lessons are not new, but are serious enough to highlight once again because of another fire tragedy. In some cases, special reports are developed to discuss events, drills, or new technologies or tactics that are of interest to the fire service.

The reports are sent to fire magazines and are distributed at national and regional fire meetings. The reports are available on request from USFA. Announcements of their availability are published widely in fire journals and newsletters.

This body of work provides detailed information on the nature of the fire problem for policymakers who must decide on allocations of resources between fire and other pressing problems, and within the fire service to improve codes and code enforcement, training, public fire education, building technology, and other related areas.

The Fire Administration, which has no regulatory authority, sends an experienced fire investigator into a community after a major incident only after having conferred with the local fire authorities to insure that USFA's assistance and presence would be supportive and would in no way interfere with any review of the incident they are themselves conducting. The intent is not to arrive during the event or even immediately after, but rather after the dust settles, so that a complete and objective review of all the important aspects of the incident can be made. Local authorities review USFA's report while it is in draft form. The USFA investigator or team is available to local authorities should they wish to request technical assistance for their own investigation.

For additional copies of this report write to the United States Fire Administration, 16825 South Seton Avenue, Emmitsburg, Maryland 21727 or via USFA WEB Page at <http://www.usfa.fema.gov>.

FIREBOATS

THEN AND NOW

SPECIAL REPORT

Reported by:

Joseph Ockershausen

Hollis Stambaugh

Seth Kelly

This is Report 146 of the Major Fires Investigation Project conducted by Varley-Campbell and Associates, Inc./TriData Corporation under contract EME-97-0506 to the United States Fire Administration, Federal Emergency Management Agency, and is available from the USFA WEB Page at <http://www.usfa.fema.gov>.

TABLE OF CONTENTS

ACKNOWLEDGEMENTS	I
THE ORIGIN AND DEVELOPMENT OF THE FIREBOAT	1
Safer Ports	3
Safer Ships	5
Shifting Priorities for Fireboats	6
Costs and Benefits.....	7
PERFORMANCE IMPROVEMENTS	10
Multi-Purpose Fireboats.....	16
UNITED STATES COAST GUARD FIRE PROTECTION RESPONSIBILITY	23
Marine Firefighting and Rescue: Staffing, Training and Certification	24
General Elements of an Effective Fireboat Training Program	25
DESIGNING THE (ALMOST) PERFECT FIREBOAT.....	29

ACKNOWLEDGEMENTS

The United States Fire Administration acknowledges the research and contribution of the following people and organizations which provided information supporting this report:

Paul Ditzel

Author, *Fireboats*

Robert Allen, Robert Allen Ltd.

Naval Architects and Marine Engineers

Douglas Barry, Battalion Chief

Los Angeles Fire Department

Brian W. King

Elliott Bay Design Group

Sam Guadagna, Captain (Ret.)

Buffalo New York Fire Department

Frank Zini, Wilkes Barre, PA

Ian Stronach

Author, *An Unusual Fire Boat*

National Fire Protection Association

FIREBOATS

THEN AND NOW

THE ORIGIN AND DEVELOPMENT OF THE FIREBOAT

In 1809, when New York City volunteer firefighters first mounted a crude hand-operated pump on a small boat, the era of the American fireboat was born. The fireboat would not become a mainstay of the American fire service, however, until after the Civil War when the nation moved into the industrial revolution and became a major force in international trade. The need for fireboats escalated with the development of America's ports and waterfronts because of the significant fire risks they posed. In the 200 years since its creation, the fireboat has continued to evolve to meet the changing needs of the fire service. Today's fireboat is a versatile, multi-purpose emergency response platform with proven operational capabilities in a wide range of situations. New designs respond to the changing and more challenging marine environment. With the U.S. Coast Guard increasingly tasked with broader duties related to homeland security issues, some of the waterfront duties normally handled by the Coast Guard are falling to fire departments to cover.

The concept for the first generation of fireboats (those built prior to 1894) was based on the typical steam-powered tugboats found in many harbors following the Civil War. Although not specifically intended for fireboat duty, some of those vessels were fitted with steam-operated pumps and monitor nozzles for auxiliary fireboat use. Even though those vessels were more efficient than hand-operated pumps, many fire service leaders were not convinced of their worth. Used primarily as tugboats to tow and move barges and large ships in and out of ports, the early tugboat "fireboats" were not always available when needed. Also, since they often were equipped with a single boiler, it was difficult to maneuver and to pump water at the same time. These constraints, coupled with the costs associated with purchasing and staffing a fireboat, placed the boats out of the reach of many fire departments.

Some fire departments pursued alternatives that at least reduced the cost factor of fireboats, if not all the operational limitations. They leased harbor tugs and retrofitted them with fire pumps. In 1866, the Fire Department of New York signed an agreement with a local marine salvage company securing the service of the steam-powered tugboat *John Fuller* as its first fireboat on a standby basis. The *Fuller* was capable of pumping 2,000 gallons per minute (GPM) of water, and carried fire hose and salvage equipment.¹

¹ Zini, Frank, *American Fireboats*, Firehouse, May 1978.

As more port cities experienced the devastating effect of harbor fires, some began to purchase fireboats. In 1873, the Boston Fire Department commissioned the *William F. Flanders*, the first American steam-powered fireboat, followed in 1875 by the Fire Department of New York (FDNY), which commissioned the steam-powered fireboat, *William F. Havemeyer*. The *Flanders* and *Havemeyer* were each capable of delivering up to 3,000 gallons of water per minute—an improvement over the 1866 FDNY “fireboat” tugboat that pumped only 2,000 gallons per minute.²

Fireboats commissioned after 1896 ushered in a new era. That generation of fireboats became the basis upon which the modern fireboat is designed. The new fireboats were equipped with multiple, high capacity boilers. These vessels were faster, and capable of delivering large volumes of water at high pressures without affecting the fireboat’s maneuverability. The new fireboats were larger than their predecessors, with some reaching lengths exceeding 125 feet. Their wide beams and deep draft made them very stable in the water. These vessels were designed primarily for one purpose: to deliver large volumes of water at high pressures during a fire.

The internal combustion engine was first introduced into fireboats in 1918. Although more efficient than steam engines, the gasoline engine was short lived due to concerns over the explosive hazard associated with gasoline. By 1927, many of the steam and gasoline powered fireboats either had been decommissioned or were overhauled and retrofitted with the diesel engine or diesel/electric powered motors and centrifugal pumps, which were more efficient and economical to operate. For example, FDNY commissioned the fireboat, *Firefighter*, in 1938. The *Firefighter* was powered by two 1,500 horsepower diesel engines and had four centrifugal pumps capable of delivering 16,000 gallons per minute (GPM). Seattle, Washington’s fireboat, *Duwamish*—commissioned in 1909—underwent an extensive overhaul in 1949 replacing its steam engines with diesel/electric, and increasing its pump capacity from 9,000 GPM to 22,800 GPM.

By replacing steam propulsion and pumping systems with diesel and diesel electric power sources, boat designers were able to incorporate multiple engines and pumps into the same space once occupied by the large steam boilers, steam engines, and pumps. For the first time, propulsion and pumping systems could be separated, allowing fireboats to maneuver and pump at the same time.

² Zini, Frank, *American Fireboats*, Firehouse, May 1978.

This separation of systems solved the problem that early versions of the fireboat had experienced—being in the dangerous situation of choosing between propulsion and pumping.

Many of the early single-purpose fireboats have been retired, but others have undergone extensive overhauls to expand their life and service capabilities. After 60 or more years, many are still in active service. For example, the Buffalo, New York fireboat, *Cotter*, commissioned in 1900, is still in service today.³

Safer Ports

During the late 18th and early 19th centuries large fires occurred at America's ports and waterfronts. These fires frequently required the unique capabilities offered by fireboats. Industrial and commercial structures had proliferated in waterfront cities, resulting in an unprecedented fire problem for much of America's waterfront. The majority of the structures were constructed primarily of wood, and built on or adjacent to wooden wharves and piers. Local building codes during this period were either non-existent or rarely followed in the rush to finish construction of these structures. An article that appeared in the New York publication *The Scientific American* on March 5, 1881, claimed that as many as half of the fires in New York and Brooklyn occurred along the waterfront district.⁴ Other port cities had or were experiencing similar fire problems, for example:

The Great Chicago Fire³

On October 8, 1871, a fire started in a barn in a residential area of Chicago near the Chicago River. The fire spread to the industrial district located along the Chicago River waterfront. As the conflagration grew in intensity it once again jumped the Chicago River, destroying hundreds of factories and commercial structures. In the wake of the fire 300 people were killed, and more than 17,000 homes were destroyed leaving 90,000 homeless, and property loss estimated at \$200 million. Preceding the fire the Chicago Fire Chief's request to purchase a fireboat had been denied, citing that commercial tugboats were a more cost effective to meet city's firefighting needs. Although it was seriously doubtful that a fireboat could have stopped the fire, it may have been effective at reducing firebrands that spread the fire, and supplemented land-based firefighters that were experiencing difficulty maintaining an adequate and reliable water source.

³ Guadagna, Sam, Buffalo Fire Department, *Country's Oldest Working Fireboat Turns 100 This Year*, American Fire Journal, July 2000.

⁴ Ditzel, Paul, *Fireboat*, Fire Buff Division of Conway Enterprises Inc., 1989.

Boston Mercantile District Fire

On November 9, 1872, a fire started in the Mercantile District of the City of Boston. The fire heavily damaged nearly half of the commercial business district and piers located along the city's waterfront. Eighteen hours later the fire started, it had destroyed over 750 structures, killed 15 firefighters, and caused \$75 million in damages. Prior to the fire, the City of Boston had purchased a fireboat; unfortunately, the boat was several months from completion when the conflagration occurred.

The Great Seattle Fire

On June 6, 1889, an accidental fire that started in the basement of a downtown building quickly spread, and involved all structures along the entire waterfront of City of Seattle. By the following morning 29 square blocks of wood and brick structures—including practically all of the city's business district—and all but four of the city's wharves and the city's railroad terminal had been destroyed by the fire. Property damage was estimated at \$15 million. Amazingly there was no loss of life. The City of Seattle purchased its first fireboat following the devastating fire.

Once a significant problem, the fires that plagued many of America's port cities now account for only about 20 percent of the response activity of fireboats today. The decline in firefighting activities can be attributed to several factors. Mostly, it can be associated with the progress that cities and ports have made in upgrading and modernizing facilities. Port improvements have been driven by requirements to accommodate the next generation of super ships, including mega container ships. Improved cargo handling and storage capabilities, as well as improvements in ship fire suppression and detection design, contribute to more fire safe ships and ports.

The old wooden warehouses, wharves, and piers that once dominated many ports and waterfronts—and which fueled many of the devastating fires—are rapidly disappearing and being replaced by new fire resistant structures, concrete wharves, and concrete piers. For example, the Los Angeles and Long Beach, California harbors are the busiest ports of entry on the West Coast. In 1996, the Port of Los Angeles began the largest harbor renovation and expansion project ever undertaken in the United States. The project involved the replacement of the Port's 26 miles of wooden wharves with modern concrete docks and open cargo loading facilities to facilitate loading and off-loading of containerized cargo, petroleum, and chemical shipments.

According to a 1990 article in 9-1-1 Magazine by Paul Ditzel, containerization has transformed the way cargo is handled. Break-bulk cargo that once sat in the holds of vessels and in port facilities now is mostly shipped in fire-resistant metal containers.⁵ In 2001, approximately 16 million containers passed through U.S. ports. Containerized cargo makes it possible to quickly load and off-load ships, and to transfer cargo containers to various modes of ground transportation for movement to inland destinations across the country. Break-bulk cargo no longer sits on wooden piers or wharves, or in unprotected warehouses awaiting transport, so the risk of fire is substantially reduced. According to a 1997 United States Maritime Administration report to Congress, if America is to remain competitive in world trade, then U.S. ports must face the challenge of handling the next generation of container ships: mega-ships.

World trade is growing; nearly 55 percent of all general cargo in international liner trade is shipped in containers. According to the Committee on Government Affairs by 2010, they expected that 100 percent of general cargo received by American ports will be containerized. Mega-container vessels will have the capability of transporting between 4,500 and 9,000 cargo containers. To accommodate the new generation and volume of cargo vessels, many U.S. ports have begun major expansion projects upgrading their terminal facilities to handle such vessels. Improvements include the following:

- larger cranes to facilitate the loading and un-loading of containerized cargo;
- larger mooring berths and storage yards;
- better roads, including on-dock rail facilities, and
- safer facilities built to current fire codes.

Safer Ships

The new generation of ships being designed and constructed today are inherently safer than the ships of the past. The Safety of Life at Sea (SOLAS) Treaty, and the American Bureau of Shipping (ABS) are organizations that establish and administer standards governing the fabrication and safety of vessels. SOLAS is regarded as the most important of all international treaties concerning the safety of merchant vessels. The organization's primary objective is to specify minimum standards for the construction, equipment, and operation of ships, compatible with their safety. These standards include structural fire protection for ships, fire suppression, and detection systems, as well as the International Code for Fire Safety Systems (FSS code) and the Fire Test Procedures Code adopted in 2001.

⁵ Ditzel, Paul, *New Hook in Fireboats*, 9-1-1 Magazine, September 1990.

Flag states are responsible for ensuring that all ships operating under their flag comply with SOLAS requirements. ABS establishes and administers standards for the design, construction, and operational maintenance of marine vessels and structures. Although marine vessels still experience fires, their frequency and severity have been significantly reduced.

The United States Coast Guard (USCG) has traditionally played a major role in ship and port safety. Aside from the ship and boating safety inspections conducted by the USCG, the Captain of the Port (COTP) possesses the authority for directing Coast Guard law enforcement efforts within their jurisdiction. The COTP enforces all regulations concerning the protection and security of vessels, harbors, and waterfront facilities, anchorage, bridges, safety and security zones, and ports and waterways. The COTP also provides assistance and support at major fires on board vessels and at waterfront facilities. The COTP also is responsible for developing an organized firefighting contingency plan that addresses firefighting operations in each port within the COTP zone.

Shifting Priorities for Fireboats

Although port modernization projects have reduced the frequency of fires, port improvements have at the same time created new challenges and service demands for fire departments. Many cities and port authorities have undertaken ambitious waterfront development projects in conjunction with port upgrades, which have transformed waterfront property into multi-use, high-density properties. These development projects often consist of small marinas generally used by recreational boats. Others contain high-rise office and commercial businesses such as hotels and shopping districts like those found in Baltimore City's Inner Harbor; Norfolk, Virginia's Waterside Festival Place; San Francisco's Fisherman's Wharf; Los Angeles's Marina Delray; and others.

These kinds of waterfront developments appeal to many people and can attract thousands of visitors annually, thus creating a life safety concern for fire and rescue personnel. Waterfront emergencies, and fires in particular, can be a challenge for the best fire departments. Fires in such areas can present significant logistical and tactical problems for land-based fire units because of poor or limited access. Fire personnel may be forced to carry equipment and/or stretch hose lines long distances to attack a fire. A fireboat can give the fire chief a tactical advantage in such situations because in many cases fireboats have unfettered access to waterfront structures that allows them to quickly maneuver into position and commence firefighting and/or support operations. The fireboat can serve as an excellent command post and/or fire sector

during major waterfront fire and rescue operations. Fireboats can communicate fire conditions from a unique perspective to the incident commander.

The fireboat also is an excellent platform for delivering personnel and equipment to support land-based fire operations. The tremendous pumping capacity of fireboats allows them to supply land-based units large volumes of water at high pressures through large diameter hose and nozzles over long distances. In some cases, one fireboat can have the same water delivery capacity as almost 40 land-base pumpers. For example, the Los Angeles Fire Department Fireboat Two can deliver 38,000 GPM.⁶

With pleasure boating gaining popularity, the number of small marinas is on the rise. Navigating a vessel in a small marina can be a challenge. Many of these marinas are located in shallow waters and have narrow passageways between docks. It is difficult for deep draft vessels, such as many of the larger fireboats, to maneuver in narrow and shallow waterways. This situation is exacerbated in tidal waters where the depth of water is constantly changing. Fireboat crews must remain vigilant and continually monitor their time on station along with the depth of water in which they operate so that they are prepared to withdraw to deeper water to avoid becoming grounded.

A more common problem encountered by larger fireboats is the large wake they create. Small vessels moored at docks and marinas have sustained serious damage when they are violently tossed against docks and other craft by the wakes that fast moving deep draft vessels (such as some fireboats responding to an incident) create when they pass through narrow waterways.

Costs and Benefits

Fire departments that have had fireboats periodically assess whether the benefit of a fireboat justifies the expense. Some departments have retired their fireboats; other departments have reduced the number of fireboats in their fleet of vehicles. To get a better idea of the capacity, usage, staffing, and special features of today's fireboats, nine fire departments were contacted and asked questions about their marine firefighting capabilities and the demand for this service.

⁶ Vaccaro, Bob, *Firefighting On The High Seas*, Fire Rescue Magazine, May 2003.

The departments that contributed to the research included the following:

- New York, NY
- San Diego, CA
- Chicago, IL
- New Orleans, LA
- Jacksonville, FL
- Baltimore, MD
- Houston TX
- Philadelphia, PA
- Boston, MA

Table 1 illustrates the dilemma that many public officials are confronted with regarding cost versus demand for fireboat services. For example, the Port of Philadelphia is the sixth busiest port in the United States with over 2,700 ports of call made annually by commercial vessels. Yet their fireboats average only one response every two weeks. Such a low call volume calls into question the need for two fireboats. However, after factoring in the size of the coverage area and the potential for extended response times, an argument can be made for maintaining both fireboats. In comparison, the Port of New York is the fourth-busiest port in the U.S. with over 4,600 ports of call made annually. Each of the FDNY active service fireboats averages 5.2 responses per week. The size of the response and frequency of responses answered by the marine division easily justify the need for at least three fireboats. Survey data shows that the average number of fireboat responses to be just under two responses per week.

Table 1. Fireboat Response Data for 1999 – 2001				
<i>Fire Department Respondents</i>	<i>Number of Fireboats</i>	<i>Total Fireboat Responses 1999 - 2001</i>	<i>Average Annual Fireboat Responses</i>	<i>Average Weekly Response per fireboat</i>
Houston, TX	3	447	149	.95
Jacksonville, FL	3	796	265	1.7
New York, NY	3	2420	807	5.2
Baltimore, MD ¹	2	399	133	1.3
Philadelphia, PA ²	2	163	54	.52
San Diego, CA	2	859	286	2.8
Chicago, IL	1	415	138	2.7
New Orleans LA ³	1	300	100	1.9
Boston, MA*	N/A	N/A	N/A	N/A
Category Averages	2.1	N/A	N/A	2.1

1. Baltimore FD maintains four fireboats, two in active service, and two in reserve. The average weekly response data was calculated based on two in-service fireboats.

2. Philadelphia FD maintains three fireboats, two in active service, one in reserve.

3. Data provided by New Orleans Port Authority represented approximate number of responses.

*Boston's fireboat response data was not available.

Many fire and port officials believe that the declining number of fire calls coupled with escalating costs associated with providing water-based fire suppression have made fireboats too expensive to maintain. Six of the nine fire departments and port authorities contacted reported permanently placing a fireboat out-of-service for a variety of reasons. Four of the five fireboats were placed out-of-service because of their age and for budget cutbacks. Some fire departments have elected to completely eliminate fireboat service, thus shifting the burden of marine fire and rescue services to the local port authority or other commercial interests. Fire departments with more than one boat have either decommissioned older boats or expanded their service capabilities to justify maintaining fireboat service. Expanded services include:

- search and rescue operations;
- platform for launching SCUBA operations;
- conducting harbor safety patrols;
- assisting disabled boaters;
- hazardous materials mitigation; and
- others, depending on the special needs or interest of individual ports.

Cost should not be the only factor considered when determining whether to keep a fireboat or acquire one. Although the frequency of major fire activity may have declined at most ports, the hazardous materials associated with port operations—and new waterfront development projects such as those described earlier—still represent a serious challenge for fire and rescue personnel. Neither should a fire department simply compare the number of fireboats to the number of responses and try and use that to determine what is a reasonable number of fireboats from that comparison alone. Other factors must be considered, such as:

- the age and condition of the existing fireboat;
- the estimated cost to upgrade the fireboats capabilities;
- the size and speed that the fireboat(s) is capable of achieving;
- pumping capacity;
- fire and rescue equipment carried; port activity levels (commercial and domestic);
- the number, type and level port hazardous operations;
- condition of port facilities;
- projected port improvements;
- type of responses;
- current response activity; and
- anticipated response activity.

Fire and port officials must exercise prudent judgment, carefully evaluate all of these issues, and then balance the potential risks with a reasonable level of marine fire and rescue service.

PERFORMANCE IMPROVEMENTS

A vessel's performance and operational characteristics are greatly influenced by its design. The push to improve fireboat performance and operational capabilities dates back as early as the 1970s. In 1973, the United States Maritime Administration published a report outlining basic fireboat specification and capabilities, which parallels many of today's standards published by NFPA governing marine firefighting vessels. The report called for fireboats to meet certain requirements including the following:⁷

- capable of being operated by a two-person crew;
- able to perform in rough seas with up to six foot waves;
- have a dash speed of at least 30 knots;
- have a shallow draft and low wake;
- achieve and sustain a patrol speed from 3 to 10 knots;
- have a 20-year hull life;
- be capable of pumping 5,500 GPM for at least 8 hours;
- be equipped with multiple firefighting monitors;
- demonstrate high maneuverability; and
- have the capability to allow personnel access to decks of larger vessels.

Many fire departments are transitioning from the larger traditional fireboat design to smaller, faster, and more versatile craft designed and configured for a multiplicity of operational roles. These multi-purpose fast response fireboats have clear operating advantages over their earlier counterparts. Advances in hull design, made possible in part through the use of lightweight metals and composite materials, have resulted in lighter and faster craft with better maneuvering capabilities. For decades, most fireboats relied on a single power source (engine) to provide propulsion and water delivery. If the only engine were to fail, the boat and crew could be in serious jeopardy especially if operating close to a large fire. Improvements in propulsion and pump technology have enabled boat designers to incorporate independent pumping and propulsion systems into new fireboat designs. Most fireboats are now capable of delivering water without sacrificing maneuvering capabilities.

⁷ Zini, Frank, *American Fireboats*, Firehouse Magazine, May 1978.

Hovercraft technology, such as that used in Surface Effect Systems (SES), has been used for many years in marine firefighting in Europe and Asia. Vessels using SES technology skim along the surface of the water on a cushion of air encapsulated beneath the vessel. Fans (number depends on the size of vessel) provide the downdraft that lifts the craft above the surface of the water reducing drag, and allows the craft to obtain higher speeds than conventional drive systems. Traveling above the surface of the water also protects the hull from sustaining damage from objects on or just below the surface of the water.⁸

The Tacoma, Washington, Fire Department was the first fire department in the United States to employ SES technology. The department also incorporated many of the recommendations contained in the 1973 U.S. Maritime Administration's report. The Tacoma SES model was designed using a twin fiberglass catamaran hull equipped with airtight flexible skirts (seals) at the bow and stern (see Diagram 1). Skimming across the surface of the water on a cushion of air this 70-foot fireboat is capable of obtaining speeds in excess of 36 knots under normal weather conditions, and 20 knots in six-foot waves. The craft produces a maximum wake of 18 inches at all speeds, which is excellent when compared to the large wakes created by many deep draft vessels at lower speeds.⁹

The Tacoma's fireboat has independent propulsion and pumping systems and is capable of delivering 5,500 GPM without affecting the craft's maneuvering capabilities. The vessel is equipped with five monitor nozzles, one 5,500 GPM, two 2,500 GPM, and two 2,500 GPM under dock nozzles. All nozzles are remotely controlled, which reduces the number of personnel necessary to operate the vessel. The boat's low-profile hull and remote control dock nozzles mounted just above the waterline provide greater penetration and access to fires on the underside of wharfs and piers. Its shallow draft also makes the vessel easier to maneuver in shallow waters, and less susceptible to problems associated with tidal changes. The fireboat is equipped a wide variety of tools and equipment to conduct fire, environmental and search and rescue operations such as: hydraulic/telescoping ladder, foam, resuscitators, aspirator, stretchers, and medical supplies. It is also equipped to support scuba diving operations. Another innovative and cost saving feature was that the Tacoma fireboat is designed to be operated by as few as two personnel, although a crew of three is used for safety purposes.

⁸ Ditzel, Paul, *Fireboat*, Fire Buff Division of Conway Enterprises Inc., 1989.

⁹ City of Tacoma Fire Department, *Multi-Purpose Harbor Service Craft*.

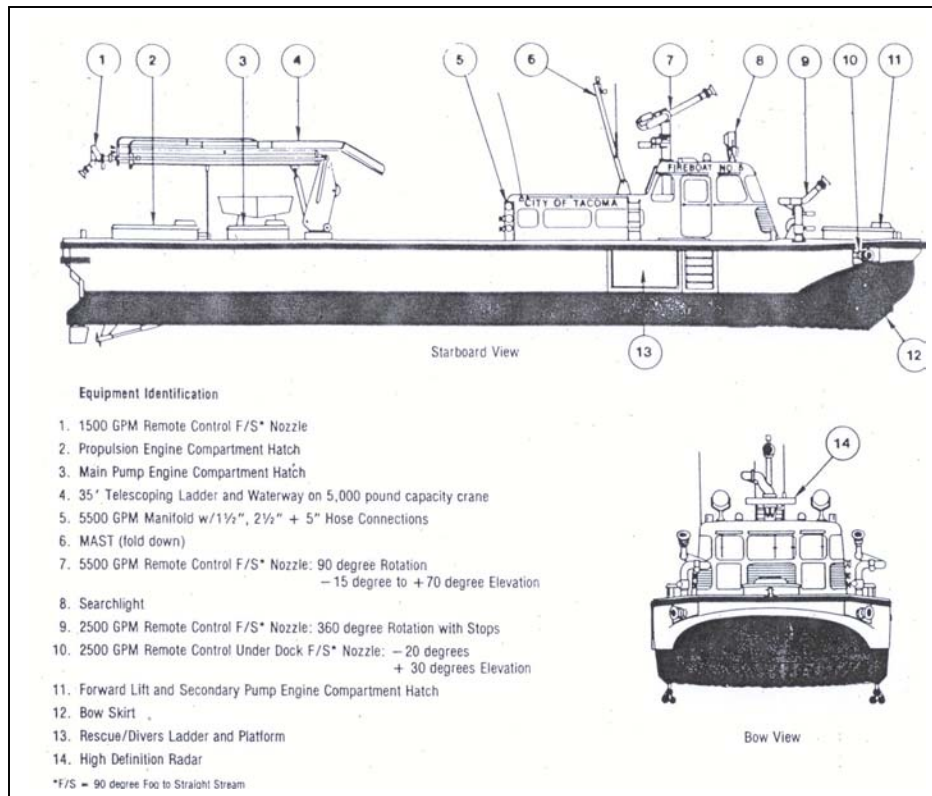

Courtesy of Tacoma WA Fire Department

Critical to the performance of any fireboat are the propulsion systems that propel them through the water. The conventional, fixed pitch propeller powered by a diesel engine is perhaps the most economical and mechanically sound propulsion system. (A Conventional Propulsion System is illustrated in Diagram 2, below.) According to a 1998 study conducted by the Elliott Bay Design Group of propulsion systems, they found the Conventional Propulsion System to be proven and reliable.¹⁰ And over a relatively narrow speed range, the Conventional Propulsion Systems provide the best overall propulsive efficiency of all propulsion systems for small vessels. The hull design for the conventional propeller with rudder can also be configured so that the vessel is suitable for shallow water operations.

¹⁰ King, Brian W., *Propulsion Systems*, Elliott Bay Design Group, April 1998.

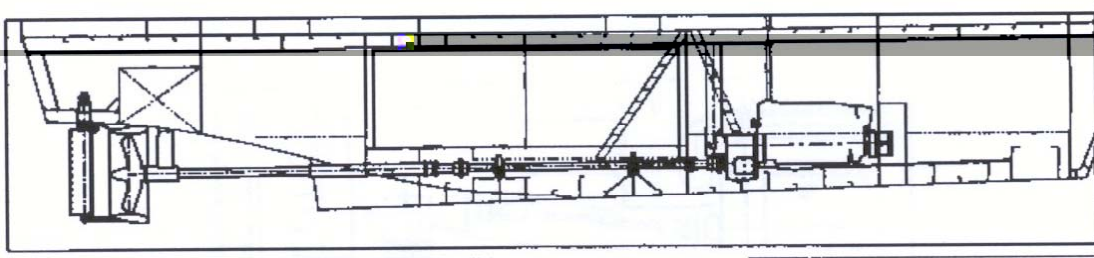

Illustration 1
Conventional Shafts & Propeller

Diagram 2. Conventional Propulsion System

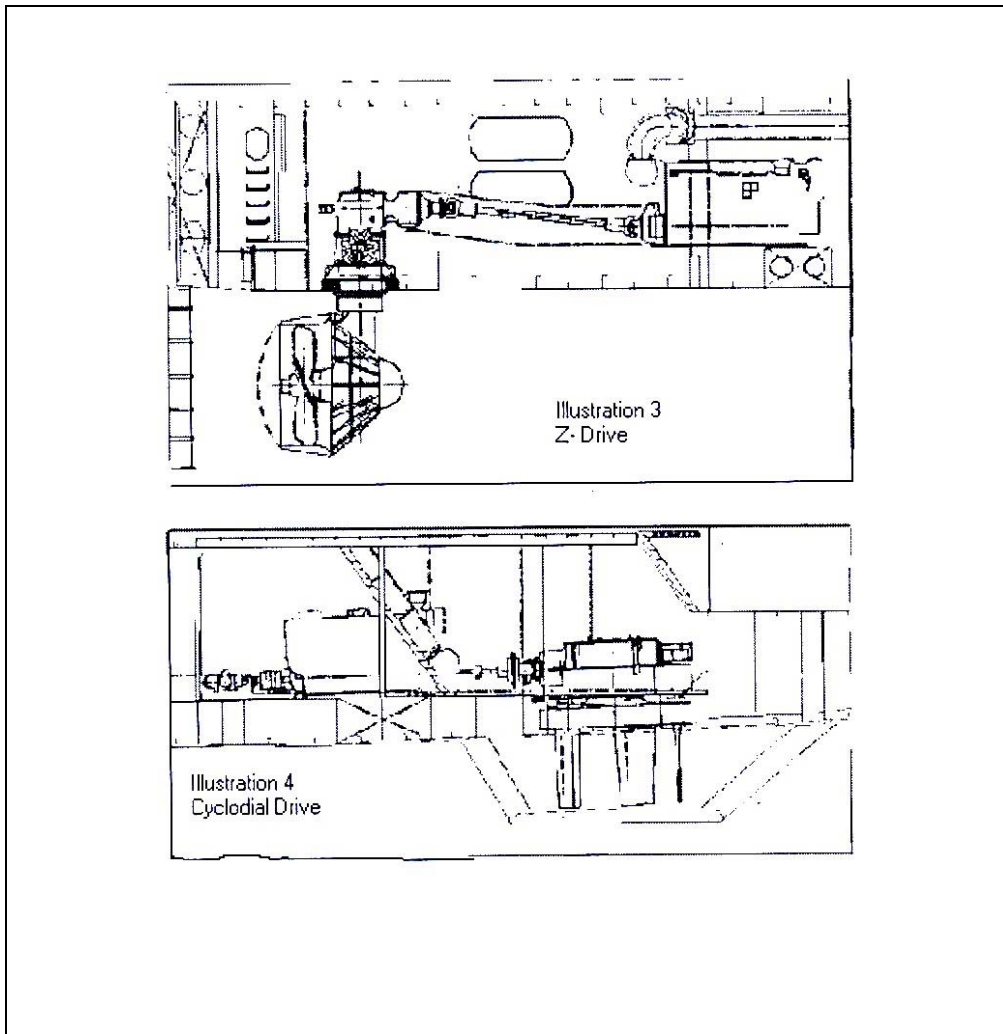

Diagram 3. The Z and Cyclodial Drive Systems

Relatively new propulsion systems such as the Z and Cyclodial drive systems are gaining popularity in fireboat design. The Z and Cyclodial are drive systems that incorporate both propulsion and maneuvering functions in a single unit. (The Z and Cyclodial drive systems are

Courtesy of Elliot Bay Design Group

Courtesy of Elliot Bay Design Group

illustrated in Diagrams 3 and 4) Steering using either of these propulsion systems is accomplished by directing the thrust of the propulsion unit (similar to an outboard motor) in any direction eliminating the need for a rudder. These drive systems provide the maximum possible maneuverability and directional control for a vessel operating in very confined and congested waterways and harbors which make them attractive for use in fireboats. The Los Angeles Fire Department's newest fireboat (see Diagram 4, *Fireboat 2*) is equipped with twin Cyclodial drives. Although considered robust and reliable propulsion systems, the Z and Cyclodial drive systems are not suited for all vessels because the main drive components extend below the hull of the vessel the drive components create a deep draft situation and thus are generally not a good choice to use on small craft designed for shallow water operations.¹¹

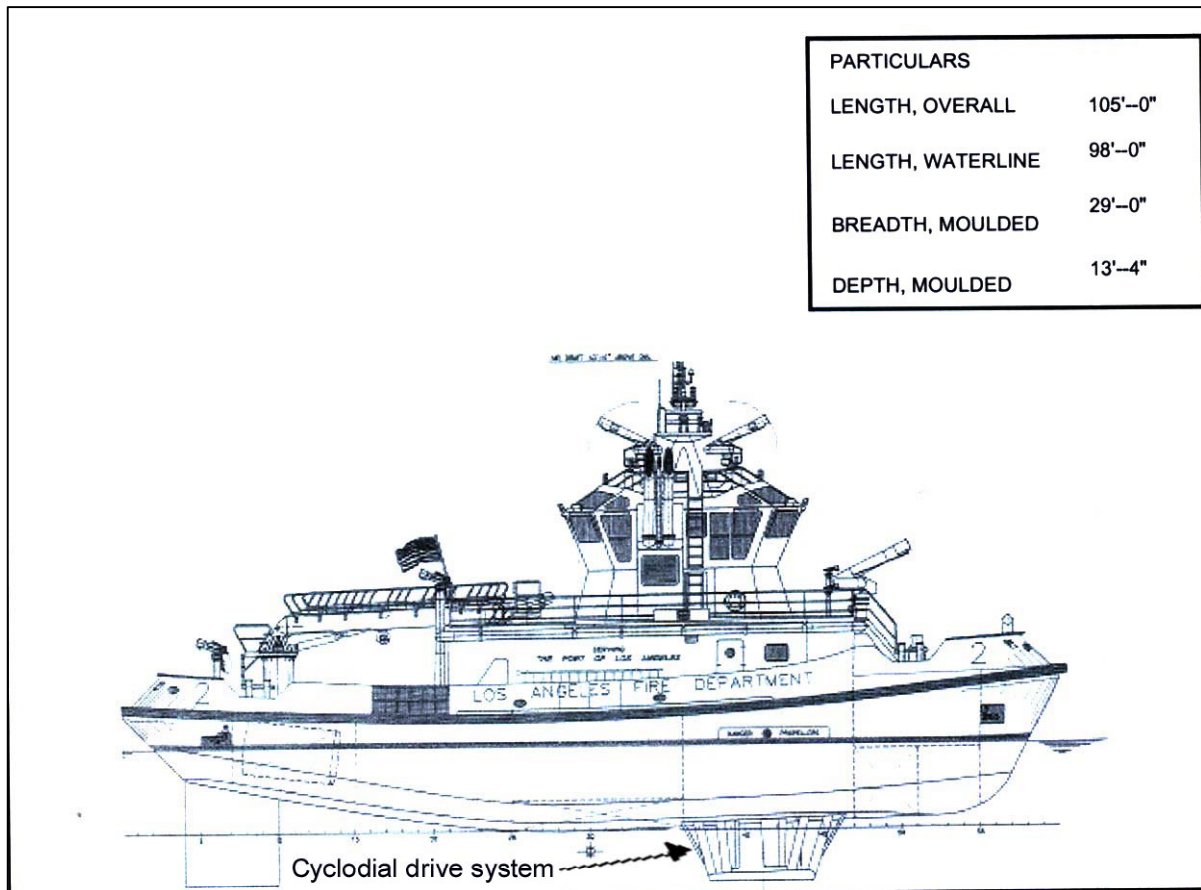

Courtesy of L.A. Fire Department

Diagram 4. L.A. Fireboat 2

¹¹ King, Brian W., *Propulsion Systems*, Elliott Bay Design Group, April 1998.

Once used exclusively on small, high-speed craft waterjet propulsion systems have growing in popularity for use on larger craft. (A waterjet drive system is illustrated in Diagram 5) They are more efficient than conventional propeller driven craft at speeds exceeding 25 knots. Waterjet propulsion systems capable of providing efficient maneuverability at slow speeds at slow speeds are now being incorporated into the design of fireboats. Waterjet propulsion is ideal for shallow water operations. Craft using this propulsion system can generally be beached or sit on the bottom without fear of damaging the propulsion system. Waterjet propulsion is safer for divers than any other propulsion option.¹²

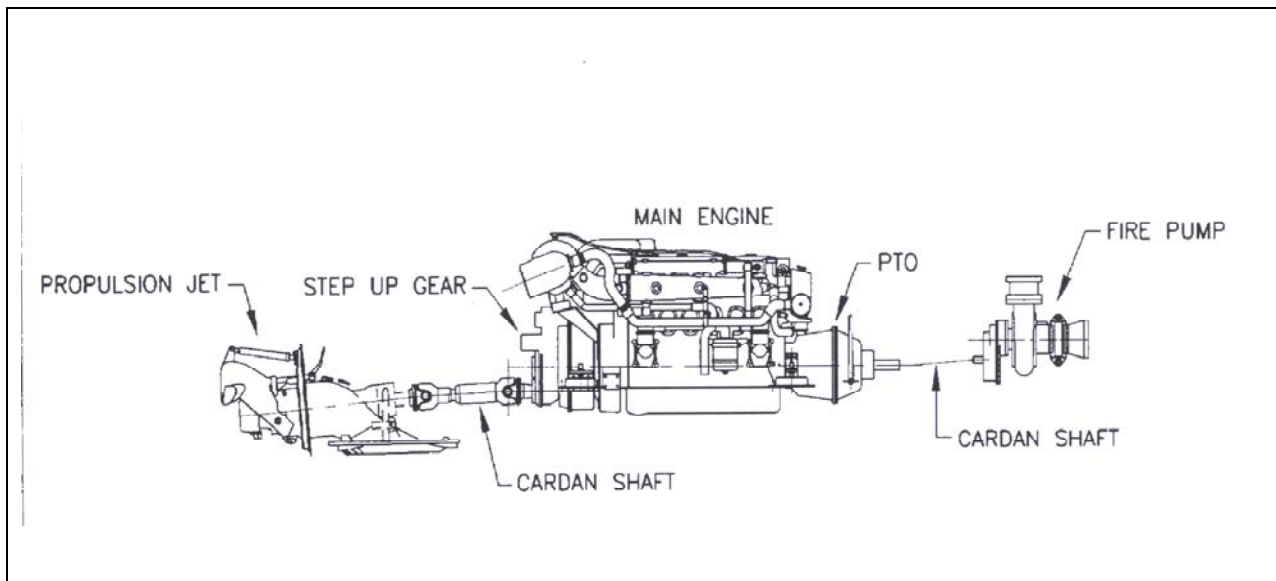

Courtesy of Robert Allan

Diagram 5. L.A. Fireboat 2

The Port of Vancouver British Columbia operates a fleet of five fireboats, all of which have twin waterjet propulsion systems.¹³ These 40 ft. reinforced aluminum hull craft have a maximum speed of 32 knots and a service speed of 25 knots. The fireboat's low hull profile and shallow draft make the craft an ideal diving platform and for use during shallow water operations. Twin pumps powered by the two primary drive engines are capable of delivering a total of 3000 gallon of water per minute. Waterjet bow thrusters powered by the main engines compensate for the vessel's drift and movement during fire suppression operations. (See Diagram 6 for a profile of the standard Vancouver fireboat and twin waterjet propulsion systems.)

¹² King, Brian W., *Propulsion Systems*, Elliott Bay Design Group, April 1998.

¹³ Robert Allen Ltd., *The Planning, Designing, and Construction of Fast Response Fireboats For The Port of Vancouver*, April 1995.

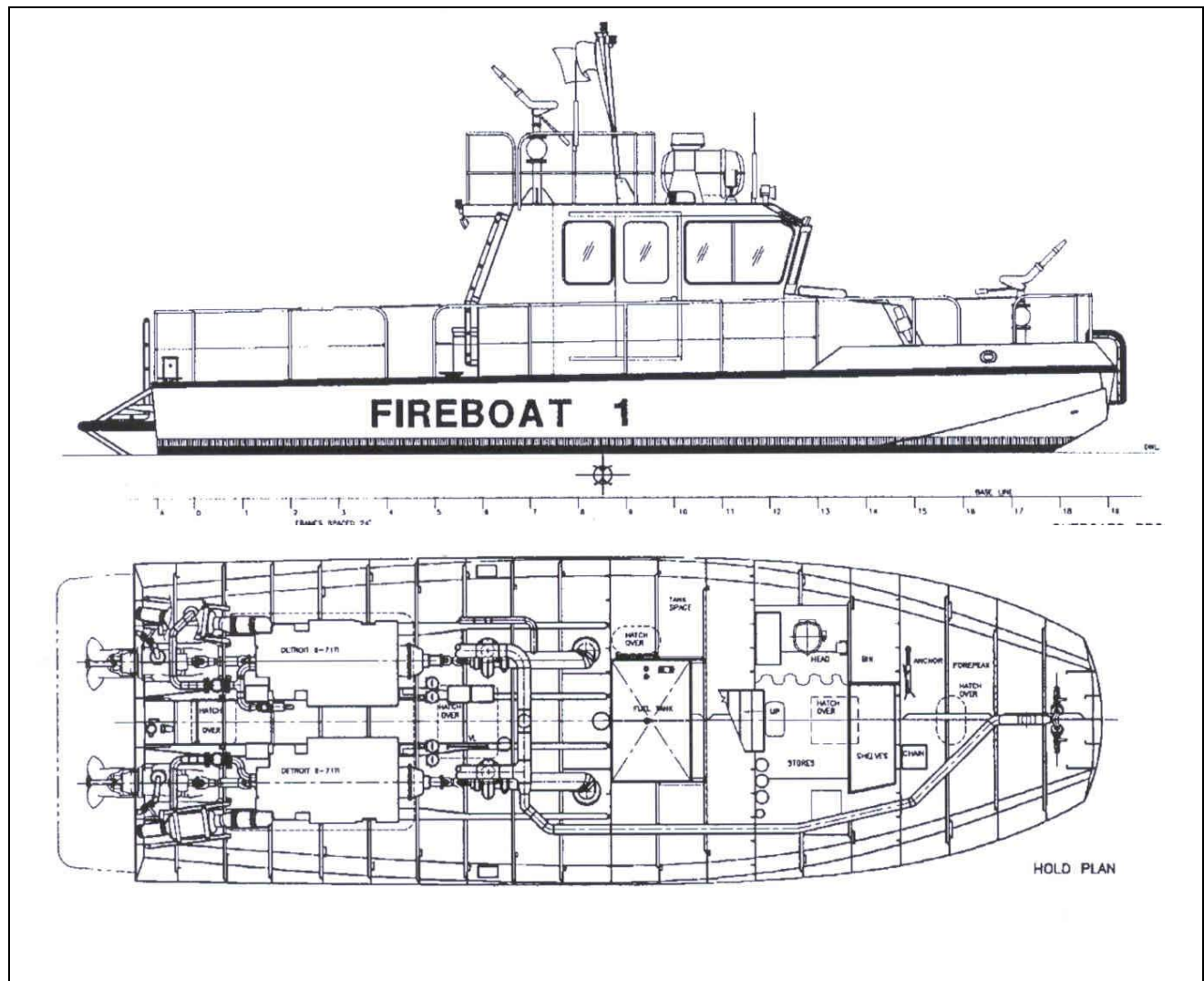

Diagram 6. Profile of the Vancouver fireboat twin waterjet propulsion systems

During firefighting operations, the water discharged through the fireboat’s fixed fire suppression systems (such as monitor pipes) results in significant nozzle reactions. These can affect the fireboat’s maneuvering ability. Some fireboats are equipped with steering thrusters, which are designed to counteract the forces created by water flowing from nozzles under high pressure. This system works by directing water under pressure through nozzles under the hull or through ports in the side of the vessel’s hull at the waterline to counteract any nozzle reaction, thus holding the vessel in position during firefighting operations.

Multi-Purpose Fireboats

According to the National Fire Protection Association, the mission of the fireboat has changed. Routine fireboat duties now encompass many different kinds of emergency and non-

emergency operational scenarios that just a few short years ago would have been considered outside of the scope of traditional fireboat operations. Fireboats serve three basic functions:

- They serve as vehicles for conducting rescue operations and transporting personnel and equipment to and from incidents that are inaccessible from shore by land-based firefighters.
- The fireboat provides a stable platform for conducting and supporting marine firefighting operations. Fireboats serve as forward operational command posts for marine and some land-based fire operations, rescue and recovery missions, and marine environmental emergencies.
- Fireboats also play a critical role in water supply in many kinds of land-based fire operations, and during natural and man-made disasters.

The new multi-purpose craft is usually smaller than earlier fireboats. The smaller size, in many cases, requires fewer crew to operate the vessel, and makes the craft more attractive to many fire departments. The new multi-purpose boats possess a tactical advantage over the traditional (larger) fireboat. Many new fireboats have shallow drafts that permit them to be easily maneuvered and operate in shallow and narrow waterways, and create a smaller wake than their larger counterparts, when in operation. Their smaller size coupled with an optimal propulsion system results in a vessel capable of quickly covering long distances in as little as half the time it would take a larger fireboat. The speed of multi-purpose craft allows them to quickly reach an incident and begin mitigation efforts, long before many of the older fireboats could have arrived at the scene. Some cold-water ports have designed fireboats with reinforced hulls that allow them to navigate frozen ports and tributaries; fireboats also serve as icebreakers to open ports and keep marine traffic moving.

The European counterpart to the multi-purpose fireboat design concept is the rapid response boat. These craft share many of the same basic design and operational characteristics as the U.S. boats. For example, the London Fire and Civil Defense Authority replaced the 15-year old fireboat, *the London Phoenix* with two smaller lightweight aluminum mono-hull rapid-response boats. Both craft have a dedicated crew of four personnel and the capacity to support five additional land-based personnel. Both boats are powered by twin diesel engines and waterjet drive propulsion systems enabling them to reach speeds of up to 30 knots, as opposed to a top speed of 12 knots by the *Phoenix*. Each craft has a pump capacity of 500 gallons of water per minute. Their low profile shallow draft mono-hull design allows the boats to operate in the shallow

estuaries, and under the low bridges within the River Thames service area. Both craft are capable of operating in ocean waters up to three miles from shore. The craft carry a wide variety of firefighting equipment, and an onboard generator with 240/110 volt AC power.

Some fire departments have initiated policies and tactics that take advantage of the unique capabilities that both the large traditional and the multi-purpose fireboats have to offer in an emergency. Multi-purpose craft will often respond first. Their smaller size and speed allow them to reach an incident in as little as half the time that it would normally take the larger traditional type fireboat. Most of the time, the multi-purpose fireboats have the equipment and capabilities necessary to effectively handle the emergency situation. However, if the situation requires more capabilities, the larger fireboat can be dispatched to assist.

The proliferation of small marinas and the increasing number people who enjoy water activities have made the fireboat a critical resource for search and rescue missions, both locally, and at sea. Water-related-rescues comprised 40 percent of the fireboat responses reported by eight fire departments. Table 2 shows all fireboat response data for 1999-2001 from the eight fire departments that provided this data.

Table 2. Types of Fireboat Responses Data 1999-2001				
<i>Fire Department Respondents</i>	<i>Total Responses</i>	<i>Fire Responses</i>	<i>Water Rescues</i>	<i>Other**</i> <i>Responses</i>
Baltimore, MD, FD	399	346 / 87%	53 / 13%	N/A
Jacksonville, FL, FD	796	193 / 25%	486 / 75%	N/A
Philadelphia, PA, FD	163	40 / 25%	123 / 75%	N/A
Port of Houston, TX	447	32 / 7%	15 / 3%	400 / 89%
San Diego, CA, FD	858	88 / 10%	300 / 34%	470 / 56%
Chicago, IL, FD	415	62 / 15%	353 / 85%	N/A
Port of New Orleans, LA	300	90 / 30%	30 / 10%	180 / 60%
New York, NY*	N/A	N/A	N/A	N/A
Boston, MA*	N/A	N/A	N/A	N/A
Response Data Summary	3378	851/25%	1360/40%	1050 / 31%

* Response data was not available for the New York and Boston Fire Departments

** Other responses include: shore patrol, assisting swimmers, hazardous material (environment responses), performing other assigned harbor duties, SCUBA operation other than during firefighting.

Ports typically are a major location for hazardous materials, which are present on vessels in transit, at on-site manufacturing sites, and in bulk storage facilities at the port. Massive ships that

import and export bulk shipments of hazardous cargos are another concern. The increase of containerized cargo creates a parallel increase in the percentage of containers having some kind of hazardous material. Hazardous materials are not always properly manifested when shipped and could pose a significant danger for unsuspecting fire suppression personnel. It is estimated that nearly 50 percent of all containers hold some of hazardous material.

The growing number of larger container ships can cause congestion at the terminal. If a container is positioned deep in a stack and is leaking or is on fire, it may be quite difficult to access. Multi-purpose craft can play a critical role in lessening the environmental impact of marine hazardous materials. Fire departments and port authorities that operate fireboats equip their boats with bayonet nozzles (for piercing dense stacks of containerized cargo to extinguish fires), containment booms, foam, skimmers, absorbents, and other equipment. This equipment is used to mitigate fires and environmental emergencies, such as oil spills and the release of other hazardous substances into ports and waterways.

Ports and waterfront are not immune to criminal activity. Illegal acts are problems affecting all ports throughout the world. The issue of criminal activity has taken on a new meaning and concern in light of the September 11, 2001, terrorist attacks. In view of the nation's heightened security, the mission priorities of the United States Coast Guard (USCG) have been altered. Some of the USCG vessels and other assets that generally were used in local water-related emergencies, might not be available to respond given other security related duty assignments. It may become necessary for local emergency services to fill this void.

Fireboats are ideal service platforms for launching and supporting SCUBA diving operations. The Los Angeles Fire Department pioneered underwater firefighting operations. After experiencing several major wharf and pier fires at the Port of Los Angeles, the LA Fire Department established a highly specialized and successful SCUBA diving team to conduct firefighting operations from positions just under the surface.

In addition to marine firefighting and rescue operations, fireboats, often are called upon to support land-based firefighting operations, especially during disasters. Fireboats were important assets at the Loma Prieta, California earthquake and the September 11, 2001, World Trade Center terrorist attack. During such catastrophic events the enormous pumping capacity of fireboats enables them to supply water to land-based fire units. This is done through dockside water manifolds and large diameter hose, carried on many fireboats, or they can simply anchor in deep water offshore and supply fire units ashore. One fireboat can supply as much water as 30 or more street pumpers.

Case Study #1

Matson Dock Fire Los Angeles CA

Underwater (SCUBA) Firefighting Team from Fireboat

On St Patrick's Day, 1960 the Matson Dock fire occurred in Los Angeles. A spark from a welder's torch started a fire aboard a lumber barge tied up at berth 200-A in the Los Angeles Harbor. The fire quickly spread to the adjacent wharf, and consumed approximately 1,100 feet of dock before being controlled.

At the time of the fire the Port of Los Angeles had more than 28 miles of wooden wharves. The pier was constructed against a concrete and rock bulkhead making it inaccessible to land-based firefighters, and approachable only from the water. The wharf was made of heavy timber and planking, and was impregnated with creosote or oil to retard deterioration from the salt water and wind. Such construction can enable fire to spread beneath the decking where it can travel out of reach of hose streams and fireboats, depending on the tides.

The conventional method for attacking a fire like the Matson Dock fire would involve firefighters breaching the decking well ahead of the fire and inserting distributor nozzles to stop the fire's spread. However, such tactics are labor intensive, and not always successful. Even fireboats are sometimes not successful in fighting such fires. Depending on the height of the tide, an older fireboat may have difficulty attacking the fire because their monitor pipes may either be above the decking at high tide, or unable to reach the seat of the fire because of the maze of lumber beneath the wharf. A more effective method for fighting these types of fires was needed.

While conducting overhaul operations on the Matson Dock fire, the Los Angeles Fire Department determined that it might be possible for SCUBA divers to attack a wharf fire from below. Divers attempted to prove this theory by snaking a charged hose line around piling to extinguish hot-spots on the underside of the decking. Much to their surprise, their experiment was successful. They now envisioned a radical new tactic for attacking future wharf fires -- utilize trained firefighters using SCUBA gear to make direct attacks to the underside of burning wharfs. Flotation devices were developed as platforms to support and allow divers to maneuver and operate hoses and nozzles in the water. Currently, divers operate from three of the Los Angeles Fire Department's five fireboats. These craft measure 40 feet in length and are capable of achieving speeds of approximately 30 knots, and have the water delivery capability of 2,400 GPM.

Case Study #2

1989 Earthquake, Loma Prieta California

The Phoenix Pumps 5.5 Million Gallons

On October 17, 1989, an earthquake measuring 7.1 on the Richter scale struck San Francisco. The epicenter was located approximately 10 miles northwest of Santa Cruz along a segment of the San Andreas Fault, near Loma Prieta in the Santa Cruz Mountains. The earthquake caused 22 structure fires throughout the city and over 500 related incidents (e.g., gas explosions, blocked streets, etc.) during the seven hours following the earthquake. Over 300 hundred firefighters were recalled to assist on-duty firefighters fight the fires and mitigate other emergencies resulting from the earthquake.

The most serious incident occurred at the intersection of Divisadero and Jefferson Streets in the Marina district. The Marina district is a densely populated area with predominately 1920 vintage wood frame structures, consisting of two-story apartment buildings over garages, and single-family homes. A three-story building on the corner of Divisadero and Jefferson was on fire and threatened to spread to adjacent structures, and to already collapsed buildings across the street. The first arriving engine company connected to the city's Auxiliary Water Supply System (AWSS) in front of a building that had partially collapsed. The AWSS is a high-pressure water supply system that was built following the 1906 San Francisco earthquake.

Shortly after the Department's arrival, an explosion occurred within the partially collapsed structure, causing the rest of the structure to collapse onto the fire hydrant. At approximately the same time, fire units began to experience water supply problems due to leaks in the municipal water system as well as in the high-pressure system. Fire units were forced to abandon their positions. Hose lines were stretched four blocks to an alternate water source. Several more explosions occurred resulting in the collapse of exposed structures onto the supply lines just laid. Additional assistance was summoned.

At 6:00 p.m. the fireboat, Phoenix, arrived on-scene in the Marina lagoon approximately two-blocks away, followed by the Fire Department Portable Water Supply System (PWSS) Hose Tender with 5,000 feet of 5-inch diameter hose at 6:40 p.m. The fireboat was able to supply water to Hose Tender 25 as well as to Hose Tender 8 that arrived a short time later. The fire had progressed to a point where the entire neighborhood was threatened by the fire. Using the PWSS, the Phoenix was able to supply an additional engine company and two ladder trucks. The Phoenix pumped over 6,400 GPM continuously for 15 hours, (approximately 5.5 million gallons of water) until the fire was brought under control.

Case Study #3
New York City - World Trade Center Collapse
September 11, 2001

Five Fireboats Conduct Rescue, Transport and Suppression

Following the collapse of the World Trade Center on September 11, 2001, the majority of the infrastructure surrounding the twin towers was destroyed, including the water distribution system. Fires were still raging in the nearby hi-rise structures. Without a viable water source, firefighters and other rescue personnel were unable to gain entry to the adjacent structures involved with fire to conduct search and rescue operations, or to support the rescue and recovery efforts at the collapse site.

Four fireboats from the FDNY Marine Division responded to the World Trade Center. The fireboat, *John McKean* from Marine Company 1, arrived on the scene before the first tower collapsed. The *McKean* was being used to evacuate civilians who had been trapped in Battery Park south of the towers when the collapse occurred. The ensuing dust and smoke cloud following the collapse resulted in near zero visibility. The people became disoriented and frightened and began running blindly toward the Hudson River. As they reached the bulkhead many jumped onto the deck of the *McKean* that subsequently transported the evacuees across the river to New Jersey. The *McKean* returned to Battery Park and initiated pumping operations. The *McKean* was later joined by the fireboats *Firefighter*, and *Smoke II*. At the time of the initial attack, the fireboat, *Kevin C. Kane*, was out of service undergoing repairs. The crew of the *Kane* quickly placed their boat back in service, and responded to the scene, and joined the other fireboats in fire suppression and rescue operations. The *Kane* was used to evacuate people from lower Manhattan to safety.

The retired fireboat, *John J. Harvey*, also saw action. When the new commercial owners of the *John J. Harvey* heard of the attacks they decided to respond to scene to offer assistance. Over the course of the next three days, three fireboats including the *John J. Harvey* supplied nearly 60,000 gallons of water per minute to land-based fire apparatus, through water manifolds, and supply lines that supplied building standpipe systems. After three days of pumping, the *John J. Harvey* was released, while the remaining fireboats continued to pump for two additional days.

UNITED STATES COAST GUARD FIRE PROTECTION RESPONSIBILITY

It is important that fire departments with marine fire units are informed about the fire protection responsibilities of the U.S. Coast Guard (USCG). The USCG can be a source of support under certain circumstances. It is equally important to have a clear understanding of the jurisdictional issues between the local fire department and the Coast Guard that surround marine incidents. A fire department's jurisdiction may extend beyond the shoreline and out to the municipal line. That jurisdiction may correspond with the county and state lines and go as far as three miles offshore (on oceans) and much farther on lakes or bays.

The following information was extracted from the NFPA Standard 1925 and briefly outlines the U.S. Coast Guard's authority, policy, and contingency plan as they relate to maritime fire and rescue operations. It is extremely important that municipal fire officials have a firm understanding of these policies and procedures.

U.S. COAST GUARD AUTHORITY

Among the provisions of the Ports and Waterways Safety Act of 1972 (PWSA) (33 U.S.C. 1221 et seq.) is an acknowledgment that increased supervision of port operations is necessary to prevent damage to structures in, on, or adjacent to the navigable waters of the U.S., and to reduce the possibility of vessel or cargo loss, or damage to life, property, and the marine environment. This statute, along with the traditional functions and powers of the Coast Guard to render aid and save property [14 U.S.C. 88(b)], is the basis of Coast Guard fire-fighting activities. 42 U.S.C. 1856-1856d provides that an agency charged with providing fire protection for any property of the United States may enter into reciprocal agreements with state and local fire-fighting organizations to provide for mutual aid. This statute further provides that emergency assistance may be rendered in the absence of a reciprocal agreement, when it is determined by the head of that agency to be in the best interest of the United States.

U.S. COAST GUARD POLICY

The Coast Guard has traditionally provided fire-fighting equipment and training to protect its vessels and property. Captains of the Port (COTPs) are also called upon to provide assistance at major fires on board other vessels and waterfront facilities. [NOTE: COTPs are Coast Guard Officers, authorized by Congress [14 U.S.C. 634 (a)] to be designated by the Commandant of the Coast Guard, to facilitate execution of Coast Guard duties prescribed by law]. Although the Coast Guard clearly has an interest in fighting fires involving vessels or waterfront facilities, local authorities are principally responsible for maintaining necessary fire-fighting capabilities in U.S. ports and harbors. The Coast Guard renders assistance as available, based on the level of training and adequacy of equipment (i.e., Coast Guard personnel and equipment). The Commandant intends to maintain this traditional 'assistance as available' posture without conveying the impression that the Coast Guard is prepared to relieve local fire departments of their responsibilities. Paramount in preparing for vessel or waterfront fires is the need to integrate Coast Guard planning and training efforts with those of other responsible agencies, particularly

local fire departments and port authorities. COTPs shall work closely with municipal fire departments, vessel and facility owners and operators, mutual aid groups, and other interested organizations. The COTP shall develop a firefighting contingency plan, which addresses firefighting in each port within the COTP zone. This plan should be organized in a format similar to the federal local pollution plan as required by the National Oil and Hazardous Substances Pollution Contingency Plan (NCP) (40 CFR 300.43).

U. S. COAST GUARD RESOURCES

The Coast Guard's "assistance as available" policy is in keeping with long-standing policies of the Coast Guard and should not be construed as providing less assistance than in the past. The Coast Guard is an important resource available to fire-fighting organizations because of its fire-fighting contingency plans that are developed for each port and their maritime authority within each port area. The contingency plans are vital to the effective coordination of fire-fighting efforts on vessels in port. In this regard, the Coast Guard is, in fact, providing greater assistance than in the past.

Marine Firefighting and Rescue: Staffing, Training and Certification

A central principle in the fire and rescue service has been that firefighters and rescue personnel *do as they practice* when called to the scene of an emergency. Like land-based firefighting, shipboard and marine fire emergencies require unique skills to be mitigated effectively. These skills must be taught, evaluated, and refreshed regularly to ensure quality performance and firefighter safety. Dependence on traditional land-based firefighting skills—which have often been mastered by individuals selected or promoted to serve in marine units—may be inefficient or dangerous in the non land-based environment.

The type of training provided to firefighters assigned to fireboats varies widely by geographical location, robustness of resources, and age of department. Many coastal departments, like the City of San Diego,¹⁴ have developed extensive training programs, internal certification requirements, and in-service refresher sessions to maintain competency levels in their marine units, which usually are comprised of personnel who are assigned exclusively to marine duty. In contrast, smaller jurisdictions may not have the additional personnel or resources to allocate specifically for fireboat operations and training. These departments may use firefighters normally assigned to land-based stations on a per-call basis for marine incidents, or they may cross-staff the

¹⁴The City of San Diego's two fireboats serve a primary response area in Mission Bay and the Pacific Ocean. Crewmembers receive extensive in-service field training, a 40-hour Department of Boating and Waterways marine firefighting course, an annual refresher training program, and in-service drills. While fireboat pilots are not certified by the United States Coast Guard, there are numerous field training programs leading to internal boat operator certifications available to individuals assigned to the fireboats.

fireboat with an engine or truck company. Training for smaller departments often consists of on-the-job orientation supplemented by mentoring by a more experienced firefighter.

No national standard exists outlining exactly how fireboat crew training is to be delivered, nor are there specific licensing or certification requirements for fireboat crew members. However, departments and agencies using fireboats generally recognize that marine-based operations require a different training philosophy than land-based operations. In this section, we discuss the general requirements for an effective training and/or certification program, the various types of fireboat training that currently is used in the United States, and how different staffing scenarios affect training options for fire companies assigned to a fireboat.

General Elements of an Effective Fireboat Training Program

As is the case with any fire department training program, specific students must satisfy certain knowledge and competency requirements, which is also true when it comes to selecting and training personnel to staff a fireboat. Fireboat crew members have different tasks and require individualized training; a fireboat pilot will need to master a set of skills that builds on those required of a deck-based firefighter.

While each jurisdiction will need to train its firefighters on equipment and procedures unique to that location, there are a number of basic topics with which fireboat crewmembers should be familiar, regardless of place of service. These include:

- fireboat command structure (and how it relates to the incident command structure);
- marine terminology, navigation, and general operations;
- common shipboard firefighting equipment and fixed systems;
- shipboard and marine-based fire operations;
- firefighter safety;
- marine firefighting tactics; and
- hazardous materials and cargo.

Fireboat pilots, in addition to mastering these items, need to be trained thoroughly in navigation, engineering, and crew management—and often need additional licensure through the Coast Guard, depending on the type of boat being used.

Many firefighters, when first assigned to a fireboat, have little or no experience working in a marine environment. Some have never set foot on a boat at all. Therefore, regardless of experience, fireboat training should begin with a basic, working orientation to the parts of the boat,

the equipment it carries, the different personnel it takes to run it, and nautical terms used in day-to-day operations. (Plus a rough seas test to determine if they literally, have the stomach for boat operations!) Learning how to identify other vessels is important as well, since marine-based firefighters frequently will come into contact with unknown ships and crews. In the nautical environment, for example, the captain or master of the ship ultimately is responsible for everything that happens to or on the ship. Firefighters must interact closely with this individual in an emergency; the ship's captain can provide critical information regarding the construction features and hazards of the vessel.

Fireboats respond to many types of emergencies and the training provided to crewmembers must accommodate the diversity of incidents. Responding to a building fire on the waterfront may require water supply support operations for land-based apparatus, or the application of a master stream to areas of the building inaccessible to an aerial tower or engine. Responding to a fire on a cargo ship or cruise liner, however, may require a focused interior attack applying tactics never used during land-based operations. In this environment, numerous opportunities exist for firefighters to become trapped or injured if they are not properly equipped or trained. Firefighter safety and survival in the shipboard and marine environments *depend* on thorough, scenario-based training *before* an emergency occurs.

Maintaining and running a fireboat takes time and appropriate staffing to accomplish. Many jurisdictions, recognizing that it takes more staffing than the captain and crew are needed to sustain a fireboat program, have implemented training programs for firefighters who are assigned duties related to fireboat readiness and maintenance, but not the technical aspects of marine firefighting. For example, some cities draw marine firefighters from several different land-based stations when a fireboat call is received. With operations support personnel trained on just that part of the job, a department can use them to prepare the fireboat for the response, while the marine firefighters are driving to the dock where the boat is kept. This practice allows for the best use of resources within the department and decreases the overall response time to marine incidents.

One consistent feature of most fireboat training programs is the training for the fireboat captain or master. Often, this individual is different than the officer assigned to coordinate fire attack. Though not required in all cases—mainly because fireboats vary widely by size—most fireboat captains are certified/licensed through the United States Coast Guard for operation of a vessel up to 100 tons. In some jurisdictions, such as Jacksonville, Florida, *all* crew members are required to be USCG-licensed regardless of what position they are assigned to on the boat.

Generally, it is not cost-efficient to train all fireboat firefighters to the USCG captain level, unless there is a probability (due to shift rotation for example) that they actually are going to drive the boat. Rather, firefighters without these responsibilities are trained to a “crew” or “mate” level, which allows them to perform all of the tasks necessary to help run the boat and perform firefighting duties. This level of training is not nationally standardized like the training for USCG licensure. It is either delivered on-the-job through a mentoring process or as part of a departmental marine division training program lasting from a few weeks to several months. This is type of training program is employed by the New York City Fire Department (FDNY). At FDNY, all fireboat pilots hold a United States Coast Guard harbor pilot’s license. Firefighters assigned to the fireboat are not USCG-licensed but must complete a hands-on training program through the department’s marine division. Marine engineers, licensed at the USCG engineer level, also are assigned to New York’s fireboats.

DESIGNING THE (ALMOST) PERFECT FIREBOAT

Writing the specifications for a fireboat requires extensive research and planning. The propulsion and pumping systems and the wide variety of tools and equipment carried on these vessels can vary depending on the specific class of fireboat. The National Fire Protection Association (NFPA) Standard 1925, Standards for Marine Firefighting Vessels, establishes minimum requirements for marine firefighting vessels. The standard applies to the construction of new vessels and conversion of existing vessels used for marine firefighting, as well as the maintenance and testing of fireboats. There are three basic classifications of fireboat. The basic design and operational characteristics for each specific class of fireboat are illustrated in Table 3.

Table 3. National Fire Protection Association Fireboat Classifications		
<i>Class A Fireboats</i>	<i>Class B Fireboats</i>	<i>Class C Fireboats</i>
Length of vessel, 65 ft. and over	Length of vessel, 40 – 65 ft.	Length of vessel, 20 – 40 ft.
Minimum pump capacity, 5,000 GPM	Minimum pump capacity, 2,500 GPM	Minimum pump capacity, 500 GPM
Minimum net pump pressure 150 psi	Minimum net pump pressure, 150 psi	Minimum net pump pressure, 150 psi
Minimum Number of Pumps, 2	Minimum number of pumps, 1	Minimum number of pumps, 1
Minimum number of generators, 2	Minimum number of generators, 1	Minimum number of generators, 0
Minimum number of monitor pipes, 4	Minimum number of monitors, 2	Minimum number of monitors, 1
Minimum crew, 3	Minimum crew, 2	Minimum crew, 2
Minimum # of hose connection: 6 – 1 ½ connections 10 – 2 ½ connection or larger	Minimum # of hose connections: 4 – 1 ½ connections 8 – 2 ½ connections or larger	Minimum number of hose connections: 1 – 2 ½ connection 2 – 1 ½ connections
Fuel capacity, 8 hours	Fuel capacity, 8 hours	Fuel capacity, 4 hours

Prior to acquiring a new marine firefighting vessel—or when planning an extensive overhaul of an existing marine firefighting vessel—a comprehensive study should be conducted that clearly identifies the specific mission, operational requirements, and the operating environment of the vessel. Some basic issues that should be considered in the study are:

- the geographical size of the area to be covered by the vessel;
- the nature of the waterfront facilities and vessels to be covered;
- the maximum desirable response times;
- the maximum wake permissible;
- the nature of the marine environment in which the vessel will operate, including mutual aid operations;
- anticipated future growth in the service area;

- volume and nature of responses over the past 10 years;
- anticipated volume and nature of responses over the next 10 years;
- requirements necessary to support land-based operations;
- maximum anticipated duration of a mission;
- maximum pump capacity needed based on previous major fire activity;
- hose and equipment requirements based on previous fire activity; and
- time necessary to remain on station based on previous response activity.

The information gleaned from these basic questions should serve as a basis for developing the requirements and specifications for design and construction of a vessel that possesses the capabilities to safely function in the anticipated operating environment. Special attention and consideration should include a detailed review of the following issues:

- crew requirements (maximum and minimum crew size necessary to efficiently operate the fireboat, training requirements, crew facilities);
- the fireboats pumping capacity (taking into consideration current and future maximum volume and pressure requirements);
- firefighting equipment requirements (including personal protective equipment);
- foam requirements (quantity, and type of extinguishing agent);
- open deck requirements (including land base firefighting support, offshore firefighting, marine rescue operations, ems requirements);
- speed requirements (including the maximum desirable response times to public assembly occupancies, high hazard occupancies, and to the most distant point in response district, wake considerations);
- station-standby requirements (anticipated maximum length of time required to remain on-station, fuel requirements, fuel weight restrictions, freshwater requirements); and
- adverse weather capabilities (fog and nighttime operating needs and requirements, maximum sea operating conditions).

The cost of purchasing, staffing and maintaining a fireboat can place such a firefighting asset beyond the economic reach of many fire departments. Out of necessity, some fire departments have developed alternative methods for providing some level of port fire protection. This was the case for the Port of Montreal, Canada. For as long as the port had been in operation there was an agreement between the Canadian Federal Government and the City of Montreal Fire

Department to provide the port with both land-based and marine fire protection services. Since the Port of Montreal experienced such few fires the Montreal Fire Department did not own or operate a fireboat. However, from 1959 to 1992, McAllister Towing and Salvage Incorporated would make the tug-boat *James Battle* (a former Detroit MI, fireboat with a 10,000-GPM capacity) available to the Montreal Fire Department upon request. Unfortunately in 1992 McAllister informed the Montreal Fire Department *the James Battle* would be permanently removed from service and would not be replaced. Although the services of *James Battle* were seldom used, the Port of Montreal still represented a significant fire hazard and there was a need for water-based firefighting capabilities. An innovative solution was found, *The Fire Barge*.¹⁵

The barge provided the fire department with an effective firefighting platform at a fraction of the cost of a new fireboat. Some minor modifications were made to a barge to enable fire apparatus to be loaded and unloaded. The 135' x 35' barge has a payload capacity of 800 tons, well in excess of anything the fire department might require. The standard complement of apparatus transported on the barge includes one 2000-GPM pumper, one 1050-GPM pumper, one 135' aerial ladder, one 90' elevating platform, and a command unit. The standard practice is for the pumper to supply the elevated master streams; if necessary, the pumper's master stream devices can be used as well. The apparatus carried can vary, depending on the fire situation. For example, additional pumpers can be used in place of aerial apparatus.

During the first operational test of the barge, there were concerns that the barge would not be stable enough to be able to support aerial and elevating platforms. However, the apparatus is configured in a certain manner to solve this problem. Special metal plates were welded onto the deck to properly distribute the weight transmitted through the jacks during aerial ladder and elevated platform operations. Pumpers easily draft water through a hard sleeve attached to the side of the barge.

The barge is always available and is kept at one of two designated loading berths where apparatus can be driven on-board. In the event of a call, apparatus from the closest station respond to the barge; at the same time a tug-boat is dispatched and ties up to the barge to transport it to the fire. The *Fire Barge* has proven to be a cost effective way to meet the operational needs and objectives of the fire department. The Port of Montreal spent approximately \$250,000 on the purchase and modifications made to the *Fire Barge*. The *Fire Barge* provides an advantage over fireboats that lack aerial ladder or elevating platform capabilities. The *Fire Barge* provides easy access to any ship in water delivery or rescue operations.

¹⁵ Stronach, Ian, *An Unusual Fire Boat*, Port of Montreal Firehouse, November 1995.

Whenever designing a fireboat, planners should contact other fire departments that have a marine division to study fireboats already in service. Chances are they may have experienced design or operational anomalies that can provide valuable lessons. The services of a professional naval architect should be enlisted to design the fireboat that fits the fire department's specific operational needs and to look out for the department's interests during the fireboats construction and testing phase.