

Fastening Options

Connections can be made using a variety of fastening options. It is critical to specify the proper fastener to ensure the proper performance of the connections in cold-formed steel construction. The most common and widely used connection methods are screw connections and weld connections. Each type of connection method has various advantages and disadvantages. Therefore, we provide data for both types so you can choose your preferred connection method.



Self-Drilling Screws—externally threaded fasteners with the ability to drill their own hole and form, or “tap,” their own internal threads without deforming their thread and without breaking during installation. These screws are high-strength, one-piece fasteners and are used if the connection of multiple thicknesses of 33mil steel or thicker. One of the more

common self-drilling screws is a #10-16 x 5/8 HWH SD, which indicates a #10 diameter shaft, 16 threads per inch, 5/8 length, hex washer head self-drilling screw.

Fillet Welds—used to make lap joints, corner joints and T-joint connections. As the illustration suggests, the fillet weld is roughly triangular in cross-section, although its shape is not always a right triangle or an isosceles triangle. Weld metal is deposited in a corner formed by the fit-up of the two members and penetrates and fuses with the base metal to form the joint.

Flare Welds—used to join rounded or curved pieces.

- A Flare Bevel groove weld is commonly used to join a rounded or curved piece to a flat piece.
- A Flare V groove weld is commonly used to join two rounded or curved parts.

ALLOWABLE SCREW DESIGN VALUES (LBS/SCREW)

Mils (Gauge)	Design thickness (in)	F _y (ksi)	F _u (ksi)	#8 Screw 0.164" Dia, 0.272" Head Pss = 1000 lbs; Pts = 1545 lbs			#10 Screw 0.190" Dia, 0.340" Head Pss = 1400 lbs; Pts = 1936 lbs			#12 Screw 0.216" Dia, 0.340" Head Pss = 2000 lbs; Pts = 2778 lbs			1/4" Screw 0.250" Dia, 0.409" Head Pss = 2600 lbs; Pts = 4060 lbs		
				Tension			Tension			Tension			Tension		
				Shear	Pull-Over	Pull-Out	Shear	Pull-Over	Pull-Out	Shear	Pull-Over	Pull-Out	Shear	Pull-Over	Pull-Out
33 (20g)	0.0346	33	45	164	212	72	177	265	84	188	265	95	203	318	110
43 (18g)	0.0451	33	45	244	276	94	263	345	109	280	345	124	302	415	144
54 (16g)	0.0566	33	45	333	346	118	370	433	137	394	433	156	424	521	180
		50	65	333	500	171	467	625	198	569	625	225	613	752	261
68 (14g)	0.0713	33	45	333	436	149	467	545	173	557	545	196	600	656	227
		50	65	333	515	215	467	645	249	667	788	284	866	948	328
97 (12g)	0.1017	33	45	333	515	213	467	645	246	667	778	280	867	936	324
		50	65	333	515	307	467	645	356	667	926	405	867	1352	468
118 (10g)	0.1242	33	45	333	515	260	467	645	301	667	926	342	867	1143	396
		50	65	333	515	375	467	645	435	667	926	494	867	1353	572

Screw Value Notes:

- 1 Capacities are based on Section J4 of the AISI S100-16 (2020) w/S2-20 Calculations.
- 2 When connecting materials of different steel thickness or tensile strengths, use the lowest values. Tabulated capacities assume two sheets of equal thickness are connected.
- 3 Calculated capacities are based on Allowable Strength Design (ASD) and include appropriate safety factors.
- 4 When multiple fasteners are used, screws are assumed to have a center-to-center spacing of at least 3 times the nominal diameter.
- 5 Screws are assumed to have a center-of-screw to edge-of-steel dimension of at least 1.5 times the nominal diameter of the screw.
- 6 Pullout capacity is based on the lesser of pull-out capacity in sheet closest to screw tip or tension strength of screw.
- 7 Pullover capacity is based on the lesser of pullover capacity for sheet closest to screw header, or tension strength of screw.
- 8 Listed capacities are for pure shear or tension loads only. For combined shear and pullover, see AISI S100 Section J4.5.
- 9 Shear strength for #8, #10, #12, and 1/4" screws shall be greater than or equal to 1000 lbs, 1400 lbs, 2000 lbs, and 2600 lbs respectively.
- 10 Tension strength for #8, #10, #12, and 1/4" screws shall be greater than or equal to 1545 lbs, 1936 lbs, 2778 lbs, and 4060 lbs respectively.

ALLOWABLE WELD VALUES (LBS/IN)

Mils (Gauge)	Design thickness (in)	F _y (ksi)	F _u (ksi)	Weld (1 inch)	
				Fillet	Flare Groove
43 (18)	0.0451	33	45	619	544
		33	45	822	682
54 (16)	0.0566	50	65	1188	985
		33	45	1082	859
68 (14)	0.0713	50	65	1563	1241
		33	45	1269	1226
97 (12)	0.1017	50	65	1269	1402
		33	45	1550	1497
118 (10)	0.1242	50	65	1550	1712

Weld Value Notes:

- 1 Capacities are based on Sections J2.5, and J2.6 of the AISI S100-16 (2020) w/S2-20 Calculations.
- 2 When connecting materials of different steel thickness or tensile strengths, use the lowest values. Tabulated capacities assume two sheets of equal thickness are connected.
- 3 Calculated capacities are based on Allowable Strength Design (ASD) and include appropriate safety factors.
- 4 Weld strengths are given in lbs/in and are based on E60XX electrodes.
- 5 For flare groove welds when t > 0.1", t_w = (5/16)*R when weld filled flush to surface.

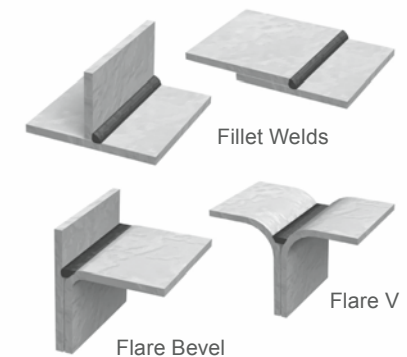

Complies with AISI S100-16 (2020) w/S2-20 • IBC 2024

The technical content of this literature is effective 06/01/24 and supersedes all previous information.