

**Taurisci**



# The End of the Early La Tène Period in Styria: A View to the East

Boris Kavur

**Abstract:** The earliest Celtic burials within the former borders of Styria (today belonging to Austria and Slovenia) can be dated to the end of the La Tène B phase. Inhumations still dominate the cemetery record and male burials are characterised by undamaged swords with decorated scabbards with open-worked chapes. They form a regional group of the first Celtic settlers in this area.

**Keywords:** Early La Tène period, male burials, Hatvan-Boldog type swords.

**Zusammenfassung:** Am Ende von Latène B überwiegen auf Gräberfeldern innerhalb der einstigen Landesgrenzen der Steiermark (heute zu Österreich und Slowenien gehörend) noch Skelettgräber, und Bestattungen von Männern sind durch unbeschädigte Schwerter mit verzierten Scheiden mit durchbrochenen Ortsbändern gekennzeichnet. Sie bilden eine regionale Gruppe der ersten keltischen Ansiedler dieses Gebietes.

**Stichwörter:** Frühlatènezeit, Männergräber, Hatvan-Boldog Schwerttyp.

Due to the specific geography of today's Slovenia and its influences on the settlement dynamics and population movements in the middle of the 4<sup>th</sup> century BC, some newcomers arrived in the area of eastern Slovenia – they were a part of the Celtic communities of central European origin. Their material culture, exhibiting influences from the east and the west, blended with the local traditions to create a mosaic of cultural groups. We can assume that the eastern and central part of Slovenia became more or less Celticised, while in the western part of Slovenia (Inner Carniola, the Karst region and the Soča river basin) only selectively adopted several elements of La Tène material culture; some individuals may have become integrated into the societies as well.

The process of arrival of these newcomers and their appropriation of the territory can be observed in the

archaeological record in Styria on the territory between the Graz Basin in Austria and the Drava River in Slovenia. Several small cemeteries consisting of only a few graves as well as some supposedly isolated burials demonstrate how small groups, coming from the east, penetrated into the territory,<sup>1</sup> occupying first the strategically important positions and later settling the same places occupied in previous centuries. The identity and origin of these small groups, led by the sword-bearers, can be discerned from their attire and their equipment, as well as from female attire. In the same way, we can observe the relatively rapid creation of local identity and economy gravitating around local production centres, which developed their own specific “signature” out of the common Celtic stylistic heritage.

In other words, the material culture becomes a derivation of general Eastern Celtic cultural elements, elements that can be observed in the forms and decoration of weaponry, especially swords. In recent decades, discoveries in western Hungary, southern Austria and eastern Slovenia yielded several Early La Tène swords bearing witness to this initial phase of occupation (Fig. 1). Unfortunately, several of these are still not properly published, but the present examples enable us to include the region in the broader cultural development of Eastern Celtic art.

One of the sites listed above, a stone in the great mosaic of initial Celtic settlement, is the site of Srednica in Zgornja Hajdina near Ptuj in Slovenia, where in 2006 and 2007 a little bit more than 65,000 square meters were excavated. It is located on a Late Pleistocene terrace of the Drava River, in a field south of the Pragersko-Ptuj railway. The oldest occupation dates to the Copper Age, two features could be dated to the Early Bronze Age, a cemetery and a settlement could be dated to the Early Iron Age, and finally a Roman settlement covered all of

---

1. MEGAW, MEGAW 2012, 402, 404, Fig. 4.

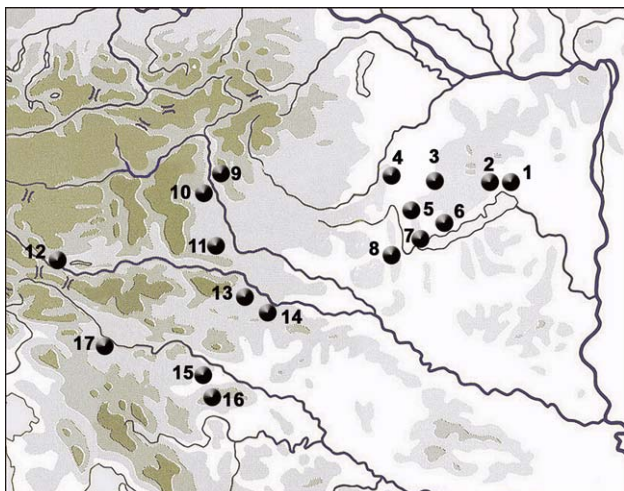

Fig. 1. Sites with Early La Tène type swords in southern Austria, western Hungary and eastern Slovenia. – 1. Litér (type Kosd C). – 2. Jutas (type Kosd C). – 3. Halimba (type Kosd C). – 4. Potypusztá-Csehimindszent (type Kosd C). – 5. Rezi-Rezicséri, Grave 4 (type Kosd D), Grave 66 (type Kosd C). – 6. Tapolca-Szentkút (type Kosd C). – 7. Balatonmagyörök-Kövesmező, grave 1 (type Kosd C). – 8. Magyarszerdahely-Homokidülő, Grave 30 (type Kosd B). – 9. Graz-Laubgasse (type Kosd C). – 10. Lieboch (type Kosd A2). – 11. Kleinklein (type Kosd C). – 12. Villach-Förk (type Kosd C). – 13. Orehova vas, grave 1 (type Kosd C). – 14. Srednica (type Kosd A2). – 15. Mokronog (type Kosd C). – 16. Novo Mesto, Grave 71 (type Kosd B), Grave 466 (type Kosd A1), grave 555 (type Kosd B), Grave 620 (type Kosd A1). – 17. Ljubljana (unknown type) (after LUBŠINA TUŠEK, KAVUR 2011).

it. Archaeological remains were heavily damaged due to intensive modern cultivation.

The Early Iron Age cemetery consisted of 27 small, flattened tumuli with a central grave and a peripheral ditch. Unfortunately, these were completely flattened, and consequently the majority of graves were destroyed. Two inhumations (Graves 4 and 7) and two cremations (Graves 6 and 9) dating to the Late Iron Age were later dug into the peripheral area of the cemetery.<sup>2</sup> The first Celtic settlers obviously selected the former cemetery for their burials and dug Graves 6 and 7 into Tumulus no. 6, Grave 4 into Tumulus no. 4, and Grave 9 into the peripheral area close to the ditch of Tumulus no. 21.

Although very few bones were preserved due to the chemical characteristics of the soil, we could still gather enough details to observe the change in burial rites at this small graveyard. The earliest graves were still inhumations. In the female Graves 4 and 7 parts of the long bones of the deceased were preserved in areas where they were in contact with their bronze ring jewellery. Only

the man in Grave no. 9 was buried in a small square pit, and the presence of a small quantity of charcoal remains indicates that he was cremated with his weapons being placed in his grave intact. These graves yielded a set of grave goods which can help us to place these individuals into a broader context of the end of the Early and beginning of the Middle La Tène.

We can clearly observe that Grave 4 is the oldest, and the female buried therein as the “keeper of old traditions” linking the identity of the group to the cultural traditions of the Eastern Celts.<sup>3</sup> This interpretation is due both to her skeletal remains and to several grave goods and elements of her attire, such as a pottery flask, an amber ring pendant, a bracelet made from twisted wire with a loop, iron torques, and a fragment of another iron hollow metal sheet torques with typically Early La Tène decoration consisting of parallel oblique lines and stamped decoration of circles with a point in the middle. On the other hand, the burial of the sword-bearer in the Grave no. 9 was the herald of the new things to come.

Grave 9, with a circular pit measuring 1 × 0.75 m, was dug into the remains of an older Early Iron Age Tumulus no. 21. The grave goods consisted of a fibula, a knife, a spear point, a pottery bottle, a ceramic bowl and a sword. The fibula and the pottery bottle were placed in the centre of the pit with the bowl turned upside down, while the sword and the spear point were positioned on the western side of the grave.<sup>4</sup>

The most interesting and indicative find in the grave was the decorated scabbard of the Hatvan-Boldog type (Fig. 2).<sup>5</sup> The scabbard, fully fitting the definition of a “hybrid”, is decorated with an eclectic ornamental design that blends all the La Tène stylistic elements from central Europe.<sup>6</sup> A geometric ornamental design on the scabbard is reminiscent of the Early Style filled with post-Waldalgesheim tendrils, organised in an asymmetrical proto-Hungarian Style manner with an added “yin-yang” ornament borrowed from the formal repertoire of the Plastic Style.<sup>7</sup> The top of the ornamental field is decorated with tendrils forming a pseudo-triskele with non-identical arms and side-shots clasped with reinforcement with two lateral clamps and frontal concave discs decorated with floral features elaborated in the Plastic Style. Its decoration is a reflection of the creative potential unleashed with the expansion of the Celtic world at the end of the 4<sup>th</sup> and the beginning of the 3<sup>rd</sup> century BC, when

3. LUBŠINA TUŠEK, KAVUR 2011, 34–39, 48–50.

4. LUBŠINA TUŠEK, KAVUR 2009, 128–130, Fig. 3.

5. LUBŠINA TUŠEK, KAVUR 2009, 130–132.

6. LUBŠINA TUŠEK, KAVUR 2009, 133–138.

7. SZABÓ, PETRES 1992, 58.

2. LUBŠINA TUŠEK, KAVUR 2009. – LUBŠINA TUŠEK, KAVUR 2011.

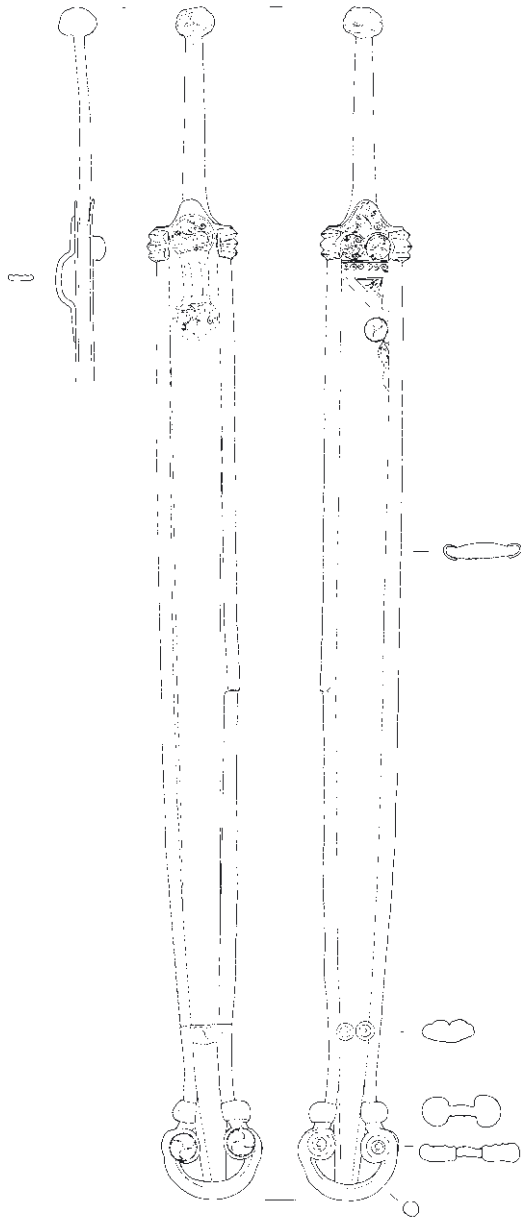

Fig. 2. Sword from Srednica (after LUBŠINA TUŠEK, KAVUR 2009).

the use and reinterpretation of the old artistic traditions became the basis for the creation of the new Middle La Tène styles. Products of these creative centres in eastern Europe were again distributed in the larger area due to trade and the constant journeying of professional warriors and craftsmen.<sup>8</sup>

To put the sword from Srednica into context, we must consider two almost identical scabbards, from Hatvan-Boldog and from Gáva-Katóhalom from Hungary, both exhibiting decorative elements of post-Waldalgesheim

Style (Fig. 3).<sup>9</sup> They have a pseudo-triskele with non-identical arms and side-shots depicted above the frontal reinforcement, which is constructed from two linked discs again linked to two side clamps. The latter are decorated with post-Waldalgesheim tendrils, which also decorate the domed-shaped rosettes fixed to the frontal side of the reinforcement.

A second group of finds that relate to our discussion are the swords from Kosd and Szob from Hungary (Fig. 3).<sup>10</sup> Their frontal reinforcements are constructed from two linked discs again linked to two side clamps. The side clamps are decorated in Plastic Style, which also decorates the domed-shaped rosettes fixed to the frontal side of the reinforcement (unfortunately missing on the scabbard from Kosd).

In several technical details and stylistic elements, the sword recovered from Srednica presents a transitional form between the two groups.<sup>11</sup> Considered in a broader spatial perspective, the swords described above were discovered in central Hungary around the Danube Bend, while only the example from Srednica was located to the west. It differs from the others in the massive reinforcement clamps of the scabbard, which were produced in deep plastic relief and further decorated with hatched lines, and the concave discs decorated with tendrils.

When observing the stylistic development of the decoration, the sword from Srednica clearly presents a form derived from the group produced around the Danube Bend in Hungary. However, several less decorated swords in Styria display the same formal characteristics, suggesting that they were produced locally and possibly that they were the products of a single workshop, most probably somewhere in the region between the today's Graz Basin and the Drava River.

One such sword with an identical form and decoration of the chape-end was discovered in Lieboch in Austria.<sup>12</sup> Although less lavishly decorated, its formal features, size and technical details testify that it was clearly a product of the same workshop. Further identical swords are displayed in the Burgmuseum in Deutschlandsberg in Austria.<sup>13</sup> One of the swords depicted in the exhibition catalogue of the museum has the sides of the mouth of the scabbard enclosed with clasps, clearly deeply profiled and decorated with thin ribs running vertically along the edge. This element could be linked to the Plastic

8. MEGAW, MEGAW 2001, 135.

9. SZABÓ, PETRES 1992, 131, 136, Pls. 13 and 18, Cat. nos. 12 and 18.

10. SZABÓ, PETRES 1992, 188–190, Pls. 70 and 71, Cat. nos. 67 and 68.

11. LUBŠINA TUŠEK, KAVUR 2009, 135–137.

12. HEBERT, LASNIK 1992, 73–75.

13. BERNDT, BERNHARD 1998, 35, 40–41.

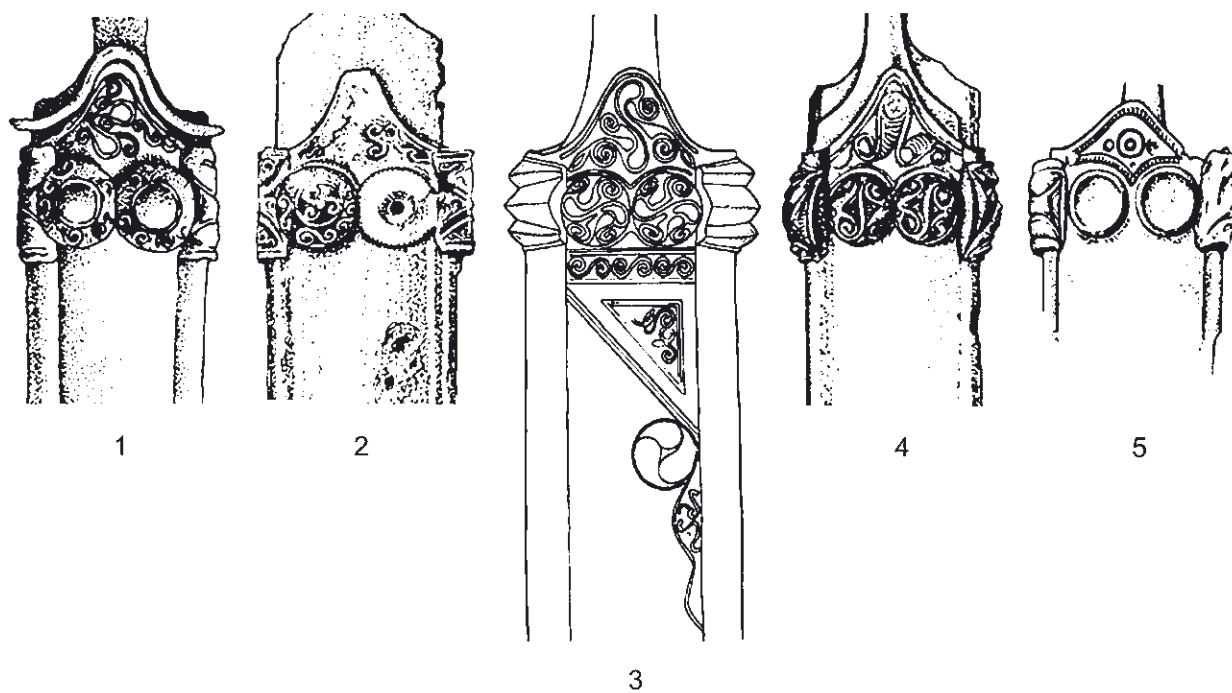

Fig. 3. Swords from Hatvan-Boldog, Gáva-Katóhalom, Srednica, Kosd and Szob (after LUBŠINA TUŠEK, KAVUR 2009).

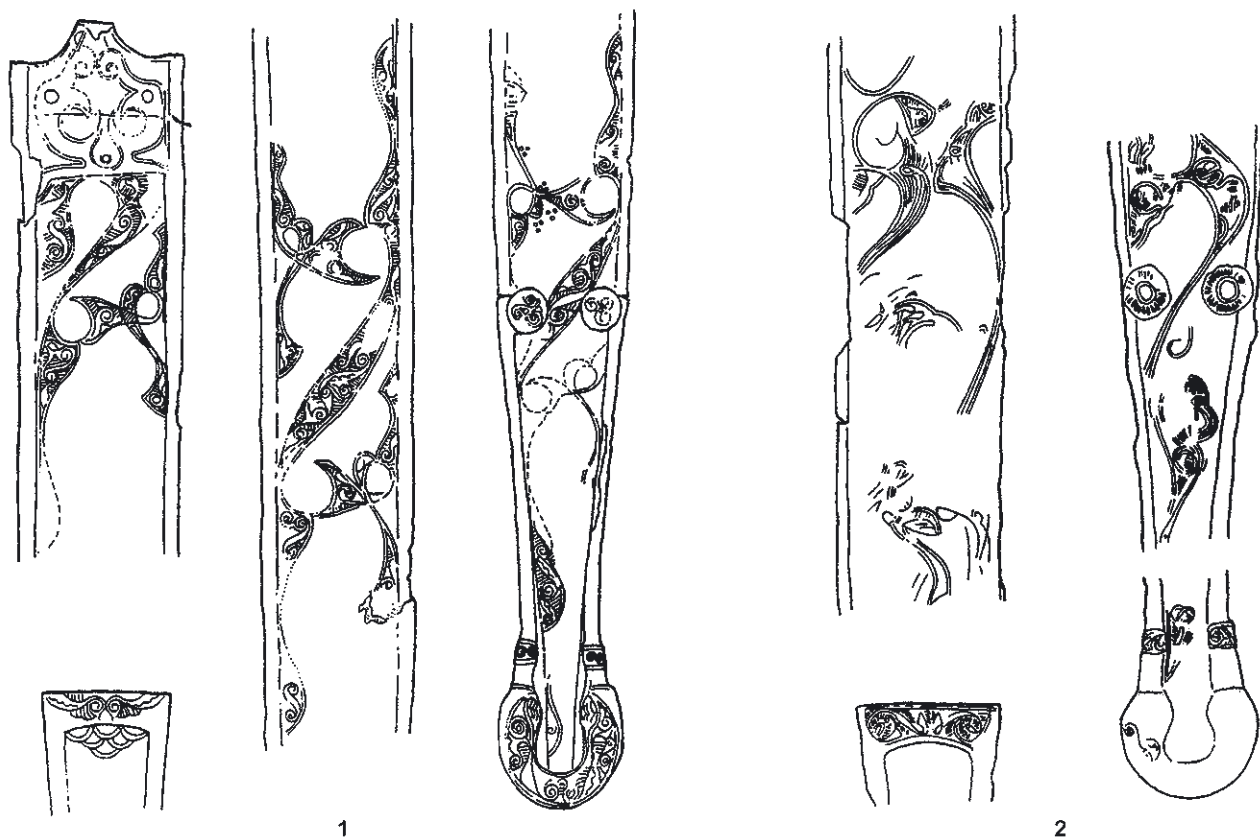

Fig. 4. Swords from Halimba and Kleinklein (after DOBIAT 1996).

Style, as could the two lateral concave discs. Although heavily corroded, they exhibit a pattern of tendrils that is very similar if not identical to the decoration of the scabbard from Srednica. Again, its formal features, size and technical details testify that it was also a product of the same workshop.

The three swords discussed here, all discovered in an area between Graz and Ptuj, clearly demonstrate the connectedness of the area to the most probable place of their stylistic and typological origins. These origins were further elaborated in the development of a local metallurgical tradition, which based on the traditions of the Plastic Style can be observed in the massive clasps and the decoration on the chape ends.

Another exceptional find, a part of the “global” Celtic artistic tradition, decorated in the early “Hungarian Sword Style”, was discovered in the area of the older Early Iron Age cemetery at Burgstallkogel in Kleinklein and preserved in the Burgmuseum in Deutschlandsberg in Austria (Fig. 4).<sup>14</sup>

Unfortunately badly preserved, the sword has a chape-end decorated with intricate tendril patterns of hatched leaves and spirals as well with a “relief line”. The scabbard is decorated with uniaxial free flowing patterns organised in three oblique zones linked with tendrils – all the characteristics of the Hungarian Sword Style. The tight spiral scrolls and half palmette in particular, as well as the decoration of the chape end, exhibit numerous points of comparisons with the sword from Halimba in Hungary (Fig. 4).<sup>15</sup>

In their presentation of the decorated swords from the Carpathian Basin, Miklós Szabó and Éva Petres demonstrated that the manufacture of these swords clearly belongs to the sphere of the Eastern Celtic art, and without presenting the possibility of locating a probable workshop pointed out that there is a major concentration of finds of such decorated swords on the territory to the north of Lake Balaton.<sup>16</sup>

The third exceptional find from the region is the sword discovered in Graz in the former gravel pit in the Laubgasse (Fig. 5). On the badly preserved surface of the scabbard one can recognise a form of decoration present in the whole Celtic world – the punched lozenge decoration in the form of half-palmettes and reversed S's. Although the best comparison can be observed in the same area as presented above on the site of Potypusztá

located to the north of Lake Balaton in Hungary (Fig. 5), the swords with such decoration on the scabbards are distributed across the Celtic world from France to Poland and across Austria, Hungary and Slovakia.<sup>17</sup> Observing the similarity, or actually identity, of the stamps led several authors to the conclusion that it is likely that different swords were produced with the same punch.<sup>18</sup> But when referring to the details of two neighbouring swords it becomes clear that the stamped decoration on the scabbard from Graz was a mirror image of the ones from Potypusztá<sup>19</sup> and that the stamps on later swords had a further decorative element in the form of hatched lines behind the half palmette.<sup>20</sup>

In 1997, László Horváth published a map showing the distribution of La Tène cemeteries in Transdanubia.<sup>21</sup> Burials from the period of LT B were concentrated along the Danube and on the territory between the Neusiedler Lake and Lake Balaton, while the burials from the period LT C occurred around Lake Balaton and to the south. The same opinion was reflected in the map showing the distribution of swords of the Hatvan-Boldog type published by Thomas Stöllner two years later.<sup>22</sup> The territory to the south of Lake Balaton was strangely empty on Stöllner's map. But the picture becomes a little bit clearer if we observe the distribution of the swords of the Kosd A to D types according to Szabó and Petres published a few years earlier.<sup>23</sup> This map offers one of the keys for understanding the process of occupation and further development of the late Early La Tène settlement in the region. It was in the first half of the 4<sup>th</sup> century BC that the Celtic presence was documented in Lower Austria, in southwestern Slovakia and in northern Transdanubia, presumably penetrating from the territory of the Vienna Basin. The sites of Sopron-Bécsidomb and Ménfőcsanak should be counted among the earliest. It was thought that at the end of the century the populations moved towards the area around Lake Balaton,<sup>24</sup> but according to the present finds, the first wave of Celtic populations stopped on a line from south of Graz, towards Deutschlandsberg in Austria and finally ending on the fringes of Pohorje and around the Drava in Slovenia. It is important to mention that the finds from the earliest female graves in Srednica as

14. DOBIAT 1996, 86.

15. MEGAW 1973, 128–129, Fig. 6. – SZABÓ, PETRES 1992, 43, Suppl. 1.

16. SZABÓ, PETRES 1992, 45.

17. MEGAW, MEGAW 2012, 404.

18. LEJARS 1994, 74.

19. KRAMER 1994, 20.

20. FREY 1979, 69, 73, Fig. 6.

21. HORVÁTH 1997, 90, Fig. 8.

22. STÖLLNER 1998, Beilage 3.

23. SZABÓ, PETRES 1992, 81–82, Figs. III and IV.

24. SZABÓ 1992, 21–22.



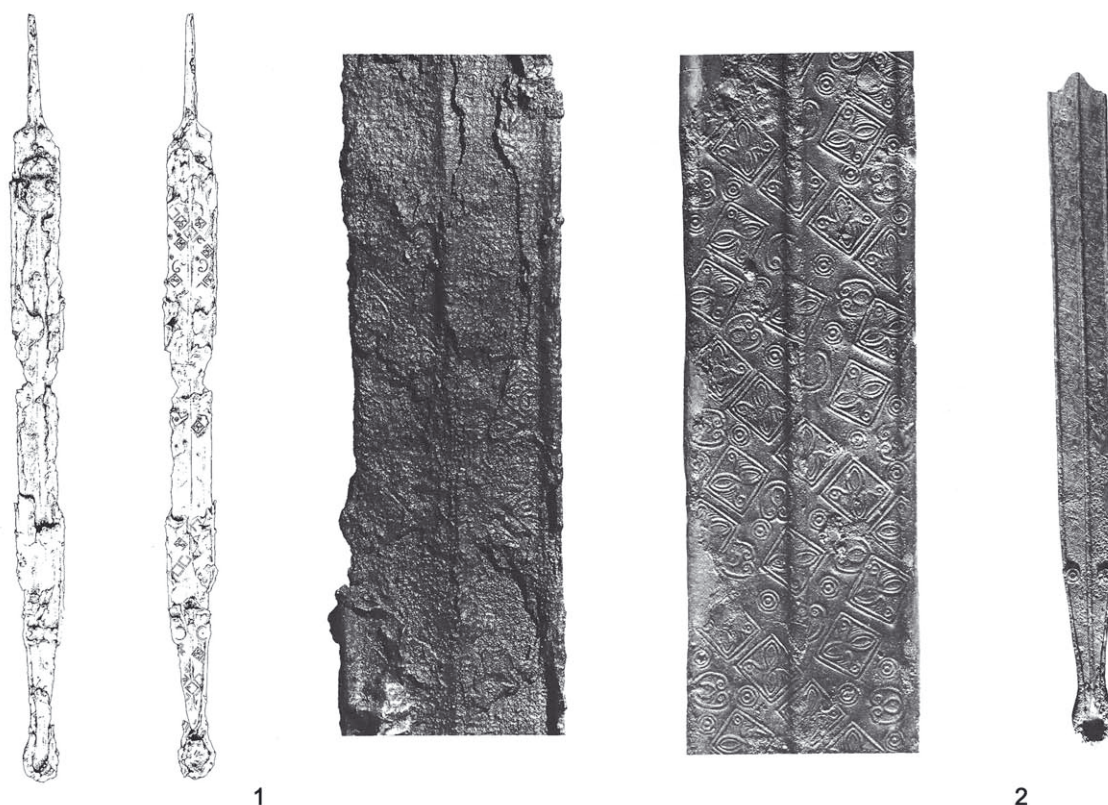

Fig. 5. Swords from Graz-Laubgasse and Potypuszta (after FREY 1979).

well as other finds in southern Transdanubia and further into the Balkan Peninsula demonstrate connection to the centres of Celtic expansion in southern Slovakia.<sup>25</sup> In this initial phase of colonisation only a few inhumation burials are known. They feature the last occurrence of Early La Tène type artefacts – elements of the material culture of the incoming Celts. It might have taken place in the middle of the 4<sup>th</sup> century BC<sup>26</sup> when the territory of today's Styria became integrated into the cultural *koiné* of the Eastern Celts.<sup>27</sup> Considering these three swords with their decorated scabbards, the finds from Srednica, Kleinklein and Graz, we can conclude that in the period of Late LT B and Early LT C, the area of Styria was the western edge of the Eastern Celtic world, which although initially settled by the communities deriving from the territory between southern Slovakia and the Danube Bend, maintained contacts with the Celtic communities to the north of Lake Balaton and further developed several local traditions. Artistic traditions created and further developed in the local production centres maintained

the contacts and the balance but marked the specific cultural development of the Middle La Tène in the region.

#### Acknowledgements

I have to thank to Marija Lubšina Tušek from the Centre for Preventive Archaeology, Institute for the Protection of Cultural Heritage of Slovenia for access to the finds from Srednica and Martina Blečić Kavur for all her help and understanding.

#### References

- BERNDT, BERNHARD 1998  
 S. BERNDT, A. BERNHARD, Die Kelten im südweststeirischen Teil des Königreiches Norikum. Deutschlandsberg 1998.  
 DOBIAT 1996  
 C. DOBIAT, Ein latènezeitliches Kriegergrab am Burgstallkogel bei Kleinklein/Steiermark (LT B2/C)? In: T. STÖLLNER (Ed.), Europa celtica: Untersuchungen zur Hallstatt- und Latènekultur. Veröffentlichungen des Vorgeschichtlichen Seminars Marburg – Sonderband 12, Marburg 1996, 85–93.

25. HORVÁTH 2005, 63. – SZABÓ, TANKO 2006, 330.

26. KAVUR, GUŠTIN 2011, 129–130.

27. SZABÓ 1985, 65.



- FREY 1979  
O.-H. FREY, Ein verziertes La-Tène-Schwert aus Graz, Schild von Steier: Beiträge zur Steirischen Vor- und Frühgeschichte und Münzkunde 15–16/1978–1979, Festschrift Modrijan, 1979, 67–73.
- HEBERT, LASNIK 1992  
B. HEBERT, E. LASNIK, Spuren der Vergangenheit: Archäologische Funde aus der Weststeiermark. Bärnbach 1992.
- HORVÁTH 1997  
L. HORVÁTH, Einige chronologische Fragen des Keltischen Gräberfeldes von Rezi, Zalai Múzeum 8, 1997, 79–90.
- HORVÁTH 2005  
L. HORVÁTH, Grave of a Celtic warrior from Magyarszerdahely (Zala County), Zalai Múzeum 14, 2005, 61–73.
- KAVUR, GUŠTIN 2011  
B. KAVUR, M. GUŠTIN, Contribution to chronology (in: M. GUŠTIN, On the Celtic tribe of Taurisci: local identity and regional contacts in the ancient world). In: M. GUŠTIN, M. JEVTIĆ (Eds.), The Eastern Celts: The Communities between the Alps and the Black Sea. Koper – Belgrade 2011, 129–130.
- KRAMER 1994  
M. KRAMER, Latènefunde der Steiermark. Kleine Schriften aus dem Vorgeschichtlichen Seminar der Philipps-Universität Marburg 43, Marburg 1994.
- LEJARS 1994  
T. LEJARS, Gournay III, Les fourreau d'épée : Le sanctuaire de Gournay-sur-Aronde et l'armement des Celtes de La Tène Moyenne. Archéologie aujourd'hui, Paris 1994.
- LUBŠINA TUŠEK, KAVUR 2009  
M. LUBŠINA TUŠEK, B. KAVUR, A sword between: the Celtic warriors grave from Srednica in north-eastern Slovenia. In: G. TIEFENGRABER, B. KAVUR, A. GASPARI (Eds.), Keltische Studien II: Studies in Celtic Archaeology. Papers in Honour of Mitja Guštin. Protohistoire Européenne 11, Montagnac 2009, 125–142.
- LUBŠINA TUŠEK, KAVUR 2011  
M. LUBŠINA TUŠEK, B. KAVUR, Srednica near Ptuj: a contribution to the beginning of the La Tène period in eastern Slovenia. In: M. GUŠTIN, M. JEVTIĆ (Eds.), The Eastern Celts: The Communities between the Alps and the Black Sea. Koper – Belgrade 2011, 31–50.
- MEGAW 1973  
V. MEGAW, The decorated sword-scabbard of iron from Cernon-sur-Coole (Marne) and Drňa (Slovakia), Hamburger Beiträge zur Archäologie 3/2, 1973, 119–137.
- MEGAW, MEGAW 2001  
R. MEGAW, V. MEGAW, Celtic Art: From its Beginnings to the Book of Kells. Revised and expanded edition, London 2001.
- MEGAW, MEGAW 2012  
J. V. S. MEGAW, M. R. MEGAW, Poles apart? Notes from the fringes of the "Hungarian" sword style. In: P. ANREITER, E. BÁNFFY, L. BARTOSIEWICZ, W. MEID, C. METZNER-NEBELSICK (Eds.), Archaeological, Cultural and Linguistic Heritage. Festschrift for Erzsébet Jerem in Honour of her 70th Birthday, Budapest 2012, 401–414.
- STÖLLNER 1998  
T. STÖLLNER, Grab 102 vom Dürrnberg bei Hallein, Germania 76/1, 1998, 67–176.
- SZABÓ 1985  
M. SZABÓ, Nouvelles vues sur l'art des Celtes Orientaux, Études celtiques 22, 1985, 53–72.
- SZABÓ 1992  
M. SZABÓ, Les Celtes de l'Est : Le seconde âge du fer dans la cuvette des Karpates. Paris 1992.
- SZABÓ, PETRES 1992  
M. SZABÓ, É. F. PETRES, Decorated Weapons of the La Tène Iron Age in the Carpatian Basin. Inventaria praehistorica Hungariae 5, Budapest 1992.
- SZABÓ, TANKÓ 2006  
M. SZABÓ, K. TANKÓ, Nécropole laténienne à Ludas-Varjú-Dúlő, Acta archaeologica Academiae scientiarum Hungaricae 57, 2006, 324–343.

*Izr. prof. dr. Boris Kavur*  
*Univerza na Primorskem*  
*Fakulteta za humanistične študije*  
*Titov trg 5*  
*6000 Koper*  
*Slovenia*  
*boris.kavur@upr.si*



# Late La Tène Settlements in the Vinkovci Region (Eastern Slavonia, Croatia): Centres of Trade and Exchange

Marko Dizdar

**Abstract:** This paper discusses the settlement network of the Scordisci in the area of Vinkovci in the eastern Slavonia region (Croatia) during the Late La Tène period. Excavations at the multi-period prehistoric settlements along the river Bosut as well as many contemporaneous lowland settlements brought to the light large amounts of metal and glass finds. This indicates the existence of a complex settlement network.

**Keywords:** Late La Tène period, settlement, eastern Slavonia, Vinkovci, exchange, fibulae.

**Zusammenfassung:** Hier wird die Frage des Besiedlungsnetzes der Skordisker in der Vinkovci Region in Ostslawonien während der späten Latènezeit diskutiert. Sowohl auf mehrphasigen Siedlungen entlang des Bosut-Flusses als auch in vielen gleichzeitigen Tiefland-Siedlungen wurden große Mengen von Metall- und Glasfunden lokalisiert, die auf die Existenz von komplexen Besiedlungsnetzwerken hinweisen.

**Stichwörter:** Spätlatènezeit, Siedlungen, Ostslawonien, Vinkovci, Austausch, Fibeln.

Our present understanding of the development of the Late La Tène culture in northern Croatia is mostly based on the sites and finds from eastern Slavonia, which confirm that this area formed part of the distribution area of the central European legacy of the Late La Tène culture. In addition to the Late La Tène finds collected since the end of the 19<sup>th</sup> century,<sup>1</sup> a series of trial and rescue excavations were carried out in the 1970s and 1980s on multi-phase prehistoric settlements along the river Bosut in the Vinkovci region (Orolik, Privlaka, Stari Mikanovci, Dirov Brijeg), as well as in Osijek, where the latest layers are dated to the Late Iron Age (Fig. 1). Based on the finds,

1. MAJNARIĆ-PANDŽIĆ 1970.

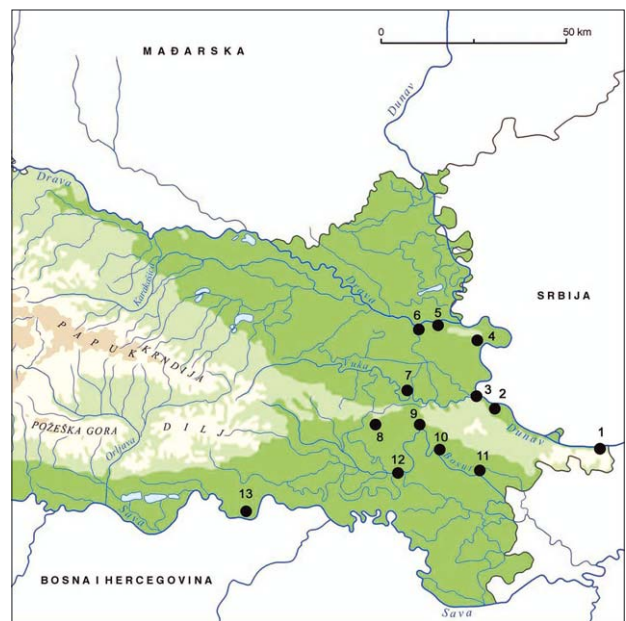

Fig. 1. Fortified and important settlements in eastern Croatia (western Symria and eastern Slavonia). – 1. Ilok. – 2. Sotin. – 3. Vukovar. – 4. Dalj. – 5. Sarvaš. – 6. Osijek. – 7. Markušica. – 8. Stari Mikanovci. – 9. Vinkovci. – 10. Privlaka. – 11. Orolik. – 12. Cerna. – 13. Donja Bebrina.

the fortified settlements were dated to the later phase of the Middle and Late La Tène.<sup>2</sup> In the last twenty years, a number of field surveys in the Vinkovci region have revealed many lowland settlements that can also be dated to the Late La Tène.<sup>3</sup> It is interesting that at the moment, contemporary burials in this area are almost unknown, apart from a report of the chance finds of weaponry (Vinkovci, Otok), which in all probability come from destroyed cremation burials.<sup>4</sup> Recent investigations, in addition to the finds deposited in the Vinkovci Municipi-

2. MAJNARIĆ-PANDŽIĆ 1984. – MAJNARIĆ-PANDŽIĆ 1996a. – ŠIMIĆ 1997. – DIZDAR 2001a.

3. DIZDAR 2001b, 107–108.

4. DIZDAR 2001b, 107–108, Pl. 1/6, 7, 8.

pal Museum, confirmed the suppositions that during the Late La Tène period this region was densely populated by the Scordisci.

During the Late La Tène period, the Scordisci in the Vinkovci region developed a complex settlement network, which included fortified and lowland settlements. Fortified settlements were always placed on strategically favourable locations and communication routes, on natural elevations along the river Bosut and its tributaries, often on tell type settlements formed during earlier prehistoric periods. These settlements were characterised by a fortification system consisting of an earthen rampart and a wide ditch, while inside were houses and other accompanying structures.<sup>5</sup> It can be supposed that in those settlements different workshops existed, especially workshops with pottery kilns, as on Dirov Brijeg in Vinkovci, which produced various types of vessels catering for local needs, but also probably for trade and exchange within a wider region.<sup>6</sup>

At present, based on a number of rescue excavations and field surveys, Vinkovci can be considered as an area with the best known Late La Tène settlement network in eastern Slavonia. There are in fact several Late La Tène sites situated on the right and left banks of the river Bosut, stretching in a continuous line for several kilometres (Fig. 2).<sup>7</sup> It is supposed that the most prominent position was occupied by the fortified settlement on Dirov Brijeg, placed on an elevated position at the confluence of the Nevkoš stream with the Bosut. The results of rescue excavations prior to the 1980s indicate that the Scordisci erected a settlement at the same place where earlier prehistoric settlements had been built.<sup>8</sup> The settlement area close to the Bosut yielded pottery kilns with ceramic finds from the Late La Tène period. Life in the settlement, based on certain chance finds, like a bronze fibula of the Jezerine type,<sup>9</sup> ended at the end of the 1<sup>st</sup> century BC in the period of the Roman conquest of southern Pannonia.<sup>10</sup> The position of the cemetery remains unknown, even though single finds of weaponry from a nearby position point to a possible location.<sup>11</sup>

Close to this central settlement on Dirov Brijeg, traces of contemporary lowland settlements were discovered on low elevations on either side of the Bosut – Ervenica and

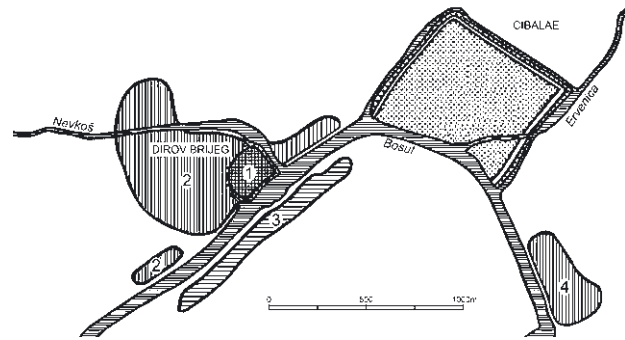

Fig. 2. Late La Tène settlements in Vinkovci and the position of the Roman city *Colonia Aurelia Cibalae*. – 1. Dirov Brijeg. – 2. Krnjaš. – 3. Pjeskana. – 4. Ervenica.

Pjeskana (Fig. 2).<sup>12</sup> During the rescue excavations, traces of settlement infrastructure were revealed, which include different types of structures, such as pits, post holes, etc., although potsherds, as the dominant type of finds, in addition to scarce metal objects, especially fibulae,<sup>13</sup> indicate that the settlements can also be dated to the LT D1.<sup>14</sup> The settlement on Ervenica, based on the pottery finds of characteristic shapes and decoration collected on the western edge of the site, started even earlier, during the earlier phase of the Middle La Tène period (LT C1).<sup>15</sup>

In the early 1990s, during a field survey at Blato in the northern part of Vinkovci (Fig. 3), fragments of pottery vessels and metal and glass finds collected on the surface of the low elevation surrounded by a marshy area point to the existence of a Late La Tène site (Fig. 4). In addition to this, this site yielded finds from other prehistoric periods, as well as from the Roman period. An analysis of the first monograph on the Roman city *Colonia Aurelia Cibalae* from 1902 showed that the site had in fact been discovered during the construction of the railway in 1878. At the same time, fragments of ceramic vessels from the Neolithic and the Late La Tène period were collected at the same place. A trial excavation was promptly carried out and confirmed the existence of the site and the identification of the finds.<sup>16</sup>

After the field surveys in the 1990s and a small trial excavation conducted in 1998 it was difficult to form a conclusion about the original context of the discoveries, although the discovery of small fragments of burnt bones pointed to the presence of a Late La Tène cemetery.

5. MAJNARIĆ-PANDŽIĆ 1984. – DIZDAR 2001a.

6. DIZDAR 2001a.

7. DIMITRIJEVIĆ 1979, 144–146, Fig. 4. – DIZDAR 2001a, 21–27, Figs. 5–8.

8. DIZDAR 1999. – DIZDAR 2001a.

9. DIZDAR 1999, 116, Cat. no. 163.

10. DIZDAR 2001a, 109–110.

11. DIZDAR 2001b, 105.

12. MAJNARIĆ-PANDŽIĆ 1970, 66–67, Fig. 5. – DIMITRIJEVIĆ 1979, 147, Pl. 9. – DIZDAR 2001a, 24–27, Fig. 7. – DIZDAR 2001b, 104–105.

13. MAJNARIĆ-PANDŽIĆ 1970, 66–67, Fig. 5, Pl. XXII/2, 3.

14. DIZDAR 1999. – DIZDAR 2003.

15. DIZDAR 2001a, 97–99, Pls. 1–3.

16. BRUNŠMID 1902, 122–123.



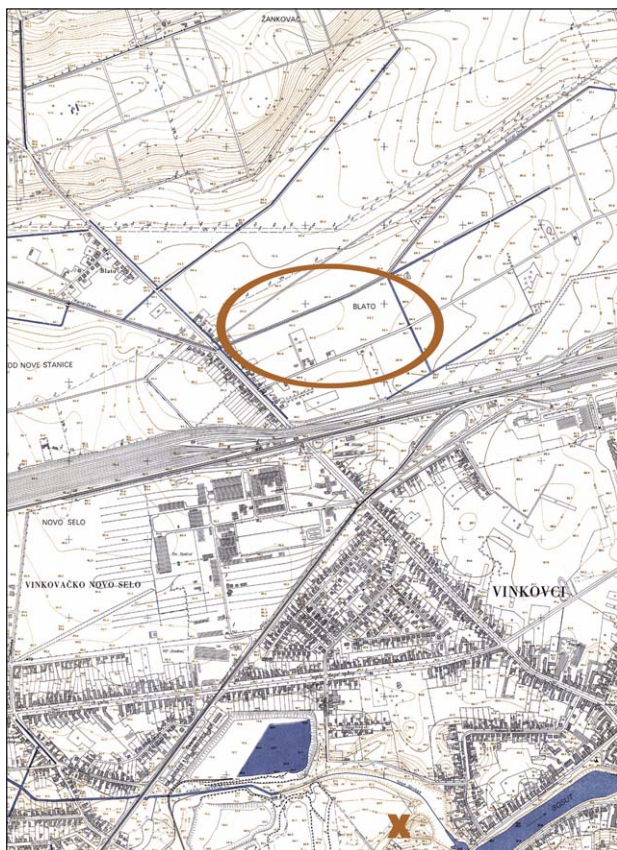

Fig. 3. Locations of the fortified settlement at Dirov Brijeg and the lowland settlement at Blato.

The results of this excavation show that the site has been largely destroyed by deep ploughing and that only the lower parts of features remained preserved.<sup>17</sup> In the following years, the number of collected surface finds rapidly increased, and in 2010 the Vinkovci Municipal Museum and the Institute of Archaeology carried out a trial excavation in the eastern part of the site, excavating a 500 m long trench.<sup>18</sup> During the excavation it was again demonstrated that the site is threatened by ploughing, which was further corroborated by an abundance of finds scattered on the surface of the site. The trench yielded the remains of a lowland settlement with postbuilt houses and pit dwellings separated by shallow ditches. The settlement infrastructure also includes numerous pits and post holes of various shapes, sizes and depths, similar to other contemporary lowland settlements of the Scordisci. During the excavation, a number of potsherds, metal and glass finds were discovered on the surface of the settlement.

17. DIZDAR 1998. – DIZDAR 1999, 47. – DIZDAR 2001b, 104–106.

18. I would like to thank my colleagues Hrvoje Vulić, Maja Krznarić Škrivanko and Anita Rapan Papeša from the Municipal Museum in Vinkovci for the finds and information from the investigation at Blato in Vinkovci.



Fig. 4. Lowland settlement at Blato with the Đakovo-Vinkovci loess plateau in the background.

The abundance and diversity of metal and glass finds suggest that the settlement at Blato was not an ordinary lowland settlement, but that it more likely played a special role in the settlement and communication network and hierarchy of the Scordisci in the area of present-day Vinkovci. The number of metal and glass objects is much higher than in the contemporary fortified settlements in Dirov Brijeg,<sup>19</sup> Osijek<sup>20</sup> or Gomolava,<sup>21</sup> which indicates that we should reconsider the previous model of the settlement network of the Scordisci, in which the most prominent place was reserved for fortified settlements. Those settlements were considered as production “zones” and centres of trade and exchange, and even as political and administrative centres of their respective areas.<sup>22</sup> The discovery of the settlement at Blato points to the existence of a somewhat more complex model of the settlement network of the Scordisci during the Late La Tène period in eastern Slavonia, for which it is important to carry out a detailed analysis of all the collected finds.

The most numerous finds are the fragments of pottery vessels that were mostly made on a potter’s wheel, although hand-made vessels of specific shapes were also recognised (Fig. 5).<sup>23</sup> The other ceramic finds include various forms of weights and spindle whorls. As for the wheel-made forms, two types of bowls predominate: S-profiled bowls with everted rim and bowls with round body and inverted rim. The interior wall of the bowls can be decorated with a grooved wave-line. The most numerous types of pots have a characteristic S-profile, the greatest width in the upper part and a cordon on the shoulder. Some of the pots were decorated with grooved

19. DIZDAR 1999, 47. – DIZDAR 2001b, 104–106, Pls. 4–6.

20. ŠIMIĆ 1997.

21. JOVANOVIĆ, JOVANOVIĆ 1988, 83–85.

22. MAJNARIĆ-PANDŽIĆ 1984. – DIZDAR 2001a.

23. DIZDAR 2001a, 116, Pl. 6.



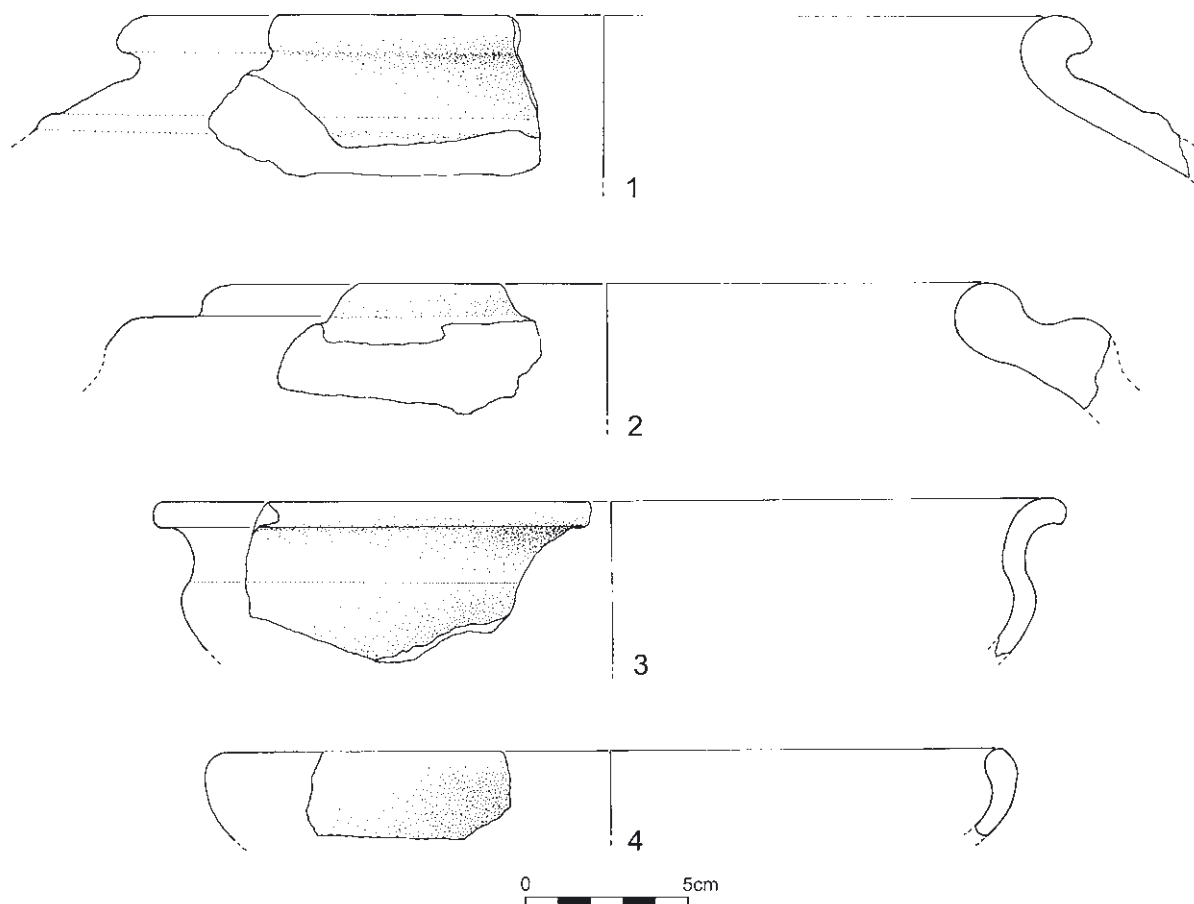

Fig. 5. Fragments of pottery vessels.

wave-lines or vertical lines organised in a metope ornament. One of the characteristic wheel-turned forms is a large storage pots with round body and horizontal, profiled rim (*dolium*). Other wheel-made forms include kantharoi and jugs with profiled strap handles with round body and conical neck. Kantharoi decorated with grooving or burnishing are a form that can be considered as particularly characteristic for the culture of the Scordisci.<sup>24</sup> The so-called situla-shaped pots with dense vertical combed decoration are another characteristic form. Some of these pots have traces of incised decoration. The most common type of hand-made vessels are pots with round body and a wide horizontal groove below the rim of narrow rectangular cross-section. This group also includes undecorated pots with S-profiled body and bowls with a round body.

The preliminary analysis of pottery vessels indicates that the settlement belongs to the Late La Tène, just as did the previously published finds from the fortified

settlement at Dirov Brijeg.<sup>25</sup> All the described shapes, decorative techniques and motifs have their best parallels in other fortified and lowland settlements of the Scordisci in eastern Slavonia and western Syrmia.<sup>26</sup>

For a chronological determination of the settlement and a definition of its position in the communication network, the crucial role is played by the finds of metal and glass objects, which enable us to date the settlement to the Late La Tène, with the beginning probably toward the end of the later phase of the Middle La Tène. Only a single fragment of an Early La Tène bronze fibula of the Dux type was found until now, leaving the problem of the continuity of the settlement into the early phase of the Middle La Tène and then into the Late La Tène still open.

Among the metal finds, pieces of costume and jewelry can be recognised, fragments of bronze vessels and coins, as well as horse gear, while weapons and tools

24. DIZDAR 2001a, 66–69, Pls. 6/1 and 11/4.

25. DIZDAR 2001a, 99–105.

26. MAJNARIĆ-PANĐŽIĆ 1996a. – DALIĆ 1998. – DIZDAR 2001a.

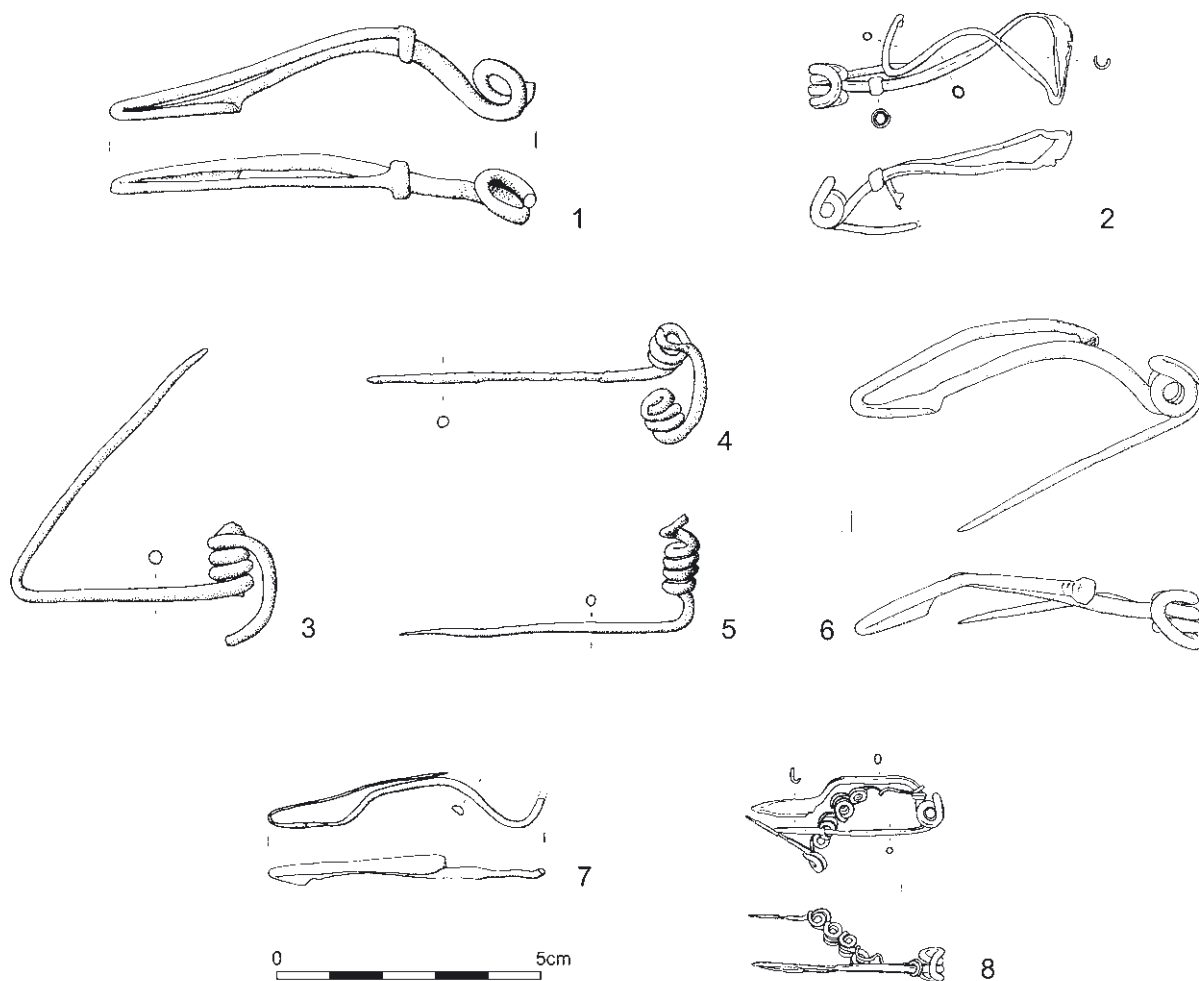

Fig. 6. Bronze wire fibulae of the Middle La Tène construction (1–6), with bent foot in the shape of spear-like plate (7: *Lanzenfibeln*) and with springs on the end of the bent foot (8: *fibules à "crête"*).

are very scarce. The most numerous finds are different types of bronze fibulae, especially plain wire fibulae of Middle La Tène construction with low hemispherical bow of round cross-section and short bent foot (Fig. 6/1–6). Fibulae have a spring with four coils connected with an external chord. This type of fibula is the most common type at the sites of the Scordisci at the beginning of the Late La Tène period. This is corroborated by finds from Vukovar,<sup>27</sup> Sotin,<sup>28</sup> Orolik,<sup>29</sup> Novo Selo,<sup>30</sup> Dalj,<sup>31</sup> Zbjeg,<sup>32</sup>

Gomolava,<sup>33</sup> Saraorci,<sup>34</sup> Dautovac,<sup>35</sup> in the valley of the Mlava River<sup>36</sup> and Rapanović Polje in northeastern Bosnia.<sup>37</sup> Sometimes only the pin and a part of the spring with six coils and external chord are preserved (Fig. 6/3–5), suggesting that the finds from Blato could be ascribed to the late phase of the Middle La Tène (LT C2).

Another variant of plain bronze wire fibulae of Middle La Tène construction consists of fibulae decorated with grooves on the end of the foot, below the attachment with the bow (Fig. 6/6). Parallels are also documented in Late La Tène settlements of the Scordisci, for instance

27. MAJNARIĆ-PANDŽIĆ 1970, Pl. LI/11.

28. ILKIĆ 1999, Pls. XXI/11 and XXII/1.

29. MAJNARIĆ-PANDŽIĆ 1970, 57, Fig. 2. – DIZDAR 2001a, 109, Pl. 2/5 with an internal chord.

30. MAJNARIĆ-PANDŽIĆ 1970, Pl. XXII/5.

31. MAJNARIĆ-PANDŽIĆ 1970, Pls. III/6 and IV/6, 8.

32. MAJNARIĆ-PANDŽIĆ 1970, Pl. XXII/4.

33. JOVANOVIĆ, JOVANOVIĆ 1988, Pl. XLI/8.

34. POPOVIĆ 2001, Pl. 1/17.

35. POPOVIĆ 2003a, Pl. 1/2.

36. STOJČIĆ 2000, 61, Pl. I/46–48.

37. KOSORIĆ 1982, Pl. IV/32.

in Vinkovci-Ervenica,<sup>38</sup> Sotin,<sup>39</sup> Gomolava,<sup>40</sup> Brestovik,<sup>41</sup> Ritopek<sup>42</sup> or in Grave 14 in Pécs-Hőrómű.<sup>43</sup> Very similar are bronze fibulae from the bank of the Danube near Zemun, with hemispherical bows and springs consisting of a larger number of coils connected with external chords.<sup>44</sup>

This is the most numerous group of bronze fibulae, according to parallels from the other sites of the Scordisci and in the wider area of southern Pannonia, suggesting that intensive habitation of the site in Blato started at the beginning of the Late La Tène. It is interesting that the best parallels are known from other settlements of the Scordisci, while contemporary graves, for instance in Karaburma and Rospi Ćuprija, or in destroyed cemeteries, contain other types of Late La Tène fibulae (Karaburma 39, Jarak etc.). Also, for the time being there are no grave assemblages in the territory of the Scordisci and neighbouring areas that could allow a possible subdivision of the LT D1 phase, as has been done in other regions where similar plain wire fibulae are dated to the LT D1a.<sup>45</sup>

Another type of plain wire bronze fibulae is represented by a similar fibula with bent foot in the shape of a narrow triangular or spear-like plate (*Lanzenfibeln*; Fig. 6/7). The fibula has a hemispherical bow of round cross-section and a spring with four coils connected with an external chord. Similar fibulae were defined as group III and appeared at the sites of the Scordisci during the Late La Tène period.<sup>46</sup>

Contemporary with these are bronze fibulae with loops (*fibules à "crête"*) or springs (Pestrup fibula or *Spiralfußfibeln*) (Fig. 6/8) on the end of the bent foot and a spring with four or more coils connected with an external chord. Sometimes the only preserved portion of the foot is the end with two coils around the bow of round cross-section. A fibula with six loops on the end of the foot was discovered in Dautovac.<sup>47</sup> Two similar fibulae with a large number of coils are known from Zemun and Orešac.<sup>48</sup> Bronze fibulae with loops or springs from Blato, like a group of contemporary plain wire fibulae with many parallels at Late La Tène sites of

the Scordisci, suggest that they were produced locally and worn by local inhabitants.

Bronze fibulae of a Middle La Tène construction with different profiles on the bent foot, which, based on the shape and position, can be divided into several types, belong to a different group. The first type is characterised by fibulae with a bow of band cross-section, which thickens towards the spring and with narrow ribbon relief arranged into two groups on the foot – one before the connection with the bow and another at the middle of the foot. The spring was composed of a large number of coils, which were probably connected by an external chord (Fig. 7/1). Based on the shape of the bow and the characteristic relief on the bent foot, the closest parallels are bronze fibulae of the Picugi type, which was dispersed in the southeastern Alpine region and along the eastern Adriatic coast and its hinterland.<sup>49</sup> The fibulae from Blato might be some local Late La Tène variant of the Picugi type, bearing witness to the contacts with areas to the west. Another indicator of influence from this direction is represented by a bronze fibula with a hemispherical bow of band cross section that thickens towards the spring and with four ribbon reliefs at the end of the high foot (Fig. 7/2). The fibula can be ascribed to a variant of the Podzemelj type, which appears in the largest numbers at sites in the Kupa valley and in Carniola.<sup>50</sup>

To the same group of bronze fibulae of Middle La Tène construction with a moulded profile on the bent foot belong fibulae with a hemispherical bow with band cross-section that thickens towards the spring composed of a large number of coils with an external chord. The foot was decorated with a moulded profile arranged into two groups – one of semicircular cross-section before the connection with the bow and another, oval, at the middle of the foot (Fig. 7/3). The closest parallel is known from Dalj,<sup>51</sup> and from unknown sites in Sarmatia<sup>52</sup> and Kostolac.<sup>53</sup> Other parallels are recorded at sites in southern Bosnia and Herzegovina such as Rakitno,<sup>54</sup> Gorica<sup>55</sup> and Vir near Posušje.<sup>56</sup> All the mentioned finds lack any precise stratigraphical data, so the finds from Blato suggest that this type of fibula can be dated to LT D1. A group of similar fibulae from Late La Tène sites in southeastern Europe might be of help for dating. The best known are

38. MAJNARIĆ-PANĐŽIĆ 1970, 66, Fig. 5/4.

39. ILKIĆ 1999, Pl. XXI/9, 10.

40. JOVANOVIĆ, JOVANOVIĆ 1988, Pl. XLI/11, 12.

41. TODOROVIĆ 1971, Pl. LXII/16.

42. TODOROVIĆ 1971, Pl. LXIV/2.

43. MARÁZ 2008, Fig. 12/3.

44. TODOROVIĆ 1971, Pls. LXIII/2, 7, 10 and LXV/10.

45. MIRON 1991. – RIECKHOFF 1995.

46. POPOVIĆ 1994, 57–62, Figs. 5–6.

47. POPOVIĆ 2003a, 147–149, Pl. 1/1.

48. POPOVIĆ 2003a, Fig. 1/4, 5.

49. GUŠTIN 1987, 51–53, Fig. 12. – GUŠTIN 1991, 38–39, Fig. 20.

50. BOŽIĆ 2001, 188–190, Figs. 21–25.

51. MAJNARIĆ-PANĐŽIĆ 1970, Pl. VI/2.

52. TODOROVIĆ 1974, Fig. 97.

53. JACANOVIĆ 1987, Pl. 3.

54. RADIMSKÝ 1893, 176, Fig. 16.

55. RADIMSKÝ 1895, 295, Fig. 29. – TRUHELKA 1902, 20, Fig. 27.

56. ČURČIĆ 1909, 98, Pl. XVIII/14.

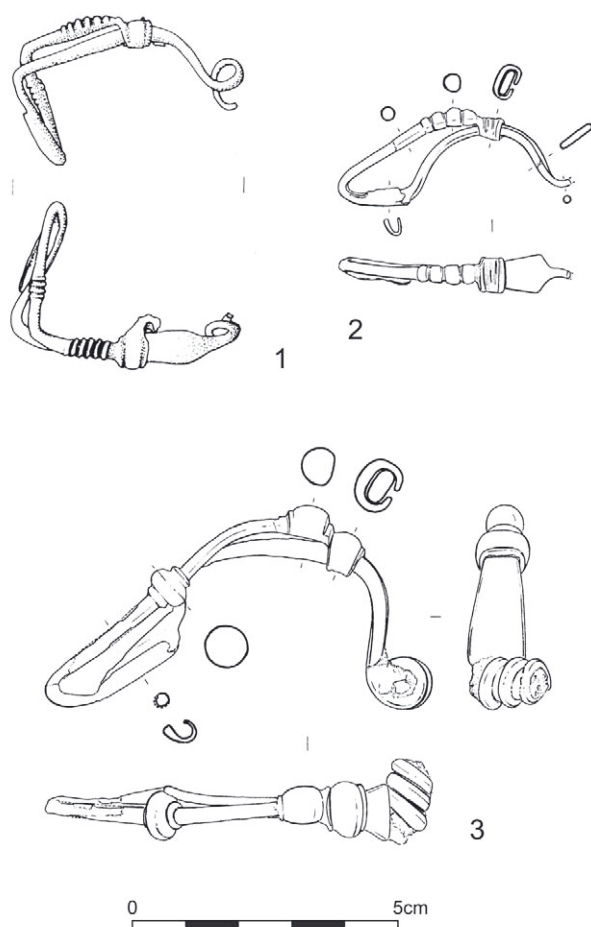

Fig. 7. Bronze fibulae of the Picugi type (1), of the Podzemelj type (2) and of the Rakitno type (3).

bronze or silver fibulae of the Jarak type, dated to LT D1, which have a much wider bow, although the shape of the moulded profile is similar.<sup>57</sup> Contacts between southern Pannonia and the western Balkans are corroborated by the find of a long bronze fibula with short decorated foot from Sotin<sup>58</sup> with the best parallels in finds from Donja Dolina,<sup>59</sup> Breza,<sup>60</sup> Debelo Brdo,<sup>61</sup> Gorica,<sup>62</sup> Vir near Posušje<sup>63</sup> and Gostilj.<sup>64</sup>

Among the metal finds, probably the most prominent are bronze fibulae of the Vinkovci type (Fig. 8/1–3), which

also support the dating of the settlement to LT D1.<sup>65</sup> Fibulae of this type have low triangular or leaf-shaped bows and unperforated rectangular or trapezoidal feet, which are bent in the lower part to function as the catch plate. Fibulae have a spring with four coils connected with an internal or external chord. Three different variants can be recognised based on the decoration of the bow – (1) with undecorated bow; (2) with engraved lines along the edges of the bow; (3) with concentric circle motifs. At the end of the bow there are two, three or two groups of perpendicular grooves. Since Vinkovci type fibulae are particularly numerous at the sites in Vinkovci and neighbourhood (Markušica, Sotin, etc.), it is supposed that they were produced in workshops situated in fortified settlements, which is further supported by the number of variants of this type.<sup>66</sup> Similar fibulae are known from other sites of the Scordisci, like Imrijevc, Gomolava or Zemun.<sup>67</sup> The north westernmost site with finds of this type of fibula is the Oberleiserberg.<sup>68</sup> Vinkovci type fibulae are similar in shape and certain type of decoration to the second group of the Nauheim fibula (Nauheim II.1) with a trapezoidal foot that is most often perforated, although there are fibulae with an unperforated foot. This type is distributed in the northern Adriatic and the southeastern Alpine region, where it is dated to LT D1b.<sup>69</sup>

A very important find is a single find of an iron Nauheim I fibula with elongated triangular bow and frame-shaped foot. The bow is decorated with engraved lines along the edges (Fig. 8/4). This is the first find of this type of fibula in southern Pannonia, pointing to two possible communication routes – one with the northern Adriatic region, and the other, more plausible, with the area north of the Alps.<sup>70</sup>

A small group of cast bronze fibulae was also discovered at Blato. Based on the shape of the bow and perforated foot, a fibula of the Szalacska type (Fig. 9/1)<sup>71</sup> can be recognised, as well as a fibula of the Oberleiserberg type (Fig. 9/2),<sup>72</sup> which additionally strengthens the dating of the settlement to LT D1. These fibulae also confirm the existence of contacts with the neighbouring area of Transdanubia and central Europe. To the same group of cast fibulae belong somewhat younger fibulae of the

57. SLADIĆ 1991. – SLADIĆ 2006. – Hoard Szarad-Regöly: HUNYADY 1944, Pl. 2.

58. MAJNARIĆ-PANDŽIĆ 1970, Pl. XXXVIII/1.

59. TRUHELKA 1904, Pl. XXXVIII/24.

60. PAŠKVALIN 2008, Pl. 16/1.

61. FIALA 1899, 132, Fig. 13.

62. TRUHELKA 1902, 20–21, Figs. 29–30.

63. MARIĆ 1962, 65–66, Pl. II/4, 5. – MARIĆ 1963, 75, Pl. I/17.

64. BASLER 1969, Pls. V/21/6, IX/37/5, 6, X/39/1,2, XI/45/1 and XXI/103/3, 4.

65. DIZDAR 2001a, 110. – DIZDAR 2003. – MAJNARIĆ-PANDŽIĆ 2009.

66. DIZDAR 2003.

67. DIZDAR 2003.

68. KARWOWSKI 2009, Fig. 8. – See also the paper by M. Karwowski in this volume.

69. BOŽIĆ 2008, 50–65.

70. DEMETZ 1999, 78–79, 86.

71. LAZAR 1996, 280, Pl. 1/8.

72. KARWOWSKI, MILITKÝ 2011, 133–135, Figs. 3 and 4.

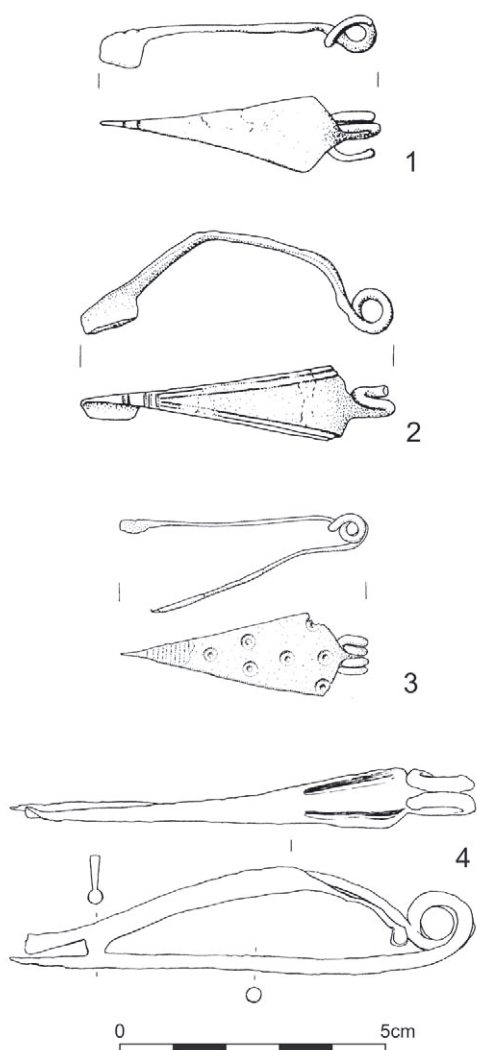

Fig. 8. Bronze fibulae of the Vinkovci type (1–3) and iron fibula of the Nauheim I type (4).

Almgren 65 type (Fig. 9/3),<sup>73</sup> which appears in the second quarter of the 1<sup>st</sup> century BC with peak use during Caesar's time.<sup>74</sup> D. Božič dates it to LT D1b.<sup>75</sup> The latest finds of fibulae from the settlement are bronze fibulae of the Jezerine type (Fig. 10). The bow turns into a spring, which is composed of four coils connected with an internal chord (type IIc).<sup>76</sup> Very interesting are small fibulae of the Jezerine type with analogies in Sotin or Gomolava, which might point to a production in local workshops.<sup>77</sup>

Finds of fragments from glass objects, such as bracelets or beads, are also important for a definition of the chrono-

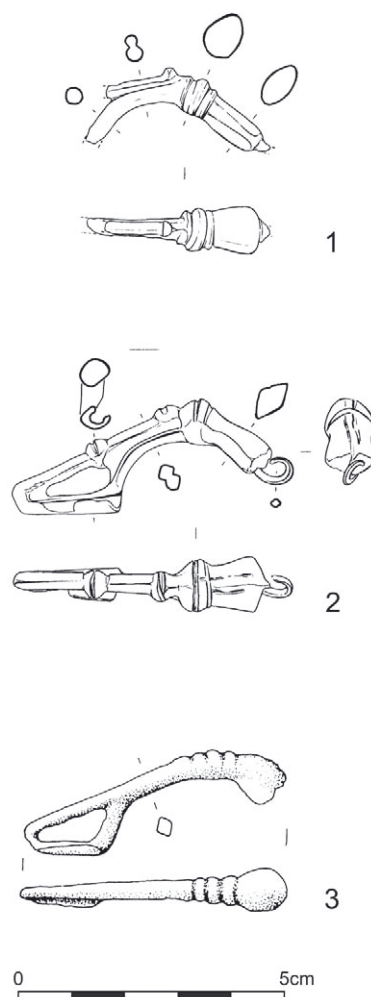

Fig. 9. Bronze fibulae of the Szalacska type (1), of the Oberleiserberg type (2) and of the Almgren 65 type (3).

logical position of the settlement (Fig. 11/1–3). Fragments of a cobalt-blue glass bracelet of type 6b/2 can be dated to the late phase of the Middle La Tène,<sup>78</sup> but the most numerous are fragments of a cobalt-blue bracelet with a D-shaped cross-section of type 3a or series 38, which can be dated to LT D1.<sup>79</sup> Other finds dating to that period are blue glass ring beads with radial decoration<sup>80</sup> and oval blue glass beads decorated with a white-blue circle motif or a horizontal and wavy line.<sup>81</sup>

73. DIZDAR 2001a, Pl. 4/12.

74. DEMETZ 1999, 37.

75. BOŽIČ 2008, 145.

76. DEMETZ 1999, 100–101.

77. DIZDAR 2003.

78. KARWOWSKI 2004, 21–22. – DIZDAR 2006, 84–85.

79. DIZDAR 2006, 76–77.

80. GEBHARD 1989, 177, Pl. 51/772–779. – ZEPEZAUER 1993, 51–52, Pl. 3/7–11. – KARWOWSKI 2004, 44.

81. GEBHARD 1989, Pl. 48/714–718. – ZEPEZAUER 1993, 80, Pl. 10/10–14, 25–28.



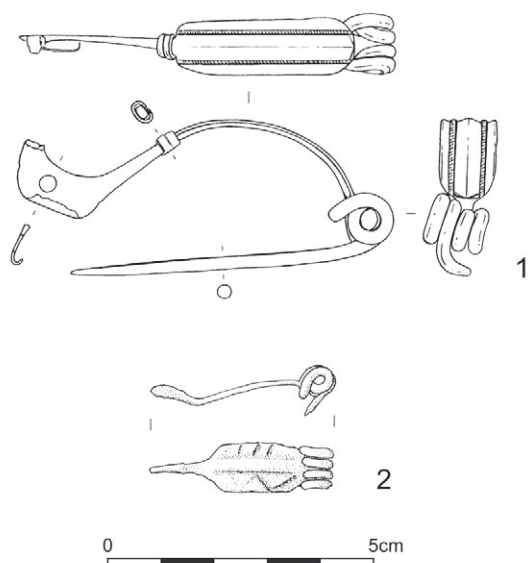

Fig. 10. Bronze fibulae of the Jezerine type.

Fragments of bronze astragal belts (clasps and segments), which are characteristic for the Middle and Late La Tène female costume of the Scordisci, were found on the surface of the site (Fig. 11/4–5).<sup>82</sup> Based on the shape of the segments we can recognise belts of the Osijek and Beograd types,<sup>83</sup> which are also numerous in Sotin<sup>84</sup> or Gradina on Bosut.<sup>85</sup> Interesting are fragments of the narrow segments with undecorated ribs between the more rectangular loops, which belong to the Dunaszekcső type,<sup>86</sup> with analogies in Novi Banovci<sup>87</sup> and Sotin.<sup>88</sup>

The site also yielded bronze pendants of different shapes: foot and basket (Fig. 12), with good analogies at central European sites (Velem Szentvid),<sup>89</sup> but also in the wider area of the La Tène culture, where they are dated from Late Hallstatt to the Late La Tène period.<sup>90</sup> The same direction of the contacts with central European sites is suggested by the finds of bronze pins with curved head and twisted body (Fig. 11/6–7),<sup>91</sup> which are dated to the

82. Božić 1981a, 52–54.

83. Božić 1981b, 47–52, Fig. 3.

84. Ilkić 1999, Pl. XX/3, 5–6, 8–9, 11–12.

85. Popović 2003b, 313, Pl. IV/12–14.

86. Božić 1981a, 50, Fig. 3/17–20.

87. Božić 1981b, Fig. 3/20.

88. Ilkić 1999, Pl. XX/7, 10, 13.

89. MISKE 1908, Pls. XXXVII/65, XXXVIII/37 and XLV/66.

90. FEUGÈRE 1998. – WARNEKE 1999, 135–136. – ČIŽMAŘ 2002, 207–210, Fig. 6–7. – ČIŽMAŘ 2005a, Figs. 2–3. – ČIŽMAŘ 2008, Fig. 1.

91. ZACHAR, REXA 1988, 45, Fig. 14/3.

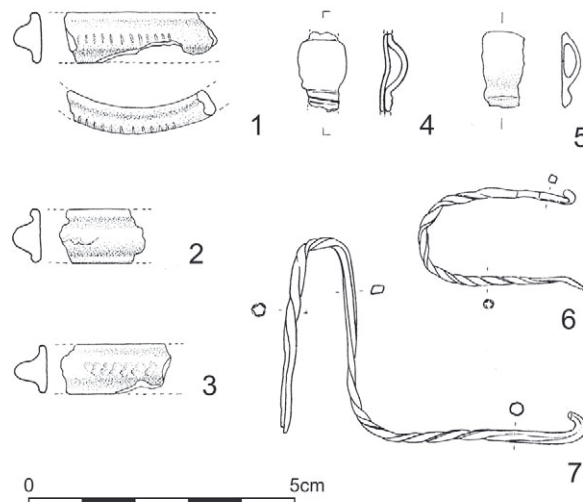

Fig. 11. Fragments of glass bracelets (1–3), fragments of bronze astragal belts (4–5: segments) and bronze pins with curved head and twisted body (6–7).



Fig. 12. Bronze pendants.

Middle-Late La Tène.<sup>92</sup> The oldest finds are from Novo Mesto-Kapiteljska Njiva, where Grave 436 from LT C1 yielded two iron pins with twisted body; one has the head in the shape of a horse, while the other has spherical head.<sup>93</sup> Similar are bronze pins from the Magdalensberg, although they are a little bit smaller, with bent head that is sometimes zoomorphic, while the body is flat or twisted.<sup>94</sup> This direction of contacts is also suggested by the segments of horn chains from Grave 1 in Sotin<sup>95</sup> and a belt clasp from Grave 3 from the same site.<sup>96</sup>

92. ČIŽMAŘ 2010, 383–384, Fig. 1.

93. KRIŽ 2001, 59, 119.

94. GOSTENČNIK 2001, 574–576, Fig. 1. – GOSTENČNIK 2009, 36–37, Fig. 5.

95. MAJNARIĆ-PANDŽIĆ 1972–1973, 64, Pl. 1/8: as a chain belt. – ANDRZEJOWSKI 1991. – ŁUCZKIEWICZ 2010.

96. MAJNARIĆ-PANDŽIĆ 1972–1973, 67, Pl. IV/9. – PESCHECK 1989. – BOCKIUS, ŁUCZKIEWICZ 2004.

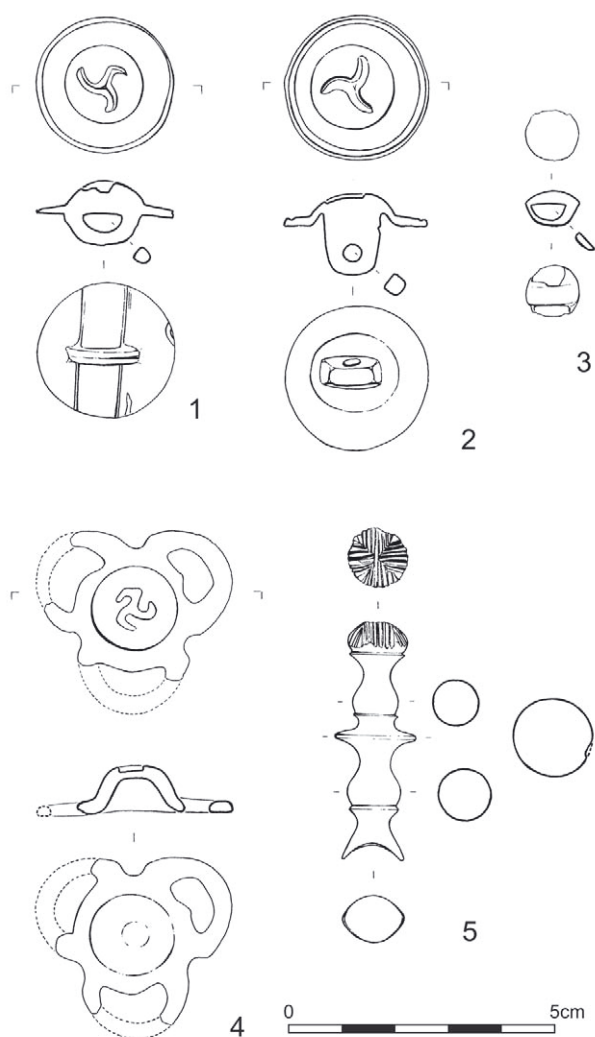

Fig. 13. Bronze finds of horse gear: buttons of various types (1–3), trefoil-shaped strap separators (4) and rein ring of the Hoppstädten type (5).

The area of the settlement at Blato yielded only a few fragments of weapons and tools. The weapons include fragments of spears with elongated blade of rhombic cross section,<sup>97</sup> while the fragments of knife blades could be used as tools.

The settlement yielded numerous finds of horse gear, which cannot be considered as standard inventory for a Scordisci settlement. The most prominent finds are bronze buttons of various types (Fig. 13/1–4), with good analogies in the finds from a Late La Tène sanctuary of the Scordisci in Osijek<sup>98</sup> or Veliki Vetren.<sup>99</sup> There is an abundance of larger buttons that are often decorated on top with a triskele or some other motif and which can

be divided into several variants with regard to decoration and the construction of the lower part through which the belt passed.<sup>100</sup> Other types included bronze trefoil-shaped strap separators, the top of which is decorated with a triskele motif filled with red enamel.<sup>101</sup> The best analogies for buttons and separators are finds from the sanctuary of Scordisci in Osijek and the hoard from Veliki Vetren from LT D1,<sup>102</sup> as well as from sites of the Padea-Panagjurski Kolonii group from the second half of the 2<sup>nd</sup> century BC and the beginning of the 1<sup>st</sup> century BC.<sup>103</sup> Small bronze buttons of spherical shape with a loop at the bottom also belong to the horse gear. A double button from Grave 92 at Karaburma<sup>104</sup> is probably a *pars pro toto*, and together with a zoomorphic buckle can be considered as parts of a horse gear, suggesting that this warrior was a horseman.<sup>105</sup> One of the most important finds is a bronze rein ring of the Hoppstädten type (Fig. 13/5), as this is the south easternmost specimen found so far. This type of horse gear is dated to LT D2, based on a grave from Hoppstädten-Weiersbach,<sup>106</sup> although it can also appear during LT D1, as is the case, for instance, in the Oberleiserberg.<sup>107</sup>

Numerous finds of horse gear from Blato can be associated with a warrior class, which is corroborated by a number of analogous finds documented at Late La Tène sites of the Scordisci, which exhibit the recognisable role the warrior-horsemen played within the community. The warrior elite occupied the most prominent position in the Late La Tène period, and their burials are recognised by the presence of weaponry, horse gear or wagon elements, as well as the rich offerings consisting of ceramic and bronze vessels.<sup>108</sup>

Fragmentary finds of bronze vessels are also associated with the Late La Tène warrior elite of the Scordisci. Bronze vessels belonging to wine-drinking assemblages appeared in cemeteries and settlements of the Scordisci during the LT D1 phase.<sup>109</sup> In eastern Slavonia, bronze

97. DIZDAR 2001a, 113, Pl. 5/1.

98. FILIPOVIĆ 2010. – DIZDAR in press.

99. STOJIC 2003.

100. BOŽIĆ 1993, 139–140, Figs. 2 and 5. – BOŽIĆ 2001, 184, Fig. 5. – ČIŽMÁŘ 2002, 216, Fig. 21.

101. BOŽIĆ 1993, 140–141, Figs. 3 and 6. – BOŽIĆ 2001, 184–185, Fig. 8. – SCHÖNFELDER 2002, 268–269, Fig. 169. – ČIŽMÁŘ 2002, 216, Fig. 20.

102. DIZDAR in press. – STOJIC 2003.

103. ZIRRA 1981. – FREY 1984. – RUSTOIU, SIRBU, FERENCZ 2001–2002, 113–114, Fig. 8. – ŁUCZKIEWICZ, SCHÖNFELDER 2011.

104. TODORVIĆ 1972, Pl. XXIX/20.

105. RUSTOIU 2005, 30, Fig. 2.

106. SCHÖNFELDER 2002, 239–240, Fig. 149.

107. KARWOWSKI 2009, Fig. 6.

108. EGRI, RUSTOIU 2008. – DIZDAR 2012.

109. POPOVIĆ 1992. – DIZDAR, RADMAN-LIVAJA 2004. – DIZDAR, TONC 2014.

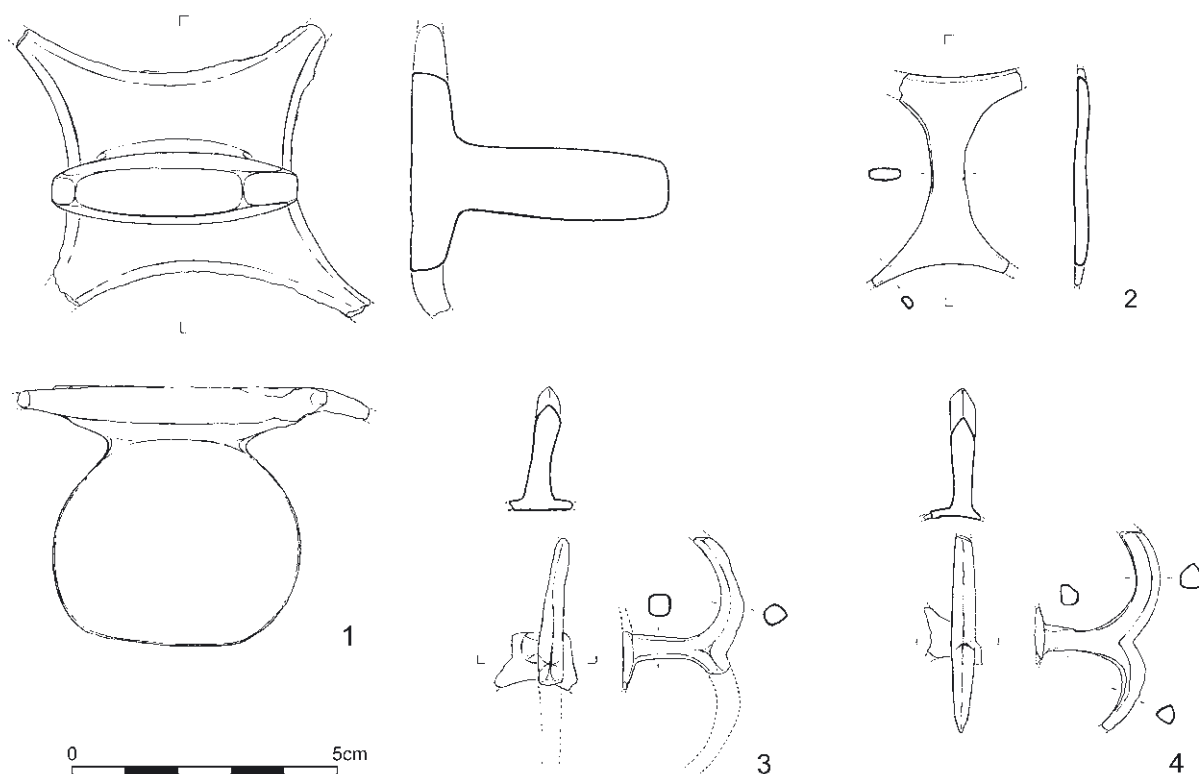

Fig. 14. Fragments of bronze vessels (strainers and a tripod).

vessels were found only at the most prominent sites like Dalj, Vinkovci or Orolik,<sup>110</sup> while in Sotin, the cremation graves discovered at the beginning of the 20<sup>th</sup> century yielded weapons and imported bronze vessels.<sup>111</sup>

Surface finds from the settlement in Blato included fragments of strainers, pans, ladles and a tripod (Fig. 14). The most numerous are handles of bronze strainers (*doigtiers* and *pouciers*). It is supposed that they were produced in Italic or Campanian workshops, but due to their wide distribution it is not out of the question that they were also being produced in Celtic settlements.<sup>112</sup> Further, a bronze handle of a strainer (*doigtier*) was found in Dalj<sup>113</sup> and some other sites of the Scordisci,<sup>114</sup> where the most frequent are *simpula* (ladles) of the Pescate type.<sup>115</sup> Their cast handle is divided into two or three segments and ends in a small stylised animal head. A receptacle was found

in the fortified settlement of Dirov Brijeg,<sup>116</sup> a handle of a *simpulum* of type A was found in Grave I in Sotin,<sup>117</sup> while the fortified settlement Gradina in Orolik yielded a fragment of a handle.<sup>118</sup> *Simpula* were also found in graves at Karaburma,<sup>119</sup> in Grave 1 in Ajmana and Grave 18 in Konopište.<sup>120</sup> All those graves can be dated to the Beograd 3a phase (LT D1),<sup>121</sup> with possible production in Campanian and Etrurian workshops.<sup>122</sup> A unique find is a foot of a tripod of the Tassinari S1100 type,<sup>123</sup> very similar to a find in Grave 113 at Karaburma.<sup>124</sup>

Bronze vessels, as part of *symposium* sets during feasts, were found together with ceramic vessels of local origin in graves of prominent warriors of the Scordisci, kantharoi in particular. They could have been acquired by

110. DIZDAR, RADMAN-LIVAJA 2004.

111. MAJNARIĆ-PANDŽIĆ 1972–1973. – MAJNARIĆ-PANDŽIĆ 1996b.

112. GUILLAUMET 1977, 238–245. – GUILLAUMET 1991, 92–93.

113. DIZDAR, RADMAN-LIVAJA 2004, 50, Pl. 2/2.

114. POPOVIĆ 1992, 61–62.

115. POPOVIĆ 1992, 65.

116. DIZDAR, RADMAN-LIVAJA 2004, Pl. 2/1.

117. MAJNARIĆ-PANDŽIĆ 1972–1973, 63, Pl. 2/1c. – DIZDAR, RADMAN-LIVAJA 2004, Pl. 2/5.

118. DIZDAR 2001a, 115, Pl. 7/8.

119. TODOROVIĆ 1972.

120. POPOVIĆ 1992, 64–66.

121. BOŽIĆ 1981a, 319–321.

122. CASTOLDI, FEUGÈRE 1991, 67–68. – CASTOLDI 2003, 212.

123. BOŽIĆ 2002, 419–422.

124. TODOROVIĆ 1972, Pl. XXXIV/4.

the local elites by means of trade controlled by warrior elite, or as gifts to prominent members of the community. According to Strabo (4.6.10; 5.1.8; 7.5.2), bronze vessels were arriving with wine and olive oil from northern Italy and were traded with the tribes settled along the Danube (the Scordisci) for cattle, slaves and leather. Those vessels arrived via a caravan route leading from Aquileia to *Nauportus* (Vrhnika), where the goods were loaded onto ships and transported by the Ljubljanica and Sava rivers through *Segestica* all the way to the Danube region.<sup>125</sup>

Intensive trade and exchange contacts have also been corroborated by the finds of various bronze and silver coins collected on the surface of the settlement in Blato. It is possible to recognise coins that can be attributed to the different emissions of the Scordisci, mostly of the Sarmian type.<sup>126</sup> Drachms of the Greek cities of Apollonia and Dyrrhachium are particularly important for understanding chronology and interactions. These probably arrived in the Danubian region from the beginning of the 1<sup>st</sup> century BC via several possible directions from the eastern Adriatic coast. This is supported by the hoards from Dalj and Vukovar (one of the hoards from Vukovar also contained Roman Republican denarii minted between 111 and 79 BC).<sup>127</sup> The suggestion that the appearance of the drachms of Apollonia and Dyrrhachium in southern Pannonia should be dated not earlier than the mid-1<sup>st</sup> century BC<sup>128</sup> is partly refuted by the finds from Blato, where the dominant finds are those from the LT D1 phase, while finds from LT D2 are scarce. However, a very interesting theory links the appearance of those coins in large numbers in southern Pannonia with possible mercenary activities of the Scordisci during the 1<sup>st</sup> century BC.<sup>129</sup> On the other hand, a single find of a gold stater of the Vindelician type from an unknown find-spot in Vinkovci confirms the existence of contacts between eastern Slavonia and the area north of the Danube.<sup>130</sup>

The settlement network of the Scordisci in Vinkovci, with a number of other sites in the vicinity, indicates a densely populated area of eastern Slavonia during the Late La Tène period, when the inhabitants of those settlements played an important role in the trade and exchange network. In addition, the increasing number of many different categories of finds bears witness to important social and economic transformations that started occurring

during the mid of the 2<sup>nd</sup> century BC which correspond with the appearance of fortified settlements.

A preliminary analysis of the finds from Blato and their chronological classification make it possible to date the settlement from the later phase of the Middle La Tène (LT C2) to the end of the Late La Tène LT D2 (Beograd 3b). However, settlement activity was most intensive during the second half of the 2<sup>nd</sup> century and the beginning of the 1<sup>st</sup> century BC (LT D1 or Beograd 3a). There is only slight evidence for continuity into LT D2 based on the metal finds, when the settlement probably lost its previous prominent position and its contacts with other, more distant regions. The same decline in imported prestige goods is also visible in other neighbouring regions.

In the light of the discovery of numerous fragments of fibulae, coins and horse gear, Blato can be considered as an atypical lowland settlement without analogies at present in the territory of the Scordisci. It is more likely that the finds can be interpreted as connected with certain intensive commercial and industrial activities like somewhat older settlements in central Europe, such as Němčice or Roseldorf.<sup>131</sup> This is a completely new idea contrasting with the previous understanding of the Late La Tène settlement network of the Scordisci, in which the central position in trade and exchange, based on the previously collected finds, is occupied by the fortified settlements like Gomolava, Privlaka and others.<sup>132</sup> Obviously, these fortified settlements played a prominent role in the settlement network of the Scordisci, but the existence of contemporary lowland settlements like Blato, with a large number of finds from distant regions, is a confirmation that this network was even more complex.

Based on the collected finds, the settlement in Blato participated in the exchange and trade network (Fig. 15) with northern Italy (bronze vessels, Almgren 65 fibula), the southeastern Alpine region (Picugi, Podzemelj type fibula), central Europe (Szalacska, Oberleis, Nauheim I fibula, pendants, horse gear, bronze pins, glass finds, stater) and the southern Adriatic coast (Rakitno fibula, drachms). It is interesting that contacts with the Lower Danube area, especially with the Dacians, still cannot be well recognised, although the existence of some contacts is confirmed by the finds of plastically decorated bowls from the settlements of Lijeva Bara in Vukovar and Gomolava,<sup>133</sup> as well as by certain other categories of

125. DIZDAR, RADMAN-LIVAJA 2004.

126. POPOVIĆ 1987.

127. POPOVIĆ 1978, 18–21. – POPOVIĆ 1987, 102–104. – TORBAGYI 1993.

128. UJES-MORGAN 2012, 373.

129. UJES-MORGAN 2012, 374–375.

130. MAJNARIĆ-PANDŽIĆ 1997.

131. SALAČ 2011.

132. MAJNARIĆ-PANDŽIĆ 1984. – JOVANOVIĆ, JOVANOVIĆ 1988. – DIZDAR 2001a.

133. GABLER 2005, 157.



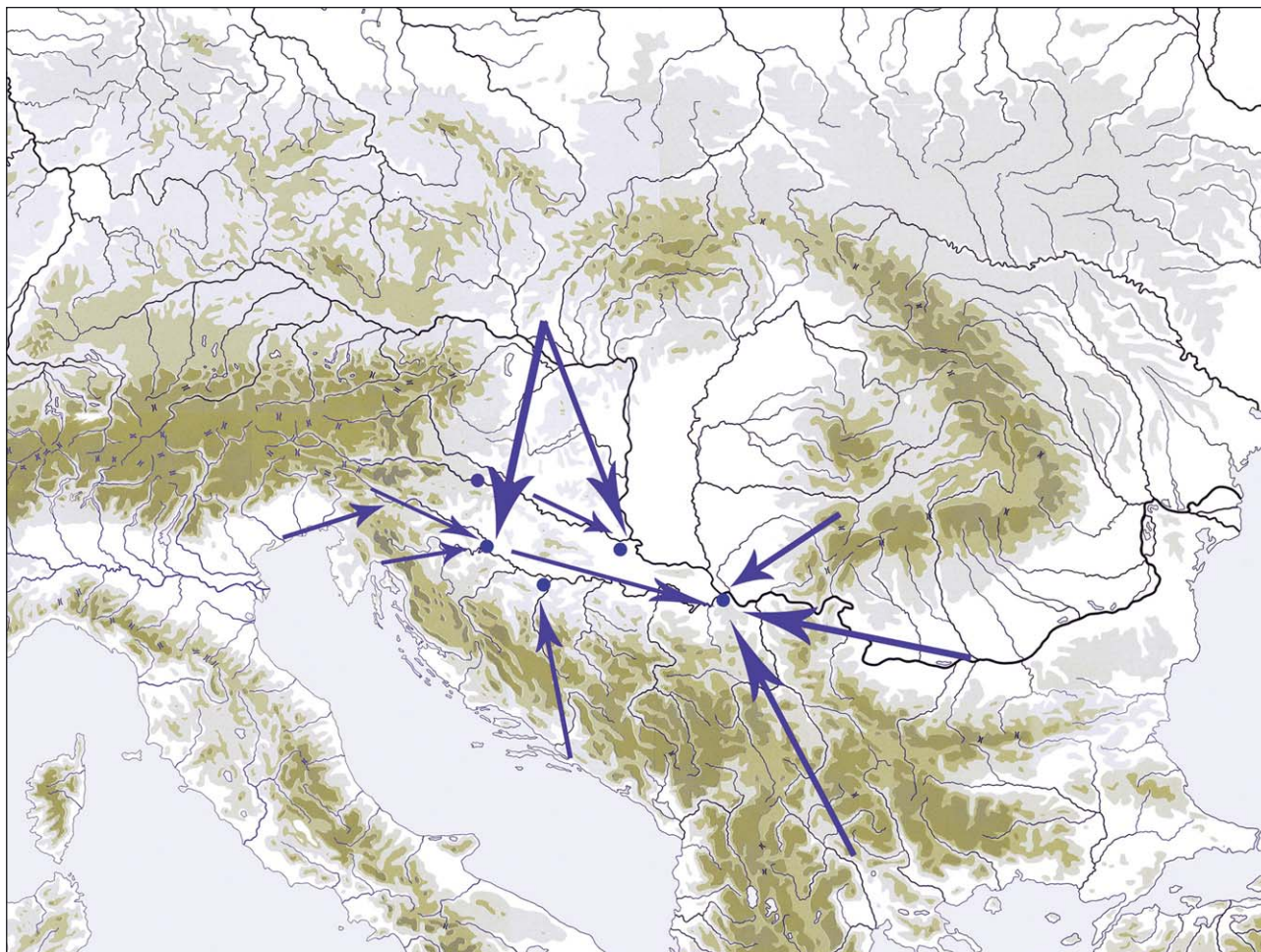

Fig. 15. Settlement in Blato participated in the exchange and trade network with northern Italy, the southeastern Alpine region, central Europe, the southern Adriatic coast and the Lower Danube area.

finds.<sup>134</sup> Many of the finds from Blato that have been mentioned as imports are a good example of contacts with distant regions during the Late La Tène period. Testimony to contacts in the opposite direction is provided by a Vinkovci type fibula from the Oberleiserberg<sup>135</sup> or by certain other finds from Slovakian and Moravian sites, which are considered as a legacy of the Scordisci (fragments of astragal belts, kantharoi).<sup>136</sup> Those contacts can already be observed from the Early and Middle La Tène, as corroborated by finds of glass amphora beads in central Europe,<sup>137</sup> or spropelite rings and glass bracelets in eastern Slavonian and Symian sites of the Scordisci (Osijek, Ilok, Gomolava).<sup>138</sup>

134. MAJNARIĆ-PANĐIĆ 2008.

135. KARWOWSKI 2009, 118, Fig. 8. – See also the paper by M. Karwowski in this volume.

136. ČIZMÁŘ 2005a. – ČIZMÁŘ 2005b.

137. POPOVIĆ 1997. – SCHÖNFELDER 2007. – RUSTOIU 2011.

138. VENCLOVÁ 2002.

In addition to prestigious objects, such as bronze vessels and horse gear intended for the elites, dress accessories and jewellery items were owned by a wide array of social classes, and can perhaps be considered as evidence of the movement of individuals and small groups (merchants), while the numerous finds of Vinkovci type fibulae, used at Scordisci sites as a substitute for the group of fibulae of the Nauheim II type, might provide evidence of the possible transfer of ideas.

For a more comprehensive understanding of the site and collected finds it is necessary to undertake trial excavations on a larger scale that would provide the basis for an explanation of these exceptional and hitherto undocumented finds in the territory of the Scordisci in southern Pannonia.



## References

- ANDRZEJOWSKI 1991  
 J. ANDRZEJOWSKI, Okucia rogów do picia z młodszego okresu przedrzymskiego i okresu wpływów rzymskich w Europie środkowej i północnej (próba klasyfikacji i analizy chronologiczno-terytorialnej), *Materiały Starożytne i Wczesnośredniowieczne* 6, 1991, 7–120.
- BASLER 1969  
 Đ. BASLER, Nekropola na Velim ledinama u Gostilju (Donja Zeta), *Glasnik Zemaljskog muzeja Bosne i Hercegovine u Sarajevu: Arheologija* 24, 1969, 5–107.
- BOCKIUS, ŁUCZKIEWICZ 2004  
 R. BOCKIUS, P. ŁUCZKIEWICZ, Kelten und Germanen im 2.–1. Jahrhundert vor Christus, *Archäologische Bausteine zu einer historischen Frage. Monographien des Römisch-Germanischen Zentralmuseums Mainz* 58, Mainz 2004.
- BOŽIČ 1981a  
 D. BOŽIČ, Relativna kronologija mlajše železne dobi v jugoslovenskem Podonavju, *Arheološki vestnik* 32, 1981, 315–347.
- BOŽIČ 1981b  
 D. BOŽIČ, Kasnolatenski astragalni pojasevi tipa Beograd, *Starinar* 32, 1981, 47–56.
- BOŽIČ 1993  
 D. BOŽIČ, Slovenija in srednja Evropa v poznolatenskem obdobju, *Arheološki vestnik* 44, 1993, 137–152.
- BOŽIČ 2001  
 D. BOŽIČ, Ljudje ob Krki in Kolpi v latenski dobi, *Arheološki vestnik* 52, 2001, 181–198.
- BOŽIČ 2002  
 D. BOŽIČ, Il vasellame bronzeo romano: grandi bacili e piccoli mestoli-colini. In: A. GIUMLIA-MAIR (Ed.), *I bronzi antichi: Produzione e tecnologia. Atti del XV Congresso Internazionale sui Bronzi Antichi organizzato dall'Università di Udine, sede di Gorizia, Grado-Aquileia, 22-26 maggio 2001. Monographies Instrumentum* 21, Montagnac 2002, 419–428.
- BOŽIČ 2008  
 D. BOŽIČ, Poznolatensko-rimsko grobišče v Novem mestu: Ljubljanska cesta in Okrajno glavarstvo. *Katalogi in Monografije* 39, Ljubljana 2008.
- BRUNŠMID 1902  
 J. BRUNŠMID, Colonia Aurelia Cibalae, *Vjesnik Hrvatskoga Arheološkoga Društva NS* 6, 1902, 117–166.
- CASTOLDI 2003  
 M. CASTOLDI, I recipienti di bronzo. In: M. FORTUNATI, L. PAGANI, R. POGGIANI KELLER (Eds.), *Verdello dalle origini all'altomedioevo: ricerche archeologiche e storiche. Verdello* 2003, 209–216.
- CASTOLDI, FEUGÈRE 1991  
 M. CASTOLDI, M. FEUGÈRE, Les simpulums. In: M. FEUGÈRE, C. ROLLEY, *La vaisselle tardo-républicaine en bronze. Dijon* 1991, 61–88.
- ČIŽMÁŘ 2002  
 M. ČIŽMÁŘ, Laténský depot ze Ptení k poznání kontaktů našeho území s jihem, *Památky archeologické* 93/2, 2002, 194–225.
- ČIŽMÁŘ 2005a  
 M. ČIŽMÁŘ, Nové doklady jižních vlivů v době laténské na Moravě. In: E. STUDENÍKOVÁ (Ed.), *Južné uplyvy a ich odraz v kultúrnom vývoji mlašieho praveku na strednom Dunaji. Zborník referátov z konferencie z 9. novembra 2004 v Bratislave. Studia Archaeologica et Mediaevalia* 7, Bratislava 2005, 99–105.
- ČIŽMÁŘ 2005b  
 M. ČIŽMÁŘ, Contacts between Moravia and the territory of the Scordisci. In: H. DOBRZAŇSKA, V. MEGAW, P. POLESKA (Eds.), *Celts on the Margin: Studies in European Cultural Interaction, 7th Century BC–1st Century AD, Dedicated to Zenon Woźniak, Krakow* 2005, 131–134.
- ČIŽMÁŘ 2008  
 M. ČIŽMÁŘ, Latènezeitliche bronzene Hand- und Fussanhänger aus Mähren, *Archäologisches Korrespondenzblatt* 38/1, 2008, 81–85.
- ČIŽMÁŘ 2010  
 M. ČIŽMÁŘ, Zwei Typen spätlatènezeitlicher Gegenstände aus Mähren, *Archäologisches Korrespondenzblatt* 40/3, 2010, 383–388.
- ČURČIĆ 1909  
 V. ČURČIĆ, Prähistorische Funde aus Bosnien und der Herzegowina in den Sammlungen des k. k. naturhistorischen Hofmuseums in Wien, *Wissenschaftliche Mittheilungen aus Bosnien und der Herzegovina* 11, 1909, 91–100.
- DALIĆ 1998  
 M. DALIĆ, Tipološko-statistička obrada kasnolatenske keramike iz utvrđenih naselja Orolik i Privlaka, *Opuscula Archaeologica Radovi Arheološkog zavoda* 22, 1998, 163–218.
- DEMETZ 1999  
 S. DEMETZ, Fibeln der Spätlatène- und frühen römischen Kaiserzeit in den Alpenländern, *Frühgeschichtliche und Provinzialrömische Archäologie. Materialien und Forschungen* 4, Rahden/Westf. 1999.
- DIMITRIJEVIĆ 1979  
 S. DIMITRIJEVIĆ, Arheološka topografija i izbor arheoloških nalaza s vinkovačkog tla. In: *Corolla memoriae Iosepho Brunšmid dicata. Izdanja Hrvatskog Arheološkog Društva* 4, 1979, 201–269.

- DIZDAR 1998  
M. DIZDAR, Nekropola keltsko-latenske kulture u Vinkovcima, *Obavijesti Hrvatskog Arheološkog Društva* 30/1, 1998, 38–43.
- DIZDAR 1999  
M. DIZDAR, Željezno doba. In: I. ISKRA-JANOŠIĆ et al., *Vinkovci u svijetu arheologije*, Katalog izložbe. Vinkovci 1999, 39–48.
- DIZDAR 2001a  
M. DIZDAR, Latenska naselja na vinkovačkom području. *Dissertationes et Monographiae* 3, Zagreb 2001.
- DIZDAR 2001b  
M. DIZDAR, Nalazišta latenske kulture na vinkovačkom području, *Prilozi Instituta za arheologiju u Zagrebu* 18, 2001, 103–134.
- DIZDAR 2003  
M. DIZDAR, Prilog poznavanju kasnoga latena u istočnoj Slavoniji, *Opuscula Archaeologica Radovi Arheološkog zavoda* 27, 2003, 337–349.
- DIZDAR 2006  
M. DIZDAR 2006, Nalazi staklenih narukvica latenske kulture u Podravini, *Prilozi Instituta za arheologiju u Zagrebu* 23, 2006, 67–128.
- DIZDAR 2012  
M. DIZDAR, The archaeological background to the formation of ethnic identities. In: B. MIGOTTI (Ed.), *The Archaeology of Roman Southern Pannonia: The State of Research and Selected Problems in the Croatian Part of the Roman Province of Pannonia*. *British Archaeological Reports, International Series* 2393, 2012, 117–136.
- DIZDAR, in press  
M. DIZDAR, *Traces of Late La Tène Cult Activities in Northern Croatia?*
- DIZDAR, RADMAN-LIVAJA 2004  
M. DIZDAR, I. RADMAN-LIVAJA, Finds of Roman Bronze Ware on Celtic sites in eastern Slavonia. In: LE SECRÉTAIRE DU CONGRÈS (Ed.), *Actes du XIVème Congrès UISPP, Université de Liège, Belgique, 2–8 septembre 2001, Section 13: Epoque romaine: sessions générales et posters*. *British Archaeological Reports, International Series* 1312, Oxford 2004, 49–53.
- DIZDAR, TONC 2014  
M. DIZDAR, A. TONC, Nuovi ritrovamenti di vaselame bronzeo tardorepubblicano a Blato in Slavonia (Croazia): Contatti tra Scordisci e l'Italia nel tardo La Tène. In: P. BARRAL, J.-P. GUILLAUMET, M.-J. ROULIERE-LAMBERT, M. SARACINO, D. VITALI (Eds.), *Les Celtes et le Nord de l'Italie (Premier et Second Âges du fer)*. *Actes du XXXVI<sup>e</sup> colloque international de l'A.F.E.A.F. (Vérone, 17–20 mai 2012)*. *Revue Archéologique de l'Est supplément* 36, Dijon 2014, 585–594.
- EGRI, RUSTOIU 2008  
M. EGRI, A. RUSTOIU, The social significance of conviviality in the Scordiscian environment. In: V. SÎRBU, S. L. VAIDA (Eds.), *Funerary Practices of the Bronze and Iron Ages in Central and South-Eastern Europe*. *Proceedings of the 9<sup>th</sup> International Colloquium of Funerary Archaeology, Bistrița, Romania May 9<sup>th</sup>–11<sup>th</sup>, 2008*, Cluj-Napoca 2008, 83–93.
- FEUGÈRE 1998  
M. FEUGÈRE, Amulettes en forme de pied, *Instrumentum* 8, 1998, 23.
- FIALA 1899  
F. FIALA, Bericht über die Ausgrabungen am Debelo brdo bei Sarajevo im Jahre 1895, *Wissenschaftliche Mittheilungen aus Bosnien und der Hercegovina* 6, 1899, 129–138.
- FILIPOVIĆ 2010  
S. FILIPOVIĆ, 2010, Lokalitet Osijek (Mursa) – Vojarna (Učiteljski fakultet), *Hrvatski arheološki godišnjak* 6 (2009), 2010, 37–42.
- FREY 1984  
O.-H. FREY, Ein seltenes Zaumzeug aus Caporetto/Kobarid. In: L. RUARO LOSERI (Ed.), *Preistoria del caput Adriae. Atti del convegno internazionale, Trieste 19–20 nov. 1983*. Udine 1984, 119–129.
- GABLER 2005  
D. GABLER, Augusteische Sigillaten in Budaörs: Italischer Import in der vorrömischen Zeit im pannonischen Raum, Die Grabungen in der spätlatènezeitlich-römischen Siedlung von Budaörs, *Acta archaeologica Academiae scientiarum Hungaricae* 56/1–3, 2005, 133–175.
- GEBHARD 1989  
R. GEBHARD, Der Glasschmuck aus dem Oppidum von Manching. *Ausgrabungen in Manching* 11, Stuttgart 1989.
- GOSTENČNIK 2001  
K. GOSTENČNIK, Die Spindelhaken aus Kupferlegierung vom Magdalensberg und aus Virunum in Kärnten, *Archäologisches Korrespondenzblatt* 31/4, 2001, 571–579.
- GOSTENČNIK 2009  
K. GOSTENČNIK, Die Stadt auf dem Magdalensberg, ein Zentrum der Textilwirtschaft im früh-römischen Noricum, *Carinthia I* 199, 2009, 23–59.
- GUILLAUMET 1977  
J.-P. GUILLAUMET, Les passoires de la fin de la La Tène en Gaule et dans le monde celtique, *Gallia* 35/2, 1977, 239–248.

- GUILLAUMET 1991  
J.-P. GUILLAUMET, Les passoires. In: M. FEUGÈRE, C. ROLLEY, La vaisselle tardo-républicaine en bronze. Dijon 1991, 89–95.
- GUŠTIN 1987  
M. GUŠTIN, La Tène fibulae from Istria, *Archaeologia Jugoslavica* 24, 1987, 43–56.
- GUŠTIN 1991  
M. GUŠTIN, Posočje in der jüngeren Eisenzeit, *Katalogi in Monografije* 27, Ljubljana 1991.
- HUNYADY 1944  
I. HUNYADY, Kelták a kárpátmedencében. *Dissertationes Pannonicae* 2/18, Budapest 1944.
- ILKIĆ 1999  
M. ILKIĆ, Hrvatsko Podunavlje u željeznom razdoblju – posljednje tisućljeće prije Krista. Unpublished MA thesis, Zagreb 1999.
- JACANOVIĆ 1987  
D. JACANOVIĆ, Keltski grob iz Kostolca, *Viminacium* 2, 1987, 7–17.
- JOVANOVIĆ, JOVANOVIĆ 1988  
B. JOVANOVIĆ, M. JOVANOVIĆ, Gomolava, Naselje mlađeg gvozdenog doba, Gomolava 2. Novi Sad – Belgrade 1988.
- KARWOWSKI 2004  
M. KARWOWSKI, Latènezeitlicher Glasringschmuck aus Ostösterreich. *Mitteilungen der Prähistorischen Kommission der Österreichischen Akademie der Wissenschaften* 55, Vienna 2004.
- KARWOWSKI 2009  
M. KARWOWSKI, A Celtic Hilltop Settlement on Oberleiserberg in Lower Austria, *Światowit – Supplement Series B: Barbaricum* 8, 2009, 115–131.
- KARWOWSKI, MILITKÝ 2011  
M. KARWOWSKI, J. MILITKÝ, The Oberleiserberg types in the context of Taurisci influences. In: M. GUŠTIN, M. JEVIĆ (Eds.), *The Eastern Celts: The Communities between the Alps and the Black Sea*. Koper – Belgrade 2011, 131–136.
- KOSORIĆ 1982  
M. KOSORIĆ, Rezultati istraživanja praistorijskih naselja na području Semberije, Članci i građa za kulturnu istoriju istočne Bosne 14, 1982, 121–132.
- KRIŽ 2001  
B. KRIŽ, Kelti v Novem mestu. Novo Mesto 2001.
- LAZAR 1996  
I. LAZAR, Latènezeitliche und frühromische Funde aus der Savinja in Celje, *Arheološki vestnik* 47, 1996, 279–296.
- ŁUCZKIEWICZ 2010  
P. ŁUCZKIEWICZ, Die spätlatènezeitlichen Trinkhornbeschläge: Zeugnisse germanischer Einflüsse im keltschen Gebiet? In: E. JEREM, M. SCHÖNFELDER, G. WIELAND (Eds.), *Nord – Süd. Ost – West: Kontakte während der Eisenzeit in Europa*. Akten der Internationalen Tagungen der AG Eisenzeit in Hamburg und Sopron 2002. *Archaeolingua* 17, Budapest 2010, 165–181.
- ŁUCZKIEWICZ, SCHÖNFELDER 2011  
P. ŁUCZKIEWICZ, M. SCHÖNFELDER, Untersuchungen zur Ausstattung eines späteisenzeitlichen Reiterkriegers aus dem südlichen Karpaten- und Balkanraum, *Jahrbuch des Römisch-Germanischen Zentralmuseums Mainz* 55/1, 2008, 2011, 159–210.
- MAJNARIĆ-PANDŽIĆ 1970  
N. MAJNARIĆ-PANDŽIĆ, Keltsko-latenska kultura u Slavoniji i Srijemu, *Acta Musei Cibalensis* 2, Vinkovci 1970.
- MAJNARIĆ-PANDŽIĆ 1972–1973  
N. MAJNARIĆ-PANDŽIĆ, Kasnolatenski keltski grobovi iz Sotina, *Vjesnik Arheološkog muzeja u Zagrebu* 3/6-7, 1972–1973, 55–74.
- MAJNARIĆ-PANDŽIĆ 1984  
N. MAJNARIĆ-PANDŽIĆ, Prilog problematici kasnolatenskih naselja u Slavoniji, *Opvscvla Archaeologica Radovi Arheološkog zavoda* 9, 1984, 23–34.
- MAJNARIĆ-PANDŽIĆ 1996a  
N. MAJNARIĆ-PANDŽIĆ, Einige Beispiele der spätlatènezeitlichen Siedlungen in Nordkroatien und ihre Beziehung zu den Zentren der frühen Romanisation, *Arheološki vestnik* 47, 1996, 257–265.
- MAJNARIĆ-PANDŽIĆ 1996b  
N. MAJNARIĆ-PANDŽIĆ, CORNACUM (Sotin) and CIBALAE (Vinkovci) as examples of the early Romanization of La Tène communities in southern Pannonia. In: Z. WOŽNIAK (Ed.), *Kontakte längs der Bernsteinstraße (zwischen Caput Adriae und den Ostseegebieten) in der Zeit um Christi Geburt*, Krakow 1996, 23–33.
- MAJNARIĆ-PANDŽIĆ 1997  
N. MAJNARIĆ-PANDŽIĆ, Nalaz vindeličkog statera iz Vinkovaca, *Opvscvla Archaeologica Radovi Arheološkog zavoda* 21, Zagreb 1997, 29–35.
- MAJNARIĆ-PANDŽIĆ 2008  
N. MAJNARIĆ-PANDŽIĆ, Another look at the silver jewelry from Psarjevo near Zelina in northwestern Croatia, *Archaeologia Adriatica* 2, 2008, 315–323.
- MAJNARIĆ-PANDŽIĆ 2009  
N. MAJNARIĆ-PANDŽIĆ, On the south Pannonian population in the Late Iron Age. In: G. TIEFENGRABER, B. KAVUR, A. GASPARI (Eds.), *Keltske študije II: Studies in Celtic Archaeology*. Papers in Honour of Mitja Guštin. *Protohistoire Européenne* 11, Montagnac 2009, 235–245.

- MARÁZ 2008  
B. MARÁZ, Archäologische Angaben zur Mittleren und Späten La Tène-Zeit in Südosttransdanubien, *Communicationes archaeologicae Hungaricae* 2008, 65–92.
- MARIĆ 1962  
Z. MARIĆ, Vir kod Posušja, *Glasnik Zemaljskog Muzeja Bosne i Hercegovine u Sarajevu: Arheologija NS* 17, 1962, 63–72.
- MARIĆ 1963  
Z. MARIĆ, Keltski elementi u mlađem željeznom dobu BiH, *Glasnik Zemaljskog Muzeja Bosne i Hercegovine u Sarajevu: Arheologija NS* 18, 1963, 63–83.
- MIRON 1991  
A. MIRON, Die späte Eisenzeit im Hunsrück-Nahe-Raum – Mittel- und spätlatènezeitliche Gräberfelder. In: A. HAFNER, A. MIRON (Eds.), *Studien zur Eisenzeit im Hunsrück-Nahe-Raum: Symposium Birkenfeld 1987*, *Trierer Zeitschrift für Geschichte und Kunst des Trierer Landes und seiner Nachbargebiete Supplement* 13, Trier 1991, 151–169.
- MISKE 1908  
K. MISKE, Die Prähistorische Ansiedlung Velem St. Vid 1: Beschreibung der Raubbaufunde, Vienna 1908.
- PAŠKLAVIN 2008  
V. PAŠKLAVIN, Kamenjača, Breza kod Sarajeva – mladežljeznodobna i rimska nekropola, *Godišnjak CBI (Centar za balkanološka ispitivanja)* 37/35, 2008, 101–179.
- PESCHECK 1989  
C. PESCHECK, Wichtige Neufunde von der Birg bei Hohenschäftlarn, *Bayerische Vorgeschichtsblätter* 54, 1989, 219–229.
- POPOVIĆ 1978  
P. POPOVIĆ, Ostava drahmi Apolonije i Dirahiona iz Pećinaca, *Numizmatičar* 1, 1978, 9–22.
- POPOVIĆ 1987  
P. POPOVIĆ, Novac Skordiska, Novac i novčani promet na centralnom Balkanu od IV. do I. veka pre n. e., *Belgrade – Novi Sad* 1987.
- POPOVIĆ 1992  
P. POPOVIĆ, Italische Bronzegefäße im Skordiskergebiet, *Germania* 70/1, 1992, 61–74.
- POPOVIĆ 1994  
P. POPOVIĆ, Lanzenfibeln des Westbalkans und der Donauniederung, *Balkanica* 25/1, 1994, 53–71.
- POPOVIĆ 1997  
P. POPOVIĆ, Les perles de verre en forme de vase ou d'amphore sur l'espace entre la mer Adriatique et le Danube, *Starinar* 48, 1997, 165–171.
- POPOVIĆ 2001  
P. POPOVIĆ, La céramique de la La Tène Finale sur les Territoires de Scordisques (Ier siècle av. n. è. – Ier siècle de n. è.), *Starinar* 50/2000, 2001, 83–111.
- POPOVIĆ 2003a  
P. POPOVIĆ, Le site laténien de Dautovac-Korićani et les fibules ornées de “boucles” ou de “huit” (À brandebourgs), *Starinar* 52/2002, 2003, 145–155.
- POPOVIĆ 2003b  
P. POPOVIĆ, Gradina na Bosutu kod Vašice, *Opvscvlva Archaeologica Radovi Arheološkog zavoda* 27, 2003, 311–320.
- RADIMSKÝ 1893  
W. RADIMSKÝ, Die Alterthümer der Hochebene Rakitno in der Hercogovina, *Wissenschaftliche Mittheilungen aus Bosnien und der Hercegovina* 1, 1893, 169–179.
- RADIMSKÝ 1895  
W. RADIMSKÝ, Archäologische Tagebuchblätter, *Wissenschaftliche Mittheilungen aus Bosnien und der Hercegovina* 3, 1895, 284–297.
- RIECKHOFF 1995  
S. RIECKHOFF, Süddeutschland im Spannungsfeld von Kelten, Germanen und Römern, *Studien zur Chronologie der Spätlatènezeit im südlichen Mitteleuropa*, *Trierer Zeitschrift, Beiheft* 19, Trier 1995.
- RUSTOIU 2005  
A. RUSTOIU, The Illyrian-Celtic belts with bronze double studs from the Scordisci area, *Instrumentum* 22, 2005, 30–31.
- RUSTOIU 2011  
A. RUSTOIU, Celto-Pontica: connections of the Celts from Transylvania with the Black Sea, *Pontica* 44, 2011, 91–111.
- RUSTOIU, SÎRBU, FERENCZ 2001–2002  
A. RUSTOIU, V. SÎRBU, I. V. FERENCZ, Mormântul tumular dacic de la Călan (jud. Hunedoara), *Sargetia* 30, 2001–2002, 111–127.
- SALAČ 2011  
V. SALAČ, Oppida a urbanizační procesy ve střední Evropě, *Archeologické rozhledy* 63/1, 2011, 23–64.
- SCHÖNFELDER 2002  
M. SCHÖNFELDER, Das spätlatènezeitliche Wagengrab von Boé (Dép. Lot-et-Garonne). *Studien zu Wagen und Wagengräbern der jüngeren Latènezeit. Monographien des Römisch-Germanischen Zentralmuseums Mainz* 54, 2002.
- SCHÖNFELDER 2007  
M. SCHÖNFELDER, Zurück aus Griechenland – Spuren keltischer Söldner in Mitteleuropa, *Germania* 85/2, 2007, 307–328.
- SLADIĆ 1991  
M. SLADIĆ, Fibule tipa Jarak sa lokaliteta Židovar u Banatu, *Rad vojvodanskih muzeja* 33, 1991, 23–27.

SLADIĆ 2006

M. SLADIĆ, Sadržaj ostave i stilsko-tipološka analiza Židovarskog blaga. In: M. JEVTIĆ, M. LAZIĆ, M. SLADIĆ, Židovarsko blago, Ostava srebrnog nakita iz naselja Skordiska. Vršac – Belgrade 2006, 29–80.

STOJIC 2000

M. STOJIC, Najnoviji slučajni nalazi fibula iz gvođenog doba u dolini Mlave, *Viminacium* 11, 2000, 57–67.

STOJIC 2003

M. STOJIC, Veliki Vetren, Arheološki institut. Posebna izdanja 38, Belgrade 2003.

ŠIMIĆ 1997

J. ŠIMIĆ, Kelti. In: J. ŠIMIĆ, S. FILIPOVIĆ, Kelti i Rimljani na području Osijeka, Osijek 1997, 3–49.

TODOROVIĆ 1971

J. TODOROVIĆ, Katalog praistorijskih metalnih predmeta. Belgrade 1971.

TODOROVIĆ 1972

J. TODOROVIĆ, Praistorijska Karaburma I – nekropola mlađeg gvođenog doba. *Dissertationes et Monographiae* 13, Belgrade 1972.

TODOROVIĆ 1974

J. TODOROVIĆ, Skordisci. *Monumenta Archaeologica* 2, Novi Sad – Belgrade 1974.

TORBAGY 1993

M. TORBAGY, Umlauf der Münzen von Apollonia und Dyrrhachium im Karpatenbecken. In: T. HACKENS, Gh. MOUCHARTE (Eds.), *Actes du XIe Congrès International de Numismatique* 1. Louvain-de-Neuve 1993, 119–122.

TRUHELKA 1902

Ć. TRUHELKA, Zwei prähistorische Funde aus Gorica (Bezirk Ljubuški), *Wissenschaftliche Mittheilungen aus Bosnien und der Hercegovina* 8, 1902, 3–47.

TRUHELKA 1904

Ć. TRUHELKA, Der vorgeschichtliche Pfahlbau im Savebette bei Donja Dolina (Bezirk Bosnisch-Gradiška), Bericht über die Ausgrabungen bis 1904, *Wissen-*

*schaftliche Mittheilungen aus Bosnien und der Hercegovina* 9, 1904, 1–156.

UJES-MORGAN 2012

D. UJES-MORGAN, 1<sup>st</sup> century BC drachms of Apollonia and Dyrrhachium in the territory of the Scordisci. A prologue to the Roman conquest of the Balkans. In: E. PAUNOV, S. FILIPOVA (Eds.), *Studia in honorem Iliae Prokopov sexagenario ab amicis et discipulis dedicata*. Tîrnovi 2012, 367–387.

VENCLOVÁ 2002

N. VENCLOVÁ, External contacts. Visible and invisible. In: A. LANG, V. SALAČ (Eds.), *Fernkontakte in der Eisenzeit*. Konferenz Liblice 2000. Prague 2002, 72–82.

WARNEKE 1999

T. F. WARNEKE, Hallstatt- und frühlatènezeitlicher Anhängerschmuck, *Studien zu Metallanhängern des 8.–5. Jahrhunderts v. Chr. zwischen Main und Po*. *Internationale Archäologie* 50, Rahden/Westf. 1999.

ZACHAR, REXA 1988

L. ZACHAR, D. REXA, Beitrag zur Problematik der spätlatènezeitlichen Siedlungshorizonte innerhalb des Bratislavaer Oppidums, *Zborník Slovenského národného múzea* 81, *Historia* 28, 1988, 27–72.

ZEPEZAUER 1993

M. A. ZEPEZAUER, Mittel- und spätlatènezeitliche Perlen, Glasperlen der vorrömischen Eisenzeit III. *Marburger Studien zur Vor- und Frühgeschichte* 15, Maribor 1993.

ZIRRA 1981

V. ZIRRA, Latènezeitliche Trensens in Rumänien, *Marburger Beiträge zur Archäologie* 8, 1981, 115–171.

*Dr. sc. Marko Dizdar  
Institut za arheologiju  
Ulica Ljudevita Gaja 32,  
10000 Zagreb  
Croatia  
marko.dizdar@iarh.hr*



# Contacts between the Boii and the Scordisci: The Case of the Oberleiserberg Type Fibulae

Ivan Drnić

**Abstract:** A small group of Late La Tène cast fibulae originates from the area of southeastern Pannonia. With the exception of the find from the site of Blato, near Vinkovci, which belongs to the Oberleiserberg type, the fibulae from Dalj, Novi Jankovci and Novi Banovci can be described as copies of the same type produced in local workshops. In addition to a reinterpretation of the form, in the case of southeastern Pannonian specimens we can also witness a transfer of technology, since two-part cast fibulae consist of a specific combination of two alloys, tin-bronze and leaded bronze. The communication between Lower Austria, settled during the Late La Tène period by communities known as the Boii, and southeastern Pannonia is additionally corroborated by several finds from the Oberleiserberg settlement, such as fibulae of the Vinkovci type or coins of the Syrmian type, which represent characteristic objects of the Scordiscan material culture.

**Keywords:** Late La Tène period, southeastern Pannonia, cast fibulae, Oberleiserberg type, communication networks, local production.

**Zusammenfassung:** Eine kleine Gruppe von gegossenen Spätlatène-Fibeln stammt aus dem Gebiet des südöstlichen Pannonien. Mit Ausnahme des Fundes von Blato in der Nähe von Vinkovci, der dem Typ Oberleiserberg angehört, können die Fibeln aus Dalj, Novi Jankovci und Novi Banovci als Kopien des gleichen Typs aus lokalen Werkstätten beschrieben werden. Zusätzlich zu einer Neuinterpretation der Form sind wir im Fall der südöstlichen pannonischen Exemplare auch Zeugen eines Technologietransfers, da zweiteilige gegossene Fibeln aus einer speziellen Kombination zweier Legierungen, nämlich Zinn-Bronze und Blei-Bronze, bestehen. Die Kommunikation zwischen Niederösterreich, welches in der späten Latènezeit von Gemeinschaften besiedelt wurde, die als Boier bekannt sind, und dem südöstlichen Pan-

nonien wird zusätzlich durch mehrere Funde der Siedlung vom Oberleiserberg, wie Fibeln des Vinkovci Typs oder Münzen des Syrmischen Typs, die charakteristische Objekte der materiellen Kultur der Skordisker darstellen, bestätigt.

**Stichwörter:** Spätlatènezeit, Südost-Pannonien, gegossene Fibeln, Typ Oberleiserberg, Kommunikationsnetzwerke, Lokalproduktion.

## Introduction

Cast fibulae of the “pseudo-Middle La Tène” construction are a characteristic part of attire in the western Carpathian Basin in the Late La Tène period. Many finds are known from the area of today’s Slovenia, Austria and western Hungary, which have been classified as several different types based on their morphological characteristics.<sup>1</sup> Generally, the construction of all these fibulae, regardless of the type, mimics Middle La Tène forms with the bow and the inverted foot cast together to form the closed frame of triangular or trapezoidal shape. A knob, or “false collar” (*Pseudofußklammer*), is placed at the end of the foot, imitating the constructional element which tied the foot to the bow in Middle La Tène fibulae. The foot is decorated with smooth or ribbed knobs, and the spring is composed of several coils connected by an external chord.

Late La Tène cast fibulae are rare and usually appear as stray finds in southeastern Pannonia on sites like Dalj, Novi Banovci, Novi Jankovci and Sotin (Fig. 1).<sup>2</sup> However, recent excavations at the Blato site near Vinkovci have yielded several cast fibulae, amongst them a Szalacska

1. MISKE 1908, 50–51. – DIZDAR, BOŽIČ 2010, 145–160. – KARWOWSKI, MILITKÝ 2011, 134–135.

2. BRUNŠMID 1902, 72, Fig. 32. – MAJNARIĆ-PANDŽIĆ 1970, 20, Pls. IV/7 and XXII/6. – ILKIĆ 1999, 77, Pl. XXI/5. – DRNIĆ 2012, 225–238.

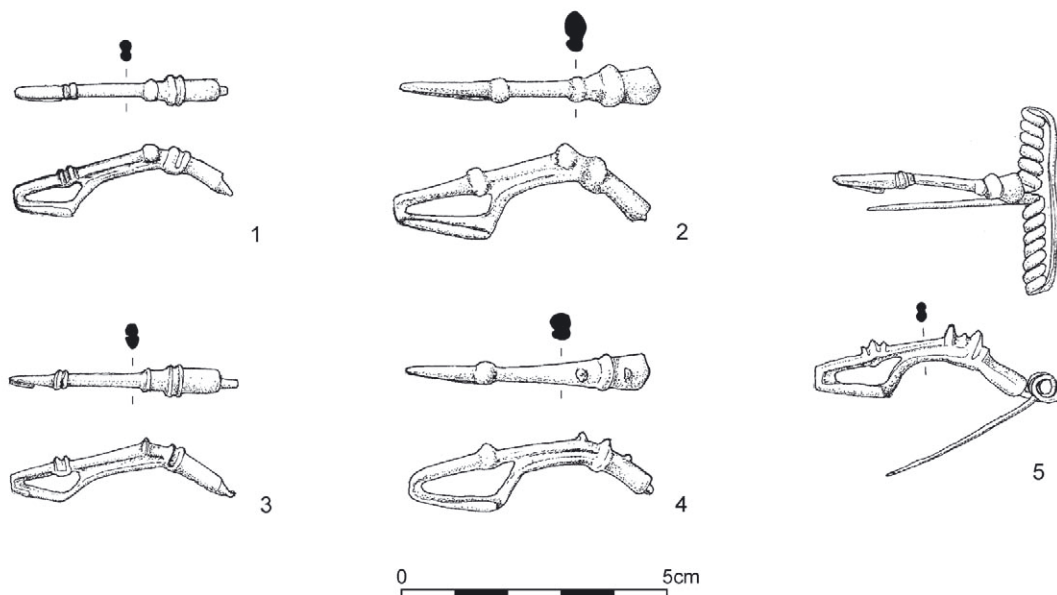

Fig. 1. Late La Tène cast fibulae from southeastern Pannonia. – 1–3. Novi Banovci – 4. Dalj. – 5. Novi Jankovci (after DRNIĆ 2012).

type<sup>3</sup> and an Oberleiserberg type fibula. The latter type was named after a site in Lower Austria that yielded over three hundred fibulae, twenty-eight of them cast from a copper alloy (Fig. 2).<sup>4</sup> Based on the archaeological context and the stylistic characteristics of the finds, this type can be dated to the phase LT D1,<sup>5</sup> just like other types of Late La Tène cast fibulae.

Considering the range of finds, primarily metal objects like horse gear, fibulae and Late Republican bronze vessels, the open settlement at Blato can be considered a distribution and production centre in a network of long-distance trade and exchange connections with the most intensive activity in LT D1 period.<sup>6</sup> These kinds of settlements are well known in the territories of the La Tène culture and date from the first half of the 3<sup>rd</sup> century to the 1<sup>st</sup> century BC.<sup>7</sup> At special central sites of the Némčice-Roseldorf type, numerous finds of extraordinary and high quality have been made.<sup>8</sup>

Cast fibulae of the pseudo-Middle La Tène construction were very popular in the phase LT D1 in the western part of the Carpathian Basin. One can assume that a certain number of these objects, including those of the Oberleiserberg type, were made at the eponymous site, but they could have just as easily been produced at work-

shops in other settlements and imported into southeastern Pannonia. For example, a large number of Late La Tène cast fibulae were found at the oppidum Velem Szentvid, and several finds were attributed to the Oberleiserberg type,<sup>9</sup> which points to the possibility that these items were produced at the site or that this site might have been a distribution point for fibulae made at the Oberleiserberg settlement and possibly in some other, as yet undiscovered, production centre. The relatively small number of these fibulae from southeastern Pannonia, points to the fact that they were not a part of the indigenous attire of the Scordisci, but rather of foreign influence.

#### Discussion

Apart from the aforementioned fibula from Blato (Fig. 6/1), which, based on its morphological characteristics can be classified as of Oberleiserberg type, several other specimens from southeastern Pannonia display certain features characteristic of this type, which suggests a possible copying of original items in local workshops. For example, two fibulae from Novi Banovci (Fig. 1/1, 3) closely resemble the Oberleiserberg ones. However, the finds differ in certain details. The heads of the original fibulae are significantly wider than the bows, while in those from Novi Banovci, the head and the bow are of equal width. The third fibula from Novi Banovci (Fig. 1/2) diverges even further from the original model. It is generally coarser than the other two finds, and its false collar is coarsely made, making this fibula bigger

3. This term was suggested by D. Božič and used by M. Dizdar (see his article in this volume).

4. KARWOWSKI 2009, 118. – KARWOWSKI, MILITKÝ 2011, 134.

5. KARWOWSKI, MILITKÝ 2011, 135.

6. See M. Dizdar's article in this volume.

7. MOORE et al. 2014. – WENDLING 2014.

8. SALAČ 2011, 63–64.

9. MISKE 1908, Pls. XL/25,30 and XLII/50.

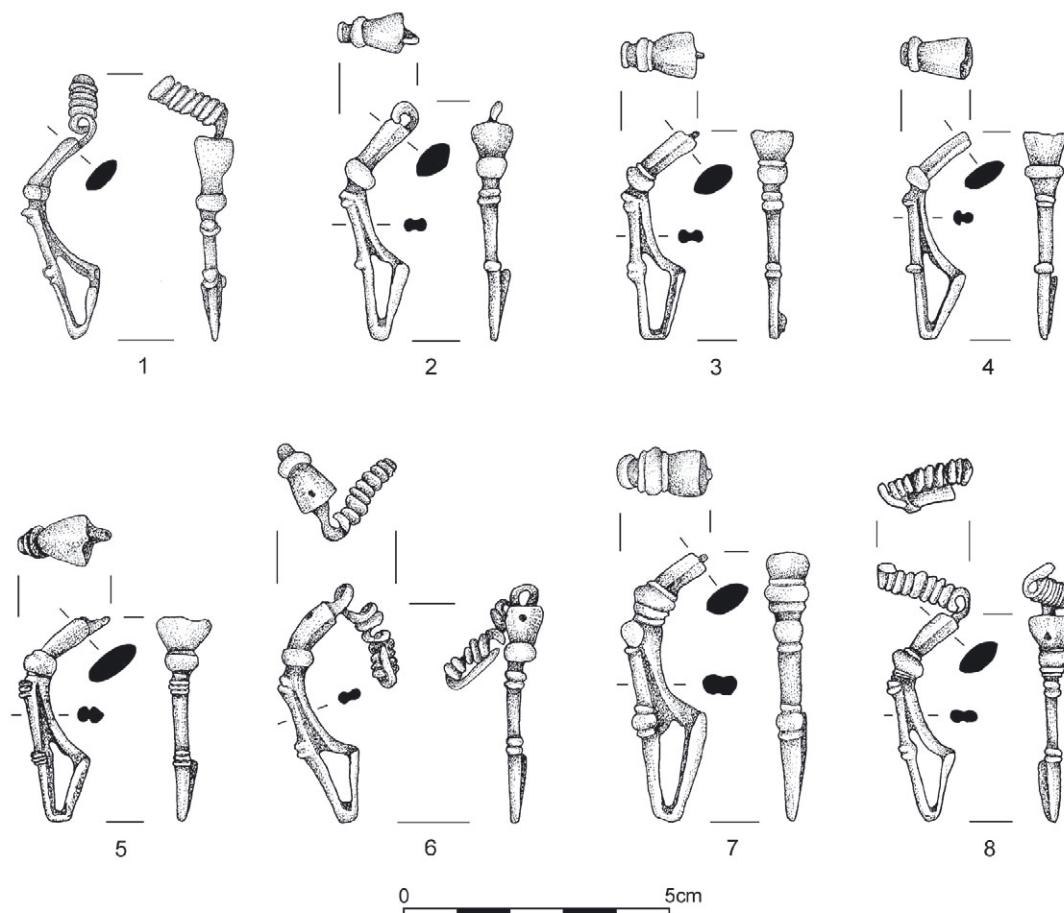

Fig. 2. Fibulae of the Oberleiserberg type (after KERN 1996, KARWOWSKI 2009, KARWOWSKI, MILITKÝ 2011).

and heavier than the first two, which might point to a different style of wearing. The fibula from Dalj (Fig. 1/4) also greatly diverges from the original model. Its bow is shaped like those on fibulae from Novi Banovci, but its foot is slightly curved and its second knob appears degenerated. Another small knob on the other side of the false collar forms a feature unidentified in other Late La Tène cast fibulae. The find from Novi Jankovci (Fig. 1/5) exhibits a somewhat different shape of bow and a ribbed false collar unlike anything found at the eponymous site.

The finds from southeastern Pannonia are not unique in that it has already been noted that foreign objects were copied in local workshops. This process often changes the features of the original model, and does so for many different reasons. It can be a question of appealing to the tastes of the users, the technological abilities of the local population, or the individual skill of the craftsman making the object. Several finds from Blato speak in favour of this latter proposition. A coarse copy of an Almgren 65 type fibula<sup>10</sup> was found, as well as copy of the later

Jezerine fibula type<sup>11</sup> (Fig. 3/1, 2). Copies of fibulae of the Jezerine type were also found on other southeast Pannonian sites which, along with other original objects, bears witness to the popularity of these items in the 1<sup>st</sup> century BC.<sup>12</sup> A similar case has been noted at the site of Piatra-Craivii in neighbouring Dacia, in the context of the Padea-Panagjurski Kolonii group, where an iron hybrid form of the Jezerine fibula was found.<sup>13</sup> Furthermore, fibulae of the Vinkovci type, characteristic of the western Scordiscian area, were produced as a variant of the Nauheim fibula type which has been adjusted to suit the taste of the local population.<sup>14</sup>

The way Late La Tène cast fibulae were made is also quite interesting. The bow and the foot of the fibulae were cast in a mould like the one found at the Szalacska site in

11. DIZDAR 2003, 343, Pl. 1/11.

12. DEMETZ 1999, 102, 248, 250–251, Map 29. – ILKIĆ 1999, 40–41, Pl. XXIII/1–2, 4–5, 8–9. – DIZDAR 2001, 110–111, Pl. 76. – DRNIĆ 2013, 45–68.

13. RUSTOIU, GHEORGHIU 2010, 447–457.

14. DIZDAR 2003, 342–343. – MAJNARIĆ-PANDŽIĆ 2009, 238–240, Figs. 1–4.

10. DIZDAR 2001, 111, Pl. 4/12.

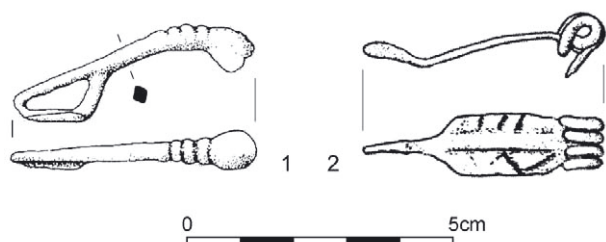

Fig. 3. Copies of Almgren 65 (1) and Jezerine type (2) fibulae from the La Tène settlement at Blato near Vinkovci (after DIZDAR 2001 and DIZDAR 2003).



Fig. 4. The head of the fibula from Novi Banovci with inserted wire (Photo: I. Krajcar).

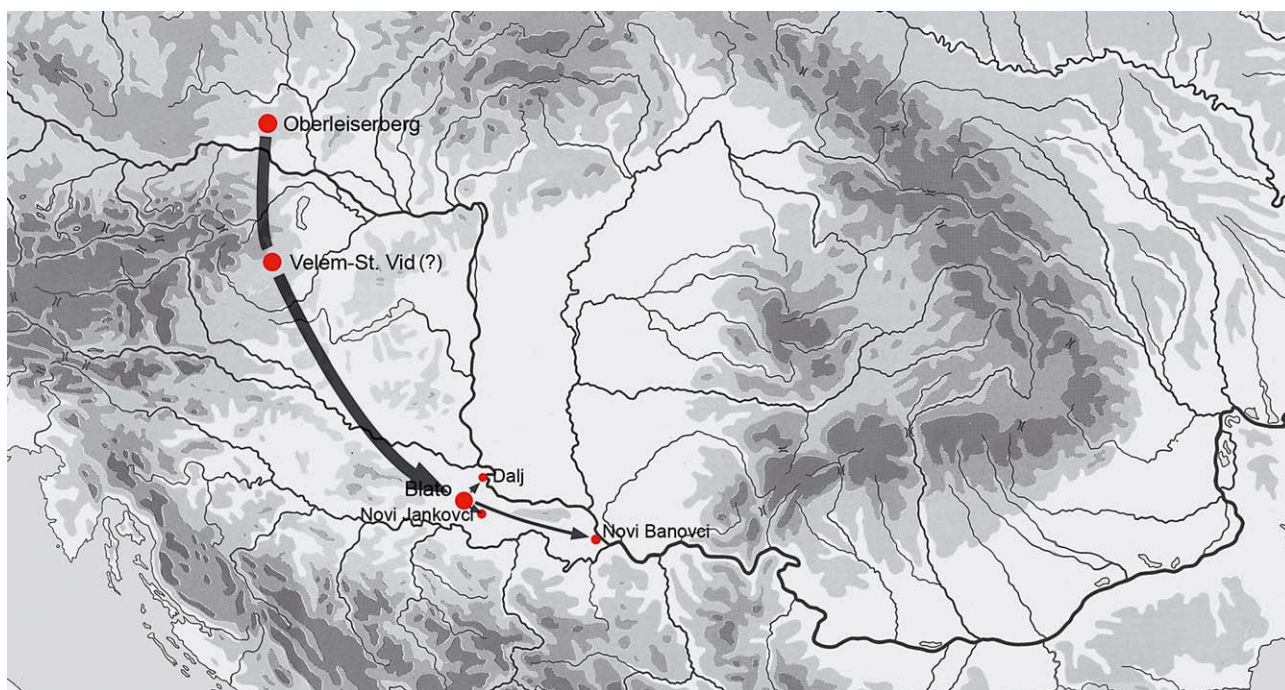

Fig. 5. Possible direction of influence for Late La Tène cast fibulae.

Hungary.<sup>15</sup> The spring was made of wires with different cross-sections and inserted into the head. These elements were made of different copper alloys and the difference can often be observed with the naked eye. The lead alloy used for the bows is darker, and the springs have a vivid green patina, as can be seen on some items from the Oberleiserberg.<sup>16</sup> The same technology was used to make other types of Late La Tène fibulae. For example, the bow and foot of the fibula resembling the Magdalenska gora type from the site of Kiškoriya-Sjever near Virovitica (the eastern border of the Mokronog group) were made of a copper, tin and lead alloy, while lead was absent from the wire of the spring.<sup>17</sup> The finds from Dalj, Novi Banovci and

Novi Jankovci, were produced in the same way (Fig. 4), as shown by SEM-EDX analyses. A high percentage of lead was found, between 8 and 19 %, in the bodies of the fibulae, while the only preserved spring from Novi Banovci did not contain lead, but only tin and copper.<sup>18</sup>

### Conclusion

From these findings, it is possible to suggest a model that explains the existence of Late La Tène cast fibulae in southeastern Pannonia. Because of their popularity in the western part of the Carpathian Basin, a certain number of these objects reached the Scordiscian area, as shown by the finds from the site of Blato, where the region's production and distribution centre was located (Fig. 5).

15. DARNAY 1906, 420, Fig. 11.

16. KARWOWSKI, MILITKÝ 2011, 134, Fig. 3.

17. DIZDAR, BOŽIĆ 2010, 147–148.

18. MÖDLINGER, DRNIĆ, PICCARDO 2012, 1343–1349, Pl. 2.



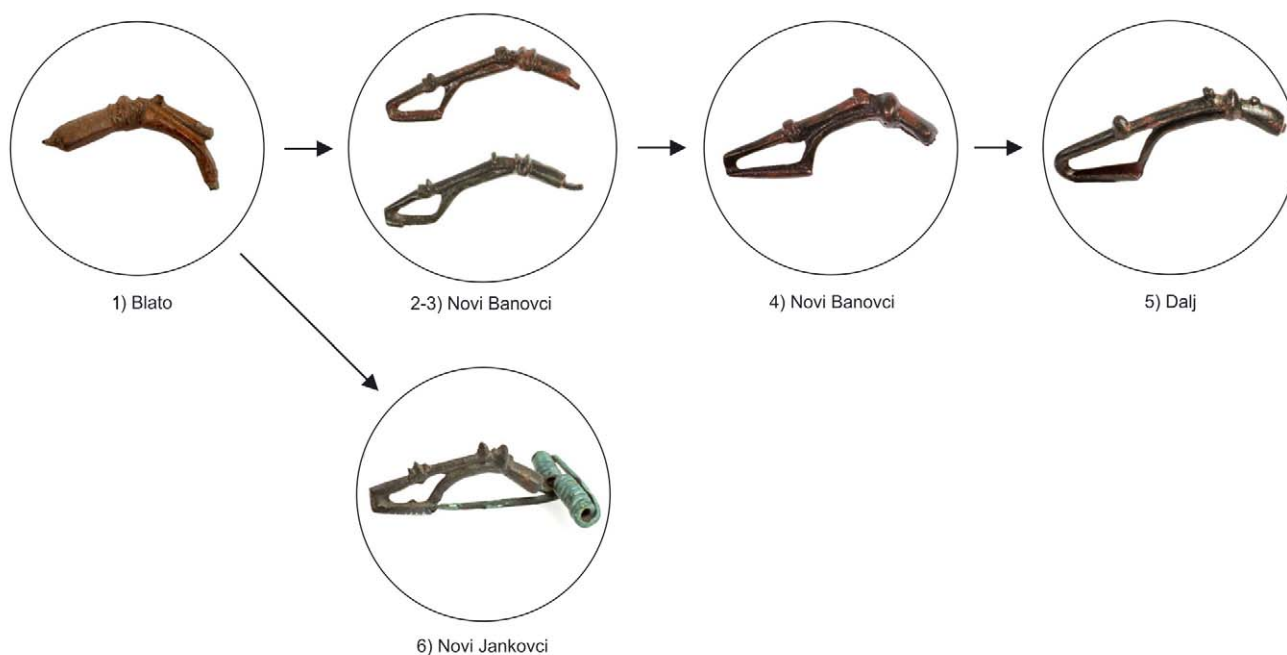

Fig. 6. A model of copying and reinterpreting cast fibulae of the Oberleiserberg type in southeastern Pannonian workshops (Photos: M. Dizdar and I. Krajcar).

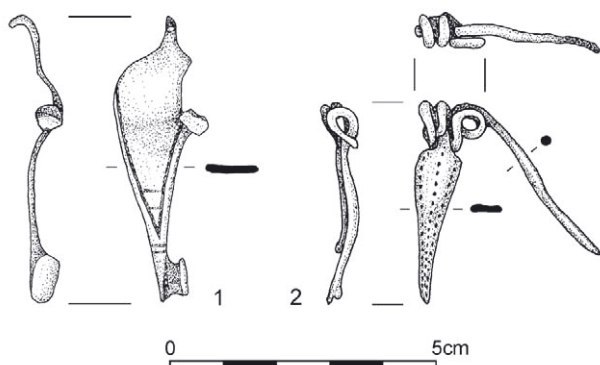

Fig. 7. Two fibulae of the Vinkovci type from the Oberleiserberg (after KARWOWSKI 2009).

Whether it was due to trade or some other mechanism like individual mobility (a well-known La Tène phenomenon), is yet to be determined. These fibulae served as a basis for local copies which diverged from the originals, in some cases more, in others less (Fig. 6). This process is also attested in other copied types of Late La Tène fibulae, for example the Almgren 65, and Jezerine types, which were found in Blato and were most likely also produced in other Scordiscian workshops.

Apart from reinterpreting the popular form of attire, a new technology was accepted which differed from the one used in the production process in metal workshops

of southeastern Pannonia thus far. The addition of lead increased the viscosity of the alloy, which made casting easier. The pin and the spring, in contrast, were made of copper and tin, a better combination when one considers the essential characteristics of these elements – properties of hardness and elasticity – which were additionally increased by smithing.

Communication did not flow exclusively from the north to the east; several finds from the La Tène settlement on the Oberleiserberg, primarily two fibulae of the Vinkovci type (Fig. 7),<sup>19</sup> a few coins of the Syrmian type and a characteristic knife with a curved blade<sup>20</sup> document this fact. Key points in the communication networks were regional trade and exchange as well as production centres. Some of them, such as the oppidum of Velem Szentvid or the open settlement at Blato, are already known, others are still waiting to be discovered. Although not numerous, these finds testify to the dynamic, albeit insufficiently known, relations between the populations known to us as the Scordisci and the Boii from ancient sources (the latter inhabiting the settlement at the Oberleiserberg).

*(Translated by Ana Đukić)*

19. KERN 1996, 388, Fig. 7. – KARWOWSKI 2009, Fig. 8.

20. See M. Karwowski's article in this volume.



## References

- BRUNŠMID 1902  
 J. BRUNŠMID, Prehistorijski predmeti iz srijemske županije, *Vjesnik Hrvatskoga Arheološkoga Društva* NS 6, 1902, 68–86.
- DARNAY 1906  
 K. DARNAY, Kelta pénzverő és öntő-műhely Szalacsán (Somogy M.), *Archaeologia Értesítő* 26, 1906, 416–433.
- DEMETZ 1999  
 S. DEMETZ, Fibeln der Spätlatène- und frühen römischen Kaiserzeit in den Alpenländern. Frühgeschichtliche und provinzialrömische Archäologie. Materialien und Forschungen 4, Rahden/Westf. 1999.
- DIZDAR 2001  
 M. DIZDAR, Nalazišta latenske kulture na vinkovačkom području. Prilozi Instituta za arheologiju u Zagrebu 18, 2001, 103–134.
- DIZDAR 2003  
 M. DIZDAR, Prilog poznavanju kasnog latena u istočnoj Slavoniji, *Opuscula Archaeologica Radovi Arheološkog zavoda* 27, 2003, 337–349.
- DIZDAR, BOŽIĆ 2010  
 M. DIZDAR, D. BOŽIĆ, O nekim oblicima fibula s kasno-latenskog naselja Virovitica-Kiškorija sjever, Prilozi Instituta za arheologiju u Zagrebu 27, 2010, 145–160.
- DRNIĆ 2012  
 I. DRNIĆ, Kasnolatenske lijevane fibule s prostora jugoistočne Panonije, *Vjesnik Arheološkog muzeja u Zagrebu* 45, 2012, 225–238.
- DRNIĆ 2013  
 I. DRNIĆ, Fibule tipa Jezerine s prostora jugoistočne Panonije, Prilozi Instituta za arheologiju u Zagrebu 30, 2013, 45–68.
- ILKIĆ 1999  
 M. ILKIĆ, Hrvatsko Podunavlje u željeznom razdoblju – posljednje tisućljeće prije Krista. Unpublished MA thesis, Zagreb 1999.
- KARWOWSKI 2009  
 M. KARWOWSKI, A Celtic hilltop settlement on Oberleiserberg in Lower Austria, *Światowit – Supplement Series B: Barbaricum* 8, 2009, 115–131.
- KARWOWSKI, MILITKÝ 2011  
 M. KARWOWSKI, J. MILITKÝ, The Oberleiserberg types in the context of Taurisci influences. In: M. GUŠTIN, M. JEVTIĆ (Eds.), *The Eastern Celts: The Communities between the Alps and the Black Sea*. Koper – Belgrade 2011, 131–136.
- KERN 1996  
 A. KERN, Spätlatènezeitliche Funde vom Oberleiserberg, MG Ernstbrunn, NÖ. In: E. JEREM, A. KRENN-LEEB, J.-W. NEUGEBAUER, O. URBAN (Eds.), *Die Kelten in den Alpen und an der Donau*. Budapest – Vienna 1996, 385–393.
- MAJNARIĆ-PANDŽIĆ 1970  
 N. MAJNARIĆ-PANDŽIĆ, Keltsko-latenska kultura u Slavoniji i Srijemu. *Acta Musei Cibalensis* 2, Vinkovci 1970.
- MAJNARIĆ-PANDŽIĆ 2009  
 N. MAJNARIĆ-PANDŽIĆ, On the south Pannonian population in the Late Iron Age. In: G. TIEFENGRABER, B. KAVUR, A. GASPARI (Eds.), *Keltske študije II. Studies in Celtic Archaeology. Papers in Honour of Mitja Guštin*. *Protohistoire Européenne* 11, Montagnac 2009, 235–245.
- MISKE 1908  
 K. MISKE, Die prähistorische Ansiedlung Velem St. Vid 1: Beschreibung der Raubbaufunde. Vienna 1908.
- MÖDLINGER, DRNIĆ, PICCARDO 2012  
 M. MÖDLINGER, I. DRNIĆ, P. PICCARDO, Alloying elements as chronotechnological marker for second and first century BC fibulae from ancient Pannonia, *Journal of Materials* 64/11, 2012, 1343–1349.
- MOORE et al. 2014  
 T. MOORE, A. BRAUN, J. CREIGHTON, L. CRIPPS, P. HAUPT, I. KLENNER, P. NOUVEL, M. SCHÖNFELDER, Oppida, agglomerations, and suburbia: the Bibracte environs and new perspectives on Late Iron Age urbanism in central-eastern France, *European Journal of Archaeology* 16/3, 2014, 491–517.
- RUSTOIU, GHEORGHIU 2010  
 A. RUSTOIU, G. GHEORGHIU, ‘General’ and ‘particular’ in the dressing fashion and metalwork of pre-Roman Dacia (An iron variant of the Jezerine-type brooches from Pietra Craivii – Alba County). In: I. CANDEA (Ed.), *The Thracians and their Neighbours in Antiquity*. *Studia in Honorem Valerii Sirbu*, Braila 2010, 447–457.
- SALAČ 2011  
 V. SALAČ, Oppida a urbanizační procesy ve střední Evropě, *Archeologické rozhledy* 63, 2011, 23–64.
- WENDLING 2014  
 H. WENDLING, Manching reconsidered: new perspectives on settlement dynamics and urbanisation in Iron Age central Europe, *European Journal of Archaeology* 16/3, 2014, 459–490.

*Ivan Drnić*  
*Arheološki muzej u Zagrebu*  
*Trg Nikole Šubića Zrinskog 19*  
*10000 Zagreb*  
*Croatia*  
*idrnica@amz.hr*

# Bronze Fibulae of the Zvonimirovo Type among the Taurisci and Boii

Dragan Božič

**Abstract:** The author of this contribution suggests combining two groups of bronze fibulae of Middle La Tène construction under the name “fibulae of the Zvonimirovo type”. For the typologically most closely related variants a, b and c1, closed grave groups from Zvonimirovo provide us with a date of LT C2. Variant c2, however, seems to date to LT D1.

**Keywords:** La Tène period, Taurisci, Boii, fibulae, typology.

**Zusammenfassung:** Der Verfasser dieses Beitrags schlägt die Vereinigung zweier Gruppen von Bronzefibeln vom Mittellatèneschema unter der Bezeichnung „Fibeln vom Typ Zvonimirovo“ vor. Während uns die sicheren Grabverbände aus Zvonimirovo für die typologisch aufs Engste verwandten Varianten a, b und c1 eine Datierung in die Stufe LT C2 liefern, scheint Variante c2 eher in die Stufe LT D1 zu datieren.

**Stichwörter:** Latènezeit, Taurischer, Boier, Fibeln, Typologie.

## History of Research

### *The cemetery of Golek pri Vinici in the Kolpa Valley*

The first illustrations of fibulae of the Zvonimirovo type (Fig. 1) appeared in the auction catalogue of the Mecklenburg collection, which was printed in New York in 1934.<sup>1</sup> It is a small selection of fibulae which had come to light in graves of a very large flat grave cemetery containing nearly 350 burials. The cemetery had been excavated by the Duchess of Mecklenburg in 1906 and 1907 at a location named Stražni dol in the vicinity of the village of Golek pri Vinici in Bela krajina.<sup>2</sup> Emil Vogt (of the Swiss

National Museum in Zurich), who penned a chapter on the Golek pri Vinici cemetery – generally abbreviated to Vinica cemetery – for this catalogue, did not pay particular attention to the fibulae of the Zvonimirovo type.<sup>3</sup> The cemetery of Golek pri Vinici is the eponymous site of the Vinica group, one of four Late Iron Age culture groups in Slovenia.<sup>4</sup>

### *The cemetery of Valična vas in the Krka Valley*

Biba Teržan was the first to consider the fibulae of the Zvonimirovo type as a specific group of bronze fibulae of Middle La Tène construction; however, she only defined – in accordance with the state of research and publication of the time – the form that is characterised by rhomboidal expansion of the head (Fig. 1/c). She undertook this as part of her 1971 diploma thesis on the Hallstatt and La Tène cemetery of Valična vas in the upper Krka Valley in Dolenjska, which was published in abridged form in 1975.<sup>5</sup> These fibulae are, in her opinion, characteristic of the site of Vinica and show Vinica’s influence on the La Tène culture of Dolenjska, an opinion that I shared in 2001.<sup>6</sup> In the La Tène period the area of Dolenjska belonged to the Mokronog group, which is usually attributed to the Taurisci.<sup>7</sup>

Teržan divided the group of fibulae with a rhomboidal bow below the spring into two variants: a typologically older variant of Early La Tène construction which occurs at Vinica only, and a later variant of Middle La Tène construction known, in addition to Vinica, at Lika in Croatia, in Dolenjska (Lower Carniola) and Gorenjska (Upper Carniola) in Slovenia and even in Carinthia in Austria (Fig. 1/c1). The only specimen assigned by her

1. MAHR 1934, Pls. 16/83, 18/99 and 20/115, 116.

2. DULAR 1985, 106–107 and Fig. 103. – POLIZZOTTI GREIS 2005, 25–28.

3. VOGT 1934.

4. BOŽIČ 1999, 191 and Fig. 1; 201–202.

5. TERŽAN 1975, 687, Note 92; 696, Pl. 5/5 and Map 2.

6. BOŽIČ 2001, 190, 197 left column.

7. BOŽIČ 1987, 855. – BOŽIČ 1999, 192.

to the older variant, and which had been published by Stane Gabrovec as early as 1966 (Fig. 1/c2),<sup>8</sup> however clearly exhibits a remnant of a collar attaching the foot to the bow (*Fußklammer*); hence it is also of Middle La Tène construction.

### *The cemetery of Zvonimirovo in the Croatian Drava region*

Significant insights into the fibulae of the Zvonimirovo type are owed to Marko Dizdar (Zagreb) who led the excavations of the cemetery of Veliko polje near Zvonimirovo in the vicinity of Suhopolje in the Middle Drava Valley in northern Croatia. By 2013 the excavations, which have been ongoing almost without interruption since 1992, had uncovered 101 graves; all, bar one, belong to the LT C2 phase.<sup>9</sup> Dizdar's two excavation reports of 2006 drew attention, in discussions of the female grave LT 67, to a larger bronze fibula of Middle La Tène construction, which has a large, decorated knob, flattened on the underside, and a ribbed collar, decorated with a V-pattern, on the bent-back foot.<sup>10</sup> The bow widens towards the spring, the latter consisting of eight coils and an external cord. Similar fibulae, both complete and fragmented, have been found in other female graves at Zvonimirovo (Fig. 1/b).

Dizdar considers that another bronze fibula from an uncertain grave in Brstje near Ptuj in the Slovenian Drava Valley belongs to the same form (Fig. 1/a). He mentions that I dated this grave on two occasions to the Mokronog IIa phase, which corresponds to LT C1 in central Europe,<sup>11</sup> whereas the Zvonimirovo graves containing this type of fibulae are dated to LT C2. Because several specimens were present in closed grave groups at Zvonimirovo, Dizdar called this kind of Middle La Tène bronze fibulae "fibula of the Zvonimirovo type".<sup>12</sup> In his opinion the presence of this type of fibulae confirms the supposition of connections between the sites of the Mokronog group in the Slovenian and in the central Croatian Drava regions.

A female grave (LT 68), excavated at Zvonimirovo in 2007, contained three bronze fibulae of Middle La Tène construction, of which one was of the Zvonimirovo type (as defined by Dizdar) and one of a type defined by Teržan as fibula with a rhomboidal head plate (Fig. 1/c).<sup>13</sup>

Dizdar reports that both forms occur in the southeastern Alpine zone, especially among the Taurisci, and that Zvonimirovo lies at the easternmost margin of the distribution of both types. The excavations in Zvonimirovo in the following years have yielded further specimens of the two types.<sup>14</sup> Dizdar considered both types in some greater depth in two papers, first in a discussion of the three-part iron chain belts of the Zvonimirovo LT 6 type,<sup>15</sup> and then in an overview of the La Tène culture in central Croatia.<sup>16</sup> With respect to the group of fibulae with decorated rhomboidal or, as correctly described by him, oval heads, Dizdar reiterated Teržan's (in my opinion erroneous) view that two variants exist, i.e. fibulae of Early La Tène and Middle La Tène construction.<sup>17</sup> Indeed he too had not noticed that the fibula from Golek pri Vinici (Fig. 1/c2), thought by Teržan to represent an early variant, actually possessed the usual collar. We shall see that this fibula belongs to variant c2, which in fact postdates the other three variants. *Contra* Teržan's opinion that the fibulae with rhomboidal head plates are characteristic of the Vinica group, he states that these fibulae are a feature not only of the Vinica group but also of the Mokronog group, both part of the southeastern Alpine area.

### *A fibula from the Adriatic coast*

In her dissertation submitted in 2010 to the University of Ljubljana Martina Blečić Kavur identifies an unpublished fibula with a rhomboidal head from the cemetery of Sarazinovo near Bakar on the northern coast of the Kvarner gulf as belonging to the (in my view non-existent) variant I, i.e. the variant characterised by having the foot not connected to the bow (Fig. 1/c2).<sup>18</sup> Yet the Bakar fibula and the other specimens cited by Blečić Kavur (from Golek pri Vinici and Valična vas) and considered representative of "variant I" all have a foot clamp. Blečić Kavur's distribution map<sup>19</sup> too makes a (to my mind erroneous) distinction between the earlier (square symbol) and later (circle) forms. In her opinion, only some fibulae from Golek pri Vinici and the fibula from Bakar should belong to the earlier form. Nonetheless Blečić Kavur explicitly and correctly states in her catalogue entry that the Bakar fibula is a bronze fibula of Middle La Tène construction (!) with rhomboidal

8. GABROVEC 1966b, Pl. 16/5.

9. DIZDAR 2013, 18, 369.

10. DIZDAR 2006, 106. – DIZDAR 2007b, 36–37 and Fig. 3.

11. BOŽIČ 1987, 872, 874, phase Mokronog II A and Fig. 44/10. – BOŽIČ 1999, 196–197, Mokronog IIa.

12. DIZDAR 2007b, 37.

13. DIZDAR 2007a, 129 with figure. – DIZDAR 2008, 44–45 and Fig. 2.

14. DIZDAR 2009a, 51–52.

15. DIZDAR 2009b, 281–283, 297 and Figs. 2–3.

16. DIZDAR 2011, 112–113, Figs. 3/3, 7/4 and 8/3.

17. DIZDAR 2009b, 283 and Note 23. – DIZDAR 2011, 112 right column.

18. BLEČIČ KAVUR 2010, 327–328, Figs. 246–247; 577, List 59; 449 and Pl. 20/313.

19. BLEČIČ KAVUR 2010, 328, Fig. 247.

expansion of the bow. She does not mention the fibulae with rhomboidal heads from the Zvonimirovo graves, nor Dizdar's remarks concerning them, probably because he did not illustrate any, though he provided clear descriptions in his papers.

#### *A monograph about Zvonimirovo*

The most recent treatment of Zvonimirovo type fibulae can be found in Dizdar's volume devoted to part of the graves in the cemetery of Veliko polje near Zvonimirovo, which was published in Zagreb at the end of 2013.<sup>20</sup> In this case too, the author attributed to the Zvonimirovo type only the fibulae that have a wire bow or a bow slightly widened below the spring, but not those with rhomboidal or oval head plates. As mentioned earlier, he first assigned only a few fibulae from Zvonimirovo and the fibula from Brstje (Fig. 1/a) to the Zvonimirovo type. Having presumably become acquainted with this author's communication to the conference "Boii – Taurisci" held in Oberleis-Klement in June 2012, Dizdar refers in his 2013 book for the first time to some specimens of fibulae mentioned in my communication: those from Graz-Straßgang in Styria, Zohor in Slovakia and Magdalensberg in Carinthia. Infelicitously (in my view) he believes that this form can be subdivided into three variants according to the cross section of the bow (circular, oval or strap-shaped). Although he mentions my classification into variants a, b, and c in a footnote,<sup>21</sup> he introduces a new term: "bronze fibulae of the Zvonimirovo LT 5 type". On quite unconvincing grounds he attributes both the fibulae of my variant a (Fig. 1/a) which have a wire bow (Magdalensberg, Graz and Brstje) and those of my variant b (Fig. 1/b) which have a slightly widened undecorated upper bow (Zvonimirovo and Zohor) to this new type.

#### *Typological classification (Fig. 1)*

It seems reasonable to me to assign to the Zvonimirovo type not only the fibulae which Dizdar first called Zvonimirovo type fibulae and later Zvonimirovo LT5 type – represented by several specimens from Zvonimirovo (e.g. from Graves LT 5, LT 67 and LT 68), by the fibula from Zohor in Slovakia and the fibula from Brstje near Ptuj in Slovenia – but also the fibulae that Teržan called fibulae of Middle La Tène construction with rhomboidal expansion of the bow. Both groups have very similar foot knobs and collars. The shape of the bow suggests a subdivision into three variants (a, b and c). Variant c can be further subdivided into variants c1 and c2.

20. DIZDAR 2013, 241–245 and Figs. 85–86, Map 23 (map legend on p. 478); 373 and Fig. 148; 399–402, Pls. 11/4 and 13/3.

21. DIZDAR 2013, 242, Note 122.

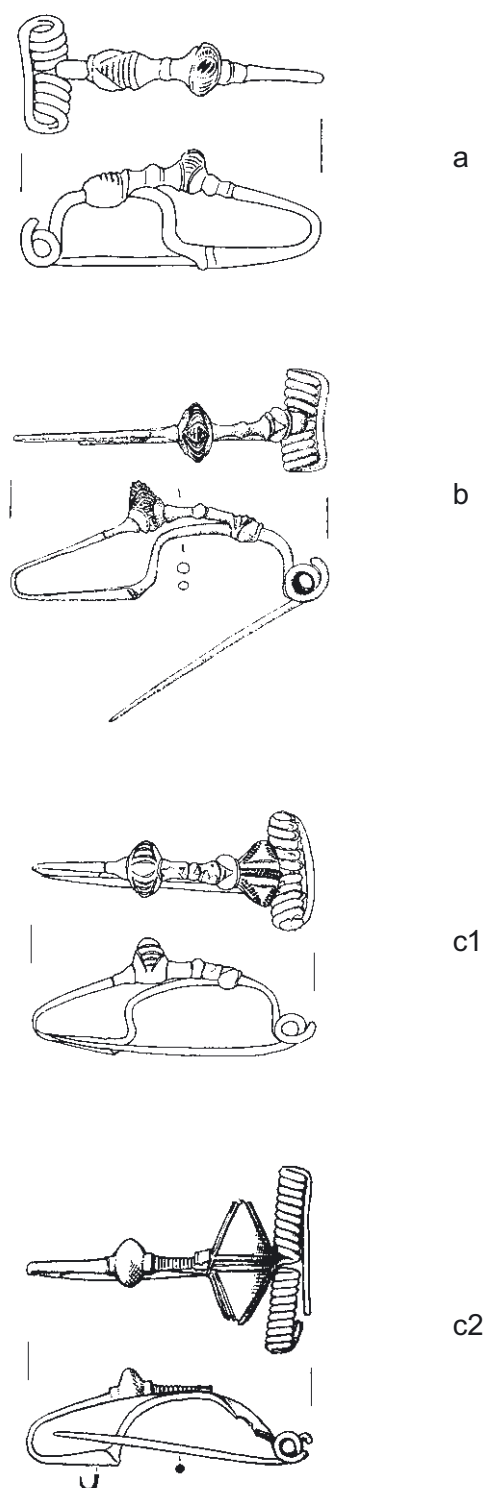

Fig. 1. Typological classification of the fibulae of the Zvonimirovo type. – a: Brstje (after GUŠTIN 1977). – b: Zvonimirovo grave LT 5 (after DIZDAR 2013). – c1: Unknown site (after GABROVEC 1966a). – c2: Golek pri Vinici (after GABROVEC 1966b).

Variants a, b and c1 have a large, massive knob, semi-oval in cross section, located on the bent-back foot. Each of its lateral surfaces is mostly decorated with a ladder motif that tapers concavely downwards or more rarely retains its width; on the crest in particular there is an oval or rhomboidal field, either cross-hatched or left empty. Among the many fibulae from Golek pri Vinici in particular, the decoration of the knob can be more ornate and can deviate from this description.<sup>22</sup> The collar is predominantly large and has convex edges. In most cases a cross-hatched triangle oriented towards the spring is located between two transverse ribs. There is usually a wide bulge between the knob and the collar.

By contrast the fibulae of variant c2 have a smaller, lower, undecorated knob, flattened at the base, which is often framed by two transverse ribs. In a few cases the bridge between the knob and the collar exhibits dense transverse incisions. The collar is small, undecorated and has only two transverse ribs.

The spring of Zvonimirovo type fibulae can be short (with 8 to 10 coils) or long.

#### *Variant a*

Fibulae of this variant have an undecorated wire bow. The spring usually consists of 8 coils but can exceptionally be longer.

#### *Variant b*

Fibulae of this variant have an undecorated bow that widens slightly below the spring. The spring usually consists of 8 coils, rarely 10.

#### *Variant c*

Fibulae of this variant have a rhomboidal or oval head plate, decorated in a variety of ways. The spring can be short or long.

### Dating

#### *The uncertain female grave of Brstje near Ptuj*

Grave 1 at Brstje near Ptuj,<sup>23</sup> presented by Mitja Guštin in 1977 as one grave group, was assigned by me to the Mokronog IIa phase, i.e. LT C1 on two occasions,<sup>24</sup>

and this has been repeatedly cited by Dizdar.<sup>25</sup> However, neither Guštin, nor Dizdar, nor I have thoroughly checked the circumstances of discovery. The grave group presented by Guštin is not secure. Indeed Stanko Pahič reports that several cremation burials were found when a gravel quarry near Brstje was extended in 1959 and that the majority of the finds that were handed to the museum in Ptuj (a bronze fibula which I identify as belonging to the Zvonimirovo type, variant a [Fig. 1/a], a richly decorated bronze chain belt and a fragment of a further chain belt,<sup>26</sup> a solid bronze bracelet with a knob, fragments of a sword blade and of a spearhead, and an iron button) are merely presumed to have been found together at a depth of 1.5 m, while two finger rings made of blue glass were found nearby.<sup>27</sup> It is therefore far from certain that the weapons and all bronze items of personal adornment belonged to the same grave group. In 1977 Guštin has nevertheless attributed all the bronze jewellery and even the two glass finger rings (which, according to the meagre and uncertain information available, were not found with the other artefacts) to a single female grave (Grave 1). It is in this guise that the grave appears in Dizdar's 2013 volume: "Grave from Brstje".<sup>28</sup>

Taking the information about the circumstances of discovery and the current state of knowledge into consideration, I believe that the solid bronze bracelet is unlikely to have come from the same grave as the fibula. The former is older and appears in female graves of LT C1.<sup>29</sup> But the bronze chain belt and the fibula could certainly have belonged to the same burial. The Brstje chain belt consists of 19 rings, 12 profiled rod-shaped links, three decorated rectangular plate links and a terminal element on one end, and two connecting links, an intermediate hook and a terminal hook (both hooks ending in an animal head) at the other; all these four elements have in their centre a rectangle, split diagonally, and filled with red enamel. The belt resembles closely the chain belts found in two southern Bavarian graves, Grave 37 at Manching-Steinbichl and Grave 2 at München-Moosach.<sup>30</sup> The completely preserved Manching belt

22. E.g. MAHR 1934, Pls. 16/83, 18/99 and 20/115. – GABROVEC 1966b, Pl. 31/7, 8. – DOBIAT 1982, Pl. 7/3.

23. GUŠTIN 1977, 71, Stopnja 3, Fig. 2/Phase 3; 79, Phase 3; 83 and Pl. 15.

24. BOŽIČ 1987, 872, phase Mokronog II A. – BOŽIČ 1999, 196, Mokronog IIa.

25. E.g. DIZDAR 2006, 106. – DIZDAR 2009b, 282, 283 and Fig. 3; 297. – DIZDAR 2013, 242, Note 123 and Fig. 86.

26. PAHIČ 1966, 288, Note 86 and Pl. 1/6.

27. PAHIČ 1966, 305–306, No. 2 and Pl. 1.

28. DIZDAR 2013, 242 and Fig. 86.

29. BOŽIČ 1999, 197, Mokronog IIa: "solid bronze bracelets with knob". – LUBŠINA TUŠEK, KAVUR 2011, 36–37: "massive bronze bracelets with a single knob." Bracelets that do not have a knob but merely a thickening, are even older, i.e. LT B2 (LUBŠINA TUŠEK, KAVUR 2011, 36, Grave 4, No. 10 and Fig. 5/10).

30. KRÄMER 1985, 88, Grave 37, bronze chain belt and Pl. 23/1; 119, Grave 2, bronze chain belt and Pl. 56/5.



only has profiled rod-shaped links in addition to the terminal element, and at the other end a succession of an intermediate hook, a connecting link, and a terminal hook. The terminal element and the connecting link are cruciform, and the hooks have a cruciform upper part. All these four elements contain, in the centre of the cross, a diagonally split square filled with red enamel. The presence of a bronze fibula of the Mötschwil type, a glass bracelet of Gebhard's series 25 and another of series 20 suggests a date of LT C2 for both southern Bavarian graves.<sup>31</sup>

### *Zvonimirovo*

The date suggested by the southern Bavarian graves perfectly corresponds to the date for the fibulae of variants b and c1 of the Zvonimirovo type (Fig. 1) found at the cemetery of Zvonimirovo. This cemetery's 101 graves can all, bar one, be dated to the LT C2 phase (Figs. 2–3).<sup>32</sup> The graves of Mihovo and Golek pri Vinici must be left out of the argument because it is uncertain whether they are closed assemblages. We can conclude that variants a, b and c1 can be dated to the later part of the Middle La Tène, i.e. LT C2.

### *A more recent variant*

It is likely that the fibulae of variant c2 (Fig. 1) are more recent, most probably dating to LT D1, and this for two reasons. The fibula from the cemetery of Strmec above Bela Cerkev belongs to a group of finds which, among others, contained a shield boss of the Mokronog-Arquà Petrarca type<sup>33</sup> and a pair of bronze fibulae with enamelled plates;<sup>34</sup> the greatest probability is that it dates to LT D1. Moreover some fibulae of variant c2 from Golek pri Vinici possess a low knob framed by two transverse ribs and a bridge between the knob and the clamp decorated with dense transverse incisions (Fig. 1/c2),<sup>35</sup> which closely resemble the features on some fibulae of the Ribić variant of the Kastav type.<sup>36</sup> Two graves in the Una Valley in Bosnia date the Ribić variant into the Late La Tène period.<sup>37</sup>

### **Distribution (Fig. 4)**

#### *Taurisci*

The fibulae of the Zvonimirovo type are relatively frequent in two Tauriscan cemeteries, at Mihovo at the foot of the Gorjanci Mountain and in Zvonimirovo in the Croatian Drava Valley, one of the easternmost sites of the La Tène Mokronog group, usually attributed to the Celtic Taurisci. Two specimens, found in the largest cemetery of this group, at Kapiteljska njiva near Novo Mesto, which so far has yielded over 700 cremation burials, have been published to date. Individual specimens are also known from two further cemeteries of the Mokronog group, at Valična vas in the Krka Valley and Brstje in the Drava Valley.

#### *Norici and Boii*

The fibulae from Klagenfurt/Celovec and Magdalensberg show that fibulae of the Zvonimirovo type are also known in the region occupied by the Norici in present-day Carinthia.

The well-preserved fibula from Zohor in Slovakia is the northernmost specimen known to date; it most probably indicates that contacts existed between the Boii and the Taurisci in the LT C2 phase. Such contacts continued into the LT D1 phase, as attested by the presence of a typically Tauriscan cast bronze fibulae of the Magdalenska gora type at the oppidum of Staré Hradisko in Moravia.<sup>38</sup>

#### *Colapiani*

As mentioned, Teržan thought in 1971 that the fibulae of variant c of the Zvonimirovo type, which she called "fibulae of Middle La Tène construction with rhomboidal expansion of the bow" were typical of the Vinica group,<sup>39</sup> understandably so in the light of the state of research of the time. Thanks to the 1934 auction catalogue and Gabrovec's paper of 1966 several examples were known to have come from the cemetery of Golek pri Vinici in the Kolpa Valley, which lies at the foot of the unexplored Iron Age settlement on the Šlemine hill – presumably a central place of the Colapiani.<sup>40</sup> From all the other sites, only one specimen apiece was known. The Tauriscan cemetery of Mihovo, which has also yielded several specimens of variant c, was largely unknown at the time. Today we have a good insight into the fibulae from Golek pri Vinici, thanks to the drawings of grave goods from this site, long kept in the library of the Institute of Archaeology in Ljubljana. In addition,

31. GEBHARD 1989, 16–17, Series 20 and Series 25, 52, Grave 37, 54–55, München-Moosach and Note 178.

32. DIZDAR 2013, 18 and Note 4.

33. BOŽIČ 1999, 198, Mokronog IIIa.

34. BOŽIČ 1992, 1–11, Pls. 1 and 2/1–3. – PAVLIN 2007, 760–761 and Fig. 3/2, 3.

35. Graves 136, 210 and 278. – GABROVEC 1966b, Pl. 16/5.

36. MARIĆ 1968, Pl. 13/22, 23, 25. – GUŠTIN 1987, 50–51.

37. MARIĆ 1968, Pls. 4/6 and 13/41.

38. DIZDAR, BOŽIČ 2010, 148, Fig. 4/8a; 158, variant 8.

39. TERŽAN 1975, 687, Pl. 5/5; 696, Note 92.

40. DULAR 1985, 107–108 and Fig. 104.

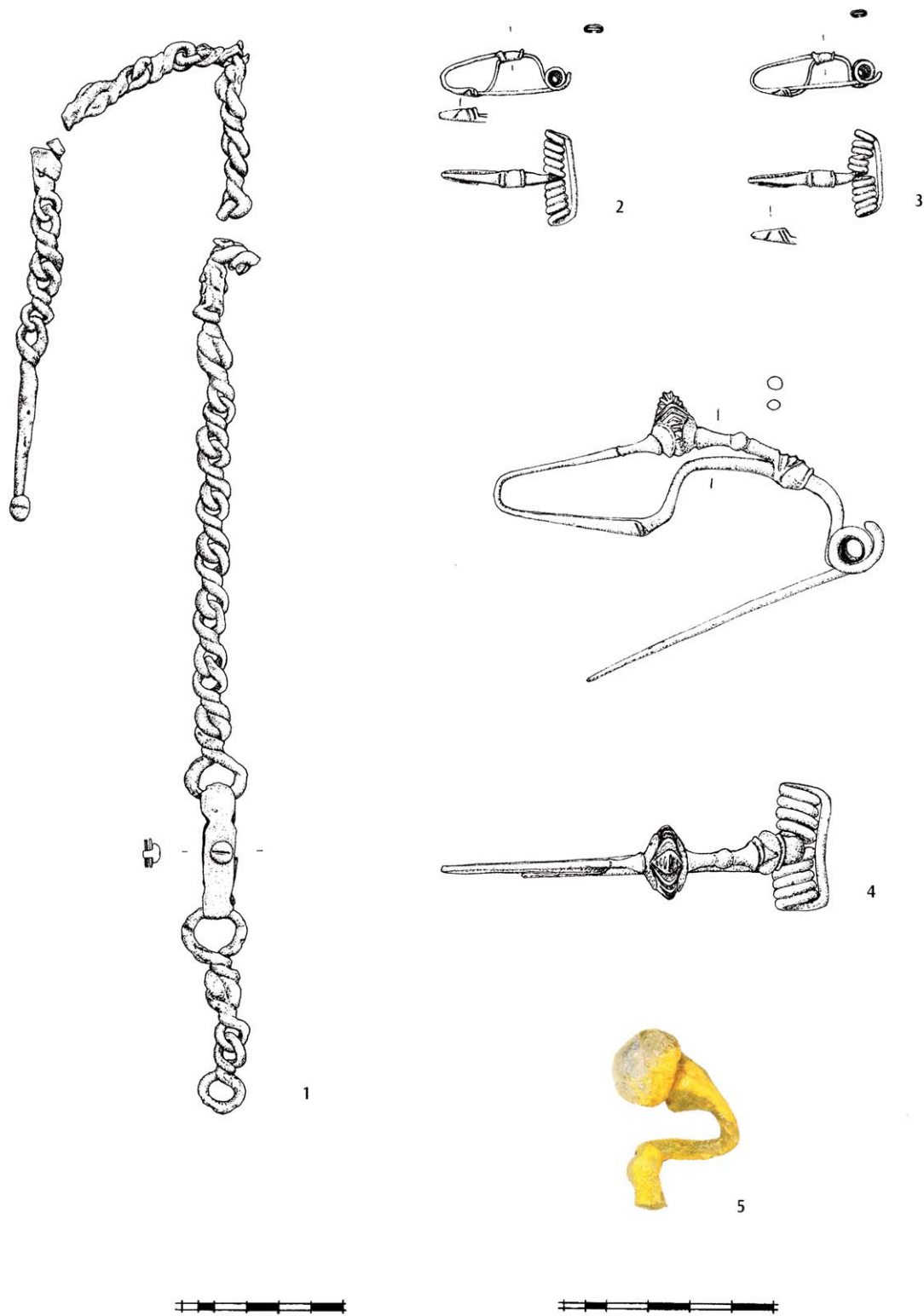

Fig. 2. Grave LT 5, Zvonimirovo in northern Croatia, part 1 (after DIZDAR 2013).

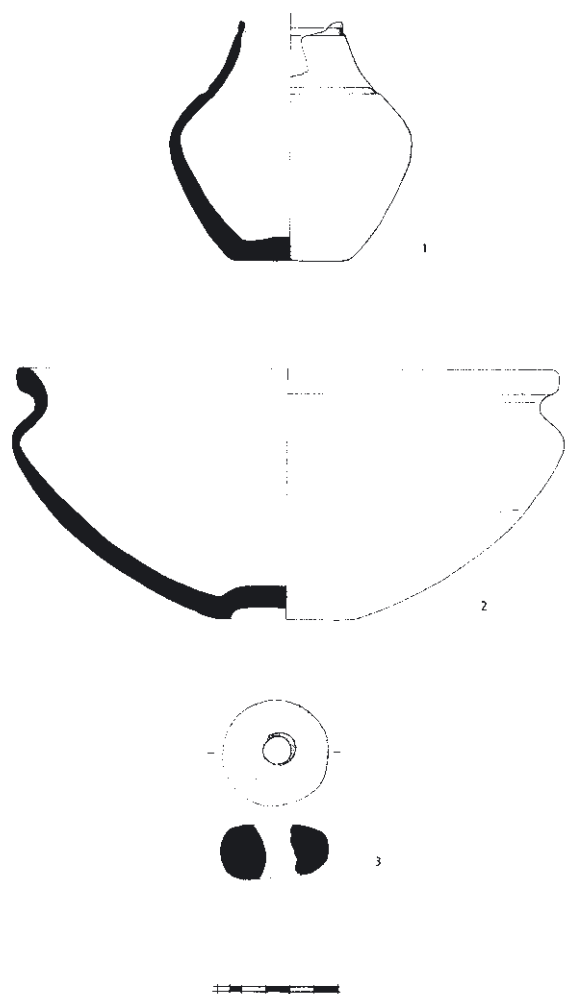

Fig. 3. Grave LT 5, Zvonimirovo in northern Croatia, part 2 (after DIZDAR 2013).

the descriptions and photographs of the finds from the cemetery located at Stražni dol near Golek pri Vinici are available on the website of the Peabody Museum of Archaeology and Ethnology at Harvard University.<sup>41</sup> The number of fibulae of the Zvonimirovo type found at that site is considerably larger than previously recorded, and all variants are represented. Surely this is owed to the large number of graves discovered in this location.

In my opinion the fibulae of the Zvonimirovo type are Celtic fibulae which were particularly prized by the population of Golek pri Vinici and, as the minute variations in the many examples found on the site show, were manufactured there. The numerous examples of the Gemeinlebarn variant of the Mötschwil type<sup>42</sup> and the

41. Peabody Museum Collections Online (<http://pmem.unix.fas.harvard.edu:8080/peabody/>), Quick search: Vinica (last access 29.01.2016).

42. Božič 1993, 198–199, Group A, No. 5 and Group B, No. 12.

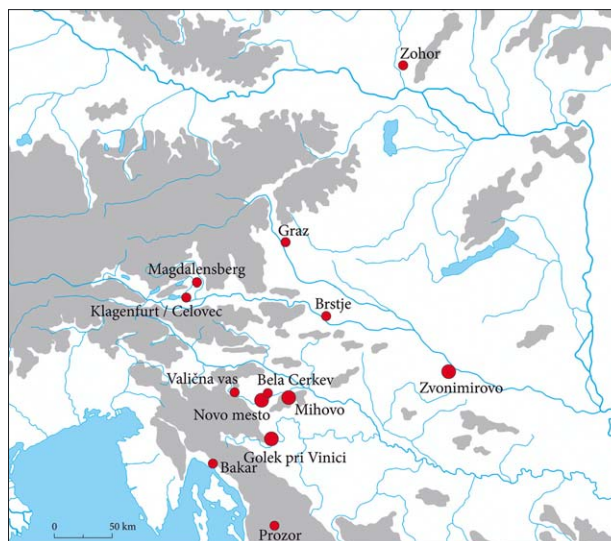

Fig. 4. Distribution of bronze fibulae of the Zvonimirovo type. Large circle: several specimens.

Valična vas type<sup>43</sup> indicate that Celtic fibulae for costumes were a dominant trait at Golek pri Vinici during LT C2. This would also explain the almost total absence of Zvonimirovo type fibulae among the Japodes in Lika in Croatia and in the Una Valley in Bosnia. The Celtic fibulae of the Gemeinlebarn variant of the Mötschwil type and those of the Valična vas type did however reach the region occupied by the Colapiani, but not that of the Japodes.

The distribution of the later variant c2 of the Zvonimirovo type, dated to LT D1, is confined to the Krka Valley (Bela Cerkev), the Kolpa Valley (Golek pri Vinici) and the Adriatic coast (Bakar). The late date suggested for this variant is supported by the fact that it is absent from Zvonimirovo whose burials end at the end of LT C2.

## Conclusion

### *Fibulae of the Zvonimirovo type, Gemeinlebarn variant of the Mötschwil type and the Valična vas type*

The three older variants of Zvonimirovo type bronze fibulae (a, b, and c1), which all have a large decorated knob but a differentially-shaped bow (Fig. 1), represent an element of the female attire of the Taurisci in the LT C2 phase. Isolated specimens have come to light in the region occupied by the Norici in Carinthia, and even one specimen has come from the area occupied by the Boii in Slovakia. Such fibulae were also adopted under Tauriscan influence as part of the traditional women's attire of the Colapiani; there they appear to have been produced locally and are even more richly ornamented than those

43. Graves 40, 131, 195, etc.



Fig. 5. Bronze fibula of the Ljubljana type from Vrtičnik above Tupaliče in Gorenjska. Length: 4.5 cm (Gorenjski muzej in Kranj, Inv. no. A 2893).

of the Taurisci. The fourth variant (c2), assigned to LT D1, seems to have developed among the Colapiani in part under the influence of fibulae of the Ribič variant of the Kastav type that is typical of the Japodes<sup>44</sup> and Liburni.<sup>45</sup>

Two further forms of bronze fibulae prized among Tauriscan women of the LT C2 phase have a similar distribution, ranging from the area occupied by the Boii to that of the Colapiani: they are the fibulae of the Gemeinlebern variant of the Mötschwil type<sup>46</sup> and fibulae of the Valična vas type.<sup>47</sup>

#### *Fibulae of Middle La Tène construction of the Ljubljana type*

The fibulae of Middle La Tène construction of the Ljubljana type (Fig. 5)<sup>48</sup> are a further form of fibula, but they can only be attributed to the LT C2 phase on typological grounds. They usually have two parallel lines running along the head, and deep grooves radially arranged along the edges. They appear to be typical of the western Tau-

riscan region. The term Ljubljana type is justified by the fact that most examples of this type, unpublished so far, have been found in Ljubljana: one such fibula came to light in Dvorišče SAZU (Academy Courtyard) on the left bank of the Ljubljanica and several others on the site of Tribuna in the Prule area on the right bank of the river. Only a few bronze fibulae of the Ljubljana type have been found outside the area occupied by the Taurisci: at Gurina in the upper Gail Valley in Carinthia,<sup>49</sup> in Linz on the Danube<sup>50</sup> and even on the oppidum of Třísov<sup>51</sup> in the territory of the Boii in Bohemia.

The above mentioned fibulae found in the territory of the Boii, which are most likely to have originated in the south, are testimony, at least in part, of an export of goods from the area occupied by the Taurisci towards the north, into the regions bordering the Danube and further north, or they represent the influence exerted by Tauriscan forms on workshops in the Danube zone and beyond.

44. GUŠTIN 1987, 50–51 and Fig. 11/Ribič variant.

45. BATOVIĆ, BATOVIĆ 2013, Pl. 18/49–55; Pl. 19/56.

46. BOŽIČ 1993, 196–200, 203 and Fig. 4/2–4. – NEUGEBAUER 1993, 105, figure bottom right. – ČIŽMÁŘ 2001, 299, No. 8 and Fig. 1/8 (Břeclav-Pohansko). – ČIŽMÁŘ 2002, 214, 223 and Fig. 12/1; Fig. 13.

47. WALLNER 1991, 217, Fig. 621 (Roseldorf). – LAZAR 1996, 279–280, Pl. 1/1–4. – JANDRASITS 1999, 738, Fig. 416 (Roseldorf). – ČIŽMÁŘ, KOLNÍKOVÁ 2006, 262, Fig. 1/7. – CUNJA, MLINAR 2010, 47–48, 112, Cat. no. 113.

48. DANIELISOVÁ, MILITKÝ 2014, 45, Note 3; 65 and Fig. 2a/4.

49. JABLONKA 2001, 116, fibula with triangular flat bow and Pl. 81/18 (in my view the identification and dating are incorrect).

50. TREBSCHKE 2001, 24, 61, bronze fragment and Fig. 7/61.

51. DANIELISOVÁ, MILITKÝ 2014, 43, 45, 65, Tabs. 1/4 and 2/4, Figs. 2a/4 and 4/Ljubljana.

**List****Fibulae of the Zvonimirovo type (Figs. 1 and 4)***Variant a*

1. Brstje  
MIKL 1960, 327. – PAHIČ 1966, 306, No. 1, Pl. 1/7. – GUŠTIN 1977, 83, Pl. 15/1.
2. Golek pri Vinici, Graves 116 and 163  
GABROVEC 1966b, Pl. 15/7.
3. Graz-Straßgang  
KRAMER 1994, 29, Note 89; 62, No. 83, Pl. 61/2.
4. Magdalensberg  
SEDLMAYER 2009, 13, No. 2.2; 180, Fig. 118/2; 232, Pl. 1/2.

*Variant b*

1. Golek pri Vinici, Graves 23 and 77
2. Novo Mesto-Kapiteljska njiva, Grave 183  
KRIŽ 2005, 78, Pl. 52/Grave 183/2.
3. Zohor  
ELSCHEK 2011a, 12 and figure. – ELSCHEK 2011b, 85 and Fig. 23/6.
4. Zvonimirovo, Graves LT 5, LT 6, LT 67 and LT 68  
DIZDAR 2007a, 129 and figure. – DIZDAR 2007b, 36, Fig. 3. – DIZDAR 2008, 44, Fig. 2. – DIZDAR 2009b, 282, Fig. 2. – DIZDAR 2011, 112, Figs. 3/3, 7/4 and 8/3. – DIZDAR 2013, 399–400, No. 2, Pl. 11/4; 402, No. 3, Pl. 13/3.

*Variant c1*

1. Golek pri Vinici, Graves 5, 10, 24, 35, 60, 98a, 132, 136, 174, 196, 219, 251 and 252  
MAHR 1934, 96, Lot 83, Grave 174, Pl. 16; 101, Lot 99, Grave 251, Pl. 18; 107, Lot 115, single find, Pl. 20; 107, Lot 116, single find, Pl. 20. – GABROVEC 1966b, Pls. 16/3 and 31/7, 8. – DOBIAT 1982, Pl. 7/3, 4, 8.
2. Klagenfurt/Celovec – Dr.-Richard-Canaval-Gasse  
DOLENZ 1957, 46–47, No. 5, Fig. 3.
3. Mihovo, Graves 1655/44, 1657/38, 1657/40, 1657/55, 1657B/72 and 1663/location of sword 7  
WINDL 1975, 267 (fibulae with rhomboidal sheet bows and strongly profiled feet), Pls. 6/17, 36/11, 37/2, 41/12, 54/7 and 76/15.
4. Novo Mesto-Kandija  
KNEZ 1966, 399, Pl. 7/1.
5. Novo Mesto-Kapiteljska njiva, Grave 567  
KRIŽ 2001, 136, No. 372.
6. Prozor in Lika  
TODOROVIĆ 1968, Pl. 59/7.
7. Valična vas  
GABROVEC 1966b, Pl. 25/9. – TERŽAN 1975, 667, No.

46, Pl. 5/5.

8. Zvonimirovo, Grave LT 68  
DIZDAR 2008, 44.
9. Unknown site  
GABROVEC 1966a, 103, No. 5, Note 51, Pl. 11/3.

*Variant c2*

1. Bakar-Sarazinovo  
BLEČIĆ KAVUR 2010, 327–328, 448–449, No. 313, Fig. 246/2, Pl. 20/313 (attributed to the non-existent variant I of fibulae with rhomboidal expansions of the bow).
2. Bela Cerkev-Strmec  
STARE 1973, 43, No. 971, Pl. 54/3.
3. Golek pri Vinici, Graves 130, 133, 136, 210 and 278.  
GABROVEC 1966b, Pl. 16/5, 6.

**Acknowledgements**

My heartfelt thanks go to my colleagues Verena Perko, curator at the Gorenjski muzej in Kranj for sending me the photographs of the Ljubljana type fibula from Vrtničnik above Tupaliče, and Drago Valoh and Mateja Belak for making the illustrations.

**References**

- BATOVIĆ, BATOVIĆ 2013
- A. BATOVIĆ, Š. BATOVIĆ, Helenistički grobovi iz Nadina u okviru V. (zadnje) faze liburnske kulture: građa za povijest Liburna, IV.-I. st. prije Krista, Posebna izdanja / Arheološki muzej Zadar 2, 2013.
- BLEČIĆ KAVUR 2010
- M. BLEČIĆ KAVUR, Željezno doba na Kvarneru. Unpublished PhD Dissertation, University of Ljubljana 2010.
- BOŽIČ 1987
- D. BOŽIČ, Keltska kultura u Jugoslaviji: zapadna grupa. In: S. GABROVEC (Ed.), Praistorija jugoslavenskih zemalja 5. Željezno doba, Sarajevo 1987, 855–897.
- BOŽIČ 1992
- D. BOŽIČ, Mokronoška skupina latenske kulture v poznolatenskem obdobju. Unpublished PhD Dissertation, University of Ljubljana 1992.
- BOŽIČ 1993
- D. BOŽIČ, O latenskih najdbah na območju Ptujja. In: B. LAMUT (Ed.), Ptujski arheološki zbornik ob 100-letnici muzeja in Muzejskega društva. Ptuj 1993, 189–204.
- BOŽIČ 1999
- D. BOŽIČ, Die Erforschung der Latènezeit in Slowenien seit Jahr 1964, Arheološki vestnik 50, 1999, 189–213.
- BOŽIČ 2001
- D. BOŽIČ, Ljudje ob Krki in Kolpi v latenski dobi, Arheološki vestnik 52, 2001, 181–198.



- CUNJA, MLINAR 2010  
R. CUNJA, M. MLINAR (Eds.), *S fibulo v fabulo: fibule iz Istre, s Krasa, iz Notranjske in Posočja med prazgodovino in zgodnjim srednjim vekom*. Koper 2010.
- ČIŽMÁŘ 2001  
M. ČIŽMÁŘ, *K laténskému osídlení Pohanska u Břeclavi*. In: V. PODBORSKÝ (Ed.), *50 let archeologických výzkumů Masarykovy univerzity na Znojemsku*. Brno 2001, 295–299.
- ČIŽMÁŘ 2002  
M. ČIŽMÁŘ, *Laténský depot ze Ptení – k poznání kontaktů našeho území s jihem*, *Památky archeologické* 93/2, 194–225.
- ČIŽMÁŘ, KOLNÍKOVÁ 2006  
M. ČIŽMÁŘ, E. KOLNÍKOVÁ, *Němčice – obchodní a industriální centrum doby laténské na Moravě*, *Archeologické rozhledy* 58/2, 2006, 261–283.
- DANIELISOVÁ, MILITKÝ 2014  
A. DANIELISOVÁ, J. MILITKÝ, *Pozdně laténské spony z oppida Třísov, získané povrchovou prospekci v letech 2008–2013*, *Archeologické rozhledy* 66, 2014, 40–66.
- DIZDAR 2006  
M. DIZDAR, *Lokalitet: Zvonimirovo – Veliko polje*, *Hrvatski arheološki godišnjak* 3, 2006, 105–107.
- DIZDAR 2007a  
M. DIZDAR, *Lokalitet: Zvonimirovo – Veliko polje*, *Hrvatski arheološki godišnjak* 4, 2007, 128–129.
- DIZDAR 2007b  
M. DIZDAR, *Rezultati istraživanja groblja na Velikom polju u Zvonimirovu 2006. godine*, *Annales Instituti Archaeologici* 3, 2007, 34–37.
- DIZDAR 2008  
M. DIZDAR, *Rezultati istraživanja groblja na Velikom polju u Zvonimirovu 2007. godine*, *Annales Instituti Archaeologici* 4, 2008, 44–45.
- DIZDAR 2009a  
M. DIZDAR, *Rezultati istraživanja groblja latenske kulture Zvonimirovo-Veliko polje u 2008. g.*, *Annales Instituti Archaeologici* 5, 2009, 51–53.
- DIZDAR 2009b  
M. DIZDAR, *Željezni pojasi tipa Zvonimirovo LT 6 kao dio ženske srednjelatenske nošnje u zapadnoj Panoniji i na jugoistočnoalpskom prostoru*, *Vjesnik Arheološkog muzeja u Zagrebu* 42, 2009, 271–304.
- DIZDAR 2011  
M. DIZDAR, *The La Tène culture in central Croatia: the problem of the eastern border of the Taurisci in the Podravina region*. In: M. GUŠTIN, M. JEVTIĆ (Eds.), *The Eastern Celts: The Communities between the Alps and the Black Sea*. Koper – Belgrade 2011, 99–118.
- DIZDAR 2013  
M. DIZDAR, *Zvonimirovo Veliko polje: groblje latenske kulture 1*. *Monographiae Instituti Archaeologici* 8, Zagreb 2013.
- DIZDAR, BOŽIČ 2010  
M. DIZDAR, D. BOŽIČ, *O nekim oblicima fibula s kasno-latenskog naselja Virovitica – Kiškorija sjever*, *Prilozi Instituta za arheologiju u Zagrebu* 27, 2010, 145–160.
- DOBIAT 1982  
C. DOBIAT, *Funde aus der Sammlung Mecklenburg. Kleine Schriften aus dem Vorgeschichtlichen Seminar Marburg* 12, Marburg 1982.
- DOLENZ 1957  
H. DOLENZ, *Neue Mittel-La-Tène-Funde aus Kärnten, Carinthia I* 147, 1957, 43–59.
- DULAR 1985  
J. DULAR, *Arheološka topografija Slovenije. Topografsko področje XI (Bela krajina)*, Ljubljana 1985.
- ELSCHEK 2011a  
K. ELSCHKEK, *Kniežací hrob z rímskej doby v Zohore*, *Pamiatky a múzeá* 60, 2011, 8–13.
- ELSCHEK 2011b  
K. ELSCHKEK, *Vel'koplošný záchranný výskum v areáli A.S.A. Zohor*, *Archeologické výskumi a nálezy na Slovensku v roku 2008, 2011*, 85–87.
- GABROVEC 1966a  
S. GABROVEC, *Kamniško ozemlje v prazgodovini*, *Kamniški zbornik* 10, 1966, 89–134.
- GABROVEC 1966b  
S. GABROVEC, *Srednjelatensko obdobje v Sloveniji*, *Arheološki vestnik* 17, 1966, 169–242.
- GEBHARD 1989  
R. GEBHARD, *Der Glasschmuck aus dem Oppidum von Manching. Die Ausgrabungen in Manching* 11, Stuttgart 1989.
- GUŠTIN 1977  
M. GUŠTIN, *Relativna kronologija grobov "Mokronoške skupine"*. In: M. GUŠTIN (Ed.), *Keltske študije. Posavski muzej Brežice* 4, Brežice 1977, 67–103.
- GUŠTIN 1987  
M. GUŠTIN, *La Tène fibulae from Istria*, *Archaeologia Jugoslavica* 24, 1987, 43–56.
- JABLONKA 2001  
P. JABLONKA, *Die Gurina bei Dellach im Gailtal: Siedlung, Handelsplatz und Heiligtum*. *Aus Forschung und Kunst* 33, Klagenfurt 2001.
- JANDRASITS 1999  
H. JANDRASITS, *KG Roseldorf, Fundberichte aus Österreich* 37/1998, 1999, 738.
- KNEZ 1966  
T. KNEZ, *Latenske najdbe iz Novega mesta*, *Arheološki vestnik* 17, 1966, 391–407.

- KRAMER 1994  
M. KRAMER, Latènefunde der Steiermark. Kleine Schriften aus dem Vorgeschichtlichen Seminar der Philipps-Universität Marburg 43, Marburg 1994.
- KRÄMER 1985  
W. KRÄMER, Die Grabfunde von Manching und die latènezeitlichen Flachgräber in Südbayern. Die Ausgrabungen in Manching 9, Stuttgart 1985.
- KRIŽ 2001  
B. KRIŽ, Kelti v Novem mestu: katalog razstave (The Celts in Novo Mesto: Exhibition Catalogue. 30 November 2001–22 September 2002). Novo Mesto 2001.
- KRIŽ 2005  
B. KRIŽ, Novo Mesto 6, Mlajšeželeznodobno grobišče: Kapiteljska njiva, Carniola Archaeologica 6, 2005.
- LAZAR 1996  
I. LAZAR, Latènezeitliche und frühromische Funde aus der Savinja in Celje, Arheološki vestnik 47, 1996, 279–296.
- LUBŠINA TUŠEK, KAVUR 2011  
M. LUBŠINA TUŠEK, B. KAVUR, Srednica near Ptuj: a contribution to the beginning of the La Tène period in eastern Slovenia. In: M. GUŠTIN, M. JEVTIĆ (Eds.), The Eastern Celts: The Communities between the Alps and the Black Sea. Koper – Belgrade 2011, 31–50.
- MAHR 1934  
A. MAHR (Ed.), Prehistoric Grave Material from Carniola excavated in 1905–14 by H. H. the late Duchess Paul Friedrich of Mecklenburg. New York 1934.
- MARIĆ 1968  
Z. MARIĆ, Japodske nekropole v dolini Une, Glasnik Zemaljskog Muzeja Bosne i Hercegovine u Sarajevu, Arheologija 23, 1968, 5–79.
- MIKL 1960  
I. MIKL, Brestje (sic), Ptuj, Maribor, Varstvo spomenikov 7, 1960, 327.
- NEUGEBAUER 1993  
J.-W. NEUGEBAUER, Archäologie in Niederösterreich: St. Pölten und das Traisental. St. Pölten – Vienna 1993.
- PAHIČ 1966  
S. PAHIČ, Keltske najdbe v Podravju, Arheološki vestnik 17, 1966, 271–336.
- PAVLIN 2007  
P. PAVLIN, Železnodobne najdbe z Graca pri Selih pri Zajčjem Vrhu. In: M. BLEČIĆ, M. ČREŠNAR, B. HÄNSEL, A. HELLMUTH, E. KAISER, C. METZNER-NEBELSICK (Eds.), Scripta praehistorica in honorem Biba Teržan. Situla 44, Ljubljana 2007, 759–767.
- POLIZZOTTI GREIS 2005  
G. POLIZZOTTI GREIS, A Noble Pursuit: The Duchess of Mecklenburg Collection from Iron Age Slovenia. Cambridge, Mass. 2005.
- SEDLMAYER 2009  
H. SEDLMAYER, Die Fibeln vom Magdalensberg: Funde der Grabungsjahre 1948–2002 und Altfunde des 19. Jahrhunderts. Kärntner Museumsschriften 79, Klagenfurt 2009.
- STARE 1973  
V. STARE, Prazgodovina Šmarjete. Katalogi in monografije 10, Ljubljana 1973.
- TERŽAN 1975  
B. TERŽAN, Valična vas, Arheološki vestnik 24/1973, 1975, 660–729.
- TODOROVIĆ 1968  
J. TODOROVIĆ, Kelti u jugoistočnoj Evropi. Dissertationes–Arheološko društvo Jugoslavije 7, Belgrade 1968.
- TREBSCHKE 2001  
P. TREBSCHKE, Archäologische Funde aus Neubau bei Linz – Neuerwerbungen im Nordico. Linzer archäologische Forschungen Sonderheft 26, Linz 2001.
- VOGT 1934  
E. VOGT, The cemetery of Vinica (Weinitz), Carniola. In: A. MAHR (Ed.), Prehistoric Grave Material from Carniola excavated in 1905–14 by H. H. the late Duchess Paul Friedrich of Mecklenburg. New York 1934, 47–56.
- WALLNER 1991  
E. WALLNER, KG Roseldorf, Fundberichte aus Österreich 29/1990, 1991, 217.
- WINDL 1975  
H. WINDL, Das latène- und kaiserzeitliche Gräberfeld von Mihovo, Unterkrain (Dolejnsko), Unpublished PhD Dissertation, University of Vienna 1975.

*Izr. prof. dr. Dragan Božič*  
Znanstvenoraziskovalni center SAZU  
Inštitut za arheologijo  
Novi trg 2  
1000 Ljubljana  
Slovenia  
dragan.bozic@zrc-sazu.si

