

Velodyne® LiDAR PUCK™

Automotive



Mapping



UAV



Security



Robotics



Automation



Velodyne LiDAR PUCK™

VLP-16

Velodyne's new VLP-16 sensor is the smallest, newest, and most advanced product in Velodyne's 3D LiDAR product range. Vastly more cost-effective than similarly priced sensors, and developed with mass production in mind, it retains the key features of Velodyne's breakthroughs in LiDAR: Real-time, 360°, 3D distance and calibrated reflectivity measurements.

3D - Real Time - LiDAR

The VLP-16 has a range of 100m, and the sensor's low power consumption (~8W), light weight (830 grams), compact footprint (~Ø103mm x 72mm), and dual return capability make it ideal for UAVs and other mobile applications.

Velodyne's LiDAR Puck supports 16 channels, ~300,000 points/sec, a 360° horizontal field of view and a 30° vertical field of view, with +/- 15° up and down. The Velodyne LiDAR Puck does not have visible rotating parts, making it highly resilient in challenging environments (Rated IP67).



DIMENSIONS

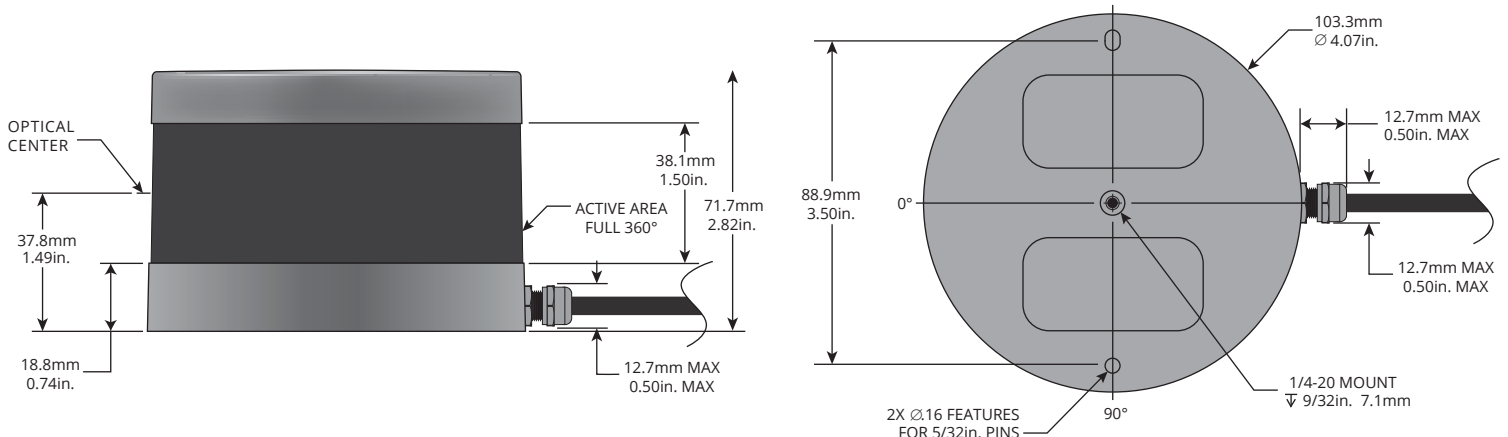

Velodyne LiDAR PUCK™

VLP-16



Specifications:

Sensor:

- Time of flight distance measurement with calibrated reflectivities
- 16 channels
- Measurement range up to 100 meters
- Accuracy: +/- 3 cm (typical)
- Dual returns
- Field of view (vertical): 30° (+15° to -15°)
- Angular resolution (vertical): 2°
- Field of view (horizontal/azimuth): 360°
- Angular resolution (horizontal/azimuth): 0.1° - 0.4°
- Rotation rate: 5 - 20 Hz
- Integrated web server for easy monitoring and configuration

Laser:

- Class 1 - eye safe
- 905 nm wavelength

Mechanical/ Electrical/ Operational

- Power consumption: 8 W (typical)
- Operating voltage: 9 - 32 VDC (with interface box and regulated power supply)
- Weight: 830 grams (without cabling)
- Dimensions: 103 mm diameter x 72 mm height
- Shock: 500 m/sec² amplitude, 11 msec duration
- Vibration: 5 Hz to 2000 Hz, 3G rms
- Environmental Protection: IP67
- Operating temperature -10° to +60° C
- Storage temperature - 40° to +105° C

Output:

- Up to 0.3 million points/second
- 100 Mbps Ethernet connection
- UDP packets containing
 - Distances
 - Calibrated reflectivities
 - Rotation angles
 - Synchronized time stamps (µs resolution)
- \$GPRMC NMEA sentence from GPS receiver (GPS not included)

Copyright ©2015 Velodyne Acoustics, Inc. Specifications are subject to change without notice.
Other trademarks or registered trademarks are property of their respective owners.
63-9229 Rev-A