

3GPP2 X.S0004-000-E

Version 1.0.0

Date: March 2004



3RD GENERATION
PARTNERSHIP
PROJECT 2
"3GPP2"

Introduction to TIA-41

COPYRIGHT

3GPP2 and its Organizational Partners claim copyright in this document and individual Organizational Partners may copyright and issue documents or standards publications in individual Organizational Partner's name based on this document. Requests for reproduction of this document should be directed to the 3GPP2 Secretariat at secretariat@3gpp2.org. Requests to reproduce individual Organizational Partner's documents should be directed to that Organizational Partner. See www.3gpp2.org for more information.

Revision History

Revision	Initial Publication	Date
Rev. 0	Initial Publication	March 2004

Contents

1		
2		
3		
4		
5		Part 000
6		
7	REVISION HISTORY	ii
8	FOREWORD	1
9		
10		
11	1 COMPARISON WITH IS-41-C/ANS-41-D	2
12		
13	2 PART STRUCTURE	8
14	2.1 OBJECTIVE.....	9
15	2.2 SCOPE	9
16	2.3 REFERENCES.....	9
17	2.3.1 Normative References.....	9
18	2.3.2 Informative References	15
19		
20		
21		
22	3 DEFINITIONS AND DOCUMENTATION CONVENTIONS	16
23	3.1 DEFINITIONS	16
24		
25	4 SYMBOLS AND ABBREVIATIONS	28
26	4.1 DOCUMENTATION CONVENTIONS	50
27	4.1.1 Scenario Diagram Conventions.....	50
28	4.1.2 Scenario Description Conventions	53
29	4.1.3 TCAP Package Type Diagram Conventions	55
30		
31		
32	5 NETWORK REFERENCE MODEL	57
33	5.1 NETWORK ENTITY RELATIONSHIP DIAGRAM.....	57
34		
35		
36	6 CELLULAR INTERSYSTEM SERVICES	58
37	6.1 GENERAL BACKGROUND AND ASSUMPTIONS	59
38	6.2 OTA ASSUMPTIONS.....	60
39	6.3 NETWORK TMSI ASSUMPTIONS.....	60
40	6.4 WIRELESS INTELLIGENT NETWORK ASSUMPTIONS.....	61
41	6.5 SEGMENTATION AND REASSEMBLY ASSUMPTIONS.....	61
42	6.6 PCS MULTI-BAND SUPPORT ASSUMPTIONS	62
43	6.7 IMSI SUPPORT ASSUMPTIONS	62
44	6.8 WIRELESS NUMBER PORTABILITY ASSUMPTIONS	64
45	6.9 CALLING NAME PRESENTATION ASSUMPTIONS	65
46	6.10 AUTHENTICATION ENHANCEMENT ASSUMPTIONS	66
47		
48		
49		
50		
51	7 RESTRICTIONS	66
52		
53		
54		
55		Part 500
56		
57	1 MAP PROTOCOL ARCHITECTURE	1
58		
59		
60		

Part 510		1
1	X.25-BASED DATA TRANSFER SERVICES.....	1
Part 511		6
1	Message Transfer Part	1
2	Signaling Connection Control Part	2
Part 512		14
1	ITU-T SS7-BASED DATA TRANSFER SERVICES.....	1
1.1	MESSAGE TRANSFER PART.....	1
1.2	SIGNALING CONNECTION CONTROL PART	2
Part 520		22
1	APPLICATION SERVICES	1
1.1	APPLICATION SERVICES ARCHITECTURE	1
1.2	APPLICATION LAYER STRUCTURE	2
1.3	TCAP FORMATS AND PROCEDURES	3
1.3.1	Transaction Portion	3
1.3.2	Component Portion	3
1.3.2.1	TCAP INVOKE Component	4
1.3.2.2	TCAP RETURN RESULT Component	6
1.3.2.3	TCAP RETURN ERROR Component	7
1.3.3	TCAP REJECT Component	11
Part 540		39
1	MAP OPERATIONS.....	1
1.1	General	1
1.2	Operation Formats.....	1
1.2.1	Parameters cross references	1
1.3	Operation Specifiers.....	1
1.3.1	Mapping of Operations onto TCAP Package Types.....	4
2	OPERATION DEFINITIONS	6
2.1	AnalyzedInformation	9
2.2	AuthenticationDirective	13
2.3	AuthenticationDirectiveForward	16
2.4	AuthenticationFailureReport	18
2.5	AuthenticationRequest	20
2.6	AuthenticationStatusReport	24

1	2.7	BaseStationChallenge	27
2	2.8	Blocking	29
3	2.9	BulkDeregistration	30
4	2.10	ChangeFacilities	31
5	2.11	ChangeService	33
6	2.12	ConnectionFailureReport	36
7	2.13	ConnectResource	37
8	2.14	CountRequest	38
9	2.15	DisconnectResource	39
10	2.16	FacilitiesDirective	40
11	2.17	FacilitiesDirective2	42
12	2.18	FacilitiesRelease	48
13	2.19	FacilitySelectedAndAvailable	49
14	2.20	FeatureRequest	52
15	2.21	FlashRequest	56
16	2.22	HandoffBack	58
17	2.23	HandoffBack2	60
18	2.24	HandoffMeasurementRequest	66
19	2.25	HandoffMeasurementRequest2	68
20	2.26	HandoffToThird	70
21	2.27	HandoffToThird2	72
22	2.28	InformationDirective	77
23	2.29	InformationForward	79
24	2.30	InstructionRequest	81
25	2.31	InterSystemAnswer	82
26	2.32	InterSystemPage	83
27	2.33	InterSystemPage2	87
28	2.34	InterSystemSetup	91
29	2.35	LocationRequest	93
30	2.36	MessageDirective	97
31	2.37	MobileOnChannel	98
32	2.38	Modify	99
33	2.39	MSInactive	100
34	2.40	NumberPortabilityRequest	102
35	2.41	OriginationRequest	103
36	2.42	OTASPRrequest	107
37	2.43	ParameterRequest	111
38	2.44	QualificationDirective	113
39	2.45	QualificationRequest	115
40	2.46	RandomVariableRequest	118
41	2.47	RedirectionDirective	119
42	2.48	RedirectionRequest	121
43	2.49	RegistrationCancellation	123
44			
45			
46			
47			
48			
49			
50			
51			
52			
53			
54			
55			
56			
57			
58			
59			
60			

2.50	RegistrationNotification	125	1
2.51	Release	129	2
2.52	RemoteUserInteractionDirective	130	3
2.53	ResetCircuit	131	4
2.54	ResetTimer	132	5
2.55	RoutingRequest	133	6
2.56	Search	137	7
2.57	SeizeResource	139	8
2.58	ServiceRequest	140	9
2.59	SMSDeliveryBackward	144	10
2.60	SMSDeliveryForward	146	11
2.61	SMSDeliveryPointToPoint	148	12
2.62	SMSDeliveryPointToPointAck	151	13
2.63	SMSNotification	152	14
2.64	SMSRequest	154	15
2.65	SRFDirective	156	16
2.66	TBusy	158	17
2.67	TMSIDirective	162	18
2.68	TNoAnswer	164	19
2.69	TransferToNumberRequest	168	20
2.70	TrunkTest	172	21
2.71	TrunkTestDisconnect	173	22
2.72	Unblocking	174	23
2.73	UnreliableRoamerDataDirective	175	24
2.74	UnsolicitedResponse	176	25
			26
			27
			28
			29
			30
			31
			32
			33
			34
			35
			36
			37
			38
			39
1	GENERAL	1	40
1.1	PARAMETER FORMAT	1	41
1.1.1	Transmission order	2	42
1.2	PARAMETER IDENTIFIERS	2	43
			44
			45
2	PARAMETER DEFINITIONS	23	46
2.1	AccessDeniedReason	23	47
2.2	ActionCode	25	48
2.3	AKeyProtocolVersion	27	49
2.4	AlertCode	28	50
2.5	AlertResult	30	51
2.6	AllOrNone	31	52
2.7	AnalogRedirectInfo	32	53
2.8	AnalogRedirectRecord	33	54
2.9	AnnouncementCode	34	55
2.10	AnnouncementList	44	56
			57
			58
			59
			60

1	2.11	AuthenticationAlgorithmVersion	45
2	2.12	AuthenticationCapability	46
3	2.13	AuthenticationData	47
4	2.14	AuthenticationResponse	48
5	2.15	AuthenticationResponseBaseStation	49
6	2.16	AuthenticationResponseReauthentication	50
7	2.17	AuthenticationResponseUniqueChallenge	51
8	2.18	AuthorizationDenied	52
9	2.19	AuthorizationPeriod	53
10	2.20	AvailabilityType	54
11	2.21	BaseStationManufacturerCode	55
12	2.22	BaseStationPartialKey	56
13	2.23	BillingID	57
14	2.24	BorderCellAccess	58
15	2.25	BSMCStatus	59
16	2.26	CallHistoryCount	60
17	2.27	CallHistoryCountExpected	61
18	2.28	CallingFeaturesIndicator	62
19	2.29	CallingPartyName	64
20	2.30	CallingPartyNumberDigits1	65
21	2.31	CallingPartyNumberDigits2	66
22	2.32	CallingPartyNumberString1	67
23	2.33	CallingPartyNumberString2	68
24	2.34	CallingPartySubaddress	69
25	2.35	CancellationDenied	70
26	2.36	CancellationType	71
27	2.37	CarrierDigits	72
28	2.38	CaveKey	73
29	2.39	CDMA2000HandoffInvokeIOSData	74
30	2.40	CDMA2000HandoffResponseIOSData	75
31	2.41	CDMA2000MobileSupportedCapabilities	76
32	2.42	CDMABandClass	77
33	2.43	CDMABandClassInformation	78
34	2.44	CDMABandClassList	79
35	2.45	CDMACallMode	80
36	2.46	CDMAChannelData	82
37	2.47	CDMAChannelNumber	84
38	2.48	CDMAChannelNumberList	85
39	2.49	CDMACodeChannel	86
40	2.50	CDMACodeChannelInformation	87
41	2.51	CDMACodeChannelList	88
42	2.52	CDMAConnectionReference	89
43	2.53	CDMAConnectionReferenceInformation	90

2.54	CDMAConnectionReferenceList	91	1
2.55	CDMAMobileProtocolRevision	92	2
2.56	CDMAMSMeasuredChannelIdentity	93	3
2.57	CDMANetworkIdentification	94	4
2.58	CDMAPilotPN	95	5
2.59	CDMAPilotStrength	96	6
2.60	CDMAPowerCombinedIndicator	97	7
2.61	CDMAPrivateLongCodeMask	98	8
2.62	CDMAREdirectRecord	99	9
2.63	CDMASearchParameters	100	10
2.64	CDMASearchWindow	101	11
2.65	CDMAServiceConfigurationRecord	102	12
2.66	CDMAServiceOption	103	13
2.67	CDMAServiceOptionList	104	14
2.68	CDMAServingOneWayDelay	105	15
2.69	CDMASignalQuality	106	16
2.70	CDMASlotCycleIndex	107	17
2.71	CDMAState	108	18
2.72	CDMAStationClassMark	109	19
2.73	CDMAStationClassMark2	111	20
2.74	CDMATargetMAHOInformation	112	21
2.75	CDMATargetMAHOList	113	22
2.76	CDMATargetMeasurementInformation	114	23
2.77	CDMATargetMeasurementList	115	24
2.78	CDMATargetOneWayDelay	116	25
2.79	Change	117	26
2.80	ChangeServiceAttributes	118	27
2.81	ChannelData	119	28
2.82	CommandCode	120	29
2.83	ConditionallyDeniedReason	121	30
2.84	ConferenceCallingIndicator	122	31
2.85	ConfidentialityModes	123	32
2.86	ControlChannelData	125	33
2.87	ControlChannelMode	126	34
2.88	CountUpdateReport	127	35
2.89	DataAccessElement	128	36
2.90	DataAccessElementList	129	37
2.91	DatabaseKey	130	38
2.92	DataID	131	39
2.93	DataKey	132	40
2.94	DataPrivacyParameters	133	41
2.95	DataResult	134	42
2.96	DataUpdateResult	135	43
			44
			45
			46
			47
			48
			49
			50
			51
			52
			53
			54
			55
			56
			57
			58
			59
			60

1	2.97 DataUpdateResultList	136
2	2.98 DataValue	137
3	2.99 DeniedAuthorizationPeriod	138
4	2.100 DenyAccess	140
5	2.101 DeregistrationType	141
6	2.102 DestinationAddress	142
7	2.103 DestinationDigits	143
8	2.104 DigitCollectionControl	144
9	2.105 Digits	147
10	2.106 DisplayText	149
11	2.107 DisplayText2	150
12	2.108 DMH_AccountCodeDigits	151
13	2.109 DMH_AlternateBillingDigits	152
14	2.110 DMH_BillingDigits	153
15	2.111 DMH_RedirectionIndicator	154
16	2.112 ElectronicSerialNumber	155
17	2.113 EmergencyServicesRoutingDigits	156
18	2.114 EnhancedPrivacyEncryptionReport	157
19	2.115 ExecuteScript	158
20	2.116 ExtendedMSCID	159
21	2.117 ExtendedSystemMyTypeCode	160
22	2.118 FailureCause	161
23	2.119 FailureType	162
24	2.120 FaultyParameter	163
25	2.121 FeatureResult	164
26	2.122 GeographicAuthorization	165
27	2.123 GlobalTitle	166
28	2.124 GroupInformation	167
29	2.125 HandoffReason	168
30	2.126 HandoffState	169
31	2.127 IMSI	170
32	2.128 InterMessageTime	171
33	2.129 InterMSCCircuitID	172
34	2.130 InterSwitchCount	173
35	2.131 IntersystemTermination	174
36	2.132 ISLPInformation	176
37	2.133 LegInformation	177
38	2.134 LocalTermination	178
39	2.135 LocationAreaID	180
40	2.136 MessageWaitingNotificationCount	181
41	2.137 MessageWaitingNotificationType	182
42	2.138 MINExtension	184
43	2.139 MobileDirectoryNumber	185
44		
45		
46		
47		
48		
49		
50		
51		
52		
53		
54		
55		
56		
57		
58		
59		
60		

2.140	MobileIdentificationNumber	186	1
2.141	MobileStationIMSI	187	2
2.142	MobileStationMIN	188	3
2.143	MobileStationMSID	189	4
2.144	MobileStationPartialKey	190	5
2.145	ModificationRequest	191	6
2.146	ModificationRequestList	192	7
2.147	ModificationResult	193	8
2.148	ModificationResultList	194	9
2.149	ModulusValue	195	10
2.150	MSC_Address	196	11
2.150.1	MSC_Address parameter for BCD Digits	196	12
2.150.2	MSC_Address parameter for an IP address	197	13
2.150.3	MSC_Address parameter for a generic SS7 Point Code address	198	14
2.151	MSCID	199	15
2.152	MSCIdentificationNumber	200	16
2.153	MSID	201	17
2.154	MSIDUsage	202	18
2.155	MSLocation	203	19
2.156	NAMPSCallMode	204	20
2.157	NAMPSChannelData	206	21
2.158	NetworkTMSI	208	22
2.159	NetworkTMSIExpirationTime	209	23
2.160	NewlyAssignedIMSI	210	24
2.161	NewlyAssignedMIN	211	25
2.162	NewlyAssignedMSID	212	26
2.163	NewMINExtension	213	27
2.164	NewNetworkTMSI	215	28
2.165	NoAnswerTime	216	29
2.166	NonPublicData	217	30
2.167	OneTimeFeatureIndicator	219	31
2.168	OriginationIndicator	222	32
2.169	OriginationTriggers	224	33
2.170	OTASP_ResultCode	229	34
2.171	PACAIndicator	230	35
2.172	PageCount	232	36
2.173	PageIndicator	233	37
2.174	PageResponseTime	234	38
2.175	PagingFrameClass	235	39
2.176	PC_SSN	236	40
2.176.1	PC_SSN (ANSI)	236	41
2.176.2	PC_SSN (Generic)	237	42
2.177	PilotBillingID	238	43
2.178	PilotNumber	239	44
			45
			46
			47
			48
			49
			50
			51
			52
			53
			54
			55
			56
			57
			58
			59
			60

1	2.179 PreferredLanguageIndicator	240
2	2.180 PrimitiveValue	243
3	2.181 PrivateSpecializedResource	244
4	2.182 Profile	245
5	2.183 PSID_RSIDInformation	248
6	2.184 PSID_RSIDList	250
7	2.185 PSTNTermination	251
8	2.186 QoSPriority	252
9	2.187 QualificationInformationCode	253
10	2.188 RANDC	254
11	2.189 RandomVariable	255
12	2.190 RandomVariableBaseStation	256
13	2.191 RandomVariableReauthentication	257
14	2.192 RandomVariableSSD	258
15	2.193 RandomVariableUniqueChallenge	259
16	2.194 RANDValidTime	260
17	2.195 ReasonList	261
18	2.196 ReauthenticationReport	262
19	2.197 ReceivedSignalQuality	263
20	2.198 RedirectingNumberDigits	264
21	2.199 RedirectingNumberString	265
22	2.200 RedirectingPartyName	266
23	2.201 RedirectingSubaddress	267
24	2.202 RedirectionReason	268
25	2.203 ReleaseReason	269
26	2.204 ReportType	270
27	2.205 RequiredParametersMask	272
28	2.206 RestrictionDigits	274
29	2.207 RingStartDelay	275
30	2.208 RoamingIndication	276
31	2.209 RoutingDigits	277
32	2.210 ScriptArgument	278
33	2.211 ScriptName	279
34	2.212 ScriptResult	280
35	2.213 SecondInterMSCCircuitID	281
36	2.214 SeizureType	282
37	2.215 SenderIdentificationNumber	283
38	2.216 ServiceDataAccessElement	284
39	2.217 ServiceDataAccessElementList	285
40	2.218 ServiceDataResult	286
41	2.219 ServiceDataResultList	287
42	2.220 ServiceID	288
43	2.221 ServiceIndicator	289
44		
45		
46		
47		
48		
49		
50		
51		
52		
53		
54		
55		
56		
57		
58		
59		
60		

2.222	ServiceRedirectionCause	290	1
2.223	ServiceRedirectionInfo	291	2
2.224	ServicesResult	292	3
2.225	ServingCellID	293	4
2.226	SetupResult	294	5
2.227	SharedSecretData	295	6
2.228	SignalingMessageEncryptionKey	296	7
2.229	SignalingMessageEncryptionReport	297	8
2.230	SignalQuality	298	9
2.231	SMS_AccessDeniedReason	301	10
2.232	SMS_Address	303	11
2.232.1	SMS_Address parameter for BCD digits	303	12
2.232.2	SMS_Address Encoding for an IP address	304	13
2.232.3	SMS_Address Encoding for an ANSI SS7 Point Code Address	305	14
2.232.4	SMS_Address Encoding for a Generic SS7 Point Code Address	306	15
2.233	SMS_BearerData	307	16
2.234	SMS_CauseCode	308	17
2.235	SMS_ChargeIndicator	312	18
2.236	SMS_DestinationAddress	313	19
2.236.1	SMS_DestinationAddress parameter for BCD Digits	313	20
2.236.2	SMS_DestinationAddress parameter for an IP Address	314	21
2.237	SMS_MessageCount	315	22
2.238	SMS_MessageWaitingIndicator	316	23
2.239	SMS_NotificationIndicator	317	24
2.240	SMS_OriginalDestinationAddress	318	25
2.240.1	SMS_OriginalDestinationAddress parameter for BCD Digits	318	26
2.240.2	SMS_OriginalDestinationAddress parameter for IA5 Digits	319	27
2.240.3	SMS_OriginalDestinationAddress parameter for an IP Address	320	28
2.241	SMS_OriginalDestinationSubaddress	321	29
2.242	SMS_OriginalOriginatingAddress	322	30
2.242.1	SMS_OriginalOriginatingAddress for BCD Digits	322	31
2.242.2	SMS_OriginalOriginatingAddress parameter for IA5 Digits	323	32
2.242.3	SMS_OriginalOriginatingAddress parameter for an IP Address	324	33
2.243	SMS_OriginalOriginatingSubaddress	325	34
2.244	SMS_OriginatingAddress	326	35
2.244.1	SMS_OriginatingAddress parameter for BCD Digits	326	36
2.244.2	SMS_OriginalOriginatingAddress parameter for an IP Address	327	37
2.245	SMS_OriginationRestrictions	328	38
2.246	SMS_TeleserviceIdentifier	329	39
2.247	SMS_TerminationRestrictions	331	40
2.248	SMS_TransactionID	332	41
2.249	SpecialHandling	333	42
2.250	SpecializedResource	334	43
2.251	SPINIPIN	335	44
2.252	SPINITriggers	336	45

1	2.253 SSDNotShared	341
2	2.254 SSDUpdateReport	342
3	2.255 StationClassMark	343
4	2.256 SuspiciousAccess	344
5	2.257 SystemAccessData	345
6	2.258 SystemAccessType	346
7	2.259 SystemCapabilities	347
8	2.260 SystemMyTypeCode	349
9	2.261 SystemOperatorCode	351
10	2.262 SOCStatus	352
11	2.263 TargetCellID	353
12	2.264 TargetCellIDList	354
13	2.265 TargetMeasurementInformation	355
14	2.266 TargetMeasurementList	356
15	2.267 TDMABandwidth	357
16	2.268 TDMABurstIndicator	358
17	2.269 TDMACallMode	359
18	2.270 TDMAChannelData	361
19	2.271 TDMADataFeaturesIndicator	363
20	2.272 TDMADataMode	364
21	2.273 TDMAServiceCode	366
22	2.274 TDMA TerminalCapability	367
23	2.275 TDMAVoiceCoder	371
24	2.276 TDMAVoiceMode	372
25	2.277 TemporaryReferenceNumber	373
26	2.278 TerminalType	374
27	2.279 TerminationAccessType	376
28	2.280 TerminationList	377
29	2.281 TerminationRestrictionCode	378
30	2.282 TerminationTreatment	379
31	2.283 TerminationTriggers	380
32	2.284 TimeDateOffset	383
33	2.285 TransactionCapability	385
34	2.286 TriggerAddressList	388
35	2.287 TriggerCapability	389
36	2.288 TriggerList	392
37	2.289 TriggerType	393
38	2.290 TrunkStatus	395
39	2.291 UniqueChallengeReport	396
40	2.292 UpdateCount	397
41	2.293 UserGroup	398
42	2.294 UserZoneData	399
43	2.295 VoiceMailboxNumber	401
44		
45		
46		
47		
48		
49		
50		
51		
52		
53		
54		
55		
56		
57		
58		
59		
60		

2.296	VoiceMailboxPIN	402	1
2.297	VoicePrivacyMask	403	2
2.298	VoicePrivacyReport	404	3
2.299	WINCapability	405	4
2.300	WINOperationsCapability	406	5
2.301	WIN_TriggerList	407	6

Part 551

1	PARAMETER TYPE DEFINITIONS	1	13
1.1	CHOICE	1	14
1.2	DigitsType	1	15
1.2.1	DigitsType variant for BCD digits	1	16
1.2.2	DigitsType variant for IA5 digits	3	17
1.2.3	DigitsType variant for IP address	4	18
1.2.4	DigitsType variant for an ANSI SS7 point code address	5	19
1.2.5	DigitsType variant for a generic SS7 point code address	6	20
1.3	ENUMERATED	9	21
1.4	IMPLICIT	10	22
1.5	IMSIType	12	23
1.6	INTEGER	14	24
1.7	MINType	15	25
1.8	NULL	16	26
1.9	OCTET STRING.....	16	27
1.10	SEQUENCE	16	28
1.11	SEQUENCE OF.....	16	29
1.12	SEQUENCE OF CHOICE	16	30
1.13	SET.....	16	31
1.14	SET OF CHOICE.....	17	32
1.15	SUBADDRESS	17	33
1.16	UNSIGNED ENUMERATED.....	18	34
1.17	UNSIGNED INTEGER	18	35

Part 590

1	MAP COMPATIBILITY GUIDELINES AND RULES.....	1	46
1.1	ACHIEVING FORWARD COMPATIBILITY AND BACKWARD COMPATIBILITY ...	1	47
1.1.1	Forward Compatibility	1	48
1.1.2	Backward Compatibility	1	49
1.2	GUIDELINES FOR FORWARD COMPATIBILITY	1	50
1.3	GUIDELINES FOR BACKWARD COMPATIBILITY	4	51
1.3.1	Existing Messages.....	4	52
1.3.2	Parameters in Existing Messages	4	53
1.3.3	New Messages.....	5	54

1 1.3.4 New Parameters5
 2 1.3.5 New Parameter Fields5
 3 1.3.6 New Parameter Values5
 4
 5
 6

7 Part 700

9 1 INTRODUCTION 1
 10 1.1 OBJECTIVE.....2
 11 1.2 SCOPE2
 12
 13 2 WIN DISTRIBUTED FUNCTIONAL PLANE3
 14 2.1 Scope of WIN Distributed Functional Plane.....3
 15 2.1.1 End User Access3
 16 2.1.2 Service Invocation and Control.....3
 17 2.1.3 End User Interaction4
 18 2.1.4 Service Management5
 19
 20
 21
 22

23 Part 730

25 1 WIN DISTRIBUTED FUNCTIONAL MODEL 1
 26 1.1 WIN Functional Model3
 27 1.2 WIN Functional Entities.....3
 28 1.2.1 Authentication Control Function (ACF)3
 29 1.2.2 Call Control Function (CCF)3
 30 1.2.3 Location Registration Functions (LRFh, LRFv)4
 31 1.2.4 Mobile Station Access Control Function (MACF)4
 32 1.2.5 Radio Access Control Function (RACF)5
 33 1.2.6 Radio Control Function (RCF).....6
 34 1.2.7 Radio Terminal Function (RTF)6
 35 1.2.8 Service Control Function (SCF).....6
 36 1.2.9 Service Creation Entity Function (SCEF).....6
 37 1.2.10 Service Data Function (SDF)7
 38 1.2.11 Service Management Access Function (SMAF).....7
 39 1.2.12 Service Management Function (SMF)7
 40 1.2.13 Service Switching Function (SSF).....7
 41 1.2.14 Specialized Resource Function (SRF)7
 42
 43
 44
 45
 46
 47

48 Part 750

49 1 SSF/CCF CALL AND SERVICE LOGIC MODEL 1
 50 1.1 General 1
 51 1.1.1 Feature and Service Interaction Management2
 52 1.1.2 Feature Interactions Manager (FIM) - SSF/CCF3
 53 1.1.3 Service Interactions Manager (SIM) - SCF6
 54 1.2 SSF/CCF Model8
 55 1.2.1 Basic Call Manager (BCM)10
 56 1.2.1.1 BCSM.....10
 57
 58
 59
 60

1.2.2	WIN BCSM Description	12	1
1.2.2.1	Originating BCSM	12	2
1.2.2.2	Terminating BCSM.....	21	3
1.2.2.3	BCSM Transitions.....	28	4
1.2.3	BCSM Detection Points	32	5
1.2.3.1	Detection Points Types	34	6
1.2.3.2	Trigger Detection Point Criteria	34	7
1.2.3.3	Triggers	36	8
1.2.3.4	Trigger Types and Trigger Precedence.....	37	9
1.2.3.5	Trigger Profile.....	49	10
1.2.3.6	DP Processing	49	11
			12
			13
			14
			15
			16
			17
			18
			19
			20
			21
			22
			23
			24
			25
			26
			27
			28
			29
			30
			31
			32
			33
			34
			35
			36
			37
			38
			39
			40
			41
			42
			43
			44
			45
			46
			47
			48
			49
			50
			51
			52
			53
			54
			55
			56
			57
			58
			59
			60

Part 790

Annex B: Mapping of WIN Functional Entities to Network Entities

Annex C: Notes on Trigger Concepts and Usage

1
2
3
4
5
6
7
8
9
10
11
12
13
14
15
16
17
18
19
20
21
22
23
24
25
26
27
28
29
30
31
32
33
34
35
36
37
38
39
40
41
42
43
44
45
46
47
48
49
50
51
52
53
54
55
56
57
58
59
60

C.13 Issues in Selecting Overlapping Trigger Arming Parameters.....21
C.14 Distributed Triggers22
C.15 Distributed Triggers Example22
C.16 Dynamic Trigger Arming Mechanism23
C.17 Dynamic Trigger Arming Can Readily Be Misused.....23
C.18 Evolution to WIN.....24
C.19 General Responsibility of Service Providers24

1
2
3
4
5
6
7
8
9
10
11
12
13
14
15
16
17
18
19
20
21
22
23
24
25
26
27
28
29
30
31
32
33
34
35
36
37
38
39
40
41
42
43
44
45
46
47
48
49
50
51
52
53
54
55
56
57
58
59
60

List of Tables

	Part 000	
Table 1	Part Structure	8
Table 2	Symbols and Abbreviations	28
	Part 511	
Table 1	TIA-41 Operations having MTP Message Priority Value 1	1
Table 2	ANSI SS7 - MIN to HLR Global Title	3
Table 3	ANSI SS7 - MIN to MC Global Title	4
Table 4	ANSI SS7 - E.212 Global Title	5
Table 5	ANSI SS7 - MDN to HLR (E.164) Global Title	6
Table 6	ANSI SS7 - MDN to MC (E.164) Global Title	7
Table 7	ANSI SS7 - IMSI to MC Global Title	8
Table 8	ANSI SS7 - DN to NPDB Global Title	9
Table 9	ANSI SS7 - SCP Global Title Addressing	10
	Part 512	
Table 1	ITU-T SS7 - E.212 Global Title	3
Table 2	ITU-T SS7 - E.164 Global Title	4
	Part 520	
Table 1	Structure of TCAP Package with INVOKE Component	4
Table 2	Structure of TCAP Package with RETURN RESULT Component	6
Table 3	Structure of TCAP Package with RETURN ERROR Component	7
Table 4	Error Codes	10
Table 5	Structure of TCAP Package with REJECT Component	11
	Part 540	
Table 1	TIA-41 MAP Operation Specifiers	1
Table 2	Mapping of TIA-41 Operations onto TCAP Package Types	4
Table 3	Summary of MAP Operations	6
Table 1	TIA-41 MAP Parameter Identifiers	2
	Part 590	
Table 1	Forward Compatibility Guidelines for Handling Incoming Messages and Parameters	2
	Part 750	
Table 1	Originating BCSM Transitions	29
Table 2	Terminating BCSM Transitions	31
Table 3	BCSM DP Types	34
Table 4	WIN Trigger Precedence for Originating BCSM	38
Table 5	WIN Trigger Precedence for Terminating BCSM	39
Table 6	Information Contained in Trigger Profile	49
	Part 790	
Table 1	Mapping of WIN Functional Entities to Network Entities	18

1
2
3
4
5
6
7
8
9
10
11
12
13
14
15
16
17
18
19
20
21
22
23
24
25
26
27
28
29
30
31
32
33
34
35
36
37
38
39
40
41
42
43
44
45
46
47
48
49
50
51
52
53
54
55
56
57
58
59
60

List of Figures

Part 000

Figure 1	Diagrammatic Conventions:	51
Figure 2	TCAP Package Type Diagram Conventions.....	55

Part 500

Figure 1	MAP Protocol Architecture	1
Figure 2	OSI Reference Model Relationship	2
Figure 3	Application Services	2
Figure 4	X.25-based Data Transfer Services.....	3
Figure 5	SS7-based Data Transfer Services	3

Part 520

Figure 1	Application Services Architecture	1
Figure 2	TIA-41 Application Layer Structure.....	2

Part 540

Figure 1	Definition of Signal Quality for Handoff.....	299
----------	---	-----

Part 730

Figure 1	WIN Distributed Functional Model	2
----------	--	---

Part 750

Figure 1	Feature Interactions Manager at the SSF/CCF	3
Figure 2	Effect of “Continue” Response to SSF /CCF.....	4
Figure 3	Effect of Returning to a Different PIC at the SSF/CCF.....	5
Figure 4	Service Interactions Manager at the SCF.....	6
Figure 5	SSF/CCF Model.....	8
Figure 6	BCSM Components	11
Figure 7	Originating BCSM.....	13
Figure 8	Terminating BCSM.....	22
Figure 9	DP Processing for each DP type	51

Part 790

Figure 1	TIA-41 Registration and “Call From” Signaling	2
Figure 2	TIA-41 “Call To” Signaling.....	4
Figure 3	Call Segments for Intrasystem MS to MS Call.....	5
Figure 4	BCSMs for Normal Intrasystem Call Delivery (1 of 2).....	6
Figure 4	BCSMs for Normal Intrasystem Call Delivery (2 of 2).....	7
Figure 5	Call Segments for Intersystem MS to MS Call.....	8
Figure 6	Originating System BCSMs for Normal Intersystem Call Delivery (1 of 2).....	9
Figure 6	Originating System BCSMs for Normal Intersystem Call Delivery (2 of 2).....	10
Figure 7	Serving System BCSMs for Normal Intersystem Call Delivery (1 of 2).....	13
Figure 7	Serving System BCSMs for Normal Intersystem Call Delivery (2 of 2).....	14
Figure 8	Mapping WIN Functional Entities to Network Entities.....	17
Figure 9	Distributed Trigger Profiles	23

1
2
3
4
5
6
7
8
9
10
11
12
13
14
15
16
17
18
19
20
21
22
23
24
25
26
27
28
29
30
31
32
33
34
35
36
37
38
39
40
41
42
43
44
45
46
47
48
49
50
51
52
53
54
55
56
57
58
59
60

1 **PART 000 - INTRODUCTION TO TIA - 41**
2
3

4
5 **FOREWORD**
6

7
8 This Foreword is not part of this Standard.
9

10 This is one of a series of recommendations entitled:
11

12
13 “CELLULAR RADIOTELECOMMUNICATIONS INTERSYSTEM OPERATIONS”
14

15
16 which describe procedures necessary to provide to cellular radio telephone subscribers certain
17 services requiring interaction between different cellular systems.
18

19 It is the intention of TIA TR-45.2 Subcommittee, Cellular System Operations, that this series of
20 recommendations address the ongoing and developing concerns of the Cellular
21 Radiotelecommunications Industry—subscribers, service providers, and manufacturers alike—with
22 regard to useful and effective services requiring standardized intersystem procedures.
23

24
25 This part provides an introduction to *TIA-41*.
26
27
28
29
30
31
32
33
34
35
36
37
38
39
40
41
42
43
44
45
46
47
48
49
50
51
52
53
54
55
56
57
58
59
60

1 COMPARISON WITH IS-41-C/ANS-41-D

This edition of the Standard replaces *TIA/EIA-41-D* and differs from this previous edition in its support of the following functionality:

Content from...	Description
TSB-76	PCS Multi-band
IS-725-A	OTASP and OTAPA
IS-730	DCCH
IS-735	CDMA
IS-737	Circuit Mode Services - Data
IS-751	IMSI
IS-756-A	WNP Phase 1 and Phase 2
IS-764	CNAP/CNAR
IS-771	Wireless Intelligent Networking (WIN Phase I)
IS-778	Authentication Enhancements
IS-807	Internationalization
IS-812	Message Segmentation
J-STD-034	Emergency Services
Miscellaneous Enhancements 10, 10.9, 10.9b and 10.9c	Technical Clarifications and Compatibility

The following new operations have been added in this revision:

Operation Name
AnalyzedInformation
ChangeFacilities
ChangeService
ConnectionFailureReport
ConnectResource
DisconnectResource
FacilitySelectedAndAvailable
InstructionRequest
MessageDirective
Modify
NumberPortabilityRequest
OTASPRquest
ParameterRequest
Release

Operation Name
ResetTimer
Search
SeizeResource
ServiceRequest
SMSDeliveryPointToPointAck
SRFDirective
TBusy
TMSIDirective
TNoAnswer

The following new parameters have been added in this revision:

Parameter Name
AKeyProtocolVersion
AllorNone
AnalogRedirectInfo
AnalogRedirectRecord
AuthenticationResponseReauthentication
BaseStationManufacturerCode
BaseStationPartialKey
BSMCStatus
CallingPartyName
CaveKey
CDMABandClassInformation
CDMA2000HandoffInvokeIOSData
CDMA2000HandoffResponseIOSData
CDMA2000MobileSupportedCapabilities
CDMAMSMMeasuredChannelIdentity
CDMABandClass
CDMABandClassList
CDMAChannelNumber
CDMAChannelNumberList
CDMAConnectionReference
CDMAConnectionReferenceInformation
CDMAConnectionReferenceList
CDMANetworkIdentification
CDMAPilotPN

Parameter Name	
CDMAPowerCombinedIndicator	1
CDMARedirectRecord	2
CDMASearchParameters	3
CDMAServiceConfigurationRecord	4
CDMAServiceOption	5
CDMAServiceOptionList	6
CDMAState	7
CDMAStationClassMark2	8
Change	9
ChangeServiceAttributes	10
CommandCode	11
ControlChannelCapability	12
ControlChannelMode	13
DataAccessElement	14
DataAccessElementList	15
DatabaseKey	16
DataID	17
DataKey	18
DataPrivacyParameters	19
DataResult	20
DataUpdateResult	21
DataUpdateResultList	22
DataValue	23
DestinationAddress	24
DigitsType	25
DisplayText	26
DisplayText2	27
EmergencyServicesRoutingDigits	28
EnhancedPrivacyEncryptionReport	29
ExecuteScript	30
FailureCause	31
FailureType	32
GlobalTitle	33
IMSI	34
InterMessageTime	35
ISLPIInformation	36
MobileStationIMSI	37
	38
	39
	40
	41
	42
	43
	44
	45
	46
	47
	48
	49
	50
	51
	52
	53
	54
	55
	56
	57
	58
	59
	60

1
2
3
4
5
6
7
8
9
10
11
12
13
14
15
16
17
18
19
20
21
22
23
24
25
26
27
28
29
30
31
32
33
34
35
36
37
38
39
40
41
42
43
44
45
46
47
48
49
50
51
52
53
54
55
56
57
58
59
60

Parameter Name
MobileStationMIN
MobileStationMSID
MobileStationPartialKey
ModificationRequest
ModificationRequestList
ModificationResult
ModificationResultList
ModulusValue
MSC_Address
MSID
MSIDUsage
NetworkTMSI
NetworkTMSIExpirationTime
NewlyAssignedIMSI
NewlyAssignedMIN
NewlyAssignedMSID
NewMINExtension
NewNetworkTMSI
NonPublicData
OTASP_ResultCode
PageCount
PageResponseTime
PagingFrameClass
PDITimer
PrimitiveValue
PrivateSpecializedResource
PSID_RSIDInformation
PSID_RSIDList
QoSPriority
RandomVariableReauthentication
ReasonList
ReauthenticationReport
RedirectingPartyName
RequiredParametersMask
RoamingIndication
ScriptArgument
ScriptName

Parameter Name
ScriptResult
SecondInterMSCCircuitID
ServiceDataAccessElement
ServiceDataAccessElementList
ServiceDataResult
ServiceDataResultList
ServiceID
ServiceIndicator
ServiceRedirectionCause
ServiceRedirectionInfo
ServicesResult
SignalingMessageEncryptionReport
SMS_TransactionID
SOCStatus
SpecialHandling
SpecializedResource
SuspiciousAccess
SystemOperatorCode
TargetCellIDList
TDMABandwidth
TDMADataFeaturesIndicator
TDMADataMode
TDMAServiceCode
TDMA TerminalCapability
TDMAVoiceCoder
TDMAVoiceMode
TemporaryReferenceNumber
TimeDateOffset
TriggerAddressList
TriggerCapability
TriggerList
TriggerType
UserGroup
UserZoneData
VoicePrivacyReport
WINCapability

1
2
3
4
5
6
7
8
9
10
11
12
13
14
15
16
17
18
19
20
21
22
23
24
25
26
27
28
29
30
31
32
33
34
35
36
37
38
39
40
41
42
43
44
45
46
47
48
49
50
51
52
53
54
55
56
57
58
59
60

1
2
3
4
5
6
7
8
9
10
11
12
13
14
15
16
17
18
19
20
21
22
23
24
25
26
27
28
29
30
31
32
33
34
35
36
37
38
39
40
41
42
43
44
45
46
47
48
49
50
51
52
53
54
55
56
57
58
59
60

Parameter Name
WINOperationsCapability
WIN_TriggerList

2 PART STRUCTURE

Table 1 Part Structure

Part	Contents	Previously (TIA/EIA-41-D)	Publication Date
TIA-41-000-E	Introduction to TIA-41	Chapter 1	March 2004
TIA-41-200-E	Introduction to Intersystem Handoffs Stage 2		Under development
TIA-41-201-E	Section 5 (Section 4 deleted)		
TIA-41-290-E	Annex A: Additional DMH Support for Intersystem Handoff in TIA-41		
TIA-41-300-E	Introduction to Automatic Roaming Stage 2		Under development
TIA-41-310-E	Authentication and Registration Scenarios (Section 4 deleted)		
TIA-41-311-E	Basic Feature Processing		
TIA-41-312-E	Automatic Roaming Maintenance		
TIA-41-321-E to 345	Voice Feature Scenarios		
TIA-41-370-E	SMS Scenarios		
TIA-41-390-E	Annex A: Assumptions for MS Authentication, Signaling Message Encryption and Voice Privacy		
TIA-41-400-E	Introduction to OA&M		
TIA-41-410-E	Intersystem Handoff OA&M (Section 4 deleted)		
TIA-41-420-E	Inter-MSC Trunk Testing		
TIA-41-500-E	Introduction to Signaling Protocols	Chapter 5	March 2004
TIA-41-510-E	X.25		
TIA-41-511-E	ANS SS7		
TIA-41-512-E	ITU SS7		
TIA-41-520-E	TCAP		
TIA-41-540-E	Operations		
TIA-41-550-E	Parameters		
TIA-41-551-E	Parameter Type Definitions		
TIA-41-590-E	MAP Compatibility Guidelines and Rules		

Part	Contents	Previously (TIA/EIA-41-D)	Publication Date
TIA-41-600-E	Introduction to Signaling Procedures		Under development
TIA-41-630-E	Basic Call Processing		
TIA-41-640-E	Intersystem Operations		
TIA-41-641-E	SMS		
TIA-41-650-E	Common Voice Feature Procedures		
TIA-41-651-E to 674	Voice Features		
TIA-41-690-E	Timer Values		
TIA-41-691-E	Annexes for TIA-41-6XX series (Procedures for RANDC Verification, Procedures for SSD Management at AC, Authentication Response Verification, SMS Air Interface Delivery Point-to-Point and Signal Strength Arbitration)		
TIA-41-700-E	Introduction WIN Functional Plane	IS-771	March 2004
TIA-41-730-E	WIN Distributed Plane and Model		
TIA-41-750-E	SSF/CCF Call and Service Logic Model		
TIA-41-790-E	Annexes for TIA-41-7XX series (Location Registration Function, Call Delivery using the BCSM, Mapping of WIN Functional Entities to Network Entities, Notes on Trigger Concepts and Usage).		

2.1 OBJECTIVE

The purpose of this standard is to identify those cellular services which require intersystem cooperation, to present the general background against which those services are to be provided, and to summarize the principal considerations which have governed and directed the particular approaches taken in the procedural recommendations.

2.2 SCOPE

This part defines the range of application of the current issue of the series. It focuses on overall objectives and basic assumptions. Procedural details are presented in the other recommendations.

2.3 REFERENCES

2.3.1 Normative References

The documents that are referenced herein are for the sole purpose of identifying related normative reference sources and were used in the formulation of this standard. There are no direct or indirect claims regarding the property rights, legal or regulatory status of those documents listed.

CCITT 1992:		1
		2
[T.50]	T.50 International Reference Alphabet (IRA) formerly international Alphabet No. 5 (or IA5)	3
		4
		5
CBC:		6
		7
[TIA-1020]	Band Class Specification for cdma2000 Spread Spectrum Systems, February 2004	8
		9
		10
ITU:		11
		12
[E.164]	Rec. E.164: The international public telecommunication numbering plan, 1997	13
		14
		15
[E.212]	Rec. E.212: The international identification plan for mobile terminals and mobile users, 1998	16
		17
		18
[Q.700]	Q.700 Introduction to CCITT Signalling System No. 7, 1993	19
		20
[Q.701]	Q.701 Functional description of the message transfer part (MTP) of signalling system No. 7, 1993	21
		22
		23
[Q.702]	Q702 Signalling data link, 1989	24
		25
[Q.703]	Q.703 Signalling link, 1996	26
		27
[Q.704]	Q.704 Signalling network functions and messages, 1996	28
		29
[Q.705]	Q.705 Signalling network structure, 1993	30
		31
[Q.706]	Q.706 Message transfer part signalling performance, 1993	32
		33
[Q.707]	Q.707 Testing and maintenance, 1989	34
		35
[Q.708]	Q.708 Assignment procedures for international signalling point codes, 1999	36
		37
[Q.709]	Q.709 Hypothetical signalling reference connection, 1993	38
		39
[Q.710]	Q.710 Simplified MTP version for small systems, 1989	40
		41
[Q.711]	Q.711 Functional description of the signalling connection control part, 2001	42
		43
[Q.712]	Q.712 Definition and function of SCCP messages, 1996	44
		45
[Q.713]	Q.713 SCCP formats and codes, 2001	46
		47
[Q.714]	Q.714 Signalling connection control part procedures, 2001	48
		49
[Q.716]	Q.716 Signalling connection control part (SCCP) performances, 1993	50
		51
[Q.1224]	Q.1224 Distributed Functional Plane for Intelligent Network CS-2, 1997	52
		53
[V.24]	V.24 List of Definitions for Interchange Circuits between Data Terminal Equipment (DTE) and Data Circuit-terminating Equipment (DCE), 2000	54
		55
[X.25]	X.25 Interface Between DTE And DCE For Terminals Operating In The Packet Mode And Connected To Public Data Networks By Dedicated Circuit, 1996	56
		57
		58
[X.200]	X.200 Series of Documents, 1994	59
		60

1 ISO (International Organization for Standardization):

- 2 [ISO/IEC-7776] ISO-7776 X.25 LAPB Compatible DTE Data Link Procedures, 1995
- 3
- 4 [ISO/IEC-8208] ISO-8208 X.25 Packet Layer Protocol for Data Terminal Equipment, 2000
- 5
- 6 [ISO/IEC-8878] ISO-8878 Use Of X.25 To Provide The OSI Connection-Mode Network
- 7 Service, 1992
- 8

9

10 ATIS Standards (Alliance for Telecommunications Industry Solutions):

- 11
- 12 [T1.111] ANSI T1.111-2001 Signaling System Number 7 - Message Transfer Part
- 13 (MTP)
- 14
- 15 [T1.112] ANSI T1.112-2001 Signaling System Number 7 - Signaling Connection
- 16 Control Part (SCCP)
- 17
- 18 [T1.114] ANSI T1.114-1988 Signaling System Number 7 - Transaction Capabilities
- 19 Application Part (TCAP)
- 20
- 21 [T1.209] ANSI T1.209-2003 Operations, Administration, Maintenance, and
- 22 Provisioning (OAM&P) - Network Tones and Announcements; American
- 23 National Standards Institute, Inc.
- 24
- 25 [T1.610] ANSI T1.610-1998 (R 2003) Generic Procedures for the Control of ISDN
- 26 Supplementary Services; American National Standards Institute, Inc.
- 27
- 28 [T1.611] ANSI T1.611-1991(R 2003) Signaling System Number 7 (SS7) -
- 29 Supplementary Services for Non-ISDN-Subscribers American National
- 30 Standards Institute, Inc.
- 31
- 32 [T1.660] ANSI T1.660-1998 (R 2003) American National Standard for
- 33 Telecommunications - Signaling System No. 7 (SS7) Call Completion to a
- 34 Portable Number

35 TIA/EIA (Telecommunications Industry Association/Electronics Industry Alliance):

- 36
- 37 [ANSI-664] 3GPP2: S.R0006, Cellular Features Description; December 1999
- 38
- 39 TIA: TIA-664-A Cellular Features Description; July 2000
- 40
- 41 TTC: JP-3GB S.R0006, Cellular Features Description
- 42
- 43 [ANSI-93] TIA/EIA-93-B Wireless Radio Telecommunications Ai - Di Interfaces
- 44 Standard; July 2001
- 45
- 46 [IS-41-C] TIA/EIA-IS-41-C Cellular Radiotelecommunications Intersystem
- 47 Operations, January 1996
- 48
- 49 [ANSI-41]
- 50 [TIA-41] 3GPP2: N.S0005, Cellular Radiotelecommunications Intersystem Operations
- 51
- 52 TIA: TIA/EIA-41-D Cellular Radiotelecommunications Intersystem
- 53 Operations; December, 1998
- 54
- 55 CCSA: YD/T-1031-1999, Cellular Radiotelecommunications Intersystem
- 56 Operations
- 57
- 58 TTA: TTAE.3G-N.S0005, Cellular Radiotelecommunications Intersystem
- 59 Operations
- 60

[IS-728]	3GPP2: N.S0019, Intersystem Link Protocol	1
	TIA: IS-728, Intersystem Link Protocol; January 2002	2
	TTA: TTAE.3G-N.S0019, Intersystem Link Protocol	3
	TTC: JP-3GB-N.S0019, Intersystem Link Protocol	4
[TSB29]	3GPP2: N.S0017-B, International Implementation of Wireless Telecommunication Systems Compliant with TIA/EIA-41; December 2002	5
	TIA: TSB29-E, International Implementation of Wireless Telecommunication Systems Compliant with TIA/EIA-41; December 2002	6
	TTC: TS-3GB-N.S0017-B v1.0, International Implementation of Wireless Telecommunication Systems Compliant with TIA/EIA-41; December 2002	7
[TSB100]	3GPP2: N.S0005-B, Network Reference Model for cdma2000 Spread Spectrum Systems; May 2001	8
	TIA: TSB100-A, Wireless Network Reference Model (NRM); March 2001	9
	TTC: TS-3GB-S.R0005-Bv1.0, Network Reference Model for cdma2000 ^{®1} Spread Spectrum Systems	10
[TIA/EIA-232]	TIA/EIA-232-F Telecommunications Industry Association Interface Between DTE and DCE Employing Serial Binary Data Interchange; October 1997	11
AMPS (Telecommunications Industry Association):		12
[ANSI-553]	TIA/EIA-553-A Mobile Station - Base Station Compatibility Standard; November 1999	13
CDMA (Telecommunications Industry Association):		14
[ANSI-97]	TIA/EIA/IS-97-D Recommended Minimum Performance Standards for Base Stations Supporting Dual-Mode Spread Spectrum Cellular Mobile Stations; June 2001	15
[IOS]	3GPP2: A.S0001-A, 3GPP2 Access Network Interfaces Interoperability Specification (3G-IOS v4.1.0) Revision A; November 2001	16
	TIA: IS-2001-A, Interoperability Specifications (IOS) for cdma2000 Access Network Interfaces; August 2001	17
	CCSA: CCSA-MC-A.S0001-A, 3GPP2 Access Network Interfaces Interoperability Specification (3G-IOS v4.1.0) Revision A	18

¹ cdma2000[®] is the trademark for the technical nomenclature for certain specifications and standards of the Organizational Partners (OPs) of 3GPP2. Geographically (and as of the date of publication), cdma2000[®] is a registered trademark of the Telecommunications Industry Association (TIA-USA) in the United States.

- 1 [IS-637] 3GPP2: C.S0015-A, Short Message Service (SMS) for Wideband Spread
2 Spectrum Systems, Release A; January 2002
3
4 ARIB: STD-T64-C.S0015-A, Short Message Service (SMS) for Wideband
5 Spread Spectrum Systems, Release A
6
7 TIA: TIA/EIA/IS-637-A, Short Message Services for Wideband Spread
8 Spectrum Cellular System; September 1999
9
- 10 [TSB58] 3GPP2: C.R1001-D, Administration of Parameter Value Assignments for
11 cdma2000 Spread Spectrum Standards; April 2003
12
13 ARIB: STD-T64-C.R1001-D, Administration of Parameter Value
14 Assignments for cdma2000 Spread Spectrum Standards
15
16 TIA: TSB58-D, Administration of Parameter Value Assignments for
17 cdma2000 Spread Spectrum Standards; May 2001
18
- 19 [IS-683] 3GPP2: C.S0016-A, Over-the-Air Service Provisioning of Mobile Stations in
20 Spread Spectrum Systems; December 2001
21
22 ARIB: STD-T64-C.S0016-Av2, Over-the-Air Service Provisioning of
23 Mobile Stations in Spread Spectrum Systems
24
25 TIA: TIA/EIA/IS-683-B, Over-the-Air Service Provisioning of Mobile
26 Stations in Spread Spectrum Systems; December 2001
27
- 28 [IS-95-B] TIA/EIA-95-B - Mobile Station-Base Station Compatibility Standard for
29 Dual-Mode Spread Spectrum Systems; March 1999
- 30 [IS-707] 3GPP2: C.S0017 v5.0, Data Service Options for Wideband Spread Spectrum
31 Systems; February 2002
32
33 ARIB: STD-T64-C.S0017-0-3, Data Service Options for Wideband Spread
34 Spectrum Systems; April 1999
35
36 TIA: TIA/EIA/IS-707-A, Data Service Options for Wideband Spread
37 Spectrum Systems; April 1999
38
- 39 [IS-2000] 3GPP2: C.S0001-A, cdma2000 Series; July 2000
40
41 TIA: TIA/EIA/IS-2000-A, cdma2000 Series; March 2000, plus addenda
42

43 DMH (Telecommunications Industry Association):

- 44 [ANSI-124]
45 [DMH] 3GPP2: N.S0026-A, Wireless Radio Telecommunication Intersystem
46 [DMH] Non-Signaling Data Communication DMH; December 2001
47
48 TIA: ANSI/TIA/EIA-124-D Wireless Radio Telecommunications
49 Intersystem Non-Signaling Data Communication DMH (Data Message
50 Handler); December 2001
51

52 LAES (Telecommunications Industry Association and Alliance for Telecommunications Industry
53 Solutions):

- 54 [ANSI
55 /J-STD-025-A] ANSI/J-STD-025-A Lawfully Authorized Electronic Surveillance: April
56 2003
57
58
59
60

NAMPS (Telecommunications Industry Association):

- [IS-91] TIA/EIA/IS-91 Mobile Station - Base Station Compatibility Standard for 800 MHz Analog Cellular; Telecommunications Industry Association; November 1999

TDMA (Telecommunications Industry Association):

- [TIA/EIA-136] TIA/EIA-136-D. TDMA Third Generation Wireless, April 2002
- [ANSI-627] TIA/EIA-627 800 MHz Cellular System, TDMA Radio Interface, Dual Mode Mobile Station - Base Station Compatibility Standard. April 1996
- [IS-641] TIA/EIA IS-641 800 MHz Cellular System, TDMA Radio Interface, Enhanced Full Rate Speech Codec. March 1996
- [136-720] TIA/EIA-136-720-A-1, TDMA/PCS Over-the-Air Activation Teleservice (OATS); Telecommunications Industry Association; 2000
- [136-730] TIA/EIA-136-730, Over-the-Air Programming Teleservice (OPTS); Telecommunications Industry Association; 2000

1
2
3
4
5
6
7
8
9
10
11
12
13
14
15
16
17
18
19
20
21
22
23
24
25
26
27
28
29
30
31
32
33
34
35
36
37
38
39
40
41
42
43
44
45
46
47
48
49
50
51
52
53
54
55
56
57
58
59
60

2.3.2 Informative References

NoLECN (Telcordia):

SR-TSV-002275 Notes on the LEC Networks; Bell Communications Research, Inc.; April 1994

N-ISDN (Telcordia):

TR-NWT-000776 Network Interface Description for National ISDN-1 Customer Access; Bell Communications Research, Inc.; August 1993

CTIA (Cellular Telecommunications & Internet Association):

CTIA Report on Wireless Number Portability; Version 2.0; Cellular Telecommunications Industry Association; July 7 1998

FCC (Federal Communications Commission):

CC Docket No. 95-116, Second Report and Order, Federal Communications Commission 1997

3 DEFINITIONS AND DOCUMENTATION CONVENTIONS

3.1 DEFINITIONS

Activation MIN

In CDMA OTASP, an Activation_MIN is allocated by the Over-The-Air Service Provisioning Function (OTAF) or obtained by the OTAF from the Customer Service Center (CSC), for the duration of an OTASP session. It is only used as a reference number for an OTASP call instance. The Activation_MIN does not have to conform to numbering plan guidelines or regulations. It shall, however, be unique for all concurrently active OTASP sessions within a Serving System's *TIA-41* network. When the Activation_MIN is present in a message used for OTASP, it is carried in the MIN parameter of that message.

In TDMA OTASP, an Activation_MIN is supplied by an unactivated mobile station for the duration of an OTASP session. It takes the form NPA-NXX-xxxx, where NPA = 000, and the NXX-xxxx is assigned from the lower digits of a decimal representation of the ESN, as specified in *TDMA*.

Active

The MS is available for call delivery. This state is maintained by the MSC, the VLR and the HLR. (See also Inactive and Unavailable.)

Access Denial Call Treatment

A tone, announcement, or call redirection applied as appropriate.

Adjunct MSC

A Mobile Switching Center (MSC) that is providing adjunct services such as voice response, voice recognition, DTMF tone detection, voice message storage, etc.

Anchor MSC

The Mobile Switching Center (MSC), that is the first to assign a traffic channel to a call on origination or termination is called the Anchor MSC. For the duration of this call, this MSC shall be the anchor (fixed) point in the event that the Mobile Station (MS) should be handed off to other MSCs.

American National Standards Institute (ANSI)

The American National Standards Institute (ANSI) is a private, non-profit organization (501 (c) 3) that administers and coordinates the U.S. voluntary standardization and conformity assessment system.

Available

The MS can accept a call delivery (i.e., the MS is in a known location and it is in a state able to accept call deliveries). The availability of a MS to accept a call delivery is maintained only by the MSC. (See also Active, Inactive and Unavailable.)

Band

A group of radio traffic channels reserved for the use of wireless service providers within a given service area.

Band Class

A set of frequency channels and a numbering scheme for these channels.

Base Station Manufacturer Code (BSMC)

An indicator that uniquely identifies the manufacturer of the Base Station equipment. It allows a Mobile Station to acquire services offered by a specific vendor's Base Station. See *TIA/EIA-136*.

Call Delivery

The process by which calls directed to the cellular subscriber are delivered to the subscriber while roaming in a visited system.

Call Delivery Method

Method by which a call is delivered to a subscriber in Visited System.

Call Disconnect

The process of requesting the release of a connection between two or more network addresses.

Call Release

The process of relinquishing the facilities and circuits used for a call.

Call Termination

The process of connecting a subscriber to an incoming call.

Callback Number

The Directory Number (e.g., MDN) provided to the PSAP to call back the Emergency Services Caller.

Candidate MSC

An MSC that is being requested to provide its best CELL ID and SIGNAL QUALITY values during handoff measurement.

Cell Site

The physical location of a cell's radio equipment and supporting systems. This term is also used to refer to the equipment located at the cell site.

Clearinghouse

A service used for the exchange and management of information.

Control Channel Mode (CCM)

An indicator that uniquely identifies the last known Control Channel (Analog or Digital) used by an MS to access the system.

Data Communications

The digital transmission of information (other than voice).

Default Routing

Routing based on the called number, in the absence of number portability information.

Destination Address

SMS address of network element to which an SMDPP is addressed. Sometimes a SME address may be used to allow routing to a network element (e.g., MDN or MSID used with global title routing).

Dialogue

A user interaction sequence composed of tones and announcements that may gather information.

Directory Number (DN)

A telephone network routing address for a subscriber terminal, often simply referred to as the telephone number.

Donor

The switch from which a ported DN was originally ported.

Emergency Services Call

A call requiring connection to a PSAP. The digits 9-1-1 require this treatment in the United States.

Emergency Services Network Entity

An entity which serves as an Emergency Services point of interface to an MSC (e.g., S/R, PSAP).

Emergency Services Routing Digits

A digit string that uniquely identifies a base station, cell site or sector. This number may also be a network routeable number (but not necessarily a dialable number).

Forced Handoff

Mobile Station handoffs performed with only the use of serving system signal strength measurements (e.g., without the use of the Mobile Assisted Handoff (MAHO) function or the HandoffMeasurementRequest (HANDMREQ) operation).

Frequency Block

A set of frequency channels within a Band Class indicated by a Frequency Block Designator (e.g., A, B, C, D, E, F).

Full TMSI

The combination of TMSI zone and TMSI code. It is a globally unique address for the MS.

Full TMSI Timer

The full-TMSI timer is used to automatically design the assigned TMSI when the MS roams into a different TMSI zone. The MS starts the full-TMSI timer whenever it first accesses the system in a new TMSI zone. If the timer expires before a new TMSI is assigned, the MS deletes the TMSI and registers again using the IMSI.

Gateway MSC (MSC-G)

An MSC that is capable of the Intersystem procedures, defined in this document, between entities in the network reference model so as to provide service.

Home Location Register (HLR)

See *TSB-100* (NRM).

Home MSC (MSC-H)

The MSC which is broadcasting the SID that is recorded in the MS's Security and Identification memory, and to which the MS's Directory Number is assigned.

Home System

The system which is transmitting the System Identifier (SID) (refer to *ANSI-553*) which is recognized by the MS as the "Home" SID.

HyperBand

A collection of bands within a frequency range, i.e. 800 MHz and 1800 MHz.

International Mobile Subscriber Identity (IMSI)

The IMSI is a string of decimal digits, up to a maximum of 15 digits, that identifies a unique mobile terminal or mobile subscriber internationally. The IMSI consists of three fields: the mobile country code, the mobile network code, and the mobile subscriber identification number.

Inactive

The MS is not available for call delivery. The MS may not be registered. The MS may be registered, but is out of radio contact (e.g., missing autonomous registrations) or is intentionally inaccessible for periods of time (e.g., slotted mode, paging frame class, or sleep mode). An inactive MS may accept SMS message deliveries. This state is maintained by the MSC, the VLR and the HLR. (See also Active and Unavailable.)

Location Routing Number (LRN)

A network routing address (e.g., 10-digit NANP formatted number) assigned to uniquely identify a switch that serves ported numbers.

Market Identification (MarketID)

A unique market identifier that is specified by the service provider (e.g., FCC assigned SID, CIBERNET assigned BID - see *TSB29*).

Mobile Assisted Handoff (MAHO)

A process where handoff measurements are done by the MS under the control of the MSC and Base Station. The MSC and Base Station retain the control over when the handoff actually occurs.

Mobile Directory Number (MDN)

A directory number assigned to a mobile subscriber.

1 **Mobile Station (MS)**

2
3 See *TSB-100* (NRM).
4

5 **Mobile Station Identity (MSID)**

6
7
8 The identifier for an MS, which may be the MIN or IMSI.
9

10 **Mobile Switching Center (MSC)**

11
12 See *TSB-100* (NRM).
13

14 **Negative List**

15
16 A short list of unacceptable system identifications that is stored in the memory of the MS.
17

18 **Network Identification (NID)**

19
20 A number that uniquely identifies a network within a wireless system.
21

22 **Network Reference Model**

23
24 The functional entities and the associated interface reference points that may logically comprise a
25 cellular network. (See *TSB100*).
26

27 **NetworkTMSI**

28
29 The full TMSI transported over the *ANSI-41* network. The NetworkTMSI is mapped to the
30 subscriber's MIN or IMSI at either the Serving VLR, or the prior Serving VLR.
31

32 **Number Portability Database (NPDB)**

33
34 A network entity containing associations between ported numbers and their Location Routing
35 Numbers (LRNs).
36

37 **Original Destination Address**

38
39 Identifies the SME to which a short message is being sent.
40

41 **Original Originating Address**

42
43 Identifies the SME which initiated a short message and allows responses (e.g. MDN for MS-based
44 SME).
45

Originating Address

SMS address of network element sending an SMDPP.

Originating MSC

The MSC-H or MSC-G that initiates the call delivery procedures defined in this document.

Originating SMS supplementary service

Services or features that affect SMS message originations and are requested on a per message basis as supported by a particular teleservice, for example, delayed delivery, or message distribution to a list of destinations.

OTASPCallEntry

The OTASPCallEntry is a name created to represent an implementation dependent temporary call record used during an OTASP or OTAPA session. Depending on the implementation, the OTASPCallEntry may exist at one or more of the following network entities: HLR, AC, MSC or VLR. Conceptually, the OTASPCallEntry may be identified by either the ESN, or, alternately the Activation MIN, for OTASP, or, for OTAPA, the MS's MIN at the start of the OTAPA session. The OTASPCallEntry may be used to store temporary OTASP or OTAPA session related information (e.g. A-key, SSD, another network entity's SS7 address, etc).

OTASP Data Message

The OTASP Data Message is an OTASP related air-interface message.

Over-The-Air (OTA)

Operations that assist in the administration and provisioning of MS's using over-the-air techniques. See OTAPA and OTASP.

Over-The-Air Parameter Administration (OTAPA)

Over-The-Air Parameter Administration is a network capability that can be used by a service provider to update the NAM or other operational parameters in a subscriber's activated OTAPA capable Mobile Station (MS) over-the-air. OTAPA sessions are initiated autonomously by the network, and proceed without any subscriber involvement or knowledge and with no limitation on the subscriber's ability to receive telecommunications services.

Over-The-Air Service Provisioning (OTASP)

The Over the Air Service Provisioning (OTASP) allows a potential wireless service subscriber to activate (i.e., become authorized for) new wireless service, and allows an existing wireless subscriber to make changes in existing services without the intervention of a third party.

Paging Frame Class (PFC)

The number of Hyperframes over which an MS has a single instance of Paging Channel allocation, therefore allowing the MS to “sleep”. See *TIA/EIA-136*.

Portable Number

A Directory Number (DN) that is part of a portable range (e.g. NPA-NXX) from which one or more DNs may have been ported. A Portable Number is not necessarily a Ported Number.

Ported Number

A Directory Number (DN) that has been ported (e.g. moved) from one service provider to another. A Ported Number is also a Portable Number.

Ported Number Translation Indicator

An indicator within the ISUP Forward Call Indicator (i.e. the M bit) that is set to indicate that the query to a Number Portability DataBase (NPDB) has been successfully performed, or that one is not needed (e.g. intersystem termination to a TLDN). The Ported Number Translation Indicator is used by subsequent switches to prevent extraneous NPDB queries.

Private System ID (PSID)

A non-public (private) system identifier that is only accessible by authorized users. See SID and *TIA/EIA-136*.

Protocol Extension

A mechanism provided to allow systems with a common bilateral agreement to extend the *TIA-41* protocol. There is a range of reserved Error Codes, Operation Codes, Parameter Identifiers (in addition to PRIVATE Parameter Identifiers), and ranges of values in enumerated parameter types and data fields. The only mechanism to resolve conflicting uses of protocol extension is to standardize their usage. The Protocol Extension mechanism is used at the risk of the implementation. Protocol Extensions should not be used unless the message recipient is known to support them.

Public Safety Answering Point (PSAP)

An emergency services network element that is responsible for answering emergency calls.

Recipient

The switch to which a Ported Number has been ported.

Registered

The HLR has a pointer to a system serving an MS. A registered MS may be active or inactive.

Registration

The procedure by which a MS becomes listed as being present in the service area of an MSC.

Remote Feature Control Port (RFC Port)

A terminating directory number supporting service profile modification.

Residential System Identifier (RSID)

A non-public system identifier that is only accessible by users on a residential system. See SID and *TIA/EIA-136*.

Roamer Port

A terminating directory number supporting call delivery to mobile stations.

Roamer Service Profile

The specific set of features, capabilities and/or operating restrictions, other than financial accountability, associated with the subscriber.

Roamer Validation

That aspect of roamer service qualification dealing with financial accountability. Also, the general procedure by which a roamer's financial accountability is established.

Rsvd

Reserved.

Selective Router (S/R)

An emergency services network element that is responsible for routing incoming emergency calls to the appropriate PSAP, and may be responsible for other functions, such as redirecting calls from a primary PSAP to a secondary PSAP. The specification of Selective Router functionality is outside the scope of this document.

Service Qualification

The service capabilities, features and privileges to which an MS is entitled. Also, the general procedure by which such service capabilities, features, and privileges become established in an MSC.

Serving MSC

The MSC which currently has the MS obtaining service at one of its cell sites within its coverage area.

Signaling

The information exchanged between the mobile station and the network, or within the network, for the purposes of service provision (e.g. connection establishment).

System Identification (SID)

A mandatory system identifier that shall be broadcast by a Base Station.

System Operator Code (SOC)

An indicator that uniquely identifies the System Operator. It allows a Mobile Station to acquire services offered by a specific System Operator. See *TIA/EIA-136*.

Switch Number (SWNO)

A number uniquely identifying a particular switch (i.e. a group of cell sites and the associated switch resources) within a group of switches associated with a common MarketID.

Tandem

An intermediate switch (e.g. Access Tandem) that has normal PSTN routing capabilities, and is not performing the selective routing function for an Emergency Services Call.

Tandem MSC

An MSC in a handoff chain intermediate between the Anchor MSC and the Serving MSC.

Target MSC

The MSC that was selected from the candidate list as having the cell site with the best signal quality value for the MS during the handoff measurement request function.

Temporary Local Directory Number (TLDN)

A network address temporarily assigned for call setup.

Temporary Mobile Station Identity (TMSI)

An identification number assigned to an MS on a temporary basis by a serving system (e.g. MSC or VLR).

Terminating SMS supplementary service

Services or features that affect SMS message terminations, for example, screening, forwarding, delivery to an MS, delayed delivery while roaming, or distribution to a group based upon a destination address.

Termination Address

One or more digits, as determined by the Home System, which identify the Terminating Party. This could include Speed Call Codes (when supported by the Home Service Provider), other Mobile Telephone Numbers or any valid World Telephone Number.

TMSI Code

A temporarily assigned MS identification of length up to 32-bits within a TMSI Zone. A TMSI with only a TMSI Code will not provide a globally unique address for an MS.

TMSI Expiration Time

The TMSI expiration time is used to automatically deassign the assigned TMSI. It allows a TMSI to be reassigned periodically and prevents an MS from "holding" a TMSI during extended periods of inactivity. It also helps protect against inadvertent VLR faults which would result in duplicate TMSI assignments. The MS obtains the expiration time value in the message which assigns the TMSI. If the expiration time has passed, the MS deletes the TMSI and uses the IMSI as its identification.

TMSI Zone

The administrative area that allows the TMSI Code to be reused. The TMSI Code is unique only within a TMSI Zone and may be reused in a different TMSI Zone. A TMSI consisting of both the TMSI Zone and TMSI Code provides a globally unique address of an MS.

Traffic

The information generated by the subscriber that is transported on the network (i.e. user voice or data).

Unavailable

The MS cannot accept a normal call delivery (i.e. the MS is in an unknown location or it is in a state unable to accept call deliveries). The availability of an MS to accept a call delivery is maintained only by the MSC. (See also Active and Inactive.)

Unregistered

A state where the MS is unavailable for any type of termination event and the HLR pointer is not directed to any visited system.

User Group (UG)

A limited number of subscribers associated by a common Directory Number, that can be alerted simultaneously when registered as group members.

User Zone (UZ)

An entity specified by associated PSIDs, RSIDs, SIDs or NIDs that may offer differentiating services or flavors of services beyond those offered by the Public System.

Visited MSC (MSC-V)

A “visited” MSC in whose service area a roamer is operating.

Visited System

From the MS’s perspective, a system which is transmitting a SID which is not recognized by the MS as the “Home” SID. From a network perspective, the system in which an MS is currently registered.

Visitor Location Register (VLR)

See *TSB-100* (NRM).

XOREDSSD

The value that represents the Shared Secret Data (SSD-A) XORed with the MS's A-key.

1
2
3
4
5
6
7
8
9
10
11
12
13
14
15
16
17
18
19
20
21
22
23
24
25
26
27
28
29
30
31
32
33
34
35
36
37
38
39
40
41
42
43
44
45
46
47
48
49
50
51
52
53
54
55
56
57
58
59
60

4 SYMBOLS AND ABBREVIATIONS

Table 2 Symbols and Abbreviations

Symbol or Abbreviation	Meaning
3WC	Three Way Calling
A/D	Analog to Digital
AAV	AuthenticationAlgorithmVersion parameter
ABDGTS	DMH_AlternateBillingDigits parameter
AC	Authentication Center
ACCDEN	AccessDeniedReason parameter
ACDGTS	DMH_AccountCodeDigits parameter
ACF	Authentication Control Function
ACK	Positive Acknowledgment Signal
ACSE	Association Control Service Element
ACT	Active
ACTCODE	ActionCode parameter
ADFT	Authentication Directive Forward Timer
ADS	Asynchronous Data Service
ADT	Authentication Directive Timer
AE	Application Entity
AFREPORT	AuthenticationFailureReport INVOKE
afreport	AuthenticationFailureReport RETURN RESULT
AFRT	Authentication Failure Report Timer
AKEYPV	AKeyProtocolVersion parameter
ALERTIME	AlertTime parameter
ALRTCODE	AlertCode parameter
ALRTRES	AlertResult parameter
AMPS	Advanced Mobile Phone System
ANALOGRI	AnalogRedirectInfo parameter
ANALOGRR	AnalogRedirectRecord parameter
ANI	Automatic Number Identification
ANLYZD	AnalyzedInformation INVOKE
anlyzd	AnalyzedInformation RETURN RESULT
ANNCODE	AnnouncementCode parameter
ANNLIST	AnnouncementList parameter
ANSI	American National Standards Institute
ANZT	Analyzed Information Timer
AON	AllOrNone parameter

Symbol or Abbreviation	Meaning
APDU	Application Protocol Data Unit
ART	Authentication Request Timer
ASE	Application Service Element
ASN.1	Abstract Syntax Notation One
ASP	Application Service Part
ASR	Automatic Speech Recognition
ASREPORT	AuthenticationStatusReport INVOKE
asreport	AuthenticationStatusReport RETURN RESULT
ASRRRT	Authentication Status Report Response Timer
ASRT	Authentication Status Report Timer
ATIS	Alliance for Telecommunications Industry Solutions
AUTH	AuthenticationIndicator parameter
AUTHBS	AuthenticationResponseBaseStation parameter
AUTHCAP	AuthenticationCapability parameter
AUTHDATA	AuthenticationData parameter
AUTHDEN	AuthorizationDenied parameter
AUTHDIR	AuthenticationDirective INVOKE
authdir	AuthenticationDirective RETURN RESULT
AUTHDIRFWD	AuthenticationDirectiveForward INVOKE
authdirfwd	AuthenticationDirectiveForward RETURN RESULT
AUTHPER	AuthorizationPeriod parameter
AUTHR	AuthenticationResponse parameter
AUTHRA	AuthenticationResponseReauthentication parameter
AUTHREQ	AuthenticationRequest INVOKE
authreq	AuthenticationRequest RETURN RESULT
AUTHU	AuthenticationResponseUniqueChallenge parameter
AVTYP	AvailabilityType parameter
BCD	Binary Coded Decimal
BCM	Basic Call Manager
BCSM	Basic Call State Model
BDT	Bulk Deregistration Timer
BER	Basic Encoding Rules
BID	Billing System Identifier
BILLDGTS	DMH_BillingDigits parameter
BILLID	BillingID parameter
BLKT	Blocking Timer
BLOCKING	Blocking INVOKE

Symbol or Abbreviation	Meaning
blocking	Blocking RETURN RESULT
BORDACC	BorderCellAccess parameter
BS	Base Station
BSCHALL	BaseStationChallenge INVOKE
bschall	BaseStationChallenge RETURN RESULT
BSCT	Base Station Challenge Timer
BSKEY	BaseStationPartialKey parameter
BSMC	BaseStationManufacturerCode (parameter)
BSMCS	BSMCStatus parameter
BULKDEREG	BulkDeregistration INVOKE
bulkdereg	BulkDeregistration RETURN RESULT
c2KHINVID	CDMA2000HandoffInvokeIOSData parameter
c2KHRSPID	CDMA2000HandoffResponseIOSData parameter
c2KMSC	CDMA2000MobileSupportedCapabilities parameter
CANDEN	CancellationDenied parameter
CANTYP	CancellationType parameter
CARDGTS	CarrierDigits parameter
CAVE	Cellular Authentication and Voice Encryption
CC	Conference Calling
CCDATA	ControlChannelData parameter
CCF	Call Control Function
CCI	ConferenceCallingIndicator parameter
CCITT	International Telegraph and Telephone Consultative Committee
CCM	ControlChannelMode parameter
CCPN	Call Completion to a Portable Number
CCS7	Common Channel Signaling #7
CD	Call Delivery
CDEN	ConditionallyDeniedReason parameter
CDMA	Code Division Multiple Access
CDMABC	CDMABandClass parameter
CDMABCI	CDMABandClassInformation parameter
CDMABCL	CDMABandClassList parameter
CDMACHAN	CDMACodeChannel parameter
CDMACHINFO	CDMACodeChannelInformation parameter
CDMACHLIST	CDMACodeChannelList parameter
CDMACN	CDMAChannelNumber parameter
CDMACNL	CDMAChannelNumberList parameter

Symbol or Abbreviation	Meaning
CDMACR	CDMAConnectionReference parameter
CDMACRINFO	CDMAConnectionReferenceInformation parameter
CDMACRLIST	CDMAConnectionReferenceList parameter
CDMADATA	CDMAChannelData parameter
CDMAMAHO	CDMATargetMAHOInformation parameter
CDMAMAHOLIST	CDMATargetMAHOList parameter
CDMAMEAS	CDMATargetMeasurementInformation parameter
CDMAMEASLIST	CDMATargetMeasurementList parameter
CDMAMODE	CDMACallMode parameter
CDMAMPR	CDMAMobileProtocolRevision parameter
CDMAMSMCI	CDMAMSMMeasuredChannelIdentity parameter
CDMANID	CDMANetworkIdentification parameter
CDMAPCI	CDMAPowerCombinedIndicator parameter
CDMAPILOT	CDMAPilotStrength parameter
CDMAPLCM	CDMAPrivateLongCodeMask parameter
CDMAPPN	CDMAPilotPN parameter
CDMAQUAL	CDMASignalQuality parameter
CDMARR	CDMARedirectRecord parameter
CDMAS	CDMAState parameter
CDMASCII	CDMASlotCycleIndex parameter
CDMASCMM	CDMAStationClassMark parameter
CDMASCMM2	CDMAStationClassMark2 parameter
CDMASCR	CDMAServiceConfigurationRecord parameter
CDMASO	CDMAServiceOption parameter
CDMASOL	CDMAServiceOptionList parameter
CDMASOWD	CDMAServingOneWayDelay parameter
CDMASP	CDMASearchParameters parameter
CDMASWIN	CDMASearchWindow parameter
CDMATOWD	CDMATargetOneWayDelay parameter
CDRT	Call Data Request Timer
CFB	Call Forwarding—Busy
CFD	Call Forwarding—Default
CFI	CallingFeaturesIndicator parameter
CFNA	Call Forwarding—No Answer
CFRT	Connection Failure Report Timer
CFU	Call Forwarding—Unconditional
CGNAME	CallingPartyName parameter

Symbol or Abbreviation	Meaning
CGSA	Cellular Geographical Service Area
CHANGE	Change parameter
CHDATA	ChannelData parameter
CHGFAC	ChangeFacilities INVOKE
chgfac	ChangeFacilities RETURN RESULT
CHGSERV	ChangeService INVOKE
chgserv	ChangeService RETURN RESULT
CHGSRVAT	ChangeServiceAttribute parameter
CHNO	Channel Number
CM	ConnectionManagement parameter
CMAC	Control Mobile Attenuation Code
CMDCODE	CommandCode parameter
CMODES	ConfidentialityModes parameter
CNA	Calling Name Identification
CNAP	Calling Name Presentation
CNAR	Calling Name Restriction
CNI	Calling Number Identification
CNIP	Calling Number Identification Presentation
CNIR	Calling Number Identification Restriction
CONNFAILRPT	ConnectionFailureReport INVOKE
CONNRES	ConnectResource INVOKE
COUNT	CallHistoryCount parameter
COUNTEx	CallHistoryCountExpected parameter
COUNTREQ	CountRequest INVOKE
countreq	CountRequest RETURN RESULT
COUNTRPT	CountUpdateReport parameter
CPNDGTS1	CallingPartyNumberDigits1 parameter
CPNDGTS2	CallingPartyNumberDigits2 parameter
CPNSTRG1	CallingPartyNumberString1 parameter
CPNSTRG2	CallingPartyNumberString2 parameter
CPSUB	CallingPartySubaddress parameter
CRM	Circuit Reservation Message
CRT	Count Request Timer
CS-2	Capability Set 2
CSC	Customer Service Center
CT	Call Transfer
CTT	Clear Trunk Timer

Symbol or Abbreviation	Meaning
CW	Call Waiting
C_SOI	CDMAServiceOptionConnectionIdentifier parameter
DADS	Digital Asynchronous Data Service
DAE	DataAccessElement parameter
DAEL	DataAccessElementList parameter
DATAID	DataID parameter
DATAKEY	DatabaseKey parameter
DATARES	DataResult parameter
DATAVAL	DataValue parameter
DATUR	DataUpdateResult parameter
DATURL	DataUpdateResultList parameter
DCC	Digital Color Code
DCE	Data Circuit-Terminating Equipment
DENACC	DenyAccess parameter
DENAUTHPER	DeniedAuthorizationPeriod parameter
DEREG	DeregistrationType parameter
DFP	Distributed Functional Plane
DGTCC	DigitCollectionControl parameter
DGTSDIAL	DigitsDialed parameter
DISCONNRES	DisconnectResource INVOKE
DISPTEXT	DisplayText parameter
DISPTEXT2	DisplayText2 parameter
DKEY	DataKey parameter
DMAC	Digital Mobile Attenuation Code
DMH	Data Message Handling
DN	Directory Number
DND	Do Not Disturb
DP	DataPrivacy parameter
DP	Detection Point
DPC	Destination Point Code
DPP	DataPrivacyParameters parameter
DTE	Data Terminating Equipment
DVCC	Digital Verification Color Code
DXE	Data Terminating or Data Circuit-Terminating Equipment
EC	Exchange Carrier
EDP	Event Detection Point
EDP-N	Event Detection Point - Notification

Symbol or Abbreviation	Meaning
EDP-R	Event Detection Point - Request
EIA	Electronic Industry Association
EIR	Equipment Identity Register
EPERPT	EnhancedPrivacyEncryptionReport parameter
ERP	Effective Radiated Power
ES	Emergency Services
ESN	Electronic Serial Number or ElectronicSerialNumber parameter
ESNE	Emergency Services Network Entity
ESRD	EmergencyServicesRoutingDigits parameter
EXESCR	ExecuteScript parameter
EXTMSCID	ExtendedMSCID parameter
EXTMYTYP	ExtendedSystemMyTypeCode parameter
FA	Flexible Alerting
FACDIR	FacilitiesDirective INVOKE
facdir	FacilitiesDirective RETURN RESULT
FACDIR2	FacilitiesDirective2 INVOKE
facdir2	FacilitiesDirective2 RETURN RESULT
FACREL	FacilitiesRelease INVOKE
facrel	FacilitiesRelease RETURN RESULT
FAILCAUSE	FailureCause parameter
FAILTYPE	FailureType parameter
FAVAIL	FacilitySelectedAndAvailable INVOKE
favail	FacilitySelectedAndAvailable RETURN RESULT
FAVT	Facility Selected And Available Timer
FAX	Facsimile
FC	Feature Code
FE	Functional Entity
FEATREQ	FeatureRequest INVOKE
featreq	FeatureRequest RETURN RESULT
FEATRESULT	FeatureResult parameter
FIM	Feature Interactions Manager
FLASHREQ	FlashRequest INVOKE
flashreq	FlashRequest RETURN RESULT
FM	Feature Manager
FRRT	Feature Request Response Timer
FRT	Flash Request Timer
FSLP	Feature Service Logic Program

Symbol or Abbreviation	Meaning
FU	Functional Unit
GAP	Generic Address Parameter (ISUP parameter)
GEOAUTH	GeographicAuthorization parameter
GRPINFO	GroupInformation parameter
GSL	Global Service Logic
GT	GlobalTitle parameter
GTT	Global Title Translation
HANDBACK	HandoffBack INVOKE
handback	HandoffBack RETURN RESULT
HANDBACK2	HandoffBack2 INVOKE
handback2	HandoffBack2 RETURN RESULT
HANDMREQ	HandoffMeasurementRequest INVOKE
handmreq	HandoffMeasurementRequest RETURN RESULT
HANDMREQ2	HandoffMeasurementRequest2 INVOKE
handmreq2	HandoffMeasurementRequest2 RETURN RESULT
HANDREASON	HandoffReason parameter
HANDTHIRD	HandoffToThird INVOKE
handthird	HandoffToThird RETURN RESULT
HANDTHIRD2	HandoffToThird2 INVOKE
handthird2	HandoffToThird2 RETURN RESULT
HLR	Home Location Register
HLRID	Home Location Register Identification
HLRINFO	HLRInformation
HOSTATE	HandoffState parameter
HOT	Handoff Order Timer
HTTRT	Handoff To Third Result Timer
HTTT	Handoff To Third Timer
IA5	International Alphabet 5 see CCITT Rec. T.50
IAM	Initial Address Message
IC	Interexchange Carrier
ICS	Incoming Call Screening
IDT	Information Directive Timer
IFT	Information Forward Timer
IMSCCID	InterMSCircuitIdentification
IMSI	International Mobile Subscriber Identity or IMSI parameter
IMTIME	InterMessageTime parameter
IN	Intelligent Network

Symbol or Abbreviation	Meaning
INC	International Carrier
INFODIR	InformationDirective INVOKE
infodir	InformationDirective RETURN RESULT
INFOFWD	InformationForward INVOKE
infofwd	InformationForward RETURN RESULT
INSTREQ	InstructionRequest INVOKE
instreq	InstructionRequest RETURN RESULT
IP	Internet Protocol
IP	Intelligent Peripheral
IRT	Instruction Request Timer
ISANSWER	InterSystemAnswer INVOKE
isanswer	InterSystemAnswer RETURN RESULT
ISART	InterSystemAnswer Response Timer
ISAT	InterSystemAnswer Timer
ISCOUNT	InterSwitchCount parameter
ISDN	Integrated Services Digital Network
ISLP	InterSystem Link Protocol
ISLPINFO	ISLPInformation parameter
ISO	International Standards Organization
ISPAGE	InterSystemPage INVOKE
ispage	InterSystemPage RETURN RESULT
ISPAGE2	InterSystemPage2 INVOKE
ispage2	InterSystemPage2 RETURN RESULT
ISPRT	InterSystemPage Request Timer
ISSETUP	InterSystemSetup INVOKE
issetup	InterSystemSetup RETURN RESULT
ISSRT	InterSystemSetup Request Timer
ISSWT	InterSystemSetup Wait Timer
ISTERM	IntersystemTermination parameter
ISUP	ISDN User Part
ITU	International Telecommunications Union
IWF	Interworking Function
LATA	Local Access and Transport Area
LB	Locally Blocked
LEGINFO	LegInformation parameter
LMMRT	Location Measurement Maximum Response Timer
LOCID	LocationAreaID parameter

Symbol or Abbreviation	Meaning
LOCREQ	LocationRequest INVOKE
locreq	LocationRequest RETURN RESULT
LOCTERM	LocalTermination parameter
LRB	Locally and Remotely Blocked
LRF	Location Registration Function
LRFh	Location Registration Function – HLR
LRFv	Location Registration Function – VLR
LRN	Location Routing Number
LRT	Location Request Timer
LSB	Least Significant Bit
MA	Mobile Application
MACF	Mobile Station Access Control Function
MAH	Mobile Access Hunting
MAHO	Mobile Assisted Handoff
MAHT	Mobile Access Hunt Timer
MAP	Mobile Application Part
MAT	Mobile Arrival Timer
MAXHANDOFF	MaximumHandoffCount parameter
MBC	Mandatory for Backward Compatibility
MC	Message Center
MDN	MobileDirectoryNumber parameter
MHOT	Mobile Handoff Order Timer
MHS	Message Handling Systems
MIN	Mobile Identification Number or MobileIdentificationNumber parameter
MIN1	NXX-XXXX of MIN
MIN2	NPA of MIN
MODIFY	Modify INVOKE
modify	Modify RETURN RESULT
MODRES	ModificationResult parameter
MODRQ	ModificationRequest parameter
MODRQL	ModificationRequestList parameter
MODRSL	ModificationResultList parameter
MODVAL	ModulusValue parameter
MS	Mobile Station
MSB	Most Significant Bit
MSC	Mobile Switching Center
MSC-G	Mobile Switching Center—Gateway

Symbol or Abbreviation	Meaning
MSC-H	Mobile Switching Center—Home
MSC-V	Mobile Switching Center—Visited
MSCADDR	MSC_Address parameter
MSCID	MSCID parameter
MSCIN	MSCIdentificationNumber parameter
MSGDIR	MessageDirective INVOKE
msgdir	MessageDirective RETURN RESULT
MSID	Mobile Station Identity or MSID parameter
MSIDUSE	MSIDUsage parameter
MSIMSI	MobileStationIMSI parameter
MSINACT	MSInactive INVOKE
msinact	MSInactive RETURN RESULT
MSIT	MS Inactive Timer
MSKEY	MobileStationPartialKey parameter
MSLOC	MSLocation parameter
MSMIN	MobileStationMIN parameter
MSONCH	MobileOnChannel INVOKE
MS_MSID	MobileStationMSID parameter
MT	Modify Timer
MTP	Message Transfer Part
MWN	Message Waiting Notification parameter
MWNCOUNT	MessageWaitingNotificationCount parameter
MWNTYPE	MessageWaitingNotificationType parameter
MYTYP	SystemMyTypeCode parameter
NACK	Negative Acknowledgment Signal
NAM	NumberAssignment Module
NAMI	Calling Name Capability Indicator
NAMPS	Narrow AMPS
NAMPSMODE	NAMPSCallMode parameter
NANP	North American Numbering Plan
NATIME	NoAnswerTime parameter
NCHDATA	NAMPSCchannelData parameter
NDSS	Network Directed System Selection
NE	Network Entity
NETMSI	NetworkTMSI parameter
NETMSIT	NetworkTMSIExpirationTimer parameter
NEWIMSI	NewlyAssignedIMSI parameter

Symbol or Abbreviation	Meaning
NEWMIN	NewlyAssignedMIN parameter
NEWMINEXT	NewMIN extension parameter
NEWMSID	NewlyAssignedMSID parameter
NID	Network Identity
NNETMSI	NewlyAssignedNetworkTMSI parameter
NOSSD	SSDNotShared parameter
NP	Non-Public Service Mode
NP	Number Portability
NPA	Numbering Plan Area (repeat block Area Code)
NPDATA	NonPublicData parameter
NPDB	Number Portability DataBase
NPREQ	NumberPortabilityRequest INVOKE
npreq	NumberPortabilityRequest RETURN RESULT
NPT	Number Portability Timer
NRM	Network Reference Model
NSAP	Network Service Access Point
NXX	Office Code
O	Optional
OA&M	Operations, Administration, and Maintenance
OATS	Over-The-Air Activation Teleservice (TDMA)
OMT	Overhead Message Train
OPC	Originating Point Code
OPDU	Operation Protocol Data Unit
ORIGIND	OriginationIndicator parameter
ORIGTRIG	OriginationTriggers parameter
ORREQ	OriginationRequest INVOKE
orreq	OriginationRequest RETURN RESULT
ORT	Origination Request Timer
OSI	Open Systems Interconnection
OSSS	Originating SMS Supplementary Service
OTA	Over-The-Air
OTAF	Over-The-Air Service Provisioning Function
OTAPA	Over-The-Air Parameter Administration
OTART _{cx}	OTASP Request Response Timer (CDMA: where x = s, l)
OTART _t	OTASP Request Response Timer (TDMA)
OTASP	Over-the-Air Service Provisioning

Symbol or Abbreviation	Meaning
OTASPRC	OTASP_ResultCode parameter
OTASPREQ	OTASP_Request INVOKE
otaspreq	OTASP_Request RETURN RESULT
OTFI	OneTimeFeatureIndicator parameter
PACA	Priority Access and Channel Assignment
PACAIND	PACAIndicator parameter
PACS	Personal Access Communications System
PAGECOUNT	PageCount parameter
PAGEIND	PageIndicator parameter
PAGETIM	PageResponseTime parameter
PARMREQ	ParameterRequest INVOKE
parmreq	ParameterRequest RETURN RESULT
PAT	PACA Answer Timer
PC	Point Code
PCA	Password Call Acceptance
PCS	Personal Communications Service/System
PC_SSN	PC_SSN parameter
PDN	Public Data Network
PDT	PACA Detection Timer
PDU	Protocol Data Unit
PFC	PagingFrameClass parameter
PFT	PACA Feedback Timer
PIC	Preferred Interexchange Carrier
PIC	Point In Call
PILOT	PilotNumber parameter
PILOTBID	PilotBillingID parameter
PIMM	Point In Mobility Management
PIN	Personal Identification Number
PL	Preferred Language
PLIND	PreferredLanguageIndicator parameter
PN	Pseudo random noise
POI	Point of Interface
PPDU	Presentation Protocol Data Unit
PRIMVAL	PrimitiveValue parameter
PRINFO	PSID/RSIDInformation parameter
PRLIST	PSID/RSIDList parameter
PSAP	Public Safety Answering Point

Symbol or Abbreviation	Meaning
PSID	Private System Identifier
PSTN	Public Switched Telephone Network
PSTNTERM	PSTNTermination parameter
QDT	Qualification Directive Timer
QOS	Quality of Service
QoSPRI	QoSPriority parameter
QRT	Qualification Request Timer
QUALCODE	QualificationInformationCode
QUALDIR	QualificationDirective INVOKE
qualdir	QualificationDirective RETURN RESULT
QUALREQ	QualificationRequest INVOKE
qualreq	QualificationRequest RETURN RESULT
R	Required
RACF	Radio Access Control Function
RAND	RandomVariable parameter
RANDBS	RandomVariableBaseStation parameter
RANDC	RANDC parameter
RANDRA	RandomVariableReauthentication parameter
RANDREQ	RandomVariableRequest INVOKE
randreq	RandomVariableRequest RETURN RESULT
RANDRT	Random Variable Request Timer
RANDSSD	RandomVariableSSD parameter
RANDU	RandomVariableUniqueChallenge parameter
RANDVT	RANDValidTime parameter
RARPT	ReauthenticationReport parameter
RB	Remotely Blocked
RCF	Radio Control Function
RCT	Registration Cancellation Timer
RDNAME	RedirectingPartyName parameter
RDRT	Redirection Request Timer
RDT	Redirection Directive Timer
Rec.	Recommendation
REDDIR	RedirectionDirective INVOKE
reddir	RedirectionDirective RETURN RESULT
REDIND	DMH_RedirectionIndicator parameter
REDREASON	RedirectionReason parameter
REDREQ	RedirectionRequest INVOKE

Symbol or Abbreviation	Meaning
redreq	RedirectionRequest RETURN RESULT
REGCANC	RegistrationCancellation INVOKE
regcanc	RegistrationCancellation RETURN RESULT
REGNOT	RegistrationNotification INVOKE
regnot	RegistrationNotification RETURN RESULT
RELEASE	Release INVOKE
release	Release RETURN RESULT
RELREASON	ReleaseReason parameter
RESETCKT	ResetCircuit INVOKE
resetckt	ResetCircuit RETURN RESULT
RESETTIMER	ResetTimer INVOKE
REST	Reset Timer
RF	Radio Frequency
RFC	Remote Feature Control
RNDGTS	RedirectingNumberDigits parameter
RNSTRING	RedirectingNumberString parameter
RNT	Registration Notification Timer
RO	Remote Operation
ROAMIND	RoamingIndicator parameter
ROUTDGTS	RoutingDigits parameter
ROUTREQ	RoutingRequest INVOKE
routreq	RoutingRequest RETURN RESULT
RPM	RequiredParametersMask parameter
RPTTYP	ReportType parameter
RRT	Routing Request Timer
RSID	Residential System Identifier
RSIGQUAL	ReceivedSignalQuality parameter
RSNLST	ReasonList parameter
RSSI	Received Signal Strength Indication
RSTT	Reset Circuit Timer
RSUB	RedirectingSubaddress parameter
RTF	Radio Terminal Function
RUDT	Remote User Interaction Directive Timer
RUI	Remote User Interaction
RUI-MSC	repeat block MSC capable of Remote User Interaction
RUIDIR	RemoteUserInteractionDirective INVOKE
ruidir	RemoteUserInteractionDirective RETURN RESULT

Symbol or Abbreviation	Meaning
S/R	Selective Router
SADT	SMS Air Delivery Timer
SAOT	SMS Air Origination Timer
SAT	Supervisory Audio Tone
SBI	Shortened Burst Indicator
SBSL	Switch-Based Service Logic
SBT	SMS Delivery Backward Timer
SC	Subscriber Confidentiality
SCA	Selective Call Acceptance
SCC	SAT Color Code
SCCP	Signaling Connection Control Part
SCEF	Service Creation Environment Function
SCCELLID	ServingCellID parameter
SCF	Service Control Function
SCFT	Service Control Function Timer
SCM	StationClassMark parameter
SCP	Service Control Point
SCRARG	ScriptArgument parameter
SCRNAME	ScriptName parameter
SCRRESULT	ScriptResult parameter
SDAE	ServiceDataAccessElement parameter
SDAEL	ServiceDataAccessElementList parameter
SDCC	Supplementary Digital Color Code
SDF	Service Data Function
SDR	ServiceDataResult parameter
SDRL	ServiceDataResultList parameter
SEARCH	Search INVOKE
search	Search RETURN RESULT
SECIMSCCID	SecondInterMSCCircuitID parameter
SEIZERES	SeizeResource INVOKE
seizeres	SeizeResource RETURN RESULT
SEIZTYP	SeizureType parameter
SENDERIN	SenderIdentificationNumber parameter
SERVREQ	ServiceRequest INVOKE
servreq	ServiceRequest RETURN RESULT
SERVRSLT	ServicesResult parameter
SETRESULT	SetupResult parameter

Symbol or Abbreviation	Meaning
SFT	SMS Delivery Forward Timer
SHH	SpecialHandling parameter
SID	System ID
SIGQUAL	SignalQuality parameter
SIM	Service Interactions Manager
SLP	Service Logic Program
SLPI	Service Logic Program Instance
SM	Switching Manager
SMAF	Service Management Access Function
SMD-ACK	ShortMessageDeliveryAcknowledge message
SMD-NACK	ShortMessageDeliveryNegativeAcknowledge message
SMD-REQ	ShortMessageDeliveryRequest message
SMD-REQUEST	ShortMessageDeliveryRequest message
SMDBACK	SMSDeliveryBackward INVOKE
smdback	SMSDeliveryBackward RETURN RESULT
SMDFWD	SMSDeliveryForward INVOKE
smdfwd	SMSDeliveryForward RETURN RESULT
SMDPP	SMSDeliveryPointToPoint INVOKE
smdpp	SMSDeliveryPointToPoint RETURN RESULT
SMDPPACK	SMSDeliveryPointToPointAck INVOKE
SME	Short Message Entity
SMEKEY	SignalingMessageEncryptionKey parameter
SMEM	SignalingMessageEncryptionMode parameter
SMERPT	SignalingMessageEncryptionReport parameter
SMF	Service Management Function
SMS	Short Message Service
SMSACCDEN	SMS_AccessDeniedReason parameter
SMSADDR	SMS_Address parameter
SMSCAUSE	SMS_CauseCode parameter
SMSDPF	SMS_DeliveryPendingFlag parameter
SMSMSGCNT	SMS_MessageCount parameter
SMSMWI	SMS_MessageWaitingIndicator parameter
SMSNOT	SMSNotification INVOKE
smsnot	SMSNotification RETURN RESULT
SMSNOTIND	SMS_NotificationIndicator parameter
SMSREQ	SMSRequest INVOKE
smsreq	SMSRequest RETURN RESULT

Symbol or Abbreviation	Meaning
SMSTERMREST	SMS_TerminationRestrictions parameter
SMSTID	SMS_TeleserviceIdentifier parameter
SMS_TID	SMS_TransactionID parameter
SMT	Short Message Timer
SMT _{cx}	Short Message Delivery Timer (CDMA; where x=s, m, l)
SN	Service Negotiation
SN	Service Node
SNT	SMS Notification Timer
SOC	SystemOperatorCode parameter
SOCS	SOCStatus parameter
SPDT	Service Profile Directive Timer
SPDU	Session Protocol Data Unit
SPINA	Subscriber PIN Access
SPINI	Subscriber PIN Intercept
SPINIPIN	Subscriber PIN Intercept PIN
SPRT	Service Profile Request Timer
SPT	SMS Point-To-Point Timer
SRCAUSE	ServiceRedirectionCause parameter
SRF	Specialized Resource Function
SRFDIR	SRFDirective INVOKE
srfdir	SRFDirective RETURN RESULT
SRFDT	SRF Directive Timer
SRINFO	ServiceRedirectionInfo parameter
SRT	SMS Request Timer
SRVID	ServiceID parameter
SRVIND	ServiceIndicator parameter
SS7	Signaling System 7 (ANSI)
SSD	SharedSecretData parameter
SSD-A	Shared Secret Data-A
SSD-B	Shared Secret Data-B
SSDURPT	SSDUpdateReport parameter
SSF	Service Switching Function
SSFT	Service Switching Function Timer
SSL	Service Specific Logic
SSM	Switching State Model
SSN	Subsystem Number

Symbol or Abbreviation	Meaning
ST	Search Timer
STP	Signaling Transfer Point
STU	Secure Telephone Unit
SUSACC	SuspiciousAccess parameter
SWNO	Switch Number
SYSACCDATA	SystemAccessData parameter
SYSACCTYPE	SystemAccessType parameter
SYSCAP	SystemCapabilities parameter
SZRT	Seize Resource Timer
TA	Termination Address
TANDEMDEPTH	TandemDepth parameter
TAT	TerminationAccessType parameter
TBCD	Telephony Binary Coded Decimal
TBT	TBusy Timer
TBUSY	TBusy INVOKE
tbusy	TBusy RETURN RESULT
TC	Transaction Capabilities
TCAP	Transaction Capabilities Application Part
TCELLID	TargetCellID parameter
TCELLIDLIST	TargetCellIDList parameter
TDD/TTY	Telecommunications Device for the Deaf/Teletypewriter
TDMA	Time Division Multiple Access
TDMABW	TDMABandwidth parameter
TDMADATA	TDMACHannelData parameter
TDMADFI	TDMADataFeaturesIndicator parameter
TDMADM	TDMADataMode parameter
TDMAMODE	TDMACallMode parameter
TDMASBI	TDMABurstIndicator parameter
TDMASC	TDMAServiceCode parameter
TDMAVC	TDMAVoiceCoder parameter
TDO	TimeDateOffset parameter
TDP	Trigger Detection Point
TDP-N	Trigger Detection Point - Notification
TDP-R	Trigger Detection Point - Request
TDT	TMSIDirective timer
TERMCAP	TDMATerminalCapability parameter
TERMLIST	TerminationList parameter

Symbol or Abbreviation	Meaning
TERMRES	TerminationRestrictionCode parameter
TERMTRIG	TerminationTriggers parameter
TERMTRMT	TerminationTreatment parameter
TERMTYP	TerminalType parameter
THTTT	Tandem Handoff To Third Timer
TIA	Telecommunications Industry Association
TLDN	Temporary Local Directory Number
TLDNAT	Temporary Local Directory Number Association Timer
TMEAS	TargetMeasurementInformation parameter
TMEASLIST	TargetMeasurementList parameter
TMSI	Temporary Mobile Station Identity
TMSIDIR	TMSIDirective INVOKE
tmsidir	TMSIDirective RETURN RESULT
TNAT	TNoAnswer Timer
TNOANS	TNoAnswer INVOKE
tnoans	TNoAnswer RETURN RESULT
TPDU	Transport Protocol Data Unit
TRANSCAP	TransactionCapability parameter
TRANUMREQ	TransferToNumberRequest INVOKE
tr anumreq	TransferToNumberRequest RETURN RESULT
TRIGADDRLIST	TriggerAddressList parameter
TRIGCAP	TriggerCapability parameter
TRIGLIST	TriggerList parameter
TRIGTYPE	TriggerType parameter
TRN	TemporaryReferenceNumber parameter
TRNKSTAT	TrunkStatus parameter
TSAP	Transport Service Access Point
TSB	Telecommunications Systems Bulletin
TSR	Time Slot and Rate Indicator
TSSS	Terminating SMS Supplementary Service
TTDT	Trunk Test Disconnect Timer
TTEST	TrunkTest INVOKE
ttest	TrunkTest RETURN RESULT
TTESTDISC	TrunkTestDisconnect INVOKE
ttestdisc	TrunkTestDisconnect RETURN RESULT
TTNRT	Transfer-To Number Request Timer
TTT	Trunk Test Timer

Symbol or Abbreviation	Meaning
UBLKT	Unblocking Timer
UCHALRPT	UniqueChallengeReport parameter
UDT	Unitdata message
UDTS	Unitdata Service message
UG	UserGroup parameter
UGID	User Group ID
UNBLOCKING	Unblocking INVOKE
unblocking	Unblocking RETURN RESULT
UNRELDIR	UnreliableRoamerDataDirective INVOKE
unreldir	UnreliableRoamerDataDirective RETURN RESULT
UNSOLRES	UnsolicitedResponse INVOKE
unsolres	UnsolicitedResponse RETURN RESULT
UPDCOUNT	UpdateCount parameter
URDDT	Unreliable Roamer Data Directive Timer
URT	Unsolicited Response Timer
UZ	User Zone
UZDATA	UserZoneData parameter
VCH	Voice Channel
VCS	Voice Controlled Services
VLR	Visitor Location Register
VMAC	Voice Mobile Attenuation Code
VMBOX	VoiceMailboxNumber parameter
VMN	Voice Mail Number
VMR	Voice Message Retrieval
VMS	Voice Message System
VMSPIN	VoiceMailboxPIN parameter
VP	Voice Privacy
VPM	Voice Privacy Mode
VPMASK	VoicePrivacyMask parameter
VPRPT	VoicePrivacyReport parameter
VRU	Voice Response Unit
VUI	Voice-based User Identification
WIN	Wireless Intelligent Network
WINCAP	WINCapability parameter
WINOPCAP	WINOperationsCapability parameter

1
2
3
4
5
6
7
8
9
10
11
12
13
14
15
16
17
18
19
20
21
22
23
24
25
26
27
28
29
30
31
32
33
34
35
36
37
38
39
40
41
42
43
44
45
46
47
48
49
50
51
52
53
54
55
56
57
58
59
60

Symbol or Abbreviation	Meaning
WINRT	WIN Response Timer
WNP	Wireless Number Portability
WTRIGLIST	WIN_TriggerList parameter
XXXX	Station Number (in context of NPA-NXX-XXXX)

1
2
3
4
5
6
7
8
9
10
11
12
13
14
15
16
17
18
19
20
21
22
23
24
25
26
27
28
29
30
31
32
33
34
35
36
37
38
39
40
41
42
43
44
45
46
47
48
49
50
51
52
53
54
55
56
57
58
59
60

4.1 DOCUMENTATION CONVENTIONS

Each scenario description has two components:

- a scenario diagram, followed by
- a description of each step in the scenario diagram.

Each of these two components employs a set of documentation conventions, described below.

4.1.1 Scenario Diagram Conventions

The scenarios presented in this document use the following diagrammatic conventions to illustrate the information exchange between network entities

1
2
3
4
5
6
7
8
9
10
11
12
13
14
15
16
17
18
19
20
21
22
23
24
25
26
27
28
29
30
31
32
33
34
35
36
37
38
39
40
41
42
43
44
45
46
47
48
49
50
51
52
53
54
55
56
57
58
59
60

Figure 1 Diagrammatic Conventions:

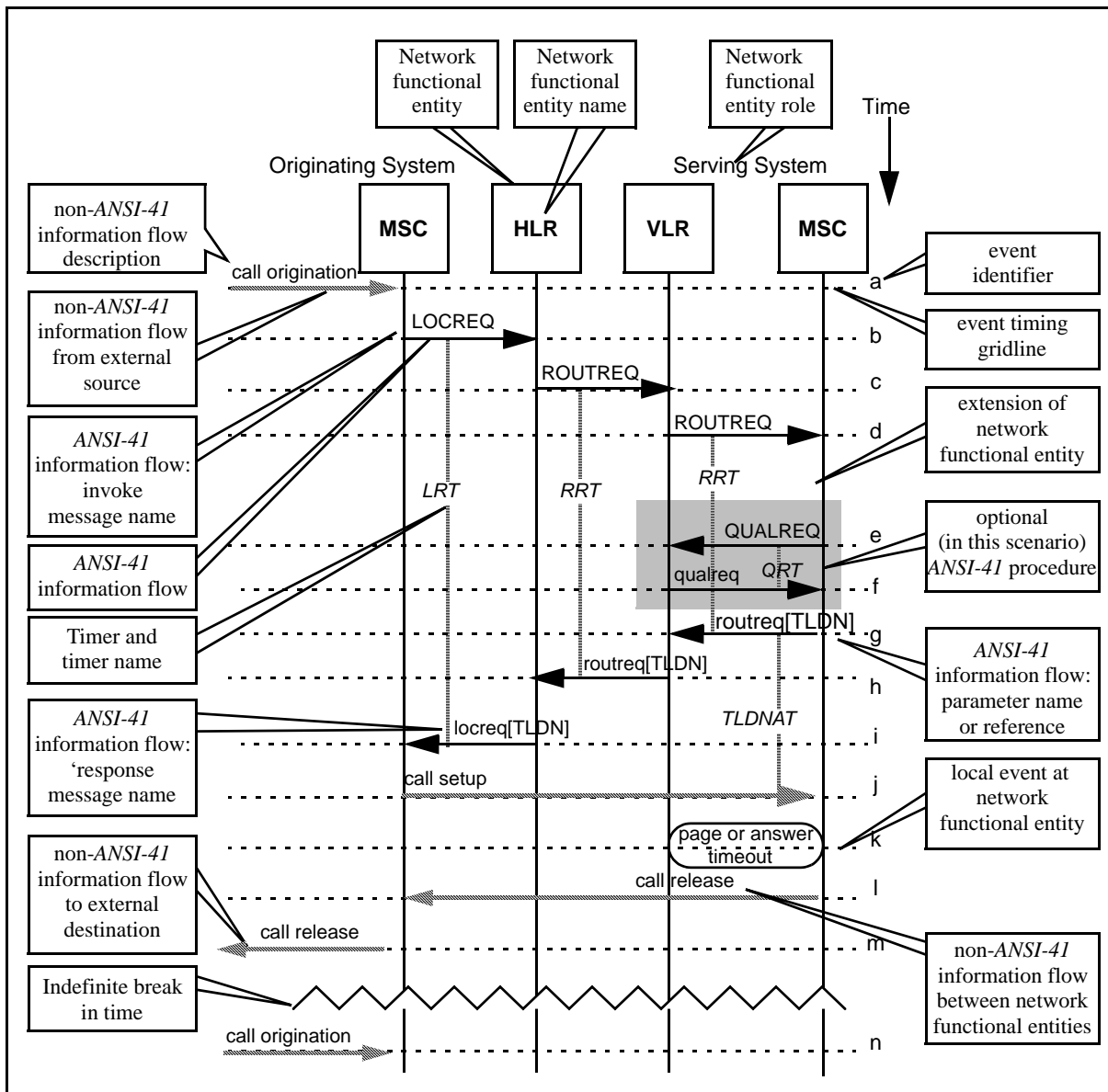

The following items should be noted in figure 1:

- i. Every event identifier must have an associated information flow.
- ii. Information flows are classified as either *TIA-41* or *non-TIA-41*; the former are subject to standardization in this document, while the latter are not.
- iii. Only functional entities which are involved in an information flow (i.e. source, destination, or tandem) are shown.
- iv. Use of parameter references, rather than the parameter names themselves, is permitted (e.g. TLDN rather than Digits (Destination)) where this is deemed to improve readability. However, the mapping of references to actual parameters must be provided.

- v. An *TIA-41* operation's INVOKE component is designated by an upper-case acronym (e.g. LOCREQ); its RETURN RESULT is designated by a lower-case acronym (e.g. locreq); its RETURN ERROR is designated by the full name (e.g. LocationRequest RETURN ERROR).
- vi. Optional *TIA-41* operations are enclosed by shaded areas. See events "e" and "f".

1
2
3
4
5
6
7
8
9
10
11
12
13
14
15
16
17
18
19
20
21
22
23
24
25
26
27
28
29
30
31
32
33
34
35
36
37
38
39
40
41
42
43
44
45
46
47
48
49
50
51
52
53
54
55
56
57
58
59
60

4.1.2 Scenario Description Conventions

The scenario descriptions presented in this document use the following conventions:

1. Each event identifier (or *step*) in a scenario diagram has an accompanying text description of the information flow involved.
2. Scenario steps which involve a *TIA-41* information flow are followed by a tabular listing of the parameters included in the operation component; e.g. :
 - c. The HLR determines that authorization can be granted to the MS and returns this indication to the Serving VLR in the `qualreq`.

Parameters	Usage	Type
AUTHPER	Authorization confirmed indication with period of authorization.	R
Profile:	Subscriber's profile information:	
[CFI]	Authorization and activity states for features.	R
[ORIGIND]	Type of calls MS is allowed to originate.	O
[TERMRES]	Type of calls MS is allowed to terminate.	O
HLRID [MSCID]	HLR MSCID to key MS record against for UnreliableRoamerDataDirective.	R
MYTYP	HLR vendor identification.	MBC

The following items from the table should be noted:

- When a more descriptive reference is used for one or more *TIA-41* parameters (e.g. HLRID vs. MSCID and Profile vs. the three *TIA-41* parameters listed), the *TIA-41* parameter(s), in square brackets, follows the reference. The reference is used in the scenario figure.
 - The Type refers to whether the parameter is Required (R) *for the scenario*, Optional (O) *for the scenario*, or Mandatory for Backward Compatibility (MBC). MBC identifies a parameter that is not used for the scenario but mandatory based on backward compatibility with previous versions of *TIA-41*.
3. Scenario steps which involve a *TIA-41* information flow are followed by a tabular listing of the *additional* parameters included in the operation component; e.g.:
 - c. The HLR detects the authorized CNIR request and sends a `featreq` to the Serving MSC. The `featreq` includes the OneTimeFeatureIndicator (OTFI).

Additional Parameters	Usage	Type
OTFI	Modify CNIR feature processing for the duration of this call originated by MS.	R

4. The following notation convention is used:
 - When referring to an operation, the operation name is used (e.g. AuthenticationDirective).

- When referring to the operation's INVOKE component, the uppercase acronym is used (e.g. AUTHDIR). 1
- When referring to the operation's RETURN RESULT component, the lowercase acronym is used (e.g. authdir). 2
- When referring to the operation's RETURN ERROR component, the full name of the operation is used (e.g. AuthenticationDirective RETURN ERROR). 3

4
5
6
7
8
9
10
11
12
13
14
15
16
17
18
19
20
21
22
23
24
25
26
27
28
29
30
31
32
33
34
35
36
37
38
39
40
41
42
43
44
45
46
47
48
49
50
51
52
53
54
55
56
57
58
59
60

4.1.3 TCAP Package Type Diagram Conventions

The following figure illustrates the diagrammatic conventions used to identify TCAP package types for the information exchange between network entities.

Figure 2 TCAP Package Type Diagram Conventions

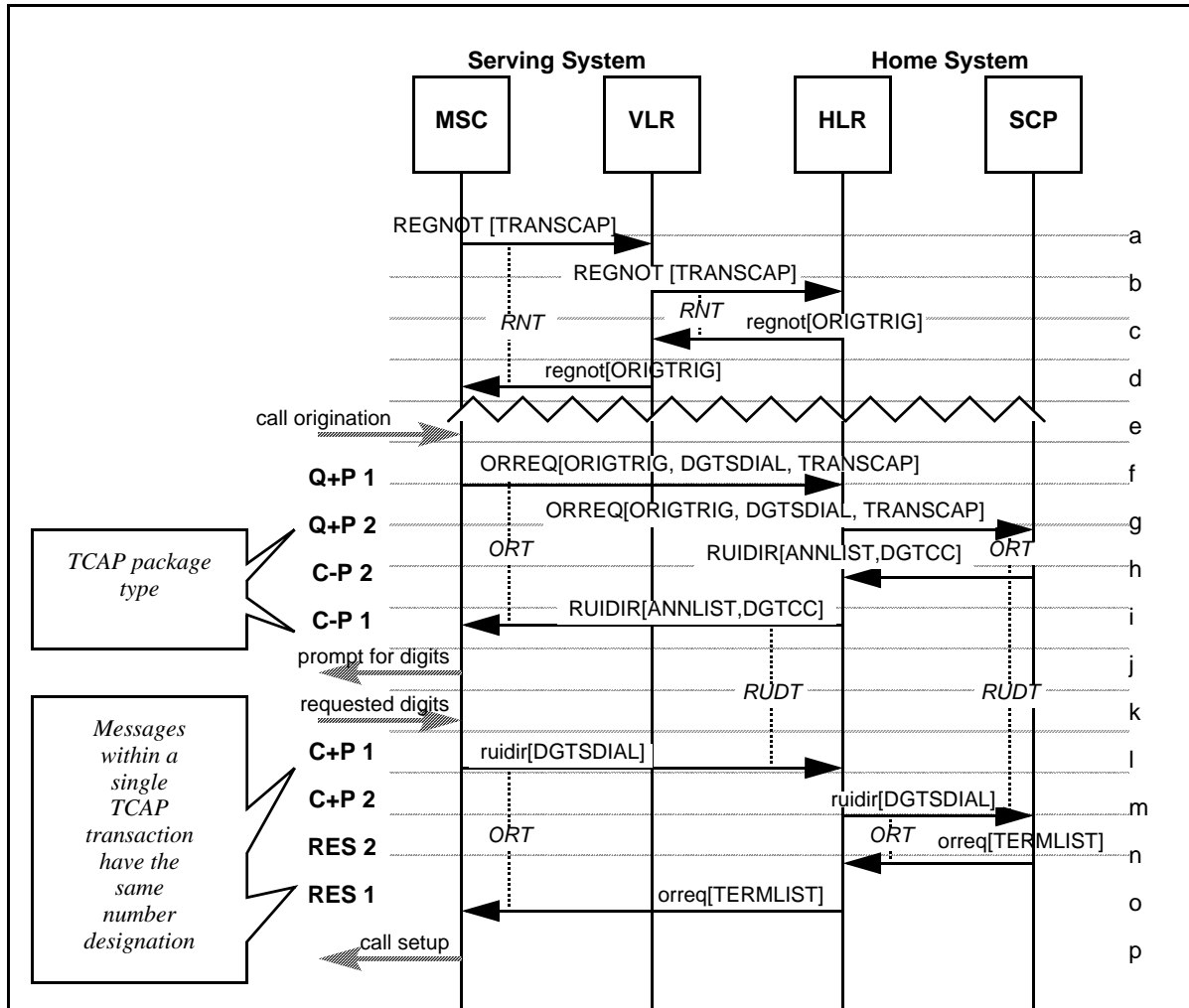

The following items should be noted:

- a. TCAP package types are only shown for complex TCAP transactions (i.e. more than two messages within the same TCAP transaction).
- b. The valid TCAP package types for complex TCAP transactions are:
 - Q+P Query with Permission
 - Q-P Query without Permission
 - C+P Conversation with Permission
 - C-P Conversation without Permission

- RES Response
- c. The number following the TCAP package type will be the same for all messages within a single TCAP transaction. By definition, a TCAP transaction involves only two network entities. The numbering begins at 1 in each figure and is incremented for each complex TCAP transaction.

1
2
3
4
5
6
7
8
9
10
11
12
13
14
15
16
17
18
19
20
21
22
23
24
25
26
27
28
29
30
31
32
33
34
35
36
37
38
39
40
41
42
43
44
45
46
47
48
49
50
51
52
53
54
55
56
57
58
59
60

5 NETWORK REFERENCE MODEL

The network reference model used by this standard is defined in *TSB100*.

5.1 NETWORK ENTITY RELATIONSHIP DIAGRAM

The following figures show the relationship between network entities identified in the Network Reference Model. The following symbols are used:

a. One-to-Many Relationship

This symbol indicates that entity “A” is associated with exactly one entity of type “B.” Each entity of type “B” is associated with one or more entities of type “A.”

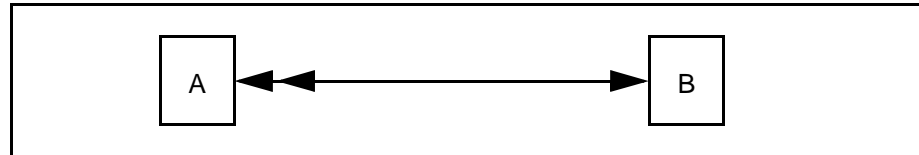

b. One-to-Zero or More Relationship

This symbol indicates that entity “A” is associated with exactly one entity of type “B.” Each entity of type “B” is associated with zero or more entities of type “A.”

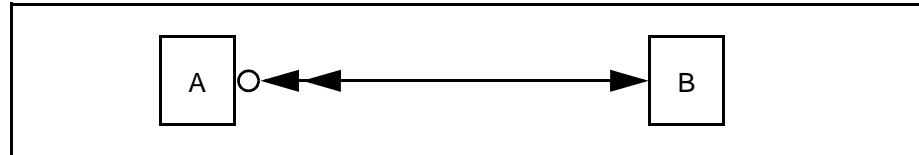

c. Many-to-Many Relationship

All pairs of entities for which a relationship is not shown have a many-to-many relationship (e.g. an HLR may have subscribers registered in many VLRs, and a VLR may be serving subscribers from many HLRs).

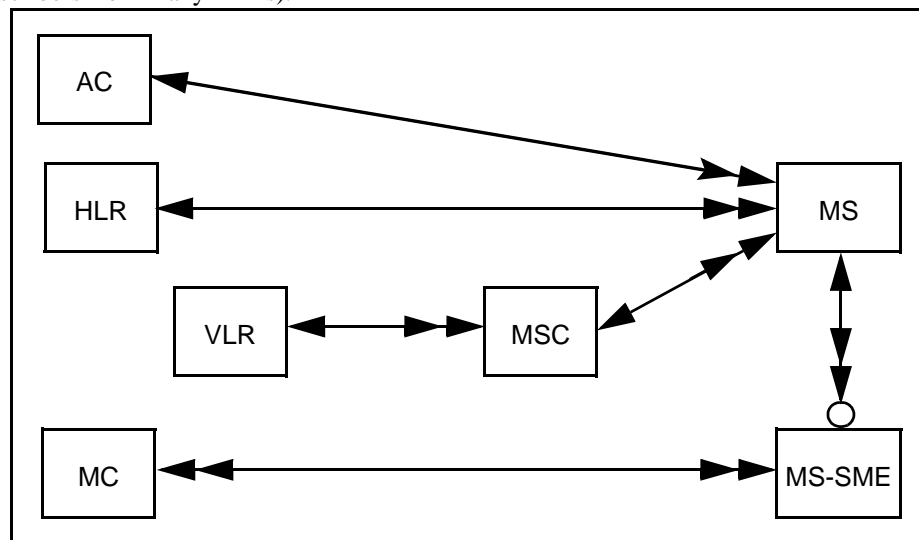

6 CELLULAR INTERSYSTEM SERVICES

This issue of the series addresses two major categories of intersystem services:

a. Intersystem Handoff

Intersystem Handoff refers to the general provisions by which a call in progress on a radio channel under the control of a current serving MSC may be automatically transferred to a different radio channel under the control of another MSC without interruption to the ongoing communication.

b. Automatic Roaming

Automatic Roaming refers to the general provisions for automatically providing cellular services to the MSs which are operating outside their home service area but within the aggregate service area of all participating MSCs. In the most general implementation these include:

1. Timely identification of the current serving MSC
2. Automatic Service Qualification of the roaming MSs, including credit validation, feature privileges, and feature control
3. Automatic call delivery to the roaming MSs.

The requirement that the procedures by which these operations are implemented be automatic is implicit in the intent of these recommendations.

1
2
3
4
5
6
7
8
9
10
11
12
13
14
15
16
17
18
19
20
21
22
23
24
25
26
27
28
29
30
31
32
33
34
35
36
37
38
39
40
41
42
43
44
45
46
47
48
49
50
51
52
53
54
55
56
57
58
59
60

6.1 GENERAL BACKGROUND AND ASSUMPTIONS

Procedures for the implementation of the identified intersystem services have been defined with due regard to the following general considerations:

- a. It is intended that the procedures defined afford, to each autonomous participant in any service (subscriber, service provider, etc.), control, to the maximum practical degree, over those aspects of operation which directly affect that participant.
- b. It is intended that the procedures defined address only the required intersystem transactions without infringing on the right of individual system operators and manufacturers to design their internal methods and procedures as they may deem best.
- c. All procedures are defined in terms of transactions conducted between the network entities defined in Section 5. This is not intended to preclude participation in the identified operations by entities such as "Clearinghouses," PSTN switching offices, etc.
- d. It is intended that the procedures defined provide the flexibility to utilize any suitable facilities commonly available to system operators for intersystem voice or data transmission and that any required facilities be utilized as efficiently as possible.
- e. It is intended that the procedures defined be usable in systems serving the small, non-urban areas as well as in the large metropolitan centers.
- f. An attempt has been made to conform to existing national or international standards.
- g. The procedures defined assume that the Cellular system equipment and the MS served operate according to the air-interface specifications referenced in Section 2. This does not mean that the procedures cannot operate correctly (or cannot be adapted to operate correctly) with other radio-telephone protocols, but that no particular effort has been made to ensure that they can.
- h. The procedures defined here are based on the assumption that intersystem handoff relies upon dedicated intersystem trunks. This is required since intersystem handoff is a tightly controlled activity of the cellular systems involved. Intersystem handoff cannot be considered any differently than an inter-cell handoff.
- i. Consideration has been given to the facilitation of valid routing under all appropriate conditions, whether mandated by regulatory authorities or not. This includes selection of the interexchange carrier.
- j. This Standard assumes support of the Intersystem Link Protocol [IS-728].
- k. For CDMA Systems, this Interim Standard provides intersystem support for Service Negotiation between the Serving BS/MS and MS.
- l. ASCII representations of calling party and redirecting party information have been defined within *TIA-41* for purposes of displaying this information to an MS. When this information is being manipulated within the network, the BCD representations shall be used.

6.2 OTA ASSUMPTIONS

- a. The OTASP feature is intended to meet a need of the wireless industry to enable and expedite in a secure manner the process by which potential wireless service subscribers can activate (i.e. become authorized for) new wireless service(s) or current subscribers can request changes in their existing service, without the intervention of a third party or parties.
- b. The OTAPA feature is initiated by the network service provider (and not by the mobile subscriber) to program Mobile Station Number Assignment Module (NAM) parameters and the CDMA Preferred Roaming list or the TDMA Intelligent Roaming Database (IRDB). These parameters control the wireless network usage by the MS. Administration of such parameters without the involvement of the mobile subscriber simplifies and significantly improves the customer care process by the network service providers.
- c. OTAPA does not require a voice dialogue with the service provider's customer service center and thus there is no need of involvement or interaction with the mobile subscriber during parameter administration. OTAPA can be performed at anytime while the MS is powered on and it does not interfere with normal end user operation (e.g. placing or receiving calls). If the mobile originates, receives, or ends a call while the OTAPA is in progress, the OTAPA is terminated. The interaction of OTAPA with SMS is controlled by the Air Interface specification. For CDMA, if an OTAPA override mechanism is provided, the default setting shall be "off" (meaning OTAPA is permitted by default).
- d. This recommendation assumes that MSs are compatible with the provisions in *TIA/EIA/136* for Over-the-Air Activation Teleservice (OATS) and *TIA/EIA-136-730* for Over-the-Air Programming Teleservice (OPTS), developed by TIA sub-committee TR-45.3 (TDMA), or with the provisions in *IS-683-A* Over-the-Air Service Provisioning of Mobile Stations in Spread Spectrum Systems, developed by TIA sub-committee TR-45.5 (CDMA).
- e. The MIN or IMSI or both stored in an HLR's record for an MS that is being reprogrammed by an OTASP or OTAPA shall not be changed until after all OTAF/AC interactions are completed.
- f. The OTAF shall not issue an order that would result in a newly assigned MSID being committed in either the MS or the AC until after all OTAF triggered SSD updates, if any, and MS Reauthentication procedures, if any, for the OTASP or OTAPA session have been completed.

6.3 NETWORK TMSI ASSUMPTIONS

These assumptions are related to the use of network TMSI (i.e. TMSI valid in more than one MSC).

- a. The IMSI associated with an MS's TMSI should be stored at the MSC for future paging of the MS. The MS should be paged with a valid TMSI (e.g. an invalid TMSI is one which is erroneously assigned to multiple MSs causing authentication to fail).
- b. The network supports full TMSI (i.e. TMSI-CODE and TMSI-ZONE) referred to as a NetworkTMSI. If the MS registers with a TMSI-CODE, the TMSI-ZONE is added to create a full TMSI (i.e. NetworkTMSI) before it is sent across the network.

6.4 WIRELESS INTELLIGENT NETWORK ASSUMPTIONS

- a. The Wireless Intelligent Network (WIN) is a network which supports the use of intelligent network capabilities to provide seamless terminal services, personal mobility services and advanced network services in the mobile environment.
- b. Intelligent network capabilities are all those functional capabilities which support creation and execution of service logic programs which reside outside of switching equipment, but work in collaboration with the switching equipment based upon a common definition of call models and protocols. These service logic programs may utilize data resources and physical resources which also reside outside of the switching equipment.
- c. Whenever new WIN triggers are identified for detection points (DPs) that have not had any previously defined triggers, new *TIA-41* operations have been defined to query WIN service logic from those DPs. This methodology provides for the smooth introduction of new capabilities while minimizing backwards compatibility issues that could arise from modifying the existing *TIA-41* operations. The name of the new *TIA-41* operation is the name of the DP where the new WIN trigger is defined. This methodology is consistent with the ITU-T methodology of naming operations based upon the DP associated with the operation.
- d. Interactions between WIN and both Flexible Alerting (FA) and Mobile Access Hunting (MAH) are beyond the scope of this document and therefore have not been modeled.

6.5 SEGMENTATION AND REASSEMBLY ASSUMPTIONS

- a. Signal Transfer points (STPs) within the signaling network that perform global title translation for messages that may be segmented must be upgraded to SCCP XUDT (with forward compatibility rules) capability (e.g. ANSI SCCP Issue 3) before the IS-812 solution approach may be utilized. Other STPs within the signaling network that do not perform global title translation for messages that may be segmented do not have to be upgraded to SCCP XUDT capability since the SCCP protocol layer is 'invisible' to these nodes.
- b. International signaling gateways that exist in the signaling path between source and destination network entities must be upgraded to SCCP S&R capability before the IS-812 solution approach may be utilized.

6.6 PCS MULTI-BAND SUPPORT ASSUMPTIONS

- a. This recommendation assumes existing *IS-41-C* or earlier 800 MHz Base Station equipment may not have the ability to perform signal strength measurements for an MS operating at the 1800 MHz band. If MAHO is not possible, 1800 MHz to 800 MHz interband handoffs with these existing *IS-41-C* or earlier systems may be “forced handoffs.”

6.7 IMSI SUPPORT ASSUMPTIONS

- a. Backward compatibility is handled in several different ways, depending on the circumstances of individual transactions:
- i. Mandatory MIN is replaced by mandatory MSID, when one of MIN or IMSI is required. This effectively changes MIN from a mandatory to an optional parameter.

A Serving, Border, or Anchor System sends IMSI towards an MS’s HLR if IMSI is received from the MS, unless the IMSI received is recognized as a MIN-based IMSI. An IMSI of the format MCC+10D shall be recognized as potential MIN-based IMSI. A potential MIN-based IMSI shall be recognized as a MIN-based IMSI if the MCC is one that has been designated by the associated country’s numbering authorities for this use. In the U.S., the MCC310 has been designated for use with MIN-based IMSIs. In addition, an IMSI of the form 000+00+10D should also be treated as a MIN-based IMSI.

If a Serving, Border, or Anchor System receives a MIN-based IMSI from an MS, it shall treat the 10D extracted from that IMSI as the MS’s MIN and include the MobileIdentificationNumber parameter in messages sent to the MS’s Home System HLR or in other messages in which that parameter should be included if the MIN is known.

- ii. Optional MIN is replaced by an optional MSID when one of MIN or IMSI (or neither) is possible.
- iii. Optional IMSI is added where both MIN and IMSI may be present (particularly in handoff messages and messages to an Originating MSC).
- b. The MSID is introduced as a documentation convenience. It is an ASN.1 CHOICE of MIN or IMSI. MSID has no physical encoding, as the *X.208* specification for ASN.1 specifies that the tag (parameter identification) of a type defined using the “CHOICE” keyword takes the value of the tag of the type from which the chosen data value is taken (i.e., MIN or IMSI).
- c. Registration with one identifier (MIN or IMSI) results in the alternate identifier being returned, if possible. This is to support call detail record generation, roamer port terminations, redirection, intersystem paging, local roaming between locations using IMSI and locations not using IMSI (e.g., a VLR supporting multiple MSCs), *TIA/EIA-136* authentication, etc.

An MSC contains a database that contains a record for each registered MS. The MSC’s record for a registered MS contains the MS identification information included by the MSC in the MSID parameter in the RegistrationNotification INVOKE sent to register the MS. If additional MS identification information was received in an MSID parameter in the RegistrationNotification RETURN RESULT, the additional MS identification information is also stored in the MSC’s record for the MS.

The VLR's record for a registered MS also stores this MS identification information.

- d. The VLR may substitute the MIN for the IMSI, or the IMSI for the MIN, in an INVOKE component received by the VLR, before forwarding the message to the MSC.

1
2
3
4
5
6
7
8
9
10
11
12
13
14
15
16
17
18
19
20
21
22
23
24
25
26
27
28
29
30
31
32
33
34
35
36
37
38
39
40
41
42
43
44
45
46
47
48
49
50
51
52
53
54
55
56
57
58
59
60

6.8 WIRELESS NUMBER PORTABILITY ASSUMPTIONS

- a. MobileDirectoryNumbers (MDNs) are the only wireless service provider's E.164 numbering resource that may be ported (e.g., Temporary Local Directory Numbers (TLDNs), Remote Feature Control (RFC) ports, Roamer Ports are not ported).
- b. This Number Portability document considers only "circuit mode calls."
- c. WNP interactions with Automatic Code Gapping (ACG) have not been addressed in this document.
- d. WNP interactions with Short Message Service (SMS) have not been addressed in this document.
- e. WNP interactions with other call-related features (e.g., Calling Name Presentation [CNAP]) have not been addressed in this document.
- f. WNP impacts on message accounting (e.g., *TIA/EIA-124* recommendations) have not been addressed in this document.
- g. WNP impacts to interface standards (e.g., *TIA/EIA-93*) have not been addressed in this document.
- h. Only limited location portability is supported consistent with *ANSI T1.660*. The designation of portable numbers may vary between systems. Establishing the geographical areas within which Number Portability (NP) must be supported is beyond the scope of this document.
- i. Number Portability databases (NPDBs) do not maintain records for numbers which are not ported.
- j. NP queries are performed by an MSC for all calls to numbers recognized as portable numbers, except for calls to portable numbers that are assumed to be not ported (see "a" above). NP queries are not performed for calls to operator services including calls dialed as "0+" calls.
- k. MobileStationIdentity (MSID) (i.e., InternationalMobileSubscriberIdentity [IMSI] or MobileIdentificationNumber [MIN]) is not portable.
- l. Public Switched Telephone Network (PSTN) directory numbers may be portable.
- m. The HLR operations (i.e., messages) have not been modified to support WNP. No new parameters, new parameter fields, or new parameter values have been added to existing HLR operations and no support is provided for HLR initiated Number Portability queries.
- n. An MSC which is Number Portability capable and has ISUP facilities supports *ANSI T1.660* on those facilities.
- o. Call looping should be avoided. However, no mechanism is provided by this standard to accomplish that objective.
- p. Roamer ports allow calls only to MSs known to be present in that system. NP queries are not performed for Roamer Port calls unless the called MS's HLR redirects the call from the MS to a portable number.
- q. ANSI ISUP Release Cause value 26 Misrouted call to ported number is supported to identify mismatches between the NPDB and HLR. Refinements to the use of Cause value 26 are for further study.
- r. An MSC knows which DN ranges are portable, but an MSC does not necessarily know

- 1 which individual MDNs have been ported.
- 2
- 3 s. When the MSC is not able to obtain portability information from the NPDB, the MSC shall
- 4 default route the call.
- 5
- 6 t. When a call is default routed to the donor MSC, and that MSC attempts to deliver the call,
- 7 the MSC performs a NumberPortabilityRequest (NPREQ) query to do so.
- 8
- 9 u. In a Number Portability environment the MobileIdentificationNumber (MIN) and
- 10 MobileDirectoryNumber (MDN) may be different.
- 11
- 12 v. Only the MDN shall be used by the Serving MSC in call services to identify the subscriber
- 13 externally (e.g. Emergency Services call back number, Automatic Number Identification).
- 14 The Serving MSC shall not, in the absence of a successful HLR response, make any
- 15 assumption as to the equivalence of an MDN and a MIN.
- 16
- 17 w. As this standard does not require the HLR to distinguish vacant numbers from numbers
- 18 which have ported out, implementation specific HLR operations (e.g., signaling
- 19 optimizations, forwarding number validation) may need to be modified so that service is
- 20 not impacted. The required modifications are not addressed in this document.
- 21
- 22 x. An NP capable MSC may support an ISUP trunk group option for signaling the ported
- 23 number instead of the LRN as the called party number for outgoing calls sent on that trunk
- 24 group.
- 25
- 26 y. WNP interactions with transit call handling (e.g., tandem calls) have not been addressed in
- 27 this document.
- 28
- 29 z. “Aging” and “Number Pooling” of MDNs have not been addressed in this document,
- 30 including their implications on the use of ANSI Cause value 26.
- 31
- 32

33 6.9 CALLING NAME PRESENTATION ASSUMPTIONS

- 35 a. This document describes intersystem operations for the implementation of Calling Name
- 36 Presentation (CNAP) and Calling Name Restriction (CNAR) services. Not all of the CNAP
- 37 and CNAR features and corresponding intersystem operations can be implemented in many
- 38 public networks because of regulatory constraints, limitations of interconnecting networks,
- 39 or other restrictions. Examples of such features include:
- 40
- 41 i. CNAR Blocking Toggle;
- 42
- 43 ii. the use of CNAR feature activation and deactivation codes that are distinct from
- 44 corresponding Calling Number Restriction (CNIR) feature activation or deactivation
- 45 code; and
- 46
- 47 iii. the use of distinct default presentation status for CNIR and CNAR.
- 48
- 49 b. There are circumstances in which a CNAP subscriber roaming in a CNAP capable system
- 50 receives an indication that a calling party name is *not available* for a call that is being
- 51 redirected to that subscriber, even though the calling party number has been received by the
- 52 subscriber’s Home System and the calling party name is available for retrieval from the
- 53 appropriate database (e.g., a Line Information Database). These circumstances are limited
- 54 to cases in which:
- 55
- 56 i. Before redirection, the call had been directed to an MS from the same Home System
- 57 as the Home System of the subscriber to which the call is being redirected.
- 58
- 59
- 60

- ii. The call is redirected by the Serving MSC, rather than by the Originating MSC.
- c. Similarly, in some cases in which these circumstances apply, if the subscriber to which the call is redirected is a CNIP subscriber, that subscriber may receive an indication that a calling party number is not available even though the calling party number has been received by the subscriber's Home System and the Serving System supports CNIP.
- d. These limitations have been accepted because the only proposal that addressed these limitations would have impacted call delivery for all calls, including calls to MSs that are not subscribed to CNAP (or CNIP), and because it is assumed that circumstances in which these limitations might interfere with the proper operation of CNAP (or CNIP) are rare.

6.10 AUTHENTICATION ENHANCEMENT ASSUMPTIONS

- a. The TR-45 Cellular Authentication and Voice Encryption algorithm (CAVE) shall be executed in an Authentication Center (AC), associated with the Home Location Register (HLR), or in the Visitor Location Center (VLR) if SSD is shared, and in the Mobile Station (MS). The HLR and MSC shall not be required to execute CAVE. As indicated below, the AC is a *functional* entity in the network reference model that may or may not be located within, and be distinguishable from, the HLR. (The interface between the AC and the HLR is for further study.)
- b. It is assumed that when the VLR receives a REGCANC it shall also cancel the subscriber's SSD and any pending operations immediately.
- c. It is assumed that the VLR shall not initiate a COUNT update for an unregistered MS.

7 RESTRICTIONS

- a. Voice facilities for intersystem handoff are restricted to direct dedicated circuits between pairs of participating systems.
- b. This version does not provide for flow control of data between applications. However, flow control is provided in the data link and network layer portions of this protocol.

1
2
3
4
5
6
7
8
9
10
11
12
13
14
15
16
17
18
19
20
21
22
23
24
25
26
27
28
29
30
31
32
33
34
35
36
37
38
39
40
41
42
43
44
45
46
47
48
49
50
51
52
53
54
55
56
57
58
59
60