



INCLUDES

- ✓ Course framework
- ✓ Instructional section
- ✓ Sample exam questions

AP[®] Physics 2: Algebra-Based

COURSE AND EXAM DESCRIPTION

Effective
Fall 2024



AP[®] Physics 2: Algebra-Based

COURSE AND EXAM DESCRIPTION

Effective
Fall 2024

AP COURSE AND EXAM DESCRIPTIONS ARE UPDATED PERIODICALLY

Please visit AP Central (apcentral.collegeboard.org) to determine whether a more recent course and exam description is available.

What AP[®] Stands For

Thousands of Advanced Placement teachers have contributed to the principles articulated here. These principles are not new; they are, rather, a reminder of how AP already works in classrooms nationwide. The following principles are designed to ensure that teachers' expertise is respected, required course content is understood, and that students are academically challenged and free to make up their own minds.

1. AP stands for clarity and transparency. Teachers and students deserve clear expectations. The Advanced Placement Program makes public its course frameworks and sample assessments. Confusion about what is permitted in the classroom disrupts teachers and students as they navigate demanding work.
2. AP is an unflinching encounter with evidence. AP courses enable students to develop as independent thinkers and to draw their own conclusions. Evidence and the scientific method are the starting place for conversations in AP courses.
3. AP opposes censorship. AP is animated by a deep respect for the intellectual freedom of teachers and students alike. If a school bans required topics from their AP courses, the AP Program removes the AP designation from that course and its inclusion in the AP Course Ledger provided to colleges and universities. For example, the concepts of evolution are at the heart of college biology, and a course that neglects such concepts does not pass muster as AP Biology.
4. AP opposes indoctrination. AP students are expected to analyze different perspectives from their own, and no points on an AP Exam are awarded for agreement with any specific viewpoint. AP students are not required to feel certain ways about themselves or the course content. AP courses instead develop students' abilities to assess the credibility of sources, draw conclusions, and make up their own minds.

As the AP English Literature course description states: "AP students are not expected or asked to subscribe to any one specific set of cultural or political values, but are expected to have the maturity to analyze perspectives different from their own and to question the meaning, purpose, or effect of such content within the literary work as a whole."

5. AP courses foster an open-minded approach to the histories and cultures of different peoples. The study of different nationalities, cultures, religions, races, and ethnicities is essential within a variety of academic disciplines. AP courses ground such studies in primary sources so that students can evaluate experiences and evidence for themselves.
6. Every AP student who engages with evidence is listened to and respected. Students are encouraged to evaluate arguments but not one another. AP classrooms respect diversity in backgrounds, experiences, and viewpoints. The perspectives and contributions of the full range of AP students are sought and considered. Respectful debate of ideas is cultivated and protected; personal attacks have no place in AP.
7. AP is a choice for parents and students. Parents and students freely choose to enroll in AP courses. Course descriptions are available online for parents and students to inform their choice. Parents do not define which college-level topics are suitable within AP courses; AP course and exam materials are crafted by committees of professors and other expert educators in each field. AP courses and exams are then further validated by the American Council on Education and studies that confirm the use of AP scores for college credits by thousands of colleges and universities nationwide.

The AP Program encourages educators to review these principles with parents and students so they know what to expect in an AP course. Advanced Placement is always a choice, and it should be an informed one. AP teachers should be given the confidence and clarity that once parents have enrolled their child in an AP course, they have agreed to a classroom experience that embodies these principles.

Contents

v Acknowledgments

1 About AP

4 AP Resources and Supports

5 Instructional Model

6 About the AP Physics 2 Course

6 College Course Equivalent

6 Prerequisites

6 Laboratory Requirement

COURSE FRAMEWORK

9 Introduction

10 Course Framework Components

11 Science Practices

13 Course Content

15 Course at a Glance

19 Unit Guides

21 Using the Unit Guides

23 **UNIT 9:** Thermodynamics

39 **UNIT 10:** Electric Force, Field, and Potential

57 **UNIT 11:** Electric Circuits

77 **UNIT 12:** Magnetism and Electromagnetism

91 **UNIT 13:** Geometric Optics

105 **UNIT 14:** Waves, Sound, and Physical Optics

131 **UNIT 15:** Modern Physics

LABORATORY INVESTIGATIONS

157 Lab Experiments

158 How to Set Up a Lab Program

160 Laboratory Investigations

INSTRUCTIONAL APPROACHES

167 Selecting and Using Course Materials

168 Guided Inquiry in AP Physics 2

171 Instructional Strategies

178 Developing the Science Practices

EXAM INFORMATION

189 Exam Overview

191 How Student Learning Is Assessed on the AP Exam

194 Task Verbs Used in Free-Response Questions

195 Sample Exam Questions

SCORING GUIDELINES

- 210 **Question 1: Mathematical Routines**
- 212 **Question 2: Translation Between Representations**
- 214 **Question 3: Experimental Design and Analysis**
- 216 **Question 4: Qualitative/Quantitative Translation**

APPENDIX

- 221 **Vocabulary and Definitions of Important Ideas in AP Physics**
- 227 **Table of Information: Equations**

Acknowledgments

College Board would like to acknowledge the following committee members, consultants, and reviewers for their assistance with and commitment to the development of this course. All individuals and their affiliations were current at the time of contribution.

Hamza Balci, *Kent State University, Kent, OH*
Suzanne Brahmia, *University of Washington, Seattle, WA*
Eric Burkholder, *Stanford University, Stanford, CA*
Whitney Coyle, *Rollins College, Winter Park, FL*
Robert Davis, *Brigham Young University, Provo, UT*
Veronica Ellingson, *Hudson Senior High School, Hudson, WI*
Kristin Glover, *Prairie Ridge High School, Crystal Lake, IL*
Kathy Harper, *Case Western Reserve University, Cleveland, OH*
Mark Hossler, *Landmark Christian School, Fairburn, GA*
Stefan Jeglinski, *University of North Carolina, Chapel Hill, NC*
David Kashinski, *United States Military Academy at West Point, West Point, NY*
Kathy Koenig, *University of Cincinnati, Cincinnati, OH*
Kristine Lang, *Colorado College, Colorado Springs, CO*
Samuel Lofland, *Rowan University, Glassboro, NJ*
Joe Mancino, *Glastonbury High School, Glastonbury, CT*
Ricardo Markland, *Miami Coral Park Senior High School, Miami, FL*
Dee Dee Messer, *William Mason High School, Mason, OH*
Holley Mosley, *Liberty High School, Frisco, TX*
Matt Sckalor, *Great Neck South High School, Great Neck, NY*
Peter Sheldon, *Randolph College, Lynchburg, VA*
Gay Stewart, *West Virginia University, Morgantown, WV*
Shelly Strand, *West Fargo High School, West Fargo, ND*
Oather Strawderman, *Lawrence Free State High School, Lawrence, KS*
Tiffany Taylor, *Rogers High School, Rogers, AR*
Brian Utter, *University of California Merced, Merced, CA*
Matt Vonk, *University of Wisconsin, River Falls, WI*

College Board Staff:

Amy Johnson, Director, AP Physics Curriculum and Assessment

Jesse Miner, Director, AP Physics Curriculum and Assessment

John Pinizzotto, Director, AP Physics Curriculum and Assessment

Shu-Kang Chen, Executive Director, AP STEM Curriculum and Assessment

Laura Keegan, Director, Product Development and Editorial,
AP Classroom Instruction

Claire Lorenz, Senior Director, AP Instruction

Serena Magrogan, Senior Director, AP Science Department Head

Daniel McDonough, Senior Director, AP Content and Assessment Publications

Allison Thurber, Vice President, AP Curriculum and Assessment

SPECIAL THANKS Brian Brown, Anders Gardestig, Ann Marie Zolanz,
Angela Jensvold, and Mark Widmer

About AP

The Advanced Placement® Program (AP®) enables willing and academically prepared students to pursue college-level studies—with the opportunity to earn college credit, advanced placement, or both—while still in high school. Through AP courses in 40 subjects, each culminating in a challenging exam, students learn to think critically, construct solid arguments, and see many sides of an issue—skills that prepare them for college and beyond. Taking AP courses demonstrates to college admission officers that students have sought the most challenging curriculum available to them, and research indicates that students who score a 3 or higher on an AP Exam typically experience greater academic success in college and are more likely to earn a college degree than non-AP students. Each AP teacher’s syllabus is evaluated and approved by faculty from some of the nation’s leading colleges and universities, and AP Exams are developed and scored by college faculty and experienced AP teachers. Most four-year colleges and universities in the United States grant credit, advanced placement, or both on the basis of successful AP Exam scores—more than 3,300 institutions worldwide annually receive AP scores.

AP Course Development

In an ongoing effort to maintain alignment with best practices in college-level learning, AP courses and exams emphasize challenging, research-based curricula aligned with higher education expectations.

Individual teachers are responsible for designing their own curriculum for AP courses, selecting appropriate college-level readings, assignments, and resources. This course and exam description presents the content and skills that are the focus of the corresponding college course and that appear on the AP Exam. It also organizes the content and skills into a series of units that represent a sequence found in widely adopted college textbooks and that many AP teachers have told us they follow in order to focus their instruction. The intention of this publication is to respect teachers’ time and expertise by providing a roadmap that they can modify and adapt to their local priorities and preferences. Moreover, by organizing the AP course content and skills into units, the AP Program is able to provide teachers and students with free formative

assessments—Progress Checks—that teachers can assign throughout the year to measure student progress as they acquire content knowledge and develop skills.

Enrolling Students: Equity and Access

The AP Program strongly encourages educators to make equitable access a guiding principle for their AP programs by giving all willing and academically prepared students the opportunity to participate in AP. We encourage the elimination of barriers that restrict access to AP for students from ethnic, racial, and socioeconomic groups that have been traditionally underserved. The AP Program also believes that all students should have access to academically challenging coursework before they enroll in AP classes, which can prepare them for AP success. It is only through a commitment to equitable preparation and access that true equity and excellence can be achieved.

Offering AP Courses: The AP Course Audit

The AP Program unequivocally supports the principle that each school implements its own curriculum that will enable students to develop the content understandings and skills described in the course framework.

While the unit sequence represented in this publication is optional, the AP Program does have a short list of curricular and resource requirements that must be fulfilled before a school can label a course “Advanced Placement” or “AP.” Schools wishing to offer AP courses must participate in the AP Course Audit, a process through which AP teachers’ course materials are reviewed by college faculty. The AP Course Audit was created to provide teachers and administrators with clear guidelines on curricular and resource requirements for AP courses and to help colleges and universities validate courses marked “AP” on students’ transcripts. This process ensures that AP teachers’ courses meet or exceed the curricular and resource expectations that college and secondary school faculty have established for college-level courses.

The AP Course Audit form is submitted by the AP teacher and the school principal (or designated administrator) to confirm awareness and understanding of the curricular and resource requirements. A syllabus or course outline, detailing how course requirements are met, is submitted by the AP teacher for review by college faculty.

Please visit collegeboard.org/apcourseaudit for more information to support the preparation and submission of materials for the AP Course Audit.

How the AP Program Is Developed

The scope of content for an AP course and exam is derived from an analysis of hundreds of syllabi and course offerings of colleges and universities. Using this research and data, a committee of college faculty and expert AP teachers work within the scope of the corresponding college course to articulate what students should know and be able to do upon the completion of the AP course. The resulting course framework is the heart of this course and exam description and serves as a blueprint of the content and skills that can appear on an AP Exam.

The AP Test Development Committees are responsible for developing each AP Exam, ensuring the exam questions are aligned to the course framework. The AP Exam development process is a multiyear endeavor; all AP Exams undergo extensive review, revision, piloting, and analysis to ensure that questions are accurate, fair, and valid, and that there is an appropriate spread of difficulty across the questions.

Committee members are selected to represent a variety of perspectives and institutions (public and private, small and large schools and colleges), and a range of gender, racial/ethnic, and regional groups. A list of each subject's current AP Test Development Committee members is available on apcentral.collegeboard.org.

Throughout AP course and exam development, College Board gathers feedback from various stakeholders in both secondary schools and higher education institutions. This feedback is carefully considered to ensure that AP courses and exams are able to provide students with a college-level learning experience and the opportunity to demonstrate their qualifications for advanced placement or college credit.

How AP Exams Are Scored

The exam scoring process, like the course and exam development process, relies on the expertise of both AP teachers and college faculty. While multiple-choice questions are scored by machine, the free-

response questions and through-course performance assessments, as applicable, are scored by thousands of college faculty and expert AP teachers. Most are scored at the annual AP Reading, while a small portion is scored online. All AP Readers are thoroughly trained, and their work is monitored throughout the Reading for fairness and consistency. In each subject, a highly respected college faculty member serves as Chief Faculty Consultant and, with the help of AP Readers in leadership positions, maintains the accuracy of the scoring standards. Scores on the free-response questions and performance assessments are weighted and combined with the results of the computer-scored multiple-choice questions, and this raw score is converted into a composite AP score on a 1–5 scale.

AP Exams are **not** norm-referenced or graded on a curve. Instead, they are criterion-referenced, which means that every student who meets the criteria for an AP score of 2, 3, 4, or 5 will receive that score, no matter how many students that is. The criteria for the number of points students must earn on the AP Exam to receive scores of 3, 4, or 5—the scores that research consistently validates for credit and placement purposes—include:

- The number of points successful college students earn when their professors administer AP Exam questions to them.
- Performance that researchers have found to be predictive of an AP student succeeding when placed into a subsequent higher-level college course.
- The number of points college faculty indicate, after reviewing each AP question, that they expect is necessary to achieve each AP grade level.

Using and Interpreting AP Scores

The extensive work done by college faculty and AP teachers in the development of the course and exam and throughout the scoring process ensures that AP Exam scores accurately represent students' achievement in the equivalent college course. Frequent and regular research studies establish the validity of AP scores as follows:

AP Score	Credit Recommendation	College Grade Equivalent
5	Extremely well qualified	A
4	Well qualified	A-, B+, B
3	Qualified	B-, C+, C
2	Possibly qualified	n/a
1	No recommendation	n/a

While colleges and universities are responsible for setting their own credit and placement policies, most private colleges and universities award credit and/or advanced placement for AP scores of 3 or higher. Additionally, most states in the U.S. have adopted statewide credit policies that ensure college credit for scores of 3 or higher at public colleges and universities. To confirm a specific college's AP credit/placement policy, a search engine is available at apstudent.collegeboard.org/creditandplacement/search-credit-policies.

BECOMING AN AP READER

Each June, thousands of AP teachers and college faculty members from around the world gather for seven days in multiple locations to evaluate and score the free-response sections of the AP Exams. Ninety-eight percent of surveyed educators who took part in the AP Reading say it was a positive experience.

There are many reasons to consider becoming an AP Reader, including opportunities to:

- **Bring positive changes to the classroom:** Surveys show that the vast majority of returning AP Readers—both high school and college

educators—make improvements to the way they teach or score because of their experience at the AP Reading.

- **Gain in-depth understanding of AP Exam and AP scoring standards:** AP Readers gain exposure to the quality and depth of the responses from the entire pool of AP Exam takers, and thus are better able to assess their students' work in the classroom.
- **Receive compensation:** AP Readers are compensated for their work during the Reading. Expenses, lodging, and meals are covered for Readers who travel.
- **Score from home:** AP Readers have online distributed scoring opportunities for certain subjects. Check collegeboard.org/apreading for details.
- **Earn Continuing Education Units (CEUs):** AP Readers earn professional development hours and CEUs that can be applied to PD requirements by states, districts, and schools.

How to Apply

Visit collegeboard.org/apreading for eligibility requirements and to start the application process.

AP Resources and Supports

By completing a simple class selection process at the start of the school year, teachers and students receive access to a robust set of classroom resources.

AP Classroom

AP Classroom is a dedicated online platform designed to support teachers and students throughout their AP experience. The platform provides a variety of powerful resources and tools to provide yearlong support to teachers and students, offering opportunities to give and get meaningful feedback on student progress.



UNIT GUIDES

Appearing in this publication and on AP Classroom, these planning guides outline all required course content and skills, organized into commonly taught units. Each Unit Guide suggests a sequence and pacing of content, scaffolds skill instruction across units, organizes content into topics, and provides tips on taking the AP Exam.



PROGRESS CHECKS

Formative AP questions for every unit provide feedback to students on the areas where they need to focus. Available online, Progress Checks measure knowledge and skills through multiple-choice questions with rationales to explain correct and incorrect answers, and free-response questions with scoring information. Because the Progress Checks are formative the results of these assessments cannot be used to evaluate teacher effectiveness or assign letter grades to students, and any such misuses are grounds for losing school authorization to offer AP courses.*



REPORTS

The Reports section provides teachers with a one-stop shop for student results on all assignment types, including Progress Checks. Teachers can view class trends and see where students struggle with content and skills that will be assessed on the AP Exam. Students can view their own progress over time to improve their performance before the AP Exam.



QUESTION BANK

The Question Bank is a searchable library of all AP questions that teachers use to build custom practice for their students. Teachers can create and assign assessments with formative topic questions or questions from practice or released AP Exams.

Class Section Setup and Enrollment

- Teachers and students sign in to or create their College Board accounts.
- Teachers confirm that they have added the course they teach to their AP Course Audit account and have had it approved by their school's administrator.
- Teachers or AP coordinators, depending on who the school has decided is responsible, set up class sections so students can access AP resources and have exams ordered on their behalf.
- Students join class sections with a join code provided by their teacher or AP coordinator.
- Students will be asked for additional information upon joining their first class section.

*To report misuses, please call, 877-274-6474 (International: 212-632-1781).

Instructional Model

Integrating AP resources throughout the course can help students develop skills and conceptual understandings. The instructional model outlined below shows possible ways to incorporate AP resources into the classroom.



Plan

Teachers may consider the following approaches as they plan their instruction before teaching each unit.

- Review the overview at the start of each **Unit Guide** to identify essential questions, conceptual understandings, and skills for each unit.
- Use the **Unit at a Glance** table to identify related topics that build toward a common understanding, and then plan appropriate pacing for students.
- Identify useful strategies in the **Instructional Approaches** section to help teach the concepts and skills.



Teach

When teaching, supporting resources could be used to build students' conceptual understanding and their mastery of skills.

- Use the topic pages in the **Unit Guides** to identify the required content.
- Integrate the content with a skill, considering any appropriate scaffolding.
- Employ any of the instructional strategies previously identified.
- Use the available resources, including **AP Daily**, on the topic pages to bring a variety of assets into the classroom.



Assess

Teachers can measure student understanding of the content and skills covered in the unit and provide actionable feedback to students.

- As you teach each topic, use **AP Classroom** to assign student **Topic Questions** as a way to continuously check student understanding and provide just in time feedback.
- At the end of each unit, use **AP Classroom** to assign students **Progress Checks**, as homework or an in-class task.
- Provide question-level feedback to students through answer rationales; provide unit- and skill-level formative feedback using **Reports**.
- Create additional practice opportunities using the **Question Bank** and assign them through **AP Classroom**.

About the AP Physics 2 Course

AP Physics 2 is an algebra-based, introductory college-level physics course. Students cultivate their understanding of physics by developing models of physical phenomena through inquiry-based investigations.

Students build their understanding of physical models as they explore and solve problems in these topics:

- Thermodynamics
- Electric Force, Field, and Potential
- Electric Circuits
- Magnetism and Electromagnetism
- Geometric Optics
- Waves, Sound, and Physical Optics
- Modern Physics

College Course Equivalent

AP Physics 2 is equivalent to the second course in an introductory college course sequence in algebra-based physics.

Prerequisites

Students should have completed AP Physics 1 or a comparable introductory physics course and should have taken or be concurrently taking pre-calculus or an equivalent course.

Laboratory Requirement

This course requires that 25 percent of instructional time be spent in hands-on laboratory work, with an emphasis on inquiry-based investigations that provide students with opportunities to demonstrate the foundational physics principles and apply the science practices.

Inquiry-based laboratory experiences support the AP Physics 2 course and AP Course Audit curricular requirements by providing opportunities for students to engage in the science practices as they design plans for experiments, make predictions, collect and analyze data, apply mathematical routines, develop explanations, and communicate about their work.

Colleges may require students to present their laboratory materials from AP science courses before granting college credit for laboratory work, so students should be encouraged to retain their laboratory notebooks, reports, and other materials.

AP PHYSICS 2

Course Framework



Introduction

The AP Physics 2 course outlined in this framework reflects a commitment to what physics teachers, professors, and researchers have agreed is the main goal of a college-level physics survey course: to help students develop a deep understanding of the foundational principles that shape classical mechanics and modern physics. By confronting complex physical situations or scenarios, the course is designed to enable students to develop the ability to reason about physical phenomena using important science practices, such as explaining relationships, applying and justifying the use of mathematical routines, designing experiments, analyzing data, and making connections across multiple topics within the course.

To foster this deeper level of learning, the AP Physics 2 course defines concepts, science practices, and understandings required by representative colleges and universities for granting college credit and placement. Students will practice reasoning skills used by physicists by discussing and debating, with peers, the physical phenomena investigated in class, as well as by designing and conducting inquiry-based laboratory investigations to solve problems through first-hand observations, data collection, analysis, and interpretation.

This document is not a complete curriculum. Teachers create their own local curriculum by selecting, for each concept, content that enables students to explore the course learning objectives and meets state or local requirements. The result is a course that prepares students for college credit and placement.

Course Framework Components

Overview

This course framework provides a clear and detailed description of the course requirements necessary for student success. The framework specifies what students must know, be able to do, and understand to qualify for college credit and/or placement.

The course framework includes two essential components:

1 SCIENCE PRACTICES

The science practices are central to the study and practice of physics. Students should develop and apply the described practices on a regular basis over the span of the course.

2 COURSE CONTENT

The course content is organized into commonly taught units of study that provide a suggested sequence for the course, and detail required content and conceptual understandings that colleges and universities typically expect students to be proficient in, in order to qualify for college credit and/or placement.

1

AP PHYSICS 2

Science Practices

The table that follows presents the science practices that students should develop during the AP Physics 2 course. These practices form the basis of many tasks on the AP Physics 2 Exam.

The Unit Guides that follow embed and spiral these practices throughout the course, providing teachers with one way to integrate the practices into the course content with sufficient repetition to prepare students to apply those science practices when taking the AP Physics 2 Exam.

More detailed information about teaching the science practices can be found in the [Instructional Approaches](#) section of this publication.



Practice 1

Creating Representations 1

Create representations that depict physical phenomena.

Practice 2

Mathematical Routines 2

Conduct analyses to derive, calculate, estimate, or predict.

Practice 3

Scientific Questioning and Argumentation 3

Describe experimental procedures, analyze data, and support claims.

SKILLS

1.A Create diagrams, tables, charts, or schematics to represent physical situations.

1.B Create quantitative graphs with appropriate scales and units, including plotting data.

1.C Create qualitative sketches of graphs that represent features of a model or the behavior of a physical system.

2.A Derive a symbolic expression from known quantities by selecting and following a logical mathematical pathway.

2.B Calculate or estimate an unknown quantity with units from known quantities, by selecting and following a logical computational pathway.

2.C Compare physical quantities between two or more scenarios or at different times and locations in a single scenario.

2.D Predict new values or factors of change of physical quantities using functional dependence between variables.

3.A Create experimental procedures that are appropriate for a given scientific question.

3.B Apply an appropriate law, definition, theoretical relationship, or model to make a claim.

3.C Justify or support a claim using evidence from experimental data, physical representations, or physical principles or laws.

2

AP PHYSICS 2

Course Content

The AP Physics 2 course framework provides a clear and detailed description of the course requirements for student success. The framework specifies what students must know, be able to do, and understand with a focus on ideas that encompass core principles, theories, and processes of physics. This framework also encourages instruction that prepares students to make connections across domains through a broader way of thinking about the physical world.

UNITS

The course content is organized into commonly taught units. The units have been arranged in a logical sequence frequently found in many college courses and textbooks.

The seven units in AP Physics 2 and their relevant weightings on the multiple-choice section of the AP Exam are listed on the next page.

Pacing recommendations on the Course at a Glance page provide suggestions for how teachers can cover both the required course content and the Progress Checks. The number of suggested class periods is based on a schedule in which the class meets five days a week for 45 minutes each day. While these recommendations have been made to aid in planning, teachers are free to adjust the pacing based on the needs of their students, alternate schedules (e.g., block scheduling), or their school's academic calendar.

Exam Weighting for the Multiple-Choice Section of the AP Physics 2 Exam.

Units of Instruction	Exam Weighting
<i>Unit 9: Thermodynamics</i>	15–18%
<i>Unit 10: Electric Force, Field, and Potential</i>	15–18%
<i>Unit 11: Electric Circuits</i>	15–18%
<i>Unit 12: Magnetism and Electromagnetism</i>	12–15%
<i>Unit 13: Geometric Optics</i>	12–15%
<i>Unit 14: Waves, Sound, and Physical Optics</i>	12–15%
<i>Unit 15: Modern Physics</i>	12–15%

TOPICS

Each unit is divided into teachable segments called topics. Visit the topic pages (starting on page 29) to see all the required content for each topic.

Learning Objectives and Science Practices

In the AP Physics 2 course and exam, every assessment of student proficiency will be aligned to a learning objective and a skill. The learning objectives represent the content domain, while the skill represents the science practice required to successfully complete the assessment. The three categories of science practices are described as discrete practices; they are in fact interrelated. For example, scientific questions and predictions are associated with underlying mathematical relationships, and those relationships are used to create diagrams and graphs. The ordering of the science practices is not meant to describe any hierarchy of importance or difficulty.

The three science practices, and their associated skills, will be applied to all learning objectives in the course framework. The task verb “describe,” which is used in nearly all learning objectives, encompasses the range of possible graphical, mathematical, or verbal skill applications. Within these multiple representations, students should be able to “describe” a physical concept graphically, mathematically, and verbally.

For example, for a given learning objective, teachers are encouraged to ask the following questions about a physical phenomenon:

- How would students create or interpret graphs or other visual representations?
- What quantitative problems could students solve?
- What experiment could a student design, or what data would students analyze?
- How could the concepts be described verbally?
- How could the material be used as evidence to justify or support a claim about the behavior of a system, physical phenomena, or outcome of an experiment?

Required Equations

Not all equations in this course framework appear on the equation sheet provided to students while taking the AP Physics 2 Exam. Many of the equations in this document are provided for reference and guidance, or to demonstrate the final results of derivations expected of students on the exam. These equations are denoted as “Derived Equations.” Additionally, variables used within this course framework follow the definitions given on the equation sheet. For a complete list of the equations available to students on the AP Physics 2 Exam, please see the AP Physics 2 Table of Information: Equations in the [Appendix](#).

Course at a Glance

Plan

The Course at a Glance provides a useful visual organization for the AP Physics 2 course components, including:

- Sequence of units, along with approximate weighting and suggested pacing. Please note, pacing is based on 45-minute class periods, meeting five days each week for a full academic year.
- Progression of topics within each unit.
- Spiraling of the science practices across units.

Teach

PRACTICES

Science Practices spiral throughout the course

- | | |
|-----------------------------------|---|
| 1 Creating Representations | 3 Scientific Questioning and Argumentation |
| 2 Mathematical Routines | |

Required Course Content

Each topic contains required Learning Objectives and Essential Knowledge Statements that form the basis of the assessment on the AP Exam.

Assess

Assign the Progress Checks—either as homework or in class—for each unit. Each Progress Check contains formative multiple-choice and free-response questions. The feedback from these checks shows students the areas where they need to focus.

UNIT 9 Thermodynamics

~10–16 Class Periods **15–18%** AP Exam Weighting

1
2
3 **9.1 Kinetic Theory of Temperature and Pressure**

1
2
3 **9.2 The Ideal Gas Law**

1
2
3 **9.3 Thermal Energy Transfer and Equilibrium**

1
2
3 **9.4 The First Law of Thermodynamics**

1
2
3 **9.5 Specific Heat and Thermal Conductivity**

1
2
3 **9.6 Entropy and the Second Law of Thermodynamics**

UNIT 10 Electric Force, Field, and Potential

~14–21 Class Periods **15–18%** AP Exam Weighting

1
2
3 **10.1 Electric Charge and Electric Force**

1
2
3 **10.2 Conservation of Electric Charge and the Process of Charging**

1
2
3 **10.3 Electric Fields**

1
2
3 **10.4 Electric Potential Energy**

1
2
3 **10.5 Electric Potential**

1
2
3 **10.6 Capacitors**

1
2
3 **10.7 Conservation of Electric Energy**

Progress Check 9

Multiple-choice: ~18 questions

Free-response: 4 questions

- Mathematical Routines
- Translation Between Representations
- Experimental Design and Analysis
- Qualitative/Quantitative Translation

Progress Check 10

Multiple-choice: ~24 questions

Free-response: 4 questions

- Mathematical Routines
- Translation Between Representations
- Experimental Design and Analysis
- Qualitative/Quantitative Translation

UNIT 11

Electric Circuits

~12–20

Class Periods

15–18%

AP Exam Weighting

1
2
3

11.1 Electric Current

1
2
3

11.2 Simple Circuits

1
2
3

11.3 Resistance, Resistivity, and Ohm's Law

1
2
3

11.4 Electric Power

1
2
3

11.5 Compound Direct Current (DC) Circuits

1
2
3

11.6 Kirchhoff's Loop Rule

1
2
3

11.7 Kirchhoff's Junction Rule

1
2
3

11.8 Resistor-Capacitor (RC) Circuits

UNIT 12

Magnetism and Electromagnetism

~10–13

Class Periods

12–15%

AP Exam Weighting

1
2
3

12.1 Magnetic Fields

1
2
3

12.2 Magnetism and Moving Charges

1
2
3

12.3 Magnetism and Current-Carrying Wires

1
2
3

12.4 Electromagnetic Induction and Faraday's Law

UNIT 13

Geometric Optics

~8–12

Class Periods

12–15%

AP Exam Weighting

1
2
3

13.1 Reflection

1
2
3

13.2 Images Formed by Mirrors

1
2
3

13.3 Refraction

1
2
3

13.4 Images Formed by Lenses

Progress Check 11

Multiple-choice: ~24 questions

Free-response: 4 questions

- Mathematical Routines
- Translation Between Representations
- Experimental Design and Analysis
- Qualitative/Quantitative Translation

Progress Check 12

Multiple-choice: ~18 questions

Free-response: 4 questions

- Mathematical Routines
- Translation Between Representations
- Experimental Design and Analysis
- Qualitative/Quantitative Translation

Progress Check 13

Multiple-choice: ~18 questions

Free-response: 4 questions

- Mathematical Routines
- Translation Between Representations
- Experimental Design and Analysis
- Qualitative/Quantitative Translation

UNIT 14

Waves, Sound, and Physical Optics

~14–23 Class Periods | **12–15%** AP Exam Weighting

- 1
2
3

14.1 Properties of Wave Pulses and Waves
- 1
2
3

14.2 Periodic Waves
- 1
2
3

14.3 Boundary Behavior of Waves and Polarization
- 1
2
3

14.4 Electromagnetic Waves
- 1
2
3

14.5 The Doppler Effect
- 1
2
3

14.6 Wave Interference and Standing Waves
- 1
2
3

14.7 Diffraction
- 1
2
3

14.8 Double-Slit Interference and Diffraction Gratings
- 1
2
3

14.9 Thin-Film Interference

UNIT 15

Modern Physics

~14–22 Class Periods | **12–15%** AP Exam Weighting

- 1
2
3

15.1 Quantum Theory and Wave-Particle Duality
- 1
2
3

15.2 The Bohr Model of Atomic Structure
- 1
2
3

15.3 Emission and Absorption Spectra
- 1
2
3

15.4 Blackbody Radiation
- 1
2
3

15.5 The Photoelectric Effect
- 1
2
3

15.6 Compton Scattering
- 1
2
3

15.7 Fission, Fusion, and Nuclear Decay
- 1
2
3

15.8 Types of Radioactive Decay

Progress Check 14

Multiple-choice: ~30 questions

Free-response: 4 questions

- Mathematical Routines
- Translation Between Representations
- Experimental Design and Analysis
- Qualitative/Quantitative Translation

Progress Check 15

Multiple-choice: ~24 questions

Free-response: 4 questions

- Mathematical Routines
- Translation Between Representations
- Experimental Design and Analysis
- Qualitative/Quantitative Translation

THIS PAGE IS INTENTIONALLY LEFT BLANK.

AP PHYSICS 2

Unit Guides

Introduction

Designed with input from the community of AP Physics 2 educators, the unit guides offer teachers helpful guidance in building students' skills and content knowledge. The suggested sequence was identified through a thorough analysis of the syllabi of highly effective AP teachers and the organization of typical college textbooks.

This unit structure respects new AP teachers' time by providing one possible sequence that can adopt or modify rather than having to build from scratch. An additional benefit is that these units enable the AP Program to provide interested teachers with formative assessments—the Progress Checks—that they can assign their students at the end of each unit to gauge progress toward success on the AP Exam. However, experienced AP teachers who are satisfied with their current course organization and exam results should feel no pressure to adopt these units, which comprise an optional sequence for this course.

THIS PAGE IS INTENTIONALLY LEFT BLANK.

Using the Unit Guides

UNIT 9
15–18% AP EXAM WEIGHTING
~10–16 CLASS PERIODS

Thermodynamics

ESSENTIAL QUESTIONS

- Why does the tile floor in the bathroom feel so much colder than the bathroom mat?
- How cold can something get?
- How would our lives be different without heat engines?
- How do the laws of thermodynamics help us understand the limitations in function and efficiency of technological systems?

Developing Understanding

In Unit 9, students investigate what they cannot see by examining the properties of ideal gases. This unit's focus is the study of relationships and change, so it is important that students can discuss—and describe mathematically—what happens when a physical scenario changes, such as the consequences of heating or cooling a system. Students will use the first law of thermodynamics and PV diagrams to represent and analyze thermodynamic processes. Thermal energy transfer and material properties such as specific heat and thermal conductivity will be studied. Unit 9 also acquaints students with the second law of thermodynamics, including entropy.

Building the Science Practices

Translation between models and representations is key in this unit. Students will continue to use models and representations that will help them further analyze systems, the interactions between systems, and how these interactions result in change. Alongside gaining proficiency in the use of specific thermodynamic equations, Unit 9 also encourages students to derive expressions from fundamental principles (2.A) to help them make predictions using functional dependence between variables (2.D). The skills of making claims (3.B), and supporting those claims using evidence (3.C), can be developed through the unit by providing students with opportunities to make predictions about the temperature of an ideal gas in a sealed container, based on the changes in volume and the heat added to or removed from the gas, and then justifying those predictions with appropriate physics principles.

Preparing for the AP Exam

The AP Physics 2 Exam requires students to re-express key elements of physical phenomena across multiple representations in the domain. This skill appears in the second question of the free-response section, the Qualitative/Quantitative Translation (QQT). In this question, students demonstrate translation between words and mathematics by describing and analyzing a scenario. Using content from any unit, the QQT first requires students to make a claim and provide evidence and reasoning to support their claim without reference to equations. Students are then asked to derive an equation or set of equations to mathematically represent the scenario. Lastly, students are required to make a connection between the claim made in the first part of the question and the equation(s) derived in the second part. Students exposed primarily to numerical problem solving often struggle with the QQT because it requires them to express a conceptual understanding of course content and representations. Opportunities to translate between different representations, including equations, diagrams, graphs, and verbal descriptions, can help students prepare for the QQT question.

AP Physics 2: Algebra-Based Course and Exam Description
Course Framework V.1 | 25

UNIT OPENERS

Developing Understanding provides an overview that contextualizes and situates the key content of the unit within the scope of the course.

The **essential questions** are thought-provoking questions that motivate students and inspire inquiry.

Building the Science Practices describes skills within the practices that are appropriate to focus on in that unit. Certain practices have been noted to indicate areas of emphasis for that unit.

Preparing for the AP Exam provides helpful tips and common student misunderstandings identified from prior exam data.

UNIT 13
Geometric Optics

UNIT AT A GLANCE

Topic	Suggested Skills
13.1 Reflection	<ul style="list-style-type: none"> 1.A Create diagrams, tables, charts, or schematics to represent physical situations. 1.B Calculate or estimate an unknown quantity with units from known quantities, by selecting and following a logical computational pathway. 1.C Compare physical quantities between two or more scenarios or at different times and locations in a single scenario. 1.D Apply an appropriate law, definition, theoretical relationship, or model to make a claim.
13.2 Images Formed by Mirrors	<ul style="list-style-type: none"> 1.A Create diagrams, tables, charts, or schematics to represent physical situations. 1.B Derive a symbolic expression from known quantities by selecting and following a logical mathematical pathway. 1.C Compare physical quantities between two or more scenarios or at different times and locations in a single scenario. 1.D Justify or support a claim using evidence from experimental data, physical representations, or physical principles or laws.
13.3 Refraction	<ul style="list-style-type: none"> 1.A Create quantitative graphs with appropriate scales and units, including plotting data. 1.B Calculate or estimate an unknown quantity with units from known quantities, by selecting and following a logical computational pathway. 1.C Predict new values or factors of change of physical quantities using functional dependence between variables. 1.D Create experimental procedures that are appropriate for a given scientific question. 1.E Apply an appropriate law, definition, theoretical relationship, or model to make a claim.
13.4 Images Formed by Lenses	<ul style="list-style-type: none"> 1.A Create qualitative sketches of graphs that represent features of a model or the behavior of a physical system. 1.B Calculate or estimate an unknown quantity with units from known quantities, by selecting and following a logical computational pathway. 1.C Predict new values or factors of change of physical quantities using functional dependence between variables. 1.D Create experimental procedures that are appropriate for a given scientific question. 1.E Apply an appropriate law, definition, theoretical relationship, or model to make a claim.

Go to [AP Classroom](#) to assign the **Progress Check** for Unit 13. Review the results in class to identify and address any student misunderstandings.

94 | Course Framework V.1
AP Physics 2: Algebra-Based Course and Exam Description

The **Unit at a Glance** table shows the topics, and suggested skills.

The **suggested skills** for each topic show possible ways to link the content in that topic to specific AP Physics skills. The individual skills have been thoughtfully chosen in a way that scaffolds the skills throughout the course. The questions on the Progress Checks are based on this pairing. However, AP Exam questions can pair the content with any of the skills.

SAMPLE INSTRUCTIONAL ACTIVITIES

The sample activities on this page are optional and are offered to provide possible ways to incorporate instructional approaches into the classroom. Teachers do not need to use these activities or instructional approaches and are free to alter or edit them. The examples below were developed in partnership with teachers from the AP community to share ways that they approach teaching some of the topics in this unit. Please refer to the Instructional Approaches section beginning on p. 163 for more examples of activities and strategies.

Activity	Topic	Sample Activity
1	9.2	Desktop Experiment Tasks Break students into groups of 3-4. Give each group a 10 mL syringe with a Luer-Lok tip and a Luer-Lok cap. Instruct students to set the syringe to 10 mL, cap the end, turn the syringe vertical, and stack books on top. Have students then calculate the absolute pressure of the books plus atmosphere and make a pressure versus volume graph.
2	9.2	Changing Representations Show students a single thermodynamic process on a PVP/DVT diagram and a molecular-velocity distribution graph for the "initial" state. Have students draw the distribution for the "final" state or explain why it is the same graph (if it is).
3	9.4	Discussion Groups Break class into groups of 3-4 students. Each group is to come up with a way to demonstrate each of the eight thermodynamic processes (isobaric, isochoric, isothermal, and adiabatic, each in both possible directions) using cheap-to-obtain/common school or household items. Example: for adiabatic compression, cap a syringe and push on the plunger really hard (see "the syringe" for more on this example).
4	9.4	Graph and Switch Break students into groups of 4. Have student A describe a three-step cyclical thermodynamic process (e.g., "isochoric heating, isothermal expansion, isobaric cooling") then have students B, C, and D make a P-V, P-T, and V-T diagram (respectively) of the cycle.
5	9.4	Construct an Argument/Concept-Oriented Demonstration Look up a photo of a "Cortijo Autospout Addison Water Bottle" and show it to students. Explain that a person takes this partially filled water bottle up to the top of a mountain, opens it, and gets sprayed in the face with water. Ask students to explain why and whether more water would spray out if there is more or less water in the bottle (answer: less). Ask students to discuss what would happen if the bottle is taken out of the refrigerator, opened, and the person gets sprayed.

The **Sample Instructional Activities** page includes optional activities that can help teachers tie together the content and skill for a particular topic.

TOPIC 14.5 The Doppler Effect

- SUGGESTED SKILLS**
- 1.A** Create diagrams, tables, charts, or schematics to represent physical situations.
 - 1.B** Compare physical quantities between two or more scenarios or at different times and locations in a single scenario.
 - 2.A** Apply an appropriate law, definition, theoretical relationship, or model to make a claim.
 - 2.B** Justify or support a claim using evidence from experimental data, physical representations, or physical principles or laws.

Required Course Content

LEARNING OBJECTIVE

14.A.A
Describe the properties of a wave based on the relative motion between the source of the wave and the observer of the wave.

ESSENTIAL KNOWLEDGE

- 14.A.A.1**
The Doppler effect describes the relationship between the rest frequency of a wave source, the observed frequency of the source, and the relative velocity of the source and the observer.
- 14.A.A.2**
A greater relative velocity results in a greater measured difference between the observed and rest frequencies.
 - 14.A.A.2.1**
For a wave source moving at the same velocity as the observer, the observed frequency is equal to the rest frequency.
 - 14.A.A.2.2**
For a wave source moving toward an observer, the observed frequency is greater than the rest frequency.
 - 14.A.A.2.3**
For a wave source moving away from an observer, the observed frequency is less than the rest frequency.

BOUNDARY STATEMENT:
Only qualitative treatments of the Doppler effect are required for AP Physics 2.

TOPIC PAGES

The **suggested skill** offers a possible skill to pair with the topic.

Learning objectives statements define what a student needs to be able to do with content knowledge in order to progress through the course.

Essential knowledge statements define the required content knowledge associated with each learning objective assessed on the AP Exam.

Boundary statements provide guidance to teachers regarding the content boundaries of the AP Physics courses. Boundary statements appear at the end of essential knowledge statements where appropriate.

AP PHYSICS 2

UNIT 9

Thermodynamics



15–18%
AP EXAM WEIGHTING



~10–16
CLASS PERIODS

The icon consists of a white circle containing a blue square with the letters 'AP' in white. Below the square is a blue horizontal line with a small vertical tick mark in the center, resembling a computer monitor or a document icon.

Remember to go to [AP Classroom](#) to assign students the online **Progress Check** for this unit.

Whether assigned as homework or completed in class, the **Progress Check** provides each student with immediate feedback related to this unit's topics and science practices.

Progress Check 9

Multiple-choice: ~18 questions

Free-response: 4 questions

- Mathematical Routines
- Translation Between Representations
- Experimental Design and Analysis
- Qualitative/Quantitative Translation

Thermodynamics



Developing Understanding

ESSENTIAL QUESTIONS

- Why does the tile floor in the bathroom feel so much colder than the bathroom mat?
- How cold can something get?
- How would our lives be different without heat engines?
- How do the laws of thermodynamics help us understand the limitations in function and efficiency of technological systems?

In Unit 9, students investigate what they cannot see by examining the properties of ideal gases. This unit's focus is the study of relationships and change, so it is important that students can discuss—and describe mathematically—what happens when a physical scenario changes, such as the consequences of heating or cooling a system. Students will use the first law of thermodynamics and PV diagrams to represent and analyze thermodynamic processes. Thermal energy transfer and material properties such as specific heat and thermal conductivity will be studied. Unit 9 also acquaints students with the second law of thermodynamics, including entropy.

Building the Science Practices

2.A 2.D 3.B 3.C

Translation between models and representations is key in this unit. Students will continue to use models and representations that will help them further analyze systems, the interactions between systems, and how these interactions result in change. Alongside gaining proficiency in the use of specific thermodynamic equations, Unit 9 also encourages students to derive expressions from fundamental principles (2.A) to help them make predictions using functional dependence between variables (2.D). The skills of making claims (3.B), and supporting those claims using evidence (3.C), can be developed through the unit by providing students with opportunities to make predictions about the temperature of an ideal gas in a sealed container, based on the changes in volume and the heat added to or removed from the gas, and then justifying those predictions with appropriate physics principles.

Preparing for the AP Exam

The AP Physics 2 Exam requires students to re-express key elements of physical phenomena across multiple representations in the domain. This skill appears in the fourth question of the free-response section, the Qualitative/Quantitative Translation (QQT). In this question, students demonstrate translation between words and mathematics by describing and analyzing a scenario. Using content from any unit, the QQT first requires students to make a claim and provide evidence and reasoning to support their claim without reference to equations. Students are then asked to derive an equation or set of equations to mathematically represent the scenario. Lastly, students are required to make a connection between the claim made in the first part of the question and the equation(s) derived in the second part. Students exposed primarily to numerical problem solving often struggle with the QQT because it requires them to express a conceptual understanding of course content and representations. Opportunities to translate between different representations, including equations, diagrams, graphs, and verbal descriptions, can help students prepare for the QQT question.

UNIT AT A GLANCE

Topic	Suggested Skills
9.1 Kinetic Theory of Temperature and Pressure	<p>1.A Create diagrams, tables, charts, or schematics to represent physical situations.</p> <p>2.C Compare physical quantities between two or more scenarios or at different times and locations in a single scenario.</p> <p>3.B Apply an appropriate law, definition, theoretical relationship, or model to make a claim.</p> <p>3.C Justify or support a claim using evidence from experimental data, physical representations, or physical principles or laws.</p>
9.2 The Ideal Gas Law	<p>1.B Create quantitative graphs with appropriate scales and units, including plotting data.</p> <p>2.C Compare physical quantities between two or more scenarios or at different times and locations in a single scenario.</p> <p>2.D Predict new values or factors of change of physical quantities using functional dependence between variables.</p> <p>3.A Create experimental procedures that are appropriate for a given scientific question.</p> <p>3.B Apply an appropriate law, definition, theoretical relationship, or model to make a claim.</p>
9.3 Thermal Energy Transfer and Equilibrium	<p>1.A Create diagrams, tables, charts, or schematics to represent physical situations.</p> <p>2.C Compare physical quantities between two or more scenarios or at different times and locations in a single scenario.</p> <p>3.B Apply an appropriate law, definition, theoretical relationship, or model to make a claim.</p> <p>3.C Justify or support a claim using evidence from experimental data, physical representations, or physical principles or laws.</p>
9.4 The First Law of Thermodynamics	<p>1.C Create qualitative sketches of graphs that represent features of a model or the behavior of a physical system.</p> <p>2.A Derive a symbolic expression from known quantities by selecting and following a logical mathematical pathway.</p> <p>2.C Compare physical quantities between two or more scenarios or at different times and locations in a single scenario.</p> <p>3.C Justify or support a claim using evidence from experimental data, physical representations, or physical principles or laws.</p>

continued on next page

UNIT AT A GLANCE *(cont'd)*

Topic	Suggested Skills
9.5 Specific Heat and Thermal Conductivity	<ul style="list-style-type: none">1.B Create quantitative graphs with appropriate scales and units, including plotting data.2.B Calculate or estimate an unknown quantity with units from known quantities, by selecting and following a logical computational pathway.2.D Predict new values or factors of change of physical quantities using functional dependence between variables.3.A Create experimental procedures that are appropriate for a given scientific question.3.B Apply an appropriate law, definition, theoretical relationship, or model to make a claim.
9.6 Entropy and the Second Law of Thermodynamics	<ul style="list-style-type: none">1.A Create diagrams, tables, charts, or schematics to represent physical situations.2.C Compare physical quantities between two or more scenarios or at different times and locations in a single scenario.3.B Apply an appropriate law, definition, theoretical relationship, or model to make a claim.3.C Justify or support a claim using evidence from experimental data, physical representations, or physical principles or laws.

 Go to **AP Classroom** to assign the **Progress Check** for Unit 9.
Review the results in class to identify and address any student misunderstandings.

SAMPLE INSTRUCTIONAL ACTIVITIES

The sample activities on this page are optional and are offered to provide possible ways to incorporate instructional approaches into the classroom. Teachers do not need to use these activities or instructional approaches and are free to alter or edit them. The examples below were developed in partnership with teachers from the AP community to share ways that they approach teaching some of the topics in this unit. Please refer to the Instructional Approaches section beginning on p. 167 for more examples of activities and strategies.

Activity	Topic	Sample Activity
1	9.2	Desktop Experiment Tasks Break students into groups of 3-4. Give each group a 10 mL syringe with a Luer-Lok tip and a Luer-Lok cap. Instruct students to set the syringe to 10 mL, cap the end, turn the syringe vertical, and stack books on top. Have students then calculate the absolute pressure of the books plus atmosphere and make a pressure versus volume graph.
2	9.2	Changing Representations Show students a single thermodynamic process on a PV/PT/VT diagram and an atomic-speed distribution graph for the "initial" state. Have students draw the distribution for the "final" state or explain why it is the same graph (if it is).
3	9.4	Discussion Groups Break class into groups of 3-4 students. Each group is to come up with a way to demonstrate each of the eight thermodynamic processes (isobaric, isovolumetric, isothermal, and adiabatic, each in both possible directions) using cheap-to-obtain/common school or household items. Example: for adiabatic compression, cap a syringe and push on the plunger really hard (see "fire syringe" for more on this example).
4	9.4	Graph and Switch Break students into groups of 4. Have student A describe a three-step cyclical thermodynamic process (e.g., "isochoric heating, isothermal expansion, isobaric cooling") then have students B, C, and D make a PV, PT, and VT diagram (respectively) of the cycle.
5	9.4	Construct an Argument/Concept-Oriented Demonstration Look up a photo of a "Contigo Autospout Addison Water Bottle" and show it to students. Explain that a person takes this partially filled water bottle up to the top of a mountain, opens it, and gets sprayed in the face with water. Ask students to explain why and whether more water would spray out if there is more or less water in the bottle (answer: less). Ask students to discuss what would happen if the bottle is taken out of a refrigerator, opened, and the person gets sprayed.

TOPIC 9.1

Kinetic Theory of Temperature and Pressure

Required Course Content

LEARNING OBJECTIVE

9.1.A

Describe the pressure a gas exerts on its container in terms of atomic motion within that gas.

9.1.B

Describe the temperature of a system in terms of the atomic motion within that system.

ESSENTIAL KNOWLEDGE

9.1.A.1

Atoms in a gas collide with and exert forces on other atoms in the gas and with the container in which the gas is contained.

9.1.A.1.i

Collisions involving pairs of atoms or an atom and a fixed object, can be described and analyzed using conservation of momentum principles.

9.1.A.1.ii

The pressure exerted by a gas on a surface is the ratio of the sum of the magnitudes of the perpendicular components of the forces exerted by the gas's atoms on the surface to the area of the surface.

Relevant equation:

$$P = \frac{F_{\perp}}{A}$$

9.1.A.1.iii

Pressure exists throughout the gas itself, not just at the boundary between the gas and the container.

9.1.B.1

The temperature of a system is characterized by the average kinetic energy of the atoms within that system.

9.1.B.1.i

The Maxwell–Boltzmann distribution provides a graphical representation of the energies and speeds of atoms at a given temperature.

SUGGESTED SKILLS

1.A

Create diagrams, tables, charts, or schematics to represent physical situations.

2.C

Compare physical quantities between two or more scenarios or at different times and locations in a single scenario.

3.B

Apply an appropriate law, definition, theoretical relationship, or model to make a claim.

3.C

Justify or support a claim using evidence from experimental data, physical representations, or physical principles or laws.

continued on next page

LEARNING OBJECTIVE**9.1.B**

Describe the temperature of a system in terms of the atomic motion within that system.

ESSENTIAL KNOWLEDGE**9.1.B.1.ii**

The root-mean-square speed corresponding to the average kinetic energy for an ideal gas is related to the temperature of the gas by

$$K_{\text{avg}} = \frac{3}{2}k_bT = \frac{1}{2}mv_{\text{rms}}^2$$

BOUNDARY STATEMENT

AP Physics 2 only expects students to perform qualitative and quantitative analysis of collisions in one and two dimensions. Students are not expected to know the functional form of the Maxwell-Boltzmann distribution but are expected to be familiar with how features of the distribution are related to the temperature of the gas.

TOPIC 9.2

The Ideal Gas Law

Required Course Content

LEARNING OBJECTIVE

9.2.A

Describe the properties of an ideal gas.

ESSENTIAL KNOWLEDGE

9.2.A.1

The classical model of an ideal gas assumes that the instantaneous velocities of atoms are random, the volumes of the atoms are negligible compared to the total volume occupied by the gas, the atoms collide elastically, and the only appreciable forces on the atoms are those that occur during collisions.

9.2.A.2

An ideal gas is one in which the relationships between pressure, volume, the number of moles or number of atoms, and temperature of a gas can be modeled using the equation

$$PV = nRT = Nk_bT.$$

9.2.A.3

Graphs modeling the pressure, temperature, and volume of gases can be used to describe or determine properties of that gas.

9.2.A.4

A temperature at which an ideal gas has zero pressure can be extrapolated from a graph of pressure as a function of temperature.

SUGGESTED SKILLS

1.A

Create diagrams, tables, charts, or schematics to represent physical situations.

2.C

Compare physical quantities between two or more scenarios or at different times and locations in a single scenario.

3.B

Apply an appropriate law, definition, theoretical relationship, or model to make a claim.

3.C

Justify or support a claim using evidence from experimental data, physical representations, or physical principles or laws.

SUGGESTED SKILLS

1.A

Create diagrams, tables, charts, or schematics to represent physical situations.

2.C

Compare physical quantities between two or more scenarios or at different times and locations in a single scenario.

3.B

Apply an appropriate law, definition, theoretical relationship, or model to make a claim.

3.C

Justify or support a claim using evidence from experimental data, physical representations, or physical principles or laws.

TOPIC 9.3

Thermal Energy Transfer and Equilibrium

Required Course Content

LEARNING OBJECTIVE

9.3.A

Describe the transfer of energy between two systems in thermal contact due to temperature differences of those two systems.

ESSENTIAL KNOWLEDGE

9.3.A.1

Two systems are in thermal contact if the systems may transfer energy by thermal processes.

9.3.A.1.i

Heating is the transfer of energy into a system by thermal processes.

9.3.A.1.ii

Cooling is the transfer of energy out of a system by thermal processes.

9.3.A.2

The thermal processes by which energy may be transferred between systems at different temperatures are conduction, convection, and radiation.

9.3.A.3

Energy is transferred through thermal processes spontaneously from a higher-temperature system to a lower-temperature system.

9.3.A.3.i

In collisions between atoms from different systems, energy is most likely to be transferred from higher-energy atoms to lower-energy atoms.

9.3.A.3.ii

After many collisions of atoms from different systems, the most probable state is one in which both systems have the same temperature.

9.3.A.4

Thermal equilibrium results when no net energy is transferred by thermal processes between two systems in thermal contact with each other.

TOPIC 9.4

The First Law of Thermodynamics

Required Course Content

LEARNING OBJECTIVE

9.4.A

Describe the internal energy of a system.

9.4.B

Describe the behavior of a system using thermodynamic processes.

ESSENTIAL KNOWLEDGE

9.4.A.1

The internal energy of a system is the sum of the kinetic energy of the objects that make up the system and the potential energy of the configuration of those objects.

9.4.A.1.i

The atoms in an ideal gas do not interact with each other via conservative forces, and the internal structure is not considered. Therefore, an ideal gas does not have internal potential energy.

9.4.A.1.ii

The internal energy of an ideal monatomic gas is the sum of the kinetic energies of the constituent atoms in the gas.

Relevant equation:

$$U = \frac{3}{2}nRT = \frac{3}{2}Nk_B T$$

9.4.A.2

Changes to a system's internal energy can result in changes to the internal structure and internal behavior of that system without changing the motion of the system's center of mass.

9.4.B.1

The first law of thermodynamics is a restatement of conservation of energy that accounts for energy transferred into or out of a system by work, heating, or cooling.

9.4.B.1.i

For an isolated system, the total energy is constant.

SUGGESTED SKILLS

1.C

Create qualitative sketches of graphs that represent features of a model or the behavior of a physical system.

2.A

Derive a symbolic expression from known quantities by selecting and following a logical mathematical pathway.

2.C

Compare physical quantities between two or more scenarios or at different times and locations in a single scenario.

3.C

Justify or support a claim using evidence from experimental data, physical representations, or physical principles or laws.

continued on next page

LEARNING OBJECTIVE

9.4.B

Describe the behavior of a system using thermodynamic processes.

ESSENTIAL KNOWLEDGE

9.4.B.1.ii

For a closed system, the change in internal energy is the sum of energy transferred to or from the system by heating, or work done on the system.

Relevant equation:

$$\Delta U = Q + W$$

9.4.B.1.iii

The work done on a system by a constant or average external pressure that changes the volume of that system (for example, a piston compressing a gas in a container) is defined as

$$W = -P\Delta V.$$

9.4.B.2

Pressure-volume graphs (also known as PV diagrams) are representations used to represent thermodynamic processes.

9.4.B.2.i

Lines of constant temperature on a PV diagram are called isotherms.

9.4.B.2.ii

The absolute value of the work done on a gas when the gas expands or compresses is equal to the area underneath the curve of a plot of pressure vs. volume for the gas.

9.4.B.3

Special cases of thermal processes depend on the relationship between the configuration of the system, the nature of the work done on the system, and the system's surroundings. These include constant volume (isovolumetric), constant temperature (isothermal), and constant pressure (isobaric), as well as processes where no energy is transferred to or from the system through thermal processes (adiabatic).

TOPIC 9.5

Specific Heat and Thermal Conductivity

Required Course Content

LEARNING OBJECTIVE

9.5.A

Describe the energy required to change the temperature of an object by a certain amount.

9.5.B

Describe the rate at which energy is transferred by conduction through a given material.

ESSENTIAL KNOWLEDGE

9.5.A.1

The amount of energy required to change the temperature of a material is related to the material's specific heat.

Relevant equation:

$$Q = mc\Delta T$$

9.5.A.2

The specific heat of a material is an intrinsic property of that material that depends on the arrangement and interactions of the atoms that make up the material.

9.5.B.1

The rate at which energy is transferred by conduction through a given material is related to the thermal conductivity, the physical dimensions of the material, and the temperature difference across the material.

Relevant equation:

$$\frac{Q}{\Delta t} = \frac{kA\Delta T}{L}$$

9.5.B.2

The thermal conductivity of a material is an intrinsic property of that material that depends on the arrangement and interactions of the atoms that make up the material.

BOUNDARY STATEMENT

AP Physics 2 will model specific heat as independent of temperature.

SUGGESTED SKILLS

1.B

Create quantitative graphs with appropriate scales and units, including plotting data.

2.B

Calculate or estimate an unknown quantity with units from known quantities, by selecting and following a logical computational pathway.

2.D

Predict new values or factors of change of physical quantities using functional dependence between variables.

3.A

Create experimental procedures that are appropriate for a given scientific question.

3.B

Apply an appropriate law, definition, theoretical relationship, or model to make a claim.

SUGGESTED SKILLS

1.A

Create diagrams, tables, charts, or schematics to represent physical situations.

2.C

Compare physical quantities between two or more scenarios or at different times and locations in a single scenario.

3.B

Apply an appropriate law, definition, theoretical relationship, or model to make a claim.

3.C

Justify or support a claim using evidence from experimental data, physical representations, or physical principles or laws.

TOPIC 9.6

Entropy and the Second Law of Thermodynamics

Required Course Content

LEARNING OBJECTIVE

9.6.A

Describe the change in entropy for a given system over time.

ESSENTIAL KNOWLEDGE

9.6.A.1

The second law of thermodynamics states that the total entropy of an isolated system can never decrease and is constant only when all processes the system undergoes are reversible.

9.6.A.2

Entropy can be qualitatively described as the tendency of energy to spread or the unavailability of some of the system's energy to do work.

9.6.A.2.i

Localized energy will tend to disperse and spread out.

9.6.A.2.ii

Entropy is a state function and therefore only depends on the current state or configuration of a system, not how the system reached that state.

9.6.A.2.iii

Maximum entropy occurs when a system is in thermodynamic equilibrium.

9.6.A.3

The change in a system's entropy is determined by the system's interactions with its surroundings.

9.6.A.3.i

Closed systems spontaneously move toward thermodynamic equilibrium.

continued on next page

LEARNING OBJECTIVE

9.6.A

Describe the change in entropy for a given system over time.

ESSENTIAL KNOWLEDGE

9.6.A.3.ii

The entropy of a closed system never decreases, but the entropy of an open system can decrease because energy can be transferred into or out of the system.

BOUNDARY STATEMENT

Only qualitative treatment of the second law of thermodynamics is within the scope of AP Physics 2.

THIS PAGE IS INTENTIONALLY LEFT BLANK.

AP PHYSICS 2

UNIT 10

Electric Force, Field, and Potential



15–18%
AP EXAM WEIGHTING



~14–21
CLASS PERIODS

The icon consists of a white circle containing a blue square with the letters 'AP' in white. Below the square is a blue horizontal line with a small vertical tick mark in the center, resembling a computer monitor or a document icon.

Remember to go to [AP Classroom](#) to assign students the online **Progress Check** for this unit.

Whether assigned as homework or completed in class, the **Progress Check** provides each student with immediate feedback related to this unit's topics and science practices.

Progress Check 10

Multiple-choice: ~24 questions

Free-response: 4 questions

- Mathematical Routines
- Translation Between Representations
- Experimental Design and Analysis
- Qualitative/Quantitative Translation

Electric Force, Field, and Potential



Developing Understanding

ESSENTIAL QUESTIONS

- How can you suspend a charged water droplet in the air?
- Since balloons are made of rubber, how can they be “charged” so that they stick to the wall?
- Where is the safest place to be during a lightning storm?
- How can you protect your electronics from an EMP?

Unit 10 begins the study of electrostatic phenomena at a fundamental level, introducing students to the model of field forces. Despite the topical shift from gases to charged particles, this unit continues the study of interactions and change. Unit 10 reinforces the idea that interactions can be described by forces, and that the electric force, like the other forces introduced in AP Physics 1, can be described with Newton’s laws. Students are encouraged to apply fundamental physics principles studied in AP Physics 1 when learning about fields (gravitational and electric) and the forces experienced by objects in a field.

Building the Science Practices

1.A 1.C 2.A

Throughout this unit, there are many opportunities for students to create graphs (1.C), and to make connections between physics concepts based on these graphs. In Unit 10, as in other units in AP Physics 2, practice creating and using models to represent physical scenarios (1.A) and then translating the information presented in these models into other representations—such as symbolic expressions (2.A)—can help students justify or support claims about electrically charged systems. Examples of representations used to model ideas in Unit 10 include but are not limited to - pictures, motion diagrams, free-body diagrams, graphs, energy bar charts, electric field vector diagrams, and equipotential diagrams.

Preparing for the AP Exam

The second free-response question on the AP Physics 2 Exam—the Translation Between Representations (TBR) question—requires students to create graphical and verbal models of scenarios, as well as compare these models to mathematical representations of the same situation. Similar in nature to the Qualitative/Quantitative Translation (QQT) question, the TBR involves creating multiple representations and describing the relationships between those representations; however, the types of representations being compared in the TBR differ from those in the QQT. In the TBR, a student might be asked to sketch equipotential lines around a small, positively charged sphere. The student might then be asked to create energy bar charts to model the energy of a system containing a small point charge that is released from rest and the charged sphere. Lastly, the student might be asked to make connections between the two representations, explaining how the representations are consistent with each other. While Unit 10 content provides especially good practice for the TBR, content from any unit may be included in this free-response question on the AP Exam.

UNIT AT A GLANCE

Topic	Suggested Skills
10.1 Electric Charge and Electric Force	<p>1.A Create diagrams, tables, charts, or schematics to represent physical situations.</p> <p>2.A Derive a symbolic expression from known quantities by selecting and following a logical mathematical pathway.</p> <p>2.D Predict new values or factors of change of physical quantities using functional dependence between variables.</p> <p>3.B Apply an appropriate law, definition, theoretical relationship, or model to make a claim.</p>
10.2 Conservation of Electric Charge and the Process of Charging	<p>1.A Create diagrams, tables, charts, or schematics to represent physical situations.</p> <p>2.C Compare physical quantities between two or more scenarios or at different times and locations in a single scenario.</p> <p>3.B Apply an appropriate law, definition, theoretical relationship, or model to make a claim.</p> <p>3.C Justify or support a claim using evidence from experimental data, physical representations, or physical principles or laws.</p>
10.3 Electric Fields	<p>1.A Create diagrams, tables, charts, or schematics to represent physical situations.</p> <p>2.A Derive a symbolic expression from known quantities by selecting and following a logical mathematical pathway.</p> <p>2.B Calculate or estimate an unknown quantity with units from known quantities, by selecting and following a logical computational pathway.</p> <p>3.B Apply an appropriate law, definition, theoretical relationship, or model to make a claim.</p>
10.4 Electric Potential Energy	<p>1.C Create qualitative sketches of graphs that represent features of a model or the behavior of a physical system.</p> <p>2.A Derive a symbolic expression from known quantities by selecting and following a logical mathematical pathway.</p> <p>2.D Predict new values or factors of change of physical quantities using functional dependence between variables.</p> <p>3.C Justify or support a claim using evidence from experimental data, physical representations, or physical principles or laws.</p>

continued on next page

UNIT AT A GLANCE *(cont'd)*

Topic	Suggested Skills
10.5 Electric Potential	<p>1.A Create diagrams, tables, charts, or schematics to represent physical situations.</p> <p>2.A Derive a symbolic expression from known quantities by selecting and following a logical mathematical pathway.</p> <p>2.C Compare physical quantities between two or more scenarios or at different times and locations in a single scenario.</p> <p>3.B Apply an appropriate law, definition, theoretical relationship, or model to make a claim.</p>
10.6 Capacitors	<p>1.B Create quantitative graphs with appropriate scales and units, including plotting data.</p> <p>2.B Calculate or estimate an unknown quantity with units from known quantities, by selecting and following a logical computational pathway.</p> <p>2.C Compare physical quantities between two or more scenarios or at different times and locations in a single scenario.</p> <p>3.A Create experimental procedures that are appropriate for a given scientific question.</p> <p>3.C Justify or support a claim using evidence from experimental data, physical representations, or physical principles or laws.</p>
10.7 Conservation of Electric Energy	<p>1.C Create qualitative sketches of graphs that represent features of a model or the behavior of a physical system.</p> <p>2.A Derive a symbolic expression from known quantities by selecting and following a logical mathematical pathway.</p> <p>2.C Compare physical quantities between two or more scenarios or at different times and locations in a single scenario.</p> <p>3.C Justify or support a claim using evidence from experimental data, physical representations, or physical principles or laws.</p>



Go to [AP Classroom](#) to assign the **Progress Check** for Unit 10.
Review the results in class to identify and address any student misunderstandings.

SAMPLE INSTRUCTIONAL ACTIVITIES

The sample activities on this page are optional and are offered to provide possible ways to incorporate instructional approaches into the classroom. Teachers do not need to use these activities or instructional approaches and are free to alter or edit them. The examples below were developed in partnership with teachers from the AP community to share ways that they approach teaching some of the topics in this unit. Please refer to the Instructional Approaches section beginning on p. 167 for more examples of activities and strategies.

Activity	Topic	Sample Activity
1	10.1	Identify Subtasks Show students three known charges at known positions on a line and ask the students to find the net force on each charge. Have students describe in words what the subtasks are and have them come up with a procedure for finding the net force on each charge.
2	10.1	Conflicting Contentions Show students a diagram with two charged spheres, A and B, hanging from strings anchored to the same point in the ceiling, with the string for sphere A making a greater angle from the vertical. One student thinks this is because A has less charge so it is pushed on harder by B, but another student thinks it is because A has less mass and is pulled down less by gravity. Which student is right? Have students justify which student is correct by drawing free-body diagrams to support their claim. with free body diagrams.
3	10.1	Friends without Pens Have students consider a proton P and an alpha particle A released from rest near each other. Relate the electric and gravitational forces of P on A and A on P. Rank these four forces and justify the ranking. How does the acceleration/momentum/kinetic energy of P compare to (four times as much, same, one quarter as much)? How does the acceleration and velocity of P or A change as they move apart? Allow students to consider these questions in a group and then have them move back to their desks to complete the rankings and justifications.
4	10.3	Changing Representations Given an arrangement of two or three charges (of various signs and either same or different magnitude), ask students to sketch E-field vector diagrams and potential isolines for the arrangement. Students can use PhET: Charges and Fields to check their diagrams.
5	10.5	Desktop Experiment Tasks A spark occurs when the electric field between two conductors is $3 \times 10^6 \frac{\text{V}}{\text{m}}$. Obtain a Van de Graaf generator and find the distance from the ball that a grounded rod must be held to make a spark. Have students use $E = \frac{V}{d}$ to get the potential of the sphere, and use $V = \frac{kq}{r}$ with the radius of the sphere to get the charge of the sphere.

TOPIC 10.1

Electric Charge and Electric Force**Required Course Content****LEARNING OBJECTIVE****10.1.A**

Describe the electric force that results from the interactions between charged objects or systems.

ESSENTIAL KNOWLEDGE**10.1.A.1**

Charge is a fundamental property of all matter.

10.1.A.1.i

Charge is described as positive or negative.

10.1.A.1.ii

The magnitude of the charge of a single electron or proton, the elementary charge e , can be considered to be the smallest indivisible amount of charge.

10.1.A.1.iii

The charge of an electron is $-e$, the charge of a proton is $+e$, and a neutron has no electric charge.

10.1.A.1.iv

A point charge is a model in which the physical size of a charged object or system is negligible in the context of the situation being analyzed.

10.1.A.2

Coulomb's law describes the electrostatic force between two charged objects as directly proportional to the magnitude of each of the charges and inversely proportional to the square of the distance between the objects.

Relevant equation:

$$|\vec{F}_E| = \frac{1}{4\pi\epsilon_0} \frac{|q_1q_2|}{r^2} = k \frac{|q_1q_2|}{r^2}$$

SUGGESTED SKILLS**1.A**

Create diagrams, tables, charts, or schematics to represent physical situations.

2.A

Derive a symbolic expression from known quantities by selecting and following a logical mathematical pathway.

2.D

Predict new values or factors of change of physical quantities using functional dependence between variables.

3.B

Apply an appropriate law, definition, theoretical relationship, or model to make a claim.

continued on next page

LEARNING OBJECTIVE

10.1.A

Describe the electric force that results from the interactions between charged objects or systems

10.1.B

Describe the electric and gravitational forces that result from interactions between charged objects with mass.

10.1.C

Describe the electric permittivity of a material or medium.

ESSENTIAL KNOWLEDGE

10.1.A.3

The direction of the electrostatic force depends on the signs of the charges of the interacting objects and is parallel to the line of separation between the objects.

10.1.A.3.i

Two objects with charges of the same sign exert repulsive forces on each other.

10.1.A.3.ii

Two objects with charges of opposite signs exert attractive forces on each other.

10.1.A.4

Electric forces are responsible for some of the macroscopic properties of objects in everyday experiences. However, the large number of particle interactions that occur make it more convenient to treat everyday forces in terms of nonfundamental forces called contact forces, such as normal force, friction, and tension.

10.1.B.1

Electrostatic forces can be attractive or repulsive, while gravitational forces are always attractive.

10.1.B.2

For any two objects that have mass and electric charge, the magnitude of the gravitational force is usually much smaller than the magnitude of the electrostatic force.

10.1.B.3

Gravitational forces dominate at larger scales even though they are weaker than electrostatic forces, because systems at large scales tend to be electrically neutral.

10.1.C.1

Electric permittivity is a measurement of the degree to which a material or medium is polarized in the presence of an electric field.

10.1.C.2

Electric polarization can be modeled as the induced rearrangement of electrons by an external electric field, resulting in a separation of positive and negative charges within a material or medium.

continued on next page

LEARNING OBJECTIVE

10.1.C

Describe the electric permittivity of a material or medium.

ESSENTIAL KNOWLEDGE

10.1.C.3

Free space has a constant value of electric permittivity, ϵ_0 , that appears in physical relationships.

10.1.C.4

The permittivity of matter has a value different from that of free space that arises from the matter's composition and arrangement.

10.1.C.4.i

In a given material, electric permittivity is determined by the ease with which electrons can change configurations within the material.

10.1.C.4.ii

Conductors are made from electrically conducting materials in which charge carriers move easily; insulators are made from electrically nonconducting materials in which charge carriers cannot move easily.

BOUNDARY STATEMENT

AP Physics 2 only expects students to make calculations of the electric force between four or fewer interacting charged objects or systems. The analysis of the resulting electric force from more charges is allowed in situations of high symmetry.

SUGGESTED SKILLS

1.A

Create diagrams, tables, charts, or schematics to represent physical situations.

2.C

Compare physical quantities between two or more scenarios or at different times and locations in a single scenario.

3.B

Apply an appropriate law, definition, theoretical relationship, or model to make a claim.

3.C

Justify or support a claim using evidence from experimental data, physical representations, or physical principles or laws.

TOPIC 10.2

Conservation of Electric Charge and the Process of Charging

Required Course Content

LEARNING OBJECTIVE

10.2.A

Describe the behavior of a system using conservation of charge.

ESSENTIAL KNOWLEDGE

10.2.A.1

The net charge or charge distribution of a system can change in response to the presence of, or changes in, the net charge or charge distribution of other systems.

10.2.A.1.i

The net charge of a system can change due to friction or contact between systems.

10.2.A.1.ii

Induced charge separation occurs when the electrostatic force between two systems alters the distribution of charges within the systems, resulting in the polarization of one or both systems.

10.2.A.1.iii

Induced charge separation can occur in neutral systems.

10.2.A.2

Any change to a system's net charge is due to a transfer of charge between the system and its surroundings.

10.2.A.2.i

The charging of a system typically involves the transfer of electrons to and from the system.

10.2.A.2.ii

The net charge of a system will be constant unless there is a transfer of charge to or from the system.

10.2.A.3

Grounding involves electrically connecting a charged system to a much larger and approximately neutral system (e.g., Earth).

TOPIC 10.3

Electric Fields

SUGGESTED SKILLS

1.A

Create diagrams, tables, charts, or schematics to represent physical situations.

2.A

Derive a symbolic expression from known quantities by selecting and following a logical mathematical pathway.

2.B

Calculate or estimate an unknown quantity with units from known quantities, by selecting and following a logical computational pathway.

3.B

Apply an appropriate law, definition, theoretical relationship, or model to make a claim.

Required Course Content

LEARNING OBJECTIVE

10.3.A

Describe the electric field produced by a charged object or configuration of point charges.

ESSENTIAL KNOWLEDGE

10.3.A.1

Electric fields may originate from charged objects.

10.3.A.2

The electric field at a given point is the ratio of the electric force exerted on a test charge at that point to the charge of the test charge.

Relevant equation:

$$\vec{E} = \frac{\vec{F}_E}{q}$$

10.3.A.2.i

A test charge is a point charge of small enough magnitude such that its presence does not significantly affect an electric field in its vicinity.

10.3.A.2.ii

An electric field points away from isolated positive charges and toward isolated negative charges.

10.3.A.2.iii

The electric force exerted on a positive test charge by an electric field is in the same direction as the electric field.

10.3.A.3

The electric field is a vector quantity and can be represented in space using vector field maps.

continued on next page

LEARNING OBJECTIVE

10.3.A

Describe the electric field produced by a charged object or configuration of point charges.

10.3.B

Describe the electric field generated by charged conductors or insulators.

ESSENTIAL KNOWLEDGE

10.3.A.3.i

The net electric field at a given location is the vector sum of individual electric fields created by nearby charged objects.

10.3.A.3.ii

Electric field maps use vectors to depict the magnitude and direction of the electric field at many locations within a given region.

10.3.A.3.iii

Electric field line diagrams are simplified models of electric field maps and can be used to determine the relative magnitude and direction of the electric field at any position in the diagram.

10.3.B.1

While in electrostatic equilibrium, the excess charge of a solid conductor is distributed on the surface of the conductor, and the electric field within the conductor is zero.

10.3.B.1.i

At the surface of a charged conductor, the electric field is perpendicular to the surface.

10.3.B.1.ii

The electric field outside an isolated sphere with spherically symmetric charge distribution is the same as the electric field due to a point charge with the same net charge as the sphere located at the center of the sphere.

10.3.B.2

While in electrostatic equilibrium, the excess charge of an insulator is distributed throughout the interior of the insulator as well as at the surface, and the electric field within the insulator may have a nonzero value.

BOUNDARY STATEMENT

AP Physics 2 only expects students to make calculations of the electric field resulting from four or fewer charged objects or systems. Analysis of the electric field resulting from more charges is allowed in situations of high symmetry. Students will only be expected to perform qualitative analysis of electric fields within insulators.

TOPIC 10.4

Electric Potential Energy**Required Course Content****LEARNING OBJECTIVE****10.4.A**

Describe the electric potential energy of a system.

ESSENTIAL KNOWLEDGE**10.4.A.1**

The electric potential energy of a system of two point charges equals the amount of work required for an external force to bring the point charges to their current positions from infinitely far away.

10.4.A.2

The general form for the electric potential energy of two charged objects is given by the equation

$$U_E = \frac{1}{4\pi\epsilon_0} \frac{q_1 q_2}{r} = k \frac{q_1 q_2}{r}.$$

10.4.A.3

The total electric potential energy of a system can be determined by finding the sum of the electric potential energies of the individual interactions between each pair of charged objects in the system.

BOUNDARY STATEMENT

As the methods to calculate the electric potential energy due to extended charge distributions exceed the scope of the course, AP Physics 2 only requires that students calculate the electric potential energy of configurations of four or fewer point charges.

SUGGESTED SKILLS**1.C**

Create qualitative sketches of graphs that represent features of a model or the behavior of a physical system.

2.A

Derive a symbolic expression from known quantities by selecting and following a logical mathematical pathway.

2.D

Predict new values or factors of change of physical quantities using functional dependence between variables.

3.C

Justify or support a claim using evidence from experimental data, physical representations, or physical principles or laws.

SUGGESTED SKILLS

1.A

Create diagrams, tables, charts, or schematics to represent physical situations.

2.A

Derive a symbolic expression from known quantities by selecting and following a logical mathematical pathway.

2.C

Compare physical quantities between two or more scenarios or at different times and locations in a single scenario.

3.B

Apply an appropriate law, definition, theoretical relationship, or model to make a claim.

TOPIC 10.5

Electric Potential

Required Course Content

LEARNING OBJECTIVE

10.5.A

Describe the electric potential due to a configuration of charged objects.

ESSENTIAL KNOWLEDGE

10.5.A.1

Electric potential describes the electric potential energy per unit charge at a point in space.

10.5.A.2

The electric potential due to multiple point charges can be determined by the principle of scalar superposition of the electric potential due to each of the point charges.

Relevant equation:

$$V = \frac{1}{4\pi\epsilon_0} \sum_i \frac{q_i}{r_i}$$

10.5.A.3

The electric potential difference between two points is the change in electric potential energy per unit charge when a test charge is moved between the two points.

Relevant equation:

$$\Delta V = \frac{\Delta U_E}{q}$$

10.5.A.3.i

Electric potential difference may also result from chemical processes that cause positive and negative charges to separate, such as in a battery.

10.5.A.4

When conductors are in electrical contact, electrons will be redistributed such that the surfaces of the conductors are at the same electric potential.

continued on next page

LEARNING OBJECTIVE**10.5.B**

Describe the relationship between electric potential and electric field.

ESSENTIAL KNOWLEDGE**10.5.B.1**

The average electric field between two points in space is equal to the electric potential difference between the two points divided by the distance between the two points.

Relevant equation:

$$|\vec{E}| = \left| \frac{\Delta V}{\Delta r} \right|$$

10.5.B.2

Electric field vector maps and equipotential lines are tools to describe the field produced by a charge or configuration of charges and can be used to predict the motion of charged objects in the field.

10.5.B.2.i

Equipotential lines represent lines of equal electric potential in space. These lines are also referred to as isolines of electric potential.

10.5.B.2.ii

Isolines are perpendicular to electric field vectors. An isoline map of electric potential can be constructed from an electric field vector map, and an electric field map may be constructed from an isoline map.

10.5.B.2.iii

An electric field vector points in the direction of decreasing potential.

10.5.B.2.iv

There is no component of an electric field along an isoline.

BOUNDARY STATEMENT

As the methods to calculate the electric potential due to extended charges exceed the scope of the course, AP Physics 2 only expects that students calculate the electric potential of configurations of four or fewer particles (or more in situations of high symmetry).

SUGGESTED SKILLS

1.B

Create quantitative graphs with appropriate scales and units, including plotting data.

2.B

Calculate or estimate an unknown quantity with units from known quantities, by selecting and following a logical computational pathway.

2.C

Compare physical quantities between two or more scenarios or at different times and locations in a single scenario.

3.A

Create experimental procedures that are appropriate for a given scientific question.

3.C

Justify or support a claim using evidence from experimental data, physical representations, or physical principles or laws.

TOPIC 10.6

Capacitors

Required Course Content

LEARNING OBJECTIVE

10.6.A

Describe the physical properties of a parallel-plate capacitor.

ESSENTIAL KNOWLEDGE

10.6.A.1

A parallel-plate capacitor consists of two separated parallel conducting surfaces that can hold equal amounts of charge with opposite signs.

10.6.A.2

Capacitance relates the magnitude of the charge stored on each plate to the electric potential difference created by the separation of those charges.

Relevant equation:

$$C = \frac{Q}{\Delta V}$$

10.6.A.2.i

The capacitance of a capacitor depends only on the physical properties of the capacitor, such as the capacitor's shape and the material used to separate the plates.

10.6.A.2.ii

The capacitance of a parallel-plate capacitor is proportional to the area of one of its plates and inversely proportional to the distance between its plates. The constant of proportionality is the product of the dielectric constant, κ , of the material between the plates and the electric permittivity of free space, ϵ_0 .

Relevant equation:

$$C = \kappa \epsilon_0 \frac{A}{d}$$

continued on next page

LEARNING OBJECTIVE**10.6.A**

Describe the physical properties of a parallel-plate capacitor.

ESSENTIAL KNOWLEDGE**10.6.A.3**

The electric field between two charged parallel plates with uniformly distributed electric charge, such as in a parallel-plate capacitor, is constant in both magnitude and direction, except near the edges of the plates.

10.6.A.3.i

The magnitude of the electric field between two charged parallel plates, where the plate separation is much smaller than the dimensions of the plates, can be described with the equation

$$E_c = \frac{Q}{\kappa\epsilon_0 A}.$$

10.6.A.3.ii

A charged particle between two oppositely charged parallel plates undergoes constant acceleration and therefore its motion shares characteristics with the projectile motion of an object with mass in the gravitational field near Earth's surface.

10.6.A.4

The electric potential energy stored in a capacitor is equal to the work done by an external force to separate that amount of charge on the capacitor.

10.6.A.5

The electric potential energy stored in a capacitor is described by the equation

$$U_c = \frac{1}{2}Q\Delta V.$$

10.6.A.6

Adding a dielectric between two plates of a capacitor changes the capacitance of the capacitor and induces an electric field in the dielectric in the opposite direction to the field between the plates.

BOUNDARY STATEMENT

While other shapes are also able to separate charges, only the analysis and descriptions of parallel-plate capacitors are required for AP Physics 2. Edge effects will be ignored unless explicitly stated otherwise.

SUGGESTED SKILLS

1.C

Create qualitative sketches of graphs that represent features of a model or the behavior of a physical system.

2.A

Derive a symbolic expression from known quantities by selecting and following a logical mathematical pathway.

2.C

Compare physical quantities between two or more scenarios or at different times and locations in a single scenario.

3.C

Justify or support a claim using evidence from experimental data, physical representations, or physical principles or laws.

TOPIC 10.7

Conservation of Electric Energy

Required Course Content

LEARNING OBJECTIVE

10.7.A

Describe changes in energy in a system due to a difference in electric potential between two locations.

ESSENTIAL KNOWLEDGE

10.7.A.1

When a charged object moves between two locations with different electric potentials, the resulting change in the electric potential energy of the object-field system is given by the following equation.

Relevant equation:

$$\Delta U_E = q\Delta V$$

10.7.A.2

The movement of a charged object between two points with different electric potentials results in a change in kinetic energy of the object consistent with the conservation of energy.

AP PHYSICS 2

UNIT 11

Electric Circuits



15–18%
AP EXAM WEIGHTING



~12–20
CLASS PERIODS

The icon consists of a white circle containing a blue square with the letters 'AP' in white. Below the square is a blue horizontal line with a small vertical tick mark in the center.

Remember to go to [AP Classroom](#) to assign students the online **Progress Check** for this unit.

Whether assigned as homework or completed in class, the **Progress Check** provides each student with immediate feedback related to this unit's topics and science practices.

Progress Check 11

Multiple-choice: ~24 questions

Free-response: 4 questions

- Mathematical Routines
- Translation Between Representations
- Experimental Design and Analysis
- Qualitative/Quantitative Translation

Electric Circuits



Developing Understanding

ESSENTIAL QUESTIONS

- Why do lights on electronics dim slowly and then go out when unplugged?
- Why do several bulbs on a string of lights go out when one bulb is unplugged?
- How can we effectively store electrical energy to use later?
- How can you make a 120 Watt bulb brighter than a 40 Watt bulb?

Unit 11 revisits the behavior of charged particles to deepen students' understanding of the law of conservation of energy and its application to electric circuits. This unit requires more than calculating currents, resistances, and potential differences in a simple circuit. For example, students must be able to articulate the impact of a light bulb being removed from a circuit. They should also practice designing an experiment, for example, to test if a light bulb is ohmic or justify how and why circuit elements in series and parallel affect the properties of a circuit. In Unit 12, students will expand their investigations of the similarities and differences between electric and magnetic fields.

Building the Science Practices

1.A 1.B 2.B 2.D 3.A

Unit 11 provides opportunities for students to practice writing clear concise experimental procedures that are appropriate for a given scientific question (**3.A**), as well as creating and using graphs (**1.B**) of collected data. Analyzing experimental data can be challenging and students may benefit from multiple opportunities to create graphs and analyze data. (**2.B, 2.D**). These important skills will be tested on the free-response section of the AP Physics 2 Exam.

Preparing for the AP Exam

Throughout their study of physics, students may need to reflect upon common misconceptions. For example, the students may believe that batteries store charge, or that current is used up in a circuit. Misconceptions can be challenged by encouraging students to identify the fundamental physical principle needed to answer a question, which will help them eliminate irrelevant or extraneous information. On the AP Physics 2 Exam, it is also important that students use correct vocabulary and terminology when defending claims with evidence. Students can inadvertently miscommunicate their answers by using words incorrectly or not fully understanding their nuances. For example, students should know the differences in meaning between “current”, “potential difference”, “resistance”, “resistivity”, and “capacitance.” Scaffolded instruction in using the correct vocabulary and writing clear, concise explanations will help students be more successful on the free-response section of the AP Exam, where written expression and justification represents many of the available points.

UNIT AT A GLANCE

Topic	Suggested Skills
11.1 Electric Current	<p>1.A Create diagrams, tables, charts, or schematics to represent physical situations.</p> <p>2.C Compare physical quantities between two or more scenarios or at different times and locations in a single scenario.</p> <p>3.B Apply an appropriate law, definition, theoretical relationship, or model to make a claim.</p> <p>3.C Justify or support a claim using evidence from experimental data, physical representations, or physical principles or laws.</p>
11.2 Simple Circuits	<p>1.A Create diagrams, tables, charts, or schematics to represent physical situations.</p> <p>2.C Compare physical quantities between two or more scenarios or at different times and locations in a single scenario.</p> <p>3.B Apply an appropriate law, definition, theoretical relationship, or model to make a claim.</p> <p>3.C Justify or support a claim using evidence from experimental data, physical representations, or physical principles or laws.</p>
11.3 Resistance, Resistivity, and Ohm's Law	<p>1.B Create quantitative graphs with appropriate scales and units, including plotting data.</p> <p>2.B Calculate or estimate an unknown quantity with units from known quantities, by selecting and following a logical computational pathway.</p> <p>2.D Predict new values or factors of change of physical quantities using functional dependence between variables.</p> <p>3.A Create experimental procedures that are appropriate for a given scientific question.</p> <p>3.B Apply an appropriate law, definition, theoretical relationship, or model to make a claim.</p>
11.4 Electric Power	<p>1.C Create qualitative sketches of graphs that represent features of a model or the behavior of a physical system.</p> <p>2.A Derive a symbolic expression from known quantities by selecting and following a logical mathematical pathway.</p> <p>2.D Predict new values or factors of change of physical quantities using functional dependence between variables.</p> <p>3.C Justify or support a claim using evidence from experimental data, physical representations, or physical principles or laws.</p>

continued on next page

UNIT AT A GLANCE *(cont'd)*

Topic	Suggested Skills
11.5 Compound Direct Current (DC) Circuits	<p>1.A Create diagrams, tables, charts, or schematics to represent physical situations.</p> <p>2.A Derive a symbolic expression from known quantities by selecting and following a logical mathematical pathway.</p> <p>2.C Compare physical quantities between two or more scenarios or at different times and locations in a single scenario.</p> <p>3.B Apply an appropriate law, definition, theoretical relationship, or model to make a claim.</p>
11.6 Kirchhoff's Loop Rule	<p>1.C Create qualitative sketches of graphs that represent features of a model or the behavior of a physical system.</p> <p>2.A Derive a symbolic expression from known quantities by selecting and following a logical mathematical pathway.</p> <p>2.C Compare physical quantities between two or more scenarios or at different times and locations in a single scenario.</p> <p>3.B Apply an appropriate law, definition, theoretical relationship, or model to make a claim.</p>
11.7 Kirchhoff's Junction Rule	<p>1.A Create diagrams, tables, charts, or schematics to represent physical situations.</p> <p>2.B Calculate or estimate an unknown quantity with units from known quantities, by selecting and following a logical computational pathway.</p> <p>2.C Compare physical quantities between two or more scenarios or at different times and locations in a single scenario.</p> <p>3.C Justify or support a claim using evidence from experimental data, physical representations, or physical principles or laws.</p>
11.8 Resistor-Capacitor (RC) Circuits	<p>1.B Create quantitative graphs with appropriate scales and units, including plotting data.</p> <p>1.C Create qualitative sketches of graphs that represent features of a model or the behavior of a physical system.</p> <p>2.A Derive a symbolic expression from known quantities by selecting and following a logical mathematical pathway.</p> <p>2.D Predict new values or factors of change of physical quantities using functional dependence between variables.</p> <p>3.A Create experimental procedures that are appropriate for a given scientific question.</p> <p>3.C Justify or support a claim using evidence from experimental data, physical representations, or physical principles or laws.</p>



Go to **AP Classroom** to assign the **Progress Check** for Unit 11.
Review the results in class to identify and address any student misunderstandings.

SAMPLE INSTRUCTIONAL ACTIVITIES

The sample activities on this page are optional and are offered to provide possible ways to incorporate instructional approaches into the classroom. Teachers do not need to use these activities or instructional approaches and are free to alter or edit them. The examples below were developed in partnership with teachers from the AP community to share ways that they approach teaching some of the topics in this unit. Please refer to the Instructional Approaches section beginning on p. 167 for more examples of activities and strategies.

Activity	Topic	Sample Activity
1	11.3	Conflicting Contentions Provide students with the following scenario: Students A and B are trying to heat water by connecting mechanical pencil lead directly to a battery and immersing the lead in water. To heat the water in less time, Student A says that 0.7 mm pencil lead should be used so that charges flow better, but Student B says that 0.5 mm pencil lead will have a greater resistance. Ask students to resolve this conflict using equations and qualitative reasoning. Ask students to justify their claims with evidence.
2	11.3	Working Backwards/Graph and Switch Break students into groups of two. Each group should create a table of potential differences and currents for four or five ohmic resistors in a circuit. Have the groups switch data tables with another groups and then ask the students to draw the circuit diagram that corresponds to the other group's data table, complete with resistance values and battery voltages.
3	11.3	Desktop Experiment Tasks Ask students to connect a 0.5 mm or 0.7 mm mechanical pencil lead in series with a 1000 ohm resistor and a 1.5 V battery. Have students measure the potential difference across and current in the lead, and then determine the resistivity of the graphite. Have students practice writing experimental procedures by writing up the procedure for their experiment.
4	11.5	Desktop Experiment Tasks Have students connect a 1.5 V battery to five light bulbs in parallel. Ask students to measure the potential difference across and current through the battery and then make a graph whose slope is the internal resistance of the battery. Students can practice their data analysis by determining the internal resistance of their battery. Ask groups to compare the individual internal resistances of the different batteries, and come up with reasons why they are the same or different.
5	11.7	Predict and Explain Break students into groups of 3-4 students, and set up a mixed circuit with a battery and three or four light bulbs for each group. Ask students to predict what happens to the brightness of each of the remaining bulbs if one is removed, and explain using Kirchhoff's principles. Alternately, ask what bulbs must be removed to make another bulb brighter or dimmer.

TOPIC 11.1

Electric Current

Required Course Content

LEARNING OBJECTIVE

11.1.A

Describe the movement of electric charges through a medium.

ESSENTIAL KNOWLEDGE

11.1.A.1

Current is the rate at which charge passes through a cross-sectional area of a wire.

Relevant equation:

$$I = \frac{\Delta q}{\Delta t}$$

11.1.A.1.i

Electric charge moves in a circuit in response to an electric potential difference, sometimes referred to as electromotive force, or emf (\mathcal{E}).

11.1.A.1.ii

If the current is zero in a section of wire, the net motion of charge carriers in the wire is also zero, although individual charge carriers will not have zero speed.

11.1.A.2

Although current is not a vector quantity, it does have a direction. The direction of current is associated with what the motion of positive charge would be but not with any coordinate system in space.

11.1.A.2.i

The direction of conventional current is chosen to be the direction in which positive charge would move.

11.1.A.2.ii

In common circuits, current is actually due to the movement of electrons (negative charge carriers).

SUGGESTED SKILLS

1.A

Create diagrams, tables, charts, or schematics to represent physical situations.

2.C

Compare physical quantities between two or more scenarios or at different times and locations in a single scenario.

3.B

Apply an appropriate law, definition, theoretical relationship, or model to make a claim.

3.C

Justify or support a claim using evidence from experimental data, physical representations, or physical principles or laws.

SUGGESTED SKILLS

1.A

Create diagrams, tables, charts, or schematics to represent physical situations.

2.C

Compare physical quantities between two or more scenarios or at different times and locations in a single scenario.

3.B

Apply an appropriate law, definition, theoretical relationship, or model to make a claim.

3.C

Justify or support a claim using evidence from experimental data, physical representations, or physical principles or laws.

TOPIC 11.2

Simple Circuits

Required Course Content

LEARNING OBJECTIVE

11.2.A

Describe the behavior of a circuit.

ESSENTIAL KNOWLEDGE

11.2.A.1

A circuit is composed of electrical loops, which may include circuit elements such as wires, batteries, resistors, lightbulbs, capacitors, switches, ammeters, and voltmeters.

11.2.A.2

A closed electrical loop is a closed path through which charges may flow.

11.2.A.2.i

A closed circuit is one in which charges would be able to flow.

11.2.A.2.ii

An open circuit is one in which charges would not be able to flow.

11.2.A.2.iii

A short circuit is one in which charges would be able to flow with no change in potential difference.

11.2.A.3

A single circuit element may be part of multiple electrical loops.

11.2.A.4

Circuit schematics are representations used to describe and analyze electric circuits.

11.2.A.4.i

The properties of an electric circuit are dependent on the physical arrangement of its constituent elements.

continued on next page

LEARNING OBJECTIVE

11.2.A

Describe the behavior of a circuit.

ESSENTIAL KNOWLEDGE

11.2.A.4.ii

Circuit elements have common symbols that are used to create schematic diagrams. Variable elements are indicated by a diagonal strikethrough arrow across the standard symbol for that element.

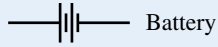

Battery



Bulb



Switch



Capacitor



Resistor



Ammeter



Voltmeter

BOUNDARY STATEMENT

Unless otherwise specified, all circuit schematic diagrams will be drawn using conventional current.

SUGGESTED SKILLS

1.B

Create quantitative graphs with appropriate scales and units, including plotting data.

2.B

Calculate or estimate an unknown quantity with units from known quantities, by selecting and following a logical computational pathway.

2.D

Predict new values or factors of change of physical quantities using functional dependence between variables.

3.A

Create experimental procedures that are appropriate for a given scientific question.

3.B

Apply an appropriate law, definition, theoretical relationship, or model to make a claim.

TOPIC 11.3

Resistance, Resistivity, and Ohm's Law

Required Course Content

LEARNING OBJECTIVE

11.3.A

Describe the resistance of an object using physical properties of that object.

11.3.B

Describe the electrical characteristics of elements of a circuit.

ESSENTIAL KNOWLEDGE

11.3.A.1

Resistance is a measure of the degree to which an object opposes the movement of electric charge.

11.3.A.2

The resistance of a resistor with uniform geometry is proportional to its resistivity and length and is inversely proportional to its cross-sectional area.

Relevant equation:

$$R = \frac{\rho \ell}{A}$$

11.3.A.2.i

Resistivity is a fundamental property of a material that depends on its atomic and molecular structure and quantifies how strongly the material opposes the motion of electric charge.

11.3.A.2.ii

The resistivity of a conductor typically increases with temperature.

11.3.B.1

Ohm's law relates current, resistance, and potential difference across a conductive element of a circuit.

Relevant equation:

$$I = \frac{\Delta V}{R}$$

continued on next page

LEARNING OBJECTIVE

11.3.B

Describe the electrical characteristics of elements of a circuit.

ESSENTIAL KNOWLEDGE

11.3.B.1.i

Materials that obey Ohm's law have constant resistance for all currents and are called ohmic materials.

11.3.B.1.ii

The resistivity of an ohmic material is constant regardless of temperature.

11.3.B.1.iii

Resistors can also convert electrical energy to thermal energy, which may change the temperature of both the resistor and the resistor's environment.

11.3.B.1.iv

The resistance of an ohmic circuit element can be determined from the slope of a graph of the current in the element as a function of the potential difference across the element.

SUGGESTED SKILLS

1.C

Create qualitative sketches of graphs that represent features of a model or the behavior of a physical system.

2.A

Derive a symbolic expression from known quantities by selecting and following a logical mathematical pathway.

2.D

Predict new values or factors of change of physical quantities using functional dependence between variables.

3.C

Justify or support a claim using evidence from experimental data, physical representations, or physical principles or laws.

TOPIC 11.4

Electric Power

Required Course Content

LEARNING OBJECTIVE

11.4.A

Describe the transfer of energy into, out of, or within an electric circuit, in terms of power.

ESSENTIAL KNOWLEDGE

11.4.A.1

The rate at which energy is transferred, converted, or dissipated by a circuit element depends on the current in the element and the electric potential difference across it.

Relevant equation:

$$P = I\Delta V$$

Derived equations:

$$P = I^2 R = \frac{(\Delta V)^2}{R}$$

11.4.A.2

The brightness of a bulb increases with power, so power can be used to qualitatively predict the brightness of bulbs in a circuit.

TOPIC 11.5

Compound Direct Current (DC) Circuits

Required Course Content

LEARNING OBJECTIVE

11.5.A

Describe the equivalent resistance of multiple resistors connected in a circuit.

ESSENTIAL KNOWLEDGE

11.5.A.1

Circuit elements may be connected in series and/or in parallel.

11.5.A.1.i

A series connection is one in which any charge passing through one circuit element must proceed through all elements in that connection and has no other path available. The current in each element in series must be the same.

11.5.A.1.ii

A parallel connection is one in which charges may flow through one of two or more paths. Across each path, the potential difference is the same.

11.5.A.2

A collection of resistors in a circuit may be analyzed as though it were a single resistor with an equivalent resistance R_{eq} .

11.5.A.2.i

The equivalent resistance of a set of resistors in series is the sum of the individual resistances.

Relevant equation:

$$R_{\text{eq},s} = \sum_i R_i$$

SUGGESTED SKILLS

1.A

Create diagrams, tables, charts, or schematics to represent physical situations.

2.A

Derive a symbolic expression from known quantities by selecting and following a logical mathematical pathway.

2.C

Compare physical quantities between two or more scenarios or at different times and locations in a single scenario.

3.B

Apply an appropriate law, definition, theoretical relationship, or model to make a claim.

continued on next page

LEARNING OBJECTIVE

11.5.A

Describe the equivalent resistance of multiple resistors connected in a circuit.

11.5.B

Describe a circuit with resistive wires and a battery with internal resistance.

ESSENTIAL KNOWLEDGE

11.5.A.2.ii

The inverse of the equivalent resistance of a set of resistors connected in parallel is equal to the sum of the inverses of the individual resistances.

Relevant equation:

$$\frac{1}{R_{\text{eq},p}} = \sum_i \frac{1}{R_i}$$

11.5.A.2.iii

When resistors are connected in parallel, the number of paths available to charges increases, and the equivalent resistance of the group of resistors decreases.

11.5.B.1

Ideal batteries have negligible internal resistance. Ideal wires have negligible resistance.

11.5.B.1.i

The resistance of wires that are good conductors may normally be neglected, because their resistance is much smaller than that of other elements of a circuit.

11.5.B.1.ii

The resistance of wires may only be neglected if the circuit contains other elements that do have resistance.

11.5.B.1.iii

The potential difference a battery would supply if it were ideal is the potential difference measured across the terminals when there is no current in the battery and is sometimes referred to as its emf (\mathcal{E}).

11.5.B.2

The internal resistance of a nonideal battery may be treated as the resistance of a resistor in series with an ideal battery and the remainder of the circuit.

11.5.B.3

When there is current in a nonideal battery with internal resistance r , the potential difference across the terminals of the battery is reduced relative to the potential difference when there is no current in the battery.

Derived equation:

$$\Delta V_{\text{terminal}} = \mathcal{E} - Ir$$

continued on next page

LEARNING OBJECTIVE**11.5.C**

Describe the measurement of current and potential difference in a circuit.

ESSENTIAL KNOWLEDGE**11.5.C.1**

Ammeters are used to measure current at a specific point in a circuit.

11.5.C.1.i

Ammeters must be connected in series with the element in which current is being measured.

11.5.C.1.ii

Ideal ammeters have zero resistance so that they do not affect the current in the element that they are in series with.

11.5.C.2

Voltmeters are used to measure electric potential difference between two points in a circuit.

11.5.C.2.i

Voltmeters must be connected in parallel with the element across which potential difference is being measured.

11.5.C.2.ii

Ideal voltmeters have an infinite resistance so that no charge flows through them.

11.5.C.3

Nonideal ammeters and voltmeters will change the properties of the circuit being measured.

BOUNDARY STATEMENT

AP Physics 2 only expects students to qualitatively discuss how a nonideal ammeter or voltmeter will affect the results of measurements. Unless otherwise stated, all batteries, wires, and meters are assumed to be ideal.

Circuits with batteries of different potential differences connected in parallel will not be assessed.

SUGGESTED SKILLS

1.C

Create qualitative sketches of graphs that represent features of a model or the behavior of a physical system.

2.A

Derive a symbolic expression from known quantities by selecting and following a logical mathematical pathway.

2.C

Compare physical quantities between two or more scenarios or at different times and locations in a single scenario.

3.B

Apply an appropriate law, definition, theoretical relationship, or model to make a claim.

TOPIC 11.6

Kirchhoff's Loop Rule

Required Course Content

LEARNING OBJECTIVE

11.6.A

Describe a circuit or elements of a circuit by applying Kirchhoff's loop rule.

ESSENTIAL KNOWLEDGE

11.6.A.1

Energy changes in simple electrical circuits may be represented in terms of charges moving through electric potential differences within circuit elements.

Relevant equation:

$$\Delta U_E = q\Delta V$$

11.6.A.2

Kirchhoff's loop rule is a consequence of the conservation of energy.

11.6.A.3

Kirchhoff's loop rule states that the sum of potential differences across all circuit elements in a single closed loop must equal zero.

Relevant equation:

$$\sum \Delta V = 0$$

11.6.A.4

The values of electric potential at points in a circuit can be represented by a graph of electric potential as a function of position within a loop.

TOPIC 11.7

Kirchhoff's Junction Rule

Required Course Content

LEARNING OBJECTIVE

11.7.A

Describe a circuit or elements of a circuit by applying Kirchhoff's junction rule.

ESSENTIAL KNOWLEDGE

11.7.A.1

Kirchhoff's junction rule is a consequence of the conservation of electric charge.

11.7.A.2

Kirchhoff's junction rule states that the total amount of charge entering a junction per unit time must equal the total amount of charge exiting that junction per unit time.

Relevant equation:

$$\sum I_{\text{in}} = \sum I_{\text{out}}$$

SUGGESTED SKILLS

1.A

Create diagrams, tables, charts, or schematics to represent physical situations.

2.B

Calculate or estimate an unknown quantity with units from known quantities, by selecting and following a logical computational pathway.

2.C

Compare physical quantities between two or more scenarios or at different times and locations in a single scenario.

3.C

Justify or support a claim using evidence from experimental data, physical representations, or physical principles or laws.

SUGGESTED SKILLS

1.B

Create quantitative graphs with appropriate scales and units, including plotting data.

1.C

Create qualitative sketches of graphs that represent features of a model or the behavior of a physical system.

2.A

Derive a symbolic expression from known quantities by selecting and following a logical mathematical pathway.

2.D

Predict new values or factors of change of physical quantities using functional dependence between variables.

3.A

Create experimental procedures that are appropriate for a given scientific question.

3.C

Justify or support a claim using evidence from experimental data, physical representations, or physical principles or laws.

TOPIC 11.8

Resistor-Capacitor (RC) Circuits

Required Course Content

LEARNING OBJECTIVE

11.8.A

Describe the equivalent capacitance of multiple capacitors.

ESSENTIAL KNOWLEDGE

11.8.A.1

A collection of capacitors in a circuit may be analyzed as though it were a single capacitor with an equivalent capacitance C_{eq} .

11.8.A.1.i

The inverse of the equivalent capacitance of a set of capacitors connected in series is equal to the sum of the inverses of the individual capacitances.

Relevant equation:

$$\frac{1}{C_{eq,s}} = \sum_i \frac{1}{C_i}$$

11.8.A.1.ii

The equivalent capacitance of a set of capacitors in series is less than the capacitance of the smallest capacitor.

11.8.A.1.iii

The equivalent capacitance of a set of capacitors in parallel is the sum of the individual capacitances.

Relevant equation:

$$C_{eq,p} = \sum_i C_i$$

11.8.A.2

As a result of conservation of charge, each of the capacitors in series must have the same magnitude of charge on each plate.

continued on next page

LEARNING OBJECTIVE**11.8.B**

Describe the behavior of a circuit containing combinations of resistors and capacitors.

ESSENTIAL KNOWLEDGE**11.8.B.1**

The time constant τ is a significant feature of an RC circuit.

11.8.B.1.i

The time constant of an RC circuit is a measure of how quickly the capacitor will charge or discharge and is defined as

$$\tau = R_{\text{eq}} C_{\text{eq}}$$

11.8.B.1.ii

For a charging capacitor, the time constant represents the time required for the capacitor's charge to increase from zero to approximately 63 percent of its final asymptotic value.

11.8.B.1.iii

For a discharging capacitor, the time constant represents the time required for the capacitor's charge to decrease from fully charged to approximately 37 percent of its initial value.

11.8.B.2

The potential difference across a capacitor and the current in the branch of the circuit containing the capacitor each change over time as the capacitor charges and discharges, but both will reach a steady state after a long time interval.

11.8.B.2.i

Immediately after being placed in a circuit, an uncharged capacitor acts like a wire, and charge can easily flow to or from the plates of the capacitor.

11.8.B.2.ii

As a capacitor charges, changes to the potential difference across the capacitor affect the charge on the plates of the capacitor, the current circuit branch in which the capacitor is located, and the electric potential energy stored in the capacitor.

11.8.B.2.iii

The potential difference across a capacitor, the current in the circuit branch in which the capacitor is located, and the electric potential energy stored in the capacitor all change with respect to time and asymptotically approach steady state conditions.

continued on next page

LEARNING OBJECTIVE

11.8.B

Describe the behavior of a circuit containing combinations of resistors and capacitors.

ESSENTIAL KNOWLEDGE

11.8.B.2.iv

After a long time, a charging capacitor approaches a state of being fully charged, reaching a maximum potential difference at which there is zero current in the circuit branch in which the capacitor is located.

11.8.B.2.v

Immediately after a charged capacitor begins discharging, the amount of charge on the capacitor plates and the energy stored in the capacitor begin to decrease.

11.8.B.2.vi

As a capacitor discharges, the amount of charge on the capacitor, the potential difference across the capacitor, and the current in the circuit branch in which the capacitor is located all decrease until a steady state is reached.

11.8.B.2.vii

After either charging or discharging for times much greater than the time constant, the capacitor and the relevant circuit branch may be modeled using steady-state conditions.

BOUNDARY STATEMENT

Descriptions of charging/discharging RC circuits in AP Physics 2 are limited to qualitative descriptions and representations. While students should be able to mathematically describe initial and final states of RC circuits, students are not expected to mathematically model these behaviors with respect to time.

AP PHYSICS 2

UNIT 12

Magnetism and Electromagnetism



12–15%
AP EXAM WEIGHTING



~10–14
CLASS PERIODS

The icon consists of the letters 'AP' in a bold, black, sans-serif font, centered within a white square. This square is itself centered within a larger white circle. The circle has a thin blue border. Below the square, there are two short, horizontal blue lines, suggesting a computer screen or a digital interface.

Remember to go to [AP Classroom](#) to assign students the online **Progress Check** for this unit.

Whether assigned as homework or completed in class, the **Progress Check** provides each student with immediate feedback related to this unit's topics and science practices.

Progress Check 12

Multiple-choice: ~18 questions

Free-response: 4 questions

- Mathematical Routines
- Translation Between Representations
- Experimental Design and Analysis
- Qualitative/Quantitative Translation

Magnetism and Electromagnetism



Developing Understanding

ESSENTIAL QUESTIONS

- How does an induction stovetop heat a pan without heating the cooktop?
- How would our world look different without induction?
- How would modern medicine be different without powerful magnets?
- Why is it dangerous to wear metal inside an MRI machine?
- How does an electric motor work?

In Unit 12, students will build upon their knowledge of electrostatic forces, fields, free charges, and circuits by exploring the relationships between moving charges, the magnetic fields they generate, and the magnetic forces that act on other moving charges in those fields. Students will discover the natural symmetry between electricity and magnetism and how electromagnetic induction powers technology in modern society. The concepts introduced in Unit 12 are greatly expanded upon in *AP Physics C: Electricity and Magnetism*.

Building the Science Practices

2.B 2.C 2.D 3.C

Mathematical representations are tools that physicists use to describe, explain, and solve physical phenomena and problems. To justify claims with evidence (3.C) about physical situations, students need a thorough understanding of mathematical representations. Students can practice using equations to analyze situations and explain why they are appropriate. For example, when analyzing the emf induced in a loop with a changing area, students can be asked to justify why they can simplify the equation

$$\mathcal{E} = -\frac{\Delta\Phi_B}{\Delta t} = -\frac{\Delta(BA\cos\theta)}{\Delta t} \text{ to } \mathcal{E} = -Blv$$

in some cases. Students can also practice using equations to calculate numerical values (2.B) and to predict how a quantity changes when another quantity varies (2.C, 2.D). As students improve their use of mathematical models, they will be able to connect and relate knowledge across different scales, concepts, and representations.

Preparing for the AP Exam

On both the multiple-choice and free-response sections of the AP Physics 2 Exam, students need to be able to describe the relationships between physical quantities in order to articulate the effects of changing the value of a specific quantity in a scenario. Therefore, students will benefit from opportunities to investigate changes in systems, including practicing using functional principles of physics to decide whether a quantity will increase, decrease, or remain the same when another quantity is changed. Additionally, when writing or identifying justifications for claims, simply referencing an equation, law, or physical principle is not sufficient. For example, stating that “the force on a charged particle is to the right because of the ‘right-hand rule’” is not a complete enough answer to earn points on the free-response section of the exam. Students should clearly and concisely explain the steps that lead from the equation, law or physical principle to the justification of their claim.

UNIT AT A GLANCE

Topic	Suggested Skills
12.1 Magnetic Fields	<p>1.A Create diagrams, tables, charts, or schematics to represent physical situations.</p> <p>2.C Compare physical quantities between two or more scenarios or at different times and locations in a single scenario.</p> <p>3.B Apply an appropriate law, definition, theoretical relationship, or model to make a claim.</p> <p>3.C Justify or support a claim using evidence from experimental data, physical representations, or physical principles or laws.</p>
12.2 Magnetism and Moving Charges	<p>1.A Create diagrams, tables, charts, or schematics to represent physical situations.</p> <p>2.A Derive a symbolic expression from known quantities by selecting and following a logical mathematical pathway.</p> <p>2.C Compare physical quantities between two or more scenarios or at different times and locations in a single scenario.</p> <p>3.B Apply an appropriate law, definition, theoretical relationship, or model to make a claim.</p>
12.3 Magnetism and Current-Carrying Wires	<p>1.B Create quantitative graphs with appropriate scales and units, including plotting data.</p> <p>2.A Derive a symbolic expression from known quantities by selecting and following a logical mathematical pathway.</p> <p>2.D Predict new values or factors of change of physical quantities using functional dependence between variables.</p> <p>3.A Create experimental procedures that are appropriate for a given scientific question.</p> <p>3.C Justify or support a claim using evidence from experimental data, physical representations, or physical principles or laws.</p>
12.4 Electromagnetic Induction and Faraday's Law	<p>1.C Create qualitative sketches of graphs that represent features of a model or the behavior of a physical system.</p> <p>2.B Calculate or estimate an unknown quantity with units from known quantities, by selecting and following a logical computational pathway.</p> <p>2.D Predict new values or factors of change of physical quantities using functional dependence between variables.</p> <p>3.C Justify or support a claim using evidence from experimental data, physical representations, or physical principles or laws.</p>



Go to [AP Classroom](#) to assign the **Progress Check** for Unit 12.
Review the results in class to identify and address any student misunderstandings.

SAMPLE INSTRUCTIONAL ACTIVITIES

The sample activities on this page are optional and are offered to provide possible ways to incorporate instructional approaches into the classroom. Teachers do not need to use these activities or instructional approaches and are free to alter or edit them. The examples below were developed in partnership with teachers from the AP community to share ways that they approach teaching some of the topics in this unit. Please refer to the Instructional Approaches section beginning on p. 167 for more examples of activities and strategies.

Activity	Topic	Sample Activity
1	12.2	Model Questions/Friends without Pens On AP Central, locate “ AP Physics 2 Featured Question: Charged Particle in a Magnetic Field ” and have students work through it in small groups.
2	12.2	Discussion Groups Have students create right-hand-rule questions and then trade with other students and answer them. Examples: give charge sign, velocity, and magnetic force directions and determine the magnetic field direction; give velocity, force, and magnetic field directions and determine the charge sign; give velocity and magnetic field directions and determine the direction of an electric field that would cause balanced forces.
3	12.2	Graph and Switch Ask each student to come up with two related values in a magnetism-focused situation. (Examples: “Radius vs. speed of a circling charge in a magnetic field” or “flux through a spinning coil in a uniform magnetic field as a function of time”.) Then have students switch papers. The students must then sketch the graph of the situation given to them and justify either qualitatively or quantitatively using functional dependence.
4	12.3	Discussion Groups Show students a “Non-Contact Voltage Tester” and hold it up to a wire carrying AC current (it chirps). Hold it to a battery-powered circuit carrying DC current (no chirp). Have students discuss how this object could use magnetism and Faraday’s Law principles to detect AC but not DC current.
5	12.3	Desktop Experiment Tasks Break students into groups of 3-4 students. Give students a battery, three light bulbs, wire, and a cheap compass. Ask students to develop an experiment that shows evidence that magnetic field strength decreases with distance from the wire, and other experiment that shows evidence that magnetic field increases with current in the wire.

SUGGESTED SKILLS

1.A

Create diagrams, tables, charts, or schematics to represent physical situations.

2.C

Compare physical quantities between two or more scenarios or at different times and locations in a single scenario.

3.B

Apply an appropriate law, definition, theoretical relationship, or model to make a claim.

3.C

Justify or support a claim using evidence from experimental data, physical representations, or physical principles or laws.

TOPIC 12.1

Magnetic Fields

Required Course Content

LEARNING OBJECTIVE

12.1.A

Describe the properties of a magnetic field.

12.1.B

Describe the magnetic behavior of a material as a result of the configuration of magnetic dipoles in the material.

ESSENTIAL KNOWLEDGE

12.1.A.1

A magnetic field is a vector field that can be used to determine the magnetic force exerted on moving electric charges, electric currents, or magnetic materials.

12.1.A.1.i

Magnetic fields can be produced by magnetic dipoles or combinations of dipoles, but never by monopoles.

12.1.A.1.ii

Magnetic dipoles have north and south polarity.

12.1.A.2

A magnetic field is a vector quantity and can be represented using vector field maps.

12.1.A.2.i

Magnetic field lines form closed loops.

12.1.A.2.ii

Magnetic fields in a bar magnet form closed loops, with the external magnetic field pointing away from one end (defined as the north pole) and returning to the other end (defined as the south pole).

12.1.B.1

Magnetic dipoles result from the circular or rotational motion of electric charges. In magnetic materials, this can be the motion of electrons.

12.1.B.1.i

Permanent magnetism and induced magnetism are system properties that both result from the alignment of magnetic dipoles within a system.

LEARNING OBJECTIVE**12.1.B**

Describe the magnetic behavior of a material as a result of the configuration of magnetic dipoles in the material.

ESSENTIAL KNOWLEDGE**12.1.B.1.ii**

No magnetic north pole is ever found in isolation from a south pole. For example, if a bar magnet is broken in half, both halves are magnetic dipoles.

12.1.B.1.iii

Magnetic poles of the same polarity will repel; magnetic poles of opposite polarity will attract.

12.1.B.1.iv

The magnitude of the magnetic field from a magnetic dipole decreases with increasing distance from the dipole.

12.1.B.2

A magnetic dipole, such as a magnetic compass, placed in a magnetic field will tend to align with the magnetic field.

12.1.B.3

A material's composition influences its magnetic behavior in the presence of an external magnetic field.

12.1.B.3.i

Ferromagnetic materials such as iron, nickel, and cobalt can be permanently magnetized by an external field that causes the alignment of magnetic domains or atomic magnetic dipoles.

12.1.B.3.ii

Paramagnetic materials such as aluminum, titanium, and magnesium interact weakly with an external magnetic field, in that the magnetic dipoles of the material do not remain aligned after the external field is removed.

12.1.B.3.iii

All materials have the property of diamagnetism, in that their electronic structure creates a usually weak alignment of the dipole moments of the material opposite the external magnetic field.

12.1.B.4

Earth's magnetic field may be approximated as a magnetic dipole.

continued on next page

LEARNING OBJECTIVE**12.1.C**

Describe the magnetic permeability of a material.

ESSENTIAL KNOWLEDGE**12.1.C.1**

Magnetic permeability is a measurement of the amount of magnetization in a material in response to an external magnetic field.

12.1.C.2

Free space has a constant value of magnetic permeability, known as the vacuum permeability μ_0 , that appears in equations representing physical relationships.

12.1.C.3

The permeability of matter has values different from that of free space and arises from the matter's composition and arrangement. It is not a constant for a material and varies based on many factors, including temperature, orientation, and strength of the external field.

TOPIC 12.2

Magnetism and
Moving Charges

Required Course Content

LEARNING OBJECTIVE

12.2.A

Describe the magnetic field produced by moving charged objects.

12.2.B

Describe the force exerted on moving charged objects by a magnetic field.

ESSENTIAL KNOWLEDGE

12.2.A.1

A single moving charged object produces a magnetic field.

12.2.A.1.i

The magnetic field at a particular point produced by a moving charged object depends on the object's velocity and the distance between the point and the object.

12.2.A.1.ii

At a point in space, the direction of the magnetic field produced by a moving charged object is perpendicular to both the velocity of the object and the position vector from the object to that point in space and can be determined using the right-hand rule.

12.2.A.1.iii

The magnitude of the magnetic field is a maximum when the velocity vector and the position vector from the object to that point in space are perpendicular.

12.2.B.1

Magnetic forces describe interactions between moving charged objects.

12.2.B.2

A magnetic field may exert a force on a charged object moving in that field.

SUGGESTED SKILLS

1.A

Create diagrams, tables, charts, or schematics to represent physical situations.

2.A

Derive a symbolic expression from known quantities by selecting and following a logical mathematical pathway.

2.C

Compare physical quantities between two or more scenarios or at different times and locations in a single scenario.

3.B

Apply an appropriate law, definition, theoretical relationship, or model to make a claim.

continued on next page

LEARNING OBJECTIVE

12.2.B

Describe the force exerted on moving charged objects by a magnetic field.

ESSENTIAL KNOWLEDGE

12.2.B.2.i

The magnitude of the force exerted by a magnetic field on a moving charged object is proportional to the magnitude of the charge, the magnitude of the charged object's velocity, and the magnitude of the magnetic field and also depends on the angle between the velocity and magnetic field vectors.

Relevant equation:

$$F_B = qvB \sin \theta$$

12.2.B.2.ii

The direction of the force exerted by a magnetic field on a moving charged object is perpendicular to both the direction of the magnetic field and the velocity of the charge, as defined by the right-hand rule.

12.2.B.3

In a region containing both a magnetic field and an electric field, a moving charged object will experience independent forces from each field.

12.2.B.4

The Hall effect describes the potential difference created in a conductor by an external magnetic field that has a component perpendicular to the direction of charges moving in the conductor.

BOUNDARY STATEMENT

Quantitative treatment of the magnitude of the magnetic force exerted by a magnetic field on a moving charge is limited to angles of 0, 90, and 180 degrees between the velocity and the magnetic field. Qualitative analysis of other angles is permitted.

TOPIC 12.3

Magnetism and
Current-Carrying Wires

Required Course Content

LEARNING OBJECTIVE

12.3.A

Describe the magnetic field produced by a current-carrying wire.

ESSENTIAL KNOWLEDGE

12.3.A.1

A current-carrying wire produces a magnetic field.

12.3.A.1.i

The magnetic field vectors around a long, straight, current-carrying wire are tangent to concentric circles centered on that wire. The field has no component toward, away from, or parallel to the long, straight, current-carrying wire.

12.3.A.1.ii

At a point in space, the magnitude of the magnetic field due to a long, straight, current-carrying wire is proportional to the magnitude of the current in the wire and inversely proportional to the perpendicular distance from the central axis of the wire to the point.

Relevant equation:

$$B = \frac{\mu_0 I}{2\pi r}$$

12.3.A.1.iii

The direction of the magnetic field created by a current-carrying wire is determined with the right-hand rule.

12.3.A.1.iv

The direction of the magnetic field at the center of a current-carrying loop is directed along the axis of the loop and can be found using the right-hand rule.

12.3.A.1.v

The magnetic field at a location near two or more current-carrying wires can be determined using vector addition principles.

SUGGESTED SKILLS

1.B

Create quantitative graphs with appropriate scales and units, including plotting data.

2.A

Derive a symbolic expression from known quantities by selecting and following a logical mathematical pathway.

2.D

Predict new values or factors of change of physical quantities using functional dependence between variables.

3.A

Create experimental procedures that are appropriate for a given scientific question.

3.C

Justify or support a claim using evidence from experimental data, physical representations, or physical principles or laws.

continued on next page

LEARNING OBJECTIVE**12.3.B**

Describe the force exerted on a current-carrying wire by a magnetic field.

ESSENTIAL KNOWLEDGE**12.3.B.1**

A magnetic field may exert a force on a current-carrying wire.

12.3.B.1.i

The magnitude of the force exerted by a magnetic field on a current-carrying wire is proportional to the current, the length of the portion of the wire within the magnetic field, and the magnitude of the magnetic field, and also depends on the angle between the direction of the current in the wire and the direction of the magnetic field.

Relevant equation:

$$F_B = I\ell B \sin \theta$$

12.3.B.1.ii

The direction of the force exerted by the magnetic field on a current-carrying wire is determined by the right-hand rule.

TOPIC 12.4

Electromagnetic Induction and Faraday's Law

Required Course Content

LEARNING OBJECTIVE

12.4.A

Describe the induced electric potential difference resulting from a change in magnetic flux.

ESSENTIAL KNOWLEDGE

12.4.A.1

Magnetic flux is a description of the amount of the component of a magnetic field that is perpendicular to a cross-sectional area.

12.4.A.2

Magnetic flux through a surface is proportional to the magnitude of the component of the magnetic field perpendicular to the surface and to the cross-sectional area of the surface.

Relevant equation:

$$\Phi_B = BA \cos \theta$$

12.4.A.2.i

The area vector is defined to be perpendicular to the plane of the surface and directed outward from a closed surface.

12.4.A.2.ii

The sign of the magnetic flux indicates whether the magnetic field is parallel to or antiparallel to the area vector.

12.4.A.3

Faraday's law describes the relationship between changing magnetic flux and the resulting induced emf in a system.

Relevant equation:

$$|\mathcal{E}| = \left| \frac{\Delta \Phi_B}{\Delta t} \right|$$

SUGGESTED SKILLS

1.C

Create qualitative sketches of graphs that represent features of a model or the behavior of a physical system.

2.B

Calculate or estimate an unknown quantity with units from known quantities, by selecting and following a logical computational pathway.

2.D

Predict new values or factors of change of physical quantities using functional dependence between variables.

3.C

Justify or support a claim using evidence from experimental data, physical representations, or physical principles or laws.

continued on next page

LEARNING OBJECTIVE

12.4.A

Describe the induced electric potential difference resulting from a change in magnetic flux.

ESSENTIAL KNOWLEDGE

12.4.A.4

Lenz's law is used to determine the direction of an induced emf resulting from a changing magnetic flux.

Relevant equation:

$$\mathcal{E} = -\frac{\Delta\Phi_B}{\Delta t} = -\frac{\Delta(BA\cos\theta)}{\Delta t}$$

12.4.A.4.i

An induced emf generates a current that creates a magnetic field that opposes the change in magnetic flux.

12.4.A.4.ii

The right-hand rule is used to determine the relationships between current, emf, and magnetic flux.

12.4.A.5

A common example of electromagnetic induction is a conducting rod on conducting rails in a region with a uniform magnetic field.

Derived equation:

$$\mathcal{E} = B\ell v$$

AP PHYSICS 2

UNIT 13

Geometric Optics



12–15%
AP EXAM WEIGHTING



~8–12
CLASS PERIODS

The icon consists of the letters 'AP' in a bold, black, sans-serif font, centered within a white square. This square is itself centered within a larger white circle. The circle has a thin blue border and a subtle drop shadow, giving it a three-dimensional appearance as if it's floating above the page.

Remember to go to [AP Classroom](#) to assign students the online **Progress Check** for this unit.

Whether assigned as homework or completed in class, the **Progress Check** provides each student with immediate feedback related to this unit's topic and science practices.

Progress Check 13

Multiple-choice: ~18 questions

Free-response: 4 questions

- Mathematical Routines
- Translation Between Representations
- Experimental Design and Analysis
- Qualitative/Quantitative Translation

Geometric Optics



Developing Understanding

ESSENTIAL QUESTIONS

- Why can't a flat lens focus light?
- Why does a mirror flip words?
- How can we make things invisible?
- Why does a straw in a glass of water look bent?

Unit 13 demonstrates another distinct shift in both content and the models used to analyze physical scenarios. In this unit, students will be introduced to the different ways of thinking about and modeling light. This unit will focus on using the ray model of light to determine the images formed by mirrors as a result of reflection and the images formed by lenses as a result of refraction. Students will be challenged to confront their misconceptions about light, including why objects are not always located where they are seen. In Unit 14, students will continue to explore the behavior of light as an electromagnetic wave and examine additional ways of thinking about and modeling light.

Building the Science Practices

1.B 2.B 2.D 3.A

Inquiry learning and critical thinking and problem-solving skills are best developed when scientific inquiry experiences are designed and implemented with increasing student involvement. In Unit 13, students can be asked to practice collecting data and determining appropriate experimental procedures to answer scientific questions (3.A). For example, students can be asked to analyze a familiar experiment by providing a written explanation of how they would make observations or collect data in the given scenario.

Once students have designed a procedure and have collected data, they can practice analyzing that data (1.B, 2.B, 2.D) by plotting linearized graphs and using the best fit line to the plotted data to make claims about the physical scenario.

Preparing for the AP Exam

The third free-response question on the AP Physics 2 Exam is the Experimental Design and Analysis (LAB) question. In this question, students will need to justify their selection of the kind of data needed and then design a plan to collect these data. Because students often struggle with knowing where to start when designing an experiment, they will benefit from scaffolded opportunities to determine the data needed to answer a scientific question. In the Experimental Design question on the exam, students will also be asked to linearize and analyze data. Practicing designing experiments, performing data analysis, and discussing sources of error throughout the course can help students prepare for and be successful on the Experimental Design and Analysis (LAB) question.

UNIT AT A GLANCE

Topic	Suggested Skills
13.1 Reflection	<p>1.A Create diagrams, tables, charts, or schematics to represent physical situations.</p> <p>2.B Calculate or estimate an unknown quantity with units from known quantities, by selecting and following a logical computational pathway.</p> <p>2.C Compare physical quantities between two or more scenarios or at different times and locations in a single scenario.</p> <p>3.B Apply an appropriate law, definition, theoretical relationship, or model to make a claim.</p>
13.2 Images Formed by Mirrors	<p>1.A Create diagrams, tables, charts, or schematics to represent physical situations.</p> <p>2.A Derive a symbolic expression from known quantities by selecting and following a logical mathematical pathway.</p> <p>2.C Compare physical quantities between two or more scenarios or at different times and locations in a single scenario.</p> <p>3.C Justify or support a claim using evidence from experimental data, physical representations, or physical principles or laws.</p>
13.3 Refraction	<p>1.B Create quantitative graphs with appropriate scales and units, including plotting data.</p> <p>2.B Calculate or estimate an unknown quantity with units from known quantities, by selecting and following a logical computational pathway.</p> <p>2.D Predict new values or factors of change of physical quantities using functional dependence between variables.</p> <p>3.A Create experimental procedures that are appropriate for a given scientific question.</p> <p>3.B Apply an appropriate law, definition, theoretical relationship, or model to make a claim.</p>
13.4 Images Formed by Lenses	<p>1.C Create qualitative sketches of graphs that represent features of a model or the behavior of a physical system.</p> <p>2.B Calculate or estimate an unknown quantity with units from known quantities, by selecting and following a logical computational pathway.</p> <p>2.D Predict new values or factors of change of physical quantities using functional dependence between variables.</p> <p>3.A Create experimental procedures that are appropriate for a given scientific question.</p> <p>3.B Apply an appropriate law, definition, theoretical relationship, or model to make a claim.</p>



Go to [AP Classroom](#) to assign the **Progress Check** for Unit 13.
Review the results in class to identify and address any student misunderstandings.

SAMPLE INSTRUCTIONAL ACTIVITIES

The sample activities on this page are optional and are offered to provide possible ways to incorporate instructional approaches into the classroom. Teachers do not need to use these activities or instructional approaches and are free to alter or edit them. The examples below were developed in partnership with teachers from the AP community to share ways that they approach teaching some of the topics in this unit. Please refer to the Instructional Approaches section beginning on p. 167 for more examples of activities and strategies.

Activity	Topic	Sample Activity
1	13.3	<p>Desktop Experiment Tasks</p> <p>Break students into groups of 3-4 students. Give each group orange gelatin dessert in a rectangular prism shaped container made of thin material. Give students a red laser, a protractor, and paper, and have them determine the index of refraction of the orange gelatin dessert without touching it directly. Have students practice writing experimental procedures by writing up their experiment.</p>
2	13.3	<p>Desktop Experiment Tasks</p> <p>Break students into groups of 3-4 students. Give each group a plastic hemispherical dish containing water, three pins and a sheet of graph paper. Then have students use the equipment to write and follow a procedure to determine the speed of light in water. Have the groups present their procedure to the class.</p>
3	13.4	<p>Desktop Experiment Tasks</p> <p>Break students into groups of 3-4 students. Provide each group with a magnifying glass and a source of light (light bulb, candle, etc.). Have each group design an experiment to determine the focal length of the magnifying glass by collecting data that could be graphed where the focal length of the magnifying glass can be determined from a feature of the graph. Take several pairs of object and image distance data, and graph them to find the focal length of the magnifying glass.</p>
4	13.4	<p>Working Backward</p> <p>Break students into groups of 2. Have student A describe a situation with a lens/mirror where the image is real/virtual and larger/smaller than the object (so, eight possibilities). Then, have student B determine whether the instrument is converging/diverging and where to put the object (closer than f, between f and $2f$ or beyond $2f$) to satisfy student A's parameters and draws a ray diagram to support the answer.</p>
5	13.4	<p>Quickwrite</p> <p>Explain to students how the human eye works. A normal human eye, without deficiencies, will focus the image of a distant object on the retina. If the object is closer, the eye muscles make the eye lens thicker so that the image still focuses on the retina. The closer the object, the more the eye muscles force the eye lens to be thicker. Ask students to explain what is happening in terms of s_o, s_i, and f, using equations to support the explanation of how the eye works.</p>

SUGGESTED SKILLS

1.A

Create diagrams, tables, charts, or schematics to represent physical situations.

2.B

Calculate or estimate an unknown quantity with units from known quantities, by selecting and following a logical computational pathway.

2.C

Compare physical quantities between two or more scenarios or at different times and locations in a single scenario.

3.B

Apply an appropriate law, definition, theoretical relationship, or model to make a claim.

TOPIC 13.1

Reflection

Required Course Content

LEARNING OBJECTIVE

13.1.A

Describe light as a ray.

13.1.B

Describe the reflection of light from a surface.

ESSENTIAL KNOWLEDGE

13.1.A.1

A light ray is a straight line that is perpendicular to the wavefront of a light wave and points in the direction of travel of the wave.

13.1.A.1.i

Light rays can be used to determine the behavior of light in geometric optics, where the wave nature of light can be neglected.

13.1.A.1.ii

Rays are not sufficient to understand the spreading of light. In interference and diffraction, the wave nature of the light is important.

13.1.A.1.iii

A laser is a common source of a single coherent, monochromatic beam of light that can be modeled as a ray. The wave nature of lasers will be considered in Unit 14.

13.1.A.2

Ray diagrams depict the path of light before and after an interaction with matter.

13.1.B.1

Light that is incident on a surface can be reflected.

continued on next page

LEARNING OBJECTIVE

13.1.B

Describe the reflection of light from a surface.

ESSENTIAL KNOWLEDGE

13.1.B.2

The law of reflection states that the angle between the incident ray and the normal (the line perpendicular to the surface) is equal to the angle between the reflected ray and the normal.

Relevant equation:

$$\theta_i = \theta_r$$

13.1.B.3

Diffuse reflection is the reflection of light from a rough surface and results in light reflected in many different directions, because the line normal to the surface varies over the area over which the light is incident.

13.1.B.4

Specular reflection is the reflection of light from a smooth surface and results in light uniformly reflected from the surface, because the line normal to the surface has an approximately constant direction over the area the light strikes.

SUGGESTED SKILLS

1.A

Create diagrams, tables, charts, or schematics to represent physical situations.

2.A

Derive a symbolic expression from known quantities by selecting and following a logical mathematical pathway.

2.C

Compare physical quantities between two or more scenarios or at different times and locations in a single scenario.

3.C

Justify or support a claim using evidence from experimental data, physical representations, or physical principles or laws.

TOPIC 13.2

Images Formed by Mirrors

Required Course Content

LEARNING OBJECTIVE

13.2.A

Describe the image formed by a mirror.

ESSENTIAL KNOWLEDGE

13.2.A.1

Incident light rays parallel to the principal axis of a concave (converging) mirror will be reflected toward a common location, called the focal point.

13.2.A.2

Incident light rays parallel to the principal axis of a convex (diverging) mirror will be reflected such that they appear to have originated from a common location behind the mirror, called the focal point.

13.2.A.3

The focal point of a plane mirror is an infinite distance from the mirror.

13.2.A.4

The focal point of a spherical mirror may be approximated as a point located on the principal axis of the mirror halfway between the surface of the mirror and the center of the mirror's radius of curvature.

13.2.A.5

A real image is formed by a mirror when light rays emanating from a common point are reflected and then intersect at a common point.

13.2.A.6

A virtual image is formed by a mirror when reflected light rays diverge such that they appear to have originated from a common point.

continued on next page

LEARNING OBJECTIVE

13.2.A

Describe the image formed by a mirror.

ESSENTIAL KNOWLEDGE

13.2.A.7

The location of an image depends on the focal length of the mirror and the distance between the object and the surface of the mirror.

Relevant equation:

$$\frac{1}{s_i} + \frac{1}{s_o} = \frac{1}{f}$$

13.2.A.7.i

The locations of a mirror's focal point, an object near the mirror, and the image of the object formed by the mirror follow sign conventions that are used to determine those locations relative to the mirror itself.

13.2.A.7.ii

The distance between the image formed and a plane mirror is equal to the distance between the object and the plane mirror.

13.2.A.8

The magnification of an image formed by a mirror is the ratio of the size of the image produced to the size of the object itself and depends on the locations of the object and image relative to the mirror.

Relevant equation:

$$|M| = \left| \frac{h_i}{h_o} \right| = \left| \frac{s_i}{s_o} \right|$$

13.2.A.9

Ray diagrams can be used to determine the location, type, size, and orientation of images formed by mirrors.

13.2.A.9.i

The three principal rays are typically used to find the images formed by mirrors. The principal rays are 1) the ray parallel to the principal axis, 2) the ray that reflects at the center of the mirror where the principal axis intersects the mirror, and 3) the ray that passes through the focal point of the mirror.

13.2.A.9.ii

Images formed by a mirror can be upright or inverted, virtual or real, and reduced, enlarged, or the same size as the object.

BOUNDARY STATEMENT

AP Physics 2 limits the study of mirrors to plane mirrors, convex spherical mirrors, and concave spherical mirrors.

SUGGESTED SKILLS

1.B

Create quantitative graphs with appropriate scales and units, including plotting data.

2.B

Calculate or estimate an unknown quantity with units from known quantities, by selecting and following a logical computational pathway.

2.D

Predict new values or factors of change of physical quantities using functional dependence between variables.

3.A

Create experimental procedures that are appropriate for a given scientific question.

3.B

Apply an appropriate law, definition, theoretical relationship, or model to make a claim.

TOPIC 13.3

Refraction

Required Course Content

LEARNING OBJECTIVE

13.3.A

Describe the refraction of light between two media.

ESSENTIAL KNOWLEDGE

13.3.A.1

Refraction is the change in direction of a light ray as the ray passes from one medium into another.

13.3.A.2

Refraction is a result of the speed of light changing when light enters a new medium.

13.3.A.3

The index of refraction of a given medium is inversely proportional to the speed of light in the medium.

Relevant equation:

$$n = \frac{c}{v}$$

13.3.A.4

Snell's law relates the angles of incidence and refraction of a light ray passing from one medium into another to the indices of refraction of the two media.

Relevant equation:

$$n_1 \sin \theta_1 = n_2 \sin \theta_2$$

13.3.A.4.i

When a light ray travels from a medium with a higher index of refraction into a medium with a lower index of refraction, the ray refracts away from the normal.

13.3.A.4.ii

When a light ray travels from a medium with a lower index of refraction into a medium with a higher index of refraction, the ray refracts toward the normal.

continued on next page

LEARNING OBJECTIVE**13.3.A**

Describe the refraction of light between two media.

ESSENTIAL KNOWLEDGE**13.3.A.4.iii**

When a light ray is incident along the normal to a surface, the transmitted ray is not refracted.

13.3.A.5

Total internal reflection may occur when light passes from one medium into another medium with a lower index of refraction.

13.3.A.5.i

Total internal reflection of light occurs beyond a critical angle of incidence.

Derived equation:

$$\theta_{\text{critical}} = \sin^{-1}\left(\frac{n_2}{n_1}\right)$$

13.3.A.5.ii

For incident rays at the critical angle, the ray refracts at 90 degrees and travels along the surface of the material.

13.3.A.5.iii

For incident rays beyond the critical angle, all light is reflected (no light is transmitted into the other medium).

SUGGESTED SKILLS

1.C

Create qualitative sketches of graphs that represent features of a model or the behavior of a physical system.

2.B

Calculate or estimate an unknown quantity with units from known quantities, by selecting and following a logical computational pathway.

2.D

Predict new values or factors of change of physical quantities using functional dependence between variables.

3.A

Create experimental procedures that are appropriate for a given scientific question.

3.B

Apply an appropriate law, definition, theoretical relationship, or model to make a claim.

TOPIC 13.4

Images Formed by Lenses

Required Course Content

LEARNING OBJECTIVE

13.4.A

Describe the image formed by a lens.

ESSENTIAL KNOWLEDGE

13.4.A.1

Incident light rays parallel to the principal axis of a thin convex (converging) lens will be refracted and converge toward a common location on the transmitted side of the lens, called the focal point.

13.4.A.2

Incident light rays parallel to the principal axis of a thin concave (diverging) lens will be refracted and diverge as if they originated from a focal point on the incident side of the lens.

13.4.A.3

A real image is formed by a lens when light rays originating from a common point are refracted such that they intersect at another common point.

13.4.A.4

A virtual image is formed by a lens when refracted light rays diverge such that they appear to have originated from a common point.

13.4.A.5

For a thin lens, the location of an image depends on the focal length of the lens and the distance between the object and the midline of the lens, as given by the thin-lens equation:

$$\frac{1}{s_i} + \frac{1}{s_o} = \frac{1}{f}.$$

continued on next page

LEARNING OBJECTIVE

13.4.A

Describe the image formed by a lens.

ESSENTIAL KNOWLEDGE

13.4.A.5.i

The locations of a lens's focal point, an object, and the image of the object formed by the lens follow sign conventions that are used to determine those locations relative to the lens itself.

13.4.A.5.ii

Lenses have a focal point on both sides of the lens that depends on the shape of the respective side of the lens.

13.4.A.6

For a thin lens, the magnification of an image is the ratio of the size of the image produced to the size of the object itself and depends on the locations of the object and image relative to the lens.

Relevant equation:

$$|M| = \left| \frac{h_i}{h_o} \right| = \left| \frac{s_i}{s_o} \right|$$

13.4.A.7

Ray diagrams can be used to determine the location, type, size, and orientation of images formed by lenses.

13.4.A.7.i

The three principal rays are typically used to find the images formed by lenses. The principal rays are 1) the ray parallel to the principal axis, 2) the ray that passes through the center of the lens where the principal axis intersects the lens, and 3) the ray that passes through the focal point of the lens.

13.4.A.7.ii

Images formed by a lens can be upright or inverted, virtual or real, and reduced, enlarged, or the same size as the object.

THIS PAGE IS INTENTIONALLY LEFT BLANK.

AP PHYSICS 2

UNIT 14

Waves, Sound, and Physical Optics



12–15%
AP EXAM WEIGHTING



~14–23
CLASS PERIODS



Remember to go to [AP Classroom](#) to assign students the online **Progress Check** for this unit.

Whether assigned as homework or completed in class, the **Progress Check** provides each student with immediate feedback related to this unit's topic and science practices.

Progress Check 14

Multiple-choice: ~30 questions

Free-response: 4 questions

- Mathematical Routines
- Translation Between Representations
- Experimental Design and Analysis
- Qualitative/Quantitative Translation

Waves, Sound, and Physical Optics



Developing Understanding

ESSENTIAL QUESTIONS

- Why does an ambulance siren sound different when it is moving toward you than when it is moving away from you?
- Why does it look like a rainbow when you see a puddle of water with oil in it at a gas station?
- Why do two notes an octave apart sound the same?
- Why can you hear a person around a corner, but you can't see them?
- What makes a sonic boom?

In Unit 14, students will investigate the behavior of waves, including a focused look at sound waves. The study of waves includes ways to quantify a wave, such as amplitude, wavelength, period, frequency, and wave speed, and how light can be modeled as a wave. This unit will also address the concepts of diffraction and interference, polarization, the Doppler effect, and thin-film interference. The end of Unit 14 leaves an open question of whether light should be considered a wave or a particle, which will be further studied in Unit 15.

Building the Science Practices

2.A 2.C 2.D 3.B

In Unit 14, students will be introduced to new, but somewhat familiar, equations—and be asked to derive new expressions from those equations (**2.A**), just as they have in previous units. Those new expressions can help students compare physical quantities between scenarios (**2.C**), to make claims (**3.B**), and justify claims or predict values of variables using functional dependence (**2.D**). For example, students might be asked to determine the new distance between bright fringes of a diffraction pattern if the frequency of the light through the single slit is doubled. Because using functional dependence to predict changes in quantities can be challenging, students may benefit from many opportunities practice these important mathematical skills.

Preparing for the AP Exam

Creating models and representations is a fundamental piece of the second question in the free-response section—the Translation Between Representations (TBR) question—and the analysis of models and representations constitutes a large part of the multiple-choice section of the AP Physics 2 Exam. Physicists often use models and representations to show the behavior of objects and/or systems of objects and to illustrate physics concepts. Representations and models include, but are not limited to, sketches of the physical situation, graphs, mathematical equations and verbal descriptions. As they encounter new scenarios through the unit, students should be encouraged to apply different representations based on the type of information given.

UNIT AT A GLANCE

Topic	Suggested Skills
14.1 Properties of Wave Pulses and Waves	<p>1.C Create qualitative sketches of graphs that represent features of a model or the behavior of a physical system.</p> <p>2.C Compare physical quantities between two or more scenarios or at different times and locations in a single scenario.</p> <p>3.B Apply an appropriate law, definition, theoretical relationship, or model to make a claim.</p> <p>3.C Justify or support a claim using evidence from experimental data, physical representations, or physical principles or laws.</p>
14.2 Periodic Waves	<p>1.A Create diagrams, tables, charts, or schematics to represent physical situations.</p> <p>2.C Compare physical quantities between two or more scenarios or at different times and locations in a single scenario.</p> <p>3.B Apply an appropriate law, definition, theoretical relationship, or model to make a claim.</p> <p>3.C Justify or support a claim using evidence from experimental data, physical representations, or physical principles or laws.</p>
14.3 Boundary Behavior of Waves and Polarization	<p>1.A Create diagrams, tables, charts, or schematics to represent physical situations.</p> <p>2.C Compare physical quantities between two or more scenarios or at different times and locations in a single scenario.</p> <p>3.B Apply an appropriate law, definition, theoretical relationship, or model to make a claim.</p> <p>3.C Justify or support a claim using evidence from experimental data, physical representations, or physical principles or laws.</p>
14.4 Electromagnetic Waves	<p>1.A Create diagrams, tables, charts, or schematics to represent physical situations.</p> <p>2.C Compare physical quantities between two or more scenarios or at different times and locations in a single scenario.</p> <p>3.B Apply an appropriate law, definition, theoretical relationship, or model to make a claim.</p> <p>3.C Justify or support a claim using evidence from experimental data, physical representations, or physical principles or laws.</p>

continued on next page

UNIT AT A GLANCE *(cont'd)*

Topic	Suggested Skills
14.5 The Doppler Effect	<p>1.A Create diagrams, tables, charts, or schematics to represent physical situations.</p> <p>2.C Compare physical quantities between two or more scenarios or at different times and locations in a single scenario.</p> <p>3.B Apply an appropriate law, definition, theoretical relationship, or model to make a claim.</p> <p>3.C Justify or support a claim using evidence from experimental data, physical representations, or physical principles or laws.</p>
14.6 Wave Interference and Standing Waves	<p>1.B Create quantitative graphs with appropriate scales and units, including plotting data.</p> <p>1.C Create qualitative sketches of graphs that represent features of a model or the behavior of a physical system.</p> <p>2.A Derive a symbolic expression from known quantities by selecting and following a logical mathematical pathway.</p> <p>2.D Predict new values or factors of change of physical quantities using functional dependence between variables.</p> <p>3.A Create experimental procedures that are appropriate for a given scientific question.</p> <p>3.B Apply an appropriate law, definition, theoretical relationship, or model to make a claim.</p>
14.7 Diffraction	<p>2.A Derive a symbolic expression from known quantities by selecting and following a logical mathematical pathway.</p> <p>2.B Calculate or estimate an unknown quantity with units from known quantities, by selecting and following a logical computational pathway.</p> <p>2.D Predict new values or factors of change of physical quantities using functional dependence between variables.</p>
14.8 Double-Slit Interference and Diffraction Gratings	<p>1.B Create quantitative graphs with appropriate scales and units, including plotting data.</p> <p>2.A Derive a symbolic expression from known quantities by selecting and following a logical mathematical pathway.</p> <p>2.B Calculate or estimate an unknown quantity with units from known quantities, by selecting and following a logical computational pathway.</p> <p>2.D Predict new values or factors of change of physical quantities using functional dependence between variables.</p> <p>3.A Create experimental procedures that are appropriate for a given scientific question.</p>

continued on next page

UNIT AT A GLANCE *(cont'd)*

Topic	Suggested Skills
14.9 Thin-Film Interference	<p>1.A Create diagrams, tables, charts, or schematics to represent physical situations.</p> <p>2.B Calculate or estimate an unknown quantity with units from known quantities, by selecting and following a logical computational pathway.</p> <p>2.C Compare physical quantities between two or more scenarios or at different times and locations in a single scenario.</p> <p>3.B Apply an appropriate law, definition, theoretical relationship, or model to make a claim.</p>
	<p>Go to AP Classroom to assign the Progress Check for Unit 14. Review the results in class to identify and address any student misunderstandings.</p>

SAMPLE INSTRUCTIONAL ACTIVITIES

The sample activities on this page are optional and are offered to provide possible ways to incorporate instructional approaches into the classroom. Teachers do not need to use these activities or instructional approaches and are free to alter or edit them. The examples below were developed in partnership with teachers from the AP community to share ways that they approach teaching some of the topics in this unit. Please refer to the Instructional Approaches section beginning on p. 167 for more examples of activities and strategies.

Activity	Topic	Sample Activity
1	14.6	<p>Desktop Experiment Tasks</p> <p>Have students use long springs to create a standing wave. The students make measurements necessary to find the wave speed (wavelength and period data) and the maximum speed attained at an antinode point (amplitude and period data). Students then calculate the wave speed and maximum "particle speed" and see that they are different.</p>
2	14.6	<p>Write and Switch</p> <p>Break students into pairs. Have student A choose one quantity (frequency, wavelength, and wave speed) that stays constant, and a second that either increases or decreases. Student B must state what the third quantity does (increases or decreases) and then describe a situation where a wave undergoes the changes that A prescribed.</p>
3	14.6	<p>Create a Plan</p> <p>Give students several glass bottles. The students choose a song, research its sheet music, fill the bottles with amounts of water calculated to cause the bottles to resonate at the different tones of the song, and then play the song with the bottles.</p>
4	14.6	<p>Desktop Experiment Tasks</p> <p>Break students into groups of 3. Have students blow perpendicularly across a straw while a tone-detecting app on a smartphone is listening. The app registers the fundamental frequency of the standing wave in the straw; students use this and the straw length to calculate the speed of sound. Cut off lengths of straw and repeat, linearizing frequency and wavelength to get the speed of sound.</p>
5	14.6	<p>Four-Square Problem Solving</p> <p>A 2 m long pipe is in a room where the speed of sound in the air is 343 m/s. Square 1: Have students draw the first three harmonics if the pipe is open and calculate the harmonic frequencies. Square 2: Have students draw the first three harmonics if the pipe is closed and calculate the frequencies. Square 3: Have students plot on a number line the first three open frequencies and the first three closed frequencies with different symbols. Square 4: Have students describe the pattern on the number line.</p>
6	14.8	<p>Desktop Experiment Tasks</p> <p>Break students into groups of 3-4 students. Give groups a red/green/purple laser and a diffraction grating. Give wavelength and ask for diffraction slit spacing (or vice versa) experimentally. This can also be performed by finding the width of a human hair or the width of data tracks on a CD or DVD.</p>

SUGGESTED SKILLS

1.C

Create qualitative sketches of graphs that represent features of a model or the behavior of a physical system.

2.C

Compare physical quantities between two or more scenarios or at different times and locations in a single scenario.

3.B

Apply an appropriate law, definition, theoretical relationship, or model to make a claim.

3.C

Justify or support a claim using evidence from experimental data, physical representations, or physical principles or laws.

TOPIC 14.1

Properties of Wave Pulses and Waves

Required Course Content

LEARNING OBJECTIVE

14.1.A

Describe the physical properties of waves and wave pulses.

ESSENTIAL KNOWLEDGE

14.1.A.1

Waves transfer energy between two locations without transferring matter between those locations.

14.1.A.1.i

A wave pulse is a single disturbance that transfers energy without transferring matter between two locations.

14.1.A.1.ii

A wave is modeled as a continuous, periodic disturbance with well-defined wavelength and frequency.

14.1.A.2

Mechanical waves or wave pulses require a medium in which to propagate. Electromagnetic waves or wave pulses do not require a medium in which to propagate.

14.1.A.3

The speed at which a wave or wave pulse propagates through a medium depends on the type of wave and the properties of the medium.

14.1.A.3.i

The speed of all electromagnetic waves in a vacuum is a universal physical constant, $c = 3.00 \times 10^8$ m/s.

continued on next page

LEARNING OBJECTIVE

14.1.A

Describe the physical properties of waves and wave pulses.

ESSENTIAL KNOWLEDGE

14.1.A.3.ii

The speed at which a wave pulse or wave propagates along a string is dependent upon the tension in the string, F_T , and the mass per length of the string.

Relevant equation:

$$v_{\text{string}} = \sqrt{\frac{F_T}{m/\ell}}$$

14.1.A.3.iii

In a given medium, the speed of sound waves increases with the temperature of the medium.

14.1.A.4

In a transverse wave, the direction of the disturbance is perpendicular to the direction of propagation of the wave.

14.1.A.5

In a longitudinal wave, the direction of the disturbance is parallel to the direction of propagation of the wave.

14.1.A.5.i

Sound waves are modeled as mechanical longitudinal waves.

14.1.A.5.ii

The regions of high and low pressure in a sound wave are called compressions and rarefactions, respectively.

14.1.A.6

Amplitude is the maximum displacement of a wave from its equilibrium position.

14.1.A.6.i

The amplitude of a longitudinal pressure wave may be determined by the maximum increase or decrease in pressure from equilibrium pressure.

14.1.A.6.ii

The loudness of a sound increases with increasing amplitude.

14.1.A.6.iii

The energy carried by a wave increases with increasing amplitude.

SUGGESTED SKILLS

1.A

Create diagrams, tables, charts, or schematics to represent physical situations.

2.C

Compare physical quantities between two or more scenarios or at different times and locations in a single scenario.

3.B

Apply an appropriate law, definition, theoretical relationship, or model to make a claim.

3.C

Justify or support a claim using evidence from experimental data, physical representations, or physical principles or laws.

TOPIC 14.2

Periodic Waves

Required Course Content

LEARNING OBJECTIVE

14.2.A

Describe the physical properties of a periodic wave.

ESSENTIAL KNOWLEDGE

14.2.A.1

Periodic waves have regular repetitions that can be described using period and frequency.

14.2.A.1.i

The period is the time for one complete oscillation of the wave.

14.2.A.1.ii

The frequency is the rate at which the wave repeats.

Relevant equation:

$$T = \frac{1}{f}$$

14.2.A.1.iii

The amplitude of a wave is independent of the period and the frequency of that wave.

14.2.A.1.iv

The energy of a wave increases with increasing frequency.

14.2.A.1.v

The frequency of a sound wave is related to its pitch.

14.2.A.1.vi

Wavelength is the distance between successive corresponding positions (such as peaks or troughs) on a wave.

continued on next page

LEARNING OBJECTIVE**14.2.A**

Describe the physical properties of a periodic wave.

ESSENTIAL KNOWLEDGE**14.2.A.2**

A sinusoidal wave can be described by equations for the displacement from equilibrium at a specific location as a function of time. A wave can also be described by an equation for the displacement from equilibrium at a specific time as a function of position.

Example equations:

$$x(t) = A \cos(\omega t) = A \cos(2\pi ft)$$

$$y(x) = A \cos\left(2\pi \frac{x}{\lambda}\right)$$

14.2.A.3

For a periodic wave, the wavelength is proportional to the wave's speed and inversely proportional to the wave's frequency.

Relevant equation:

$$\lambda = \frac{v}{f}$$

SUGGESTED SKILLS

1.A

Create diagrams, tables, charts, or schematics to represent physical situations.

2.C

Compare physical quantities between two or more scenarios or at different times and locations in a single scenario.

3.B

Apply an appropriate law, definition, theoretical relationship, or model to make a claim.

3.C

Justify or support a claim using evidence from experimental data, physical representations, or physical principles or laws.

TOPIC 14.3

Boundary Behavior of Waves and Polarization

Required Course Content

LEARNING OBJECTIVE

14.3.A

Describe the interaction between a wave and a boundary.

ESSENTIAL KNOWLEDGE

14.3.A.1

A wave that travels from one medium to another can be transmitted or reflected, depending on the properties of the boundary separating the two media.

14.3.A.1.i

A wave traveling from one medium to another (for example, a wave traveling between low-mass and high-mass strings), will result in reflected and transmitted waves.

14.3.A.1.ii

A reflected wave is inverted if the transmitted wave travels into a medium in which the speed of the wave decreases.

14.3.A.1.iii

A reflected wave is not inverted if the transmitted wave travels into a medium in which the speed of the wave increases.

14.3.A.1.iv

The frequency of a wave does not change when it travels from one medium to another.

14.3.A.2

Transverse waves that are reflected from a surface, refracted through a medium, or pass through specific openings may be polarized.

14.3.A.2.i

Transverse waves can be polarized and oscillate in a single plane.

14.3.A.2.ii

Longitudinal waves cannot be polarized.

continued on next page

LEARNING OBJECTIVE

14.3.A

Describe the interaction between a wave and a boundary.

ESSENTIAL KNOWLEDGE

14.3.A.3

Polarization of a wave may result in a reduction of the wave's intensity.

14.3.A.3.i

Intensity is a measure of the amount of power transferred per unit area.

14.3.A.3.ii

The intensity of a wave is the average power per unit area over one period of the wave.

SUGGESTED SKILLS

1.A

Create diagrams, tables, charts, or schematics to represent physical situations.

2.C

Compare physical quantities between two or more scenarios or at different times and locations in a single scenario.

3.B

Apply an appropriate law, definition, theoretical relationship, or model to make a claim.

3.C

Justify or support a claim using evidence from experimental data, physical representations, or physical principles or laws.

TOPIC 14.4

Electromagnetic Waves

Required Course Content

LEARNING OBJECTIVE

14.4.A

Describe the properties of an electromagnetic wave.

ESSENTIAL KNOWLEDGE

14.4.A.1

Electromagnetic waves consist of oscillating electric and magnetic fields that are mutually perpendicular.

14.4.A.1.i

Electromagnetic waves are transverse waves because the oscillations of the electric and magnetic fields are perpendicular to the direction of propagation.

14.4.A.1.ii

Electromagnetic waves are commonly assumed to be plane waves, which are characterized by planar wave fronts.

14.4.A.2

Electromagnetic waves do not need a medium through which to propagate.

14.4.A.3

Categories of electromagnetic waves are characterized by their wavelengths.

14.4.A.3.i

Categories of electromagnetic waves include (in order of decreasing wavelength, spanning a range from kilometers to picometers) radio waves, microwaves, infrared, visible, ultraviolet, X-rays, and gamma rays.

14.4.A.3.ii

Visible electromagnetic waves are further broken into categories of color, including (in order of decreasing wavelength) red, orange, yellow, green, blue, and violet.

continued on next page

LEARNING OBJECTIVE

14.4.A

Describe the properties of an electromagnetic wave.

ESSENTIAL KNOWLEDGE

14.4.A.3.iii

Visible electromagnetic waves are also called light. Sometimes, electromagnetic waves of all wavelengths are collectively referred to as light or electromagnetic radiation.

BOUNDARY STATEMENT

AP Physics 2 expects students to know the ordering of the electromagnetic spectrum (including visible light). However, students will not be expected to define exact wavelength ranges within the electromagnetic spectrum.

SUGGESTED SKILLS

1.A

Create diagrams, tables, charts, or schematics to represent physical situations.

2.C

Compare physical quantities between two or more scenarios or at different times and locations in a single scenario.

3.B

Apply an appropriate law, definition, theoretical relationship, or model to make a claim.

3.C

Justify or support a claim using evidence from experimental data, physical representations, or physical principles or laws.

TOPIC 14.5

The Doppler Effect

Required Course Content

LEARNING OBJECTIVE

14.5.A

Describe the properties of a wave based on the relative motion between the source of the wave and the observer of the wave.

ESSENTIAL KNOWLEDGE

14.5.A.1

The Doppler effect describes the relationship between the rest frequency of a wave source, the observed frequency of the source, and the relative velocity of the source and the observer.

14.5.A.2

A greater relative velocity results in a greater measured difference between the observed and rest frequencies.

14.5.A.2.i

For a wave source moving at the same velocity as the observer, the observed frequency is equal to the rest frequency.

14.5.A.2.ii

For a wave source moving toward an observer, the observed frequency is greater than the rest frequency.

14.5.A.2.iii

For a wave source moving away from an observer, the observed frequency is less than the rest frequency.

BOUNDARY STATEMENT

Only qualitative treatments of the Doppler effect are required for AP Physics 2.

TOPIC 14.6

Wave Interference and Standing Waves

Required Course Content

LEARNING OBJECTIVE

14.6.A

Describe the net disturbance that occurs when two or more wave pulses or waves overlap.

ESSENTIAL KNOWLEDGE

14.6.A.1

Wave interference is the interaction of two or more wave pulses or waves.

14.6.A.2

When two or more wave pulses or waves interact with each other, they travel through each other and overlap rather than bouncing off each other.

14.6.A.3

When two or more wave pulses or waves overlap, the resulting displacement can be determined by adding the individual displacements. This is called superposition.

14.6.A.4

Wave interference may be constructive or destructive.

14.6.A.4.i

When the displacements of the superposed wave pulses or waves are in the same direction, the interaction is called constructive interference.

14.6.A.4.ii

When the displacements of the superposed wave pulses or waves are in opposite directions, the interaction is called destructive interference.

14.6.A.4.iii

Two or more traveling wave pulses or waves can interact in such a way as to produce amplitude variations in the resultant wave pulse or wave.

SUGGESTED SKILLS

1.B

Create quantitative graphs with appropriate scales and units, including plotting data.

1.C

Create qualitative sketches of graphs that represent features of a model or the behavior of a physical system.

2.A

Derive a symbolic expression from known quantities by selecting and following a logical mathematical pathway.

2.D

Predict new values or factors of change of physical quantities using functional dependence between variables.

3.A

Create experimental procedures that are appropriate for a given scientific question.

3.B

Apply an appropriate law, definition, theoretical relationship, or model to make a claim.

continued on next page

LEARNING OBJECTIVE

14.6.A

Describe the net disturbance that occurs when two or more wave pulses or waves overlap.

14.6.B

Describe the properties of a standing wave.

ESSENTIAL KNOWLEDGE

14.6.A.5

Visual representations of wave pulses or waves are useful in determining the result of two interacting wave pulses or waves.

14.6.A.6

Beats arise from the addition of two waves of slightly different frequency.

14.6.A.6.i

Waves with different frequencies are sometimes in phase and sometimes out of phase at locations along the waves, causing periodic amplitude changes in the resultant wave.

14.6.A.6.ii

The beat frequency is the difference in the frequencies of the two waves.

Relevant equation:

$$|f_{\text{beat}}| = |f_1 - f_2|$$

14.6.A.6.iii

Tuning forks are devices that are commonly used to demonstrate beat frequencies.

14.6.B.1

Standing waves can result from interference between two waves that are confined to a region and traveling in opposite directions.

14.6.B.1.i

Standing waves have nodes and antinodes. A node is a point on the standing wave where the amplitude is always zero. An antinode is a point on the standing wave where the amplitude is always at maximum.

14.6.B.1.ii

The possible wavelengths of a standing wave are determined by the size and boundary conditions of the region to which it is confined.

14.6.B.1.iii

Common regions where standing waves can form include pipes with open or closed ends, as well as strings with fixed or loose ends.

continued on next page

LEARNING OBJECTIVE

14.6.B

Describe the properties of a standing wave.

ESSENTIAL KNOWLEDGE

14.6.B.2

A standing wave with the longest possible wavelength is called the fundamental or first harmonic. The second-longest wavelength is typically called the second harmonic, the third-longest wavelength is called the third harmonic, and so on. However, for a standing wave with a node at one end and an antinode at the other end, only odd harmonics can be established.

14.6.B.3

Visual representations of standing waves are useful in determining the relationships between length of the region, wavelength, frequency, wave speed, and harmonic.

SUGGESTED SKILLS

2.A

Derive a symbolic expression from known quantities by selecting and following a logical mathematical pathway.

2.B

Calculate or estimate an unknown quantity with units from known quantities, by selecting and following a logical computational pathway.

2.D

Predict new values or factors of change of physical quantities using functional dependence between variables.

TOPIC 14.7

Diffraction

Required Course Content

LEARNING OBJECTIVE

14.7.A

Describe the behavior of a wave and the diffraction pattern resulting from a wave passing through a single opening.

ESSENTIAL KNOWLEDGE

14.7.A.1

Diffraction is the spreading of a wave around the edges of an obstacle or through an opening.

14.7.A.2

Diffraction is most pronounced when the size of the opening is comparable to the wavelength of the wave.

14.7.A.3

Diffraction of multiple wavefronts through a single opening leads to observable interference patterns.

14.7.A.4

Diffraction is commonly demonstrated by monochromatic light of wavelength λ incident on a narrow opening of width a that is a distance L from a screen.

14.7.A.4.i

Constructive and destructive interference of multiple wavefronts originating from the opening will result in bright and dark bands on the screen.

14.7.A.4.ii

The amount of interference between two wavefronts depends on the path length difference ΔD of the wavefronts.

14.7.A.4.iii

The path length difference ΔD can be described in terms of the opening width a and the angle θ between the direction of propagation of the wavefront and the normal to the opening by the equation $\Delta D = a \sin \theta$.

LEARNING OBJECTIVE

14.7.A

Describe the behavior of a wave and the diffraction pattern resulting from a wave passing through a single opening.

ESSENTIAL KNOWLEDGE

14.7.A.4.iv

For small angles, where $\theta < 10^\circ$, the small angle approximation can be used to relate λ , a , and L to y_{\min} , the distance from the middle of the central bright fringe to the m^{th} order of minimum brightness on the screen.

Relevant equation:

$$a \left(\frac{y_{\min}}{L} \right) \approx m\lambda$$

14.7.A.5

The diffraction pattern produced by a wave passing through an opening depends on the shape of the opening.

14.7.A.6

Visual representations of single-slit diffraction patterns are useful in determining the physical properties of the slit and the interacting waves.

SUGGESTED SKILLS

1.B

Create quantitative graphs with appropriate scales and units, including plotting data.

2.A

Derive a symbolic expression from known quantities by selecting and following a logical mathematical pathway.

2.B

Calculate or estimate an unknown quantity with units from known quantities, by selecting and following a logical computational pathway.

2.D

Predict new values or factors of change of physical quantities using functional dependence between variables.

3.A

Create experimental procedures that are appropriate for a given scientific question.

TOPIC 14.8

Double-Slit Interference and Diffraction Gratings

Required Course Content

LEARNING OBJECTIVE

14.8.A

Describe the behavior of a wave and the diffraction pattern resulting from the wave passing through multiple openings.

ESSENTIAL KNOWLEDGE

14.8.A.1

The pattern resulting from monochromatic light of wavelength λ incident on two slits a distance d apart is caused by a combination of wave diffraction and wave interference.

14.8.A.1.i

When only considering wave interference, a double slit creates a pattern of uniformly spaced maxima.

14.8.A.1.ii

Constructive and destructive interference of the wavefronts originating from each slit will result in bright and dark bands on the screen.

14.8.A.1.iii

The amount of interference between two wavefronts depends on the path length difference ΔD of the wavefronts.

14.8.A.1.iv

The path length difference ΔD can be described in terms of the slit separation d and the angle θ between the direction of propagation of the wavefront and the normal to the opening by the equation $\Delta D = d \sin \theta$.

continued on next page

LEARNING OBJECTIVE

14.8.A

Describe the behavior of a wave and the diffraction pattern resulting from the wave passing through multiple openings.

ESSENTIAL KNOWLEDGE

14.8.A.1.v

For small angles, where $\theta < 10^\circ$, the small angle approximation can be used to relate λ , d , and L to y_{\max} , the distance from the middle of the central bright fringe to the m^{th} order of maximum brightness on the screen.

Relevant equation:

$$d \left(\frac{y_{\max}}{L} \right) \approx m\lambda$$

14.8.A.1.vi

When considering wave interference and wave diffraction, a double slit creates an interference pattern of maxima and minima superimposed within the envelope created by single-slit diffraction.

14.8.A.2

Interference patterns produced by light interacting with a double slit indicate that light has wave properties. The source of this discovery was Young's double-slit experiment.

14.8.A.3

Visual representations of double-slit diffraction patterns are useful in determining the physical properties of the slits and the interacting waves.

14.8.A.4

A diffraction grating is a collection of evenly spaced parallel slits or openings that produce an interference pattern that is the combination of numerous diffraction patterns superimposed on each other.

14.8.A.5

When white light is incident on a diffraction grating, the center maximum is white and the higher-order maxima disperse white light into a rainbow of colors, with the longest-wavelength light (red) appearing farthest from the central maximum.

SUGGESTED SKILLS

1.A

Create diagrams, tables, charts, or schematics to represent physical situations.

2.B

Calculate or estimate an unknown quantity with units from known quantities, by selecting and following a logical computational pathway.

2.C

Compare physical quantities between two or more scenarios or at different times and locations in a single scenario.

3.B

Apply an appropriate law, definition, theoretical relationship, or model to make a claim.

TOPIC 14.9

Thin-Film Interference

Required Course Content

LEARNING OBJECTIVE

14.9.A

Describe the behavior of light that interacts with a thin film.

ESSENTIAL KNOWLEDGE

14.9.A.1

When light travels from one medium to another, some of the light is transmitted, some is reflected, and some is absorbed.

14.9.A.2

The phase change of a reflected ray depends on the relative indices of refraction of the materials with which the ray interacts.

14.9.A.2.i

A phase change of 180 degrees occurs when a light ray is reflected from a medium with a greater index of refraction than the medium through which the ray is traveling.

14.9.A.2.ii

No phase change occurs when a light ray is reflected from a medium with a lower index of refraction than the medium through which the ray is traveling.

14.9.A.3

The phase of a wave does not change when it is refracted as it passes from one medium into another.

14.9.A.4

Thin-film interference occurs when light interacts with a medium whose thickness is comparable to the light's wavelength.

14.9.A.4.i

The interactions between the initial reflected light and the light exiting the thin film after being reflected from the second interface exhibit wave interference behavior, resulting in a single wave that is the sum of the two interacting waves.

continued on next page

LEARNING OBJECTIVE**14.9.A**

Describe the behavior of light that interacts with a thin film.

ESSENTIAL KNOWLEDGE**14.9.A.4.ii**

The amount of constructive or destructive interference between the two reflected waves depends on the relationship between the thickness of the film, the wavelength of light, any phase shifts, and the angle at which the incident light strikes the film.

14.9.A.5

Practical examples of thin-film interference include the color variations seen in soap bubbles and oil films, as well as antireflection coatings.

14.9.A.5.i

The spectrum of colors observed in oil films and soap bubbles arises from differences in the thickness of the film.

14.9.A.5.ii

Antireflection coatings eliminate reflected light by applying the relationships between indices of refraction, phase shift, and wave interference to create destructive interference of the light reflected from the two surfaces of the coating.

14.9.A.5.iii

The simplest antireflection coating has a thickness equal to one-quarter of the wavelength of the light in the coating, and the index of refraction of the coating is greater than that of air and less than that of the surface upon which the coating is applied. This assumes incident light is normal to the surface.

BOUNDARY STATEMENT

Quantitative analysis of thin-film interference is limited to waves that are normal to the incident surface.

THIS PAGE IS INTENTIONALLY LEFT BLANK.

AP PHYSICS 2

UNIT 15

Modern Physics



12–15%
AP EXAM WEIGHTING



~14–22
CLASS PERIODS

The AP icon consists of the letters 'AP' in a bold, black, sans-serif font, centered within a white square. This square is set against a light blue circular background that has a subtle gradient and a thin white border.

Remember to go to [AP Classroom](#) to assign students the online **Progress Check** for this unit.

Whether assigned as homework or completed in class, the **Progress Check** provides each student with immediate feedback related to this unit's topic and science practices.

Progress Check 15

Multiple-choice: ~24 questions

Free-response: 4 questions

- Mathematical Routines
- Translation Between Representations
- Experimental Design and Analysis
- Qualitative/Quantitative Translation

Modern Physics



Developing Understanding

ESSENTIAL QUESTIONS

- What are the benefits and dangers of radioactivity?
- How do we measure things we cannot see?
- Why do infrared telescopes need to be cooled?
- How does the infrared catastrophe link thermodynamics and modern physics?

Unit 15 lays the groundwork for the study of modern physics by resolving the conflicts and unanswered questions from Units 13 and 14. While Unit 15 introduces new models and representations (such as energy level diagrams), students will make connections between this unit's content, the fundamental principles of physics, principles of conservation, and models and representations used earlier in the course. These connections will help students make predictions about a variety of phenomena—including radioactive decay rates or nuclear reaction types—and make and justify claims with evidence. Students will also revisit the wave-particle duality of light through their investigations of phenomena such as the photoelectric effect.

Building the Science Practices

2.C 2.D 3.B 3.C

Unit 15 provides opportunities for students to compare physical quantities between scenarios or at different times in a single scenario (**2.C**), as well as determine new values of quantities using functional dependencies between variables (**2.D**). From there, students can also make and justify claims based on these physical principles and functional relationships (**3.B**, **3.C**). For example, when analyzing the photoelectric effect, students could describe conceptually what happens to the maximum kinetic energy of ejected electrons from a metal plate if the plate is replaced by a plate with a higher work function, and then justify what impact that change will have on the required stopping potential. By the end of the unit, it is important for students to be comfortable with making claims about the reasonableness of their claims and justifications made with functional dependence (**2D**, **3.C**) starting with the first principles of physics.

Preparing for the AP Exam

The first free-response question on the AP Physics 2 Exam—the Mathematical Routines (MR) question—focuses assessing students' ability to create and use mathematical models. Students will be required to calculate or derive an expression for a physical quantity. They will also be required to create an/or use a representation and make and justify claims. The final part of the MR question requires students to demonstrate their ability to communicate their understanding of a physical situation in a well reasoned, expository analysis. A student's analysis of the situation should be coherent, organized, and sequential. It should draw from evidence, cite physics principles, and clearly present the student's thinking. While Unit 15 offers content perfect for practice the MR question, the MR question on the AP Physics 2 Exam can pull content from any of the seven units of the course.

UNIT AT A GLANCE

Topic	Suggested Skills
15.1 Quantum Theory and Wave-Particle Duality	<p>1.A Create diagrams, tables, charts, or schematics to represent physical situations.</p> <p>2.A Derive a symbolic expression from known quantities by selecting and following a logical mathematical pathway.</p> <p>2.B Calculate or estimate an unknown quantity with units from known quantities, by selecting and following a logical computational pathway.</p> <p>3.B Apply an appropriate law, definition, theoretical relationship, or model to make a claim.</p>
15.2 The Bohr Model of Atomic Structure	<p>1.A Create diagrams, tables, charts, or schematics to represent physical situations.</p> <p>2.B Calculate or estimate an unknown quantity with units from known quantities, by selecting and following a logical computational pathway.</p> <p>2.C Compare physical quantities between two or more scenarios or at different times and locations in a single scenario.</p> <p>3.B Apply an appropriate law, definition, theoretical relationship, or model to make a claim.</p>
15.3 Emission and Absorption Spectra	<p>1.A Create diagrams, tables, charts, or schematics to represent physical situations.</p> <p>2.B Calculate or estimate an unknown quantity with units from known quantities, by selecting and following a logical computational pathway.</p> <p>2.C Compare physical quantities between two or more scenarios or at different times and locations in a single scenario.</p> <p>3.C Justify or support a claim using evidence from experimental data, physical representations, or physical principles or laws.</p>
15.4 Blackbody Radiation	<p>1.C Create qualitative sketches of graphs that represent features of a model or the behavior of a physical system.</p> <p>2.C Compare physical quantities between two or more scenarios or at different times and locations in a single scenario.</p> <p>3.B Apply an appropriate law, definition, theoretical relationship, or model to make a claim.</p> <p>3.C Justify or support a claim using evidence from experimental data, physical representations, or physical principles or laws.</p>

continued on next page

UNIT AT A GLANCE *(cont'd)*

Topic	Suggested Skills
15.5 The Photoelectric Effect	<ul style="list-style-type: none">1.B Create quantitative graphs with appropriate scales and units, including plotting data.2.A Derive a symbolic expression from known quantities by selecting and following a logical mathematical pathway.2.D Predict new values or factors of change of physical quantities using functional dependence between variables.3.A Create experimental procedures that are appropriate for a given scientific question.3.C Justify or support a claim using evidence from experimental data, physical representations, or physical principles or laws.
15.6 Compton Scattering	<ul style="list-style-type: none">1.A Create diagrams, tables, charts, or schematics to represent physical situations.2.B Calculate or estimate an unknown quantity with units from known quantities, by selecting and following a logical computational pathway.2.C Compare physical quantities between two or more scenarios or at different times and locations in a single scenario.3.C Justify or support a claim using evidence from experimental data, physical representations, or physical principles or laws.
15.7 Fission, Fusion, and Nuclear Decay	<ul style="list-style-type: none">1.B Create quantitative graphs with appropriate scales and units, including plotting data.2.B Calculate or estimate an unknown quantity with units from known quantities, by selecting and following a logical computational pathway.2.C Compare physical quantities between two or more scenarios or at different times and locations in a single scenario.3.A Create experimental procedures that are appropriate for a given scientific question.3.B Apply an appropriate law, definition, theoretical relationship, or model to make a claim.

continued on next page

UNIT AT A GLANCE *(cont'd)***Topic****Suggested Skills****15.8 Types of Radioactive Decay**

1.A Create diagrams, tables, charts, or schematics to represent physical situations.

2.C Compare physical quantities between two or more scenarios or at different times and locations in a single scenario.

3.B Apply an appropriate law, definition, theoretical relationship, or model to make a claim.

3.C Justify or support a claim using evidence from experimental data, physical representations, or physical principles or laws.



Go to **AP Classroom** to assign the **Progress Check** for Unit 15.
Review the results in class to identify and address any student misunderstandings.

SAMPLE INSTRUCTIONAL ACTIVITIES

The sample activities on this page are optional and are offered to provide possible ways to incorporate instructional approaches into the classroom. Teachers do not need to use these activities or instructional approaches and are free to alter or edit them. The examples below were developed in partnership with teachers from the AP community to share ways that they approach teaching some of the topics in this unit. Please refer to the Instructional Approaches section beginning on p. 167 for more examples of activities and strategies.

Activity	Topic	Sample Activity
1	15.3	<p>Concept-Oriented Demonstration</p> <p>Show students a hydrogen discharge tube, and give them a diffraction grating, so they can see the red, cyan, and purple. Tell students that the energy levels of hydrogen can be modeled as $E_n = (-13.6 \text{ eV})/n^2$. Have students estimate the wavelengths of the three colors (based on research) and determine which energy level transitions they are seeing (red 3 to 2, cyan 4 to 2, purple 5 to 2).</p>
2	15.3	<p>Desktop Experiment Tasks</p> <p>Charge a capacitor (at least $10 \mu\text{F}$) to 4.5 V or more, and then discharge it across an LED. Have students record the voltage on the LED and determine its frequency from the LED's color or wavelength (many LEDs come with data sheets with their wavelength listed). Do this for red, orange, yellow, green and blue LEDs. Graph voltage versus frequency and the slope will be Planck's constant in $\text{eV} \cdot \text{s}$.</p>
3	15.7	<p>Desktop Experiment Tasks</p> <p>Break students into groups. Give each group 200 dice in a box with a lid that can be opened. On each "turn" shake the box so that all dice are rolled and then open the box and remove all the dice that land on 1. Record the remaining number of dice. Repeat (without putting the dice back in the box) until all dice are removed. Graph "dice versus turns", and from it determine the "half-life" of the dice (about 3.8 turns).</p>
4	15.7	<p>Identify Subtasks</p> <p>Break students into groups of 2. The student's goal is to determine how many tons of uranium must be mined to meet the electric energy needs of the United States through only nuclear power. Have students identify subtasks in terms of "information we need to research to find" and "calculations we need to make", list the tasks in order they must be done, and then do them and report the findings.</p>

SUGGESTED SKILLS

1.A

Create diagrams, tables, charts, or schematics to represent physical situations.

2.A

Derive a symbolic expression from known quantities by selecting and following a logical mathematical pathway.

2.B

Calculate or estimate an unknown quantity with units from known quantities, by selecting and following a logical computational pathway.

3.B

Apply an appropriate law, definition, theoretical relationship, or model to make a claim.

TOPIC 15.1

Quantum Theory and Wave-Particle Duality

Required Course Content

LEARNING OBJECTIVE

15.1.A

Describe the properties and behavior of an object that exhibits both particle-like and wave-like behavior.

ESSENTIAL KNOWLEDGE

15.1.A.1

Quantum theory was developed to explain observations of matter and energy that could not be explained using classical mechanics. These phenomena include, but are not limited to, atomic spectra, blackbody radiation, and the photoelectric effect.

15.1.A.1.i

Quantum theory is necessary to describe the properties of matter at atomic and subatomic scales.

15.1.A.1.ii

In quantum theory, fundamental particles can exhibit both particle-like and wave-like behavior.

15.1.A.2

Light can be modeled both as a wave and as discrete particles, called photons.

15.1.A.2.i

A photon is a massless, electrically neutral particle with energy proportional to the photon's frequency.

Relevant equations:

$$E = hf$$

$$\lambda = \frac{c}{f}$$

15.1.A.2.ii

Photons travel in straight lines unless they interact with matter.

continued on next page

LEARNING OBJECTIVE

15.1.A

Describe the properties and behavior of an object that exhibits both particle-like and wave-like behavior.

ESSENTIAL KNOWLEDGE

15.1.A.3

The speed of a photon depends on the medium through which the photon travels.

15.1.A.3.i

The speed of all photons in free space is equal to the speed of light, $c = 3.00 \times 10^8$ m/s.

15.1.A.3.ii

In general, the speed of photons through a given medium is inversely proportional to the index of refraction of that medium.

15.1.A.4

Particles can demonstrate wave properties, as shown by variations of Young's double-slit experiment.

15.1.A.4.i

A wave model of matter is quantified by the de Broglie wavelength, which increases as the momentum of a particle decreases.

Relevant equation:

$$\lambda = \frac{h}{p}$$

15.1.A.4.ii

Quantum theory is necessary to describe systems where the de Broglie wavelength is comparable to the size of the system.

15.1.A.5

Values of energy and momentum have discrete, or quantized, values for bound systems described by quantum theory.

SUGGESTED SKILLS

1.A

Create diagrams, tables, charts, or schematics to represent physical situations.

2.B

Calculate or estimate an unknown quantity with units from known quantities, by selecting and following a logical computational pathway.

2.C

Compare physical quantities between two or more scenarios or at different times and locations in a single scenario.

3.B

Apply an appropriate law, definition, theoretical relationship, or model to make a claim.

TOPIC 15.2

The Bohr Model of Atomic Structure

Required Course Content

LEARNING OBJECTIVE

15.2.A

Describe the properties of an atom.

ESSENTIAL KNOWLEDGE

15.2.A.1

Atoms have internal structure.

15.2.A.1.i

Atoms consist of a small, positively charged nucleus surrounded by one or more negatively-charged electrons.

15.2.A.1.ii

The nucleus of an atom is made up of protons and neutrons.

15.2.A.1.iii

The number of neutrons and protons in an atom can be represented using nuclear notation.

15.2.A.1.iv

An ion is an atom with a nonzero net electric charge.

15.2.A.2

Each atomic element has a unique number of protons.

15.2.A.2.i

The number and arrangements of electrons affects how atoms interact.

15.2.A.2.ii

The total number of neutrons and protons identifies the isotope of an element.

15.2.A.2.iii

The mass of an atom is dominated by the total mass of the protons and neutrons in its nucleus.

continued on next page

LEARNING OBJECTIVE**15.2.A**

Describe the properties of an atom.

ESSENTIAL KNOWLEDGE**15.2.A.3**

The Bohr model of the atom is based on classical physics and was the historical representation of the atom that led to the description of the hydrogen atom in terms of discrete energy states.

15.2.A.3.i

In the Bohr model of the atom, electrons are modeled as moving around the nucleus in circular orbits determined by the electron's charge and mass, as well as the electric force between the electron and the nucleus.

Relevant equations:

$$F_e = k \frac{q_1 q_2}{r^2}$$

$$F_{\text{net}} = m \frac{v^2}{r}$$

15.2.A.3.ii

The standing wave model of electrons accounts for the existence of specific allowed energy states of an electron in an atom, because the electron orbit's circumference must be an integer multiple of the electron's de Broglie wavelength.

BOUNDARY STATEMENT

The analysis and description of electron structure is limited to energy levels and will not include such advanced descriptions as orbitals, orbital shapes, or probability functions.

SUGGESTED SKILLS

1.A

Create diagrams, tables, charts, or schematics to represent physical situations.

2.B

Calculate or estimate an unknown quantity with units from known quantities, by selecting and following a logical computational pathway.

2.C

Compare physical quantities between two or more scenarios or at different times and locations in a single scenario.

3.C

Justify or support a claim using evidence from experimental data, physical representations, or physical principles or laws.

TOPIC 15.3

Emission and Absorption Spectra

Required Course Content

LEARNING OBJECTIVE

15.3.A

Describe the emission or absorption of photons by atoms.

ESSENTIAL KNOWLEDGE

15.3.A.1

Energy transfer occurs when photons are absorbed or emitted by an atom, which is modeled as a system consisting of a nucleus and an electron.

15.3.A.2

Energy can only be absorbed or emitted by an atom if the amount of energy being absorbed or emitted corresponds to the energy difference between two atomic energy states.

15.3.A.2.i

An atom in a given energy state may absorb a photon of the appropriate energy and transition to a higher energy state.

15.3.A.2.ii

An atom in an excited energy state may emit a photon of the appropriate energy to spontaneously move to a lower energy state.

15.3.A.2.iii

Because an atom is modeled as a system consisting of an electron and a nucleus, a change in the energy state of an atom corresponds to a change in the interaction energy between the electron and the nucleus.

15.3.A.3

Transitions between two energy states of an atom correspond to the absorption or emission of a photon of a single frequency and, therefore, a single wavelength.

continued on next page

LEARNING OBJECTIVE**15.3.A**

Describe the emission or absorption of photons by atoms.

ESSENTIAL KNOWLEDGE**15.3.A.4**

Atoms of each element have a unique set of allowed energy levels and thereby a unique set of absorption and emission frequencies. The unique set of frequencies determines the element's spectrum.

15.3.A.4.i

An emission spectrum can be used to determine the elements in a source of light.

15.3.A.4.ii

An absorption spectrum can be used to determine the elements composing a substance by observing what light the substance has absorbed.

15.3.A.4.iii

Energy level diagrams are commonly used to visually represent the energy states of an atom.

15.3.A.5

Binding energy is the energy required to remove an electron from an atom, causing the atom to become ionized. An atom in the lowest energy level (ground state) will require the greatest amount of energy to remove the electron from the atom.

BOUNDARY STATEMENT

In AP Physics 2, only energy level diagrams of single-electron atoms will be considered.

SUGGESTED SKILLS

1.C

Create qualitative sketches of graphs that represent features of a model or the behavior of a physical system.

2.C

Compare physical quantities between two or more scenarios or at different times and locations in a single scenario.

3.B

Apply an appropriate law, definition, theoretical relationship, or model to make a claim.

3.C

Justify or support a claim using evidence from experimental data, physical representations, or physical principles or laws.

TOPIC 15.4

Blackbody Radiation

Required Course Content

LEARNING OBJECTIVE

15.4.A

Describe the electromagnetic radiation emitted by an object due to its temperature.

ESSENTIAL KNOWLEDGE

15.4.A.1

Matter will spontaneously convert some of its internal thermal energy into electromagnetic energy.

15.4.A.2

A blackbody is an idealized model of matter that absorbs all radiation that falls on the body. If the body is in equilibrium at a constant temperature, then it must in turn emit energy.

15.4.A.3

A blackbody will emit a continuous spectrum that only depends on the body's temperature. The radiation emitted by a blackbody is often modeled by plotting intensity per unit wavelength as a function of wavelength.

15.4.A.3.i

The distribution of the intensity of a blackbody's spectrum as a function of temperature cannot be modeled using only classical physics concepts. A blackbody's spectrum is described by Planck's law, which assumes that the energy of light is quantized.

15.4.A.3.ii

The peak wavelength emitted by a blackbody (the wavelength at which the blackbody emits the greatest amount of radiation per unit wavelength) decreases with increasing temperature, as described by Wien's law.

Relevant equation:

$$\lambda_{\max} = \frac{b}{T}$$

continued on next page

LEARNING OBJECTIVE**15.4.A**

Describe the electromagnetic radiation emitted by an object due to its temperature.

ESSENTIAL KNOWLEDGE**15.4.A.3.iii**

The rate at which energy is emitted (power) by a blackbody is proportional to the surface area of the body and to the temperature of the body raised to the fourth power, as described by the Stefan-Boltzmann law.

Relevant equation:

$$P = A\sigma T^4$$

SUGGESTED SKILLS

1.B

Create quantitative graphs with appropriate scales and units, including plotting data.

2.A

Derive a symbolic expression from known quantities by selecting and following a logical mathematical pathway.

2.D

Predict new values or factors of change of physical quantities using functional dependence between variables.

3.A

Create experimental procedures that are appropriate for a given scientific question.

3.C

Justify or support a claim using evidence from experimental data, physical representations, or physical principles or laws.

TOPIC 15.5

The Photoelectric Effect

Required Course Content

LEARNING OBJECTIVE

15.5.A

Describe an interaction between photons and matter using the photoelectric effect.

ESSENTIAL KNOWLEDGE

15.5.A.1

The photoelectric effect is the emission of electrons when electromagnetic radiation is incident upon a photoactive material.

15.5.A.2

The emission of electrons via the photoelectric effect requires a minimum frequency of incident light, called the threshold frequency.

15.5.A.2.i

Light that is incident on a material and is at the threshold frequency or higher will induce electron emission, regardless of the number of photons that strike the material.

15.5.A.2.ii

The energy of the emitted electrons is not dependent on the number of photons that are incident upon the material, which provides evidence that light is a collection of discrete, quantized energy packets called photons.

15.5.A.3

The maximum kinetic energy of an emitted electron is related to the frequency of the incident light and the work function of the material, ϕ .

15.5.A.3.i

The work function of a material is the minimum energy required to emit an electron from atoms in the material.

continued on next page

LEARNING OBJECTIVE**15.5.A**

Describe an interaction between photons and matter using the photoelectric effect.

ESSENTIAL KNOWLEDGE**15.5.A.3.ii**

The maximum kinetic energy of an emitted electron is given by the equation

$$K_{\max} = hf - \phi.$$

15.5.A.3.iii

In a typical experimental setup to demonstrate the photoelectric effect and determine the work function of a metal, two metal plates are placed in a vacuum chamber and connected to a variable source of potential difference. One of the plates is illuminated by monochromatic light that causes electrons to be ejected and the potential difference between the plates is adjusted until no current is measured in the circuit.

BOUNDARY STATEMENT

Where applicable, work functions for materials will be provided on the exam; students are not expected to know values of work functions or variables of a material that influence the magnitude of its work function.

SUGGESTED SKILLS

1.A

Create diagrams, tables, charts, or schematics to represent physical situations.

2.B

Calculate or estimate an unknown quantity with units from known quantities, by selecting and following a logical computational pathway.

2.C

Compare physical quantities between two or more scenarios or at different times and locations in a single scenario.

3.C

Justify or support a claim using evidence from experimental data, physical representations, or physical principles or laws.

TOPIC 15.6

Compton Scattering

Required Course Content

LEARNING OBJECTIVE

15.6.A

Describe the interaction between photons and matter using Compton scattering.

ESSENTIAL KNOWLEDGE

15.6.A.1

In Compton scattering, a photon interacts with a free electron. The Compton effect is when a photon that emerges from the interaction has a lower energy and longer wavelength than the incoming photon. The magnitude of the change is related to the direction of the photon after the collision.

15.6.A.2

Compton scattering provides evidence that light is a collection of discrete, quantized energy packets called photons.

15.6.A.2.i

Compton scattering can be explained by treating a photon as a particle and applying conservation of energy and conservation of momentum to the collision between the photon and electron.

15.6.A.2.ii

The transfer of a photon's energy to an electron results in the energy, momentum, frequency, and wavelength of the photon changing.

Relevant equations:

$$E = hf$$

$$\lambda = \frac{h}{p}$$

continued on next page

LEARNING OBJECTIVE**15.6.A**

Describe the interaction between photons and matter using the Compton scattering.

ESSENTIAL KNOWLEDGE**15.6.A.3**

The change in wavelength experienced by a photon after colliding with an electron is related to how much the photon's direction changes.

Relevant equation:

$$\Delta\lambda = \frac{h}{m_e c} (1 - \cos\theta)$$

BOUNDARY STATEMENT

AP Physics 2 includes full quantitative and qualitative treatments of conservation of momentum in two dimensions.

SUGGESTED SKILLS

1.B

Create quantitative graphs with appropriate scales and units, including plotting data.

2.B

Calculate or estimate an unknown quantity with units from known quantities, by selecting and following a logical computational pathway.

2.C

Compare physical quantities between two or more scenarios or at different times and locations in a single scenario.

3.A

Create experimental procedures that are appropriate for a given scientific question.

3.B

Apply an appropriate law, definition, theoretical relationship, or model to make a claim.

TOPIC 15.7

Fission, Fusion, and Nuclear Decay

Required Course Content

LEARNING OBJECTIVE

15.7.A

Describe the physical properties that constrain the behavior of interacting nuclei, subatomic particles, and nucleons.

ESSENTIAL KNOWLEDGE

15.7.A.1

The strong force is exerted at nuclear scales and dominates the interactions of nucleons (protons or neutrons).

15.7.A.2

Possible nuclear reactions are constrained by the law of conservation of nucleon number.

15.7.A.3

The behavior of the constituent particles of a nuclear reaction is constrained by laws of conservation of energy, energy-mass equivalence, and conservation of momentum.

15.7.A.4

For all nuclear reactions, mass and energy may be exchanged due to mass-energy equivalence.

Relevant equation:

$$E = mc^2$$

15.7.A.5

Energy may be released in nuclear processes in the form of kinetic energy of the products or as photons.

15.7.A.6

Nuclear fusion is the process by which two or more smaller nuclei combine to form a larger nucleus, as well as subatomic particles.

15.7.A.7

Nuclear fission is the process by which the nucleus of an atom splits into two or more smaller nuclei, as well as subatomic particles.

15.7.A.8

Nuclear fission may occur spontaneously or may require an energy input, depending on the binding energy of the nucleus.

continued on next page

LEARNING OBJECTIVE**15.7.B**

Describe the radioactive decay of a given sample of material consisting of a finite number of nuclei.

ESSENTIAL KNOWLEDGE**15.7.B.1**

Radioactive decay is the spontaneous transformation of a nucleus into one or more different nuclei.

15.7.B.1.i

The time at which an individual nucleus undergoes radioactive decay is indeterminable, but decay rates can be described using probability

15.7.B.1.ii

The half-life, $t_{1/2}$, of a radioactive material is the time it takes for half of the initial number of radioactive nuclei to have spontaneously decayed.

15.7.B.1.iii

The decay constant λ can be related to the half-life of a radioactive material with the

$$\text{equation } \lambda = \frac{\ln 2}{t_{1/2}}.$$

15.7.B.2

A material's decay constant may be used to predict the number of nuclei remaining in a sample after a period of time, or the age of a material if the initial amount of material is known.

Relevant equation:

$$N = N_0 e^{-\lambda t}$$

Derived equation:

$$\ln\left(\frac{N}{N_0}\right) = -\lambda t$$

15.7.B.3

Different unstable elements and isotopes may have vastly different half-lives, ranging from fractions of a second to billions of years.

SUGGESTED SKILLS

1.A

Create diagrams, tables, charts, or schematics to represent physical situations.

2.C

Compare physical quantities between two or more scenarios or at different times and locations in a single scenario.

3.B

Apply an appropriate law, definition, theoretical relationship, or model to make a claim.

3.C

Justify or support a claim using evidence from experimental data, physical representations, or physical principles or laws.

TOPIC 15.8

Types of Radioactive Decay

Required Course Content

LEARNING OBJECTIVE

15.8.A

Describe the processes by which individual nuclei decay.

ESSENTIAL KNOWLEDGE

15.8.A.1

Some processes by which nuclei decay emit subatomic particles with unique properties.

15.8.A.1.i

An alpha particle, or helium nucleus, consists of two neutrons and two protons and is symbolized by α or He^{2+} . (In Physics 2, only He-4 nuclei will be considered.)

15.8.A.1.ii

Neutrinos and antineutrinos are subatomic particles that have no electrical charge, have negligible mass, and are symbolized by ν and $\bar{\nu}$, respectively.

15.8.A.1.iii

Neutrinos and antineutrinos only interact with matter via the weak force and the gravitational force, which results in very little interaction with normal matter.

15.8.A.1.iv

Positrons, or antielectrons, are subatomic particles that have an electric charge opposite that of an electron, have the same mass as an electron, and are symbolized by e^+ or β^+ .

15.8.A.2

Nuclei can undergo radioactive decay via alpha decay, beta-minus decay (β^-), beta-plus decay (β^+), and gamma decay (γ).

continued on next page

LEARNING OBJECTIVE**15.8.A**

Describe the processes by which individual nuclei decay.

ESSENTIAL KNOWLEDGE**15.8.A.2.i**

In all nuclear decays, nucleon number (the number of neutrons and protons), lepton number (the number of electrons and neutrinos), and charge are conserved.

15.8.A.2.ii

Alpha decay occurs when a nucleus ejects an alpha particle.

15.8.A.2.iii

Beta-minus decay occurs when a neutron changes to a proton by emitting an electron and antineutrino.

15.8.A.2.iv

Beta-plus decay occurs when a proton changes to a neutron by emitting a positron and neutrino.

15.8.A.2.v

Gamma decay occurs after a nucleus has undergone alpha or beta decay and the excited nucleus decays to a lower energy state by emitting a photon.

15.8.A.3

The type of decay exhibited by a given nucleus is determined by the isotope of the element.

BOUNDARY STATEMENT

AP Physics 2 does not expect students to memorize the processes by which specific isotopes decay or the half-lives of specific isotopes. Neutron emission and electron capture are not included in the AP Physics 2 curriculum framework. Additionally, types of neutrinos, the characteristics that distinguish neutrinos and antineutrinos, and an explanation or application of the weak force are not within the scope of this course.

THIS PAGE IS INTENTIONALLY LEFT BLANK.

AP PHYSICS 2

Laboratory Investigations



Lab Experiments

Although laboratory work has often been separated from classroom work, research shows that experience and experimentation are often more instructionally effective. Familiarity with concrete evidence leads to a deeper understanding of course concepts and gives students a sense of ownership of the knowledge they have constructed.

AP Physics courses require students to engage with data in a variety of ways. The analysis, interpretation, and application of quantitative information are vital skills for students. Scientific inquiry experiences in AP Physics 2 should be designed and implemented with increasing student involvement to help enhance inquiry learning and develop critical thinking and problem-solving skills. Typically, the level of investigations in an AP Physics 2 classroom should focus primarily on the continuum between guided and open inquiry. However, depending on students' familiarity with the topic, a given laboratory experience might incorporate a sequence involving all four levels of inquiry (confirmation, structured inquiry, guided inquiry, and open inquiry).

Lab Manuals and Lab Notebooks

College Board publishes *AP Physics 1 and 2 Inquiry-Based Lab Investigations: A Teacher's Manual* on AP Classroom to support the guided inquiry lab requirement for the course. It includes labs that teachers can choose from to satisfy the guided inquiry lab component for the course. Many publishers and science classroom material distributors offer affordable lab manuals with outlined experiments and activities as well as lab notebooks for recording lab data and observations. Students can use any type of notebook to fulfill the lab notebook requirement, even an online document. Consider the needs of the classroom when deciding what type of lab notebook to use.

Lab Materials

A wide range of equipment may be used in the physics laboratory, from generic lab items such as meter sticks, rubber balls, springs, string, metal spheres, calibrated mass sets, beakers, glass and cardboard tubes, electronic balances, stopwatches, clamps, and ring stands to items more specific to physics, such as tracks, carts, light bulbs, resistors, magnets, and batteries. Successful guided inquiry

student work can be accomplished both with simple, inexpensive materials and with more sophisticated physics equipment, such as air tracks, force sensors, and oscilloscopes. Remember that the AP lab should provide an experience for students equivalent to that of a college laboratory, so teachers should make every effort to provide a range of experiences—from experiments students contrive from plumbing pipe, string, and duct tape to experiments in which students gather and analyze data using calculators or computer-interfaced equipment.

There are avenues that teachers can explore as a means of getting access to more expensive equipment, such as computers and probes. Probes can often be rented for short periods of time from instrument suppliers. Alternatively, local colleges or universities may allow high school students to complete a lab as a field trip on their campus, or they may allow teachers to borrow their equipment. They may even donate their old equipment. Some schools have partnerships with local businesses that can help with laboratory equipment and materials. Teachers can also utilize online donation sites, such as Donors Choose and Adopt-A-Classroom.

Lab Time

For AP Physics 2 to be comparable to a college physics course, it is critical that teachers make laboratory work an important part their curriculum. An analysis of data from AP Physics 2 examinees regarding the length of time they spent per week in the laboratory shows that increased laboratory time correlates with higher AP scores. Flexible or modular scheduling must be implemented to meet the time requirements identified in the course outline. Furthermore, it is important that the AP Physics 2 laboratory program be adapted to local conditions and funding, as it aims to offer the students a well-rounded experience with experimental physics. Adequate laboratory facilities should be provided so that each student has a work space where equipment and materials can be left overnight if necessary. Sufficient laboratory equipment for the anticipated enrollment and appropriate instruments should be provided. Students in AP Physics 2 should have access to computers with software appropriate for processing laboratory data and writing reports.

How to Set Up a Lab Program

Physics is a way of approaching scientific discovery that requires personal observation and physical experimentation. Being successful in this endeavor requires students to synthesize and use a broad spectrum of knowledge and skills, including mathematical, computational, experimental, and practical skills, and to develop habits of mind that might be characterized as thinking like a physicist. Student-directed, inquiry-based lab experience supports the AP Physics 2 course and AP Course Audit curricular requirements. It provides opportunities for students to design experiments, collect data, apply mathematical routines and methods, and refine testable explanations and predictions. Teachers are expected to devote a minimum of 25% of instructional time to lab investigations to support the learning objectives in the course framework.

The AP Physics 2 Exam directly assesses the learning objectives of the course framework, which means the inclusion of appropriate experiments aligned with those learning objectives is important for student success. Teachers should select experiments that provide students with the broadest laboratory experience possible.

We encourage teachers to be creative in designing their lab program while ensuring students explore and develop understandings of these core techniques. After completion, students should be able to describe how to construct knowledge, model (create an abstract representation of a real system), design experiments, analyze visual data, and communicate physics. Students should also develop an understanding of how changes in the design of the experiments would impact the outcome of their results. Many questions on the AP Exam are written in an experimental context, so these skills will prove invaluable for both concept comprehension and exam performance. Because AP Physics 2 is equivalent to a college course, the equipment and time allotted to laboratories should be similar to that in a college course. Therefore, schools must ensure that students have access to scientific equipment and all materials necessary to conduct hands-on, college-level physics laboratory investigations.

Getting Students Started

There are no prescriptive “steps” to the iterative process of inquiry-based investigations. However, there are some common characteristics of inquiry that will support students in designing their investigations. Often, this simply begins with using the learning objectives to craft a question for students to investigate. Teachers may choose to give students a list of materials they are allowed to use in their design, or require that students request the equipment they feel they need to investigate the question. To use learning objectives when crafting questions, consider the following points:

- Select learning objectives from the course framework that relate to the subject under study and may set forth specific tasks, in the form of “Design an experiment to ...”
- Rephrase or refine the learning objectives that align to the unit of study to create an inquiry-based investigation for students.

Students should be given latitude to make design modifications or ask for additional equipment appropriate for their design. It is also helpful for individual groups to report out to the class on their basic design to elicit feedback on feasibility. Guided student groups can proceed through the experiment, with the teacher allowing them the freedom to make mistakes—as long as those mistakes don't endanger students or equipment or lead the groups too far off task. Students should have many opportunities for post-lab reporting so that groups can understand the successes and challenges of individual lab designs.

Communication, Group Collaboration, and the Laboratory Record

Laboratory work is an excellent means through which students can develop and practice communication skills. Success in subsequent work in physics depends heavily on an ability to communicate about observations, ideas, and conclusions to others. By

working together in a truly collaborative manner to plan and carry out experiments, students learn oral communication skills and teamwork. Students must be encouraged to take full individual responsibility for the success of the collaboration and not be a sleeping partner ready to blame the rest of the team for failure.

After students are given a question for investigation, they may present their findings either in a written or an oral report to the teacher and the class for feedback and critique on their final design and results. Students should be encouraged to critique and challenge one another's claims based on the evidence collected during the investigation.

Laboratory Safety

Giving students the responsibility for design of their own laboratory experience involves special responsibilities for teachers. To ensure a safe working environment, teachers should first provide the limitations and safety precautions necessary for potential procedures and equipment students may use during their investigation. Teachers should also provide specific guidelines prior to students' discussion on investigation designs for each experiment, so that those precautions can be incorporated into the final student-selected lab design and included in the background or design plan in a laboratory record. It may also be helpful to print the precautions that apply to

that specific lab as Safety Notes to place on the desk or wall near student workstations. Additionally, a general set of safety guidelines should be set forth for students at the beginning of the course. The following is a list of possible general guidelines teachers may post:

- Before each lab, make sure you know and record the potential hazards involved in the investigation, as well as the precautions you will take to stay safe.
- Before using equipment, make sure you know the proper use to acquire good data and avoid damage to equipment.
- Know where safety equipment is located in the lab, such as the fire extinguisher, safety goggles, and the first aid kit.
- Follow the teacher's special safety guidelines as set forth prior to each experiment. (Students should record these as part of their design plan for a lab.)
- When in doubt about the safety or advisability of a procedure, check with the teacher before proceeding.

Teachers should interact constantly with students as they work to observe safety practices and anticipate and discuss with them any problems that may arise. Walking among student groups and asking questions allows teachers to take the pulse of what students are doing and maintain a watchful eye for potential safety issues.

Laboratory Investigations

Introduction

Laboratory investigations, experiments, and activities (“labs”) are the cornerstone of many successful physics classrooms. Labs give students the opportunity to investigate behaviors of objects and systems, make observations, and develop their own explanations and understandings of the physical world. Within labs, students explore patterns and systems to make conclusions that can be used to predict future outcomes. This cycle of observation, measurement, recording, analyzing, and concluding is the backbone of all science. Justifying conclusions by applying the knowledge, concepts, and principles that are discussed in lecture or classwork sessions to tangible material connects physical actions to conceptual understanding. Labs provide students with an additional way to encode information, which increases the methods by which they are able to retrieve and apply that information. An analysis of data from AP Physics examinees regarding the length of time they spent per week in the laboratory shows that increased lab time correlates with higher AP Exam scores.

Descriptions of Labs

AP Physics courses require that 25 percent of instruction time is spent in hands-on laboratory work. In practice, this translates to be approximately one classroom period per week that is devoted to lab-related activities. This average can be implemented in a variety of ways. Some teachers do lab on the same day every week, using a weekly cycle of content, practice, application, and low-stakes formative assessment. Others prefer to do one “big” or more complex lab every two weeks. Some teachers prefer to thread quick 20-minute “mini labs” throughout their daily classroom routines. Some teachers plan a few investigative labs at the start of a unit, then spend significant class time on practice, discussion, and application of concepts; and then end the unit with one or two more complex labs that incorporate content from the entire unit. And even further still, some teachers do some combination of all of the above. Any approach is acceptable as long as the 25 percent requirement is met.

Defining “Labs” and “Lab Time”

Perhaps the most common questions asked by teachers who are planning their lessons are variations of:

- “What counts as a lab?”
- “What counts as time spent on labs?”
- “Do labs need to take the entire class period?”
- “Do students need to be in the ‘lab’ part of the classroom to count as lab time?”
- “Do digital or online lab simulations count for lab time?”
- “Do labs need to have formal write-ups?”

Labs

For AP Physics, a *lab* is performed any time data is collected and/or analyzed. A follow-up question might then be: “What is the threshold for collecting data?” For AP Physics, data is collected any time a student writes down an observation or measurement. Data can be qualitative, such as “The two pieces of tape must be oppositely charged because they attract” or quantitative “current in the wire is 0.1 A.” Data can be recorded in many ways, such as tables, lists, or paragraphs. The analysis itself can also be qualitative or quantitative, as appropriate for the objective of the lab.

Lab Time

For AP Physics, *lab time* is any time spent in the classroom that supports the act of doing a lab, as defined above. This includes, but is not limited to:

- Time spent discussing the goal and objectives of a lab.
- Setup of equipment and lab stations.
- “Pre-lab” questions and activities, such as identifying what to measure, developing and writing experimental procedures, sketching lab setups, creating data tables to complete, etc.
- Performing experimental procedures.
- Collecting, plotting, and analyzing data as needed.
- “Post-lab” activities, such as interpreting, comparing, and discussing the results of the lab, connecting these results to course content, or developing extension questions.
- Cleanup of equipment and lab stations.

Note that all of the above can be done individually, in small lab groups, or as an entire class, as deemed appropriate for any given teacher’s students and class within the context of a specific lab. There are times

when it is appropriate to simply let students explore on their own, and other times when more specific instructions and directions are required (either because of complexity or safety, or both). Sometimes a long summary and review session is not needed, other labs benefit from having the entire class share their data and make conclusions using this larger pool of data. All this time spent supporting the lab may be counted as *lab time*.

Types of Labs

Most labs can be broadly categorized into three types: Investigations, Verifications, and Applications.

Investigation labs are activities where students are asked to induce an outcome and discover mathematical relationships or qualitative properties without having been taught the answer in the classroom. For example, a lab may pose the question: "What is the relationship between the current in a resistor and the potential difference across that resistor?" Obviously prior to this lab, teachers will have given definitions of potential difference and current, but will not have discussed Ohm's law. Students will determine what data to record, how to obtain that data, make measurements, and then make a conclusion about the relationship between the current in a resistor and the potential difference across that resistor.

The purpose of investigative labs is to have students create their own understanding of the behavior of a physical system. When created on its own, this understanding may provide a much more solid foundation upon which the student can build further knowledge than when that same student is simply told the answers. A real, tangible, physical experience is often much easier to relate to and remember. The phrase "Remember when you did ..." can be much more accessible than "Imagine you will ..."

Note that if students already know the relationship between impulse and the change in momentum, an investigation lab is easily turned into a verification lab.

Verification labs confirm information students have already been provided. Depending on the approach of the teacher, these labs can also be beneficial and useful in the classroom. However, the power of self-discovery should not be undervalued as a tool with which students make their learning more permanent. Often the act of learning is made more visceral when the student discovers the answer on their own, rather than confirming the answer found by others.

An *application lab* is when students are asked to apply a known physical principle or idea to a lab setup in order to find an answer. For example, a lab may ask students

to "Determine the resistance of an unknown resistor, by measuring the current in the resistor and the potential across the resistor." For this lab, students already know that $\Delta V = IR$ and apply that relationship to accomplish the objective of the lab. Application labs serve multiple purposes as well. These labs provide a definite answer to a specific question. This answer is typically easy to assess as "right" or "wrong." If students experimentally determine that the resistance of the resistor is 498Ω , then determine the resistance from a resistor color chart to be $500 \pm 1\% \Omega$, that provides instant feedback on how well the students applied physics, laboratory skills, and the quality of their measurements. A lab group that obtains 682Ω for the same resistor has similar instant feedback.

In an application lab, an unexpected result that significantly departs from the expected result should lead to one of two conclusions. Either: "The physics my teacher told me is wrong and we have discovered new physics!" or "Perhaps I made a mistake, and I should find it and fix it." Given the extraordinarily high probability that Ohm's law was not suddenly disproven in a single high school physics lab, this result should lead to double-checking measurements and procedures, recalibration of equipment, or finding other errors in their methods or data. The ability for students to use instant feedback to check the accuracy of their work can be an invaluable tool used to develop student confidence as well as refine skills and understanding. Even when students do not obtain the "right" answer the first time, with proper coaching and encouragement from the teacher, a student can earn a tremendous feeling of pride and accomplishment after self-correcting. Not only does this student learn how to overcome their mistakes, but the learning may also then be associated with positive outcomes.

Lab Skills

Labs should be selected to implement a wide variety of appropriate scientific skills. Within the context of AP Physics, all three skills within Science Practice 3: Scientific Questioning & Argumentation are appropriate to emphasize. However, in the act of performing an experiment, students may also demonstrate any of the other AP Physics Science Practices and skills. As such, teachers should intentionally choose which skills to emphasize, and when. For instance, some labs may require meticulous measurement and data collection, while others only need qualitative observations. Teachers are encouraged to choose labs that represent all the skills students will need to become well-rounded scientists and physicists. No single type of lab or

instructional approach can provide a one-size-fits-all solution for students in the classroom. Students benefit from a variety of strategies and approaches to gain a deep, comprehensive understanding of physics concepts.

Some suggested variation in lab skills include:

- Labs that have small details that require careful attention as well as labs that are impossible to “mess up.”
- Labs that require students to repeat the same measurement many times to find an average as well as labs where students must change a single quantity in order to find a relationship between two variables.
- Labs that require graphical linearization and complex mathematical derivation to determine an experimental value as well as labs that have simple conclusions based on qualitative observations.

Lab Formats

Labs may appear in a variety of formats. For a quick 15-minute demonstration where students make observations and conclusions, students may simply write their observations on the front of an index card and their conclusions on the back side of that same card. There is no one right way to do labs in the classroom; there are many different methods by which success can be found. Some suggested lab formats include:

- Printing out pages for students to complete
- Requiring students to keep detailed laboratory notebooks
- Combination approach, including both printed workbook style pages and full laboratory notebooks.
- Classic lab manual and full lab report style.

Teachers are encouraged to use routine to their advantage in the lab. If structures and routines are introduced at the start of the academic year, the complexity of labs that can be performed throughout the course can be increased. At the start of the year, teachers can reinforce and emphasize the lab skills themselves (developing procedures, recording data effectively, analysis methods, etc.) in the context of more accessible content. For example, if the goal of a lab is to analyze the speed of a bowling ball as it rolls down a hallway, students can typically develop and refine a scientific method of doing so without having to use complex experimental equipment and setups or nuanced physics. Later in their studies, a lab could have students investigate the relationship between the density of a fluid

and the acceleration of an object through that fluid. While this lab would require specific equipment as well as more complex data collection and analysis, students would be able to focus on these complexities because they have practiced the foundational lab skills and techniques throughout the course.

Observing and Measuring the Small

Where AP Physics 1 typically investigates macroscopic interactions, AP Physics 2 addresses the properties of microscopic interactions. Labs are the perfect opportunity for students to explore how the invisible can be made visible. By observing macroscopic patterns, trends, and behaviors, students can develop their own conclusions about the nature of the microscopic world and use conclusions to make and test predictions about the natural world.

AP Physics 2 presents many opportunities to explore large-scale patterns of small-scale interactions in ways that are directly related to students' everyday lives. For instance, the classic “drinking bird” toys can be used as a bridge that connects AP Physics 1 topics (torque, rotation, and fluids) to AP Physics 2 topics (thermodynamics and the ideal gas law). Students can develop and evaluate models about how the toy works, and then test those models by changing the experiment: What does my model predict will happen if we heat the bottom of the bird? What does my model predict will happen if the bird drinks ice water or room temperature water?

AP Physics 2 also explains how a multitude of everyday objects work. The first time students see the image of a candle flame projected by a lens onto a screen can be a memorable experience. Students can then investigate magnification and focus of that same image and relate those ideas to how corrective lenses work. The magnetic strip on the back of a credit card can be modeled using coin-sized magnets that are flipped so that their poles follow a binary pattern (e.g., N-S-S-N-N-N-S). Students can then use a magnetometer to “read” the “credit card” and match each credit card to its “owner.”

An example of measuring the small with large tools is asking students to determine the width of a hair, using a laser pointer and meterstick. This experiment can be repeated using various colors of lasers: red, green, and blue. Rich discussions and deeper understanding of the principles at work can be emphasized as well: Which laser pointer has the best results, and why? How can we use a diffraction grating to verify the properties of the lasers? Is the hair from a dog's tail the same thickness as a hair from the same dog's back? What is the

relationship between the thickness of a cat’s whisker to its length? Can we use a laser pointer to differentiate a CD from a DVD?

Lab Equipment

There are no requirements for lab equipment in AP Physics. It is possible to develop a successful and robust sequence of labs that only require the most basic materials. However, there is a wide range of equipment, sensors, and tools that are available to teachers to use to augment their collection of metersticks and stopwatches. A list of the most commonly used lab equipment is provided below. While students do not need to have personal experience with each of these tools, they need to be made aware of this equipment, as well as the uses for each piece.

Generic Lab Equipment

- Stands, 90-degree cross supports, and clamps, of varying sizes and design.
- Metersticks
- Scale (digital, triple-beam balance, etc.)
- String
 - Often heavy-duty fishing line is the best “physics” string. Fishing line is inexpensive, thin, easily available, and strong. Cotton twine is often too thick or breaks too easily, and nylon string can be difficult to tie in a reliable knot.
- Tape (including masking tape, painter’s tape, duct tape, clear tape, etc.)
- Scissors
- Glue and/or glue sticks
- Assorted spheres, balls, and masses.

Physics-Specific Optional Lab Equipment

- Multimeter (Voltmeter/Ammeter/Ohmmeter)
- Capacitance Meter
- Adjustable DC Power Supply
- Pressure Sensor
- Magnetometer
- Thermometer
- Fluid Flow Meter
- Cell Phones
 - Modern cell phones are packed with sensors, cameras, and apps that can be easily and appropriately implemented in the classroom. Cell phones have stopwatches, video cameras (and most with slow-motion or even time-lapse capabilities), accelerometers that can be used to measure angles and acceleration, magnetometers, microphones, GPS, etc. Additionally, there are many free apps that students can download that take advantage of these sensors within a physics lab setting. Cell phones can be used if available but are not required. For most laboratory investigations where data collection with cell phones is desired, one phone per group will suffice.
- Video Analysis/Computer Software
 - There are multiple options for computer software and video analysis of varying cost and functionality. Electronic sensors should come with the software needed to operate those sensors. More robust software can use collected data to measure the area under a curve, or perform curve-fitting analyses or linear regressions, and more.

THIS PAGE IS INTENTIONALLY LEFT BLANK.

AP PHYSICS 2

Instructional Approaches



Selecting and Using Course Materials

Selecting and Using Course Materials

Teachers will benefit from a wide array of materials to help students become proficient with the science practices necessary to develop a conceptual understanding of the relationships, laws, and phenomena studied in AP Physics 2. In addition to using a college-level textbook that will provide required course content, students should have regular opportunities to create and use data, representations, and models through supplemental material such as TIPERs (Tasks Inspired by Physics Education Research). Rich, experimental investigation is the cornerstone of AP Physics 2, and diverse source material allows teachers more flexibility in designing the types of learning activities that will help develop the habits of thinking like a physicist.

Textbooks

While nearly all college-level physics textbooks address the seven units of AP Physics 2, it's important for teachers to identify other types of secondary sources (such as lab manuals, student workbooks, TIPERs, etc.) to supplement the chosen textbook, accordingly, ensuring that each of the eight topic areas, as well as the science practices, receives adequate attention. AP Central provides an example textbook list to help determine whether a text is considered appropriate in meeting the AP Physics 2 Course Audit resource requirement. Teachers can also select textbooks locally.

Guided Inquiry in AP Physics 2

The more active students are in their science education, the more scientifically literate they will become. Inquiry into authentic questions generated from student experiences should be one of the central strategies when teaching AP Physics 2. By posing questions, planning investigations to answer those questions, and reviewing what is already known in light of experimental

evidence, students mirror how scientists analyze the natural world. Inquiry requires identifying assumptions, using critical and logical thinking, and considering alternative explanations. Having students probe for answers to scientific questions will lead to a deeper understanding of scientific concepts.

Skill	How to Scaffold Inquiry in the AP Classroom			
	MORE	← AMOUNT OF DIRECTION FROM TEACHER →		LESS
1.A Create diagrams, tables, charts, or schematics to represent physical situations.	The student works with a representation provided by the teacher.	The student selects from a set of representations provided by the teacher.	The student sharpens, completes, or augments a representation provided by the teacher.	The student creates their own representation.
1.B Create quantitative graphs with appropriate scales and units, including plotting data.	The student works with a graph provided by the teacher.	The student plots data on a graph that is labeled and scaled, but not fully completed, by the teacher.	The student applies appropriate scales and plots data on a graph where the axes have been labeled for the student by the teacher.	The student creates appropriate graphs with scales and units, including plotting data, on their own.
1.C Create qualitative sketches of graphs that represent features of a model or the behavior of a physical system.	The student works with sketches of graphs that are provided by the teacher.	The student is able to identify important characteristics of a sketch of a given scenario (i.e., whether the quantity should be increasing or decreasing, but not necessarily whether it is concave up or down).	The student creates a sketch that represents a feature of a model, based on a sketch from a slightly different scenario, either provided by the teacher or reviewed previously.	The student creates sketches of graphs that represent features of a model or the behavior of a system on their own.
2.A Derive a symbolic expression from known quantities by selecting and following a logical mathematical pathway.	The student works with a derivation provided by the teacher.	The student is given possible starting points for a derivation by the teacher.	The student selects from a set of given derivations provided by the teacher.	The student derives an expression using physics concepts and principles on their own.

How to Scaffold Inquiry in the AP Classroom

Skill	MORE	← AMOUNT OF DIRECTION FROM TEACHER →	LESS	
<p>2.B Calculate or estimate an unknown quantity with units from known quantities, by selecting and following a logical computational pathway.</p>	The student works with a calculation provided by the teacher.	The student is given possible starting points for a calculation provided by the teacher.	The student is given possible starting points for a calculation by the teacher.	The student performs a calculation on their own using physics concepts and principles.
<p>2.C Compare physical quantities between two or more scenarios or at different times and locations in a single scenario.</p>	The student is given the relationship or pattern between quantities by their teacher.	The student is given possible relationships or patterns to choose from to compare quantities.	The student is directed toward possible patterns or relationships by the teacher.	The student can examine relationships and form links to explanations on their own.
<p>2.D Predict new values or factors of change of physical quantities using functional dependence between variables.</p>	The student is given a scenario and an equation by the teacher and is instructed how to analyze the scenario using the given equation.	The student is given possible equations or relationships between variables for a given scenario by the teacher and is asked to choose the equation or relationship that could be helpful in analyzing the scenario.	The student is directed first toward principles that will help start a derivation to make claims about the functional dependence between variables in a given scenario.	The student can derive relationships and make claims about the functional dependence between variables in a given scenario on their own.
	The student is given data by the teacher and is told how to analyze it.	The student is given data to analyze by the teacher.	The student is directed to collect and analyze certain data by the teacher.	The student can determine both what constitutes evidence to support a claim and collect it on their own.
<p>3.A Create experimental procedures that are appropriate for a given scientific question.</p>	The student works with a procedure provided by the teacher.	The student selects from a set of given procedures provided by the teacher.	The student sharpens or completes or augments an outline of a procedure provided by the teacher.	The student determines a procedure on their own.
<p>3.B Apply an appropriate law, definition, theoretical relationship, or model to make a claim.</p>	The student is given procedures, relationships, or data by the teacher to make claims and predictions.	The student is given broad guidelines to sharpen claims and predictions.	The student is coached in the development of claims and predictions using evidence summarized by the teacher.	The student devises a claim or prediction after summarizing the evidence.
<p>3.C Justify or support a claim using evidence from experimental data, physical representations, or physical principles or laws.</p>	The student is provided with evidence from the teacher to support an explanation.	The student is given possible ways to use evidence to create explanations by the teacher.	The student is guided through the process of formulating explanations from evidence.	The student can form reasonable and logical arguments to communicate explanations based on scientific theories and models on their own.

Understanding the different types of inquiry can help teachers scaffold the types of labs and activities to better meet the needs of their students.

Below are four suggestions to make labs and activities more student-centered and inquiry-based:

- **Start small:** Take out the “data” or “results” section from traditional labs. If the procedure is thorough and simple enough, students can read and design the data and results sections on their own.
- **Tackle the procedure:** Eventually, teachers will want students to design their own experiments, but students may need some practice first. Remove the step numbers and shuffle the steps in a given procedure. Have the students work in pairs to put the steps into the correct order. Next, try having them write a procedure as a pre-lab homework assignment, and then work together as a class to develop it further, making sure that the question, variables, and safety are addressed.
- **Try a goal-oriented task:** Completely remove the procedure, and prompt students with a question that asks them to achieve something they want to do. At this point, it’s best to choose a lab that students already understand conceptually and that uses simple, familiar equipment.
- **Let students do the thinking:** Create opportunities for students to choose what they will investigate. Facilitate their thought process without telling them what to do. A pre-lab brainstorming session in small groups is helpful when having students develop a question to investigate. It is important to provide students with some guidelines at this step. For example, students need to think about a question, a hypothesis, and materials before beginning an open-ended lab. Seeing and approving this in lab groups can help boost students’ confidence.

Instructional Strategies

The AP Physics 2 course framework outlines the concepts and science practices students must be proficient in order to be successful on the AP Exam. To address those concepts and science practices effectively, teachers can incorporate a variety of instructional approaches and best practices into their daily lessons and activities. Teachers can help students develop the science practices by engaging them in learning activities that allow them to apply their understanding of course concepts. Teachers may consider the following strategies as they plan instruction. Please note they are listed alphabetically and not by order of importance or instruction.

Strategy	Description	Example
<i>Ask the Expert</i>	Students are assigned as “experts” for concepts they understand well; groups rotate through the expert stations to learn about concepts they need to work on, providing students with opportunities to share knowledge and learn from one another.	Assign students as “experts” on atomic, quantum, or nuclear questions. Have them rotate through stations in groups, working with the station expert to justify a set of claims pertaining to each question with corresponding physical laws as evidence. “Experts” can be swapped out at any point during the rotation so that all students have the opportunity to lead work and engage with multiple problems.
<i>Changing Representations</i>	Students translate from one representation (e.g., an electric field diagram) to another (e.g., an equipotential curve or surfaces diagram). This may involve creating pictures, tables, graphs, lists, equations, models, and/or verbal expressions to interpret text or data.	As students learn about energy conservation in circuits, ask them to move between different representations of circuits. For example, if given a sketch of a simple circuit, have students create a circuit diagram, a set of equations using Kirchhoff’s rules, and a graph of potential around the circuit, ensuring that they are able to move freely between these representations as well as use them for evidence in support of claims.
<i>Concept-Oriented Demonstration</i>	Students create a description, prediction, and/or explanation for a demonstration done by a teacher.	Although most students will already know the outcome, the “soda can crushing” experiment (available to see on the Internet) can be demonstrated in Unit 2 to challenge students to explain how and/or why the phenomena occurred in terms of physical laws and theories.

continued on next page

Strategy	Description	Example
Conflicting Contentions	Students are presented with two or three statements that disagree in some way. Then they have to decide which contention they agree with and explain why.	<p>Present students with the following scenario:</p> <p>A train traveling at a constant speed along a straight track approaches an observer sitting on the ground near the track, while the train sounds its horn.</p> <p>Then ask students to justify the following claims.</p> <p>Claim 1: <i>Since the train is traveling at a constant speed, the pitch of the horn as measured by an observer on the ground will be constant and match the pitch of the horn as heard by an observer at rest relative to the train.</i></p> <p>Claim 2: <i>Even though the train is moving at a constant speed, the pitch of the horn heard by the observer on the ground will be higher than the pitch of the horn as heard by an observer at rest relative to the train.</i></p> <p>Claim 3: <i>An observer on the ground will hear a higher pitch horn, and the pitch will increase as the train gets closer to the observer.</i></p>
Construct an Argument	Students use mathematical reasoning to present assumptions about mathematical situations, evaluate mathematical information, support conjectures with mathematically relevant and accurate data, and provide a logical progression of ideas leading to a reasonable conclusion.	<p>Provide students with the following setup: A long string is attached at one end to an oscillator. The string is then placed over a pulley and the other end of the string is attached to an object of mass m. The oscillator is turned on and oscillates with frequency f and two full standing waves form on the string between the oscillator and the pulley.</p> <p>Have students create an argument for whether the mass m should be increased or decreased to increase the number of standing waves on the string with the same frequency, f.</p>
Create a Plan	Students analyze the tasks in a problem and create a process for completing the tasks. They find the information needed, interpret data, choose how to solve the problem, communicate the results, and verify accuracy.	Break students into groups of three or four students. Scaffold the process of designing an experiment by having each group outline the following experiment. "Design an experiment to determine the number of moles of a gas in a syringe full of a specific gas using only known masses and a meterstick (no pressure sensor). Have students identify the steps needed to answer the question, including collecting and analyzing data, as well as what to do with the collected data.

continued on next page

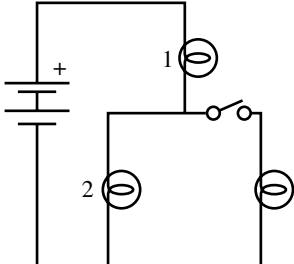
Strategy	Description	Example
Debriefing	Students discuss the understanding of a concept to lead to a consensus on its meaning while clarifying misconceptions and deepening understanding of context.	Have students place a converging lens between a light source and a screen. Have students move the screen until a real image is formed on the screen. Have them repeat this process for different distances between the lens and the light source. Have them plot the inverse of the distance between the light source and the lens versus the inverse of the distance between the lens and the image. Have students draw a line of best fit and have them discuss how they could determine the focal length of the lens using their data.
Desktop Experiment Tasks	Students perform a demonstration at their desks (either in class or at home) using a predict-and-explain format but add the step of actually doing the experiment. This “doing it” step consists of using the apparatus provided to answer a given question, and is followed by a reformulating step, where students reconsider their previous explanations while considering the results of the experiment.	<p>Have students analyze the following circuit diagram and predict what will happen to the brightness of bulbs 1, 2, and 3 when the switch is closed. Then have students build the circuit at their desks using batteries and holiday light bulbs to confirm their prediction.</p> 
Discussion Groups	Students work within groups to discuss related content, create problem solutions, and explain and justify a solution.	As a review for the AP Physics 2 Exam, assign students to think about how something they have learned in class relates to something they use in everyday life. Have them share out how the thing they have chosen works in terms of concepts presented in class.

continued on next page

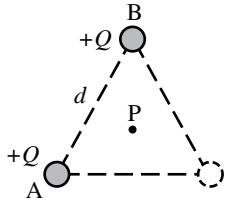
Strategy	Description	Example
<p>Friends Without Pens</p>	<p>Students solve problems by engaging in two “rounds” of timed work — in groups and then independently. In the first round, called “friends without pens,” students are grouped together to discuss the problem but are not permitted to write anything. In the second round, called “pens without friends,” students return to their desk where they complete and finalize their responses to the problem individually, using any information they remember from their group discussion and their own knowledge of course concepts.</p>	<p>Present students with the following scenario:</p>  <p>Particles A and B each have positive charge $+Q$ and are held fixed at two vertices of an equilateral triangle of side length d, as shown in the figure. Point P is located equidistant from each vertex of the triangle. Students Y and Z discuss the electric field and the electric potential at Point P after a third charged particle is placed at the bottom-right vertex. The students make the following statements.</p> <p>Student Y: “If a particle with positive charge $+2Q$ is placed at the bottom-right vertex, the magnitude of the electric field will be zero at Point P.”</p> <p>Student Z: “To make the value of the electric potential zero at Point P, a particle with negative charge $-Q$ should be placed at the bottom-right vertex.”</p> <p>Evaluate the accuracy of each student’s statement. If any aspect of either student’s statement is incorrect, explain how to correct the student’s statement. Support your evaluations using appropriate physics principles.</p> <p>Have students identify, with their peers, adequate claims, evidence, and reasoning. After discussing their various claims, have students return to their desks and develop a complete argument.</p>
<p>Four-Square Problem Solving</p>	<p>Students are given a scenario, perhaps one that came from a traditional, “plug-and-chug” calculation problem. They divide a sheet of paper into four quadrants. In each quadrant, students put some representation of what is going on in the problem. (e.g., motion maps or graphs, any other kinds of graphs, free-body diagrams, energy bar graphs, momentum bar graphs, mathematical models [i.e., equations with symbols], well-labeled diagrams, or written explanations [i.e., two to three strong, clear sentences]).</p>	<p>As they study circuits, have students do four-square problem-solving tasks. The key representations can include a circuit diagram, a circuit sketch, an energy bar chart, or a graph of potential around the circuit.</p>

continued on next page

Strategy	Description	Example
Graph and Switch	Each student in a pair generates a graph (or sketch of a graph), on a graphing calculator or on paper, to model a certain function. Then, the students switch graphing calculators or papers to review each other's solutions.	As students learn about PV graphs, they can graph pressure versus volume for different processes (isobaric, isovolumetric, adiabatic, and isothermal). Have students individually graph and explain how their graphs support specific claims. After, have them share their steps with a partner and exchange feedback on their graphs, claims, evidence, and reasoning.
Marking the Text	Students highlight, underline, and/or annotate a text to identify and focus on key information that helps them understand the concepts and interpretations of tasks required to solve the problem.	Have students read through an AP-level question on experimental design—or have them look at another student's experimental design—and underline the objects, equipment, key information (e.g., the electron is released from rest), and so on, to identify important details needed to answer the question or improve a given response. Leave time for students to ask clarifying questions about words or phrases they find unclear before asking them to provide a solution.
Meaningful, Meaningless Calculations	Students must decide whether a calculation is meaningful (i.e., it gives a value that tells us something legitimate about the physical situation) or is meaningless (i.e., the expression is a totally inappropriate use of a relation). For example, a meaningless calculation might involve substituting a wrong numerical value into an expression.	To illustrate common misconceptions, have students explain whether using the voltage of a battery (instead of the voltage across an individual resistor) is meaningful when calculating current in an individual resistor. Present students with a situation in which there is a uniform magnetic field of specified magnitude, directed toward the left, with an electron traveling parallel to the field at a speed of 300 m/s. Have students find the magnetic force acting on the electron as the product of the speed, the charge, and the magnitude of the field. Ask students if this a meaningful (or meaningless) calculation for this situation.
Note-Taking	Students create a record of information while reading a text, listening to a speaker, or interacting with a problem.	Have students create an AP Physics 2 vocabulary list. Included with each key term (i.e., isobaric) should be a definition, at least one representation (i.e., a PV diagram), the equations that relate to that term, and a brief summary of what kinds of scenarios would require this information (i.e., a thermodynamics problem and not an optics problem).
Predict and Explain	Students predict what will happen in a situation and explain why they think that outcome will occur.	When a circuit is set up with a capacitor, bulb, and switch, ask students: "What will happen to the brightness of the bulb when the switch is closed or opened? What happens immediately versus what happens after a long time? What would happen if the capacitor were replaced with a second bulb?" Students should make a prediction to answer each question and explain why they think that result would occur.

continued on next page

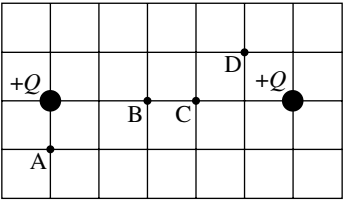
Strategy	Description	Example
Qualitative Reasoning	Students are presented with an initial and a final version of the same physical situation and asked to apply a principle to qualitatively reason how some quantity, or aspect, will change.	Ask students what would happen to the image created by a convex lens if the object were moved farther from or closer to the lens or focal point. To continue their thinking, you may ask students: "What happens if a second lens is added?" or "What would happen to the image if the whole experiment were put under water?" Students should be able to make predictions using functional dependence arguments and support their claim with evidence.
Quickwrite	Students write for a short, specific amount of time about a designated topic.	To help synthesize concepts after having learned how to analyze single- and double-slit experiments, have students list as many ways as possible to change the interference pattern on the screen and explain how each change affects the pattern.
Ranking Tasks	Students are presented with a series of variations of a situation, based on a specific scenario. The variations differ in the values (numeric or symbolic) for the variables involved, but also frequently include variables that are not important to the task. Students must rank the variations of a specified physical quantity and must also explain the reasoning for their ranking choices, as well as rate their confidence in their ranking.	<p>Given the following diagram, have students rank the electric field strength at points A–D. Students must justify their claims with evidence.</p> <p>Two identical charges are fixed to a grid at the locations shown. Four points in the region near the two charges are labeled A–D.</p> 
Sharing and Responding	Students communicate with each other in pairs or in groups, taking turns proposing a solution to a problem and responding to the solutions of others.	Have students individually answer the "conducting loop" question (2018 released exam #1). Then have students review each other's work for the same problem in pairs or small groups. Have those pairs or groups make necessary corrections and build a single, complete argument together.
Simplify the Problem	Students use "friendlier" numbers or functions to help solve a problem.	Have students use resistors with resistances that add easily in parallel. Two resistors with resistances of 30 ohms and 60 ohms in parallel add nicely to 20 ohm total resistance for the combination. Then, ask students to repeat their steps with resistances that don't add as easily, while asking them how they would use the "simpler" problem to help them with this second, more complex one.

continued on next page

Strategy	Description	Example
<i>“What, If Anything, Is Wrong?”</i>	Students analyze a statement or diagrammed situation to determine if it is correct. If everything is correct, students explain why the situation/ statement works as described. If something is incorrect, students must identify the error and explain how to correct it.	<p>Have students analyze a ray diagram that may or may not have incorrect rays drawn. If all rays drawn are correct, have students explain why they are correct. If one or more rays drawn are incorrect, have students explain why they are incorrect and how they might correct the error.</p> <p>Give students a sketch of a circuit and a corresponding circuit diagram, and ask them to identify if the diagram matches the sketch and what reasoning they are using to support their answer.</p>
<i>Write and Switch</i>	Students make observations, collect data, or make a claim about a situation and then switch papers with a partner. Each student in the pair gives feedback on the other’s work and then returns the paper.	<p>As students learn about creating an argument, have them draft an initial argument themselves; share their claim, evidence, and reasoning with a partner; and receive feedback on their argument. Give students a scenario such as:</p> <p>“Ultraviolet light shines on two metal plates, Plate A and Plate B. The two plates are made of different metals. Electrons are ejected from each plate because of the light shining on the plate, and the speed of the electrons ejected from Plate A is larger than the speed of the electrons ejected from Plate B. Is the work function of Plate B greater than, smaller than, or the same as the work function of Plate A?”</p>
<i>Working Backward</i>	Students work with the reverse order of the steps for solving a problem. For example, the given information could be an equation with specific values for all, or all but one, of the variables. Students then construct a physical situation for which the given equation would apply.	<p>Give students an equation, such as $0 = (9 \text{ V}) - (1 \text{ A})(2 \Omega) - (1 \text{ A})(7 \Omega)$, and ask them to create another representation from this equation, such as a written scenario that this equation could represent, a circuit diagram or a potential difference diagram. Start small by asking students for only one additional representation, and work toward having students create several representations for each scenario.</p>

Developing the Science Practices

Throughout the course, students will develop science practices that are fundamental to the discipline of physics. Students will benefit from multiple opportunities to develop these practices in a scaffolded manner. The tables that follow look at each of the science practices and their associated skills and provide examples of questions with sample activities for incorporating instruction on that skill into the course.

Science Practice 1: Creating Representations

Create representations that depict physical phenomena

When physicists describe and explain complex phenomena, they try to simplify real objects, systems, and processes to make the analysis manageable. These simplifications or models are used to predict how new phenomena will occur. A simple model may treat a system as an object, neglecting the system's internal structure and behavior. More complex models are models of a system of objects, such as a fireworks display or planets orbiting the Sun. A process can be simplified, too. Models can be both conceptual and mathematical. Ohm's law is an example of a mathematical model, while the model of a current as a steady flow of charged particles is a conceptual model. To make a good model, students need to identify a set of the most important characteristics of

a phenomenon or system that may simplify analysis. They then need to create a representation of those characteristics. Examples of representations used to model introductory physics are pictures, force diagrams, graphs, energy bar charts, ray diagrams, and circuit diagrams. Representations help in analyzing phenomena and making predictions and communicating ideas. AP Physics 2 requires students to use, analyze, and/or re-express models and representations of natural or man-made systems.

Students often think that to make a graph, they need to connect the data points, or that the best-fit function is always linear. Thus, it is important that they know how to construct a best-fit curve, even for data that do not fit a linear relationship.

The following table provides examples of questions and instructional activities for strengthening the skill of creating representations:

Science Practice 1: Creating Representations

Skill	Questions to Ask Students	Sample Activities
1.A <i>Create diagrams, tables, charts, or schematics to represent physical situations.</i>	<ul style="list-style-type: none">What kind of model or representation would be appropriate for this physical scenario?What physical characteristics can be modeled or represented for this physical scenario?What features of the representation provide information relevant to the question or problem?	<p>Have students divide their paper into four quarters. In each quarter of the paper, students create a representation of a provided physical situation.</p> <p>For example, have students create four different representations of the following scenario. "Three identical charged objects are brought together so that they are held at rest on the corners of an equilateral triangle. The objects are then released from rest." Representations can include equations, narratives, energy bar charts, free-body diagrams, or sketches of the physical situation.</p>
1.B <i>Create quantitative graphs with appropriate scales and units, including plotting data.</i>	<ul style="list-style-type: none">What data should be plotted?What scale and axis labels should be used? What does an appropriately scaled graph look like?What does a graph need to contain to be considered "correctly labeled"?How should the data be graphed so that the best-fit curve shows a relationship?What do the data on the graph show?Is there a pattern present in the data? How do you know? What does the pattern show about the relationship between quantities?What data would need to be graphed to create a linear relationship?What is the physical meaning of the slope and/or area underneath the linearized graph?What is the physical meaning of the y and/or x intercepts of the linearized graph?	<p>When learning about Snell's law, have students measure the incident angle and refracted angle of beam of light from a laser that is incident on a piece of transparent plastic. Repeat the measurements for various angles of incidence. Have students determine what they should graph so that the data is linear.</p> <p>Have students identify correct graphs by giving them a "What, If Anything, Is Wrong?" task. Ask students to analyze a set of data and a supposed matching graph, and ask them to identify what, if anything, is wrong with the graph. The "wrong" things can be simple at first (e.g., scales not uniform, labels left off) and then can be scaffolded to be more difficult and address student misconceptions later in the course.</p>

continued on next page

Science Practice 1: *Creating Representations*

Skill	Questions to Ask Students	Sample Activities
1.C <i>Create qualitative sketches of graphs that represent features of a model or the behavior of a physical system.</i>	<ul style="list-style-type: none">What are the main functional relationships needed to represent the phenomena?What is the relationship between the two physical quantities?	Ask students to sketch a graph of the radius of curvature of the path of an electron through a magnetic field as a function of the speed of the electron. Then have students add to that sketch a graph of the radius of curvature of the path of a proton through the same magnetic field as a function of the speed of the proton. Finally, have students highlight the differences and similarities of the two graphs.

Science Practice 2: **Mathematical Routines**

Conduct analyses to derive, calculate, estimate, or predict physical phenomena.

Physicists commonly use mathematical representations to describe and explain phenomena, as well as to solve problems. When students work with these representations, they should understand the connections between the mathematical descriptions, the physical phenomena, and the concepts represented in them. When using equations or mathematical representations, students need to be able to justify why using a particular equation to analyze a situation is useful, and be aware of the conditions under which the equation/mathematical representation can be used. When solving a problem, students need to be able to describe the given situation in multiple

ways, including through pictorial representations, force diagrams, and so on, and then choose an appropriate mathematical representation—instead of first choosing a formula whose variables seem to match the “givens” in the problem.

Students should also be able to work with the algebraic form of the equation before substituting values, as well as be able to solve the equation and interpret the answer in terms of units and limiting case analysis. Students should be able to translate between functional relationships in equations (e.g., proportionalities, inverse proportionalities, etc.) and cause-and-effect relationships in the physical world while also being able to evaluate a numerical result in terms of appropriateness for the given context. The following table provides examples of questions and instructional strategies for implementing mathematical routines into the course:

Science Practice 2: Mathematical Routines

Skill	Questions to Ask Students	Sample Activities
2.A <i>Derive a symbolic expression from known quantities by selecting and following a logical mathematical pathway.</i>	<ul style="list-style-type: none">What laws, definitions, or mathematical relationships exist that relate to the given problem?What are the rules, assumptions, or limitations surrounding the use of the chosen law, definition, or relationship?Did the derivation begin with an equation or a fundamental physics relationship, law, or definition? If so, which one?Are the steps clearly written out and annotated? Are any steps skipped? If so, which ones?	<p>Have students identify which main law, definition, or mathematical relationship should be used based solely on question stems of multiple-choice questions, without looking at the question or the response choices. Have students practice thinking about what could be asked of them, and what analysis technique they might want to use just from looking at the prompt they are given to analyze.</p> <p>When deriving an expression for the current in a long rectangular loop of wire being pulled into a magnetic field, have students choose equations (i.e., Faraday's law of induction and Ohm's law) to begin their derivation from the AP Physics 2 equation sheet.</p>
2.B <i>Calculate or estimate an unknown quantity with units from known quantities by selecting and following a logical computational pathway.</i>	<ul style="list-style-type: none">Did the calculation begin with an equation or a fundamental physics relationship, law, or definition? If so, which one?What known quantities can be used to calculate the unknown quantity?What steps should be followed to use the known quantities to calculate the unknown quantity?Is the calculated quantity clearly labeled complete with units?	<p>Have students work backward from a given mathematical routine to a physical situation. For example, students can be given an equation such as</p> $(1.56 \text{ eV}) = \frac{(1240 \text{ eV nm})}{(200 \text{ nm})} - (4.64 \text{ eV})$ <p>and then be asked to create another representation from this equation, such as a written scenario that this equation could represent, a graph of stopping potential as a function of frequency, an energy bar chart for the ejected electrons, or a motion map for the ejected electrons.</p>
2.C <i>Compare physical quantities between two or more scenarios or at different times and/or locations within a single scenario.</i>	<ul style="list-style-type: none">What relationship(s) link the needed and given quantities?Can the relationship between the quantities be rewritten so that the variable in question is alone on one side of the equation?What symbols in the relationship are constants versus variables that can change?How should you label the calculated quantity? What units should be used?	<p>Give students a scenario where a gas in a container is compressed at a constant pressure, and the work done is W_1. The gas is then brought to the same original state and compressed again so that the final volume is smaller than before and the work done is W_2. Is W_2 greater than, less than or equal to W_1? Have students analyze the relationships between pressure, volume, and work to justify their answer to this question.</p>

continued on next page

Science Practice 2: Mathematical Routines

Skill	Questions to Ask Students	Sample Activities
2.D <i>Predict new values or factors of change of physical quantities using functional dependence between variables.</i>	<ul style="list-style-type: none">What relationship(s) link(s) the needed and given quantities?What are the rules, assumptions, or limitations surrounding the use of the chosen law, definition, or relationship?How are the quantities in the relationship related (e.g., directly, inversely, etc.)?	When analyzing a circuit with capacitors and a battery, have students quantitatively and qualitatively estimate, and then determine the changes in the energy stored in the capacitors depending on whether the capacitors are arranged in series or parallel.

Science Practice 3: Scientific Questioning and Argumentation

Describe experimental procedures, analyze data, and support claims.

Physicists examine data and evidence to develop claims about physical phenomena. As they articulate their claims, physicists use reasoning processes that rely on their awareness of different types of relationships, connections, and patterns within the data and evidence. They then formulate a claim and develop an argument that explains how the claim is supported by the available evidence. As a result, students should learn how to create persuasive and meaningful arguments by using claims they develop and evidence they've identified to support those claims. Scientific questions can range in scope, as well as in specificity, from determining influencing factors to determining mechanisms. The question posed will determine the type of data to be collected and will influence the plan for collecting data. Designing and improving experimental designs and/or data-collection strategies is a learned skill. Class discussions can reveal issues of measurement uncertainty and assumptions in data collection. Although detailed error analysis is not necessary for the AP Physics 2 Exam, it is important

that students make some reasoned estimate of the percent error or percent difference where appropriate and are able to make claims about sources of uncertainty and error and how each source contributes to the error.

Being able to devise testable explanations goes hand-in-hand with dealing with new phenomena. It is important that students understand that scientific instruments do not produce exact measurements and learn what steps they can take to decrease uncertainty. One step may be designing a second experiment to determine the same quantity and then checking for consistency across the two measurements. Finally, students should be able to revise their initial explanation or reasoning based on the new data.

The analysis, interpretation, and application of quantitative information are vital skills for students in AP Physics 2. Analysis skills can be taught using any type of data, but students will be more invested in their data analysis if it is data they have collected through their own investigations. Students should be encouraged to analyze their data, draw conclusions, and apply their knowledge to content across the course.

The following table provides examples of strategies for implementing argumentation resources into the course:

Science Practice 3: Scientific Questioning and Argumentation

Skill	Questions to Ask Students	Sample Activities
3.A <i>Create experimental procedures that are appropriate for a given scientific question.</i>	<ul style="list-style-type: none">What information will be needed to answer the scientific question? What data should be collected?What equipment is needed to collect the necessary data?How will each piece of equipment be used to collect the necessary data?What possible errors need to be addressed before data collection?What steps can be taken to decrease the uncertainty in the measurements and data?What changes can be made to observations and measurements to refine the data?How will the data be analyzed to answer the scientific question?How can a second experiment be designed to answer the same scientific question and check for consistency?	<p>Have students design an experiment and analyze graphical data where the area under a curve is needed to determine the work done on or by the object or system.</p> <p>Have students list the common sources of uncertainty and error in an experiment to find the resistance of an unknown resistor. Then, have them identify and/or describe the manner in which each source would affect the results of the experiment.</p>
3.B <i>Apply an appropriate law, definition, theoretical relationship, or model to make a claim.</i>	<ul style="list-style-type: none">What law, definition, relationship, or model can be used to make a claim about the scenario?What is your purpose (e.g., to define, show causality, compare, or explain a process) for making a claim?	<p>Ask students a question such as, “What factors affect the speed of a photoelectron ejected from the surface of a metal when light is directed onto a metal?”</p>
3.C <i>Justify or support a claim using evidence from experimental data, physical representations, or physical principles or laws.</i>	<ul style="list-style-type: none">What reasoning (e.g., physical laws theories) supports your claim?How does the reasoning support your claim?How does the evidence support your claim?	<p>Give students the following scenario:</p> <p>“A beam of coherent light of wavelength λ is incident perpendicularly onto a pair of slits. Each slit has width w, and the centers of the slits are a distance d apart. There is a screen a distance L between the slits and a screen.”</p> <p>Ask students to explain why some of the spots on the screen that <i>should</i> be bright (interference maximums) are not. Have them support their claim with reasoning and evidence.</p>

Practicing with Science Practices and Skills:

CASE STUDY—THIN LENS

The following multiple-choice questions (MCQs) all use the same stimulus and basic scenario. However, each MCQ is written to assess the various skills described above. This case study helps illustrate how the same content can be tested in different ways depending on what science practice it is paired with. The more opportunities that students have to practice content with different science practices, the stronger and better prepared they will be for the AP Physics 2 Exam. The content below is appropriate for AP Physics 2. (Science Practice 1 is FRQ only, and is not represented below.)

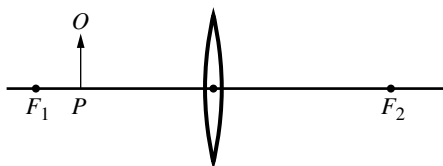

An object O is located at point P to the left of a converging lens, as shown in the figure. F_1 and F_2 are the focal points of the lens.

Skill 2.A—Derivations

Derive a symbolic expression from known quantities by selecting and following a logical mathematical pathway.

QUESTION 2.A:

Point P is a distance d_o from the lens, and the focal length of the lens is f . Which of the following is an expression for the magnification of the image?

- (A) $\frac{f}{d_o - f}$
- (B) $\frac{d_o - f}{f}$
- (C) $\frac{fd_o}{d_o - f}$
- (D) $\frac{d_o - f}{fd_o}$

Skill 2.B—Calculations

Calculate or estimate an unknown quantity with units from known quantities by selecting and following a logical computational pathway.

QUESTION 2.B:

If the focal length of the lens is 0.40 m and point P is 0.30 m to the left of the lens, where is the image of the object located?

- (A) 1.2 m to the left of the lens
- (B) 0.17 m to the left of the lens
- (C) 0.17 m to the right of the lens
- (D) 1.2 m to the right of the lens

Skill 2.C—Comparisons

Compare physical quantities between two or more scenarios or at different times and/or locations within a single scenario.

QUESTION 2.C:

The height of the image, when the object is at point P is H . If the object is moved closer to the lens, how does the new height of the image H_2 compare to H ?

- (A) $H > H_2$
- (B) $H < H_2$
- (C) $H = H_2$
- (D) H and H_2 cannot be compared without knowing the focal length of the lens.

Skill 2.D—Functional Dependence

Predict new values or factors of change of physical quantities using functional dependence between variables.

QUESTION 2.D:

Students move the object to various positions to the left of F_1 and record the image distance and the object distance for each position of the object. Students graph the inverse of the image distance on the vertical axis and the inverse of the object distance on the horizontal axis. Which of the following describes how students can determine a value for the focal length of the lens with their graph?

- (A) The focal length is the slope of the graph.
- (B) The focal length is the inverse of the slope of the graph.
- (C) The focal length is the area bound by the line of best fit and the horizontal axis.
- (D) The focal length is the vertical intercept.

Skill 3.B—Make a Claim

Apply an appropriate law, definition, theoretical relationship, or model to make a claim.

QUESTION 3.B:

Which of the following characterizes the image when the object is at point P?

- (A) Real, inverted, and smaller than the object
- (B) Real, upright, and larger than the object
- (C) Virtual, upright, and larger than the object
- (D) Virtual, upright, and smaller than the object

Skill 3.C—Justify a Claim

Justify or support a claim using evidence from experimental data, physical representations, or physical principles or laws.

QUESTION 3.C:

For the setup above where the object distance is less than the focal length of the lens, which of the following correctly explains why the image is virtual?

- (A) The light rays originating from the tip of the object are refracted so that they intersect at another common point.
- (B) The light rays originating from the tip of the object are refracted so that they diverge such that they appear to have originated from a common point.
- (C) The light rays originating from the tip of the object are reflected beyond a critical angle of incidence.
- (D) The light rays originating from the tip of the object are reflected and diverge as if they originated from a focal point on the incident side of the lens.

THIS PAGE IS INTENTIONALLY LEFT BLANK.

AP PHYSICS 2

Exam Information



Exam Overview

The AP Physics 2 exam assesses student application of the science practices and understanding of the learning objectives outlined in the course framework. The exam is 3 hours long and includes 40 multiple-choice questions and 4 free-response questions. A four-function scientific, or graphing calculator is allowed on both sections of the exam. The details of the exam, including exam weighting and timing, can be found below:

Section	Type of Questions	Number of Questions	Weighting	Timing
I	Multiple-choice questions	40	50%	80 minutes
II	Free-response questions	4	50%	100 minutes
	Question 1: Mathematical Routines			
	Question 2: Translation Between Representations			
	Question 3: Experimental Design and Analysis			
	Question 4: Qualitative/Quantitative Translation			

The exam also assesses each of the seven units of instruction with the following exam weightings on the multiple-choice section of the AP Exam:

Exam Weighting for the Multiple-Choice Section of the AP Exam

Units of Instruction	Exam Weighting
Unit 9: Thermodynamics	15–18%
Unit 10: Electric Force, Field, and Potential	15–18%
Unit 11: Electric Circuits	15–18%
Unit 12: Magnetism and Electromagnetism	12–15%
Unit 13: Geometric Optics	12–15%
Unit 14: Waves, Sound, and Physical Optics	12–15%
Unit 15: Modern Physics	12–15%

How Student Learning Is Assessed on the AP Exam

Exam Weighting by Science Practice

Science Practices 2 and 3 are assessed in the multiple-choice section with the following weighting (Science Practice 1 will not be assessed in the multiple-choice section). Science Practices 1, 2 and 3 are all assessed in the free-response section with the following weighting.

Please note: Required course content (Learning Objectives and Essential Knowledge) can be assessed with any skill.

Science Practice	Approximate MCQ Exam Weighting	Approximate FR Exam Weighting
1.A Create diagrams, tables, charts, or schematics to represent physical situations.	N/A	
1.B Create quantitative graphs with appropriate scales and units, including plotting data.	N/A	20–35%
1.C Create qualitative sketches of graphs that represent features of a model or the behavior of a physical system.	N/A	
2.A Derive a symbolic expression from known quantities by selecting and following a logical mathematical pathway.	15–20%	
2.B Calculate or estimate an unknown quantity with units from known quantities, by selecting and following a logical computational pathway.	20–25%	30–40%
2.C Compare physical quantities between two or more scenarios or at different times and locations in a single scenario.	10–15%	
2.D Predict new values or factors of change of physical quantities using functional dependence between variables.	10–15%	

continued on next page

Science Practice	Approximate MCQ Exam Weighting	Approximate FR Exam Weighting
3.A Create experimental procedures that are appropriate for a given scientific question.	N/A	
3.B Apply an appropriate law, definition, theoretical relationship, or model to make a claim.	20–25%	35–45%
3.C Justify or support a claim using evidence from experimental data, physical representations, or physical principles or laws.	5–10%	

Free-Response Questions

The free-response section of the AP Physics 2 Exam consists of four question types listed below. Each question type appears on the exam.

Mathematical Routines (MR)

Skills: **1.A** **1.C** **2.A** **2.B** **3.B** **3.C**

10 points; suggested time: 20–25 minutes

The Mathematical Routines (MR) question assesses students' ability to use mathematics to analyze a scenario and make predictions about that scenario. Students will be expected to symbolically derive relationships between variables, as well as calculate numerical values. Students will be expected to create and use representations that describe the scenario, either to help guide the mathematical analysis (such as drawing a free-body diagram) or that are applicable to the scenario (such as sketching velocity as a function of time).

For AP Physics 1 and AP Physics 2, the MR question will ask students to make a claim or prediction about the scenario and use appropriate physics concepts and principles to support and justify that claim. The justification is expected to be a logical and sequential application of physics concepts that demonstrates a student's ability to connect multiple concepts to each other.

Translation Between Representations (TBR)

Skills: **1.A** **1.C** **2.A** **2.D** **3.B** **3.C**

12 points; suggested time: 25–30 minutes

The Translation Between Representations (TBR) question assesses students' ability to connect different representations of a scenario. Students will be expected to create a visual representation that describes a given scenario. Students will derive equations that are mathematically relevant to the scenario. Students will draw graphs that relate quantities within the scenario. Finally, students will be asked to do any one of the following:

- Justify why their answers to any two of the previous parts do/do not agree with each other.
- Use their representations, mathematical analysis, or graph to make a prediction about another situation and justify their prediction using that reasoning or analysis.
- Use their representations, mathematical analysis, or graph to make a prediction about how those representations would change if properties of the scenario were altered and justify that claim using consistent reasoning or analysis.

Experimental Design and Analysis (LAB)

Skills: **1.B** **2.B** **2.D** **3.A** **3.B**

10 points; suggested time: 25–30 minutes

The Experimental Design and Analysis (LAB) question assesses students' ability to create scientific procedures that can be used with appropriate data analysis techniques to determine the answer to given questions. The LAB question can roughly be divided into two sections: Design and Analysis. In the Design portion of the LAB question, students will be asked to develop a method by which a question about a given physical scenario could be answered. The experimental procedure is expected to be scientifically sound: vary a single parameter, and measure how that change affects a single characteristic. Methods must be able to be performed in a typical high school laboratory. Measurements must be made with realistically obtainable equipment or sensors. Students will be expected to describe a method by which the collected data could be analyzed in order to answer the posed question, by either graphical or comparative analyses.

Students will then be given experimental data collected in order to answer a similar, but not identical, question to what was asked in the Design portion of the question. Students will be asked to use the data provided to create and plot a graph that can be analyzed to determine the answer to the given question. For instance, the slope or intercepts of the line may be used to determine a physical quantity or perhaps the nature of the slope would answer the posed question.

Qualitative/Quantitative Translation (QQT)

Skills: **2.A** **2.D** **3.B** **3.C**

8 points; suggested time: 15–20 minutes

The Qualitative/Quantitative Translation (QQT) question assesses students' ability to connect the nature of the scenario, the physical laws that govern the scenario, and mathematical representations of that scenario to each other. Students will be asked to make and justify a claim about a given scenario, as well as derive an equation related to that scenario. Finally, students will be asked to do any one of the following:

- Justify why their answers to any of the previous parts do/do not agree with each other.
- Use their representations or mathematical analysis to make a prediction about another situation and justify their prediction using that reasoning or analysis.
- Use their representations and mathematical analysis to make a prediction about how those representations would change if properties of the scenario were altered and justify that claim using consistent reasoning or analysis.

While students may not be directly assessed on their ability to create diagrams or other representations of the system to answer the QQT, those skills may still help students to answer the QQT. For instance, some students may find that drawing a free-body diagram is useful when determining the acceleration of a system. However, the student will earn points for the explanation and conclusions that diagram indicates (or perhaps the derivation that results from the diagram), rather than for creating the diagram itself.

Task Verbs Used in Free-Response Questions

The following task verbs are commonly used in the free-response questions.

Calculate: Perform mathematical steps to arrive at a final answer, including algebraic expressions, properly substituted numbers, and correct labeling of units and significant figures.

Compare: Provide a description or explanation of similarities and/or differences.

Derive: Starting with a fundamental law or relationship, perform a series of mathematical steps to arrive at a final answer.

Describe: Provide the relevant characteristics of a specified topic.

Determine: Make a decision or arrive at a conclusion after reasoning, observation, or applying mathematical routines (calculations).

Draw: Create a diagram or schematic that illustrates relationships, depicts physical objects, or demonstrates consistency between different types of representation. Labels may or may not be required.

Estimate: Roughly calculate numerical quantities, values (greater than, equal to, less than), or signs (negative, positive) of quantities based on experimental evidence or provided data. When making estimations, showing steps in calculations are not required.

Indicate: Provide information about a specified topic, without elaboration or explanation.

Justify: Provide qualitative reasoning beyond mathematical derivations or expressions to support, qualify, or defend a claim.

Label: Provide labels indicating unit, scale, and/or components in a diagram, graph, model, or representation.

Plot: Draw data points in a graph using a given scale or indicating the scale and units, demonstrating consistency between different types of representations.

Rank: Arrange quantities in relation to each other, typically by size or magnitude.

Sketch: Create a graph, representation, or model that illustrates relationships or phenomena, demonstrating consistency between different types of representations. Labels may or may not be required.

Verify: Confirm that the conditions of a scientific definition, law, theorem, or test are met to explain why it applies in a given situation. Also, use empirical data, observations, tests, or experiments to prove, confirm, and/or justify a hypothesis.

Sample Exam Questions

The sample exam questions that follow illustrate the relationship between the course framework and the AP Physics 2 Exam and serve as examples of the types of questions that appear on the exam. These sample questions do not represent the full range and distribution of items on an official AP Physics 2 Exam. After the sample questions is a table which shows which skill, learning objective, and essential knowledge statement each question relates to. This table also provides the answers to the multiple-choice questions.

Section I: Multiple-Choice Questions

1. The root-mean-square speed of the atoms of a monatomic ideal gas at a temperature of 200 K is v_{rms} . At a later time, the root-mean-square speed of the atoms is $2v_{\text{rms}}$. What is the temperature of the gas at this later time?
(A) 800 K
(B) 400 K
(C) 200 K
(D) 50 K

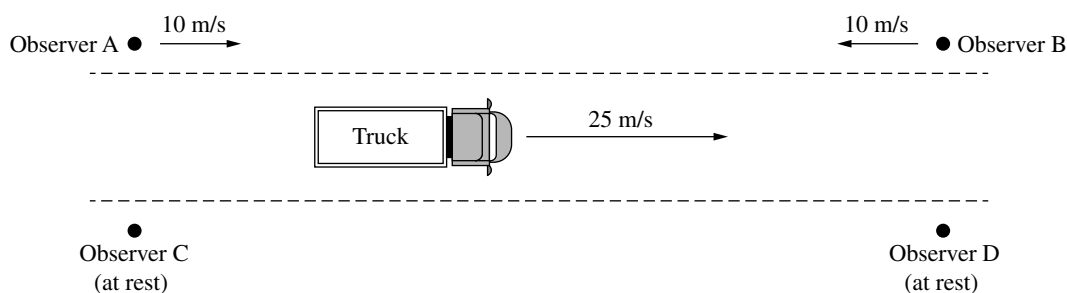

2. A truck is traveling to the east with a speed of 25 m/s relative to the road while emitting a loud sound with a single frequency. The figure shows four different observers and indicates their locations and velocities relative to the road. Which observer hears a sound with the highest frequency?
(A) A
(B) B
(C) C
(D) D

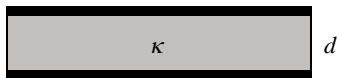

Capacitor 1

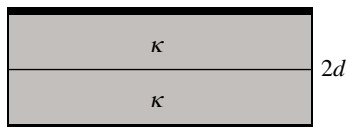

Capacitor 2

3. The figures show two different capacitors made of identical parallel conducting plates. In Capacitor 1, the plates are separated by a distance d and a block of material with dielectric constant κ is inserted between the plates. In Capacitor 2, the plates are separated by a distance $2d$ and two identical blocks of material with dielectric constant κ are inserted between the plates. A student claims that the capacitance of Capacitor 2 is the same as that of Capacitor 1. Which of the following indicates whether the claim is correct or incorrect, and provides a valid justification?

- (A) Correct, because the effects of doubling the distance between the plates and doubling the volume of the dielectric cancel each other.
- (B) Correct, because the capacitance is a property of the plates and the plates have not changed.
- (C) Incorrect, because doubling the thickness of the dielectric material will cause the capacitance to double.
- (D) Incorrect, because doubling the distance between the plates will reduce the capacitance by half.

4. At time $t=0$, a sample of radioactive material with decay constant λ has N_0 nuclei. At time $t=t_1$, there are N_1 nuclei remaining. At a later time $t=t_2$, there are N_2 nuclei remaining. Which of the following correctly relates N_2 to N_1 ?

- (A) $N_2 = N_1 e^{-\lambda(t_2-t_1)}$
- (B) $N_2 = N_1 e^{-\lambda(t_2+t_1)}$
- (C) $N_2 = \frac{N_1}{N_0} e^{-\lambda(t_2-t_1)}$
- (D) $N_2 = \frac{N_1}{N_0} e^{-\lambda(t_2+t_1)}$

5. A student places a lens 40 cm from an object and observes an enlarged image on a screen on the opposite side of the lens. Which of the following could be the type of lens and the focal length of the lens?
- (A) A diverging lens with a focal length of 30 cm
 (B) A diverging lens with a focal length of 50 cm
 (C) A converging lens with a focal length of 30 cm
 (D) A converging lens with a focal length of 50 cm

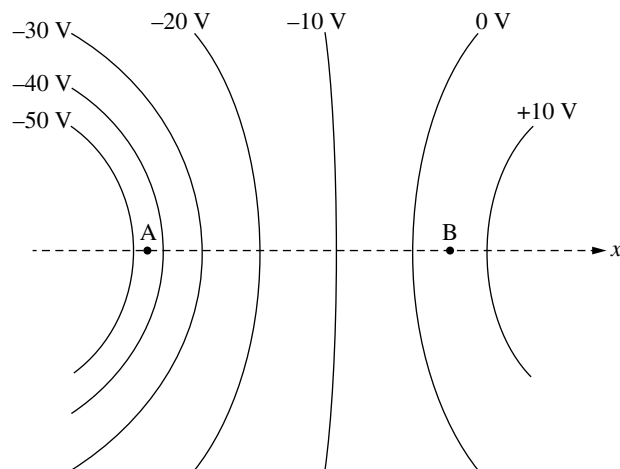

6. The figure shows equipotential lines in a particular region. The value of the potential along each line is indicated. Two points, A and B, lie along the x -axis. The electric field at Point A is \vec{E}_A and the electric field at Point B is \vec{E}_B . Which of the following correctly compares the magnitudes of \vec{E}_A and \vec{E}_B , and indicates whether the vectors are in the same or opposite direction?

	Magnitudes	Directions
A	$E_A < E_B$	Same direction
B	$E_A < E_B$	Opposite directions
C	$E_A > E_B$	Same direction
D	$E_A > E_B$	Opposite directions

- (A) A
 (B) B
 (C) C
 (D) D

Questions 7 and 8 refer to the following.

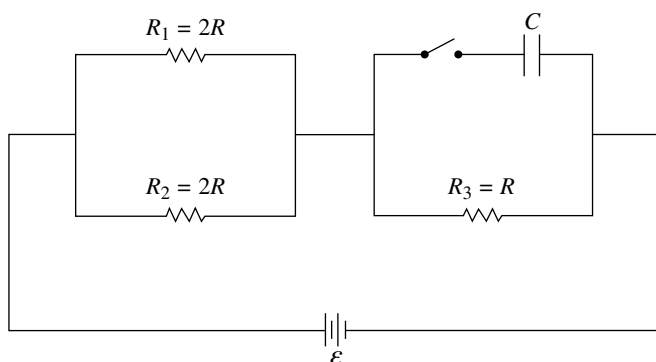

The circuit shown consists of an ideal battery of emf \mathcal{E} , three resistors with the resistances indicated, a capacitor of capacitance C , and a switch. The capacitor is initially uncharged and the switch is initially open.

7. When the switch is open, which of the following correctly compares the powers P_1 , P_2 , and P_3 dissipated by the resistors with resistances R_1 , R_2 , and R_3 , respectively?
- (A) $P_1 = P_2 = P_3$
- (B) $P_3 > (P_1 = P_2)$
- (C) $(P_1 = P_2) > P_3 > 0$
- (D) $(P_1 = P_2) > (P_3 = 0)$
8. The switch is closed at time $t = t_1$. A long time later, at $t = t_2$, the circuit reaches steady state conditions. Which of the following correctly indicates how the current I_s in the switch and the magnitude of the potential difference $|\Delta V_C|$ across the capacitor change between t_1 and t_2 ?

	I_s	$ \Delta V_C $
A	Increases	Increases
B	Increases	Decreases
C	Decreases	Increases
D	Decreases	Decreases

- (A) A
- (B) B
- (C) C
- (D) D

9. A 0.050 kg piece of an unknown metal is initially at a temperature of 373 K. The metal is then quickly moved into an insulated container with 0.100 kg of water at a temperature of 295 K. The water and the metal come to equilibrium at a temperature of 300 K. The specific heat of water is $4184 \text{ J}/(\text{kg} \cdot \text{K})$. What is the specific heat of the unknown metal?
- (A) $287 \text{ J}/(\text{kg} \cdot \text{K})$
 (B) $573 \text{ J}/(\text{kg} \cdot \text{K})$
 (C) $2090 \text{ J}/(\text{kg} \cdot \text{K})$
 (D) $6620 \text{ J}/(\text{kg} \cdot \text{K})$

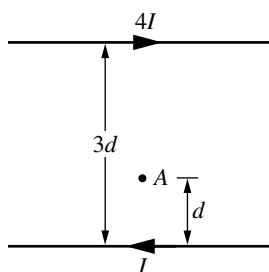

10. Two long parallel wires, each in the plane of the page, are separated by a distance $3d$, as shown. The top wire carries current $4I$ directed to the right, and the bottom wire carries current I directed to the left. Point A is also in the plane of the page, located a distance d above the bottom wire. Which of the following correctly represents the magnitude of the magnetic field due to the wires at Point A?
- (A) $\frac{1}{2} \frac{\mu_0 I}{\pi d}$
 (B) $\frac{3}{4} \frac{\mu_0 I}{\pi d}$
 (C) $\frac{3}{2} \frac{\mu_0 I}{\pi d}$
 (D) $\frac{5}{2} \frac{\mu_0 I}{\pi d}$

11. A blackbody of temperature T_0 emits a spectrum of light with a peak wavelength λ_0 . The rate at which energy is emitted by the blackbody is P_0 . The temperature of the blackbody is then changed so that the new peak wavelength emitted by the blackbody is $\frac{\lambda_0}{2}$. Which of the following correctly indicates the rate at which energy is emitted by the blackbody at this new temperature?
- (A) $\frac{P_0}{2}$
- (B) $\frac{P_0}{16}$
- (C) $2P_0$
- (D) $16P_0$

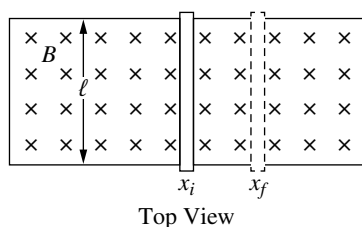

12. A metal bar of mass M and resistance R is pushed to the right at a constant speed along two horizontal, parallel, conducting rails, as shown in the top view diagram. The rails are separated by a distance ℓ , and are connected at the left end by a wire. The rails and wire have negligible resistance. The entire apparatus is in a uniform magnetic field of magnitude B that is directed into the page. At time t_i the bar is at position x_i , and a short time later at time t_f the bar is at position x_f . Which of the following expressions is equal to the average force exerted on the bar by the magnetic field between t_i and t_f ?

- (A) $\frac{\ell B}{R} \left(\frac{x_f - x_i}{t_f - t_i} \right)$
- (B) $\frac{\ell^2 B^2}{R} \left(\frac{x_f - x_i}{t_f - t_i} \right)$
- (C) $\frac{x_i B}{R} \left(\frac{x_f - x_i}{t_f - t_i} \right)$
- (D) $\frac{x_i \ell B^2}{R} \left(\frac{x_f - x_i}{t_f - t_i} \right)$

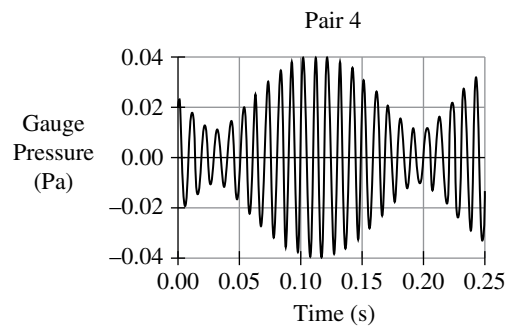
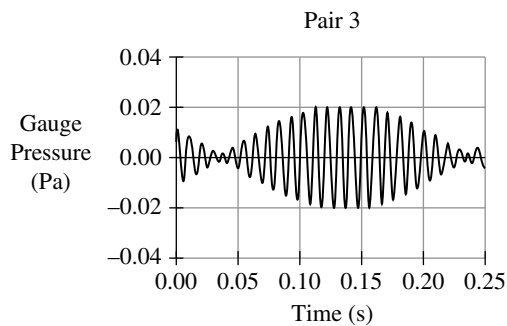
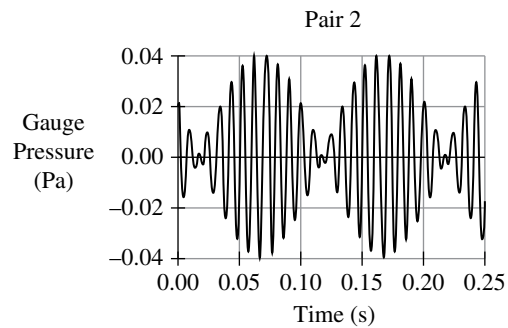
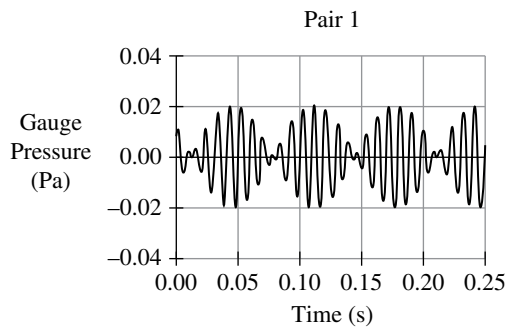

13. Pairs of tuning forks are struck near a microphone, which is connected to a computer that creates graphs of the resulting gauge pressure (the difference between the pressure and atmospheric pressure) as functions of time. The figure shows graphs for four pairs of tuning forks, where each pair consists of tuning forks that vibrate at different frequencies. Which pair of tuning forks has the greatest difference in frequencies?

- (A) Pair 1
- (B) Pair 2
- (C) Pair 3
- (D) Pair 4

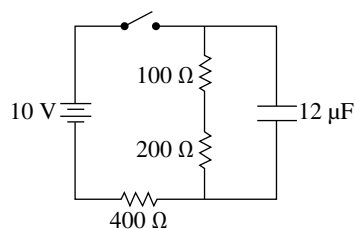

14. A 10 V battery, resistors with resistances of $100\ \Omega$, $200\ \Omega$, and $400\ \Omega$, a $12\ \mu\text{F}$ capacitor, and a switch are connected as shown. The capacitor is initially uncharged and the switch is initially open. What is the current in the battery immediately after the switch is closed?
- (A) Zero
 (B) 14 mA
 (C) 25 mA
 (D) 33 mA

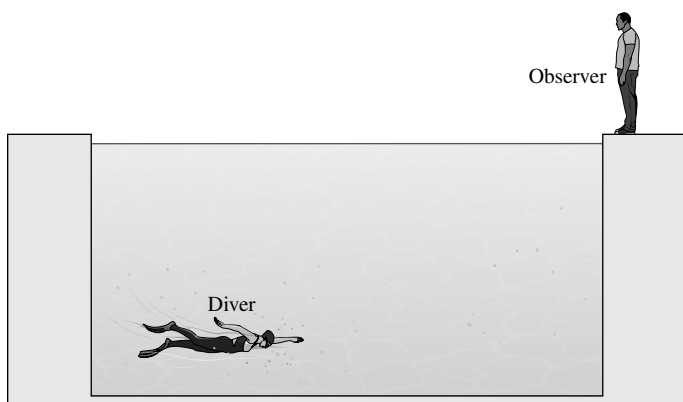

15. A diver is swimming underwater in a pool filled with water. An observer is standing at the edge of the pool, as shown. Will the observer always be able to see the diver no matter where the diver is in the pool? Why or why not?
- (A) Yes, because light originating from the diver will always refract away from the normal and toward the observer.
 (B) Yes, because for every position of the diver, there is a straight-line path connecting the diver and the observer.
 (C) No, because light passing from a medium with high index of refraction to low index of refraction will always totally reflect at the boundary between the two media.
 (D) No, because for some positions of the diver the light from the diver will totally reflect at the water-air boundary.

Section II: Free-Response Questions

FREE-RESPONSE QUESTION: MATHEMATICAL ROUTINES

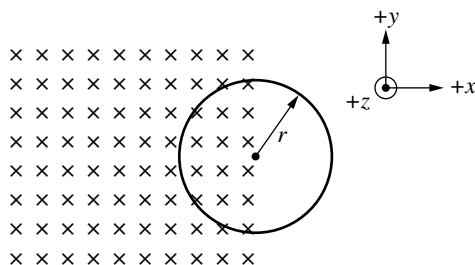

Figure 1

1. A circular conducting loop of radius r is held at rest in the xy -plane, as shown in Figure 1. The resistance of the loop is R . Half of the loop is in a region with a uniform magnetic field of magnitude B_0 that is directed into the page ($-z$ -direction). During a time interval Δt , the magnitude of the magnetic field is increased at a constant rate from B_0 to $4B_0$.
 - (a) Express your answers for (a)(i) and (a)(ii) in terms of r , R , B_0 , Δt , and physical constants, as appropriate.
 - i. **Derive** an expression for the emf \mathcal{E} induced in the loop during the interval Δt .
 - ii. **Derive** an expression for the total energy dissipated by the loop during the interval Δt .

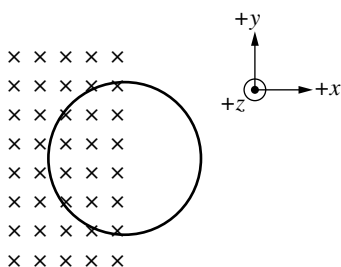

Figure 2

- iii. Complete the following tasks on Figure 2:
 - **Draw** an arrow labeled I to indicate the direction of the current in the loop during the interval Δt .
 - **Draw** an arrow labeled F to indicate the direction of the net magnetic force exerted on the loop during the interval Δt .

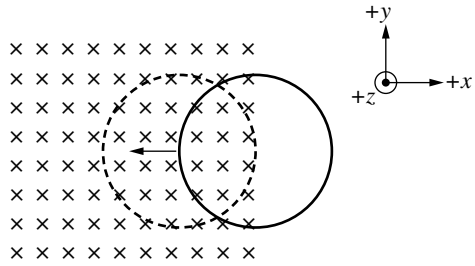

Figure 3

The magnitude of the magnetic field is now held constant while the loop is pulled in the $-x$ -direction by an external force until the loop is completely inside the region with the magnetic field, as indicated by the dashed line in Figure 3.

- (b) On both blanks below, **write** “yes” or “no” to indicate whether an emf is induced in the loop when the loop is partially in the region with the magnetic field and when the loop is completely in the region.

_____ When the loop is partially in the region

_____ When the loop is completely in the region

Justify your answers using physics principles.

FREE-RESPONSE QUESTION: TRANSLATION BETWEEN REPRESENTATIONS

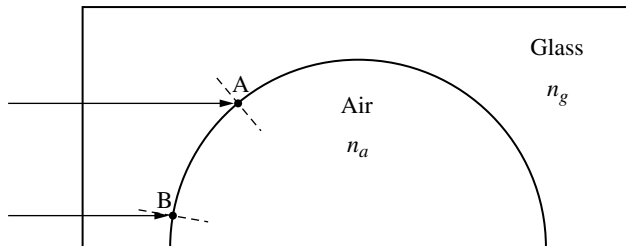

Figure 1

2. A glass block has a semicircular section removed, as shown in Figure 1. The air has an index of refraction $n_a = 1$ and the glass has an index of refraction $n_g > 1$. Two rays of monochromatic light of frequency f_0 travel parallel to each other in the glass block and are incident on the glass-air boundary at points A and B, as shown. Both rays refract at the glass-air boundary.

- (a) On the diagram of the block in Figure 2 below, **sketch** the paths of the rays in the air after the rays exit the glass at points A and B.

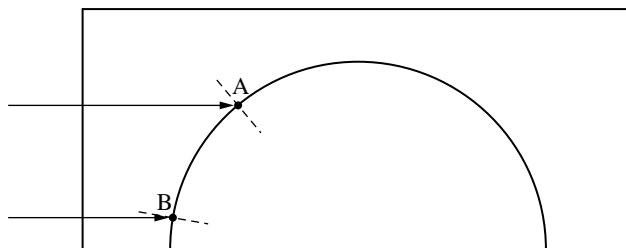

Figure 2

- (b) **Derive** an equation for the change in wavelength $\Delta\lambda$ of the light when it passes from the glass into the air. Express your answer in terms of f_0 , n_g , and fundamental constants, as appropriate.

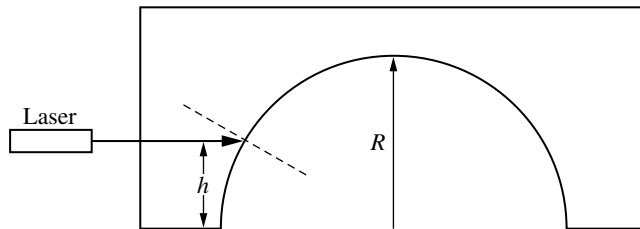

Figure 3

- (c) A laser is used to shine a horizontal beam of light on the glass block, as shown in Figure 3. The height h of the beam is varied and the angle θ_r of the refracted beam to the normal is measured for several values of h , and the value of $\sin\theta_r$ is calculated.

On the axes below in Figure 4, **sketch** $\sin\theta_r$ as a function of h .

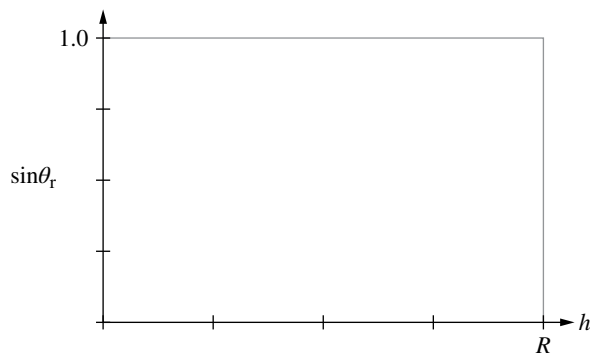
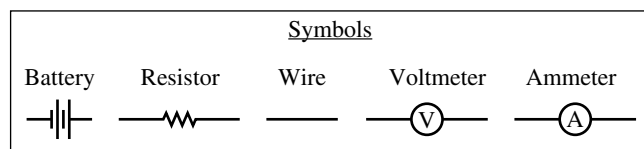

Figure 4

- (d) **Indicate** whether the sketch drawn in part (c) is consistent with the rays drawn in part (a). Briefly **justify** your response.

FREE-RESPONSE QUESTION: EXPERIMENTAL DESIGN AND ANALYSIS (LAB)

3. A student is provided with several resistors with different known resistances, an ideal battery, a voltmeter, an ammeter, and connecting wires. The student is given an additional resistive component R_x .
- (a) The student is asked to design an experimental procedure to determine whether R_x is ohmic using the equipment provided.
- i. Using the symbols shown, **draw** a diagram of a circuit that the student could use to determine whether R_x is ohmic, including the appropriate placement of the measurement devices.



- ii. Referring to your diagram, **describe** the overall procedure, providing enough detail so that students could replicate the experiment, including any steps necessary to reduce experimental uncertainty.
- (b) **Describe** how the data collected in part (a) could be graphed and how that graph would be analyzed to determine whether R_x is ohmic.

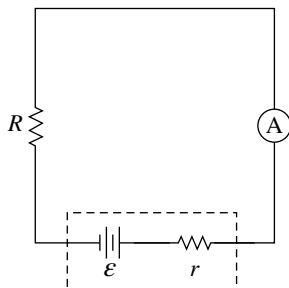

Figure 1

In a different experiment, the student uses the same resistors of known resistance, a battery of emf \mathcal{E} with internal resistance r , and an ammeter connected as shown in Figure 1. The student is asked to determine the internal resistance r of the battery. For each value of the resistance R of the known resistors, the student measures the current in the ammeter. The student's data are represented in the following table.

$R(\Omega)$	$I(\text{mA})$			
10	58			
20	44			
30	31			
40	28			
50	22			
60	19			

- (c) i. **Indicate** two quantities that could be graphed to yield a straight line that could be used to determine the internal resistance r of the battery. Use the blank columns in the table to list any calculated quantities you will graph other than the data provided.

Vertical Axis: _____ Horizontal Axis: _____

- ii. **Plot** the data points for the quantities indicated in part (c)(i) on the graph provided. Clearly scale and label all axes, including units, as appropriate.

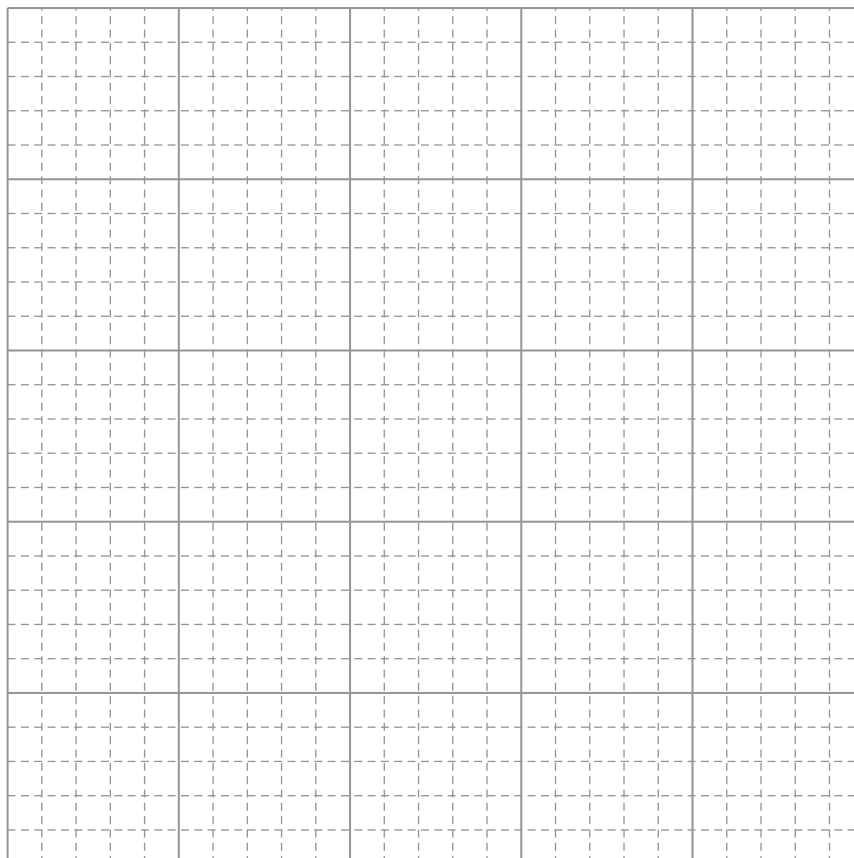

- iii. **Draw** a best-fit line to the data graphed in part (c)(ii).
- (d) Using the best-fit line, **calculate** the internal resistance of the battery.

**FREE-RESPONSE QUESTION: QUALITATIVE/QUANTITATIVE
TRANSLATION**

4. Monochromatic light of wavelength λ_0 is incident on a metal with work function ϕ . Electrons are ejected from the metal and have a maximum speed v_0 .
- (a) When monochromatic light with wavelength greater than λ_0 is incident on the metal, electrons are still ejected. **Indicate** whether the maximum speed of the ejected electrons will be less than, equal to, or greater than v_0 . **Justify** your response.
 - (b) **Derive** an expression for the maximum speed v_0 of the electrons when the original light of wavelength λ_0 is incident on the metal in terms of λ_0 , ϕ , and physical constants, as appropriate.
 - (c) **Indicate** whether the equation derived in part (b) agrees with the justification in part (a). Briefly **justify** your reasoning.

Answer Key and Question Alignment to Course Framework

Multiple-Choice Question	Answer	Skill	Learning Objective	Essential Knowledge
1	A	2.D	9.1.B	9.1.B.1
2	B	3.B	14.5.A	14.5.A.2
3	D	3.C	10.6.A	10.6.A.2
4	A	2.A	15.7.B	15.7.B.2
5	C	3.B	13.4.A	13.4.A.6
6	C	2.C	10.5.B	10.5.B.2
7	B	2.C	11.4.A	11.4.A.1
8	C	3.B	11.8.B	11.8.B.2
9	B	2.B	9.5.A	9.5.A.1
10	C	2.A	12.3.A	12.3.A.1
11	D	2.D	15.4.A	15.4.A.3
12	B	2.A	12.4.A	12.4.A.3
13	A	3.B	14.6.A	14.6.A.6
14	C	2.B	11.8.B	11.8.B.2
15	D	3.C	13.3.A	13.3.A.5

Free-Response Question	Skill	Learning Objective
1	1.C, 2.A, 2.B, 3.B, 3.C	11.4.A, 12.3.B, 12.4.A
2	1.A, 1.C, 2.A, 2.D, 3.B, 3.C	13.3.A, 14.2.A, 14.3.A
3	1.B, 2.B, 2.D, 3.A	11.2.A, 11.3.B, 11.5.B
4	2.A, 2.D, 3.B, 3.C	15.1.A, 15.5.A

**Scoring Guidelines for Question 1: Mathematical Routines****10 points****Learning Objectives:** 11.4.A 12.3.B 12.4.A

- (a) i For indicating that the changing flux will induce an emf in the loop

1 point**Example response:**

$$|\mathcal{E}| = \left| \frac{\Delta\Phi_B}{\Delta t} \right|$$

For correctly substituting an expression for the area of the loop into an expression for the magnetic flux through the loop

1 point**Example response:**

$$\mathcal{E} = \frac{\Delta B}{\Delta t} A = \frac{\Delta B}{\Delta t} \left(\frac{1}{2} \pi r^2 \right)$$

For correctly substituting an expression for the change in the magnetic field into an expression for the magnetic flux through the loop

1 point**Example response:**

$$\begin{aligned} \mathcal{E} &= \frac{(4B_0 - B_0)}{\Delta t} \left(\frac{1}{2} \pi r^2 \right) \\ &= \frac{3B_0 \pi r^2}{2\Delta t} \end{aligned}$$

- (a) ii For substituting the emf from part (a)(i) into a correct expression for power dissipated by the loop

1 point**Example response:**

$$P = \frac{\mathcal{E}^2}{R} = \frac{\left(\frac{3B_0 \pi r^2}{2\Delta t} \right)^2}{R}$$

For multiplying an expression for power by the time Δt to find the total energy dissipated

1 point**Example response:**

$$E = P\Delta t = \frac{9B_0^2 \pi^2 r^4}{4R\Delta t}$$

Example Response:

$$\begin{aligned} |\mathcal{E}| &= \left| \frac{\Delta\Phi_B}{\Delta t} \right| \\ &= \frac{\Delta B}{\Delta t} A \\ &= \frac{(4B_0 - B_0)}{\Delta t} \left(\frac{1}{2} \pi r^2 \right) \\ &= \frac{3B_0 \pi r^2}{2\Delta t} \\ P &= I\Delta V = \frac{(\Delta V)^2}{R} = \frac{\mathcal{E}^2}{R} \\ P &= \frac{\left(\frac{3B_0 \pi r^2}{2\Delta t} \right)^2}{R} = \frac{9B_0^2 \pi^2 r^4}{4R\Delta t^2} \\ E &= P\Delta t = \frac{9B_0^2 \pi^2 r^4}{4R\Delta t} \end{aligned}$$

(a) iii For drawing an arrow to indicate that the current direction is counterclockwise **1 point**

For drawing an arrow to indicate that the magnetic force is in the +x-direction (or to the right) **1 point**

Example Response:

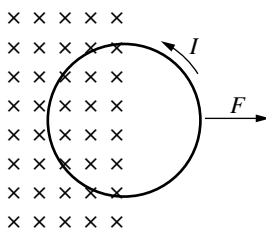

Figure 2

Total for part (a) 7 points

(b) For indicating “yes” for “When it is partially in the region” and “no” for “When it is completely in the region” with an attempt at a justification **1 point**

For indicating that when the loop is partially in the region, the magnetic flux is changing and therefore an emf will be induced **1 point**

For indicating that when the loop is completely in the region, the magnetic flux is constant and no emf is induced **1 point**

Example Response:

An emf will only be induced when the magnetic flux is changing. When the loop is partially in the region, the magnetic field is constant but the area of the region enclosed by the loop is changing, so the flux is changing. When the loop is completely in the region, the flux is not changing.

Total for part (b) 3 points

Total for question 1 10 points

Scoring Guidelines for Question 2: Translation Between Representations

12 points

Learning Objectives: **13.3.A** **14.2.A** **14.3.A**

- | | | |
|-----|--|---------|
| (a) | For showing both rays refracting away from the normal or both rays refracting toward the normal | 1 point |
| | For drawing refracted rays that are refracted away from the normal relative to the incident rays | 1 point |
| | For showing the ray at Point A having a greater angle of refraction than that at Point B | 1 point |

Example Response:

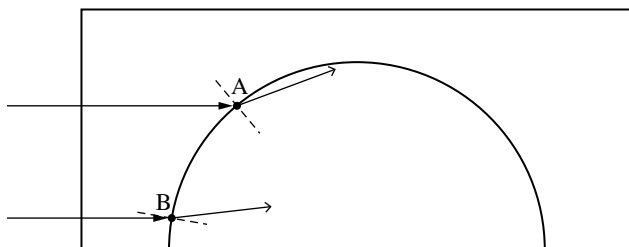

Figure 2

Total for part (a) 3 points

- | | | |
|-----|---|---------|
| (b) | For a derivation that applies the relationship between the speed, wavelength, and frequency of a wave $v = \lambda f$ | 1 point |
| | For indicating that the frequency of the light doesn't change as it passes from glass to air | 1 point |
| | For correctly expressing the wavelength within the glass using the index of refraction of the glass | 1 point |
| | For a correct equation for the change in wavelength in the light. | 1 point |

$$\begin{aligned}\Delta\lambda &= \frac{c}{f_0} - \frac{c}{n_g f_0} \\ &= \frac{c}{f_0} \left(1 - \frac{1}{n_g} \right)\end{aligned}$$

Example Response:

$$v = \lambda f$$

$$n_g = \frac{c}{v}, \quad v = \frac{c}{n_g}$$

$$\frac{c}{n_g} = \lambda f, \quad \frac{c}{n_g f_0} = \lambda_g$$

$$c = \lambda_a f, \quad \frac{c}{f_0} = \lambda_a$$

$$\Delta\lambda = \frac{c}{f_0} - \frac{c}{n_g f_0} = \frac{c}{f_0} \left(1 - \frac{1}{n_g} \right)$$

Total for part (b) 4 points

(c)	For a monotonically increasing line or curve that starts at the origin	1 point
	For a linear function	1 point
	For a line or curve that ends at $\sin\theta_r = 1$ for $h < R$	1 point

Example Response:

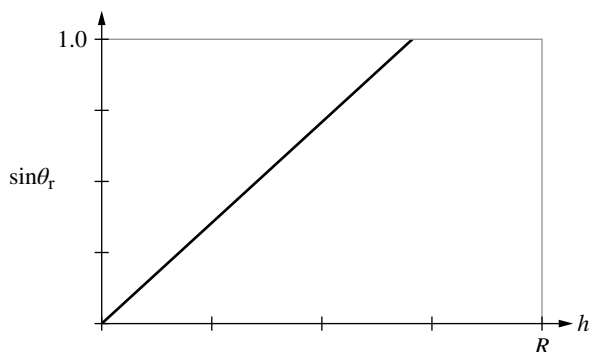

Figure 4

Total for part (c) 3 points

(d)	For correctly identifying whether part (c) is consistent with part (a) with an attempt at a justification using functional dependence reasoning	1 point
	For describing how one feature of the graph in part (c) is consistent with the rays drawn in part (a)	1 point

Example Response:

The graph in part (c) is consistent with the rays in part (a) because the value of h for Point A is larger than for Point B and the refracted angle is greater at Point A. The graph shows that for greater values of h the refracted angle is greater.

Total for part (d) 2 points

Total for question 2 12 points

Scoring Guidelines for Question 3: Experimental Design and Analysis 10 points

Learning Objectives: 11.2.A 11.3.B 11.5.B

- (a) i For drawing a circuit that would allow measurement of the current in and potential difference across R_x **1 point**

Example Response:

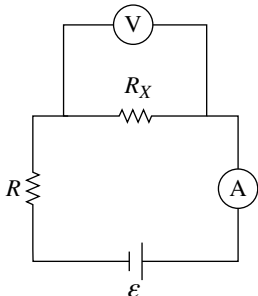

- (a) ii For using multiple resistance values in a description of a procedure consistent with the diagram **1 point**

Example Response:

For each value of R , use the voltmeter to measure the potential difference across R_x , and use the ammeter to measure the current in R_x . Repeat the measurements for multiple values of R .

Total for part (a) 2 points

- (b) For indicating an appropriate relationship between potential difference and current, e.g., current as a function of potential difference **1 point**

For indicating that for an ohmic resistor, the relationship between potential difference and current will be linear **1 point**

Example Response:

Graph current in R_x as a function of potential difference across R_x . The graph will be linear if resistor R_x is ohmic.

Total for part (b) 2 points

- (c) i For indicating quantities that would produce a straight-line graph that could be used to determine the internal resistance of the battery, e.g., resistance and the inverse of current **1 point**

- (c) ii For labeling axes correctly (including units) with a linear scale such that the data fills at least half the area of the graph **1 point**

For plotting the data points correctly **1 point**

- (c) iii For drawing an appropriate line or curve of best fit that approximates the data **1 point**

Example Response:

Graph the resistance R of the resistors as a function of $\frac{1}{I}$.

R (Ω)	I (mA)	$\frac{1}{I}$ (A^{-1})		
10	58	17		
20	44	23		
30	31	32		
40	28	36		
50	22	46		
60	19	53		

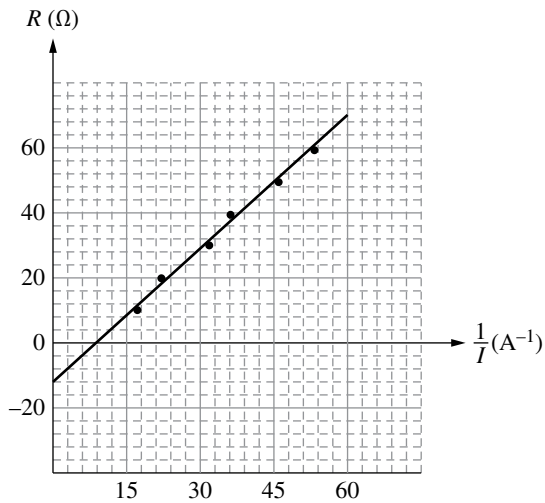

Total for part (c) 4 points

- (d) For using an appropriate feature of the best-fit line to calculate the internal resistance of the battery 1 point
- For calculating the internal resistance within an acceptable range 1 point

Example Response:

$$\mathcal{E} = (r + R)I = rI + RI$$

$$R = \frac{\mathcal{E}}{I} - r$$

The y -intercept is $-r$. Therefore, $r = 12 \Omega$.

Total for part (d) 2 points

Total for question 3 10 points

Scoring Guidelines for Question 4: Qualitative/Quantitative Translation

8 points

Learning Objectives: **15.1.A** **15.5.A**

(a) For indicating that the maximum speed of the electrons will be less than v_0 , with an attempt at a justification **1 point**

For indicating that the energy (or frequency) of the light decreases when the wavelength increases **1 point**

For indicating that the decrease in photon energy (or frequency) leads to a decrease in maximum electron kinetic energy, and therefore a decrease in maximum speed **1 point**

Example Response:

The maximum speed of the electrons will be less than v_0 . A greater wavelength means less photon energy, therefore the maximum speed of the ejected electrons will be less because the maximum kinetic energy will be less.

Total for part (a) **3 points**

(b) For using $K_{\max} = hf - \phi$ with an attempt to substitute for wavelength **1 point**

For a correct substitution of $f = \frac{c}{\lambda}$ **1 point**

For a correct expression for v_{\max} : **1 point**

$$v_{\max} = \sqrt{2 \left(\frac{\frac{hc}{\lambda_0} - \phi}{m_e} \right)}$$

Example Response:

$$K_{\max} = hf - \phi$$

$$\frac{1}{2} m_e v_{\max}^2 = h \left(\frac{c}{\lambda_0} \right) - \phi$$

$$v_{\max} = \sqrt{2 \left(\frac{\frac{hc}{\lambda_0} - \phi}{m_e} \right)}$$

Total for part (b) **3 points**

(c) For a statement that addresses the functional dependence of the maximum speed on the wavelength **1 point**

For a correct justification that links the functional dependence in the equation in part (b) to qualitative reasoning in part (a) **1 point**

Example Response:

In part (b), my derivation shows that as wavelength increases, the value inside the square root decreases, which means v_{max} decreases. This is consistent with the claim in part (a) that light with a greater wavelength results in a smaller maximum speed of the ejected electrons.

Total for part (c) **2 points**

Total for question 4 **8 points**

THIS PAGE IS INTENTIONALLY LEFT BLANK.

AP PHYSICS 2

Appendix



Vocabulary and Definitions of Important Ideas in AP Physics

Vocabulary and Word Choice in AP Physics

The discussions below are included to elaborate on the choice of words and vocabulary in AP Physics.

Many of these words when used in the context of AP Physics have very specific and intentional meanings. The intentional use of certain words within specific contexts can have a significant impact on student understanding as well as their ability to communicate that understanding with others.

The AP Physics Exams will NOT directly assess student understanding of physics vocabulary. For instance, students will not be asked to identify the correct definition of acceleration, or the difference between a system and an object. Students will be expected to use these definitions in contextually appropriate situations. Descriptions and definitions, found in the appendix, are intended to be used as starting points for discussions and are included to help students be more conscientious about the language they use to describe a scenario—that they are inherently thinking more about the underlying principles and ideas that apply to that scenario. This can lead to a deeper and more robust understanding of the course content.

Often in a physics context, words have specific meanings and are used differently than in common colloquial conversation. Common examples of words that have specific physics definitions include object, momentum, work, and heat. The way these words are used within physics is significantly different than the way they may be used elsewhere. Students need to be aware of these subtleties, so that they can communicate appropriately. Ultimately, the language used to describe the natural world is important. Words have meaning, and by considering those meanings when teaching, teachers and students can hone their understanding in measured and intentional increments.

Models

A PHYSICAL, MATHEMATICAL, OR CONCEPTUAL REPRESENTATION OF A SYSTEM OF IDEAS, EVENTS, OR PROCESSES.

A scientific model can be thought of as the set of rules that describe a physical phenomenon. The model sets out the boundaries within which the scientist will consider that phenomenon. Typically, these boundaries simplify a complex scenario to make the analysis and description of that scenario easier and more accessible, particularly to students just beginning their studies in physics.

In introductory physics courses, phenomena are typically analyzed in the most basic conditions, using the most simplified models. This allows students to focus on big concepts and ideas, before exploring more complex models that include more detailed considerations. For example, when modeling the Earth, we typically consider it to be uniform density, spherical, and electrically neutral, even though none of those properties are completely accurate. We typically neglect the difference between the Earth's rotational axis and the axis of the Earth's magnetic field. Most often, only gravitational effects from the Sun are considered. Even tidal effects from the Moon are only considered after introductory courses. This spherical, uniform description of the Earth is a simplified model that is used to focus on bigger concepts without getting bogged down with extraneous details and nuance. The mathematics required to describe these effects tends to get complex quickly. It is important, however, that students understand they are using a simplified model so that later extensions can be added in the context of refining the model—a normal scientific process.

The models chosen to simplify the universe have been done so with alignment to their respective AP Physics courses. The boundaries of these models are

elaborated on within the boundary statements provided the course frameworks, as well as in the conventions for the AP Exams listed on the equation sheets. While nuances of these models are described in detail within each course's curriculum framework, these models can be summarized as:

Unless otherwise stated, students may assume that:

- Frames of reference are inertial.
- Air resistance is negligible.
- Frictional/drag forces are negligible.
- Edge effects of charged plates are negligible.
- Strings, springs, batteries, meters, etc. are ideal.

Representations

A METHOD OF UNDERSTANDING AND COMMUNICATING UNDERSTANDINGS ABOUT PHYSICS.

Once deciding on the boundaries of a model, scientists must decide how to communicate those boundaries to others. A representation is a depiction of a model or aspects of that model. Representations can take many forms, and scientists are consistently developing new representations.

Representations that are frequently used within AP Physics 2, include (but are not limited to):

- Written descriptions
- Drawings and pictures
- Diagrams or schematics
- Mathematical equations or sets of equations
- Graphs and data tables
- Charts
- Energy bar charts
- Free-body diagrams
- Force diagrams
- Ray diagrams
- Vector maps
- Field lines or field line maps
- Equipotential lines

It is important to use and become familiar with as many different representations as possible. What makes a concept or idea clear to one student using one representation may not be clear to another. The more methods which students are given to access and describe content, the more likely they are to use those descriptions. The depth to which a student understands course content is related to the variety of representations with which that student can communicate their knowledge. True understanding

is demonstrated through the ability to use many different representations in many different situations. To this end, the AP Physics 2 Exam will use many representations, as well as require students to create many representations.

Objects

A PHYSICAL THING WHERE THE INTERNAL STRUCTURE AND PROPERTIES OF THE THING ARE IGNORED.

Whether it be a cow, the Earth, a car, or pencil, the object model of these entities has a very specific meaning. Within the context of AP Physics, using the word "object" denotes some key characteristics, and is used, as most models are, to simplify the analysis and descriptions of the interactions between two or more masses. Most notably, an object has no internal structure or surface properties. An object can be considered as a collection of atoms or molecules that stick together in a functional way. A person could imagine handling an object, picking it up, as though the object had no internal structure.

Consider a truck. Most often, it's simply "a truck." The user of the truck does not consider the multitude of components that make a truck a truck: the engine, the doors and windows, the wheels, the frame, the radio, the suspension, and so on. The user treats the truck as a single object, neglecting the constituent parts and structure of the truck itself.

Similar to a well-packed box, an object is treated the same from different perspectives. The truck is a truck as viewed from the top, bottom, or side. However, when carrying a load of unsecured bricks, the object model of the truck may not be sufficient. The motion of the bricks within the truck may affect the behavior of the truck itself. Sudden accelerations—in any direction—may have significant effects on how the truck behaves.

Furthermore, using the object model ignores the physical size of the object itself. Objects cannot be compressed, twisted, or rotated because the physical dimensions of the object are ignored. When considering a truck as object, there would be no need to make the distinction between the front, back, or sides of the truck. However, in the physical world, pushing the top of a truck has a different effect than pushing the bottom or middle of the truck. If the truck is modeled as an object, these effects are ignored, the location of the application of the force is not considered.

A notable discussion of some nuances of the object model can be found when analyzing friction. Friction, by definition, is the interaction of two objects in physical contact with each other. The amount of friction is inherently tied to the structure and properties of

those objects. For instance, two wooden blocks will slide across each other differently if they are covered with sandpaper, or if they are covered in grease. The surfaces of the blocks matter when it comes to describing their interactions. However, the blocks may still be treated as objects because the force of friction exerted on one block by the other block does not depend on the size or shape of the blocks. The amount of area of the blocks that are in contact with each other does not change the force of friction, and so the blocks may still be modeled as objects.

The object model is used throughout AP Physics 2 to simplify the analysis of most phenomena. An “object” can be anything because what the object *is* is not important to the analysis. The properties that matter to the analysis—the mass of the object, the coefficient of friction between the object and a surface, the speed of the object, and so on—can be used to describe any number of physical things. In this case, it is up to the student to create their own mental representation of the situation.

Systems

A COLLECTION OF OBJECTS THAT ARE ANALYZED TOGETHER.

A system is how a physicist chooses to group objects together in order to analyze a given scenario. As students gain a deeper understanding of physics concepts, they will notice that how systems are chosen can significantly simplify (or significantly complicate) the analysis of a problem. There is no single right or wrong way to group objects, but often the preferred method is to choose a system that simplifies the analysis.

Note that in special cases, a system can itself be reduced to a single object. This can happen when the behaviors and interactions of the individual parts of the system do not affect the behavior or analysis of the system as a whole. Consider a box of cereal. In reality, this is a very complex system. A cardboard box, a plastic bag, and a large number of pieces of cereal within. However, the complex motion of the small pieces of cereal within the box are not important to consider when handling the box of cereal. Therefore, the entire box-bag-cereal system can itself be considered as a single object.

Unless the system is chosen to be the entire observable universe (which would require an exceedingly complex analysis), a small group of objects chosen to be a system will exist as part of a larger local environment. The system as a whole then, may interact with that environment. Consider a box of cereal. Perhaps the box is torn, and cereal begins to spill. The physicist has a decision to make with regards to their system: continue

to include every piece of cereal as part of the system (System A), or consider only the cereal inside the box to be part of the system (System B). See the figure below.

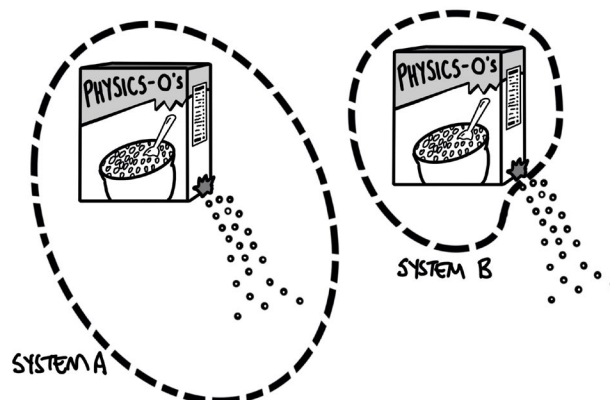

Analyzing System A will be exceedingly complex, as the small pieces of cereal move, bounce, accelerate, collide with each other and the environment, and scatter. Analyzing System B is much simpler: the box is losing mass to the environment, but the box-bag-cereal system may be modeled as a single object that has a changing mass.

Constant or Conserved?

The cereal example is a good place to discuss a subtlety between the terms *constant* and *conserved*, and how the choice of the system determines whether a quantity is constant or conserved. For the leaking cereal box, the total amount of cereal is *conserved*, in both System A and System B. In both choices of systems, the total amount of cereal that exists does not change. However, the choice of system does influence whether the amount of cereal within that system is *constant*. In the first choice, where the student decides to continue to include each individual piece of cereal as part of the system, even as the cereal spills from the box, the total amount of cereal within the system is constant. In the second choice, where the student decides to only consider the cereal within the box as part of the system, the total amount of cereal within the system decreases, and is not constant. However, this cereal is still conserved—the cereal does not simply vanish, disappear, or cease to exist because it is not selected to be part of the system. The cereal is transferred out of the system.

Suppose students wanted to analyze the energy of the box of cereal as it falls toward the Earth. In the box-Earth system, total mechanical energy is both conserved and constant. The total amount of energy within the system does not change as the box gains kinetic energy, and the gravitational potential energy of the box-Earth system decreases. However, in a system consisting only

of the box, the total amount of energy in that system is *not* constant, but energy *is* conserved. The kinetic energy of the box increases, but this increase in energy is due to the transfer of energy into the box system by the external force of gravity doing work on the box. The energy transferred into the box by the force of gravity is not “new” energy that was created by gravity—the total energy of the universe has remained the same and has been conserved.

Particle vs. Point Mass vs. Point Particle vs. Point Charge

In the search to make simplified models of the universe, physicists have developed a wide variety of terms. All of these terms serve the same purpose: to alert others to the simplifications and assumptions made by the model used during the analysis. However, over time, the meanings of these terms drift—or other words that are more favorable replace them. While the course framework for AP Physics 2 outlines the expectations of terms to teachers and students, it is in the interest of students to be aware of additional language used by physicists in a wide variety of settings.

In the most traditional interpretation, a *particle* is an elementary piece of matter that is indivisible and has no internal structure. A particle evokes a mental model of a small piece of matter that interacts with other particles via collisions, like millions of tiny billiard balls on a table. Originally, protons and neutrons and electrons were considered fundamental particles that were indivisible. However, as our understanding of the nature of matter has developed, so has our understanding of these particles. Considering electrons as particles became increasingly problematic as their properties were studied. As physicists continued to explore the nature of the small, it was discovered that protons do have structure and are made up of quarks. These quarks themselves have properties as well. Physicists then started to classify particles as bosons and fermions and hadrons. The more that was learned about these particles, the less appropriate the term *particle* became in order to evoke the mental model of these behaviors and properties. Even so, the term has stuck, and *particle* is still consistently used by many physicists when referring to subatomic pieces of matter, particularly when ignoring the wave nature and quantum properties of that matter.

The modifier *point* preceding mass, *particle*, or *charge* typically indicates to the reader that all other properties are ignored. For instance, a point mass ignores the size, shape, and distribution of that mass, and typically indicates a neutral charge. Students often struggle

with understanding these terms, as they are incredibly abstract representations of the universe. It has been found that students have an easier time learning and applying concepts when using the object model, as objects provide a more concrete foundation upon which students may apply their simplifications. Similar to *particle*, the use of the terms *point mass* and *point charge* (point particle less so) continues in many physics classrooms, and so it is prudent for physics students to be aware of their meaning.

A *point charge* can be introduced as another important simplifying model in physics, like object. A point charge is a charged system that can be modeled as an object because it has a size that is very small compared to the separation of the object or system from other distances in the situation being analyzed. As a result, the internal structure of a point charge can be ignored. Its charge (and potentially mass) will be the only properties of interest.

Charge itself is a word that should be used in specific circumstances. Charge is a property of an object, and not an object itself. The amount and type of charge can be specified. Consider the sentence, “A charge is moving between two horizontal, charged, conducting plates.” What is the charge? Is it an electron? If so, electrons have wave properties, which will probably be ignored. Is the charge on a small sphere? Is the sphere conducting or nonconducting? That matters, because polarization of the sphere between the plates will affect the motion of the sphere. Is the charge a point charge? If so, this implies that the effects of its size and structure are negligible. If this model has not been carefully developed, it may be confusing to have an artificial, abstract point charge that does not exist in nature interact with the very real and plausible concrete scenario of two plates. Within the context of physics, the use of the term *object* simplifies many of these questions. An *object* with charge $+q$, moves between two horizontal, charged conducting plates. The object has mass, and charge, but cannot be polarized because it has no physical size. Referring to an object clearly ignores the wave-particle duality that may confuse the use of an electron. Using *object* has the advantage of clearly denoting which properties are relevant, while also anchoring this mental abstraction to a physical, tangible piece of matter.

Heat vs. Heating vs. Cooling

In physics, the term *heat* has a very specific definition that is a thermodynamic analog to work. Similar to the amount of work done, heat is the amount of energy transferred into or out of a thermodynamic system

through thermal processes (such as conduction, convection, or radiation). This term can be problematic when used in conversation or in print, as the way *heat* is used in a sentence does not emphasize that it is amount of energy being transferred. Similarly, in contexts in which you would discuss *doing work*, the parallel would be *heating* or *cooling*.

Compare this to the way heat is often used in a sentence. To say “the amount of heat transferred” is awkward, if there is a good understanding that heat itself is a transfer of energy. A synonym for that phrase may read “the transfer of thermal energy is transferred” which also may not be the best definition. The same phrase also implies that heat itself is the quantity being transferred, and not simply the transfer of energy. The phrase “the amount of heat done on a system” reads

strangely as well, and is rarely, if ever, used. Students may also incorrectly refer to the “amount of heat an object has.” Using the physics definition of heat, an object cannot *have heat* any more than an object may *have work*. Nonetheless, this incorrect use of the word heat is pervasive in many physics classrooms and so students tend to confuse heat with temperature and incorrectly believe objects and systems can have an amount of heat.

Because the word heat is so commonly misused and is hard to use naturally in a sentence, heating and cooling are used to help emphasize the processes by which thermal energy is transferred. Referring to the transfer of energy through thermal processes like heating or cooling can reinforce the idea of the transfer of energy, without also reinforcing misconceptions of heat and energy.

THIS PAGE IS INTENTIONALLY LEFT BLANK.

AP PHYSICS 2

Table of Information: Equations

ADVANCED PLACEMENT PHYSICS 2 TABLE OF INFORMATION

CONSTANTS AND CONVERSION FACTORS		UNIT SYMBOLS
Avogadro's number,	$N_0 = 6.02 \times 10^{23} \text{ mol}^{-1}$	ampere, A
Universal gas constant,	$R = 8.31 \text{ J}/(\text{mol} \cdot \text{K})$	coulomb, C
Boltzmann's constant,	$k_B = 1.38 \times 10^{-23} \text{ J}/\text{K}$	degree Celsius, °C
1 atmosphere of pressure,	$1 \text{ atm} = 1.0 \times 10^5 \text{ N}/\text{m}^2 = 1.0 \times 10^5 \text{ Pa}$	electron volt, eV
Coulomb constant,	$k = \frac{1}{4\pi\epsilon_0} = 9.0 \times 10^9 \frac{\text{N} \cdot \text{m}^2}{\text{C}^2}$	farad, F
Proton mass,	$m_p = 1.67 \times 10^{-27} \text{ kg}$	hertz, Hz
Neutron mass,	$m_n = 1.67 \times 10^{-27} \text{ kg}$	joule, J
Electron mass,	$m_e = 9.11 \times 10^{-31} \text{ kg}$	kelvin, K
Elementary charge,	$e = 1.60 \times 10^{-19} \text{ C}$	kilogram, kg
Vacuum permittivity,	$\epsilon_0 = 8.85 \times 10^{-12} \text{ C}^2/(\text{N} \cdot \text{m}^2)$	meter, m
Vacuum permeability,	$\mu_0 = 4\pi \times 10^{-7} (\text{T} \cdot \text{m})/\text{A}$	mole, mol
1 electron volt,	$1 \text{ eV} = 1.60 \times 10^{-19} \text{ J}$	newton, N
Planck's constant,	$h = 6.63 \times 10^{-34} \text{ J} \cdot \text{s} = 4.14 \times 10^{-15} \text{ eV} \cdot \text{s}$ $hc = 1.99 \times 10^{-25} \text{ J} \cdot \text{m} = 1240 \text{ eV} \cdot \text{nm}$	ohm, Ω
Speed of light,	$c = 3.00 \times 10^8 \text{ m}/\text{s}$	pascal, Pa
Wien's constant,	$b = 2.90 \times 10^{-3} \text{ m} \cdot \text{K}$	second, s
Stefan-Boltzmann constant,	$\sigma = 5.67 \times 10^{-8} \text{ W}/(\text{m}^2 \cdot \text{K}^4)$	tesla, T
1 unified atomic mass unit,	$1 \text{ u} = 1.66 \times 10^{-27} \text{ kg} = 931 \text{ MeV}/c^2$	volt, V
Universal gravitational constant,	$G = 6.67 \times 10^{-11} \text{ m}^3/(\text{kg} \cdot \text{s}^2) = 6.67 \times 10^{-11} \text{ N} \cdot \text{m}^2/\text{kg}^2$	watt, W
Magnitude of the acceleration due to gravity at Earth's surface,	$g = 9.8 \text{ m}/\text{s}^2$	
Magnitude of the gravitational field strength at the Earth's surface,	$g = 9.8 \text{ N}/\text{kg}$	

PREFIXES		
Factor	Prefix	Symbol
10^{12}	tera	T
10^9	giga	G
10^6	mega	M
10^3	kilo	k
10^{-2}	centi	c
10^{-3}	milli	m
10^{-6}	micro	μ
10^{-9}	nano	n
10^{-12}	pico	p

VALUES OF TRIGONOMETRIC FUNCTIONS FOR COMMON ANGLES							
θ	0°	30°	37°	45°	53°	60°	90°
$\sin \theta$	0	1/2	3/5	$\sqrt{2}/2$	4/5	$\sqrt{3}/2$	1
$\cos \theta$	1	$\sqrt{3}/2$	4/5	$\sqrt{2}/2$	3/5	1/2	0
$\tan \theta$	0	$\sqrt{3}/3$	3/4	1	4/3	$\sqrt{3}$	∞

The following conventions are used in this exam:

- The frame of reference of any problem is assumed to be inertial unless otherwise stated.
- Air resistance is assumed to be negligible unless otherwise stated.
- Springs and strings are assumed to be ideal unless otherwise stated.
- The electric potential is zero at an infinite distance from an isolated point charge.
- The direction of current is the direction in which positive charges would drift.
- All batteries, wires, and meters are assumed to be ideal unless otherwise stated.

ELECTRICITY	MAGNETISM
$ \vec{F}_E = \frac{1}{4\pi\epsilon_0} \frac{ q_1q_2 }{r^2} = k \frac{ q_1q_2 }{r^2}$ $\vec{E} = \frac{\vec{F}_E}{q}$ $ \vec{E} = \frac{1}{4\pi\epsilon_0} \frac{ q }{r^2} = k \frac{ q }{r^2}$ $U_E = \frac{1}{4\pi\epsilon_0} \frac{q_1q_2}{r} = k \frac{q_1q_2}{r}$ $\Delta V = \frac{\Delta U_E}{q}$ $V = \frac{1}{4\pi\epsilon_0} \sum_i \frac{q_i}{r_i}$ $ \vec{E} = \left \frac{\Delta V}{\Delta r} \right $ $C = \frac{Q}{\Delta V}$ $C = \kappa\epsilon_0 \frac{A}{d}$ $E_C = \frac{Q}{\kappa\epsilon_0 A}$ $U_C = \frac{1}{2} Q\Delta V$ $I = \frac{\Delta Q}{\Delta t}$ $R = \frac{\rho\ell}{A}$ $P = I\Delta V$ $I = \frac{\Delta V}{R}$ $R_{\text{eq},s} = \sum_i R_i$ $\frac{1}{R_{\text{eq},p}} = \sum_i \frac{1}{R_i}$ $\frac{1}{C_{\text{eq},s}} = \sum_i \frac{1}{C_i}$ $C_{\text{eq},p} = \sum_i C_i$ $\tau = R_{\text{eq}} C_{\text{eq}}$	$F_B = qvB \sin \theta$ $B = \frac{\mu_0 I}{2\pi r}$ $F_B = I\ell B \sin \theta$ $\Phi_B = \vec{B} \cdot \vec{A}$ $\Phi_B = \vec{B} \cos \theta \vec{A} $ $ \mathcal{E} = \left \frac{\Delta \Phi_B}{\Delta t} \right $ $\mathcal{E} = B\ell v$ <p> <i>A</i> = area <i>B</i> = magnetic field <i>F</i> = force <i>I</i> = current ℓ = length <i>q</i> = charge <i>r</i> = distance, radius, or position <i>t</i> = time <i>v</i> = velocity or speed \mathcal{E} = emf θ = angle Φ = flux </p>
THERMAL PHYSICS	
	$P = \frac{F_{\perp}}{A}$ $K_{\text{avg}} = \frac{3}{2} k_b T = \frac{1}{2} m v_{\text{rms}}^2$ $\frac{Q}{\Delta t} = \frac{kA\Delta T}{L}$ $PV = nRT = Nk_B T$ $U = \frac{3}{2} nRT = \frac{3}{2} Nk_B T$ $W = -P\Delta V$ $\Delta U = Q + W$ $Q = mc\Delta T$ <p> <i>A</i> = area <i>c</i> = specific heat <i>F</i> = force <i>k</i> = thermal conductivity <i>K</i> = kinetic energy <i>L</i> = length <i>m</i> = mass <i>n</i> = number of moles <i>N</i> = number of atoms <i>P</i> = pressure <i>Q</i> = energy transferred to a system by heating <i>t</i> = time <i>T</i> = temperature <i>U</i> = internal energy <i>v</i> = velocity or speed <i>V</i> = volume <i>W</i> = work done on a system </p>

WAVES, SOUND, AND OPTICS		MODERN PHYSICS	
$\lambda = \frac{v}{f}$	$a = \text{width}$	$E = hf$	$A = \text{area}$
$n = \frac{c}{v}$	$A = \text{amplitude}$	$\lambda = \frac{h}{p}$	$b = \text{constant}$
$n_1 \sin \theta_1 = n_2 \sin \theta_2$	$d = \text{separation}$	$\lambda = \frac{c}{f}$	$E = \text{energy}$
$\frac{1}{s_i} + \frac{1}{s_o} = \frac{1}{f}$	$D = \text{path length}$	$\lambda_{\text{max}} = \frac{b}{T}$	$f = \text{frequency}$
$ M = \left \frac{h_i}{h_o} \right = \left \frac{s_i}{s_o} \right $	$f = \text{frequency or focal length}$	$P = A\sigma T^4$	$K = \text{kinetic energy}$
$\Delta D = m\lambda$	$F = \text{force}$	$K_{\text{max}} = hf - \phi$	$m = \text{mass}$
$\Delta D = a \sin \theta$	$h = \text{height}$	$\Delta \lambda = \frac{h}{m_e c} (1 - \cos \theta)$	$N = \text{number of particles}$
$a \left(\frac{y_{\text{min}}}{L} \right) \approx m\lambda$	$\ell = \text{length}$	$E = mc^2$	$p = \text{momentum}$
$\Delta D = d \sin \theta$	$L = \text{distance}$	$N = N_0 e^{-\lambda t}$	$P = \text{power}$
$d \left(\frac{y_{\text{max}}}{L} \right) \approx m\lambda$	$m = \text{order or mass}$	$\lambda = \frac{\ln 2}{t_{1/2}}$	$t = \text{time}$
$v_{\text{string}} = \sqrt{\frac{F_T}{m/\ell}}$	$M = \text{magnification}$		$T = \text{absolute temperature}$
$T = \frac{1}{f}$	$n = \text{index of refraction}$		$\theta = \text{angle}$
$x(t) = A \cos(\omega t) = A \cos(2\pi ft)$	$s = \text{position}$		$\lambda = \text{wavelength or decay constant}$
$y(x) = A \cos\left(2\pi \frac{x}{\lambda}\right)$	$t = \text{time}$		$\sigma = \text{constant}$
$ f_{\text{beat}} = f_1 - f_2 $	$T = \text{period}$		$\phi = \text{work function}$
	$v = \text{speed}$		
	$x = \text{position}$		
	$y = \text{position}$		
	$\lambda = \text{wavelength}$		
	$\theta = \text{angle}$		
	$\omega = \text{angular frequency}$		

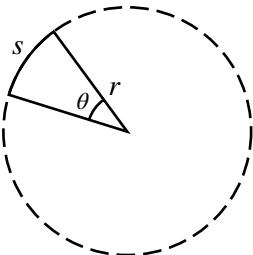
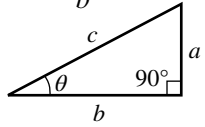
GEOMETRY AND TRIGONOMETRY			
Rectangle $A = bh$	Rectangular Solid $V = \ell wh$		Right Triangle $a^2 + b^2 = c^2$
Triangle $A = \frac{1}{2}bh$	Cylinder $V = \pi r^2 \ell$ $S = 2\pi r \ell + 2\pi r^2$		$\sin \theta = \frac{a}{c}$
Circle $A = \pi r^2$ $C = 2\pi r$ $s = r\theta$	Sphere $V = \frac{4}{3}\pi r^3$ $S = 4\pi r^2$		$\cos \theta = \frac{b}{c}$
			$\tan \theta = \frac{a}{b}$
			

MECHANICS AND FLUIDS

$$v_x = v_{x0} + a_x t$$

$$x = x_0 + v_{x0} t + \frac{1}{2} a_x t^2$$

$$v_x^2 = v_{x0}^2 + 2a_x(x - x_0)$$

$$\vec{x}_{\text{cm}} = \frac{\sum m_i \vec{x}_i}{\sum m_i}$$

$$\vec{a}_{\text{sys}} = \frac{\sum \vec{F}}{m_{\text{sys}}} = \frac{\vec{F}_{\text{net}}}{m_{\text{sys}}}$$

$$|\vec{F}_g| = G \frac{m_1 m_2}{r^2}$$

$$|\vec{F}_f| \leq |\mu \vec{F}_n|$$

$$\vec{F}_s = -k\Delta\vec{x}$$

$$a_c = \frac{v^2}{r}$$

$$K = \frac{1}{2} m v^2$$

$$W = F_{\parallel} d = F d \cos \theta$$

$$\Delta K = \sum W_i = \sum F_{\parallel, i} d_i$$

$$\Delta U_s = \frac{1}{2} k (\Delta x)^2$$

$$U_G = -\frac{G m_1 m_2}{r}$$

$$\Delta U_g = mg \Delta y$$

$$P_{\text{avg}} = \frac{W}{\Delta t} = \frac{\Delta E}{\Delta t}$$

$$P_{\text{inst}} = F_{\parallel} v = F v \cos \theta$$

$$\vec{p} = m\vec{v}$$

$$\vec{F}_{\text{net}} = \frac{\Delta \vec{p}}{\Delta t} = m \frac{\Delta \vec{v}}{\Delta t} = m\vec{a}$$

$$\vec{J} = \vec{F}_{\text{avg}} \Delta t = \Delta \vec{p}$$

$$\vec{v}_{\text{cm}} = \frac{\sum \vec{p}_i}{\sum m_i} = \frac{\sum (m_i \vec{v}_i)}{\sum m_i}$$

a = acceleration

d = distance

E = energy

F = force

J = impulse

k = spring constant

K = kinetic energy

m = mass

p = momentum

P = power

r = radius, distance, or position

t = time

U = potential energy

v = velocity or speed

W = work

x = position

y = height

θ = angle

μ = coefficient of friction

$$\omega = \omega_0 + \alpha t$$

$$\theta = \theta_0 + \omega_0 t + \frac{1}{2} \alpha t^2$$

$$\omega^2 = \omega_0^2 + 2\alpha(\theta - \theta_0)$$

$$v = r\omega$$

$$a_r = r\alpha$$

$$\tau = r_{\perp} F = r F \sin \theta$$

$$I = \sum m_i r_i^2$$

$$I' = I_{\text{cm}} + M d^2$$

$$\alpha_{\text{sys}} = \frac{\sum \tau}{I_{\text{sys}}} = \frac{\tau_{\text{net}}}{I_{\text{sys}}}$$

$$K = \frac{1}{2} I \omega^2$$

$$W = \tau \Delta \theta$$

$$L = I \omega$$

$$L = r m v \sin \theta$$

$$\Delta L = \tau \Delta t$$

$$\Delta x_{\text{cm}} = r \Delta \theta$$

$$T = \frac{1}{f}$$

$$T_s = 2\pi \sqrt{\frac{m}{k}}$$

$$T_p = 2\pi \sqrt{\frac{\ell}{g}}$$

$$x = A \cos(2\pi f t)$$

$$x = A \sin(2\pi f t)$$

$$\rho = \frac{m}{V}$$

$$P = \frac{F_{\perp}}{A}$$

$$P = P_0 + \rho g h$$

$$P_{\text{gauge}} = \rho g h$$

$$F_b = \rho V g$$

$$A_1 v_1 = A_2 v_2$$

$$P_1 + \rho g y_1 + \frac{1}{2} \rho v_1^2 = P_2 + \rho g y_2 + \frac{1}{2} \rho v_2^2$$

a = acceleration

A = amplitude or area

d = distance

f = frequency

F = force

h = height

I = rotational inertia

k = spring constant

K = kinetic energy

ℓ = length

L = angular momentum

m = mass

M = mass

P = pressure

r = radius, distance, or position

t = time

T = period

v = velocity or speed

V = volume

W = work

x = position

y = vertical position

α = angular acceleration

θ = angle

ρ = density

τ = torque

ω = angular speed

THIS PAGE IS INTENTIONALLY LEFT BLANK.

