

ZTE

Vol. 9 No. 3

3 / 2007

TECHNOLOGIES

IMS Special Issue

**ZIMS: Paving the Way to the Future
of Communications in Western Europe** P4

**ZTE's Core Network Migration
Strategies Towards IMS** P10

IMS: A Catalyst for Convergence P14

ZIMS—Open, Tried, and True! P17



Letter of Invitation

Dear Madam or Sir:

IMS-IP Multimedia Subsystem—which has been one of the hottest topics of the industry for a couple of years, is a promising technology for telecom operators to achieve convergence. ZTE is sponsoring the next IMS World Forum hosted by Informa, and is glad to invite you to join this event in Monte Carlo from April 24th to 26th for sharing values and experiences with us.

ZTE has developed an end-to-end IMS solution (ZIMS), which is a Fixed-Mobile Convergence solution that complies with 3GPP, 3GPP2 and TISPA standards. As a key player in the global telecom market, the company has been chosen exclusively as the provider of an end-to-end IMS solution by a Chinese leading mobile operator; and is working on the first IMS trial in the world covering WCDMA, CDMA2000 and fixed networks with another Chinese carrier.

At this IMS World Forum, ZTE will manage a key session “From theory to Practice: a fully interoperable global IMS framework” on Day One (April 24th) and a panel discussion on “How to manage end to end QoS in an IMS network” on Day Three (April 26th). As an exhibitor, we would also like to invite you to visit our booth.

With strong customized ability and cost-effective product portfolio, ZTE will always be your reliable partner. We are looking forward to meeting you at the IMS World Forum in April.

Best regards,
ZTE Corporation

ZTE TECHNOLOGIES

A Monthly Publication

Vol. 9 No. 3 Issue 86 March/2007



Tech Feature

ZTE's Core Network Migration Strategies Towards IMS

IMS, being widely accepted by the industry as the NGN core network architecture, can help operators construct a unified platform of network and service convergence.

Corporate News

- 1 ZTE Tops 2006 International CDMA Market
- 2 ZTE Wins Softswitch Deal
- 2 ZTE to Provide High-end Router Switch Products to Bolivia's COTAS
- 2 ZTE Awarded Chinese TD-SCDMA network Entry Certificate

Industrial News

- 3 Telco's IPTV Users More Than Double
- 3 Swisscom Bids \$4.9b for Fastweb
- 3 3 Launches Ad-Based Services
- 3 AT&T Expands Footprint

Operation

4 ZIMS: Paving the Way to the Future of Communications in Western Europe

There is a huge gap between the ideal picture of IMS-based FMC and European operators' current networks comprising a mix of different generations of platforms.

Leading Edge



ZTE's IMS-Based Voice Call Continuity Solution

ZTE has developed a competitive IMS-based VCC solution from its broad experience in GSM/UMTS/CDMA1X/IMS core network, service, and terminal.

Tech Feature



IMS: A Catalyst for Convergence

The dream of one phone, one number, one address book, and one voicemail is ready to come true with the advent of IMS technology.

Tech Feature

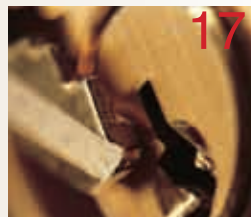

ZIMS—Open, Tried, and True!

As IMS promises an open architecture, equipment from different vendors has to be compatible and be able to interwork with each other.

CONTENTS

ZTE TECHNOLOGIES

Tech Feature

SDMP: A Common Platform for IMS 20

The Service Delivery & Management Platform (SDMP) enables the sharing of network resource and service applications, faster time-to-market, and abundant multimedia services.

Tech Feature

ZIMS—Advancing Dynamic QoS 23

The dynamic QoS sells networking resources to the highest bidder in the Diffserv network. Only the customers, paying premium prices, will enjoy guaranteed services.



Press Clipping

Vodafone Deal Hits Makers of Handsets 26

Handsets

ZTE Gears up for Mobile TV Growth 27

Editorial Board

Editor-in-Chief: Gu Yongcheng

Vice Editor-in-Chief: Huang Xinming

Editorial Director: Zhao Lili

Executive Editor: Liu Yang

Circulation Manager: Chen Jiali

Subscription / Customer Services

Subscription to *ZTE TECHNOLOGIES*

is free of charge

Tel: +86-755-26775203

Fax: +86-755-26775217

Email: chen.jiali@zte.com.cn

Website: www.zte.com.cn/magazine/English

Editorial Office

Marketing System

11F, R&D Building, ZTE Plaza,

Hi-tech Road South, Hi-tech Industrial Park,

Shenzhen, P.R.China

Postcode: 518057

Tel: +86-755-26775215

Fax: +86-755-26775217

Email: liu.yang2@zte.com.cn

ZTE Profile

ZTE is a leading global provider of telecommunications equipment and network solutions. ZTE's product range is the most complete in the world—covering virtually every sector of the wireline, wireless and handset markets. The company delivers products and services to customers in more than 100 countries.



**Main Topic of Next Issue:
Value-added services**

ZTE Tops 2006 International CDMA Market

ZTE Corporation, a leading global provider of telecommunications equipment and network solutions, topped the world CDMA equipment market in 2006 by number of shipments.

ZTE shipped over 12,000 units of CDMA BTS equipment from January to December 2006, 41 percent of the global market by number of contracts according to China's Ministry of Information Industry (MII) telecom academy.

Industry analyst Ovum anticipates that ZTE will achieve 20 percent market share in China's coming 3G CDMA 2000 market and will gain a rapid market share increase as a result.

"Our market achievements are strongly supported by our advanced products and focused R&D. We were the first in the world to deploy an IOS V5.0 based all-IP commercial CDMA 2000 network, six months earlier than our competitors. We were also the first to construct a commercial EV-DO Rev.A network," said Xie Daxiong, SVP of ZTE. "We have constructed over 50 EV-DO networks in over 40 countries and regions and we are

confident we will achieve even more in both the CDMA 2000 1X and EV-DO markets."

To date, ZTE has deployed over 60 million lines of CDMA equipment in over 100 carriers' networks in more than 60 countries and regions, including India, Indonesia, the Czech Republic and a variety of countries in Africa, as well as in developed markets like the U.S.A. and Europe.

In India, ZTE was the sole CDMA equipment provider to the country's three largest CDMA operators Reliance, Tata and BSNL in 2006. ZTE equipment currently accounts for 85 percent of BSNL's CDMA market. ZTE has also undertaken Tata's national rural telecoms project and has helped Reliance expand its CDMA network at the speed of one million new users per month.

In Indonesia, ZTE has worked with Indosat to expand a 3G Softswitch core network in 12 cities across the country and has been awarded a large-capacity CDMA contract by PT Telkom Indonesia.

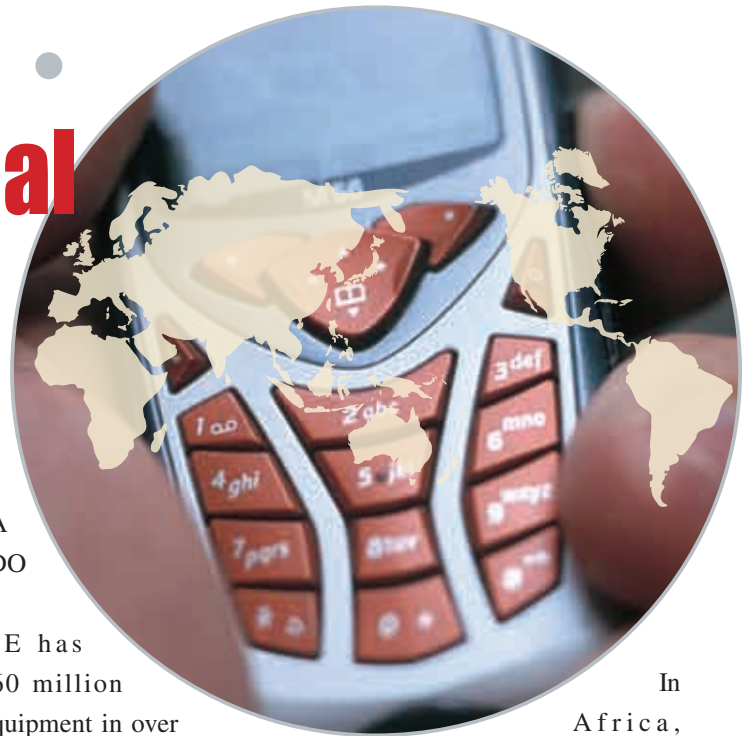

In Africa, ZTE's CDMA products are in use in over 70% of African countries and have helped with local telecom projects from the first national CDMA cellular network in Morocco in North Africa to the national rural network in Nigeria in West Africa.

Across Europe, ZTE constructed Europe's first EV-DO Rev A. national network in the Czech Republic; the EV-DO network constructed by ZTE has been put into commercial use in Norway and ZTE has established a strategic partnership with OTE to deploy the first 450 MHz 3G CDMA 2000 network in Estonia.

In the U.S., ZTE has won a 3G CDMA 2000 network with regional operators Copper Valley Group and ClearTalk and ZTE's equipment is currently under test with several tier one carriers' labs. (ZTE Corporation)

ZTE Wins Softswitch Deal

ZTE Corporation, a leading global provider of telecommunications equipment and network solutions, has delivered its first telecoms infrastructure equipment in the UK to Global e Networks, a new player on the European telecoms scene.

The ZTE Class 5 Softswitch system is being installed in London's Docklands telecoms hub, enabling Global e Networks to offer wholesale IP-based communications capabilities to the UK and European markets.

ZTE's Class 5 Softswitch allows telecommunications companies to implement the latest IP-enabled call controls and services on a distributed telephony basis, without any significant migration costs.

Robert Rees, director of Global e Networks, said that, thanks to ZTE's Softswitch technology, his company

will offer a high quality portfolio of telecoms facilities to a wide range of third-party quality resellers.

"These facilities will embrace a variety of services that include voice, SMS, content, IP Centrex, advertising and audio-visual conferencing, all of which will be handled by ZTE's soft-switch technology," Rees explained. "The unique aspect of the Global e service—as well as offering an integrated portfolio of communications facilities such as full billing services to third-party resellers—is its advertising, sponsorship and branding potential."

Fang Rong, ZTE's vice president of European strategy, said that the Global e deal is the company's first major Softswitch sale in Western Europe and comes as a result of many months of hard work by ZTE's technical sales and engineering staff alongside their counterparts at Global e Networks.



ZTE Awarded Chinese TD-SCDMA network Entry Certificate

ZTE Corporation, a leading global provider of telecommunications equipment and network solutions, has been named as one of the first vendors to be awarded China's TD-SCDMA network entry certificate, as issued by the country's Ministry of Information Industry (MII).

The TD-SCDMA equipment covered by the certificate falls into four categories: core network equipment, radio network controller equipment, base station equipment and application platform equipment.

Before obtaining the network entry certificate, companies must undergo a series of stringent tests organized by the MII. The ZTE TD-SCDMA equipment was tested in China's trial TD-SCDMA stations in Xiamen, Shanghai and Qingdao, and achieved excellent results.

(ZTE Corporation)

ZTE to Provide High-end Router Switch Products to Bolivia's COTAS

ZTE Corporation, a leading global provider of telecommunications equipment and network solutions, has signed an agreement with Bolivia's COTAS (Cooperativa de Telecomunicaciones Santa Cruz Ltda) to enable the expansion of the operator's ADSL network.

Products will include the ZXR10G high-end routing switch and the ZXR10

3900 series of routing switches.

Products from the awarding-winning ZXR10 series will be deployed at the network's convergence layer to increase the carrier network's bandwidth and reliability, thus enabling COTAS to increase revenue and customer retention through being able to offer improved services and applications to its customers.

Telco's IPTV Users More Than Double

Shanghai Telecom's IPTV (Internet Protocol) subscriber base has reached 128,000, surpassing Harbin to become the No. 1 city in user number in the Chinese mainland, the local carrier said on March 8th. IPTV provides people interactive TV services such as

video on demand (VoD) and subscribed sports channels, and allows users to watch the programs at any time they want.

The Web-based TV service generates a high profit margin for telecom operators compared with traditional voice and broadband business, industry

insiders said. Shanghai Telecom has more than doubled its IPTV user base in the past two months from the 60,000 at the end of last year.

China Netcom operates an IPTV service in Harbin, capital of Heilongjiang Province in the northeast, with about 70,000 subscribers.

Swisscom Bids \$4.9b for Fastweb

Swisscom, the former state telecommunications monopoly, said it offered to buy Fastweb, Italy's second-largest fixed-line phone company, for 3.7 billion euros (US\$4.9 billion) to expand into the Mediterranean nation.

The offer values Fastweb at 47 euros (US\$61.70) a share, Swisscom said in a statement on March 12th.

"Italy is one of the most attractive broadband markets in Europe with significant expected growth potential over the next few years," Swisscom said in a statement.

Fastweb, which has 1.1 million customers, was the first company in Italy to offer a so-called triple-play package combining voice, data and video over the Internet.



AT&T Expands Footprint

AT&T Inc. announced a major expansion of its global Wireless Fidelity (Wi-Fi) footprint for business customers, adding 13,000 hot spots around the world where mobile workers can link to their corporate networks. The new hot spots, available to AT&T Remote Access customers, include the popular

airports, hotels and restaurants.

Total global Wi-Fi service area offered by AT&T now exceeds more than 48,000 hot spots in 79 countries. This includes service to nearly 15,000 hot spots available to AT&T Remote Access customers in the U.S. in locations such as airports, coffee houses, and restaurants.

3 Launches Ad-Based Services

3, the mobile media company, has announced the launch of a new range of free-to-access content for customers on its Planet 3 portal. Working in partnership with Rhythm New Media, the new service will be supported by personalized advertising from major brands, meaning content that was previously paid for can now be viewed for free by customers.

The new ad-supported service will be available to 3's customers from April and represents the realization of a new business model for the mobile content business. With the launch of ad-funded content 3 has significantly increased the range of video content available to customers for free. Video content been made available on the portal free includes a selection of news, comedy, celebrity gossip, animations and film.

ZIMS: Paving the Way to the Future of Communications in Western Europe

Frank Toupin, Director of Product Marketing for Western Europe

Nobody has the truth when talking about the future, but it is of paramount importance to clearly understand the current trends and to avoid a “wait and see” attitude as the world is changing very fast and is opening the door to new service providers. Indeed, we are entering a new era for the telecommunications industry in Western Europe. The ubiquitous broadband and IP are radically changing the traditional models of operators. Major Internet players, like Google, Yahoo, and eBay are eager to compete directly with telecom operators. If any evidence is needed, we only have to consider the billions of US dollars put on the table by eBay to acquire Skype. As far as wireless is concerned, the incredible increase in mobile penetration over the last decade is dramatically slowing down and it is wise not to bet too much on the increase of mobile Average Revenue Per User (ARPU).

For some of the Western European operators, new streams of revenues come from emerging markets. For example, Telefónica is one of the integrated operators with the largest percentage of its business outside its domestic market in Spain. Telefónica has been present in Latin America for over 15 years, with cumulative investments of more than Euro 70 billions; in Europe, Telefónica O2 has operations in the UK, Ireland, Germany and the Czech Republic. Besides, Vodafone and Telenor have realized the huge potential of emerging markets with the acquisitions in Eastern Europe and the Asia-Pacific region.

The convergence trend

Now, when dealing with the domestic market which is very saturated, the carriers have to solve the following questions: What the new business models for delivering telecoms services should be? How to get more values and revenues from their networks? How to increase customer loyalty? How to drastically cut down the recurring costs of their networks which are supposed to always provide more bandwidth and services?

The fact is that broadband and especially the wireless broadband enabled by HSDPA/HSUPA makes it possible to realize the idea of “seamless access”. This is convergence. Basically, convergence stands for the unavoidable evolution from separate telecoms networks towards a unified network offering personalized and converged services through a universal “media portal”. This network evolution is inevitable, since “All IP” is radically changing the business models for operators. Indeed more intelligence is pushed to the edge of the network and the wide use of Voice over IP is cannibalizing the telephony revenues.

Convergence stands for the unavoidable evolution from separate telecoms networks towards a unified network offering personalized and converged services through a universal “media portal”

Consequently, operators have to significantly reduce their operational costs, to retain their customers, and to look for new revenue generating opportunities. Of course, those drivers may have different priorities, depending on the operators.

Each operator has a different need for IP Multimedia Subsystem (IMS). Fixed operators need to quickly change their current business models from providing access to providing services. For these operators, IMS will bring more intelligence in the network enabling more control on enhanced services by blending voice, data, and video. For mobile operators, IMS becomes particularly advantageous when a number of new services, especially blended services, are introduced.

The best candidates to implement IMS are the integrated operators who have both fixed and mobile networks since the standard architecture for FMC is based on IMS. For these operators, the equation is simple: cost reductions and new revenue streams. The services convergence will increase service usage as it enables seamless service access (SMS, MMS, and video); and the networks convergence will reduce Operational Expenditure (OPEX). From an end-user’s perspective, IMS will be the engine enabling a “new experience in telecommunication” as envisioned by France Telecom.

As you know, British Telecom’s 21st Century Network is one of the biggest projects in the world designed around convergence. So far, £10 billion pounds have been spent on it

and the operator aims to switch the entire PSTN network to IP by 2010. Indeed, there exists an additive cost of maintaining the legacy services while moving to the new NGN, which mandates a quick switch-off of the legacy platforms. British Telecom has planned annual savings of £1 billion per annum when the transition to the new network is complete.

Like British Telecom, the Dutch operator KPN intends to switch off the traditional PSTN Network by 2010. KPN, who provides telephone, Internet and television services to personal customers through its fixed network in the Netherlands, explained that moving to an all-IP network will allow it to significantly reduce its workforce in fixed-networks division. Once its five-year headcount reduction program is completed, only “a few thousand”

will work in fixed networks. Basically, if voice is going to be almost free, then it must cost virtually nothing to provide. In other words, voice should be an application that happens to use the same common infrastructure as the other communication applications.

On the other hand, France Telecom has a complete different approach with IMS. France Telecom will keep half of its TDM Network for a long time. With the NeXT project, France Telecom—using Orange as the global brand—wants to offer to their end customers a “new experience in telecommunication”, and to develop new seamless access services. The NeXT is a complete transformation programme which will position France Telecom as the leading integrated service provider in Europe. It is focused on:

- Shifting from network access to

services

- Building a new revenue model focused on converged services

In its most advanced form, Fixed-Mobile Convergence (FMC) allows the delivery of services regardless of the access medium or terminal. France Telecom and Deutsche Telecom are pursuing this path, attempting to offer subscribers the same services, a single phone number and a single voicemail—regardless of whether they are using a mobile and fixed connection. To sum up, FMC brings:

- Service ubiquity across multiple access networks: Personalized services can be created with a single user profile, improving customer satisfaction and reducing churn
- Full service interaction between fixed and mobile networks: Seamless access to SMS, MMS, video telephony, and etc., which can boost services usage
- An alternative solution to Peer-to-Peer VoIP like Skype: Dual mode mobile handsets to extend the VoIP usage beyond home, providing revenue protection

It is interesting to note that in France, Spain and Poland, France Telecom is offering all services which make these countries a good target for the Fixed-Mobile Convergence.

In the same way, the Norwegian operator Telenor reckons shift towards IMS-based platforms over the next few years. It holds 3G licenses in Norway, Sweden, Denmark and Hungary and is one of Scandinavia’s leading fixed broadband providers with a total of 1.2 million subscriptions. It will offer pure



mobile operation, broadband fixed operation, or a combination of both depending on the countries. The IMS services will partly be implemented in standalone SIP application servers (like Instant Messaging or Presence servers) according to the Open Services Architecture (OSA) principles.

What about mobile centric operators? They are driving fixed to mobile substitution by extending indoor coverage, and also moving towards FMC offering by partnering with fixed carriers. For example, Vodafone launched a program last year called “Mobile Plus” in three initial areas. The program is expected to generate 10% of Vodafone’s total revenues in the next three years:

- Extend reach with Vodafone At Home and Vodafone At Office
- Integrate mobile with Internet/PC
- Deliver advertising based services

Recent Vodafone announcements on FMC and ADSL access included partnerships with Arcor in Germany, Fastweb in Italy, and BT in UK. In Germany, Vodafone introduced a new flat rate package under the slogan of “Flat to the Power of Three” that started on the 1st of September 2006. It comprises a mobile, fixed network and DSL Internet flat rate. After that, Vodafone also announced a heads of agreement with BT Wholesale to offer broadband services in the UK and a commercial agreement with leading Italian broadband player Fastweb.

ZTE's IMS solution—ZIMS

Despite the hype around IMS during the previous years, the

industry is now looking to its future and developing the next set of services that the increasingly discerning consumers will expect. ZTE, the fastest growing global provider of telecommunications equipment and network solutions has built a complete IMS solution—ZIMS—focusing on Fixed-Mobile Convergence using 3GPP Release 6 and TISPAN NGN Release 1 as a baseline for IMS implementation and convergence. Its third commercial release incorporates 3GPP Release 7, including key features like VCC for Voice Call Continuity.

ZTE has already started testing activities with leading pan European operators. In China, ZTE was selected as the exclusive provider for IMS by one of China’s leading operators. ZTE has also already achieved three commercial trials in China starting earlier in 2006.

It’s vital that the migration of existing services to IMS and NGN should be seamless. Despite the clear and substantial business and technology benefits, the migration towards IMS is very challenging for European operators. Indeed, there is a huge gap between the ideal picture of IMS-based FMC and European operators’ current networks comprising a mix of different generations of platforms. As there is not a “one-size-fits-all” solution for FMC, the ZIMS provides flexible

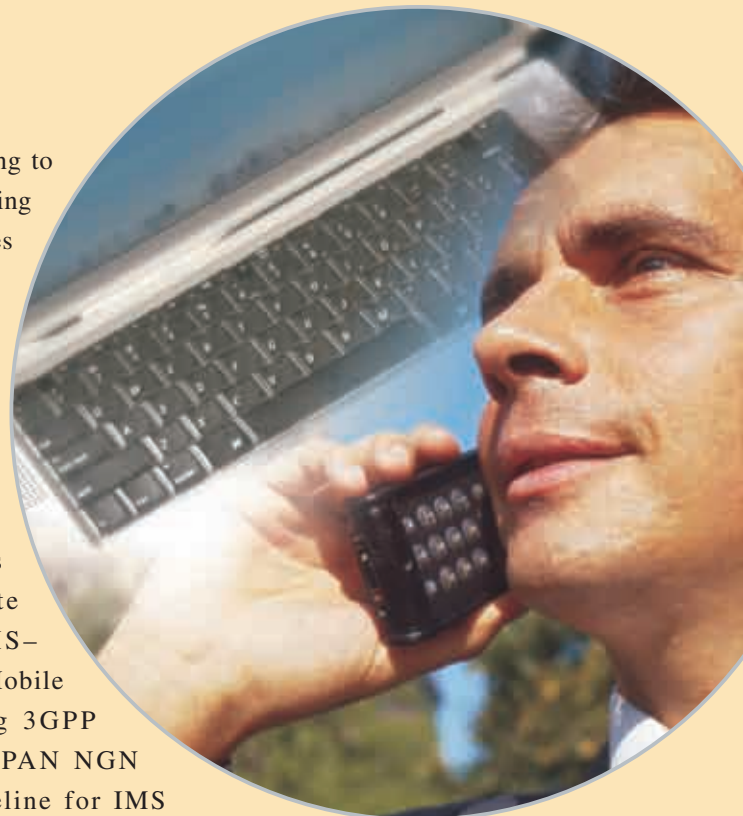

product mapping and high scalability. The ZTE V3 platform supports most of the IMS/TISPAN components like CSCF Server, AGCF, HSS, MRFC/MRFP, Media Gateway, and etc., which leads to a high degree of flexibility as it can mix different IMS/TISPAN functions within one cabinet.

In addition, internationalization being at the heart of ZTE’s growing strategy, ZTE has already established partnerships with over 500 operators in more than 100 countries around the world. In order to reinforce its presence in Europe, ZTE and France Telecom announced in December 2005, a long term R&D partnership and ZTE decided to launch a R&D, Training and Maintenance Center in Poitiers, France—which will have more than 200 employees located at the Futuroscope of Poitiers. Indeed, ZTE is devoted to helping operators better meet the needs of their customers.

ZTE TECHNOLOGIES



ZTE's IMS-Based Voice Call Continuity Solution

Zhang Zhilong

Overview

Voice Call Continuity (VCC) is being developed in 3GPP to enable a two-way voice call handover between GSM/UMTS circuit-switched (CS) domain and IMS domain. The VCC application provides fixed mobile converged voice services which enable customers to make voice calls over mobile networks and WLAN access points using cellular/Wi-Fi dual-mode handsets; when the user equipment requests a handover (based on selected choices of users), the VCC application will perform domain transfer for an active voice call.

The 3GPP defined VCC is not the only way to perform voice call continuity. Unlicensed mobile access (UMA) technology was developed earlier than VCC. Several large carriers are using UMA as a short or mid-term solution for converged services; however, operators are expected to eventually move to VCC to support convergence.

IP Multimedia Subsystem (IMS) is seen as the ultimate architecture enabling multimedia Fixed-Mobile Convergence (FMC); the IMS-based voice call continuity is also seen as a

long term solution. Because of that, its implementation has been one of the hottest topics in the industry. Unlike the current UMA solution, VCC is fully IMS-compliant.

ZTE's IMS-based VCC solution

When 3GPP began to work on VCC standard initiative early 2005, ZTE has already devoted the manpower to closely study VCC issues. ZTE, with consolidated product lines and a pool of experts, has developed a competitive IMS-based VCC solution from its

broad experience in GSM/UMTS/CDMA1X/IMS core network, service, and terminal.

Fig. 1 shows ZTE's IMS-based VCC solution. It encompasses several key parts: IMS infrastructure, CS domain, and VCC application server. The ZTE VCC solution is essentially an IMS architecture that incorporates the VCC features.

IMS infrastructure

This is an important part of the ZTE VCC solution. Compliant to

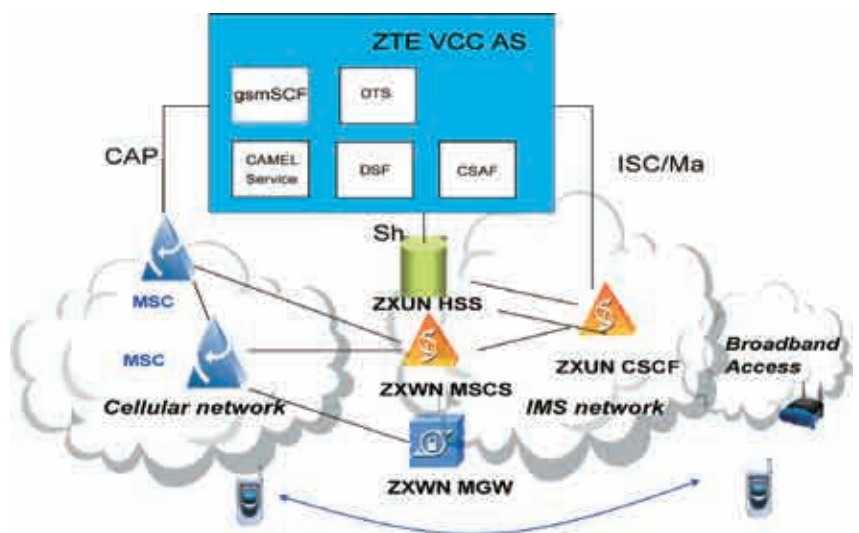

Fig. 1 ZTE's IMS-based VCC solution

ETSI TISPAN, 3GPP, and 3GPP2 standards, it adopts SIP as the control protocol and supports various access methods. The major IMS products include:

- Session Controller (ZXUN CSCF): Service control, service triggering, and etc.
- User Profile Server (ZXUN HSS–Home Subscriber Server): Storing the user profile such as identifier, user authentication data, and etc.
- Media Gateway Controller (ZXWN MSCS) and media gateway (ZXWN MGW): Interworking with a CS domain. They play an important role in the VCC procedures since all inbound and outbound calls of the CS domain will go through the MGCF/MGW.
- Media Server (ZXUN MRF): Media stream mixing, transcoding, and etc.
- Policy Server: Perform policy-based resource control for IP network.

ZTE can provide a complete end-to-end IMS solution that has a migrating path to FMC. All the IMS elements are based on ZTE’s universal all-IP hardware platform which supports smooth migration and protects existing infrastructure investments.

CS infrastructure

Usually the carriers have already deployed the CS networks. The VCC solution has little requirements on CS domain.

VCC application server

The VCC application server (AS) is a key component that accomplishes the call anchor and domain transfer

Link

According to ZTE vice president Fang Rong, the company’s approach to meeting the IMS and VCC needs of its operators is not just limited to an end-to-end strategy, as some competitors are offering, but is “across the board.”

“Our strategy is to deliver what the customer wants, when they want it and within the customer’s budget specification. The products we supply are highly customisable and support all the usual standards, including 3GPP, 3GPP2, TISPAN, ITU-T and OMA,” she said.

“Furthermore, because our technology is based on ZTE’s tried and tested all-IP hardware platform, it can provide a Unified Subscriber Profile Platform (USPP) environment that allows customer data to be used for all aspects of telecommunications service provision, regardless of whether the operator is supplying service on a wireline or wireless basis, or using one of the new hybrid topologies that carrier customers are increasingly asking for,” Ms Fang added.

procedures. ZTE’s VCC AS serves as a SIP AS that connects to IMS via a standard ISC interface. It also acts as the gsm Service Control Function (gsmSCF) for the CS domain.

ZTE’s IMS-based VCC solution only requires the addition of a VCC application server to the IMS network. This means that no modification is required for other network elements (including those in the IMS and CS domains), giving operators a simple and smooth evolution to VCC.

ZTE’s VCC AS is built on the company’s highly successful unified service platform, ZXUP10, which has been deployed globally. The traditional SCP functionality is already present in this platform. In addition, it provides the support for multiple interfaces, multiple protocols, and different types of networks such as 3G, and IMS.

It is worth mentioning that the ZTE

VCC solution can not only support handover between GSM and WLAN networks, as shown in Fig. 1, but also handoff between CDMA1X and WLAN networks.

Conclusion

For a technology as complex as VCC, many outstanding issues still remain. For example, the interaction with supplementary services and multimedia services has become a critical issue for the industry. ZTE’s technological solution is to create an integrated IMS-based VCC system that explicitly meets the current needs of clients, but with the important provision of being customizable to meet the future needs of customers. It is the customizable aspect of ZTE’s IMS-based VCC system that makes its solutions stand out from the competition.

ZTE TECHNOLOGIES



ZTE's Core Network Migration Strategies Towards IMS

Tian Qinping



The fierce competition in the telecom industry, as well as the increasing customer demands for service experiences are compelling operators to find out a more reasonable and cost-effective way of providing a highly efficient, high speed and stable network, as well as a fast, flexible and powerful service platform.

Under such driven forces were the

concepts of “network convergence” and “service convergence” conceived, helping to propel the inception and development of IP Multimedia Subsystem (IMS) technology.

At present, IMS is generally regarded as the direction of the future network evolution and is a key enabler of Fixed-Mobile Convergence (FMC). The deployment of IMS is based on the readiness of standards and equipment. When it comes to actual deployment, operators should make a comprehensive analysis of the existing network resources and end-user demands for service.

Time to introduce IMS

IMS, being widely accepted by the industry as the NGN core network architecture, can help operators construct a unified platform of network and service convergence, effectively reducing their total Capital Expenditure (CAPEX) and Operational Expenditure (OPEX), as well as providing differentiated and individualized multimedia services to customers.

Deploying an IMS architecture requires each individual operator to make a reference to their existing assets. In fact, it is also dependant on the maturity of IMS standards, and products, as well as services.

- **Status of standards:** The current IMS standards are developed by international standard organizations such as 3GPP, 3GPP2 and TISPAN, all of which have released their own IMS specifications. For examples, 3GPP Release 6 was frozen by the

end of 2004; 3GPP2 published the standards for Version 1.0 Rev. B; and TISPAN published its NGN Release 1 specifications. These three standard bodies are now working in closer cooperation for one single standard of IMS, greatly reducing barriers in standards implementation.

- **Equipment availability:** Mainstream manufacturers have all launched their own IMS solutions. ZTE, the fastest growing global provider of telecommunications equipment and network solutions, has developed an end-to-end IMS solution—ZIMS, which includes IMS core, access equipment, terminal, and delivery platform. ZTE has successfully completed extensive IMS interoperability testing while participating in the Global MultiService Forum Interoperability (GMI) 2006 event. In addition, it served as the sole IMS network supplier to a leading mobile operator in China.
- **Service maturity:** The standard body has defined three IMS service modes, among which, using SIP for services like Presence, IM, and PoC are fairly mature. One of China’s leading operators has exclusively selected ZTE’s Soft Digital Assistant (SoftDA)—an IMS client that integrates multiple IMS applications like IM, Presence, group list management, and whiteboard—for enterprises.

As the future core network solution, IMS is ready to be deployed, as determined by the readiness of

standards equipment and services. Operators, leveraging the existing networks, can launch IMS-compliant services to lay a foundation for large-scale IMS applications.

Core network migration strategies

Below is an analysis of how to incorporate IMS elements in mobile networks, fixed networks, and full-service network.

Mobile networks

Since IMS network is a core network convergence solution that simultaneously supports multiple services, the mobile operator who possess GSM, 3G and CDMA licenses should not only be concerned about the evolution trend of a certain type of network, but should also be selecting a network from the existing ones to phase in IMS so that the other networks of the operator shall gradually be converged into the IMS architecture. The present feasible mode is:

- Firstly, build a GPRS overlay network over the existing GSM circuit-switched network to provide end-to-end packet data services.
- Secondly, introduce the mobile softswitch technology to

reconstruct the GSM circuit domain by separating the control layer from the bearer layer; deploy ZTE's unified service platform (ZXUP10) for provisioning a range of multimedia services.

- Then, utilize the PS domain for IMS, so that the Iu interface, between the core network and RAN, is based on IP; the original service platform, ZXUP10, can be kept.
- Finally, the existing CDMA, fixed, and WiMAX networks will gradually evolve into IMS, creating a multi-service, multi-access network.

ZTE provides mobile softswitch that allows a seamless evolution to IMS. Its basic features are illustrated as follows:

- ZTE's mobile softswitch equipment is based on its self-developed V3 unified platform. The functional elements of ZTE's mobile softswitch system can move to the Proxy-Call Session Control Function (P-CSCF), Serving-CSCF (S-CSCF) and Interrogating-CSCF (I-CSCF), and Breakout Gateway Control Function (BGCF) in IMS without a hardware update. Furthermore, the Media Gateway Control Function (MGCF), IP multimedia media gateway (IM-MGW) and Home Subscriber Server (HSS) functional entities can be evolved from MSC Server, MGW, and HLR respectively, saving operators' investments.
- The same physical component of the IMS architecture can implement multiple logical functions. For instance, the ZXUN CSCF supports

the features of P-CSCF, I-CSCF, S-CSCF and BGCF functions. The above logical functions can be mapped to a single device or dispersed across the network, depending on the network scales.

Fixed networks

Fixed operators for traditional PSTN/ISDN services bear upon a great deal of pressure—cross-elastic effects of mobile services, the emerging use of Peer-to-Peer (P2P) applications, incapability to provide customized services, outdated equipment, and fast growth in traffic—that do not bring any increase in profit.

Now, many fixed operators around the world have started the deployment of softswitch systems on a large scale for replacing traditional switch, actualizing network intelligence and implementing new services. From a current network evolution perspective, the fixed network softswitch will evolve towards IMS-compliant TISPN NGN architecture.

ZTE's softswitch system supports smooth migration. It has the following features:

- ZTE's softswitch system can evolve to fulfill functions in IMS: CSCF, MGCF, Access Gateway Control Function (AGCF), and PSTN/ISDN emulation/simulation subsystem (PES/PSS).
- The softswitch systems are recommended to evolve in a step-by-step manner based on the existing conditions. For examples, the softswitch system for long distance voice traffic can migrate to



the I-CSCF and S-CSCF; the local exchange softswitch can evolve to the P-CSCF. ZTE's softswitch provides a migration path for these network evolution solutions.

- During network evolution, the original softswitch networks will be used for voice, while IMS will be the architecture for broadband multimedia services. ZTE's softswitch system can seamlessly interconnect with the IMS system.

Full-service networks

For full-service operators, IMS is easier to implement and is better adapted to service demands in the context of mobile networks than in that of fixed network softswitch. They can use the following solution to evolve to IMS-based network convergence:

- Introduce IMS into mobile networks. Leveraging ZTE's ZXUP10 unified service platform, operators can provide some of the emerging multimedia and popular applications (PTT, IM and Presence) to mobile subscribers. While IMS is placed into large-scale use, peer-to-peer (P2P) style applications will enable fast development of wireless IMS applications. The early IMS can interconnect with the fixed softswitch based on broadband access networks to give broadband subscribers access to some IMS-based services, while some fixed and mobile converged services can be tried.
- Once the IMS wireless networks have realized scale operation, service interworking is no longer enough for developing converged



services. The key to meeting this challenge is a unified service platform and a unified control method. The original unified service platform, ZXUP10, can be kept. While interworking with a softswitch solution, IMS can renovate or replace the fixed network elements that provide control and services. However, IMS cannot replace traditional networks like PSTN, ISDN and circuit switched mobile networks. Instead it will coexist with them for a long time until all legacy voice traffic migrates to IMS.

- Eventually, as IMS-based services develop, the existing fixed and mobile networks will evolve towards a full IMS implementation: deployment of IMS on the fixed network side and convergence of fixed and mobile core networks.

Conclusion

As there is no 'one size fits all' solution, ZTE provides customized solutions for IMS core network evolution according to operators' current network status, and assist them in stepping towards an IMS-converged core.

ZTE TECHNOLOGIES

IMS: A Catalyst for Convergence

Li Na

Convergence—The trend

The dream of one phone, one number, one address book, and one voicemail is ready to come true with the advent of IMS technology. Users can have cost-effective high-speed connectivity in home or office environment, and mobility on external field. The lines between fixed and mobile networks are blurred, and voice-only or multimedia sessions can handover seamlessly between different access technologies.

It is a fact that the communication network is moving toward a packet-based network, especially the IP-based packet network. In this new realm, the terminals are becoming more and more

intelligent. If the operators are content with the status quo, intelligence will be in the terminals with the networks being dumb. The dumb networks can hardly become a star performer in terms of revenue generation.

If the operator does not want to simply act as a pure pipe provider, they must find a means to combine network intelligence with terminal intelligence. The users may enjoy greater communications freedom and more gratifying services, which an intelligent terminal or an intelligent network alone can not possibly achieve.

One necessary condition that allows user to enjoy superior communication



services is that services are access independent, enabling seamless handover between those access technologies.

It is possible to provide reasonably good communication services with mobile networks alone. In this case, the mobile networks need to have excellent coverage and high-speed data capabilities, which are very expensive propositions for operators.

The concept of Fixed-Mobile Convergence is introduced to reduce the CAPEX while providing good services. The cost effective fixed access technology can be used to reduce the burden on the mobile access link, and to increase the overall network coverage whenever possible.

This mechanism to reduce costs without compromising the quality of communication services is popularly known as FMC—Fixed-Mobile Convergence.

IMS—The technology

The IP Multimedia Subsystem (IMS) technology was originally designed for multimedia session control in a mobile environment, and was further enhanced to support the fixed network.

For communication to occur between multiple parties, session control is essential to ensure connectivity and Quality of Service (QoS). The session control layer has traditionally been bonded with specific access technology and specific services. The beauty of IMS is a session control layer that's independent of its access layer as well as services

it can provide. On top of that, mobility and security have been taken into account since IMS was conceived.

IMS utilizes the IP-based transport packet mechanism while avoiding the pitfalls of IP network by exerting rigorous session control over conversations. With the IMS, a common IP network is translated into a controllable, chargeable, packet-based communication network with revenue generation potentials.

By using the IP technology, the intelligent terminals are readily available, and can meet the requirements of IMS with only minor modifications necessary. Moreover, IMS can realize network intelligence with abundant IP-based applications associated with Information Technology (IT). By bridging the gap between network intelligence and terminal intelligence, IMS offers the users superior communication experience, and a variety of life styles.

ZTE's IMS/FMC solution

ZTE's IMS Solution (ZIMS) is compliant with 3GPP IMS, 3GPP2 Multimedia Domain (MMD), as

By bridging the gap between network intelligence and terminal intelligence, IMS offers the users superior communication experience, and a variety of life styles

well as TISPAN extensions for use over fixed networks. It encompasses terminal, access network, core network, and service platform.

The IMS technology is access-independent, as discussed previously, and the ZIMS has proven interoperability with various access technologies including WCDMA, TD-SCDMA, CDMA2000, WLAN, WiMAX, Cable Broadband Access, and xDSL.

The ZIMS comprises all functional modules defined by 3GPP, 3GPP2, and TISPAN. This solution enables the subscriber to use either a fixed access terminal, or a mobile terminal, or a terminal supporting both access technologies. The notion of a fixed subscriber and a mobile subscriber do not exist here.

One of the key challenges in this new era is interoperability. This challenge arises from the separation of the control and bearer layers, the introduction of various functional components using open interfaces. In GMI 2006 organized by MultiService Forum (MSF) in October 2006, ZTE's Call State Control Function (CSCF) and Home Subscriber Server (HSS) equipment have demonstrated excellent interoperability among all the participants.

In the service arena, the ZIMS provides a proven service delivery platform (ZXUP 10) that is based on the SIP application server, the OSA application server, and the CAMEL IMS Service Switching Function (IM-SSF). This platform allows easy integration with third-party systems,

easy interfacing to legacy hardware, and a variety of billing mechanisms defined by 3GPP.

The ZIMS also facilitates an Integrated Multimedia Environment (IME) to provide a wide range of multimedia services such as Instant Messaging, Presence, video/audio conference, multimedia ring back tone, dynamic phone book, application sharing, and group list management. ZTE's IMS client, Soft Digital Assistant (SoftDA), is an intelligent terminal that supports all the applications created in the IME.

To ensure a consistent user experience, the ZIMS (IME in particular) implements the Service Capability Interaction Manager (SCIM) function which enables interaction between services.

A common network element is defined so that policy and resource management functions that bridge the service and bearer layers, can be shared across both the fixed and mobile access networks. The policy element, and the resource management element, when coupled with the flexible charging element, can provide dynamic QoS which enables competitive differentiation.

The session border controllers in IMS that address the service delivery security issue, provide control at the access segment and at the inter-provider connection

edge.

The ZIMS supports all the authentication mechanisms, including the standard IMS AKA, early IMS authentication, and implicit authentication based on fixed network access point.

The solution also supports a wide variety of terminals, including SoftDA, IMS UE (3G handset), SIP IAD, SIP conference terminal, ZX Home Gateway; both the online and offline charging models; a unified

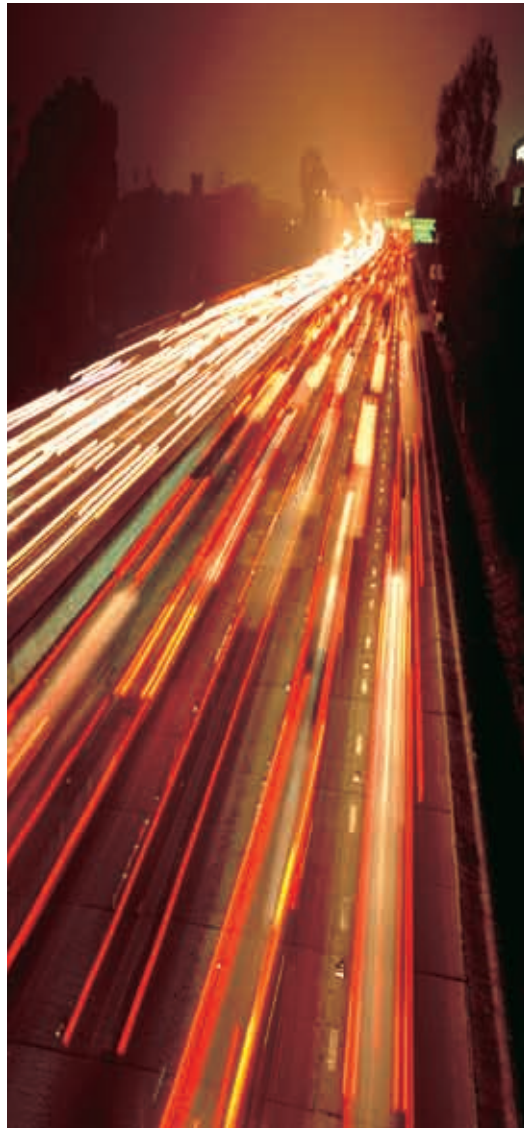

management system; and a modified OSS system.

The solution features flexible product mapping and scalability. ZTE's IMS hardware platforms use the universal high-performance hardware platform, on which all ZTE's products are based.

ZIMS-Value proposition

With several decades of expertise in international telecoms, as well as a good understanding of trends in the communications industry, ZTE has developed an economical ZIMS solution. It has the following features:

- A complete end-to-end solution that includes terminal, access network, core network, and service delivery platform.
- 3GPP/3GPP2/TISPAN/ITU-T/OMA compliant.
- Based on a universal all IP hardware platform.
- Customizable.
- A multimedia service platform for creation, execution, and management of services.
- A unified subscriber profile platform (USPP) for the management of user data.
- Support for various access technologies.
- An open terminal platform and various multimedia terminals.

The ZIMS offers a cost-effective, customizable approach to distribute intelligence to the terminals and the networks at the same time, allowing operators to deliver advanced services to an increasingly multimedia-aware audience.

ZTE TECHNOLOGIES



ZIMS—Open, Tried, and True!

Larry Ma, Lee Weijun, Dick Chen, Mo Li

The IMS promise

IP Multimedia Subsystem (IMS) promises an open architecture that can reduce operational expenses and support a vast array of revenue generating services. To fulfill these objectives, equipment from different vendors has to be compatible and be able to interwork with each other in accordance with the protocols defined by standard bodies. Interoperability Testing (IOT), as an important measure, can be conducted to validate the compatibility of the IMS equipment.

As a global leader in providing next generation telecommunication equipment and network solutions, ZTE has participated in a large-scale IMS interoperability testing and earned a reputation for its high-performance IMS solution (ZIMS). Its IMS platform is designed with fully open interfaces, flexible configuration, and standard compliance in mind

Success at the GMI 2006

By October 2006, ZTE has successfully completed extensive IMS interoperability testing with more

than 20 global leading IMS vendors while participating in the Global MultiService Forum Interoperability (GMI) event at Verizon's lab in Waltham, Massachusetts, USA.

The 2006 GMI event focused on testing multi-vendor interoperability to achieve Fixed-Mobile Convergence and to support IMS service framework. By moving IMS from theoretical functional modules to physical realization, the GMI 2006 provided a realistic view of what it would take to transition to the next generation all IP

network.

The event organized by MultiService Forum (MSF) was the telecommunication industry's first multinational, distributed, interactive test bed to verify key interoperability aspects of IMS implementations. The event was jointly hosted by five of the top international operators—British Telecom, Korea Telecom, NTT, Verizon and Vodafone—and The University of New Hampshire Interoperability Laboratory. Fig.1 demonstrates the GMI 2006 network.

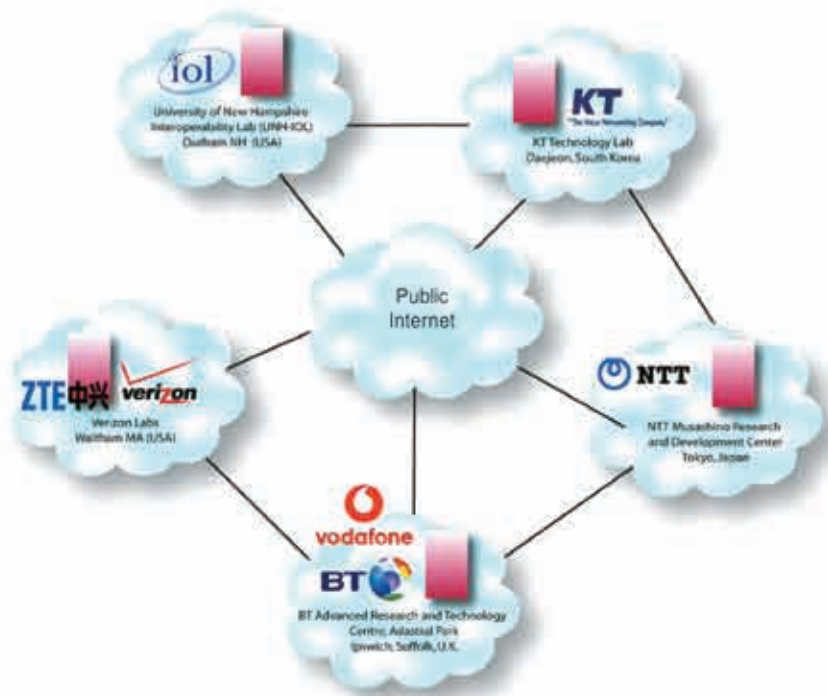

Fig. 1 GMI 2006 network

(Source: MultiService Forum (MSF) White Paper, “Validating IMS: The Practical Implementation of Converged Networks”)

As a leading IMS solution provider, ZTE provided its P/I/S-Call Session Control Function (CSCF), Breakout Gateway Control Function (BGCF) and Home Subscriber Server (HSS) equipment. ZTE successfully participated in all six test scenarios specified by the MSF, including roaming services across multiple network types, Quality of Services (QoS)—with Session Border Controller and Bandwidth Manager—3GPP IMS & Mobile Core Network Interoperability, IP Carrier Interconnect/Internetworking, Security interoperability, and 3rd party applications and service

brokering.

The intensive two week testing has verified interoperability between ZTE’s IMS products with other vendors’ CSCF, HSS, Application Server, Session Border Controller, Bandwidth Manager, MGCF, Parlay Gateway, Media Gateway, SIP and IMS terminals. ZTE’s success at the GMI 2006 demonstrates the compatibility, flexibility and reliability of its IMS product portfolios, as well as its dedication to the IMS technology; and this success is also a testimonial of ZTE’s capabilities in providing next generation networks equipment to operators around the world.

Success at operator’s trials

A vendor can test the cross-vendor interoperability through field trials or IOTs organized by operators where its equipment is validated in real-world scenarios.

ZTE, with its renowned ZIMS solution, has been exclusively invited by several leading global operators to participate in their testings and trials.

Tests for multiple network elements are included. The tested elements of ZIMS solution include S/I/P-CSCF, HSS, Application Server, MGCF, Media Server, Media Gateway, Parlay Gateway, Charging Function, and a variety of SIP and IMS terminals.

Take, for instance, the trial ZTE conducted with one of China’s leading mobile operators. Both its infrastructure equipment (core equipment and service platform) and its terminals (SoftDA and IMS compliant handsets) were tested. Moreover, ZTE’s Soft Digital Assistant (SoftDA) was chosen by the operator as the reference terminal.

Enabling third party applications

Applications are always the most important drivers of network evolution and a major source of revenue for operators. An open service creation platform will act as the catalyst for the delivery of innovative services.

ZTE commits itself to helping the operators in providing any services that the end-user demands. To fulfill this commitment, it has been working closely with some leading IMS service providers to create an IMS service industry chain. ZTE develops

GMI 2006 Declared a Success

By Carol Wilson, Oct 26, 2006 *Telephony*

A two-week test of IP multimedia subsystem interoperability is concluding this week and participants led by the MultiService Forum today declared the effort successful. The test, known as Global MSF Interoperability 2006, was conducted at five sites globally including Verizon's Waltham Labs and the University of New Hampshire Interoperability Labs.

Other participants included BT's Advanced Research and Technology Centre and Vodafone in the U.K., the KT Technology Lab in South Korea and the NTT Musashino Research and Development Center in Japan. One key accomplishment of GMI 2006 is getting IMS closer to actual implementation,

said Mark Wegleitner, senior vice president and CTO of Verizon, which hosted an MSF press event today.

"The number one thing is a strong standards foundation," he said. "If we can provide that, we make a contribution and then we take it to the next step. That is what GMI 2006 is all about. We are seeking the right formula for implementable standards. That's what GMI 2006 is about. Option settings on a single network element could product an uncountable number of variations to what is supposed to be a standard element. One reason for GMI 2006 is to narrow down the options, so we can focus on what we should focus on, which is additional functionality."

an open ecosystem based on standard interfaces around its truly open IMS application platform, to encourage "the best of the bests" deployments to facilitate integration with third-party applications, and to create a "plug-and-play" environment for service providers. ZTE has demonstrated its "plug-and-play" open service platform in a number of trials with its partners.

ZTE's IMS service platform can also support interfaces such as CAP

and INAP in order to provide service continuity when the migration to new IMS networks takes place. Moreover, the ZIMS, featuring flexible configuration and modular design, can easily be configured or changed to cater to each operator's unique requirements, enabling smooth migration of the existing revenue generating services onto the new IMS service platform.

By frequently conducting interop testing with many leading service

content providers and service platform providers, ZTE aims to provide operators the best benefits from a "plug-and-play" environment.

For a testing that ZTE jointly conducted with its partners for the media sharing applications, ZTE provided its entire IMS network infrastructure, including the P/I/S-CSCF/BGCF, the MGCF/MGW, and other network edge equipment, while ZTE's partners provided the Application Server, the Media Server, terminals, and the WM5 IMS client.

Open, tried, and true

The ZIMS has tremendous potential to reduce both operational expenses and capital expenses for operators. It gives an operator the freedom to select components of its network from different vendors, to differentiate its service content provider from its service platform provider, and to introduce services much faster, yet at a lower cost.

To maximize the benefits of the open IMS architecture, an operator needs to look at a potential vendor's IMS solution, and both its IOT records and references.

ZTE, a leader in providing next generation network solutions, has been engaged in large-scale and global interoperability testing events such as GMI 2006 as well as exclusive trials with a number of leading operators. With an open IMS ecosystem approach, ZTE delivers its customers a true "plug-and-play" experience, while dramatically reducing their costs and development time.

ZTE TECHNOLOGIES



SDMP: A Common Platform for IMS

Su Jie

IP Multimedia Subsystem (IMS), which supports IP Connectivity Access Network (IP-CAN), was first specified by the Third Generation Partnership Project (3GPP) in order to facilitate the creation of multimedia services in UMTS networks. Initially standardized in 2001, IMS has evolved over the past years (R5, R6, R7, and R8) and can support multiple IP access technologies. As it is access-independent, IMS is recognized as the basic platform that ignites the next generation network convergence, and with the introduction of multimedia session control into the all-IP network environment, it operates with carrier-grade attributes for the provision of multimedia services.

As a total solution provider, ZTE attaches great importance to IMS technology, and deems it as a strategic necessity for NGN. IMS is especially suitable to the integrated operators, as it allows them to provide a multitude of converged and differentiated services over multiple networks, as well as cut their CAPEX and OPEX expenditure.

The launch of new services is a key driver of IMS. The IMS service architecture should be standard and can be easily scaled to accommodate future network development. ZTE applied this idea in its IMS-based unified and open service platform—

Service Delivery & Management Platform (SDMP). The SDMP enables the sharing of network resource and service applications, faster time-to-market, and abundant multimedia services. It is composed of service execution platform (SEP), as well as integrated service management platform (ISMP).

Service execution platform

The SEP hosts a Parlay Gateway for the creation of data, VoIP, and FMC services as well as the migration of legacy services, running on the existing SCP IN platform. Furthermore, the SEP provides IPTV service execution function. At present, the SEP supports protocol adaptation (e.g., INAP, CAMEL, SIP, MGCP, IMAP & SMTP, and SMPP).

The design of SEP is based on the ZXUP10 (Fig. 1), the 3rd generation unified service platform launched

by ZTE. The ZXUP10 is a standard-based, IMS-oriented NGN solution that supports the Parlay/OSA platform, the SIP application server, and the traditional intelligent networks, which help operators to build a brand new service provision mode.

Features of ZXUP10

- Supports three standard application modes: the OSA/Parlay gateway; the SIP application server; and the IP Multimedia Services Switching Function (IM-SSF) to facilitate the use of IN services.
- Provides standard and open interfaces so third parties can develop applications, dynamically responding to changes in market. New players—SPs—can easily take part in the value chain.
- A horizontal architecture which enables the sharing of network resource and service applications.

- Abundant capability sets for IN services from both the CS and PS networks.
- Adapts multiple protocols which include SIP, CAMEL, INAP, WIN, MGCP, SMPP, and so on.
- Supports the ISC protocol used in IMS, and the CAMEL protocol for GSM, allowing simultaneous service delivery across different networks.
- As it addresses both IMS-based multimedia services and traditional IN services, operators don't need to modify the service platforms for new applications when upgrading the core networks.
- Incorporates a flexible charging mechanism, which supports period, stream, content and QoS parameters, and etc., as well as packaged offerings to different operators.
- Embedded with the IM-SSF function, which provides service interworking between the IMS and legacy networks, allowing IMS users to access traditional IN services.
- The Parlay gateway works with application server (AS)—a distributed architecture, which means workload may be distributed across different ASs, avoiding congestion and ensuring the safety of the system.
- The platform defines four levels of overload control, and high availability is achieved (99.999%) through redundancy.

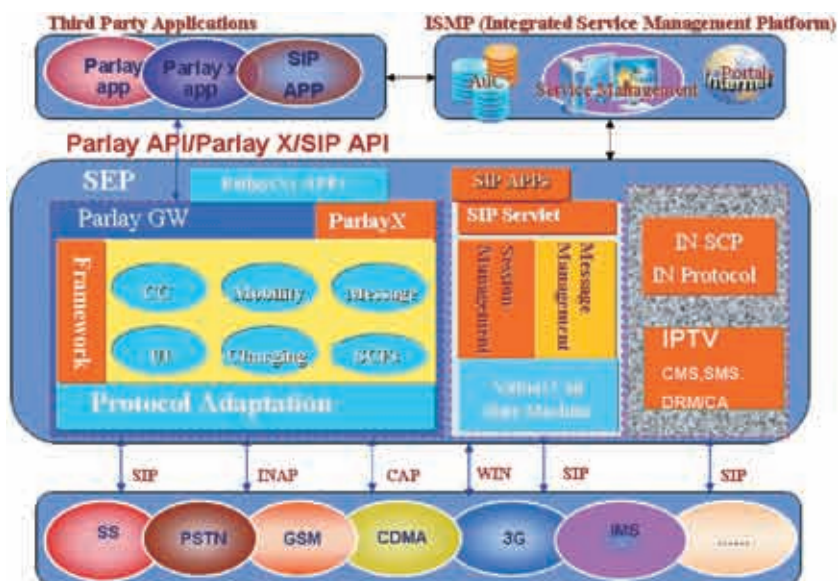

Fig. 1 Architecture of the ZXUP10 system

Integrated service management platform

ZTE has launched an integrated

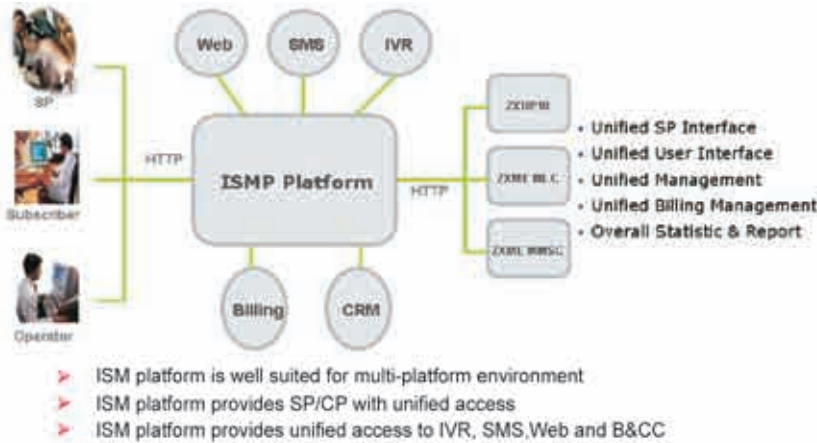

Fig. 2 ISMP platform

service management platform, providing a flexible, fast, high efficient and multifunctional environment for IMS services launch. It separates the operational support functions such as charging, authentication, subscriber management, and service management from the basic service capability. All the services provided by the SEP can be managed by ISMP.

The ISMP provides unified service management functions such as authentication; billing; user, SP, service, content management; and Operation & Maintenance (O&M). It is essentially a data and management center for operation and control.

The details of the ISMP functions are presented as follows:

- Empower subscribers, SPs/CPs and operators to operate and manage various services via WEB, WAP, SMS and voice portals.
- Subscriber management including self-registration, basic subscriber information management, and subscriber group management.
- CP/SP management has two

dimensions: basic CP/SP information and CP/SP life cycle.

- Service management falls into two types: basic service information management and service life cycle management. The basic service information can be managed through the CP/SP self-service portal. The service life cycle is divided into a sequence of phases: service application, service test, service release, service suspension, service modification, and service de-registration.
- Comprehensive management over the whole system including the department, staff, the role, and the operator.
- Service contents such as SMS, CRBT, and streaming contents can be managed in a unified way. Meanwhile the ISMP supports content life cycle management, content packaging, pricing, service binding, and portal content display.
- Authentication of SPs, services, subscribers, subscription, portal redirection, and service capability

activation.

- Provides flexible billing schemes, for instances like: billing based on time, traffic, and usage in addition to various discounts (discount for a usage, subscriber type, or special time segment).
- Manages terminals including adding, deleting, modifying and querying terminal type and capability information. It provides interfaces that allow external entities to query and modify subscriber terminal type information in real time and implement terminal adaptation.
- Statistical analysis of CP/SP, service, subscriber, portal, and billing information. The system can generate parameterized reports, routine reports, and statistics reports.

Conclusion

With the shift towards multimedia services and all-IP network, the operators need to avoid becoming solely bit pipe providers, and increase their control over services. The introduction of SDMP makes it easier for operators to compete against internet service providers, and to maintain their primary position in the value chain.

The SDMP provides a horizontal architecture that enables operators to deliver and manage multimedia services over multiple network types in a uniform way. ZTE offers a standard-based, best-in-class, and carrier-grade SDMP solution to wireless, wireline, and integrated operators. ZTE's SDMP as a versatile service engine can be tailored to each operator's specific requirements.



ZIMS—Advancing Dynamic QoS

Mo Li, Chief Architect of ZTE USA

Introduction

Ensuring Quality of Service (QoS) has been a persistent topic in the packet-based networks. The QoS mechanism provides the ability to systematically discriminate between the packets inside a network. Such discrimination is normally based on the services intended to be provided by the network.

For service providers, QoS serves as a tool for competitive advantage. The competitiveness can be achieved through offering users improved legacy services or real-time services which would be very difficult to implement (e.g., on-line gaming) without the QoS mechanisms.

There are many reasons why the QoS issue is difficult to resolve. In an IP-based network, the intelligence residing in the network is very limited. In particular, the concept of “session” is very weak, if it ever existed. In this sense, it is impossible to provide QoS for a set of connectionless packets.

After years of research, two major types of QoS mechanisms have been developed. One is to provide stringent QoS assurance (e.g., RSVP) and the other is to provide relative QoS (or CoS—Class of Service).

For stringent QoS control, the traffic

source needs to have the ability to precisely describe the traffic in terms of arrival curve in network calculus. This is a very strong requirement on the traffic source and is not attainable without loss of information at the source (in lieu of possible information loss during transit).

There is no need to provide traffic description at the source for achieving relative QoS (CoS). On the other hand, the parameters associated with QoS, such as delay, jitter, and loss ratio can not be assured.

For a network operator, it is desirable to have those two types of QoS mechanisms offered to their customers. For demanding customers, stringent QoS would be provided with specific characteristics of incoming traffic, and specific performance assurances.

For the majority of customers, relative QoS would be a reasonable approach for its simplicity and scalability.

The concept of session needs to be introduced for QoS assurance and charging purposes. In the IP world, RSVP introduced this concept with an explicit objective of providing QoS for the IP flows. Unfortunately, RSVP has proven to be not scalable and its public

deployment is rare.

With the advent of IP Multimedia System (IMS), the network does integrate the concept of session. In this case, other network architectural components (such as RACS—Resource Admission Control System) have also been introduced to tackle the QoS issue. RACS is the ITU-T/ETSI TISPAN subsystem responsible for policy control, resource reservations and admission control. It provides applications and/or subscribers a mechanism to request and reserve resources from the access network, thereby enabling operators to enforce admission control on a per session basis.

In this paper, ZTE’s approach to tackle the QoS issue, part of its IMS solution—ZIMS—is presented. In ZIMS, the Diffserv network, the IMS, the RACS, and the interactive charging system are used cooperatively to offer a solution to the QoS issue. In particular, the Diffserv network and IMS are bridged by the RACS and interactive charging system for policy enforcement and revenue collection.

Dynamic QoS—Issues and solutions

There are two issues that affect the user’s experience in the packet-based

communications. One is the QoS issue, which deals with the packet delay, packet jitter, and packet loss caused by the “store and forward” packet switches and/or routers.

The other issue is about ensuring conformance to the traffic characteristics negotiated between the traffic source and the networks (e.g., traffic shaping is used at the source so that the resulting traffic conforms to the arrival curve specific to an interface, or a codex with low bandwidth requirements).

In order to solve both issues related to user experience, the Diffserv approach is introduced in the NGN environment. The major advantages of Diffserv are its scalability and availability.

For bandwidth assurance, certain DiffServ Codepoint (DSCP) values for DiffServ packets are subject to bandwidth reservation constraint (i.e., admission control). In this case, a particular DSCP value is associated with specific bandwidth (e.g., using weighted fair queue with weight specified for a service class).

Whenever a reservation mechanism is invoked, the network will establish a session state associated with the reservation which clearly has scalability implications. Some reservation mechanisms mandate such reservation on an almost per-nodal-station basis, while some mechanisms do on certain key networking elements (e.g., IMS and RACS).

Furthermore, it is also possible to enforce reservation at the concerned border nodes only. Those border nodes

may send probing packets to initiate the reservations, and subsequently keep them.

But the Diffserv network alone can not resolve these two issues. Without cooperation between users inside the network, there is no assurance of alleviating impairment to the network. For example, if everybody is using the EF scheme (Expedited Forwarding—the highest priority class in Diffserv), the network will have similar performance in the case of everybody using the Best Effort (BE) class of service. In general, the user cooperation in the IP-based networks can not be assumed to be voluntary.

If no voluntary user cooperation can be assumed and the network needs to resolve both issues, a forced cooperation is mandated. The tools to enforce such cooperation would be the session and charging control that are the strengths of IMS and RACS-based networks.

For reducing user experience

impairment introduced by the network, the user may reset its requested DSCP value (e.g., request the sender to adjust its DSCP value in SDP). Every such adjustment will have monetary implications, given the session control, media flow control, and charging capabilities of IMS and RACS. For an example, a VoIP user can adjust the DSCP value to improve voice quality.

It should be noted that the initial DSCP (minimum) setting may be decided by the intended services. Any adjustment of DSCP should not be lower than the required minimum queuing threshold and discard the priority implied in the DSCP value.

Once the requested DSCP value is established, which is subject to the admission control mechanism (i.e., reservation), the flows will be allocated with a consistent bandwidth. In this case, the concept of “effective bandwidth” has been used. The flow of messages is illustrated in Fig. 1.

Once the bandwidth reservation

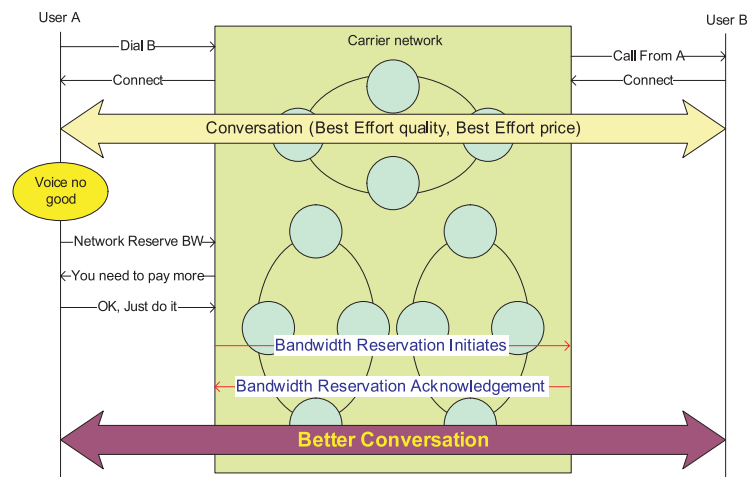

Fig. 1 The flow of messages

request is acknowledged, the conversion quality will not be affected by the other flows inside the network.

If the user experience is still unsatisfactory due to the insufficient effective bandwidth resulting from an insufficient estimation of the delay, jitter, and loss requirements, the reserved constant bandwidth may be adjusted (increase the effective bandwidth) so that the QoS perceived by user can be satisfied. In technical terms, increasing the effective bandwidth is to increase the slope of the service curve, so the delay, loss rate, and jitter can be further reduced inside the network.

In order to resolve the second issue (i.e., poor user experience due to traffic shaping at source or low bandwidth encoding), the signaling can be used to negotiate a new codex or a new bandwidth. When the DSCP value is assigned to the admitted traffic, the new bandwidth will be used for reservations, but not without its monetary implications.

The above mechanisms described can be either static (fixed at the beginning of the session) or dynamic (adjusted during the session). The capability to adjust the DSCP value, the effective bandwidth, and the bandwidth at the source are referred to as the dynamic QoS. It is ZTE's approach to the QoS issue in the NGN environment and is implemented in its IMS solution (Fig. 2).

In Fig. 2, a simple modification of DSCP value is proposed and the high-level messaging is illustrated.

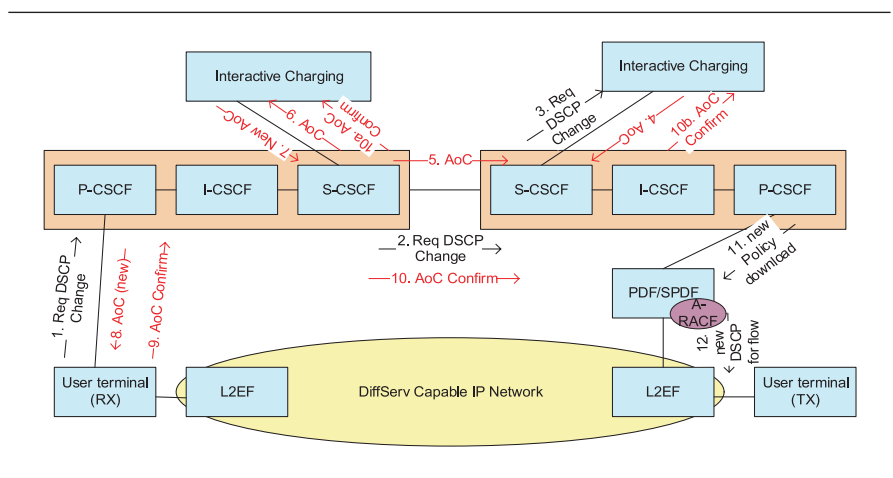

Fig. 2 A working example with IMS network

In generic terms, the possibility of dynamic QoS is realized by the joint efforts of the Diffserv network at the bearer layer, and the IMS at the session control layer. Those two layers are bridged by the RACS (e.g., SPDF, A-RACF, C-RACF in RACS) and the charging mechanisms in the IMS network.

Dynamic QoS–Business implications

The rationale for a carrier to employ the dynamic QoS scheme lies in its inherent competitive advantages for the provision of the best effort service. In today's networking environment, there is no shortage of communication services with free or trivial costs. But those services remain to be the best effort service with no QoS support since there is a lack of business relationships with the service providers.

If the best effort service is not good enough, the user has to endure it instead of getting more resources through monetary means. For example,

the carrier may deploy VoIP services with the best effort assurance at the same service charge as its competitors. Once the user needs a better voice quality, the carrier's customers may invoke the dynamic QoS mechanism while the others are left helpless.

In theory, the dynamic QoS sell networking resources (bandwidth) to the highest bidder in the Diffserv network. Only the customers, paying premium prices, will enjoy guaranteed services.

Remarks

The QoS issue has been around for a long time and its solution seems elusive. In the ZIMS approach, the resolution of QoS issue calls for a Diffserv network at the bearer layer, an IMS network where RACS is required for session control, and an interactive charging system. This approach combines the technology, the monetary constraints, and intended services to provide dynamic QoS support and enhance the operator's competitiveness.

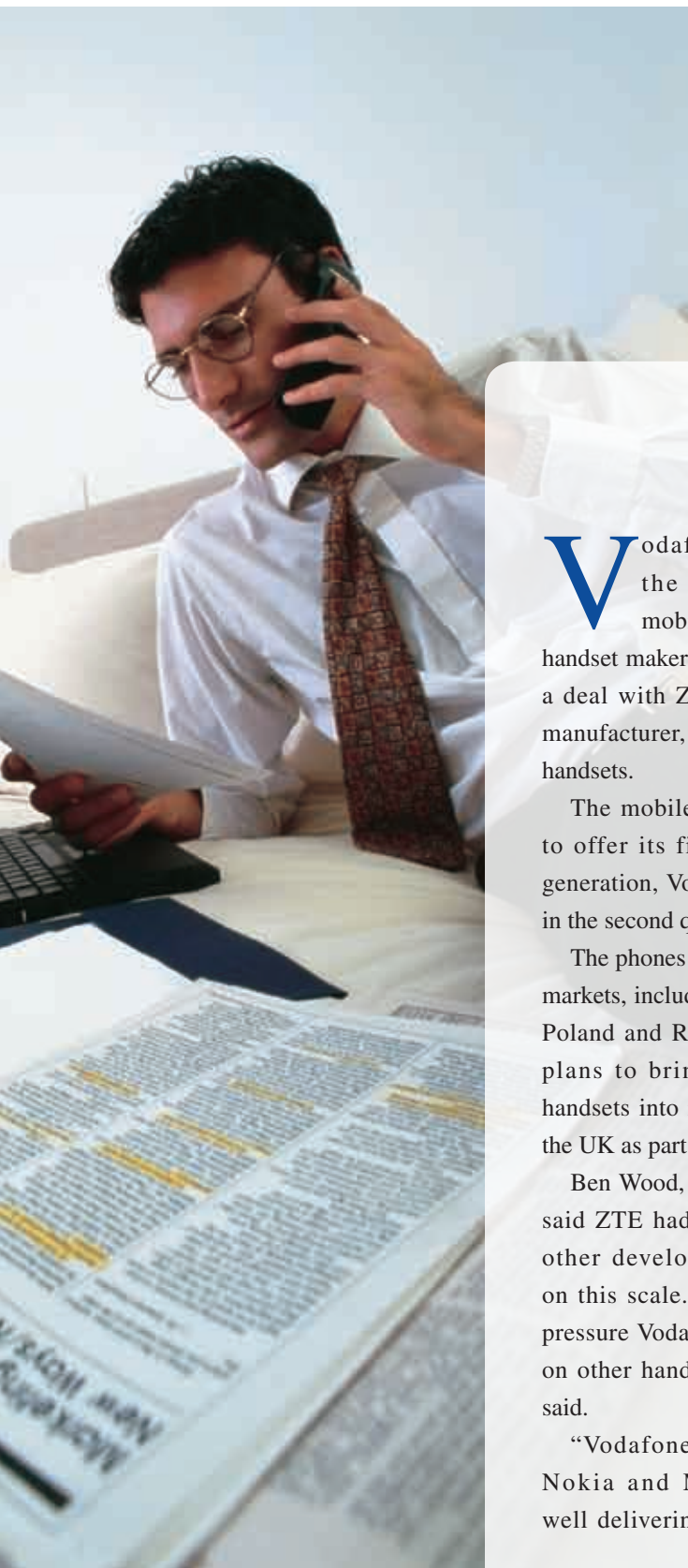

FINANCIAL TIMES

Vodafone Deal Hits Makers of Handsets

By Philip Stafford, Feb 14, 2007 *Financial Times*

Vodafone put pressure on the world's established mobile telecommunications handset makers yesterday by unveiling a deal with ZTE Corp, the Chinese manufacturer, to make ultra-low-cost handsets.

The mobile phone operator plans to offer its first low-cost, second-generation, Vodafone-branded device in the second quarter of 2007.

The phones will be sold in emerging markets, including India, South Africa, Poland and Romania. Vodafone also plans to bring the Chinese-made handsets into mature markets such as the UK as part of its pre-pay range.

Ben Wood, analyst at CCF Insight, said ZTE had done similar deals in other developing markets but not on this scale. "The key thing is the pressure Vodafone is hoping to exert on other handset manufacturers," he said.

"Vodafone feels that, although Nokia and Motorola have done well delivering low-cost entry level

handsets, it believes it is still paying a premium doing deals with these leading manufacturers."

Both mobile phones companies and handset makers are increasingly targeting fast-growing emerging markets to offset declining revenues from maturer US and western European markets.

The handset industry is also seeing the strongest growth coming from emerging markets. Handset makers such as Sony Ericsson are attempting to compete with cheaper phones against the largest manufacturers, such as Nokia and Motorola.

Mr Wood estimated that, if ZTE could supply Vodafone profitably, the deal had "the potential to hit margins" at makers, especially Nokia, the Finnish manufacturer.

He estimated that Nokia produced 45m entry-level phones out of a total production of about 105m in the fourth quarter of last year. He suggested it could accelerate consolidation outside the top five handset makers.

ZTE Gears up for Mobile TV Growth

While the UMTS/HSDPA equipment and IMS converged services have been rolled out last year, mobile TV took center stage at the 3GSM World Congress 2007, the mobile industry's premier event held from February 12th to 15th in Barcelona, Spain.

Mobile TV is one very important application for 3G handsets, and is seen as poised to take off. ZTE is going to ship the first batch of DVB-H handsets to European countries like Italy, giving it a first mover advantage, as well as strengthening its presence in the European 3G handset market.

The mobile TV market is fragmented between different standards: DVB-H in Europe, MediaFLO in the U.S, DMB in Japan and South Korea, and CMMB in China. Adopting a multi-standard approach, ZTE can support any of these standards that network operators

may choose to deploy.

With rich accumulation of mobile TV technologies, ZTE has entered the European high-end market successfully. In September 2006, ZTE and BT Movio signed a contract to cooperate in developing handsets for Mobile TV and DAB digital radio services. ZTE has become one of the first vendors in the world to support DAB-IP technology in its 3G handsets. On the other hand, ZTE initiated contact with China's State Administration of Radio Film and Television (SARFT) after SARFT issued China's self-developed standard for mobile TV, called CMMB. ZTE is now developing relevant mobile phones, preparing for the mass-market adoption of CMMB.

In terms of the 3G handset mode, ZTE has developed handsets with three 3G standards—WCDMA, CDMA2000 and TD-SCDMA. Based on its strong

capability in terminal integration, ZTE has launched a series of dual-mode or even multi-mode 3G handsets. Recently, the company delivered more than 10 types of 3G terminals including handsets—some of which (V820, V720 and V825) boast an ultra-thin profile of about 15mm—data cards, monitors and modems to Taiwan..

While mobile TV handsets are presenting a breakthrough opportunity, its dual mode and multimode handsets are another set of highlights for ZTE to win customers. The 3GSM World Congress served as the warm-up for ZTE before penetrating the European and American high-end markets.



ZTE F908



ZTE GSM exPower SOLUTIONS.

INCREASE YOUR BUSINESS SUCCESS BY REDUCING YOUR TCO.

ZTE's cost-effective GSM solutions provide world class service to over 70 million subscribers in more than 30 countries, and have helped us build strong partnerships with 12 of the world's top thirty telecoms operators:

ZTE's new future-proof GSM solutions are specially designed to dramatically reduce your TCO and can be individually tailored to your specific network requirements to maximise value from your business.

ZTE's ground-breaking technology solutions like the GSM dTRU BTS with NetSpeedy wireless enhancement, the SRRP intelligent resources pool, the

Go-Home FMC Pico BTS and our Almighty-Link IP transmission system enable us to drive down your TCO.

ZTE is the fastest-growing global provider of telecommunications equipment and network solutions.

We deliver innovative, custom-made products and services to customers in more than 100 countries, helping them achieve continued revenue growth, and shaping the future of the world's communications.

Please visit www.zte.com.cn or contact your local ZTE office to know more.

Welcome!

