

Overview of the Mars Sample Return Earth Entry Vehicle

Robert Dillman and James Corliss

NASA Langley Research Center
Hampton, VA 23681

ABSTRACT

NASA's Mars Sample Return (MSR) project will bring Mars surface and atmosphere samples back to Earth for detailed examination. Langley Research Center's MSR Earth Entry Vehicle (EEV) is a core part of the mission, protecting the sample container during atmospheric entry, descent, and landing. Planetary protection requirements demand a higher reliability from the EEV than for any previous planetary entry vehicle. An overview of the EEV design and preliminary analysis is presented, with a follow-on discussion of recommended future design trade studies to be performed over the next several years in support of an MSR launch in 2018 or 2020. Planned topics include vehicle size for impact protection of a range of sample container sizes, outer mold line changes to achieve surface sterilization during re-entry, micrometeoroid protection, aerodynamic stability, thermal protection, and structural materials selection.

Introduction

The goal of NASA's Mars Sample Return project is to bring surface and atmosphere samples from Mars back to Earth for detailed study. NASA Langley Research Center's Earth Entry Vehicle performs a critical role in the mission, protecting the sample container from reentry heating and deceleration loads during atmospheric entry, descent, and landing¹. The basic EEV design presented here was developed in the 1998-2001 time frame for the 2003/05 MSR Project, which was cancelled in 2001 but was followed by technology development efforts through 2004. Mission studies in 2004 called for an EEV system validation flight test in 2010 and MSR launch in 2013^{2,3}. New development studies are underway at the Jet Propulsion Laboratory (JPL) and Langley in support of an MSR launch in 2018, and call for an EEV flight test in 2015 just after the MSR Preliminary Design Review.

Since mission plans do not call for sterilizing the samples before returning them to Earth, sample containment must be maintained for protection of the terrestrial environment. The NASA Planetary Protection Officer established a draft requirement for the 2003/05 MSR Project calling for the probability of releasing a 0.2 micron or larger particle into Earth's biosphere to be less than 10^{-6} . This requires the MSR EEV to function with reliability never before demanded of a planetary entry vehicle. Probabilistic Risk Assessment (PRA) techniques were used to quantify the reliability of design options, and drove many aspects of the mission and vehicle design in order to make the high reliability goal achievable.

MSR Mission Scenario

The MSR mission scenario includes a Mars lander to select surface samples and place them into a container with redundant seals, a small rocket to place the sealed container into Mars orbit, and an orbiting spacecraft to retrieve the container and insert it into the EEV. The Earth-return spacecraft then carries the EEV back toward Earth on a near-miss trajectory; the spacecraft flies past Earth while releasing the EEV on an Earth-intercept trajectory, spin-stabilized at a zero-degree angle of attack. The EEV makes a ballistic entry, survives reentry heating and atmospheric deceleration, and comes to a ground landing. The EEV landing site has not been officially selected, but should include controlled ground- and air-space covering a large area of soft terrain, such as found at several military installations including the Utah Test and Training Range (UTTR) where the Genesis and Stardust entry vehicles landed. After landing and recovery, the EEV and the enclosed sample container are transported to a dedicated sample handling facility.

The EEV's planned Earth entry speed for the 2003/05 MSR Project was 11.56km/s. An entry flight path angle of 25° was chosen to limit the stagnation point reentry heat flux to the 1500W/cm² level achievable in ground test facilities, so that the TPS materials could see adequate qualification testing before flight. These trajectory values will need to be updated for the 2018 mission.

EEV Design

The MSR EEV baseline design, shown in Figures 1 and 2, is a 0.9m diameter blunt body with an Earth entry mass of 44kg, wrapped around a 16cm spherical sample container intended to hold 0.5kg of Mars samples. The EEV forebody is a 60° (half-angle) cone with a spherical nose; the aft side is concave, with a central hemispherical lid that latches in place after insertion of the sample container. The JPL-designed sample container fits in the center of the EEV, inside a 5mm-thick flexible containment vessel that is sealed in Mars orbit before return toward Earth. These multiple, dissimilar containment layers are intended to protect against common-cause failure modes.

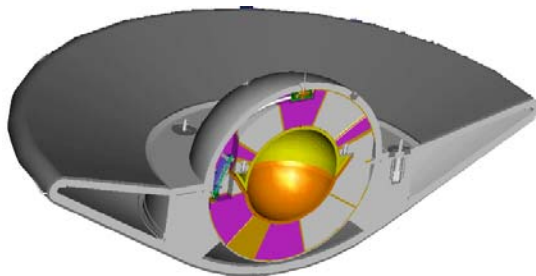

Figure 1: EEV 3D Model

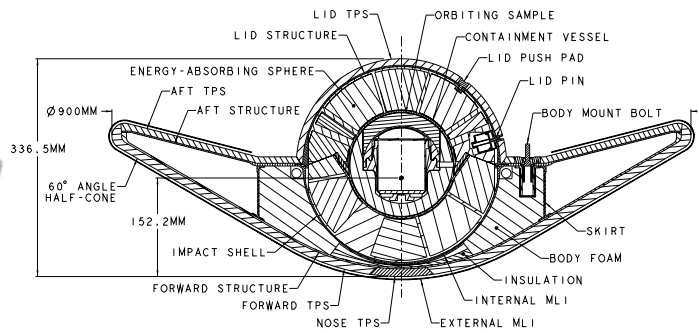

Figure 2: EEV Cross Section

The extremely high reliability requirement, combined with data on the low-but-finite failure rates of space flight hardware, led to the elimination of active flight systems from the EEV. There is no on-board attitude control system; the vehicle is released by the parent spacecraft on a ballistic, free-fall trajectory, and is spin-stabilized to maintain the proper orientation. The EEV was specifically designed such that its aerodynamics would serve as a passive backup to ensure proper orientation during reentry. Preliminary simulations show that even if a failure of the spacecraft's release system spin-stabilizes the EEV at 180° angle of attack (i.e. fully backwards), the vehicle will re-orient to nose-forward in the hypersonic flow regime before the entry heat pulse. There is likewise no parachute on the EEV. Instead, the vehicle is designed for a terminal velocity landing of 41m/s onto soft terrain, as shown in Figures 3 and 4. Ground tests at potential landing sites indicate that the nominal soft terrain at landing sites similar to UTTR will cushion landing loads below the 2500G level desired for preservation of the scientific value of the samples.



Figure 3: UTTR Terrain



Figure 4: Full-size EEV Drop Model at UTTR

Session IX: Sample Return Challenges

In the event of a hard-surface landing, the deceleration load is limited by the spherical impact energy absorber that surrounds the sample container and containment vessel. The energy absorber is a cellular structure, with resin-impregnated Kevlar and carbon walls braced by carbon foam to prevent buckling; the walls deform and tear to absorb energy as the sphere crushes. Full-velocity tests of the impact energy absorber onto concrete at Langley's Landing and Impact Research Facility (LandIR), shown in Figure 5, have shown that the energy absorbing sphere will keep landing loads below the 3500G design value for sample containment. Non-linear finite element impact analysis models and simulations (Figure 6) of the energy absorber have been developed, validated against the LandIR drop tests, and used to assess landing performance for a range of ground impact conditions. Through this analysis it has been demonstrated that the spherical energy absorber accommodates angled impacts arising from vehicle dynamics during terminal descent, ground slope irregularities and lateral winds.



Figure 5: Impact test at Langley

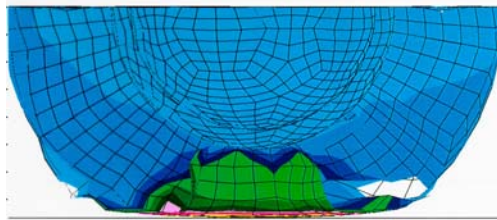

Figure 6: Impact absorber model

The EEV structure maintains the shape of the vehicle against the 130G entry deceleration load. The 2003/05 design used a 2D carbon-carbon structure, which provided high-temperature capability that reduced the risk of a structural failure in the event of the TPS bond line overheating. However, difficulties in developing analysis methods for progressive crack growth in the carbon-carbon proved challenging enough that a titanium structure is being considered. PRA evaluation indicated that the titanium structure is a viable design, with the elimination of analysis uncertainties balancing the loss of the high-temperature capabilities of carbon-carbon.

The EEV thermal protection system (TPS) protects the vehicle and the sample container from reentry heating. The reliability requirement drove the selection of the forward TPS to fully dense carbon-phenolic (FDCP) based on its extensive flight heritage. FDCP has seen thousands of tests and hundreds of flights in uses ranging from missile re-entry heat shields to solid rocket nozzle throats to the primary heat shields for the Galileo and Pioneer Venus entry probes. Two distinct types of FDCP TPS are required: tape-wrapped FDCP for most of the EEV forebody, and chopped-molded FDCP at the forward stagnation point where the spherical nose geometry prevents use of the tape-wrapped material. Sample coupons of both types of FDCP have passed arc-jet tests for the predicted peak heat flux and full heat load, as shown in Figures 7 and 8. However, additional development is still required as there are gaps in the information on the heritage fabrication techniques for the chopped-molded FDCP.

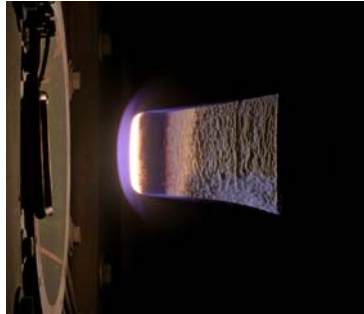

Figure 7: Carbon-phenolic in arc-jet



Figure 8: Carbon-phenolic after testing

TPS sizing analyses indicate a required FDCP thickness of 12mm. Modern low density TPS materials could potentially produce a lower mass heat shield than the FDCP, but the low density TPS materials may not have enough heritage to meet the sample containment reliability requirements. The aft TPS material is expected to see only a few percent of the forward heat flux, but will still need high reliability to ensure sample containment. Selection of the aft TPS still awaits a capability and heritage survey of available materials; existing EEV mass estimates use 10mm of SLA-561V as the aft TPS.

A micrometeoroid shield is needed to protect the EEV TPS from damage during the round trip to Mars, as ground test facilities cannot duplicate the combined reentry air flows and heating conditions thoroughly enough to reliably prove that a damaged TPS will survive Earth entry. However, JPL studies indicate that micrometeoroid shielding capable of fully protecting the EEV for the entire Mars round trip, as shown in Figure 9, would be prohibitively large and massive⁴. An alternative approach was developed, where a smaller shield protects the EEV to a level deemed acceptable for mission success, and sensors detect any penetration of the shield, which would trigger a mission abort. This smaller shield must still provide a high level of micrometeoroid and orbital debris protection for the EEV between the time that the EEV is released by the parent spacecraft to when atmospheric entry begins, when mission abort will no longer be possible. In addition, to avoid interfering with proper functioning of the TPS the micrometeoroid shield must separate cleanly from the EEV before the entry heat pulse; one notional approach calls for stitching wedge-shaped shield segments to each other with low-melting-point thread, so that the shield comes off early in entry before TPS ablation begins.

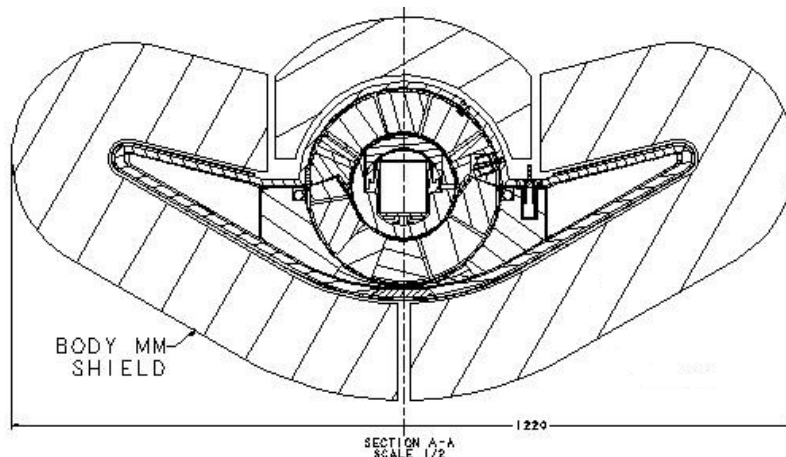

Figure 9: Large micrometeoroid shield

After landing, thermal energy from the hot TPS transfers to the surrounding environment and also soaks slowly into the interior structure. The energy absorbing sphere, even if partially crushed by a hard landing, insulates the sample container from the hot TPS. Container temperatures are predicted to proceed smoothly from pre-entry cold soak conditions to the ambient temperature of the landing site. No combination of thermal assumptions, such as lack of contact between the hot TPS and the ground, was found that would raise the sample container temperature above ambient⁵.

Remaining Development Tasks

Maturing the MSR EEV design to a flight-ready condition will require work in multiple areas, all of which interact due to the highly integrated nature of the EEV design. These areas include the impact energy absorber, aft body geometry, aerodynamic stability, TPS, micrometeoroid shield, EEV structural and mechanical design, and planning for the EEV system validation flight test. Requirements for these subsystems must be updated to reflect the parameters of the 2018 mission, and PRA techniques must be used to guide the design development.

The impact energy absorber's basic configuration and technology are relatively mature, but the design must be updated to reflect the new sample container size & mass for the 2018 MSR mission, and the overall EEV must then be updated to reflect the growth of the impact energy absorber. The impact energy absorber design must also be changed to use flight-qualified materials, which was not a requirement for the earlier ground-based development tests. Additional changes are expected to accommodate maturing interfaces with the sample container, containment vessel, and EEV hardware such as the lid latches.

While the forward surface of the EEV exceeds 2000°C during entry, the aft surface currently stays below the 500°C sterilization temperature. Previous risk mitigation activities identified several potential geometry changes, shown in Figure 10, that could produce enough additional aft heating to sterilize any Mars dust clinging to the outside of the EEV. These geometry options need detailed aerothermal evaluation; this will require selection of a baseline aft TPS, which must be preceded by a capability and heritage survey of TPS materials designed for the anticipated aft body environment.

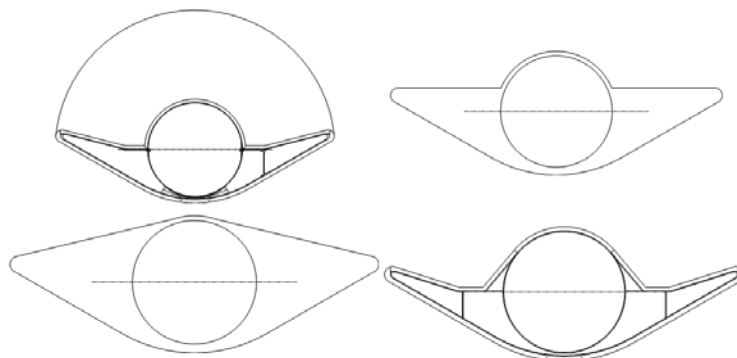

Figure 10: Example aft body alternatives

Session IX: Sample Return Challenges

Since the EEV geometry affects the vehicle aerodynamics and stability, changes in aft geometry must be integrated with an updated aerodynamic model and reentry trajectory simulation. Vehicle aerodynamic analyses must be updated to verify the EEV's hypersonic re-orientation capability and its passive aerodynamic stability throughout the entry/descent flight regime. Additional wind tunnel / drop testing will be used to demonstrate vehicle stability and derive the necessary flight aerodynamic database.

In addition to selection of an aft TPS, further TPS development and testing is needed to verify that the heritage processing techniques of the carbon-phenolic heat shield can be fully recreated and used to produce flight-qualified TPS hardware that will meet the PRA reliability requirements. Joint designs between different segments of the EEV TPS, as well as TPS penetrations for cabling to control actuation of the lid latches and sealing of the flexible containment vessel, must also be matured to flight level and then qualified through environmental testing in arc-jet facilities. Trade studies of alternate TPS materials should be conducted to investigate potential mass benefits or simplified micrometeoroid shielding approaches.

Continued development of the micrometeoroid shielding is needed to mature the design to flight level, and demonstrate that the design can protect the EEV without interfering with the performance of the vehicle TPS. Mission trade studies need to be conducted to investigate whether the period between EEV release from the spacecraft and Earth entry can be shortened sufficiently to remove the need for micrometeoroid shielding during this portion of the mission, which would simplify the development of the shield by removing the need to passively shed the micrometeoroid shield during reentry. Trade studies also need to be conducted on alternate shielding approaches.

The overall EEV structural and mechanical design needs to be matured to a flight level through detailed design of the structural components and lid latches, and integration of these components with the other EEV hardware as well as the interfaces to the parent spacecraft. The independent components of the system must be shown to function together in the context of the 10^{-6} sample containment reliability requirement. For example, dust sterilization, aft body TPS performance, the lid mechanism and latching configuration, containment vessel configuration, and aerodynamic stability all have common factors related to the EEV aft body geometry, and the EEV technology as a whole can only be advanced to flight readiness when these interfacing subsystems are demonstrated as a system. This development activity will include the fabrication, assembly, and ground testing of EEV engineering development units to illustrate the system level integration and functionality of the EEV design.

Planning for the EEV system validation flight test must continue as well. This sub-orbital test of a flight-like EEV in relevant reentry conditions is expected to occur in 2015, just after the MSR Preliminary Design Review, and will validate analytical models and tools used in the PRA reliability estimates. Updates to the validation test plan will be required based on the changes to EEV system requirements and entry conditions for the 2018 mission.

Conclusion

The design of the Earth Entry Vehicle for a 2018/20 Mars Sample Return mission is expected to be similar to the EEV concept that was baselined for the earlier planned 2003/05 MSR mission. The longevity of this EEV design speaks to the robustness of the EEV concept, where aerodynamic performance, heritage materials, and passive impact attenuation form the basis of meeting the stringent 10^{-6} sample containment requirement. The EEV design has been matured by the technology development activities through 2004, but the future technology advancements and risk reduction activities presented here, culminating with a full-scale EEV system validation flight test, are necessary to prepare the EEV for flight readiness in support of a 2018/20 MSR mission.

References

1. Mitcheltree, R.; Hughes, S.; Dillman, R.; and Teter, J.; “An Earth Entry Vehicle for Returning Samples from Mars”, 2nd International Symposium on Atmospheric Reentry Vehicles and Systems, AAAF paper ARVS-102, March 2001.
2. Mattingly, R; Hayati, S; and Udomkesmalee, G.; “Technology Development Plans for the Mars Sample Return Mission”, IEEE AC paper #1518, January 2005.
3. Dillman, R.; Laub, B.; Kellas, S; and Schoenenberger, M.; “Development and Test Plans for the MSR EEV”, 2nd International Planetary Probe Workshop, August 2004.
4. Gershman, R.; Adams, M.; Mattingly, R.; Rohatgi, N.; Corliss, J.; Dillman, R.; Fragola, J.; Minarick, J.; “Planetary Protection for Mars Sample Return”, COSPAR PTP1-0011-02, 2002.
5. Amundsen, R.; Dec, J.; and Lindell, M.; “Thermal Analysis Methods for an Earth Entry Vehicle”, 11th Thermal and Fluids Analysis Workshop, August 2000.