

THE VALUE OF PERFORMANCE.

NORTHROP GRUMMAN



MK242

25mm BUSHMASTER® CHAIN GUN®

Northrop Grumman's Medium caliber cannons boast unrivaled reliability and effectiveness. When paired with our exceptional training services, certified accessories, and OEM warranties, Northrop Grumman delivers best-in-class value and a guarantee of optimal performance. No matter what your mission critical objectives are; combat, peacekeeping, or training; we offer the necessary services to maintain your weapons systems at a fully mission capable rating and the ability to consistently sustain and optimize your fleet.

Guns Segment Market

The Gun Systems Market Segment exists to meet the ever changing demands of the warfighter through innovation in technology, program execution, lifecycle cost, and product delivery. The guns team is committed to becoming the undeniable global leader in medium caliber gun systems support, an agile competitor and respected worldwide as a preeminently responsive partner.

Facts At A Glance

Demonstrated reliability, accuracy and safe operation under all firing conditions

Primary armament on the U.S. Army's and allied Bradley Fighting Vehicle as well as the Marine Corp's Light Armored Vehicle

Adapts to many naval applications

Fires all NATO standard 25mm x 137mm ammunition

Dual feed system

Electronic and mechanical round counting capability

Minimal turret intrusion

northropgrumman.com

©2018 Northrop Grumman Corporation.
All Rights Reserved.

Automatic Cannon

The 25mm Bushmaster® automatic cannon is a battle-proven performer featuring dual feed Chain Gun technology. Northrop Grumman Medium Caliber Systems has delivered more than 10,500 M242s to the U.S. Army and forces around the world. Its design simplicity, external power, round control, ease of maintenance and constant velocity ammunition feed make it the most reliable automatic cannon on the modern battlefield.

Highly Reliable, Ease of Integration

Chain Gun design is product differentiation

Ease of integration along multiple variants:

High Reliability, Low Life Cycle Cost

Dual Feed linked system

Higher rate of fire available

Global Adoption

Installed base: 11,000 world-wide

Demonstrated accuracy and performance

- Combat Proven System w/multiple countries
- Multiple Operations (Desert Storm, Enduring Freedom and Iraqi Freedom)

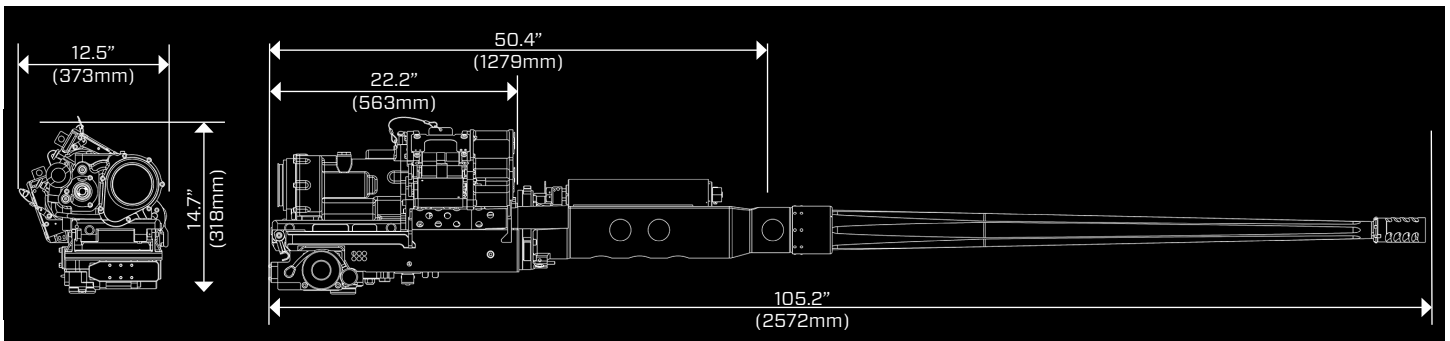

Characteristics

Recoil

Imperial

Metric

6,000 lb 7,500 lb
9,000 lb 12,000 lb

26,689 N 33,361 N
40,032 N 53,379 N

Weight*

Receiver

97 lb

44 kg

Feeder

58.5 lb

26.5 kg

Barrel

107 lb

48.5 kg

Total

262.5 lb

119.0 kg

Rate of Fire

Cyclic, Single Shot, Burst, and Full Automatic
@ 200 SPM.

Power Requirement

24VDC

Clearing Method

Cook off safe, open bolt

Safety

Absolute-hangfire protection

Case Ejection

Forward

northropgrumman.com

©2018 Northrop Grumman Corporation.
All Rights Reserved.

THE VALUE OF PERFORMANCE.

NORTHROP GRUMMAN