

# **SECTION 9**

## **FREIGHT VEHICLE COUPLERS AND DRAFT GEAR**



## TABLE OF CONTENTS

Section	Description	Page No.
9.1	<b>SCOPE</b> .....	9-1
9.2	<b>COUPLERS</b> .....	9-1
9.2.2	Types.....	9-1
9.3	<b>COUPLER LENGTHS</b> .....	9-2
9.4	<b>UNCOUPLING OPERATION</b> .....	9-2
9.5	<b>OFFSET SHANKS</b> .....	9-2
9.6	<b>YOKE</b> .....	9-2
9.7	<b>YOKE PIN</b> .....	9-2
9.8	<b>DRAFT GEAR FOLLOWER</b> .....	9-3
9.9	<b>RIGID DRAWBARS</b> .....	9-3
9.10	<b>SLACKLESS DRAWBARS</b> .....	9-3
9.11	<b>ARTICULATED CONNECTOR</b> .....	9-4
9.12	<b>DRAFT GEAR</b> .....	9-4
9.13	<b>CUSHIONING DEVICES</b> .....	9-4
Diagram 9-1	Standard Coupler.....	9-5
Diagram 9-2	Interlocking Coupler.....	9-6
Diagram 9-3	Standard Yoke.....	9-7
Diagram 9-4	Yoke Pin.....	9-8
Diagram 9-5	Standard Follower.....	9-9
Diagram 9-6	Interlocking Follower.....	9-10

## 9.1 SCOPE

- 9.1.1 This Section describes the minimum requirements for drawgear components for new freight vehicles including those which have been substantially modified or reconstructed.
- 9.1.2 It includes requirements for couplers, yokes, pins, draft gear, followers, draw bars, articulated connectors and cushioning devices.
- 9.1.3 Except where stipulated otherwise, all components described herein shall comply with the relevant requirements of Sections B and BII of the AAR Manual of Standards and Recommended Practices.

## 9.2 COUPLERS

- 9.2.1.1 The coupler shall be in accordance with Diagrams 9-1 or 9-2 as specified hereafter.
- 9.2.1.2 The coupler shown on Diagram 9-1 is based on the AAR E/F Coupler with the shank, butt and pin hole modified as shown for Australian operations. Relevant AAR specifications are:
- (a) S-108: Standard 'E/F' Coupler
  - (b) S-109: Standard 'E/F' Coupler
  - (c) S-155: Standard 'E' Coupler, Double Shelf
  - (d) S-165: Standard 'E' Coupler, Bottom Shelf
  - (e) S-170: Standard 'E' Coupler, Bottom Shelf
- 9.2.1.3 The coupler shown on Diagram 9-2 is identical to the AAR 'F' Interlocking Coupler except for the shank length. Relevant AAR Specifications are:
- (a) S-110: Standard 'F' Coupler (29.25")
  - (b) S-112: Standard 'F' Coupler (43")
  - (c) S-114: Standard 'F' Coupler (60")
- 9.2.1.4 Couplers to Diagram 9-1 shall have the No.10A contour to AAR Standard S-106.
- Couplers to Diagram 9-2 shall have the 'F' Interlocking contour to AAR Standard S-117.
- 9.2.1.5 Coupler material shall be cast steel to:
- AAR Specification M-201 Grade E - with the impact test at 0<sup>o</sup>c acceptable  
or alternatively  
AS 2074 Grade L6B2 - with Charpy impact test at 0<sup>o</sup>C to AS 1544, Part 2, 3 tests required, average energy 27J minimum, and no individual test less than 20J

### 9.2.2 TYPES

New or substantially modified vehicles shall be fitted only with the following types of couplers.

- 9.2.2.1 All vehicles, except tank cars for the conveyance of dangerous goods in bulk, shall conform to the requirements of Diagram 9-1 with a bottom shelf or Diagram 9-2 with bottom shelf if interlocking couplers are required.
- 9.2.2.2 Tank cars for the conveyance of dangerous goods in bulk shall be fitted with couplers conforming to Diagram 9-1 with top and bottom shelves (double shelf type).
- 9.2.2.3 The use of interlocking couplers to Diagram 9-2 requires a flexible coupler carrier to be fitted to the vehicle to accommodate relative vertical displacement of the coupled vehicles.
- 9.2.2.4 Special purpose couplers for rotary-dump operations etc may be fitted where required. These couplers shall comply with all relevant aspects of this section and AAR requirements, with the impact and Charpy tests as specified in Clause 9.2.1.5.

### **9.3 COUPLER LENGTHS**

- 9.3.1 The length of the coupler shall be in accordance with the dimensions given on Diagrams 9-1 and 9-2, and selected to ensure compliance with the operational parameters of the L/V ratio and curve negotiability specified in Section 8 of this Manual.

### **9.4 UNCOUPLING OPERATION**

- 9.4.1 Top operated couplers, straight lift, shall be fitted to all vehicles except where the protrusion of the uncoupling mechanism above the coupler may:
- (a) Render the mechanism prone to damage or fouling, eg flat cars, container cars etc  
OR
  - (b) Interfere with or hinder normal loading, unloading or operation of the vehicle, eg TOFC cars, motor car carriers, livestock cars with end doors, etc. In these circumstances, couplers with rotary lift bottom operation shall be used.

### **9.5 OFFSET SHANKS**

- 9.5.1 The minimum deck/floor heights specified in other Sections of this Manual provide for the use of straight shank couplers. Couplers with offset shanks are not required for vehicles which comply with these requirements.
- 9.5.2 Special purpose vehicles, for which a deck height lower than that specified is desired, may be fitted with couplers having a vertical offset between coupler head and shank of 35 mm.
- 9.5.3 The use of offset couplers is undesirable and vehicle design shall incorporate, wherever possible, the structural alternatives which permit straight shank couplers to be installed at the standard coupler height.

### **9.6 YOKE**

- 9.6.1 The yoke for use with couplers to Diagrams 9-1 and 9-2 shall conform to Diagram 9-3. It shall comply with AAR Standard S-149, except that the pin hole shall be bushed and a manganese steel wear plate fitted as shown. The material shall be as specified in Clause 9.2.1.5.
- 9.6.2 Yokes for use with special purpose couplers shall also comply with 9.6.1 where appropriate, modified as required to suit the coupler design.
- 9.6.3 Manufacture and acceptance shall be generally in accordance with AAR Specifications S-118 and M-211.

### **9.7 YOKE PIN**

- 9.7.1 The yoke pin for use with couplers to Diagrams 9-1 and 9-2 shall be of 89 mm nominal diameter as shown on Diagram 9-4.
- 9.7.2 The yoke pin for use with special-purpose couplers shall have a load capacity, as installed, at least equivalent to that of the pin specified in 9.7.1.

9.7.3 Pins shall comply with AAR Specification M-118. Alternative materials to that specified are:

- (a) AS 2506/4140T
- (b) AS 2506/X9931T

## **9.8 DRAFT GEAR FOLLOWER**

9.8.1 The follower for use with couplers to Diagram 9-1 shall conform to the requirements of Diagram 9-5.

9.8.2 The follower for use with couplers to Diagram 9-2 shall conform to AAR Standard S-119, catalogue number Y46AE, as indicated on Diagram 9-6.

9.8.3 Followers for use with special purpose couplers shall be designed and manufactured to suit the installation.

9.8.4 All followers shall be manufactured from cast steel with the material as specified in Clause 9.2.1.5.

## **9.9 RIGID DRAWBARS**

9.9.1 Rigid drawbars are permitted to permanently connect two or more vehicles where the facility for uncoupling in service is not required.

9.9.2 The rigid drawbar may be connected to a standard yoke and draft gear in each vehicle with standard pins, or to end-of-car cushioning devices.

9.9.3 The drawbar ends and shank dimensions shall be identical to those of the interlocking coupler, Diagram 9-2. The length of the drawbar shall be selected to comply with the parameters of the L/V ratio and curve negotiability specified in Section 8 of this Manual, and to provide the required operational clearance between adjacent vehicles.

9.9.4 The drawbars shall be manufactured from cast steel with the material as specified in Clause 9.2.1.5. or be fabricated from steel.

9.9.5 The drawbar and components shall be designed to withstand longitudinal buff and draft forces equivalent to those of the couplers, Clause 9.2.

## **9.10 SLACKLESS DRAWBARS**

9.10.1 Slackless drawbars are permitted to permanently connect two or more vehicles where the facility for uncoupling in service is not required and where there is a need to minimise train slack.

9.10.2 The slackless drawbar shall connect to each vehicle with an assembly incorporating components for load transfer and self adjustment of wear induced slack, without draft gear.

9.10.3 The drawbar shall be designed to permit movement in the vertical and lateral planes.

9.10.4 The length of the drawbar shall be selected to comply with the parameters of L/V ratio and curve negotiability specified in Section 8 of this Manual, and to provide the required operational clearance between adjacent vehicles.

9.10.5 The slackless drawbars shall be manufactured from cast steel with the material as specified in Clause 9.2.1.5, or be fabricated from steel.

9.10.6 The slackless drawbar and components shall be designed to withstand longitudinal buff and draft forces equivalent to those of the couplers, Clause 9.2.

## **9.11 ARTICULATED CONNECTOR**

- 9.11.1 Articulated connectors are used to permanently couple adjacent units sharing a common bogie and forming part of an articulated vehicle.
- 9.11.2 The connectors shall consist of inter-connecting male and female components, each permanently attached to the end structure of the vehicle units. The two components shall be permanently coupled at assembly by means of a vertical pin with positive retention.
- 9.11.3 The connector shall be designed to permit rotation in the longitudinal, vertical and lateral planes, with sufficient internal clearance to permit the vehicle to be lifted clear of the bogie.
- 9.11.4 Longitudinal buff forces shall be transmitted by direct contact between the mating components; draft forces shall be transmitted through the connecting pins.
- 9.11.5 The connector assembly shall incorporate components for load transfer and self-adjustment of wear induced slack.
- 9.11.6 The female component shall incorporate a spigot, equivalent to a body centre plate, to mate with the bogie centre plate and include provision for a bogie centre pin.
- 9.11.7 The minimum capacity for angular rotation when installed shall be:
- (a) Vertical plane (concave and convex) :  $7^{\circ}30'$   
(for undulations and lifting)
  - (b) Horizontal plane :  $\pm 18^{\circ}$   
(for curving)
  - (c) Lateral roll :  $\pm 5^{\circ}$   
(for twist)
- 9.11.8 The connector and components shall be designed to withstand longitudinal buff and draft forces equivalent to those of the couplers, Clause 9.2.

## **9.12 DRAFT GEAR**

- 9.12.1 All draft gear shall comply with the requirements of AAR Specifications M-901E and M-901F, M-901G or M-901H.
- 9.12.2 Draft gears purchased as second-hand or reconditioned shall be certified as complying with the requirements of AAR Specification M-901B.

## **9.13 CUSHIONING DEVICES**

- 9.13.1 Cushioning devices provide energy absorption over a greater travel than that provided by standard draft gear, and may be installed at the centre of the car or at the end of the car.
- 9.13.2 New cushioning devices shall comply with the requirements of AAR Specification M-921A and have AAR approval.
- 9.13.3 Devices purchased as reconditioned shall be certified as complying with the requirements of AAR Specification M-921C.

DIAGRAM 9-1

STANDARD COUPLER

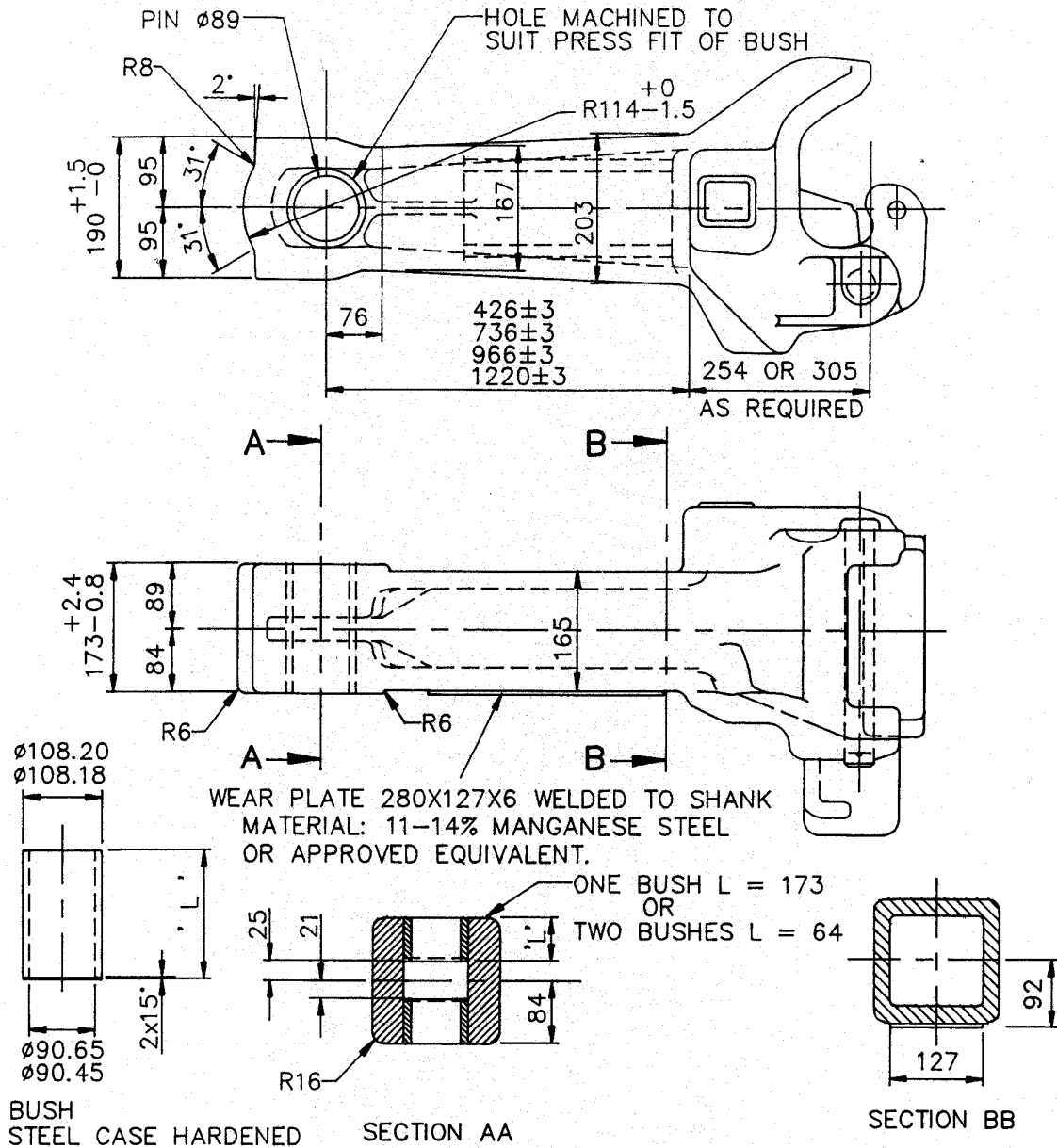

COUPLER MATERIAL:

CAST STEEL AAR M201 GRADE E WITH IMPACT TEST AT 0°C ACCEPTABLE OR ALTERNATIVELY  
 CAST STEEL AS 2074 GRADE L6B2 WITH CHARPY IMPACT TEST AT 0°C TO AS 1544 PART 2 3 TESTS REQUIRED AVERAGE ENERGY 27 J MIN  
 NO INDIVIDUAL TEST < 20 J.

FOR DETAILS NOT SPECIFIED REFER TO :

- AAR STANDARD E/F COUPLERS S-108 S-109
- AAR STANDARD BOTTOM SHELF E COUPLERS S-165 S-170
- AAR STANDARD E COUPLERS WITH TOP AND BOTTOM SHELVES S-155



DIAGRAM 9-2

INTERLOCKING COUPLER

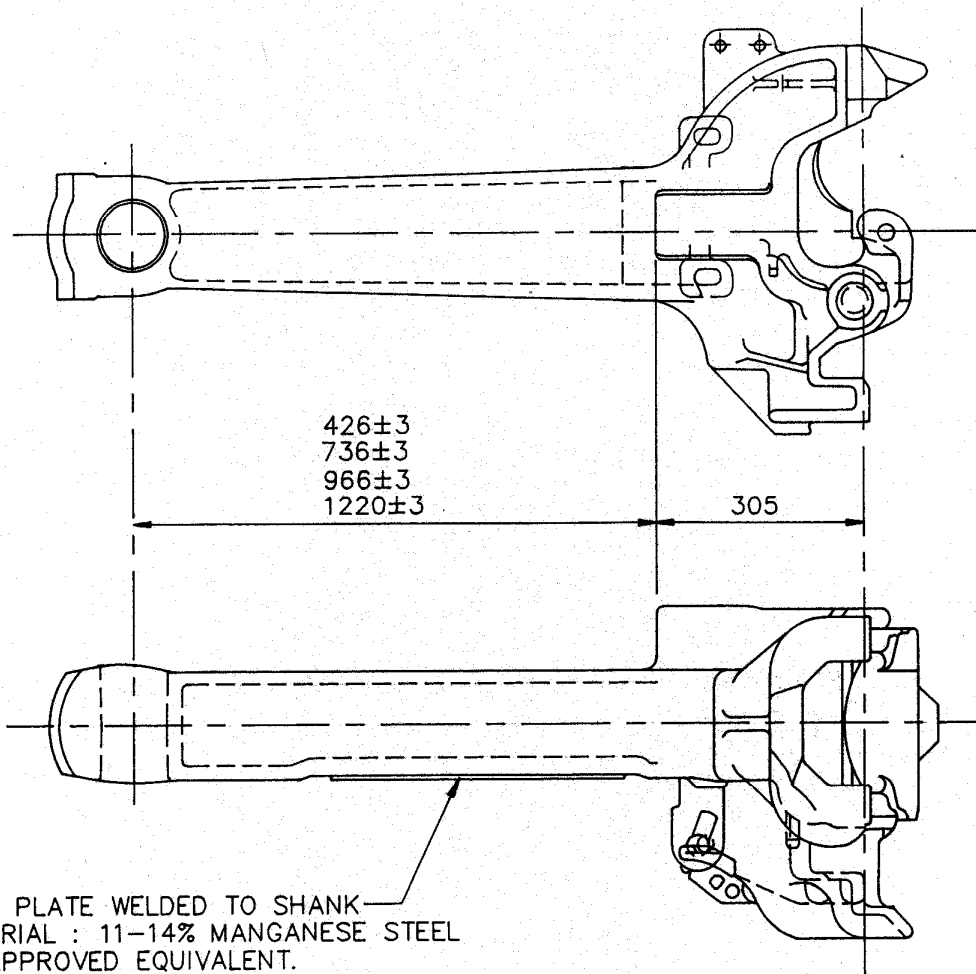

COUPLER MATERIAL:

CAST STEEL AAR M201 GRADE E - WITH IMPACT TEST AT 0°C ACCEPTABLE  
OR ALTERNATIVELY

CAST STEEL AS 2074 GRADE L6B2 - WITH CHARPY IMPACT TEST  
AT 0°C TO AS 1544 PART 2  
3 TESTS REQUIRED

AVERAGE ENERGY 27 J MIN  
NO INDIVIDUAL TEST < 20 J

FOR DETAILS NOT SPECIFIED HEREON REFER TO :  
AAR STANDARD F COUPLERS S-110 S-112 S-114

**DIAGRAM 9-3**  
**STANDARD YOKE**

**PAGE NOT IN ORIGINAL  
PRINTED DOCUMENT**

DIAGRAM 9-4

YOKE PIN

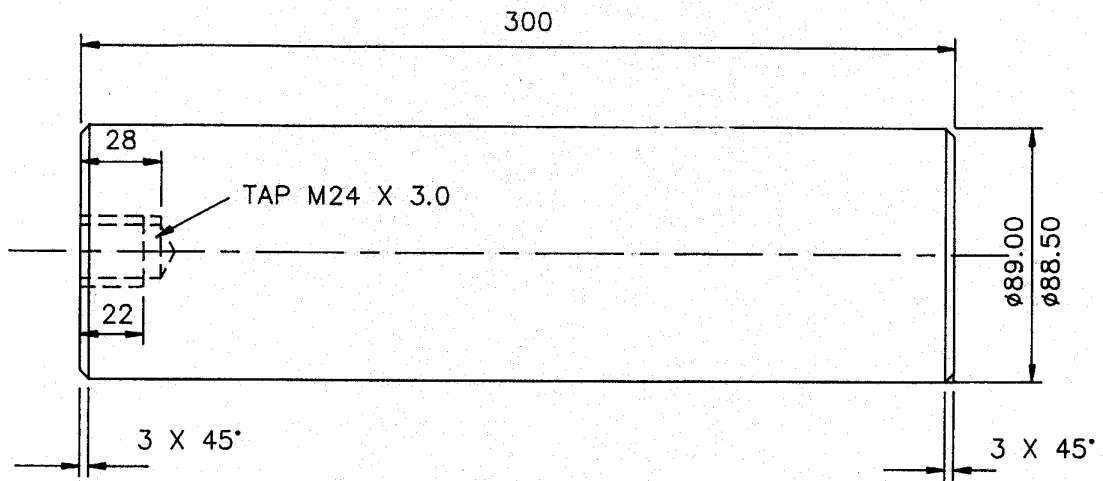

YOKE PIN MATERIAL : AAR M118  
OR  
AS 2506/4140T  
OR  
AS 2506/X9931T

DIAGRAM 9-5  
STANDARD FOLLOWER

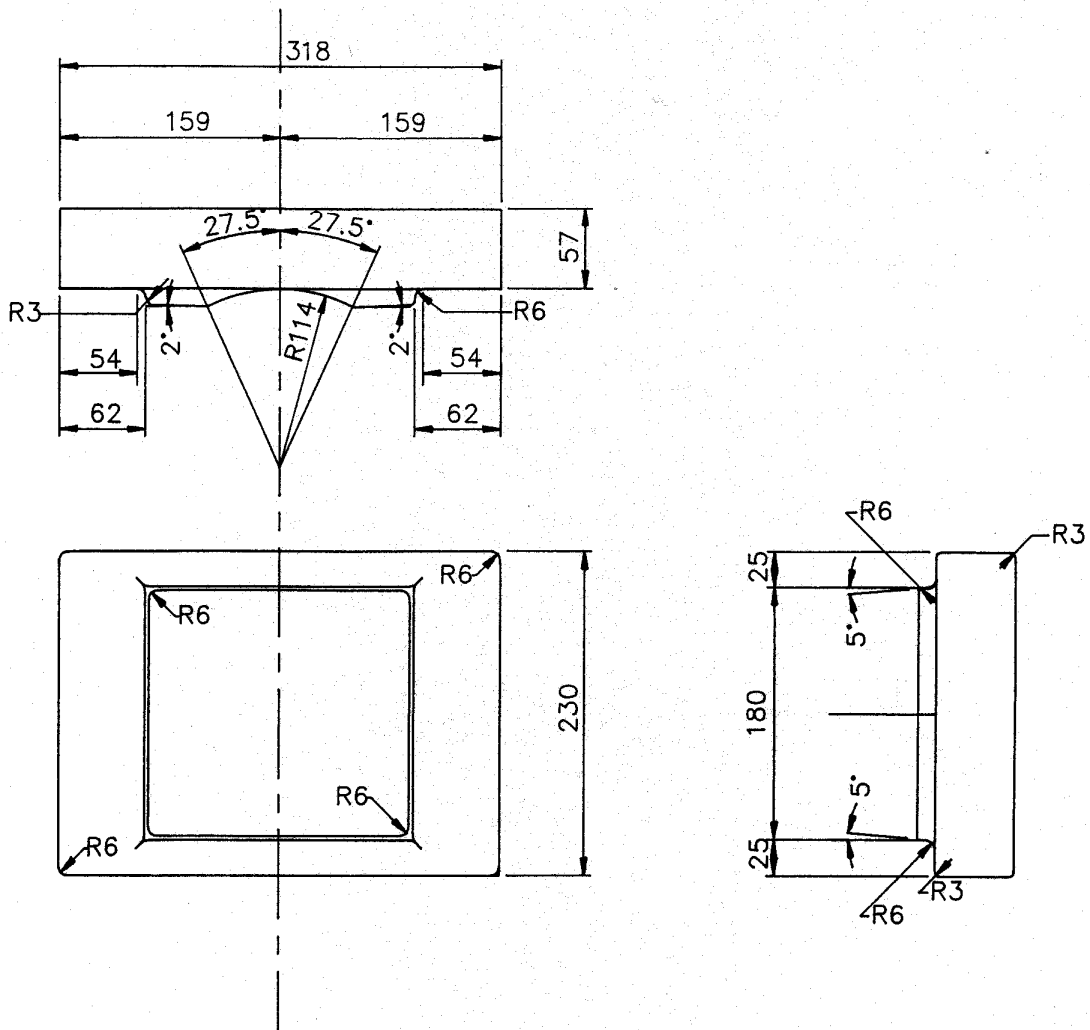

FOLLOWER MATERIAL:

CAST STEEL AAR M201 GRADE E - WITH IMPACT TEST AT 0°C ACCEPTABLE  
OR ALTERNATIVELY

CAST STEEL AS 2074 GRADE L6B2 - WITH CHARPY IMPACT TEST  
AT 0°C TO AS 1544 PART 2  
3 TESTS REQUIRED  
AVERAGE ENERGY 27 J MIN  
NO INDIVIDUAL TEST < 20 J

DIAGRAM 9-6

INTERLOCKING FOLLOWER

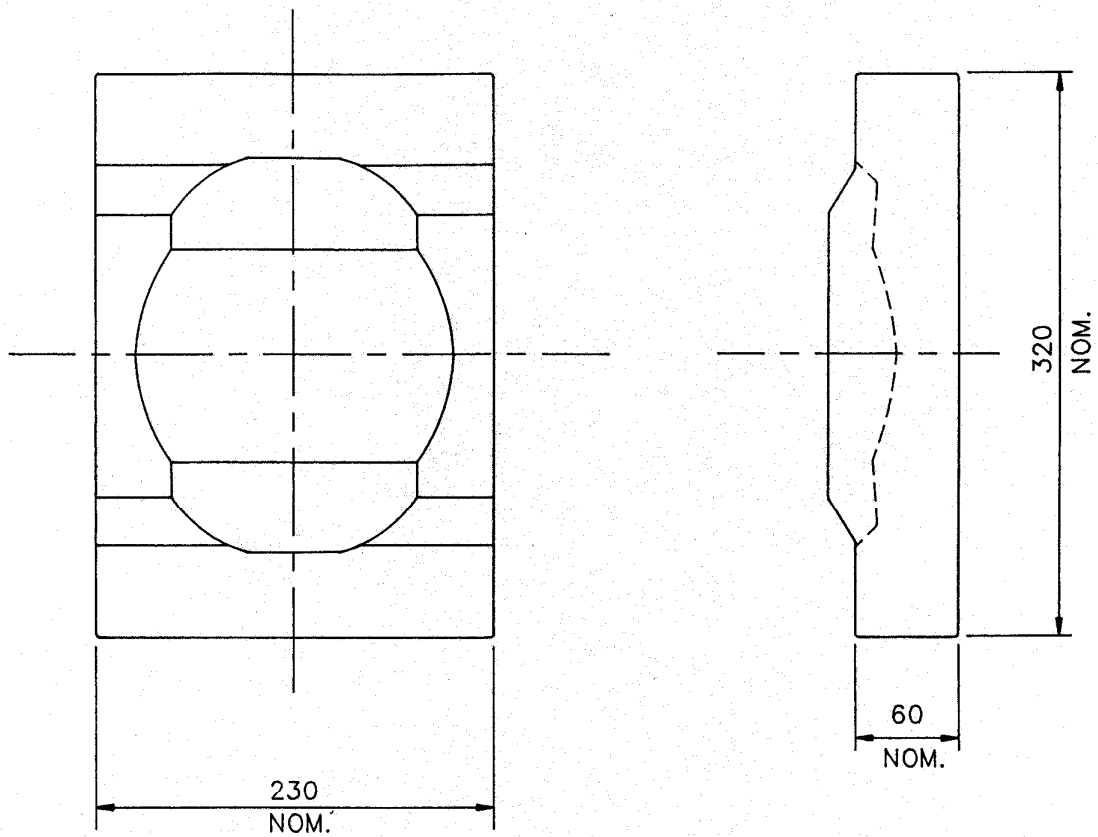

DETAILS AS PER AAR FOLLOWER

CATALOGUE NO. Y46AE