



ANSI/TIA-968-A-2002
Approved: October 29, 2002

TIA STANDARD

Telecommunications

Telephone Terminal Equipment

Technical Requirements for Connection of Terminal Equipment to the Telephone Network

TIA-968-A

(Upgrade and Revision of TIA/EIA/IS-968)

OCTOBER 2002

TELECOMMUNICATIONS INDUSTRY ASSOCIATION



Representing the telecommunications industry in
association with the Electronic Industries Alliance



Adopted by ACTA
January 15, 2003

PREFACE

This document, TIA-968-A, *Telecommunications – Telephone Terminal Equipment – Technical Requirements for Connection of Terminal Equipment to the Telephone Network*, has been established pursuant to the Federal Communication Commission's ("FCC") Report and Order in the 2000 Biennial Review of Part 68 of the Commission's Rules and Regulations, CC Docket No. 99-216, FCC 00-400, adopted November 9, 2000 and released December 21, 2000 ("Order" or "R&O"). The Order privatized the process by which technical criteria for the prevention of harm are established for customer premises or terminal equipment that may be sold for connection to the telephone network, and for the approval of such equipment to demonstrate compliance with the relevant technical criteria. The Order directed the industry to establish the Administrative Council on Terminal Attachments ("ACTA") as the balanced and open body that would assume the Commission's Part 68 role for those items privatized in the Order (Section 68.602). This document was created for submission to ACTA by the TIA Subcommittee TR-41.9, Technical Regulatory Considerations. It is intended to fulfill the FCC's requirement to establish technical criteria for Telephone Terminal Equipment labeling requirements for Part 68 of Title 47 of the Code of Federal Regulations.

Notice of Disclaimer and Limitation of Liability

THE INFORMATION PROVIDED IN THIS DOCUMENT IS PROVIDED "AS IS" AND "AS AVAILABLE." SUCH INFORMATION IS DIRECTED SOLELY TO PROFESSIONALS WHO HAVE THE APPROPRIATE DEGREE OF EXPERIENCE TO UNDERSTAND AND INTERPRET ITS CONTENTS, AND ANY AND ALL USE OF OR RELIANCE UPON THIS INFORMATION IS AT THE USER'S OWN DISCRETION AND AT ITS OWN RISK.

ALL WARRANTIES, EXPRESS OR IMPLIED, ARE DISCLAIMED, INCLUDING WITHOUT LIMITATION, ANY AND ALL WARRANTIES CONCERNING THE ACCURACY OF THE INFORMATION, ITS FITNESS OR APPROPRIATENESS FOR A PARTICULAR PURPOSE OR USE, ITS MERCHANTABILITY AND ITS NON-INFRINGEMENT OF ANY THIRD PARTY'S INTELLECTUAL PROPERTY RIGHTS. ACTA (TOGETHER WITH ITS MEMBERS, AFFILIATES AND SPONSORS, EXPRESSLY DISCLAIMS ANY AND ALL RESPONSIBILITIES FOR THE ACCURACY OF THE INFORMATION AND MAKES NO REPRESENTATIONS OR WARRANTIES REGARDING THE INFORMATION'S COMPLIANCE WITH ANY APPLICABLE STATUTE, RULE OR REGULATION.

ACTA, AND ITS MEMBERS, AFFILIATES AND SPONSORS, EXPRESSLY DISCLAIM, AND SHALL NOT BE LIABLE, FOR, ANY AND ALL DAMAGES, DIRECT OR INDIRECT, ARISING FROM OR RELATING TO ANY USE OF THE INFORMATION CONTAINED HEREIN, INCLUDING WITHOUT LIMITATION ANY AND ALL INDIRECT, SPECIAL, INCIDENTAL OR CONSEQUENTIAL DAMAGES (INCLUDING DAMAGES FOR LOSS OF BUSINESS, LOSS OF PROFITS, LITIGATION, OR THE LIKE), WHETHER BASED UPON BREACH OF CONTRACT, BREACH OF WARRANTY, TORT (INCLUDING NEGLIGENCE), PRODUCT LIABILITY OR OTHERWISE, EVEN IF ADVISED OF THE POSSIBILITY OF SUCH DAMAGES, EXCEPT FOR SUCH DAMAGES AS MAY RESULT DIRECTLY FROM ACTA'S INTENTIONALLY UNLAWFUL OR GROSSLY NEGLIGENT ACTS. THE FOREGOING NEGATION OF DAMAGES IS A FUNDAMENTAL ELEMENT OF THE USE OF THE INFORMATION AND DATA CONTAINED HEREIN, AND THIS INFORMATION WOULD NOT BE PUBLISHED BY ACTA WITHOUT SUCH LIMITATIONS.

NOTICE

TIA Engineering Standards and Publications are designed to serve the public interest through eliminating misunderstandings between manufacturers and purchasers, facilitating interchangeability and improvement of products, and assisting the purchaser in selecting and obtaining with minimum delay the proper product for their particular need. The existence of such Standards and Publications shall not in any respect preclude any member or non-member of TIA from manufacturing or selling products not conforming to such Standards and Publications. Neither shall the existence of such Standards and Publications preclude their voluntary use by Non-TIA members, either domestically or internationally.

Standards and Publications are adopted by TIA in accordance with the American National Standards Institute (ANSI) patent policy. By such action, TIA does not assume any liability to any patent owner, nor does it assume any obligation whatever to parties adopting the Standard or Publication.

This Standard does not purport to address all safety problems associated with its use or all applicable regulatory requirements. It is the responsibility of the user of this Standard to establish appropriate safety and health practices and to determine the applicability of regulatory limitations before its use.

(From Standards Proposal No. 3-0016-URV, formulated under the cognizance of the TIA TR-41.9 Subcommittee on Technical Regulatory Considerations.)

Published by
©TELECOMMUNICATIONS INDUSTRY ASSOCIATION 2002
Standards and Technology Department
2500 Wilson Boulevard
Arlington, VA 22201 U.S.A.

**PRICE: Please refer to current Catalog of
TIA TELECOMMUNICATIONS INDUSTRY ASSOCIATION STANDARDS
AND ENGINEERING PUBLICATIONS
or call Global Engineering Documents, USA and Canada
(1-800-854-7179) International (303-397-7956)
or search online at http://www.tiaonline.org/standards/search_n_order.cfm**

All rights reserved
Printed in U.S.A.

PLEASE!
DON'T VIOLATE
THE
LAW!

This document is copyrighted by the TIA and may not be reproduced without permission.

Organizations may obtain permission to reproduce a limited number of copies through entering into a license agreement. For information, contact:

Global Engineering Documents
15 Inverness Way East
Englewood, CO 80112-5704 U.S.A. or call
U.S.A. and Canada 1-800-854-7179, International (303) 397-7956

NOTICE OF DISCLAIMER AND LIMITATION OF LIABILITY

The document to which this Notice is affixed has been prepared by one or more Engineering Committees of the Telecommunications Industry Association (“TIA”). TIA is not the author of the document contents, but publishes and claims copyright to the document pursuant to licenses and permission granted by the authors of the contents.

TIA Engineering Committees are expected to conduct their affairs in accordance with the TIA Engineering Manual (“Manual”), the current and predecessor versions of which are available at http://www.tiaonline.org/standards/sfg/engineering_manual.cfm. TIA’s function is to administer the process, but not the content, of document preparation in accordance with the Manual and, when appropriate, the policies and procedures of the American National Standards Institute (“ANSI”).

THE USE OR PRACTICE OF CONTENTS OF THIS DOCUMENT MAY INVOLVE THE USE OF INTELLECTUAL PROPERTY RIGHTS (“IPR”), INCLUDING PENDING OR ISSUED PATENTS, OR COPYRIGHTS, OWNED BY ONE OR MORE PARTIES. TIA MAKES NO SEARCH OR INVESTIGATION FOR IPR. WHEN IPR CONSISTING OF PATENTS AND PUBLISHED PATENT APPLICATIONS ARE CLAIMED AND CALLED TO TIA’S ATTENTION, A STATEMENT FROM THE HOLDER THEREOF IS REQUESTED, ALL IN ACCORDANCE WITH THE MANUAL. TIA TAKES NO POSITION WITH REFERENCE TO, AND DISCLAIMS ANY OBLIGATION TO INVESTIGATE OR INQUIRE INTO, THE SCOPE OR VALIDITY OF ANY CLAIMS OF IPR.

ALL WARRANTIES, EXPRESS OR IMPLIED, ARE DISCLAIMED, INCLUDING WITHOUT LIMITATION, ANY AND ALL WARRANTIES CONCERNING THE ACCURACY OF THE CONTENTS, ITS FITNESS OR APPROPRIATENESS FOR A PARTICULAR PURPOSE OR USE, ITS MERCHANTABILITY AND ITS NON-INFRINGEMENT OF ANY THIRD PARTY’S INTELLECTUAL PROPERTY RIGHTS. TIA EXPRESSLY DISCLAIMS ANY AND ALL RESPONSIBILITIES FOR THE ACCURACY OF THE CONTENTS AND MAKES NO REPRESENTATIONS OR WARRANTIES REGARDING THE CONTENT’S COMPLIANCE WITH ANY APPLICABLE STATUTE, RULE OR REGULATION.

TIA SHALL NOT BE LIABLE FOR ANY AND ALL DAMAGES, DIRECT OR INDIRECT, ARISING FROM OR RELATING TO ANY USE OF THE CONTENTS CONTAINED HEREIN, INCLUDING WITHOUT LIMITATION ANY AND ALL INDIRECT, SPECIAL, INCIDENTAL OR CONSEQUENTIAL DAMAGES (INCLUDING DAMAGES FOR LOSS OF BUSINESS, LOSS OF PROFITS, LITIGATION, OR THE LIKE), WHETHER BASED UPON BREACH OF CONTRACT, BREACH OF WARRANTY, TORT (INCLUDING NEGLIGENCE), PRODUCT LIABILITY OR OTHERWISE, EVEN IF ADVISED OF THE POSSIBILITY OF SUCH DAMAGES. THE FOREGOING NEGATION OF DAMAGES IS A FUNDAMENTAL ELEMENT OF THE USE OF THE CONTENTS HEREOF, AND THESE CONTENTS WOULD NOT BE PUBLISHED BY TIA WITHOUT SUCH LIMITATIONS.

CONTENTS

1	GENERAL	1
1.1	SCOPE	1
1.2	NORMATIVE REFERENCES	2
1.3	DEFINITIONS	2
2	CONDITIONS ON USE OF TERMINAL EQUIPMENT	23
3	TERMINAL EQUIPMENT APPROVAL PROCEDURES	25
4	TECHNICAL REQUIREMENTS	27
4.1	LABELING	27
4.2	ENVIRONMENTAL SIMULATION	27
4.3	LEAKAGE CURRENT LIMITATIONS	32
4.4	HAZARDOUS VOLTAGE LIMITATIONS.....	34
4.5	SIGNAL POWER LIMITATIONS.....	42
4.6	TRANSVERSE BALANCE LIMITATIONS	68
4.7	ON-HOOK IMPEDANCE LIMITATIONS	80
4.8	BILLING PROTECTION	85
5	COMPLAINTS PROCEDURES	89
6	CONNECTORS	91
6.1	SPECIFICATIONS.....	91
6.2	CONFIGURATIONS	136
6.3	CONFIGURATIONS USED TO CONNECT MULTI-LINE COMMUNICATIONS SYSTEMS SUCH AS PRIVATE BRANCH EXCHANGE (PBX) AND KEY TELEPHONE SYSTEMS.....	136
	ANNEX A (NORMATIVE)	139
	ANNEX B (INFORMATIVE)	144
	ANNEX C (INFORMATIVE)	157
	ANNEX D (INFORMATIVE)	159
	ANNEX E (INFORMATIVE)	161

LIST OF FIGURES

FIGURE 1.1 2-WIRE LOOP SIMULATOR FOR LOOP START AND GROUND START CIRCUITS.....	10
FIGURE 1.2 LOOP SIMULATOR FOR REVERSE BATTERY CIRCUITS	11
FIGURE 1.3 LOOP SIMULATOR CIRCUIT FOR 4-WIRE LOOP START AND GROUND START	12
FIGURE 1.4 LOOP SIMULATOR CIRCUIT FOR 4-WIRE REVERSE BATTERY CIRCUITS	13
FIGURE 1.5 E&M TYPES I & II SIGNALING.....	14
FIGURE 1.6 E&M TYPES I & II SIGNALING.....	15
FIGURE 1.7 OFF PREMISES LOOP SIMULATOR.....	16
FIGURE 1.8 ALTERNATIVE TERMINATION	17
FIGURE 1.9 LOOP SIMULATOR CIRCUIT – VOICEBAND METALLIC CHANNELS.....	18
FIGURE 1.10 LADC IMPEDANCE SIMULATOR FOR METALLIC VOLTAGE TESTS	19
FIGURE 1.11 ZERO LEVEL DECODER TEST CONFIGURATION FOR SUB-RATE AND 1.544 MBPS DIGITAL CHANNELS	20
FIGURE 1.12 SIMULATOR CIRCUIT FOR PSDS TYPE II IN ANALOG MODE.....	21
FIGURE 4.1 SIMPLIFIED SURGE GENERATOR.....	31
FIGURE 4.2 OPEN CIRCUIT VOLTAGE WAVESHAVE, $T_R \times T_D$	31
FIGURE 4.3 SHORT CIRCUIT CURRENT WAVESHAVE, $T_R \times T_D$.....	31
FIGURE 4.4 RINGING VOLTAGE TRIP CRITERIA.....	40
FIGURE 4.5 RESISTIVE TERMINATIONS	55
FIGURE 4.6 ISOLATED PULSE TEMPLATE AND CORNER POINTS FOR ISDN PRA AND 1.544 MBPS EQUIPMENT	63
FIGURE 4.7 ILLUSTRATIVE TEST CIRCUIT FOR TRANSVERSE BALANCE (ANALOG)	74
FIGURE 4.8 ILLUSTRATIVE TEST CIRCUIT FOR TRANSVERSE BALANCE (DIGITAL)	75
FIGURE 4.9 OFF-HOOK TERMINATION OF MULTIPOINT EQUIPMENT FOR PORTS NOT UNDER TEST	76

FIGURE 4.10 REQUIRED TERMINATION FOR CONNECTIONS TO NON-APPROVED EQUIPMENT	77
FIGURE 4.11(A) TRANSVERSE BALANCE REQUIREMENTS FOR ISDN BRA, 1.544 MBPS (INCLUDING ISDN PRA) AND ADSL	78
FIGURE 4.11(B) TRANSVERSE BALANCE REQUIREMENTS FOR PSDS AND SUB-RATE SERVICES	78
FIGURE 4.12 REQUIRED TERMINATION FOR CONNECTIONS TO NON-APPROVED EQUIPMENT	79
FIGURE 6.1 VIEW OF MINIATURE 6-POSITION PLUG	92
FIGURE 6.2 6-POSITION PLUG MECHANICAL SPECIFICATION	93
FIGURE 6.3 6-POSITION PLUG MECHANICAL SPECIFICATION (CONTINUED).....	94
FIGURE 6.4 6-POSITION PLUG PLUG/JACK CONTACT SPECIFICATION	95
FIGURE 6.5 6-POSITION PLUG MINIMUM PLUG SIZE	97
FIGURE 6.6 6-POSITION PLUG MAXIMUM PLUG SIZE	98
FIGURE 6.7 6-POSITION JACK MECHANICAL SPECIFICATION	99
FIGURE 6.8 6-POSITION JACK MECHANICAL SPECIFICATIONS (CONTINUED).....	100
FIGURE 6.9 VIEW OF MINIATURE 8-POSITION PLUG, UNKEYED	103
FIGURE 6.10 8-POSITION UNKEYED PLUG MECHANICAL SPECIFICATION	104
FIGURE 6.11 8-POSITION UNKEYED PLUG, MECHANICAL SPECIFICATION (CONTINUED).....	105
FIGURE 6.12 8-POSITION UNKEYED PLUG, PLUG/JACK CONTACT SPECIFICATION	106
FIGURE 6.13 8-POSITION UNKEYED PLUG, MINIMUM PLUG SIZE	108
FIGURE 6.14 8-POSITION UNKEYED PLUG, MAXIMUM PLUG SIZE	109
FIGURE 6.15 8-POSITION SERIES JACK, CONTACT SPECIFICATION	110
FIGURE 6.16 8-POSITION SERIES JACK, MECHANICAL SPECIFICATION	111
FIGURE 6.17 8-POSITION SERIES JACK, MECHANICAL SPECIFICATION (CONTINUED).....	112
FIGURE 6.18 50-POSITION MINIATURE RIBBON PLUG	115
FIGURE 6.19 50-POSITION MINIATURE RIBBON PLUG SIZING GAUGE.....	116

FIGURE 6.20 50-POSITION MINIATURE RIBBON PLUG CONTINUITY GAUGE 117

FIGURE 6.21 50-POSITION MINIATURE RIBBON PLUG HOOD ENVELOPE..... 118

FIGURE 6.22 50-POSITION MINIATURE RIBBON JACK..... 120

FIGURE 6.23 50-POSITION MINIATURE RIBBON JACK SIZING GAUGE 121

FIGURE 6.24 50-POSITION MINIATURE RIBBON JACK CONTINUITY GAUGE 122

FIGURE 6.25 3-POSITION PLUG, PLUG ASSEMBLY 123

FIGURE 6.26 3-POSITION PLUG, DETAIL..... 124

FIGURE 6. 27 3-POSITION PLUG, DETAIL..... 125

FIGURE 6.28 VIEW OF MINIATURE 8-POSITION PLUG, KEYED..... 126

FIGURE 6.29 8-POSITION KEYED PLUG, MECHANICAL SPECIFICATION 127

**FIGURE 6.30 8-POSITION KEYED PLUG, MECHANICAL SPECIFICATION
(CONTINUED) 128**

FIGURE 6.31 8-POSITION KEYED PLUG, PLUG/JACK CONTACT SPECIFICATION 129

FIGURE 6.32 8-POSITION KEYED PLUG, MAXIMUM PLUG SIZE 131

FIGURE 6.33 8-POSITION KEYED PLUG, MINIMUM PLUG SIZE..... 132

FIGURE 6.34 VIEW OF MINIATURE 8-POSITION KEYED JACK..... 133

FIGURE 6.35 8-POSITION KEYED JACK, MECHANICAL SPECIFICATION 134

LIST OF TABLES

**TABLE 4.1 VOLTAGE APPLIED FOR VARIOUS COMBINATIONS OF ELECTRICAL
CONNECTIONS..... 33**

TABLE 4.2 TYPE I E&M, DC POTENTIALS..... 35

TABLE 4.3 TYPE II E&M, DC POTENTIALS 36

TABLE 4.4 TABLE SUMMARY OF RING-TRIP REQUIREMENTS..... 41

TABLE 4.5 PROGRAMMING RESISTORS 45

**TABLE 4.6 ALLOWABLE NET AMPLIFICATION BETWEEN PORTS (SEE NOTES 1, 3, 4,
AND 5) 46**

TABLE 4.7—VALUES FOR K AND AVERAGE OUTPUT POWER.....	59
TABLE 4.8 MINIMUM ADDITIONAL ATTENUATION FOR SUBRATE TERMINAL EQUIPMENT	59
TABLE 4.9 ATTENUATION CURVE FOR SUBRATE TERMINAL EQUIPMENT.....	61
TABLE 4.10 TRANSVERSE BALANCE TEST CRITERIA.....	69
TABLE 4.11 FREQUENCY RANGES OF TRANSVERSE BALANCE REQUIREMENTS FOR EQUIPMENT CONNECTING TO DIGITAL SERVICES.....	73
TABLE 4.12 SIMULATED RINGING VOLTAGES AND IMPEDANCE LIMITATIONS.....	80
TABLE 4.13	83
TABLE A.1 CROSS-REFERENCE TO BODY TEXT	144
TABLE A.2 CROSS-REFERENCE TO FIGURES.....	151
TABLE A.3 CROSS-REFERENCE TO TABLES.....	154

FOREWORD

(This foreword is not part of this Standard.)

The Federal Communications Commission (FCC), in its Report & Order, FCC 00-400, on CC Docket No. 99-216, mandated creation of the Administrative Council for Terminal Attachments (ACTA). In 47 CFR 68.7(b) ACTA was charged to adopt and publish technical criteria to prevent harms to the telephone network submitted to it by standards development organizations accredited by the American National Standards Institute (ANSI).

The first version of this document was an interim standard (IS) whose contents were identical to the criteria in Part 68 of Title 47 of the Code of Federal Regulations at the time the Report & Order was issued. One objective of this updated version is to advance the document from an IS to an ANSI approved standard. Additionally, the following changes have been made in this version:

- 1) The encoded analog content requirement for V.90 and V.92 modems has been relaxed.
- 2) Requirements for stutter dial tone detection devices previously in TIA/EIA-IS-883 have been incorporated.
- 3) Requirements for ADSL modems previously in TIA/EIA-IS-883 have been incorporated and revised.
- 4) Out-of-band metallic voltage limits for analog voice-band and Local Area Data Channel (LADC) TE have been extended from 6 MHz to 30 MHz.
- 5) Transverse balance requirements for ADSL modems and other TE have been clarified.
- 6) Connector wiring configurations have been removed and T1.TR.5-1999 is now referenced.
- 7) Alternative frequency domain signal power limits have been added for digital sub-rate TE.
- 8) The encoded analog content requirement has been extended to other applicable TE .
- 9) Minor editorial corrections and clarifications.

The standard was produced by Working Group TR-41.9.1 of Subcommittee TR-41.9, Technical Regulatory Considerations. It was developed in accordance with ANSI and TIA/EIA procedural guidelines and represents the consensus position of the Working Group and its parent Subcommittee, which served as the formulating group. It has also received the concurrence of Engineering Committee TR-41, User Premises Telecommunications Requirements. Committee approval of this standard does not necessarily imply that all members voted for its approval.

Working Group TR-41.9.1 acknowledges the contribution made by the following individuals in the development of this version of this Standard.

Name	Representing
Larry Bell	ADTRAN, Inc.
Trone T Bishop, Jr	Verizon Communications
Cliff Chamney	Sprint
Phillip Havens	Teccor Electronics
Tim Lawler	Cisco Systems
Henry Mar	Industry Canada
Anh Nguyen	Underwriters Laboratories
Clint Pinkham	ATLINKS USA Inc.
Scott Roleson	Hewlett-Packard Company
John Shinn	Sanmina Homologation Service
Greg Slingerland	Mitel Networks
Tailey Tung	Siemens
Peter Walsh	Paradyne Corporation
Stephen R Whitesell	VTech

Suggestions for improvement of this Standard are welcome. They should be sent to:

Telecommunications Industry Association
Engineering Department
Suite 300
2500 Wilson Boulevard
Arlington, VA 22201

[This page intentionally left blank]

1 GENERAL

1.1 SCOPE

This standard specifies technical criteria for terminal equipment approved in accordance with 47 CFR 68 for direct connection to the public switched telephone network, including private line services provided over wireline facilities owned by providers of wireline telecommunications. These technical criteria are intended to protect the telephone network from the harms defined in 47 CFR 68.3. Conformance to the technical criteria in this standard will not assure compatibility with wireline carrier services.

Except for the grandfathered terminal equipment identified in Annex A, the technical criteria in this standard apply to the direct connection:

- a) Of all terminal equipment to the public switched telephone network, for use in conjunction with all analog services other than party line service;
- b) Of all terminal equipment to channels furnished in connection with foreign exchange lines (customer-premises end), the station end of off-premises stations associated with PBX and Centrex services, trunk-to-station tie lines (trunk end only) and switched service network station lines (CCSA and EPSCS);
- c) Of all PBX (or similar) systems to private line services for tie trunk type interfaces and off premises station lines;
- d) Of all terminal equipment to subrate and 1.544 Mbps digital services;
- e) Of approved terminal equipment or approved protective circuitry to Local Area Data Channels and to channels which are similar to Local Area Data Channels that are obtained as special assemblies;
- f) Of all terminal equipment or systems to voiceband private line channels for 2-point and multipoint private line services (excluding those identified in Category II, AT&T Tariff F.C.C. No. 260 or subsequent revisions) that utilize loop start, ringdown or inband signaling; or voiceband metallic channels;
- g) Of the types of test equipment specified in section 1.3.56;
- h) Of all terminal equipment to Public Switched Digital Service (PSDS) Type I, II, or III;
- i) Of all terminal equipment to the Integrated Services Digital Network (ISDN) Basic Rate Access (BRA) or Primary Rate Access (PRA).
- j) Of all terminal equipment to ADSL services

These criteria apply to terminal equipment approved after publication of this document. Previously approved TE retains its status under the requirements in effect at the time the TE was approved. All TE shall continue to comply with the requirements in effect when the TE was approved. Equipment grandfathered by FCC action is identified in Annex A along with the conditions that allow such TE to be connected without approval.

TE that is modified shall be re-approved under the requirements in effect at the time of the modification, not necessarily those requirements in effect at the time of the prior approval. Except as otherwise specified herein, a modification is any change that affects the compliance of TE to this standard. Repair to TE, where no modification has occurred, does not require re-approval.

Requirements retained by the Commission in 47 CFR Part 68, including hearing aid compatibility and volume control, are not covered in this standard.

Two categories of specifications are used in this standard, mandatory requirements and recommendations. Mandatory requirements are designated by the word "shall" and recommendations by the word "should".

1.2 NORMATIVE REFERENCES

The following standard contains provisions which, through reference in this text, constitute provisions of this Standard. At the time of publication, the editions indicated were valid. All standards are subject to revision, and parties to agreements based on this Standard are encouraged to investigate the possibility of applying the most recent editions of the standards indicated below. ANSI and TIA maintain registers of currently valid national standards published by them. Informative references are provided in Annex B.

- 1) 47 CFR Part 68, Code of Federal Regulations (CFR), Title 47, FCC Part 68, *Connection of Terminal Equipment to the Telephone Network*.
- 2) ITU-T Recommendation G.711, 1993, *General Aspects of Digital Transmission Systems - Terminal Equipment - Pulse Code Modulation (PCM) of Voice Frequencies*.
- 3) TIA/EIA TSB 31-B, Part 68 Rationale and Measurement Guidelines.

1.3 DEFINITIONS

For the purposes of this Standard, the following definitions apply:

NOTE: Informative definitions are included in Annex B.

- 1.3.1 **Approved protective circuitry:** Separate, identifiable and discrete electrical circuitry designed to protect the telephone network from harm, which is approved in accordance with the rules and regulations in 68.7(b) and Subpart C of 47 CFR Part 68.
- 1.3.2 **Approved terminal equipment:** Terminal equipment that is approved in accordance with the rules and regulations in 68.7(b) and Subpart C of 47 CFR Part 68.
- 1.3.3 **Asymmetric Digital Subscriber Line (ADSL) Modem:** A modem having transmit signal characteristics meeting the spectral response and aggregate power level limitations of this standard. The term should be interpreted to include variations such as splitterless ADSL and Rate Adaptive DSL (RADSL) modems that have similar transmit signal characteristics meeting these limitations.
- 1.3.4 **Auxiliary leads:** Terminal equipment leads at the interface, other than telephone connections and leads otherwise defined in this Standard, which leads are to be connected either to common equipment or to circuits extending to central office equipment.
- 1.3.5 **Capture level:** Equipment with AGC (Automatic Gain Control) signal power limiting has virtually no output signal for input levels below a certain value. At some input signal power, the output level will become significant (usually corresponding to the expected output level) for the service application. The input level at which this occurs is defined as the "capture level."
- 1.3.6 **Central-office implemented telephone:** A telephone executing coin acceptance requiring coin service signaling from the central office.
- 1.3.7 **Channel equipment:** Equipment in the private line channel of the telephone network that furnishes telephone tip and ring, telephone tip-1 and ring-1, and other auxiliary or supervisory signaling leads for connection at the private line channel interface (where tip-1 and ring-1 is the receive pair for 4-wire telephone connections).
- 1.3.8 **Coin-implemented telephone:** A telephone containing all circuitry required to execute coin acceptance and related functions within the instrument itself and not requiring coin service signaling from the central office.
- 1.3.9 **Coin service:** Central office implemented coin telephone service.
- 1.3.10 **Companion terminal equipment:** Companion terminal equipment represents the terminal equipment that would be connected at the far end of a network facility and provides the range of operating conditions that the terminal equipment that is being approved would normally encounter.
- 1.3.11 **Continuity leads:** Terminal equipment continuity leads at the network interface designated CY1 and CY2 which are connected to a strap in a series jack configuration for the purpose of determining whether the plug associated with the terminal equipment is connected to the interface jack.

- 1.3.12 **Digital milliwatt:** A digital signal that is the coded representation of a 0 dBm, 1000 Hz sine wave.
- 1.3.13 **Direct connection:** Connection of terminal equipment to the telephone network by means other than acoustic and/or inductive coupling.
- 1.3.14 **Dual Tone Multi Frequency (DTMF):** network control signaling is a method of signaling using the voice transmission path. The method employs 16 distinct signals each composed of two voice band frequencies, one from each of two geometrically spaced groups designated "low group" and "high group." The selected spacing assures that no two frequencies of any group combination are harmonically related.
- 1.3.15 **E&M leads:** Terminal equipment leads at the interface, other than telephone connections and auxiliary leads, which are to be connected to channel equipment solely for the purpose of transferring supervisory signals conventionally known as Types I and II E&M and schematically shown in Figures 1.5 and 1.6.
- 1.3.16 **Encoded analog content:** The analog signal contained in coded form within a data bit stream.
- 1.3.17 **Equivalent power:** The power of the analog signal at the output of a zero level decoder, obtained when a digital signal is the input to the decoder.
- 1.3.18 **Grandfathered terminal equipment:** Terminal equipment of a type allowed to be directly connected to the telephone network under the provisions of 47 CFR Part 68 before the effective date of this standard.
- 1.3.19 **Inband signaling private line interface:** The point of connection between an inband signaling voiceband private line and terminal equipment or systems where the signaling frequencies are within the voiceband. All tip and ring leads shall be treated as telephone connections for the purposes of fulfilling approval conditions.
- 1.3.20 **Instrument-implemented telephone:** A telephone containing all circuitry required to execute coin acceptance and related functions within the instrument itself and not requiring coin service signaling from the central office.
- 1.3.21 **ISDN basic rate interface:** A two-wire interface between the terminal equipment and ISDN BRA. The tip and ring leads shall be treated as telephone connections for the purpose of fulfilling approval conditions.
- 1.3.22 **ISDN Primary Rate Interface:** A four-wire interface between the terminal equipment and 1.544 Mbps ISDN PRA. The tip, ring, tip-1, and ring-1 leads shall be treated as telephone connections for the purpose of fulfilling approval conditions.
- 1.3.23 **Local area data channel (LADC) leads:** Terminal equipment leads at the interface used to transmit and/or receive signals which may require greater than voiceband frequency spectrum over private line metallic channels designated Local Area Data Channels (LADC). These leads shall be treated as "telephone connections" as defined in this section or as tip and ring connections where the term "telephone

connection” is not used.

- 1.3.24 **Local area data channel simulator circuit:** A circuit for connection in lieu of a Local Area Data Channel to provide the appropriate impedance for signal power tests. The schematic of Figure 1.10 is illustrative of the type of circuit that shall be used over the given frequency ranges. When used, the simulator shall be operated over the appropriate range of loop resistance for the equipment under test, under all voltages and polarities that the terminal under test and a connected companion unit are capable of providing.
- 1.3.25 **Longitudinal voltage:** One half of the vector sum of the potential difference between the tip connection and earth ground, and the ring connection and earth ground for the tip, ring pair of 2-wire and 4-wire connections; and, additionally for 4-wire telephone connections, one half of the vector sum of the potential difference between the tip-1 connection and earth ground and the ring-1 connection and earth ground for the tip-1, ring-1 pair (where tip-1 and ring-1 are the receive pair).
- 1.3.26 **Loop simulator circuit:** A circuit that simulates the network side of a 2-wire or 4-wire telephone connection during testing. The required circuit schematics are shown in Figure 1.1 for 2-wire loop or ground start circuits, Figure 1.2 for 2-wire reverse battery circuits, Figure 1.3 for 4-wire loop or ground start circuits, Figure 1.4 for 4-wire reverse battery circuits, and Figure 1.9 for voiceband metallic channels. Figure 1.8 is an alternative termination for use in the 2-wire loop simulator circuits. Other implementations may be used provided that the same dc voltage and current characteristics and ac impedance characteristics will be presented to the equipment under test as are presented in the illustrative schematic diagrams. When used, the simulator shall be operated over the entire range of loop resistance as indicated in the Figures, and with the indicated polarities and voltage limits. Whenever loop current is changed, sufficient time shall be allocated for the current to reach a steady-state condition before continuing testing.
- 1.3.27 **Make-busy leads:** Terminal equipment leads at the network interface designated MB and MB1. The MB lead shall be connected by the terminal equipment to the MB1 lead when the corresponding telephone line is to be placed in an unavailable or artificially busy condition.
- 1.3.28 **Metallic Voltage:** The potential difference between the tip and ring connections for the tip, ring pair of 2-wire and 4-wire connections and additionally for 4-wire telephone connections, between the tip-1 and ring-1 connections for the tip-1, ring-1 pair (where tip-1 and ring-1 are the receive pair).
- 1.3.29 **Multi-port equipment:** Equipment that has more than one telephone connection with provisions internal to the equipment for establishing transmission paths among two or more telephone connections.
- 1.3.30 **Network port:** An equipment port of approved protective circuitry which port faces the telephone network.
- 1.3.31 **Off-premises line simulator circuit:** A load impedance for connection, in lieu of an

off-premises station line, to PBX (or similar) telephone system loop start circuits (Figure 1.7) during testing. The schematic diagram of Figure 1.7 is illustrative of the type of circuit which shall be used; alternative implementations may be used provided that the same dc voltage and current characteristics and ac impedance characteristics of Figure 1.7 shall be presented to the equipment under test as are presented in the illustrative schematic diagram. When used, the simulator shall be operated over the entire range of loop resistances as indicated in Figure 1.7, and with the indicated polarities. Whenever loop current is changed, sufficient time shall be allocated for the current to reach a steady-state condition before continuing testing.

- 1.3.32 **Off-premises station interface:** The point of connection between PBX telephone systems (or similar systems) and telephone company private line communication facilities used to access approved station equipment located off the premises. Equipment leads at this interface are limited to telephone tip and ring leads (designated T(OPS) and R(OPS)) where the PBX employs loop-start signaling at the interface. Unless otherwise noted, all T(OPS) and R(OPS) leads shall be treated as telephone connections for purposes of fulfilling approval conditions.
- 1.3.33 **One-port equipment:** Equipment that has either exactly one telephone connection, or a multiplicity of telephone connections arranged so that no transmission occurs among such telephone connections, within the equipment.
- 1.3.34 **Overload Point:** For signal power limiting circuits incorporating automatic gain control method, the "overload point" is the value of the input signal that is 15 dB greater than the capture level. For signal power limiting circuits incorporating peak limiting method, the "overload point" is defined as the input level at which the equipment's through gain decreases by 0.4 dB from its nominal constant gain.
- 1.3.35 **Power connections:** The connections between commercial power and any transformer, power supply rectifier, converter or other circuitry associated with approved terminal equipment or approved protective circuitry. The following are not power connections. (a) Connections between approved terminal equipment or approved protective circuitry and sources of non-hazardous voltages (see section 4.4.4.4 for a definition of non-hazardous voltages). (b) Conductors that distribute any power within approved terminal equipment or within approved protective circuitry. (c) Green wire ground (the grounded conductor of a commercial power circuit that is UL-identified by a continuous green color).
- 1.3.36 **Private line channel:** Telephone company dedicated facilities and channel equipment used in furnishing private line service from the telephone network for the exclusive use of a particular party or parties.
- 1.3.37 **PSDS Type II Analog Mode Loop Simulator Circuit:** A circuit simulating the network side of the two-wire telephone connection that is used for testing terminal equipment to be connected to the PSDS Type II loops. Figure 1.12 shows the type of circuit that shall be used. Other test circuit configurations may be used provided they operate at the same DC voltage and current characteristics and AC impedance characteristics presented in the illustrated circuit. When utilized, the simulator should be operated over the entire range of loop resistances, and with the indicated voltage

limits and polarities. Whenever the loop current is changed, sufficient time shall be allowed for the current to reach a steady-state condition before continuing testing.

- 1.3.38 **Public Switched Digital Service Type I (PSDS Type I):** This service functions only in a digital mode. It employs a transmission rate of 56 kbps on both the transmit and receive pairs to provide a four-wire full duplex digital channel. Signaling is accomplished using bipolar patterns that include bipolar violations.
- 1.3.39 **Public Switched Digital Service Type II (PSDS Type II):** This service functions in two modes, analog and digital. Analog signaling procedures are used to perform supervisory and address signaling over the network. After an end-to-end connection is established, the switched Circuit Data Service Unit (SCDSU) is switched to the digital mode. The time compression multiplexing (TCM) transmission operated at a digital transmission speed of 144 kbps to provide full-duplex 56 kbps on the two-wire access line.
- 1.3.40 **Public Switched Digital Service Type III (PSDS Type III):** This service functions only in a digital mode. It uses a time compression multiplexing (TCM) rate of 160 kbps, over one pair, to provide two full-duplex channels – an 8 kbps signaling channel for supervisory and address signaling, and a 64 kbps user data channel on a two-wire access line.
- 1.3.41 **Ringdown private line interface:** The point of connection between ringdown voiceband private line service and terminal equipment or systems that provide ringing (20 or 30 Hz) in either direction for alerting only. All tip and ring leads shall be treated as telephone connections for the purposes of fulfilling approval conditions. On 2-wire circuits the ringing voltage is applied to the ring conductor with the tip conductor grounded. On 4-wire circuits the ringing voltage is simplexed on the tip and ring conductors with ground simplexed on the tip-1 and ring-1 conductors.
- 1.3.42 **Specialty adapters:** Adapters that contain passive components such as resistive pads or bias resistors typically used for connecting data equipment having fixed-loss loop or programmed data jack network connections to key systems or PBXs.
- 1.3.43 **Stutter dial tone:** Interrupted dial tone. Typically, the cadence is 0.1 s on, 0.1 s off and the interruptions are only for the first few seconds of dial tone. Stutter dial tone is used to provide an audible signal to the equipment user in support of certain network features.
- 1.3.44 **Stutter dial tone detection device:** Terminal equipment that is designed to automatically go off-hook and determine the presence or absence of stutter dial tone.
- 1.3.45 **Sub-rate digital service:** A digital service providing for the full-time simultaneous two-way transmission of digital signals at synchronous speeds of 2.4, 4.8, 9.6 or 56 kbps.
- 1.3.46 **Switched Circuit Data Service Unit (SCDSU):** A CPE device, with PSDS functionality, located between the Network Interface and the data terminal equipment. (It also is sometimes referred to as Network Channel Terminating

Equipment).

- 1.3.47 **Telephone Connection:** Connection to telephone network tip and ring leads for 2-wire and 4-wire connections and, additionally, for 4-wire telephone connections, tip-1 and ring-1 leads and all connections derived from these leads. The term “derived” as used here means that the connections are not separated from telephone tip and ring or from telephone tip-1 and ring-1 by a sufficiently protective barrier. Provisions of this Standard that apply specifically to telephone network tip and ring pairs shall also apply to telephone network tip-1 and ring-1 pairs unless otherwise specified. In 4-wire connections, leads designated tip and ring at the interface are for transmitting voice frequencies toward the network and leads designated tip-1 and ring-1 at the interface are for receiving voice frequencies from the network.
- 1.3.48 **Telephone Network:** The public switched network and those private lines which are defined in section 1.1 of this standard.
- 1.3.49 **Terminal Equipment (TE):** Communications equipment located on customer premises at the end of a communications link, that is used to permit the stations involved to accomplish the provision of telecommunications or information services.
- 1.3.50 **Terminal Port:** An equipment Port of approved protective circuitry which port faces remotely-located terminal equipment.
- 1.3.51 **Test Equipment:** Equipment connected at the customer’s premises that is used on the customer’s side of the network interfaces to measure characteristics of the telephone network, or to detect and isolate a communications fault between a terminal equipment entity and the telephone network. Approval is required for test equipment capable of functioning as portable traffic recorder or equipment capable of transmitting or receiving test tones; except approval is not required for devices used by telephone companies solely for network installation and maintenance activities such as hand-held data terminals, linesmen’s handsets, and subscriber line diagnostic devices.
- 1.3.52 **Tie trunk transmission interfaces:**
- a) **2-Wire:** A 2-wire transmission interface with a path that is essentially lossless (except for 2-dB switched pad operation, or equivalent) between the interface and the 2-wire or 4-wire, transmission reference point of the terminal equipment.
 - b) **4-Wire lossless:** A 4-wire transmission interface with a path that is essentially lossless (except for 2 dB switched pad operation, or equivalent) between the interface and the 2-wire or 4-wire transmission reference point of the terminal equipment; and
 - c) **Direct Digital Interface:** An interface between a digital PBX and a digital transmission facility.
 - d) **Digital Tandem 4-Wire Interface:** A 4-wire digital interface between digital terminal equipment and a digital transmission facility operating at 1.544 Mbps or sub-rate connecting terminal equipment that provide tandem connections.

- e) **Digital Satellite 4-wire Interface:** A 4-wire digital interface between digital terminal equipment and a digital transmission facility operating at 1.544 Mbps or sub-rate connecting terminal equipment that does not provide tandem connections to other digital terminal equipment.
- 1.3.53 **Voiceband:** For the purpose of this standard, the voiceband for analog interfaces is the frequency band from 200 Hz to 3995 Hz.
- 1.3.54 **Voiceband metallic private line channel interface:** The point of connection between a voiceband metallic private line channel and terminal equipment or systems where the network does not provide any signaling or transmission enhancement. Approved terminal equipment or systems may use convenient signaling methods so long as the signals are provided in such a manner that they cannot interfere with adjacent network channels. All tip and ring leads shall be treated as telephone connections for the purpose of fulfilling approval conditions.
- 1.3.55 **Zero Level Decoder:** The zero level de-coder shall comply with the $\mu = 255$ PCM encoding law as specified in ITU-T G.711 for voiceband encoding and decoding. See also Figure 1.11
- 1.3.56 **1.544 Mbps digital CO 4-wire interface:** A 4-wire digital interface between digital terminal equipment and a digital transmission facility operating at 1.544 Mbps connecting to a serving central office.
- 1.3.57 **1.544 Mbps digital service:** A full-time dedicated private line circuit used for the transmission of digital signals at a speed of 1.544 Mbps.

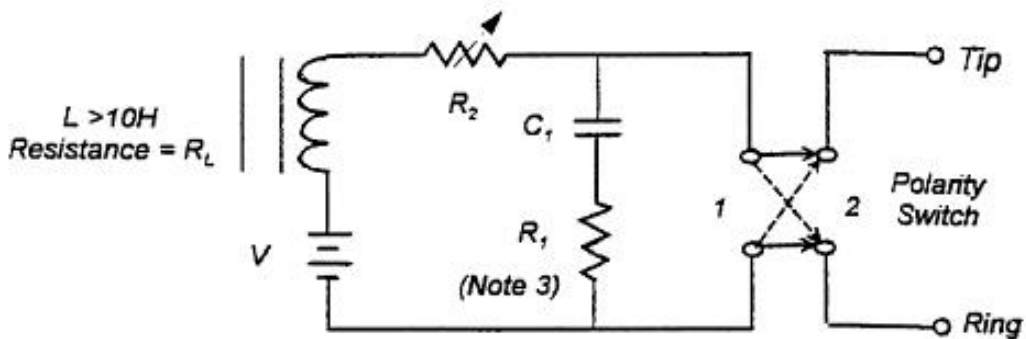

$$C_1 = 500 \mu\text{F} - 10\% + 50\%$$

$$R_1 = 600 \Omega \pm 1\%$$

Condition	V (V)	Switch Position For Test	$R_2 + R_L$
1	Min 42.5	Both	Continuously variable over 400 to 1740 Ω
	Max 56.5		
2	105	2	2000 Ω

NOTES:

- Means shall be used to generate, at the point of tip and ring connections to the terminal equipment or protective circuitry, the parameters of dc line current and ac impedance that are generated by the illustrative circuit depicted above (as appropriate for the equipment under test).
- In the Transverse Balance Limitation section 4.6, the use of the "dc portion of the loop simulator circuit" is specified. In such case components of R_1 and C_1 shall be removed.
- Tests for compliance shall be made with either $R_1 = 600 \Omega$ or R_1 replaced by the alternative configuration shown in Figure 1.8.

Figure 1.1 2-Wire Loop Simulator for Loop Start and Ground Start Circuits

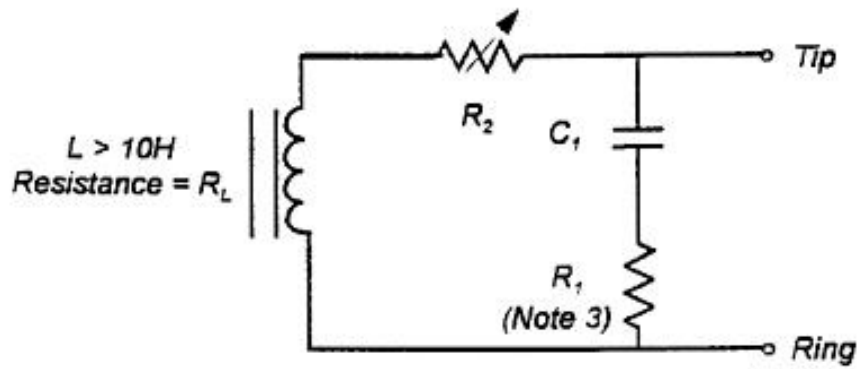

$$C_1 = 500 \mu F - 10\% + 50\%$$

$$R_1 = 600 \Omega \pm 1\%$$

$R_2 + R_L$
Continuously variable over 400 to 2450 Ω

NOTE: The notes for Figure 1.1 also apply to this Figure.

Figure 1.2 Loop Simulator for Reverse Battery Circuits

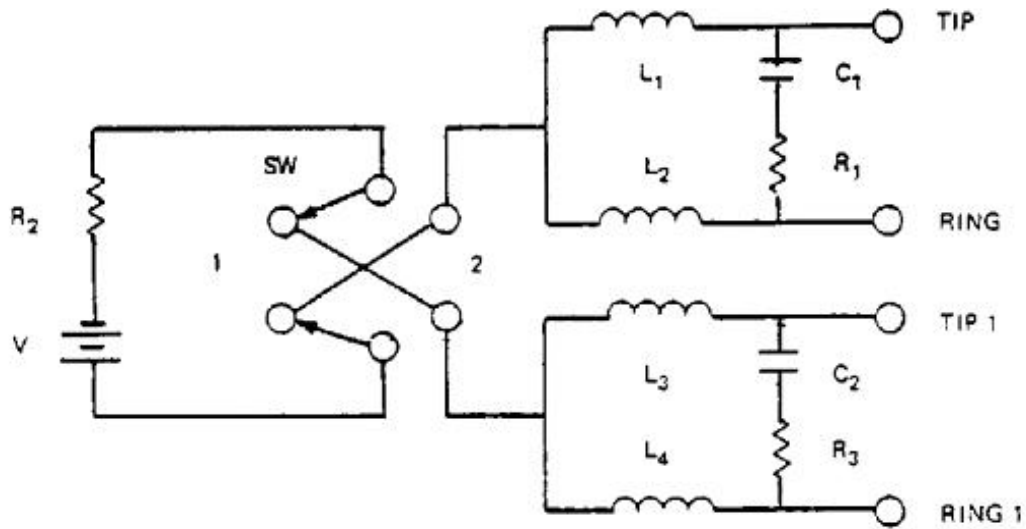

SW = Polarity Switch

$L_1 = L_2 = L_3 = L_4 > 5 H$ (Resistance = $R_{L1}, R_{L2}, R_{L3}, R_{L4}$)

$R_1 = R_3 = 600 \Omega \pm 1\%$

$C_1 = C_2 = 500 \mu F - 10\% + 50\%$

Condition	V (Volts)	Switch Position For Test	$R_2 + R_L$
1	Min = 42.6 Max = 56.5	Both	Continuously Variable over 400 to 1740 Ω
2	105	2	2000 Ω

$$R_L = \frac{R_{L1}R_{L2}}{R_{L1} + R_{L2}} + \frac{R_{L3}R_{L4}}{R_{L3} + R_{L4}}$$

Figure 1.3 Loop Simulator Circuit for 4-Wire Loop Start and Ground Start

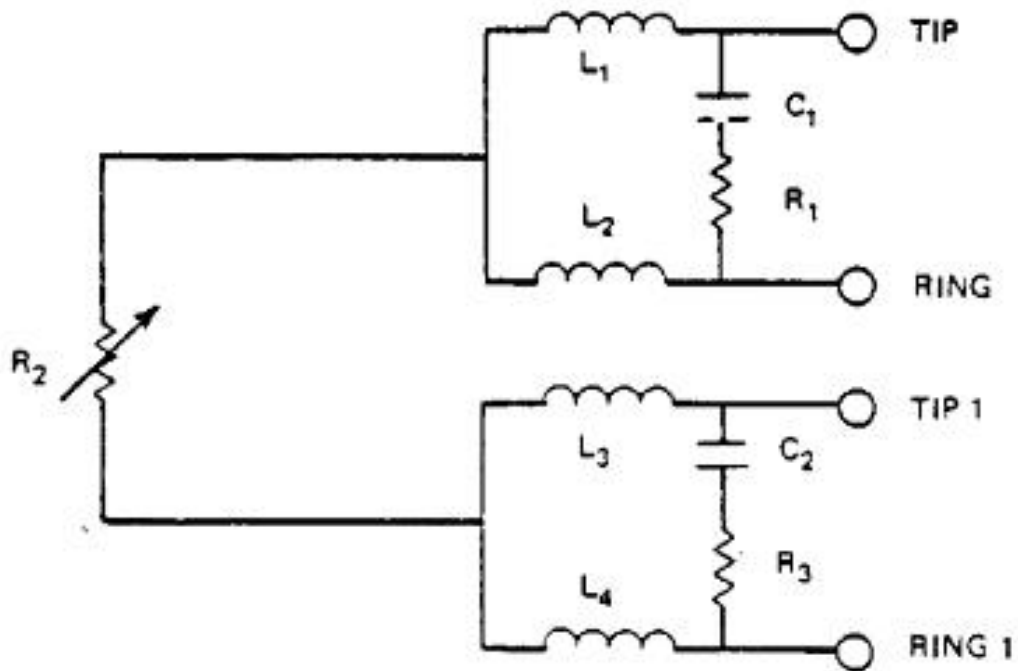

$L_1 = L_2 = L_3 = L_4 > 5 \text{ H}$ (Resistance = $R_{L1}, R_{L2}, R_{L3}, R_{L4}$)
 $R_1 = R_3 = 600 \Omega \pm 1\%$
 $C_1 = C_2 = 500 \mu\text{F} - 10\% + 50\%$

$R_2 + R_L$
Continuously variable over 400 to 2450 Ω

$$R_L = \frac{R_{L1}R_{L2}}{R_{L1} + R_{L2}} + \frac{R_{L3}R_{L4}}{R_{L3} + R_{L4}}$$

Figure 1.4 Loop Simulator Circuit for 4-Wire Reverse Battery Circuits

Approved Terminal Equipment on "A" Side of Interface

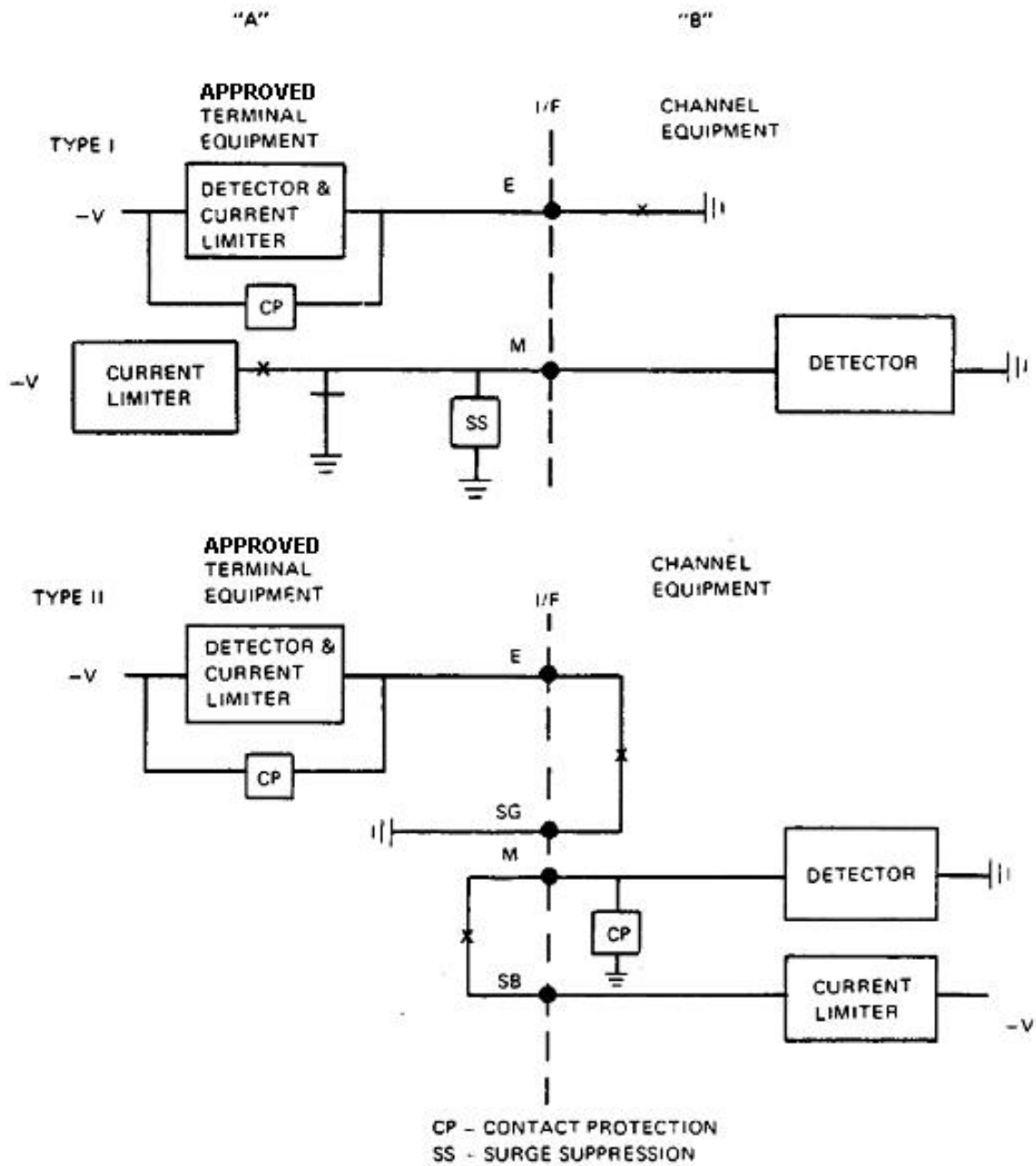

Figure 1.5 E&M Types I & II Signaling

Approved Terminal Equipment on "B" Side of Interface

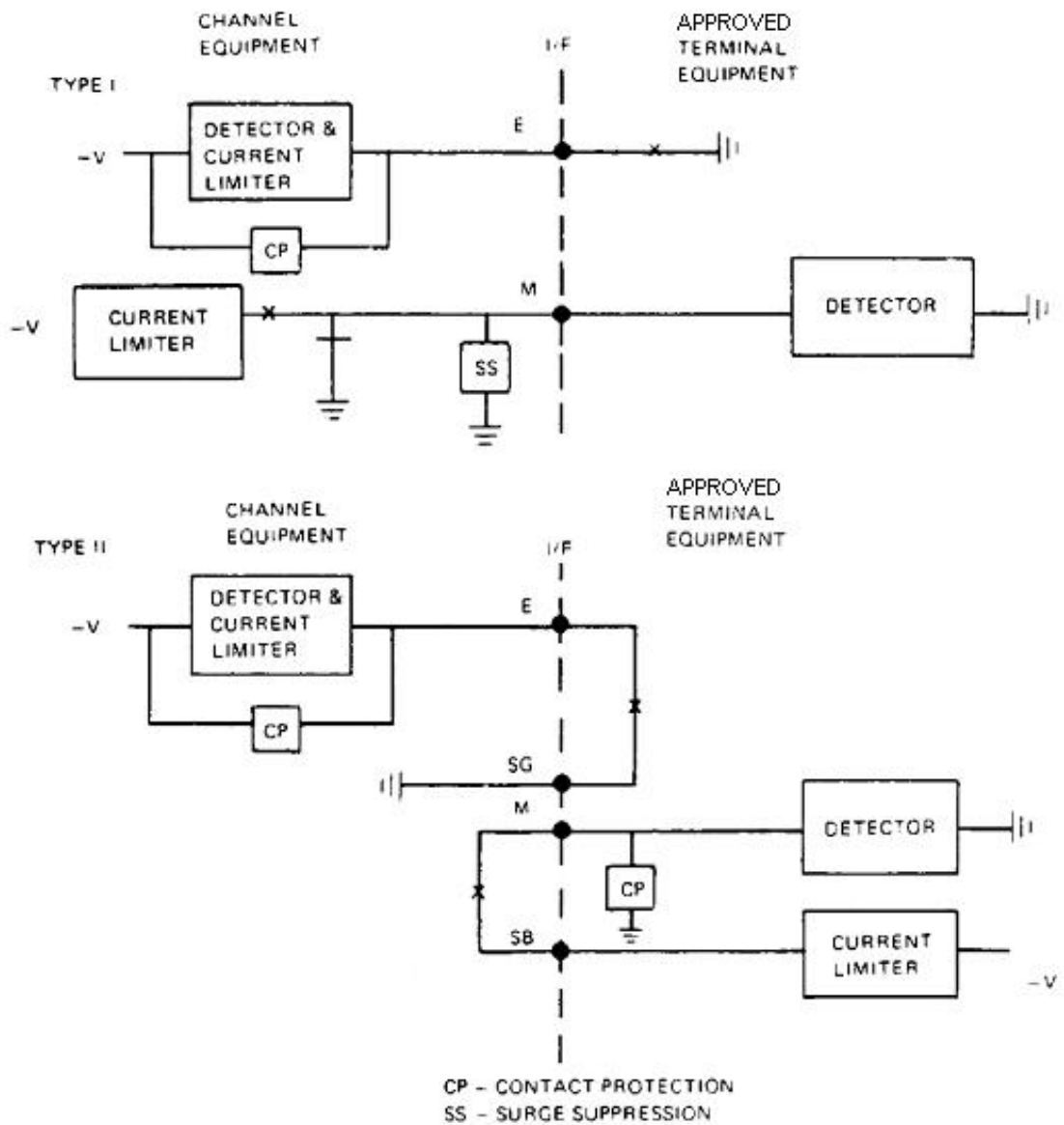
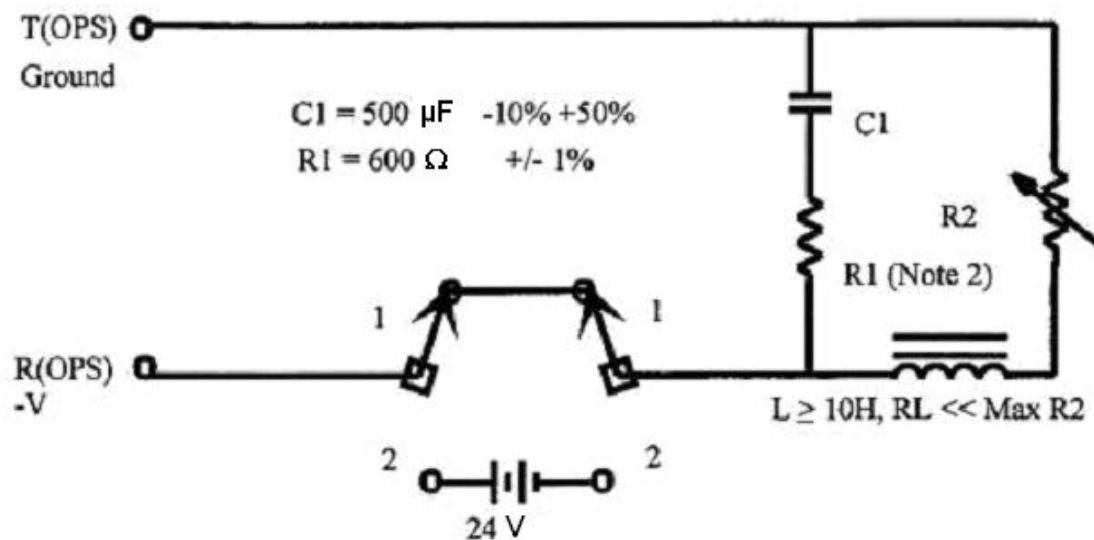

Figure 1.6 E&M Types I & II Signaling



Condition	Switch Position For Test	Class A	R ₂ + R _L continuously variable over the following range	
			Class B	Class C
1	1	Up to 200 Ω	Up to 800 Ω	Up to 1800 Ω
2	2	N.A.	200 to 2300 Ω	900 to 3300 Ω

The minimum current for all resistance ranges shall be 16 mA.

NOTES:

1. Means shall be used to generate, at the point of tip (T OPS) and ring (R OPS) connections to the PBX, the range of resistance and impedance that are employed by the illustrative circuit depicted above.
2. In the Transverse Balance Limitation section 4.6 the use of the dc portion of the loop simulator is specified. In such cases, R₁ and C₁ shall be removed.
3. Tests for compliance shall be made with either R₁ = 600 Ω or replaced by the alternative termination specified in Figure 1.8.

Figure 1.7 Off Premises Loop Simulator

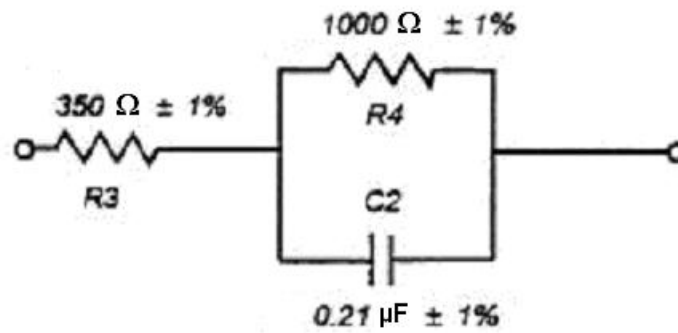

NOTE: When this alternative termination is used during signal power compliance testing, it shall replace R_1 (600Ω) in the loop simulator circuit.

Figure 1.8 Alternative Termination

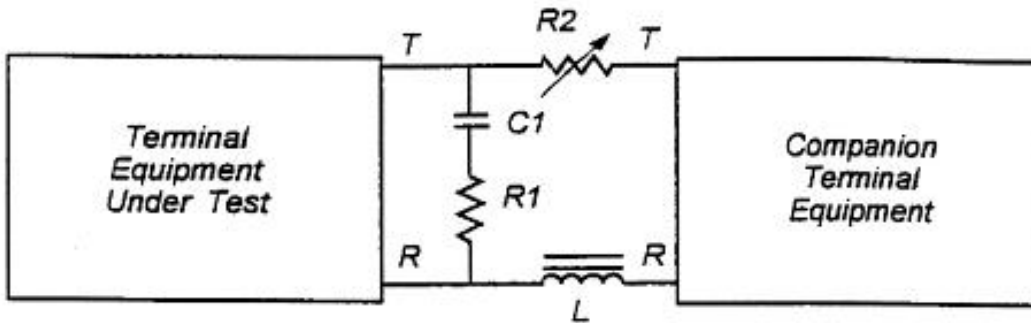

$$C_1 = 500 \mu F - 10\% + 50\%$$

$$R_1 = 600 \Omega \pm 1\%$$

$$L = 10 H, \text{ Resistance} = R_L$$

$R_2 + R_L$ are continuously variable from R_L to R_X ;

Where $R_X =$ Signaling range of Equipment Under Test, and
 $R_L \ll R_X$

NOTE: For transverse balance measurements (section 4.6), the dc portion of the loop simulator shall be provided by removing R_1 and C_1 . Companion terminal equipment grounds (including power supplies) shall be isolated from transverse balance circuit grounds.

Figure 1.9 Loop Simulator Circuit – Voiceband Metallic Channels

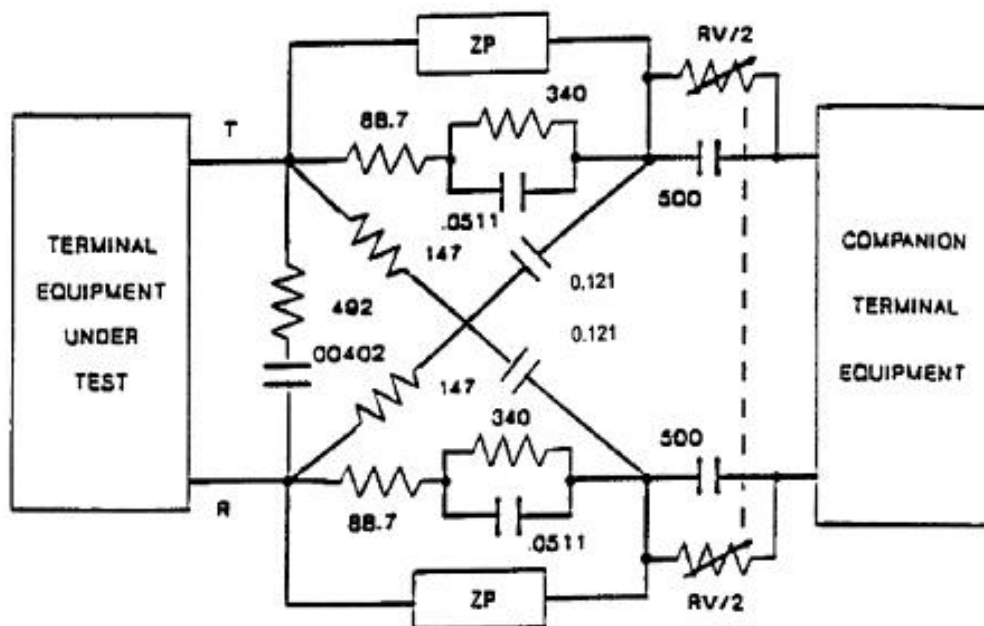

Resistances (Ω), Capacitances (μF), Tolerances ($\pm 2\%$)

$R_V + R_P = 50$ thru 3000Ω .

Z_P is the magnitude of the lowpass filter impedance that is (25Ω dc) $3 \text{ k}\Omega$ from 10 Hz to 6 kHz .

$R_P/2 = \text{dc resistance of lowpass filter, } Z_P \text{ in parallel with } 428.7 \Omega$.

Figure 1.10 LADC Impedance Simulator for Metallic Voltage Tests

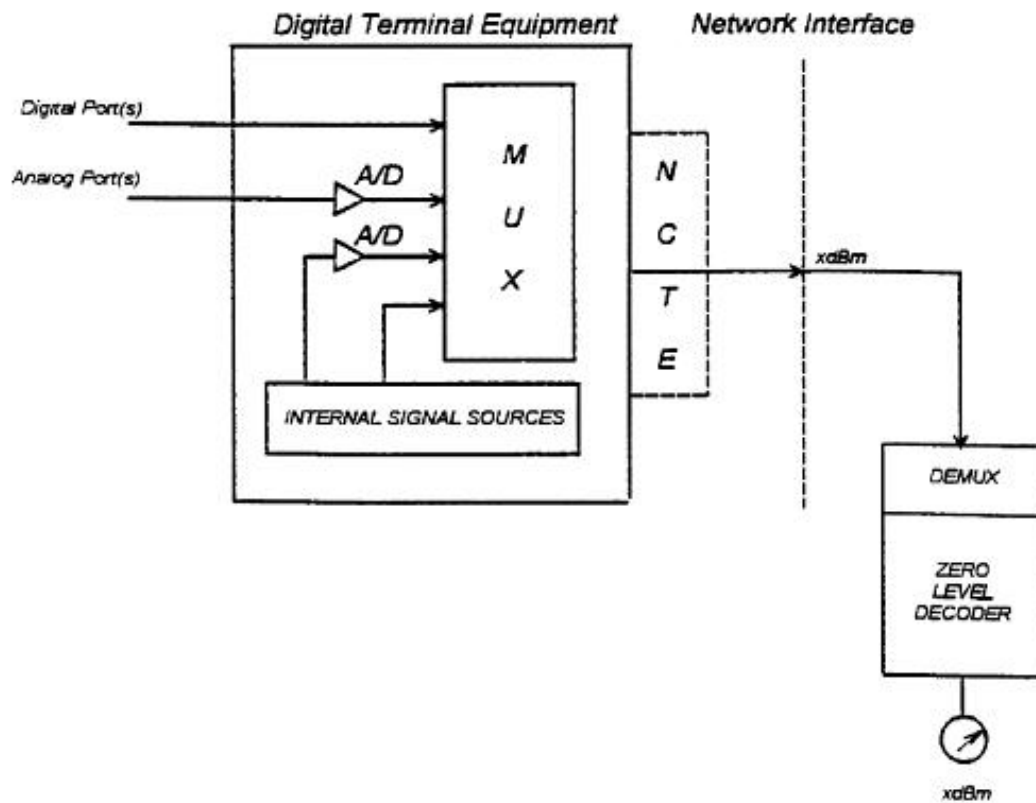

NOTES: The decoder shall have a resistive 600 Ω output impedance and shall be terminated in a resistance of 600 Ω.

The Zero Level Decoder shall comply with the 255 Pulse code modulation encoding μ -law specified in ITU-T Recommendation G.711.

Figure 1.11 Zero Level Decoder Test Configuration for Sub-rate and 1.544 MBPS Digital Channels

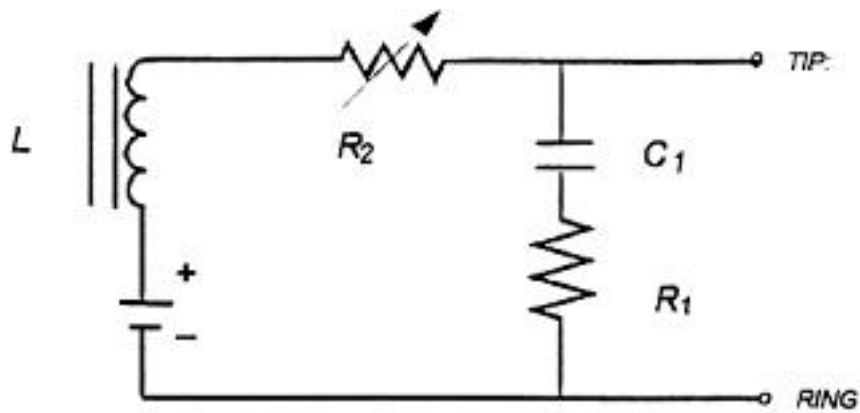

$L \geq 10 \text{ H}$ (Resistance = R_L)

$R_1 = 600 \Omega \pm 1\%$

$C_1 = 500 \mu\text{F}, -10\%, +50\%$

Test Conditions for Analog Mode		
V (Volts)		$R_2 + R_L (\Omega)$
Min	Max	Continuously Variable
36	46	610 to 1510

Figure 1.12 Simulator Circuit for PSDS Type II in Analog Mode

2 CONDITIONS ON USE OF TERMINAL EQUIPMENT

The conditions on use of the Terminal Equipment are provided in Subpart B of 47 CFR Part 68.

This page left intentionally blank.

3 TERMINAL EQUIPMENT APPROVAL PROCEDURES

The Terminal Equipment Approval Procedures are provided in Subpart C of 47 CFR Part 68.

This page left intentionally blank.

4 TECHNICAL REQUIREMENTS

4.1 LABELING

The labeling of Terminal Equipment shall follow the requirements prescribed by the Administrative Council on Terminal Attachment (ACTA).

4.2 ENVIRONMENTAL SIMULATION

Unpackaged Approved Terminal Equipment and Approved Protective Circuitry shall comply with all the criteria specified in this standard, both prior to and after application of the mechanical and electrical stresses specified in this section 4.2, notwithstanding that certain of these stresses may result in partial or total destruction of the equipment. Both telephone line surges, Type A and Type B, shall be applied as specified in sections 4.2.2 and 4.2.3. Different failure criteria apply for each surge type.

4.2.1 Mechanical Shock

- 4.2.1.1 Hand-Held Items Normally Used at Head Height: 18 random drops from a height of 1.5 meters onto concrete covered with 3 mm asphalt tile or similar surface.
- 4.2.1.2 Table (Desk) - Top Equipment 0–5 kg: Six random drops from a height of 750 mm onto concrete covered with 3 mm asphalt tile or similar surface.
- 4.2.1.3 The drop tests specified in section 4.2.1 shall be performed as follows: The unit shall be positioned prior to release to ensure as nearly as possible that for every six drops there is one impact on each of the major surfaces and that the surface to be struck is approximately parallel to the impact surface.

4.2.2 Telephone Line Surge – Type A

4.2.2.1 Metallic:

- 4.2.2.1.1 Two metallic voltage surges (one of each polarity) shall be applied between any pair of connections on which lightning surges may occur; this includes:
 - a) tip to ring;
 - b) tip-1 to ring-1; and
 - c) For a 4-wire connection that uses simplex pairs for signaling, tip to ring-1 and ring to tip-1.

4.2.2.1.2 The surge shall have an open circuit voltage waveform in accordance with Figure 4.2 having a front time (t_f) of 10 μ s maximum and a decay time (t_d) of 560 μ s minimum, and shall have a short circuit current waveshape in accordance with Figure 4.3 having a front time (t_f) of 10 μ s maximum and a decay time (t_d) of 560 μ s minimum. The peak voltage shall be at least 800 V and the peak short circuit current shall be at least 100 A.

4.2.2.1.3 Surges shall be applied as follows:

- a) With the equipment in all states that can affect compliance with the requirements of this standard. If an equipment state cannot be achieved by normal means of power, it shall be achieved artificially;
- b) With equipment leads not being surged (including telephone connections, auxiliary leads, and terminals for connection to non-approved equipment) terminated in a manner that occurs in normal use;
- c) Under reasonably foreseeable disconnection of primary power sources, with primary power cords plugged and unplugged, if so configured.

4.2.2.2 Longitudinal:

4.2.2.2.1 Two longitudinal voltage surges (one of each polarity) shall be applied to any pair of connections on which lightning surges may occur. This includes the tip-ring pair and the tip-1—ring-1 pair, to earth grounding connections, and to all leads intended for connection to non-approved equipment, connected together. Surges shall be applied as follows:

- a) With the equipment in all states that can affect compliance with the requirements of this Standard. If an equipment state cannot be achieved by normal means of power, it shall be achieved artificially;
- b) With equipment leads not being surged (including telephone connections, auxiliary leads, and terminals for connection to non-approved equipment) terminated in a manner that occurs in normal use;
- c) Under reasonably foreseeable disconnection of primary power sources, as for example, with primary power cords plugged and unplugged.

4.2.2.2.2 The surge shall have an open circuit voltage waveform in accordance with Figure 4.2 with a front time (t_f) of 10 μ s maximum and a decay time (t_d) of 160 μ s minimum, and shall have a short circuit current waveshape in accordance with Figure 4.3 having a front time (t_f) of 10 μ s maximum and a decay time (t_d) of 160 μ s minimum. The peak voltage shall be at least 1500 V and the peak short circuit current shall be at least 200 A.

4.2.2.3 Failure Modes resulting from application of Type A telephone line surges: Regardless of operating state, equipment and circuitry are allowed to be in violation of the transverse balance requirements of sections 4.6.2 and 4.6.3 and, for terminal equipment connected to Local Area Data Channels, the longitudinal signal power requirements of section 4.5.5.2 if:

- a) Such failure results from an intentional, designed failure mode that has the effect of connecting telephone or auxiliary connections with earth ground; and,
- b) If such a failure mode state is reached, the equipment is designed so that it would become substantially and noticeably unusable by the user, or an indication is given (e.g. an alarm), in order that such equipment can be immediately disconnected or repaired.

The objective of (a) is to allow for safety circuitry to either open-circuit, which would cause a permanent on-hook condition, or to short-circuit to ground, as a result of an energetic lightning surge. Off-hook tests would be unwarranted if the off-hook state cannot be achieved. A short to ground has the potential for causing interference resulting from longitudinal imbalance, and therefore designs shall be adopted which will cause the equipment either to be disconnected or repaired rapidly after such a state is reached, should it occur in service.

4.2.3 Telephone Line Surge – Type B

4.2.3.1 Metallic:

Two metallic voltage surges (one of each polarity) shall be applied to equipment between any pair of connections on which lightning surges may occur; this includes:

- a) tip to ring;
- b) tip-1 to ring-1; and
- c) For a 4-wire connection that uses simplex pairs for signaling, tip to ring-1 and ring to tip-1.

The surge shall have an open circuit voltage waveform in accordance with Figure 4.2 having a front time (t_f) of $9 \mu\text{s} \pm 30\%$ and a decay time (t_d) of $720 \mu\text{s} \pm 20\%$ and shall have a short circuit current waveshape in accordance with Figure 4.3 having a front time (t_f) of $5 \mu\text{s} \pm 30\%$ and a decay time (t_d) of $320 \mu\text{s} \pm 20\%$. The peak voltage shall be at least 1000 V and the peak short circuit current shall be at least 25 A. The wave shapes are based on the use of ideal components in Figure 4.1 with S2 in Position M. Surges shall be applied:

- a) With the equipment in all states that can affect compliance with the requirements of this standard. If an equipment state cannot be achieved by normal means of power, it shall be achieved artificially.
- b) With equipment leads not being surged (including telephone connections, auxiliary leads, and terminals for connection to non-approved equipment) terminated in a manner that occurs in normal use.

- c) Under reasonably foreseeable disconnection of primary power sources, as for example, with primary power cords plugged and unplugged.

4.2.3.2 Longitudinal:

Two longitudinal voltage surges (one of each polarity) shall be applied to any pair of connections on which lightning surges may occur. This includes the tip-ring pair and the tip-1 ring-1 pair to earth grounding connections and to all leads intended for connection to non-approved equipment, connected together. Surges shall be applied as follows:

- a) With the equipment in all states that can affect compliance with the requirements of this Standard. If an equipment state cannot be achieved by normal means of power, it shall be achieved artificially.
- b) With equipment leads not being surged (including telephone connections, auxiliary leads, and terminals for connection to non-approved equipment) terminated in a manner that occurs in normal use.
- c) Under reasonably foreseeable disconnection of primary power sources, as for example with primary power cords plugged and unplugged.

For each output lead of the surge generator, with the other lead open, the surge shall have an open circuit voltage waveform in accordance with Figure 4.2 having a front time (t_f) of $9 \mu\text{s} \pm 30\%$ and a decay time (t_d) of $720 \mu\text{s} \pm 20\%$ and shall have a short circuit current waveshape in accordance with Figure 4.3 having a front time (t_f) of $5 \mu\text{s} \pm 30\%$ and a decay time (t_d) of $320 \mu\text{s} \pm 20\%$. The peak voltage shall be at least 1500 V and the peak short circuit current shall be at least 37.5 A. The wave shapes are based on the use of ideal components in Figure 4.1 with S2 in Position L.

- #### 4.2.3.3 Failure Modes resulting from application of Type B telephone line surges: Approved terminal equipment and approved protective circuitry shall withstand the energy of Surge Type B without causing permanent opening or shorting of the interface circuit and without sustaining damage that will affect compliance with this standard.

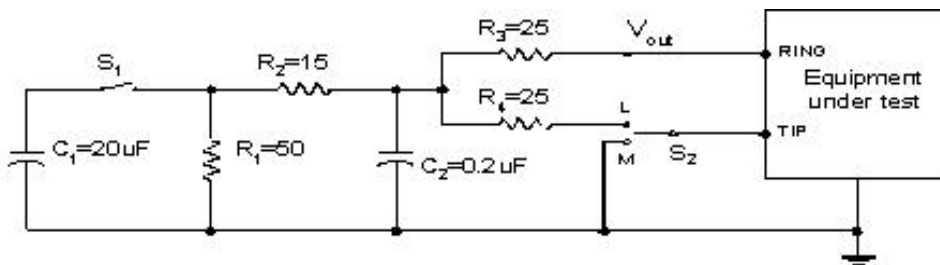

Figure 4.1 Simplified Surge Generator

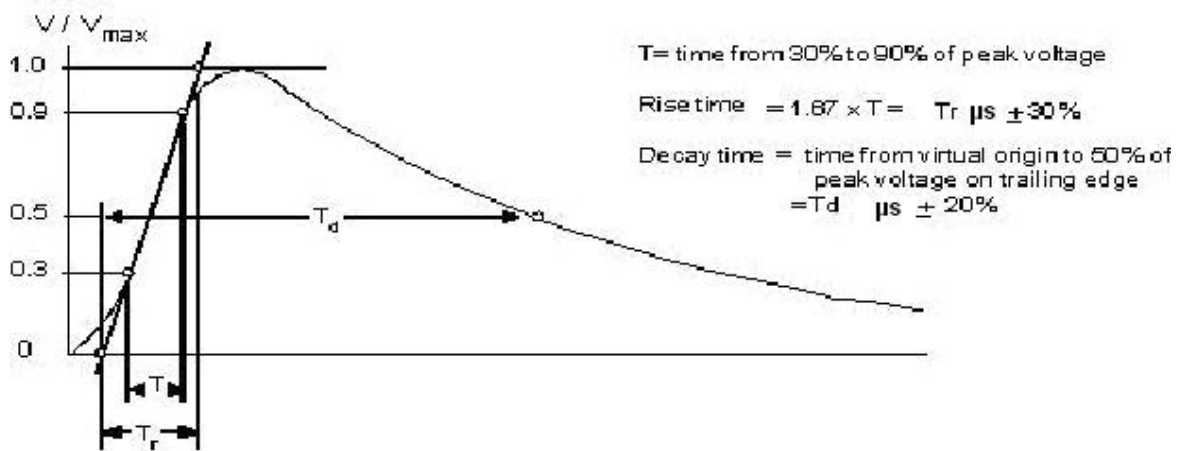

Figure 4.2 Open Circuit voltage Waveshape, $T_r \times T_d$

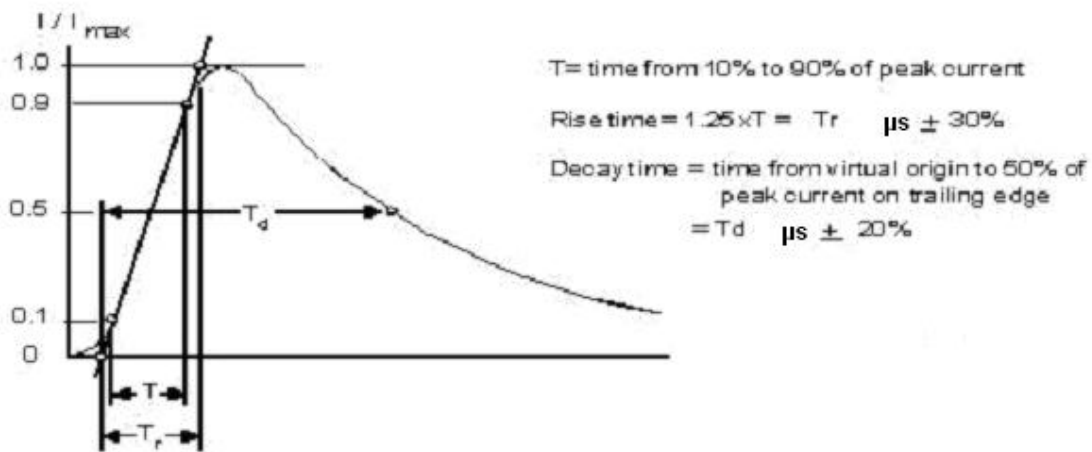

Figure 4.3 Short Circuit Current Waveshape, $T_r \times T_d$

4.2.4 Power Line Surge

4.2.4.1 Six power line surges (three of each polarity) shall be applied between the phase and neutral terminals of the ac power line while the equipment is being powered. The surge shall have an open circuit voltage waveform in accordance with Figure 4.2 having a front time (t_f) of 2 μ s maximum and a decay time (t_d) of 10 μ s minimum and shall have a short circuit current waveshape in accordance with Figure 4.3 with a front time (t_f) of 2 μ s maximum and a decay time (t_d) of 10 μ s minimum. The peak voltage shall be at least 2500 V and the peak short circuit current shall be at least 1000 A. Surges shall be applied:

4.2.4.1.1 With the equipment in all states that can affect compliance with the requirements of this Standard. If an equipment state cannot be achieved by normal means of power, it may be achieved artificially;

4.2.4.1.2 With equipment leads not being surged (including telephone connections, auxiliary leads, and terminals for connection to non-approved/non-certified equipment) terminated in a manner that occurs in normal use.

4.2.4.2 Failure Modes resulting from application of power line surge. Approved terminal equipment and approved protective circuitry shall comply with all the criteria in this standard, both prior to and after the application of the power line surge specified in 4.2.4, notwithstanding that this surge may result in partial or total destruction of the equipment under test.

4.3 LEAKAGE CURRENT LIMITATIONS

Approved terminal equipment and approved protective circuitry shall have a voltage applied to the combination of points listed in the table below. The test voltage shall be ac of 50 or 60 Hz rms.

- a) All telephone connections;
- b) All power connections;
- c) All possible combinations of exposed conductive surfaces on the exterior of such equipment or circuitry including grounding connection points, but excluding terminals for connection to other terminal equipment;
- d) All terminals for connection to approved protective circuitry or non-approved equipment;
- e) All auxiliary lead terminals;
- f) All E&M lead terminals, and
- g) All PR, PC, CY1 and CY2 leads.

Table 4.1 Voltage Applied For Various Combinations Of Electrical Connections

Voltage Source Connected Between:	AC Value*
(a) and (b) (See Notes 1, 2, 3)	1500
(a) and (c) (See Notes 1, 2)	1000
(a) and (d) (See Notes 1, 2)	1000
(a) and (e) (See Notes 1, 2)	1000
(a) and (f) (See Notes 1, 2)	1000
(a) and (g) (See Notes 1, 2)	1000
(b) and (c) (See Note 3)	1500
(b) and (d) (See Note 3)	1500
(b) and (e) (See Note 3)	1500
(b) and (f) (See Note 3)	1500
(b) and (g) (See Note 3)	1500
(c) and (e) (See Notes 1,2)	1000
(c) and (f) (See Notes 1,2)	1000
(d) and (e) (See Note 2)	1000
(d) and (f) (See Note 2)	1000
(e) and (f) (See Note 2)	1000

* Value to which test voltage is gradually increased.

- NOTES:**
1. Gradually increase the voltage from zero to the values listed in the Table over a 30-second time period, and then maintain the voltage for one minute. The current in the mesh formed by the voltage source and these points shall not exceed 10 mA_P at any time during this 90-second interval.
 2. Equipment states necessary for compliance with the requirements of this section that cannot be achieved by normal means of power shall be achieved artificially by appropriate means.
 3. A telephone connection, auxiliary lead, or E&M lead that has an intentional dc conducting path to earth ground at operational voltages (such as a ground start lead), may be excluded from the leakage current test in that operational state. Leads or connections excluded for this reason shall comply with the requirements of 4.4.5.1.
 4. A telephone connection, auxiliary lead, or E&M lead that has an intentional dc conducting path to earth ground for protection purposes at the leakage

current test voltages (such as through a surge suppressor), may have the component providing the conducting path removed from the equipment for the leakage current test in that operational state. Components removed for this reason shall comply with the requirements of section 4.4.5.2.

5. Filter paths, such as capacitors used in EMI filters, are left in place during leakage current testing, since these components can be a path for excessive leakage.

6. For multi-unit equipment inter-connected by cables, that is evaluated and approved as an interconnected combination or assembly, the specified 10 mA peak maximum leakage current limitation other than between power connection points and other points, may be increased as described here to accommodate cable capacitance. The leakage current limitation may be increased to $(10N + 0.13L)$ mA_P where L is the length of interconnecting cable in the leakage path in meters and N is the number of equipment units that the combination or assembly will place in parallel across a telephone connection.

7. RF filters and surge protectors on the line side of power supplies may be disconnected before making leakage measurements (section 4.3). As an alternative to disconnecting these filters and surge protectors, this measurement may be made using a dc voltage equal to the peak ac test voltage.

4.4 HAZARDOUS VOLTAGE LIMITATIONS

4.4.1 General: Under no condition of failure of approved terminal equipment or approved protective circuitry that can be conceived to occur in the handling, operation or repair of such equipment or circuitry, shall the open circuit voltage on telephone connections exceed $70 V_P$ after one second, except for voltages for network control signaling, alerting and supervision.

4.4.1.1 Type I E&M Leads. Approved terminal equipment shall comply with the following requirements for terminal equipment on the "A" or "B" side of the interface as shown in Figure 1.5 and Figure 1.6.

4.4.1.1.1 The dc current on the E lead shall not exceed 100 mA.

4.4.1.1.2 The maximum dc potentials to ground shall not exceed the following when measured across a resistor of $20 \text{ k}\Omega \pm 10\%$:

Table 4.2 Type I E&M, DC Potentials

	E LEAD	M LEAD
TE on "B" side originates signals to network on E lead.	$\pm 5 \text{ V}$	$\pm 5 \text{ V}$
TE on "A" side originates signals to network on M lead	-56.5 V; no positive potential with respect to ground.	-56.5 V; no positive potential with respect to ground.

- 4.4.1.2 The maximum ac potential between E&M leads and ground reference shall not exceed $5 V_P$.
- 4.4.1.2.1 M lead protection shall be provided so that voltages to ground do not exceed 60 V. For relay contact implementation, a power dissipation capability of 0.5 W shall be provided in the shunt path.
- 4.4.1.2.2 If the approved terminal equipment contains an inductive component in the E lead, it shall assure that the transient voltage across the contact as a result of a relay contact opening does not exceed the following voltage and duration limitations:
- 300 V_P ,
 - A rate of change of one V per μs , and
 - 60 V level after 20 ms.
- 4.4.1.3 Type II E&M Leads. Approved terminal equipment shall comply with the following requirements:
- 4.4.1.3.1 For terminal equipment on the "A" side of the interface, the dc current in the E lead shall not exceed 100 mA. The maximum ac potential between the E lead and ground shall not exceed $5 V_P$.
- 4.4.1.3.2 For terminal equipment on the "B" side of the interface, the dc current in the SB lead shall not exceed 100 mA. The maximum ac potential between the SB lead and ground shall not exceed $5 V_P$.
- 4.4.1.3.3 The maximum dc potentials to ground shall not exceed the following when measured across a resistor of $20 \text{ k}\Omega \pm 10\%$:

Table 4.3 Type II E&M, DC Potentials

	E lead	M lead	SB lead	SG lead
TE on "B" side of the interface originates signals to network on E lead.	$\pm 5 \text{ V}$	$\pm 5 \text{ V}$	-56.5 V; no positive potential with respect to ground	$\pm 5 \text{ V}$
TE on "A" side of the interface originates signals to network on M lead	-56.5 V, no positive potential with respect to ground	$\pm 5 \text{ V}$	$\pm 5 \text{ V}$	$\pm 5 \text{ V}$

4.4.1.3.4 The maximum ac potential to ground shall not exceed $5 V_P$ on the following leads, from sources in the terminal equipment:

- a) M, SG and SB leads for terminal equipment on the "A" side of the interface.
- b) E, SG and M leads for terminal equipment on the "B" side of the inter-face.

4.4.1.3.5 If the approved terminal equipment contains an inductive component in the (E) or (M) lead, it shall assure that the transient voltage across the contact as a result of a relay contact opening does not exceed the following voltage and duration limitations:

- a) $300 V_P$,
- b) A rate of change of one V / μs , and
- c) A 60 V level after 20 ms.

4.4.1.4 Off premises station voltages

4.4.1.4.1 Talking battery or voltages applied by the PBX (or similar systems) to all classes of OPS interface leads for supervisory purposes shall be negative with respect to ground, shall not be more than -56.5 V dc with respect to ground, and shall not have a significant ac component. The ac component shall not exceed $5 V_P$, unless otherwise controlled by section 4.5.

4.4.1.4.2 Ringing signals applied by the PBX (or similar systems) to all classes of OPS interface leads shall comply with requirements in section 4.4.4. Ringing voltages shall be applied between the ring conductor and ground.

4.4.1.5 Direct Inward Dialing (DID). Voltages applied by the PBX (or similar systems) to DID interface leads for supervisory purposes shall be negative with respect to ground, shall not be more than -56.5 V dc with respect to ground, and shall not have a significant ac component. The ac component shall not exceed $5 V_P$, where

not otherwise controlled by section 4.5.

- 4.4.1.6 Local Area Data Channel Interfaces. For Local Area Data Channel interfaces, during normal operating modes including terminal equipment initiated maintenance signals, approved terminal equipment shall ensure, except during the application of ringing (limitations specified in section 4.4.4), with respect to telephone connections (tip, ring, tip-1, ring-1) that:
- 4.4.1.6.1 Under normal operating conditions, the rms current per conductor between short-circuit conductors, including dc and ac components, does not exceed 350 mA. For other than normal operating conditions, the rms current between any conductor and ground or between short-circuited conductors, including dc and ac components, may exceed 350 mA for no more than 1.5 minutes;
- 4.4.1.6.2 The dc voltage between any conductor and ground does not exceed 60 V. Under normal operating conditions it shall not be positive with respect to ground (though positive voltages up to 60 V may be allowed during brief maintenance states);
- 4.4.1.6.3 AC voltages are less than $42.4 V_P$ between any conductor and ground. Terminal equipment shall comply while other interface leads are:
- a) Un-terminated, and
 - b) Individually terminated to ground
- Combined ac and dc voltages between any conductor and ground shall be: less than $42.4 V_P$ when the absolute value of the dc component is less than 21.2 V; and less than $(32.8 + 0.454 \times V_{dc})$ when the absolute value of the dc component is between 21.2 and 60 V.
- 4.4.1.7 Ringdown Voiceband Private Line and Voiceband Metallic Channel Interface. During normal operation, approved terminal equipment for connection to ringdown voiceband private line interfaces or voiceband metallic channel interfaces shall ensure that:
- 4.4.1.7.1 Ringing voltage shall not exceed the voltage and current limits specified in section 4.4.4, and is:
- a) Applied to the ring conductor with the tip conductor grounded for 2-wire interfaces, or
 - b) Simplex on the tip and ring conductors with ground simplex on the tip-1 and ring-1 conductors for 4-wire interfaces.

- 4.4.1.7.2 Except during the signaling mode or for monitoring voltage, there shall be no significant positive dc voltage (not over +5 V) with respect to ground:
- a) For 2-wire ports between the tip lead and ground and the ring lead and ground and
 - b) For 4-wire ports between the tip lead and ground, the ring lead and ground, the tip-1 lead and ground, and the ring-1 lead and ground.
- 4.4.1.7.3 The dc current per lead, under short circuit conditions shall not exceed 140 mA.
- 4.4.2 Connection of non-approved equipment to approved terminal equipment or approved protective circuitry. Leads to, or any elements having a conducting path to telephone connections, auxiliary leads or E&M leads shall:
- a) Be reasonably physically separated and restrained from and be neither routed in the same cable as nor use the same connector as leads or metallic paths connecting power connections;
 - b) Be reasonably physically separated and restrained from and be neither routed in the same cable as nor use adjacent pins on the same connector as metallic paths that lead to non-approved equipment, when interface voltages are less than non-hazardous voltage source limits in section 4.4.3.

- 4.4.3 Non-Hazardous voltage Source: A voltage source shall be considered a non-hazardous voltage source if it conforms with the requirements of sections 4.2, 4.3 and 4.4.2, with all connections to the source other than primary power connections treated as “telephone connections,” and if such source supplies voltages no greater than the following under all modes of operation and of failure:
- a) AC voltages less than 42.4 V_P;
 - b) DC voltages less than 60 V; and
 - c) Combined ac and dc voltages between any conductor and ground are less than 42.4 V_P when the absolute value of the dc component is less than 21.2 V, and less than (32.8 + 0.454 x V dc) when the absolute value of the dc component is between 21.2 and 60 V.
- 4.4.4 Ringing Sources: Ringing sources shall meet all of the following restrictions:
- 4.4.4.1 Ringing Signal Frequency. The ringing signal shall use only frequencies whose fundamental component is equal to or below 70 Hz.
- 4.4.4.2 Ringing Signal voltage. The ringing voltage shall be less than 300 V_{P-P} and less than 200 V peak-to-ground across a resistive termination of at least 1 MΩ.
- 4.4.4.3 Ringing Signal Interruption Rate. The ringing voltage shall be interrupted to create quiet intervals of at least one second (continuous) duration each separated by no more than 5 seconds. During the quiet intervals, the voltage to ground shall not exceed the voltage limits given in section 4.4.1.4.1.
- 4.4.4.4 Ringing Signal Sources: Ringing voltage sources shall comply with the following requirements:
- a) If the ringing current through a 500 Ω (and greater) resistor does not exceed 100 mA_{P-P}, neither a ring trip device nor a monitoring voltage is required.
 - b) If the ringing current through a 1500 Ω (and greater) resistor exceeds 100 mA_{P-P}, the ringing source shall include a current-sensitive ring trip device in series with the ring lead that will trip ringing as specified in Figure 4.4 in accordance with the following conditions:
 - 1) If the ring trip device operates as specified in Figure 4.4 with R = 500 Ω (and greater), no monitoring voltage is required;
 - 2) If, however, the ring trip device only operates as specified in Figure 4.4 with R = 1500 Ω (and greater) then the ringing voltage source shall also provide a monitoring voltage between 19 V dc and 56.5 V dc, negative with respect to ground, on the tip or ring conductor.

- c) If the ringing current through a 500 Ω (and greater) resistor exceeds 100 mA_{P-P} but does not exceed 100 mA_{P-P} with 1500 Ω (and greater) termination, the ringing voltage source shall include either a ring trip device that meets the operating characteristics specified in Figure 4.4 with 500 Ω (and greater) resistor, or a monitoring voltage as specified in section 4.4.4.4 (b). If the operating characteristics specified in section 4.4 are not met with both the 500 Ω and 1500 Ω terminations, then the terminal equipment under test fails (See Table 4.4).

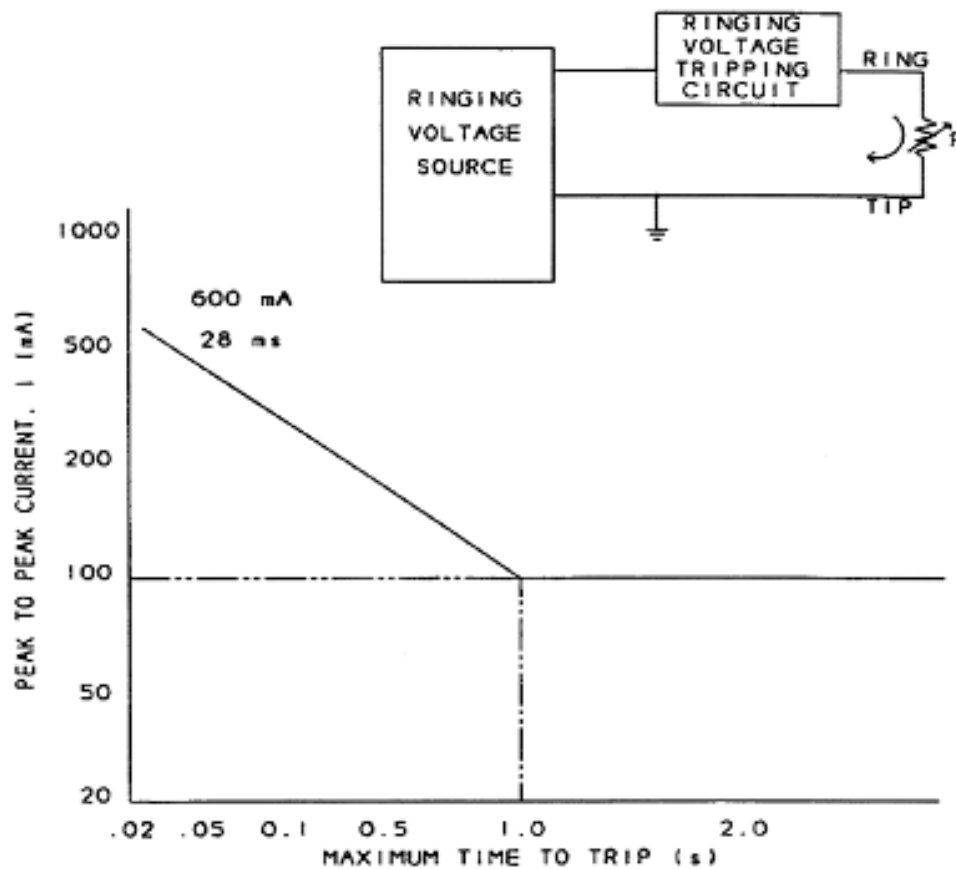

Figure 4.4 Ringing Voltage Trip Criteria

Table 4.4 Table Summary of Ring-Trip Requirements

4.4.4.4	Ringing Current (mA P-P)		Function Required		Ring-Trip Device Operates per Figure 4.4
	R = 500 Ω and greater	R = 1500 Ω and greater	Ring-Trip	Monitor voltage	
4.4.4.4(a)	<100	<100	Optional	Optional	Optional
4.4.4.4(b)(1)	N/A	>100	Yes	Optional	Yes for both resistances
4.4.4.4(b)(2)	N/A	>100	Yes	Yes	Yes for R = 1500 Ω and greater No for R = 500 Ω and greater
4.4.4.4(c)	>100	<100	Either Ring-Trip device or Monitor voltage shall be provided		Yes for R = 500 Ω and greater, if Ring-Trip device is used

4.4.5 Intentional paths to ground (as required by section 4.2)

4.4.5.1 Connections with operational paths to ground: Approved terminal equipment and approved protective circuitry having an intentional dc conducting path to earth ground at operational voltages that was excluded during the leakage current test of section 4.3 shall have a dc current source applied between the following points:

- a) Telephone connections, including tip, ring, tip-1, ring-1, E&M leads and auxiliary leads
- b) Earth grounding connections

For each test point, the current shall be gradually increased from zero to 1 A, then maintained for one minute. The voltage between (a) and (b) shall not exceed 0.1 V at any time. In the event there is a component or circuit in the path to ground, the requirement shall be met between the grounded side of the component or circuit and the earth grounding connection.

4.4.5.2 Connections with protection paths to ground. Approved terminal equipment and protective circuitry having an intentional dc conducting path to earth ground for protection purposes at the leakage current test voltage that was removed during the leakage current test of section 4.3 shall, upon its replacement, have a 50 or 60 Hz voltage source applied between the following points:

- a) Simplex telephone connections, including tip and ring, tip-1 and ring-1, E&M leads and auxiliary leads, and;
- b) Earth grounding connections.

The voltage shall be gradually increased from zero to 120 V rms for approved terminal equipment, or 300 V rms for protective circuitry, then maintained for one minute. The current between (a) and (b) shall not exceed 10 mA_P at any time. As an alternative to carrying out this test on the complete equipment or device, the test may be carried out separately on components, subassemblies, and simulated circuits, outside the unit, provided that the test results would be representative of the results of testing the complete unit.

4.5 SIGNAL POWER LIMITATIONS

4.5.1 General: Limits on signal power shall be met at the interface for all 2-wire network ports and, where applicable to offered services, both transmit and receive pairs of all 4-wire network ports. Signal power measurements shall be made using terminations as specified in each of the following limitations. The transmit and receive pairs for 4-wire network ports shall be measured with the pair not under test connected to a termination equivalent to that specified for the pair under test. Through gain limitations shall apply only in the direction of transmission toward the network.

4.5.2 Voiceband metallic signal power

4.5.2.1 Limitations at the interface on internal signal sources not intended for network control signaling:

4.5.2.1.1 The power of all signal energy other than live voice, in the 200–3995 Hz voiceband, delivered by approved terminal equipment or approved protective circuitry to the appropriate loop simulator — other than non-permissive data equipment or data protective circuitry shall not exceed -9 dBm when averaged over any 3-second interval.

4.5.2.1.2 For 2-wire and 4-wire lossless tie trunk type interfaces, the maximum power of other than live voice signals delivered to a 600 Ω termination shall not exceed -15 dBm when averaged over any 3-second interval.

4.5.2.1.3 For OPS lines, the maximum power of other than live voice delivered to an OPS line simulator circuit shall not exceed -9 dBm, when averaged over any 3-second interval.

- 4.5.2.1.4 For approved test equipment or approved test circuitry the maximum signal power delivered to a loop simulator circuit shall not exceed 0 dBm when averaged over any 3-second interval.
- 4.5.2.1.5 For voiceband private lines using ringdown or inband signaling the maximum power of other than live voice signals delivered to a 600 Ω termination shall not exceed -13 dBm when averaged over any 3-second interval.
- 4.5.2.1.6 For voiceband private lines using inband signaling in the band 2600 \pm 150 Hz, the maximum power delivered to a 600 Ω termination shall not exceed -8 dBm during the signaling mode. The maximum power delivered to a 600 Ω termination in the on-hook steady state supervisory condition shall not exceed -20 dBm. The maximum power of other than live voice signals delivered to a 600 Ω termination during the non-signaling mode and for other inband systems shall not exceed -13 dBm when averaged over any 3-second interval.
- 4.5.2.2 Limitations on internal signal sources primarily intended for network control signaling, contained in voice and data equipment.
 - 4.5.2.2.1 For all operating conditions of approved terminal equipment and approved protective circuitry, the maximum power in the frequency band below 3995 Hz delivered to a loop simulator circuit shall not exceed the following when averaged over any 3-second interval:
 - a) 0 dBm when used for network control (DTMF);
 - b) 0 dBm when DTMF is used for manual entry end-to-end signaling. When the device is used for this purpose it shall not generate more than 40 DTMF digits per manual key stroke;
 - c) -9 dBm in all other cases.
 - 4.5.2.2.2 For tie trunk applications, the maximum power delivered to a 600 Ω termination for approved terminal equipment and approved protective circuitry under all operating conditions shall not exceed -4 dBm over any 3-second interval.
- 4.5.2.3 Approved one-port and multiport terminal equipment and protective circuitry with provision for through transmission from other terminal equipment, excluding data equipment and data protective circuitry that are approved in accordance with section 4.5.
 - 4.5.2.3.1 Where through-transmission equipment provides a dc electrical signal to equipment connected therewith (e.g. for powering of electro-acoustic transducers), dc conditions shall be provided which fall within the range of conditions provided by a loop simulator circuit unless the combination of the through-transmission equipment and equipment connected therewith is approved as a combination which conforms to sections 4.5.2 and 4.5.2.2.
 - 4.5.2.3.2 Through-transmission equipment to which remotely connected data terminal equipment may be connected shall not be equipped with or connected to either a Universal or Programmed Data Jack used in data configurations. (See section

4.5.2.4.)

- 4.5.2.4 Approved data circuit terminal equipment shall be capable of operation in at least one of the states discussed in sections 4.5.2.1, and 4.5.2.1.2, and 4.5.2.1.3. The output power level of the data circuit terminal equipment shall not be alterable, by the customer, to levels that exceed the signal power limits specified herein.
- 4.5.2.4.1 Data circuit terminal equipment intended to operate with a programming resistor for signal level control shall not exceed the programmed levels given in Table 4.5.
- 4.5.2.4.2 Data circuit terminal equipment intended to operate in the fixed loss loop (FLL) state shall not transmit signal power that exceeds -4 dBm, in the 200-3995 Hz voiceband, when averaged over any and all 3-second intervals.
- 4.5.2.4.3 Data circuit terminal equipment shall not transmit signals from 200 to 3995 Hz that exceed -9 dBm, when averaged over any and all 3-second intervals.

Table 4.5 Programming Resistors

Programming Resistor R_P^* (Ω)	Programmed Data Equipment Signal power output
Short	0 dBm
150	-1 dBm
336	-2 dBm
569	-3 dBm
866	-4 dBm
1240	-5 dBm
1780	-6 dBm
2520	-7 dBm
3610	-8 dBm
5490	-9 dBm
9200	-10 dBm
19800	-11 dBm
Open	-12 dBm

*Tolerance 1%

- 4.5.2.5 Approved one-port and multi-port terminal equipment and protective circuitry with provision for transmission from ports to other equipment that is separately approved for the public switched network, or ports to other network interfaces.
- 4.5.2.5.1 Approved terminal equipment and approved protective circuitry shall have no adjustments that will allow net amplification to occur in either direction of transmission in the through-transmission path within the 200–3995 Hz voiceband that will exceed the following:

Table 4.6 Allowable Net Amplification Between Ports (See notes 1, 3, 4, and 5)

To	Tie Trunk Type Ports			Integrated	OPS Ports	Public	HCC
	2/4-wire	Sub-rate 1.544 Mbps Satellite 4W	Sub-rate 1.544 Mbps Tandem4 W				
From (see note 5)				Services Trunk	(2-wire) (2)	Switched Network Ports (2-wire)	Digital PBX-CO 4-wire
2/4 wire tie	0 dB	3 dB	3 dB	3 dB	6 dB		
Sub-rate 1.544 Mbps Satellite 4W Tie	0 dB		3 dB	3 dB	6 dB		
Sub-rate 1.544 Mbps Tandem 4W Tie	-3 dB	0 dB	0 dB	0 dB	3 dB		
Integrated Services Trunk	-3 dB	0 dB	0 dB	0 dB	3 dB		
RTE Digital	0 dB	0 dB	0 dB	0 dB	3 dB	3 dB	0 dB
RTE (see note 2) PSTN/ OPS	-3 dB	-3 dB	-3 dB	-3 dB	0 dB	0 dB	-3 dB
OPS (see note 2)	-2 dB	1 dB	1 dB	1 dB	4 dB	4 dB	1 dB
Public Switched Network (2-wire)					3 dB	3 dB	
HCC Digital PBX-CO (4-wire)					3 dB		

NOTES:

- 1) The source impedance for all measurements shall be 600 Ω. All ports shall be terminated in appropriate loop or private line channel simulator circuits or 600 Ω terminations.
- 2) These ports shall be for 2-wire on-premises station ports to separately approved terminal equipment.
- 3) These through gain limitations shall be applicable to multiport systems where channels are not derived by time or frequency compression methods. Terminal equipment employing such compression techniques shall assure that equivalent compensation for through gain parameters shall be demonstrated.
- 4) Approved terminal equipment and approved protective circuitry may have net amplification exceeding the limitations of section 4.5.2.5.1

provided that, for each network interface type to be connected, the absolute signal power levels specified in section 4.5 are not exceeded.

- 5) The indicated gain shall be in the direction that results when moving from the horizontal entry toward the vertical entry.
- 6) Approved terminal equipment or protective circuitry with the capability for through transmission from voiceband private line channels or voiceband metallic channels to other telephone network interfaces shall ensure that the absolute signal power levels specified in section 4.5, for each telephone network interface type to be connected, are not exceeded.
- 7) Approved terminal equipment or protective circuitry with the capability for through transmission from voiceband private line channels or voiceband metallic private line channels to other telephone network interfaces shall assure, for each telephone network interface type to be connected, that signals with energy in the 2450 to 2750 Hz band are not through transmitted unless there is at least an equal amount of energy in the 800 to 2450 Hz band within 20 ms of application of signal.

4.5.2.5.2 The insertion loss in through connection paths for any frequency in the 800 to 2450 Hz band shall not exceed the loss at any frequency in the 2450 to 2750 Hz band by more than 1 dB (maximum loss in the 800 to 2450 Hz band minus minimum loss in the 2450 to 2750 Hz band plus 1 dB).

4.5.2.6 For Tie Trunk Interfaces – Limitation on idle circuit stability parameters: For idle state operating conditions of approved terminal equipment and approved protective circuitry, the following limitations shall be met:

4.5.2.6.1 For the two-wire interface:

$$RL \geq \begin{cases} 9 - 3 \frac{\log(f/200)}{\log(2.5)} \text{ dB} & ; \text{ for } 200 \text{ Hz} \leq f \leq 500 \text{ Hz} \\ 6 \text{ dB} & ; \text{ for } 500 \text{ Hz} \leq f \leq 3200 \text{ Hz} \end{cases}$$

4.5.2.6.2 For the four-wire lossless interface:

$$\begin{aligned}
 tl_f &\geq \begin{cases} 10 - 4 \frac{\log(f/200)}{\log(2.5)} \text{ dB} & ; \text{ for } 200 \text{ Hz} \leq f \leq 500 \text{ Hz} \\ 6 \text{ dB} & ; \text{ for } 500 \text{ Hz} \leq f \leq 3200 \text{ Hz} \end{cases} \\
 tl_r &> 40 \text{ dB} \\
 RL_i, RL_o &\geq 3 \text{ dB}
 \end{aligned}$$

4.5.2.6.3 The following definitions shall apply to return loss requirements:

- a) RL the return loss of 2-wire terminal equipment at the interface with respect to $600 \Omega + 2.16 \mu\text{F}$ (i.e., $Z_{ref} = 600 \Omega + 2.16 \mu\text{F}$).

$$RL \triangleq 20 \log_{10} \left| \frac{Z_{PBX} + Z_{ref}}{Z_{PBX} - Z_{ref}} \right|$$

- b) RL_i the terminal equipment input (receive) port return loss with respect to 600Ω (i.e., $Z_{ref} = 600 \Omega$).

$$RL_i \triangleq \log_{10} \left| \frac{Z_{PBX (input)} + Z_{ref}}{Z_{PBX (input)} - Z_{ref}} \right|$$

- c) RL_o the terminal equipment output (transmit) port return loss with respect to 600Ω (i.e., $Z_{ref} = 600 \Omega$).

$$RL_o \triangleq 20 \log_{10} \left| \frac{Z_{PBX (output)} + Z_{ref}}{Z_{PBX (output)} - Z_{ref}} \right|$$

- d) tl the transducer loss between the receive and transmit ports of the 4-wire PBX.

$$tl_f \triangleq 20 \log_{10} \left| \frac{I_i}{I_r} \right|$$

- e) tl_f is the transducer loss in the forward direction from the receive port to the transmit port of the PBX.
- f) Where I_i is the current sent into the receive port and I_r is the current received at the transmit port terminated at 600 Ω .
- g) tl_r is the transducer loss in the reverse direction, from the transmit port to the receive port of the PBX.

$$tl_r \triangleq 20 \log_{10} \left| \frac{I_i}{I_r} \right|$$

- h) Where I_i is the current sent into the transmit port and I_r is the current received at the receive port terminated at 600 Ω . The source impedance of I_i shall be 600 Ω .

4.5.2.7 Approved terminal equipment and approved protective circuitry shall provide the following range of dc conditions to off-premises station (OPS) lines.

4.5.2.7.1 DC voltages applied to the OPS interface for supervisory purposes and during network control signaling shall meet the limits specified in section 4.4.1.4.1.

4.5.2.7.2 DC voltages applied to the OPS interface during the talking state shall meet the following requirements:

4.5.2.7.2.1 The maximum open circuit voltage across the tip (T(OPS)) and ring (R(OPS)) leads for all classes shall not exceed 56.5 V, and

4.5.2.7.2.2 Except for class A OPS interfaces, the maximum dc current into a short circuit across tip (T(OPS)) and ring (R(OPS)) leads shall not exceed 140 mA.

4.5.2.7.2.3 Except for Class A OPS interfaces, the dc current into the OPS line simulator circuit shall be at least 20 mA for the following conditions (see Figure 1.7)

Condition	$R_2 + R_L$	
	Class B	Class C
1	600	1300
2	1800	2500

4.5.3 Signal power in the 3995–4005 Hz frequency band

4.5.3.1 Power resulting from internal signal sources contained in approved protective circuitry and approved terminal equipment (voice and data), not intended for network control signaling: For all operating conditions of approved terminal equipment and approved protective circuitry that incorporate signal sources other than sources intended for network control signaling, the maximum power delivered by such sources in the 3995–4005 Hz band to an appropriate simulator circuit, shall be 18 dB below maximum permitted power specified in section 4.5.2 for the voiceband.

4.5.3.2 Terminal equipment with provision of through-transmission from other equipment: The loss in any through-transmission path of approved terminal equipment and approved protective circuitry at any frequency in the 600 to 4000 Hz band shall not exceed, by more than 3 dB, the loss at any frequency in the 3995 to 4005 Hz band, when measured into an appropriate simulator circuit from a source that appears as 600 Ω across tip and ring.

4.5.4 Longitudinal voltage at frequencies below 4 kHz

4.5.4.1 The weighted rms voltage (see note) averaged over 100 ms that is resultant of all of the component longitudinal voltages in the 100 Hz to 4 kHz band after weighting according to the transfer function of $f/4000$ where f is the frequency in Hz, shall not exceed the maximum indicated under the conditions stated in section 4.5.7.

NOTE: Average magnitudes may be used for signals that have peak-to-rms ratios of 20 dB and less. The rms limitations shall be used instead of average values if the peak-to-rms ratio of the interfering signal exceeds this value.

Frequency range	Maximum weighted rms voltage	Impedance
100 Hz to 4 kHz	-30 dBV	500 Ω

4.5.5 Voltage in the 4 kHz to 30 MHz frequency range-general case –2-wire and 4-wire lossless interface (except LADC).

Except as noted, rms voltage as averaged over 100 ms at the telephone connections of approved terminal equipment and approved protective circuitry in all of the possible 8-kHz bands within the indicated frequency range and under the conditions specified in section 4.5.7 shall not exceed the maximum indicated below. For sections 4.5.5.1.1 and 4.5.5.2.1, “f” shall be the center frequency in kHz of each of the possible 8-kHz bands beginning at 8 kHz.

4.5.5.1 Metallic voltage.

4.5.5.1.1 4 kHz to 270 kHz:

Center frequency (f) of 8-kHz band	Max voltage in all 8-kHz bands	Metallic terminating impedance
8 kHz to 12 kHz	$-(6.4 + 12.6 \log f)$ dBV	300 Ω
12 kHz to 90 kHz	$(23 - 40 \log f)$ dBV	135 Ω
90 kHz to 266 kHz	-55 dBV	135 Ω

4.5.5.1.2 270 kHz to 30 MHz. The rms value of the metallic voltage components in the frequency range of 270 kHz to 30 MHz shall, averaged over 2 μ s, not exceed -15 dBV. This limitation applies with a metallic termination having an impedance of 135 Ω .¹

4.5.5.2 Longitudinal voltage

4.5.5.2.1 4 kHz to 270 kHz.

Center frequency (f) of 8-kHz band	Max voltage in all 8-kHz bands	Longitudinal terminating impedance
8 kHz to 12 kHz	$-(18.4 + 20 \log f)$ dBV	500 Ω
12 kHz to 42 kHz	$(3 - 40 \log f)$ dBV	90 Ω
42 kHz to 266 kHz	-62 dBV	90 Ω

¹ A filter between the TE and the network interface may be necessary to meet this requirement.

4.5.5.2.2 270 kHz to 6 MHz. The rms value of the longitudinal voltage components, in the frequency range of 270 kHz to 6 MHz shall not exceed -30 dBV with a longitudinal termination having an impedance of 90 Ω.

4.5.6 LADC interface

The metallic voltage shall comply with the general requirements in section 4.5.6.1 as well as the additional requirements specified in sections 4.5.6.2 and 4.5.6.3. The requirements apply under the conditions specified in section 4.5.7. Terminal equipment for which the magnitude of the source and/or terminating impedance exceeds 300 Ω, at any frequency in the range of 100 kHz to 6 MHz, at which the signal (transmitted and/or received) has significant power, shall be deemed not to comply with these requirements. A signal shall be considered to have “significant power” at a given frequency if that frequency is contained in a designated set of frequency bands that collectively have the property that the rms voltage of the signal components in those bands is at least 90% of the rms voltage of the total signal. The designated set of frequency bands shall be used in testing all frequencies.

4.5.6.1 Metallic voltages—frequencies below 4 kHz

4.5.6.1.1 Weighted rms voltage in the 10 Hz to 4 kHz frequency band. The weighted rms metallic voltage in the frequency band from 10 Hz to 4 kHz, averaged over 100 ms that is the resultant of all the component metallic voltages in the band after weighting according to the transfer function of $f/4000$ where f is the frequency in Hz, shall not exceed the maximum indicated below under the conditions stated in section 4.5.7.

Frequency Range	Maximum voltage
10 Hz to 4 kHz	+3 dBV

4.5.6.1.2 RMS voltage in 100 Hz bands in the frequency range 0.7 kHz to 4 kHz. The rms metallic voltage averaged over 100 ms in the 100-Hz bands having center frequencies between 750 Hz and 3950 Hz shall not exceed the maximum indicated below.

Center freq (f) of 100-Hz bands	Max voltage in all 100-Hz bands
750 to 3950 Hz	-6 dBV

4.5.6.2

Metallic voltages—frequencies above 4 kHz—LADC interface

- 4.5.6.2.1 100-Hz bands over frequency range of 4 kHz to 270 kHz. The rms voltage as averaged over 100 ms in all possible 100-Hz bands between 4 kHz and 270 kHz for the indicated range of center frequencies and under the conditions specified in section 4.5.7 shall not exceed the maximum indicated below:

Center freq (f) of all 100-Hz bands	Max voltage in all 100-Hz bands
4.05 kHz to 4.6 kHz	0.5 dBV
4.60 kHz to 5.45 kHz	(59.2-90 log f) dBV
5.45 kHz to 59.12 kHz	(7.6-20 log f) dBV
59.12 kHz to 266.00 kHz	(43.1-40 log f) dBV

Where f = center frequency in kHz of each of the possible 100-Hz bands.

- 4.5.6.2.2 8-kHz bands over frequency range of 4 kHz to 270 kHz. The rms voltage as averaged over 100 ms in all of the possible 8-kHz bands between 4 kHz and 270 kHz for the indicated range of center frequencies and under the conditions specified in section 4.5.7 shall not exceed the maximum indicated below:

Center freq (f) of 8-kHz bands	Max voltage in all 8-kHz bands
8 kHz to 120 kHz	(17.6—20 log f) dBV
120 kHz to 266 kHz	(59.2—40 log f) dBV

Where f = center frequency in kHz of each of the possible 8-kHz bands

- 4.5.6.2.3 RMS voltage at frequencies above 270 kHz. The rms value of the metallic voltage components in the frequency range of 270 kHz to 30 MHz, averaged over 2 μ s, shall not exceed -15 dBV with a metallic termination having an impedance of 135 Ω .

- 4.5.6.2.4 Peak voltage. The total peak voltage for all frequency components in the 4-kHz to 6-MHz band shall not exceed 4.0 V.

- 4.5.6.3 Longitudinal voltage.

4.5.6.3.1 Frequencies below 4 kHz. The weighted rms voltage in the frequency band from 10 Hz to 4 kHz, averaged over 100 ms is the resultant of all the component longitudinal voltages in the band after weighting according to the transfer function of $f/4000$, where f is the frequency in Hz. The resultant weighted rms voltage shall not exceed the maximum indicated below under the conditions stated in section 4.5.7.

Frequency Range	Maximum RMS voltage
10 Hz to 4 kHz	-37 dBV

4.5.6.3.2 4 kHz to 270 kHz.

Center freq (f) of 8-kHz bands	Max voltage in all 8-kHz bands	Longitudinal terminating impedance
8 to 12 kHz	$-(18.4+20 \log f)$ dBV	500 Ω
12 to 42 kHz	$(3-40 \log f)$ dBV	90 Ω
42 to 266 kHz	-62 dBV	90 Ω .

Where f = center frequency in kHz of each of the possible 8-kHz bands.

4.5.6.3.3 270 kHz to 6 MHz. The rms value of the longitudinal voltage components in the frequency range of 270 kHz to 6 MHz, averaged over 2 ms, shall not exceed -30 dBV with a longitudinal termination having an impedance of 90 Ω .

4.5.7 Requirements in sections 4.5.4, 4.5.5 and 4.5.6 shall apply under the following conditions:

4.5.7.1 All approved terminal equipment, except equipment to be used on LADC, and all approved protective circuitry, shall comply with the limitations when connected to a termination equivalent to the circuit depicted in Figure 4.5 and when placed in all operating states of the equipment except during network control signaling. LADC approved terminal equipment shall comply with the metallic voltage limitations when connected to circuits of Figure 1.10 and shall comply with the longitudinal limitations when connected to circuits of Figure 4.5, as indicated.

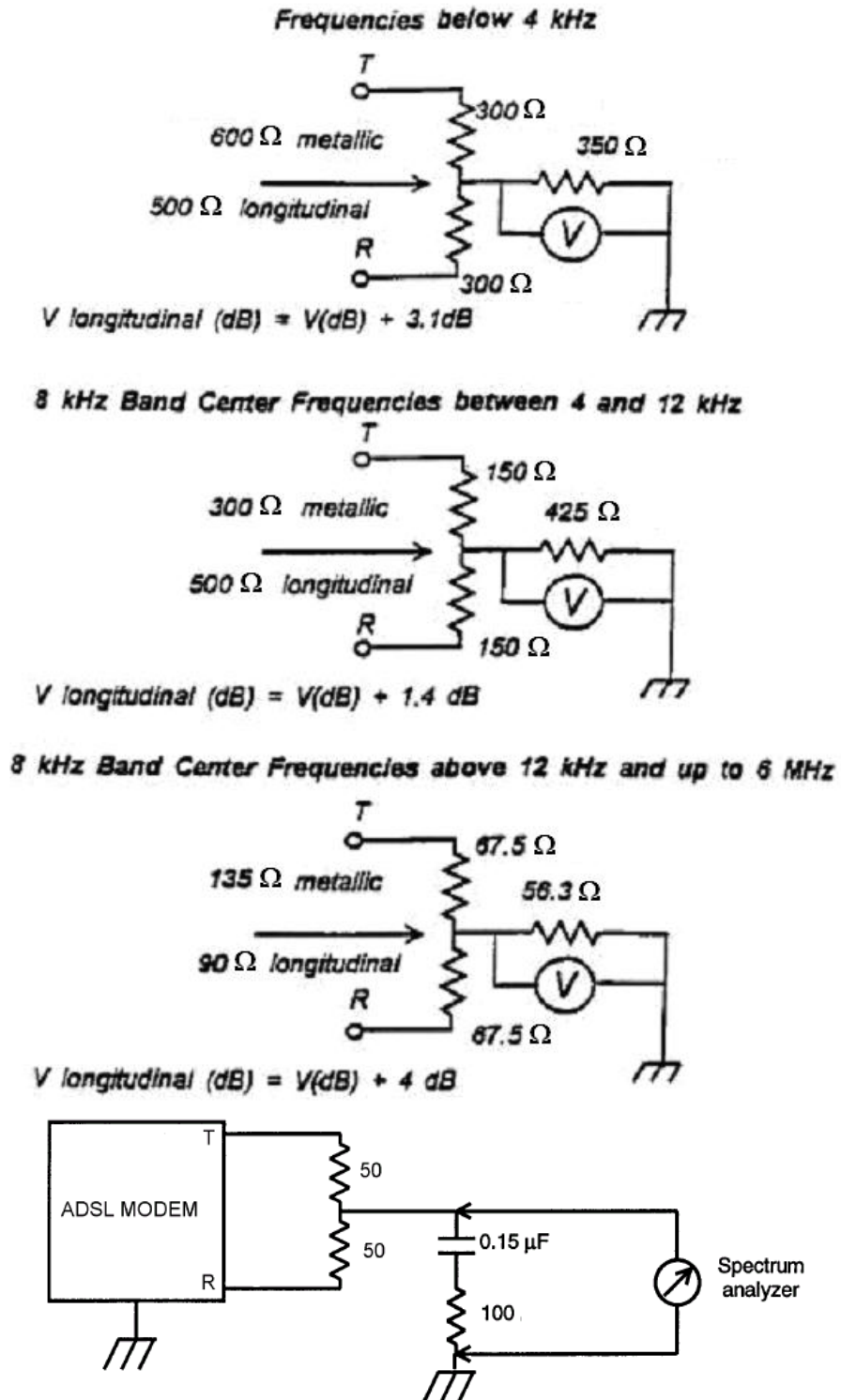

Figure 4.5 Resistive Terminations

Note: All resistor values are in ohms.

- 4.5.7.2 All approved terminal equipment and approved protective circuitry shall comply with the limitations in the off-hook state over the range of loop currents that would flow with the equipment connected to an appropriate simulator circuit.
- 4.5.7.3 Approved terminal equipment and approved protective circuitry with provision for through-transmission from other equipments shall comply with the limitations with a 1000 Hz tone applied from a 600 Ω source (or, if appropriate a source which reflects a 600 Ω impedance across tip and ring) at the maximum level that would be applied during normal operation. Approved protective circuitry for data shall also comply with the tone level 10 dB higher than the overload point.
- 4.5.7.4 For approved terminal equipment or approved protective circuitry with non-approved signal source input, such as music on hold, the out of band signal power requirements shall be met using an input signal with a frequency range of 200 Hz to 20 kHz and the level set at the overload point.
- 4.5.7.5 Except during the transmission of ringing (section 4.4.4) and Dual Tone Multi-frequency (DTMF) signals, LADC approved terminal equipment shall comply with all requirements in all operating states and with loop current that may be drawn for such purposes as loop back signaling. The requirements in section 4.5.6.1 except in 4.5.6.1.1 and 4.5.6.1.2 shall also apply during the application of ringing. The requirement in 4.5.4 and the requirements in 4.5.6.1.1 and 4.5.6.1.2 shall apply during ringing for frequencies above 300 Hz and with the maximum voltage limits raised by 10 dB. DTMF signals which are used for the transmission of alphanumeric information and which comply with the requirements in 4.5.6.1.1, and in 4.5.6.2 or 4.5.6.3 as applicable, shall be deemed to comply with the requirements in 4.5.6.1.2 provided that, for automatically originated DTMF signals, the duty cycle is less than 50%.
- 4.5.7.6 LADC approved terminal equipment shall comply with all applicable requirements, except those specified in sections 4.5.6.1.1 and 4.5.6.1.2, during the transmission of each possible data signal sequence of any length. For compliance with 4.5.6.3.1, the limitation applies to the rms voltage averaged as follows:
- a) For digital signals, baseband or modulated on a carrier, for which there are defined signal element intervals, the rms voltage shall be averaged over each such interval. Where multiple carriers are involved, the voltage is defined as the power sum of the rms voltages for the signal element intervals for each carrier.
 - b) For baseband analog signals, the rms voltage shall be averaged over each period (cycle) of the highest frequency of the signal (-3 dB point on the spectrum). For analog signals that are modulated on a carrier (whether or not the carrier is suppressed), it shall be averaged over each period (cycle) of the carrier. Where multiple carriers are involved, the voltage is defined as the power sum of the rms voltage for each carrier.
 - c) For signals other than the types defined in section 4.5.7.6(a) and 4.5.7.6(b) and (1) above, the peak amplitude of the signal shall not exceed +1 dBV.
- 4.5.7.7 Equipment shall comply with the requirements in section 4.5.6.1.1 and 4.5.6.1.2,

during any data sequence that may be transmitted during normal use with a probability greater than 0.001. If the sequences transmitted by the equipment are application dependent, the user instruction material shall include a statement of any limitations assumed in demonstrating compliance of the equipment.

4.5.7.8 In addition to the conditions specified in section 4.5.7.5, LADC approved terminal equipment which operates in one or more modes as a receiver, shall comply with requirements in 4.5.6.3 with a tone at all frequencies in the range of potential received signals and at the maximum power which may be received.

4.5.8 Interference limitations for terminal equipment connecting to digital services

4.5.8.1 Limitations on Terminal Equipment Connecting to Subrate Digital Services

In addition to the requirements in 4.5.8.1.1 and 4.5.8.1.2, subrate TE shall meet either the PSD and average power requirements in 4.5.8.1.3 through 4.5.8.1.5 or the output pulse template and average power requirements in 4.5.8.1.6 and 4.5.8.1.7.

4.5.8.1.1 Pulse repetition rate. The pulse repetition rate shall be synchronous with 2.4, 3.2, 4.8, 6.4, 9.6, 12.8, 19.2, 25.6, 38.4, 56.0, or 72 kbps per second.

4.5.8.1.2 Encoded analog content.

If approved terminal equipment connecting to sub-rate services contains an analog-to-digital converter, or generates signals directly in digital form that are intended for eventual conversion into voiceband analog signals, the encoded analog content of the digital signal shall be limited as specified in Section 4.5.10.

4.5.8.1.3 Equivalent PSD for maximum output.

When applied to a 135 ohm resistor, the instantaneous amplitude of the PSD, obtainable from the registered terminal equipment, shall not exceed the PSD defined by the following limiting function, in dBm/Hz:

$$10 \cdot \log \left[\frac{(A^2) \frac{56000}{f_{\text{baud}}}}{\left[\left(\frac{f}{f_{3\text{dB}}} \right)^2 + 1 \right] \cdot \left[\left(\frac{f}{f_{\text{baud}} \cdot k} \right)^2 + 1 \right]} \right] - \text{Additional_Attenuation}$$

where “A” is equal to ½ for 9.6 kbps and 12.8 kbps or 1 for all other rates, “fbaud” is equal to the baud rate, “f3dB” is equal to 1.3 times the baud rate times 1.05, “f” is the frequency, and “k” is defined in Table 4.7. Additional attenuation is required at certain baud rates in the bands specified in Tables 4.8 and 4.9. PSD shall be measured for frequencies between ½ the baud rate and 20 times the baud rate. If 20 times the baud rate is less than 80 kHz, then the upper frequency measurement bound shall be 80 kHz. The resolution bandwidth for the PSD shall be less than or equal to 0.1 times the baud rate but no greater than 3 kHz.

4.5.8.1.4 Average Power for non-Secondary Channel Rates.

The average output power when a random signal sequence, (0) or (1) equiprobable

in each pulse interval, is being produced as measured across a 135 ohm resistance shall not exceed the values shown in Table 4.7.

4.5.8.1.5 Average Power for Secondary Channel Rates.

The customer data shall be a random signal sequence, (0) or (1) equiprobable in each pulse interval. The network control bit shall equal 1, and the framing pattern shall be (0) or (1) with equal probability. The average output power as measured across a 135 ohm resistance shall not exceed the values shown in Table 4.7.

4.5.8.1.6 Template for maximum output pulse.

When applied to a 135 Ω resistor, the instantaneous amplitude of the largest isolated output pulse obtainable from the approved terminal equipment shall not exceed by more than 10% the instantaneous voltage defined by a template obtained as follows: The limiting pulse template shall be determined by passing an ideal 50% duty cycle rectangular pulse with the amplitude/pulse rate characteristics defined in Table 4.7 through a single real pole low pass filter having a cutoff frequency in Hz equal to 1.3 times the bit rate. For bit rates of 2.4, 3.2, 4.8, 6.4, 9.6 and 12.8 kbps, the filtered pulses shall also be passed through a filter providing the additional attenuation in Table 4.8.

Table 4.7—Values for k and average output power

Line rate (kbps)	User data rate (R) (kbps)	Values for k	Maximum average power (dBm)
2.4	2.4	0.00727798	6.9
3.2	2.4 with SC ¹	0.00804454	7.4
4.8	4.8	0.00727798	6.9
6.4	4.8 with SC ¹	0.00804454	7.4
9.6	9.6	0.00727798	0.9
12.8	9.6 with SC ¹	0.00804454	1.4
19.2	19.2	0.00727798	6.9
25.6	19.2 with SC ¹	0.00804454	7.4
38.4	38.4	0.00727798	6.9
51.2	38.4 with SC ¹	0.00804454	7.4
56	56	0.00727798	6.9
72	56 with SC ¹	0.00795272	7.4
72	64	0.00727798	6.9

¹SC: Secondary Channel

Table 4.8 Driving Pulse Amplitude for Subrate Terminal Equipment

Line Rate (kbps)	User Data Rate (kbps)	Amplitude (V)
2.4	2.4	1.66
3.2	2.4 with SC *	1.66
4.8	4.8	1.66
6.4	4.8 with SC *	1.66
9.6	9.6	0.83
12.8	9.6 with SC *	0.83
19.2	19.2	1.66
25.6	19.2 with SC *	1.66
38.4	38.4	1.66
51.2	38.4 with SC *	1.66
56	56	1.66
72	56 with SC *	1.66
72	64	1.66

* SC: Secondary Channel.

Table 4.9 Minimum Additional Attenuation for Subrate Terminal Equipment

Line rate (R) (kbps)	Attenuation in frequency band 24–32 kHz (dB)	Attenuation in frequency band 72–80 kHz (dB)
2.4	5	1
3.2	5	1
4.8	13	9
6.4	13	9
9.6	17	8
12.8	17	8

The attenuation indicated may be reduced at any frequency within the band by the weighting curve of Table 4.9. Minimum rejection shall never be less than 0 dB; i.e., the weight shall not justify gain over the system without added attenuation.

Table 4.10 Attenuation Curve for Subrate Terminal Equipment

24–32 kHz band	72–80kHz band	Attenuation factor (dB)
24	72	-18
25	73	-3
26	74	-1
27	75	0
28	76	0
29	77	0
30	78	-1
31	79	-3
32	80	-18

4.5.8.1.7 Average power. The average output power when a random signal sequence, (0) or (1) equiprobable in each pulse interval, is being produced as measured across a 135 Ω resistance shall not exceed 0 dBm for 9.6 and 12.8 kbps or +6 dBm for all other rates shown in Table 4.7.

4.5.8.1.8 Encoded analog content. If approved terminal equipment connecting to sub-rate services contains an analog-to-digital converter, or generates signals directly in digital form that are intended for eventual conversion into voiceband analog signals, the encoded analog content of the digital signal shall be limited as specified in Section 4.5.10.

4.5.8.2 Limitations on Terminal Equipment Connecting to 1.544 Mbps Digital Services and ISDN PRA services.

4.5.8.2.1 Pulse repetition rate: The free running line rate of the transmit signal shall be 1.544 Mbps with a tolerance of ± 32 ppm, i.e., ± 50 bps.

4.5.8.2.2 Output pulse templates. The approved terminal equipment shall be capable of optionally delivering three sizes of output pulses. The output pulse option shall be selectable at the time of installation.

4.5.8.2.2.1 Option A output pulse. When applied to a 100 Ω resistor, the instantaneous amplitude of the largest output pulse obtainable from the approved terminal equipment shall fall within the pulse template illustrated in Figure 4.6. The mask may be positioned horizontally as needed to encompass the pulse, and the amplitude of the normalized mask may be uniformly scaled to encompass the pulse. The baseline of the mask shall coincide with the pulse baseline.

4.5.8.2.2.2 Option B output pulse. When applied to a 100 Ω resistor, the instantaneous

amplitude of the output from the approved terminal equipment obtained when Option B is implemented shall fall within the pulse template obtained by passing the bounding pulses permitted by Figure 4.6 through the following transfer function.

$$\frac{V_{out}}{V_{in}} = \frac{n_2 S^2 + n_1 S + n_0}{d_3 S^3 + d_2 S^2 + d_1 S + d_0}$$

where:

$$\begin{aligned} n_0 &= 1.6049 \times 10^6 \\ n_1 &= 7.9861 \times 10^{-1} \\ n_2 &= 9.2404 \times 10^{-8} \\ d_0 &= 2.1612 \times 10^6 \\ d_1 &= 1.7223 \\ d_2 &= 4.575 \times 10^{-7} \\ d_3 &= 3.8307 \times 10^{-14} \\ S &= j 2 \pi f \\ f &= \text{frequency (Hz)} \end{aligned}$$

4.5.8.2.2.3 Option C output pulse. When applied to a 100 Ω resistor, the instantaneous amplitude of the output from the approved terminal equipment obtained when Option C is implemented shall fall within the pulse template obtained by passing the pulses obtained in Option B through the transfer function in Option B a second time.

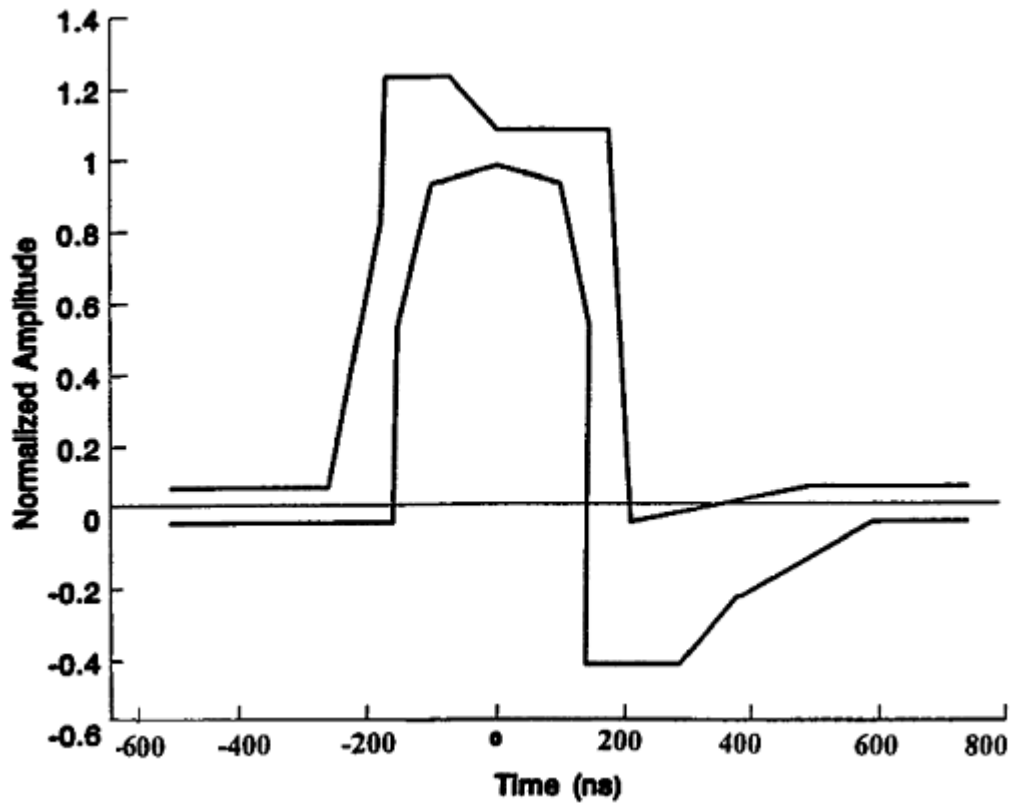

Maximum Curve

Nanoseconds (ns)	-500	-250	-175	-175	-75	0	175	220	500	750
Normalized amplitude	0.05	0.05	0.8	1.2	1.2	1.05	1.05	-0.05	0.05	0.05

Minimum Curve

Nanoseconds (ns)	-500	-150	-150	-100	0	100	150	150	300	396	600	750
Normalized amplitude	-0.05	-0.05	0.5	0.9	0.95	0.9	0.5	-0.45	-0.45	-0.26	-0.05	-0.05

The pulse amplitude shall be 2.4 to 3.6 V. (Use constant scaling factor to fit normalized template.)

Figure 4.6 Isolated Pulse Template And Corner Points For ISDN PRA and 1.544 Mbps Equipment

4.5.8.2.3 Adjustment of signal voltage

The signal voltage at the network interface shall be limited so that the range of pulse amplitudes received at the first telephone company repeater is controlled to ± 4 dB. This limitation shall be achieved by implementing the appropriate output pulse option as a function of telephone company cable loss as specified at time of installation.

Cable loss at 772 kHz (dB)	Terminal Equipment	
	Output pulse	Loss at 772 kHz
15 to 22	Option A	0
7.5 to 15	Option B	7.5
0 to 7.5	Option C	15

4.5.8.2.4 Output power.

The output power in a 3-kHz band about 772 kHz when an all ones signal sequence is being produced as measured across a 100 Ω terminating resistance shall not exceed +19 dBm. The power in a 3 kHz band about 1.544 MHz shall be at least 25 dB below that in a 3-kHz band about 772 kHz.

4.5.8.2.5 Encoded analog content.

If approved terminal equipment connected to 1.544 Mbps digital services or ISDN PRA services contains an analog-to-digital converter, or generates signals directly in digital form that are intended for eventual conversion into voiceband analog signals, the encoded analog content of the sub-rate channels within the 1.544 Mbps or ISDN PRA signal shall be limited as specified in Section 4.5.10..

4.5.8.2.6 Unequipped sub-rate channels. The permissible code words for unequipped μ -255 encoded sub-rate channels of terminal equipment connected to 1.544 Mbps digital services for ISDN PRA shall be limited to those corresponding to signals of either polarity, of magnitude equal to or less than X48, where code word, XN is derived by:

- $XN = (255 - N)$ base 2
- $XN = (127 - N)$ base 2

4.5.8.3 Limitations on TE Connecting to PSDS (Types I, II and III).

If PSDS (Types I, II and III) terminal equipment contains an analog to digital converter, or generates signals directly in digital form that are intended for eventual conversion into voiceband analog signals, the encoded analog content of the digital signal shall be limited as specified in Section 4.5.10.

4.5.8.3.1 Pulse repetition rate.

For PSDS (Type II) the pulse repetition rate shall be a maximum of (144,000 \pm 5) pulses per second; for PSDS (Type III) the pulse repetition rate shall be a maximum of (160,000 \pm 5) pulses per second.

4.5.8.3.2 Template for maximum output pulse.

When applied to a 135 Ω resistor, the instantaneous amplitude of the largest isolated output pulse obtainable from the approved terminal equipment shall fall within the template of section 4.5.8.3.2 (a) for PSDS Type II or 4.5.8.3.2 (b) for PSDS Type III. The limiting pulse template shall be defined by passing an ideal 50% duty cycle rectangular pulse within the amplitude/pulse rate characteristics of (a) or (b) through a 1-pole low-pass filter with a -3 dB frequency of 260 kHz.

Pulse Characteristics Template	4.5.8.3.2 (a) PSDS Type II	4.5.8.3.2 (b) PSDS Type III
Pulse Height	2.6 V \pm 5%	2.4 V \pm 5%
Pulse Width	(3472.2 \pm 150) ns	(3125 \pm 100) ns
Max Rise or Fall Time - (From 10% to 90% points)	100 ns	(1.2 \pm 0.2) μ s

4.5.8.4 Limitations on terminal equipment connected to ISDN BRA.

If approved terminal equipment connecting to an ISDN BRA interface contains an analog-to-digital converter, or generates signals directly in digital form that are intended for eventual conversion into voiceband analog signals, the encoded analog content of the bearer channels within the ISDN BRA signal shall be limited as specified in Section 4.5.10.

4.5.9 Signal Power Limitations for ADSL Terminal Equipment

ADSL modems shall operate within the aggregate signal power limitations of 4.5.9.1, the power spectral density limitations of 4.5.9.2 and the longitudinal output voltage limitations of 4.5.9.3.

4.5.9.1 Aggregate signal power

ADSL modems shall operate with an aggregate signal power of less than +13.0 dBm into 100 Ω over the frequency range of 25.875 to 138 kHz.

4.5.9.2 Power spectral density

ADSL modem's power spectral density (PSD) shall not exceed the PSD Mask as defined by the table below:

Frequency Band (kHz)	Equation for the PSD Mask (dBm/Hz)
$0.200 < f < 4$	-97.5
$4 < f < 25.875$	$-92.5 + 21.5 \times \log_2(f/4)$
$25.875 < f < 138$	-34.5
$138 < f < 307$	$-34.5 - 48 \times \log_2(f/138)$
$307 < f < 1221$	-90
$1221 < f < 1630$	-90 peak, with max power in the [f,f+1 MHz] window of $(-90 - 48 \times \log_2(f/1221) + 60)$ dBm
$1630 < f < 30000$	-90 peak, with max power in the [f,f+1 MHz] window of -50 dBm

NOTES:

- 1.) All PSD measurements are in 100 Ω .
- 2.) The breakpoint frequencies and PSD values are exact; the indicated slopes are approximate.
- 3.) Above 25.875 kHz, the peak PSD shall be measured with a minimum resolution bandwidth of 10 kHz.
- 4.) The power in a 1 MHz sliding window is averaged over a 1 MHz bandwidth, starting at the measurement frequency.

4.5.9.3 Longitudinal output voltage

ADSL modems shall meet the voiceband longitudinal voltage limitations of 4.5.4.1 as well as the limitations of 4.5.5.2.1 for a center frequency of 8 kHz, which covers the frequency span from 4 to 12 kHz. In addition, using the illustrative longitudinal output voltage measurement circuit in Figure 4.5, ADSL modems shall limit longitudinal output voltage to the values shown in the table below:

Frequency Band (kHz)	Maximum Longitudinal Output Voltage (rms) in all 4 kHz bands averaged over a minimum period of 1 second
$10 < f < 211$	-50 dBV (or -51.3 dBV using a 3 kHz bandwidth)
$211 < f < 844$	-80 dBV (or -81.3 dBV using a 3 kHz bandwidth)

NOTES:

- 1.) The first frequency band is the operating band as defined by the frequency points at which the PSD is approximately 30 dB down from the peak mask value. Alternatively, the measured 30 dB points may be used to define the operating band's lower and upper frequency points.
- 2.) The upper frequency point is four times the upper, operating band frequency.
- 3.) The alternative requirements of -51.3 dBV and -81.3 dBV include a -1.3 dB correction factor associated with using a 3 kHz bandwidth rather than the ideal 4 kHz bandwidth.

4.5.10. Encoded Analog Content Limits.

If approved terminal equipment contains an analog-to-digital converter or generates a data bit stream that is intended for eventual conversion into voiceband analog signals in the PSTN, the encoded analog content of the digital signal shall be limited as specified in this clause.

The maximum equivalent power of encoded analog content derived by a zero level decoder test configuration shall not exceed the following limits when averaged over any 3-second time interval:

- -12 dBm for all signals other than live voice, V.90 or V.92 modems, or network control signals.
- -6 dBm for V.90 or V.92 modems.
- -3 dBm for network control signals.

The zero level decoder test configuration is intended to simplify measurement of the maximum encoded analog signal. The use of a zero level encoder for test purposes shall not be interpreted as permission to exceed the encoded analog content limits given above when analog or digital loss is inserted in the PSTN connection by wireline carriers.

4.6 TRANSVERSE BALANCE LIMITATIONS

4.6.1 Technical description and application

The Transverse Balance_{m-l} coefficient is expressed as:

$$\text{Balance}_{m-l} = 20 \log_{10} [e_M / e_L]$$

- 4.6.1.1 Where e_L is the longitudinal voltage produced across a longitudinal termination Z_1 and e_M is the metallic voltage across the tip-ring or tip-1 and ring-1 interface of the input port when a voltage (at any frequency between f_1 and f_2 , see Table 4.11) is applied at all values of dc loop current that the port under test is capable of drawing when attached to the appropriate loop from a balanced source with a metallic impedance Z_0 (see Table 4.11) The source voltage shall be set such that $e_M = E$ (Volts) (see Table 4.11 when a termination of Z_0 is substituted for the terminal equipment.)
- 4.6.1.2 The minimum transverse balance coefficient specified in this section (as appropriate) shall be equaled or exceeded for all 2-wire network ports, OPS line ports and the transmit pair (tip and ring) and receive pair (tip-1 and ring-1) of all 4-wire network ports simulator circuits at all values of dc loop current that the port under test is capable of drawing when attached to the appropriate loop (See Figure 1.4). An illustrative test circuit that satisfies the above conditions is shown in Figure 4.7 for analog and Figure 4.8 for digital and sub-rate; other means may be used to determine the transverse balance coefficient specified herein, provided that adequate documentation of the appropriateness, precision, and accuracy of the alternative means is provided.
- 4.6.1.3 The minimum transverse balance requirements specified below shall be equaled or exceeded under all reasonable conditions of the application of earth ground to the equipment or protective circuitry under test.

Table 4.11 Transverse Balance Test Criteria

	Analog voiceband	Sub-rate digital	1.544 Mbps digital
Longitudinal Termination - Z_l	500 Ω	See Table 4.11	90 Ω
Metallic Source Impedance - Z_0	600 Ω	135 Ω	100 Ω
Lower Frequency - f_1	200 Hz	200 Hz	12 kHz
Upper Frequency - f_2	4 kHz	(see note)	1.544 MHz
Metallic voltage for Test - E	0.775 V	0.367 V	0.316 V

NOTE: The upper frequency shall equal the digital line rate for the sub-rate service under test (See Table 4.12.)

4.6.2 Analog voiceband equipment

All approved analog voiceband equipment shall be tested in the off-hook state. The minimum transverse balance requirement in the off-hook state shall be 40 dB, throughout the range of frequencies specified in Table 4.11. For some categories of equipment, transverse balance requirements also apply to the on-hook state. When both off-hook and on-hook requirements apply, they shall be:

State	Frequency (f)	Balance
Off-hook	200 Hz \leq f \leq 4000 Hz	40 dB
On-hook	200 Hz \leq f \leq 1000 Hz	60 dB
On-hook	1000 Hz \leq f \leq 4000 Hz	40 dB

4.6.2.1 For analog one-port 2-wire terminal equipment with loop-start, ringdown, or inband signaling or for voiceband metallic channel applications, both off-hook and on-hook requirements shall apply.

4.6.2.2 For analog one port equipment with ground-start and reverse-battery signaling only off-hook requirements shall apply.

4.6.2.3 For analog approved protective circuitry for 2-wire applications with loop-start, ringdown, or inband signaling; or for voiceband metallic channel applications, both off-hook and on-hook requirements shall apply. Criteria shall be met with either terminal of the interface to other equipment connected to earth ground. The interface to other equipment shall be terminated in an impedance that will be

reflected to the telephone connection as $600\ \Omega$ in the off-hook state of the approved protective circuit, and the interface shall not be terminated in the on-hook state. The arrangement of Figure 4.12 shall be used.

- 4.6.2.4 For analog approved protective circuitry with ground-start and reverse-battery signaling only off-hook requirements shall apply. Criteria shall be met with either terminal of the interface to other equipment connected to earth ground. The interface to other equipment shall be terminated in an impedance that will be reflected to the telephone connection as $600\ \Omega$ in the off-hook state of the approved protective circuit. The arrangement of Figure 4.12 shall be used.
- 4.6.2.5 For analog multi-port equipment with loop-start signaling both off-hook and on-hook requirements shall apply. Criteria shall be satisfied for all ports when all the ports not under test are terminated in their appropriate networks, as will be identified below, and when interface connections other than the ports are terminated in circuits appropriate to that interface. The minimum transverse balance coefficients shall also be satisfied for all values of dc loop current that the approved equipment is capable of drawing through each of its ports when these ports are attached to the loop simulator circuit specified in this standard. The termination for all ports other than the particular one whose transverse balance coefficient is being measured shall have a metallic impedance of $600\ \Omega$ and a longitudinal impedance of $500\ \Omega$. Figure 4.9 shows this termination.
- 4.6.2.6 For analog multi-port equipment with ground-start and reverse-battery signaling, only off-hook requirements shall apply. Criteria shall be satisfied for all ports when all ports not under test are terminated in their appropriate networks as will be identified below, and when interface connections other than the ports are terminated in circuits appropriate to that interface. The minimum transverse balance coefficients shall be satisfied for all values of dc loop current that the approved equipment is capable of drawing through each of its ports when these ports are attached to the loop simulator circuit specified in this standard. The terminations for all ports other than the particular one whose transverse balance coefficient is being measured shall have a metallic impedance of $600\ \Omega$ and a longitudinal impedance of $500\ \Omega$. Figure 4.9 shows this termination.
- 4.6.2.7 For analog approved terminal equipment and protective circuitry for 4-wire network ports, both the off-hook and on-hook requirements shall apply. The pairs not under test shall be terminated in a metallic impedance of $600\ \Omega$. Other conditions are as follows:
 - 4.6.2.7.1 For analog approved protective circuitry with loop-start, ground-start, reverse battery, ringdown, or inband signaling; or for voiceband metallic channel applications. Criteria shall be met with either terminal of the interface to other equipment connected to earth ground. The interface to other equipment shall be terminated in an impedance that will result in $600\ \Omega$ at each of the transmit and receive pairs of the 4-wire telephone connection in the off-hook state of the approved protective circuit, and the interface shall not be terminated in the on-hook state. The arrangement of Figure 4.10 shall be used.

- 4.6.2.7.2 For analog multipoint equipment with loop start, ground start, and reverse battery, ringdown, or inband signaling; or for voiceband metallic channel applications. Criteria shall be satisfied for all network ports when all the ports not under test are terminated as defined below, and when interface connections other than the network ports are terminated in circuits appropriate to the interface. The criteria shall also be satisfied for all values of dc loop current that the approved equipment is capable of drawing through each port when the port is connected to the appropriate 4-wire loop simulator circuit. The terminations for both pairs of all network ports not under test shall have a metallic impedance of 600 Ω and a longitudinal impedance of 500 Ω . Figure 4.9 shows this termination.
- 4.6.2.8 For analog PBX equipment (or similar systems) with class B or class C off-premises interfaces, only off-hook requirements shall apply. Criteria shall be satisfied for all off-premises station interface ports when these ports are terminated in their appropriate networks for their off-hook state, and when all other interface connections are terminated in circuits appropriate to that interface. The minimum transverse balance coefficients shall also be satisfied for all values of dc loop current that the approved PBX is capable of providing through off-premises station ports when these ports are attached to the off-premises line simulator circuit specified in this standard.
- 4.6.2.9 For Type Z equipment with loop-start signaling, both off-hook and on-hook requirements shall apply. Equipment that has on-hook impedance characteristics that do not conform to the requirements of section 4.7 (e.g. Type Z), shall comply with minimum transverse balance requirements of 40 dB in the voiceband. See section 4.7.7 for conditions upon approval of "Type Z" equipment.
- 4.6.3 Digital equipment
The minimum transverse balance requirements for approved terminal equipment connected to digital terminal equipment shall be equaled or exceeded for the range of frequencies applicable for the equipment under test and under all reasonable conditions of the application of earth ground to the equipment. All such terminal equipment shall have a transverse balance in the acceptable region of either Figure 4.11(a), or Figure 4.11(b), as appropriate, for the range of frequencies shown in Table 4.12, for the specified digital terminal equipment in question. The metallic impedance used for the transverse balance measurements for all sub-rate, PSDS and BRA services shall be 135 Ω and for 1.544 Mbps (including ISDN PRA) shall be 100 Ω . The longitudinal termination for 1.544 Mbps (including ISDN PRA), ISDN BRA, PSDS terminal equipment and sub-rate services shall be as defined in Table 4.12.
- 4.6.4 ADSL equipment
In addition to meeting the transverse balance limitations for analog voiceband equipment in Section 4.6.2, ADSL terminal equipment's transverse balance shall equal or exceed the values in Figure 4.11(a) over the entire range of frequencies between 13.6 kHz to 1625 kHz (see Table 4.12). Alternatively, a narrower frequency range may be used that is defined by the points at which the measured power spectral density is 20 dB down from the maximum level associated with both the maximum rate upstream and downstream signals. The metallic impedance used for

` TIA-968-A

the transverse balance measurements for ADSL shall be 100 Ω . The longitudinal termination shall be 90 Ω , see Table 4.12.

**Table 4.12 Frequency Ranges Of Transverse Balance Requirements
for equipment connecting to digital services**

Digital Interface	Frequency range (kHz)	Longitudinal Termination (R_L) (Ω)	Metallic Termination (R_M) (Ω)
2.4	0.2 to 2.4	500	135
2.4 + SC	0.2 to 3.2	500	135
4.8	0.2 to 4.8	500	135
4.8 + SC	0.2 to 6.4	500	135
9.6	0.2 to 9.6	500	135
9.6 + SC (note)	0.2 to 12.8	500/90	135
19.2 (see note)	0.2 to 19.2	500/90	135
19.2 + SC (see note)	0.2 to 25.6	500/90	135
38.4 (see note)	0.2 to 38.4	500/90	135
38.4 + SC (see note)	0.2 to 51.2	500/90	135
56 (see note)	0.2 to 56	500/90	135
56 + SC (see note)	0.2 to 72	500/90	135
64 (see note)	0.2 to 72	500/90	135
BRA	0.2 to 192	500/90	135
DS1 (1544 kHz)	12 to 1544	90	100
ADSL	13.6 to 1625	90	100

NOTE: For 0.2 to 12 kHz the longitudinal termination (R_L) shall be 500 Ω and above 12 kHz the longitudinal termination (R_L) shall be 90 Ω .

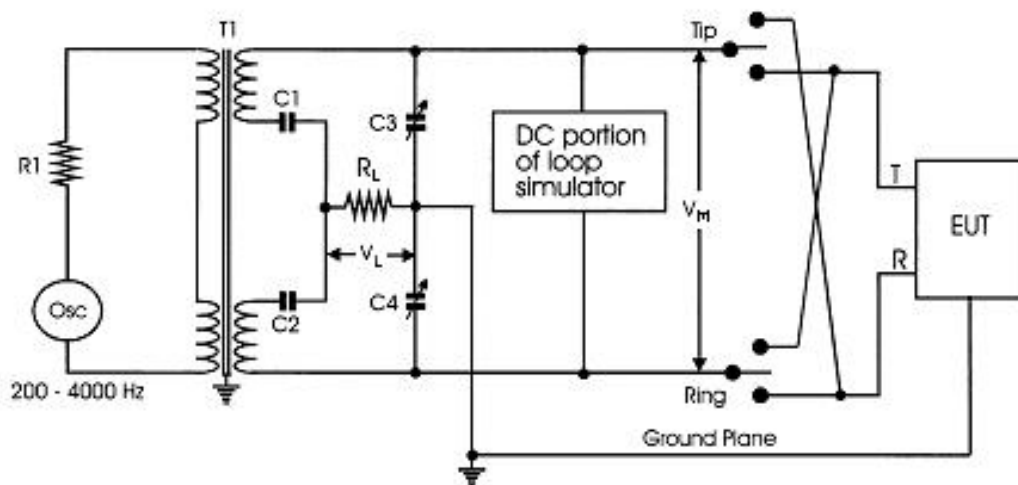

T ₁	600 Ω: 600 Ω split audio transformer
C ₁ , C ₂	8 μF, 400 V dc, matched to within 0.1%
C ₃ , C ₄	100 to 500 pF adjustable trimmer capacitors
Osc	Audio oscillator with source resistance R ₁ less than or equal to 600 Ω
R ₁	Selected such that Z _{OSC} + R ₁ = 600 Ω
R _L	500 Ω

NOTES:

1. V_M shall not be measured at the same time as V_L.
2. The test circuit shall be balanced to 20 dB greater than the equipment standard for all frequencies specified (using trimmer capacitors C₃ and C₄), with a 600 Ω resistor substituted for the equipment under test.
3. Exposed conductive surfaces on the exterior of the equipment under test shall be connected to the ground plane for this test.
4. When the Terminal Equipment makes provision for an external connection to ground, the Terminal Equipment shall be connected to ground. When the Terminal Equipment makes no provision for an external ground, the Terminal Equipment shall be placed on a ground plane that is connected to ground and has overall dimensions at least 50% greater than the corresponding dimensions of the Terminal Equipment. The Terminal Equipment shall be centrally located on the ground plane without any additional connection to ground.

Figure 4.7 Illustrative Test Circuit for Transverse Balance (Analog)

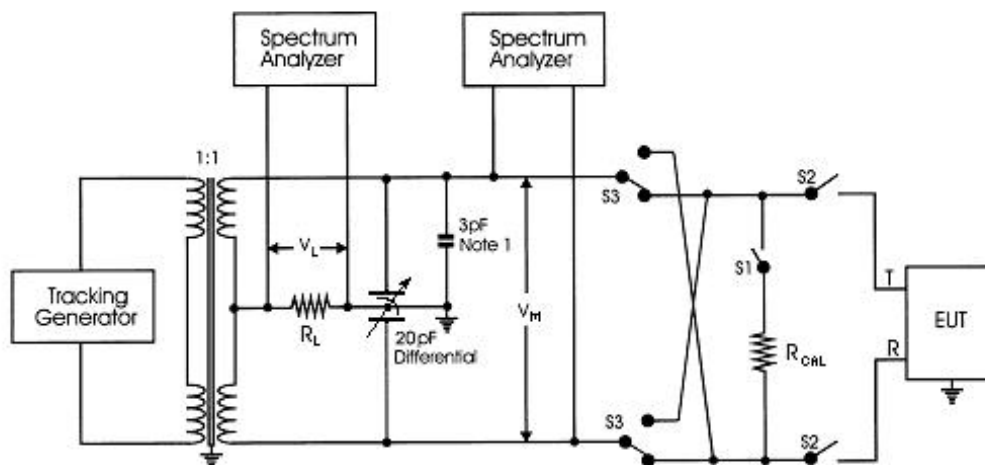

T1	100/135 Ω :100/135 Ω wide-band transformer (100 Ω for 1.544 Mbps devices and 135 Ω for sub-rate devices.)
20 pF Differential	Optimally a dual-stator air-variable RF capacitor that maintains a constant capacitance between stators while providing a variable capacitance from either stator to ground.
3 pF	Composition RF capacitor
R _{CAL}	100/135 Ω (See Note 2)
R _L	90/500 Ω : A non-inductive precision resistor (chosen according to Table 4.12).

NOTES:

1. The 3 pF capacitor may be placed on either line of the test set, as required, to obtain proper balancing of the bridge.
2. Use an R_{CAL} value of 100 Ω for 1.544 Mbps devices and 135 Ω for sub-rate devices.
3. The effective output impedance of the tracking generator shall match the appropriate test impedance. See Note 2. The spectrum analyzer's input shall be differentially balanced to measure V_M.
4. The impedance of the Tracking Generator shall be chosen to match the Metallic Termination (R_M) according to Table 4.12.
5. The transformer should be a wide band transformer with a 1:1 impedance ratio.

Figure 4.8 Illustrative Test Circuit for Transverse Balance (Digital)

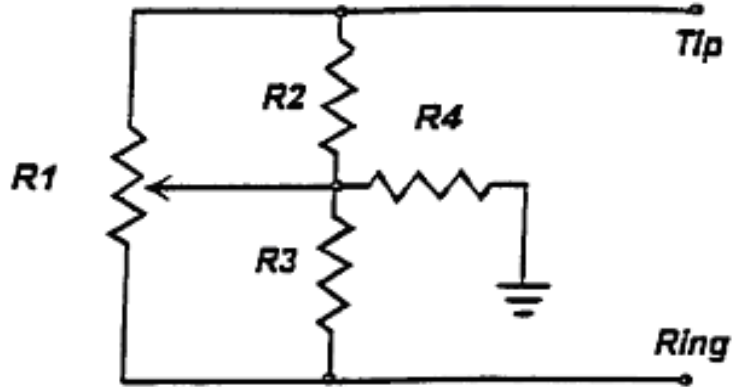

NOTES:

	R_1	$R_2 = R_3$	R_4
for analog voiceband	300 k Ω ,	300 Ω	350 Ω
for sub-rate digital	100 k Ω ,	67.5 Ω	56.3 Ω
for 1.544 Mbps	100 k Ω ,	50 Ω	65 Ω

R_1 is used to adjust termination balance. Balance of this termination shall be adjusted to: at least 60 dB between 200 and 1000 Hz; at least 40 dB between 1000 and 4000 Hz; and at least 35 dB at 1.544 MHz.

Figure 4.9 Off-Hook termination of Multiport Equipment for Ports Not under Test

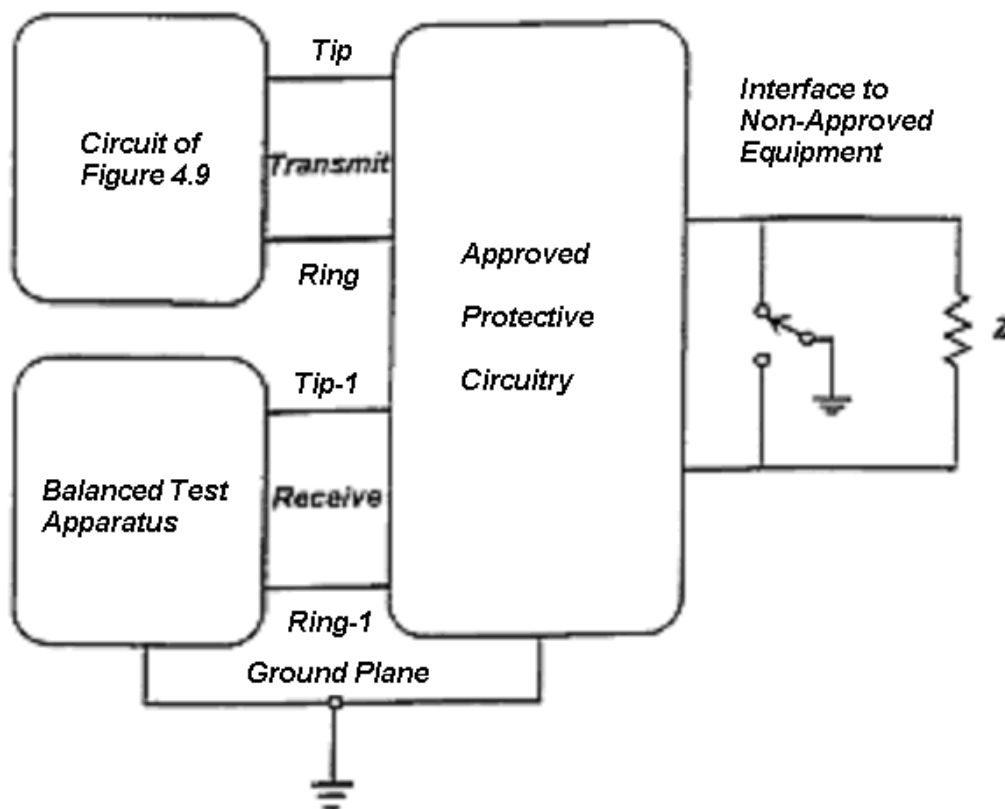
**NOTES:**

1. Z shall be selected so that the reflected impedance at tip-1 and ring-1 is 600 Ω , 135 Ω , or 100 Ω depending on service type of EUT.
2. Configuration shown is for measurement-of receive pair.

Figure 4.10 Required Termination for Connections to Non-Approved Equipment

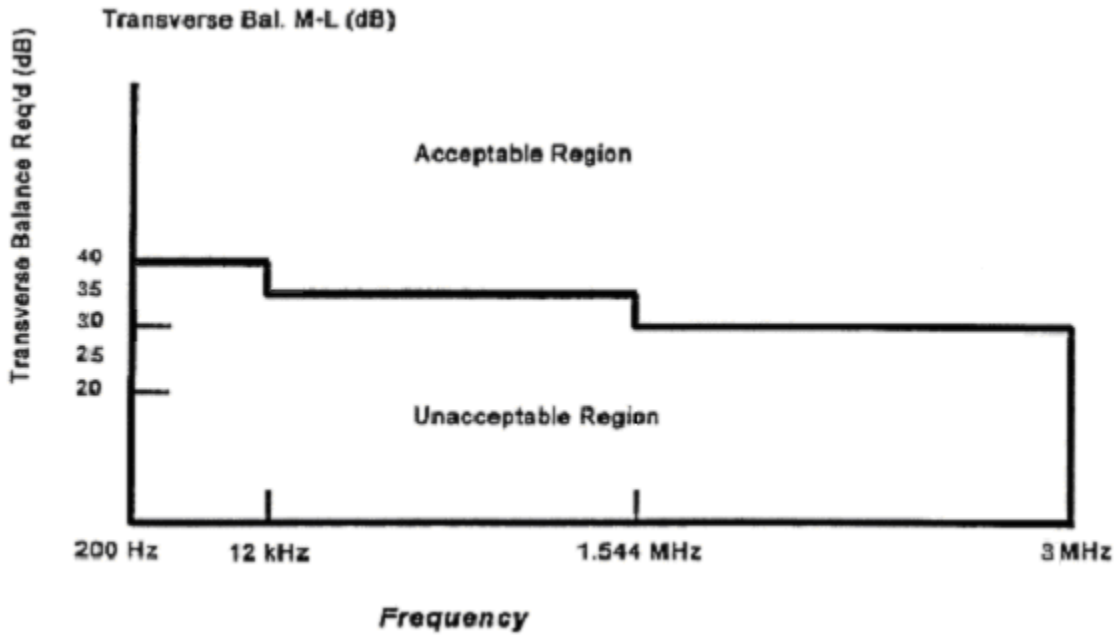

Figure 4.11(a) Transverse Balance Requirements for ISDN BRA, 1.544 Mbps (including ISDN PRA) and ADSL

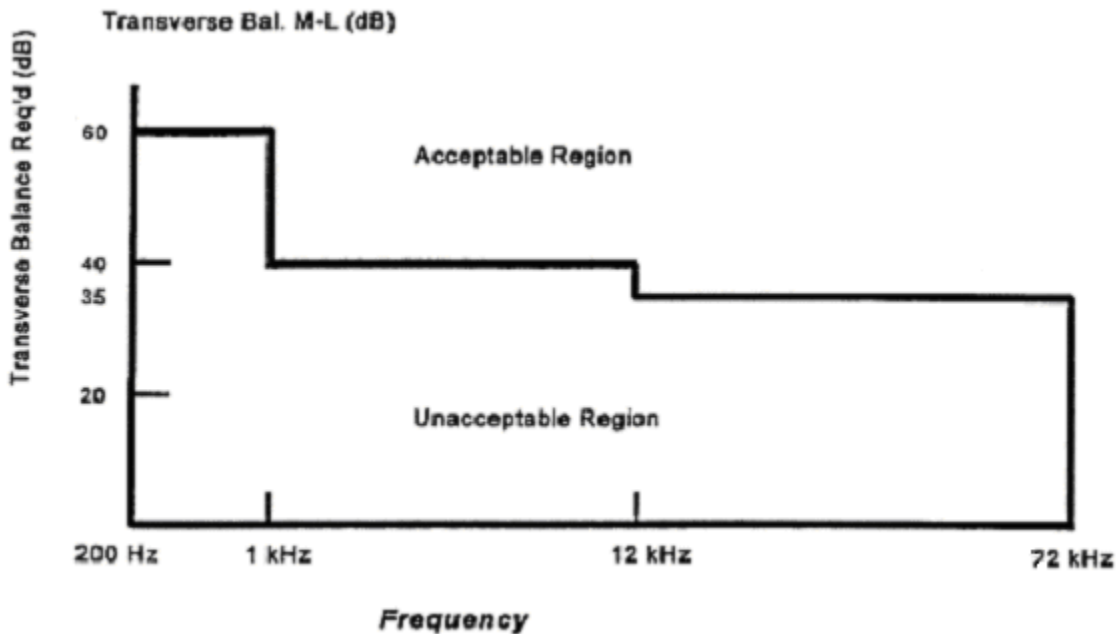
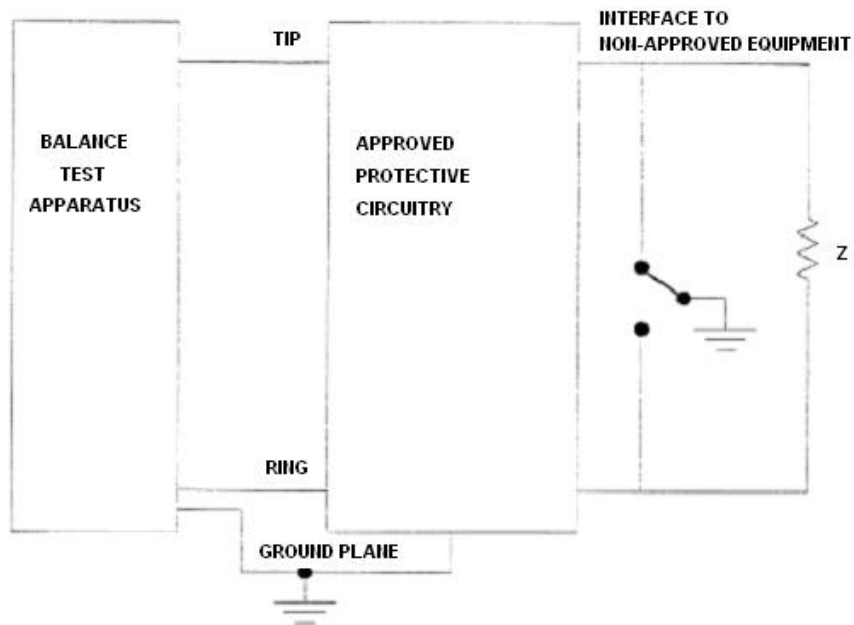

Figure 4.11(b) Transverse Balance Requirements for PSDS and Sub-Rate Services



NOTE: Z shall be selected so that the reflected impedance at tip and ring is $600\ \Omega$, $135\ \Omega$, or $100\ \Omega$ depending on the service type of EUT

Figure 4.12 Required termination for connections to non-approved equipment

4.7 ON-HOOK IMPEDANCE LIMITATIONS

4.7.1 General: Requirements in this section shall apply to the tip and ring conductors of 2-wire interfaces. These requirements also shall apply to 4-wire loop-start or ground-start interfaces, in the following configuration:

4.7.1.1 The tip and ring conductors shall be connected together and treated as one of the conductors of a tip and ring pair.

4.7.1.2 The tip-1 and ring-1 conductors shall be connected together and treated as the other conductor of a tip and ring pair.

NOTE: Throughout this section, references will be made to simulated ringing. Ringing voltages which shall be used and impedance limitations associated with simulated ringing are shown in Table 4.13.

Table 4.13 Simulated Ringing Voltages and Impedance Limitations

Ringling type	Range of compatible ringling frequencies (Hz)	Simulated ringling voltage superimposed on 56.5 V dc	Impedance limitation (Ω)
A	20 \pm 3	40 to 130 V rms	1400
	30 \pm 3	40 to 130 V rms	1000
B	15.3 to 34	40 to 130 V rms	1600
	>34 to 49	62 to 130 V rms	1600
	>49 to 68	62 to 150 V rms	1600

- 4.7.2 Limitations on individual equipment intended for operation on loop-start telephone facilities Approved terminal equipment and approved protective circuitry shall conform to the following limitations.
- 4.7.2.1 On-hook resistance, metallic and longitudinal (up to 100 V dc). The on-hook dc resistance between the tip and ring conductors of a loop start interface, and between each of the tip and ring conductors and earth ground, shall be greater than 5 M Ω for all dc voltages up to and including 100 V.
- 4.7.2.2 On-hook resistance, metallic and longitudinal (100 V to 200 V dc). The on-hook dc resistance between tip and ring conductors of a loop start interface, and between each of the tip and ring conductors and earth ground shall be greater than 30 k Ω for all dc voltages between 100 and 200 V.
- 4.7.2.3 DC current during ringing. During the application of simulated ringing, as listed in Table 4.13, to a loop start interface, the total dc current shall not exceed 3.0 mA. The equipment shall comply for each ringing type that is listed as part of the ringer equivalence.
- 4.7.2.4 Ringing frequency impedance (metallic). During the application of simulated ringing, as listed in Table 4.13 to a loop start interface, the impedance between the tip and ring conductors (defined as the quotient of applied ac voltage divided by resulting true rms current) shall be greater than or equal to the value specified in Table 4.13. The equipment shall comply for each ringing type that is listed as part of the ringer equivalence.
- 4.7.2.5 Ringing Frequency Impedance (longitudinal). During the application of simulated ringing, as listed in Table 4.13, to a loop start interface, the impedance between each of the tip and ring conductors and ground shall be greater than 100 k Ω . The equipment shall comply with each ringing type listed in the ringer equivalence.

4.7.3 Limitations on individual equipment intended for operation on ground start telephone facilities

Approved terminal equipment and approved protective circuitry shall conform to the following limitations:

4.7.3.1 DC current during ringing

During the application of simulated ringing, as listed in Table 4.13, to a ground start interface, the total dc current flowing between tip and ring conductors shall not exceed 3.0 mA. The equipment shall comply for each ringing type listed as part of the ringer equivalence.

4.7.3.2 Ringing frequency impedance (metallic)

During the application of simulated ringing, as listed in Table 4.13, to a ground start interface, the total impedance of the parallel combination of the ac impedance across tip and ring conductors and the ac impedance from the ring conductor to ground (with ground on the tip conductor) shall be greater than the value specified in Table 4.13. The equipment shall comply for each ringing type listed as part of the ringer equivalence.

4.7.4 Ringer Equivalence Definition

The ringer equivalence number shall be the value determined in section 4.7.4.1 or 4.7.4.2, as appropriate, followed by the ringer type letter indicator representing the frequency range for which the number is valid. If Ringer Equivalence is to be stated for more than one Ringing Type, testing shall be performed at each frequency range to which Ringer Equivalence is to be determined in accordance with the above, and the largest resulting Ringer Equivalence Number so determined shall be associated with each Ringing Type letter designation for which it is valid.

4.7.4.1 For individual equipment intended for operation on loop-start telephone facilities, the ringer equivalence shall be five times the impedance limitation listed in Table 4.13, divided by the minimum measured ac impedance, as defined in section 4.7.2.1.3, during the application of simulated ringing as listed in Table 4.13.

4.7.4.2 For individual equipment intended for operation on ground-start telephone facilities, the ringer equivalence shall be five times the impedance limitation listed in Table 4.13, divided by the minimum measured ac impedance, defined in section 4.7.3.2, during the application of simulated ringing as listed in Table 4.13.

4.7.5 Maximum ringer equivalence

All approved terminal equipment and approved protective circuitry that can affect the ringing frequency impedance shall be assigned a Ringer Equivalence. The sum of all such Ringer Equivalences on a given telephone line or loop shall not exceed 5. In some cases, a system that has a total Ringer Equivalence of 5 or more may not be usable on a given telephone line or loop.

4.7.6 OPS interfaces for PBX with DID (ring trip requirement)

PBX ringing supplies whose output appears on the off-premises interface leads

shall not trip when connected to the following tip-to-ring impedance that terminates the off-premises station loop: A terminating impedance composed of the parallel combination of a 15 k Ω resistor and an RC series circuit (resistor and capacitor) whose ac impedance is as specified in Table 4.14.

Table 4.14

Ringing freq (Hz)	AC impedance (Ω)	
	Class B or C	Class A
20 \pm 3	7000/N	1400
30 \pm 3	5000/N	1000

N = Number of ringer equivalences, as specified by the manufacturer, which can be connected to the off-premises station loop.

4.7.7 Type Z Ringers

Equipment that has on-hook impedance characteristics that do not conform to the requirements of this section may be conditionally approved, notwithstanding the requirements of this section and provided that it is labeled with a Ringing Type designation "Z". It should be noted that approval of equipment bearing the designation "Z" does not necessarily confer any right of connection to the telephone network under these criteria. Any equipment approved with the type Z designation may only be used with the consent of the local telephone company, provided that the local telephone company does not discriminate in its treatment of equipment bearing the type Z designation.

4.7.8 Transitioning to the Off-Hook State

Except as provided in 4.7.8.1 and 4.7.8.2 below, approved terminal equipment and approved protective circuitry shall not by design leave the on-hook state by operations performed on tip and ring leads for any other purpose than to request service or answer an incoming call. Make-busy indications shall be transmitted by the use of make-busy leads only as defined in section 1.3.26.

4.7.8.1 Manual programming of memory dialing numbers

Terminal equipment the user places in the off-hook state for the purpose of manually placing telephone numbers in internal memory for subsequent automatic or repertory dialing shall be acceptable for connection to the telephone network provided it meets all other applicable requirements.

4.7.8.2 Automatic stutter dial tone detection

Terminal equipment that automatically goes off-hook for the purpose of checking for stutter dial tone shall be acceptable for connection to the telephone network provided it meets all other applicable requirements and all of the following specifications and conditions:

- a) the device performs no periodic testing for stutter dial tone;
- b) the device makes an off-hook stutter dial tone check no more than once after a subscriber completes a call, and completes the check no earlier than 4 seconds after the subscriber hangs-up;
- c) the device makes an off-hook stutter dial tone check after an unanswered call no more than once;
- d) the device performs no off-hook stutter dial tone check after an unanswered incoming call if the visual message indicator is already lit;
- e) the device takes the line off-hook for no more than 2.1 seconds per stutter dial tone check. Since the equipment cannot begin checking for stutter dial tone until dial tone is present, this 2.1 second interval begins when dial tone is applied to the line. If dial tone is not applied within 3 seconds, the equipment should abandon the stutter dial tone check;
- f) the device synchronizes off-hook checks when multiple stutter dial tone detection and visual signaling devices are attached to the same line so that only one check is made per calling event for a single line; and,
- g) the device does not block dial tone to a subscriber attempting to initiate a call as an off-hook stutter dial tone detection check is occurring.

4.8 BILLING PROTECTION

- 4.8.1 Call duration requirements on data equipment connected to the public switched network, or to tie trunks, or to private lines that access the public switched network.

Approved data terminal equipment and approved protective circuitry shall comply with the following requirements when answering an incoming call, except in off-hook states in which the signals are transmitted and/or received by electro-acoustic transducers only.

The preceding paragraph shall be applicable to approved terminal equipment and approved protective circuitry employed with digital services where such digital services are interconnected with the analog telephone network.

- 4.8.1.1 Approved protective circuitry. Approved protective circuitry connected to associated data equipment shall assure that the following signal power limitations are met for at least the first 2 seconds after the off-hook condition is presented to the telephone network in response to an incoming call:

- 4.8.1.1.1 The total power of signals that appear at the protective circuitry/telephone network interface for delivery to the telephone network, when measured with the appropriate loop simulator circuit or a 600 ohm termination shall be limited to -55 dBm within the voiceband ; and

- 4.8.1.1.2 Signals that appear at the protective circuitry-associated data equipment interface for delivery to associated data equipment shall be limited as follows: for any received signal power (appearing at the protective circuitry-telephone network interface) up to 0 dBm (within the voiceband), the power of signals delivered to associated data equipment shall be no greater than the signal power that would be delivered as a result of received signal power of -55 dBm.

- 4.8.1.2 Approved terminal equipment.

Approved terminal equipment for data applications shall assure that, when an incoming telephone call is answered, the answering terminal equipment prevents both transmission and reception of data for at least the first two seconds after the answering terminal equipment transfers to the off-hook condition. For the purpose of this requirement, a fixed sequence of signals that is transmitted (and originated within) and/or received by the approved terminal equipment each time it answers an incoming call shall not be considered data, provided that such signals are for one or more of the following purposes:

- a) Disabling echo control devices,
- b) Adjusting automatic equalizers and gain controls,
- c) Establishing synchronization, or
- d) Signaling the presence and if required, the mode of operation, of the data terminal at the remote end of a connection.

- 4.8.2 Voice and data equipment on-hook signal requirements for equipment connected to

the public switched network, or to tie trunks, or to private lines that access the public switched network.

Approved protective circuitry and approved terminal equipment shall comply with the following:

- 4.8.2.1 The total power delivered into a 2-wire loop simulator circuit or into the transmit and receive pairs of a 4-wire loop simulator or into a $600\ \Omega$ termination (where appropriate) in the on-hook state, by loop-start or ground-start equipment, shall not exceed $-55\ \text{dBm}$ within the voiceband. Approved protective circuitry shall also assure that for any input level up to $10\ \text{dB}$ above the overload point, the power to a 2-wire loop simulator circuit or the transmit and receive pairs of a 4-wire loop simulator circuit or into a $600\ \Omega$ termination (where appropriate) does not exceed the above limits.
- 4.8.2.2 The total power delivered into a 2-wire loop simulator circuit or into the transmit and receive pairs of a 4-wire loop simulator circuit, in the on-hook state, by reverse battery equipment shall not exceed $-55\ \text{dBm}$ within the voiceband, unless the equipment is arranged to inhibit in-coming signals.
- 4.8.3 Voice and data equipment loop current requirements for equipment connected to the public switched network
The loop current through approved terminal equipment or approved protective circuitry, when connected to a 2-wire or 4-wire loop simulator circuit with the $600\ \Omega$ resistor and $500\ \mu\text{F}$ capacitor of the 2-wire loop simulator circuit or both pairs of the 4-wire loop simulator circuit disconnected shall, for at least 5 seconds after the equipment goes to the off-hook state that would occur when answering an incoming call:

- 4.8.3.1 Be at least as great as the current obtained in the same loop simulator circuit with minimum battery voltage and a maximum loop resistance when a 200 Ω resistance is connected across the tip and ring of the 2-wire loop simulator circuit or connected across the tip/ring and tip-1/ring-1 conductors (tip and ring connected together and tip-1 and ring-1 connected together) of the 4-wire loop simulator circuit in place of the approved terminal equipment or approved protective circuitry; or
- 4.8.3.2 Not decrease by more than 25% from its maximum value attained during this 5-second interval; unless the equipment is returned to the on-hook state during the above 5-second interval.
- 4.8.3.3 The requirements of 4.8.3.1 and 4.8.3.2 shall also apply in the hold state and any off-hook state.
- 4.8.4 Signaling interference requirements
- 4.8.4.1 The signal power delivered to the network interface by the approved terminal equipment and from signal sources internal to approved protective circuitry in the 2450 Hz to 2750 Hz band shall be less than or equal to the power present simultaneously in the 800 Hz to 2450 Hz band for the first 2 seconds after going to the off-hook state.
- 4.8.4.2 Approved terminal equipment for connection to sub-rate or 1.544 Mbps digital services shall not deliver digital signals to the telephone network with encoded analog content energy in the 2450 to 2750 Hz band unless at least an equal amount of encoded analog energy is present in the 800 to 2450 Hz band for the first two seconds after going to the off-hook state.
- 4.8.5 On-hook requirements for approved subrate and 1.544Mbps digital terminal equipment. Approved terminal equipment and approved protective circuitry shall comply with the following:
- 4.8.5.1 The total power delivered to the telephone network in the on-hook state as derived by a zero level decoder shall not exceed -55 dBm equivalent power for digital signals within the voiceband.
- 4.8.5.2 Approved protective circuitry shall also assure that the power to a zero level decoder does not exceed the above limits for any input level up to 10 dB above the overload point.
- 4.8.5.3 Reverse battery interface. The total power derived within the voiceband by a zero level decoder, in the on-hook state, by reverse battery equipment, shall not exceed -55 dBm, unless the equipment is arranged to inhibit incoming signals.
- 4.8.6 Off-hook signal requirements for approved 1.544 Mbps terminal equipment
Off-hook signal requirements for approved terminal equipment connecting to 1.544 Mbps digital services. Upon entering the normal off-hook state, in response to alerting, for sub-rate channels, approved terminal equipment shall

continue to transmit the signaling bit sequence representing the off-hook state for 5 seconds, unless the equipment is returned to the on-hook state during the above 5-second interval.

4.8.7 Operating requirements for direct inward dialing.

4.8.7.1 For approved terminal equipment, the off-hook state shall be applied within 0.5 seconds of the time that:

4.8.7.1.1 The terminal equipment permits the acceptance of further digits that may be used to route the incoming call to another destination.

4.8.7.1.2 The terminal equipment transmits signals towards the calling party, except for the call progress tones, i.e., busy, reorder and audible ring, and the call is:

- a) Answered by the called, or another station;
- b) Answered by the attendant;
- c) Routed to a customer controlled or defined recorded announcement, except for “number invalid,” “not in service” or “not assigned;”
- d) Routed to a dial prompt; or
- e) Routed back to the public switched telephone network or other destination and the call is answered. If the status of the answered call cannot be reliably determined by the terminal equipment through means such as, detection of answer supervision or voice energy, removal of audible ring, etc., the off-hook state shall be applied after an interval of not more than 20 seconds from the time of such routing. The off-hook state shall be maintained for the duration of the call.

4.8.7.2 For approved protective circuitry:

4.8.7.2.1 Approved protective circuitry shall block transmission incoming from the network until an off-hook signal is received from the terminal equipment.

4.8.7.2.2 Approved protective circuitry shall provide an off-hook signal within 0.5s following the receipt of an off-hook signal from the terminal equipment and shall maintain this off-hook signal for the duration of the call.

5 COMPLAINTS PROCEDURES

The complaints procedures are provided in 47 CFR Part 68.

This page left intentionally blank.

6 CONNECTORS

Connection of terminal equipment to the telephone network shall be made through a connector conforming to this section or by direct attachment to wiring installed by the provider(s) of wire line telecommunications including, but not limited to, splicing, bridging, twisting, and soldering.

6.1 SPECIFICATIONS

6.1.1 General

The US customary units are shown in parentheses throughout this section. US customary units were the original dimensional units used in designing the plugs and jacks shown in the following pages. The dimensions shown without parenthesis are in SI (Systeme Internationale) units (i.e. the International System of measurement). The SI dimensional units are derived from the US customary units by multiplying inches by 25.4 to derive the exact conversion in millimeters with no rounding-off of the resulting decimal value. The number of decimal places to which the conversion is taken by adding a particular number of zeroes to the right end of the resulting SI value, where required, is governed by the concept that when the calculated SI dimensional unit is divided by 25.4, the resulting inches calculation will be exactly that shown in the parenthesis (the original design dimension). The conversion to SI force units, Newton (N), is rounded off to a number of decimal places that will result in the calculated SI force value being within less than 1% of the original US customary force unit value located adjacent in parenthesis (the original design value). The rationale for this is that this will bring the force conversions to within the degree of accuracy of the force-measuring device and avoid the carrying of an unrealistic number of decimal places which would otherwise result from an exact conversion. The plugs and jacks described in this section represent the standard connections to be used for connections to the telephone network. The plug and jack designs shown are representative of generic types, and should not be interpreted as the only designs that may be used. Design innovation and improvement is anticipated; but for interchangeability to be maintained, alternative designs (the "or equivalent" permitted in this standard) shall be compatible with the plugs and jacks shown. The interface dimensions between mating plugs and jacks shall be maintained. Hardware used to mount, protect, and enclose standard jacks is not described. The only requirement on connecting blocks, housings, dust covers, outdoor boxes, and the like that contain standard network jacks is that they shall accept standard plugs with cordage. For special purpose applications, plugs may be made longer than shown or adapted for direct use on equipment or apparatus without cordage. The sliding modular plug used on the back of many modular wall telephone sets is an example of such a special purpose application. It is the responsibility of the designers and manufacturers of communication equipment who use such plugs to assure that they are compatible with the hardware used to mount standard jacks with which they plan to interface. For the purposes of this section, hard gold and contact performance equivalent to gold shall be determined in accordance with the standards detailed in TIA TSB 31-B.

6.1.1.1 Miniature 6-position plug

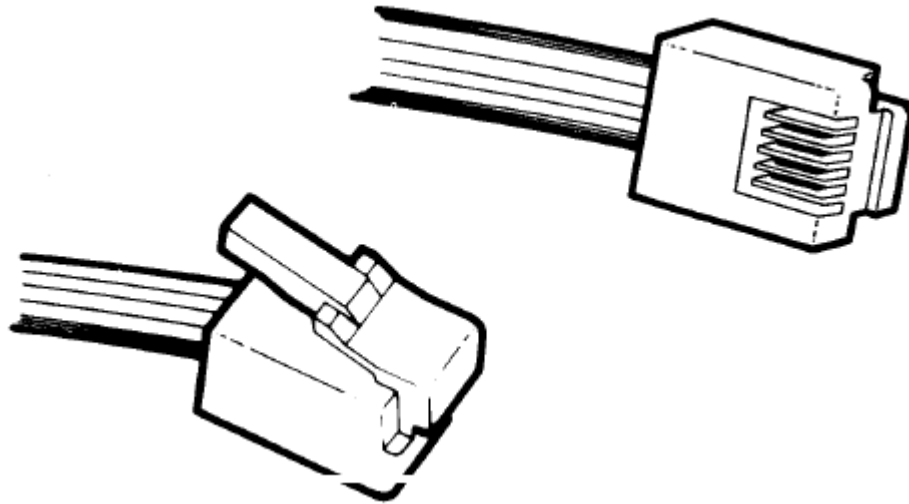

NOTE: This plug is depicted equipped with 4 contacts: it may be fabricated with its full 6 contact capability.

Figure 6.1 View of Miniature 6-Position Plug

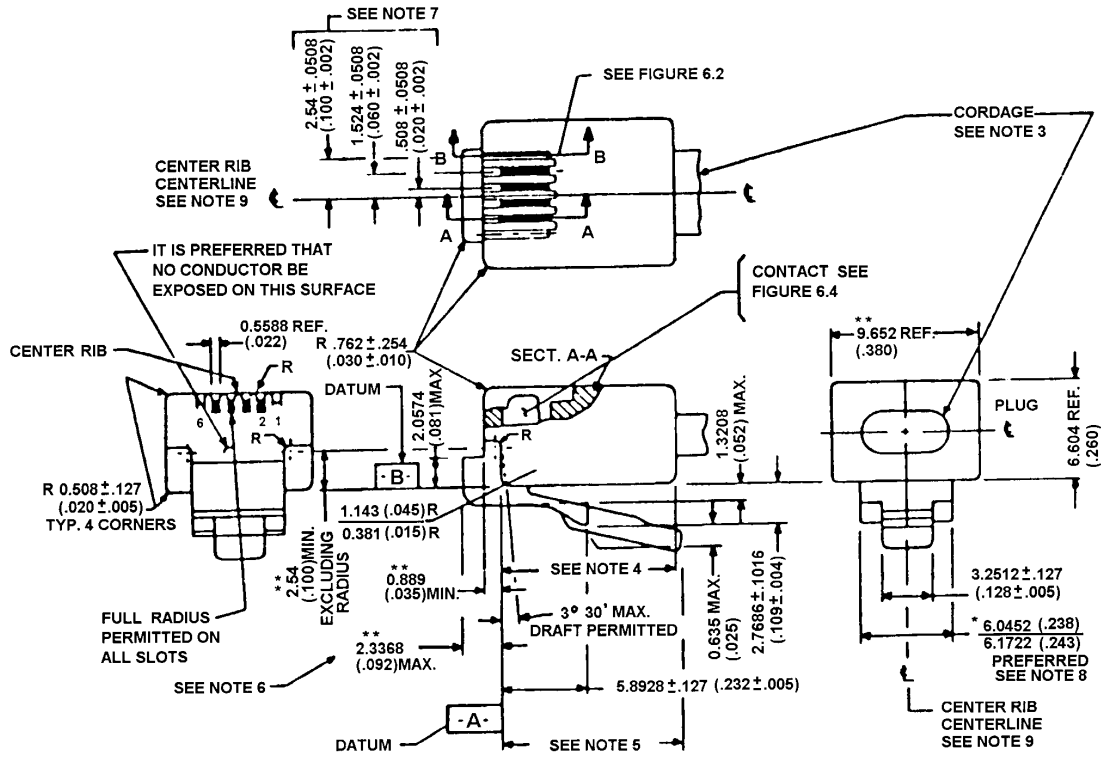

* $\frac{6.0452 (.238)}{6.1722 (.243)}$ DIMENSION TO BE LOCATED CENTRALLY
LOCATED ABOUT CENTER RIB CENTERLINE WITHIN $\pm 0.0762 (\pm .003)$

** SEE GAUGE REQUIREMENTS
FIGURES 6.5 & 6.6

Figure 6.2 6-Position Plug Mechanical Specification

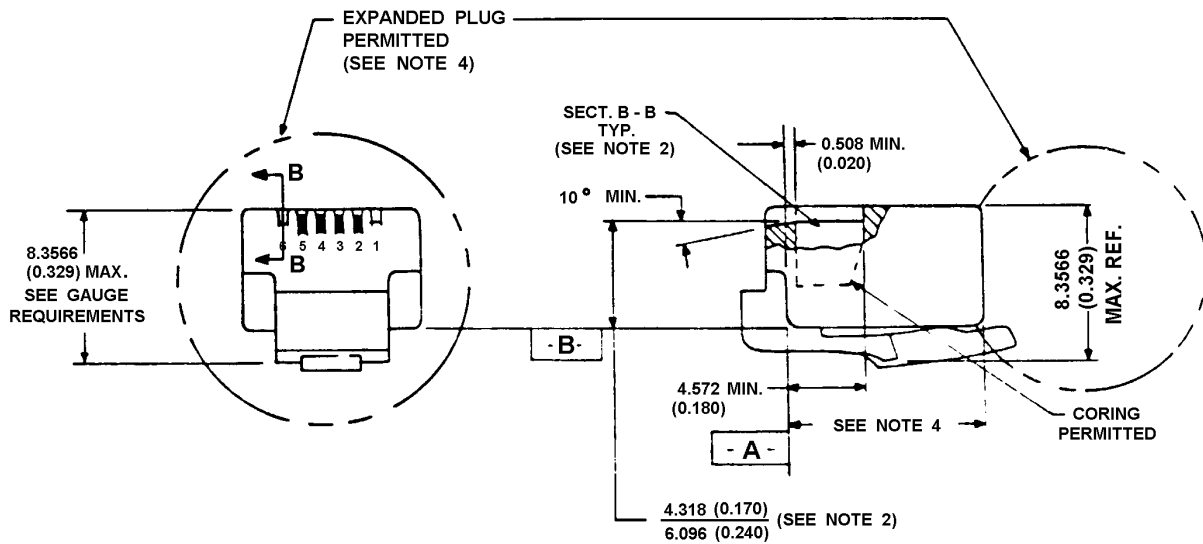
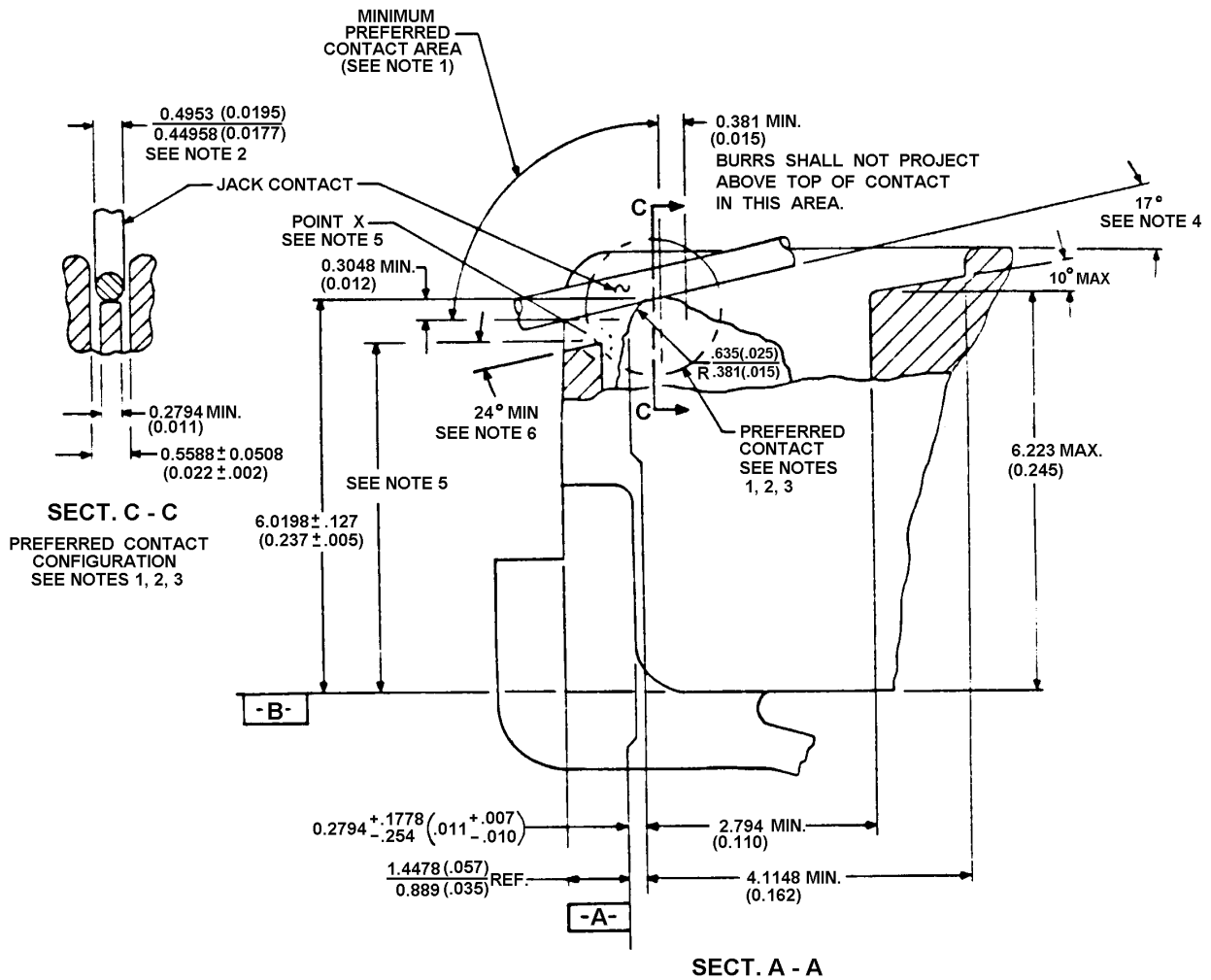

Figure 6.3 6-Position Plug Mechanical Specification (continued)

NOTES to Figures 6.2 and 6.3:

1. All plugs shall be capable of meeting the requirements of the plugs go and no-go gauges.
2. Section BB applies to any jack contact receiving slot that does not contain a plug contact.
3. The major cordage cross section should be 2.5400 mm (0.100 in) max. thick by 5.0800 mm (0.200 in) max. wide, with rounded corners. It should exit the plug on the plug centerline. Other cordage configurations are permitted but may inhibit the special features of some network jack enclosures.
4. The standard plug length shall be 11.6840 mm (0.460 in) max. Plugs may be made longer than standard or adapted for direct use on special cords, adapters with out cordage, and on apparatus or equipment subject to the limitations described in section 6.1.1. Plugs longer than standard could inhibit the special features of some network jack enclosures.
5. A 12.0396 mm (0.474 in) minimum tab length shall be required. A maximum tab length should be no longer than 13.2080 mm (0.520 in). Longer tabs may be used with the same limitations as described in Note 4.
6. To obtain maximum plug guidance when 6-position plugs are inserted in 8-position jacks, the front plug nose should be extended to the 2.3368 mm (0.092 in) maximum.
7. These dimensions shall apply to the location of jack contact receiving slots. Plug contacts should be centered axially in these slots.

8. The 6.0452/6.1722 mm (0.238/0.243 in) dimension normally shall be used to obtain maximum plug guidance in jacks with more than 6 conductors. A tolerance range of 5.9182/6.1722 mm (0.233/0.243 in) is permitted, but could create targeting problems in 8-position jacks.
9. The center rib centerline shall be coincident with the plug width 9.6520 mm (0.380 in) ref. center line within +/- 0.0762 mm (+/- 0.003 in).



NOTE:- THE 8 POSITION PLUG / JACK CONTACT SPECIFICATION IS IDENTICAL

Figure 6.4 6-Position Plug Plug/Jack Contact Specification

NOTES to Figure 6.4:

1. The plug/jack contact interface shall be hard gold to hard gold and shall have a minimum gold thickness of 1.2700 μm (0.050 mil) on each side of the interface. The minimum contact force should be 0.98 N (100 g). Any non-gold contact material shall be compatible with gold and provide equivalent contact performance. A smooth, burr-free surface shall exist at the interface in the area shown.
2. The jack contact design is based upon 0.4572 mm (0.018 in) spring temper phosphor bronze round wire in the modular plug blade and jack contact interface. Other contact configurations that provide contact performance equal to or better than the preferred configurations and do not cause damage to the plug or jack are permitted. The jack contact width should be 0.44958/0.49530 mm (0.0177/0.0195 in). Deviations from the preferred jack contact width are permitted for round contacts as well as noncircular cross sectional shapes but they shall be compatible with existing plug configurations. The requirements of Note 1 shall apply to all possible contact areas.
3. The configuration of the plug contact and the front plastic of the plug shall prevent jack contacts from being damaged during plug insertion into jacks.
4. This nominal contact angle should be provided between plugs and jacks with the plug latched into the jack. This angle shall be less than 24° to avoid loss of electrical contact between the plug and jack. The nominal contact angle shall be greater than 13° to avoid interference between jack contacts and the internal plastic in the plug.
5. To avoid loss of electrical contact, the dimension from datum B to the highest point "X" should be 5.0800 mm (0.200 in) max. A dimension greater than 5.3594 mm (0.211 in) could result in loss of electrical contact between plugs and jacks. The 5.3594 mm (0.211 in) max. shall be considered an absolute maximum.
6. The 24° min. angle applies only to plugs with front plastic walls higher than 4.8260 mm (0.190 in).

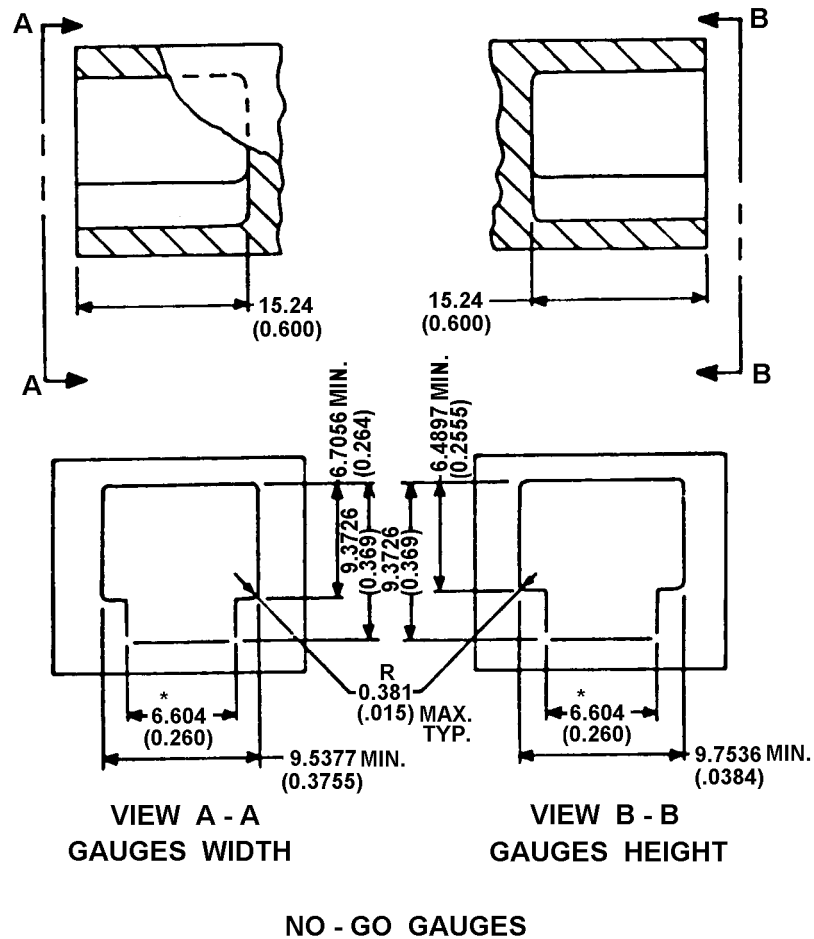

Figure 6.5 6-Position Plug Minimum Plug Size

NOTES:

1. The plug shall not be capable of entering the gauge more than 1.778 mm (0.070) beyond datum-a-(see Figure 6.2) with 8.90 N (2.0 pounds) insertion force.
2. Non-toleranced dimensions given to three places shall be within ± 0.0508 mm (0.002).
3. *6.604 mm (0.260) dimension shall be centrally located with respect to 9.7536 mm (0.384) minimum and 9.5377 mm (0.3755 in) minimum within ± 0.0508 mm (0.002 in).

6.1.1.2 Miniature 6-position jack

6.1.1.2.1 [Reserved]

NOTE: All notes follow Figure 6.8 unless specified

Note :- This jack is depicted with 8 contacts. It may be fabricated with less than 8 contacts.

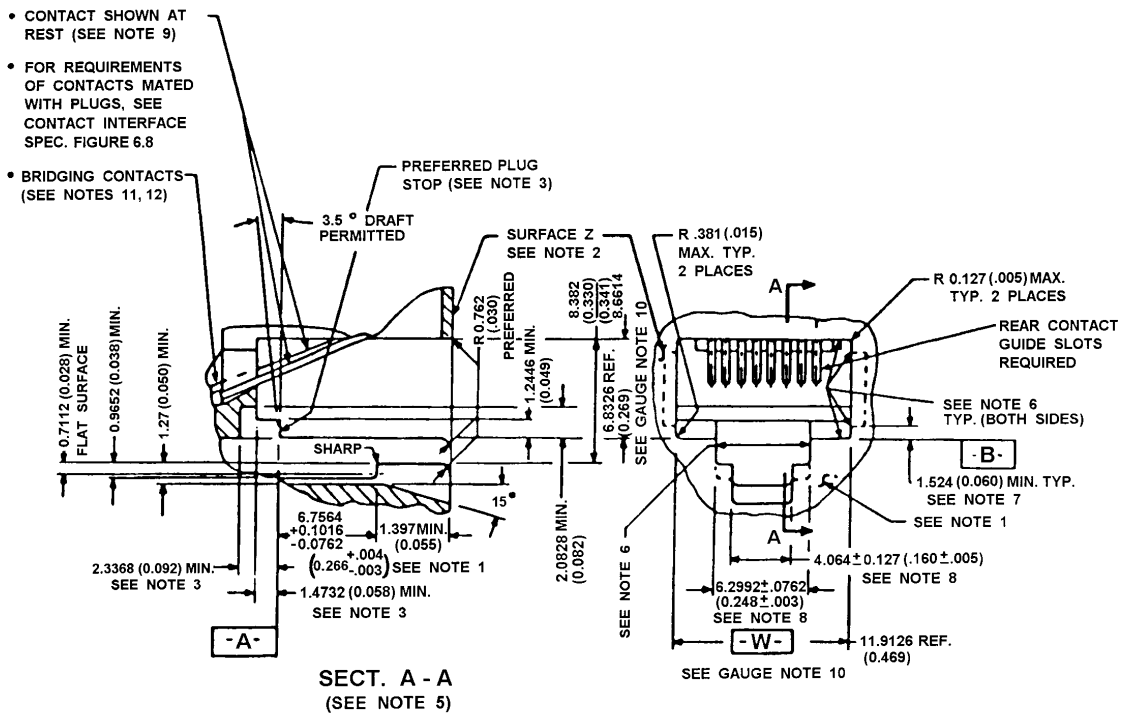

Figure 6.7 6-Position Jack Mechanical Specification

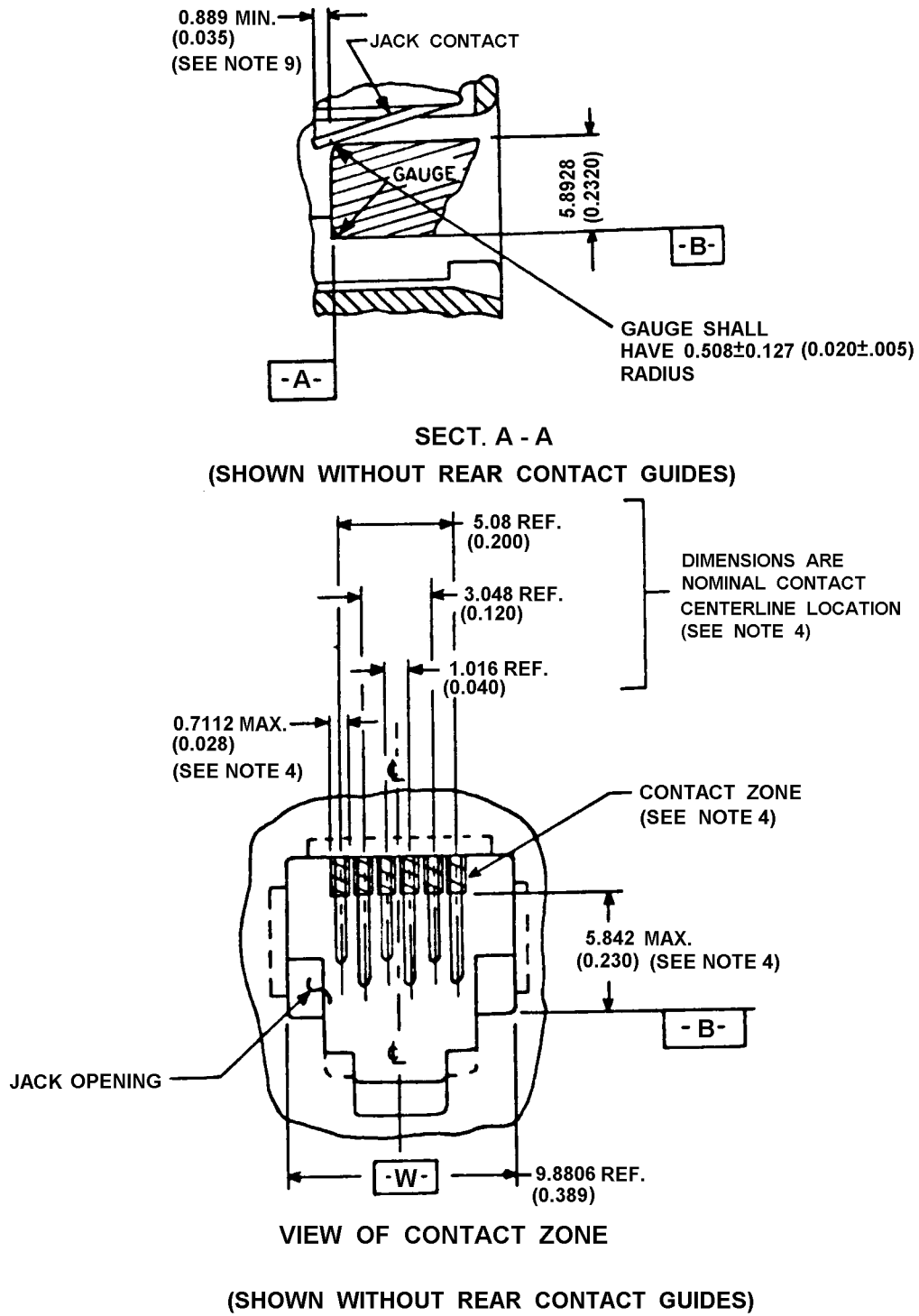

Figure 6.8 6-Position Jack Mechanical Specifications (continued)

NOTES to Figures 6.7 and 6.8:

1. Front surface projections beyond the 1.2700 mm (0.050 in) min. shall be configured so as not to prevent finger access to the plug release catch (Reference Figure 6.12, 6-Position Plug, Mechanical Specifications). A catch length greater than 1.2700 mm (0.050 in) should be used to provide greater breakout strength.
2. Surface Z need not be planar or coincident with the surface under the plug release catch. Surface Z projections shall not prevent insertion, latching, and unlatching of the standard 6-position plug described in section 6.1.1.
3. The indicated plug stop surface should be used. If some other internal feature is used as a plug stop, it shall be located so that the axial movement of a latched plug is no greater than 1.1430 mm (0.045 in).
4. To prevent mistargeting between the plug and jack contacts, the jack contacts shall be completely contained in their individual contact zones, 0.7112 mm (0.028 in) max. wide, where they extend into the jack openings. There is no location requirement for jack contacts below these zones 5.8420 mm (0.230 in) max., but adequate contact separation shall be maintained to prevent electrical breakdown. These shaded contact zones shall be centrally located, (included all locating tolerances), about the jack opening width 9.8806 mm (0.389 in) Ref, (Datum -W-). Contacts located outside of these zones could result in mistargeting between the jack and plug contacts.
5. All inside and outside corners in the plug cavity shall be 0.3810 mm (0.015 in) radius max. unless specified.
6. These surfaces shall have 0°15' maximum draft.
7. Relief inside the dotted areas on 3 sides of the jack opening is permitted. The 6.8326 mm (0.269 in) Ref and 9.8806 mm (0.389 in) Ref Gauge Requirements shall be maintained in each corner, (ref. 1.0160 mm (0.040 in) min), to assure proper plug/jack interface guidance. There shall be a 0.8128 ± 0.1270 mm (0.032 ± 0.005) relief on the top side (opposite plug catch) on jacks in connecting blocks which mount and connect portable wall telephones so as to assure interface with the special purpose sliding modular plug used on many wall telephone sets.
8. 4.0640 mm (0.160 in) and 6.5278/6.8580 mm (0.257/0.270 in) dimensions shall be centrally located to jack opening width -W- within ± 0.1778 mm (± 0.007 in).
9. Minimum acceptable jack contact length. When contact guide slots are used, the contacts shall always be contained inside the guide slots and the contacts shall move freely in the slots so as not to restrain plug insertion or damage jack contacts.
10. Gauge Requirements:

- GO: The jack shall be capable of accepting a 9.7536 mm x 6.7056 mm (0.3840 in x 0.2640 in) gauge and the gauge shall be capable of being removed with a maximum force of 8.9 N (2 pounds).
- NO GO: The jack shall not accept either a 10.00760 mm x 6.45160 mm (0.3940 in x 0.254 in) horizontal width of opening gauge or a 6.95960 mm x 9.5504 mm (0.2740 in x 0.376 in) vertical height of opening gauge. However, if either gauge is accepted the force necessary to remove the gauge shall be minimum 0.83 N (3.0 ounces).
- Removal force requirements shall not include forces contributed by contact springs nor shall external forces be applied to the jack that will affect these removal forces.
- Gauges shall have a 0.7620 mm (0.030 in) radius on the nose and a 0.3810 mm (0.015 in) radius on all edges with clearance provided for contacts.

6.1.1.3 Miniature 8-position plug, unkeyed:

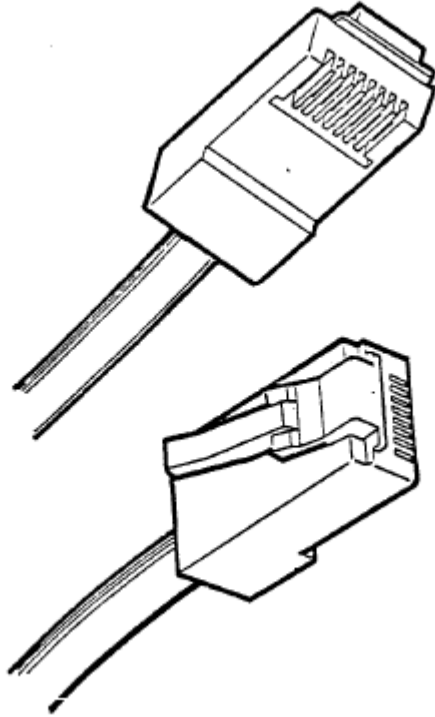

Figure 6.9 View of Miniature 8-Position Plug, Unkeyed

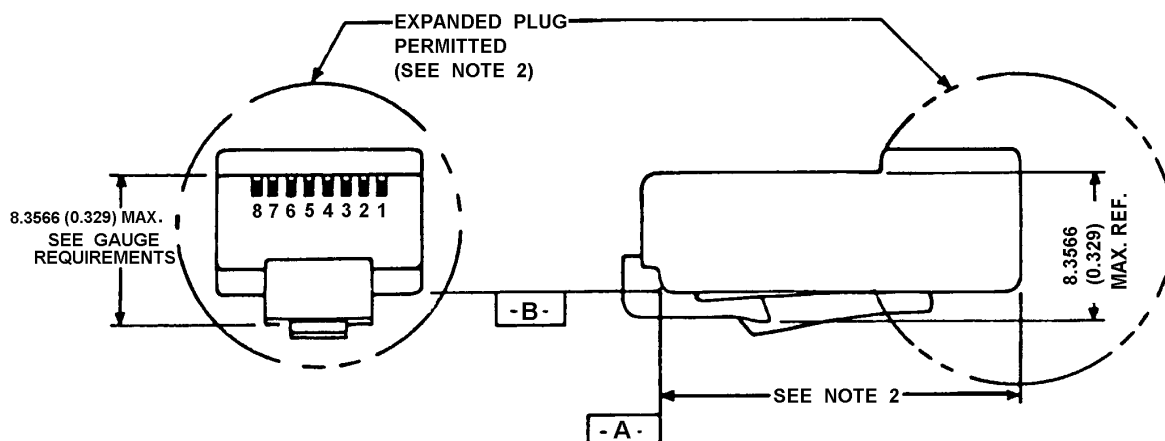
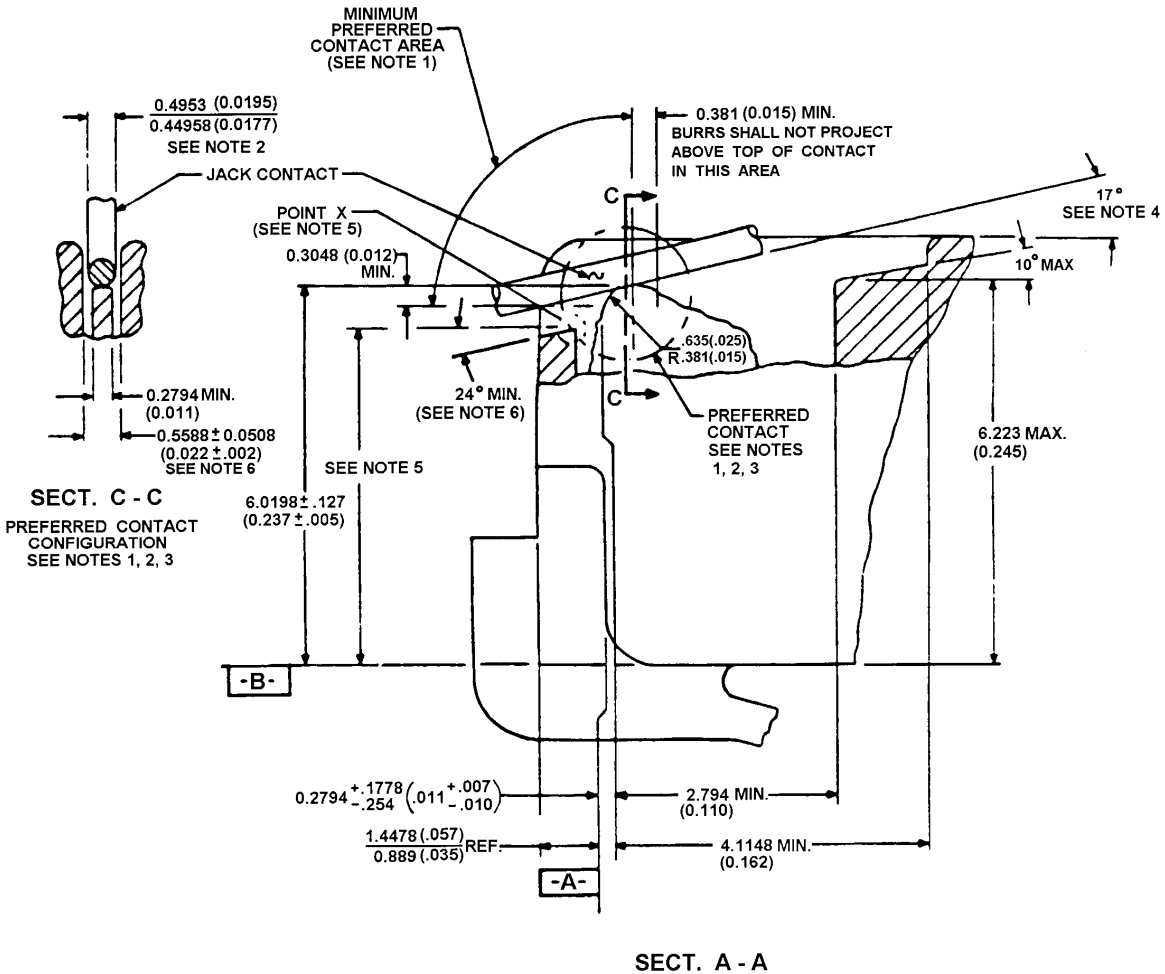

Figure 6.11 8-Position Unkeyed plug, Mechanical Specification (continued)

NOTES for Figures 6.10 and 6.11:

1. All plugs shall be capable of meeting the requirements of the plug go and no-go gauges.
2. The standard plug height in the area shown shall be 8.0010 mm (0.315 in) maximum. The standard plug length shall be 23.1140 mm (0.910 in) maximum. Plugs may be made longer than standard or adapted for direct use on special cords, adapters without cordage, apparatus or equipment subject to the limitations described in the introductory paragraphs of section 6. Plugs longer and/ or higher than standard could inhibit the special features of some network jack enclosures.
3. A 14.6050 mm (0.575 in) minimum tab length shall be provided. The maximum tab length should be no longer than 15.8750 mm (0.625 in). Longer tabs may be used with the same limitations described in Note 2.
4. To obtain maximum plug guidance in jacks, the front plug nose should be extended to the 2.3368 mm (0.092 in) maximum.
5. These dimensions shall apply to the location of jack contact receiving slots. Plug contacts should be centered axially in these slots.

The center rib centerline shall be coincident with the plug width 11.6840 mm ref. (0.460 in ref.) centerline within ± 0.0762 mm (± 0.003 in).



NOTE:- THE 6 POSITION PLUG / JACK CONTACT SPECIFICATION IS IDENTICAL

Figure 6.12 8-Position Unkeyed plug, Plug/Jack Contact Specification

NOTES:

1. The plug/jack contact interface shall be hard gold to hard gold and shall have a minimum gold thickness of 1.2700 μm (0.050 mil) on each side of the interface. The minimum contact force shall be 0.98 N (100 g). Any non-gold contact material shall be compatible with gold and provide equivalent contact performance. A smooth, burr-free surface shall exist at the interface in the area shown.
2. The jack contact design is based upon 0.4572 mm (0.018 in) spring temper phosphor bronze round wire in the modular plug blade and jack contact interface. Other contact configurations that provide contact performance equal to or better than the preferred configurations and do not cause damage to the plug or jack are

permitted. Contact width should be 0.44958/0.49530 mm (0.01777/0.0195 in). Deviations from the desirable jack contact width are permitted for round contacts as well as noncircular cross sectional shapes but they shall be compatible with existing plug configurations. The requirements of Note 1 shall apply to all possible contract areas.

3. The configuration of the plug contact and the front plastic of the plug shall prevent jack contacts from being damaged during plug insertion into jacks.
4. This nominal contact angle should be provided between plugs and jacks with the plug latched into the jack. This angle shall be equal to or less than 24° to avoid loss of electrical contact between the plug and jack. The nominal contact angle shall be equal to or greater than 13° to prevent interference between jack contacts and the internal plastic in the plug.
5. To avoid loss of electrical contact, the dimension from datum B to the highest point "X" should be 5.0800 mm (0.200 in) max. A dimension greater than 5.3594 mm (0.211 in) could result in loss of electrical contact between plugs and jacks. The 5.3594 mm (0.211 in) max. shall be considered an absolute maximum.
6. The 24° min. angle shall apply only to plugs with front plastic walls higher than 4.8260 mm (0.190 in).

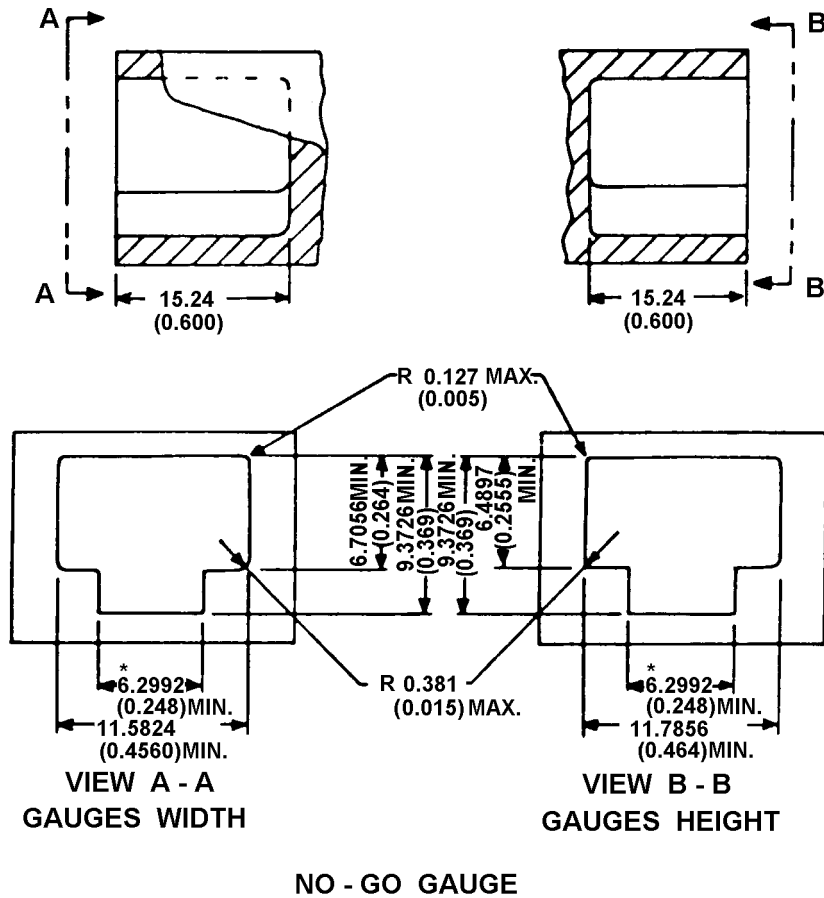

Figure 6.13 8-Position Unkeyed Plug, Minimum Plug Size

NOTES:

1. The plug shall not be capable of entering the gauge more than 1.778 mm (0.070 in) beyond datum-a-(see Figure 6.10) with 8.90 N (2.0 pounds) insertion force.
2. Non-toleranced dimensions given to four places shall be within ± 0.0508 mm (± 0.002 in).
3. *6.2992 mm (0.248 in) dimension shall be centrally located with respect to 11.7856 mm (0.464 in) minimum and 11.58240 mm (0.4560 in) minimum within ± 0.0508 mm (± 0.002 in).

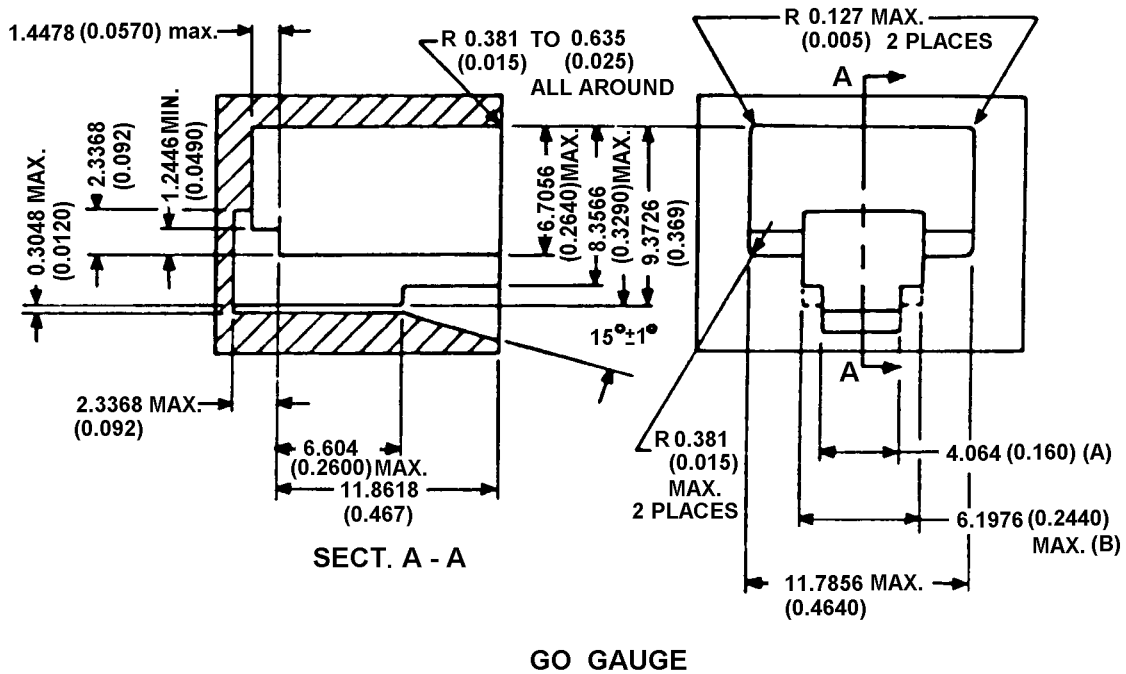

Figure 6.14 8-Position Unkeyed Plug, Maximum Plug Size

NOTES:

1. The plug shall be capable of insertion and latching into the gauge with 22.24 N (5 pounds) or less insertion force. Plug latching bar shall be depressed so as not to interfere with the plug entry. After insertion and latching, plug shall be capable of removal, with the latch depressed, with a removal force of 44.48 N (10 pounds) or less applied at an advantageous angle.
2. Dimensions given to four decimal places shall be within ± 0.0508 mm (0.002).
3. Dimensions (a) and (b) shall be centrally located with respect to 11.7856 mm (0.4640 in) max. Jack opening width within ± 0.0254 mm (0.001 in).
4. Drawings shall not be scaled for external configuration.

6.1.1.4 Miniature 8-position series jack

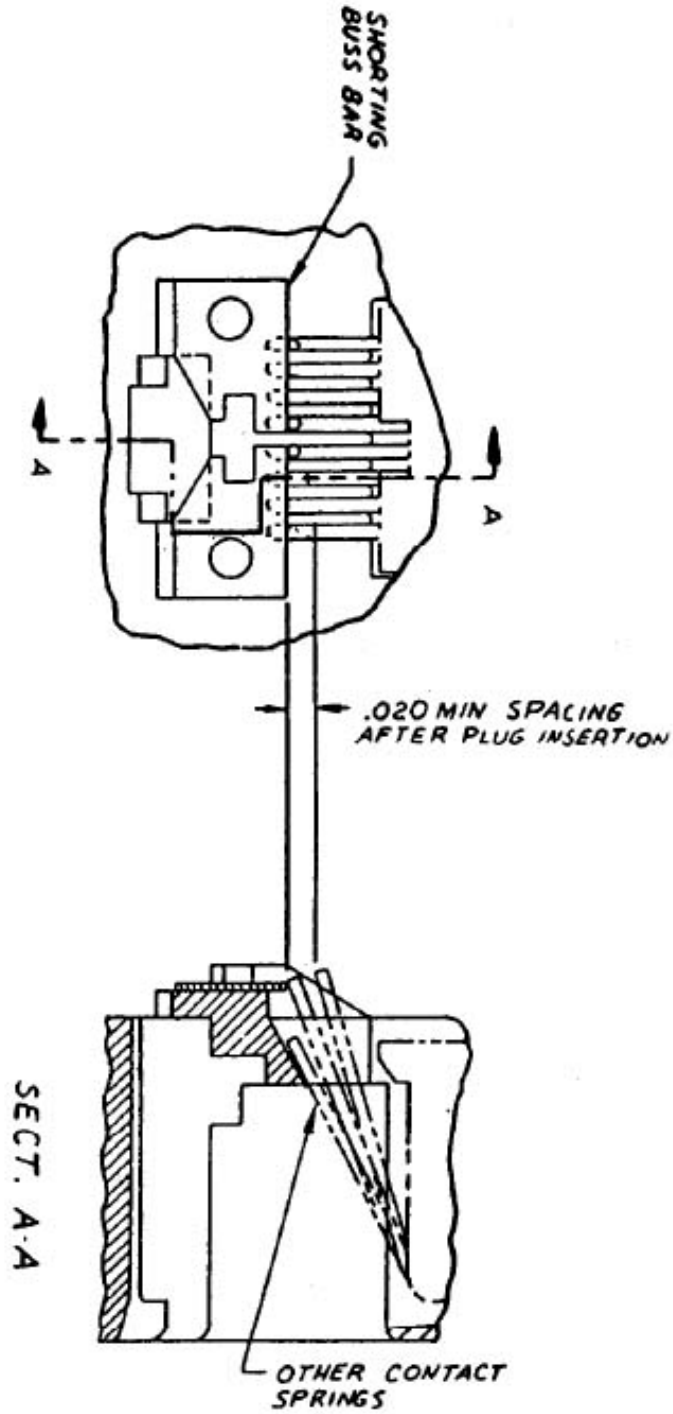

Figure 6.15 8-Position Series Jack, Contact Specification

the axial movement of a latched plug is no greater than 1.1430 mm (0.045 in).

4. To prevent mistargeting between the plug and jack contacts, the jack contacts shall be completely contained in their individual contact zones, (0.7112 mm (0.028 in) max. wide), where they extend into the jack openings. There is no location requirement for jack contacts below these zones (5.8420 mm (0.230 in) max.), but adequate contact separation shall be maintained to prevent electrical breakdown. These shaded contact zones shall be centrally located, (include all locating tolerances), about the jack opening width 11.9126 mm (0.469 in) Ref, (Datum -W-). Contacts located outside of these zones could result in mistargeting between the jack and plug contacts.
5. All inside and outside corners in the plug cavity shall be 0.3810 mm (0.015 in) radius max. unless specified.
6. These surfaces shall have 0°15' maximum draft.
7. Relief inside the dotted areas on both sides of the jack opening is permitted. The 6.8326 mm (0.269 in) Ref and 11.9126 mm (0.469 in) Ref Gauge Requirements shall be maintained in each of the corners indicated, (Ref. 1.5240 mm (0.060 in) min), to assure proper plug/jack interface guidance.
8. 4.0640 mm (0.160 in) and 6.2992 mm (0.248 in) dimensions shall be centrally located to jack opening width -W- within ± 0.1270 mm (0.005 in).
9. The contact lengths shall be such that the contacts will always be contained inside the guide slots, and the contacts shall move freely in the slots so as not to restrain plug insertion or damage jack contacts.
10. Gauge Requirements:
 - GO: The jack shall be capable of accepting an 11.7856 mm x 6.7056 mm (0.4640 in x 0.2640 in) gauge and the gauge shall be capable of being removed with a maximum force of 8.9 N (2.0 pounds).
 - NO GO: The jack shall not accept either a 12.0396 mm x 6.4516 mm (0.4740 in x 0.254 in) horizontal width of opening gauge or a 6.9596 mm x 11.5824 mm (0.2740 in x 0.456 in) vertical height of opening gauge. However, if the gauge is accepted, the force necessary to remove the gauge shall be a minimum of 0.83 N (3.0 ounces).
 - Removal force requirements do not include forces contributed by contact springs nor shall external forces be applied to the jack that will affect these removal forces.
 - Gauges shall have a 0.7620 mm (0.030 in) radius on the nose and a 0.3810 mm (0.015 in) radius on all edges with clearance provided for contacts.
11. With no plug inserted, conductors 1 and 4 shall be bridged as well as conductors 5 and 8. With a miniature 8-position plug inserted into the jack, the bridge connectors shall be broken and a series

connection shall be made in both sides of the line. With a 6-position plug inserted, the bridged connections shall remain unbroken.

12. The jack contact/bridging interface shall be hard gold to hard gold and shall have a minimum gold thickness of 1.2700 μm (0.050 mil) on each side of the interface. The minimum hard gold contact bridging force shall be 0.294 N (30 g). Any non-gold contact material shall be compatible with gold and provide equivalent contact performance.

6.1.1.5 50-position miniature ribbon plug

6.1.1.5.1 Contact finish in the region of contact shall be gold, 0.7620 μm (0.030 mil) minimum thickness, and should be electrodeposited hard gold.¹

6.1.1.5.2 "Datum B" shall be the center line of contact cavities.

6.1.1.5.3 The center line of each contact shall be located within 0.2286 mm (0.009 in) of true position with respect to "Datum B".¹

6.1.1.5.4 Contact width at region of contact shall be (1.143 ± 0.0508) mm (0.04 ± 0.002) in.¹

6.1.1.5.5 Center line of shell dimension indicated shall be within 0.1270 mm (0.005 in) of "Datum B".¹

6.1.1.5.6 Center line of barrier dimension indicated shall be within 0.1270 mm (0.005 in) of "Datum B".¹

6.1.1.5.7 "Surface X" shall have a 0.1016 μm (0.004 mil) finish or better; finishing shall be done in the direction of the arrow.²

6.1.1.5.8 A force of not more than 178 N (40 pounds) shall be sufficient to fully insert the plug onto the sizing gauge shown on Figure 6.18. The plug is fully inserted when "Surface A" of the plug¹ touches "Surface A" of the sizing gauge.

6.1.1.5.9 After one insertion of the plug on the sizing gauge, Figure 6.19, a force of not more than 44.5 N (10 pounds) shall be sufficient to fully insert the plug on the continuity gauge shown in Figure 6.20. The plug is fully inserted on the continuity gauge when "Surface A" of the plug¹ touches "Surface A" of the continuity gauge.

6.1.1.5.10 When the plug is fully inserted on the continuity gauge, Figure 6.20, after having been inserted once on the sizing gauge, Figure 6.19, all contacts of the plug shall electrically contact the continuity gauge as determined by an electrical continuity test which applies an open circuit voltage of not more than 10 Volts. Results greater than 200 Ω indicate test failure.

¹ Figure 6.18.

² Figures 6.19 and 6.20.

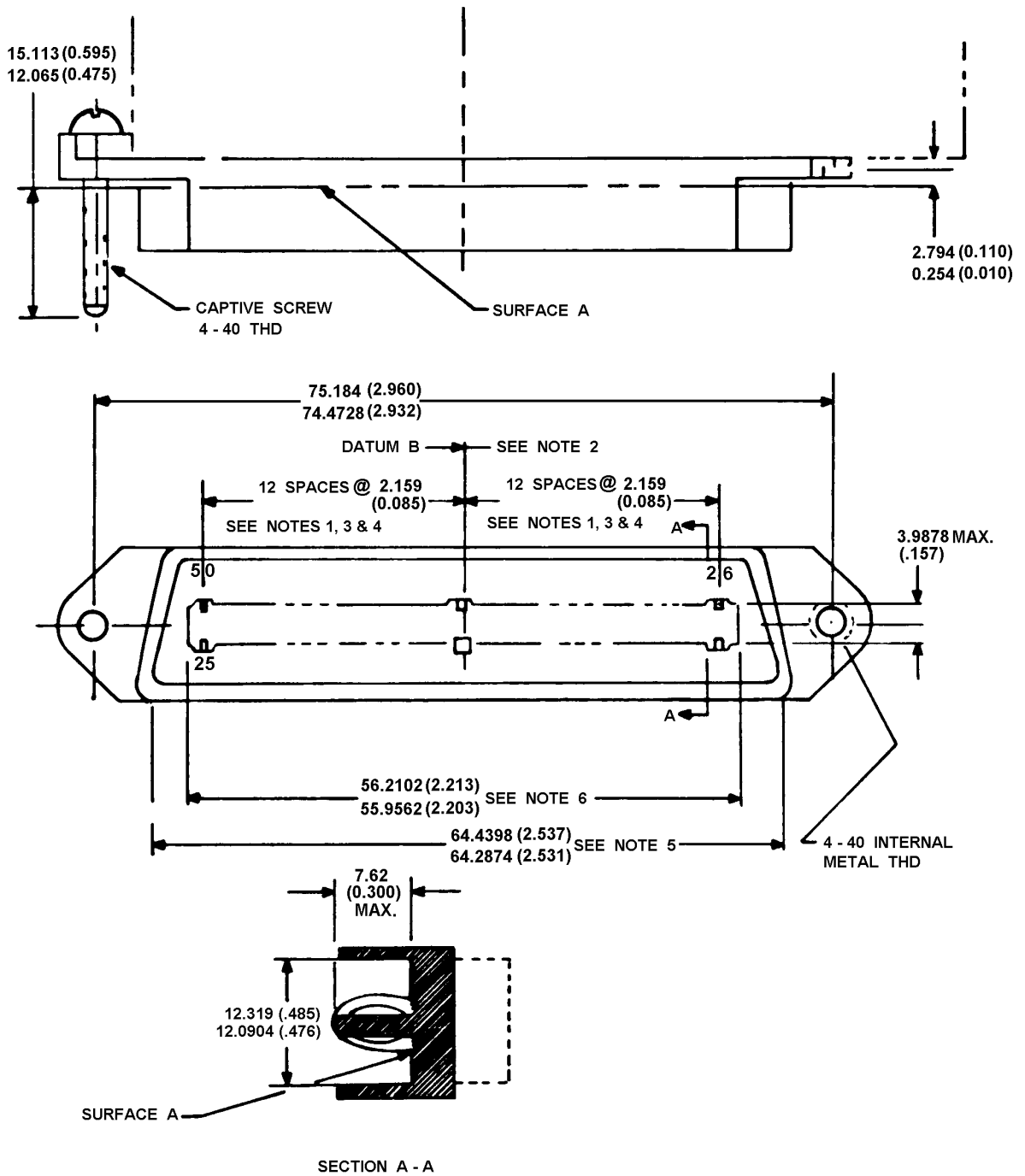

Figure 6.18 50-Position Miniature Ribbon Plug

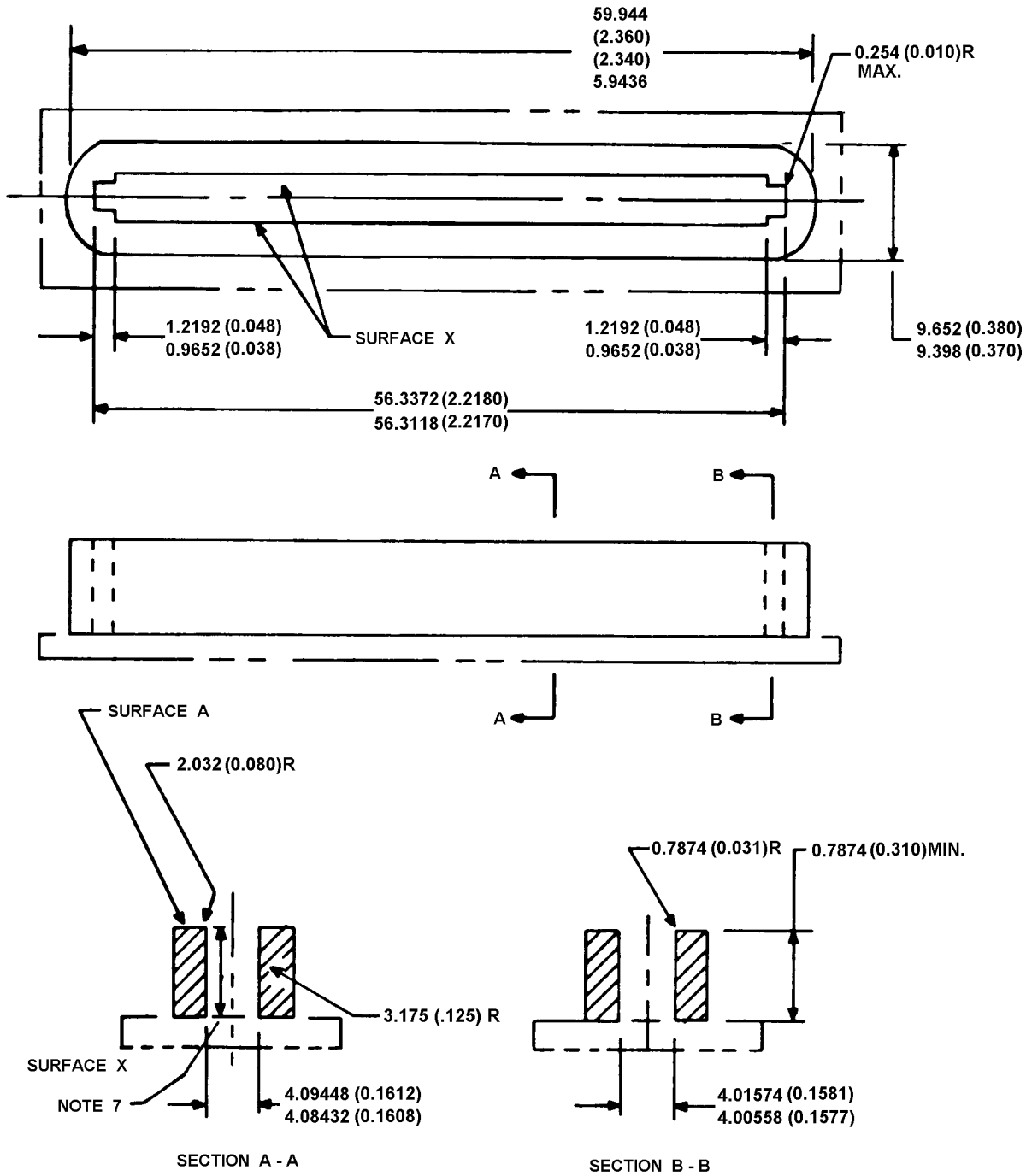

Figure 6.19 50-Position Miniature Ribbon Plug Sizing Gauge

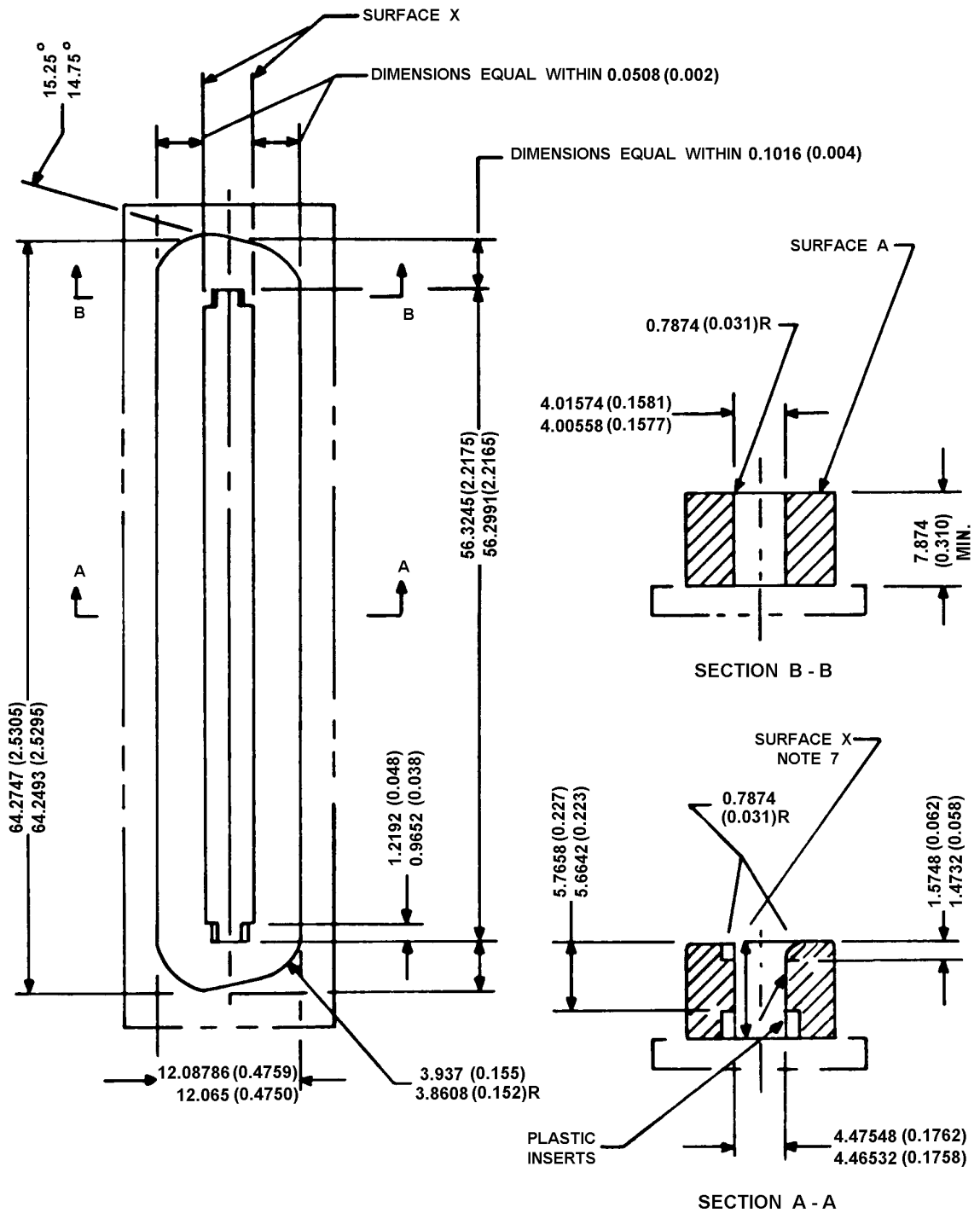

Figure 6.20 50-Position Miniature Ribbon Plug Continuity Gauge

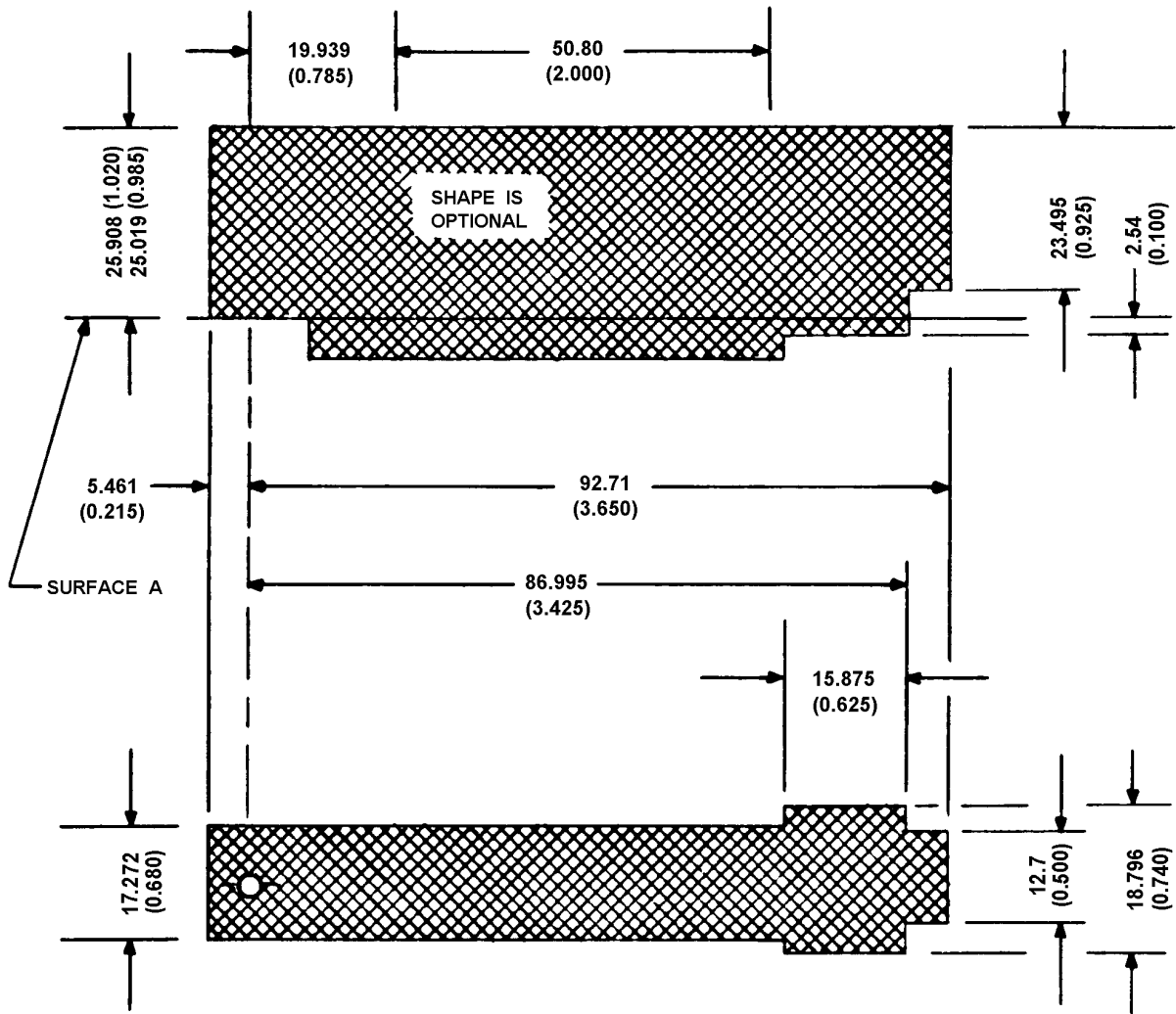

Figure 6.21 50-Position Miniature Ribbon Plug Hood Envelope

6.1.1.6 50-position miniature ribbon jack

6.1.1.6.1 Contact finish in the region of contact shall be gold, 0.7620 μm (0.030 mil) minimum thickness, and should be electrodeposited hard gold.¹

6.1.1.6.2 "Datum B" shall be considered the center line of contact cavities.

6.1.1.6.3 The center line of each contact shall be located within 0.2286 mm (0.009 in) of true position with respect to "Datum B".¹

6.1.1.6.4 Contact width at region of contact shall be 1.1430 ± 0.0508 mm (0.045 ± 0.002 in).¹

6.1.1.6.5 Center line of shell dimension indicated shall be within 0.1270 mm (0.005 in) of Datum B".¹

- 6.1.1.6.6 Center line of cavity dimension indicated shall be within 0.1270 mm (0.005 in) of Datum B".¹
- 6.1.1.6.7 "Surface X" shall have a 0.1016 μm (0.004 mil) finish or better; finishing shall be done in the direction of the arrow.²
- 6.1.1.6.8 A force of not more than 134 N (30 pounds) shall be sufficient to fully insert the jack onto the sizing gauge shown on Figure 6.23. The jack is fully inserted when "Surface A" of the jack ¹ touches "Surface A" of the sizing gauge.
- 6.1.1.6.9 After one insertion of the jack on the sizing gauge, Figure 6.23, a force of not more than 44.5 N (10 pounds) shall be sufficient to fully insert the jack on the continuity gauge shown in Figure 6.24. The jack is fully inserted on the continuity gauge when "Surface A" of the jack ¹ touches "Surface A" of the continuity gauge.
- 6.1.1.6.10 When the jack is fully inserted on the continuity gauge, Figure 6.24, after having been inserted once on the sizing gauge, all contacts of the jack shall electrically contact the continuity gauge as determined by an electrical continuity test which applies an open circuit voltage of not more than 10 volts. Results greater than 200 Ω indicate test failure.

¹ Figure 6.22.

² Figures 6.23 and 6.24.

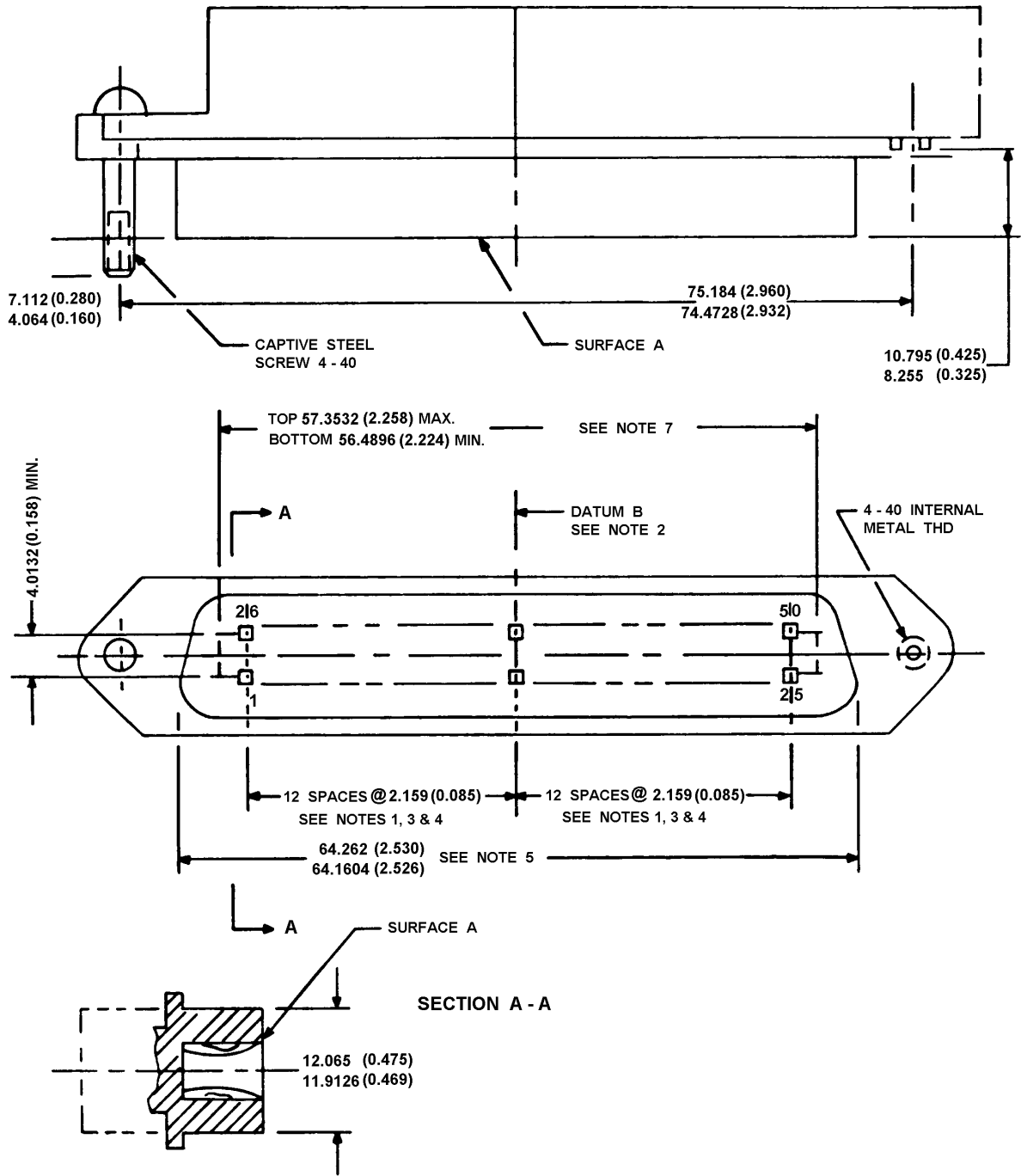

Figure 6.22 50-Position Miniature Ribbon Jack

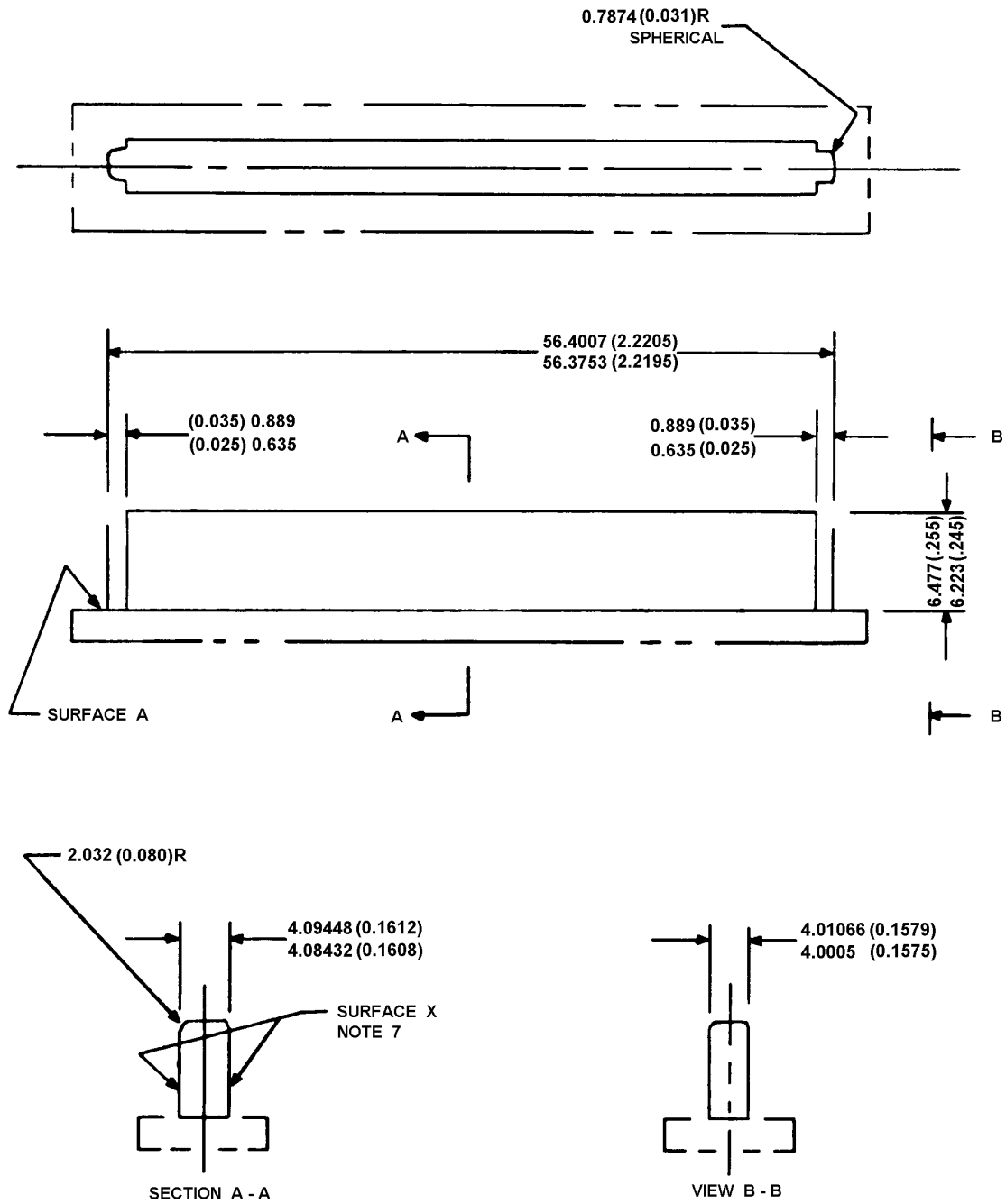

Figure 6.23 50-Position Miniature Ribbon Jack Sizing Gauge

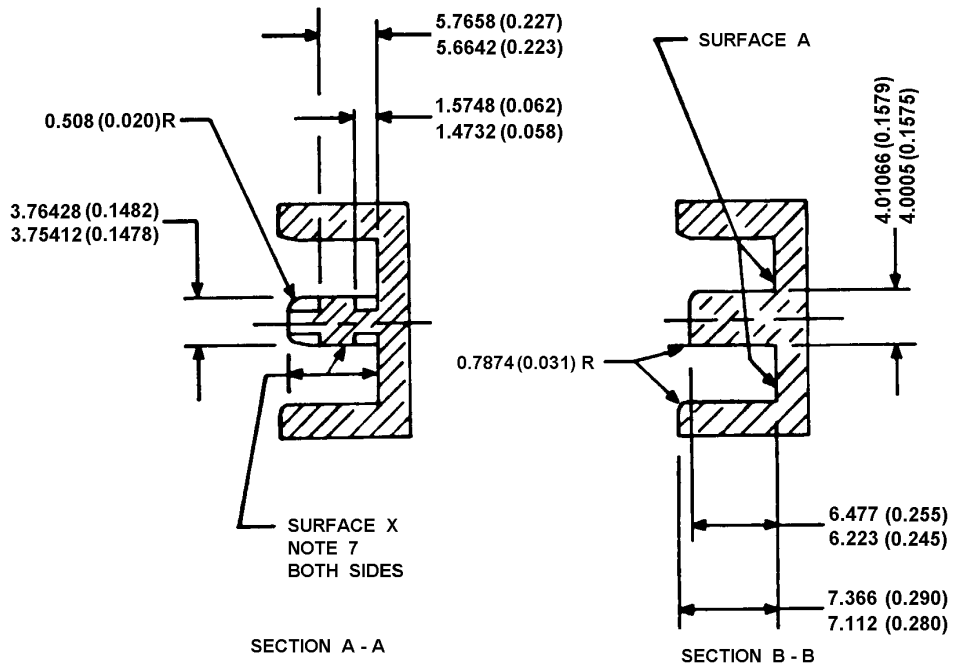
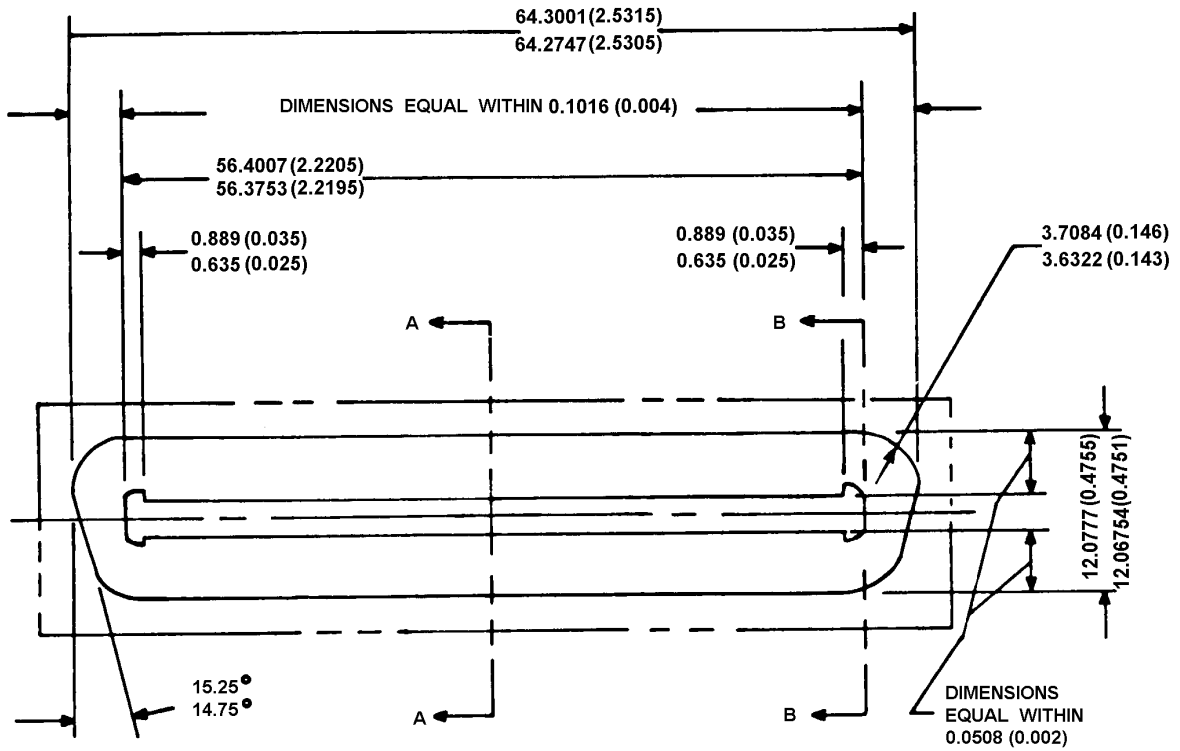

Figure 6.24 50-Position Miniature Ribbon Jack Continuity Gauge

NOTE: All linear dimensions are in mm (inches in parenthesis).

6.1.1.7 3-Position weatherproof plug

Contact blade material shall be brass, with minimum 7.62 μm (0.30 mil) thick nickel plating.

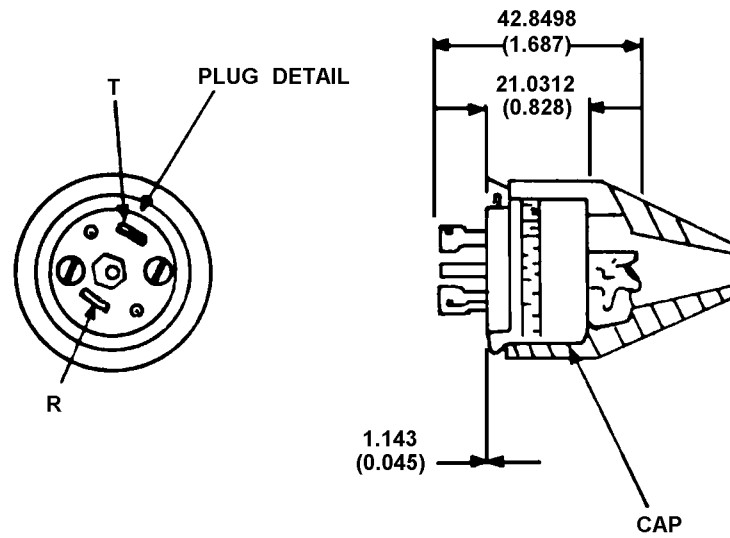

Figure 6.25 3-Position Plug, Plug Assembly

6.1.1.8 3-Position weatherproof jack

Contact blade material shall be brass, with minimum 7.62 mm (0.30 mil) thick nickel plating.

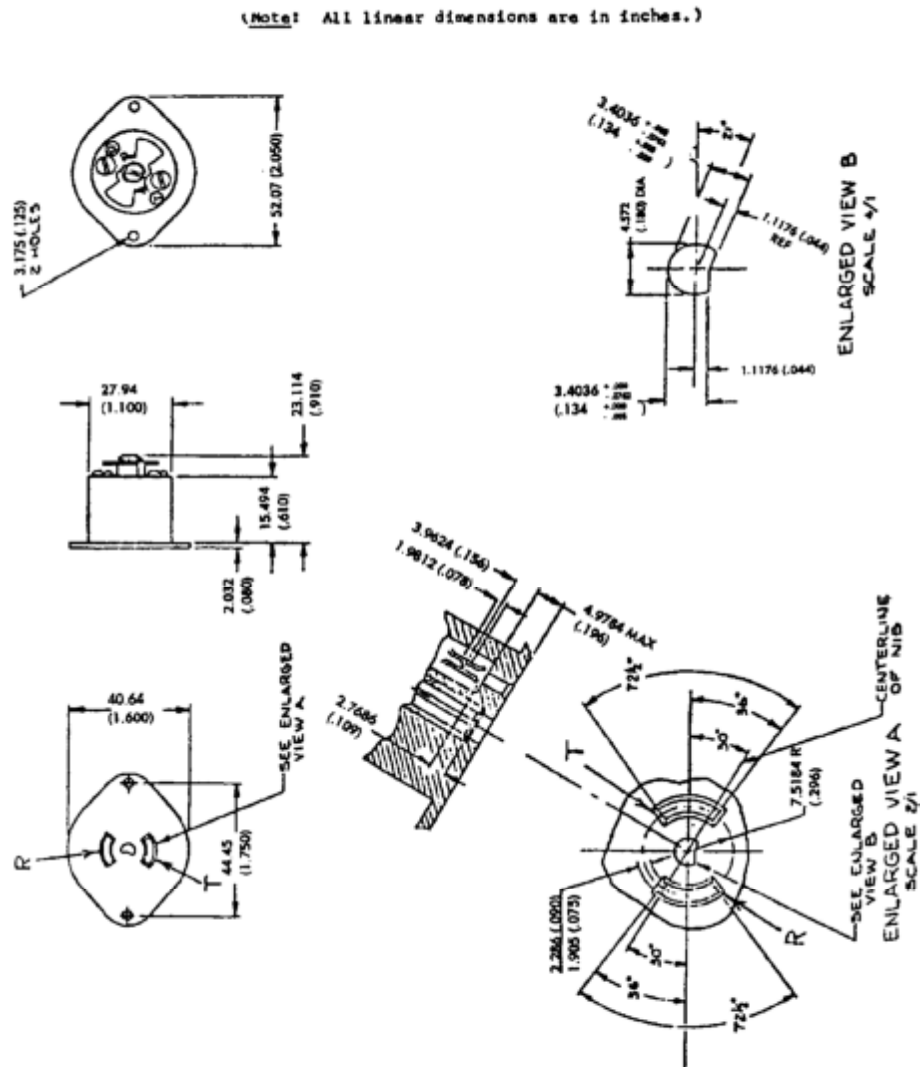

Figure 6. 27 3-Position Plug, Detail

6.1.1.9 Miniature 8-Position plug, keyed

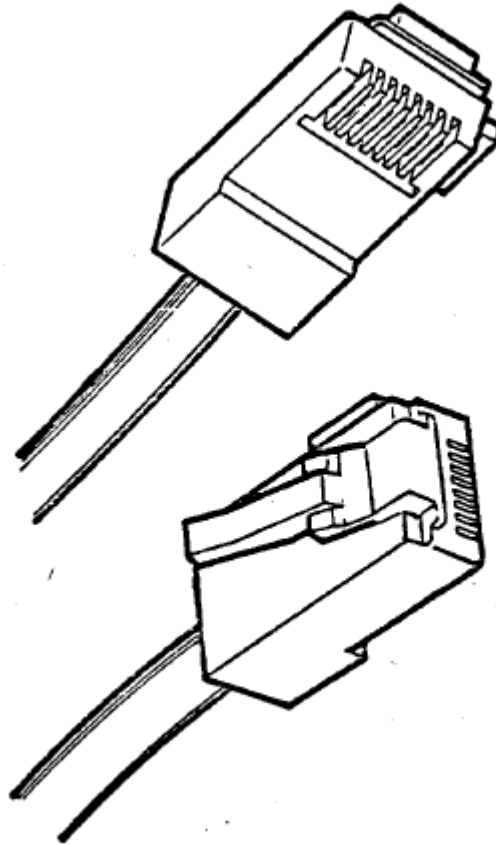
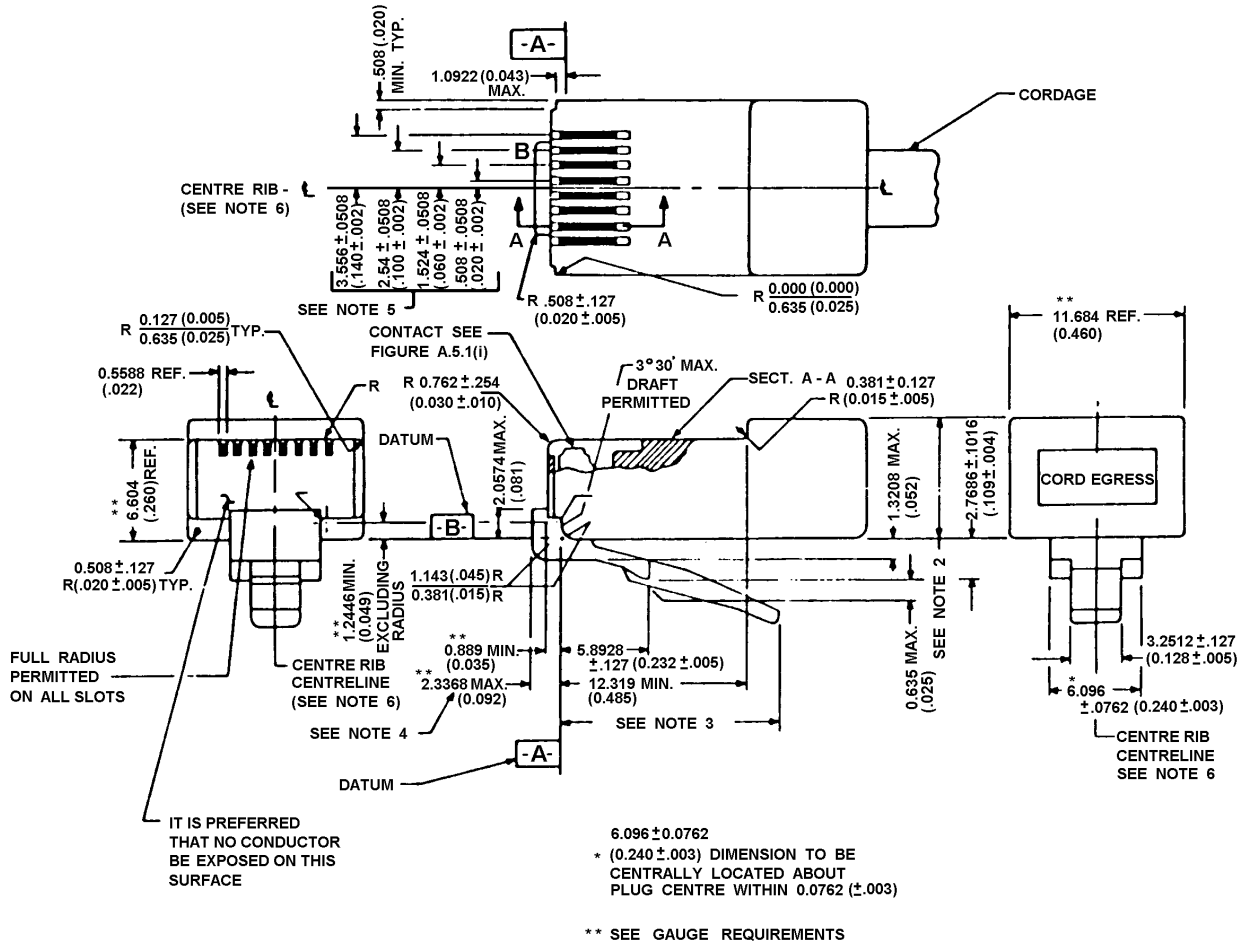

Figure 6.28 View of miniature 8-position plug, keyed

Note :- This plug is depicted with its full 8 contact capacity. It may be fabricated with less than 8 contacts.



NOTE: All notes follow Figure 6.30

Figure 6.29 8-Position Keyed Plug, Mechanical Specification

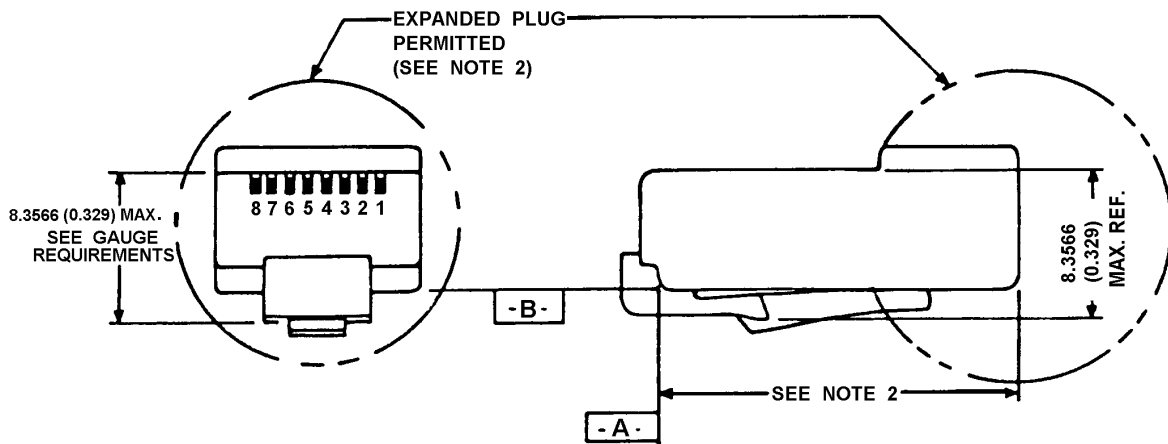
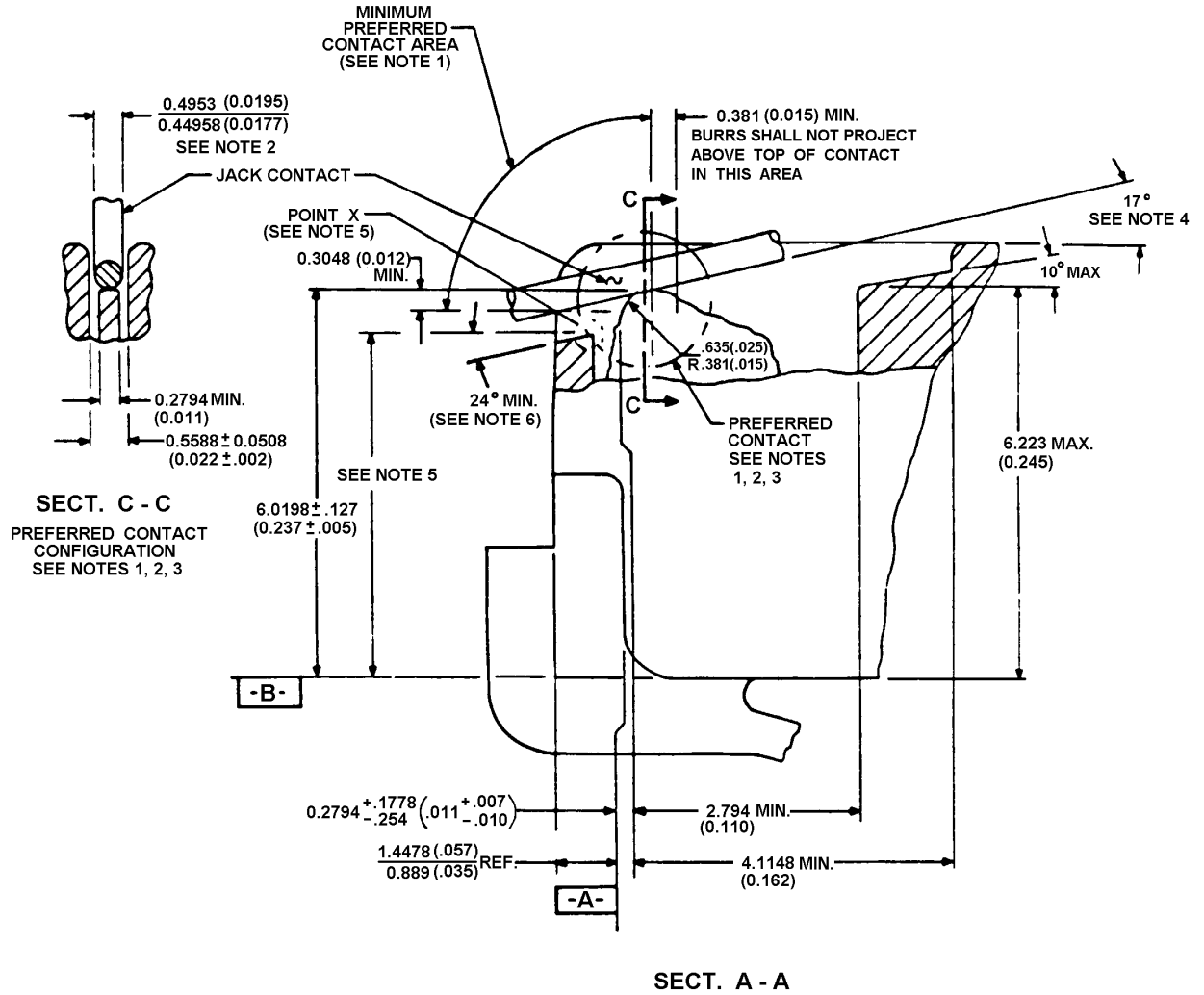

Figure 6.30 8-Position Keyed Plug, Mechanical Specification (continued)

NOTES to Figures 6.29 and 6.30:

1. All plugs shall meet the requirements of the plug go and no-go gauges.
2. The standard plug height in the area shown shall be 8.0010 mm (0.315 in) maximum. The standard plug length shall be 23.1140 mm (0.910 in) maximum. Plugs may be made longer than standard or adapted for direct use on special cords, adapters without cordage, apparatus or equipment subject to the limitations described in section 6.1.1. Plugs longer and/ or higher than standard could inhibit the special features of some network jack enclosures.
3. The minimum tab length shall be 14.6050 mm (0.575 in). The maximum tab length normally shall be no longer than 15.8750 mm (0.625 in). Longer tabs may be used with the limitations described in Note 2.
4. To obtain maximum plug guidance in jacks, the front plug nose should be extended to the 2.3368 mm (0.092 in) maximum.
5. These dimensions apply to the location of jack contact receiving slots. Plug contacts should be centered axially in these slots.
6. The center rib centerline shall be coincident with the plug width, 11.6840 mm ref (0.460 in ref.) center line within $\pm 0.0762\text{mm}$ (± 0.003 in)



NOTE:- THE 6 POSITION PLUG / JACK CONTACT SPECIFICATION IS IDENTICAL

Figure 6.31 8-Position Keyed Plug, Plug/Jack Contact Specification

NOTES to Figure 6.31:

1. The plug/jack contact interface shall be hard gold to hard gold and shall have a minimum gold thickness of 1.2700 μm (0.050 mil) on each side of the interface. The minimum contact force shall be 0.98 N (100 g). Any non-gold contact material shall be compatible with gold and provide equivalent contact performance. A smooth, burr-free surface shall exist at the inter-face in the area shown.
2. The jack contact design is based upon 0.4572 mm (0.018 in) spring temper phosphor bronze round wire in the modular plug blade and jack contact interface. Other contact configurations that provide contact performance equal to or better than the preferred configurations and do not cause damage to the plug or jack may be provided. The jack contact width normally shall be 0.44958/0.49530 mm (0.0177/0.0195 in). Deviations from the preferred jack contact width are permitted for round contacts as well as noncircular cross sectional shapes but such deviations shall be compatible with existing plug configurations. The requirements of Note 1 shall apply to all possible contact areas.
3. The configuration of the plug contact and the front plastic of the plug shall prevent jack contacts from being damaged during plug insertion into jacks.
4. This should be the nominal contact angle between plugs and jacks with the plug latched into the jack. This angle shall be equal to or less than 24° to avoid loss of electrical contact between the plug and jack. The nominal contact angle shall be equal to or greater than 13° to avoid interference between jack contacts and the internal plastic in the plug.
5. To avoid loss of electrical contact, the dimension from "Datum B" to the highest point "X" should be 5.0800 mm (0.200 in) max. A dimension greater than 5.3594 mm (0.211 in) could result in loss of electrical contact between plugs and jacks. The 5.3594 mm (0.211 in) max. shall be considered an absolute maximum.
6. The 25° min. angle shall apply only to plugs with front plastic walls higher than 4.8260 mm (0.190 in).

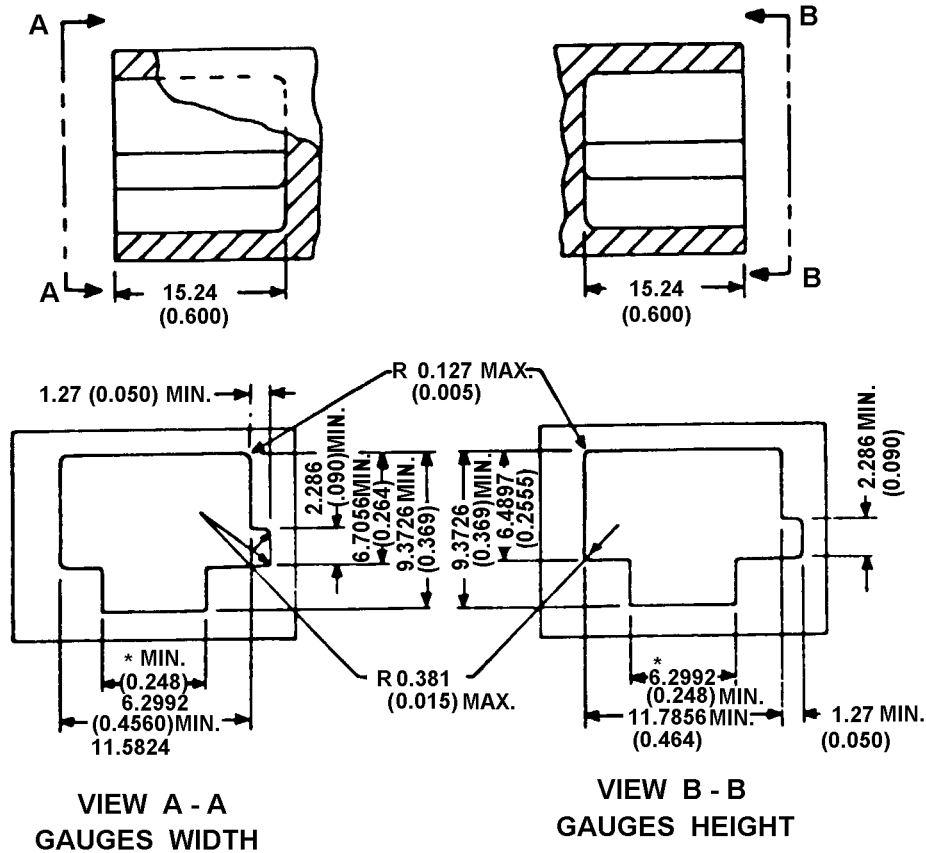

NO - GO GAUGE

Figure 6.33 8-Position Keyed Plug, Minimum Plug Size

NOTES:

1. The plug shall not enter the gauge more than 1.778 mm (0.070 in) beyond datum-a- (see Figure 6.29 with 8.90 N (2.0 pounds) insertion force).
2. Non-toleranced dimensions given to three places shall be within ± 0.0508 mm (± 0.002).
3. *6.2992 mm (0.248 in) dimension shall be centrally located with respect to 11.7856 mm (0.464 in) minimum and 11.5824 mm (0.4560 in) minimum within ± 0.0508 mm (0.002 in).

6.1.1.10 Miniature 8-position keyed jack

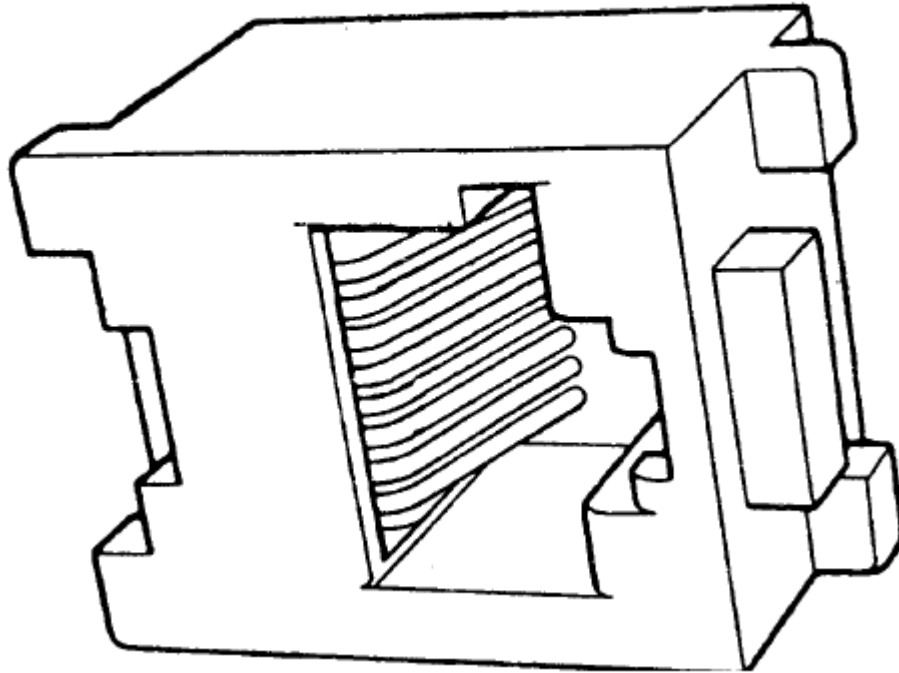

Figure 6.34 View of Miniature 8-Position Keyed Jack

Note :- This jack is depicted with 8 contacts. It may be fabricated with less than 8 contacts.

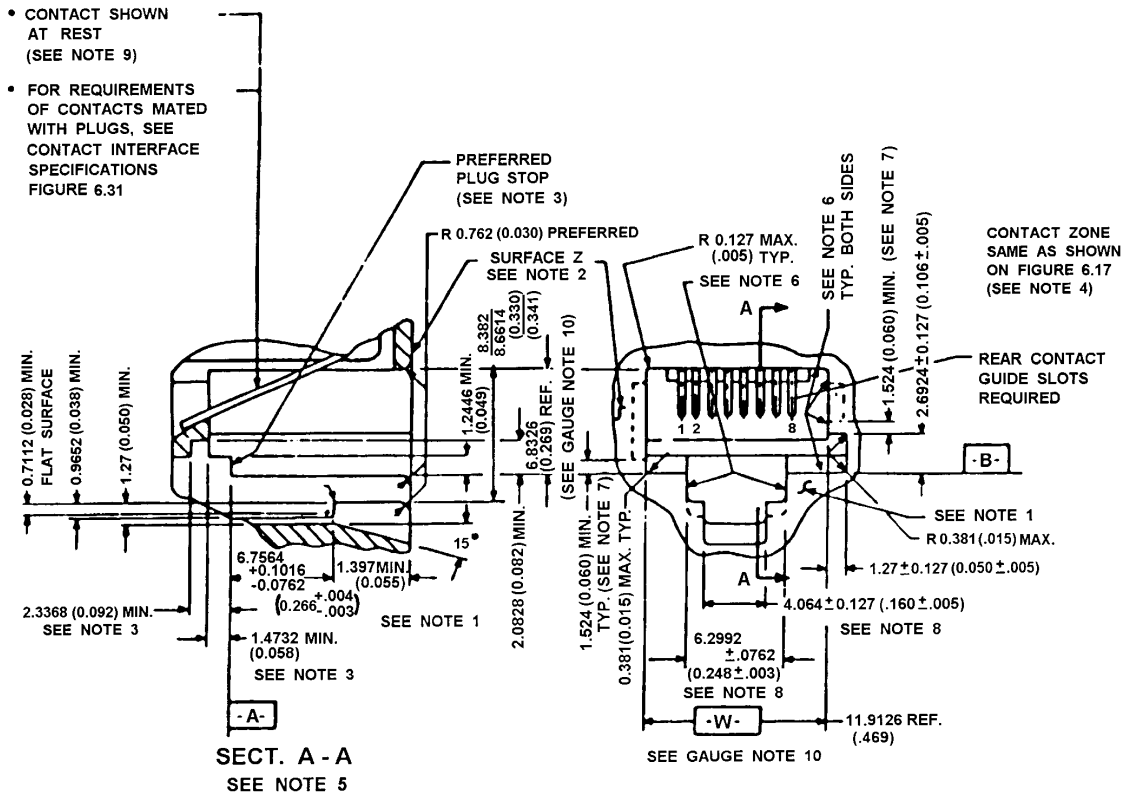

Figure 6.35 8-Position Keyed Jack, Mechanical Specification

NOTES to Figure 6.35:

1. Front surface projections beyond the 1.3970 mm (0.055 in) minimum shall be configured so as not to prevent finger access to the plug release catch (Reference Figure 6.30 and 8-Position Plug, Mechanical Specifications). A catch length should be greater than 1.3970 mm (0.055 in) to provide greater breakout strength and improved guidance when interfacing with a 6-position plug.
2. Surface Z need not be planar or coincident with the surface under the plug release catch. Surface Z projections shall not prevent insertion, latching, and unlatching of the standard 8-position plug on Figure 6.29.
3. The indicated plug stop surface should be provided. If some other internal feature is used as a plug stop, it shall be located so that the axial movement of a latched plug is no greater than 1.1430

mm (0.045) in.

4. To prevent mistargeting between the plug and jack contacts, the jack contacts shall be completely contained in their individual contact zones 0.7112 mm (0.028 in) max wide, where they extend into the jack openings. There is no location requirement for jack contacts below these zones (5.8420 mm (0.230 in) max), but adequate contact separation shall be maintained to prevent electrical breakdown. These shaded contact zones shall be centrally located, (include all locating tolerances), about the jack opening width 11.9126 mm (0.469 in) Ref, (Datum–W–). Contacts located outside of these zones could result in mistargeting between the jack and plug contacts.
5. All inside and outside corners in the plug cavity shall be 0.3810 mm (0.015 in) radius max unless specified.
6. These surfaces shall have 0°15' maximum draft.
7. Relief inside the dotted areas on both sides of the jack opening shall be permitted. The 6.8326 mm (0.269 in) Ref and 11.9126 mm (0.469 in) Ref Gauge Requirements shall be maintained in each of the corners indicated, (Ref. 1.5240 mm (0.060 in) min), to assure proper plug/jack interface guidance.
8. 4.0640 mm (0.160 in) and 6.2992 mm (0.248 in) dimensions shall be centrally located to jack opening width –W– within ± 0.1270 mm (± 0.005 in).
9. The contact lengths shall be such that the contacts will always be contained inside the guide slots and the contacts shall move freely in the slots so as not to restrain plug insertion or damage jack contacts.
10. Gauge Requirements:
 - GO: The jack shall be capable of accepting an 11.78560 x 6.70560 mm (0.4640 x 0.2640 in) gauge and the gauge shall be capable of being removed with a maximum force of 8.9 N (2.0 pounds).
 - NO GO: The jack shall not accept either a 12.03960 x 6.4516 mm (0.4740 x 0.254 in) horizontal width of opening gauge or a 6.95960 x 11.5824 mm (0.2740 x 0.456 in) vertical height of opening gauge. However, if the gauge is accepted, the force necessary to remove the gauge shall be a minimum of 0.83 N (3.0 ounces).
 - Removal forces shall not include forces contributed by contact springs nor shall external forces be applied to the jack that will affect these removal forces.
 - Gauges shall have a 0.7620 mm (0.030 in) radius on the nose and a 0.3810 mm (0.015 in) radius on all edges with clearance provided for contracts.

6.2 WIRING CONFIGURATIONS

The connectors specified in this standard shall be wired in accordance with any of the applicable wiring configurations provided in T1.TR.5-1999. The applicable connector and connector wiring configuration for approved TE shall be identified in consumer instructions and product approval documentation.

6.2.1 Universal Service Ordering Code

A Universal Service Ordering Code (USOC) is specified in T1.TR5-1999 for each wiring configuration. These USOCs are generic service ordering codes that are used or recognized by most wireline carriers. If a customer wishes to have the wireline carrier install a jack or wiring configuration, the appropriate USOC needs to be specified when the customer requests service installation.

6.2.2 Default Connector Wiring Configuration

In the absence of a request for a specific type of jack and wiring configuration, wireline carriers will typically install a 6-position non-keyed jack with the RJ11W (for wall mounted equipment) or RJ11C (for all other equipment) wiring configuration shown in Figure 6-36.

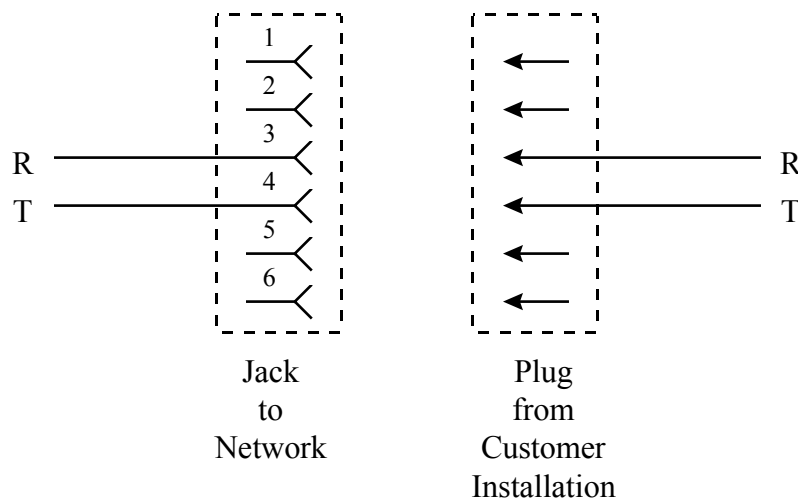

Figure 6-36 – RJ11C/W Network Interface Wiring Configuration

6.3 CONFIGURATIONS USED TO CONNECT MULTI-LINE COMMUNICATIONS SYSTEMS SUCH AS PRIVATE BRANCH EXCHANGE (PBX) AND KEY TELEPHONE SYSTEMS

Any of the jack configurations specified in section 6.2, used singly, in multiple combinations, or combined in common mechanical arrays, may be used as the interface between multi-line equipment such as PBX and key telephone systems, and the telephone network. The telephone company and installation supervisor may mutually agree to use electrical

connections alternative to those specified in section 6.2.

Annex A (normative)

Grandfathered Terminal Equipment (normative)

A.1 Introduction

This annex identifies terminal equipment (TE) that has been grandfathered by FCC action and identifies the conditions under which such TE may be connected to the public switched telephone network and services without approval.

A.2 Grandfathered terminal equipment (other than PBX and key telephone systems) and protective circuitry.

All terminal equipment (other than PBX and key telephone systems) and protective circuitry of a type directly connected to the public switched telephone network and services identified in 1.1(b) as of October 17, 1977, may be connected thereafter up to July 1, 1979—and may remain connected for life—without approval unless subsequently modified.

A.3 Grandfathered systems (including, but not limited to, PBX and key telephone systems).

- a) Entire systems, including their equipment, premises wiring, and protective apparatus (if any) directly connected to the public switched telephone network and services identified in 1.1(b) on June 1, 1978, may remain connected to the public switched telephone network and services identified in 1.1(b) for life without approval, unless subsequently modified, except for modifications allowed under A.3(c).
- b) New installations of equipments may be performed (including additions to existing systems) up to January 1, 1980, without approval of any equipments involved, provided that these equipments are of a type directly connected to the public switched telephone network or services identified in 1.1(b) as of June 1, 1978. These equipments may remain connected to the public switched telephone network or services identified in 1.1(b) for life without approval, unless subsequently modified, except for modifications allowed under A.3(c).
- c) Modifications to systems and installations involving unapproved equipment:
 - 1) Use of other than fully-protected premises wiring is a modification under 1.1. As an exception to the general requirement that no modification is permitted to unapproved equipment whose use is permitted under 1.1, certain modifications are authorized here-in.
 - 2) Other than fully-protected premises wiring may be used if it is qualified in accordance with the procedures and requirements of § 68.215. Since there is no “responsible party” of unapproved equipment, the training and authority required by § 68.215(c) will have to be received from the equipment’s manufacturer.

- 3) Existing separate, identifiable and discrete protective apparatus may be removed, or replaced with apparatus of lesser protective function, provided that any premises wiring to which the public switched telephone network or service identified in 1.1 is thereby exposed conforms to A.3(c)(2) above. Minor modifications to existing unapproved equipments are authorized to facilitate installation or premises wiring, so long as they are performed under the responsible supervision and control of a person who complies with § 68.215(c). Since there is no “responsible party” of unapproved equipment, the training and authority required by § 68.215(c) will have to be received from the manufacturer of the equipment so modified.

A.4 Grandfathered private branch exchange (or similar) systems for connection to private line type services (tie trunk type services, off-premises station lines, automatic identified outward dialing, and message registration):

- a) PBX (or similar) systems, including their equipments, premises wiring, and protective apparatus (if any) directly connected to a private line type service on April 30, 1980 may remain connected to the private line type service for life without approval unless subsequently modified, except for modifications allowed under A.4(c).
- b) New installations of equipments may be performed (including additions to existing systems) up to May 1, 1983 without approval of any equipments involved, provided that these equipments are of a type directly connected to a private line type service as of April 30, 1980. These equipments may remain connected to the private line type service for life without approval, unless subsequently modified, except for modifications allowed under A.4(c).
- c) Modifications to systems and installations involving unapproved equipment:
 - 1) Use of other than fully-protected premises wiring is a modification under 1.1. As an exception to the general requirement that no modification is permitted to unapproved equipment whose use is permitted under 1.1, certain modifications are authorized here-in.
 - 2) Other than fully-protected premises wiring may be used if it is qualified in accordance with the procedures and requirements of § 68.215. Since there is no “responsible party” of unapproved equipment, the training and authority required by § 68.215(c) will have to be received from the equipment’s manufacturer.
 - 3) Existing separate, identifiable and discrete protective apparatus may be removed, or replaced with apparatus of lesser protective function, provided that any premises wiring to which the private line type service is thereby exposed conforms to A.4(c)(2) above. Minor modifications to existing unapproved equipments are authorized to facilitate installation or premises wiring, so long as they are performed under the responsible supervision and control of a person who complies with § 68.215(c). Since there is no “responsible party” of unapproved equipment, the training and authority required by § 68.215(c) will have to be received from the manufacturer of the equipment so modified.

- d) PBX (or similar) systems connected with automatic identified outward dialing or message registered private line services of a type that complies with paragraphs A.4(3)(a) and A.4.(3)(b) of this section may remain connected for life without approval unless subsequently modified.

A.5 Grandfathered terminal equipment for connection to local area data channels.

All terminal equipment of a type directly connected to Local Area Data Channels or directly connected under special assembly tariff provisions to telephone company-supplied, non-loaded, metallic, greater-than-voiceband circuits for the purpose of providing limited distance data transmission as of February 10, 1986, may be connected thereafter up to August, 10, 1987, and may remain connected for life, without approval unless subsequently modified.

A.6 Grandfathered terminal equipment for connection to subrate and 1.544 Mbps digital services.

- a) Terminal equipment including premises wiring and protective apparatus (if any) directly connected to subrate or to 1.544 Mbps digital services on January 2, 1986, may remain connected and be reconnected to such digital services for life without approval, unless subsequently modified.
- b) New installations of terminal equipments, including premises wiring and protective apparatus (if any) may be installed including additions to existing systems) up to June 30, 1987, without approval of any terminal equipment involved, provided that these terminal equipments are of a type directly connected to subrate or 1.544 Mbps digital services as of January 2, 1986. These terminal equipments may remain connected and be reconnected to such digital services for life without approval, unless subsequently modified.

A.7 Grandfathered test equipment.

- a) Test equipment directly connected to the telephone network on February 10, 1986, is considered to be grandfathered and may remain connected to the telephone network for life without approval unless subsequently modified.
- b) New installations of test equipment may be performed up to August 10, 1987 without approval, provided that the test equipment is of a type directly connected to the public switched network or services identified in 1.1(a), (b), (c), (d), (e), and (f) for life without approval unless subsequently modified.

A.8 Grandfathered terminal equipment or systems for connection to voiceband private line channels for 2-point and multipoint private line services that utilize loop start, ringdown, or inband signaling; or voiceband metallic channels.

- a) Terminal equipment or systems, including premises wiring and protective apparatus (if any), directly connected to voiceband private lines for 2-point or multipoint service on February 10, 1986, may remain connected to that private line type service for life without approval unless subsequently modified, except for modifications allowed under A.8(c).

- b) New installations of equipments may be installed (including additions to existing systems) up to August 10, 1987 without approval of any equipments involved, provided that these equipments are of a type directly connected to voiceband private lines for 2-point or multipoint services. These equipments may remain connected to the private line-type service for life without approval, unless subsequently modified, except for modifications allowed under A.8(c).
- c) Modification to systems and installations involving unapproved equipment:
 - 1) Use of other than fully-protected premises wiring is a modification under 1.1. As an exception to the general requirements that no modification is permitted to unapproved equipment whose use is permitted under 1.1, certain modifications are authorized here-in.
 - 2) Other than fully-protected premises wiring may be used if it is qualified in accordance with procedures and requirements of § 68.215. Since there is no “responsible party” of unapproved equipment, the training and authority required by § 68.215(c) will have to be received from the equipment’s manufacturer.
 - 3) Existing separate, identifiable, and discrete protective apparatus may be removed or replaced with apparatus of lesser protective function, provided that any premises wiring to which the private line service is thereby exposed conforms to A.8(c)(2) of this section. Minor modifications to existing unapproved equipments are authorized to facilitate installation of premises wiring, so long as they are performed under the responsible supervision and control of a person who complies with § 68.215(c). Since there is no “responsible party” of unapproved equipment, the training and authority required by §68.215(c) will have to be received from the manufacturer of the equipment so modified.

A.9 Terminal equipment, including its premises wiring directly connected to PSDS (Type I, II or III)

- a) Terminal equipment, including its premises wiring directly connected to PSDS (Type I, II or III) on or before November 13, 1996, may remain for service life without approval, unless subsequently modified. Service life means the life of the equipment until retired from service. Modification means changes to the equipment that affect compliance with technical criteria in this standard or 47 CFR Part 68 rules.
- b) New installation of terminal equipment, including its premises wiring, may occur until May 13, 1998, without approval of any terminal equipment involved, provided that the terminal equipment is of a type directly connected to PSDS (Type I, II or III) as of November 13, 1996. This terminal equipment may remain connected and be reconnected to PSDS (Type I, II or III) for service life without approval unless subsequently modified.
- c) Terminal equipment including premises wiring and protective apparatus (if any) directly connected to the network on April 20, 1998, may remain connected and be reconnected for life without approval, unless subsequently modified. New installations of terminal equipment, including premises wiring

and protective apparatus (if any) may be installed (including additions to existing systems) up to May 19, 1999, without approval of any terminal equipment involved, provided that the terminal equipment is of a type directly connected to the network as of April 20, 1998. This terminal equipment may remain connected and be reconnected to the network for life without approval, unless subsequently modified.

A.10 Terminal equipment, including premises wiring directly connected to ISDN BRA or PRA

- a) Terminal equipment, including premises wiring directly connected to ISDN BRA or PRA on November 13, 1996, may remain connected to ISDN BRA or PRA for service life without approval, unless subsequently modified.
- b) New installation of terminal equipment, including premises wiring, may occur until May 13, 1998, without approval of any terminal equipment involved, provided that the terminal equipment is of a type directly connected to ISDN BRA or PRA as of November 13, 1996. This terminal equipment may remain connected and be reconnected to ISDN BRA or PRA for service life without approval unless subsequently modified.

A.11 Grandfathered central office implemented payphone equipment.

- a) Terminal equipment, including its premises wiring, that is directly connected to a central-office-implemented telephone line on or before October 8, 1997, may remain for service life without approval, unless subsequently modified. Service life means that life of the equipment until retired from service. Modification means changes to the equipment that affect the part 68-related characteristics of that equipment at the network interface.
- b) New installation of terminal equipment, including its premises wiring, may occur until April 8, 1999, without approval of any central-office-implemented telephone line equipment involved, provided that the terminal equipment is of a type directly connected to a central-office-implemented telephone line as of October 8, 1997. This terminal equipment may remain connected and be reconnected to a central-office-implemented telephone line.

Annex B (informative)

Cross-Reference to 47 CFR Part 68

This annex provides a cross-referenced index between 47 CFR Part 68 (October 2000), 47 CFR Part 68 (February 2001), and this Standard.

Table A.1 Cross-Reference to Body Text

47 CFR Part 68 (October 2000)	47 CFR Part 68 (February 2001)	TIA-968
Subpart A – General.	Subpart A - General.	
68.1 Purpose.	68.1 (no change)	1.1 Scope
68.2 Scope.	(7) 68.2 (revised) Scope.	1.2 Normative References
68.3 Definitions.	(8) 68.3 (revised) Definitions.	1.3 Definitions
68.4 Hearing aid-compatible telephones.	68.4 (no change).	
68.5 Waivers.	68.5 (no change).	
68.6 Telephones with volume control.	68.6 (no change).	
	(9) 68.7 (added) Technical criteria for terminal equipment.	
Subpart B. Conditions on Use of Terminal Equipment.	Subpart B.	2.0 Conditions on Use
68.100 General.	(10) 68.100 (revised) General.	
68.102 Registration requirements.	(11) 68.102 (revised) Terminal equipment approval requirement.	
68.104 Means of connection.	(12) Removed.	
	(13) 68.105 (added) Minimum point of entry (MPOE) and demarcation point.	
68.106 Notification to telephone company.	(14) 68.106 (revised) Notification to provider of wireline	

47 CFR Part 68 (October 2000)	47 CFR Part 68 (February 2001)	TIA-968
	telecommunications.	
68.108 Incidence of harm.	(15) 68.108 (introductory text amended) Incidence of harm.	
68.110 Compatibility of the telephone network and terminal equipment.	(16) 68.110 (revised) Compatibility of the public switched telephone network and terminal equipment.	
68.112 Hearing aid-compatibility.	68.112 (no change).	
68.160 Designation of Telecommunication Certification Bodies.	68.160 (no change).	
68.162 Requirements for Telecommunication Certification Bodies.	68.162 (no change).	
Subpart C – Registration Procedures..	(17 – change in title) Subpart C – Terminal Equipment Approval Procedures.	3.0 Procedures
68.200 Application for equipment registration.	(18) Removed.	
	(19) 68.201 (added) Connection to the public switched telephone network.	
68.202 Public notice.	(20) Removed.	
68.204 Comments and replies.	(20) Removed.	
68.206 Grant of application.	(20) Removed.	
68.208 Dismissal and return of application.	(20) Removed.	
68.210 Denial of application.	(20) Removed.	
68.211 Registration revocation procedures.	(21) 68.211 (revised) Terminal equipment approval revocation procedures.	
68.212 Assignment of equipment registration.	(22) Removed.	

47 CFR Part 68 (October 2000)	47 CFR Part 68 (February 2001)	TIA-968
68.213 Installation of other than “fully protected” non-system simple customer premises wiring.	68.213 ((23) (b) - revised) Installation of other than “fully protected” non-system simple customer premises wiring.	
68.214 Changes in registered equipment and circuitry.	(24) 68.214 (revised) Changes in other than “fully protected” premises wiring that serves fewer than four subscriber access lines.	
68.215 Installation of other than “fully protected” system premises wiring that serves more than four subscriber access lines.	(25) 68.215 (amended) Installation of other than “fully protected” system premises wiring that serves more than four subscriber access lines.	
	(25) Revised 68.215(a)(2), (a)(3), the first sentence of (d)(5), (e)(9), (g)(1) through (5), and by removing the note after (d)(2).	
68.216 Repair of registered terminal equipment and registered protective circuitry.	(26) Removed.	
68.218 Responsibility of grantee of equipment registration.	(27) 68.218 (revised) Responsibility of the party acquiring equipment authorization.	
68.220 Cross reference.	(28) Removed.	
68.224 notice of non-hearing aid compatibility.	68.224 (no change).	
68.226 Registration of digital systems components.	(29) Removed.	
Subpart D – Conditions for Registration.	(30 – heading revised) Subpart D, Conditions for Terminal Equipment Approval.	
		4.0 Tech Rqmts.
68.300 Labeling requirements.	(31) 68.300 (amended) Approval of terminal	4.1 Labeling

47 CFR Part 68 (October 2000)	47 CFR Part 68 (February 2001)	TIA-968
	equipment for connection to the public switched network.	
	(31) revised 68.300(a), removed (b), redesignated (c) as (b).	
68.302 Environmental simulation.	(32) Removed.	4.2 Environmental Sim.
68.304 Leakage current limitation.	(32) Removed.	4.3 Leakage Current Lim.
68.306 Hazardous voltage limitations.	(32) Removed.	4.4 Hazardous Voltage Lim.
68.308 Signal power limitations.	(32) Removed.	4.5 Signal Power Lim.
68.310 Transverse balance limitations.	(32) Removed.	4.6 Transverse Bal. Lim.
68.312 On-hook impedance limitations.	(32) Removed.	4.7 On-Hook Z Lim.
68.314 Billing protection.	(32) Removed.	4.8 Billing Protection
68.316 Hearing aid compatibility: Technical requirements.	68.316 (no change).	
68.317 Hearing aid compatibility volume control: technical standards.	68.317 (no change).	
68.318 Additional limitations.	68.318 (no change).	
	(33) 68.320 (added) Supplier's Declaration of Conformity.	
	(34) 68.321 (added) Location of responsible party.	
	(35) 68.322 (added) Changes in name, address, ownership or control of responsible party.	
	(36) 68.324 (added) Supplier's Declaration of Conformity requirements.	

47 CFR Part 68 (October 2000)	47 CFR Part 68 (February 2001)	TIA-968
	(37) 68.326 (added) Retention of records.	
	(38) 68.346 (added) Description of testing facilities.	
	(39) 68.348 (added) Changes in equipment and circuitry subject to a Supplier's Declaration of Conformity.	
	(40) 68.350 (added) Revocation of Supplier's Declaration of Conformity.	
	(41) 68.354 (added) Numbering and labeling requirements for terminal equipment.	
Subpart E - Complaint Procedures.	Subpart E, Complaint Procedures.	5.0 Complaints.
68.400 Content.	(No change)	
68.402 Amended complaints.	(No change)	
68.404 Number of copies.	(No change)	
68.406 Service.	(No change)	
68.408 Answers to complaints and amended complaints.	(No change)	
68.410 Replies to answers or amended answers.	(No change)	
68.412 Defective pleadings.	(No change)	
68.414 Hearing aid-compatibility: Enforcement.	(No change)	
	(42) 68.415 (added) Hearing aid-compatibility and volume control informal complaints.	
	(43) 68.417 (added) Informal complaints, form and content.	

47 CFR Part 68 (October 2000)	47 CFR Part 68 (February 2001)	TIA-968
	(44) 68.418 (added) Procedure; designation of agents for service.	
	(45) 68.419 (added) Answers to informal complaints.	
	(46) 68.420 (added) Review and disposition of informal complaints.	
	(47) 68.423 (added) Actions by the Commission on its own motion.	
Subpart F – Connectors.	(48) Removed.	6.0 Connectors.
68.500 Specifications.		6.1 Specifications.
68.502 Configurations.		6.2 Configurations.
68.504 Universal patent license agreement.		6.3 Universal patent license agreement.
68.506 Configurations used to connect multi-line communications systems such as Private Branch Exchange (PBX) and key telephone systems.		6.4 Configurations used to connect multi-line communications systems such as Private Branch Exchange (PBX) and key telephone systems.
	(49) Subpart G (added) Administrative Council for Terminal Attachments.	
	68.602 Sponsor of the Administrative Council for Terminal Attachments.	
	68.604 Requirements for submitting technical criteria.	
	68.608 Publication of technical criteria.	
	68.610 Database of terminal equipment.	
	68.612 Labels on terminal equipment.	
	68.614 Oppositions and appeals.	

Table A.2 Cross-Reference to Figures

47 CFR Part 68 (Pre-Report & Order, CC Docket 99-216)	47 CFR Part 68 (Post-Report & Order, CC Docket 99-216)	TIA-968
68.3(a)	(Removed)	1.1
68.3(b)	(Removed)	1.2
68.3(c)	(Removed)	1.3
68.3(d)	(Removed)	1.4
68.3(e)(i)	(Removed)	1.5
68.3(e)(i)	(Removed)	1.6
68.3(f)	(Removed)	1.7
68.3(g)	(Removed)	1.8
68.3(h)	(Removed)	1.9
68.3(i)	(Removed)	1.10
68.3(j)	(Removed)	1.11
68.3(k)	(Removed)	1.12
68.302(a)	(Removed)	4.1
68.302(b)	(Removed)	4.2
68.302(c)	(Removed)	4.3
68.306(a)	(Removed)	4.4
68.308(a)	(Removed)	4.5
68.308(b)	(Removed)	4.6
68.310-1(a)	(Removed)	4.7
68.310-1(b)	(Removed)	4.8
68.310(c)	(Removed)	4.9
68.310(d)	(Removed)	4.10
68.310(e)	(Removed)	4.11
68.310(f)	(Removed)	4.12
68.500(a)(1)(i)	(Removed)	6.1
68.500(a)(2)(i)	(Removed)	6.2
68.500(a)(1)(ii)	(Removed)	6.3
68.500(a)(3)(i)	(Removed)	6.4

47 CFR Part 68 (Pre-Report & Order, CC Docket 99-216)	47 CFR Part 68 (Post-Report & Order, CC Docket 99-216)	TIA-968
68.500(a)(4)(i)	(Removed)	6.5
68.500(a)(5)(i)	(Removed)	6.6
68.500(b)(2)(i)	(Removed)	6.7
68.500(b)(3)(i)	(Removed)	6.8
68.500(c)(1)(i)	(Removed)	6.9
68.500(c)(2)(i)	(Removed)	6.10
68.500(c)(2)(ii)	(Removed)	6.11
68.500(c)(3)(i)	(Removed)	6.12
68.500(c)(4)(i)	(Removed)	6.13
68.500(c)(5)(i)	(Removed)	6.14
68.500(d)(3)	(Removed)	6.15
68.500(d)(2)(i)	(Removed)	6.16
68.500(d)(3)(i)	(Removed)	6.17
68.500(e)(1)	(Removed)	6.18
68.500(e)(2)	(Removed)	6.19
68.500(e)(3)	(Removed)	6.20
68.500(e)(4)	(Removed)	6.21
68.500(f)(1)	(Removed)	6.22
68.500(f)(2)	(Removed)	6.23
68.500(f)(3)	(Removed)	6.24
68.500(g)(1)	(Removed)	6.25
68.500(g)(2)	(Removed)	6.26
68.500(h)	(Removed)	6.27
68.500(i)(1)(i)	(Removed)	6.28
68.500(i)(2)(i)	(Removed)	6.29
68.500(i)(2)(ii)	(Removed)	6.30
68.500(i)(3)(i)	(Removed)	6.31
68.500(i)(4)(i)	(Removed)	6.32
68.500(i)(5)(i)	(Removed)	6.33
68.500(j)(1)	(Removed)	6.34

47 CFR Part 68 (Pre-Report & Order, CC Docket 99-216)	47 CFR Part 68 (Post-Report & Order, CC Docket 99-216)	TIA-968
68.500(j)(2)(i)	(Removed)	6.35

Table A.3 Cross-Reference to Tables

47 CFR Part 68 (Pre-Report & Order, CC Docket 99-216)	47 CFR Part 68 (Post-Report & Order, CC Docket 99-216)	TIA-968
68.304(a)	(Removed)	4.1
68.306(a)	(Removed)	4.2
68.306(b)	(Removed)	4.3
68.306(c)	(Removed)	4.4
68.308(a)	(Removed)	4.5
68.308(b)	(Removed)	4.6
68.308(c)	(Removed)	4.7
68.308(d)	(Removed)	4.8
68.308(e)	(Removed)	4.9
68.310(a)	(Removed)	4.10
68.310(b)	(Removed)	4.11
68.312(a)	(Removed)	4.12
68.312(b)	(Removed)	4.13

This page left intentionally blank.

Annex C (informative)

Informative Definitions

The following definitions are found in the 47 CFR Part 68, Subpart A, and are provided below as reference:

- C.1. **Demarcation point (also point of interconnection):** As used in this part, the point of demarcation and/or interconnection between the communications facilities of a provider of wireline telecommunications, and terminal equipment, protective apparatus or wiring at a subscriber's premises.
- C.2. **Essential telephones:** Only coin-operated telephones, telephones provided for emergency use, and other telephones frequently needed for use by persons using such hearing aids.
- C.3. **Harm:** Electrical hazards to the personnel of providers of wireline telecommunications, damage to the equipment of providers of wireline telecommunications, malfunction of the billing equipment of providers of wireline telecommunications, and degradation of service to persons other than the user of the subject terminal equipment, his calling or called party.
- C.4. **Hearing aid compatible:** Except as used at 47 CFR Part 68.4(a)(3) and 68.414, the terms hearing aid compatible or hearing aid compatibility are used as defined in 68.316, unless it is specifically stated that hearing aid compatibility volume control, as defined in 68.317, is intended or is included in the definition.
- C.5. **Inside wiring or premises wiring:** Customer-owned or controlled wire on the subscriber's side of the demarcation point.
- C.6. **Premises:** As used herein, generally a dwelling unit, other building or a legal unit of real property such as a lot on which a dwelling unit is located, as determined by the provider of telecommunications service's reasonable and nondiscriminatory standard operating practices.
 - C.6.1 **Non-system premises wiring:** Wiring that is used with up to four-line business and residence services, located at the subscriber's premises.
 - C.6.2 **Fully protected non-system premises wiring:** Non-system premises wiring which is electrically behind approved (or grandfathered) equipment or protective circuitry that assures that electrical contact between the wiring and commercial power wiring or earth ground will not result in hazardous voltages at the telephone network interface.
 - C.6.3 **Unprotected non-system premises wiring:** All other non-system premises wiring.
- C.7. **Private radio services:** Private land mobile radio services and other communications services characterized by the Commission in its rules as private

radio services.

- C.8. **Responsible party:** The party or parties responsible for the compliance of terminal equipment or protective circuitry intended for connection directly to the public switched telephone network with the applicable rules and regulations in this part and with the technical criteria published by the Administrative Council for Terminal Attachments. If a Telecommunications Certification Body certifies the terminal equipment, the responsible party is the holder of the certificate for that equipment. If the terminal equipment is the subject of a Supplier's Declaration of Conformity, the responsible party shall be: the manufacturer of the terminal equipment, or the manufacturer of protective circuitry that is marketed for use with terminal equipment that is not to be connected directly to the network, or if the equipment is imported, the importer, or if the terminal equipment is assembled from individual component parts, the assembler. If the equipment is modified by any party not working under the authority of the responsible party, the party performing the modifications, if located within the U.S., or the importer, if the equipment is imported subsequent to the modifications, becomes the new responsible party. Retailers or original equipment manufacturers may enter into an agreement with the assembler or importer to assume the responsibilities to ensure compliance of the terminal equipment and to become the responsible party.
- C.9. **Secure telephones:** Telephones that are approved by the United States Government for the transmission of classified or sensitive voice communications.
- C.10. **Terminal equipment:** As used in this part, communications equipment located on customer premises at the end of a communications link, used to permit the stations involved to provide telecommunications or information services.

Annex D (informative)

Informative Definitions

The following definitions previously were in 47 CFR 68.3.

- D.1. The following definitions were subdefinitions of “Demarcation Point” (see Annex C).
- D.1.1. **Single-unit installations:** For single unit installations existing as of August 13, 1990, and installations installed after that date the demarcation point shall be a point within 30 cm (12 in) of the protector or, where there is no protector, within 30 cm (12 in) of where the telephone wire enters the customer’s premises, or as close thereto as practicable.
- D.1.2. **Multiunit installations:**
- a) In multiunit premises existing as of August 13, 1990, the demarcation point shall be determined in accordance with the local carrier’s reasonable and non-discriminatory standard operating practices. Provided, however, that where there are multiple demarcation points within the multiunit premises, a demarcation point for a customer shall not be further inside the customer’s premises than a point twelve in from where the wiring enters the customer’s premises, or as close thereto as practicable.
 - b) In multiunit premises in which wiring is installed after August 13, 1990, including major additions or rearrangements of wiring existing prior to that date, the telephone company may establish a reasonable and nondiscriminatory practice of placing the demarcation point at the minimum point of entry. If the telephone company does not elect to establish a practice of placing the demarcation point at the minimum point of entry, the multiunit premises owner shall determine the location of the demarcation point or points. The multiunit premises owner shall determine whether there shall be a single demarcation point location for all customers or separate such locations for each customer. Provided, however, that where there are multiple demarcation points within the multiunit premises, a demarcation point for a customer shall not be further inside the customer’s premises than a point 30 cm (12 in) from where the wiring enters the customer’s premises, or as close thereto as practicable.
 - c) In multiunit premises with more than one customer, the premises owner may adopt a policy restricting a customer’s access to wiring on the premises to only that wiring located in the customer’s individual unit that serves only that particular customer.
- D.2. The following definitions were subdefinitions of Inside (premises) wiring.
- D.2.1. **System premises wiring:** Wiring which connects separately housed equipment entities or system components to one another, or wiring which connects an equipment entity or system component with the telephone network interface, located at the customer’s premises and not within an equipment housing.
- D.2.2. **Fully protected systems premises wiring:** Premises wiring that is either: No greater than 15 m (50 feet) in length (measured linearly between the points where it

leaves equipment or connector housings) and approved as a component of and supplied to the user with the approved terminal equipment or protective circuitry with which it is to be used. Such wiring shall either be pre-connected to the equipment or circuitry, or may be so connected by the user (or others) if it is demonstrated in the approval application that such connection by the untrained will not result in harm, using relatively fail-safe means. A cord that complies with the previous section either as an integral length or in combination with no more than one connectorized extension cord. If used, the extension cord shall comply with the requirements of 47 CFR Part 68.200(h). Wiring located in an equipment room with restricted access, provided that this wiring remains exposed for inspection and is not concealed or embedded in the building's structure, and that it conforms to 47 CFR Part 68.215(d). Electrically behind approved (or grandfathered) equipment, system components or protective circuitry which assure that electrical contact between the wiring and commercial power wiring or earth ground will not result in hazardous voltages or excessive longitudinal imbalance at the telephone network interface.

D.2.3. **Protected system premises wiring requiring acceptance testing for imbalance:** Premises wiring which is electrically behind approved (or grandfathered) equipment, system components or circuitry which assure that electrical contact between the wiring and commercial power wiring will not result in hazardous voltages at the telephone network interface.

D.2.4 **Unprotected system premises wiring:** All other premises wiring.

Annex E (informative)

Informative References

- E.1. Part 68 Application Guide: A document produced by TIA TR41.11 Subcommittee on Administrative Regulatory Considerations to provide administrative guidance on Part 68 implementation.
(See also: www.tiaonline.org/standards/sfg/tr-41)
- E.2. Industry Canada, Standard CS-03, *Standard for Terminal Equipment, Systems, Network Protection Devices and Connection Arrangements*.
- E.3. ANSI T1.413-1998, *Network and Customer Installation Interfaces – Asymmetric Digital Subscriber Line (ADSL) Metallic Interface*
- E.4. ANSI T1.417-2001, *Spectrum Management for Loop Transmission Systems*

For additional information about references, contact the respective organizations at the following addresses:

ANSI	American National Standards Institute 1819 L Street, NW Washington, DC 20036 (212) 642-4900 www.ansi.org
FCC	Federal Communications Commission 445 12th St. SW Washington DC 20554 (202) 418-0190 www.fcc.gov
ITU	International Telecommunication Union Place des Nations CH-1211 Geneva 20 Switzerland +41 22 730 51 11 www.itu.int
TIA	Telecommunications Industry Association 2500 Wilson Blvd., Suite 300 Arlington, VA 22201 USA (703) 907-7700 www.tiaonline.org

REMOVE THE FOLLOWING BEFORE PUBLICATION

TR41.9.1 Writing Committee – Work Program & Revision Log

(This section is only for the writing groups convenience will be deleted from the final draft.)

Phil Havens, P.E. Chair
 John Shinn, P.E. Co-Editor
 Anh Nguyen, Co-Editor

Draft Rev	Date	Description of Change	Authorization
1.0			
2.0			
3.0			
4.0	1 May 2002	Contribution -005R2 adds transverse balance requirements- Tim L Cisco Contribution -017R1 ADSL req'mnts - Peter W Paradyne Contribution -020 Encoded Analog Content - Trone B Verizon Contribution -022 Frequency domain template - Larry Bell - Adtran Contribution -060R1 (from Nov 01) Stutter dial tone - Steve W Vtech Concept to add Annex to show revision history (see draft 129 for example)	Vancouver Feb 2002
		Contribution -006 correct table in 4.5.5.2.1 - Tim L Cisco	Crystal City May 2002

