

Common Regulations for Competitors: Safety

Page

156	Roll-Over Protection Systems
162	Seats, Seat Belts and Headrests
164	Fire Extinguishers
166	Safety Fuel Cells
166	Red Warning Light
166	Tank Fillers, Vents and Caps
166	Crushable Structure
168	External Circuit Breaker
168	Overalls
168	Crash Helmets
172	Goggles or Visors
172	Front Engined Cars
174	Head Restraints
174	General Safety Recommendations
176	Appendix 1: Tables and Drawings
179	Appendix 2: Safety Cage Drawings

Reference should be made to the appropriate sections in the specific regulations as to which of the following are mandatory or recommended for any particular branch of motor sport.

Roll-Over Protection Systems

Introduction

1. The following are various specifications and configurations that can be used in manufacturing, preparing and installing Roll-Over Protection Systems (ROPS) into Production Cars, Touring Cars Saloon and Sports Cars (1.6.1), Sports Racing Cars (1.6.2), Single Seaters (1.6.3), and other forms of Competition Vehicles (1.6.4). The details covered in this section give many permutations, the MSA mandatory requirements

Note: Throughout these sections an asterisk (*) indicates a requirement for additional information to be printed in the Supplementary Regulations (SRs).

Text shown in Italics indicate a Regulation which may be amended in the SRs.

are the minimum acceptable. Care should be taken to check FIA International requirements for Groups, Classes and Formulae which may not be covered by this section, which is for MSA National 'A' and lower status events.

Definitions

1.1.1. Safety Cage. A structural framework designed to prevent serious bodyshell deformation in the case of a collision or a car turning over.

1.1.2. Rollbar. Structural frame or hoop and mounting points.

1.1.3. Rollcage. Structural framework made up of a main rollbar and a front rollbar (or two lateral rollbars), their connecting members, one diagonal member, backstays and mounting points (see drawings K5 and K6).

1.1.4. Main Rollbar. Structure consisting of a near-vertical frame or hoop located across the vehicle just behind the front seats.

1.1.5. Front Rollbar. Similar to main rollbar but its shape follows the windscreen pillars and top screen edge.

1.1.6. Lateral Rollbar. Structure consisting of a near-vertical frame or hoop located along the right or left hand side of the vehicle. The rear legs of a lateral rollbar must be just behind the front seats. The front leg must be against the screen pillar and dashboard such that it does not unduly impede entry or exit of driver or co-driver.

1.1.7. Longitudinal Member. Longitudinal tube which is not a part of the main, front or lateral rollbar, for example, a backstay.

1.1.8. Diagonal Member. Transverse tube between a top corner of the main rollbar or upper end of a backstay and a lower mounting point on the opposite side of the rollbar or backstay.

1.1.9. Framework Reinforcement. Reinforcing member fixed to the rollcage to improve its structural efficiency.

1.1.10. Reinforcement Plate. Metal plate fixed to the bodyshell or chassis structure under a rollbar mounting foot to spread load into the structure.

1.1.11. Mounting Foot. Plate welded to a rollbar tube to permit its bolting or welding to the bodyshell or chassis structure, usually onto a reinforcement plate.

1.1.12. Removable Members. Structural members of a safety cage which are able to be removed.

1.1.13. Harness Bar. A transverse tubular member attached across either the main hoop or backstays to accept harness mountings.

Specifications

1.2.1. ROPS must be designed and made so that, when correctly installed, they substantially reduce the risk of injury to the occupants. The essential features of an efficient ROPS are that it is designed to suit the particular vehicle, is of sound construction, has

Safety Devices



Roll Cages

- Over 40 years' experience
- Widest range of roll cages
- Fitting available at Safety Devices HQ
- Full body shell preparation available
- Bespoke roll cages designed and manufactured
- Padding and Harnesses

Safety Devices International Ltd

Cambridge House, Holborn Avenue, Mildenhall, Suffolk IP28 7AN

Tel: +44 (0) 1638 713 606

motorsport@safetydevices.com

www.safetydevices.com

adequate mountings and is a close fit to the bodyshell.

1.2.2. The ROPS must not unduly impede Driver and Co-Driver access to the vehicle. Members may intrude into the interior space by passing through the dashboard, front side trim, rear side trim, and rear seats which may be folded down. ROPS must not extend beyond the front upper or rear suspension mounting points of the vehicle, with the exception of backstays which may extend beyond the rear suspension mounting points if necessary to achieve the required 30° angle. Any modification to a homologated ROPS (other than fitment of door bars and harness bars) is prohibited. Tubes must not carry any fluids.

1.2.3. Compulsory Diagonal Member. Different ways of fitting the compulsory diagonal member (see drawings K5 and K6). The combination of several members is permitted.

1.2.4. Optional Reinforcing Members. Each type of reinforcement (see drawings K7 to K12) may be used separately or combined with others.

1.2.5. Deleted.

Technical Specifications

1.3.1. Main, Front and Lateral Rollbars. These frames or hoops must be made in one piece without joints. Their construction must be smooth and even, without ripples or cracks. The vertical part of the main rollbar must be as straight as possible and as close as possible to the interior contour of the bodyshell. The front leg of the front rollbar or a lateral rollbar must be straight, or if it is not possible, must follow the windscreen pillars and have only one end unless a windscreen pillar reinforcement [1.3.5(e)] is fitted.

The mounting foot must not be rearward of the foremost point of the rollbar.

Where the main rollbar forms the rear legs of a lateral rollbar (see drawing K6), the connection to the lateral rollbar must be at roof level. To achieve an efficient mounting to the bodyshell, the original interior trim may be modified around the safety cage and its mountings by cutting it away or by distortion. However, this modification does not permit the removal of the complete parts of upholstery or trim. Where necessary, the fusebox may be relocated to enable a rollcage to be fitted.

1.3.2. Mounting of ROPS to the Bodyshell.

Minimum mountings are:

- 1 for each leg of the main or lateral rollbar.
- 1 for each leg of the front rollbar.
- 1 for each backstay (see 1.3.3).

Each mounting foot of the front, main and lateral rollbars must include a reinforcement plate of a material of at least the same thickness as the wall of the tube to which it is being welded (minimum 3mm).

Each mounting foot must be attached by at least three bolts, minimum M8 150 grade 8.8, on a steel reinforcement plate at least 3mm thick and of at least 120cm² area which is welded to the bodyshell (see drawings K13 to K18). The mounting feet may alternatively be welded direct to the reinforcement plate. This does not apply to backstays (see 1.3.3).

1.3.3. Backstays. These are compulsory and must be attached near the roofline and near the top outer bends

of the main rollbar on both sides of the car. They must make an angle of at least 30° with the vertical, must run rearwards and be straight and as close as possible to the interior side panels of the bodyshell. Their materials specification, diameter and thickness must be as defined in 1.4.1. Forward facing stays are permitted if an angle of 30° cannot be achieved with Backstays, providing they do not unduly impede Driver and Co-Driver access to the vehicle.

Their mountings must be reinforced by plates. Each backstay should be secured by bolts having a cumulative section area at least two thirds of that recommended for each rollbar leg mounting in 1.3.2 above, and with identical reinforcement plates of a least 60cm² area (see drawing K19).

A single bolt in double shear is permitted, providing it is of adequate section and strength (see drawing K20) and provided that a bush is welded into the backstay.

The mounting feet may alternatively be welded direct to the reinforcement plate.

1.3.4. Diagonal Members. At least one diagonal member must be fitted. Their location must be in accordance with drawings K5 or K6 and they must be straight. The combination of several diagonal members is permitted.

Where two diagonals in the form of a cross are used, at least one of the diagonals must be a single piece tube.

The attachment points of the diagonal members must be so located that they cannot cause injuries. They may be made removable but must be in place during events. The lower end of the diagonal must join the main rollbar or back-stay not further than 100mm from the mounting foot. The upper end must join the main rollbar not further than 100mm from the junction of the backstay joint, or the backstay not more than 100mm from its junction with the main rollbar.

They must comply with the minimum specification set out in 1.4.1. A diagonal member fixed to the bodyshell must have reinforcement plates as defined in 1.3.3.

1.3.5. Optional Reinforcement of ROPS. The diameter, thickness and material of reinforcements must be as defined in 1.4.1. They must be either welded in position or installed by means of demountable joints.

Reinforcement tubes must not be attached to the bodyshell.

(a) Transverse Reinforcing Members:

The fitting of two transverse members as shown in drawing K9 is permitted. The transverse member fixed to the front rollbar must not encroach upon the space reserved for the driver or co-driver. It must be placed as high as possible but its lower edge must not be higher than the top of the dashboard.

(b) Doorbars (for side protection):

Longitudinal members must be fitted at each side of the vehicle (see drawings K9 and K12). They may be removable.

The side protection must be as high as possible but not higher than one half of the total height of the door aperture measured from its base.

Where two members in the form of a cross are used, at least one of the members must be a single piece tube.

Where configuration 12(j) is used a reinforcing gusset must connect the tubes along the horizontal length.

The one stop shop for automotive engineering and fabrication

Tubular and sheet metal fabrications

Folded and bonded sheet metal structures

Laser cutting; sheet and tubular components

CNC tube and sheet metal bending

CNC Machining

Powder coating

3D CAD specialists utilising Solidworks and Catia v6



(K) Competitors: Safety

(c) Roof Reinforcement:

Reinforcing the upper part of the rollcage by adding members as shown in drawing K10 is permitted.

(d) Reinforcement of bends and junctions:

The reinforcement of the junction between the main rollbar or the front rollbar and the longitudinal members is permitted as shown in drawing K12 as is the reinforcement of the top rear bends of the lateral rollbars.

The ends of these reinforcing tubes must not be more than half way down or along the members to which they are attached.

(e) Windscreen Pillar Reinforcement:

A tube the upper end of which must be less than 100mm from the junction between the front (lateral) rollbar and the longitudinal (transversal) member and the lower end less than 100mm from the front mounting foot of the front (lateral) rollbar, as shown in drawing K62.

The tube may be bent on condition that it is straight in side view and that the angle of the bend does not exceed 20°.

1.3.6. Protective Padding. Where the driver's or co-driver's bodies or crash helmets could come into contact with the ROPS, non-flammable padding should be provided for protection (1.6.6).

1.3.7. Removable Members. Should removable members be used in the construction of a ROPS, the demountable joints used must comply with an approved type (see drawings K21 to K30). The screws and bolts must be of adequate diameter and of ISO Standard 8.8 or better. FIA homologated demountable joints are also permitted.

Demountable joints must not be used as part of a main, front or lateral rollbar because they act as hinges in the principal structure and allow deformation. Their use is solely for attaching members to the rollbars and for attaching a lateral rollbar to a main rollbar (see drawing K2). In this last case, hinged joints in drawings K21 to K30 must not be used.

1.3.8. Guidance on Welding. All welding should be of the highest possible quality with full penetration and preferably using a gas shielded arc. Although good external appearance of a weld does not necessarily guarantee its quality, poor looking welds are never a sign of good workmanship. When using heat-treated steel the instructions of the manufacturer must be followed (special electrodes, gas protected welding). It is to be emphasised that the use of heat-treated or medium carbon steels may cause problems and that bad fabrication may result in a decrease in strength (caused by brittle heat-affected zones) or inadequate ductility.

1.3.9. Harness Bars. Minimum dimensions 38mm x 2.5mm or 40mm x 2.0mm. Cold Drawn Seamless Carbon Steel with minimum tensile strength of 350N/mm². Harness straps may be attached by looping around the tube or by threaded fixings using inserts as drawing No. 44 welded into the tubes(s).

Material Specifications

1.4.1. Specifications of the tubes used:

Minimum Material

Cold Drawn Seamless Unalloyed Carbon Steel, containing a maximum of 0.3% of carbon.

Note: For an unalloyed carbon steel the maximum content of additives is 1.7% for manganese and 0.6% for other elements.

Minimum Yield Strength

350 N/mm²

Minimum Dimensions (Ø in mm)

a) Mandatory tubular members

45 x 2.5 (1.75" x 0.095") or 50 x 2.0 (2.0" x 0.083").
38 x 2.5 (1.5" x 0.095") or 40 x 2.0 (1.6" x 0.083").
(For roll cages/bars approved prior to 1.1.95).

b) Optional tubular members

38 x 2.5 (1.5" x 0.095") or 40 x 2.0 (1.6" x 0.083").

1.4.2. In selecting the steel, attention must be paid to obtaining good elongation properties and adequate weldability.

1.4.3. The tubing must be bent by a cold working process and the centreline bend radius must be at least three times the tube diameter. If the tubing is ovalised during bending, the ratio of minor to major diameter must be 0.9 or greater.

Exceptions

The only exceptions to the foregoing requirements for Saloon, single seater and Sports Cars are as follows:

1.5.1. ROPS manufacturers may make application to the MSA for a Roll Over Protection System (ROPS) Certificate to be issued.

Note: ROPS manufacturers wishing to make application for such a certificate should contact the MSA Technical Department in order to obtain details of the requirements to be met and the fees payable. Subject to these requirements being met a ROPS Certificate will be raised and issued. Duly authorised copies of this certificate containing a drawing, photographs, a copy of the manufacturers declaration that the ROPS meets the required regulations should be available to event Scrutineers.

1.5.2. Each ROPS manufactured after 1.1.97 for which the MSA or the FIA has issued a ROPS (Rollcage) Certificate must bear an identification plate which details the manufacturer and the manufacturer's part number allocated to the cage. Details of this identity plate are to be included on the ROPS (Rollcage) certificate.

Vehicle Categories Covered

1.6.1. Series Production, Touring and Sports Cars.

- Production cars, Touring Cars, Sports cars up to 2,000cc – Basic rollbar/rollcage complying with K1 or K2.
- Production Cars and Touring Cars over 2,000cc – Rollbar/rollcage complying with K3 or K4.
- Sports cars over 2,000cc – Rollbar/rollcage complying with K3 or K4 or K60(i) & (ii) and K31.

The different possibilities of installing the optional reinforcing members to the rollcage are shown in drawings K7 to K12.

Each type of reinforcement (drawings to K7 to K12) may be used separately or combined with one or several others).

These reinforcements can be installed in each of the basic rollcages (drawings K1 to K4).



www.ppcages.com

Roll Cages + Tube Manipulation



From simple bent hoops to mass produced Roll Cages ready to fit for Prototypes, Modern & Historic Cars and Trucks. Built to MSA and FIA Specification.

CNC Tube manipulation and bending including 3D curving from 19mm - 130mm OD.

One of the largest Stockholders of Roll Cage tubing in the UK.

ONE LIFE. PROTECT IT.

Kelbrook Business Park, Kelbrook, Lancashire, BB18 6SW

Tel: +44(0) 1282 842200 Fax: +44(0) 1282 843300 Email: sales@ppcages.com



CUSTOM CAGES

UK'S LEADING ROLL CAGE MANUFACTURER



- Manufacturers of Roll Cages for GT3, WRC and R1 -> R5
- Development from CAD files or reverse engineering
- In-house CAD design and CNC manufacturing
- Roll Cages for Historic Race & Rally
- NGTC design & development service
- Bespoke, confidential design service

sales@customcages.co.uk

T: 01327 872855 F: 01327 300758

Baird Close, Daventry, Northants, NN11 8RY

www.customcages.co.uk

(K) Competitors: Safety

Minimum material

As defined in 1.4.

Note: For all the ROPS which are FIA homologated after 1.1.2000 for Touring cars, the presence of the ROPS in the door aperture must comply with the following criteria (see drawing No. 43 in this section).

Dimension A must be a minimum of 300mm.

Dimension B must be a maximum of 250mm.

Dimension C must be a maximum of 300mm.

Dimension D (Measured from the upper corner of the windscreen, without the seal) must be a maximum of 100mm.

Dimension E must not be more than half height of the door aperture.

MSA Certified and non-homologated ROPS constructed after 1.1.2001 in accordance with drawing 12 must also comply with the above dimensions.

Vehicles of Periods A-Z as defined within the current FIA yearbook for which a valid FIA Historic Technical Passport (HTP) has been issued – be fitted with a rollbar/rollcage as specified within the HTP issued for each individual vehicle and with that vehicle being in compliance with that specification.

1.6.2. Sports Racing Cars

The rollbar must conform to drawings K60(i) and K31. Forward facing stays are permitted for open Sports Racing Cars.

Minimum height 92cm measured along the line of the driver's spine from the bottom of the car seat.

Minimum material

Cold drawn seamless Carbon Steel 350N/mm²

Minimum dimensions

48.3 dia. x 2.6mm (1.87in x 0.104in).

1.6.3. Single Seater Racing Cars

The rollbar must be symmetrical about the lengthwise centre-line of the car and of minimum height 90cm measured vertically from the base of the cockpit or 92cm measured along the line of the driver's spine from the bottom of the car seat. There must be at least one brace rearwards from the top of the rollbar at an angle not exceeding 60° with the horizontal, this brace must be the same diameter as the rollbar, if two braces are fitted to the tube the diameter may be reduced to 26mm the wall thickness being maintained. Where two braces are fitted, they may be rearward or forward facing.

The width inside the roll-over bar main tubes must be 38cm minimum measured 60cm above the base of the seat. It must incorporate a crossbrace to restrain the driver's head and give rearward support. The top hoop radius must not be less than 10cm measured at the centre line of the tube.

Minimum material

Cold drawn seamless Carbon steel 350N/mm²

Minimum dimensions

42.4 dia. x 2.6mm (1.62in x 0.104in).

1.6.4. Other Considerations

- (a) An effective rollbar must be fitted with its top edge not less than 5cm above the helmet of the normally seated driver. It must be wider than the driver's shoulders at that height. It must be constructed of good quality seamless steel tubing of minimum 35mm diameter and wall thickness of

2mm. It should have the top bar straight or slightly curved but no tubes meeting in an inverted 'V'. It must be effectively braced to structural members.

- (b) Non-standard cars are advised to fit a rollbar to the following minimum requirements. Minimum height 72cm from the rear of the uncompressed seat cushion. It must have minimum flat width of 38cm running into radiused corners and affording driver and passenger equal protection.

It must be effectively mounted and braced to structural members forward and aft of the cockpit and not less than cockpit width. It must be constructed of good quality seamless steel tubing of minimum 32mm diameter and wall thickness of 1.5mm.

1.6.5. ALL aluminium alloy Roll Cages are prohibited.

1.6.6. It is recommended that rollbar/rollcage tubes within 150mm of a vehicle occupant's helmet are covered with a suitable energy absorbing material. A number of suitable materials are homologated by the FIA who publish specific regulations for the fitment of such materials for vehicles participating in International Events.

Aerodynamics

1.7. The use of a rollbar to achieve or supplement aerodynamic effects is prohibited.

Future

1.8. It is to be noted that the FIA publishes Regulations concerning ROPS for use in International competition. The MSA aligns itself with these regulations wherever possible.

Seats, Seat Belts and Headrests

2.1. All seat safety belts must be complete units sourced from a recognised manufacturer and fitted in accordance with the manufacturers' instructions, MSA recommendations or FIA requirements. (See Drawing Nos. 39, 40, 41, 42 and 44.)

Where the vehicle manufacturer's standard safety belts and associated fitments are not utilised, bolts must be of a minimum 7/16in UNF or M12 (grade 8.8).

2.1.1. **Three point.** One diagonal shoulder strap and one lap strap, with three anchorage points on the chassis/body shell or roll over bar of the vehicle on either side and to the rear of the driver's seat.

2.1.2. **Four point.** Two shoulder straps and one lap strap, with four anchorage points on the chassis/body shell or roll over bar of the vehicle, one either side of the driver and two to the rear of the driver's seat.

2.1.3. **Five point.** Two shoulder straps, one lap strap and one strap between the legs with five anchorage points on the chassis/body shell or roll over bar of the vehicle, one either side of the driver, two to the rear of the driver's seat and one between the legs.

2.1.4. **Six Point.** Two shoulder straps, one lap strap and two straps between the legs, with six anchorage points on the chassis/body shell or roll over bar of the vehicle, one either side of the driver, two to the rear of the driver's seat and two between the legs.

2.1.5. Where safety harnesses are mandatory it is recommended that those described in 2.1.2, 2.1.3 and 2.1.4 are homologated by the FIA and carry their label.



Predator
FIA 8862-2009



Revenge
FIA 8855-1999



Revolution
FIA 8855-1999



Pro-Series
FIA 8855-1999



Sprint
FIA 8855-1999

Trust the brand

For over 50 years Corbeau have been at the forefront of driver safety.

Priding ourselves on supplying quality products, excellent advice and unequalled aftercare.

We are stockists of a full range of FIA seats, harnesses and HANS devices.



Pro seat moulded inserts

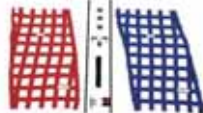

If you are serious about motorsport ensure you have the best available equipment.

All competition licence holders call now for your 2017 preferential package.

For all your needs call Nick, Dan or Steve to discuss your requirements

17 Wainwright Close, St Leonards on Sea, East Sussex. TN38 9PP

Tel: +44(0)1424 854499 Fax: +44(0)1424 854488

Make sure your equipment is in date

(K) Competitors: Safety

2.1.6. It is permitted to make a hole in series production seats to allow secure anchoring of seat belts.

2.1.7. All seat belts used on International events must be homologated by the FIA, and carry their label.

2.1.8. It is not permitted to mix parts of seat belts. Only complete sets as supplied by manufacturers are to be used.

2.1.9. Only one release mechanism is permitted on each seat belt configuration and this must be available for the wearer to operate whilst seated in the competing position.

2.1.10. The anchorage points to the rear should be positioned so that the strap from the shoulder is as near horizontal as possible. It should not be located on the floor directly behind the driver/co-driver.

2.1.11. Seat belts once involved in a serious accident should be discarded as they are likely to have stretched. Belts subjected to oil, acid or heat should be replaced.

2.2. Seats. All seats should be correctly located and securely anchored in such a way as to allow no movement in squab or backrest. When installing a Competition Seat, carry out the following checks before selection or purchase:

- (a) Study the requirements of the vehicle concerned and ask the manufacturer's advice and recommendations.
- (b) Check that the seat is suitable for the type of forces to which it could be subjected. These will include fore and aft and lateral loadings.
- (c) Check that the seat carries full instructions for installation in your vehicle.
- (d) Check that suitable mounting installations are available from the manufacturer.
- (e) Ask the manufacturer to confirm that the seat frame is suitable for your Motor Sport discipline.
- (f) If the original seat attachments or supports are changed, the new parts must either be approved for that application by the seat manufacturer or must comply with the following specifications (see drawing No. K32).

2.2.1. Supports must be attached to the shell/chassis via at least 4 mounting points per seat using bolts with a minimum diameter of 8mm and counterplates, according to drawing No. K32. The minimum area of contact between support, shell/chassis and counterplate is 40 sq cm for each mounting point. In Series Production Cars manufacturers' standard seat mounting points may be used. If quick release systems are used, they must be capable of withstanding vertical and horizontal forces of 18000N, applied non-simultaneously. If rails for adjusting the seat are used, they must be those originally supplied with the homologated car or with the seat.

2.2.2. The seat must be attached to the supports via 4 mounting points, 2 at the front and 2 at the rear of the seat, using bolts with a minimum diameter of 8mm and reinforcements integrated into the seat.

Each mounting point must be capable of withstanding a force of 15000N applied in any direction.

2.2.3. The minimum thickness of the supports and counterplates is 3mm for steel and 5mm for light alloy

materials. The minimum longitudinal dimension of each support is 6cm.

2.3. Headrests. On all vehicles where it is not mandatory (13) it is strongly recommended that a head restraint in the form of a headrest be fitted, as near to the driver's/co-driver's helmet as possible, to prevent whiplash of the neck and spine in case of impact. It is recommended that they comply with 13.

Fire Extinguishers

3. A fire extinguisher/extinguishing system must be carried on all vehicles, the minimum requirement being that the system be charged with one of the permitted extinguishants and be operable by the driver whilst normally seated either by manual operation or by a mechanically/electrically assisted triggering system.

It is recommended that all extinguishers are serviced in accordance with the manufacturers guidelines, or every 24 months, whichever is sooner.

3.1. Capacities. Extinguishers are classified as Small, Medium or Large, and designated as Hand-Held or Plumbed-In. Dry powder extinguishers are prohibited.

3.1.1. Small, Hand operated.

3.1.2.

(a) Medium, Plumbed-In, for discharge into both cockpit and engine compartment.

(b) Medium, Hand-Operated, for discharge into both cockpit and engine compartment.

3.1.3. Large, Plumbed-In, for discharge into both cockpit and engine compartment.

3.1.4. Large, Plumbed-In, for discharge into Engine compartment, plus Medium, Hand-Held for Driver or Rally Co-driver use.

3.1.5. Hand-operated for cockpit (International).

3.1.6. Permitted Extinguishants AFFF, ZERO 2000. (See Table 3.)

Copies of the list of FIA/MSA approved plumbed systems are available from the MSA.

3.2. Plumbed-In Systems (If AFFF they must be FIA/MSA homologated).

3.2.1. The Large unit should have two points of triggering, one for the driver (and Co-driver in Rallies) and one outside the car for activation by Marshals etc.

3.2.2. The triggering point from the exterior must be positioned close to the Circuit Breaker (or combined with it) and must be marked by the letter "E" in red inside a white circle of at least 10cm diameter with a red edge.

3.2.3. In installing units, the direction of nozzles should be carefully considered, Induction, Exhaust, Ignition and Fuel pumping systems being the most likely areas for fire to occur.

3.2.4. Where possible sources of fire exist outside the engine or cockpit areas (i.e. front mounted fuel tanks) advice can be sought from the MSA concerning plumbed-in system installations.

3.2.5. All bottles should discharge simultaneously and must be operable in any position of the car even if inverted.

Forward thinking

For anyone looking to upgrade their fire suppression system, Lifeline's popular **Fire Marshal** brand has now been extended to the Zero 360 range offering all the efficient, lightweight and compact benefits of the **Zero 360 Novec™ 1230** series.

zero®
360



- FIA Homologated
- Smaller and lighter than ever
- 2.25kg Novec™ 1230 liquid clean agent extinguishant
- Constant discharge in any orientation
- Excellent fire knock down and fire out capabilities
- Two year service cycle
- The choice of world championship winning constructors

Safety products

RACE
MIRRORS



RAIN LIGHTS



QUICK RELEASE
STEERING
BOSSSES



ROLLCAGE
PADDING



Onboard Fire Safety Systems

zero®
360

zero®
2000

zero®
0



ALL LIFELINE PRODUCTS
DESIGNED AND MADE IN
THE UK



lifeline

Fire & Safety Systems Ltd.

Champions of Safety

www.lifeline-fire.co.uk

UK Phone: +44 (0)24 7671 2999 | USA Phone: +1 (540) 251 2724 | Email: sales@lifeline-fire.co.uk

(K) Competitors: Safety

3.2.6. The fitting of a pressure gauge is recommended (mandatory for pressurised AFFF units).

3.2.7. Method of Operation: The preferred method of operation is electrical which should have its own source of energy for triggering, ideally with provision for checking the integrity of the systems triggering circuit.

3.2.8. Mechanically operated systems, if used, should be fitted with 'Total Discharge' valves (i.e. ones that continue to discharge even if the operating mechanism should fail after triggering).

Hand-held extinguishers which have been adapted, by addition of pull-cables, rarely have the capability of being operated in varying positions and are not acceptable.

3.2.9. Weight checking: Extinguisher systems should be capable of being dismantled for the purpose of checking the weight of the extinguishant and the integrity of the cylinder, also to enable the operating system to be serviced without discharging the contents. The tare weight of the unit must be marked on the cylinder.

3.2.10. Installation: Particular attention should be paid to the installation and maintenance of any system, especially if it is mechanically operated. Pull cables should be fitted in such a way that no kinks or 'S' bends are formed which could cause malfunction.

3.2.11. A list of plumbed-in extinguisher kits that are approved by the MSA is available on request.

3.3. During events:

3.3.1. All plumbed-in extinguisher systems must be in an 'ARMED' condition (i.e. be capable of being operated without the removal of any safety device) at all times whilst competing or practising in races or speed events (including during post-event scrutineering), and at all times that crash helmets are worn on rallies (i.e. on Stages etc.).

3.3.2. Any plumbed-in extinguisher system found to be incapable of being operated will be the subject of a report to the Clerk of the Course/Stewards for possible penalty as an offence against Safety Regulations.

3.3.3. Checking for correctly 'Armed' extinguisher systems, should only be carried out by MSA Scrutineers, and/or Judges of Fact nominated for that purpose.

3.4. Hand-held extinguishers

3.4.1. Must not be carried loose but should be retained in positive quick release brackets, secured to the vehicle by a minimum of two 6mm bolts.

3.4.2. Extinguishers with pressure gauges are recommended.

3.4.3. The tare weight of the unit must be clearly marked on the cylinder.

3.5. General

It is recommended that all fire extinguisher bottles be securely mounted within the main structure of the vehicle. It is prohibited to mount bottles of over the medium capacity outside the main structure.

Safety Fuel Cells

4.1. The FIA approved standard for Safety Fuel Cells is FIA/Spec./FT.3 and FT.5. Fuel cells complying with this standard are only manufactured by authorised

companies and bear the name of the company, specification, code and date of manufacture stencilled on each cell. No other cells are approved by the FIA.

4.2. Under FIA regulations the homologation expires once the cell is five years old. The validity of this homologation may be extended for a further two years if the cell is inspected and recertified by the original manufacturer.

4.3. It is recommended that any safety cell is periodically inspected on a regular basis.

Red Warning Light

5.1. A rearward facing red warning light of a minimum of 21 watts, with surface area minimum 20cm², maximum 40cm², or of 21 watts with a surface area minimum of 50cm² and with lens and reflector to EU Standards, must be located within 10cm of the centre line of the vehicle and be clearly visible from the rear. Vehicles fitted with full width bodywork may alternatively use two lights equally located about the vehicle centre line. An alternative light unit of equal or enhanced constant luminosity or LED lights that are either homologated by the FIA or comply with relevant EU Regulations may be used.

5.2. The warning light must be switched on when visibility conditions are reduced, or as detailed within championship and/or event regulations, or when so instructed by the Clerk of the Course.

Tank Fillers, Vents and Caps

6. Tank fillers and caps must not protrude beyond the bodywork or be situated within the driver/passenger compartment. The caps must have an efficient locking action to reduce the risk of opening during an accident and to ensure closing after refuelling (14.1.2). Air vents must be at least 25cm to the rear of the cockpit and must be designed to prevent the escape of fuel should the vehicle be inverted. It is recommended that a non return valve is incorporated in the vent system. The entire fuel tank area 'Licked by the open air stream' must incorporate a crushable structure as follows:

Crushable Structure

7.1. The crushable structure should be a sandwich construction based on a fire resistant core of minimum crushing strength 25lb/sq in. It is permitted to pass water pipes through this core.

7.2. The minimum thickness of the sandwich construction must be 10mm. The fore and aft fuel tank area, however, must provide for a crushable structure of at least 100mm thickness at its thickest point, the position of this widest point to be at the constructor's discretion, over a length of at least 35cm after which it may be generally reduced to 10mm.

7.3. The sandwich construction must include two sheets of 1.5mm thick aluminium sheet having a tensile strength of 14 tons/sq in and minimum elongation of 5%.

7.4. All oil tanks mounted outside the main chassis structure must be surrounded by crushable structure of minimum thickness 10mm.



CARTEK electronic Battery Isolators are a very small and highly reliable alternative to the traditional mechanical master-switch.

They have been designed to overcome all of the problems and restrictions associated with mechanical and electro/mechanical master-switches to maximise reliability, enhance safety save weight and simplify installation.

FEATURES

- Fully electronic with no moving parts
- Totally sealed against water and dirt
- Completely resistant to shock and vibration
- Fully integrated with built in alternator run-down circuitry -
No extra components required
- Driver operation by a single internal ON-OFF button/switch
- External operation by single or multiple 'strike' button(s)
- Buttons / switches connected to Isolator using light weight wiring
- Mounts close to battery for reduced cabling
- Very small and weighs just 70g - 140g
- Designed and manufactured in UK using the latest and best quality components available

USED BY



OPEL ADAM R2



GINETTA LMP3



McLAREN 570S GT4



MINI CHALLENGE UK

When fitted to race cars, our Solid State Battery Isolators simultaneously isolates the battery and kills the engine immediately when triggered in accordance with [FIA & MSA safety regulations](#).

CARTEK Battery Isolators can be supplied unit only for connection to customers' own switches/buttons or as full kits with high quality, fully waterproof, buttons and safety stickers.

This system has been designed to simplify installation thereby saving time and reducing build costs.

FIA RAIN LIGHTS

CARTEK also manufacture high quality Rain Lights to meet the latest FIA specification and used by race car manufactures such as McLaren, Porsche, KTM.



For more information please go to :

www.CARTEKMOTORSPORT.com

(K) Competitors: Safety

External Circuit Breaker

8.1. The circuit breaker, when operated, must isolate all electrical circuits with the exception of those that operate fire extinguishers.

8.2. The triggering system for the circuit breaker on saloons should be situated at the lower part of the windscreen mounting, preferably on the driver's side or below the rear window.

8.3. On Open Cars the triggering system should be situated on the lower main hoop of the Roll-over Bar on the driver's side or at the lower part of the windscreen mounting (as above).

8.4. Alternatively on cars of Periods A to F the mounting point may be mounted approximately vertically below the line of the scuttle on the driver's side.

8.5. The triggering system location must be identified by a Red Spark on a White-edged Blue triangle (12cm base), and the 'On' and 'Off' positions clearly marked.

Overalls

9.1. Clean Flame-Resistant overalls, must be worn to cover from ankle to wrist to neck.

Acceptable standards:

9.1.1. Racing:

FIA 8856-2000

9.1.2. Special Stage Rallies, Sprints and Hill Climbs:

FIA 8856-2000

FIA 1986 Standard

9.1.3. Karting:

As defined in U.13.3.

9.1.4. All Other Events (including overalls in accordance with Q.13.1.2):

BS6249 part 1 Index A or B (but not part C).

BSEN533

EN533:1995 Index 3

ISO 14116

FIA 8856-2000

FIA 1986 Standard.

9.1.5. For FIA Standard Overalls the homologation label will be stitched into the fabric of the garment or on a sewn in label. For International use overalls must comply with: FIA 8856-2000

9.1.6. As with any item of safety equipment, evidence of damage or excessive wear can render it unsuitable for use. In the case of overalls this could include over frequent, or incorrect, washing, broken seams or stitching and worn patches. Two piece overalls should be avoided, but if worn must overlap and provide flame resistant coverage.

9.1.7. Due to the complex nature of national test standards and variations of detailed testing it is not possible to quote 'equivalents' from foreign national standards unless they are FIA approved as detailed above.

National test standards are in the process of being superseded by European norms (CE Marks), which will provide a common standard throughout Europe.

9.1.8. Individual competitors are responsible for ensuring their own safety and that appropriate flame resistant overalls are worn when mandatory.

9.1.9. Competitors are also strongly advised to wear Flame Resistant gloves, socks, balaclavas and underwear.

Plastic shoes (such as trainers) should be avoided.

9.1.10. Specific regulations concerning Flame Resistant gloves, socks, balaclavas and underwear are published by the FIA and applicable to International events.

9.2. Exceptionally, drivers of three wheeled cars, competing in accordance with A2.2.1 may wear ACU or FIM approved leather overalls.

9.3. When a name appears on a driver's helmet or overalls, this must be the name of the person wearing them.

Crash Helmets

10.1. Crash helmets bearing an MSA approval sticker must be worn at all times during training, practice and competition. The user must ensure that the helmet is to a standard currently specified (10.3.1), that it fits properly, is secured properly and that it is in a serviceable condition. It is strongly recommended that a flame resistant balaclava, helmet bib or face mask also be worn.

10.2. Total protection can never be given by any headgear, and the best of crash helmets may not entirely prevent head injury or death in a severe accident. Helmet users must understand that helmets are deliberately constructed so that the energy of a severe blow will be absorbed by the helmet and thereby partially destroy it. The damage may not be readily apparent; it is essential therefore that any helmet receiving a blow in an accident is either replaced or returned to the manufacturer for competent inspection - this of necessity must be the responsibility of the helmet user, who will have been aware of the circumstances under which the helmet was struck. It is not possible nor indeed reasonable to expect the scrutineer, in every case, to observe significant damage. Where there is any doubt about the helmet's fitness for its intended purpose then the Chief Scrutineer is empowered to remove the MSA Approval Sticker and impound the helmet for the duration of the meeting. This should be a rare occurrence since competitors must appreciate that, once a helmet has served its purpose, it is not only sensible but necessary to replace it. It is the competitor himself who must ensure that the helmet which he uses is fully fit for its purpose; it is clear that this is a small insurance to pay for one's life. The competitor also might consider that, should he survive an accident, but receive head injuries having knowingly used a previously damaged helmet, he could be placing an enormous burden of care upon his family.

10.2.1. Impounding of helmets

Case 1 Pre-Event. If the helmet does not conform with the required Standards or is in a poor or dangerous condition, the Chief Scrutineer will impound the helmet for the duration of the Meeting, removing the MSA sticker. At the close of the Meeting the helmet will be returned, as received, with the exception of the MSA sticker, to the competitor concerned.



RACEWEAR MANUFACTURER

01233 638498 / 628929



Sabelt

AWS



SFI 3.2A/5 Racewear, FIA Racewear,
Proban FR overalls, Mechanics, Promotion, TV,
Historic racewear, Marshal wear, Kart suits,
Track day kit, Helmets, Boots, Gloves, Fire retardant
Underwear sets, and much more!

awsracewear.com



FIA 8856-2000 SPEC RACEWEAR
BESPOKED  MADE TO MEASURE  REPAIRS



awsracewear.com

AWS Racewear
120/131 Ellingham Ind Est
Ashford, Kent TN23 6LZ
T +44 (0)1233 638498

(K) Competitors: Safety

Case 2 Accident during the Event. If the competitor is injured and the helmet is damaged, the Chief Scrutineer will impound the helmet and remove the MSA sticker then seek the advice of the Steward as to further action.

Case 3 Accident during Event and competitor evacuated to hospital with head injuries. The Chief Scrutineer will make sure that the helmet has been seen by the Chief Medical Officer, he will then impound the helmet and remove the MSA Sticker. Unless the Chief Medical Officer wishes to retain the helmet it must be despatched to the Technical Department at the MSA. Unless specifically called for by the competitor it will be disposed of after six weeks.

10.3. The competitor is reminded of the following essential criteria when buying or using his helmet:

- (a) Correct Standard.
- (b) Correct Fit.
- (c) Security.
- (d) Condition.

10.3.1. Standards. Helmets bearing one of the under mentioned 'standards' may be approved by the MSA subject to other criteria being met. See also drawing 10.3.1.

- (a) ALL MSA NATIONAL EVENTS
- FIA 8860-2004 (Not valid after 31.12.20)
- FIA 8860-2010
- FIA 8859-2015
- SNELL SA2005 (Not valid after 31.12.18)

SNELL SA2010 (Not valid after 31.12.23)
SNELL SA2015 (Not valid after 31.12.23)
SNELL SAH2010 (Not valid after 31.12.23)
SFI Foundation 31.1A, 31.2A (Not valid after 31.12.2018)

(b) In addition the following are acceptable for:
MSA National Kart Racing Events (with exception of Kart Drivers under 15 years of age, Cadet and Bambino Drivers) and MSA National Junior Drag Racing:

SNELL K2005
SNELL K2010
SNELL K2015
SNELL - FIA CMR2007
SNELL - FIA CMS2007

(c) For all International Events please refer to the FIA Regulations.

Kart Drivers under 15 years of age, Cadet and Bambino Drivers. The weight of the helmet may be checked at any time during an event and must not weigh more than 1,550g:

SNELL - FIA CMR2007
SNELL - FIA CMS2007

Part of the approval procedure is to affix an MSA sticker to the outside of the helmet in the approximate location of the driver's right ear.

Stickers may only be affixed by selected scrutineers, by the MSA at Motor Sports House, or by selected

Motor Sports House

OPEN

Monday - Thursday

9.30 - 5.30

Friday

9.30 - 5.00 (phone enquiries 10.00 - 5.00 please)

Tel: 01753 765000 Fax: 01753 682938

Licence Section:

Tel: 01753 765050 Fax: 01753 685426

Website: www.msauk.org

NG

nickygrist.com

Nicky Grist Motorsports



Stilo
UK Importer

TURN ONE
UK Importer



Nicky Grist Motorsports Limited, Unit 5B, Westwood Industrial Estate, Pontrilas, Herefordshire HR2 0EL

01981 241040 | nickygrist.com | info@nickygrist.com

(K) Competitors: Safety

manufacturers, after the helmet has been checked for conformity with the standard required and is considered to be in a satisfactory condition.

MSA approval stickers, for which a fee of £2.50 is charged, are printed on foil, and once individually affixed, cannot be reapplied. Note: Stickers supplied since 01/01/08 are individually numbered.

Note that helmet standards are regularly reviewed and updated, and superseded. Standards will periodically cease to be acceptable; hence an element of 'lifing' will always remain.

Helmets approved for use in all disciplines require a blue MSA sticker to be affixed. Helmets which are accepted for use in kart racing only require a green or yellow where applicable MSA sticker to be affixed. These stickers are available from issuing scrutineers.

10.3.2. Fit and Security. To ensure satisfactory fit and security of your helmet, proceed as follows:

- (a) Obtain correct size by measuring the crown of your head.
- (b) Check that there is no side-to-side movement; a helmet should be as closely fitting as possible consistent with comfort.
- (c) Tighten straps securely – the chin strap must be under tension at all times; ensure therefore that the strap cannot slip. Chin cups are prohibited.
- (d) With head forward attempt to pull up the back of the helmet, to ensure the helmet cannot be removed in this way.
- (e) Ensure you can see clearly over each shoulder.
- (f) Make sure nothing impedes your breathing in the helmet and never cover your nose or mouth other than with a flame resistant balaclava or face mask. Helmets with life-support attachments must only be worn if they are connected to a life-support system.
- (g) Never wear a scarf, tie or other loose clothing which could come loose and possibly cause an accident.
- (h) Ensure that the visor can be opened with one gloved hand.
- (i) Satisfy yourself that the back of the helmet provides protection for your neck.
- (j) Do not buy from mail order unless you can satisfactorily carry out the above checks; return a helmet unused if it does not fit.

10.3.3. Condition and Care of Helmet

- (a) The user himself must bear the prime responsibility for ensuring that his helmet is fit for the purpose intended, since significant damage to the helmet may have been sustained without this being apparent to the scrutineer.
- (b) Anything other than minor superficial damage is likely to result in the scrutineer removing the MSA sticker and impounding the helmet for the event.
- (c) It is in everyone's interest for the competitor to buy the best helmet he can and to look after it (the best is not necessarily the most expensive). A helmet bag should always be used.
- (d) There must be no alteration to the structure of a

helmet. Where a radio intercom is fitted this should only be done in accordance with the helmet manufacturer's instructions. Fitment of cameras to helmets by whatever means is not permitted unless an integral camera is provided by the helmet manufacturer and that model of helmet is approved under one of the accepted standards.

- (e) Use only a weak solution of soft soap and water to clean the interior and exterior of the helmet; do not get the interior too wet.
- (f) Some moulded plastic helmets although they meet approved standards can be seriously damaged by substances such as petrol, paint, adhesives, cleaning agents and stickers (not the MSA Stickers) – such damage may not always be apparent; however, crazing or obvious dulling of the surface finish could indicate serious structural weakening of the helmet and is likely to result in the scrutineer removing the MSA sticker and impounding the helmet for the event.
- (g) The helmet should be stored, preferably in a helmet bag, in a cool dry place away from sunlight when not in use. Do not strap the helmet to the roll cage or allow other unrestrained movement which could cause the helmet to be damaged.
- (h) A good helmet, properly cared for, is one very important link in a long chain of safety measures. Do not allow it to become the weak link. Do not rely on others. You are responsible for your own safety. Do not, through your own fault, become a grave burden to others.

10.4. FHR Device

It is permitted to incorporate the use of an FIA approved FHR Device fitted in accordance with FIA regulations and the below.

For MSA National Events in addition to helmets listed by the FIA as recognised for use with FHR, helmets to Snell SA2015 and Snell SAH2010 are accepted subject to the anchorage points being marked as homologated to FIA 8858-2010.

Goggles and Visors

11.1. Either goggles or a visor must be worn at all times during training, practice and competing, unless in a closed vehicle.

11.2. Recommended visor and goggles standard (minimum) BS4110, BS4110:1999, BS EN 1938, European Standard 89/686/EEC.

11.3. Goggles or visors must be clear or neutral density filters.

Front Engined Cars

12. With front engine cars a propeller shaft restraint should be fitted. Either safety hooks or a rigidly fixed steel panel of not less than 18swg.



Motor Sports House

OPEN

Monday–Thursday
9.30–5.30

Friday
9.30–5.00
(phone enquiries
10.00–5.00 please)

Tel: 01753 765000
Fax: 01753 682938

Licence Section:
Tel: 01753 765050
Fax: 01753 685426

Website:
www.msauk.org

**SCHROTH®
RACING**

© McClain Images

HANS XLT

**SCHROTH RACING
CHAMPIONS CHOICE
XLT HANS FAMILY**

Visit www.schroth.com/racing to learn more about our products.

 Follow us on Facebook
www.facebook.com/schrotracing

(K) Competitors: Safety

Head Restraints

13. Head restraints when required to be fitted, must be capable of restraining a 17kg mass decelerating at 5g.

Dimensions to be 10cms x 10cms and located such that the driver's/passenger's head/helmet is restrained and cannot move past it under rearward forces, or be trapped between the rollbar and the head restraint. It is recommended that it be within 5cm of the driver's/passenger's helmet when they are normally seated.

General Safety Recommendations

14.1. Owing to the widely varying nature of competitions and the vehicles taking part in them, the MSA takes the view that it would not be in the best interests of the competitors to cover all aspects of safety precautions with mandatory regulations. Inevitably such regulations could not necessarily provide for the most appropriate safety precautions in all foreseeable circumstances.

The MSA therefore draws attention to the following points so that the competitors can consider them and take precautions as seem appropriate to their own particular requirements.

14.1.1. Electrical

- (a) **Batteries** – precautions should be taken to reduce the possibility of acid burns from batteries in case of accidents. Batteries should be secured within a non-conductive leak-proof compartment.
- (b) **Electrical System** – all wiring should be secured and well protected to reduce the risk of fire from electrical short circuits.

14.1.2. Fuel

- (a) **Fuel Tanks and Pipes** – every effort should be made to isolate fuel tanks and pipes from the driver/passenger compartment. The risk of fuel spillage from accident damage can be reduced by use of bag type tanks or by coating metal tanks with GRP. Tanks should be located so that they are given maximum protection by the structure of the vehicle. Vents should be designed to avoid spillage if the vehicle becomes inverted.
- (b) **Fuel Fillers** – these should be designed and located to reduce risk of damage. Filler caps should not be liable to open in the case of an

accident. Simple screw caps are effective. The positive locking of the fuel filler caps is recommended. The filler pipe to the tank should be of minimum possible length and not protrude beyond the bodywork (6).

14.1.3. Steering Wheels. The types least likely to inflict injuries due to breakage should be selected. Uncovered wooden rims should be avoided.

14.1.4. Fire Extinguishers. Even small extinguishers carried in a vehicle can extinguish or contain fires before they develop seriously. Minimum recommendation is for a 1.75 litre AFFF extinguisher or equivalent with BS4123/EN3 approval (EN3 minimum size is 2 litre AFFF) and a rating of at least 34B. More sophisticated equipment is required in many events and full vehicle systems are highly recommended (see 3).

14.1.5. Seats. See 2.2.

14.1.6. Headrests. See 2.3.

14.1.7. Radiator Caps. These caps should be positioned or shielded in such a way that hot water or steam cannot scald the driver of the vehicle if they become opened or broken in an accident.

14.1.8. Clutch and Bell Housing Protection. It is recommended that a shield be placed to guard the clutch/ bellhousing and to protect in case of clutch/flywheel derangement. This can be a 1/8in steel plate, or sandbag type absorber as used in drag racing.

14.1.9. As a general principal competitors are advised to replace any safety item, helmet, safety harness, seats etc., should they have been involved in a severe accident.

14.2. Paddock Safety. In areas to which the public has access, no engine shall be run with the gears engaged whilst the vehicle has any driving wheels not in direct contact with the ground, unless all moving parts are adequately guarded and, with the exception of Karts, a competent person is seated in the driving seat.

14.3. Heat and Flame Resistant Clothing. Where appropriate and required by specific regulations the FIA standard is shown below, as detailed in FIA Yearbook, Appendix L, Chapter III, Article 2. These standards are advised for all competition use where protective clothing is either mandatory or recommended.

Motor Sports House

OPEN

Monday - Thursday 9.30 - 5.30

Friday 9.30 - 5.00 (phone enquiries 10.00 - 5.00 please)

Tel: 01753 765000 Fax: 01753 682938

Licence Section: Tel: 01753 765050 Fax: 01753 685426

Website: www.msauk.org



GSM
PERFORMANCE

**...FINE TUNED TO
MEET YOUR NEEDS!**

- Over 75 models of sports seats in our dedicated show room
- Europe's largest range of Harnesses, roll cages and safety equipment
- Bespoke seats, trims and re-trimming services available
- Specialist in-store service to ensure you pick the best seat to meet your needs.

NEW - Make GSM your first stop for all your race wear needs



Racesuits



Helmets



Gloves



Boots



Nomex Suits



Kit Bags

Visit: www.gsmperformance.co.uk to learn about all our products and services

GSM Performance Ltd

Unit 5, High Hazles Road, Cotgrave, Nottinghamshire, NG12 3GZ

☎ +44 (0)115 9893488 ✉ sales@GSMPerformance.co.uk

www.gsmperformance.co.uk

GSM
PERFORMANCE

(K) Competitors: Safety

- (a) **Underclothing.** Materials tested to ISO 6940. An indication of this should appear on the front of the upper garment, which must cover the neck.
- (b) **Balaclavas.** Materials tested to ISO 6940. All the part seen in frontal projection when worn to consist of at least 2 layers of minimum 180 gr/m² each. The bottom of the balaclava to meet the requirements in (f).
- (c) **Socks.** Materials tested to ISO 6940. Socks to be half hose (to mid-calf) and made from at least one layer minimum 180 gr/m².
- (d) **Shoes.** To cover the whole foot and ankle. Materials tested to ISO 6940 and fastenings and laces to be of non-fusible material. Soles to be manufacturer certified as resistant to hydrocarbons and to flames. Thread used to be flame resistant. Manufacturers to register all shoe models with the MSA and FIA.
- (e) **Gloves.** Materials tests to ISO 6940. Each glove to be labelled to that effect. Backs of gloves to be

made from at least two layers of 180 gr/m². Thread must be flame resistant and non-melting. Gloves must be fitted at the wearer's wrist and cover the cuff of the wearer's overalls. Manufacturers should register all glove models with the MSA and FIA.

- (f) Where MSA/FIA regulations specify the wearing of protective clothing the labels on overalls and upper underclothing may be verified by the organisers for compliance with regulations.

Officials shall also have the right to examine other articles of clothing subject of regulations upon request. Wearers are warned of the particular vulnerability of neck, wrists and ankles. Balaclavas must extend to enter inside the overalls or undergarment around the neck and not come free whichever way the head is moved. Upper undergarments should have a polo style neck.

Ankles and wrists should always be covered by at least two items of protective clothing.

Appendix 1: Tables and Drawings

Table 3

Minimum quantity of extinguishant (3)

Reference	Description	AFFF	ZERO 2000
3.1.1	Small, hand-operated	1.75 litres	N/A
3.1.2(a)	Medium, plumbed-in, for discharge into both cockpit and engine compartment	2.25 litres	2.25 litres
3.1.2(b)	Medium, hand-operated, for discharge into both cockpit and engine compartment	1.75 litres	N/A
3.1.3	Large, plumbed-in, for discharge into both cockpit and engine compartment	2.25 litres	2.25 litres
3.1.4 (plumbed)	Large, plumbed-in, for discharge into engine compartment	2.25 litres	2.25 litres
3.1.4 (hand-held)	Medium, hand-held for Driver or Rally Co-Driver use	1.75 litres	N/A
3.1.5	Hand-operated for cockpit (International)	2.4 litres	N/A

Drawing 10.3.1

Approval Sticker



Approval Sticker



Approval Sticker





**BUILT WITH PASSION
DESIGNED TO WIN**

AST gives you exactly what you need...

AST Competition dampers have been tried and tested to give the winning formula for your race car. We offer a huge range of dampers to cover all your needs, whether racing in club championships, GT cars or WTTC.

Each damper uses only the highest grade materials, and are meticulously built to the highest standards.

They are available in 2 specifications:

The 3 way adjustable units, with separate high speed and low speed compression circuits and rebound all separate, this is possible by using external canisters which in turn allow for a higher nitrogen gas pressure and increased oil capacity.

The single adjustable units use the same high quality internals, and are primarily designed for championships that have banned the use of external canisters. Both sets come complete with springs and AST aluminium top mounts.



AST Competition dampers feature:

- 45mm inverted damper in Macpherson applications.
- Available in single, 2-way and 3-way adjustable units.
- Non seize height adjustable collars for accurate corner weight set up
- Precise valving ensures maximum grip levels and reduced tyre wear
- Low friction bearings and seals increase damper sensitivity.
- High temperature fluid and high pressure nitrogen filled units eliminate cavitation and fade.
- Built from high quality KTL coated steel and aircraft aluminium for maximum durability
- Fully serviceable



WWW.ASTSUSPENSION.CO.UK

TEL. +44 (0) 1242 236168 SALES@ASTSUSPENSION.CO.UK

(K) Competitor Safety

Drawing 10.3.1

HELMET STANDARDS



SA2005



CMR2007



CMR2007



K2005



K2010



SA2010



SAH2010



SA2015



K2015



SFI 31.1A



SFI 31.2A



FIA



Appendix 2: Safety Cage Drawings

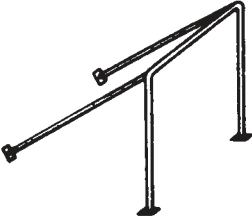

Drawing No. 1

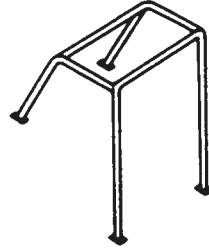

Drawing No. 2

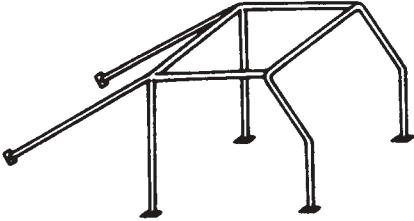

Drawing No. 3

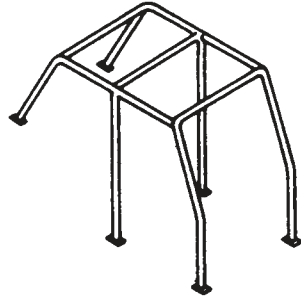

Drawing No. 4

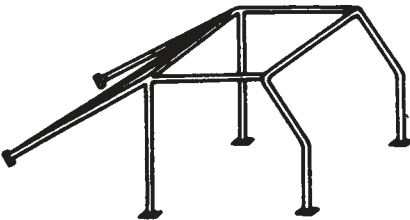

Drawing No. 5

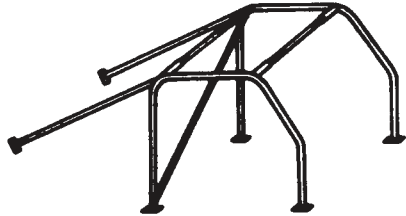

Note: Diagonal may be handed to left or right

Drawing No. 6

(K) Competitor Safety

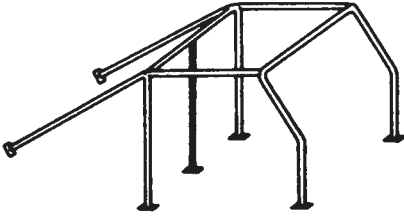

Drawing No. 7

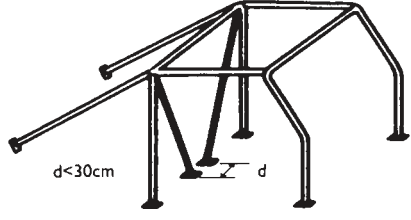

Drawing No. 8

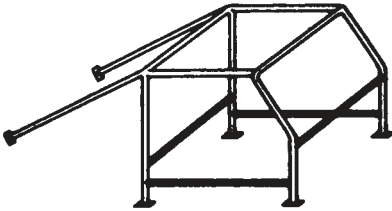

Drawing No. 9

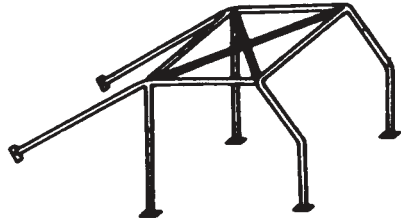

Drawing No. 10

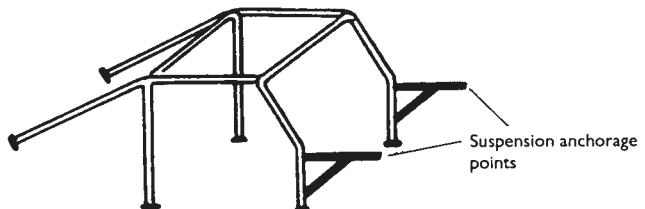

Drawing No. 11

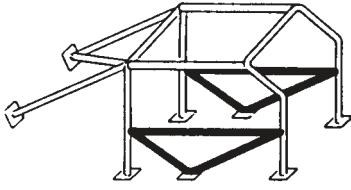

(a)

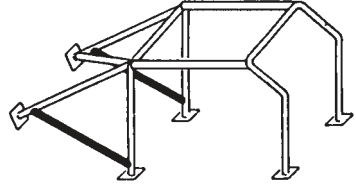

(b)

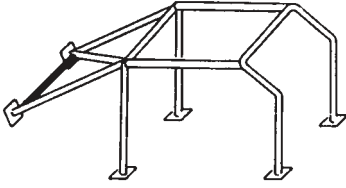

(c)

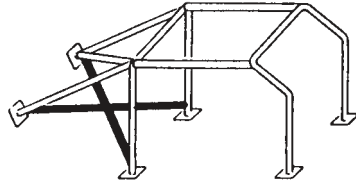

(d)

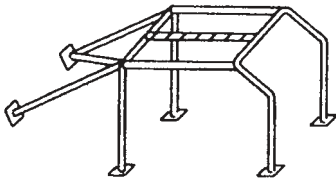

(e)

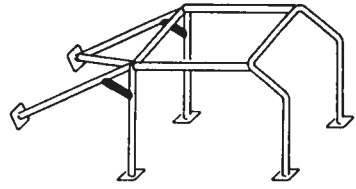

(f)

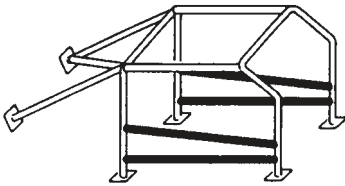

(g)

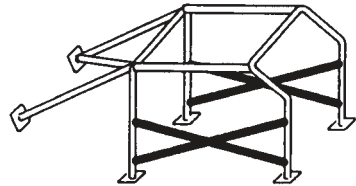

(h)

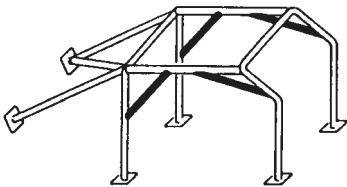

(i)



(j)

Drawing No. 12 Optional Reinforcing Members [6]

(K) Competitor Safety

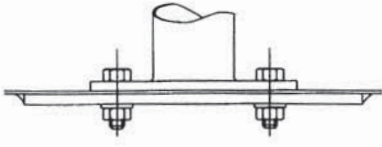

Drawing No. 13

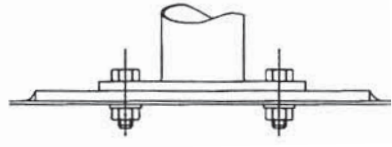

Drawing No. 13(a)

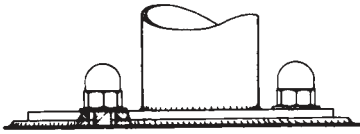

Drawing No. 13(b)

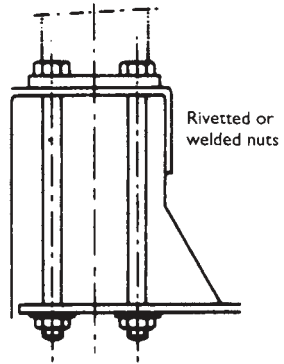

Drawing No. 14

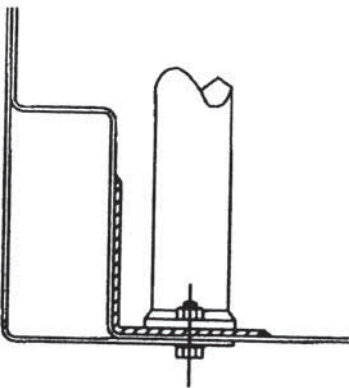

Drawing No. 15

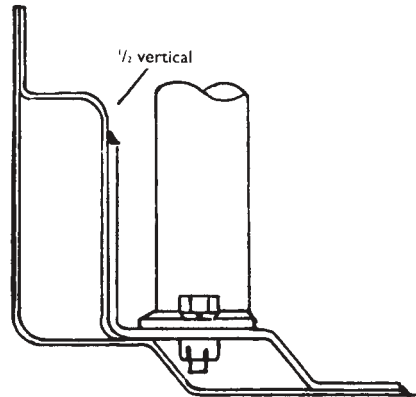

Drawing No. 16

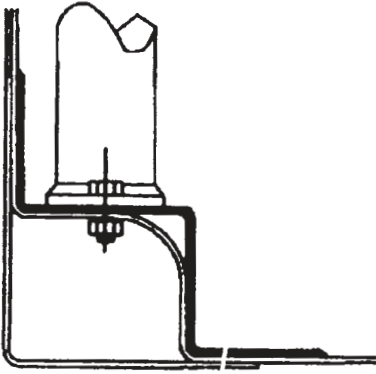

Drawing No. 17

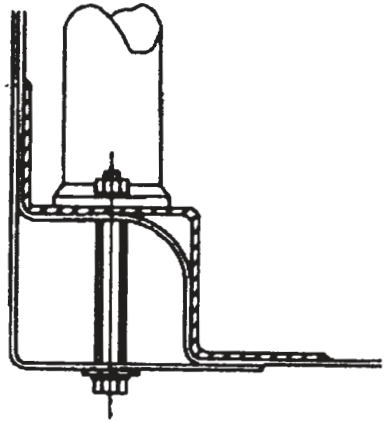

Drawing No. 18

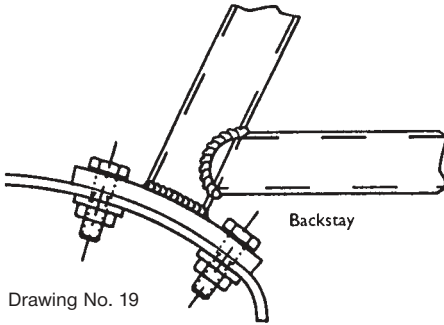

Drawing No. 19

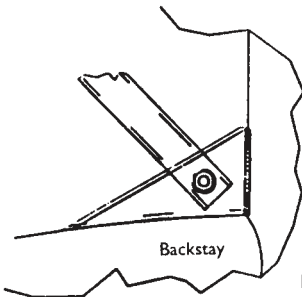

Drawing No. 20

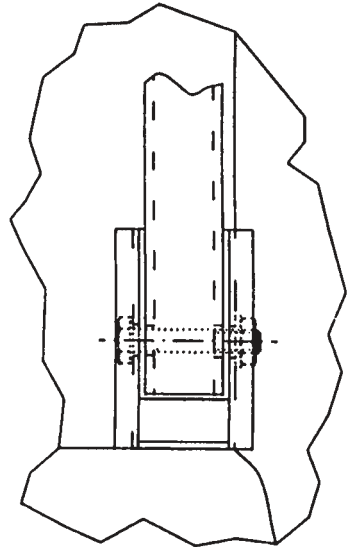

(K) Competitor Safety

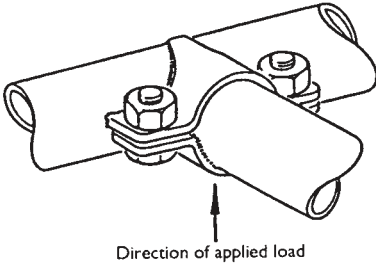

Drawing No. 21

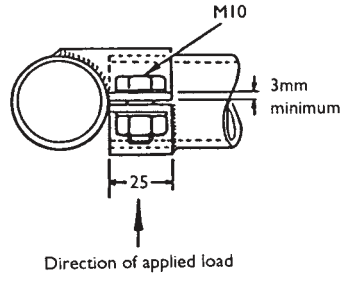

Drawing No. 22

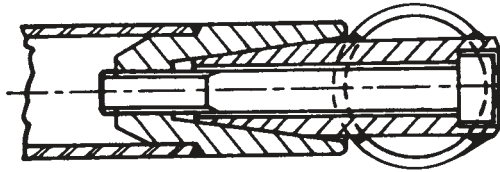

Drawing No. 23

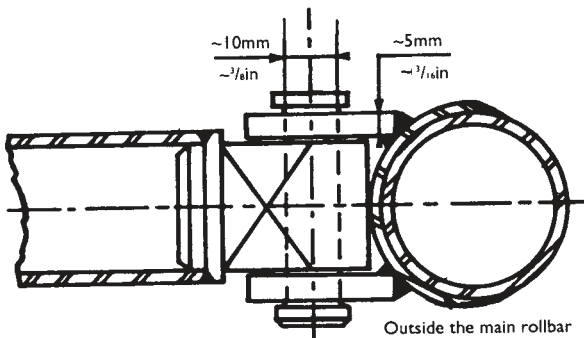

Drawing No. 24

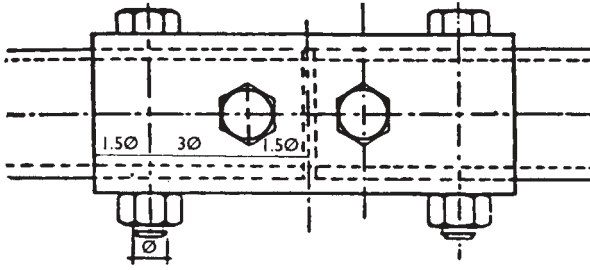

$\varnothing = 14\text{mm}$ (tube $\geq 40\text{mm} < 50\text{mm}$ diam. ext.)
 16mm (tube $\geq 50\text{mm}$ diam. ext.)

Drawing No. 25

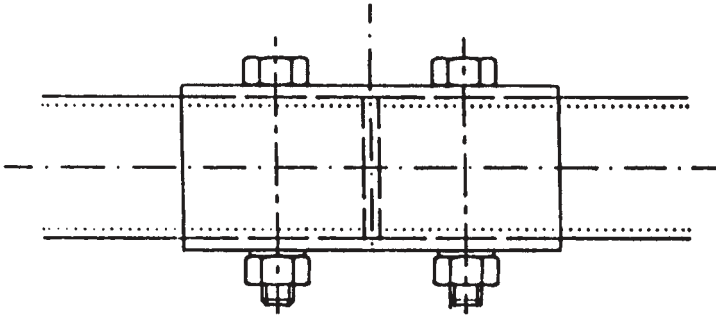

Drawing No. 26

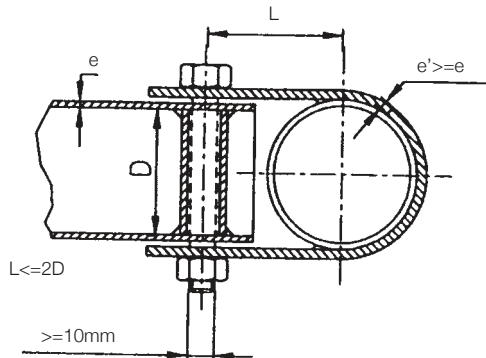

L must be minimum
 The clamp width must
 be at least 25mm

Drawing No. 27

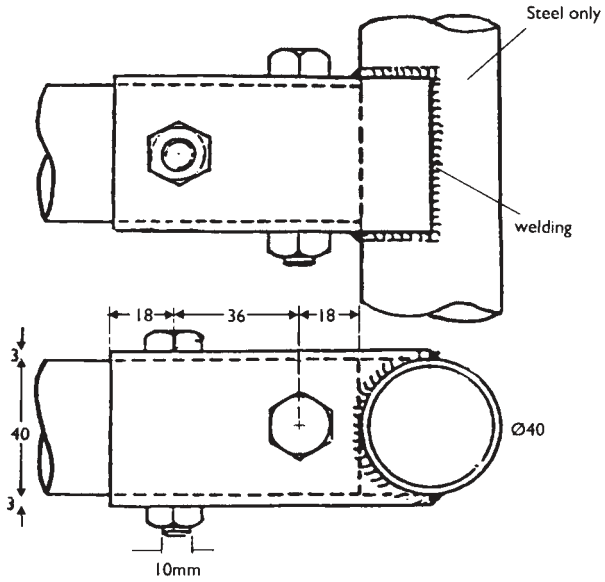

Drawing No. 28

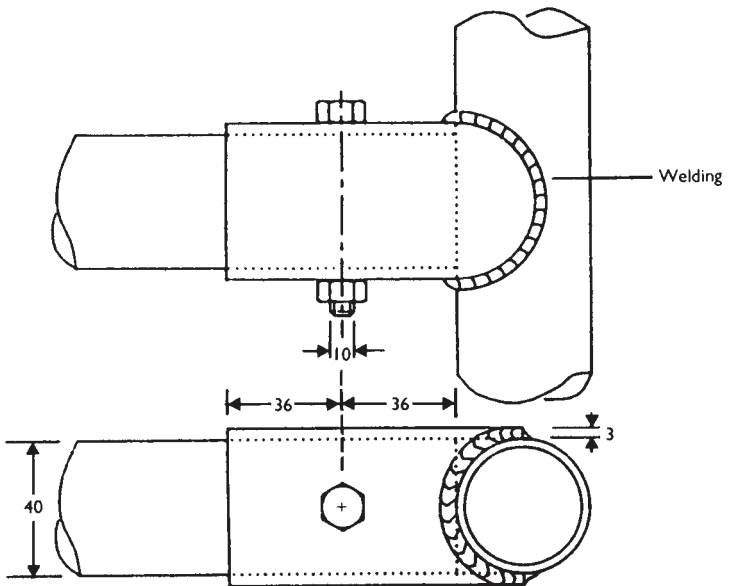

Drawing No. 29

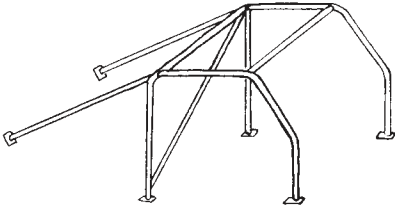

Drawing No. 6(a)

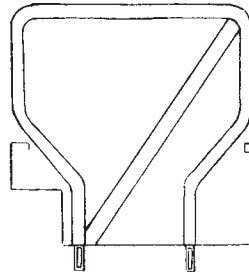

Drawing No. 38

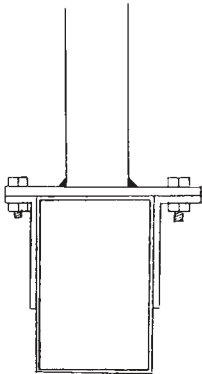

Drawing No. 33

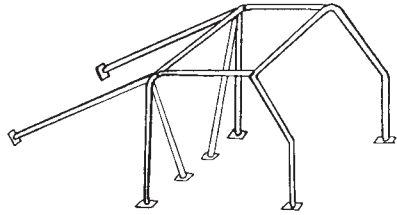

Drawing No. 34

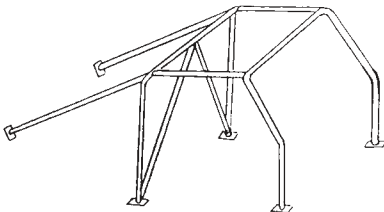

Drawing No. 35

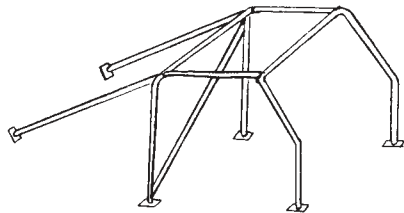

Drawing No. 36

(K) Competitor Safety

a) Diagonal(s) across Main Hoop

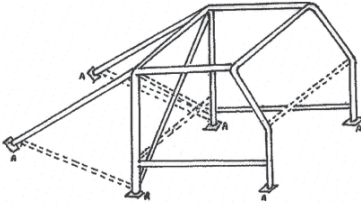

b) Diagonal(s) across Back Stays

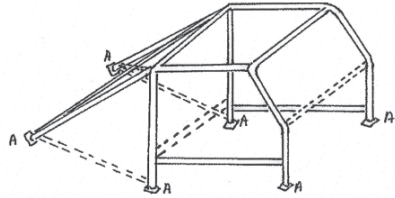

- Mandatory minimum requirement
- Maximum options permitted
- A Mandatory mounting points

Additionally a further 8 points may be attached to the bodyshell.
 Competitors should note that an installation to this drawing may contravene FIA Appendix K regulations.
 Doorbars may alternatively be as shown in figure 12(g) or (h).

Drawing No. 37

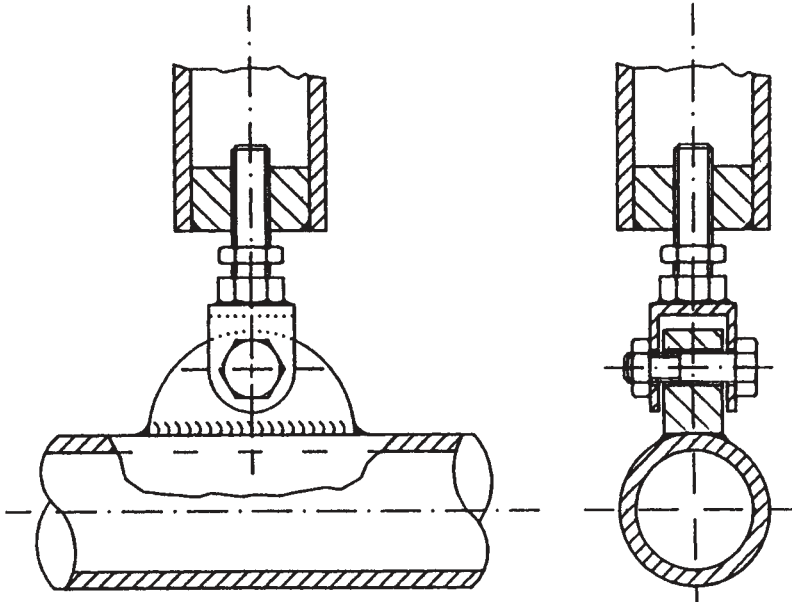

Drawing No. 30

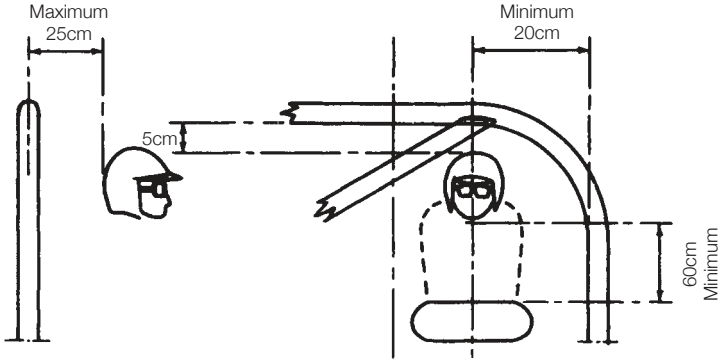

Drawing No. 31

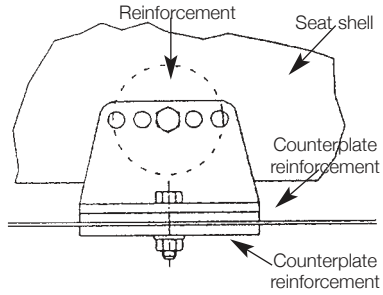

Drawing No. 32

Typical Safety Belt Installation

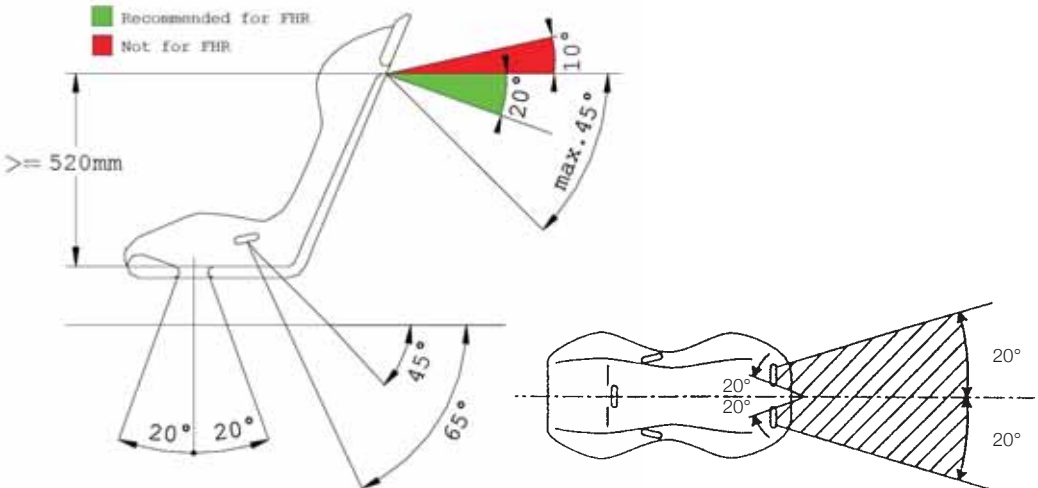

Drawing No. 39

(K) Competitor Safety

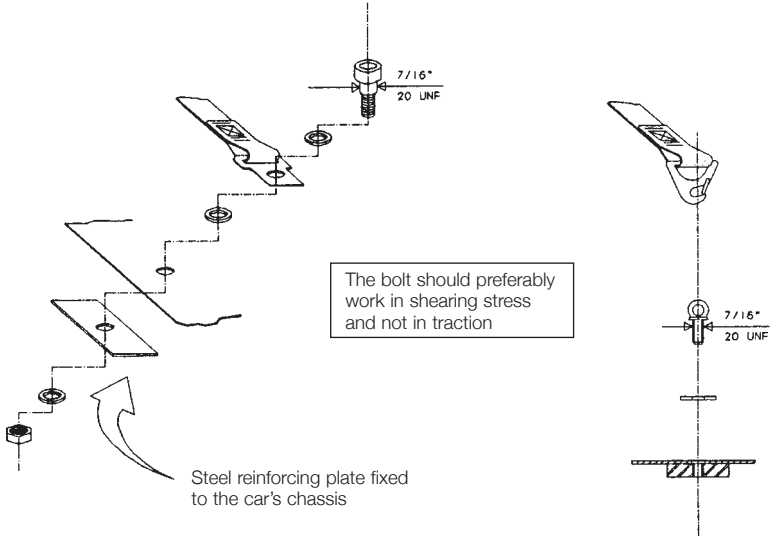

Drawing No. 40

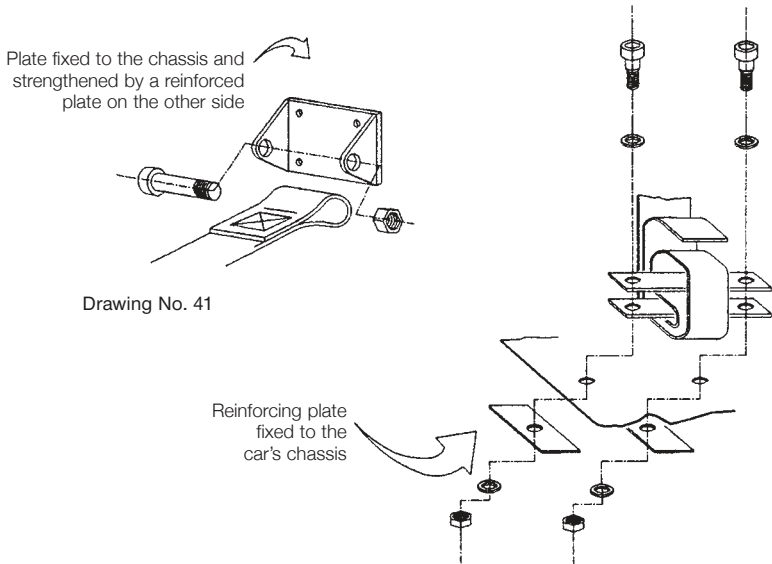

Drawing No. 41

Drawing No. 42

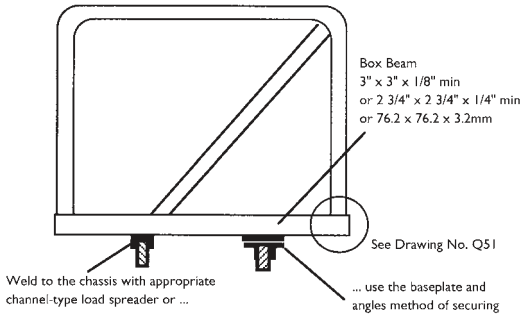

Drawing No. 50

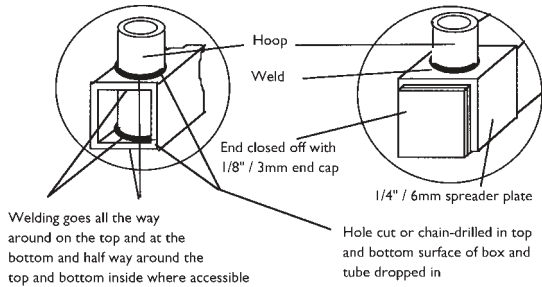

Drawing No. 51

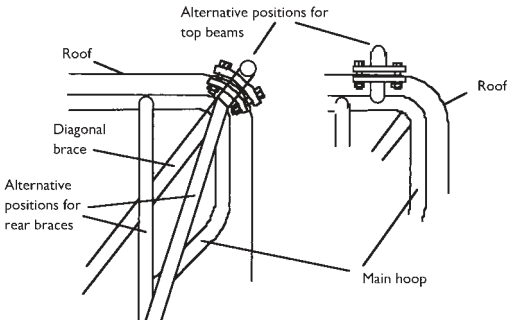

Drawing No. 52

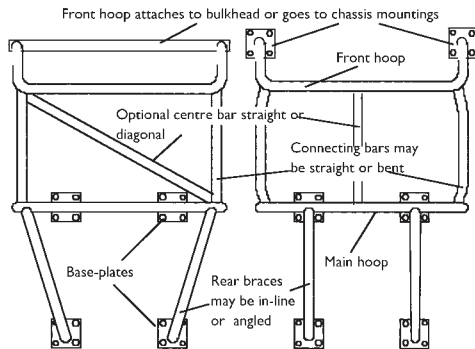

Drawing No. 53

(K) Competitor Safety

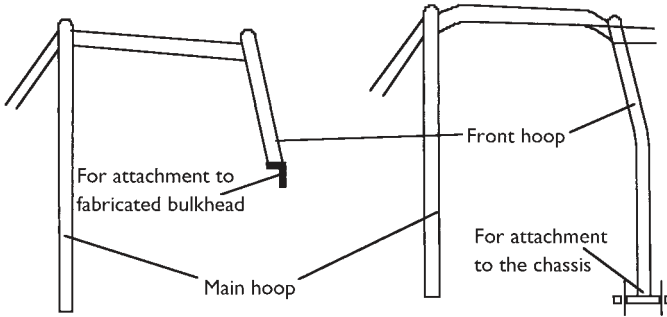

Drawing No. 54

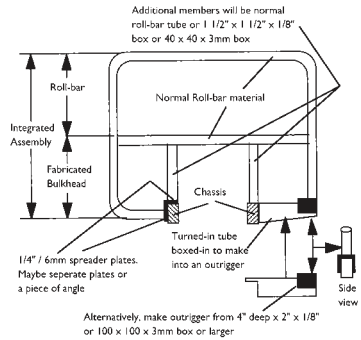

Drawing No. 55

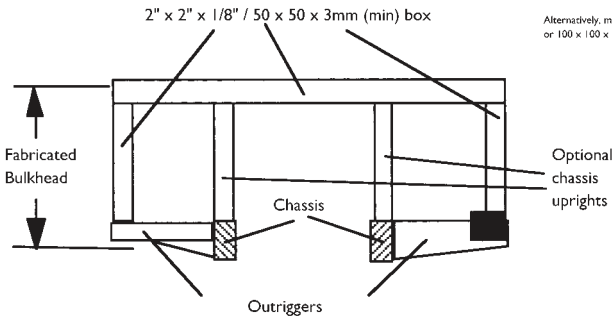

Drawing No. 56

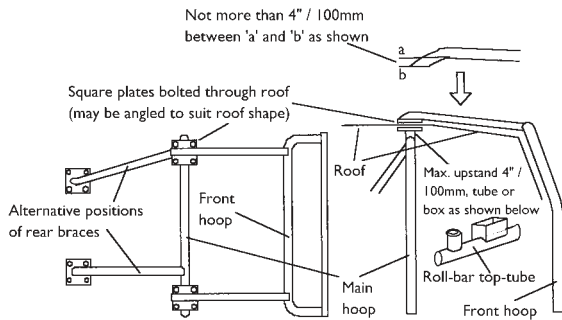

Drawing No. 57

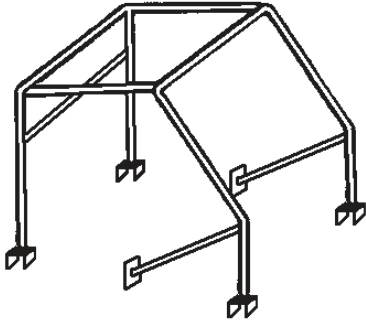

Drawing No. 58

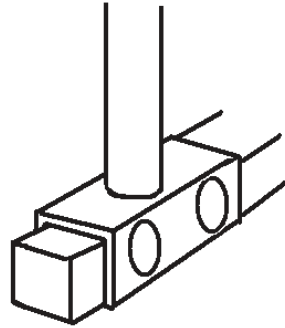

Drawing No. 59

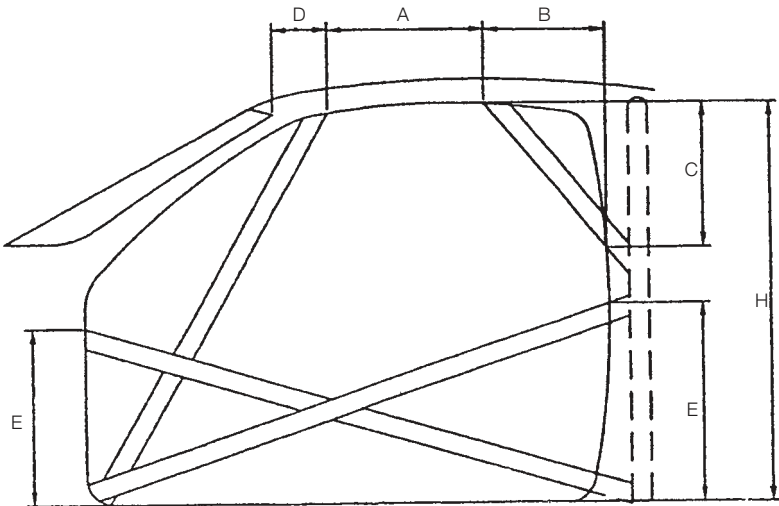

Drawing No. 43

(K) Competitor Safety

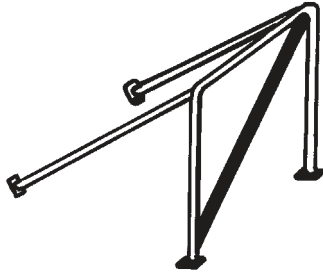

Drawing No. 60(i)

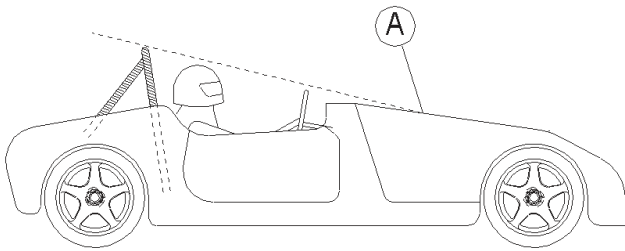

'A' is the substantial structure forward of the driver such as to act as the front rollbar. No part of the driver's helmet is to pass through a line struck from the top of the rollbar to this structure.

Drawing No. 60(ii)

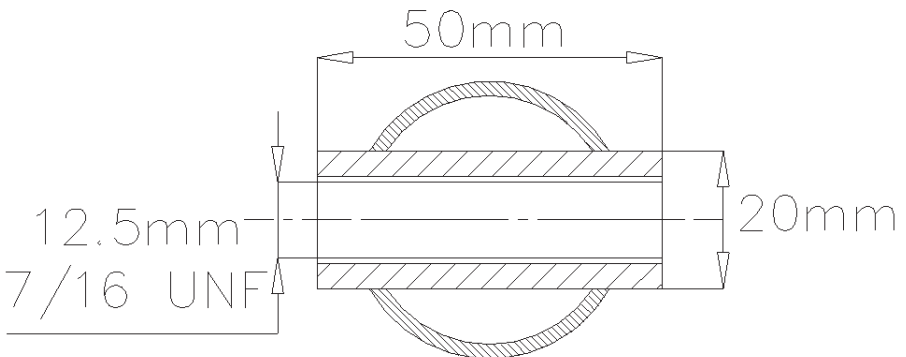

Drawing No. 44

Drawing number 61

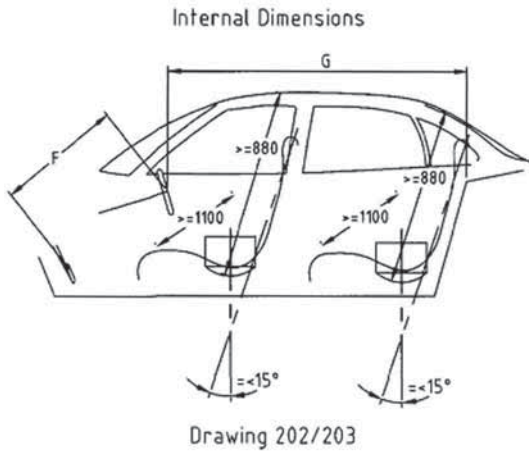

Dimension B Height over front seats (measured between 0° and 15° towards the rear in relation to the vehicle using the test seat weight)

Dimension C Width for the front seats

Dimension D Height over the rear seats (measured as Dimension B)

Dimension E Width of rear seats.

Dimension F Distance from the centre of the hub of the steering wheel to the brake pedal (if the steering wheel is adjustable it must be placed in the median position).

Dimension G Length from the centre of the hub of the steering wheel to the bulkhead of the rear seat, or if possible to the rear face of the rear seat (maximum tilt 15°). If the steering wheel is adjustable it must be placed in the median position.

B and D are measured between the bottom of the seat compressed by the test seat weight, the axis of which is vertical, and the ceiling (padding compressed). If the seats are separate, the measurement is taken in the middle of each of the seats. In the case of

longitudinally adjustable seats, the seats will be placed in the median position. If there is a bench seat in the front, the measurement is taken at 25cm from the centreline of the car.

C and E are the maximum widths measured along the vertical plane passing through the axis of the standard test seat weights placed on the seats, being able to be freely maintained over a height of at least 25cm and a length of at least 40cm. The minimum dimensions (in cm) according to the cylinder capacity (in cm³) are the following, with $H = F+G$

Engine Capacity	Dim. B	Dim. C	Dim. D	Dim. E	Dim. H
From 0 to 1,300	Free	90	Free	90	180
From 1,300 to 2,000	88	110	88	110	200
Over 2,000	93	120	93	120	210

Drawing number 62

