

Origin of Early Harappan Cultures in the Sarasvati Valley: Recent Archaeological Evidence and Radiometric Dates

— K.N. Dikshit*

The paper reviews in a comprehensive sense, the rise of civilization in the - Sarasvati valleys and the adjoining Indus region. The author integrates results (particularly radiocarbon dates) from recent excavation of Harappan sites to reconstruct an archaeological landscape from the 8th - 2nd millennium BCE.

The Sanskrit literature, from the Rigveda to the Puranas, makes mention of the Sarasvati. The Rigveda alone has around 60 references. They make it clear that 'Sarasvati' was the name of a great river on the banks of which the Rigvedic sages lived and composed the hymns. It is because of this, that the river was eulogized in a variety of ways-- as the best of the rivers, as the goddess of learning, as a deity *par excellence*, etc. However, this river is now 'lost' in the deserts of Rajasthan. The problem lies in proving the literary references about this and other Rigvedic rivers on the ground. In recent years archaeology has come forward to prove it with the discovery of a large number of the Harappan sites on the old banks of the dried up course of the Sarasvati. Recent excavations of a few sites in the 21st century revealed older cultures earlier to Harappa civilization thereby

suggesting that Indian Civilization evolved in this region.

THE RIVER SARASVATI

The Ghaggar, Sarasvati, Markanda and Chautang, all rivers rise from Siwalik hills. The hydrographic history of Sarasvati-Ghaggar system of rivers have been studied by a number of geologists such as C.F. Oldham, D.N. Wadia, S.M. Ali, Gurdev Singh, V.M.K. Puri and others (Dikshit 1977: 61-66; Puri 2001: 175-191). They have postulated the changes in their drainage. Burrad and Hayden (Burrad *et. al.* 1907-8; 135-136) were of the view that probably the Giri running between Simla and Chur peaks formerly drained into the Ghaggar but later on deflected to Yamuna because of the slow upheaval of a range across its course (Plate 1).

In 1975, Rajguru and others from

* Chairman, Indian Archaeological Society, New Delhi

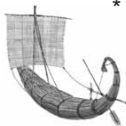

Deccan College, Pune, and Geological Survey of India, Chandigarh carried out geomorphological and archaeological studies in the Markanda valley, a tributary of Ghaggar in Himachal Pradesh. This valley has preserved five river terraces of the post-Middle Pleistocene age indicating that the strong tectonic movements have occurred in the late Pleistocene and early Holocene period. The aerial photographic studies in the adjacent area show lineaments and displacements even in Holocene sediments thereby suggesting continuation of tectonic movements during mid-Holocene times. According to Rajaguru there is evidence about the bifurcation of some of the minor streams originally joining Markanda, a tributary of Ghaggar near Nahan into the drainage of Yamuna (Misra and Rajaguru 1975).

Other channel of river Sarasvati rises in the Siwalik hills of Sirmaur, in the region of the junction of the talus fans of the Yamuna on the east and the Sutlej on the west, joins a tributary called Markanda and then meets the plains at Rampur Herian, 9 km. SSW of Adibadri in Ambala and passes through Karnal. Another river known as Ghaggar also rises from Siwaliks but even at a short distance from the hills, it becomes non-perennial. The Siwaliks feed this river only in the rainy season when its water touches even the towns of Hanumangarh and Suratgarh. After traversing the Siwaliks in the neighborhood of Sirmaur, it leaves the hills near Ambala and meets Sarasvati at Rasula in Patiala. There are three old

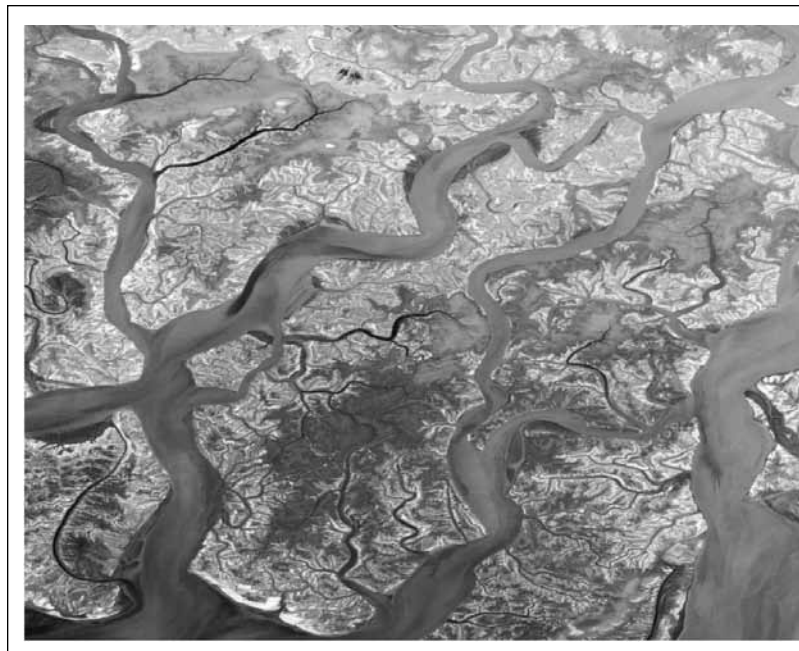

Fig. 1: The Great Rann of Kachchh in the Arabian Sea with salt encrustation in which the river Sarasvati ended itself through various channels

channels of the Sutlej joining the Sarasvati near Kurrulwala. The combined rivers of Ghaggar and Sarasvati flow through Hanumangarh.

The dry course of this river can only be recognized by continuous lines of bordering sand ridges. The flat bed at places is even five to six km wide. The other river Drishadvati or Chautang is very much near the Sarasvati and both the streams flow close to each other upto Kurukshetra and then it takes a south-westerly turn. There are evidence that it passed through Hissar, Bhadra, Nohar and ultimately met combined rivers Sarasvati and Ghaggar near Suratgarh (Plate 2).

From Hanumangarh, a dry bed of the river Naiwal can also be seen starting and meeting again the combined rivers near Anupgarh on Pakistan border. In



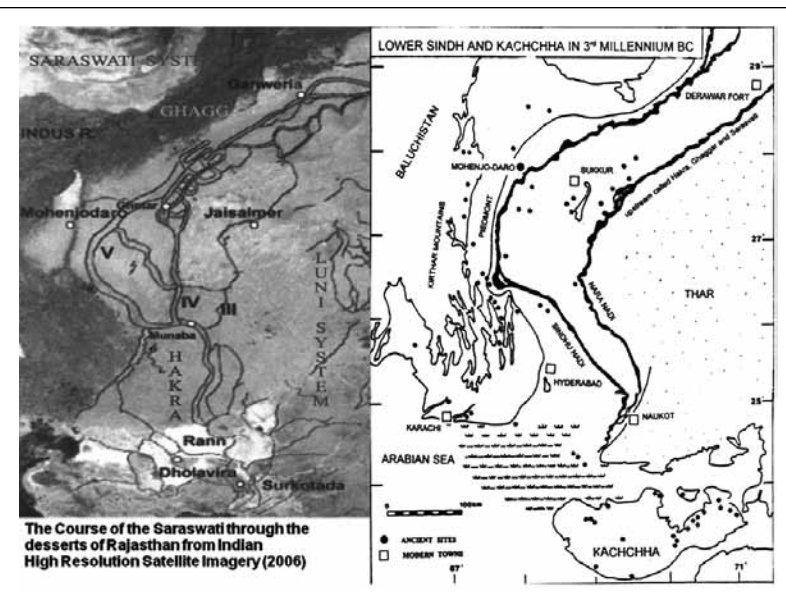

Fig. 2: High Resolution Satellite Imagery showing the course of river Sarasvati

all probability this combined river which is known as the Hakra (or Wahind) in adjoining Pakistan is a continuation of Sarasvati-Ghaggar combine. In 1887 R.D. Oldham and in 1893 C.F. Oldham had figured it out through their two maps with dotted lines. However, the signature of this river beyond Fort Derawar in Cholistan has been obscure under the huge sand-dunes even in the 19th century.

According to Oldham the Sutlej occupied the dry bed of the present Ghaggar or Hakra as late as the 13th century CE. D.N. Wadia pointed out that during ancient times some interchange took place between easterly affluents of the Indus and the westerly tributaries of Yamuna by minor shiftings of water-sheds and the river Yamuna during early historic times discharged into Indus system through now neglected bed of the Sarasvati river. Tripathi *et. al.* (2004: 1141-

1145) suggested the river became ephemeral due to tectonically induced river piracy.

The isotope data of the Ghaggar alluvium and also of Thar Desert point to a sub-Himalayan sediment source with no contribution from the glaciated regions. It was supported by monsoonal rainfall in the sub-Himalayan catchment, the reduction of which was responsible for the extinction of the river. Explorations done by Aurel Stein (1942:99), Henry Field (1959: vol. 3) and M.R. Mughal (1981:33-42) traced the dry bed up to the region near the Derawar fort where the desert shows a depression which is suggested by salt encrustation in the land and traces of some channels as if the river got divided into small channels.

VIEWS OF LOUIS FLAM

That the Sarasvati, also called Hakra, flowed through the deserts of Sindh and merged into the Arabian Sea (Fig. 1) has been worked out by Louis Flam who explored the southern Sindh area for several years and called it 'Nara Nadi'. He has shown it as an independent river flowing parallel to the Indus river which he has called 'Sindhu Nadi' (Flam 1996:33-51).

From this time period a second and exclusive perennial river, the Nara Nadi, was delineated in the eastern portion of the Lower Indus Basin (Fig. 2). The Sindhu and Nara rivers formed a confluence in the south-eastern portion of the Lower Indus Basin, with the prehistoric coastline located in a more northerly area than that of the present day. The Indus and Sarasvati were also



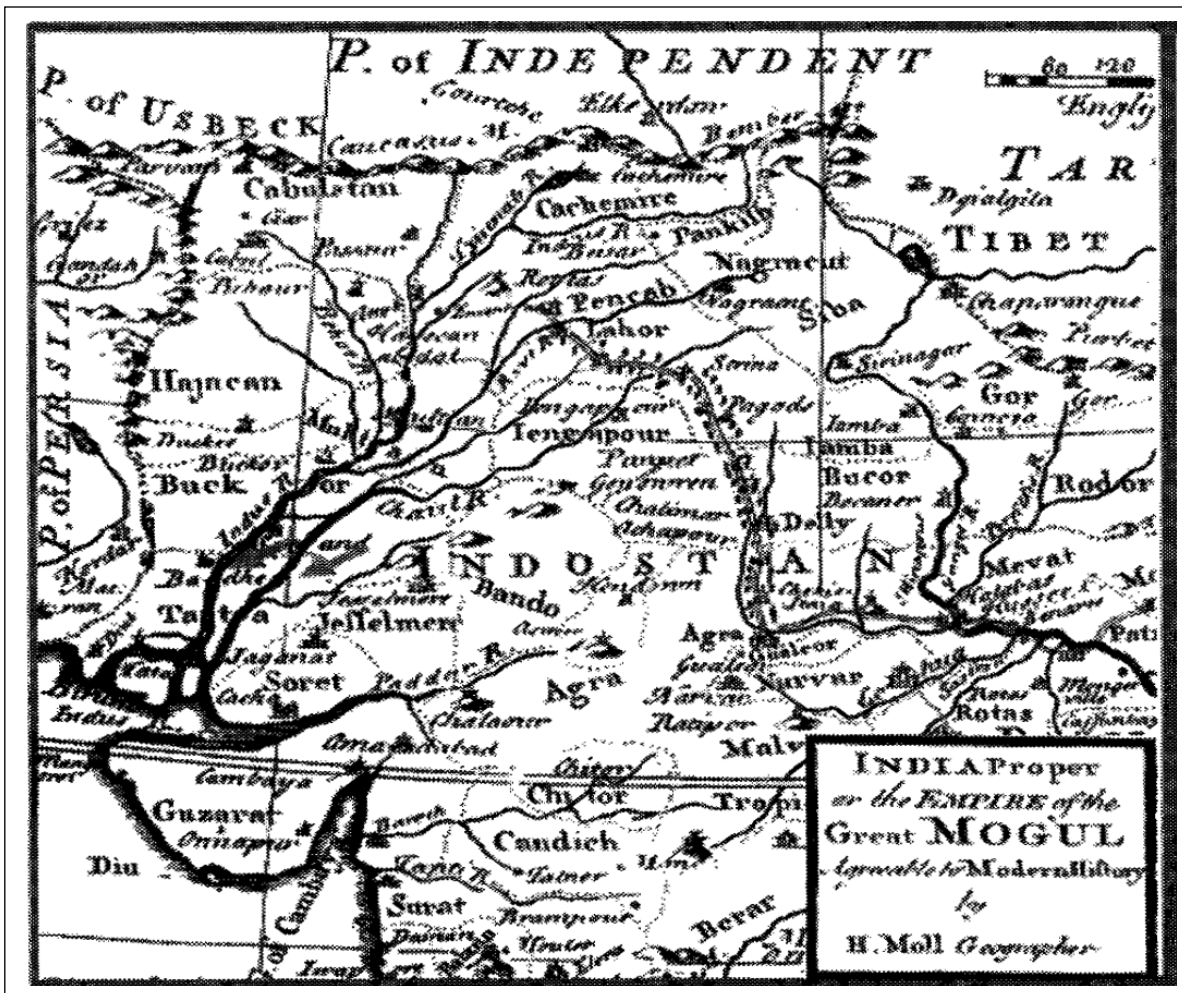

Fig. 3: Indus and Ghaggar (Sarasvati) depicted as parallel river systems - In Moghul period Dutch Map year 1746 (courtesy Wilhelmy 1969, reproduced by J.R. Sharma *et. al.* 2005-06:191)

depicted as parallel river system in Mughal period (Dutch Map, 1746; Fig.3). This has also been confirmed by the High Resolution Satellite Imagery (ISRO, 2006).

IEWS OF POSSEHL

As against the opinions of Louis Flam and M. R. Mughal, Possehl believes that the Sarasvati never reached the sea. He even quotes H. Wilhelmy 1969 for his views. Possehl also quotes Agrawal and Sood, since the Landsat imagery (Yashpal *et. al.* 1984: 491-497)

shows a depression near Beriwala in the area of Fort Derawar. According to Possehl “The presence of the inland delta southwest of Fort Derawar suggests that all, or most, of the Sarasvati’s water was “sopped up” in this area. There seems to be not enough water to push through to the Eastern Nara. During the second and third millennium BCE there is also the lack of physical evidence for a dried river bed between Fort Derawar and the Raini/Wahinda (Possehl 1999:362-387) (Fig. 4).



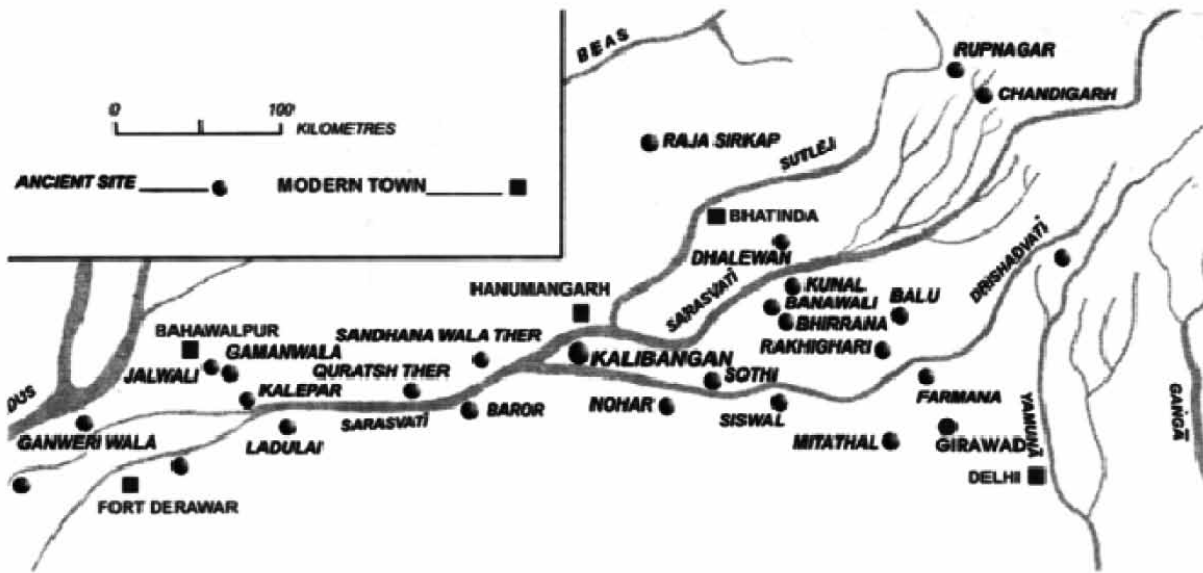

Fig. 4: Distribution of sites in Hakra- Sarasvati basin during 5th – 3rd millennium BCE

LATEST SATELLITE DATA

Recently, a fresh attempt has been made to decipher the course of river Sarasvati from latest satellite data, including hydro-geological and drilling data and also results of isotopic studies carried out by BARC

Mumbai. The findings indicated that the rise in Himalayas and consequent displacements in the Siwaliks and its foothills in the form of Yamuna and Sutlej tear faults was the main cause for ultimate drainage desiccation in the north-western India. It drained through

Major Palaeo Drainage Courses in North Western Region

Simplified map prepared from image mapped palaeo channels

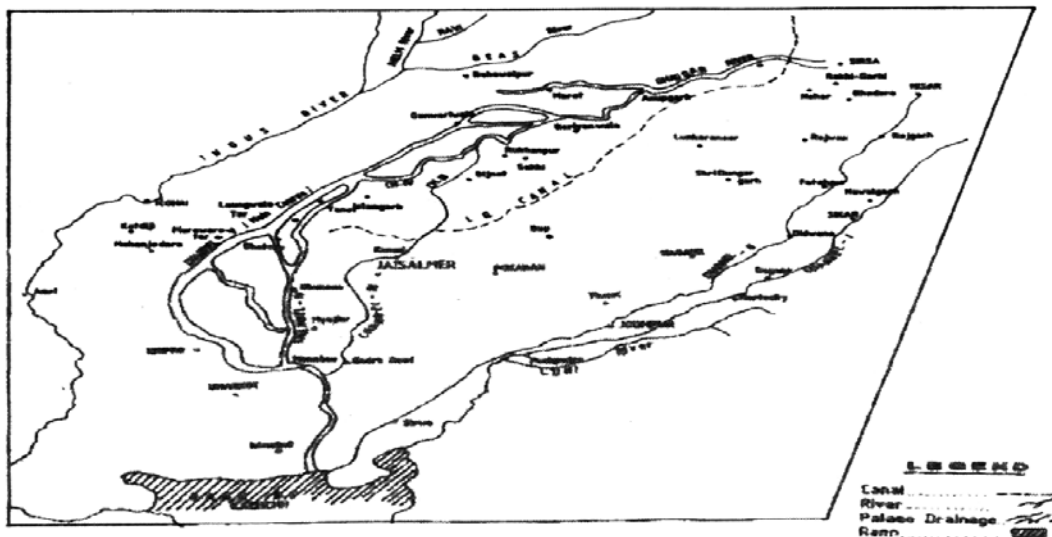

Fig. 5: The Channels meet the Rann of Kutch (courtesy: J.R. Sharma *et. al.* 2005-06).



the present day Ghaggar and was flowing parallel to the river Indus as an independent river system but did not flow through the present course of Nara (Sharma et al. 2006) (Fig. 5).

CLIMATIC EVIDENCE

The proposed phases are based on the palynological data from the lakes in Rajasthan (Gurdeep Singh et. al. 1971:177-189).

Phase I: Before 8000 BCE (wind-borne, unsuitable for human settlement)

Phase II: C. 8000-7500 BCE (rainfall increased)

Phase III: C. 7500 - 3000 BCE (slight decline in rainfall)

Phase IV: C. 3000 - 1000 BCE (increased rainfall in the beginning but a short dry period in the semi-arid belt and towards end a relatively weak wetter interval)

The stratigraphic examination of several other salt lakes such as Pachpadra, Sambhar, Kuchaman, Didwana, Tal Chhapar and Malhar supports the palynological evidence for the increase in rainfall during the Holocene period but the other hypothesis of Singh regarding aridity between 3000 BCE and 1000 BCE responsible for cultural gap is a matter of discussion.

The study conducted by Enzel and others (1999: 125-128) suggests that Harappans survived when the climatic conditions were not conducive. The river basin was connected to a wetter source area in sub-Himalayas. The archaeological evidence does not support such hypothesis as there were other

cultures flourishing such as Ganeshwar or black-and-red ware and also the overlap of the late Harappans with PGW users has been noticed in Panjab and Haryana.

ARCHAEOLOGICAL DATA

Since the discovery of Harappan Culture in 1921, it was in 1958 that a pre-Harappan horizon (now called Early-Harappa) was noticed in a stratigraphical sequence at Kot Diji by F.A. Khan, Director General, Department of Archaeology, Pakistan (Khan 1965: 13-85) and at Kalibangan in 1960-61 by B.B. Lal (IAR, 1960-61, pp. 31-21). At Harappa in 1946 a 'pre-defence' horizon was also noticed by Wheeler (1947: 91).

Since then archaeologists were busy finding the origin of Early-Harappans. Towards the end of 20th century and the beginning of 21st century, a pre-Early Harappan level was confirmed in excavations at Kunal, Bhirrana, Girwad, Farmana and Rakhigarhi, although a pottery termed as Hakra Ware was also noticed in Cholistan area of Pakistan (adjoining India) in explorations only (Mughal 1990: 1-72). However a set of radiometric dates from Bhirrana, Rakhigarhi, Girwad in India and from Mehrgarh in Pakistan confirmed the rise of civilization transforming from the neolithic agro-pastoral stage to the beginning of Chalcolithic Culture somewhere during 7th-8th millennium BCE. The excavations at Kunal (Khatri 1995: 84-86) and Bhirrana in the 'Lost' Sarasvati plain in India, provided for the first time a stage of cultural development from dwelling pits to the





Fig. 6: Map showing the Old World civilization from Indus to Mesopotamia

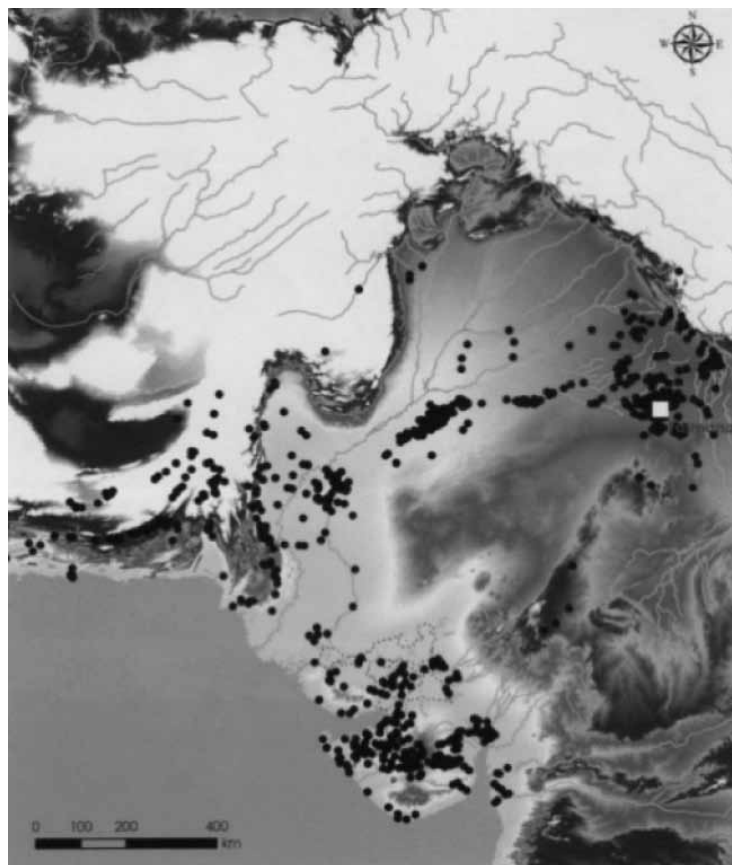

Fig. 7: Distribution of the Harappan sites

primary stage of a settled life (Rao *et. al.* 2003-04, 20-24). The antiquity of Bhirrana on the basis of radiometric dates goes back

to the time bracket ranging in date between c. 7380 – 6201 BCE. This bracket has been calculated on the basis of the calibrated age



range, i.e. 7570 – 7180 BCE on the one hand and 6689 – 6201 BCE on the other.

The above dates put the region of the 'Lost' Sarasvati river in a larger context of the neolithic agro-pastoral stage starting in the west from Anatolia between the 9th - 4th millennium BCE with the limited use of copper as noticed at Cayonu and other neolithic sites in Turkey (Fig.6). These antecedent stages help us in understanding the role of these pre-Harappan cultures (7th – 4th millennium BCE) noticed in the Indus, Hakra- Sarasvati system, lower Sindh and Baluchistan which was followed by a quickening of cultural development which gave rise to the emergence of the urban centres in the beginning of the 3rd millennium BCE (Fig. 6 and 7) from Anatolia to Indus region (courtesy: Randall W. Law) in the Indian subcontinent having concentration in the Sarasvati - Hakra basin (courtesy: Shinde, 2011)

Before taking up the problems of the beginning of the Indian civilization one has to understand the origin of Harappans whose rise was undoubtedly due to an urban revolution from a neolithic pastoral stage. The transformation from Neolithic to early Chalcolithic is still terra-incognito and requires more field work and confirmation from excavations including radio-metric dates to fill up the cultural gap in Indo-Pak subcontinent. The stages of the later Chalcolithic period between c. 4500-3500 BCE are also not clear perhaps due to limited technology or climatic environment in which people lived and produced distinctive

tools for their own use, although in recent years the work done in north Gujarat by the archaeologists of MS University, Baroda deserves attention.

Our knowledge about the beginning of Indian civilization was limited as earlier excavations of neolithic-chalcolithic sites at Kile Gul Mohammad and Rana Ghundai particularly in the north-west region of the Indo-Pak subcontinent were sporadic but the excavations at Harappa in 1946 provided through the cutting of defences, a pre/non Harappan level whose date could not be assigned at that time. After 1947, the lowest levels at Kalibangan, Banawali, Balu, Sothi, Nohar etc. were found comparable with similar results from Kot Diji, Amri,

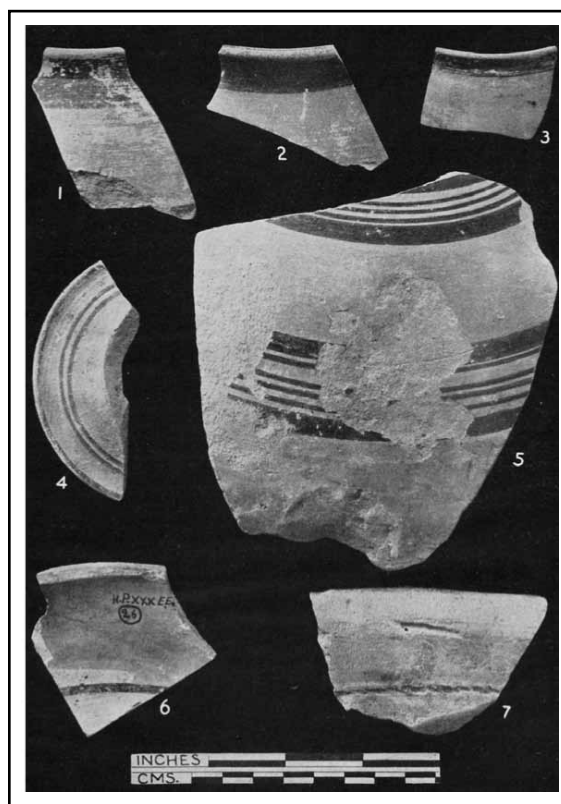

Fig. 8: Harappa: Pre-defence pottery



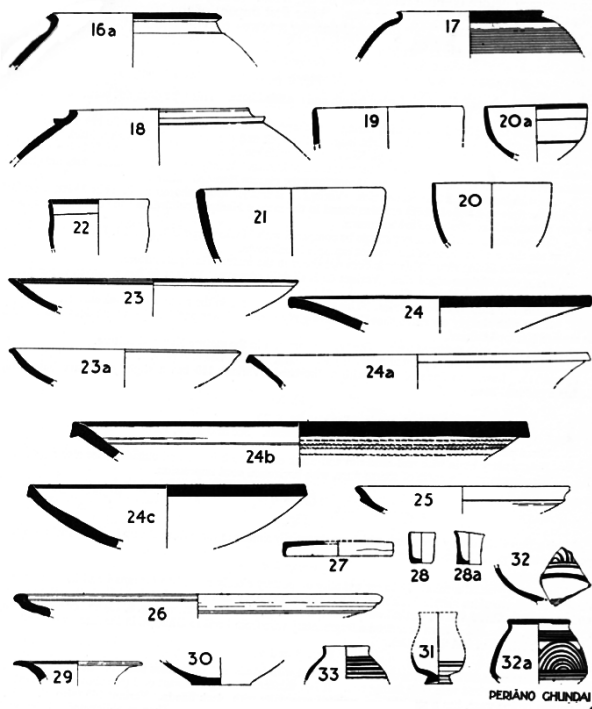

Fig. 9: Harappa: Pre-defence pottery (1946)



Harappa, Pakistan +150 hectares



Hand formed mud bricks

Fig. 10:



Harappa Period 1, Ravi Phase occupation, Mound AB (Courtesy: M. Kenoyer)

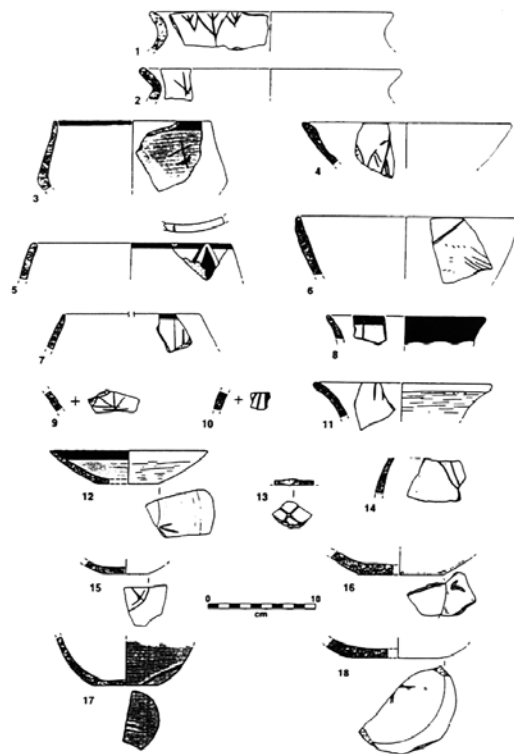

Fig. 12: Harappa: Period 1A (Ravi phase)

Fig. 11:



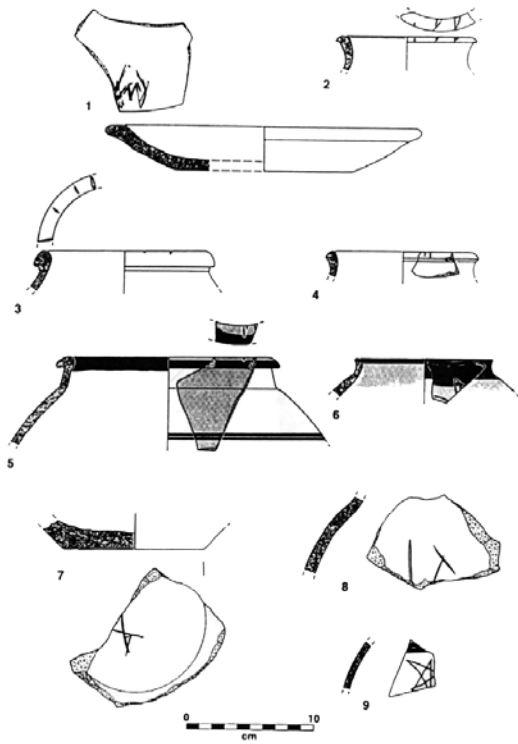

Fig. 13: Harappa: Period 1B (Kot Diji phase)

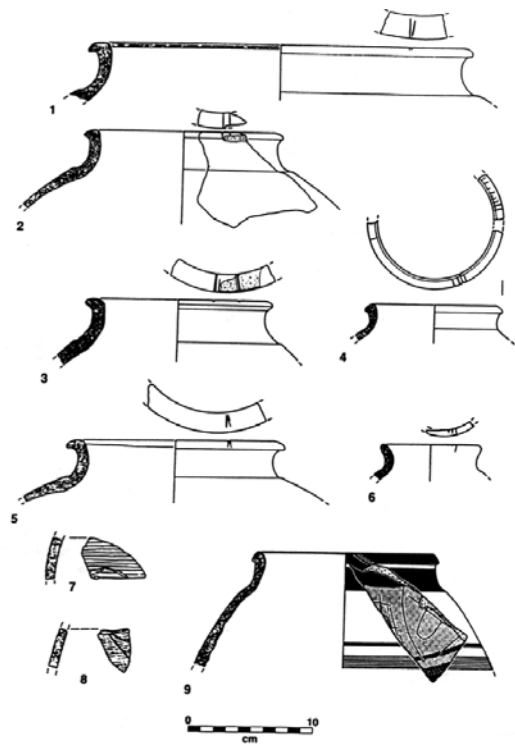

Fig. 14: Harappa: Period 1B (Kot Diji phase)



Fig. 15: Delegation of Indian archaeologists examining the lowest strata of Harappan mound identified as Ravi period (January, 2012)



Harappa, Rehman Dheri and other smaller sites of the adjoining regions. An analysis of the material culture noticed on these sites and also in the hinterland could not push back the antiquity of the region before the beginning of the 3rd millennium BCE. As the present paper is confined to distribution zone of Harappa culture, other areas particularly central Indian chalcolithic cultures namely Kaytha and Navdatoli and transition from neolithic to chalcolithic in Ganga valley particularly Lahuradewa and Jhusi have not been taken into account, although these regions were equally important for their contributions in the origin of Indian civilisation.

DATA FROM PAKISTAN

In Pakistan a particular pottery known as ‘mud appliqué’ ware was found having a wide distribution in the greater Indus region,

Baluchistan and also in Cholistan area of lost river Hakra/ Sarasvati in India which has been termed by Mughal as ‘Hakra ware’. Similar pottery has also been reported earlier from Jalilpur and at a few other places in Gomal plain in regular excavations. Along with this, there are also other decorative potteries with white, red, black or brown paints. The motifs on these wares include floral and geometric and also some birds. This pottery is also associated with a limited use of copper.

HARAPPA

Recent work at Harappa carried out by Kenoyer (2011) revealed Ravi and Kot Diji phases in the lowest level dividing into period IA and IB. He has particularly emphasised on the presence of handmade ceramics in period IA, with the appearance of wheel made pottery in late levels which has been termed

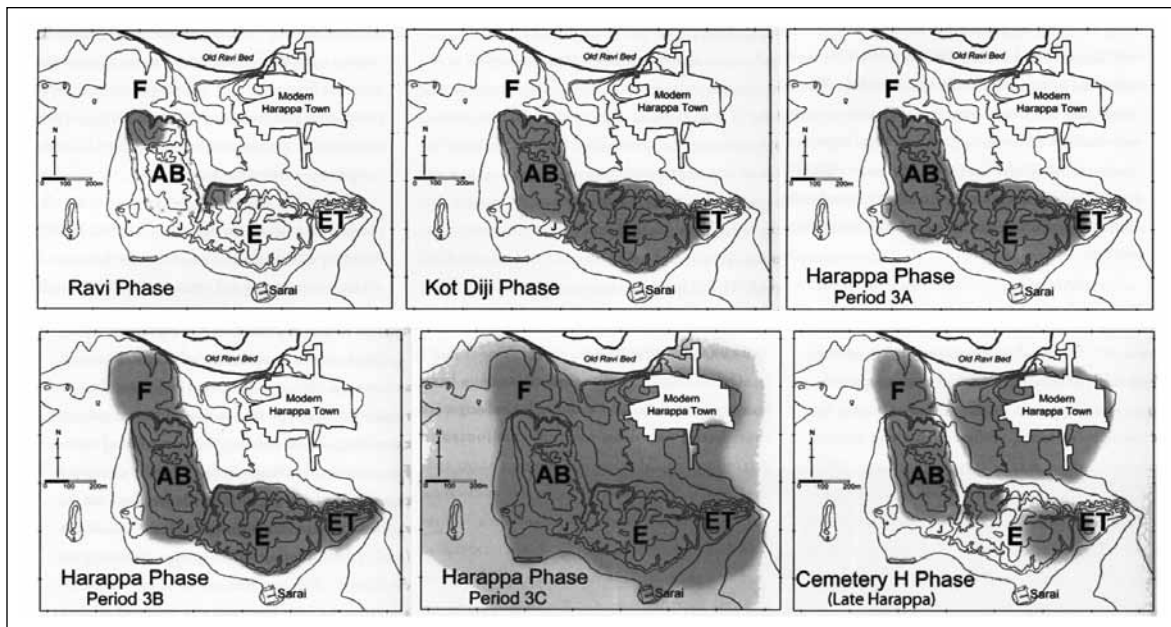

Fig. 16: Harappa: Settlement growth and decline through different phases (courtesy: Randall W. Law)



by him as Ravi phase, whereas in period IB, a small percentage of wheel-thrown pottery along with other fabrics were found (Figs. 8 & 9; Plates 3 & 4). In the later stages of Ravi phase mud bricks were used for building houses (Fig. 10). The pre-defence pottery found earlier in 1946 belongs to period IB (Figs. 11-15).

In the excavations from these earliest levels at Harappa, pottery and other antiquities like cart wheel, steatite beads and bead manufacturing waste were also found from circular huts and constricted mouth storage pits. The hearths are lined with clay, whereas bricks were plastered with red ochre clay. Some mud brick walls having bricks in the ratio of 1:2:4 were also reported. According to the excavator, the standard Harappan brick size started from the 'early Ravi phase' giving a clear idea that before this area witnessed the growth of urban centre, a beginning was already made (for details see Kenoyer 2011)

The excavator of Harappa has assigned this phase of period 1A and 1B (Early Harappan/Ravi Phase), a time range between c. 3700 – 2800 BCE and period 2 (Early Harappan/Kot Diji Phase) between c. 2800-2600 BCE and termed as 'Regionalisation Era' (Kenoyer 2011). This period without any cultural gap was succeeded by Harappan phase (Period 3A-C-Period 4), Late Harappan (transitional) and Cemetery H (period 5) (Fig. 16).

JALILPUR

Jalilpur located about 72 kms south-west

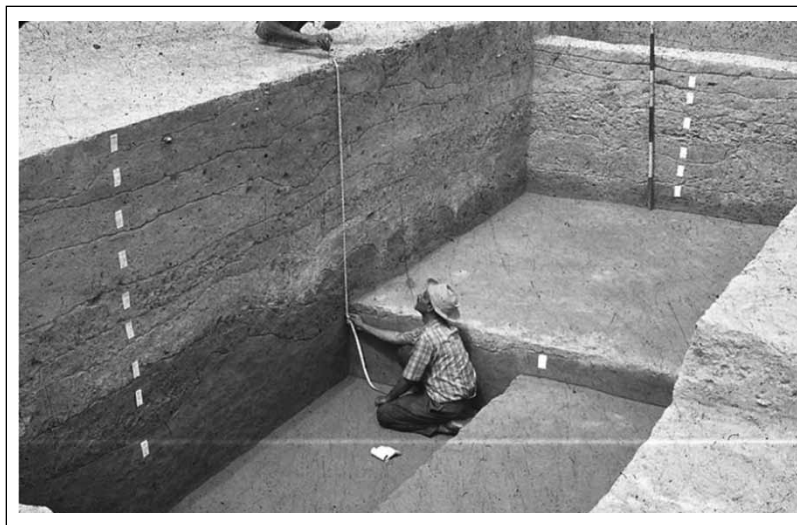

Fig. 17: Jalilpur: Hakra wares (Period- I) and Kot Dijian (Period-II,) (courtesy: M.R. Mughal)

of Harappa on the left bank of river Ravi in central Indus valley was excavated in 1972 by Mughal (Pakistan Archaeology no. 8, pp. 113-158). The material found from the site corresponds to pre-defence layers at Harappa, Kalibangan I and Kotdiji. The excavation revealed two cultural levels: period I just above the natural soil was devoid of any structure but the use of mud bricks and mud floor was attested. The pottery was handmade thick textured and tempered pieces of globular vessels with exterior surface coated with a mixture of clay and pottery bits (mud appliqué). Besides this other potteries namely plain red ware, red slipped and painted with black and brown or chocolate-on-red wares were also present (Figs 17 & 18; Plates 5 & 6). Other antiquities in this level included net sinkers, chert blades, bone points and burnt bones of animals. No copper was found. This pottery was also reported from Amri IA and from lowest levels at Sarai Khola. In period II



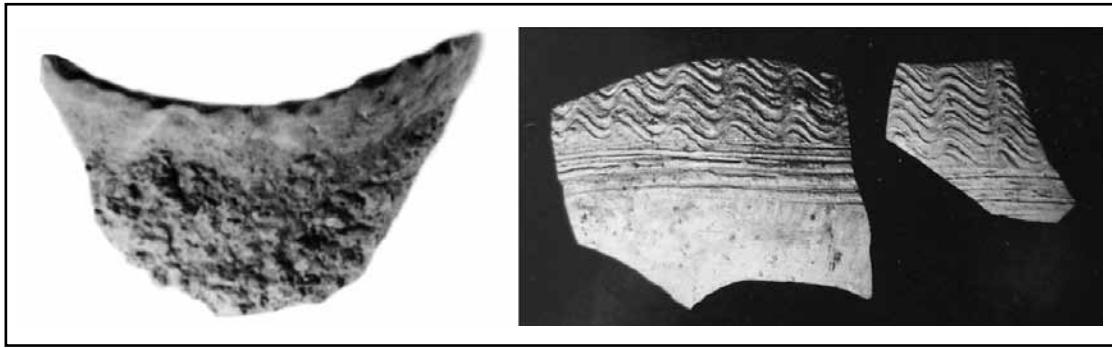

Fig. 18: Mud Appliqué and Multiple Incised lines of the Hakra Wares (courtesy: M.R. Mughal)

two structural phases one in IIA and other in IIB alongwith mud floors and pottery were noticed. The change in the cultural levels from period I to period II was gradual and there was no break. The above pottery continued with increased numbers and was predominantly wheel-made wares. The mature Harappa phase is absent from this site and it was re-occupied during medieval period.

A few other sites were also located to the north and south of Harappa along the Ravi river at Rajanpur broadly speaking having the same cultural material as noticed at Jalilpur.

GOMAL PLAIN

Dani was the first who carried out the survey of Gomal plain which is divided from Peshawar valley by a great hilly barrier, although the area was already explored earlier by Sir Alexander Cunningham and Aurel Stein. He discovered the sites of Hathala, Gumla and Rehman Dheri.

Hathala is a smaller site and revealed Kot Dijian pottery, bangles, stone tools and other grinding objects. The site is damaged by illegal digging and modern graves. The

area is littered with Kot Dijian material as at Jhandi Babar II and Maru I. Jhandi Babar I, adjacent to Jhandi Babar II is a Neolithic settlement in this area (Ali and Eltsov 2009). This is also a good area to find out the genesis of urban growth.

GUMLA

The excavations at Gumla revealed five periods. Period I yielded microliths, whereas, in period II some negligible handmade pottery was found. Period III was a temporary desertion, but new pottery tradition along with terracotta figurines, parallel sided blades were noticed. The pottery has the painting of a horned deity identical with the one at Kot Dijian (Plate 7). Period IV was destroyed by a fire, but, two distinct cultural sub-periods were noticed and that are assignable to the mature Harappan period. Period V is dotted with graves, horse bones and terracotta horse models whose exact dates could not be determined. Period VI belongs to Iron Age.

SARAI KHOLA

Sarai Khola is located on the north of Gomal plains right on the banks of Kala Nala

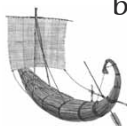

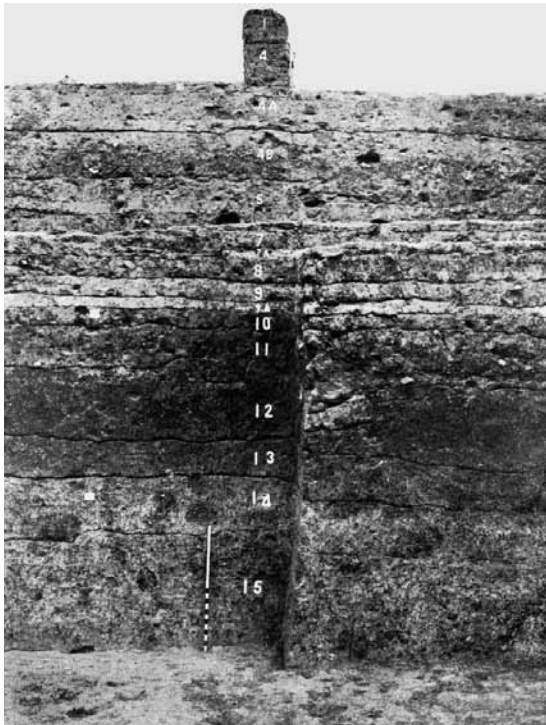

Fig. 19: Sarai Khola: Southern trench, northern section from layer (I) to the natural soil in (14)

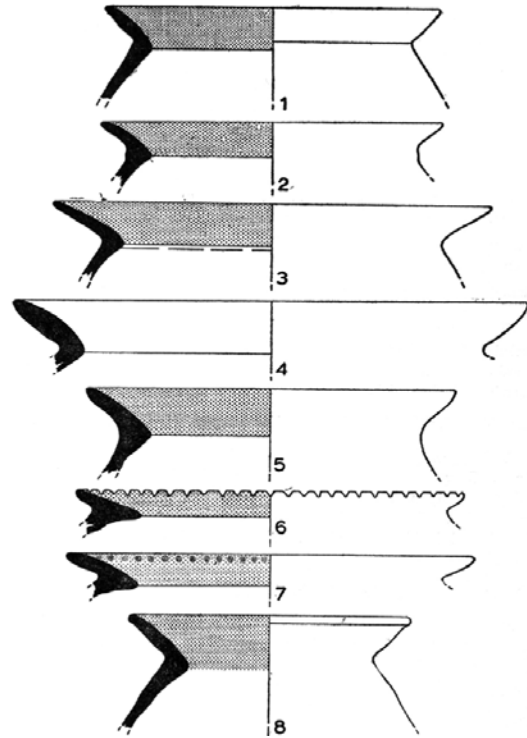

Fig. 20: Sarai Khola: Burnished vessels

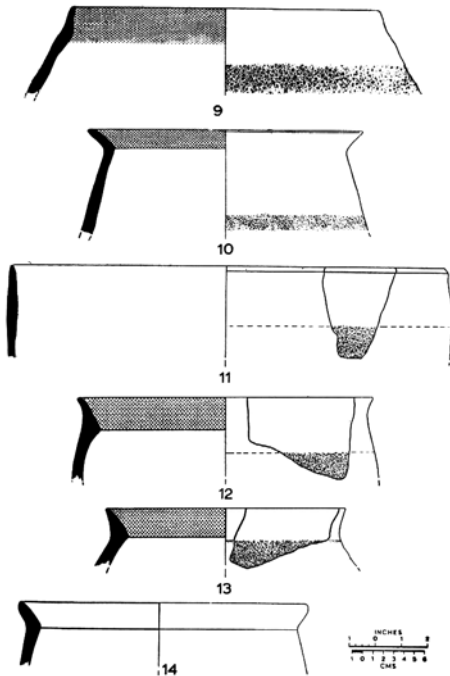

Fig. 21: Sarai Khola: Handmade ware with period-I (Type I) appliqué surface period-I (Type II)

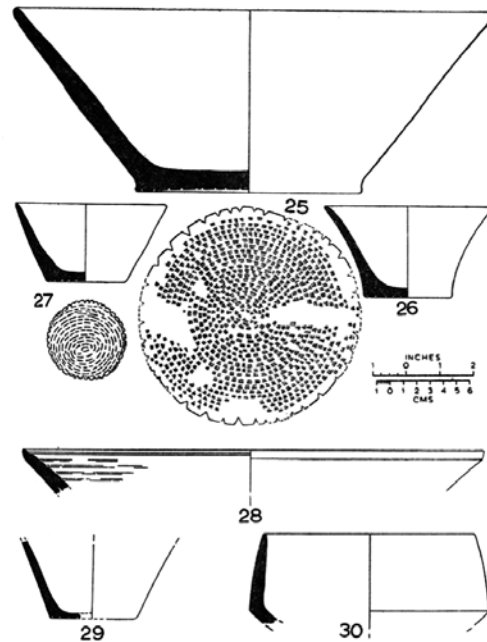

Fig. 22: Sarai Khola: Handmade burnished bowls with basket impression bases period-I (type IV and IVA)



bridge in the Potwar plateau adjoining Taxila valley. The site was excavated from 1968 until March 1971 by Muhammad Abdul Halim (1972 no. 8, pp 1-112, 1972, no. 7 (1970-71) pp. 23-89). It revealed in excavation, four periods (Fig. 19) starting from polished stone celts, chert blades and handmade red burnished pottery (Fig. 20), followed by Kot Dijian pottery in period-II (Fig. 21) which overlapped by red burnished ware in the early levels with stone structures and post holes in the upper levels of this period. The period-III which was occupied after a long desertion with the discovery of a regular cemetery revealed having two phases designated as early and late but belonging to the users of iron. The red burnished ware and bowls from period-I resemble Kile Gul Mohammad wares and have been dated around 3100-3000 BCE. Certain potsherds from period-I (Sarai Khola pottery type II) having thick coat mixed with mud applied on the exterior surface on which sand was dusted (generally called mud appliqué ware) have also been reported from Amri level 1A, Jalilpur and also from Hakra/Sarasvati valley (Fig. 22). This ware is different from granulated wares of Anjira. From this level basket impression occurring on the bases of the ware have also been found having resemblance with the similar pottery of Burzahom in Kashmir and Yangshao horizon in north China belonging to neolithic period.

Dam-Saddat, another site located about 16 km south of Kile Gul Mohammad is bigger and richer in comparison to above site. Other

sites excavated in Quetta valley include Karez, Kechi Beg, Mughal Ghundai, Periano Ghundai and others whose stratigraphical position has to be ascertained by new excavations before any final verdict can be given.

REHMAN DHERI

Rehman Dheri in Gomal plain was discovered by Dani (1970-71). It was excavated by FA Durrani (1988, Ancient Pakistan Vol. 6, pp.1-147) who struck in excavation one of the first well planned fortified city belonging to the late 4th - 3rd millennium BCE and also one of the most important regional centres of Harappan civilisation. In exploration, a microlithic industry was also found from the surface, whereas, in regular excavations the following periods were noticed.

Period IA which has been assigned between 3400-3300 BCE contained structure of packed mud shaped clay slabs and dressed clay blocks. It revealed main city wall and also two house units consisting of a number of rooms. In one of the rooms, a circular grain silo was noticed. Other objects include the earliest seal, unique fish bowls and other finds. In another rooms, even a larger silo was noticed which was found filled up with the fallen roof and charred grains.

The pottery was made on fast wheel, although a few handmade vessels were also noticed. The red and buff ware pottery was having painted designs namely geometrical, floral and zoomorphic motifs. One jar was even painted with the *pipal* leaf. In the category of plant remains, grain seeds were



found stored in private grain silos along with stone grinders. Among the faunal remains, buffalo, cattle, sheep, goat and fish bones were recovered.

Period IB (3100-2850 BCE), the enclosure wall of the city was found continuing on the south side. In ceramics, the carinated bowl dominated and in painting, motifs increased in diversity and complexity. The 'Rehman Dheri fish' motifs increased in number and variety (Plate 8). The excavator reported the presence of swastika and Kot Diji-Sothi ceramics for the first time. The pottery of IA continued. A unique ivory seal was also noticed.

Period II (2850-2500 BCE) has witnessed platform building and the levelling of all the earlier layers. The continuation of earlier period showed no change. Open rectangular hearths and circular ovens were noticed. Large storage jars were used for storing grains. The Kot Dijian type jars and Kot Diji-Sothi type continues more frequently. The earlier plant and faunal remains continued.

Period IIIA & B (2500-1900 BCE) witnessed major platform building and levelling of layers. The earlier pottery decreased and evolved Kot Dijian types comparable to with typical Harappan examples and painted motifs occur in great number. Wheat and barley fragments were found along with the continuity of earlier faunal remains.

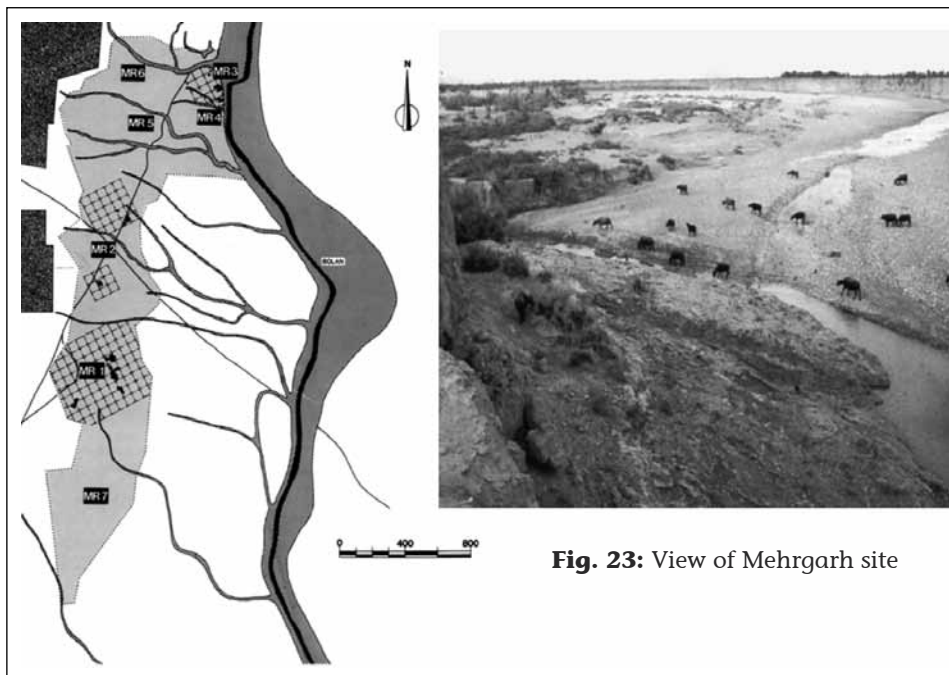

Fig. 23: View of Mehrgarh site

MEHRGARH

The excavations at Mehrgarh in Baluchistan (Fig. 23) at the foot of the Bolan Pass during 1974-1985 by the French Archaeological Mission to Pakistan and Department of Archaeology of Pakistan have revealed continuous cultural development since the 7th millennium BCE (Jarrige *et al.* 1995) (Figs. 24 & 25). The period I was earlier divided in phase IA and IB; IA was aceramic followed by period IB when the first coarse chaff tempered ceramic appeared and then in period IIA the same ceramic continued. Some structures assigned to period IB actually start from period IIA.

Recently the period IA and IB have been simply called as aceramic and renamed as period I. The aceramic was about 7 m thick and divided into 9 main levels. Burial activities were also noticed. A four-room



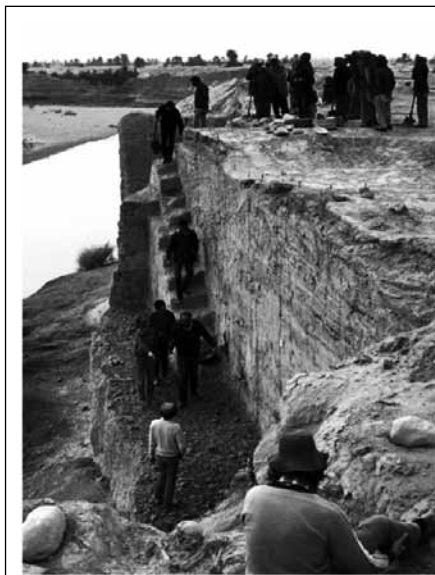

Mehrgarh, ten meters of mound build up - 6500-5500 BC

Houses from the end of the pre-pottery neolithic - circa 5500 BC (Courtesy: M. Kenoyer)

Fig. 24

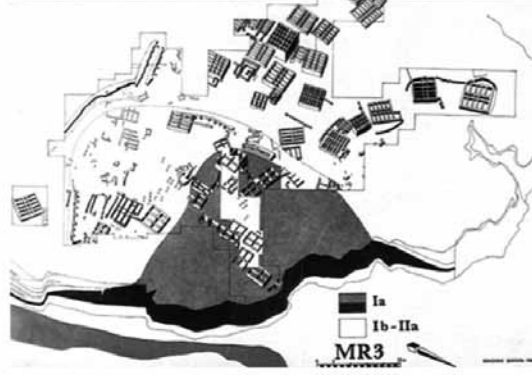

Fig. 25

building was used by the inhabitants of period I. From all the levels structures were reported along with fire places in many rooms. Circular fire pits were also found.

There is also an evolution of the lithic industry from period I to period IIA. From this period flint microliths set in bitumen were also noticed. While in these nine levels, every level has revealed a graveyard which has yielded grave goods (Figs. 26, 27 & 28).

In period IIA, around 6000 BCE crude potsherds with heavy shaft temper were found in a limited quantity. The types are mostly bowls and vessels. The circular houses of the Neolithic villagers have not been found at Mehrgarh. The major contribution of Mehrgarh going back as early as the 8th millennium BCE in the north-western regions of Pakistan is the biggest discovery

of the region.

In the successive period II, this kind of development or evolution also occurred in the Zagros Mountain with more evolved pottery and transformation of agricultural economy. The commonality of certain traits such as crude pottery, similar human figurines and some groups of butt-racing walls made of bricks with finger impressions connect the arrival of population from Iran to Baluchistan during the 6th millennium BCE.

However to establish the Neolithic of Mehrgarh between other regions of Baluchistan and Indus drainage system require further research as the case in the Bolan basin.

The transitional link phase between period IIB and period IIIA is a problem to



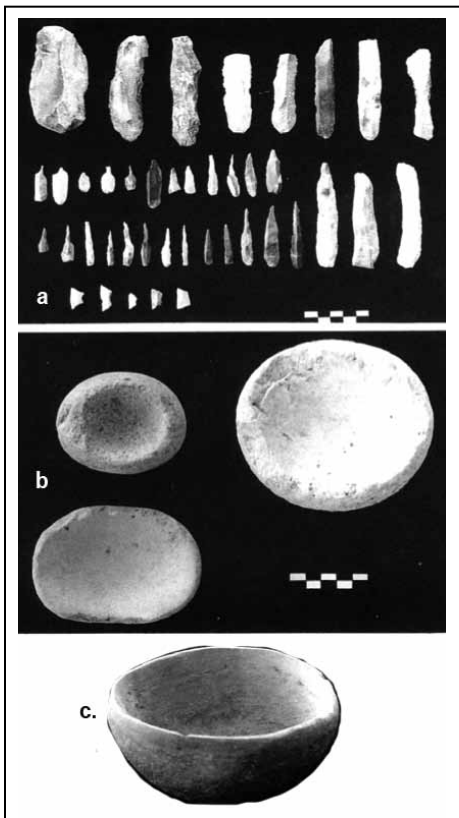

Fig. 26: Mehrgarh: Area MR 3/4, period IIA,
 a. chipped stone assemblage,
 b. Stone mortars,
 c. Stone vessel

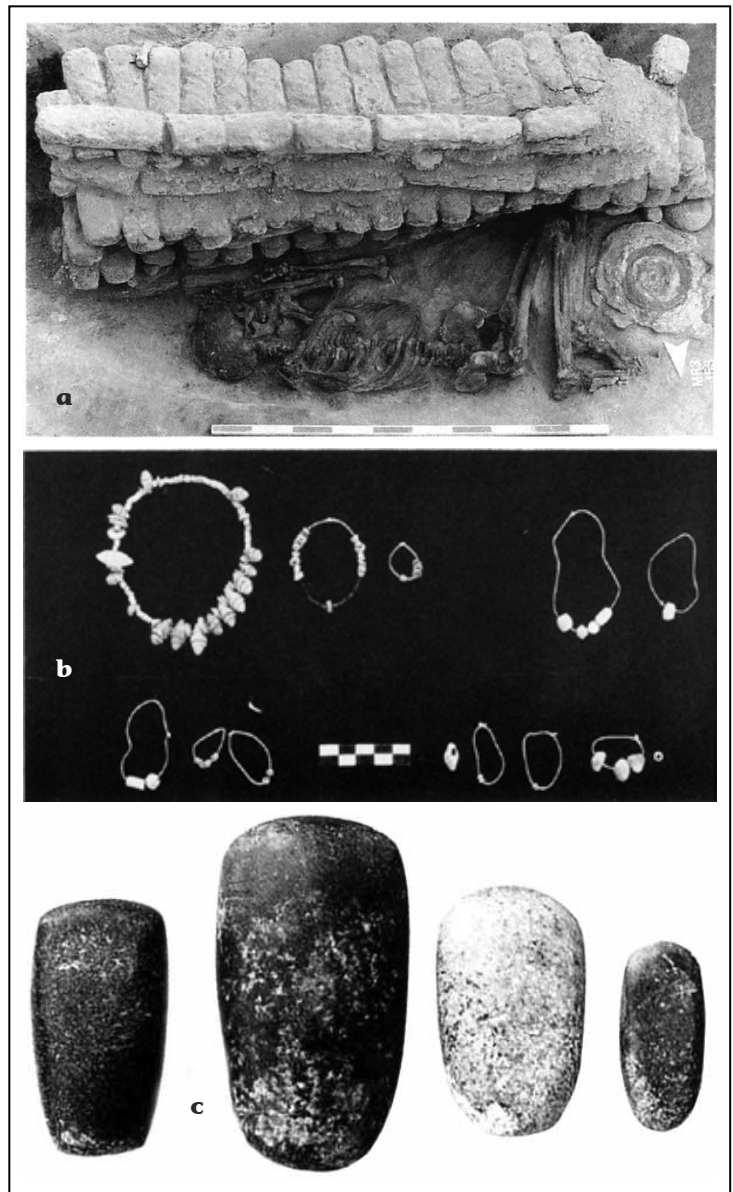
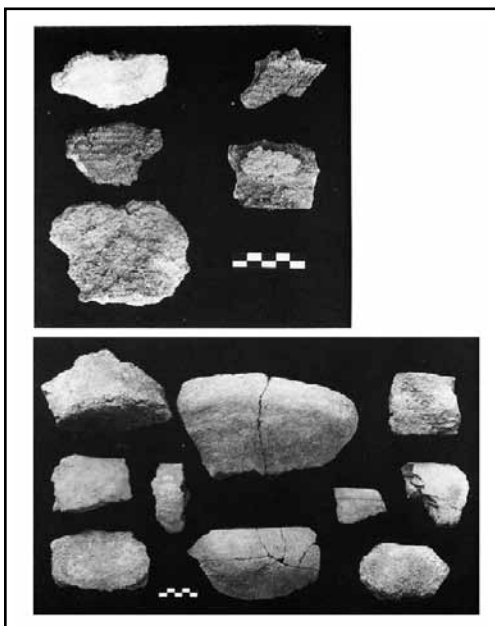

Fig. 28: Mehrgarh: Area MR 3/3, grave and grave goods from period IB.
 a. Grave 153
 b. Shell and stone ornaments from graves 152, 153, 154 and 159
 c. Polished stone axes from graves 153, 152 and 103B

Fig. 27: Mehrgarh: Area MR 3/4, period IIA.
 a. Coarse ware sherds with basket impression
 b. Coarse chaff tempered sherds





Fig. 29: Mehrgarh: Terracotta figurines from Fourth period (period VII, courtesy: Jarrige)

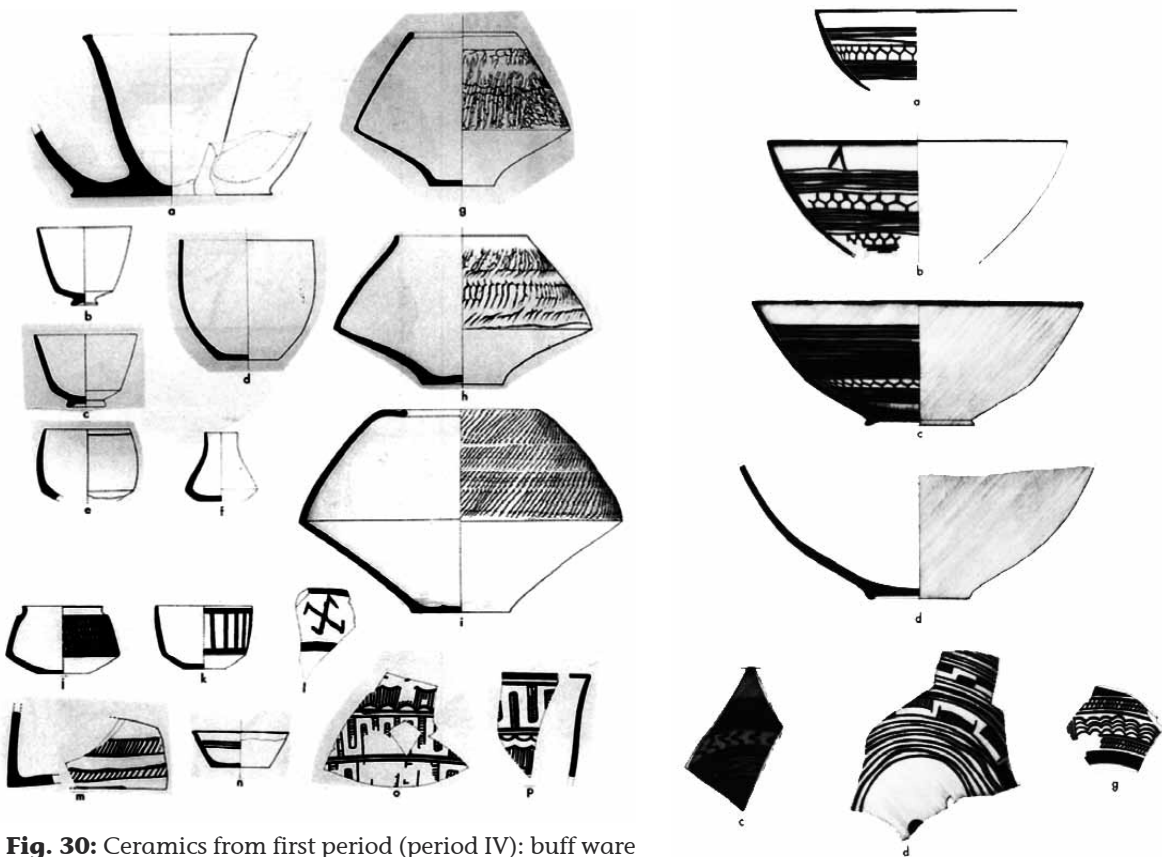

Fig. 30: Ceramics from first period (period IV): buff ware (a to f)

Fig. 31: Red painted bowls with a dark brown design in Togau wet ware (f to i) and painted buff ware (i to p) style from first period (period IV)



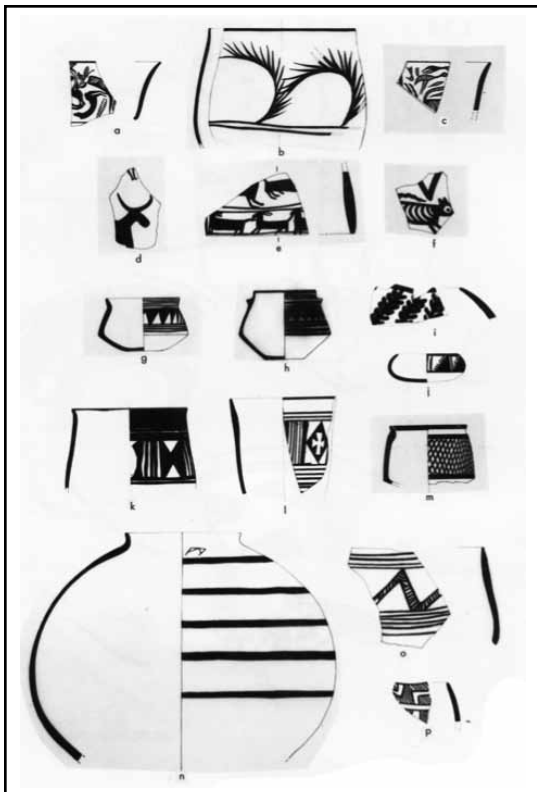

Fig. 32: Mehrgarh : Ceramics from third period

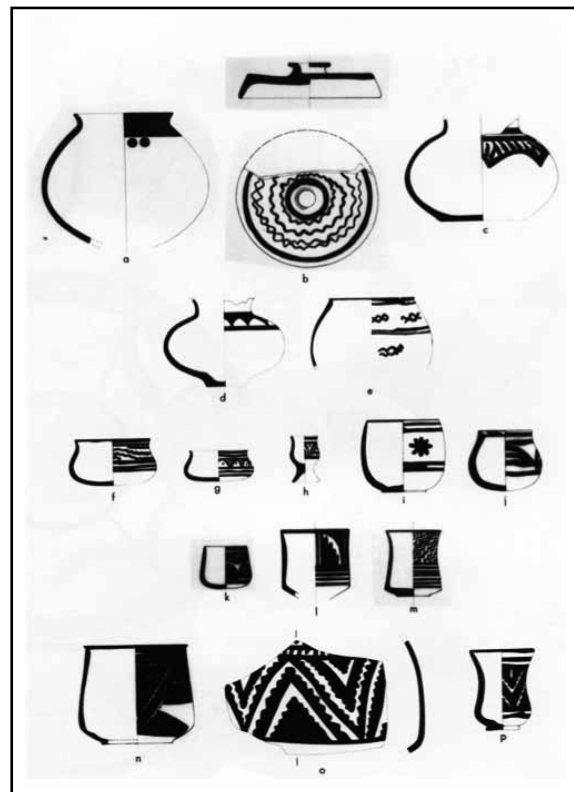

Fig. 33: Mehrgarh: Ceramics from Fourth Period (period VI) brown on buff (period VII): Buff painted (courtesy: Jarrige)

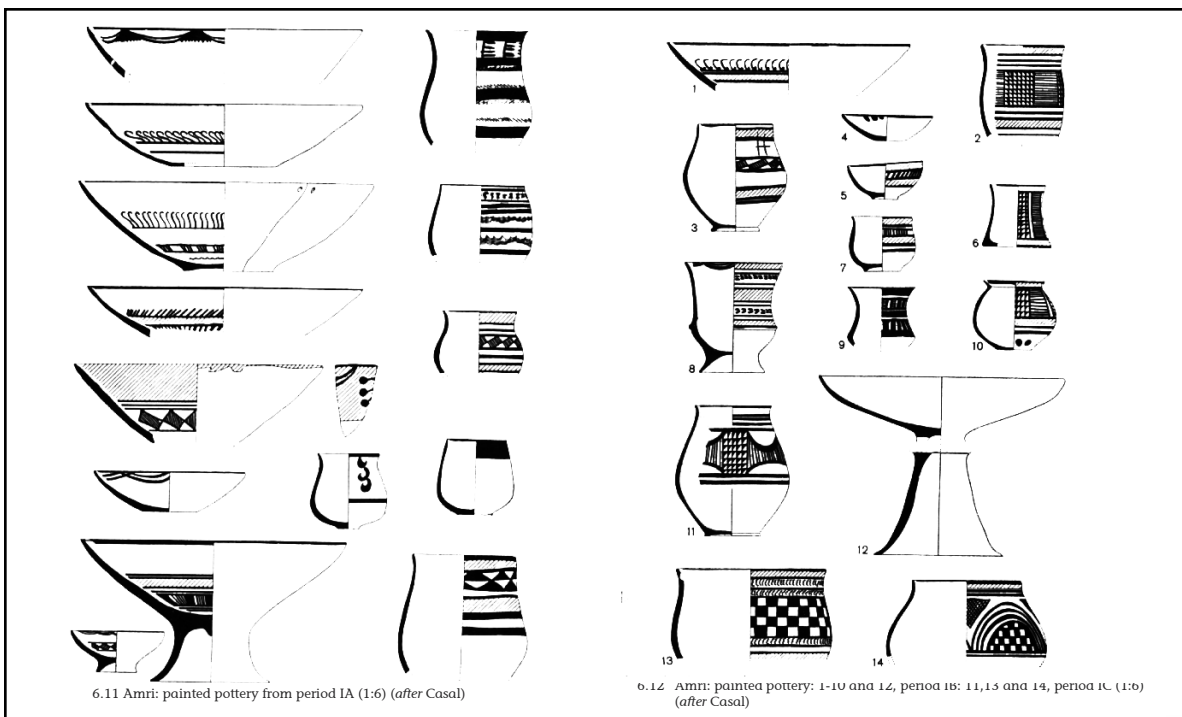

Fig. 34: Amri: painted pottery



decoration combined with caprids and birds. It is associated with artifacts like flint, grindstones, circular stones with holes etc. the agricultural economy including animal husbandry dominated as in the early Neolithic period.

The next occupants between 3500-2500 BCE belong to the beginning of Mohenjodaro to Harappan occupation at Amri IIIA. The pottery makers from the earlier periods IA and IB appear to be the descendents of Mehrgarh while they came down from the hilly tracts. Mehrgarh is a good example showing a continuous development from the end of 8th millennium BCE to the middle of 3rd millennium BCE (period IV) (Figs. 29 – 34).

The radio-carbon dates from Mehrgarh of period IA, the earliest goes to 7435 BCE whereas in period IB the date is 6490 BCE. In period IIA the earliest date is 4653 BCE, from period IIB 6090 BCE and from period III, the date is 5489 BCE. However, a deduction can be arrived that this site was in continuous occupation right from the middle of the 8th millennium BCE to the middle of 3rd millennium BCE including period IV (Jarrige *et al.* 1995: 555-556). (Table 1)

THAR DESERT

The eastern side of Sindh is a part of Thar desert where once the Hakra river flowed through the eastern side along the fringes of this area. The present work done by Qasid H. Mallah (Mallah, 2008, 27-76) revealed sites of different periods starting from Hakra /Ravi, Amri to Kot Diji to the late Indus period. This data of lower Indus is very

important as it holds the roots of successive complexes fulfilling the preconditions of urbanization. These sites are 75 in numbers but have not been excavated yet as is the case in the Cholistan area (Plate 9). This area adjoins the part of north Gujarat which has clearly established the presence of the early Harappan communities directly affiliated to the coastal area of Sindh and Baluchistan stretching from Karachi to the coastal region of Rann of Kachchh. The region beyond Thatta is generally delta area. During the period of inundation it is flooded about 32 kms inside. It is important for good subsistence including source of shell and fish and in exploration many archaeological settlements were found in this area.

KOT DIJI

Located on the national highway, 25 km south of Khairpur town, Kot Diji is also having a medieval fort built on a rock on its south (Fig. 35). The site was excavated in 1955 which accidentally revealed a pre-Harappan stage now called Early Harappa succeeded by mature Harappans represented by their town planning and other material culture. The occupational deposit at Kot Diji was about 7.50 m. From layer (1) to layer (3) was mature Harappan ware as from layer (3A) upto (16), a different pottery along with a pre-Harappan fortified citadel was encountered (Fig. 36). This change in pottery from 'thick to a thin type of pottery' is a completely new ceramic not encountered before (Figs. 37 – 46). It has no conformity in texture, form or paintings/incised designs



Table 1: Radiometric dates from Mehrgarh (Jarrige *et al.* 1995)

Sub-Period	Lab. No.	Dates in BP	Calibrated BCE (One sigma range)
I A	BETA-1408	6925 ± 80	5953 (5749) 5660
I A	BETA-1407	7115± 290	6219 (5980) 5650
I A	LY-1948	5720±730	5380 (4653,4648,4581) 3780
I A	LY-1949	5530±180	4577 (4360) 4167
IA	LY-1947	5830±190	4937 (4725) 4470
IA	BETA-1721	9385±120	n.a. 7435 BCE
IB	LV-993	6110±90	5217 (5190,5058) 4906
IB	LV-994	6290±70	5326 (5238) 5219
IB	Ly. 1950	8440±250	n.a. 6490 BCE (rerun)
IB	LY-908	6090±70	5203 (5046, 5019, 5004) 4906
IB	LV-909	5940±100	4940 (4892,4887,4841) 4727
IB	LV-910	5880±100	4900 (4782)4680
IIA	BETA-7315	5620 ± 100	4653 (4465) 4360
IIA	BETA- 2688	5490 ± 70	4459 (4350) 4240
IIA	BETA-7314	5400 ± 90	4351 (4318, 4285, 4246) 4049
IIB	BETA-1720	7115 ± 120	6090 (5980) 5830
IIB	BETA- 2687	5240 ± 110	4233 (4037, 4014, 4008) 3970
IIB	Ly. 1945	5360 ± 310	4510 (4235) 3816
III	BETA-2689	6500 ± 80	5489 (5474, 5435, 5426) 5342

with the mature Harappa and also different in features which is dominated by fine thin body, short beaded or slightly averted rim having a broad generally black band around the neck. The dish on stand is common in the late levels. It also includes minor antiquities of stone namely fine micro-blades (Figs. 47-

48), sharp and thin long knife blades and also terracotta objects such as toys, painted bangles, cakes, cones and beads. Bronze objects are present but are few in numbers. It has regular stone walls and mud-brick walls with regular mud floors. This pottery could be also associated with Amri ware and pre-



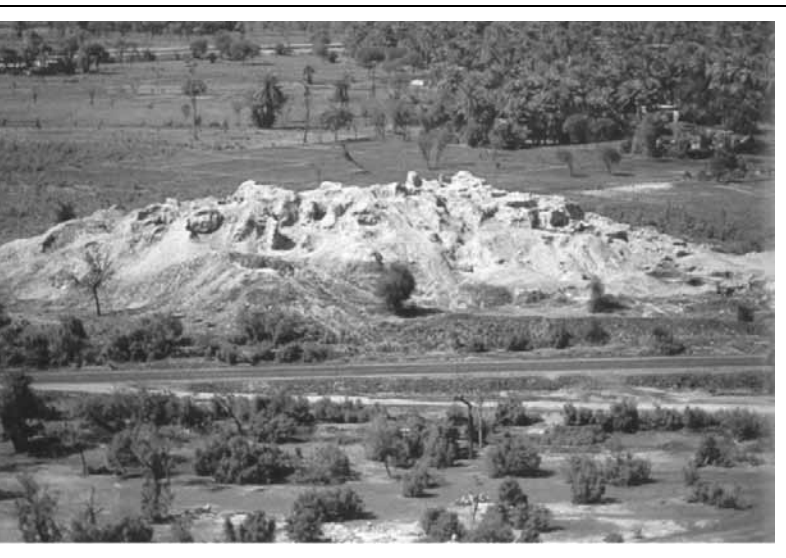

Fig. 35: Kot Diji mound on the Indus river

defence pottery at Harappa.

While examining the published pottery of Kot Diji, no mud appliqué sherd was found which is a hallmark of Hakra ware collection including Harappa and Jalilpur. In Saraswati complex in India, an incised decorated pottery was also found accompanying the mud appliqué pottery in the lowest levels especially at Bhirrana.

CHOLISTAN

Mughal explored Cholistan area in Bahawalpur state between 1974 and 1977 and noticed about 377 protohistoric sites and classified the surface collection as per different categories of settlements viz. camp sites, industrial and multi-functional sites revealing their craft related activities (Mughal 1997: 1-170; 1990: 1-72). Out of these explored sites, 99 were marked representing the earlier period called Hakra (river Sarasvati is known as Hakra in this

area) (Fig. 49). Mughal has pointed out that now this area consists of wide open muddy land covered with drift sand that has advanced 30-35 km eastward adjoining Thar desert. In order to connect Hakra-Sarasvati at one end with Jalilpur and Harappa on the other, the excavations at Ganweriwala near Derawar Fort or some other suitable site in Cholistan area of Bahawalpur State which is lying in between needs to be studied in depth, so that Hakra ware settlement pattern could be placed in a wider context.

The Hakra wares are quite distinctive by the shape technique of manufacture, fabric and surface treatment. Mughal has

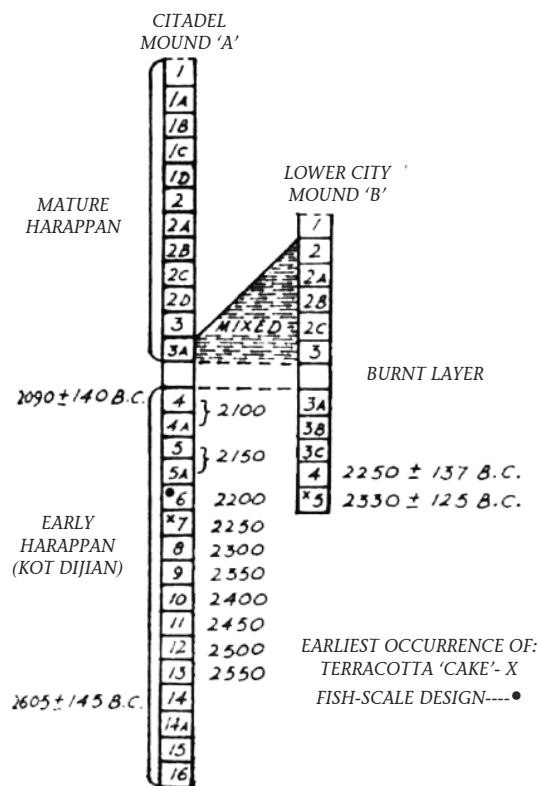

Schematic correlation of stratigraphic Sequences at Kot Diji (After Mughal)

Fig. 36





Fig. 37: Kot Diji Culture: Jar painted



Fig. 38: Kot Diji level: Water pitcher with fish scale patterns painted with a horned deity

found that the area between Fort Abbas and Khanpur constitutes an area of cultural unity. The pottery types include incised, mud appliqué, wide shouldered black slipped ware, black painted pottery, painted buff pottery, plain saucer shaped lids, grey pottery, pedestal pottery and wheelmade and handmade bowls with splayed out rims usually devoid of any decoration, carinated cups and plain dishes with red slip with a thick splayed out rims which is not a frequent occurrence. The mud appliqué and



Fig. 39: Kot Diji culture: Painted pottery

incised wares have not continued on Early Harappan sites namely Kot Diji I and Jalilpur II (Figs. 50 – 53 & 56).

The Hakra ware sites also yielded the material of Early Harappan period in exploration similar to Kot Dijian pottery and also associated materials of that period. This Early Harappan pottery has also been reported from Kalibangan I, Banawali I, Balu I and many other sites in Sarasvati region (Figs. 54, 55, 57).

The lithic tools associated with the Hakra wares largely consists of micro-liths perhaps survivals from the neolithic tradition of Indus valley. Objects like stone mullers, beads of lapis lazuli and terracotta, shell objects



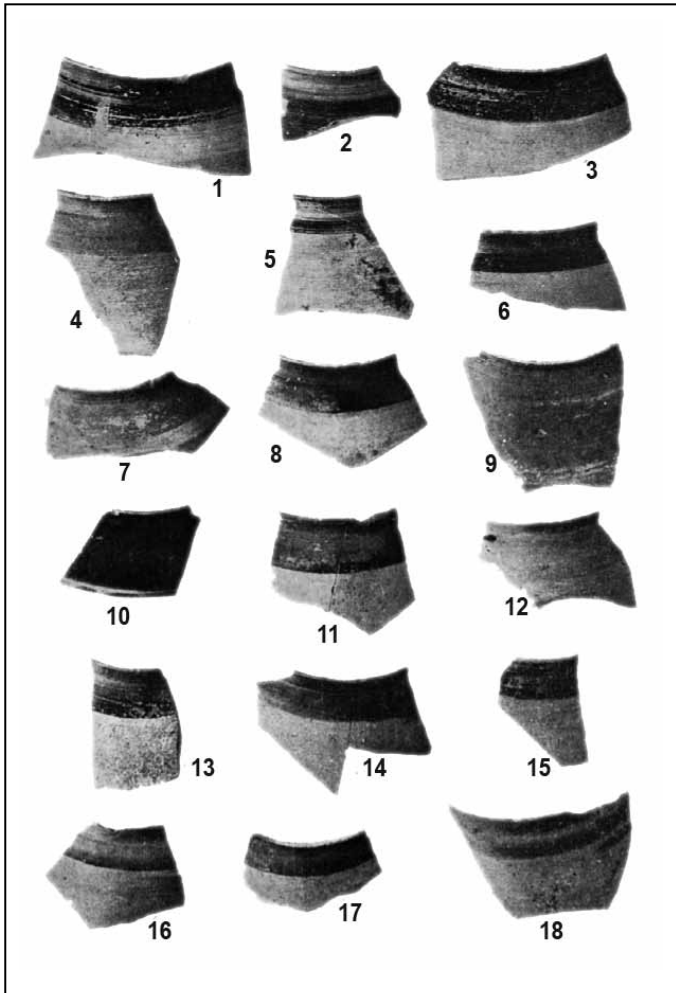

Fig. 40: Kot Diji culture: Bowls and dishes with broad neck bands in dark red, brown or sepia

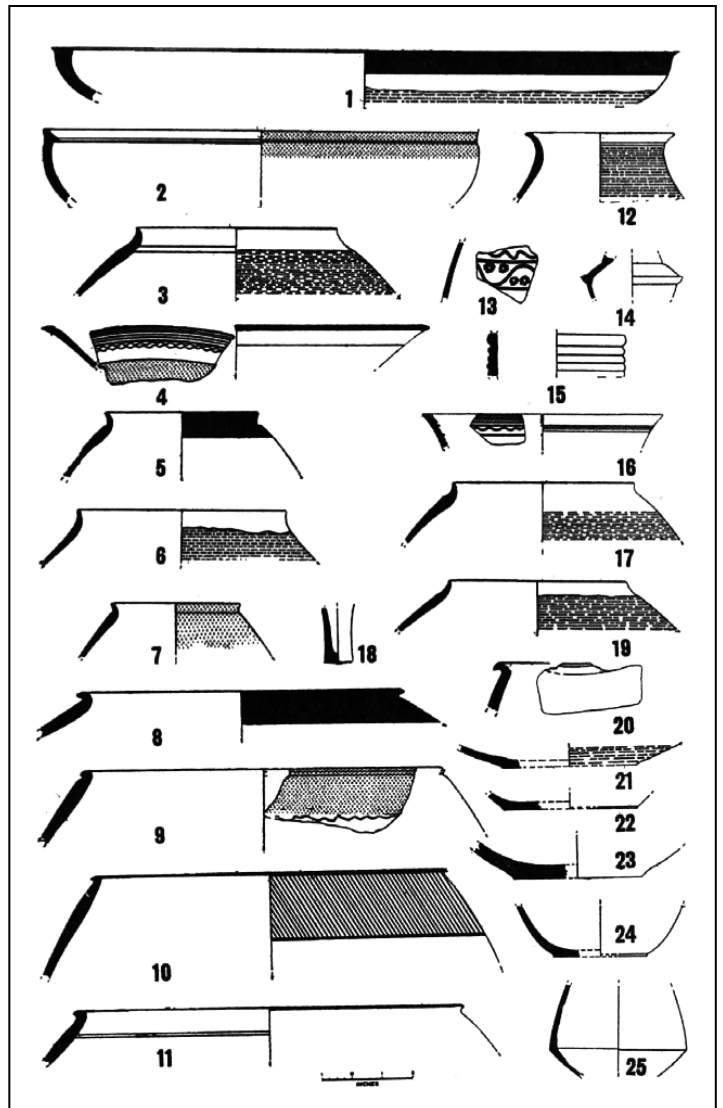

Fig. 41: Pottery from square BIV/6



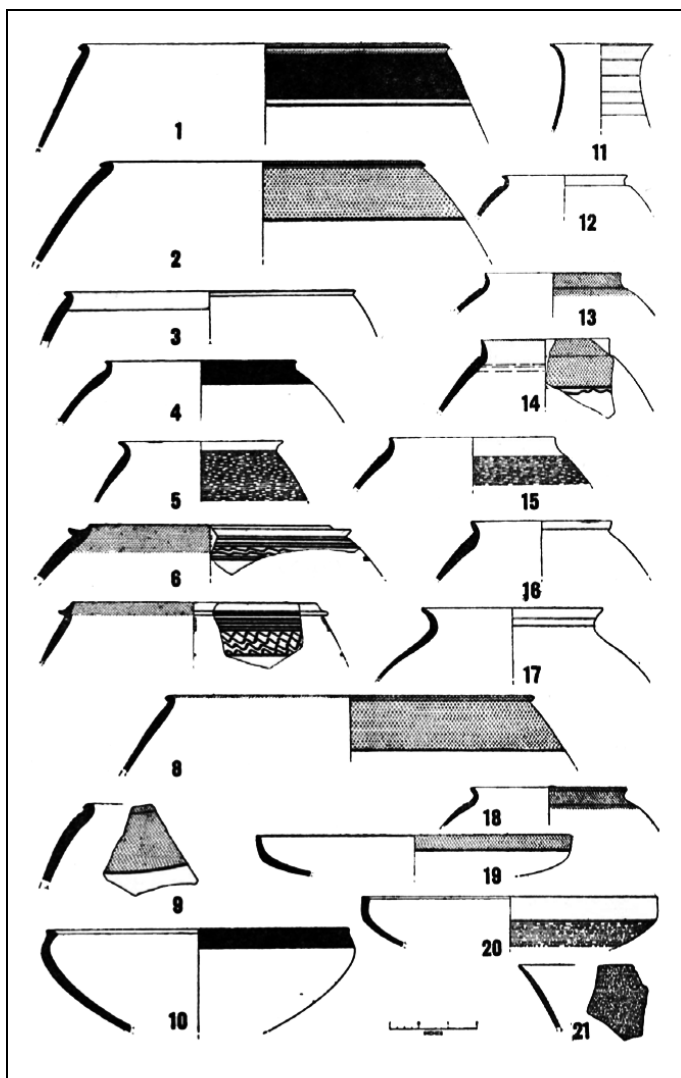

Fig. 43: Pottery from square BIV/6 layer (11)-(12)

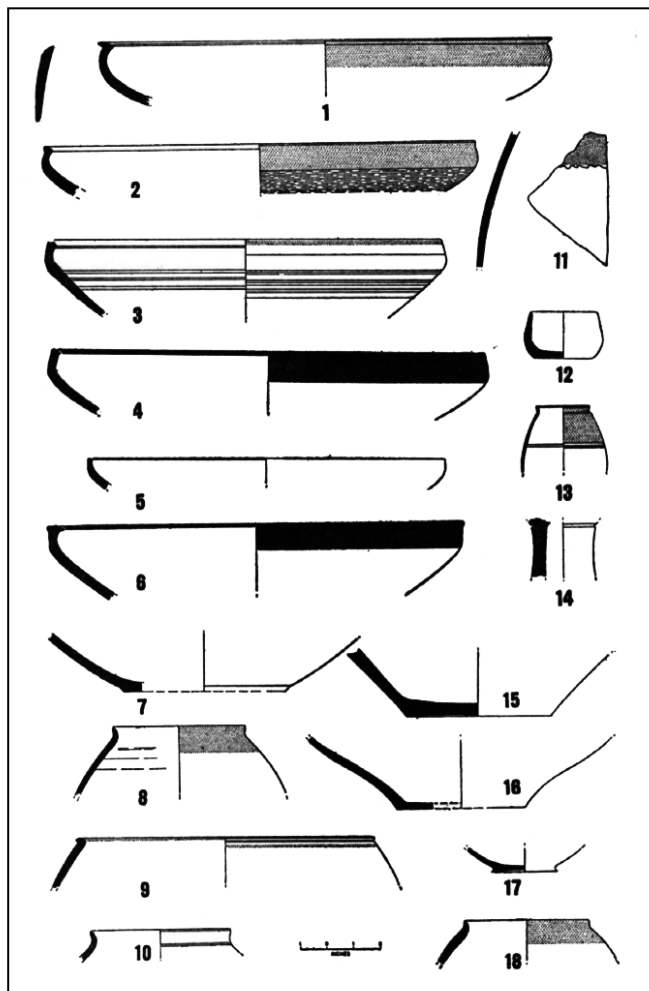

Fig. 42: Pottery from square BIV/6 layer (14A)-(16) layer (12)-(14A)



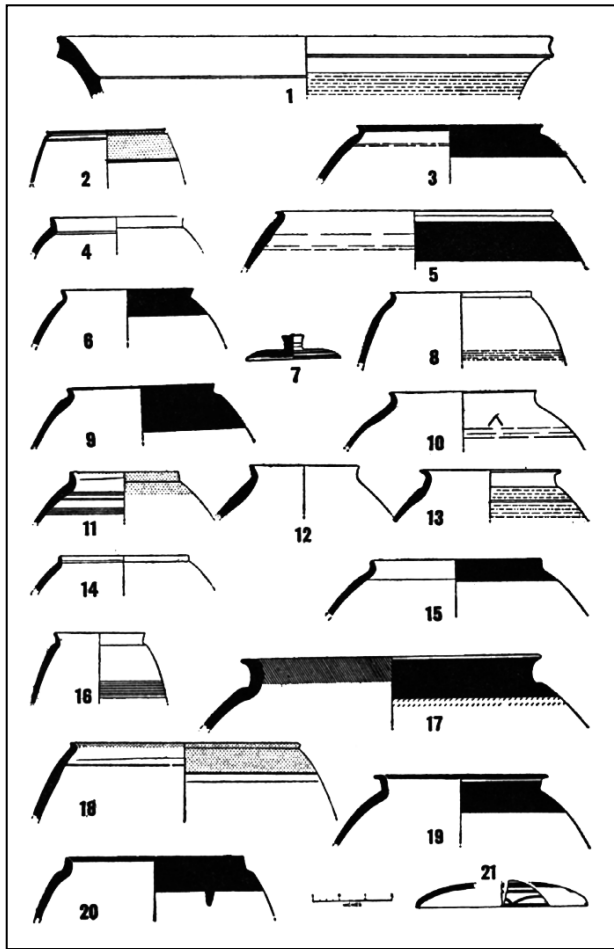

Fig. 44: Pottery from square BIV/6 layer (7)-(8)

were found along with the material of Early Harappans (Figs. 58-59).

ANALYSIS OF EVIDENCE FROM PAKISTAN

To understand the beginning of civilisation in the Indo-Pak subcontinent, watered by the Indus system of rivers, the different cultural stages, especially during 7th-5th millennium BCE has to be defined. How did the Mesolithic people survive through the beginning of Neolithic to the ascendancy of Chalcolithic and ultimately to full urbanisation?. The

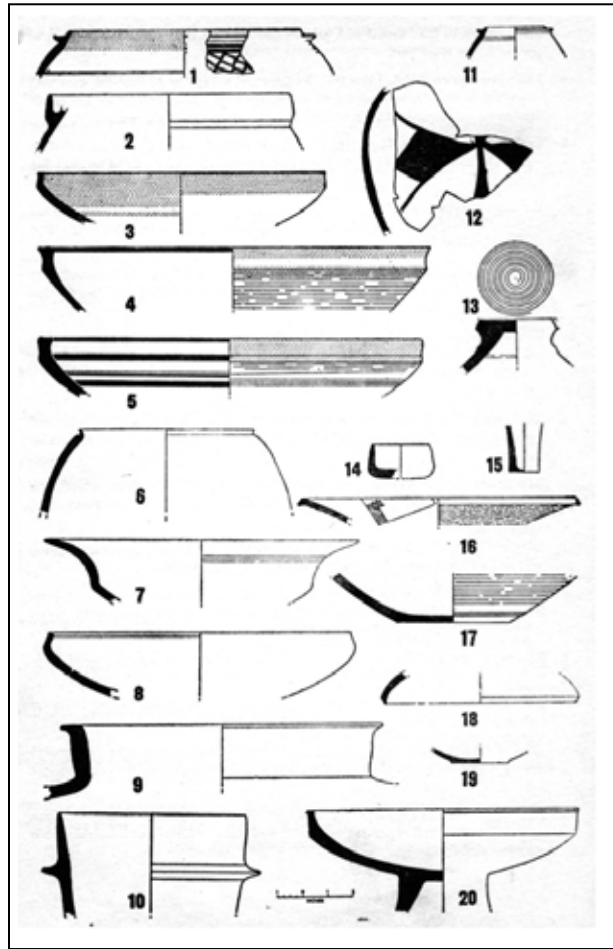

Fig. 45: Pottery from square BIV/6 layer (6)-(7)

phase of pre-early Harappan cultures, an early food producing stage is identified by a complex present at Mehrgarh through period I to period III and has been assigned a time bracket supported by carbon 14 dates ranging between 6500-4500 BCE.

In Bannu and Gomal plains, right at the foot of Takht-i-Sulaiman, the cultural life in no way was different as the food gatherers were found using a multiple variety of lithic equipment which were also used profitably before the knowledge of agriculture became very common. These nomadic people also



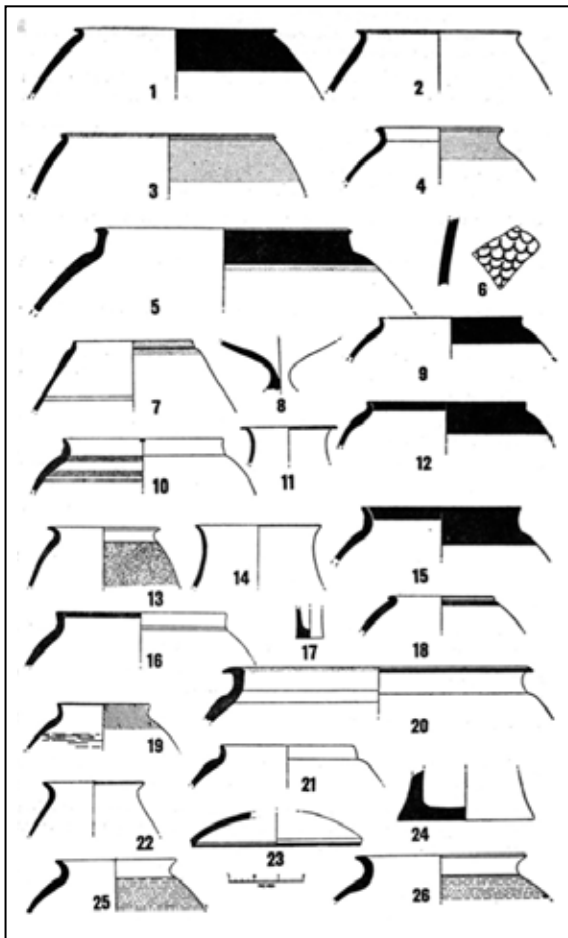

Fig. 46: Pottery from square BIV/6 layer (5A)-(6)

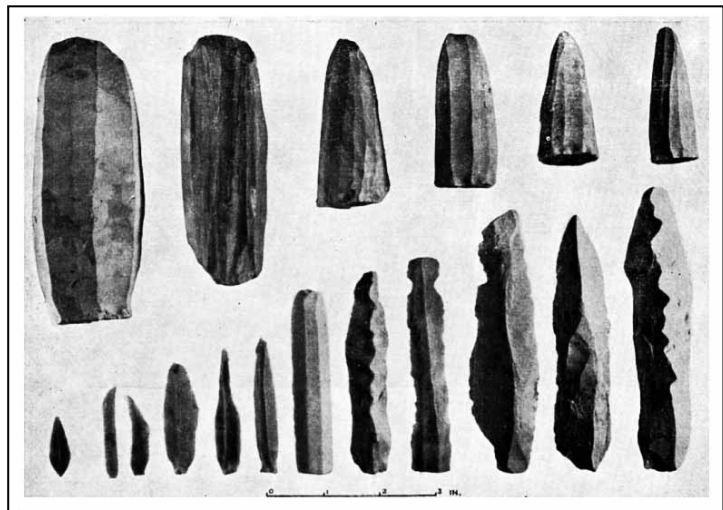

Fig. 47: Chert blades and cores: Harappa culture

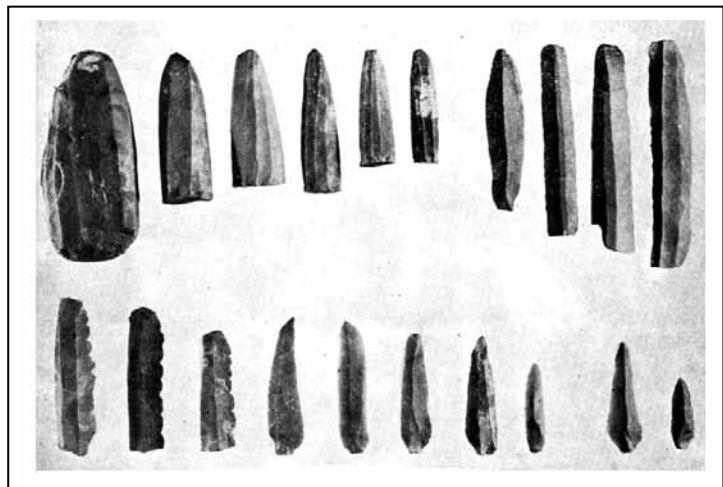

Fig. 48: Chert blades and cores: Kot Diji culture

appeared to have a longer duration of life because of climatic factors.

The excavations at Mehrgarh, Rehman Dheri, Gumla and Sarai Khola revealed the same process of development, which was common to all. In the next succeeding phase all the sites belonging from pre to early Harappan phases like Hakra, Ravi, Amri, Kot Diji, Nal etc. are clubbed in the absence of more datable data between c. 5500 to 2600 BCE (Kenoyer 2011).

DATA FROM INDIA

The sites belonging to Early Bronze Age Cultures which mainly include Harappan Civilization in Indo-Pak sub-continent ranging in time-bracket between c. 3500 BCE-1900 BCE, so far discovered are around 3000. They have been described as Harappan/Indus civilization/Indus-Sarasvati and Indus Age. In the last five decades the concentration of Harappan sites was noticed



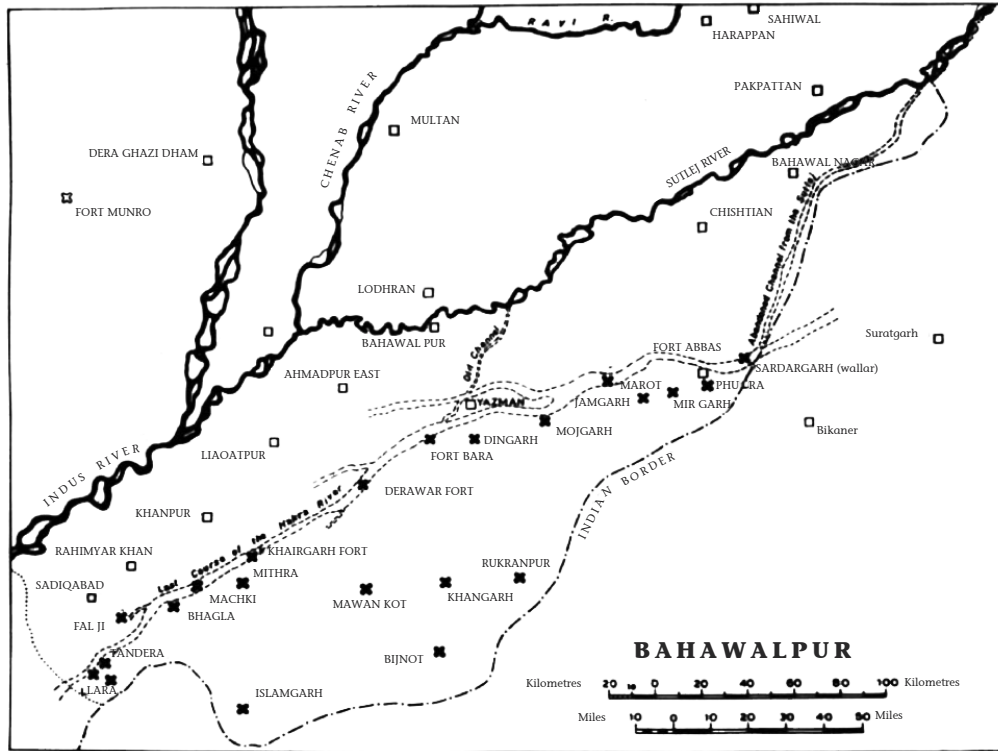

Fig. 49: Hakra/Sarasvati and its probable channels including river Sutlej passing through Bahawalpur

on the extinct Hakra-Sarasvati-Ghaggar and its equally extinct tributaries. The combined Sarasvati-Ghaggar rivers were perennial in northern Rajasthan during the Early Harappan and Harappan times. There is also evidence of the Painted Grey Ware sites but they are in a narrow bed suggesting that the river was getting less supply of water. In a further narrow bed, Rangmahal mounds were noticed. This phenomenon clearly indicates that the river was drying up.

Tessitori (1917-18: 22-23) and Aurel Stein (1942) found protohistoric settlements from Hanumangarh upto Bahawalpur in Pakistan. Further exploration and excavation by A. Ghosh revealed a sequence of three cultural phases, viz. Harappan, the Painted

Grey Ware and the Kushan. (Ghosh 1952: No.1) B.B. Lal and B.K. Thapar excavated Kalibangan and noticed remains of a fortified Early Harappan settlement, whereas Katy Frenchman made a trial dig at Binjor, west of Anupgarh on Pakistan border and surveyed the archaeological sites along the 'Lost' Sarasvati river. In 1978 the author revisited the archaeological sites explored by A. Ghosh and provided a chronological order in terms of regional dynamics including time bracket and nomenclature in relation to work done in India and Pakistan. Some trenches were also laid at Nohar and Sothi clearly defining early horizons (Dikshit 1984: 531-37). Excavations were also carried out at Baror and Tarkhanwala Dera by the



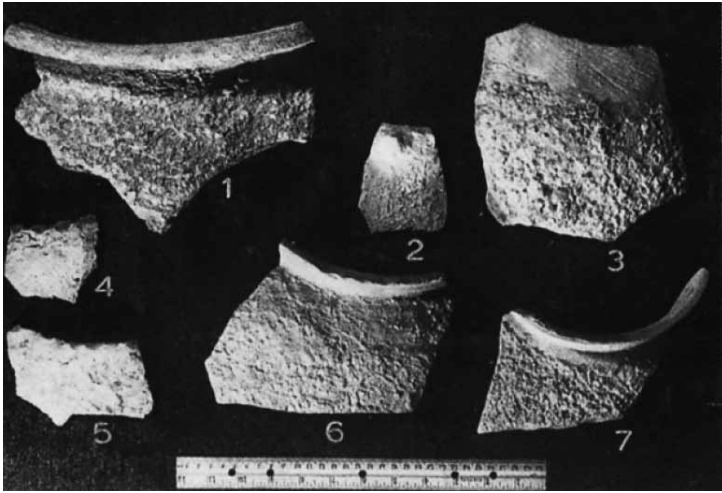

Fig. 50: Hakra appliqué pottery from Kalepar

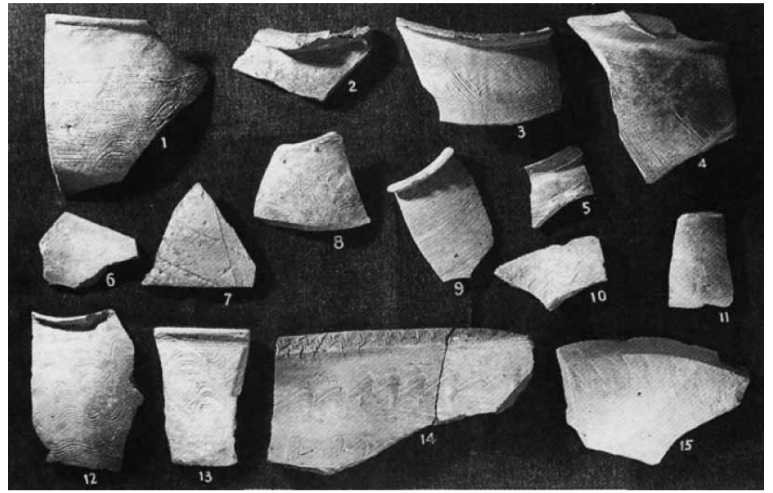

Fig. 51: Hakra incised pottery

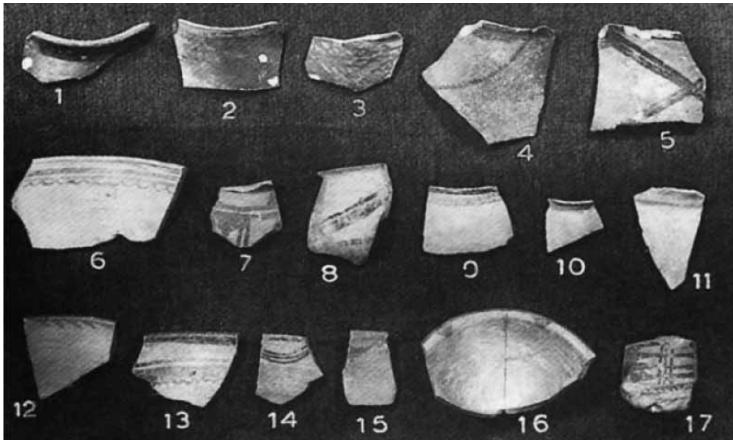

Fig. 52: Black burnished painted Hakra ware

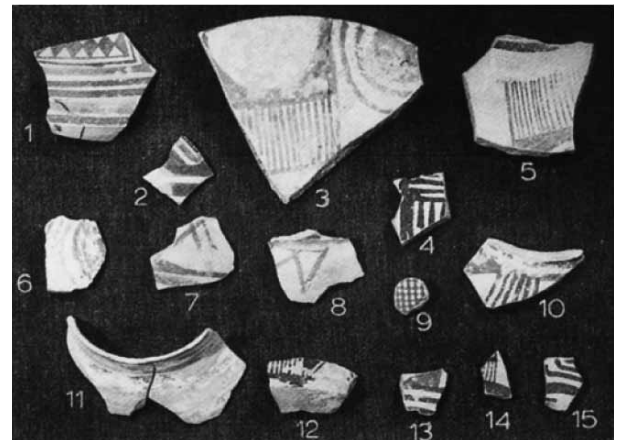

Fig. 53: Buff painted Hakra ware

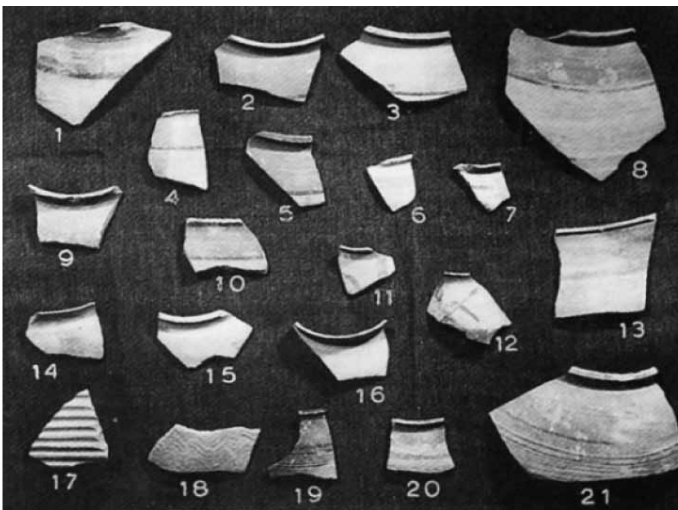

Fig. 54: Early Harappan: short-necked pottery

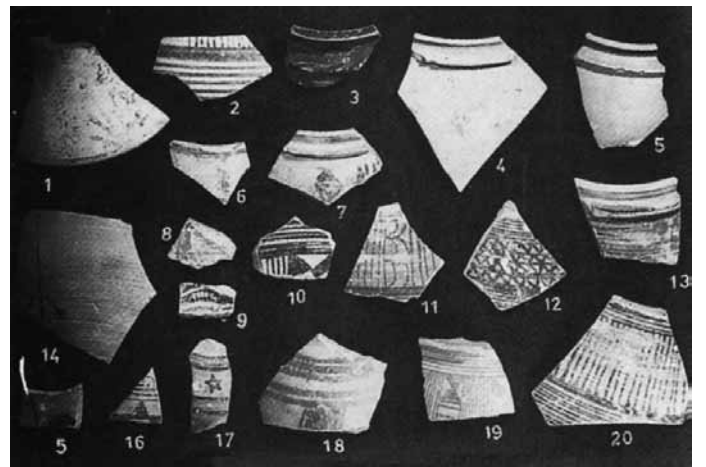

Fig. 55: Early Harappan: painted pottery with plain, painted or grooved surface and pieces of flanged vessels



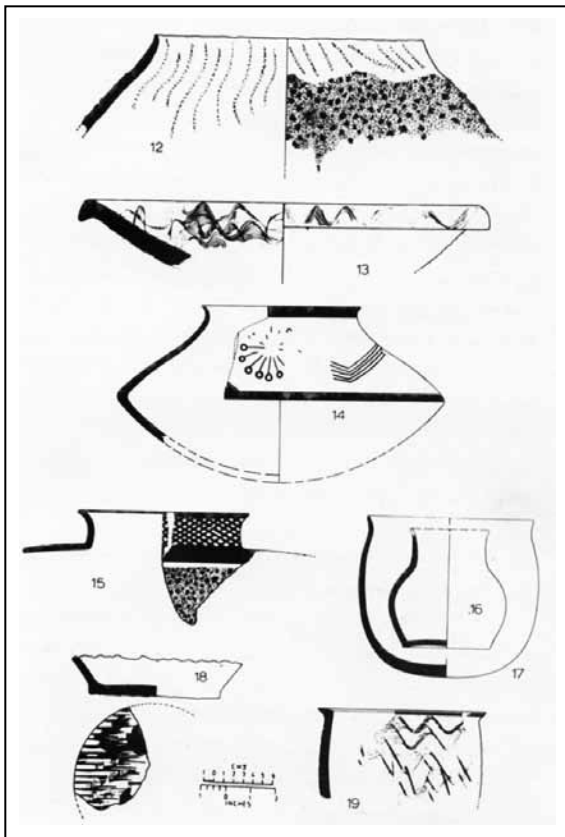

Fig. 56: Pottery of the Hakra wares period

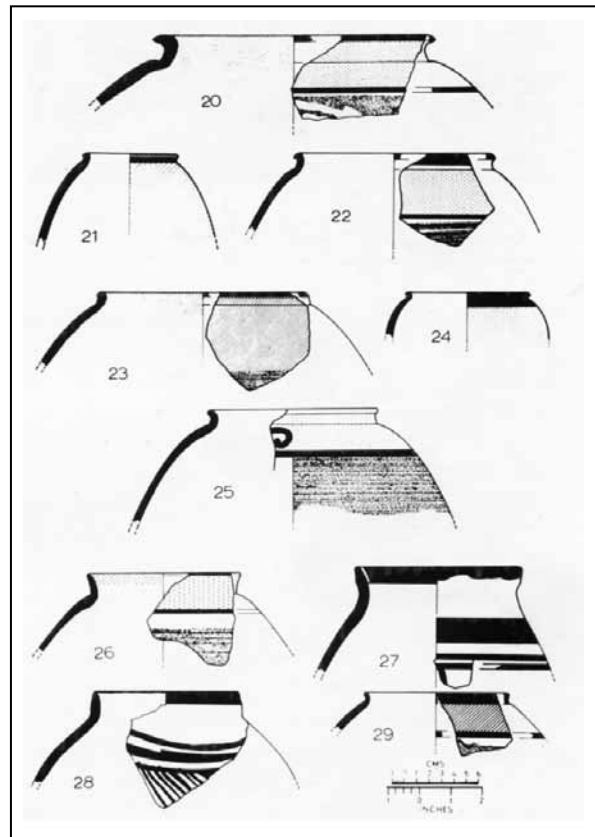

Fig. 57: Pottery of the Early Harappan period

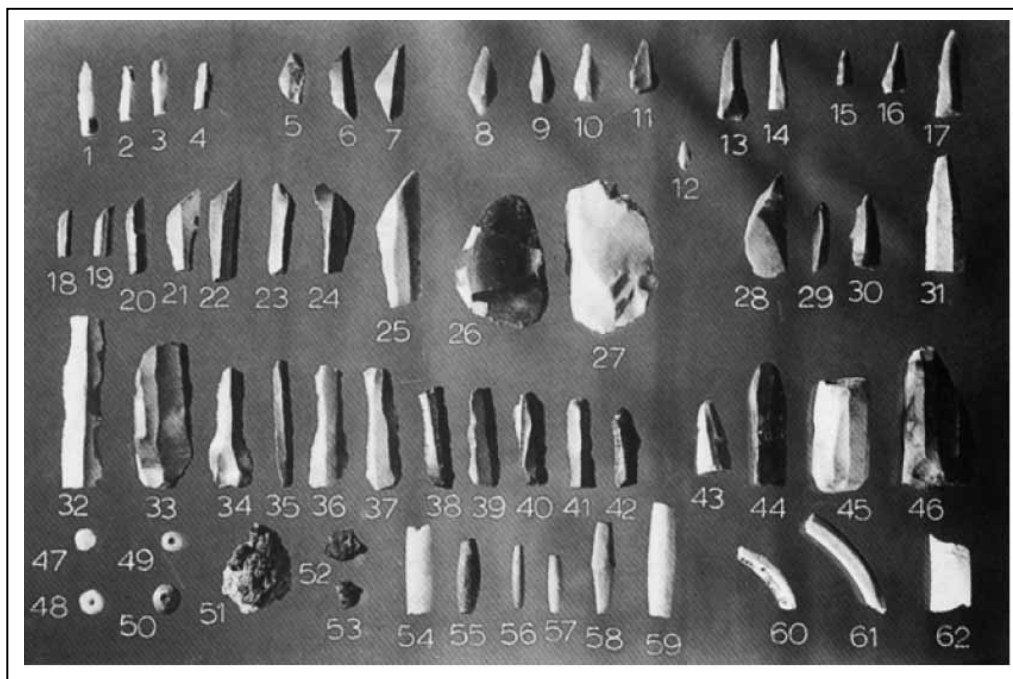

Fig. 58: Lithic materials associated with the Hakra wares (Nos. 1-46); and beads of terracotta, stone, bits of copper and shell pieces (Nos. 47-62) (courtesy: Mughal).



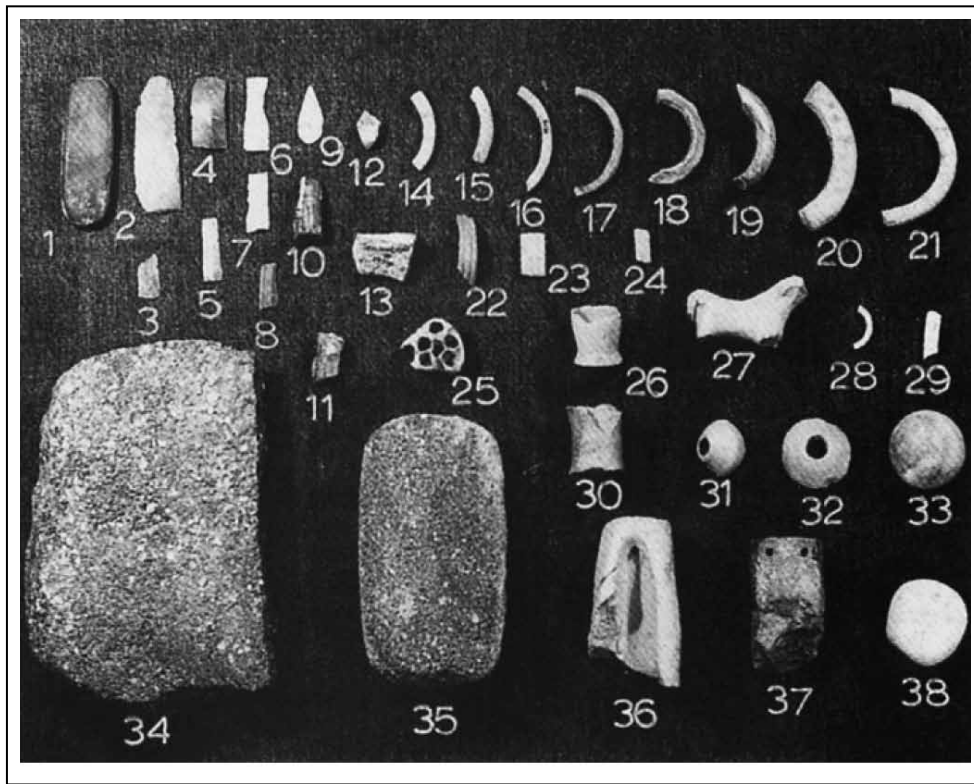

Fig. 59: Stone mullers, Lapis Lazuli (Nos. 12 and 13), terracotta, shell objects of the Early Harappa period (courtesy: Mughal).

Archaeological Survey of India from 2002-2005 (Sant *et. al.* 2005: 50-59, Trivedi 2009: 256).

KALIBANGAN

In northern India for the first time, in the year 1960-61, the cultural antiquity of the 'Lost' river Sarasvati was pushed back to earlier levels before mature Harappans by the excavations at Kalibangan in District Shri Ganganagar (Rajasthan) located on the left bank of the Ghaggar (ancient Sarasvati river) usually dry, but occasionally flooded. In subsequent excavations at the site, a deposit of 0.85 cm overlying the natural soil confirmed definite elements of a pre-Harappan culture with three

structural phases wherein the brick sizes were significantly different from those of the Harappa culture (Fig. 60). It revealed a pottery which was also obtained from the pre-defence levels at Harappa and also from the lowest levels of Kot Diji but a clear picture of this evolution could not be confirmed at that time including that of other associated industries (Lal and Thapar 1967: 78-88). This particular pottery found at this site was widely prevalent on the sites in the Sarasvati and Dhrisadwati valleys (Fig. 61). Other finds included blades, terracotta bangles, steatite beads and a piece of copper in the late levels of this culture. Later on the pottery of this phase was divided into six fabrics and the most prolific was dull red



to light pink and was often supplemented with white paintings comparable to Kot Diji (Khan 1965). In period I, all the six fabrics of the Early Harappan were noticed but there are no details of their stratigraphic position in relation to the emergence of individual fabric (Plates 10-15). The site was a fortified settlement having grid system of planning, fire altars and burials outside the area of settlement.

Joshi has noticed while writing the excavation report some sherds akin to Hakra and a few greyish sherds and knobbed wares comparable to Rehman Dheri I. This development has been termed by Joshi a regional dynamism leading to a revolutionary process (Lal *et. al.* 2003: 22). The Early Harappans identified with Sothi-Siswal complex having its counterpart in Cholistan and Kot Diji ceramics continued to live with Mature Harappan for sometime in the Lower town at Kalibangan.

There are twelve C 14 dates for Kalibangan, out of which five are from the late levels, one from middle and rest six are from early levels (Table 2). In an overall assessment the excavators have assigned a time bracket for the early Harappans between c. 3000 – 2700 BCE. However, two of the samples TF-156 and TF-439 were also rerun by the Birbal Sahani Institute of Paleo-Botany, Lucknow. The sample from the early Harappan deposit TF-439 has provided a time bracket between c. 5600 – 5224 BCE (Lal *et. al.* 2003: 25-26). However, there is a long gap between this early date and other dates and we have to wait for new archaeological

material from other neighbouring sites to reach any definite conclusion, but the time bracket for early Harappan period has to be extended back.

SOTHI

Ghosh excavated Sothi in the year 1950-51. He laid a trench STH-A on the top of the mound which has revealed an occupational deposit of about 60 cm whereas STH-B which was on the slope yielded only 30 cm deposit. Another trench STH-D yielded a maximum deposit of 2.50 m divided into 10 layers. The concentration of potsherds was noticed up to layer 6. However, only three sherds were found percolated in layers 8, 9 and 10, but these layers were completely devoid of any habitational sign (Section drawing courtesy: A Ghosh) (Fig. 62).

In 1978, a trial trench of 2 x 2 m was laid by the present writer on the western side of the mound (Dikshit 1980: 32-43). The trench was dug up to the depth of 3.40 m. A deposit of loose earth from surface to 0.50 m consisted of mixed pottery – Harappan and Sothi, whereas from 0.50 m to 0.70 m it was only Sothi (Fig. 63). The loose earth was found mixed up with clay patches. From 0.70 m to 1.30 m the potsherds were scarce but beyond 1.30 m, up to 3.40 m the loose earth was without any pottery. However, in this trench no compact earth was encountered.

A trial trench of 2 x 2 m was also laid at Nohar. The mound was found merging with the surrounding sandy land except for some bulge in the centre. The results obtained was nowhere different than what



Table 2: Radiometric dates from Kalibangan

Stratigraphic Level	Sample No.	Based on 5568-year half-life	Based on 5730-year half-life	Calib-3 correction (1 Sigma & 2 Sigma)
Late	TF-957	2355+/-200 BP	2425+/-205BP	1 Sig BC 782 (398) 185 2 Sig BC 900 (398) AD 70
Late	TF-154	3665+/-110 BP	3770+/-115 BP	1 Sig BC 2192 (2029, 1994, 1987) 1886 2 Sig BC 2395 (2029, 1994, 1987) 1741
Late	TF-156 (BS)	4010+/-165 BP	4130+/-170 BP	1 Sig BC 2867 (2553, 2543, 2493) 2287 2 Sig BC 2917 (2553, 2543, 2493) 2034
Late	TF-156	3740+/-105 BP	3850+/-110BP	1 Sig BC 2287 (2137) 1974 2 Sig BC 2462 (2137) 1789
Late	TF-165	3800+/-100BP	3915+/-105 BP	1 Sig BC 2450 (2200) 2041 2 Sig BC 2489 (2200) 1934
Middle	TF-161	3930+/-100 BP	4050+/- 105BP	1 Sig BC 2563 (2457) 2280 2 Sig BC 2853 (2457) 2059
Early	TF-240	3610+/-110 BP	3720+/-115 BP	1 Sig BC 2132 (1944) 1776 2 Sig BC 2281 (1944) 1680
Early	TF-162	3940+/-100 BP	4060+/-105 BP	1 Sig BC 2568 (2459) 2284 2 Sig BC 2857 (2459) 2137
Early	TF-241	4090+/-90 BP	4215+/-95 BP	1 Sig BC 2869 (2611) 2486 2 Sig BC 2888 (2611) 2404
Early	TF-157	4120+/-110 BP	4245+/-120 BP	1 Sig BC 2880 (2850, 2825, 2655, 2645, 2622) 2493 2 Sig BC 2918 (2850, 2825, 2655, 2645, 2622) 2362
Early	TF-155	4195 +/-115 BP	4320+/-120 BP	1 Sig BC 2911 (2872, 2792, 2777, 2713, 2708) 2586 2 Sig BC 3072 (2872, 2799, 2777, 2713, 2708) 2465
Early	TF-439 (BS)	6507+/-125 BP	6700+/-130 BP	1 Sig BC 5566 (5436) 5289 2 Sig BC 5600 (5436) 5224
Early	TF-439 Same as in the case of TF-439 (BS)			

was noticed at Sothi divided into two periods: early Harappan (Sothi) and mature Harappa (Fig. 64).

SISWAL

The site at Siswal, district Hissar is located at a distance of 26 km west of Hissar in Haryana.



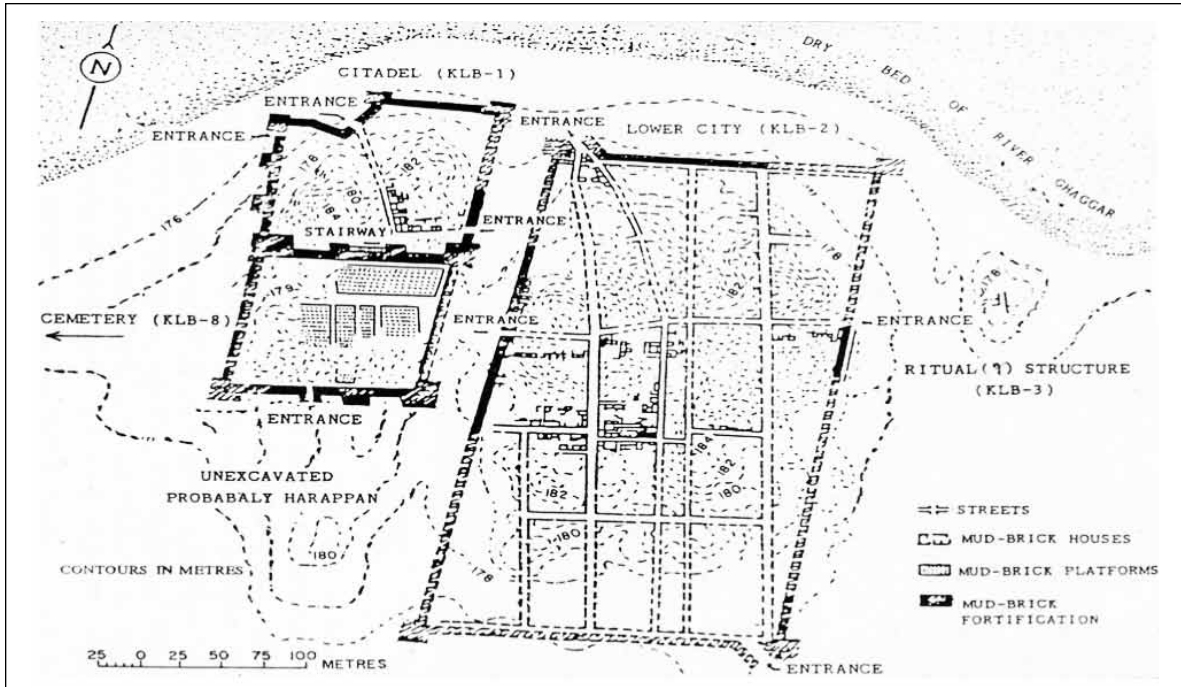

Fig. 60: Kalibangan: Harappan settlement, period II

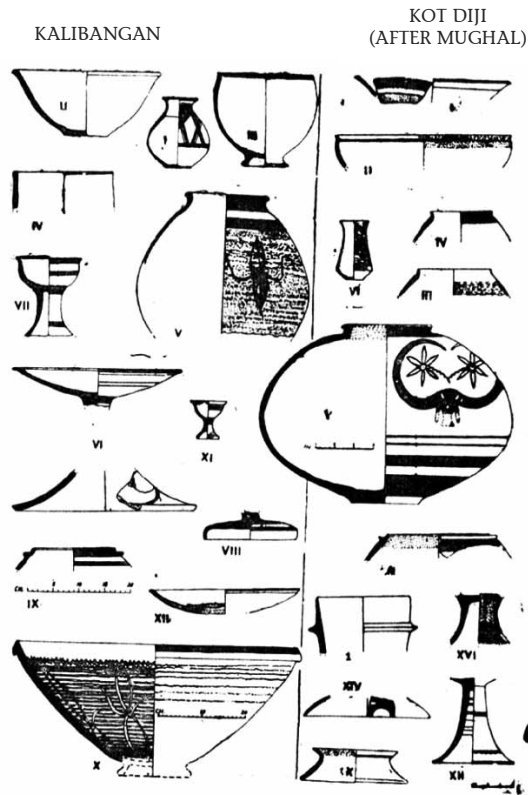

Fig. 61: Main forms from Kalibangan and Kot Diji

A trench measuring 2 m sq was put on the western part of the mound which revealed a culture deposit of 1.25 m divided into five layers. On the basis of the classification of pottery, these layers were divided into two phases. The lower phase A from layer 2 to 5 is characterised by the fabric of Kalibangan I including white paintings, whereas phase B yielded more evolved rather sturdy shapes, paucity of types and designs and also absence of white painting (Fig. 65). The phase B has been connected with Mitathal I (see figure). No microlithic blades or copper objects were found (Bhan 1971-72: 44-46).

BANAWALI

Excavations at Banawali, located on the right bank of the river Sarasvati in district Fatehabad (earlier Hissar), Haryana has yielded a continuous sequence of Harappan



culture, *i.e.* the Pre-Harappan now called Early Harappan (periods IA and IB), proto-Harappan or transitional (period IC), Mature Harappan (period II) and the post-Harappan (period III). The period IA (Pre-defence phase) is represented by fabric 'A' of Kalibangan I, finer in quality in terms of clay, baking, lightness, surface treatment and painted motifs. Usual building material was the standardised sun-dried moulded bricks set in mud mortar. The house walls followed nearly the cardinal directions.

Period IB (Defence stage) starts with the construction of a comparatively thin boundary wall around the settlement. Later on, the boundary wall was built into a massive fortification wall at its apex in the north. The antiquities of this period are continuation of earlier period namely beads of lapis lazuli, carnelian, steatite, and clay, a bone handle probably for drill bits, fragments of two bone spatulae and one copper fish-hook and one arrowhead. (for

Banawali material courtesy: RS Bisht)

In period II at Banawali, the mature Harappan integrated both the Citadel and Lower town by using a common wall, the Citadel formed a sort of semi-ellipse and occupied nearly half of the entire area (Fig. 66). The houses followed the usual pattern of having a courtyard with rooms around it. With typical mature Harappan pottery it also yielded variety of antiquities including copper objects, beads, bangles, seals and sealings and weights including beads of carnelian, lapis-lazuli and gold. The site was also occupied in the post Harappan period (Figs. 67-72).

BALU

Excavations at Balu by U.V. Singh and Suraj Bhan yielded three phases of occupational deposit. Phase A, consisting of an average occupational deposit of one metre is represented by a ceramic industry of pre-Harappan tradition, comparable to

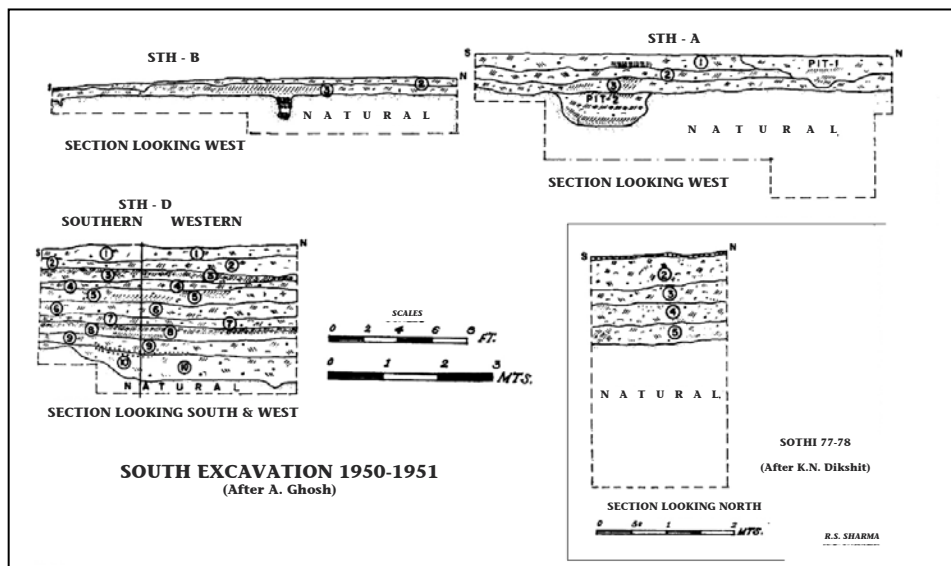

Fig. 62: Sections of Sothi Excavation 1950-51 and 1977-78



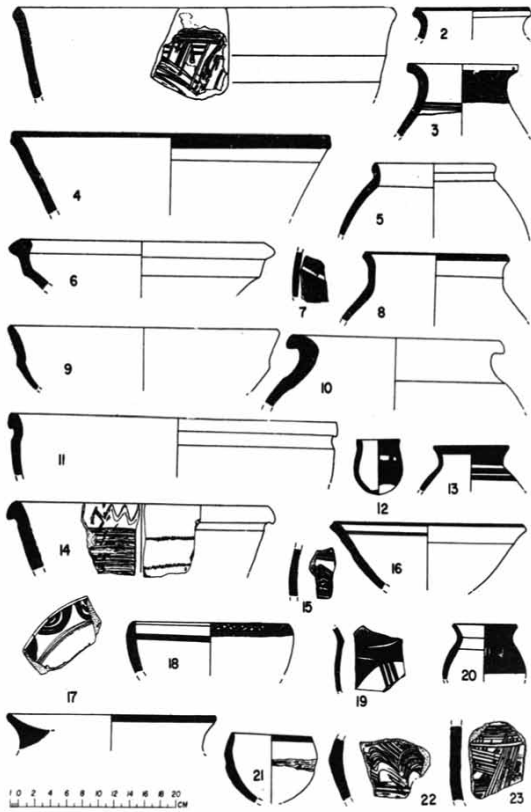

Fig. 63: Sothi: Early Harappan wares

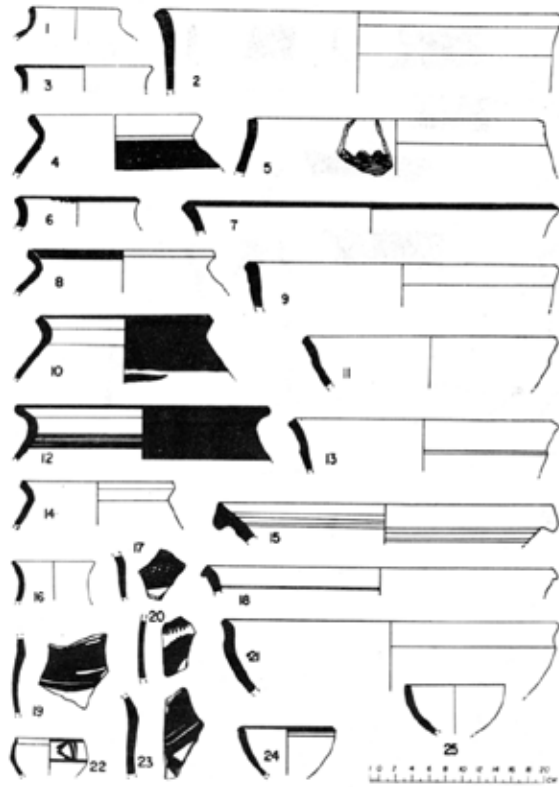

Fig. 64: Nohar: Early Harappan wares

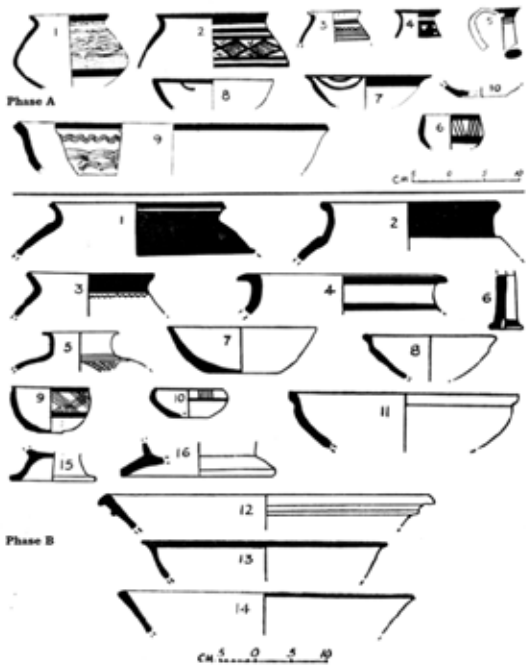

Fig. 65: Siswal: Pottery, Phase A and B

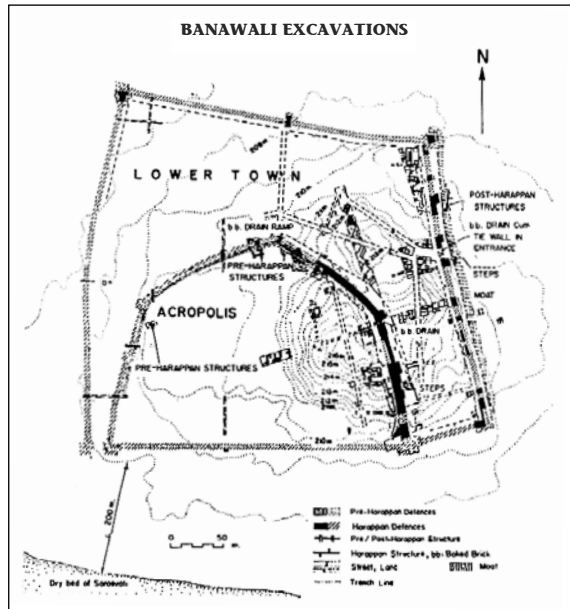

Fig. 66: Banawali Excavations



late Siswal ceramics, and antiquities like terracotta cakes and bangles and steatite beads. No house structure was noticed, but mud bricks of 30 X 20 X 10 cm were encountered.

Phase B continued for a longer period as revealed by the occupation of 2.20 metres, distinguished by mature Harappan pottery with continuation of the ceramics of the preceding period. The structural remains include massive mud brick platform and a few domestic structures constructed of sun-dried bricks.

The phase C having 1.3 meter deposit yielded pottery traditions of earlier phases with the emergence of new types of late Harappan complex comparable to Bara and Mitathal IIB. The structures include a house-drain built of wedge-shaped mud bricks. A few shell bangles with other objects of the Phase B continue to occur (IAR 1978-79, IAR 1979-80, Kesarwani 2002).

RAKHIGARHI

Excavations at Rakhigarhi, located in the drainage systems of ancient Sarasvati-Drishdvati rivers, revealed all the phases of the Harappan civilisation, i.e. period I (Early Harappan), period II (Mature Harappan) and period III (Late Harappan). The structures of the period I are oriented along the cardinal directions and are built with burnt and sun-dried bricks. There are three structural phases within this period (Fig. 73). Important structures include drainage systems, floor of courtyard, circular pits, fire chambers etc.

The ceramics industry has all the six



Fig. 67: Terracotta animal figurines, Period I

fabrics of Kalibangan and were also noticed at Banawali 1. Some sherds also compare with the Hakra ware. Important antiquities are arrowhead, needle and bangle of metal, chert blade, objects of terracotta like bangles, animal figurines, toy-cart frames and hopscotch, saddle querns, beads of steatite and faience etc. (for Rakhigarhi material courtesy: Amrendra Nath).

Period II is represented by mature Harappan period and has yielded structures such as citadel, mud brick fortification wall, mud brick podium, fire altars, public and house hold drains, courtyard etc. The pottery tradition is characterised by typical Harappan wares and the shapes (Figs. 74-75).

Period III, the late Harappan occupation is indicated by the surface observations but in actual stratification, it was not encountered. It may be of a short lived nature practiced by a small group (Nath 1997-98, 1998-99).

The charcoal samples twelve in numbers were sent for C 14 dating to Birbal Sahni Paleobotany Institute, Lucknow. They have



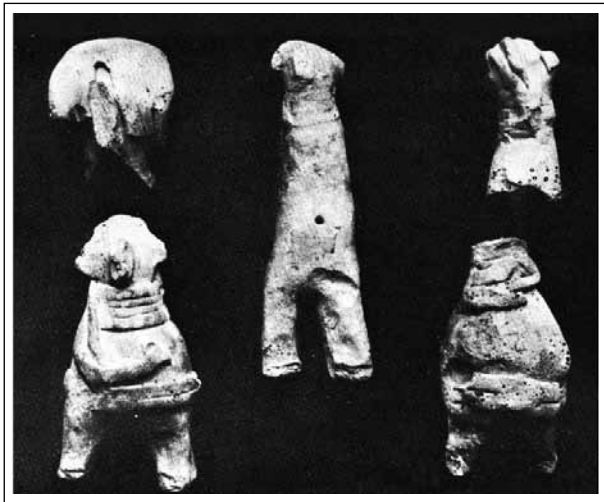

Fig. 68: Terracotta, human figurines, Period I



Fig. 69: Terracotta, addorsed bull, Period II B

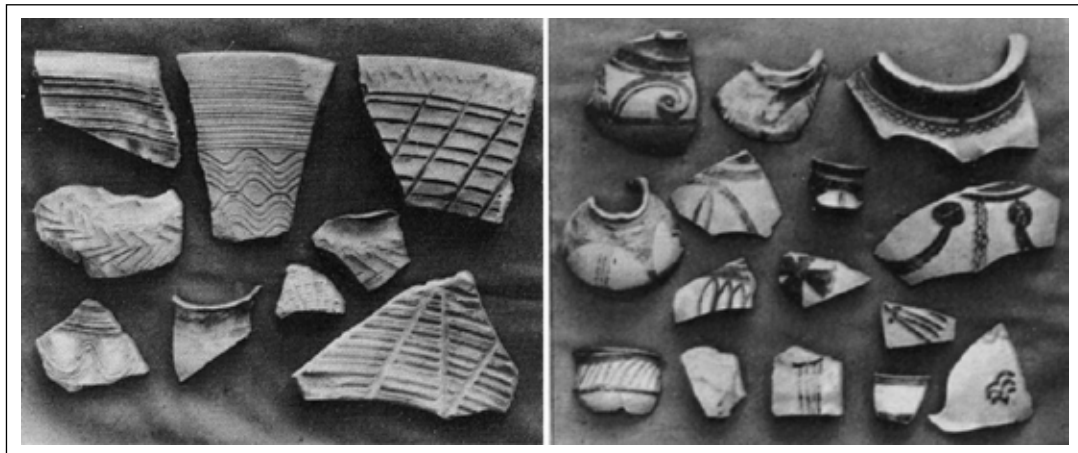

Fig. 70: Steatite seal and sealing, Period II

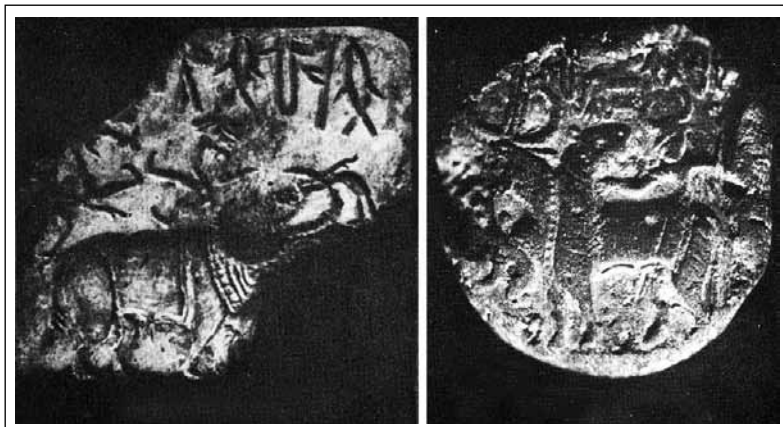

Fig. 71: A terracotta sealing, Period II

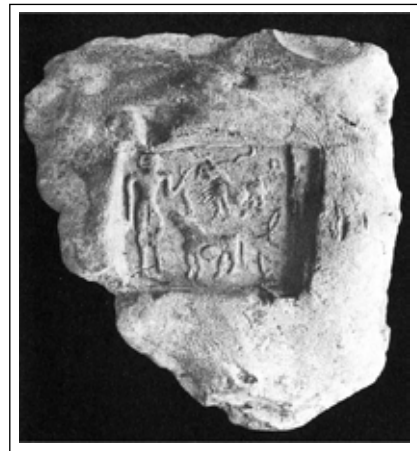

Fig. 72: Banawali: Early Harappan pottery



supplied the radio carbon dates including the calibrated (BP). (Table 3)

However, in the study of these dates, the earliest could be placed to the end of the 5th millennium BCE and others fall in

line with the accepted time bracket of the Harappan Culture. After usual deduction, the dates are in the time bracket between c. 4230 BCE – 2140 BCE which presents a kind of consistency.

Table 3: Radiometric dates from Rakhigarhi (courtesy: Amrendra Nath)

SIM	BSIP Ref	Ref No.	Radiocarbon Age (Yrs BP)	Calibrated Age (Yrs BP)
S-4168	BS-3313	No.86, RGR-2, 1080 CM	5410+-100	6180+-50
S-4169	BS-3314	No.43, RGR-1, 3.2-3.3 CM	5230+-90	6030+-40
S-4179	BS-3323	No.223, RGR-2, 8.45 m	3910+-100	5350+-100
S-4180	BS-3324	No.213, RGR-2, 8.45 m	5200+-100	5910+-130
S-4181	BS-3325	No.155, RGR-2, 0.74CM	4690+-120	5450+-80
S-4186	BS-3340	No.59, RGR-1, 2.70 M	3740+-70	4090+-80
S-4188	BS-3342	No.51, RGR-6, 4.32 M	4950+-310	5680+-340
S-4190	BS-3344	No.46, RGR-1,	4570+-100	5230+-60
S-4191	BS-3345	No.37, RGR-1, 2.55-2.70 M	4430+-80	5060+-40
S-4197	BS-3350	No.28A, RGR-1, 200-205 CM	4650+-90	5410+-90
S-4199	BS-3352	No.35, RGR-1, 240-250 CM	3840+-70	4270+-60
S-4200	BS-3353	No.43, RGR-1, 320-330 CM	3810+-70	4200+-100

In case of these dates one has to quote the opinion of the laboratory that to obtain the correct age in BCE/CE by subtracting 1950 from the age in BP may not give the correct age in BCE/CE due to the non-linear behaviour of the calibration curve. For this one should use standard calibration programme such as Calib 4.4 made available by the University of Washington. This latest calibration may give more correct dates for assigning the antiquity of the site.



Fig. 73: Rakhigarhi : General view of the excavated trenches (RGR 2) showing structural remains of the Mature Harappan phase





Fig. 74:Rakhigarhi: Seals and amulet from the mature Harappan phase

KUNAL

A pre-Harappan site on the Sarasvati was excavated between 1991-92 and 94-95. (Khatri and Acharya 1994-95: 84-86). In the lowest level (IA), the round subterranean pits were found with a refuse pit. These are 2 m. in diameter and 1.10m. in depth with rammed floor and smoothed walls. A few post-holes were also noticed around the dwelling pits suggesting rising of a hut above the pit. It yielded so called Hakra wares and also a handmade black-and-red ware, a dull chocolate coloured burnished ware with parin marks, and a dull red ware with wavy incised decorations on the outer surface.

Another noteworthy pottery is the dull red with a black outline and white filling also found at Banawali, Kalibangan and Kot Diji, whereas at Bhirrana, it was in association with Hakra ware in the upper levels not inside the dwelling pit (Plate 16). It has faunal and floral painted motifs including stylised bull head and decorated horns. In a later stage, a variety of *pipal* leaf also makes the appearance (Plate 17). Other

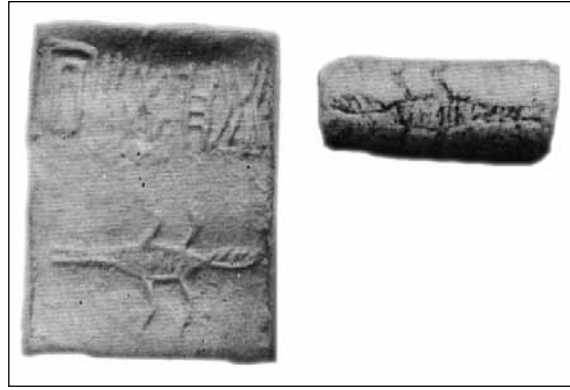

Fig. 75: Rakhigarhi: Faience cylindrical seal from the upper mature Harappan phase, Rakhigarhi

objects include bone tools, micro beads and arrowhead and fish-hooks of copper.

In period IB, the dwelling pits expanded in diameter and were found lined with finely moulded mud-bricks not conforming to any standard Early/ Mature Harappan brick sizes. There were well designed mud-brick constructed hearths. The pottery of IA continued with all the six fabrics of Kalibangan I.

In period IC, the pattern of living changed from subterranean to regular and square rectangular houses built of standardized mud-bricks (1:2:3 and 1:2:4) on the ground level. It also developed drainage system with soakage jars fixed in the street pits. In different phases of IC (i)-(iii), dwellings became larger and durable. In one of the house, gold and silver ornaments were found in a globular pot.

There are only three radiometric dates assigning the site between c. 3016 and 2577. As there is no date from the earliest level, the antiquity of the site may be placed to the beginning of Girawad and other sites in the region.



BHIRRANA

Recent excavation on Sarasvati river at Bhirrana from 2003-2004 revealed a gradually evolving Harappan settlement from a modest beginning substantiated by a cluster of subterranean pits using 'Hakra wares' of Cholistan complex along with other fabrics specially mud applique ware. (Rao et.al. 2003-04: 20-24) (Fig. 76). The other material remains of IA were micro and disc beads of steatite, fragments of terracotta bangles and crucible fragments with molten copper. No copper object was reported.

The dwelling-pits which are 14 in numbers are directly cut in the natural soils and are shallow in depth and could

accommodate about 3-4 people. These are plastered with self-same earth of yellowish alluvium. Besides dwelling, these pits were also used for sacrificial/industrial purposes (Plate 18; Fig. 77). In the lower levels of these pits medium to thin bodied wheel-made pots with thick coat of mud called specially Hakra ware or mud appliqué ware (Plate 19) in comparison to incised ware of deep or light incision dominated but in upper levels it was in association with bi-chrome ware (Plate 20-21).

The Hakra ware is not well finished and varies in colours from dull red to grey. The shapes are globular pots and heavy bodied storage jars. In addition to mud appliqué

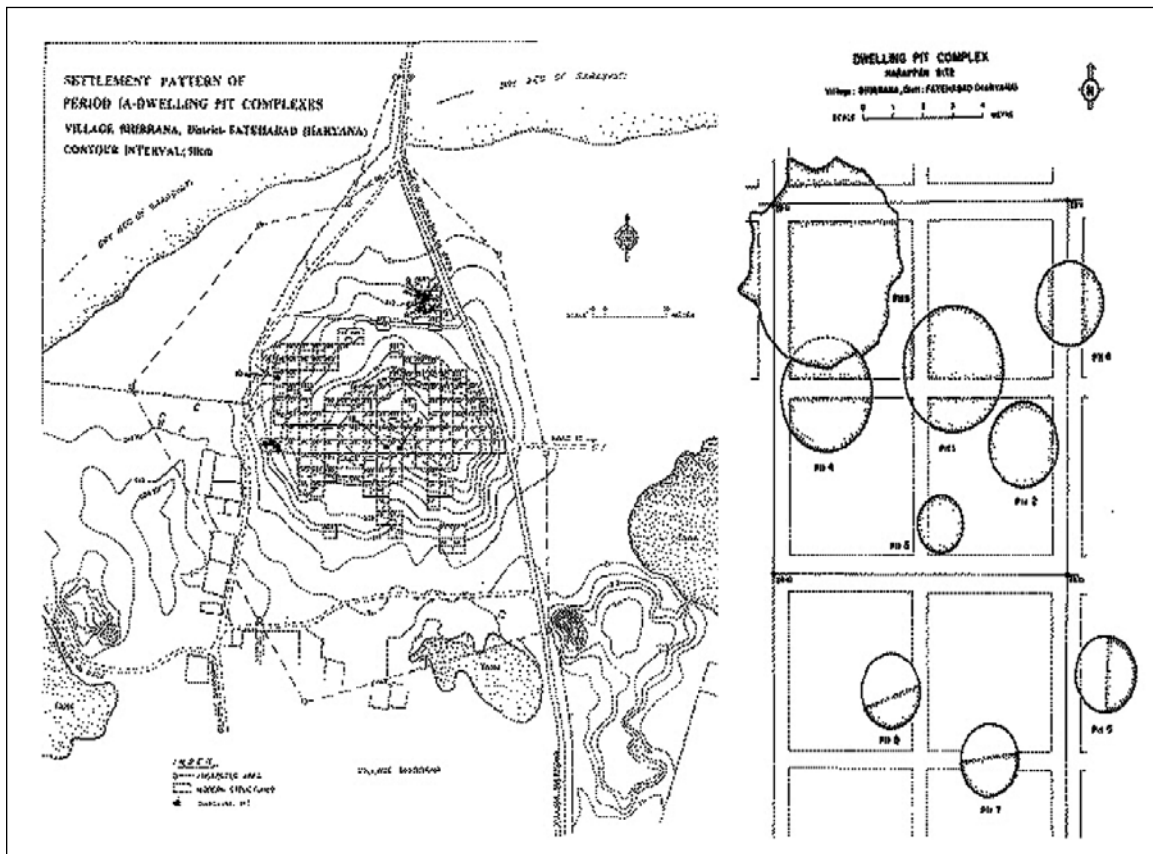

Fig. 76: Location map of Dwelling- pit Complex



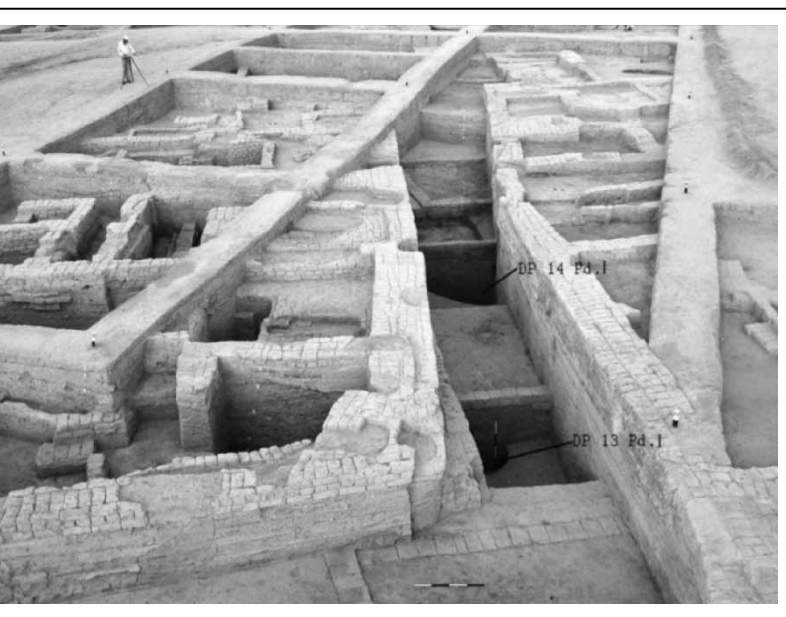

Fig. 77: Bhirrana: Structures of period I (courtesy: L.S. Rao)

ware, it was also having other wares viz. incised ware, tan slipped ware, black burnished ware, brown on buff ware, black-

on-red ware and simple red ware of medium fabric with common shapes like vase, bowl and cup. The shapes in bi-chrome ware were limited to vases and bowls. The outline of the motifs are in black with interior filling in evanescent white (Plates 22-30).

These were followed by the mud-brick structures (1:2:3) of the Early-Harappan (IB) to a full-fledged maturity tracing the fortification wall of Early Mature Harappan (IIA) and Mature Harappan (IIB) to a length of 95 m with a width of 5 m having 17 courses rising to a height of 1.80 m with a plaster coating on its external face (Fig. 78).

It further revealed house-complexes, streets and lanes and a number of stylized terracotta animal heads with incurving horns having rectangular cross sections. These also have bold perforations on the

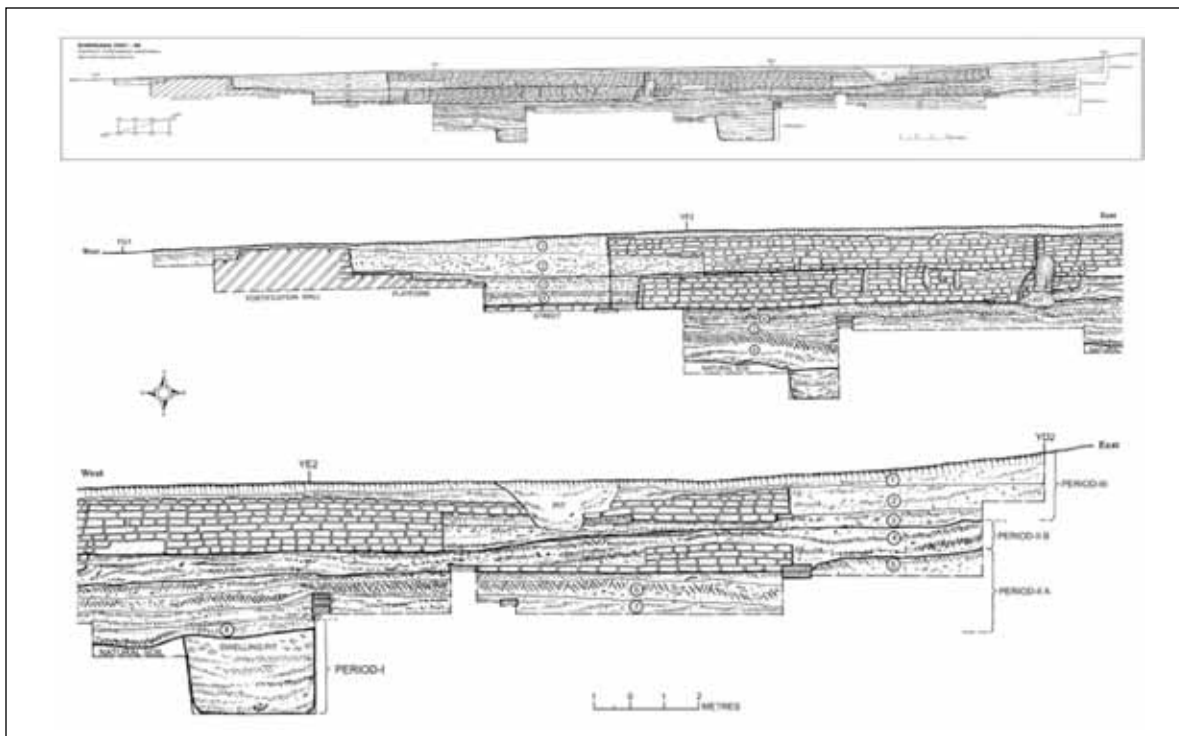

Fig. 78: Bhirrana: Section Facing South



snout portion and varying numbers of perforations over the forehead and further extended on to the horns.

Four mature Harappan steatite seals depicting a three-headed animal, those of a bull, unicorn and a deer with a standing deity were found. One of the seals was on black steatite. Mention be also made about the fragment of a thick sturdy red ware bearing an incised figure of a dancing girl and also single hub wheels some with spokes painted in black (Plate 31; Fig.79).

The Carbon 14 samples from Bhirrana

have pushed back the antiquity of the region to a hoary past comparable to other places like Mehrgarh in Pakistan. The C 14 dates outline a continuous habitation at the site till the end of Harappans. It has a long desertion of the mound till the advent of medieval period. The samples were sent to Birbal Sahni Institute of Paleobotany, Lucknow for calibrating the dates. Due to sudden demise of the excavator, the C14 dates could not be published earlier. The calibrated dates were received in two lots (Table 4).

Table 4: C¹⁴ dates from Bhirrana, district Fatehabad, Haryana

Sample ID	BS No	C ¹⁴ Age (Yr. BP)	(1 Sigma) Yr. BP	Yr. BCE
BRN 1	2308	3300 ± 200	3826 - 3274	1878 – 1839
BRN 2	2327	40 ± 80	31- 93	Contaminated
BRN 3	2310	3190 ± 160	3629- 3214	1641 – 1287
BRN 4	2311	3890 ± 90	4442 - 4153	2471 -2273
BRN 5	2318	6120 ± 250	7286 - 6671	5316 - 4775
BRN 6	2333	7590 ± 240	8597 - 8171	6689 -6201
BRN 7	2314	5700 ± 170	6720 - 6303	4714 – 4360
BRN 8	2301	4050 ± 90	4806 - 4418	2856 - 2414
No.8, BRN 1	2485	4450 ± 170		3370-2890
No.7, BRN 1	2492	4230 ± 100		2920 – 2640
No.3, BRN 1	2494	3750 ± 110		2310 – 1980
No.2, BRN 1	2495	4160 ± 100		2880 – 2580
No.1, BRN 1	2496	4340 ± 120		3100 – 2880
No.5, BRN 1	2497	4280 ± 110		3020 - 2700
No.4, BRN 1	2499	3490 ± 120		1950 – 1640
BRN 9	2481	8350 ± 140		7570 – 7180
BRN 6	2482	4990 ± 180		3970 – 3640
KRN(K)	2502	7150 ± 130		6200 – 5850



ASSESSMENT OF DATES

A review of radiometric dates revealed a continuous cultural development at the site from the middle of 8th millennium BCE to 16th century BCE. The arrangements of these dates has been adopted for understanding the cultural gaps, if any at the site which requires further confirmation from other sites excavated in recent years such as Farmana, Girawad and Rakhigarhi. A general impression appears that the time bracket of Early Harappan proposed in the past for sites like Harappa, Kot Diji and Kalibangan requires a longer span of life namely from c. 4500-3000 BCE which will be more appropriate in understanding the

cultural process in Sarasvati, Ravi and in the lower levels of Indus valley. These dates fill-up the cultural gaps in the region. The material culture of dwelling pits – period IA continued in period IB with the settlements coming up on ground level with introduction of new fabrics and shapes. As cultural development appears to be slow and showing no sign of break, the fabrics of early Harappans started emerging towards the end of period IB. This cultural continuation has to be confirmed from the excavations of other sites in the region including Bahawalpur area in the adjoining Pakistan. This is a proposed tentative time bracket for the growth of settlement at Bhirrana (Table 5).

Table 5

Classification of dates from Bhirrana	Relative Chronology	Time Bracket
I 7570-7180 BCE 6689-6201 BCE	Period I (Neolithic)	IA C. 7500-6000 BCE
II 6200-5850 BCE 5316-4775 BCE	Period IIA (Transitional Period) (from dwelling pits to ground level)	IB C. 6000-4500 BCE
III 4714-4360 BCE 3970-3640 BCE 3370-2890 BCE 3100-2880 BCE 3020-2700 BCE	Period IIB (Early-Harappan)	IIA C. 4500-3000 BCE
IV 2920-2640 BCE 2880-2580 BCE 2856-2414 BCE 2471-2273 BCE 2310-1980 BCE	Period III (Mature-Harappan)	IIB C. 3000-1800 BCE
1950-1640 BCE 1878-1839 BCE	Period IV (Late-Harappan)	IIC continuation till C. 1600 BCE



Marshall has dated the beginning of Indus Civilization to c 3000 BCE which was the accepted date of this civilization till the renewed excavations carried out by Mortimer Wheeler at Harappa where he dated this culture between c 2350 – 1700 BCE. This shorter chronology was further confirmed by C 14 dates for the excavations carried out later on in Indo-Pak subcontinent especially by TIFR and PRL in India. Now Harappan chronology has been put to scrutiny by the calibrated dates and new excavations.

If the beginning of Harappa culture is accepted c 3000 BCE, as advanced by Marshall, then there is no problem in accepting the above suggested chronological chart for the beginning of early Harappans in Sarasvati valley, whereas in Hakra valley no excavation has been done so far. So is the case of pre-Harappan sites in Gomal plains. Both these areas in Pakistan and India require more radiometric dates from different sites in order to understand the transition from neolithic to chalcolithic stages (c 6000 – 4500 BCE), as mesolithic-neolithic hunter-gatherers took a long time in ushering in the stage of primary urbanization. Still the connected areas of study require more interdisciplinary work in arriving at a definite conclusion.

BAROR

Another excavated site Baror is located in Anupgarh Tehsil of Sri Ganganagar District of Rajasthan (Sant et.al. 2004-05: 50-59). It is about 100 km southwest of Kalibangan. It

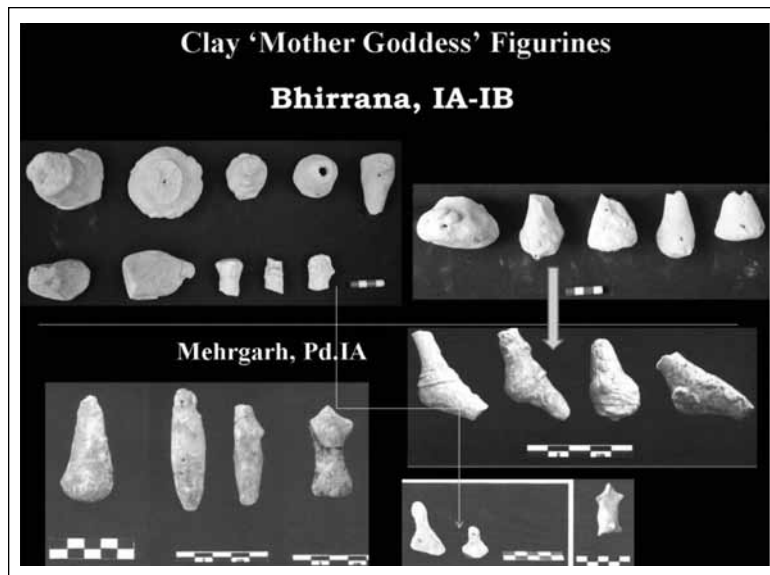

Fig. 79: Bhirrana and Mehrgarh: Comparison of Mother Goddess figurines

also revealed a three-fold cultural sequence- Pre Harappan, Early Harappan and Mature Harappan. However, the excavation did not reveal any subterranean dwellings. The mud-brick structures were encountered but brick sizes do not conform to any regular shape or standard size.

The first settlers i.e. pre-Harappans used to live in huts made of wattle-and-daub in lowest two layers (8) and (9) and were using unpainted red ware, may be non-Harappans of local tradition which was followed by the bi-chrome painted sherds in the upper levels. The next period is the repetition of Kalibangan sequence of Early Harappan and Mature Harappan. The bi-chrome painted pottery and other six fabrics of Kalibangan continued in the Early Harappan period at Baror (For antiquities see Plate 32).





Fig. 80: Girawad: General view of excavated features from west

GIRAWAD

The excavation at Girawad revealed a ceramic assemblage in the lowest level which is similar to those as the Hakra ware in the Ghaggar basin including Cholistan (Shinde, et.al. 2008:77-158). It also revealed about 13 circular or irregular oblong shallow pit-dwellings with post-holes on their peripheries but on the side of these pits, each complex has a storage and a garbage pit (Figs. 80-81).

It appears while pit-dwellings continued, the permanent structures in the form of mud-brick houses on the ground were also used by Hakra ware people. The site has the elements from Amri, Kot Diji and Hakra in the lowest levels of Early Harappan and it is further confirmed with the presence of Periano Reserve Slip and the grooved or cordoned ware in the upper layers of the occupation. The beginning of this site may be assigned in the middle to the late 4th millennium BCE. The area was dominated by the pottery –

kilns (Plate 33-34)

The excavation which was started in 2006-07, also revealed in the lowest levels, pit-dwellings in the Early Harappan level and gradually transformed from subterranean dwellings to over ground rectangular mud-brick structures. (Shinde et.al. 2008: 77-158). Thereafter the site revealed the remains of Mature Harappan period with the continuance of earlier ceramic which has contribution to the making up of the Harappa culture.

The Mature Harappan period is divided into IIA, IIB and IIC. The last phase IIC completely was removed by ploughing the field. Mention be also made about the excavation of a cemetery at Farmana in Haryana which has revealed 70 burials so far and has been assigned to Mature Harappan phase such as Kalibangan, Rakhigarhi or R-37 at Harappa. These burials at Farmana revealed different types of burial culture (Plate 35-37; Fig. 82).

NORTH GUJARAT

In recent years North Gujarat presented important material for understanding the cultural developments in this area especially during the early chalcolithic period (Ajithprasad 2011; 1-40). The mesolithic hunter-gatherers using microlithic tools were found existing before the Chalcolithic farming communities in the area. The excavations carried out at Loteswar and other sites of Anarta tradition mark the arrival of indigenous farming communities through some sort of agricultural production.



In the early phase the technology of pottery and the manufacturing of crested ridge blades were noticed datable to c. 3600 BCE. This cultural gamut has a close kinship between the farming communities of the Indus and the Ghaggar-Sarasvati valleys. This complex was further noticed at Padri and pre-Prabhas levels in Saurashtra coast (Fig. 83). This chronology clearly outlines the stages of cultural developments which were taking place in this area and requires consistent work to know the antiquity by taking excavations at selected sites.

LOTESHWAR

The excavation at Loteshwar revealed a habitational deposit ranging hardly 20-40 cms having non-Harappan ceramic industry. It also revealed a variety of circular pits varying from 0.50 - 2.00 m. in a corresponding variation in depth from 0.50-2.00m. having plenty of ash and other material including pottery, skeletal remains of animals, steatite micro-beads, shell and semi-precious beads, terracotta objects and burnt clay lumps having reed impressions. Similar pits were also noticed at Nagwada and Santhli. The radio-carbon dates from this deposit provide a date c. 3600-3000 BCE. Below this chalcolithic habitation a substantial deposit of mesolithic occupation was also encountered datable to 4700 BCE, but a series of new dates (AMS estimation) put the beginning of mesolithic at the site to 7000 BCE (Patel 2008: 123-134).

The pottery of this period (Anarta pottery) from Loteshwar consists of coarse



Fig. 81: Girawad: Pit-dwelling nos. 5 & 6, from south

Red ware with matt surface, coarse Grey ware (incised) Gritty Red ware, fine Red ware (bichrome-black on white) coarse Red ware, burnished Grey/Black ware and Reserve slip ware. Stratigraphically the Anarta deposit appears directly overlying the Mesolithic deposit without any break but this fact has to be ascertained from other sites (Ajithprasad and Sonawane 2011: 223-266) (Figs. 84-85).

PADRI

Situated on Gulf of Khambat on the Saurashtra coast, the site was excavated by Shinde (1991-1993) which also falls in the regional pre-Urban Harappan ceramic phase. The material noticed from pre-Prabhas level and Padri assemblage namely the gritty and fine red wares put it in the bracket of Anarta pottery tradition. Radio-carbon dates from Padri show a very early date going back to the second half of the fourth millennium BCE. The pottery was





Fig. 82: Farmana: Index Trench ID5 located in the centre of locality 1 showing cultural debris, stratigraphy and features (courtesy: Shinde)

hand modelled or prepared on a slow turn-wheel having thick slip. A variety of bowls and medium sized globular pots having linear and horizontal lines in black pigment were noticed. They lived in houses built of dense clay using copper and lithic blade tools (Shinde 1992: 79-86).

According to Ajithprasad and Sonawane (2011), Anarta pottery tradition was also noticed at Baror (Sant *et.al.* 2005), Bhirrana (Rao *et.al.* 2005) and Girwad (Shinde *et.al.* 2008) and in Ravi phase pottery from Harappa (Kenoyer and Meadow 2000) which confirms that pre-Urban Harappan society and that of the Indus and the Ghaggar-Sarasvati basins had several shared and common cultural traits reflected in their material remains.

MEWAR REGION OF RAJASTHAN

The recent archaeological evidence from

Bagor, Balathal and Gilund suggest that settled life was also emerging in Mewar region contemporary with or even earlier than the pre/early Harappan of Rajasthan and North Gujarat as an internal development within the mesolithic life style of the region and the site like Bagor located on the left bank of Kothari river lies in the semi-arid environmental zone on the foot of small chains of mountainous land. As the Bagor has two phases, the ceramic phase indicated the continuation of blade industry, structural activity and appearance of potsherds (Plate 38). The site of Gilund also revealed a mesolithic phase at the bottom and overlain by a chalcolithic deposit showing beginnings of a village life with agriculture and other ceramics (Misra 1973: 92-100, Shinde *et.al.* 2006: 103-122).

CONCLUSION

The chronological framework as advanced in the paper requires further field work. The areas of Mehrgarh and Gomal plains, Hakra-Sarasvati valley and north Gujarat and adjoining south-eastern Rajasthan clearly suggest that the changing drier climatic conditions affected the life of mesolithic-neolithic hunter-gatherers to pastoralism between the 7th – 5th millennium BCE. These conditions were also responsible in the increase of the human population and settlements around favourable environments which led in the rise of domestication of plants and animals. The Hakra river basin in Cholistan, which is a continuation of 'Lost' Sarasvati valley in Thar desert has yielded a



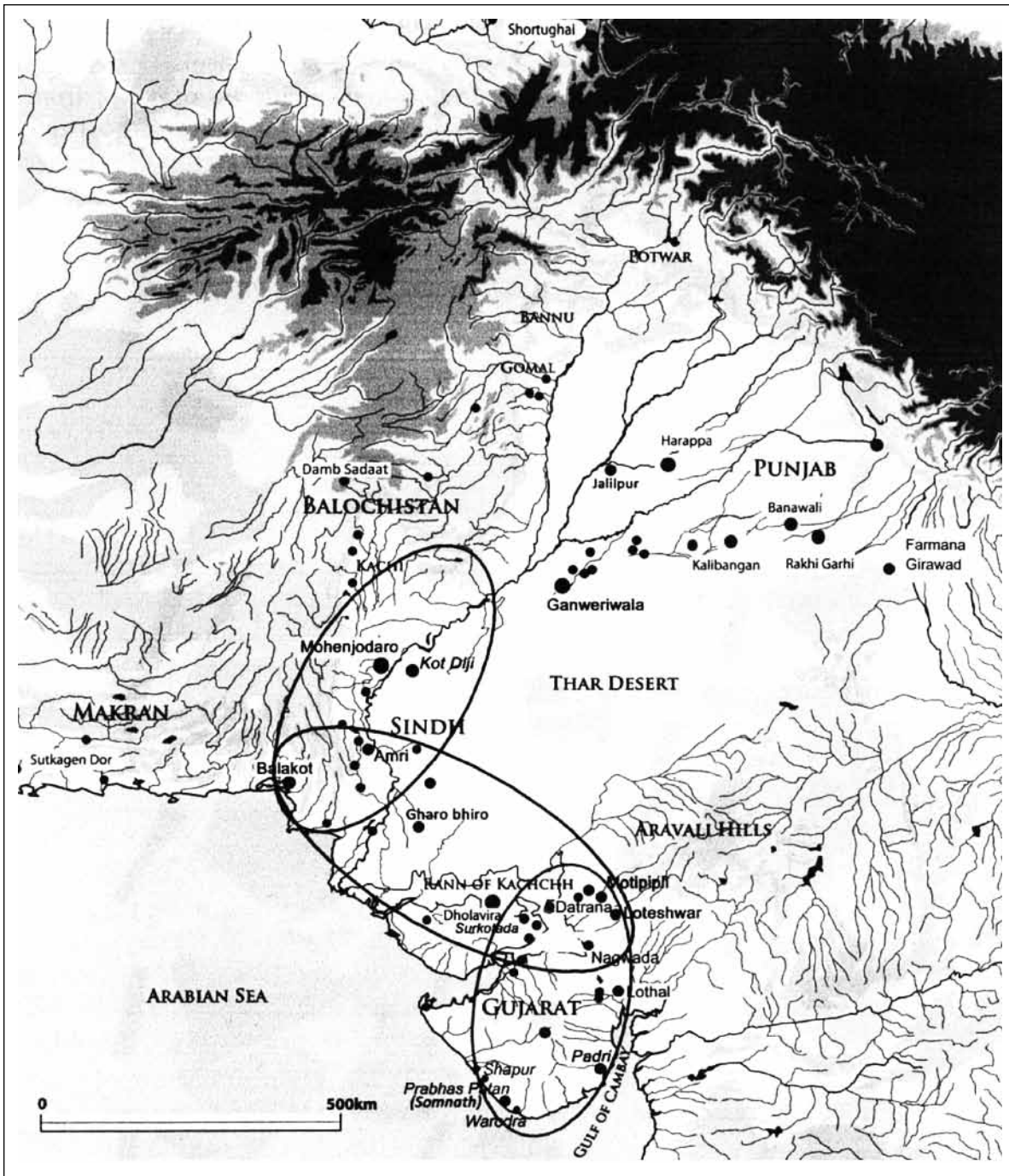

Fig. 83: Early Harappan interactive zones and Gujarat (courtesy: P. Ajithprasad)

set of pottery in exploration known as 'Hakra ware' whose stratigraphic position has now been assigned at Bhirrana in excavation, thereby confirming that the cultural level

achieved in the valley of 'Lost' Sarasvati river is the earliest. It may also clarified that the typical bichrome pottery found from the excavated sites in Gomal plain



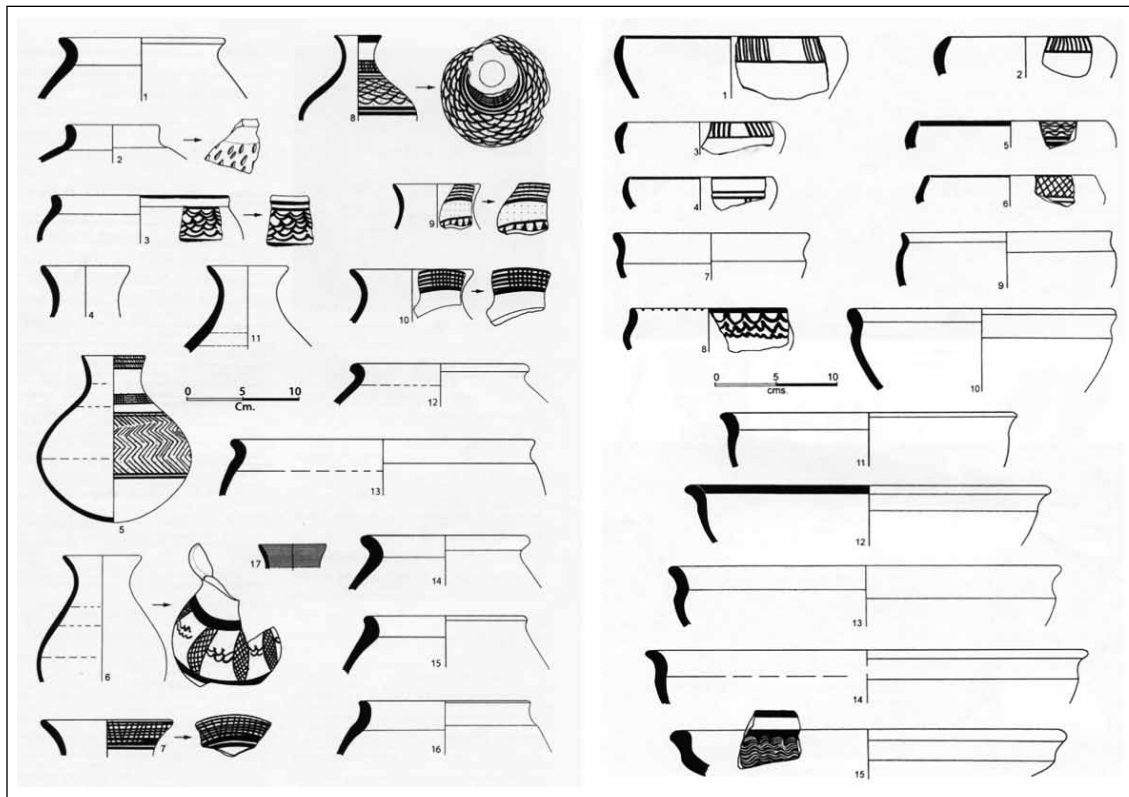

Fig. 84: Loteshwar – I: The Anarta Pottery

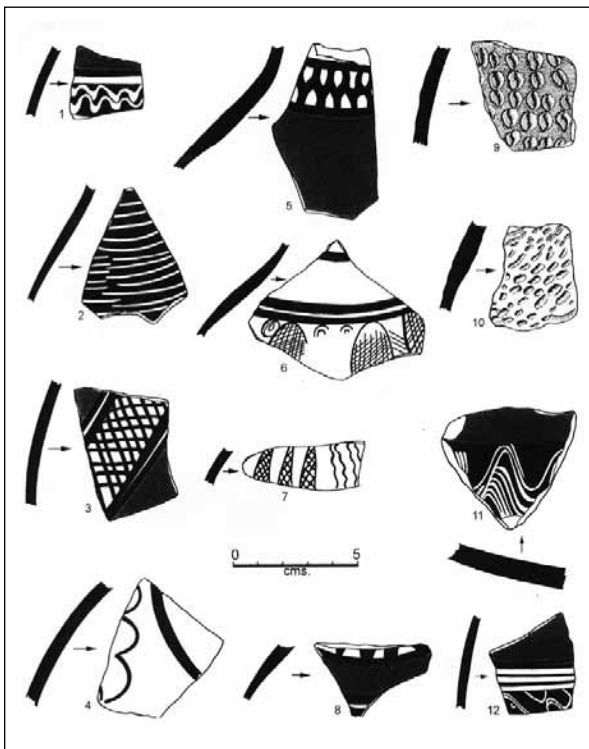

Fig. 85: Loteshwar – I: The Anarta Pottery

has its parallels in Harappa and Jalilpur but in Sarasvati valley its presence is there but not so prominent. So is the case with the mud appliqué pottery found in Hakra-Sarasvati valley, Jalilpur and Harappa which is a prominent ware and is absent in north Gujarat and south-east Rajasthan.

All these pre-Early Harappan stages (especially in northern Pakistan, Sindh, north Gujarat, Rajasthan and Haryana) point to the beginning of primary urbanization in Indo-Pak sub-continent on the lines of a similar developing trajectory as Mesopotamian and Egyptian cultures. A chronological comparison of early Old World civilizations has also been done recently by many scholars in India and Pakistan (Kenoyer 2011).



Moreover, the archaeological data from pre-Early Harappans to early Harappans shows a smooth transition without any break or cultural gap in the areas of Harappa, Jalilpur and other excavated sites noticed in Hakra/Sarasvati valley.

The C 14 dates from Bhirrana agree with the accepted known chronology of the Harappan Civilization starting from Early Harappan to Late Harappa. But for the first time, on the basis of radiometric dates from Bhirrana the cultural remains of pre-Early Harappan horizon go back to the time bracket ranging in date between c. 7380 – 6201 BCE. However this early time bracket was not noticed earlier from any other excavated Harappan site from this region.

In northern Pakistan except at Mehrgarh, the cultural stages are not so demarcated in Gomal plains and mesolithic hunter-gatherers occupying stabilized sand dunes were found adopting to a neolithic way of life amidst a cluster of smaller settlements as revealed from the borders of southern Sindh, North Gujarat and south-eastern Rajasthan. These “Pre-Harappan settlers” in the long run gave rise to primary urbanization till the early/mature Harappans did not completely occupy the scene by constructing monumental buildings, grid pattern planning, granaries, script, various crafts and ritual at centres like Harappa, Mohenjodaro, Kalibangan and also Dholavira and Lothal while establishing maritime trade contacts.

The region of Haryana has so far provided the earliest radiometric dates in

comparison to other parts of Harappan Civilization such as the upper reaches of Ravi and also the lower part of Indus region, although it has still several cultural stages to fill up. Thus the ‘Lost’ Sarasvati/Hakra valley laid a new foundation for urban life and set in motion one way or another, the status of Hakra-Sarasvati region as the cradle of Indian civilisation.

ACKNOWLEDGEMENT

I am indebted to many individual scholars and institutions for extending their guidance and help. When Shri LS Rao was excavating Bhirrana, he brought the excavated material to Delhi for opinion. On examination, it was found that the material was quite different in comparison to early Harappan fabrics, but it was beyond my expectation that the antiquity of the site on the basis of radiometric dates will go back to the middle of 8th millennium BCE. I am thankful to Director General of the Archaeological Survey of India who allowed me to visit Nagpur with Dr. BR Mani for the examination of the material personally. The staff and Dr. Nandini Sahu, Superintending Archaeologist of the Excavation Branch I, Nagpur extended all help. Dr. Prabhash Sahu who was also attached with the excavations explained the position of antiquities and other material in relation to stratigraphic position at Bhirrana. Special thanks are due to Dr. BR Mani and Dr. SK Mitra who extended their support for the study of this material. Thanks to Dr. Amrendra Nath, for showing me the excavated material of Bhirrana. I am also



grateful to the Archaeological Survey of India for supplying me the radio-metric dates of Bhirrana, Rakhigarhi and other sites. Thanks are also due to Dr. J. Mark Kenoyer who invited me to visit Pakistan and gave me an opportunity to visit and study the excavated material housed at Harappa and Mohenjo-daro. Prof. Farzand Masih of the Department of Archaeology, Punjab University, Lahore arranged an exhibition of the explored early Harappan material from Cholistan for our study. The authorities of the National Museum, Karachi

also extended their help in showing us the Harappan material especially Harappan Priest. Dr. Vasant Shinde, Pune and Dr. P. Ajithprasad, Vadodara deserve my special thank for providing details of their works carried out in north Gujarat and south-east Rajasthan. Shri Bharat Singh of the Indian Archaeological Society extended his support in the completion of this article without any hesitation. I also extend my grateful thanks to the scholars whose illustrations have been utilized for the publication in this article.

References

- Ajithprasad, P. 2011. Chalcolithic Culture Patterns and Early Harappan Interaction in Gujarat, in *Cultural Relations between the Indus and The Iranian Plateau during the Third Millennium BCE* (Toshike Osada and Mechael Witzel Eds), pp. 11-40. Cambridge: Dept. of South Asian Studies Harvard University.
- Ajithprasad, P. and V.H. Sonawane 2011. The Harappa Culture in North Gujarat. a Regional Paradigm, in *Linguistics, Archaeology and the Human Past* (Toshiki Osada and Hitoshi Endo Eds.), pp. 223-266. Kyoto: Indus Project of the Research Institute for Humanity and Nature Kyoto, Japan.
- Ali, Ihsan and Peter Eltsov 2009. The Archaeology of Gomal Valley, North West Frontier Province, Pakistan New hypotheses about the Earliest South Asian Civilization in the light of Recent Discoveries, *Pakistan Heritage* 1: 1-13.
- Bhan, Suraj 1971-72. Siswal: A Pre-Harappan Site on the Drishadvati Valley, *Puratattva* 5: 44-46.
- Bisht, R.S. 1982. Excavations at Banwali: 1974-77, in *Harappan civilization: A Contemporary Perspective* (G.L. Possehl Ed.), pp. 113-24. Delhi: Oxford and IBH and the American Institute of Indian Studies.
- Burrard, S.G. and H.H. Hayden 1907-1908. A sketch of the Geography and Geology of the Himalaya Mountains and Tibet. Calcutta: Govt. of India Press.
- Casal. Jean-Marie 1964. Fresh digging at Amri, *Pakistan Archaeology* 1: 57-65.
- Dani, A.H. 1970-71. Excavation in the Gomal Valley, *Ancient Pakistan* 5: 1-177.
- Dikshit, K.N. 1977. Distribution and Relationship of Protohistoric sites along Old River channels of the Ghaggar System, in *Ecology and Archaeology of Western India* (D.P. Agarwal and B.M. Pande Eds.), pp. 61-66. New Delhi: concept Publishing Company.
- Dikshit, K.N. 1979. Old Channels of Ghaggar in Rajasthan – revisited, *Man and Environment* No.3, 105-106.
- Dikshit, K.N. 1980. A Critical Review of pre-Harappan Cultures in Indo-Pak Sub-Continent, *Man and Environment* No. 4, 32-43.
- Dikshit, K. N. 1984a. The Sothi complex: Old Records and Fresh Observations, in *Frontiers of the Indus civilization: Sir Mortimer Wheeler Commemoration Volume* (B.B. Lal and S.P. Gupta Eds.), pp. 531-537. Delhi: Books and Books,.



- Dikshit, K.N. 1984b. The Pre-Harappan culture of Rajasthan, *Bharati* 2: 55-70.
- Dikshit, K.N. 2010. The 'Lost' Saraswati: A Prelude to Urbanization in Ancient Punjab, *Journal of Department of Archaeology University of Punjab, Lahore*, Vol. I:19-35.
- Dikshit, K.N. 2012. *The 'Lost' Saraswati river: The Cradle of Indian Civilization*. International Conference on "Archaeology and Cultural Heritage in Pakistan and adjacent regions" Islamabad. (in the press)
- Dikshit, K.N. and B.R.Mani 2012. Indian Civilization evolved in the 8th Millennium BCE in the Plains of 'Lost' River Saraswati, *Puratattva* No. 42, New Delhi: 265- 269.
- Dikshit, K.N. 2012. *The 'Lost' Saraswati: A Cradle of Indian Civilization*, *Puratan, Journal of Directorate of Archaeology, Archives and Museum, Madhya Pradesh, Bhopal*, Vol. 16: 5-19.
- Durrani, F.A. 1988. Excavations in the Gomul valley – Rehman Dheri Excavations, *Ancient Pakistan* Vol. 6: 1-232.
- Enzel, Y., L.L. Ely, S. Mishra, R. Ramesh, R. Amit, B. Lazar, S. N. Rajaguru, Y. R. Baker and A. Sandler 1999. High-Resolution Holocene Environmental changes in the Thar Desert, Northwestern India, *Science* 284:125-128.
- Field, H. 1959. *An Anthropological reconnaissance in West Pakistan, 1955*. Papers of the Peabody Museum of Archaeology and Ethnology, Harvard University, Vol 3. Cambridge: Peabody Museum.
- Flam. L. 1996. Explorations in the Sindh and the Sindh Archaeological Project, in *Exploration in Art and Archaeology of South Asia: Essays Dedicated to N.G. Majumdar*, (D. Mitra Ed.),pp. 33-51. Calcutta: Government of West Bengal.
- Ghosh. A 1952. The Rajputana Deserts, its Archaeological Aspect, *Bulletin of the Council of National Institute of Science of India* 1: 37-42
- Gupta, S.P. 1996. *The Indus-Saraswati Civilization, Origins, Problems and Issues*, Delhi.
- Halim, Muhammad Abdul 1970-71. Excavation at Sarai Khola-I, *Pakistan Archaeology* 7:23-89.
- Halim, Muhammad Abdul 1972. Excavation at Sarai Khola-II, *Pakistan Archaeology* 8:1-112.
- Indian Archaeology 1960-61: A Review, New Delhi:31-32.
- Jarrige, C., J.F. Jarrige, R. H. Meadow and G. Quivron 1995. *Mehrgarh Field Reports 1974-85*. From *Neolithic Times to the Indus Civilization*. Karachi: The Department of Culture and Tourism, Government of Sindh.
- Kenoyer, J. and R. Meadow 2000. The Ravi Phase: A New Cultural Manifestation at Harappa, in *South Asian Archaeology 1997* (M. Taddei and G. De Marco Eds.),pp. 55-76. Rome/Naples: Istituto Universitario Orientale.
- Kenoyer, J.M. 2011. Changing Perspectives of the Indus Civilization: New Discoveries and Challenges, *Puratattva* 41: 7-18.
- Kesarwani, Arun 2002. *Excavation at Balu, Distt. Kaithal, Haryana*. Kurukshetra: Nermal Book Agency.
- Khan, F.A. 1965. Excavation at Kot Diji, *Pakistan Archaeology* 2: 13-85.
- Khatri, J.S. and M. Acharya 1995. Kunal: A New Indus Saraswati Site, *Puratattva* 25: 84-86.
- Lal, B.B. 2009. *How Deep are the Roots of Indian Civilization? Archaeology Answers*. New Delhi: Aryan Books International.
- Lal. B.B., B.K. Thapar, J.P. Joshi, and Madhu Bala 2003. *Excavations at Kalibangan: the Early Harappans (1960-1969)*. New Delhi: Archaeological Survey of India. (Memoirs of the Archaeological Survey of India, No. 98)
- Mallah, Q.H. 2008. Recent Archaeological discoveries in Sindh Pakistan, in *Linguistics, Archaeology and Human Past* (Toshiki Osada and Ankinori Uesugi Eds.),pp. 27-76. Kyoto: Indus Project, Research Institute for Humanity and Nature, Kyoto, Japan.
- Misra, V.N. 1973. Bagor - A Late Mesolithic settlement in North-west India, *World Archaeology* V (1): 92-100.
- Misra. V.N. and S.N. Rajaguru 1975. Some Aspects of Quaternary Environment and Early Man in Western India, *Proceedings of Problems of Deserts in India*. Jaipur.
- Mughal, M.R. 1972. Excavation at Jalilpur, *Pakistan Archaeology* 8: 157-24.
- Mughal. M.R. 1974. New evidence of early Harappan Culture from Jalilpur, *Pakistan Archaeology* 27 (2): 106-13.
- Mughal, M.R. 1981. New Archaeological Evidence from Bhawalpur, in *Indus Civilization: New Perspective* (A.H. Dani Ed.), pp.33-41. Islamabad: Centre for the Study of the Civilizations of Central Asia, Quaid-e-Azam University.



- Mughal, M.R. 1997. *Ancient Cholistan*. Lahore.
- Nath, A. 1997-98. Rakhigarhi: A Harappan Metropolis in the Sarasvati - Drishadvati Divide, *Puratattva* 28: 39-49.
- Nath, A. 1998-99. Further Excavation at Rakhigarhi, *Puratattva* 29: 46-49.
- Pal, Yash, B. Sahai, R.K. Sood. And D.P. Agrawal 1984. Remote Sensing of the 'Lost' Saraswati River, in *Frontiers of the Indus Civilization: Sir. Nortimer Wheeler Commemoration Volume* (B.B. Lal and S.P. Gupta Eds.),pp. 491-97. New Delhi: Books and Books.
- Possehl, G.L 1999. *Indus Age, The Beginnings*. New Delhi: Oxford and IBH Publishing.
- Possehl, G.L. 2010. What's in a Name?: The Indus civilisation, onomastics and the Rules of Science, in *On the Track of Uncovering a Civilization: A Volume in Honor of the 80th – anniversary of Victor Sarianidi, Transactions of the Margiana Archaeological Expedition, Sankt-Petersburg, Aletheia*, 120-128.
- Puri, V.K.M. 2001. Origin and Course of Vedic Saraswati River in Himalaya – Its Secular Desiccation Episodes as Deciphered from Palaeo-Glaciation and Geomorphological Signatures, *Proceedings of the Symposium on Snow, Ice and Glaciers*. Geological Survey of India Special Publications, Vol.53: 175-191
- Rao, L.S., N.B. Sahu, Prabash Sahu, U.A. Shastri and Samir Diwan 2003-04. Unearthing Harappan Settlement at Bhiranna 2003-04. *Puratattva* 34: 20-24, New Light on the Excavation of the Harappan Settlement at Bhirrana, *Puratattva* 35: 60-75 and Bhirrana Excavation – 2005-06, *Puratattva* 36: 45-49.
- Sant U., T.J. Baidya, N.G. Nikoshey, N.K. Sinha, S. Nayan, J.K. Tiwari and A. Arif Baror 2004-05. A New Harappan Site in Ghaggar Valley – A Preliminary Report, *Puratattva* 35: 50-59.
- Sharma, D.V., K.C. Nauriyal, V.N. Prabhakar and Vishnukant 2004. Sanauli: A Late Harappan Burial Site in the Yamuna-Hindon Doab, *Puratattva* 34: 35-44
- Shinde, V. 1992. Excavations at Padri-1990-91: a Preliminary Report, *Man and Environment* 17 (1): 79-86.
- Shinde, V., T. Osada, M.M. Sharma, A. Uesugi, T. Uno, H. Maemoku, P. Shirwalkar, S.S. Deshpande, A. Kurkarni, A.Sarkar, V. Rao and v. Dangi Mar 2008. Exploration in the Ghaggar basin and Excavations at Girawad, Farmana (Rohtak District) and Mitathal (Bhiwani District). Haryana, India, in *Linguistics, Archaeology and the Human Past. Occasional Paper 3. Indus Project* (To. Osada and A. Uesugi Eds.),pp. 77-158. Kyoto: Research Institute for Humanity and Nature.
- Shweta Sinha Deshpande and Vasant Shinde 2006. Development of Urbanization in the Mewar Region of Rajasthan, *Ancient Asia* 1: 103-122.
- Singh, G. 1971. The Indus Valley culture seen in the context of Post-Glacial climate and Ecological Studies in Northwestern India, *Archaeology and Physical Anthropology in Oceania* 6 (2): 177-189
- Stein, Auriel 1942. A Survey of Ancient Sites along the 'Lost' Saraswati River, *The Geographical Journal* 99 (4): 173-82
- Tessitori, L.P. 1917-18. In *Annual Report*, 22-23. New Delhi, Archaeological Survey of India.
- Tripathi, J.K., B. Book, V. Rajamani and A. Eisenhauer 2004. Is River Ghaggar, Saraswati? Geochemical Constraints, *Current Science* 87 (8): 1141-1145.
- Trivedi, P.K. 2009. *Excavations at Tarkhanewala-Dera and Chak* 86 (2003-04). New Delhi, Archaeological Survey of India.
- Wadia, D.N. 1994. *Geology of India*. New Delhi: Tata Mcgraw-Hill- Publishing Co.
- Wheeler, R.E.M. 1947. Harappa 1946: The Defences and Cemetery R-37, *Ancient India* 3: 91.
- Wilhelmy, Herbert 1969. Urstromtal am ostrand der Indusebene Under Sarasvati- Problem, in (*Karlheing Kaiser* ed) *Glazialmorphologie Glacial Morphologie. Zeitschrift für Geomorphologie Supplementband* 8: 76-93.





K.N. Dikshit, Plate 4: Harappa: Terracotta wheel from Ravi phase (courtesy: J.M. Kenoyer)

K.N. Dikshit, Plate 5: Jalilpur: Hakra Mud Appliqué Ware (courtesy: M.R. Mughal)



K.N. Dikshit, Plate 6: Jalilpur – I & II Pottery painted with white and black on red, black and brown on red or white slip (courtesy: M.R. Mughal)



K.N. Dikshit, Plate 7: Gumla : Painted sherds





K.N. Dikshit, Plate 8: Rehman Dheri: Painted pottery fish showing lion and ass, period II; motifs (courtesy: Durrani)Hathala birds; Gumla: horned deity from period III. (courtesy: Dani)



K.N. Dikshit, Plate 9: Main archaeological sites in Sindh (courtesy: Qasid H. Mallah)

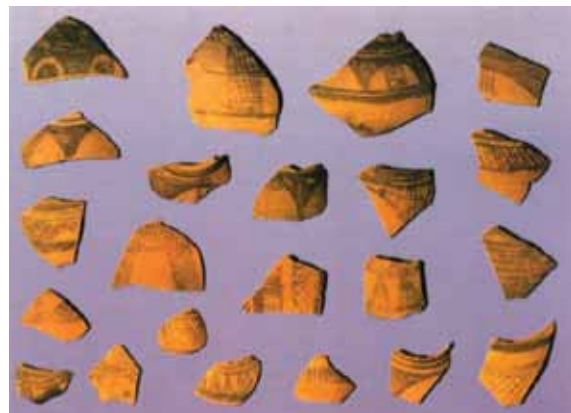

K.N. Dikshit, Plate 10: Early Harappan pottery from Kalibangan

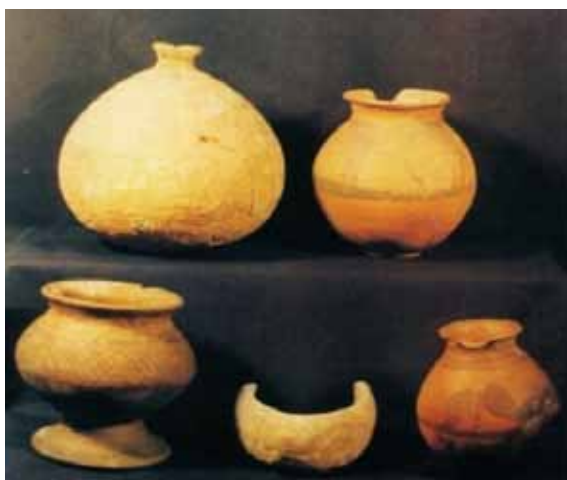

K.N. Dikshit, Plate 11: Early Harappan pottery from Kalibangan



K.N. Dikshit, Plate 12: Early Harappan pottery from Kalibangan





K.N. Dikshit, Plate 13: Early Harappan pottery from Kalibangan



K.N. Dikshit, Plate 14,15: Early Harappan pottery from Kalibangan (courtesy: BB Lal) The Kalibangan-I has been compared with Amri-IC-IIB (Casal 1964), Gumla II-III (Dani 1970-71), pre-defence Harappa (Wheeler 1947, Kenoyer and Meadow 2000), Kot Diji-I, Jalilpur-II (Mughal 1974) and Sarai Khola II (Halim 1972). However, later on this phase of pre-Harappa was accepted as the 'Early Harappans' as a few of the traits of the Mature Harappan such as brick sizes in the ratio of 1:2:4 were present in this level.



K.N. Dikshit, Plate 16: Kunal : Early Harappan Pottery, painted with two colours: black outline and white in filling





K.N. Dikshit, Plate: 17: Kunal: A pot (courtesy: J.S. Khatri and M. Acharya)



K.N. Dikshit, Plate 18: General view of Dwelling-pit Complex





K.N. Dikshit, Plate 19: pre-
Early Harappan wares: mud
appliqué designs – Hakra ware
(dominant fabric in lowest
levels of dwelling-pits IA)



K.N. Dikshit, Plate 20: Deep
incised ware from dwelling
pits IA



K.N. Dikshit, Plate 21: Light
incised ware IA-IB





K.N. Dikshit, Plate 22: Black burnished ware IA-IB



K.N. Dikshit, Plate 23: Bichrome ware IA-IB



K.N. Dikshit, Plate 24: Tan/Chocolate ware IA-IB





K.N. Dikshit, Plate 25: Incised Pottery (Internally) (Pd. IIA)



K.N. Dikshit, Plate 26: Rusticated Pottery (Pd. IIA)



K.N. Dikshit, Plate 27: Buff and Mixed Ware (Pd. IIA - Grey Ware)





K.N. Dikshit, Plate 28: Buff and Mixed Pottery (Pd. IIA -Buff Ware)



K.N. Dikshit, Plate 29: Black on Red Ware (Pd. IIA)



K.N. Dikshit, Plate 30: Bichrome Ware (Pd. IIA)





K.N. Dikshit, Plate 31: Bhirrana – Antiquities from period IA-IB (courtesy: L.S. Rao)



K.N. Dikshit, Plate 32: Baror (courtesy: Archaeological Survey of India (1:4))





K.N. Dikshit, Plate 33: Girawad, Mud Applique ware Plate



K.N. Dikshit, 34: Girawad, Chocolate slipped and Red wares



K.N. Dikshit, Plate 35: Tan Slipped and Bichrome wares Farmana





K.N. Dikshit, Plate 36: Farmana: Pottery from pre-Early Harappan levels (1:4) (Courtesy Shinde)



K.N. Dikshit, Plate 37: Farmana: Pottery from pre-Early Harappan levels (Courtesy Shinde)



K.N. Dikshit, Plate 38: Bagor :Mesolithic pottery (courtesy: VN Misra)

