

# **The Belgammel Ram, a Hellenistic-Roman Bronze *Proembolion* Found off the Coast of Libya: test analysis of function, date and metallurgy, with a digital reference archive**

Jonathan R. Adams

*Department of Archaeology, School of Humanities, University of Southampton, SO17 1BF, UK*

Annita Antoniadou and Chistopher O. Hunt

*School of Geography, Archaeology and Palaeoecology, Queen's University Belfast, BT7 1NN, UK*

Paul Bennett

*Canterbury Trust, 92a Broad St, Canterbury, Kent, CT1 2LU, UK*

Ian W. Croudace, Rex N. Taylor and Richard B. Pearce

*Ocean and Earth Science, University of Southampton National Oceanography Centre, SO14 3ZH, UK*

Graeme P. Earl

*Archaeological Computing Research Group, University of Southampton, SO17 1BF, UK*

Nicholas C. Flemming

*National Oceanography Centre, Southampton, SO14 3ZH, UK*

John Moggeridge and Timothy Whiteside

*Department of Non-Destructive Evaluation, Atomic Weapons Establishment, Aldermaston, Berkshire, RG7 4PR, UK*

Kenneth Oliver

*14 Treeside Rd, Shirley, Southampton, SO15 5FZ, UK*

Anthony J. Parker

*School of Arts, University of Bristol, BS8 1UU, UK (retired)*

The Belgammel Ram was found off the coast of Libya in 1964, and examined during 2008–9. The following techniques were used: surface non-contact digitizing using a laser scanner, reflectance transformation imaging using polynomial texture mapping and hemi-spherical harmonics, digital photogrammetry with dense surface modelling, structured light optical scanning, and X-ray fluorescence analysis. For internal structure the ram was examined by X-radiography and 3-D X-ray tomography. Metallurgical composition was studied by micro-drilling and subjecting the samples to scanning electron microscope X-ray micro-analysis, micro X-ray fluorescence and X-ray backscatter. The lead isotope composition was analysed.

The alloy has average percentage composition Cu = 86.9, Sn = 6.3, Pb = 6.6, and Zn = < 0.10. The Belgammel Ram is probably a Hellenistic-Roman *proembolion* from a small military vessel or *tesseraria*. The archived data are at the Faculty of Engineering and Environment, Engineering Sciences, Material Data Centre, University of Southampton (muvis@soton.ac.uk).

© 2012 The Authors

*Key words:* Bronze ram, Hellenistic-Roman, *proembolion*, Libya, Fitzwilliam, Belgammel.

The provenance and name of the Belgammel Ram, previously known as the Fitzwilliam Ram, require explanation before we describe its probable function, composition and manufacture. In 1964 a group of British recreational divers found the ram at a depth of 25 m off the coast of Libya near Tobruk (Figs 1 and 2). The location was determined by the point of access to the water from a beach known as Waddi Belgammel. There was no archaeological authority in Tobruk to whom this find could be reported, and one of the finders brought the ram back

to Britain as a souvenir. In 1968 the ram was loaned to the Fitzwilliam Museum, University of Cambridge, and a description published by Nicholls (1971) without an accurate find-location.

The original correspondence related to this transfer is on record and has been checked by some of the present authors (NCF, PB and KO). The ram was taken back into private ownership in 1991, and in 2004 was bequeathed to one of us (KO), the last surviving member of the group who discovered the ram in 1964. KO decided to return the ram to Libya, and this was arranged by PB, through the good offices of the Society for Libyan Studies, and with the written agreement of the Fitzwilliam Museum. The ram was returned to the Museum of Libya in Tripoli in May 2010, together with a technical brochure containing the laboratory reports on which the present paper is based. A more detailed description of the management and protocol of the return will be published in the journal of the Society for Libyan Studies. The linear dimensions and appearance of the ram were published by Pridemore (1996: 74–98). Given its provenance and its present curated position in the Museum of Libya, Tripoli, it is appropriate that the ram should be known by its place of discovery, as the ‘Belgammel Ram’. Pridemore (1996: 78) states that the designation of the ram should be revised when its place of discovery is established beyond doubt, and this has now been done.

The Belgammel Ram has been previously described briefly by Nicholls (1971) and Pridemore (1996: 74–98)

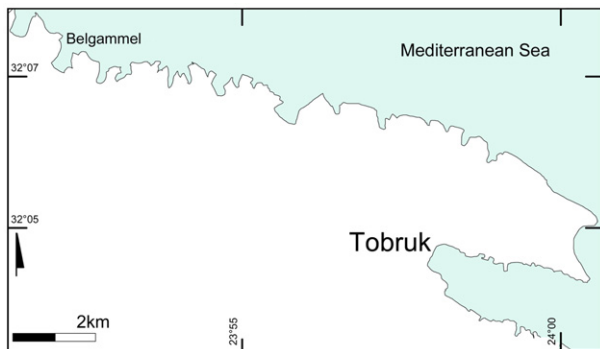

Figure 1. The coast of Libya near Tobruk. Wadi Belgammel does correlate quite well with the printed maps from the 1940s, and KO has confirmed the accurate details of the waddi on magnified versions of a Google Earth image. (After a Google Earth image)

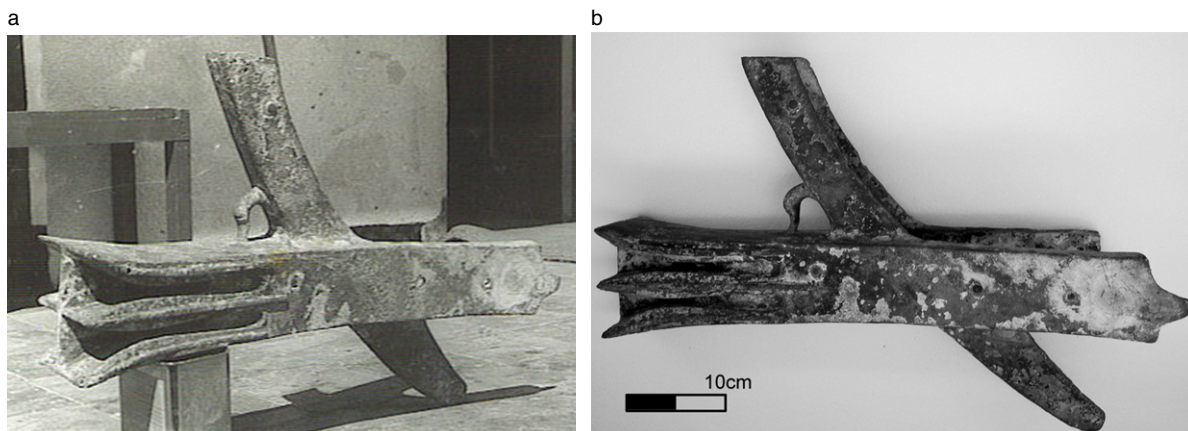

Figure 2. a) The Belgammel Ram photographed in Libya in 1964. The photographer is unidentified but was one of the recovery team. From the shadow, the sun is very high overhead, and the picture must have been taken in Libya. Note the patterns of corrosion and discolouration in comparison with Fig. 2b; b) High resolution photographic image of the ram, 2009. The main outlines of colour boundaries of the patina and corrosion patches look the same as in 1964. (AWE, Crown Copyright)

but no laboratory studies of its composition had been carried out before the research described here. We hope that the information provided, and the more detailed X-ray, chemical and metallurgical details published by Croudace *et al.* (forthcoming) will assist scholars in the rapidly widening study and understanding of classical naval warfare and shipbuilding. The data obtained from the use of a wide range of techniques have not yet been fully analysed or exploited to extract the maximum amount of information, and scholars are encouraged to request the original data if they wish to pursue this analysis further.

The objective of this paper is firstly to draw attention to the existence of the Belgammel Ram and its provenance, and secondly to provide access to a wide range of data which have the potential to reveal more about its origin, manufacture and function. Those wishing to access all or part of the archived data should contact the Faculty of Engineering and Environment, Engineering Sciences, Material Data Centre, University of Southampton (muvis@soton.ac.uk).

In the near future it should be possible to compare and examine the metallurgy, casting methods, and functions of a variety of rams which have been recovered from the Mediterranean. Descriptions of the Athlit Ram, which is larger than the Belgammel Ram, have been published by Linder and Ramon (1981), Casson and Steffy (1991), Pridemore (1996) and Oron (2006). Oron's MA dissertation (2001) describes in detail the techniques of lost-wax casting and the use of chaplets to support the core within the mould. While the laboratory study of the Belgammel Ram was being conducted in Britain, nine further rams were discovered off the Egadi Islands, western Sicily, bringing the total of Egadi Rams to 10 and the report on these is being prepared by Jeffrey Royal and Sebastiano Tusa (pers. comm., and see the RPM Nautical Foundation website, Tusa and Buccellato, 2008; Buccellato and Tusa 2009; Tusa and Buccellato, 2010). A further example has been found by a snorkeller off Capo Rasocolmo, Sicily in 2008 (Caruso *et al.*, 2011; Buccellato and Tusa, this volume).

For those seeking a general introduction to the importance of the ram in ancient warfare in the Classical period a recent book by Hale (2009) provides a general overview of tactics and strategy. The most recent study of bronze rams in the Hellenistic navies is provided by Murray (2011: 49, Table 2.1, 52, Fig. 2.12).

Three of the authors (PB, NCF and KO) have observed the ship-monument at Cyrene, Libya, and compared the Belgammel Ram with the representation of the upper and lower rams on that monument. The Cyrene monument has been described and published by Ermeti (1981). While the model is visually satisfying, the components have been assembled from carved stones which are not directly juxtaposed and do not have necessarily contacting shaped surfaces. Thus the representation of a *proembolion* is useful and illustrative, but not absolute proof of the relative positions and sizes of multiple rams.

## Shape and function

The Belgammel Ram weighs 19.7 kg, and measures 441 mm high and 640 mm long (Fig. 3). According to Pridemore (1996: 79) there is considerable metal loss due to bronze disease, but the surface of the ram has appeared stable to all those who have worked with it for the past 45 years, and the Fitzwilliam Museum deemed it to be stable (Pridemore, 1996: 78). For a detailed description of the dimensions of the cowl, ram-head, and cowl-piece see Pridemore (1996). The concern about the stability of the surface and the risk of bronze disease is justified, but Figure 2a, taken in 1964, and Figure 2b, compiled in 2009, show no obvious differences in texture or outline even in the area of sharpest detail and decoration. The surface X-ray fluorescence chemical analysis (see below) shows a relative loss of copper compared with the microdrill samples, and thus a comparative enrichment of lead and tin on the surface compared with the interior, but this process appears to have reached a stable endpoint, with no further deterioration after removal from the sea.

Pridemore (1996) discusses previous interpretations of the function of the Belgammel Ram, and concludes that it is a secondary ram or *proembolion*. There is an important point of fact to be corrected in regard to both the report by Nicholls (1971) and Pridemore's dissertation (1996: 94–98). Both publications describe late Roman amphora fragments which were presented to the Fitzwilliam Museum at the same time as the ram, and these fragments have caused confusion regarding the probable date of the ram itself. KO states that the amphora fragments were recovered near the island of Derna, not adjacent to the ram, but were mistakenly assumed by the Fitzwilliam Museum to have been found with the ram. Due to the apparent conflict between the probable date of the ram and the pottery, Pridemore (1996: 98) correctly concludes that the ram and the amphoras came from different wrecks.

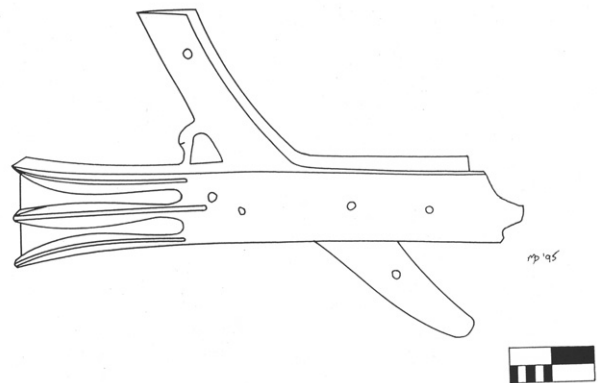

Figure 3. Drawing of the ram from the thesis by Pridemore (1996: fig. 26), scale is 10cm. (Reproduced by permission)



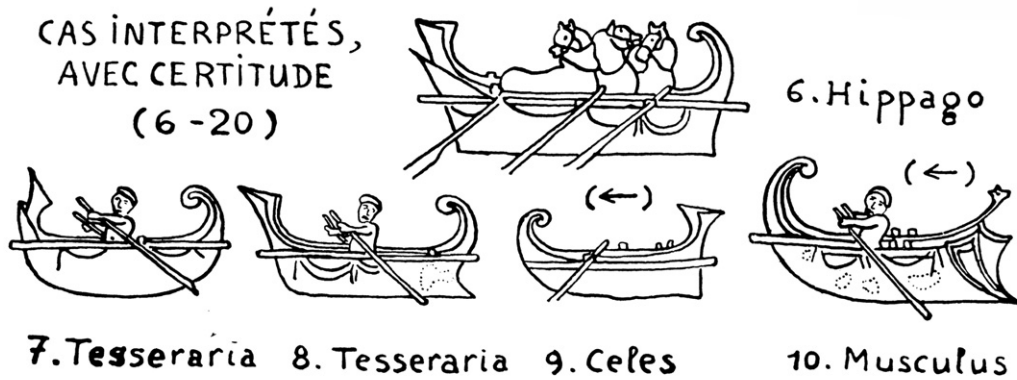

Figure 4. Number 8 in this drawing is a *tesseraria*, or small military vessel. The bow of the vessel is to the right, and shows the double curve with the upper ram on the convex section. The drawing is from Casson (1995: no. 137). (Reproduced by permission)

The date for the ram must therefore be established on the basis of internal consistency, without reference to the pottery.

The Egadi Rams are closer in design to the Athlit Ram than the Belgammel and therefore do not influence the discussion of the design of the Belgammel Ram, although they do of course add greatly to the repertoire of rams now available for study, and hence to our understanding of ancient naval warfare. Previous studies of waterline ram typology based on the Athlit Ram and records of battles such as the battle of Actium and the associated monuments have been published by Murray (1985, 1988, 1991 and 1996) and Murray and Petsas (1989).

The piece from Belgammel is a *proembolion* (Greek προεμβόλιον), a ‘fore-ram’ (Casson, 1995:85), ‘upper ram’ (Morrison, 1996), or ‘subsidiary ram’ (Nicholls, 1971: 85). ‘Half-way up the stempost,’ writes Casson (1995: 85) ‘the point where the waling pieces on port and starboard came together was capped by a subsidiary spur (*proembolion*).’ Illustrations, for example in Morrison (1996: 214–53), show that the *proembolion* could be a simple box-shape, or be formed decoratively as an animal-head or other device, or (as here) be in the shape of a warship’s ram. Underwater finds of a wolf’s head (from Genoa) and a boar’s head (from Fos-sur-Mer) are identified as warship *proembolia* by Gianfrotta and Pomey (1981: 292).

The *proembolion* was evidently a distinctive and characteristic item of Hellenistic and Roman oared ships, and it appears even in abbreviated sketches (Figs 4–6). Obviously it would cause further damage to the upperworks of any ship which was rammed by the main ram (*embolos*), but one assumes that its primary function was to protect the open-grain ends of the wales, and to form part of the bronze decoration which was an important feature of these ships, especially at the bow. The Belgammel *proembolion* is compared by Nicholls (1971: 85) with representations of rams (*emboloi*) from the Hellenistic period, the 3rd to 1st



Figure 5. Coin of Demetrius Poliorcetes, a Macedonian general about 300 BC. From the British Museum. Note upper ram, and the convex nature of the upper part of the stem. The Belgammel Ram was mounted on a small vessel where the *proembolion* was on the convex portion. (Reproduced by permission)

centuries BC, but from other iconographic and archaeological comparisons the Belgammel piece sits more easily in a late Hellenistic or early Roman Empire context, from the 2nd century BC to the 1st or 2nd century AD.

In general terms the Belgammel piece is comparable with the stempost element (*ruota di proa*) from the Lake Nemi Ship 1, probably dating from the first part of the 1st century AD (Ucelli, 1950: 148, fig. 151). This is a U-shaped bronze casting of which three adjacent sections are preserved. There is no decoration, and it seems to have been secured to the wooden stempost with the aid of tangs which project from the after edges of the bronze. The published drawing suggests that it



Figure 6. Painting from a fresco in Naples/Pompeii, showing the bow of two warships with waterline rams and smaller, upper rams with a similar slightly impressionistic representation of the bladed structure. The upper ram is at the level of the outrigger for the oars, and is located over the ends of the wales. (K. Oliver)

may have been hammered on to the stempost. The Belgammel piece, by contrast, was firmly attached to stempost and wales by bolts or rivets: this may have been necessary given its overhanging profile, or it may indicate a more workmanlike technique.

The S-shaped lateral profile of the Nemi bronze confirms the marked sinuosity of Roman warships' stempost profile, as seen in iconography, and helps to confirm the interpretation of the Belgammel piece. We have, however, failed to find (in Ben-Eli, 1975 or Morrison, 1996) an exact iconographic parallel in warship representations for the overhanging, convex profile of the Belgammel stempost. The best parallel is ship no. 8, 'tesseraria', on the 3rd- or 4th-century-AD Althiburus mosaic (Casson, 1995: 135, ill. 137) (Fig. 4). The *tesseraria* was probably a small military oared ship, used to carry messages round a fleet; this provides a good hypothesis for the nature of the Belgammel ship. The convex stempost profile is also characteristic of Roman Empire merchant ships (as for example Casson, 1995: ill. 135), whether oared or sail-powered, but none has a decorative *proembolion*, let alone a trident, so a small warship seems the best identification. The Althiburus mosaic provides no guarantee of date.

The trident-shaped ram is a commonplace, but the Belgammel piece has a distinctive feature: the swan- or duck-shaped ring, cast into it between stempost and projection. Water-birds are a fairly frequent motif in Graeco-Roman art, sometimes symbolic; they were also, of course, often used to decorate ships. A tomb relief of c.AD 100 in the British Museum (Morrison, 1996: 247, no. 44) shows a swan riding the bow-wave of

a warship under sail and oars, which, if modelled in bronze on an actual ship's forefoot, would have been an impressive device. Many Greek or Roman ships bore a prominent sternpost ornament, the *chēniskos*, in the shape of a goose-head (presumably to simulate, together with the mainsail, the 'goose-wing' effect of the ship running downwind, away from the observer); this would often be of bronze, and might be gilded (Casson, 1995: 347–8). However, the small, waterbird-shaped ring on the Belgammel *proembolion* has not been found in iconography. As Nicholls says (1971: 85), it would be a natural fitting to take a rope, such as a painter.

Among the finds from the Mahdia wreck (Tunisia, 1st century BC) are two little bronze ducks (55 mm high), shown as if swimming. They were originally attached to the upper surface of a timber, and so could have appeared to swim, if they were mounted near a ship's waterline. Each has a cast strut left in place between breast and bill, forming a ring (or perhaps the armature of a ring): 'Could they have been used to hold and fasten narrow leather thongs, rope, or fillets to secure something in place?' writes Barr-Sharrar (1994: 568–9). There are other nautical decorative items from Mahdia, but it is not certain whether they belonged to the sunken ship, or came from trophies or furniture on land. A group of bronzes which could have been ship's equipment comprises four 160-mm-high cast-bronze fittings, forming a hook or cleat in the shape of a swan's head and neck, which merges into a miniature steering-oar. Petrovsky (1994: 675–6, 694–5) considers these objects to have been handles from a bronze

**Table 1.** Sample details and  $2\sigma$  calibration for radiocarbon dating of the wood from the Belgammel Ram. The  $^{14}\text{C}$  age is the raw radiocarbon age before calibration. The AMS  $\delta^{13}\text{C}$  figure is generated along with the raw radiocarbon age in the AMS system. The probability figures in the last column refer to the likelihood that the date will fall in the age-range in the previous column. Thus, for Belgammel B, there is a likelihood of 76.5% that the date will fall between 329 and 203 BC, and a 23.5% likelihood that it will fall between 385 and 339 BC

Lab. ID	Sample ID	Sample type	$^{14}\text{C}$ Age	$\pm$	AMS $\delta^{13}\text{C}$	Calibrated date BC $2\sigma$	Probability
UBA-10244	Belgammel A	Sediment	2534	19	-28	792–747	0.431
						688–665	0.236
						644–587	0.257
						584–554	0.075
UBA-10245	Belgammel B	Wood	2227	31	-29.7	385–339	0.235
						329–203	0.765

vessel, but admits to finding no close parallel. The steering-oar element suggests a nautical context, and there are other bronze waterbird finds from marine contexts, in one case specifically from an oared ship: these are considered next, and show that the Mahdia cleats originated as ship fittings, whether of the sunken ship herself or deriving from another ship or a trophy.

Two bronze waterbird hooks or cleats, of different types, fragmentary but originally similar to the Mahdia examples, come from the wreck *Saintes Maries 4*, France: the assemblage is known only from fishermen’s finds, so it is not certain that these items were part of the ship, which is thought to have sunk in the 1st or 2nd century AD (DRASSM, 2005: 60–64). Another waterbird-shaped hook, with a shorter stem, was found between Haifa and Atlit (Israel): here two of the fixing nails are still in place, so it probably came from a wrecked ship (Beltrame, 2002: 15–16). Several others, similar to the Israeli find, were certainly fittings aboard a small oared ship which sank off Capo Rasocolmo, Sicily, c.36 BC; together with bronze bolts or pins, these lay along the outline of the ship’s waist, though the wooden hull has disappeared (Parker, 1992: 121–2, no. 247). From this it emerges that bronze cleats or rings, in the form of a waterbird, were a commonplace fitting aboard oared galleys of the period c.100 BC to AD 100. The ring which is part of the Belgammel *pro-embolion*, though apparently unique, belongs to this genre, and thus tends to reinforce its date which, from iconographic comparisons, seems to be of late Hellenistic or early Roman Empire.

## Analysis and dating of samples

### Methods and materials

Two samples were selected from the material found inside the Belgammel Ram. These consisted of: Belgammel Sample A, light-grey sandy slightly organic silt containing small fragments of charcoal, which was recovered adhering between wood and metal plates; and Belgammel Sample B, a very dark-grey to black dense pyritic material regarded by the excavators as wood, found originally inside the ram.

**Table 2.** Palynofacies analysis from Belgammel A

	Number	%
Amorphous organic matter	177	37.7
Plant cuticles	153	32.6
Fungal spore	29	6.2
Burnt amorphous	27	5.8
Fecal pellets	21	4.5
Thermally mature woody	19	4.1
Fungal hyphae	13	2.8
Marine cysts	8	1.7
Pollen	7	1.5
Insect	5	1.1
Inertinite	3	0.6
Freshwater algae	3	0.6
VAM	3	0.6
Spherule	1	0.2
<b>Total</b>	<b>469</b>	

The samples were subdivided and part was submitted for Accelerator Mass Spectrometry (AMS) radiocarbon dating using standard techniques and calibrated using the CALIB program (Reimer *et al.*, 2004). The other part of the same samples was processed for palynology using standard methods (Hunt, 1985): the samples were treated with hydrochloric acid 10% to remove carbonates, then neutralized and boiled in potassium hydroxide 5% to remove humic matter. The resultant suspensions were sieved through 100  $\mu\text{m}$  nylon mesh to remove coarse sand and organic matter, then on 5  $\mu\text{m}$  nylon mesh to remove fine particulates and solutes. The Belgammel B sample was further treated with concentrated nitric acid to remove pyrite. The samples were neutralized, stained with safranin and mounted for microscopic examination in Gurr Aquamount (results are shown in Tables 1–3).

### Dating

The details of the samples and the dating results are shown in Table 1. The wood from Belgammel B gives a broad 3rd- or 4th-century BC age. This represents only the time when the wood was growing: the ram was built



**Table 3.** *Organic-walled microplankton from Belgammel A*

	Number	%
<i>Spiniferites</i> spp.	23	35.4
<i>Saepodinium</i> sp.	16	24.6
<i>Xandarodinium</i> sp.	8	12.3
<i>Polykrikros schwartzii</i>	4	6.2
<i>Peridium</i> sp.	2	3.1
<i>Lejeunacysta</i> sp.	2	3.1
<i>Operculodinium</i> sp.	2	3.1
<i>Achomospaera</i> sp.	1	1.5
<i>Hemicystodinium</i> sp.	1	1.5
<i>Hemicystodinium zoharyi</i>	1	1.5
<i>Michrystridium</i> sp.	1	1.5
<i>Protopteridium</i> sp.	1	1.5
<i>Spiniferites mirabilis</i>	1	1.5
<i>Veryhachium</i> sp.	1	1.5
<i>Votadinium</i> sp.	1	1.5
<b>Total</b>	<b>65</b>	

later than this and thus most probably in or just after the last two centuries BC. The sediment from Belgammel A dates, broadly, from the 6th–8th centuries BC. Unfortunately, this date lies across a plateau in the calibration curve and so is rather spread. The date, however, is clearly older than the date for the wood. This is consistent with there being substantial older carbon in the sediment, derived perhaps from soils eroding from the Wadi Belgammel catchment, or from older wood in the ram.

Since the wood and sediment samples were recovered from a marine environment it was necessary to confirm that the material being dated is of terrestrial origin. The  $^{13}\text{C}$  figures in Table 1 provide evidence of the extent that these samples are composed of terrestrially derived carbon and in both cases, these are essentially terrestrial figures. The calibrated dates use the INTCAL09 calibration curve and are expressed at 2 standard deviations (95.4%) probability – in other words there is better than 19 chances out of 20 that the date will fall within the calibrated ages. The calibration curve for the 1st millennium BC is highly complex, because of the irregular production of  $^{14}\text{C}$  in the upper atmosphere at that time. The calibrated dates are where the measured  $^{14}\text{C}$  age intersects with the calibration curve.

### Sediments

Remarkably little is known about pre-Roman classical environments in Northern Libya. In contrast, the environment from the 1st century AD in the region is comparatively well known from the work of the UNESCO Libyan Valleys Survey in Tripolitania and new work in Cyrenaica by the Cyrenaican Prehistory Project. These show that Roman-period agriculture had a significant effect on the landscape, with widespread irrigation systems and livestock-stalling in interior Tripolitania leading to high biodiversity in a well-vegetated steppe-

scrub landscape with extensive cultivation of olives, barley and other crops (Hunt *et al.*, 1987; Gilbertson and Hunt, 1996; Gilbertson *et al.*, 1996; Hunt *et al.*, 2001). Some initial outline results from the Cyrenaican Prehistory Project suggest that Roman-period cereal and olive farming in coastal Cyrenaica was rather intensive and led to considerable land degradation (Barker *et al.*, 2008). It is possible that a few poorly dated reconnaissance samples from wadi-fills in Cyrenaica which show olive and cereal cultivation and probably grazing in a *maquis*-like environment (Hunt *et al.*, 2002) may date to the pre-Roman Classical period, since these do not show the level of impact typical of the Roman period in the region. The Belgammel Ram gives us a rare opportunity to examine well-dated environmental samples from the 4th and 3rd centuries BC in Cyrenaica.

### Palynofacies and palynology

The samples were very different in character. Belgammel A contained a rather sparse assemblage consisting of various structured and unstructured organic matter (palynofacies: Hunt and Coles, 1988), organic-walled microplankton and pollen. Belgammel B contained only very large amounts of thermally mature woody matter. The palynofacies analysis from Belgammel A is shown in Table 2. Belgammel A contains a marine component, consisting of faecal pellets (which are typically derived from small marine arthropods such as shrimp) and marine cysts (Batten, 1982). A freshwater component consists of the non-marine algae. There is also a terrestrial component, including the plant cuticles, pollen, insect fragments, inertinite (derived from bedrock) and most of the fungal debris. Vesicular Arbuscular Mycorrhizae (VAMs) are fungal symbionts on plant roots. Burning is shown by the thermally mature woody matter, the burnt amorphous matter and the spherule (which is blackish-brown in colour as is typical of spherules produced before the modern period).

### Organic-walled microplankton

The assemblage (Table 3) is dominated by marine cysts, but with a large non-marine component. The two freshwater forms are *Saepodinium* sp., which is typical of shallow, base-rich, moderately eutrophic freshwaters (Hunt *et al.*, 1985) and *Peridium* sp. cysts, which are common in most freshwater environments. The marine cysts include an open-marine Mediterranean component, *Spiniferites* spp., *Operculodinium* sp., *Hemicystodinium* spp., *Achomospaera* sp., and a shallow, marginal-marine component, *Xandarodinium* sp., *Polykrikros schwartzii*, *Lejeunacysta* sp., *Protopteridium* sp. and *Votadinium* sp. The marginal-marine taxa are often found in large numbers in turbid eutrophic environments such as harbours. The acritarchs *Michrystridium* sp. and *Veryhachium* sp. are so rare at the present day that their ecology is largely unknown.

**Table 4.** Pollen analysis from Belgammel A

	Number	%
Chenopodiaceae	18	26.5
Lactucaee	10	14.7
Poaceae	9	13.2
Pteropsida	4	5.9
<i>Helianthemum</i>	3	4.4
<i>Quercus</i>	3	4.4
<i>Armeria</i>	2	2.9
<i>Artemisia</i>	2	2.9
<i>Centaurea</i>	2	2.9
Cyperaceae	2	2.9
<i>Juniperus</i>	2	2.9
<i>Allium</i> type	1	1.5
<i>Asphodelus</i>	1	1.5
<i>Bellis</i> type	1	1.5
<i>Bidens</i> type	1	1.5
Cereal	1	1.5
<i>Ephedra</i>	1	1.5
<i>Erica</i>	1	1.5
<i>Olea</i>	1	1.5
<i>Rumex</i>	1	1.5
<i>Thymus</i>	1	1.5
<i>Tuberaria</i>	1	1.5
<b>Total</b>	<b>68</b>	

### Pollen

Pollen was not abundant in the sample (Table 4), and the number of broken grains present, and the high frequency of Lactucaee pollen, are consistent with a degrading environment, as they are highly resistant and are therefore over-represented in such places (Hunt, 1994) Chenopodiaceae (goosefoot family) pollen are the most frequent in the sample. These are common in interior subdesert environments on the backslope of the Jebel Akhdar in Cyrenaica, but are also very common as agricultural weeds in fields and they flourish in coastal localities including dune slacks, the margins of saline lagoons and the edges of estuaries.

A number of taxa are typical of more-or-less heavily grazed steppe-like or *garrigue* environments, including Lactucaee (dandelion group), Poaceae (grasses), *Helianthemum* (rockrose), *Armeria* (thrift), *Artemisia* (wormwood), *Centaurea* (knapweed), Cyperaceae (sedges), *Allium* (onion), *Asphodelus* (asphodel), *Bellis*-type (daisies), *Bidens*-type (bur-marigolds), *Rumex* (sorrels) and *Thymus* (thymes) (Polunin and Huxley, 1987; Stace, 1999). *Tuberaria* (sun-rose) and *Ephedra* (crack-pine) are found in *maquis* in Cyrenaica, although *Ephedra* is also found in desertic environments south of Jebel Akhdar. *Juniperus* (juniper) is predominant in exposed coastal woodlands in Cyrenaica, while *Quercus* (oak) is rarely found in coastal localities today. It is more common in wooded wadis inland, such as the Wadi Kouf. Cereal, *Olea* (olive) and *Allium* and possibly some of the weedy taxa, particularly the Chenopodiaceae and Lactucaee, may be consistent with arable agriculture.

### Interpretation

The samples from the Belgammel Ram give a mixed picture. There are clear signs of fire; the dark brown to black colours of the thermally mature wood of Belgammel B suggests charring in temperatures in the region of 400–500°C. This may suggest that the vessel to which the ram was attached had been affected by fire. There are also traces of fire in Belgammel A, but as charred material is almost inert chemically and recycles repeatedly in the environment, this may reflect earlier events on shore. The marine component of the palynofacies and microplankton assemblages and the high count for Chenopodiaceae are consistent with the ram coming to rest in a nearshore marine environment, while the marginal-marine cysts are suggestive of turbid nearshore or estuarine conditions. The non-marine cysts are consistent with a nearby freshwater input, and terrestrial run-off is suggested by the fungal debris, VAMs and plant cuticles. It is probable that the estuarine, terrestrial and freshwater material in Belgammel A arrived as a result of dense sediment-laden floodwater from the Wadi Belgammel spreading out across the sea-floor, following heavy rain, and entering the interstices of the wreck.

The pollen assemblage is too small and the taphonomy is too unusual for detailed interpretation, but there are indications of seashore, coastal and wadi semi-natural vegetation, perhaps some minor arable activity and fairly widespread or local grazed land. Given the taphonomic differences, these are reasonably comparable with the reconnaissance samples of Hunt *et al.* (2002), reinforcing the deduction that these may reflect events of pre-Roman age. It is suggested, therefore, that future work will demonstrate that significant intensification of agriculture and landscape degradation only occurred in Cyrenaica with the Roman occupation.

## Surface analysis of the Belgammel Ram

### Summary of techniques

The purpose of the methods used in this section is to provide an archive of quality images of the surface of the ram from the point of view of surface relief, texture, markings, colour, possible identification of corrosion products, the state of preservation of the surface, any changes in the surface through time, and its 3D geometry. A series of complementary techniques was employed to provide as rich an archive as possible in order to facilitate future research. The data volumes obtained are large, and scholars requiring original data should contact the authors. The techniques used were: laser scanning using a Konica Minolta 910 non-contact digitiser, producing 307,000 sample-points per scan (a total of 80 scans were produced) (Fig. 7); Reflectance Transformation Imaging (RTI) to capture surface morphology (Fig. 8); Digital Photogrammetry-Dense Surface Modelling, using a Nikon D300 with high resolution of 4000 × 3000 pixels and PhotoModeler Scanner



(Fig. 9); 3-D Optical White Light Scanner, using Breuckmann stereoScan system, controlled by Optocast R2 Software and Geomagic Studio 10 post-processing software (Fig. 10).

RTI summarizes a range of techniques for deriving surface information from a series of photographs with varying lighting positions. For this study two techniques have been used: polynomial texture mapping (PTM) (Malzbender *et al.*, 2001) and hemi-spherical harmonics (Gautron *et al.*, 2004). Recent summaries of the archaeological potential of these techniques are found in Earl *et al.* (2010a) and Happa *et al.* (2010). The RTI data captured provide an interactive record of the surface preservation of the ram, and enable the identification of subtle surface deviations. Future capture using the same technique would enable

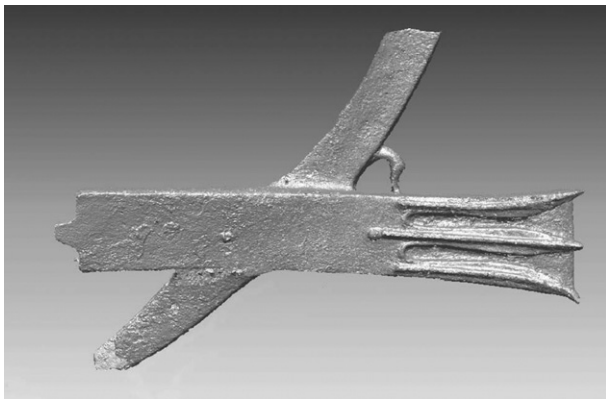

Figure 7. The Belgammel Ram recorded as a laser image, 2009. Data processed on Polygon Workbench and Rapid-Form. (Earl and Adams, University of Southampton)

metric comparison of normal datasets to identify modifications to the surface morphology (Earl *et al.*, 2010b). The combination of fitting algorithms enabled complementary capture of diffuse and specular detail.

Once processed, PTM images enable a surface to be relit interactively. The viewer enables one or more light sources to be moved to any position in a hemisphere above the surface, and their relative intensity adjusted. In addition various image-processing algorithms can be applied interactively, and annotations made and shared which respect the current lighting and other settings. One might therefore regard PTM as the ultimate finds record photograph that can be accessed digitally via the web, rendered to a still image, and modified to suit a great many requirements.

## X-radiography and X-ray tomography

### Objective and equipment

The Non-Destructive Evaluation laboratory at AWE first conducted a digital radiography trial, followed by three separate 3D Computed Tomography (CT) experiments. The purpose was to identify aspects of the internal structure of the alloy which would assist understanding of the casting procedure and manufacture of the ram.

The equipment used to capture the raw information for the CT reconstruction was a High Energy 'MINAC' X-ray set which can be operated at 4–10 MeV, with dose adjustment through pulses, and a 5-degree beam collimator. The X-ray images were captured on a digital flat-panel detector coupled to a PC-based image-acquisition and manipulator control-system which sequenced image acquisition with

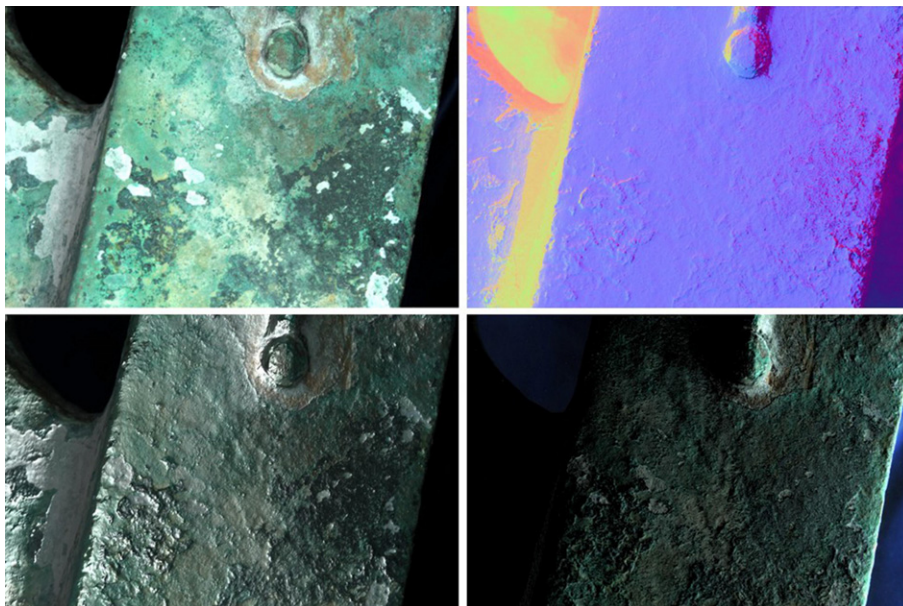

Figure 8. RTI dataset using the Polynomial Texture Mapping (PTM) algorithm to enable visual enhancement. Clockwise from top left: diffuse colour view; surface normal vector view (where red, green and blue define surface shape); diffuse view with oblique virtual light source; specular enhanced view. (Earl and Adams, University of Southampton)

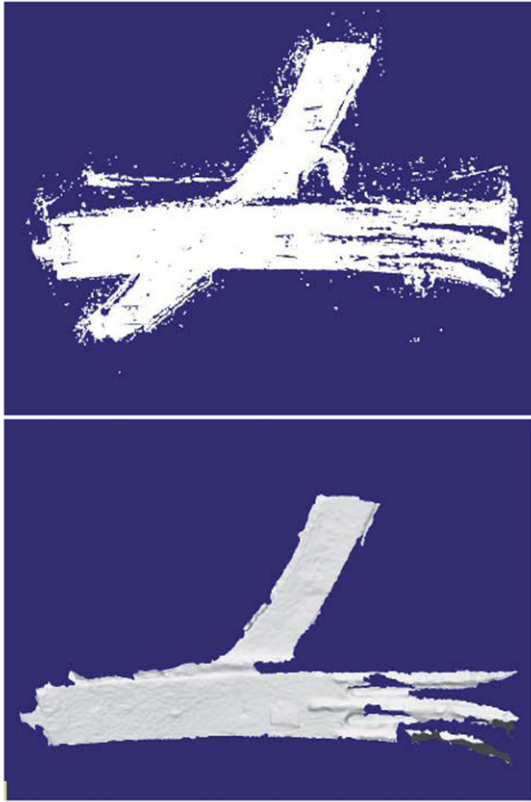

Figure 9. Digital PhotoModeler Scanner digital photogrammetry, point cloud (upper) and surface model (lower). Representative image. (Earl and Adams, University of Southampton)

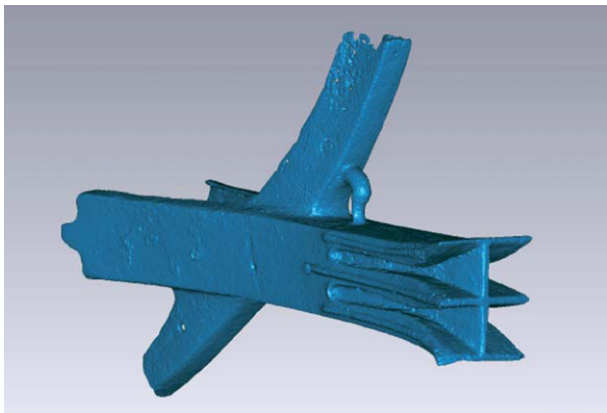

Figure 10. Completed Belgammel Ram data set in Geomagic Studio. (Crown copyright)

incremental rotation of the sample placed on a turntable between the X-ray source and detector. The resultant X-ray images were reconstructed into a 3D volume and analysed using Volume Graphics Studio Max Version 2, a commercial 3D visualisation software package installed on a 64-bit reconstruction PC. The images can be rotated and analysed on the screen.

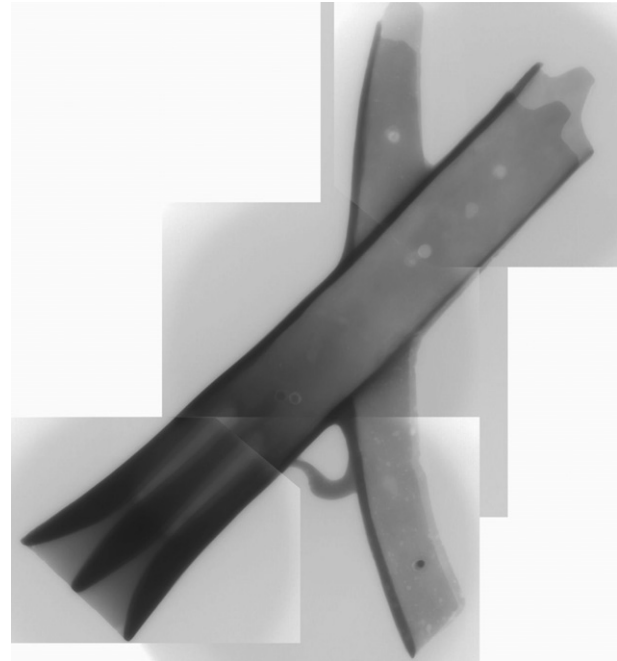

Figure 11. Composite radiograph of the ram. This is a positive image so that thicker metal is darker. (Crown copyright)

The volumes of data produced are very large, and this paper only provides a few images and summary interpretation. Researchers wishing to analyse the data themselves should contact the Southampton archive at: Faculty of Engineering and Environment, Engineering Sciences, Material Data Centre, University of Southampton (muvis@soton.ac.uk) and request CD/DVDs of the raw data or the numerous processed images on file. The data are best analysed using appropriate computer visualisation tools.

#### *X-radiography*

A series of images was obtained using different power settings depending on the metal thickness in the area of the image. These radiographs can be viewed separately, and were combined to give an overall view (Fig. 11).

#### *Computed tomography trials*

The ram was mounted on a turntable which could be rotated automatically in steps of 1°, with successive X-ray digital images obtained at each step. The screen data were downloaded after each step. Because of the size and shape of the ram only parts of the total casting could be processed in each run. The three trials consisted of the front section with the blades, the mid-section with the junction to the upper and lower sections of the cowl, and finally the swan-neck bracket and the upper cowl. The volumetric point-cloud for each trial was processed to create a 3D visual representation, with slice information and surface rendering. The data was then combined with a 3D surface plot created with White Light Scanning equipment to generate a complete 3D model. This model was then used

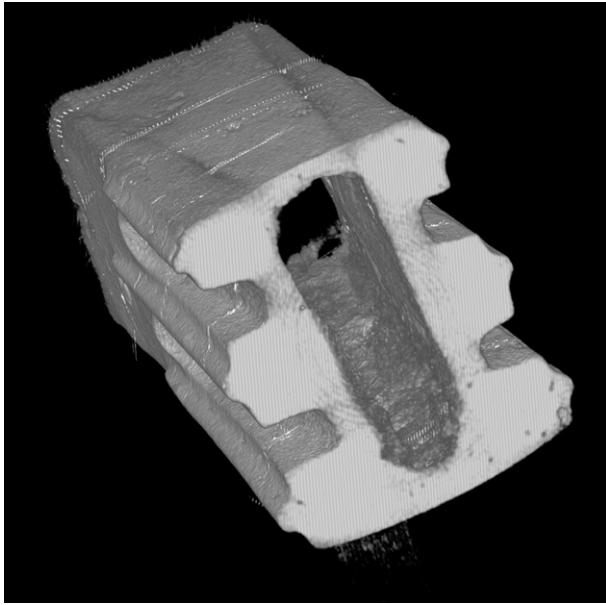

Figure 12. Reconstruction of the section of the front of the ram from X-ray Computed Tomography data. (Crown copyright)

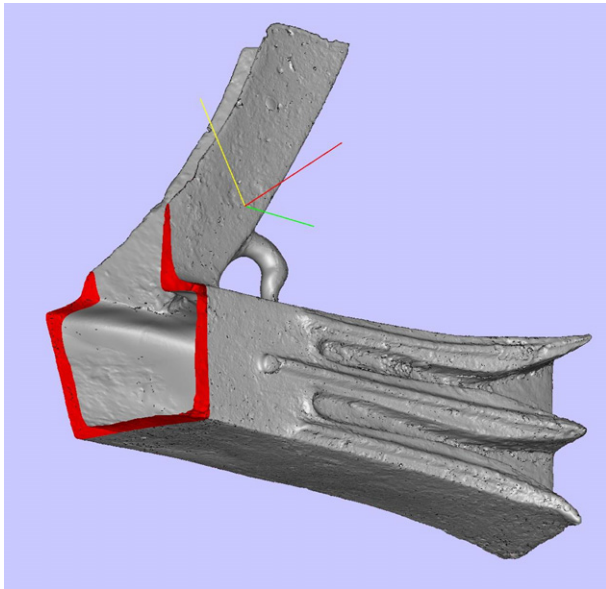

Figure 13. 3D image of the cross-section of the centre of the ram. (Crown copyright)

to generate a 3D Mesh representation of the ram for Finite Element Analysis. Figures 12 and 13 are selected images to illustrate the quality of the results. Figure 14 shows X-ray tomography reconstruction of the blades of the ram showing intense porosity.

### Interpretation of results

The following interpretation of the casting and cooling of the ram should be regarded as preliminary. The data

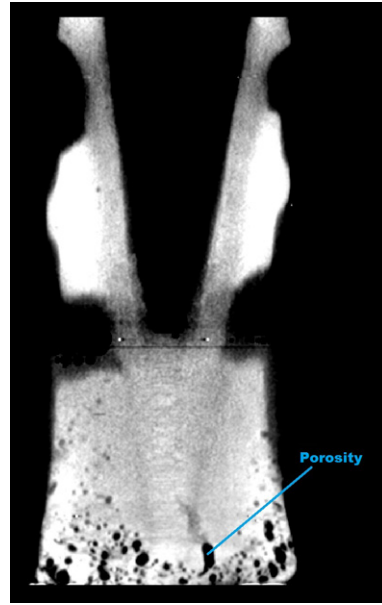

Figure 14. Ram lower section 2-D slice showing extreme porosity at the tip of the blades. (Crown copyright)

are available for other scholars who wish to conduct further analysis. We note the following points: large spherical porosity near to and breaking the surface of the casting; there is some evidence of surface scaling and repairs to some of the thinner sections; the surface of the ram perpendicular to the prow extensions is slightly tapered in cross section; the longer, less-uniform pores in the thicker sections adjacent to thinner sections are shrinkage porosity caused by the thinner sections solidifying first and trapping gases; pore-clusters imply regions where the gas had nowhere to escape, suggesting insufficient risers.

The technology of casting the ram is highly advanced: it is inferred from the available evidence that it was cast in a single pour, with no evidence of any subsequent forging or joining of pieces. The extreme variation of thickness means that cooling-rates and solidification were strongly varied. The main question is whether it was cast by the lost-wax method, or sand-cast with a mould. It is interesting that sand-casting had been claimed for the Athlit Ram, but the most recent technical study concluded that lost-wax casting is securely proven (Oron, 2006).

There is no evidence from the ancient world for the use of sand as a casting material for bronze. Mattusch (1977: 342, n.8), in discussing the evidence for bronze casting at the Athenian Agora, states: 'All of the foundry remains which I have examined indicate that throughout antiquity only the lost-wax (*cire perdue*) method of casting, in its direct or indirect form, was used to produce both large and small bronzes'. There is abundant evidence for the use of ceramic moulds from the ancient world (for example, Mattusch, 1977; Riha and Stern, 1982; Rabeisen, 1990; Bayley and Budd, 1998; Chardron-Picault and Pernot, 1999) and there is



enough evidence to show that ceramic continued to be the main moulding material up to the 18th century AD.

The high porosity in this casting could be characteristic of sand rather than lost-wax casting, since moisture in the sand can out-gas and cause porosity in the surface of the metal. But pre-modern castings were routinely porous, often to an extent that can seem shocking to a modern metallurgist. The idea that sand-casting produces more severe porosity than lost-wax casting seems to be based on modern experience with both techniques: the former is used for routine items while the latter is used for high-specification items (such as turbine blades) where any significant porosity is unacceptable.

The absence of any casting-seam also indicates that casting was not made using a sand-mould. While casting-seams may have been removed from prominent parts of the finished casting, this would be difficult on many parts of the ram. Finally, the shape of the artefact seems to preclude the possibility of sand-casting with a two-piece mould. A sand-mould must have a separation-line, but the shape of the ram includes portions in both halves which curve in two planes perpendicular to each other. Such a complex object can only have been manufactured in a sand-mould if the mould included at least four separate sections. Alternatively the ram could have been, and probably was, made using lost-wax casting.

### Microanalysis and lead-isotopes

Microanalytical techniques were applied to samples taken as micro-drilled turnings from the Belgammel Ram. Scanning electron microscopy with back-scatter electron imagery (SEM-BEI) showed subtle variations in the composition of the Cu-Sn alloy. Micro-XRF analysis provided a general chemical composition of the bulk bronze and also allowed the chemical changes produced by corrosion to be determined. Lead-isotopic ratios provided some insights into possible lead sources, although identification of the sources of the

lead used is complicated by the possibility that the metal may have been re-melted and mixed with other bronze on one or more occasions.

#### *Sub-sampling of the ram*

Nine samples (Fig. 15) were taken from the ram by manual micro-drilling and *c.* 50-mg samples were taken at each sample site. A portion of each of the metal turnings was mounted in resin blocks and polished to a flat surface. Another fraction was accurately weighed and dissolved in sub-boiled nitric acid in preparation for lead-isotopic analysis.

#### *Micro-XRF analysis*

The details of the laboratory procedure will be published elsewhere (Croudace *et al.*, forthcoming). Of the nine samples, eight were used to provide data on the composition of the internal alloy, producing the results for the average percentage composition Cu = 86.9, Sn = 6.3, Pb = 6.6, and Zn  $\leq$  0.10. The range of percentage Cu was from 90.94 to 82.99; the range of percentage Sn was 8.5 to 6.4; and the range of Pb was 10.1 to 1.6. The percentage of Zn was less than 0.1 in all samples.

The general compositional analysis of the ram obtained using micro-X-ray fluorescence analysis showed the bronze to be rich in lead with up to 10 wt% being recorded, but the higher values reflect apparent enrichment due to corrosional loss of Cu. The amount of lead measured shows some variability and reflects its non-homogenous distribution. Overall the alloy of the ram can be described as a leaded bronze.

#### *Chemical effect of corrosion*

The appearance of the ram shows it has been affected by weathering and corrosion during its long stay in the marine environment (Fig. 16). It appears remarkably stable and has not suffered so-called bronze disease. The overall effect in the surface layer has been to concentrate the less affected metals (Sn and Pb) relative to the Cu that is being lost (Table 5).

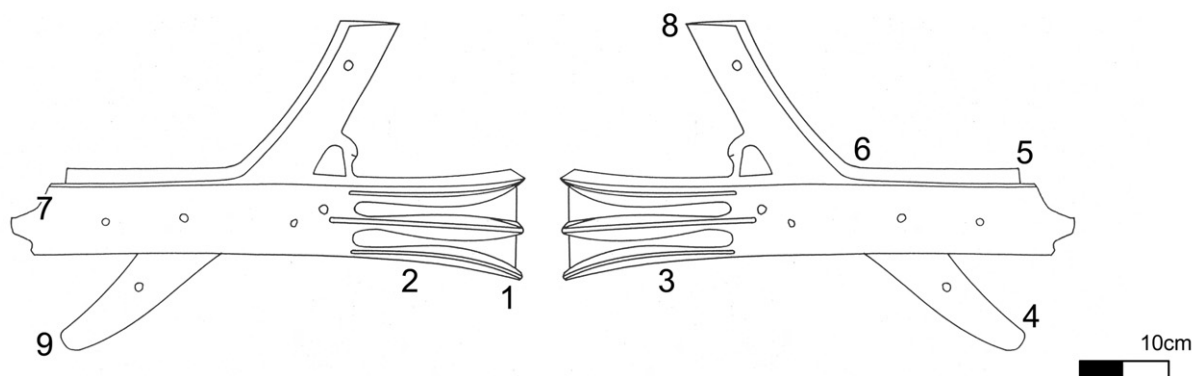

Figure 15. Schematic figure to show the approximate locations of the micro-drilled sub-samples taken from the Belgammel Ram. (After M. Pridemore drawing, 1996: fig. 26)

**Lead isotopes by multi-collector ICP-MS**

Approximately 500 µg of bronze was taken for lead-isotopic analysis by multi-collector ICP-MS (Thermo Neptune). Lead was purified from the samples by anion exchange chromatography, and the isotope ratios measured using static multi-collection (Table 6).

**Results and discussion**

Copper and tin form a solid solution series in bronze alloys and it is known that elemental lead has a low

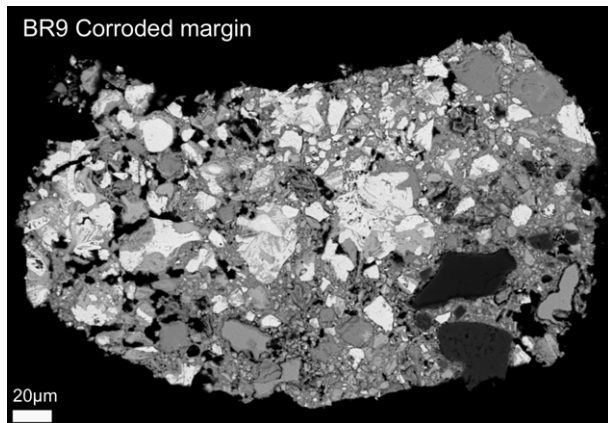

**Figure 16.** SEM backscatter image showing lead (white) and Cu-Sn (grey) on the corroded edge of the Belgammel Ram. Significant loss of copper is noted in some surface areas that have suffered corrosion. (Croudace, University of Southampton, NOC)

solubility in such alloys and is not mixed to any significant extent. Lead forms a separate, almost pure, phase in bronzes and is added to improve certain characteristics of the bronze (Scott, 1991: 23–24).

The chemical composition of the ram is in keeping with the sort of alloy used for large castings in late Classical, Hellenistic and Roman times (Craddock, 1977). The copper-tin ratio of the alloy is similar to the Athlit Ram (Oron, 2006), but the Athlit Ram contains no lead. In contrast, the Acqualadroni *rostrum* found near Messina in 2008 contained 70% copper, 10% tin, and 20% lead (Caruso *et al.*, 2011). Thus it appears that we have much to learn as to how and why lead was added to bronzes for different purposes. Lead appears to have been a routine addition to some large bronze castings and would have helped lower the melting temperature of the alloy and extend the temperature range over which the alloy would solidify. In addition, lead is usually thought to decrease the viscosity of molten bronze and so improve the ability faithfully to reproduce the mould shape. However, since the Athlit Ram is larger than the Belgammel Ram it is not clear why the lead is added in the latter's composition.

Alpha-delta eutectoid and lead will all tend to solidify last and so are found within the inter-dendritic spaces. As they are cast and get cooler, dendrites have dendrite arms arranged perpendicular to each other (although dendrites in different crystals are irregularly orientated with respect to each other). If cast bronze is forged then the dendritic coring becomes distorted and

**Table 5.** Micro-XRF analysis of corrosion products from the Belgammel Ram (analysis using the EAGLE III with a 277µm spot size)

Sub-sample	Cu wt%	Sn wt%	Pb wt%
Rivet (fresh)	90.77	6.67	2.16
Rivet (corroded)	71.06	24.16	3.55
Sample BR9 (Fresh)	85.70	3.83	10.09
Corrosion product on surface of Ram (a)	45.12	41.99	10.41
Corrosion product on surface of Ram (b)	38.98	45.54	15.18
Corrosion product on surface of Ram (d)	22.64	52.61	20.50

**Table 6.** Lead isotopic ratio data for sub-samples of the Belgammel Ram. The lead isotopic ratios for three samples (Belgammel Ram 2, 4, and 6 in Fig 15) are tabulated with the 2-standard deviation error estimates. Errors refer to the final quoted significant figures. Reference sample NIST 981 data are from analyses completed in the same run as the ram measurements. Laboratory double spike data of NIST 981 made during this analytical period are  $16.9406 \pm 35$ ,  $15.4980 \pm 35$  and  $36.7188 \pm 86$  ( $\pm 2sd$   $n = 15$ ) – errors refer to the final quoted significant figures

	$^{206}\text{Pb}/^{204}\text{Pb}$	$^{207}\text{Pb}/^{204}\text{Pb}$	$^{208}\text{Pb}/^{204}\text{Pb}$	$^{208}\text{Pb}/^{206}\text{Pb}$
BGR2	18.8392	15.6860	38.8664	2.06306
BGR4	18.8371	15.6832	38.8605	2.06298
BGR6	18.8405	15.6858	38.8647	2.06283
+/- 2sd	38	27	63	25
NIST981-1	16.9429	15.4969	36.7113	2.16677
NIST981-2	16.9430	15.4978	36.7122	2.16681

eventually the coring comprises a series of parallel dark and light bands. The samples taken from the ram show alpha-delta eutectoid and lead distributed evenly in a way which suggests that the metal has been cast into shape and received no subsequent forging. There are on some samples slight indications of distortion but this could have been the result of the sampling procedure (drilling).

## Conclusions

The Belgammel Ram is the new name for the ram previously known as the Fitzwilliam Ram. Origin, provenance, and continuous history of ownership are provided in this paper. Comparison of photographs from the time of recovery in Libya, modern photographs, and the personal views of people who have worked with the Belgammel Ram at various times over the 48 years since its recovery, indicate that the bronze surface is chemically stable, although in some areas the surface layer has been relatively depleted in copper during its period of immersion in salt water.

The date of manufacture and loss of the Belgammel Ram have not been fixed precisely. Charred wood found inside the ram indicates a date during the first two centuries BC, while the decoration of the trident motif and swan neck suggest a date in the 1st century AD. These are not irreconcilable, since the wood can have been used for a long time, and the decorative motifs may have been adopted earlier than comparative analysis suggests. Nevertheless, it is fair to say that work needs to be done to arrive at a more secure date.

The composition of the bronze alloy is approximately 87 wt % Cu, 7% wt Sn, and 6% wt Pb, with Zn less than 0.1 wt %. While numerous sources, both ancient and modern, confirm that adding lead to a bronze is a common technique to improve casting accuracy and easy flow of the liquid metal, it is anomalous that the much larger Athlit Ram consists of a lead-free bronze alloy. The ram was cast in one pour, and there are no joints in its manufacture. Since different parts are massively thick and others quite thin, the rates of cooling were very different. X-ray tomography shows that porosity is most consistent with a lost-wax technique, although some factors suggest that a sand-mould was used. The undisturbed crystal dendritic structure of the copper-rich material which solidifies first during cooling indicates that the metal was not forged or worked after cooling.

The ship it was designed for was most probably a *tesseraria*, a small naval patrol-vessel, or a scout or message vessel supporting a larger fleet. The reason for

## Acknowledgements

Laboratory facilities for this exercise were provided free of charge, and the authors express gratitude to the School of Earth and Ocean Science, University of Southampton; the Dept. of Archaeology, University of Southampton; the Department of Non-Destructive Evaluation AWE, and the School of Geography, Archaeology and Palaeoecology, Queen's University Belfast.

Ken Oliver inherited the Belgammel Ram and held it in temporary ownership, making it available for research. Paul Bennett, then Chairman of the Society for Libyan Studies, provided the opportunity to work on the ram while the Society for Libyan

the Belgammel Ram being at a depth of 25 m off the coast of Libya is not known. It could have been part of the cargo of a ship carrying scrap metal for re-use, or it could have been lost directly in a battle or storm which caused the vessel to capsize and sink. There are indicators of fire in the carbonized wood, but the bronze shows no signs of intense heating. This is difficult to explain, since the wood was found inside the ram.

## Future research recommended

As an addition to the limited but growing assemblage of rams from Antiquity, the investigation of the Belgammel Ram has contributed new information and provided useful comparative data. It has also raised questions still to be answered and an obvious step, if possible, would be to subject other known rams to some of the same methods of recording and analysis used here. Many of these techniques have been developed since their discovery, and as new tools and methods of enquiry allow new questions to be asked, we may discover significantly more, not only of individual rams but of Classical and Hellenistic-Roman naval warfare in general. The discrepancy in derived dates for the Belgammel Ram should not be concealed. The iconography suggests a later date than the radiocarbon dating of the wood, and it is hoped that future research will resolve the problem. There is a date zone of near-overlap, but such uncertainty is a matter for attention.

The high lead bronze of the Belgammel Ram contrasts with the pure copper bronze of the Athlit Ram. It is possible that the increased addition of lead is a later technique, and that eastern Mediterranean or Egyptian large bronzes did not often use lead. This needs further analysis, and comparison with recently discovered rams. The casting technique of the Athlit Ram is securely identified as lost wax. For the Belgammel Ram this is the most likely method. Since sand-casting appears to have been used to cast lead anchor-stocks on to wooden shanks, this may have been a coarse shipyard industrial technique. Further research is needed here.

The number of known ancient rams is still tantalizingly small, although more are being found under the sea, and already the variation of size, shape, and metallurgical composition hints at a wide range of technical devices of different dates, and with slightly different functions, though all worthy of the categorization ram, or *proembolion*. In the next few years more rams are likely to be discovered by underwater research, and the study of these artefacts should be pursued as vigorously as possibly using all available laboratory techniques.



Studies negotiated its return to Libya, and is now Head of Mission. The Society for Libyan Studies financed design and printing of a brochure of the initial laboratory results; Nic Flemming co-ordinated the research and publications of the team. Graeme Earl and Jon Adams supervised the optical and laser studies. Ian Croudace, Richard Pearce and Rex Taylor conducted and co-ordinated the geochemical investigations, involving micro-XRF, SEM and lead-isotope analysis. Tim Whiteside and John Moggeridge conducted the X-Ray tomography and Jon Thompson the white-light scanning. Annita Antoniadou did the pollen analysis. Chris Hunt prepared and submitted the samples for radiocarbon dating and did the organic-walled microplankton and palynofacies analysis. Professor Paula Reimer at the 14CHRONO Centre at Queen's University, Belfast, provided the radiocarbon dating.

## References

- Barker, G., Basell, L., Brooks, I., Burn, L., Cartwright, C., Cole, F., Davison, J., Farr, L., Grün, R., Hamilton, R., Hunt, C., Inglis, R., Jacobs, Z., Leitch, V., Morales, J., Morley, I., Morley, M., Pawley, S., Pryor, A., Reynolds, T., el-Rishi, H., Roberts, R., Simpson, D., Stimpson, C., Touati, M. and van der Veen, M., 2008, The Cyrenaican Prehistory Project 2008: the second season of investigations of the Haua Fteah cave and its landscape, and further results from the initial (2007) fieldwork, *Libyan Studies* **39**, 175–221.
- Barr-Sharrar, B., 1994, The bronze appliques, in G. Hellenkemper Salies (ed.), *Das Wrack. Der antike Schiffsfund von Mahdia, I*. 559–72. Cologne.
- Batten, D. J., 1982, Palynofacies, palaeoenvironments and petroleum, *Journal of Micropalaeontology* **1**, 104–14.
- Bayley, J. and Budd, P., 1998, The clay moulds, in H. E. M. Cool and C. Philo (eds), *Roman Castleford. Excavations 1974–85. Volume I: the small finds*. West Yorkshire Archaeology Service, Wakefield.
- Beltrame, C., 2002, *Vita di bordo in età romana*. Rome.
- Ben-Eli, A. L. (ed.), 1975, *Ships and Parts of Ships on Ancient Coins I*. Haifa.
- Buccellato, C.A. and Tusa, S., 2009, Il rostro, in M.L. Famà (ed.), *Il Museo Regionale 'A.Pepoli' di Trapani Le collezioni archeologiche*, 333–34. Bari.
- Caruso, F., Saladino, M.L., Spinella, A., Di Stefano, C., Tisseyre, P., Tusa, S., Caponetti, E., 2011, Physico-chemical characterization of the Acqualadronne rostrum, *Archaeometry* **53**, 3: 547–62
- Casson, L., 1995, *Ships and Seamanhip in the Ancient World*. 2nd edn, Princeton.
- Casson, L. and Steffy, J. R., 1991, *The Athlit Ram*. College Station, TX.
- Chardron-Picault, P. and Pernot, M., 1999, *Un Quartier Antique d'Artisanat Métallurgique à Autun*. Paris.
- Craddock, P. T., 1977, The composition of the copper alloys used by the Greek, Etruscan and Roman Civilisations 2: The Archaic, Classical and Hellenistic Greeks, *Journal of Archaeological Science* **4**, 103–23.
- Croudace, I. W., Taylor, R. N., Pearce, R., Bates, J., and Flemming, N.C., (forthcoming), Microanalytical, textural and lead isotope characterization of the Belgammel Ram, a Hellenistic Roman naval ram, *Journal of Archaeological Science*.
- DRASSM, 2005, *Bilan Scientifique du Département des Recherches Archéologiques Sous-Marines 2003*. Paris/Marseilles.
- Earl, G. P., Beale, G., Martinez, K. and Pagi, H., 2010a, Polynomial texture mapping and related imaging technologies for the recording, analysis and presentation of archaeological materials, 218–23 in: Mills, J.P., Barber, D.M., Miller, P.T., and Newton, I. (ed.), ISPRS Commission V Midterm Symposium, Newcastle, UK, Newcastle.
- Earl, G. P., Martinez, K. and Malzbender, T., 2010b, Archaeological Applications of Polynomial Texture Mapping: Analysis, Conservation and Representation, *Journal of Archaeological Science* **37**, 2040–50.
- Ermeti, A. L., 1981, *Il Monument Navale. Testo e Tavole*. Vol. III.1 of L'Agora di Cirene 9, Rome.
- Gautron, P., Krivanek, J., Pattanaik, S. and Bouatouch, K., 2004, A novel hemispherical basis for accurate and efficient rendering, 321–30, in: Jensen, H.W., and Keller, A., (ed.). *Rendering Techniques 2004*, Eurographics symposium on Rendering, Norrköping, Sweden.
- Gianfrotta, P. A. and Pomey, P., 1981, *Archeologia Subacquea*. Milan.
- Gilbertson, D. D. and Hunt, C. O., 1996, Romano-Libyan Agriculture: Walls and Floodwater Farming. in G. Barker, D. Gilbertson, B. Jones and D. Mattingley (eds), *Farming the Desert: The UNESCO Libyan Valleys Survey, Vol. 1*. UNESCO, Tripoli and Paris: 191–225.
- Gilbertson, D. D., Hunt, C. O. and Smithson, P., 1996, Quaternary Geomorphology and Palaeoecology, in G. Barker, D. Gilbertson, B. Jones and D. Mattingley (eds), *Farming the Desert: The UNESCO Libyan Valleys Survey, Vol. 1*. UNESCO, Tripoli and Paris: 49–82.
- Hale, J. R., 2009, *Lords of the Sea*. New York.
- Happa, J., Mudge, M., Debattista, K., Artusi, A., Gonçalves, A. and Chalmers, A., 2010, Illuminating the past: state of the art, *Virtual Reality* **14**.3, 155–82.
- Hunt, C. O., 1985, Recent advances in pollen extraction techniques: a brief review, in N. Fieller, D. Gilbertson and N. Ralph (eds), *Palaeobiological Investigations*, 181–7. BAR S266, Oxford.
- Hunt, C. O., 1994, Palynomorph taphonomy in the fluvial environment: an example from the Palaeolithic site at High Lodge, Mildenhall, UK, in O. K. Davis (ed.), *Aspects of Archaeological Palynology: Methodology and Applications*, 115–26. American Association of Stratigraphic Palynologists Contributions Series, 29, College Station, TX.
- Hunt, C. O. and Coles, G. M., 1988, The application of palynofacies analysis to geoarchaeology, in E. A. Slater and J. O. Tate (eds), *Science and Archaeology*, 473–84. BAR Brit. Ser. 196, Oxford.
- Hunt, C. O., Andrews, M. V. and Gilbertson, D. D., 1985, Late Quaternary freshwater dinoflagellate cysts from the British Isles, *Journal of Micropalaeontology* **4**, 101–9.
- Hunt, C. O., El-Rishi, H. A. and Hassan, A. T., 2002, Reconnaissance investigation of the palynology of Holocene wadi deposits in Cyrenaica, Libya, *Libyan Studies* **33**, 1–7.

- Hunt, C. O., Gilbertson, D. D., van der Veen, M., Jenkinson, R. D., Yates, J. and Buckland, P. C., 1987, UNESCO Libyan Valleys Survey XVI: The palaeoecology and agriculture of the abandonment phase at Gsur MM10, Wadi Mimoun, in the Tripolitanian Pre-Desert, *Libyan Studies* **18**, 1–13.
- Hunt, C. O., Rushworth, G., Gilbertson, D. D. and Mattingley, D. J., 2001, Romano-Libyan dryland animal husbandry and landscape: pollen and palynofacies analyses of coprolites from a farm in the Wadi el-Amud, Tripolitania, *Journal of Archaeological Science* **28**, 351–63.
- Linder, E. and Ramon, Y., 1981, A Bronze Ram from the Sea off Athlit, Israel. *Archaeology* **34**, Nov-Dec. 62–4.
- Malzbender, T., Gelb, D. and Wolters, H., 2001, Polynomial texture maps, in L. Poccock (ed.) Proceedings of the 28th annual conference on Computer graphics and interactive techniques. ACM, New York, p. 519–28. Doi. 10.1145/383259.383320
- Mattusch, C. C., 1977, Bronze- and ironworking in the area of the Athenian agora, *Hesperia* **46**, 340–79.
- Morrison, J. S., 1996, *Greek and Roman Oared Warships 399–30 BC*. Oxford.
- Murray, W., 1985, The weight of Trireme Rams and the price of bronze in fourth-century Athens, *Greek, Roman, and Byzantine Studies* **26**, 141–50.
- Murray, W., 1988, The spoils of Actium, *Archaeology* **41.5**, 28–35.
- Murray, W., 1991, The provenience and date: the evidence of the symbols, in L. Casson and J. R. Steffy (eds), *The Athlit Ram*, 51–66. College Station TX.
- Murray, W., 1996, Polyremes from the Battle of Actium: some construction details, in H. Tzala (ed.), *Tropis IV, Proceedings of the 4th International Symposium on Ship Construction in Antiquity, 1991*, 335–50. Athens.
- Murray, W. and Petsas, Ph. M., 1989, Octavian's campsite memorial for the Actian War, *Transactions of the American Philosophical Society* **79.4**, 1–172.
- Murray, W., 2011, *The Age of Titans: The Rise and Fall of the Great Hellenistic Navies*. Oxford University Press, New York. p. 356.
- Nicholls, R. V., 1971, The Trinity College collection and other recent loans at the Fitzwilliam Museum, *Archaeological Reports for 1970–71*, 77–85.
- Oron, A., 2001, The Athlit Ram: Classical and Hellenistic Bronze Casting technology. Master's thesis, Texas A & M University. <http://nautarch.tamu.edu/pdf-files/Oron-MA2001.pdf>
- Oron, A., 2006, The Athlit Ram bronze casting reconsidered: scientific and technical re-examination, *Journal of Archaeological Science* **33**, 63–76.
- Parker, A. J., 1992, *Ancient Shipwrecks of the Mediterranean and the Roman Provinces*. BAR S580, Oxford.
- Petrovsky, R., 1994, Die Bronzegefäße, in G. Hellenkemper Salies (ed.), *Das Wrack. Der antike Schiffsfund von Mahdia 1*, 663–700. Cologne.
- Polunin, O. and Huxley, A., 1987, *Flowers of the Mediterranean*. London.
- Pridemore, M. G., 1996, The form, function, and interrelationships of naval rams: a study of naval rams from antiquity, unpublished MA dissertation, Texas A & M University, <http://nautarch.tamu.edu/Theses/pdf-files/Pridemore-MA1996.pdf>.
- Rabeisen, E., 1990, La production d'équipement de cavalerie au Ier s. après J.-C. à Alesia (Alise-Sainte-Reine, Côte-d'Or, France), *Journal of Roman Military Equipment Studies* **1**, 73–98.
- Reimer, P., Baillie, M., Bard, E., Bayliss, A., Beck, J., Bertrand, C., Blackwell, P., Buck, C., Burr, G., Cutler, K., Damon, P., Edwards, R., Fairbanks, R., Friedrich, M., Guilderson, T., Hughen, K., Kromer, B., McCormac, F., Manning, S., Bronk Ramsey, C., Reimer, R., Remmele, S., Southon, J., Stuiver, M., Talamo, S., Taylor, F., van der Plicht, J. and Weyhenmeyer C., 2004, IntCal04 Terrestrial radiocarbon age calibration 0–26 cal kyr BP. *Radiocarbon* **46**, 1029–58.
- Riha, E. and Stern, W. B., 1982, *Die römischen Löffel aus August und Kaiser August*. Forschungen in Augst, band 5. Augst.
- Scott, D.A., 1991, *Metallurgy and microstructure of ancient and historic metals*. Getty Conservation Centre, Los Angeles.
- Stace, C. A., 1999, *Field Flora of the British Isles*. Cambridge.
- Tusa, S. and Buccellato, C., 2008, Il rostro delle Egadi, in AA.VV., *La felicità di un ritorno Arma dei Carabinieri, Guardia di Finanza e Polizia di Stato, un impegno costante per restituire l'Arte rubata all'Umanità. Recuperare per tramandare*, 67. Roma.
- Tusa, S. and Buccellato, C., 2010, Il rostro delle Egadi, in A. Mormino *et al.* (eds), *L'Arma per l'Arte. Beni Culturali di Sicilia recuperati dal Nucleo Carabinieri Tutela Patrimonio Culturale*, 111–13. Palermo.
- Ucelli, G., 1950, *Le Navi di Nemi*. 2nd edn, Rome.