



Guide to Adaptive Rowing

(Updated: February 2015)

ACKNOWLEDGEMENTS

USRowing would like to thank the following people for their contribution to the production of this manual.

Editor: Debbie Hoefler Arenberg

Individual Contributors: Richard Butler, Tom Darling, Ron Harvey, Brett Johnson, Jennifer Kierstead, Beth Kohl, Karen Lewis, Mark McAndrew, Kirsten Meisner, Ellen Minzner, Tara Morgan, Judy Morrison, Regina Navia, Joy Nix, Volker Nolte and the USRowing Safety Committee.

Program Contributions:

- **Bridge2Sports, Durham, N.C.**
- **Community Rowing Inc., Boston, Mass.**
- **Connecticut Adaptive Rowing Program, Conn.**
- **Philadelphia Adaptive Rowing, Pa.**
- **Rio Salado Adaptive Rowing, Ariz.**
- **Southeastern Adaptive Sculling, Ga.**
- **Three Rivers Rowing Association, Pittsburg, Pa.**
- **US Paralympics**
- **U.S. Department of Veteran Affairs**

Rowing Photos: Deb Arenberg, Tom Darling, Brett Johnson, Ed Moran, Row2k, and Hope Wilkinson.

*This manual is dedicated to the adaptive athletes,
families, coaches, volunteers and equipment
manufacturers who have contributed and supported the
growth and development of adaptive and para-rowing.*

**USRowing
2 Wall Street
Princeton, NJ 08540
1-800-314-4ROW
www.usrowing.org**

TABLE OF CONTENTS

Part I – Introduction to Adaptive Rowing

What is Adaptive Rowing? Para-Rowing?	6
Benefits of Rowing for the Disabled Athlete & Rowing Club	9
History of Paralympics	11
Timeline of Adaptive Rowing in the US.....	13
America Rows—Diversity & Inclusion Initiative.....	14

Part II - Learning about Disability

Disability- What to say and how	19
Guidelines for talking about Disability	20
Disability Etiquette	22
American Disability Act Basics.....	24

Part III - Getting Started, FISA Sport Group Classification, Events

What is an adaptive rowing program?	26
Classification for Para-Rowing	27
Spinal Column Description/Function	29
Classification - Leg, Trunk, Arms (LTA)	31
Classification - Leg, Trunk, Arms- Visually Impaired (VI).....	32
Classification - LTA Equipment Considerations	33
Classification - Trunk, Arms (TA)	34
Classification - TA Equipment Considerations	35
Classification - Arms and Shoulders (AS).....	36
Classification - AS Equipment Considerations.....	36
World Rowing Federation (FISA)	38
Para- and non-Para Rowing Events	39
Adaptive Rowing Event Time Handicaps	41
Referee Quick-Reference Guide.....	42
Programming – Plans for long-term success	45

Part IV – Adaptive Checklists & Forms

Facility Accessibility & Checklist	46
Getting the athlete started - initial athlete process	49
Tools - Sample Adaptive Rowing Member Form	51
Safety - Protocol, Supervising an Adaptive Program	53
Safety - Sample of traffic pattern	55
Adaptive Athlete Documentation - Communication	56
Tools - Sample Rigging Cards, Swim/Float Form	57
Coaching - Athlete Progression	59

Part V- Coaching Considerations for Specific Disabilities

Amputation 61
Appliances 62
Cerebral Palsy 63
Cognitive and Brain Impairment..... 63
Traumatic Brain Injury (TBI)..... 64
Post-Traumatic Stress Disorder (PTSD)..... 65
Autism Spectrum Disorder (ASD) 68
Epilepsy 69
Spinal Cord Injury 70
Hearing Impairment 72
Wheelchairs & Mobility Devices 72
Visual Impairment 73

Part VI – Equipment

Boats 75
Fixed Seats 80
Erg Adaptations 81
Custom Equipment 82
Pontoons 83
Strapping..... 84
Drop in rigs..... 86
Grip Aids 87
Seat Track Amendments 88
Oarlocks..... 89
Foot Adaptations 89
Padding..... 90
Seat Pads 91
Transfer Options 92
Communication Aids/ Software..... 94

Part VII – Programming & Volunteers

Programming 96
Volunteers 97
Tools - Sample Volunteer Application..... 99
Volunteer Training Checklist..... 97
Volunteer Recruitment 101
Volunteer Record Keeping..... 102

Part VIII – The IRS and Non Profit Status

Non Profit Certification Process 103
IRS 501c3 Guide..... 104

Part IX - Grant Writing

Grant Writing Guide 109
Grant Organizations..... 111

Part X – Adaptive Rigging & Technique

Rigging 116
US Adaptive Rigging Standards 118
Training 119
Adaptive Rowing Technique (AS) 120

Part XI – Research

FES Rowing 124

Part XII - Para-Rowing

Performance Pipeline..... 126
Adaptive Sample Initiative Workouts 128
Development Standards 130
Para-Rowing Resources 133
Sample - Training Schedules 134

Glossary of Rowing Terms 138

List of Suppliers 142

Introduction

What is Adaptive Rowing?

Adaptive rowing is the sport of sweep rowing or sculling for people with physical or intellectual impairments. An adaptive rower is a rower who requires modifications to equipment, coaching and program structure to allow for maximum functionality of the rowing stroke.

An adaptive rower may be a person who has, but is not limited to, Autism, limb amputation, joint limitations, blindness, visual impairment, paraplegia, quadriplegia, multiple sclerosis, cerebral palsy, spina bifida, Down syndrome, Post Traumatic Stress Disorder (PTSD), and Traumatic Brain Injury (TBI).

Para-rowing, a term coined by the International Paralympic Committee (IPC), defines participating athletes who have been classified by a FISA (World Rowing governing body) Medical and Technical Classifier and are placed into sport groups according to how much their physical impairment impacts the core functionality of the rowing stroke.

The purpose of this classification system is to minimize the impact that eligible impairment types have on the outcome of competition. FISA-sanctioned regattas require FISA-standard equipment to be used for competition.

More information on classification will be presented later in this guidebook, but the following link provides resources to learn about both athlete classification and how to become trained as a FISA Medical or Technical Classifier.

<http://www.worldrowing.com/para-rowing/>

Whether an adaptive athlete is rowing for recreation or is on the emerging-athlete pathway to the U.S. Paralympic Team, the integration of adaptive athletes into existing rowing programs benefits everyone involved.

Why Adaptive Rowing? Why Not?

Rowing provides similar benefits to all participants but can be particularly beneficial to people with disabilities. Participation in sports has been shown to enhance quality of life, encourages independence, wards off depression and increases self-esteem. USRowing recognizes that everyone deserves the same opportunities to participate in recreational and competitive rowing.

According to the May-August 2010 U.S. Census Bureau statistics, one in five people have a disability. Approximately 56.7 million people living in the United States had some kind of disability in 2010. This accounted for almost 19% of the 303.9 million people in the civilian, non-institutionalized population that year. Almost 13%, or 38 million people, had a severe disability.

What is a disability?

As defined by the U.S. Census Bureau, a difficulty or impairment is:

- 1. Hearing difficulty, deaf or having serious difficulty hearing*
- 2. Vision difficulty, blind or having serious difficulty seeing, even with glasses*
- 3. Cognitive/intellectual difficulty*
- 4. Ambulatory/mobility difficulty*
- 5. Self-care difficulty*
- 6. Independent living difficulty, because of a physical, mental, or emotional problem*

Wounded Military Veterans

USRowing has partnered with the U.S. Department of Veterans Affairs and other military support organizations like Wounded Warriors and Team Red, White and Blue to support our wounded veterans. The goal is to introduce the sport to more wounded veterans and create regular recreational, therapeutic and social opportunities for vets, with the additional goal of increasing the number of competitive veterans integrated with the national team and competitive club programs on the water.

According to a CRS communication from the Army Office of the Surgeon General January 10, 2014, the following data was released:

Annual New Post-Traumatic Stress Disorder Diagnoses in All Services, 2000-2014:

118,829

Traumatic Brain Injury (TBI) Combined, 2000-2013:

287,911

Individuals with Battle-Injury Major Limb Amputations, Combined, 2001-2013:

1,558

(Data source is the Defense Medical Surveillance System (DMSS). Author-Hannah Fischer, Information Research Specialist, hfischer@crs.loc.gov, 7-8989)

The characteristics of trained military personnel – commitment, teamwork, passion and a love of competition – are the same as successful Olympic and Paralympic athletes. USRowing’s goal is to introduce the sport to thousands of returning veterans and help some of those men and women to represent the U.S. in a uniform – on the water as part of the U.S. Para-Rowing Team.

Fighting Obesity

People with mobility, sight, hearing or intellectual disability issues may find it challenging to get enough exercise to maintain a healthy weight. Rowing provides a fun, efficient, and ideal opportunity for a person with a physical or mental impairment.

“Rowing involves use of a greater muscle mass than other sports, as a result of a larger involvement of leg muscles and the use of some larger arm and back muscles. Rowing, as compared to other aerobic exercises, ranks among the highest in terms of energy expenditure and aerobic demands. Only cross-country skiing is comparable to rowing in terms of intensity. Elite oarsmen can expend as many as 36 kcal/minute during a six-minute exercise, while the recreational rower can achieve between 2-24 kcal/minute.” - *Jan. 8, 1985 letter written to Arthur E. Martin (Alden Rowing Shell designer), from Frederick C. Hagerman, Prof & Chair Dept of Biomedical Sciences, Ohio University*

Whether a person participates in an indoor rowing program on an ergometer or is able to get out on the water in a boat, there are many reasons to row and benefits from the exercise of the rowing stroke.

BENEFITS OF ROWING

- ✓ Efficient cardiac workout and strengthening
- ✓ Full body muscular workout and strengthening
- ✓ Increased flexibility and maximum range of motion
- ✓ Efficient caloric output and weight control, important for those with mobility issues
- ✓ Non-impact sport – not hard on joints
- ✓ Emotions improve positively with increased endorphins from the exercise
- ✓ Improved immune system with increased exercise
- ✓ Improved memory and learning due to new cell creation
- ✓ Inclusion and social interaction
- ✓ Competition teaches teamwork and can benefit self-esteem
- ✓ Social interaction improves by interacting with others, camaraderie, friendship
- ✓ Nurturing one's spirituality
- ✓ Enjoy nature by being outdoors
- ✓ Fun! Being on the water, out of a wheelchair, or off support devices
- ✓ Independence and freedom (apparatus not visible or not in boat)
- ✓ Equality with able-bodied athletes on the water
- ✓ Personal satisfaction and joy in sharing the sport by coaching or volunteering

Additional unique benefits for the adaptive rower

- Can row without legs
- Don't have to see to row in a coxed boat
- Rowing can be done at a slow, steady rate
- Coxswain position requires minimal movement
- Rowing is done in a seated position
- The repetitive sequence of the rowing stroke has been shown to be beneficial in helping to recover from PTSD and TBI
- People with intellectual disabilities can master the repetitive stroke sequence

Club Benefits

- Offer membership to a more diverse range of people – new ideas
- Additional equipment to boost the club's existing fleet
- Media focus has potential of adding new members
- Opportunities for additional fundraising
- More members – share the administrative load
- Develop Paralympic rower



Paralympics – History of the Movement

Sport for athletes with impairment has existed for more than 100 years, and the first sport clubs for the deaf were already in existence in 1888 in Berlin.

It was not until after World War II, however, that it was widely introduced. The purpose of it at that time was to assist the large number of war veterans and civilians who had been injured during wartime.

At the request of the British government in 1944, Dr. Ludwig Guttmann opened a spinal injuries center at the Stoke Mandeville Hospital in Great Britain, and in time, rehabilitation sport evolved to recreational sport and then to competitive sport.

On July 29, 1948, the day of the Opening Ceremony of the 1948 Olympic Games in London, Dr. Guttmann organized the first competition for wheelchair athletes, which he named the Stoke Mandeville Games – a milestone in Paralympics history. They involved 16 injured servicemen and women who took part in archery. In 1952, Dutch ex-servicemen joined the movement and the International Stoke Mandeville Games were founded.

These later became the Paralympic Games, which first took place in Rome, Italy, in 1960 featuring 400 athletes from 23 countries. Since then, the Paralympics have taken place every four years. In 1976, the first Winter Games in Paralympic history were held in Sweden, and as with the Summer Games, have taken place every four years.

Since the 1988 Olympic Games in Seoul, South Korea, and 1992 Olympic Winter Games in Albertville, France, the Paralympics have taken part in the same cities and venues as the Olympics due to an agreement between the IPC and IOC.

Also in 1960, under the aegis of the World Federation of Ex-Servicemen, an International Working Group on Sport for the Disabled was set up to study the problems of sport for persons with an impairment. It resulted in the creation, in 1964, of the International Sport Organization for the Disabled (IOSD), who offered opportunities for those athletes who could not affiliate to the International Stoke Mandeville Games: visually impaired, amputees, persons with cerebral palsy and paraplegics.

At the start, 16 countries were affiliated to ISOD and the organization pushed very hard to include blind and amputee athletes into the 1976 Paralympics in Toronto and athletes with cerebral palsy in 1980 in Arnhem, The Netherlands. Its aim was to embrace all impairments in the future and to act as a co-coordinating committee. Nevertheless, other disability-orientated international organizations such as the Cerebral Palsy International Sports and Recreation Association (CPISRA) and International Blind Sports Federation (IBSA) were founded in 1978 and 1980.

The four international organizations experienced the need of coordinating the Games, so they created the "International Co-coordinating Committee Sports for the Disabled in the World" (ICC) in 1982.

The ICC was originally composed of the four presidents of CPISRA, IBSA, ISMGF and ISOD, the general secretaries and one additional member. (In the beginning, it was the vice president, and later on, the technical officer). The International Committee of Sport for the Deaf (CISS) and International Sports Federations for Persons with an Intellectual Disability (INAS-FID) joined in 1986, but the deaf still maintained their own organization. However, the member nations demanded more national and regional representation in the organization.

Finally on September 22, 1989, the International Paralympic Committee was founded as an international non-profit organization in Dusseldorf, Germany, to act as the global governing body of the Paralympic movement.

The word "Paralympic" derives from the Greek preposition "para" (beside or alongside) and the word "Olympic." Its meaning is that Paralympics are the parallel Games to the Olympics and illustrates how the two movements exist side-by-side.

<http://www.paralympic.org/the-ipc/history-of-the-movement>



The symbol of the Paralympic Games is composed of three "agitos", coloured red, blue and green, encircling a single point, on a white field. The agito ("I move" in Latin) is a symbol of movement in the shape of an asymmetrical crescent.

Timeline of Adaptive Rowing in the U.S.

(The following is an excerpt from the second edition of Rowing Faster (Human Kinetics, 2011), edited by Volker Nolte. This excerpt comes from Chapter 15, "Special Considerations for Adaptive Rowing," written by Karen M. Lewis.)

Athletic competition is segmented to provide a level playing field from the moment one enters the playground as a young person to the highest level of sport, the Olympic Games. Parity provides greater opportunity for athletes to achieve the peak level of human performance. Most sports have gender divisions, skill levels, age grouping and so on. In rowing, there are gender-separated races, lightweight divisions, masters events, and now there is an adaptive category for rowers with physical disabilities. Adaptive rowing refers to both the equipment adaptations for rowers with disabilities and the sport as a whole. Let us first look at the history of adaptive rowing.

History of Adaptive Rowing

Philadelphia was one of the birthplaces of adaptive rowing when veterans blinded in World War II competed in an Army-versus-Navy race. Over subsequent years, efforts were made to continue rowing programs for athletes with disabilities. For example, Ted Nash, an Olympic rower and coach for the University of Pennsylvania and Penn AC, worked to bring rowing to people with visual impairments. In 1980, Chris Blackwall, the executive director of USRowing, started the first U.S. rowing club solely for people with disabilities, the Philadelphia Rowing Program for the Disabled (PRPD). Other programs were starting up all over the world, and in 1993, adaptive rowing was included for the first time as an exhibition event at the FISA World Rowing Junior Championships in Finland and then again in 1999 at the World Rowing Championships in St. Catharines, Ontario.

In 2002, the FISA World Championships began to include adaptive rowing in the regular program. The sport gained momentum in 2005 when the International Paralympic Committee (IPC) voted to include adaptive rowing in the 2008 Paralympic Games in Beijing. Achieving this major milestone spurred the growth of adaptive rowing worldwide.

Timeline of Adaptive Rowing in the U.S.

- 1980: Philadelphia Adaptive Rowing (PAR) first adaptive rowing program in U.S.
- 1981: Bayada Regatta, United States' first and oldest adaptive regatta, held for the first time in Philadelphia
- 1993: Adaptive rowing was included for the first time as an exhibition event at the World Rowing Junior Championships in Finland

- 1999: Adaptive rowing included at the World Rowing Championships in St. Catharines, Ontario, Canada
- 2005: Para-Rowing introduced into the Paralympic program
- 2008: First Paralympic rowing events in Beijing
- 2010L C.R.A.S.H.-B. World Indoor Rowing Championships' first inclusion of adaptive rowing events – approximately 30 rowers
- 2012: Paralympic Games, 23 countries competed in London for 12 medals in four events with a total of 48 boats and 96 rowers
- 2013: C.R.A.S.H.-B. Championships includes almost 100 adaptive entries, including FES rowing
- 2013: Para-Rowing is practiced by athletes in at least 27 countries from five regions and continues to grow
- 2014: USRowing Adaptive Rowing programs number 50+ and growing

Programs are not alone in their quest. USRowing is here to support adaptive and para-rowing. USRowing is dedicated to providing the education that organizations need to develop their program. USRowing's inclusion and diversity initiative is called America Rows. USRowing encourages all adaptive programs to become America Rows affiliates and to take advantage of the many benefits affiliation has to offer.



Diversity – Brings people in. Inclusion – Keeps people in.

Is your rowing club an America Rows Affiliate?

OVERVIEW OF INCLUSION AND DIVERSITY

Mission/Vision

The mission of USRowing's America Rows program is to support inclusion and diversity in the sport of rowing. Inclusion in sport means that individual differences are embraced and respected. USRowing is passionate about recruiting and retaining the most skilled professionals and athletes, and recognizes that diversity will strengthen the sport of rowing.

America Rows also aims to increase awareness of rowing and create a national appreciation for the sport, in particular, highlighting its advantages for underrepresented youth, people with disabilities and people of all ages, socioeconomic circumstances and fitness levels.

The America Rows program is breaking down the barriers that have limited widespread public participation in rowing. In the world that we envision, when people think of rowing, they think of their local rowing center, high school, college or university, where people of all ages, economic, cultural, ethnic and demographic backgrounds participate. They recognize that rowing is a way to bring people with disabilities into the heart of their communities, to experience freedom on the water and to attain physical and mental fitness. They look forward to getting together with other rowers in their communities to erg, scull and sweep, to supporting rowing scholarships for deserving athletes and to cheering on local and national champions as they race all across the nation and globe.

History

Launched in 2010, America Rows is USRowing's fastest growing nation-wide initiative.

USRowing first broke major barriers in the 1970s following the passage of Title IX. After competitive rowing ceased to be dominated by Eastern schools, it was still male-dominated. It wasn't until 1972 with the passage of Title IX, which requires gender equity in every educational program receiving federal funding, that collegiate rowing programs for women surged. In the 1976 Olympics, women rowers were allowed to participate for the first time. The U.S. team, captained by Anita DeFrantz, the first African American woman medalist in the sport, returned from Montreal with a bronze medal in the women's eight. Nevertheless, it wasn't until 1997 that the NCAA established women's rowing as its 22nd championship sport.

That recognition opened a wellspring of college scholarships for women. Today, more than 7,750 women row their way to graduation, with the vast majority awarded scholarships to do so. U.S. women have become a powerhouse in international rowing competitions and the Olympics.

Building on the success with the inclusion of women, USRowing formed a Taskforce on Accessibility, Affordability and Diversity in 2006. The taskforce included representatives from all over the United States, as well as USRowing board members and staff, university and high school rowing coaches, community outreach rowing programs and world-class male and female rowers.

The role of the taskforce is to:

1. Provide internal and external guidance and assessment to the organization and membership.
2. Evangelize diversity and inclusion throughout USRowing's membership and organization.
3. Address the challenges, barriers and opportunities and implement nationwide strategic inclusion initiatives.

The taskforce held several nationwide diversity workshops. What became evident from the sessions was that a social class perception exists where many believe rowing to be a sport only for wealthy whites. This perception has created a barrier to entry for most Americans and even more so for the underserved urban youth. Also notable was the lack of underserved and economically disadvantaged youth at all levels of rowing. Additionally, there was the need to develop and expand programming for the diverse population with disabilities. To become more inclusive and increase the participation and awareness of rowing to America's underserved youth and people with disabilities, USRowing created America Rows.

Today, America Rows is a nationwide diversity and inclusion initiative aimed at increasing awareness of rowing and introducing the sport of rowing to a diverse group of Americans – specifically, the underserved urban, as well as rural, youth who otherwise may not have the opportunity to participate in rowing, as well as persons with physical and/or intellectual disabilities. America Rows programs provide rowing, personal development and a platform to help underrepresented youth and persons with disabilities.

Core goals of America Rows include:

1. Increase participation of underrepresented, economically disadvantaged youth and persons with disabilities.
2. Partner with other organizations and agencies to achieve the mission.
3. Educate and increase awareness of USRowing's diversity and inclusion mission.
4. Provide the resources that are necessary to create and support community outreach programs, as well as provide diversity programming.
5. Ensure that sustainable systems and structures are in place within the organization that foster inclusion throughout the rowing community.
6. Establish a fund to support diversity and inclusion initiatives.
7. Recruit, train and mentor racial and ethnic minority men and women to become rowing coaches.

Why commit to becoming an America Rows Affiliate?

America Rows is a public commitment by individuals and rowing organizations to take measurable steps to improve diversity and inclusion within the sport of rowing. Each organization will be able to set its own agenda, i.e. create a rowing community that reflects the diversity of their community.

America Rows affiliation will be renewed each year based on the organization supplying progress information that was established the previous year. All participating organizations will be permitted to use the America Rows logo on their website and printed materials.

America Rows Affiliate Program FAQ

What is America Rows?

America Rows, created in 2010, is a nationwide diversity and inclusion initiative aimed at increasing awareness of rowing and introducing the sport of rowing to a diverse group of Americans. Specifically, the program focuses on underserved urban and rural youth, who otherwise might not have the opportunity to participate in rowing, and persons with physical and intellectual disabilities. America Rows programs provide rowing, personal development and a platform to help underrepresented youth and persons with disabilities.

Opportunity to inspire cultural change within the sport of rowing

In order to reach as many potential rowers as possible and to spread the word and mission about America Rows, USRowing partners with USRowing member organizations. The partners are known as America Rows Affiliates, with the goal of 100% participation throughout USRowing's membership.

The Plan

Create a nationwide network of rowing programs that are committed to providing rowing opportunities to America's underserved youth and people with disabilities.

Who can become an America Rows Affiliate?

Any small or large for-profit or nonprofit rowing organization, school districts, universities, youth development agencies, parks and recreation departments, summer league programs, and medical and rehabilitative outpatient centers.

Why should an organization become an America Rows Affiliate?

As an affiliate, organizations can make a difference within their local community and the rowing community.

What are the benefits of partnering with USRowing? Organizations will:

- Become part of a national diversity and inclusion movement to diversify the sport of rowing.
- Gain increased public awareness and teach the community about rowing
- Provide rowing opportunities for youth who are economically disadvantaged and persons with disabilities.
- Help persons with mobility impairments, intellectual disabilities and urban and rural youth become more fit and combat the national obesity crisis.
- Gain support and diversity consultation from USRowing (to existing and emerging community outreach programs.)
- Increase ability to solicit funding in the community.
- Be mentioned in America Rows and USRowing's ongoing public relations and marketing campaign.
- Receive an America Rows promotional kit.

- Be able to participate in invitation-only diversity, inclusion and community outreach programs and events.
- Join hundreds of other rowing programs that have made a commitment to diversify rowing.

When can organizations use the name America Rows?

Organizations can use the America Rows name and logo once their completed application is verified or if they host an America Rows event. Some programs call themselves America Rows Saginaw, Austin, Cleveland, etc.

May sponsors fund local America Rows program?

Yes, America Rows Affiliates can solicit sponsorships, grants and foundation money.

Will an America Rows Affiliate be able to solicit funding from USRowing?

USRowing is not directly funding individual programs yet, but by participating in the first phase of America Rows, organizations will be eligible to apply for future grants and sponsorship when funding becomes available.

How can an organization get access to more information about America Rows?

For more information about America Rows, visit

<http://www.usrowing.org/domesticrowing/AmericaRows.aspx>.

Disability – What to say and how

What do I say? How do I learn how to coach an athlete with a disability? What can I ask?

The following documents proper use of disability language, and disability etiquette is the place start. But, what is most important is to **GET STARTED** – *just ASK!*

A Guide to Using Appropriate Language

Times have changed for people with disabilities...but language lags behind. Life for most people with mental or physical disabilities is vastly improved over what it was 20 or 30 years ago. The Americans with Disabilities Act, and other federal and state laws, assure that people with disabilities have the same basic rights as people without disabilities. Some things have been slower to change – namely, attitudes and perceptions about people with disabilities. Ignorance and discrimination can be serious impediments to achieving integration, productivity and independence for people with disabilities.

The use of outdated language and words to describe people with disabilities contributes greatly to perpetuating old stereotypes. People should no longer view individuals with disabilities as helpless or tragic victims. Awareness is the first step towards correcting this injustice. If public opinion about people with disabilities is to be brought up to date, the public needs to hear and learn to use appropriate language. It is especially important for the media, elected officials, public speakers and others in leadership positions to portray people with disabilities sensitively and realistically. This is a guide to using descriptive words and language when talking to or about people with disabilities.

Guidelines for Talking about Disability

1. Do not refer to a person's disability unless it is relevant.
2. Use "disability" rather than "handicap" to refer to a person's disability. It is okay to use "handicap" to describe accessibility accommodations, such as handicap parking, but it is better to use "accessible" in those instances. It also is okay to say that a person is handicapped by obstacles, such as architectural barriers or the attitudes or ignorance of insensitive people. Never use "cripple/crippled" in any reference of disability.
3. When referring to a person's disability, try to use "people first" language. In other words, it is better to say "person with a disability" or "man who has autism" rather than "a disabled person" or "an autistic man," particularly in a first reference.
4. Avoid referring to people with disabilities as "the disabled, the blind, the epileptics, the retarded, a quadriplegic," etc. Descriptive terms should be used as adjectives, not as nouns.
5. Avoid negative or sensational descriptions of a person's disability. Don't say, "suffers from," "a victim of," or "afflicted with." Don't refer to people with disabilities as "patients" unless they are receiving treatment in a medical facility.

Never say, "invalid." These portrayals elicit unwanted sympathy, or worse, pity toward individuals with disabilities. Respect and acceptance is what people with disabilities would rather have.

6. Don't portray people with disabilities as overly courageous, brave, special or superhuman. This implies that it is unusual for people with disabilities to have talents or skills.
7. Don't use "normal" to describe people who don't have disabilities. It is better to say "people without disabilities" or "typical," if necessary to make comparisons.
8. Never say, "wheelchair-bound" or "confined to a wheelchair." People who use mobility or adaptive equipment are, if anything, afforded freedom and access that otherwise would be denied them.
9. Never assume that a person with a communication disorder (speech impediment, hearing loss, motor impairment) also has a cognitive disability, such as mental retardation. On the other hand, people with mental retardation often speak well.

Rules for Appropriate Language

- Use the terms person with a disability, has a disability, people with disabilities, have disabilities.
- Avoid the terms: disabled person, the disabled, the handicapped, invalids, patients, crippled, deformed, or defective.
- Use the terms people without disabilities or typical person.
- Avoid the terms normal, healthy or able-bodied.
- Use the terms wheelchair user or uses a wheelchair.
- Avoid the terms wheelchair-bound or confined to a wheelchair.
- Use the terms congenital disability or birth anomaly.
- Avoid the terms birth defect or affliction.
- Use the terms has cerebral palsy (CP) or other condition.
- Avoid the term a victim of cerebral palsy.
- Use the terms has had polio, experienced polio or has a disability as a result of polio.
- Avoid the terms suffers from polio, afflicted with polio or post-polios (as a noun referring to people).
- Use the terms people who have mental retardation (MR) or person with mental retardation.
- Avoid the terms "the mentally retarded," mentally deficienta retardate, a retard (never), or a feeble-minded person.
- Use the terms child with a developmental delay (DD) or person with a developmental disability.
- Avoid the term slow.
- Use the term person with Down Syndrome. Avoid the terms the Down's person or Mongoloid (never).

- Use the terms person who has epilepsy, people with seizure disorders, seizure or epileptic episode or event.
- Avoid the terms the epileptic (to describe a person), the epileptic's fits or epileptic fits.
- Use the term people who have mental illness or person with a mental or emotional disorder.
- Avoid the terms the mentally ill, crazy, psycho or mental case (never).
- Use the terms people who are blind, visually impaired, person who is hard of hearing, person who is deaf or the Deaf. Deafness is a cultural phenomenon and should be capitalized in those instances.
- Avoid the terms the blind-hearing impaired (translates as "broken hearing" in sign language), deaf-mute or deaf and dumb.
- Use the term speech or communication disability.
- Avoid the term tongue-tied or mute.

(From <http://www.traponline.com/>: *Talking About Disability*)

Disability Etiquette

How to handle yourself when working with a person who has a disability

People with disabilities are entitled to the same courtesies extended to anyone, including personal privacy.

- If someone finds it inappropriate to ask people about their sex lives, complexions or incomes, then extend the courtesy to people with disabilities.
- Don't lean or hang on someone's wheelchair. Wheelchairs are an extension of personal space.
- When offering to assist someone with vision impairment, allow the person with vision impairment to take the assistant's arm. This will help the assistant guide the person, rather than propel or lead.
- Treat adults as adults. Call a person by his or her first name only when extending this familiarity to everyone present. Don't patronize people who use wheelchairs by patting them on the head. Reserve this sign of affection for children.

Disability Etiquette in conversation...

- When talking with someone who has a disability, speak directly to him or her, rather than through a companion who may be along.
- Relax. Don't be embarrassed if common expression, such as "See you later" or "I've got to run", that seem to relate to the person's disability is used.
- To get the attention of a person who has a hearing disability, tap the person on the shoulder or wave a hand. Look directly at the person and speak clearly, slowly and expressively to establish if the person can read lips. Not everyone with hearing impairments can lip-read. Those who do will rely on facial expressions and other body language to help understand. Show consideration by facing a light source and keeping hands and food away from the mouth when

speaking. Keep mustaches well trimmed. Shouting won't help, but written notes will.

- When talking with a person in a wheelchair for more than a few minutes, place oneself at the wheelchair user's eye level to spare both people a stiff neck.
- When greeting a person with a severe loss of vision, always identify yourself and everyone in the group. Say, for example, "On my right is Andy Clark." When conversing in a group, remember to give a vocal cue by saying the name of the person to whom you are speaking. Speak in a normal tone of voice, indicate when moving from one place to another and let it be known when the conversation is at an end.
- Give whole, unhurried attention when talking to a person who has difficulty speaking. Keep the manner encouraging rather than correcting, and be patient rather than speaking for the person. When necessary, ask questions that require short answers or a nod or shake of the head. Never pretend to understand if having difficulty doing so. Repeat what has been understood. The person's reaction will guide the understanding.

Common courtesies...

- When looking to help someone with a disability, ask if he or she needs it before acting, and listen to any instructions the person may want to give.
- When giving directions to a person in a wheelchair, consider distance, weather conditions and physical obstacles such as stairs, curbs and steep hills.
- When directing a person with a visual impairment, use specifics such as "left a hundred feet" or "right two yards".
- Be considerate of the extra time it might take a person with a disability to get things done or said. Let the person set the pace in walking and talking.
- When planning events involving persons with disabilities, consider their needs ahead of time. If an insurmountable barrier exists, let them know about it prior to the event.

(Easter Seals Disability Services (<http://www.easterseals.com/explore-resources/facts-about-disability/disability-etiquette.html>))

American Disability Act (ADA) Basics

The Americans with Disabilities Act (ADA) became law in July 1990. The law guarantees full participation in American society for all people with disabilities, just as the Civil Rights Act of 1964 guaranteed the rights of all people regardless of race, sex, national origin or religion.

The ADA covers every person with an impairment that substantially limits one or more major life activities. Title I of the ADA prohibits private employers, state and local governments, employment agencies and labor unions from discriminating against qualified individuals with disabilities in job application procedures, hiring, firing, advancement, compensation, job training and other terms, conditions and privileges of employment.

An individual with a disability is a person who:

Has a physical or mental impairment that substantially limits one or more major life activities; has a record of such an impairment; or is regarded as having such an impairment. A qualified employee or applicant with a disability is an individual who, with or without reasonable accommodation, can perform the essential functions of the job in question.

Reasonable accommodation may include, but is not limited to: Making existing facilities used by employees readily accessible to and usable by persons with disabilities; job restructuring, modifying work schedules, reassignment to a vacant position; acquiring or modifying equipment or devices, adjusting modifying examinations, training materials, or policies and providing qualified readers or interpreters.

An employer is required to make an accommodation to the known disability of a qualified applicant or employee if it would not impose an "undue hardship" on the operation of the employer's business. Undue hardship is defined as an action requiring significant difficulty or expense when considered in light of factors such as an employer's size, financial resources and the nature and structure of its operation.

An employer is not required to lower quality or production standards to make an accommodation, nor is an employer obligated to provide personal use items such as glasses or hearing aids.

Employers may not ask job applicants about the existence, nature or severity of a disability. Applicants may be asked about their ability to perform specific job functions. A job offer may be conditioned on the results of a medical examination, but only if the examination is required for all entering employees in similar jobs. Medical examinations of employees must be job related and consistent with the employer's business needs.

Employees and applicants currently engaging in the illegal use of drugs are not covered by the ADA, when an employer acts on the basis of such use. Tests for illegal drugs are not subject to the ADA's restrictions on medical examinations. Employers may hold illegal drug users and alcoholics to the same performance standards as other employees.

Title II of the ADA prohibits discrimination against qualified individuals with disabilities in all programs, activities, and services of public entities. It applies to all state and local governments, their departments and agencies and any other instrumentalities or special purpose districts of State or local governments.

Title III of the ADA prohibits discrimination on the basis of disability by "private entities" operating places of "public accommodation." Businesses governed by Title III include banks, restaurants, supermarkets, hotels, shopping centers, privately-owned sports arenas, movie theaters, private day care centers, schools and colleges, accountant or insurance offices, lawyers' and doctors' offices, museums and health clubs.

Sources: The U.S. Equal Employment Opportunity Commission, The U.S. Department of Justice
<http://www.fcc.gov/cgb/dro/>

Federal Communications Commission (FCC): Disability Rights Office

The Federal Communications Commission offers technical assistance on ADA telephone relay service requirements: <http://www.adata.org/>.

National Institute on Disability and Rehabilitation

The National Institute on Disability and Rehabilitation provides information regarding technical assistance programs: <http://www.access-board.gov/adaag/about/>.

Access Board

The U.S. Access Board: <http://www.access-board.gov/>

Source: The Christopher & Dana Reeve Foundation Paralysis Resource Center website:
http://www.christopherreeve.org/site/c.mtKZKqMWKwG/b.4467341/k.9A6B/Basics_of_the_ADA.htm
technical assistance on the ADA Accessibility Guidelines.

What is an Adaptive Rowing Program?

An adaptive rowing program is as simple as one advocate/coach who is willing to work with one adaptive athlete.

ROWER + ADVOCATE/COACH = Adaptive Rowing Program

1 : 1 : 1

Adaptive programming can take many forms, and below are examples of the different kinds that currently exist in the U.S.

- Para-Rowing
- FES (Functional Electrical Stimulus)
- Recreational Adaptive
- Cancer Survivor Group
- Erg/On Land Only (stoma)
- Autistic Group
- Hearing Impaired
- Visually Impaired
- Physically Disabled
- Intellectually Disabled
- Veterans – i.e. Wounded Warriors
- Specialized Camps
- One-time Events
- Volunteer Training
- Coach Training
- OR Combined Sessions

An adaptive rowing program may be focused on one or a combination of these programs, each uniquely different and as special as the people with whom the program works. There is an opportunity to help create an extraordinary experience for both the participants and the volunteers and to make a positive impact in the community.

Classification for Para-Rowing

Classification is the process by which an athlete is evaluated for a physical disability by a certified FISA Medical or Technical Classifier and placed into a para-rower sport class according to how much their impairment impacts on the core determinants of success in rowing. The purpose of classification is to group rowers of similar levels of functional ability to insure competition is as fair as possible.

Is classification required to participate in adaptive rowing? No.

When is classification required? When it benefits the athlete.

If an athlete is participating in either a FISA-sanctioned competition or a competition where FISA rules are used as guidelines or enforced, he or she will need to be classified and will be required to use FISA-standards equipment and compete by FISA rules.

Additional reasons to use the different classification groups:

- Helps coaches plan for practices, training and equipment needs
- Provides structure for practice and competition
- Determines eligibility of athletes (permanent and verifiable limitation)
- Minimizes effect of impairment on competition
- Maximizes inclusion
- Qualifies athletes to compete at FISA events and Paralympic Games

Classification Process

After meeting the prerequisites for a classification session, the process involves four parts:

1. Bench Test – performed by a FISA Medical Classifier with FISA Technical Classifier in attendance.
2. Ergometer Test – performed by a FISA Technical Classifier with FISA Medical Classifier in attendance.
3. On-Water Observation – performed by both a FISA Medical Classifier and a FISA Technical Classifier and conducted during training and/or competition, based on results of the Bench and Erg Test.
4. Medical Evaluation – performed by both classifiers to assess functional range of motion, strength or coordination.

FISA Sport Classes

Classification determines eligibility of the athlete in four (4) sport classes:

- **Leg, Trunk & Arms (LTA)**
- **Trunk & Arms (TA)**
- **Arms & Shoulders (AS)**
- **Not Eligible to Compete (N/E)**

Legs, Trunk and Arms Additional Subgroups

The LTA class incorporates five specific categories that relate to three disability groups:

- **LTA-PD** – Leg, trunk, arms, physical disability
- **LTA-B1, LTA-B2, LTA-B3** – Leg, trunk, arms, visual impairment
- **LTA-ID** – Leg, trunk, arms, intellectual disability

Note: LTA-ID (Intellectual disability) is not currently a FISA classification. FISA is currently working on an evidence-based classification test for possible inclusion of rowers with an intellectual disability into the Paralympic Games.

Additional things to know about the testing procedure:

- Classification tests for strength, flexibility, coordination and ability to perform **rowing-specific** function only (not running, walking, swimming, basketball, or other activities.)
- A rower must be tested with and without their prosthesis (artificial device that replaces a body part) or orthosis (support/correctional device) and is issued the more functional class.
- It is OK to row UP but not down. In other words, a rower classified as TA may compete in LTA, but not AS.
- Always keep in mind what's best for the athlete – training UP and maximizing functionality.

The Spinal Column Basics

A diagram of the spinal column is included to help guide you through some of the descriptions listed further on in the classification criteria.

A person with a spinal cord injury (lesion) may be a paraplegic or a quadriplegic. When a spinal cord injury occurs, the level is designated (e.g. C-4 quadriplegia). Paraplegia results from injury at the T-1 (thoracic) level or below, and quadriplegia results from injury at the C-8 (cervical) level or above.

Neurological damage may be COMPLETE with no sensation or movement, or it may be INCOMPLETE with varying degrees of sensation or motion.

If the lesion is COMPLETE, the following applies:

- C-6 to C-8: impairment of hand and lower arm use. Some people may be able to grasp the oar, but not have full hand motion.
- T-6: muscles below the nipple line are affected.
- T-8 and above: eliminates most balance while sitting
- T-9 to T-12: eliminates abdominal muscles for rotating the trunk and forward flexion of the trunk. Loss of some abdominal muscles also affects balance.
- Lumbar and sacral lesions affect leg muscles and torso, and balance remains intact.

If the lesion is INCOMPLETE, these effects will vary with the individual.

Anatomy of the Spinal Cord

The spinal cord consists of nerves that connect the brain to nerves in the body. It is a superhighway for messages between the brain and the rest of the body. The spinal cord is surrounded for most of its length by the bones (vertebrae) that form the spine. There are:

- Seven cervical vertebrae (these are in the neck and are red in the diagram; they are numbered from top to bottom);
- 12 thoracic vertebrae (these are in the trunk and are green in the diagram);
- Five lumbar vertebrae (these are in the lower back and are purple in the diagram);
- Five sacral vertebrae (these are in the pelvis and are yellow in the diagram; they are ordinarily fused together); and
- Four fused vertebrae that form the coccyx.

There are 31 pairs of spinal nerves that connect with the spinal cord through nerve roots and travel to specific parts of

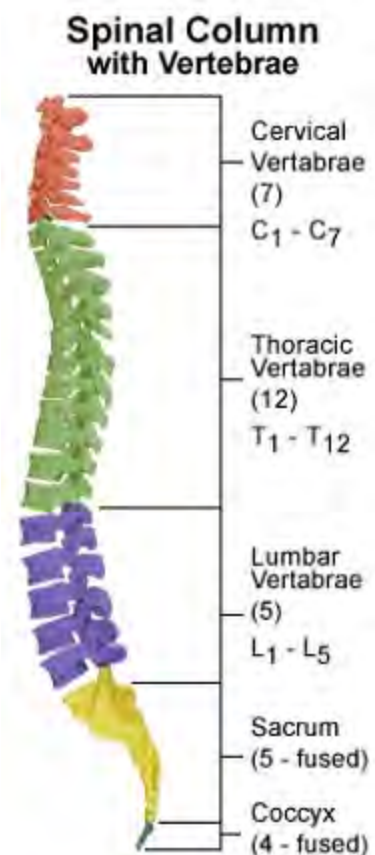

the body. For example, the pair of spinal nerves connecting with the spinal cord in the region of the C-2 vertebra travel to the head and neck, while the spinal nerves attaching to the cord in the region of the L-4 vertebra run to specific muscles in the legs and specific areas of skin in the calves. The diagram below indicates where in the body the spinal cord nerves extend.

(<http://www.sci-recovery.org/sci.htm>)

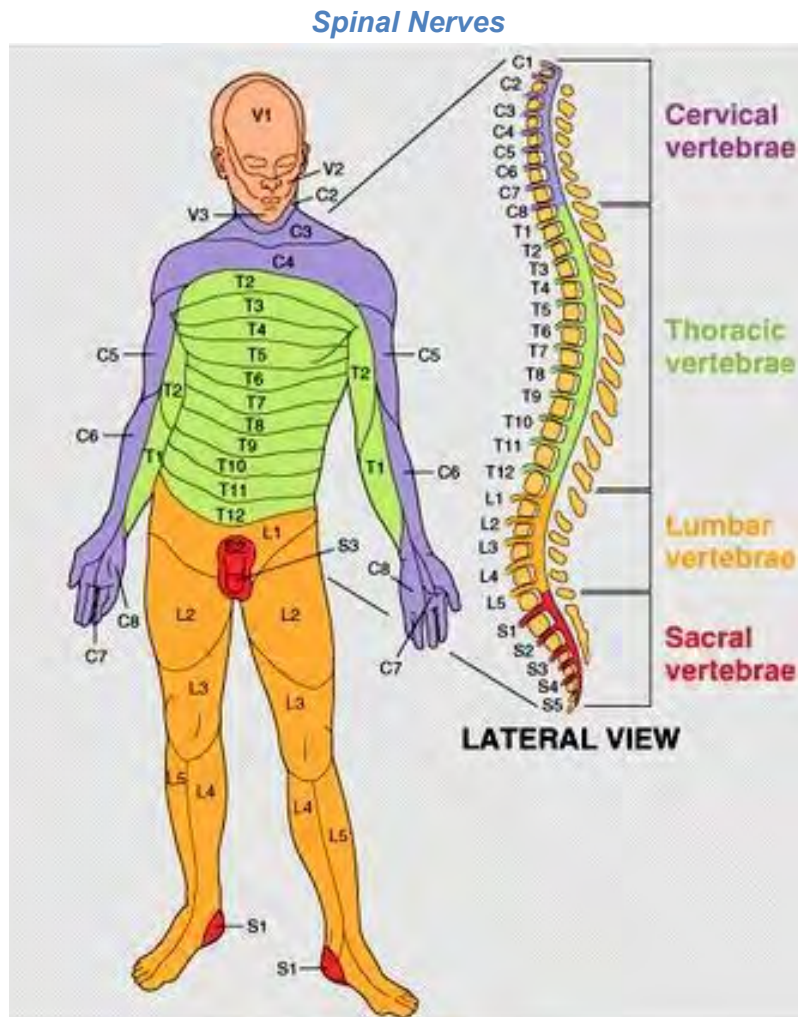

Classification – Legs, Trunk, Arms (LTA) Class

Typical Characteristics of a LTA rower:

- Amputation: minimum of one single foot, trans metatarsal or three fingers of one hand
- Neurological impairment equal to incomplete lesion at S-1
- Cerebral Palsy Class 8 (CP-ISRA)
- Visual Impairment: IBSA Classification (LTA-VI)
- One neurological impairment of single arm

The LTA rower can support oneself on the sliding seat.

TEST: Can the athlete perform a full squat and return to a full standing position? If so, the rower will probably be assigned a LTA classification.



LTA-VI (Legs, Trunk, Arms - Visually Impaired)

Ophthalmologist or Optometrist certification of:

- B1 – No light perception in either eye to light perception, but inability to recognize the shape of a hand at any distance or in any direction.
- B2 – From ability to recognize the shape of a hand to a visual acuity of 2/60 and/or monocular visual field of more than five degrees and less than 20 degrees.
- B3 – From visual acuity about 2/60 to visual acuity of 6/60 and/or monocular visual field of more than five degrees and less than 20 degrees.
- N/E – visual acuity over 6/60 and/or monocular visual field of more than 20 degrees.

All testing is done with best eye correction or with lenses, if used. Prior to international FISA competition, the VI athlete must be classified by an International Blind Sports Association (IBSA) Classifier, which can take place just prior to the event.



LTA Equipment Considerations

- Boat, oars and rigging are the same as non-adaptive 4+ and 2x (Worlds)
- Exception – goggles for visually impaired rowers



- The LTA-VI rower must wear light occluding goggles during warm-up, training and competition, if racing under FISA rules.

CLASSIFICATION – Trunk and Arms (TA) Class

- Rower has trunk function
- Rower is unable to use sliding seat to propel boat
- Rower has significantly weakened function and movement of the lower extremities

Typical characteristics of a TA rower: have a minimum disability equivalent to at least:

- A bilateral around knee amputation
- A significantly impaired quadriceps
- A neurological impairment equivalent to a complete lesion at L-3 (lumbar) level
- A neurological impairment equivalent to an incomplete lesion at L-1
- A combination of the above
- A classification for a rower with Cerebral Palsy Class 5 (CPISRA)

TEST: Can the athlete pivot from hip and lean forward and return to the upright position unassisted? If so, the rower would probably receive a TA classification





TA Equipment Considerations

- Fixed seat
- Knee strap (required over thigh as close to the knee as possible)
- Lap/hip strap
- Seat back may be removed
- Rigger with reduced span and deeper chevron (thru-the-pin)
- Shorter inboard oars
- Pontoons optional

CLASSIFICATION – Arms and Shoulders (AS) Class

- Rower has minimal to no trunk function
- Rower is able to apply force using predominantly the arms and shoulders
- Rower has decreased sitting balance usually present

An AS rower may typically have a minimum disability equivalent to at least one of the following:

- Neurological impairment equal to complete lesion at T-12 (thoracic)
- Neurological impairment equal to incomplete lesion at T-10 (thoracic)
- Cerebral Palsy Class 4 (CP-ISRA)



Equipment Considerations for AS Rower

- Fixed seat
- Chest strap (required)
- Knee strap (required) over thighs as close to the knee as possible
- Pontoons (required) just touching the water
- Narrow span/deeper chevron rigger
- Shorter oars (no overlap)
- Blades fixed in the “feather” position if grip issue

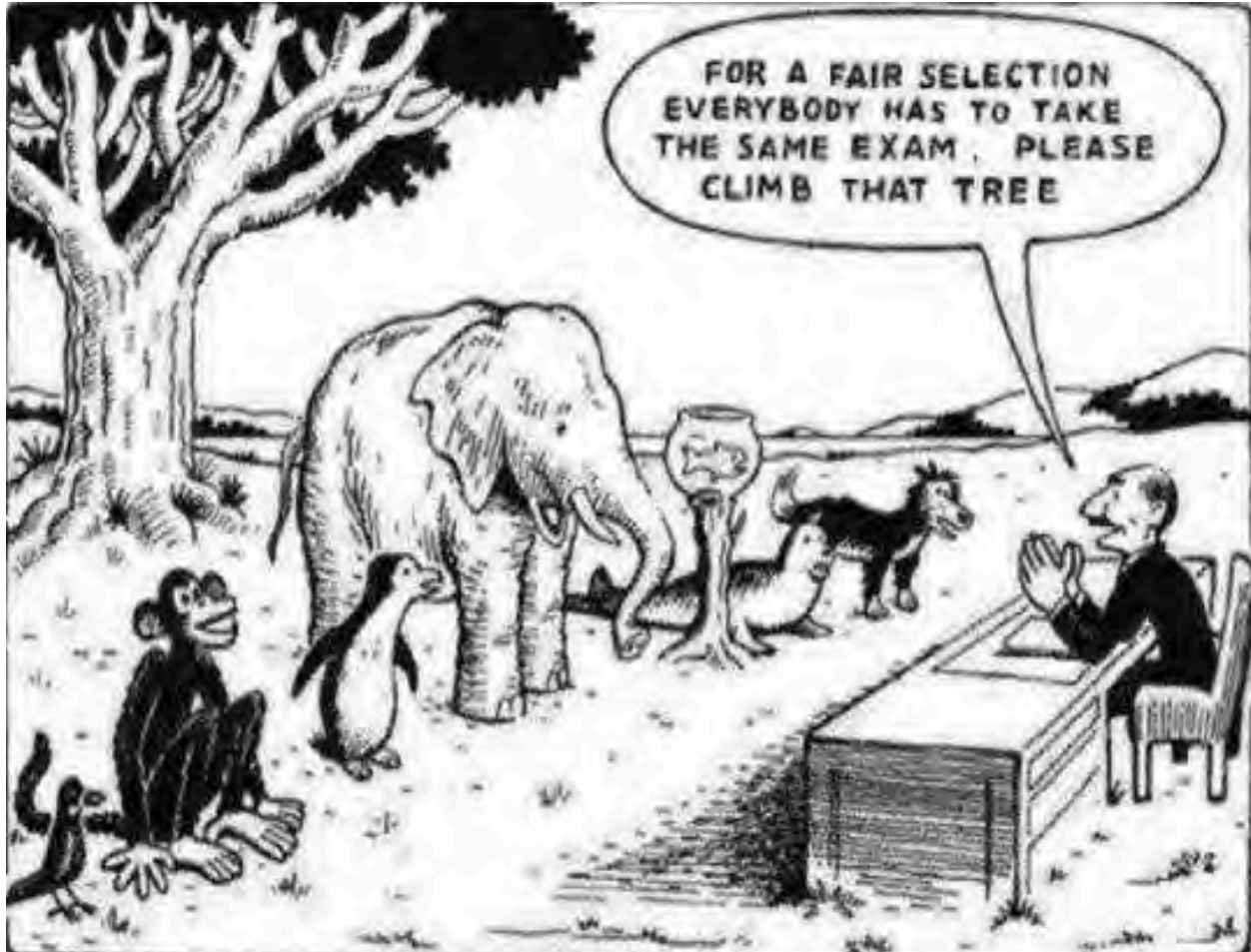

Emphasize Abilities, Not Limitations

“NORMAL”

is a dryer setting!



What is FISA, the International Rowing Federation?

The World Rowing Federation, FISA, from the French Fédération Internationale des Sociétés d’Aviron, is the governing body of the sport of rowing. It is empowered by its 142 member National Rowing Federations, the National Olympic Committees and the International Olympic Committee to govern the sport of rowing.

FISA sets the rules and regulations for the practice of the sport, in all its forms, including elite, para-rowing, coastal, masters and aspects of indoor rowing. FISA oversees sanctioned world rowing events and provides advice and expertise for the organization of rowing regattas. The federation also works on coaching education and other matters relating to the sport and its development.

Link to FISA Website

<http://www.worldrowing.com/para-rowing/>

Para-Rowing Classification Paperwork

[2014 Para-rowing classification paperwork](#)

Para-Rowing Event Regulations and/or Departures from the FISA Rules of Racing

[Appendix 13 Event Regulations and/or Departures from FISA Rules of Racing](#)

[Para-Rowing Classification Regulations](#)

VI Medical Form

[VI medical form](#)

FISA Medical Diagnostic Form

[FISA Medical Diagnostic Form](#)

Para-Rowing Events

If you are familiar with the nomenclature given to assign boat events, the following are the five events currently included for para-rowing at the Paralympics and world championships. Races are held over 1,000 meters for all five events, and the LTA and TA are mixed-gender boats. Adaptive rowing is a relatively young sport and does not include as many classes currently as other adaptive sports.

- 1) **LTA Mix4+**
- 2) **LTA Mix2x (World Championships Only)**
- 3) **TA Mix2x**
- 4) **AS W1x**
- 5) **AS M1x**



Non-Para Rowing Events

Most regattas in the U.S. make an effort to include as many events as possible. The goal is to include a variety of disability classifications, while still having enough participants having the same sports class to have an event. Races can vary in length – three-mile head races to shorter 500-meter or 250-meter sprint races. Not every rower is able to complete a racecourse on their own and may need support from a non-adaptive partner to include them in a competitive experience.

Some visually impaired (VI) rowers are able to successfully complete a sprint course by following a guide boat, while a hearing impaired (HI) rower needs only a physical or visual clue to know when to start, stop or turn. Athletes with intellectual disabilities (ID) are participating at an ever-growing number, and although not included yet within the FISA classification system, can and should be included at every opportunity.

The goal is to get as many adaptive rowers participating as possible. If your program sponsors a military adaptive program, you might consider adding an event for military participants. Some wounded veteran trunk and arms (TA) events are further split into categories where those with leg amputations row in a separate event from those with a single arm amputation – without any further restrictions.

Below is a list of suggested categories you might consider adding to your next boat or erg race:

- LTA Mix 8+, LTA-VI 8+, LTA-ID 8+, LTA Mix Military (PTSD, TBI) 8+
- LTA M4+, LTA W4+, LTA-ID 4+
- LTA 1x, TA 1x
- LTA-ID Mix Adapt/Non-Adapt 2x
- TA Mix Adapt/Non-Adapt 2x

- TA-1x
- AS-VI 1x w/guide
- AS- 2x



ESTIMATING EVENT TIMES

Enough data has been collected from the pool of adaptive rowers competing at the C.R.A.S.H.-B. World Indoor Rowing Championships to know one can expect the following adaptive events to complete their race from shortest to longest amount of time:

- LTA-VI
- LTA- PD (Might include amputation of single arm or below knee, MS)
- LTA-ID
- TA
- LTA-AK (above knee amputation)
- AS

This information is important when planning race centers (the time it takes to row to the start, start, complete the event and start the next event.)

COMBINED EVENT RACING

If there are limited entries and rowers from different sport classes will compete together, time handicaps can be applied for the 1,000m race. A TA men's 2x could race an ASW1x or a LTAM1x, etc., if the time handicapping system is applied.

Please refer to this chart for the suggested handicaps.

1,000-meter Adaptive Race Time Handicap in Seconds

Legs, Trunk, and Arms Men's Double Sculls	LTAM2x	0.0
Legs, Trunk, and Arms Mixed Double Sculls	LTAMix2x	9.5
Legs, Trunk, and Arms Mixed Coxed Four	LTAMix4+	10.1
Legs, Trunk, and Arms Men's Single Sculls	LTAM1x	16.2
Legs, Trunk, and Arms/Trunk and Arms Men's Double Sculls	LTA/TA M2x	18.7
Legs, Trunk, and Arms Women's Double Sculls	LTAW2x	19.1
Legs, Trunk, and Arms/Trunk and Arms Mixed Double Sculls	LTAM/TAW Mix2x	28.3
Legs, Trunk, and Arms/Trunk and Arms Mixed Double Sculls	LTAW/TAM Mix2x	30.0
Legs, Trunk, and Arms Women's Single Sculls	LTAW1x	34.6
Legs, Trunk, and Arms/Arms, Shoulders Men's Double Sculls	LTA/AS M2x	37.0
Trunk and Arms Men's Double Sculls	TAM2x	37.4
Legs, Trunk, and Arms/Trunk and Arms Women's Double Sculls	LTA/TA W2x	39.6
Legs, Trunk, and Arms/Arms, Shoulders Mixed Double Sculls	LTAM/ASW Mix2x	46.7
Trunk and Arms Mixed Double Sculls	TAMix2x	48.8
Legs, Trunk, and Arms/Arms, Shoulders Mixed Double Sculls	LTAW/ASM Mix2x	53.8
Trunk and Arms/Arms, Shoulders Men's Double Sculls	TA/AS M2x	55.7
Trunk and Arms Men's Single Sculls	TAM1x	56.7
Trunk and Arms Women's Double Sculls	TAW2x	60.1
Legs, Trunk, and Arms/Arms, Shoulders Women's Double Sculls	LTA/AS W2x	63.6
Trunk and Arms/Arms, Shoulders Mixed Double Sculls	TAM/ASW Mix2x	67.1
Trunk and Arms/Arms, Shoulders Mixed Double Sculls	TAW/ASM Mix2x	72.6
Arms, Shoulders Men's Double Sculls	ASM2x	74.0
Trunk and Arms Women's Single Sculls	TAW1x	78.7
Trunk and Arms/Arms, Shoulders Women's Double Sculls	TA/AS W2x	84.1
Arms, Shoulders Mixed Double Sculls	ASMix2x	91.0
Arms, Shoulders Men's Single Sculls	ASM1x	96.3
Arms, Shoulders Women's Double Sculls	ASW2x	108.0
Arms, Shoulders Women's Single Sculls	ASW1x	130.0



REFEREE GUIDELINES FOR PARA-ROWING

USRowing Rules of Rowing are currently addressing differences for para-rowing. In the absence of domestic guidelines, the FISA procedures and event regulations are typically adopted. However, it is common for additional boat classes not included in the FISA para-rowing program to be included at domestic regattas, which requires some adaptations.

Rowers should have gone through the classification process to receive a sport class and eligibility to compete in para-rowing. For some regattas, the classification is achieved through self-classification on the competitor's honor. A list of U.S. classified para-rowing athletes and their assigned sport classes is available from the adaptive rowing section of the USRowing website at

<http://www.usrowing.org/NationalTeams/ParalympicParaRowingNationalTeam/ParaRowingClassification.aspx>.

FISA Classification – Standard 1,000-meter Course

LTA Mix 4+ (Leg-Trunk-Arms)

- *Crew:* 2 men, 2 women, maximum 2 visual impaired (VI) with classification LTA-B3
- *Equipment considerations:* VI rowers wear light occluding goggles while on water during training, warm-up, cool down and competition from opening day until completion of the final race of competition.
- *Minimum boat weight:* 51 kg

LTA Mix 2x (World Championships Only)

- *Crew:* 1 man, 1 woman, maximum 1 VI of either LTA-B1 or LTA-B2
- *Equipment considerations:* VI rowers wear light occluding goggles while on water during training, warm-up, cool down and competition from opening day until completion of the final race of competition.
- *Minimum boat weight:* 27 kg

TA Mix 2x (Trunk & Arms)

- *Crew:* 1 man, 1 woman
- *Equipment considerations:* Fixed seat, pontoons optional, knee strap required
- *Minimum boat weight:* 37 kg

AS M1x/W1x (Arms & Shoulders)

- *Crew:* 1 man (M1x) or 1 woman (W1x)
- *Equipment considerations:* Fixed seat, pontoons required, knee strap required, chest strap required
- *Minimum boat weight:* 24 kg

The following are some additional considerations or duties for the referees, as it pertains to para-rowing.

Chief Referee / LOC Pre-Regatta Planning

- Traffic pattern separation for fixed-seat crews from all other crews.
- Additional safety boats, if needed, at shorter distance intervals.
 - Especially for hot/cold weather or head races.
- Consider additional safety crews (lifeguards) with swim goggles ready for strapped in rowers.
- Accessibility of docks, launching areas, boat storage areas and sanitary facilities for athletes in wheelchairs, assisted by guide dogs or other authorized caregivers.
- Weather rules that preclude novice boats from racing should also apply to para-rowing, fixed-seat boats.
- Additional time and space may be needed for para-rowing competitors on the launch and retrieval docks and to row from the docks to the start area.
- Second finish or start line with proper staffing and equipment if the para-rowing races are contested over a different race length than other races.
- Sufficient race centers to account for longer time required for fixed seat races (TA, AS).

Control Commission

- Additional items to check as competitors launch.
 - Compliance of boats with standard para-rowing boat specifications.
 - No restrictions on seat or rigger design.
 - Foot stretcher optional for TA and AS.
 - Safety measures in fixed seat boats including foot stretchers and strapping.
 - Fixed seat attached to seat deck at 30cm.
 - Backrest 2cm maximum thickness.
 - Correct placement and height of pontoons on AS1x boats.
 - Minimum just touch water when rower is seated and the boat is balanced.
 - Attached to riggers at a minimum distance of 60cm from the centerline of the pontoon to centerline of the boat.
 - Correct use of eyewear by visually impaired rowers.
 - Correct strapping of rowers in fixed-seat sport classes.
 - Quick release with color contrast safety tabs oriented same side.
 - Chest strap: point at which the strap is attached to the seat shall be no lower than the top edge of the supportive portion of the strap at the front of the torso, tight enough to restrict trunk movement while not restricting breathing.
 - Seat back: supportive portion of the backrest of the seat must not be lower than the level of attachment point for the front strap.
 - Grip aids and orthotics may be used but must release immediately by quick mouth action or other hand.
 - Additional padding and strapping is allowed above the minimums to support legs or torso.
- Check for accessibility of docks and launching areas for all para-rowing competitors.

- Allow for enough time and space for competitors and designated assistants to safely complete the compliance checks and launch.

Start Marshal

- Correct strapping of rowers in fixed-seat sport classes: Visually check as competitors approach the start area and advise competitor to make any adjustments, if needed.

Starter

- For LTA events, or other events specifically including visually impaired athletes, verbal announcement of the red flag or red light at the start.

Chase Referee

- Correct strapping of rowers in fixed-seat sport classes. (Ideally, any issues will have been observed and adjustments made prior to launching and rechecked visually in the marshal area before the start.)
- For LTA events, or other events specifically including visually impaired athletes, verbal announcement of the white flag or red flag shown to competitors at the finish.
- Protests may be lodged verbally to the referee from a competitor if their hands are strapped.

All Safety Boats and Referees on the Water

- Fixed-seat competitors are strapped to the boat and would need immediate assistance if a problem arises. Safety boats may need to be spaced more closely than for other competitors to decrease the response time.
- Understand that some para-rowing competitors may not float as expected. For instance, many double leg amputees float head down, requiring faster response time than for athletes whose head remains above water when floating.
- Remember that the competitors may not need assistance. If there is no imminent danger, talk with them first before rendering assistance to get back into their boat. Some may wish to get back in and continue to race, which is not permitted if outside assistance is given.
- Some para-rowing competitors may have issues with temperature regulation. In excessively warm, humid or cool temperatures, keep a close eye on athletes for signs of distress.

PROGRAMMING

How to get started?

The goal of any program should be to plan for long-term success by starting small and slowly building the program as it develops.

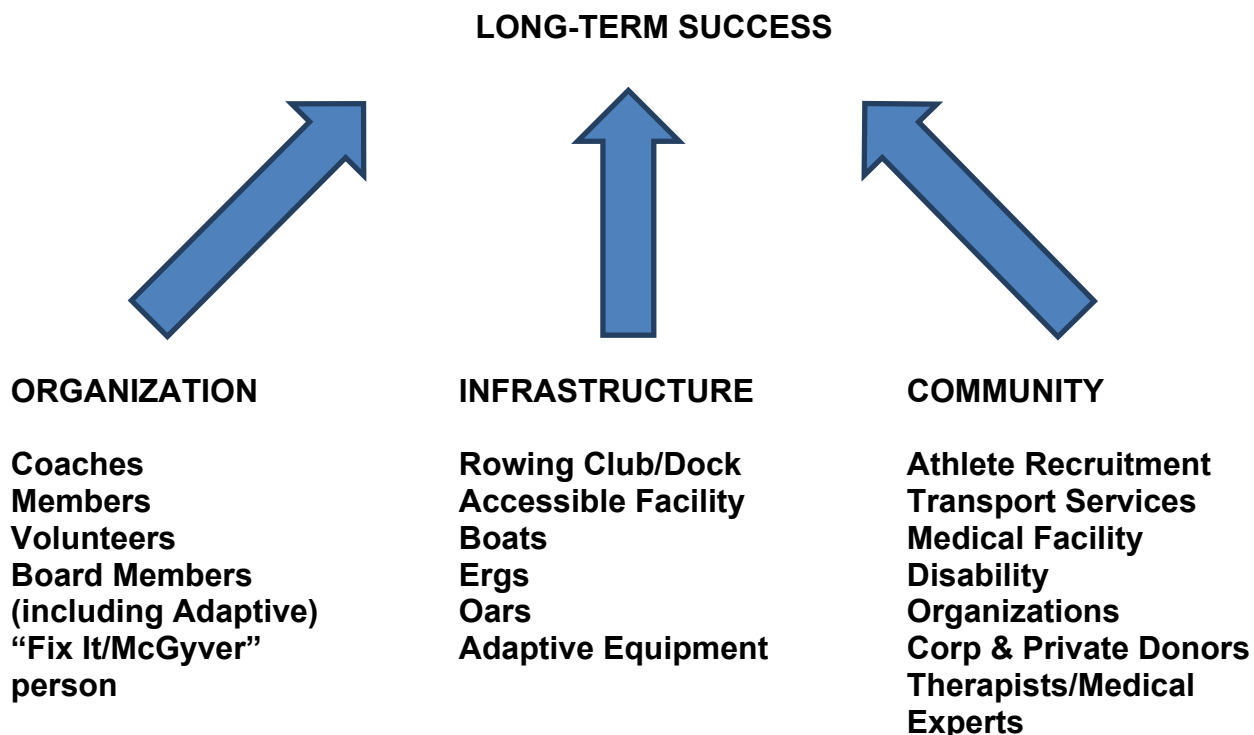

Collaboration between the primary rowing organization and the community is key in sustaining a viable adaptive rowing program for the long haul.

Initially, a program may be started by a few members of the rowing organization that are passionate about adaptive rowing and begin with a small number of athletes who they know or have approached the program. This is enough to launch the program, but eventually, the program needs to establish outreach programs into the community to include all populations and to recruit athletes from various sources.

During the initial planning stages, the program should include a wide scope of expertise from all involved including:

- Organization president
- Treasurer
- Board members, including adaptive members
- Outreach director
- Coaches
- Rigger
- Development and marketing officers

- Collaborative partners from the community – VA medical facility, rehab outpatient facility or local adaptive sport organization

The potential benefits of a collaboration between organizations, or even within an organization are:

- Continual athlete recruitment stream to sustain the program
- Additional financial support
- Broader marketing of the program
- Expertise from people in a given field (i.e. physical therapists, doctors, etc.)
- Volunteers/support staff who may accompany the adaptive athlete on site
- Larger cross section of the population, who bring myriad backgrounds to the project, boosting the levels of creativity and cultural influences

Facility Accessibility

Many USRowing organizations have the good fortune to have facilities that are new and completely accessible by disabled persons, while other older or multi-use buildings are only partially accessible or not accessible at all. Part of the process of planning for an adaptive rowing program involves a facility assessment in regards to accessibility.

Organizations may be concerned about the prohibitive cost of altering an existing facility to meet ADA requirements. Many ask, “Does our program facility have to meet all ADA requirements?” No. Title II of the ADA requires that a public entity make its programs accessible to people with disabilities, not necessarily each facility or part of a facility, especially if it puts undue burden on the program to the point that it sacrifices the program itself. New construction or amendments may require adherence to ADA guidelines. Architects are trained in ADA regulation, and there are many accessibility businesses that can be contacted to help with accessibility questions and issues. For more information on ADA requirements, please contact the local city and state governments and the ADA.gov site. A link to the U.S. 2010 ADA building standards can be found here: <http://www.ada.gov>.

The following two-page checklist can help in planning for immediate and future amendments that a facility may require. It doesn't cover all aspects of what a specific program may need, so be sure a planning committee discusses all areas. Better yet, take a couple of adaptive rowers on a complete tour of the facilities and take note of the special issues they might identify when accessing the club, dock or facility. Just because the boathouse has a “handicap” door doesn't mean it is functioning properly.

CHECKLIST – FACILITY ASSESSMENT FOR ADAPTIVE ROWING

	APPROACH	N/A	YES	NO	ACTION
1	Club accessible by public transport?				
2	Club within walking distance of public transport?				
3	Accessible transport services available?				
4	Bus Routes have low floor access ramps for wheelchair users?				
	PARKING				
5	Accessible parking for wheelchair users?				
6	Parking spaces close to the boathouse?				
7	Sufficient dedicated accessible parking spaces provided?				
8	Accessible parking clearly marked?				
9	Accessible parking good condition and level for wheelchair users?				
10	Parking safe with good lighting?				
11	Enough space in parking bays for adequate transfer space?				
12	Designated safe drop-off and pick-up locations?				
	STEPS				
13	Are there steps?				
14	Steps of proper dimensions?				
15	Steps have tactile surface for advanced warning in level changes?				
16	PATHWAYS				
17	Pathways wide enough? 60" x 60" space on landings				
18	Pathway edges clearly defined by colors & tactile surfaces?				
19	Pathway ramps built to 1:12 slope or approx 10% incline?				
20	Path width adequate of 36"?				
21	Handrails installed where needed and at proper height and construction?				
	BOATHOUSE ACCESS				
22	Boathouse door width ADA compliant?				
23	Entrance door to boathouse high contrast color?				
24	If glass door, visible when closed?				
25	Door handles have large pulls and ADA height?				
26	Glass door markings visible at wheelchair height?				
27	Floor surfaces and connections negotiable by wheelchair users?				
28	Boat bays wide enough to avoid equipment?				
29	Bays clearly marked by color & tactile surfaces?				
30	Floor space clear of obstacles?				
31	Boats, oars, pontoons easy access?				
32	Equipment stored at height & location easy to access by wheelchair users?				
33	Club has adequate equipment to match the needs of the rower?				

Page 2 Checklist of Facility Accessibility

	ELEVATORS	N/A	YES	NO	ACTION
34	Available to all floors?				
35	Doors open to appropriate width?				
36	Can doors be distinguished from surrounding walls?				
37	WATER ACCESS				
38	Is water approach accessible?				
39	Is boating area accessible?				
40	Accessible ADA compliant ramps for wheelchair users?				
41	Ramp access takes into account any tidal/water level changes?				
42	Is dock stable?				
43	Adequate space for assisted moving, transfers and athlete support?				
44	Hoist available for moving and transfers?				
	BATHROOM FACILITIES				
45	Accessible toilet in close proximity to docks?				
46	Accessible toilet facility indoors?				
47	Space enough for right and left transfers and to turn around 60-degrees				
48	Appropriate sink height for wheelchair users?				
49	Hand dryer/towel dispenser at appropriate height?				
50	ADA compliant handrails and fixtures installed at correct height & high vis color?				
51	All routes to bathrooms unobstructed for wheelchair users?				
52	Shower handles easy to operate by limited hand function.				
	SIGNAGE				
53	Signage current, consistent, relevant throughout facility?				
54	Boathouse entry/exit to boathouse and parking clearly identified?				
55	Signage at consistent height throughout?				
56	Signage simple with approved pictorial language and sensory formats?				
57	Signage not blocked and visible from seated and standing positions?				
58	Signage tactile for visual impaired?				
59	Emergency alarm system audible and also supplemented by visual/tactile system?				
60	Emergency exit routes level and accessible to all on ground floor?				
61	Written information available in appropriate language and sensory formats?				
	COMFORT/SAFETY				
62	Tent for shade on hot days (rowers w/o temp control) to rest				
63	Location to secure wheelchair, orthotics, prosthetics				
64	Service dogs- water, shade, tie-up?				

(Checklist adapted from the Adaptive Rowing: A Guide, Simon Goodey, www.britishrowing.org.)

Initial Athlete Process

In order to meet everyone's expectations, a process needs to be established to make sure a solid, two-way communication is established between the rower and the program. The following is a suggested first meeting, or "intake" process:

- ✓ Athlete classification is assessed (LTA, TA, PD, or other method of assigning an adaptive rowing program), and the outreach director or program coordinator records the relevant information.

NOTE: HIPAA Privacy Rule provides federal protections for individually identifiable health information held by covered entities and their business associates and gives patients an array of rights with respect to that information. At the same time, the rule is balanced so that it permits the disclosure of health information needed for patient care and other important purposes.

*****Any health records or applications being collected must be secured by the managing organization as a matter of privacy. Information may be shared with a coach or volunteer working directly with the adaptive rower as it pertains to the disability or the management of symptoms that are pertinent ONLY to rowing. ******

- ✓ Staff recommends appropriate program and participant registers online.
- ✓ First session meeting is scheduled with coach.
- ✓ Participant contacts coach regarding attendance (ongoing).
- ✓ Coach tracks attendance and progress (ongoing).
- ✓ Recommendations made for subsequent sessions at the end of the term.

Keep in mind that the individual you are coaching has probably been living with his or her disability for some time and will be willing to share whatever information you need to help support them through the process.

Try to keep the interview process as comfortable as possible for the athlete and find a comfortable, quiet place, with no distractions to meet with the athlete. Invite a family member or support volunteer to join the athlete for his or her first meeting. This is a great way to get the family involved and ease the athlete through a potentially stressful time.

The next step is to communicate any supporting information to the coach or volunteer working with the athlete.

Additional questions to ask the rower:

- What are your expectations? Current experience?
- What type of rowing are you interested in – exercise, Para, rec competition?
- Does your ability match that type of rowing?
- How long have you had the disability?
- Do you have any associated conditions that we need to be aware of that might be exacerbated due to rowing?

- What are your concerns?
- (Partial VI) What can you see?
- Do you have any specific needs?
- How do you usually do this particular activity? (transfers, guided walk, etc.)



A sample of a two-page adaptive rowing application courtesy of Philadelphia Rowing (PAR) follows:

2013 Rowing Applicant Evaluation

Philadelphia Adaptive Rowing



Note: This form for rowers. Volunteers, DO NOT fill out this form unless you have a disability.

1

Your Name: _____

All information provided is strictly confidential and used solely for the purpose of evaluating an applicants suitability for rowing.

Please check and complete the column(s) that best describe your disability

2

<input type="checkbox"/> SCI Level of Injury: _____ <input type="checkbox"/> Complete <input type="checkbox"/> Incomplete <input type="checkbox"/> Spina Bifida	<input type="checkbox"/> Amputation Location/Levl _____ _____ _____	<input type="checkbox"/> CVA <input type="checkbox"/> Hemi: L R Other _____ _____ _____	<input type="checkbox"/> Multiple Sclerosis Describe _____ _____ <input type="checkbox"/> Muscular Dystrophy Describe _____ _____
<input type="checkbox"/> Cerebral Palsy Type _____ <input type="checkbox"/> Hemi: L R <input type="checkbox"/> Lower <input type="checkbox"/> Upper <input type="checkbox"/> Single	<input type="checkbox"/> Visual <input type="checkbox"/> Blind <input type="checkbox"/> Visual Impairment Describe _____ _____ _____	<input type="checkbox"/> Brain Injury Describe _____ _____ _____	<input type="checkbox"/> Any Other Medical Conditions Describe _____ _____ _____

3

Medications: _____

Allergies: _____

Seizures: Yes No Type: Grand Mal Petit Mal Date last seizure: _____

Seizure controlling meds: _____

Continued on Reverse Side ----->

Please answer the following

4

- 1 Are you able to swim without any flotation aids? Yes / No
- 2 If no to above, are you "water safe" (able to tread water)?* Yes / No
3. Do you have problems with thermo-regulation (temperature regulation)? Yes / No
4. Do you need to restrict your activity in high temperatures? Yes / No
- 5 Do you have an aid/helper whom you would need while at the boathouse? (see note 1. below)** Yes / No
- 6 Why are you interested in rowing? (Check all that apply)
 - Competition
 - Recreation
 - Exercise
 - Social
- 7 Do you participate in other sports, recreational or competitive?
- 8 How did you find out about PAR? (Check all that apply)
 - Friend
 - Web
 - Rehab
 - Other
- 7 Do you have a family member or friend who may be interested in helping with PAR?

NOTE 1.: PAR provides assistance in transferring to and from boats, and during rowing. PRPD does not provide those activities that a required aid or attendant would provide.

*PFD required of answer is "No"

Please add any additional comments

5

Safety Protocol for the Athlete

The adaptive athlete should be treated in all regards like all members of the rowing organization and should be required to meet the established safety protocols specific to the organization, location and facility. If the organization does not have established protocols, it can start by utilizing the numerous videos and other tools available through USRowing to ensure a safety plan is in place for all rowers (<http://www.usrowing.org/safety.aspx>).

- [USRowing Safety Video](#)
- [USRowing Safety Poster](#)
- [Pre-Practice Safety Checklist](#)
- [Safety Information Links](#)
- [Safety Committee](#)
- [Safety Features](#)
- [USRowing Safety Guidelines](#)
- [Trailing Laws and Safety](#)
- [FISA Safety Guidelines](#)
- [Personal Flotation Device Safety Purchasing Program](#)
- [Boathouse Doc](#)
- [Kippy Liddle Safety Kit](#)
- [Pre-Packaged Gear Kits - Coach, Referee, Coxswain, AED and PFD Belt Pack](#)
- [PASS \(Peril Assessment Scoring System\)](#)

Safety On the Water – Supervising an Adaptive Rowing Program

The question of what is considered enough supervision is challenging, and there is no exact formula for determining a supervision plan. The answer is dependent on the circumstances and the people involved. Coaching novices is very different from coaching an experienced crew. Is the coxswain new or experienced? What are the conditions? Rowing on a small pond is very different from rowing on a river with current or in open water conditions with tides and waves. Even in perfect conditions, accidents can happen. Each coach has to assess how many people he or she can get to safely and quickly.

And what about the coach or person supervising the program? What qualifies a person to supervise an adaptive rowing program? Certainly there needs to be a training procedure in place, which might include the same training and qualifications a person needs to satisfy to get their “Captains” certification, or similar qualification. The coach should invest enough time with the adaptive athlete to be familiar with the rower’s specific disability and learn best practices for the athlete and their equipment. A coach should not take out more boats than she can supervise at close range, and the boats need to remain in the same relative area in the event there is an accident. Ask, if something were to happen, can the rower be reached quickly and is the coach prepared to perform a possible underwater rescue with swim goggles in cases of equipment failure or where the rower has suffered a medical issue like a seizure?

Each program should have a safety protocol written as part of its training procedures. Communication devices, like radios and cell phones, and current emergency contact information should be included as part of the daily safety checklist.

Lastly, review the procedures with the athletes and let them know what to do in the case of an emergency before they step foot into a boat. Get into a safety routine from the start. Involve the athlete and take the time to go through the necessary steps to be sure everyone is as safe as possible.

Other safety considerations to discuss on a regular basis with adaptive rowers:

- Traffic pattern of local waterway
- Club-specific rules
- Hydration and nutrition

Charles River Traffic Patterns

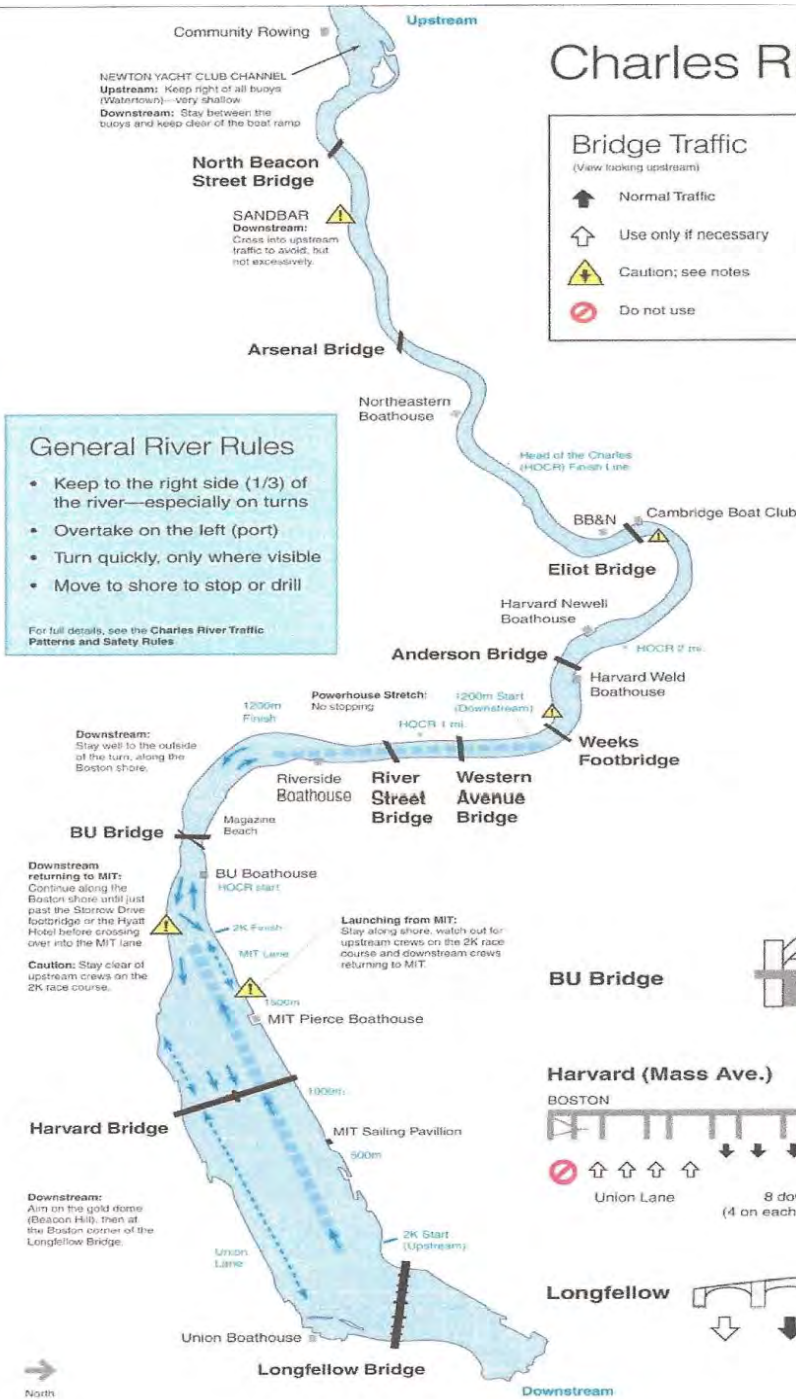

General River Rules

- Keep to the right side (1/3) of the river—especially on turns
- Overtake on the left (port)
- Turn quickly, only where visible
- Move to shore to stop or drill

For full details, see the **Charles River Traffic Patterns and Safety Rules**

Bridge Traffic
(View looking upstream)

- ↑ Normal Traffic
- ↑ Use only if necessary
- ⚠ Caution; see notes
- ⊘ Do not use

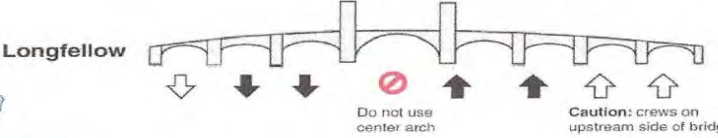
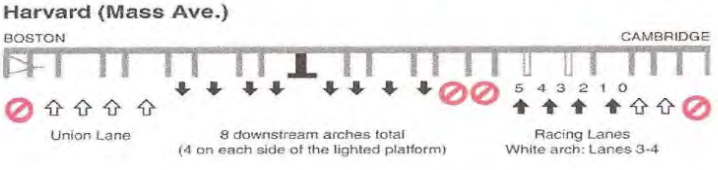
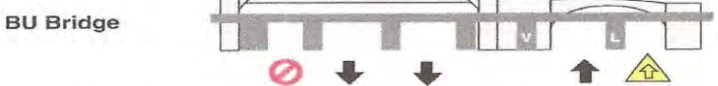
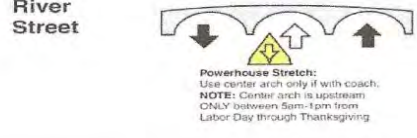

(Map from Community Rowing Inc., Boston, Mass.)

Adaptive Rower Documentation

Documentation for the adaptive rower will be the same as non-disabled rowing members of your organization – with a few additions, as the obvious outcome of any documentation is clear communication of expectations – both on the part of the rower and rowing program.

Each program may vary its application process. The swim test, though highly recommended, is not required for the adaptive rower to be covered by USRowing liability insurance. Below are samples of a graduated swim test and rigging info used by established USRowing adaptive rowing programs.

Checklist – Adaptive Rower Documentation

- Membership application – standard club app
- Intake/medical form (sample from PAR)
- Swim test (sample from Rio Salado)
- Emergency contact card – with on-water coach
- Rigging card (sample from PAR)
- Register athlete – electronic communications system (listserve, etc)

It's all about communication – collect information and share it appropriately.

Once the preliminary application process is complete, all emergency information for the adaptive rower should be collected for the coach to have on hand in case of emergency including:

- Rower's name
- Rowing classification/special considerations/treatment (as it pertains to rowing)
- Rower's contact info – phone/email
- Family/aid/friend name
- Family/aid/friend contact info – phone/email
- Doctor's phone
- Other pertinent medical information

Sample Equipment Rigging Cards

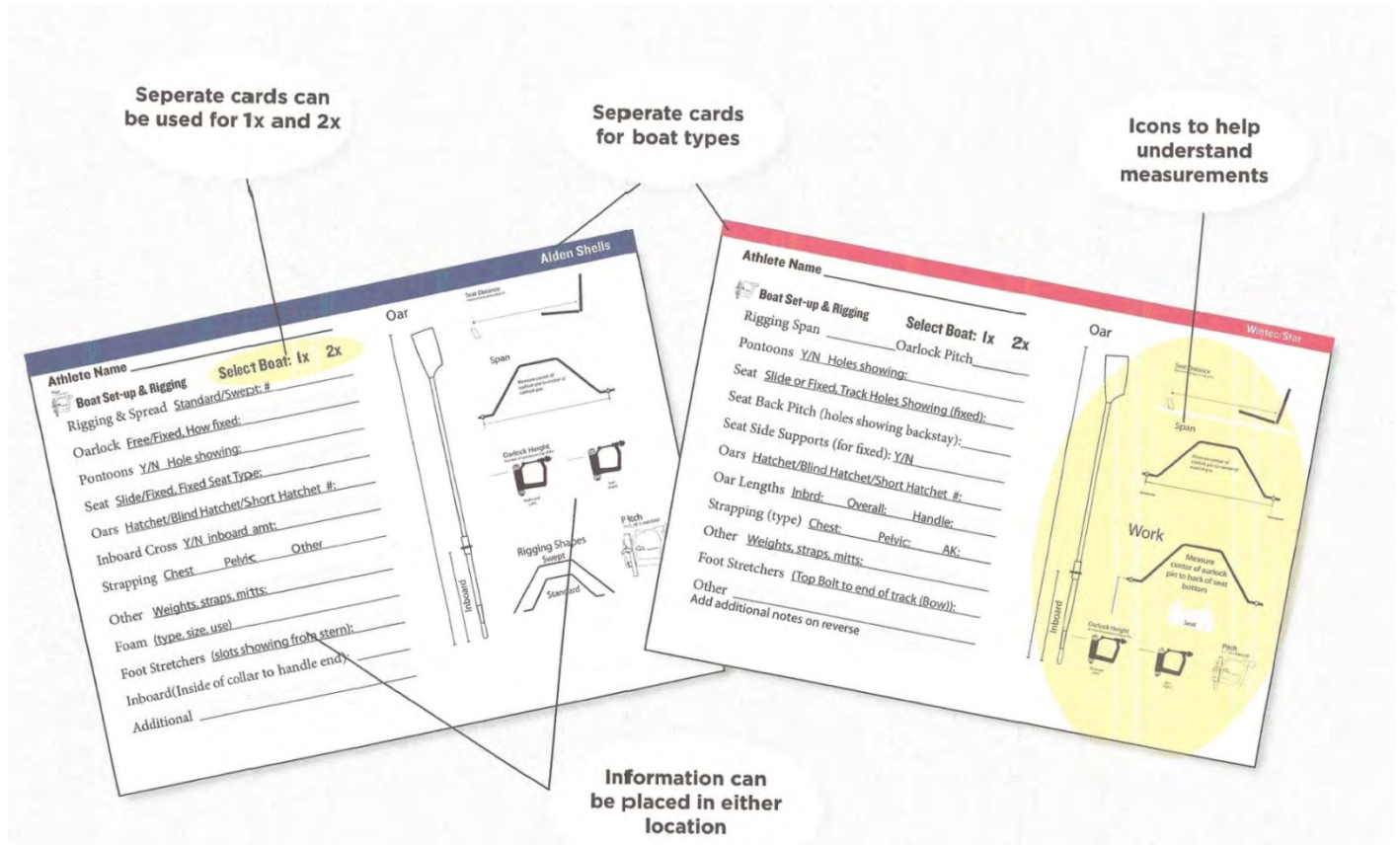

(Courtesy of Pennsylvania Center for Adaptive Sports Rowing – PAR)

To help save time and to engage the athletes, it might be helpful to record the specific rigging information for each athlete in order to be ready for his or her rowing session.

Guidelines for when and how the equipment is used should be posted and reviewed with the athletes.

Sample of Progressive Swim Test

NAME:		DATE:		COACH:	
RSRC Adaptive Rowing Float Test					
Demonstrate ability to stay afloat in the water. Demonstrate level of ability to don/use personal floatation device.					
Float Test					
YES	NO	Wearing a long-sleeved shirt, remain afloat for ten minutes.			
<i>If YES, proceed to Tossed PFD Test.</i>					
<i>If NO, proceed to Manual Inflation PFD Test.</i>					
Personal Floatation Device Test					
Yes	No	Tossed PFD Test: While in water, rower can don, secure, and comfortably float in a standard PFD tossed to him or her.			
If YES, cleared to row without wearing a PFD.					
If NO, proceed to manual inflation PFD test.					
Yes	No	Manual Inflation PFD Test: While wearing an inflatable PFD in the water, rower can manually inflate and comfortably float in it.			
If YES, rower is cleared to wear a manually inflatable PFD while rowing.					
If NO, rower is cleared to wear an automatically inflatable PFD while rowing.					
Determination:					
_____ Rower is able to row without wearing a PFD.					
_____ Rower is able to row with a manually inflatable PFD.					
_____ Rower is able to row with an automatically inflatable PFD.					
_____ Rower is uncomfortable in the water and will require high level monitoring.					
_____ Coach Signature				_____ Date	
_____ Lifeguard Signature				_____ Pool	
(Coach and lifeguard will determine level of PFD rower must use while rowing.)					

(From Rio Salado (Ariz.) Adaptive Rowing Program)

Athlete Progression

The progression of the athlete after the initial meeting is the same as any novice rower, with the addition of an evaluation with recommendations and methods to maximize the rowing stroke given the particular impairment of the individual. Typically, the coach progresses through the following phases, depending on the needs of the rower and the type of program, which may include all or some of steps listed below.

- 1) Movement/ability analysis – done during the initial meeting and review of the impairment
- 2) Erg – introduction to the machine and stroke demonstration, including a tactile demonstration, if needed, in the case of the VI athlete.
- 3) Rowing tank or Dock Box
- 4) Rowing stationary on dock – using a rowing rig or shell set up out of the water
- 5) Rowing in the boat with a volunteer or coach – coach to rower ratio 1:1
- 6) Rowing in the boat “on a rope” or tethered to the dock
- 7) Boat with other athlete(s) in a boat – coaching launch supervised



Athlete Involvement – Coaching Tips

FOCUS ON SAFETY – COMFORT – ENCOURAGEMENT – FUN

Rowing is the ideal activity for adaptive athletes, as it provides social networking opportunities, camaraderie, and competition, as well as improves physical and mental health, improves independence, supports academic achievement, and employment advancement.

It is important to keep the athlete involved with his or her athletic process. Be sure some consideration has been involved with matching the athlete with a volunteer/coach who makes him or her comfortable. Check in with the athlete during their session and encourage the athlete to assist with moving equipment whenever possible.

Adaptive athletes should be encouraged to participate as full members (with all rights and privileges) of the organization and board.

Talk about the athlete's goals and continue to challenge him or her. Provide technical instruction and be prepared to update goals as the athlete shows improvement. Lastly, hold the athlete accountable to improving and find ways to keep him or her motivated to move to the next level.

Adapt your style of coaching to meet the needs of the rower. Allow for more time and provide more direction. **LISTEN MORE AND TALK LESS.** Remember, the athlete has been living with his or her disability and is the best resource for working with the disability.

Be open, smile, ask how to help, and show you care.

Coach to MOTIVATE

Adaptive Rowing – Special Coaching Considerations

Specific disabilities present specific challenges to the adaptive rower. *This section will be expanded as more adaptive rowers enter the sport and further information is shared on how to adapt the equipment and methods to be better rowing coaches.*

Physical Needs

Some adaptive athletes may be unable to self-monitor for hydration, overheating or pain, so be familiar with their condition and remind them to drink water, allow for breaks and check in with them for rowing-related injuries. Rowers susceptible to skin breakdown need to keep the skin dry, clean and avoid abrasions and over compression. Over exertion or lack of proper support may cause spasticity.

Physical Disability Definitions

Hemiplegia – Same side of arm, trunk, and leg

Diplegia – Both legs, lower pelvis

Triplegia – Three limbs and partial trunk (i.e., two legs and one arm)

Quadriplegia – all limbs and trunk

Hypertonia – spasticity, or resistance, in muscle to change its length

Dystonia – abnormal posture/movements resistant to bending and flexing

Amputation – Use of prosthesis

- Ask each rower how she wants her prosthesis moved, stored or secured while rowing, if the rower doesn't use it to row.
- Muscular imbalances need monitoring, so the body doesn't over compensate.
- Consider use of weighted sandbags to balance the boat.
- Monitor pain and "phantom" pain, which may signal an issue for the rower to bear weight or row.
- Always use the correct padding to prevent sores due to shear forces and friction.
- Less skin surface area = increased perspiration. Monitor overheating and hydration.
- Monitor stump and skin surfaces. Sanitation and thorough drying of contact points are important.

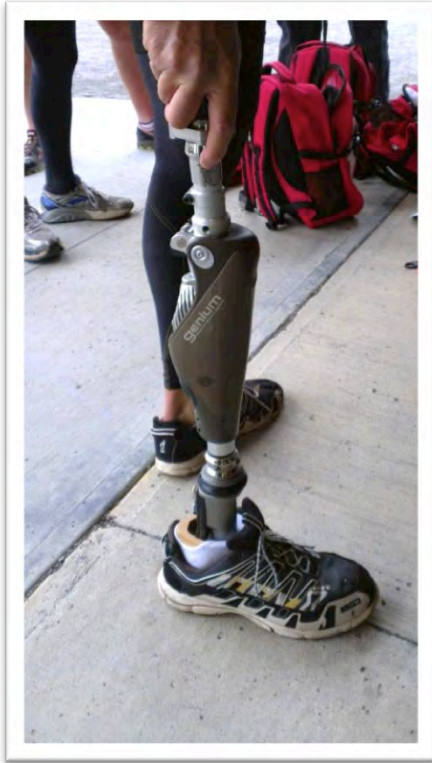

Balancing the boat

Adaptations do not have to be complicated or expensive. A rower with a major amputation may find it helpful to use weights or a sandbag to augment the missing limb to balance the boat. The system used should be easy to transfer among boats. A creative idea is to use one or two string backpacks that are given out at events as a promo gift item. They are small enough to adjust, and the straps allow the athlete to carry the pack. Initially, the rower should sit in a single (1x) to adjust the amount of sand needed to correct the balance.

Line the pack with two layers of large plastic bags and fill with sand. Place the bag in the foot well of the boat and have the rower face the dock stern in. While lifting the oars off the water, eye the rigger height to be sure the boat remains level for the amount of sand used. It may take a few adjustments. Keep a trowel and pail of sand handy on the dock while making the adjustments. The entire process should be easy, and the results will help improve the rower's comfort, balance and speed.

Appliances – leg bag, colostomy or catheter

Check with the rower before a transfer to be sure the appliance is not moved out of place, how to handle the appliance, and where to locate it in the boat.

Cerebral Palsy (CP)

While cerebral palsy is commonly described by loss or impairment of motor function, cerebral palsy is actually caused by brain damage.

The brain damage is caused by brain injury or abnormal development of the brain that occurs while a child's brain is still developing – before, during or immediately after birth.

Cerebral palsy affects body movement, muscle control, muscle coordination, muscle tone, reflex, posture and balance. It also can impact fine motor skills, gross motor skills and oral motor functioning.

Rowing increases strength, but it is important to work on non-weight bearing workouts at first to gain flexibility. Work to find the best strokes per minute (SPM). Rowers with CP use more energy due to complications of CP hypertonicity, which is important to monitor during training. Limbs may be rigid and require additional support with padding and straps to help prevent hypertonia and to support the rower in the proper position due to dystonia.

Cognitive and Brain Impairment

Includes disabilities with some behavioral implications such as TBI, ADAD, stroke, dyslexia and cognitive development impairments.

Helpful points for rowers with cognitive impairments:

- Smaller student-to-coach ratio, row tandem
- Teach at a slower pace, followed by review
- Repeat information as needed, using short, one-word commands
- Break down the instructional segments into smaller bits of information
- Build in rest periods
- Teach using practical demonstrations that can be observed
- Make laminated cards with pictures to use to teach certain parts of the equipment or stroke
- Ask questions to be sure the point is understood before moving on
- Put strips of colored tape on the gunwale where the rower needs to begin and end the stroke
- SING! Music is relaxing and *Row, Row, Row Your Boat* works well for establishing rhythm
- Acknowledge correct physical performance and verbal responses frequently
- You may have to remind the athlete to hydrate and check on other physical needs
- Make direct eye contact and speak the person's name to redirect their behavior

Traumatic Brain Injury (TBI) – Common with war injuries and auto accidents.

The Individuals with Disabilities Education Act (IDEA) defines traumatic brain injury as: “an acquired injury to the brain caused by an external physical force, resulting in total or partial functional disability or psychosocial impairment, or both, that adversely affects a child’s educational performance. Injuries result in impairments in one or more areas, such as cognition; language; memory; attention; reasoning; abstract thinking; judgment; problem-solving; sensory, perceptual, and motor abilities; psycho-social behavior; physical functions; information processing; and speech.

Rowers with a TBI may be relearning how to do daily activities, regaining coordination mobility, and are managing cognitive, emotional and behavior symptoms.

Physical symptoms of TBI may include:

- Headaches
- Fatigue easily
- Difficulty with speech or hearing
- Dizziness or trouble with balance or motor skills
- Blurry eyesight
- Nausea

Cognitive symptoms of TBI may include:

- Repeating things
- Forgetfulness
- Difficulty concentrating
- Difficulty making decisions
- Memory challenges

Behavioral Symptoms of TBI may include:

- Easily frustrated or angered
- Impulsive behavior

Post Traumatic Stress Disorder (PTSD)

An ongoing mental health condition related to exposure to an event that results in psychological trauma, PTSD may be caused by witnessing death or harm to someone's physical, sexual or psychological integrity. Diagnostic symptoms for PTSD include re-experiencing the original trauma, avoidance of stimuli associated with the trauma and increased arousal.

Symptoms vary and can include a variety of these listed below.

Physical symptoms PTSD:

- Pounding heart rate
- Rapid breathing
- Nausea
- Muscle Tension
- Sweating

Cognitive symptoms PTSD:

- Re-experiencing the original trauma
- Avoidance of stimuli associated with the trauma (especially loud, sudden noises)
- Increased arousal

Behavioral symptoms of PTSD:

- Difficulty falling or staying asleep
- Irritability or outburst of anger
- Difficulty concentrating
- Hyper vigilance (on constant "red alert")
- Feeling jumpy and easily startled

Having PTSD also may place the person at a higher risk of other mental health problems including depression, drug abuse, alcohol abuse, eating disorders, suicidal thoughts and actions.

Avoidance Symptoms: A person with PTSD may go out of his or her way to avoid certain people, places or activities. He may experience emotional numbing and have difficulty remembering the important parts of the traumatic event. She may have a loss of interest in what were previously positive activities for them. He may have difficulty experiencing or displaying feelings of positive behavior such as happiness or love.

Triggers, such as sudden or loud noises, physical contact, particular places or even specific people can cause an episode. Be prepared for behavior changes including mood swings, anger and frustration. Don't hover over the athlete when symptoms present. Remind the person who the people are surrounding them that they are safe and ask them if they need some time to recover.

Triggers cannot always be anticipated, but learning each individual's triggers and encouraging the athlete to follow his or her individual pace and comfort level can help prevent them.

Avoidance is a normal response to trauma and upsetting events. Rowing can act as a trigger due to the responses it elicits regarding trust issues and being on the water or being with other people. Encourage the rowers to interact as this often can improve the outcome of a rowing session. Prepare the athletes ahead of time with what could happen out on the water and what they should do in case of a capsize, passing a large or loud group of rowers, etc. Plan programming for quieter, less busy times of the day. For better results, it is good to have the athletes develop mutual goals and work together as a group, as opposed to the traditional coach directed style.

Communication is key when coaching athletes with a TBI and/or PTSD.

Some approaches to a more successful teaching session include:

- Have the athlete row in a quiet or private location
- Focus on short-term goals
- Allow for more time to make decisions
- Practice active listening
- Take time to understand the individual, make sure the athlete understands and avoid interrupting the person
- Be prepared to repeat both orally or in writing
- Keep directions simple
- Wait for the rower to accept the offer of assistance; do not "over-assist" or be patronizing.

Signs that the rower with PTSD may need assistance:

Body language

- Fidget
- Lack of eye contact
- Isolate themselves

Facial Expressions

- Scared
- Like they might cry
- Overwhelmed
- Confused
- Lost

What can you do to help?

- Be understanding and patient
- Ask if someone needs help
- Make them comfortable
- Use enthusiasm
- Use humor
- Be positive
- Talk calmly
- Don't touch them if they appear that space is needed
- Check for a medical ID bracelet or necklace, if needed
- Ask them, "What can we do to help you right now?"
- Help them find the "Comfort Zone"

(Additional material regarding TBI and PTSD used with permission from Bridge2Sports Organization, <http://www.bridge2sports.org>, and the U.S. Department of Veteran's Affairs.)



ASD & Autism (1 in 110 children has an ASD)

Autism spectrum disorder (ASD) and autism are both general terms for a group of complex disorders of brain development. These disorders are characterized, in varying degrees, by difficulties in social interaction, verbal and nonverbal communication, and repetitive behaviors. ASD can be associated with intellectual disability, difficulties in motor coordination and attention and physical health issues such as sleep and gastrointestinal disturbances.

1. Outline tasks in sequential order.
2. Always keep language simple and concrete. Get the point across in as few words as possible.
3. Teach specific social rules/skills, such as turn-taking and social distance.
4. Give fewer choices. If a child is asked to pick a color, say red, only give him two to three choices to pick from. The more choices, the more confused an autistic child will become.
5. If when asking a question or giving an instruction there is a blank stare, reword the sentence. Asking a student what was just said helps clarify that it has been understood.
6. Avoid using sarcasm. If a student accidentally drops an oar on the floor and the response is "Great," it will be taken literally and this action might be repeated on a regular basis.
7. Avoid using idioms. "Put your thinking caps on", "Open your ears" and "Zipper your lips." These will leave a student completely mystified and wondering how to do that.
8. Give very clear choices and try not to leave choices open ended. "Do you want to go in now?" will get a better result than asking, "What do you want to do now?"
9. Repeat instructions and check understanding. Use short sentences to ensure clarity of instructions.
10. Provide a very clear structure and a set daily routine including time for play.
11. Use laminated pictures of the rowing technique and equipment, so the student can get a clear image of what is expected.
12. Provide warning of any impending change of routine or switch of activity.
13. Address the rower individually at all times. For example, the rower may not realize that an instruction given to the whole crew also includes him or her. Calling the rower's name and saying, "I need you to listen to this, as this is something for you to do" can sometimes work.
14. Use various means of presentation – visual, physical guidance, peer modeling, etc.
15. Recognize that some change in manner or behavior may reflect anxiety, which may be triggered by a [minor] change to routine.
16. Do not take apparently rude or aggressive behavior personally; recognize that the target for the pupil's anger may be unrelated to the source of that anger.
17. Avoid overstimulation. Minimize/remove distractions or provide access to an individual workout area. Rowing in noisy or busy surroundings can be distracting.
18. Seek to link rowing to the rower's particular interests.
19. Protect the rower from teasing at free times, and provide peers with some awareness of his or her particular needs.
20. Allow some access to obsessive behavior as a reward for positive efforts.

(Taken from teacher Pat Hensley, adjacent instructor Furman University, 2008)

Epilepsy

The decision for an athlete with epilepsy to row needs to involve the athlete's health team, family, coaches and program administrators.

Many factors need to be considered before permitting a rower with epilepsy to participate in a rowing program such as:

- Seizure type and frequency
- Medication side effects
- Other medical or developmental problems that affect the athlete's activities
- The athlete's ability to follow instruction and act responsibly
- The type of exercise
- Safety precautions that need to be taken
- Benefit of rowing and participating in rowing

A trial period may be recommended to see how the stresses of rowing might affect the athlete. Many athletes can participate without rowing triggering an epileptic seizure including competitive rowing programs. A rower might be recommended for an on-land erg program or non-competitive rowing program as alternatives.

Seizures and epilepsy are not the same. An epileptic seizure is a transient occurrence of signs and/or symptoms due to abnormal excessive neuronal activity in the brain. Epilepsy is a disease characterized by an enduring predisposition to generate epileptic seizures and by the neurobiological, cognitive, psychological and social consequences of this condition.

Translation: a seizure is an event and epilepsy is the disease involving recurrent unprovoked seizures.

About 326,000 American children under the age of 15 have epilepsy and 20,000 new cases of epilepsy are diagnosed each year.

Epilepsy affects people at different ages and in different ways. For some, it will be a temporary problem, easily controlled with medication and outgrown after a few years. For others, it may be a lifelong challenge affecting many areas of life.

Exercise rarely provokes seizures, but it is possible if the rower gets too tired or dehydrated while exercising. Be aware of hydration and the need to rest. If a pattern exists between seizures and exercise, plan accordingly and avoid typical seizure triggers.

What are some commonly reported triggers?

- Specific time of day or night
- Sleep deprivation – overtired, not sleeping well, not getting enough sleep
- At times of fevers or other illnesses
- Flashing bright lights or patterns
- Alcohol or drug use
- Stress

- Associated with menstrual cycle (women) or other hormonal changes
- Not eating well, low blood sugar
- Specific foods, excess caffeine or other products that may aggravate seizures
- Use of certain medications

All reasonable safety precautions should be taken, which include:

- The rower with epilepsy needs to be under close supervision and at close range to the supervisor or coach's launch.
- The coaches, crew, volunteers and other group members need to be informed that the rower has epilepsy and have a well-versed safety plan in place should the rower have a seizure.
- Although not recommended, some organizations (that may supercede the rowing organization, like a city or state program) may exempt a rower from taking a swim test.
- In case of capsizing, it is recommended the rower with epilepsy wear a water-activated life jacket.

<http://www.epilepsy.com>

Spinal Cord Injury

An adaptive rower with an AS or TA classification may typically have a spinal cord injury (SCI) resulting in one or a combination of:

- Loss of feeling to the lower extremities
- Loss of bladder and bowel control
- Restricted blood circulation
- Insulin metabolism issues
- Body temperature regulation issues
- Bone density issues
- Auto Dysreflexia (AD) or Hyperreflexia (considered an emergency – see below).
Is a condition where the involuntary nervous system overreacts to external or bodily stimuli. This reaction causes a dangerous spike in blood pressure, racing heart, constriction of peripheral blood vessels and other changes in the body's autonomic functions.

Triggers for autonomous dysreflexia (AD) in persons with spinal cord injuries can be anything that generates nerve signals including:

- Distended bladder
- Blocked catheter
- Urinary retention
- Urinary tract infection
- Bladder stones
- Constipation
- Bowel impaction
- Hemorrhoids
- Skin irritations
- Pressure sores

- Tight clothing

Symptoms of AD might include:

- Anxiety and apprehension
- Irregular or racing heartbeat
- Nasal congestion
- High blood pressure, with systolic readings often over 200mm Hg
- Pounding headache
- Flushing of the skin
- Profuse sweating, particularly on the forehead
- Lightheadedness, dizziness or confusion
- Dilated pupils

Treatment: Emergency medical treatment is required and is aimed at lowering the blood pressure and eliminating the stimuli that are triggering the reaction.

Emergency measures may include:

- Placing the patient in a sitting position to cause the blood to flow to the feet
- Removing tight clothes and socks
- Checking for a blocked catheter
- Draining the bladder with a catheter, if it is distended
- Removing any other potential triggers such as drafts of air blowing on the patient or objects touching the skin
- Treating the patient for fecal impaction
- Administering vasodilators or other drugs to bring the blood pressure under control

Rowers with a SCI should take care to wear protective clothing (protect from sun or additional clothing to stay dry and warm), hydrate adequately and avoid training in extreme humidity, heat or cold.

(A.D.A.M., Inc. (2010). Autonomic hyperreflexia. <http://www.nlm.nih.gov/medlineplus/ency/article/001431.htm>)

(Apparelyzed.com. (2012). Autonomic Dysreflexia & Hyperreflexia. <http://www.apparelyzed.com/autonomic.html>)

(Medscape (2012). Autonomic Dysreflexia in Spinal Cord Injury. <http://emedicine.medscape.com/article/322809-overview#aw2aab6b3>)

Hearing Impairment (HI) – Full or Partial Loss of Hearing

- Requires some advance training for the coach to work out signals and demonstrations with the athlete prior to practice. Hand signals are the most simple to use. Have a system that covers basic rowing commands, directions and safety.
- Use a bright color signal, like a neon flag, to communicate with the athlete.
- Speak clearly and simply, so the athlete can read lips. Be aware a mustache may impede this function!
- Stand facing the sun so face is visible when speaking.
- Utilize drawings as often as needed to explain technique directions, a route or lesson plan.
- Have rower demonstrate they understand instructions by having them perform the movement, preferably next to the rower on an erg or in a boat.
- A light tap (vibration) on the hull near the rower will create a vibration that can work to get a rower's attention.
- Hearing Aids are expensive. Be sure they are stored in a waterproof bag.



Wheelchairs and Other Mobility Devices

Ask the rower how he wants his chair moved, stored or secured while rowing. Respect the rower and do not lean, sit on or allow anyone to play with someone's chair or disturb the belongings stored with the chair.

Visual Impairment (VI) – Partial or Full Visual Impairment

To truly tap one's ability as a coach to work with visually impaired rowers, coaches should plan a time to wear light obscuring goggles and do a complete rowing experience. Coaches will have to access their other senses of hearing and touch to compensate for the loss of sight. Coaches will need to be able to verbalize rowing technique without using their hands. Coaches should role play with a non-rower until they are able to communicate directions clearly and precisely.

- Establish level of vision with the rower by asking:
 - Rower with some vision – “What can you see?”**
 - Rower without vision – “How do you usually learn to do new things?”**
- When leaving a rower, be sure they are in contact with an object, like a bench or railing, so they can orientate themselves.
- Coaching needs to be verbal but also tactile – between the coach to rower and rower to equipment.
- Always ask if the rower is comfortable being touched or guided.
- Land-based erg training should always proceed on-water rowing.
- A physical orientation of the grounds and facility should proceed any rowing.
- Workout instructions prior to going out on the water. Provide a list of general commands and vocabulary beforehand in the preferred format – a scaled down version of the Coxswain's Glossary of Terms.
- Be explicit, providing more detailed instructions than normal.
- Allow for equipment “hands on” time, so rowers can understand where everything is located.
- Address the rower by name if in a group situation.
- Try to describe/compare the rowing stroke with other experiences with which they may already be familiar.
- Use the clock layout to describe where things are located (i.e. 6 o'clock for directly behind.)
- Create tactile models whenever possible. (Stand behind the rower and let them feel what it is like to pull the oar through the water while moving backwards.)
- Utilize tactile aids to provide indicators of location and orientation (oar handle, slide). A zip-tie, hair elastic with plastic balls, bike handle tape or bike inner tube sections attached to the grip or oar shaft are excellent, inexpensive tactile aids.
- As always, be sure the rower understands what they are being asked to do.
- Greet the rower so they know who is in the vicinity, the boat or working out in the erg area. “Hi Ann Marie! It's Sarah.” This allows them to get to know your voice and is a general courtesy.
- Keep the equipment area organized and located, so all adaptive rowers can access it.
- The initial orientation should include enough time for the VI rower to physically feel the boat, rigger, seat, tracks, stretcher and full length of the boat they will be rowing.
- Dock Launch – It is helpful to have the oar installed in the oarlock prior to guiding the rower to their seat position. Explain the “knob” on the oarlock always points towards the stern and they are to enter the boat on the opposite side of the knob and oar.

- Service dogs should not be touched or moved without permission from the owner. It is advisable to have a dog crate at the boathouse where they can be shut in to protect from “friendly petting” and secure the dog from theft. Be sure the dog has shade and access to water during the rower’s session.
- Practice water rescues in shallow water/controlled situations to prepare for a potential capsized. It can be reassuring to know how close you actually are to the water.
- Accessible Transportation – Besides proper signage for pick up and drop off, be aware not all services will escort the rower to the entrance of the rowing facility, and transit times are not always dependable regarding scheduling.
- Communications – Whether it is a team sign up, social occasion, or information bulletin, all communications from the organization need to be made available electronically to the VI rowing member, preferably in Microsoft Word or JAWS (*Job Access With Speech*), a computer screen reader program for Microsoft Windows that allows blind and visually impaired users to read the screen either with a text-to-speech output or by a Refreshable Braille display. JPEGs and PDFs can be converted, but this is a more cumbersome method.
- Equipment handling – Obviously, rowing equipment is expensive and practice times do not always allow for VI athletes to assist with boat handling, but try, whenever possible, to include the athlete with the process of handling the equipment. Carrying oars, pontoons or lightly assisting with a boat transfer are preferable.
- Launching Check List for VI Rower: It should be expected after some practice that the rower will take responsibility for their position as it relates to the boat. They should learn, despite the differences amongst boats, how to check that their seat is on correctly, the stretcher is perpendicular to the boat and secured at the proper distance for them, that the oarlock gate is secured, and the pontoon (if used) bracket pin is properly inserted and secured.

Communication Aids – See Equipment

- Two-way radios with head sets to support communication with the coach
- Voice assisted rowing applications for devices – ***BoatCoach, Erg Chatter, Erg Buddy***

EQUIPMENT

Adaptive rowing is all about equipment and what changes can be made to make it comfortable and usable for the adaptive rower. Many of the items may already exist in some form at the club and can be re-rigged or altered to be used by the adaptive rower.

Planning for the more expensive items, like adaptive-specific rowing shells, needs to be well thought out. Will the boat be used exclusively by one group or shared? Will it be rigged for both sliding and fixed seat? In both positions? What adaptations need to be included with the order to make this possible?

Sample Equipment Starter Package:

- Recreational 2x (1 adaptive rower, 1 coach)
- Recreational 1x
- Adaptive Racing 2x
- Adaptive Racing 1x
- Adaptive Pontoons
- AS Oars
- Fixed Seats
- Support Equipment (lifts, ramps, transfer equipment)

Rowers with physical impairments are more prone to sores and infection from the strapping and shearing action caused by rowing in a fixed seat. Put procedures in place to keep the equipment clean and dry. Schedule regular maintenance of the equipment, including the replacement of worn parts like Velcro straps, so that everything is in good working order. A well-organized and functional storage space is needed. Plan for storage that can be accessed by a person using a wheelchair. Consider keeping adaptive boats on rolling carts that can be handled easily by the rowers and support crew. The additional space needed and weight of the fixed seats mounted in a boat need to be taken into consideration. Whenever possible, locate the equipment near the entrance of the storage facility, so rowers with mobility challenges do not have to travel as far to assist with moving equipment.

Adaptive Equipment

Below is a partial list of items to consider when planning for your adaptive program:

- | | |
|---|---|
| <input type="checkbox"/> Boats | <input type="checkbox"/> Oars |
| <input type="checkbox"/> Communication Devices | <input type="checkbox"/> Padding |
| <input type="checkbox"/> Computer Programs | <input type="checkbox"/> Pontoons |
| <input type="checkbox"/> Erg Adaptors | <input type="checkbox"/> Pontoon Brackets |
| <input type="checkbox"/> FES Chairs – Spaulding Rehab | <input type="checkbox"/> Seat Pads |
| <input type="checkbox"/> Fixed Seats | <input type="checkbox"/> Slide Tracks |
| <input type="checkbox"/> Foot Adaptations | <input type="checkbox"/> Strapping |
| <input type="checkbox"/> Front Rower | <input type="checkbox"/> Transfer Options |
| <input type="checkbox"/> Grip Aids | <input type="checkbox"/> Tactile Aids |
| <input type="checkbox"/> Feather Lock Device | |

Boats – Adaptive Recreational Singles (1x)



Alden Quest



Piantedosi Row Wing



Echo with Folding Riggers

Alden 16 with Oarmaster Drop-in Unit



Alden 16 with Oarmaster and SUP Sliding Rigger Unit



Boats – Adaptive Racing Singles (1x)



Swift *1x

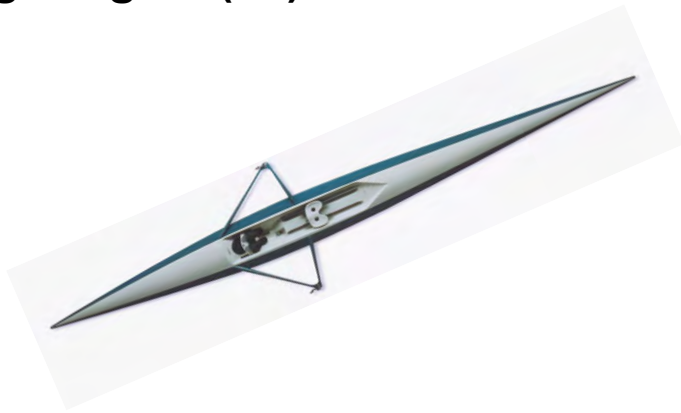

Maas Aero 1x



WinTech *1x



Fillippi *1x



Alden 1x

***Meets FISA Adaptive Equipment Standards**

Boats – Adaptive Recreational/Training Doubles (2x)



Alden 18 2x with Passenger/Coach



Piantedosi Row Wing in Canoe

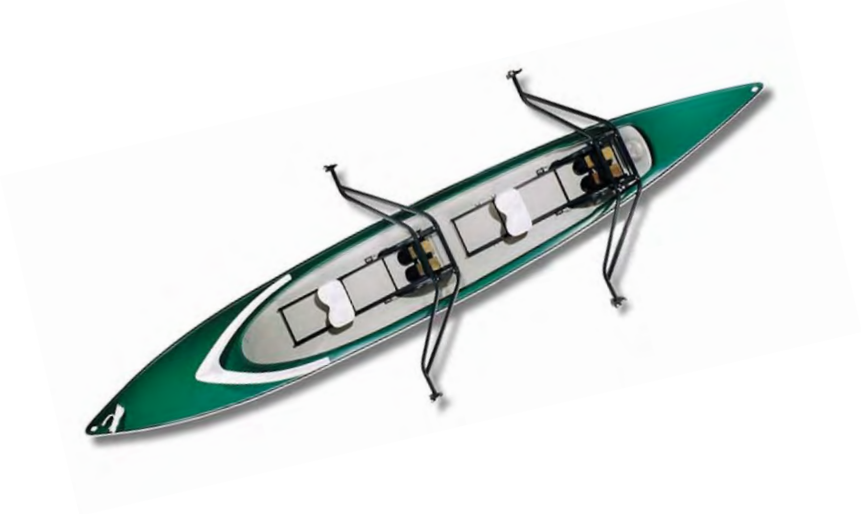

Alden 18 2x with Oarmasters

Boats – Adaptive Racing Doubles (2x)

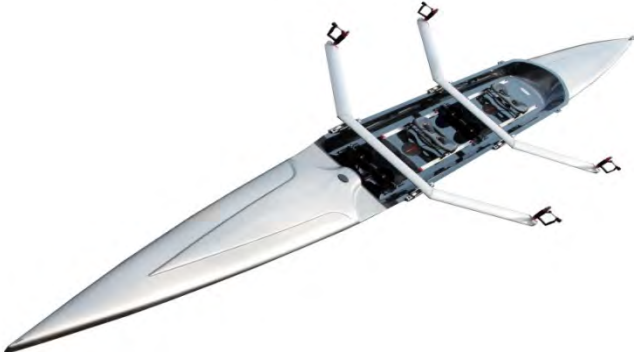

WinTech Explorer 30 2x*



Swift 30 2x *

Alden Star 30 2x



Filippi 2x*

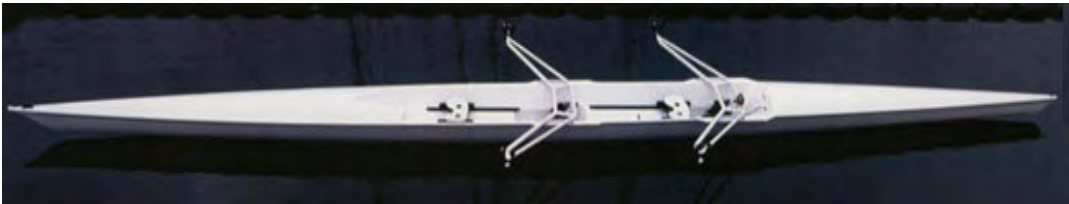

Maas 2x

(*) Meets FISA Equipment Standards

Equipment – Fixed Seats for Boats



Creating Abilities Fixed Seat



Swift Fixed Seat



WinTech Fixed Seat



Alden Fixed Seat



Swift Fixed Tractor Seat

Equipment – Erg Adaptations



WinTech Fixed Seat on an Erg



WinTech Erg Clamps



Concept2 Erg Tractor Seat



Piantedosi Sliding Seat Stop



Alden Fixed Seat on erg



Alden Fixed Seat Erg Spacers

Custom Fixed Seats and Adaptations

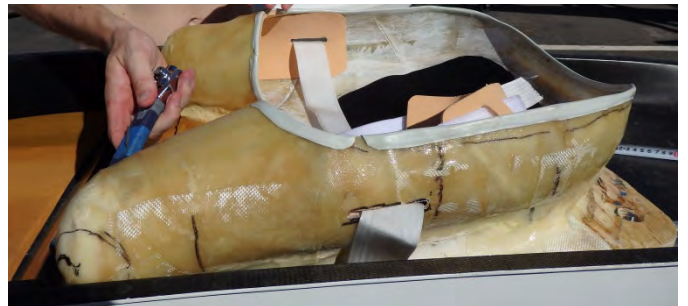

Equipment – Pontoons



Swift Pontoon



Rowing Revolution Pontoon and Brackets



Alden Pontoon Bracket



WinTech Pontoon and Bracket

Equipment – Strapping



FISA Strapping Requirements

- Must be a minimum of 50mm wide, without mechanical buckles, of non-elastic material, and able to be released with a single quick-hand action or mouth.
- Has to be in contrasting color of rowers racing uniform with pull-tab and opening in same direction for all straps.
- Chest strap must be orientated horizontally to water, with top of working edge at just the xiphoid process.
- Chest strap must be tightened so shoulder blades touch the seat back and restrict movement but not breathing.
- Two-point attachment to prevent pivoting (chest)
- Knee strap must be secured under the seat, seat extenders or tracks and be as close to the knee as possible.
- Hand grip aids strapping must be able to be released quickly by mouth



Xiphoid Process Circled in Red

Strapping Examples



Fixed Seat Strap Extenders



EQUIPMENT – Boat Drop-in Rigs



Piantedosi Row Wing



Alden Oarmaster

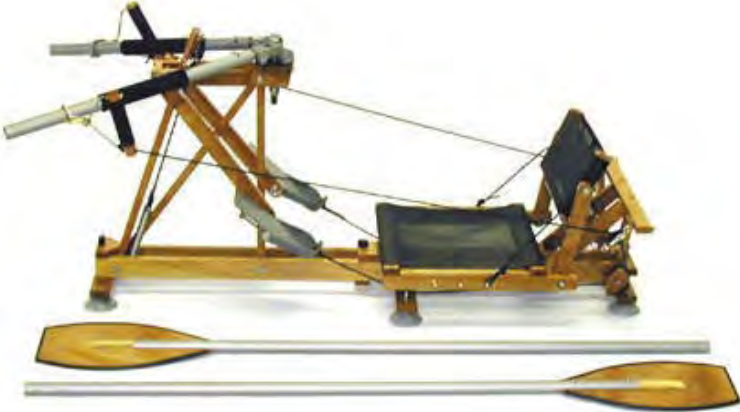

Rontilla Front Row System – Para



Piantedosi Dock System



Alden SUP sliding rigger

Equipment – Grip Aids



Active Hands Grip Aid



Oarsome Grips



Stick Taped to Grip

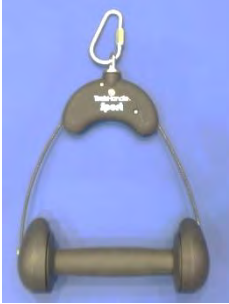

D-ring for Single-arm Amputee



Specialized Arm Prosthesis

Equipment – Seat Track Amendments

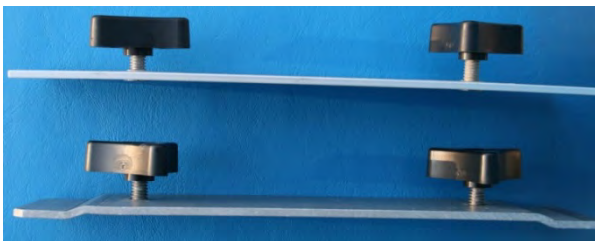

Alden Track Adaptors

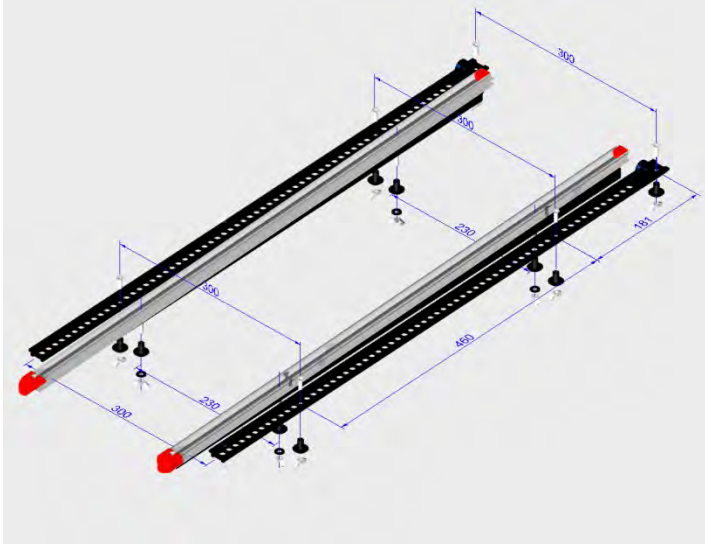

WinTech Track Adaptors
– Fixed to sliding

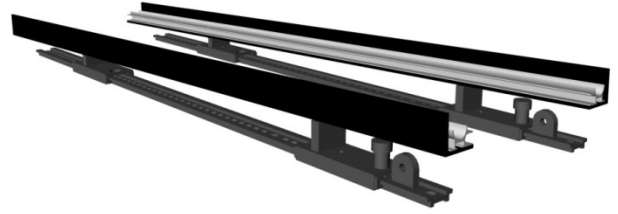

Equipment – Oarlocks

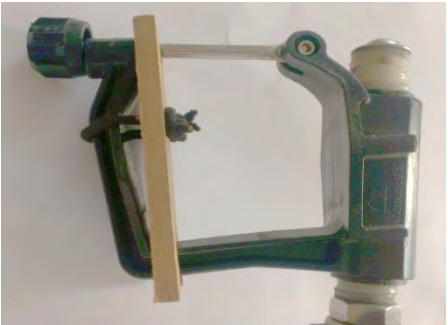

Feather Locks, Alden and Homemade

Equipment – Foot Adaptations



Carved block allows fixed angle to rotate.



Homemade Slide Stop with Bumper

Equipment – Padding for support



Equipment – Seat Pads

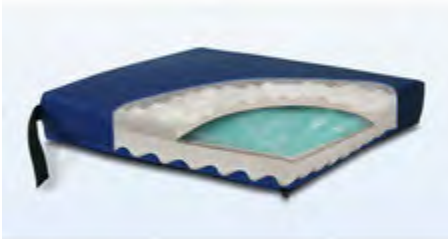

Gel Pad



Air Cell Roho™ Seat Cushion



Lumbar Support Seat



Jay Protector™ Pads for Buttocks



Vicair Allrounder™

Equipment – Transfer Options



(Romain Dido/Cyril Fournier- France 12/09)

Self-transfer Station

Transfer Box Design

- 2-step box should be solid or attached to each other, so they don't separate during a transfer.
- Step one is 19" tall. Top surface is 18" deep by 26" wide.
- Step down is 9" tall. Handle holes cut out for carrying.
- Cover the tops with 1" padding and vinyl cover.

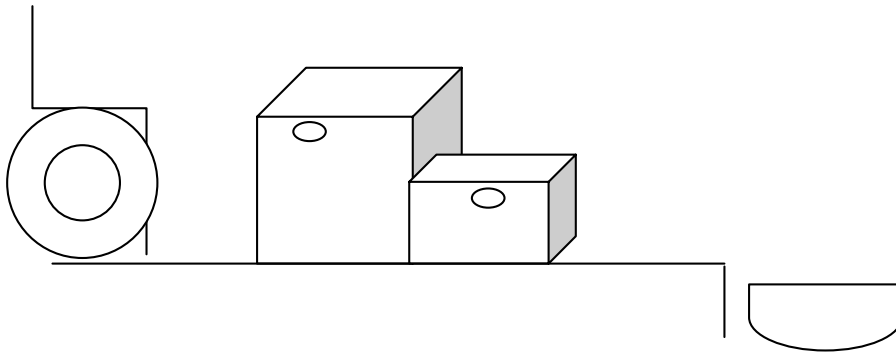

Additional Transfer Options



Equipment – Communication Aids



Eartec SLT24G2CYB – Marine Captain to Crew Simultalk 24G Radios

(1 Master SLT24M, 1 Remote SLT24R) w/ Qty. 2 Cyber Headsets (CYB24G)
• Intercom • Handheld • 2.4GHZ • 2-Users

Toll-Free 877-412-3738

AKA: SLT24G2CYB

Approximately 75 Feet.

Cell Phone (Programmed!) & Waterproof Case



Blue Ant Sport Buds – Work with Bluetooth Technology

Communication Aids – Software

Several software programs are available for use with **Concept2** Performance Monitors. Be sure to review the system requirements for each software program to ensure that the software is compatible with the Performance Monitor and the program's equipment.

ErgChatter is free PC software that gives a voice to the Performance Monitor (PM). When using the indoor rower or SkiErg, ErgChatter announces performance data at regular intervals. Visit concept2.com/ergchatter for full details and to download the software.

ErgData is designed to run on iOS and Android devices. ErgData is a free application that provides additional statistics, stores and displays workout results, and uploads workouts to the Concept2 Online Logbook. If running iOS 7, ErgData will work with the VoiceOver features on the iOS device to announce workout data. Running ErgData requires a connection kit (available from Concept2) to connect the iOS device to the indoor rower or SkiErg.

Note for Android Users: ErgData voice features are available for iOS devices only. The third-party app, [BoatCoach](#), offers voice features for Android devices.

ErgBuddy is an application developed for the iPhone, iPad, and iPod touch. ErgBuddy offers many of the same features as ErgChatter, plus additional capabilities like setting up workouts and more control over what is voiced.

With the release of ErgData, Concept2 is no longer actively developing ErgBuddy; however, ErgBuddy may still be suitable if a Wahoo Key is already owned or if the device cannot be upgraded to iOS 7 to take advantage of ErgData's VoiceOver features. [Learn more about ErgBuddy](#).

[\(<http://www.concept2.com/indoor-rowers/adaptive-rowing/rowing-visually-impaired>\)](http://www.concept2.com/indoor-rowers/adaptive-rowing/rowing-visually-impaired)

Boat Coach is performance software for rowing and erging. (<http://www.boatcoachapp.com>)

BoatCoach is a free Android phone application for athletes who row or Concept2 erg.

The main features include:

- Display stroke rate, distance, speed, elapsed time, calories, heart rate, etc.
- Built-in graphs
- Logbook to store workouts
- Programmable workouts with simple graphical wizard
- Ergout game for Concept2
- Stroke analysis for rowing
- Customizable user interface
- Supports sweeps, sculls, kayaks, dragon boats, and Concept2 ergs

BoatCoach uses the phone's built-in sensors, so no wires are required.

PROGRAMMING

Sample Adaptive Rowing Schedule

Approximately 16 athletes per practice

- Tuesday 3:30-5:30 p.m. Fixed-seat boats, fewer athletes
6-8 p.m. Mix of abilities
- Thursday 6-8 p.m. Mix of abilities
- Saturday 11 a.m.-1 p.m. Dragon Boating
- Sunday 9-11 a.m. Focus on 4+

(Sculling & Sweep Rowing at Three Rivers Rowing, Pittsburgh, Pa.)

On-Water Session

A typical rowing session starts with the rowers gathering their rowing gear together, which might include a water bottle, seat pad, grip aids and a cell phone in its waterproof case. After checking in with the coach and talking about the practice goals, the rower is assigned to a coach or volunteer. Any guide animals or mobility equipment not used to row is secured on land.

The rower assists with carrying oars, pontoons and seat pads – even the boat – as physically able to the dock. The rower self-transfers or is assisted into the boat. The entire session from arrival to departure runs from 30 minutes to two hours, depending on the ability of the rowers in the session. After returning to the dock, the rower waits at the dock for a volunteer to bring his or her mobility equipment or service dog back to the dock.

The rower assists with retuning the equipment to storage as is able and is assisted back to the club by a volunteer, if needed. The athlete checks out with the coach and is updated on upcoming competitive, educational or social opportunities at the club. This information should be sent electronically (or a hard copy to share with aids or family members if the rower doesn't have a computer) to all athletes in the program.

VOLUNTEERS

The volunteer is the “*life blood*” of the adaptive rowing program. Volunteers may come from within the club, may be a family member or friend, or even a health professional from the community. Careful consideration needs to be taken to pair an appropriate volunteer with the adaptive rower. This relationship can last for some time and a special connection will reap rewards for both people in the long term. The role of the volunteer is to assist with transfers in and out of the boat, logistics, training and coaching, and carrying equipment. Sometimes, it is important for the volunteer to simply be with the family member and help answer questions. Occasionally, the volunteer is called upon to row with the athlete from the bow position and guide the boat, or assume the role of coxswain and steer a sweep boat from the stern.

Volunteer Training Checklist

❖ Working with athletes

- Sensitivity training
- Guiding VI athletes
- Coaching tips

❖ Safety

- Athlete safety
- Dock safety
- Water safety
- Safe Sports Program

❖ Equipment

- Where is where?
- How to set up for practice/athletes?

❖ Practice

- Goals for practice
- Typical schedule
- How to approach workouts
- Logistics
- Signing in/out for practice
- What information to share with coaches

Volunteer Support

For long-term success, it is important to find dynamic people. Make the effort from the start to provide the best in adaptive training. (USRowing provides free educational seminars upon request). Mentor the volunteers and show value for their input. Include volunteers in all of the rowing club social activities.

Creative ideas for keeping volunteers happy include providing a volunteer t-shirt or hat with the club logo, offering kneepads, and endless drinking water during the sessions for which they volunteer.



Sample Volunteer Application

SEAS Volunteer Application

1

the SEAS INITIATIVE

Southeastern Adaptive Sculling

@Atlanta Rowing Club

Atlanta Rowing Club | P.O. Box 500937 | Atlanta, GA 31150-0937 | adaptive@atlantarow.org

Name: _____ Date: _____
Street Address: _____
City, State, Zip: _____
Phone Number: _____ Alt. Phone Number: _____
Email: _____ Date of Birth: _____

How did you hear about us? _____

Are you a member of the Atlanta Rowing Club? (Please mark one) Yes No

Sports Experience

Do you have experience rowing? (Please mark one) Yes No

If yes, please provide us with more detail:

e.g. where did you row, for how long, was it competitive, masters, learn-to-row

Does your experience include: (Please mark all that apply) Port Starboard
 Sweep Sculling

Types of Volunteering You Enjoy

- | | |
|--|---|
| <input type="checkbox"/> Carpentry, Construction, etc. | <input type="checkbox"/> Community Outreach |
| <input type="checkbox"/> Dock Assistance | <input type="checkbox"/> Launch Driver |
| <input type="checkbox"/> Marketing | <input type="checkbox"/> Rowing Assistance |
| <input type="checkbox"/> Special Events | Other: _____ |

INTERNAL USE ONLY
Date Received:

Received By:

(From Southeast Adaptive Sculling, Atlanta, Ga.)

Volunteer Application – Page 2

SEAS Volunteer Application

2

Medical Experience

Are you a certified medical professional? *(Please mark one)* Yes No

If yes, please describe:

Please note that you may be asked to provide a proof of certificate.

Do you have current certification for any of the following: *(Please mark all that apply)*

- | | |
|---|-------------------------|
| <input type="checkbox"/> Automatic Electronic Defibrillator (AED) | Date of Training: _____ |
| <input type="checkbox"/> Cardiopulmonary Resuscitation (CPR) | Date of Training: _____ |
| <input type="checkbox"/> First-Aid | Date of Training: _____ |

Availability

We will not ask you to be available every week at each of the times indicated.
Mark those times that you are *most* available to volunteer. *(Please mark all that apply)*

Weekday Evenings (6:30P – 8:30P)

Mon Tues Wed Thurs Fri

Weekends (Times designated below)

10:00A – 12:00P	<input type="checkbox"/> Sat	<input type="checkbox"/> Sun
12:00P – 2:00P	<input type="checkbox"/> Sat	<input type="checkbox"/> Sun
2:00P – 4:00P	<input type="checkbox"/> Sat	<input type="checkbox"/> Sun
4:00P – 6:00P	<input type="checkbox"/> Sat	<input type="checkbox"/> Sun

Please provide any additional information about your willingness to volunteer:

Who can volunteer? Where to find them?

First, start with the organization/boathouse itself. Members are a valuable resource in terms of expertise and resources. A simple email blast asking members for help with marketing, promotion or even construction skills can provide a wealth of expertise. Eventually, programs will need a couple of people who can do medical and technical classification, so check with club members or community medical experts to see if they might be willing to volunteer some time to become certified.

High school and college students are often required to perform community service work or volunteer for a school degree, and what better way than helping an adaptive rowing program. If the organization has a scholarship program, those recipients might be willing to give back in the way of volunteer hours. If the program is affiliated with a local medical facility, such as a VA or outpatient rehab center, those physicians, physical and rec sport therapists might be able to support your program. Lastly, an important aspect of rowing for the adaptive athlete is being able to share the sport and involve a family member with this activity. Engage them as volunteers, if they are willing.



It is very important to track and record volunteer hours for grant applications. TTRA Adaptive Rowing Program volunteers logged over 750 hours for 53 days of programming from May-October @ \$22.14/hr = \$16,605 worth of time!

Volunteer Hours – Record Keeping

GrantSpaceSM, a service of the Foundation Center, offers information and resources that are specifically designed to meet the needs of nonprofits worldwide in need of know-how for securing funding and operating effective organizations.

What is the monetary value of volunteer time?

Answer: The estimated value of volunteer time for 2013 is \$22.55 per hour, according to the Independent Sector, a coalition of charities, foundations, corporations and individuals that publishes research important to the nonprofit sector. It reports annual statistics on the estimated dollar value of volunteer time, including historical values back to 1980 and values for each state. (Note: there is a lag of almost one year in the government's release of data.)

More statistics on volunteers in the U.S. and abroad can be found on Energize, Inc.'s Statistics on Volunteering page.

Nonprofits typically use the value of volunteer time to demonstrate the support they receive from their communities. Independent Sector advises that if the organization plans to report the value of volunteer services in external financial statements, including grant proposals, they will need to follow generally accepted accounting principles (GAAP), established by the Financial Accounting Standards Board (FASB), which state:

Contributions of services shall be recognized, if the services received:

- *Create or enhance nonfinancial assets; or*
- *Require specialized skills, are provided by individuals possessing those skills and would typically need to be purchased, if not provided by donation. Services requiring specialized skills are provided by accountants, architects, carpenters, doctors, electricians, lawyers, nurses, plumbers, teachers and other professionals and craftsmen.*

Per the IRS, nonprofits may not report volunteer time as contributions in line 1 of Parts II or III of Form 990, Schedule A. It may be described in Form 990, Part III, *Statement of Program Service Accomplishments*.

America Rows affiliates or programs that are part of a rowing club may apply for grants through their club as long as it has this tax-exempt status. If they are just forming a club, they may apply for grants through a friendly, usually local, fiscal sponsor, or an organization that already has nonprofit status with the IRS and agrees to serve as a fiscal sponsor. The fiscal sponsor will usually retain a small percentage of the grant for fiscal management costs. Most funders will want to see a fiscal sponsor agreement in place between the rowing program and the fiscal sponsor. It can take three months to a year to be approved as a new 501(c)(3) organization.

<http://grantspace.org/tools/knowledge-base/Nonprofit-Management/Employment-Volunteering/monetary-value-of-volunteer-time>

Programming – Non Profit Process

These documents are not a substitute for legal advice or expertise. It is up to the applicants to seek legal assistance or advice as needed.

Applying to Become a 501(c)3 Nonprofit – Basic Steps



STREAMLINE AND GET STARTED FASTER

Note: If an organization expects gross receipts of less than \$50,000 over a 36-month period, it can fill out the streamlined Form 1023-EZ for establishing nonprofit status in approximately less than one year. This can be done to get started, and as the program grows, a CPA can convert for tax reporting later. Refer to end of section.

- Read the attached IRS instruction document on how to become a 501(c)3.
- Some organizational founders hire lawyers to complete the application, and some fill out the applications themselves and may get it checked by a development or legal professional before submitting it. Some pay for services such as www.legalzoom.com/nonprofit, www.501c3.org or www.charitynetusa.com, but this may not be necessary.
- Go to the local IRS office, call or go online to www.irs.gov and download the nonprofit 501(c)3 application form 1023 at: <http://www.stayexempt.irs.gov/StartingOut/InteractiveForm1023Application.aspx>
- Establish an IRS Tax ID-Employee Identification Number (EIN) number (go to: <http://www.irs.gov/Businesses/Small-Businesses-&-Self-Employed/How-to-Apply-for-an-EIN>)
- Organize documents before applying: assemble a board, the organization's financials and outcomes expected.
- Expect it to take approximately three to six months, even a year, to receive a response.

Exempt organizations - organizing documents

Each application for exemption must be accompanied by an exact copy of the organization's organizing document: Articles of incorporation for a corporation, articles of organization for a limited liability company, articles of association or constitution for an association, or trust agreement or declaration of trust for a trust. If the organization does not have an organizing document, it will not qualify for exempt status.

If the organization's name has been legally changed by an amendment to its organizing documents, also attach an exact copy of that amendment to the application. State law generally determines whether an organization is properly created and establishes the requirements for organizing documents.

State Links

What's Available Here - Determine your state's registration requirements.

Below is collection of links to state government websites with useful information for tax-exempt organizations. Whether you are already operating or just starting, there is something here for you.

Visit the state web sites below and find information on state registration requirements for charities, taxation, information for employers, and more.

- [Alabama](#)
- [Alaska](#)
- [Arizona](#)
- [Arkansas](#)
- [California](#)
- [Colorado](#)
- [Connecticut](#)
- [Delaware](#)
- [District of Columbia](#)
- [Florida](#)
- [Georgia](#)
- [Hawaii](#)
- [Idaho](#)
- [Illinois](#)
- [Indiana](#)
- [Iowa](#)
- [Kansas](#)
- [Kentucky](#)
- [Louisiana](#)
- [Maine](#)
- [Maryland](#)
- [Massachusetts](#)
- [Michigan](#)
- [Minnesota](#)
- [Mississippi](#)
- [Missouri](#)
- [Montana](#)
- [Nebraska](#)
- [Nevada](#)
- [New Hampshire](#)
- [New Jersey](#)
- [New Mexico](#)
- [New York](#)
- [North Carolina](#)
- [North Dakota](#)
- [Ohio](#)
- [Oklahoma](#)
- [Oregon](#)
- [Pennsylvania](#)
- [Puerto Rico](#)
- [Rhode Island](#)
- [South Carolina](#)
- [South Dakota](#)
- [Tennessee](#)
- [Texas](#)
- [Utah](#)
- [Vermont](#)
- [Virgin Islands](#)
- [Virginia](#)
- [Washington](#)
- [West Virginia](#)
- [Wisconsin](#)
- [Wyoming](#)

Form 1023, Application for Recognition of Exemption Under Section 501(c)(3) of the Internal Revenue Code

This form is used to apply for recognition as a tax-exempt organization under Section 501(c)(3).

Note: An organization may be eligible to file Form 1023-EZ, a streamlined version of the application for recognition of tax exemption. Complete the Form 1023-EZ Eligibility Worksheet in the Instructions for Form 1023-EZ to determine if the organization is eligible to file this form. If not, file Form 1023 (or Form 1023, Interactive) below.

An IRS interactive guide will help to correctly complete and submit IRS Form 1023. Use these “prerequisite questions” to ensure the organization has everything needed to apply for tax exemption using Form 1023, Application for Recognition of Exemption, and its associated schedules. After the questions, download the Form 1023 Checklist to track the required documents, then download the Interactive Form 1023. Please read all content provided to ensure the requirements for tax-exempt status are understood. Before starting, note that certain organizations may be eligible to apply using Form 1023-EZ instead. Go to the 1023-EZ page for details.

START HERE:

<http://www.stayexempt.irs.gov/StartingOut/InteractiveForm1023Application/Step1of7.aspx>

Before Applying for Tax Exempt Status

State law governs nonprofit status, which is determined by an organization's articles of incorporation or trust documents. Federal law governs tax-exempt status. The Internal Revenue Code specifically refers to exemption from federal income tax.

Below are the steps to take before applying for tax-exempt status:

1. Determine if the organization is one of the following:
 - Trust
 - Corporation
 - Association
2. Gather organizational documents
3. Determine state's registration requirements
4. Obtain an employer ID number (EIN) for the new organization

Other Resources

Publication 1635, *Understanding Your EIN* Publication 557, *Tax-Exempt Status for Your Organization* Employer ID Numbers (EINs)

Applying for Tax Exempt Status

After following the steps outlined above, the organization needs to determine its type of tax-exempt status.

501(c)(3) – Charitable, Religious and Educational Organizations

- Form 1023-EZ
- Interactive Form 1023
- Form 1023
- Instructions for Form 1023

501(a) – Other Non Profit or Tax-Exempt Organizations

- Form 1024
- Instructions for Form 1024

Other Resources

- Publication 4220, *Applying for 501(c)(3) Status*
- Publication 557, *Tax-Exempt Status for Your Organization*
- Top Ten Tips to Shorten the Tax-exempt Application Process
- Sample Questions
- Can the IRS Expedite My Application?
- Group Exemptions
- Determinations Guide Sheets
- Life Cycle of an Exempt Organization
- Power of Attorney

Training Tools

- Applying for Tax Exemption An Overview

Current Products

Form 1023, Interactive version of Form 1023, Application for Recognition of Exemption Under Section 501(c)(3) of the Internal Revenue Code, includes helpful hints and links to help applicants submit a complete application.

Form 1023 Standard PDF version of the Application for Recognition of Exemption Under Section 501(c)(3) of the Internal Revenue Code. It does not include helpful hints and links to information on IRS.gov. Instructions for Form 1023 (HTML)

Accessible Form 1023 Accessible version of Form 1023, Application for Recognition of Exemption Under Section 501(c)(3) of the Internal Revenue Code.

Recent Developments

Package 1023, Application for Recognition of Exemption Under Section 501(c)(3) of the Internal Revenue Code, was discontinued. -- 12-SEP-2014

Clarification to Form 4506-A, Request for Public Inspection or Copy of Exempt or Political Organization IRS Form (Rev. August 2014) -- 15-AUG-2014

Update to the Instructions for Form 1023-EZ, Part I, line 8. -- 05-AUG-2014

Other Items You May Find Useful:

- All Revisions for Form 1023
- Notice 1382, Changes for Form 1023
- Form 1023-EZ, Streamlined Application for Recognition of Exemption Under Section 501(c)(3) of the Internal Revenue Code
- Other Items Related to Form 1023

Other Current Products

- Comment on Form 1023

Use the Comment on Tax Forms and Publications web form to provide feedback on the content of this product.

CAUTION: The IRS does not respond to tax-related questions submitted using this page. Instead, please visit Tax Law Questions or call their toll-free number at 1-800-829-1040 (Individuals) or 1-800-829-4933 (Business).

Tax Information for Charities and Other Non-Profits

Applying for Tax Exempt Status Information about how to apply for IRS recognition of tax-exempt status.

Annual Reporting & Filing 990-series forms, requirements, and filing tips

Revoked? Reinstated? Learn more information about the automatic revocation process and how to be reinstated.

EO Select Check Search for a tax-exempt's status.

Educational Products, Workshops and Seminars for Exempt Organizations: IRS programs and materials for non-profit organizations.

How to Stay Exempt Resources for tax-exempt nonprofit organizations.

Stay Exempt.IRS.gov: Tax basics for exempt organizations

About Us: General information and how to contact the IRA.

IRS Publication for applying for a 501(3)c status

<http://www.irs.gov/pub/irs-pdf/p4220.pdf>



GRANT WRITING CHECKLIST

1. BECOMING GRANT READY: PART I, GET ORGANIZED INTERNALLY

- Identify your grant writing team, 3-4 people. This always requires support of senior management. Is the CEO behind this effort? Is there a good writer on staff or volunteering with your organization?
- Write down and prioritize your club's critical needs before looking for funding sources; needs assessments are both specific to your organization and its members/people you serve (internal) and also those needs that are specific to the wider community (external). Know where there are gaps in programs and services.
- Who is the applicant? Need 501(c)(3) nonprofit status or a Fiscal Sponsor. Obtain a copy of your club's IRS 501(c)(3) letter of determination or formal Fiscal Sponsor agreement. Know your organization's EIN, Employer Identification Number, assigned by the IRS.
- Gather critical documents that are often requested by funders: e.g. most recent, completed, full year financial statement, audited, if available; your club's current and annual operating budget and your program's current and annual operating budget; description of current programs, program directors, staff, and volunteers, and activities. Have each program director prepare a one-page fact sheet using bullet points on their programs. Prepare short bios on each staff member or key volunteer.
- Gather recent newsletters, clippings, articles, awards and recognitions and know where to find them. Scan and save as PDFs. What are your most compelling success stories? If not written down, write some down. Gather opinions of rowers in writing in an after school academic exercise. Why do your rowers row? What does rowing mean to them?
- Know your organization's mission statement and history. Why does your organization exist? What is its founding story? Same for your program (if different). Why should other people care?

2. BECOMING GRANT READY: PART II, REGISTRATIONS FOR GOVERNMENT GRANTS

- Obtain a Dun & Bradstreet # for your organization. Do this first, if you haven't already: <http://fedgov.dnb.com/webform>
- To become eligible for federal grants, also register with the federal government's System for Award Management (SAM) <https://www.sam.gov>. The POC's (Points of Contact) for your organization are your most trusted individuals, usually a CFO (Financial Officer). Protect passwords— CFO + one other individual should suffice. Make a note of your "MPIN" number.
- Third, register your organization with <http://www.grants.gov/web/grants/home.html> and authorize more than one trusted individual to submit proposals on your organization's behalf. Protect those passwords also.
- The entire process, to become eligible to receive federal funds, takes longer than you think. Start this process at least 6 weeks to 2 months before applying for a grant opportunity via grants.gov. Take it one step at a time and you'll get through it. Keep your passwords in a safe place.

3. WHAT ARE KEY PARTS OF A PROPOSAL? GET STARTED

- History**
- Accomplishments**
- Current Programs and Activities**
- Target Population**
- Partnerships**
- Needs Statement**
- Program Design
- Management Plan
- Evaluation Plan
- Budget (Program specific)
- Organizational Structure/Administration
- Finances (Organizational)
- Support Material**
- TO START: Write one-half page on each ** topic and circulate for comment among your team and other invited reviewers, including parents, rowers, and volunteers. Be inclusive!

4. RESEARCH FUNDING SOURCES FOR YOUR CLUB

- Visit The Foundation Center's website <http://foundationcenter.org/>, click Get Started in the banner on top and explore. Also try their FREE online courses, e.g. <http://foundationcenter.org/getstarted/learnabout/proposalwriting.html>
- Browse Youth grant opportunities. Here is one recent example in Michigan: <http://philanthropynewsdigest.org/news/mottfoundation-awards-2.8-million-for-afterschool-programs-in-flint>
- Here is a link to the top 50 foundations that provided funding for children and youth in 2011: http://data.foundationcenter.org/#/fc1000/population_group:children_youth/all/top:foundations/list/2011
- Find the Foundation Center's nearest satellite information center to your program and research current grant opportunities for FREE. This is a tremendous public resource. Here is a link to find the one closest to you: <http://foundationcenter.org/find-us.html> Most, if not all, centers will teach you how to access their data bases. Target the funders closest to your club and community: the vast majority of foundations focus their giving on the communities in which they are located.
- Match funders' priorities with yours: only apply for "perfect matches" – don't force a match, find a better one. Contact program officers directly to discuss and take their advice.

5. TO LEARN MORE

- Request draft grant boilerplate (text) and a spreadsheet of grant opportunities prepared for America Rows affiliates to help launch your grant writing efforts.
- USRowing's grant writer, Jennifer Kierstead, is happy to send all USRowing member workshop attendees her presentation materials, including a master Grant Ready checklist, after 12/4.

Send your email request to: jennifer@usrowing.org.

Granting Organizations

Adaptive Sports Fund

www.adaptivesportsfund.org

The Adaptive Sports Fund (ASF's) main objective is to raise funds that will allow them to purchase the necessary adaptive sports and recreational equipment. Furthermore, ASF aims to provide grants to individuals for various adaptive sports equipment; as well as adaptive sports prosthetics to aspiring athletes. This way, ensuring that all people with physical disabilities can live life without limitations.

HeadNorth Foundation

www.headnorth.org

Works with people surviving spinal cord injuries.

5333 Mission Center Road, Suite 115

San Diego, California 92108

Phone: 619-814-1236

High Fives Foundation

www.HighFivesFoundation.org

****Greater San Diego County ONLY**** The Thrive Program offers "Response TWO" financial assistance to help purchase necessary equipment and services to promote an active and productive lifestyle. Grant funding can be used toward wheelchairs, exercise equipment, computers, car and home modifications and physical therapy

PO Box 3212

Truckee, California 96160

Phone: 530-562-4270

The High Fives Foundation is dedicated to raising money and awareness for athletes that have suffered a life altering injury while pursuing their dream in the winter action sports community.

220 Park Road North, Building 7

Wyomissing, Pennsylvania 19610

Phone: 877-595-3505

IM Able Foundation

www.getupandmove.org

IM ABLE Grants are awarded to disabled individuals and supporting organizations and provide hand-cycles, adaptive skis and instructional training programs for those in need. Their purpose is to unleash the potential in physically challenged children and adults to be more active, enjoy the benefits of physical fitness, and spend more time in the great outdoors.

7 Aspen Drive

South Burlington, Vermont 05403

Phone: 802-846-5298

Kelly Brush Foundation

www.KellyBrushFoundation.org

The Kelly Brush Foundation is a 501(c)3 non-profit organization dedicated to: advocating for improving ski racing safety, supporting research to treat and cure paralysis due to traumatic spinal cord injury (SCI), improving the quality of life for individuals living with SCI by purchasing adaptive athletic equipment for those with financial limitations, and supporting the U.S.

Adaptive Ski Team.

25455 Barton Road, Suite 109A

Loma Linda, California 92354

Phone: 909-558-6384

Team Possabilities

www.TeamPossabilities.org

The purpose of a PossAbilities grant or scholarship is to provide support for their members to improve the quality of life, assist in the reintegration of those with disabilities into the community and society, and to meet the specific needs of their members.

30398 Esperanza

Rancho Santa Margarita, California 92688

Phone: 949-635-1970

SCI Special Fund

www.scispecialfund.org

The Mission of the SCI Special Fund is to help California residents with spinal cord injuries maximize their independence in order to achieve life-changing results.

University of Southern California

3501 Watt Way

Heritage Hall MC 203A

Los Angeles, California 90089

Phone: 213-740-4155

Swim with Mike

www.swimwithmike.org

The USC Physically Challenged Athletes Scholarship Fund. The goal is to help pave the way for individuals to overcome their tragedies and strive for a brighter future. Founded and hosted at the University of Southern California since 1981.

18307 Oakmont Drive #931

Canyon Country, California 91387

Triumph Foundation

Phone: 661-803-3700

www.triumph-foundation.org

Triumph Foundation is a 501c(3) non-profit organization whose mission is to help individuals with Spinal Cord Injury triumph over their disability and to inspire them to keep moving forward with their lives by pushing themselves to get better every day. Triumph Foundation works to minimize the obstacles that one faces after suffering Spinal Cord Injury. They specialize in galvanizing and restoring lives after Spinal Cord Injury (SCI).

PO Box 66

Fox Lake, Illinois 60020

Phone: 888-788-NAIDW

National Association of Injured and Disabled Workers

www.naidw.org

NAIDW is a nationally recognized 501 (c) (3) public charity whose purpose is to provide unlimited resources, support, guidance and short-term financial assistance to injured and disabled workers and their families as a result of injury, illness, pain or disability.

290 Callaway Avenue
Pensacola, Florida 32505
Phone: 562-447-4235

The Independence Fund

www.independencefund.org

The Independence Fund's mission is to provide the tools, therapies, and guidance that those veterans severely injured in the Line of Duty are otherwise not receiving. The Independence Fund is an entirely 100%, all volunteer non-profit, whose Board of Directors is comprised entirely of combat veterans.

4393 Kevin Walker Drive, PMB 159
Dumfries, Virginia 22025
Phone: 202-412-0611

America's Fund

www.americasfund.org

America's Fund is a program created to direct urgently needed resources and financial support to injured and critically ill members of the U.S. Armed Forces and their families. This is a program of the Semper Fi Fund, an established 501(c)(3) nonprofit with an A+ rating from the American Institute of Philanthropy and a four-star (highest possible) rating from Charity Navigator. Since its inception in 2004, the Semper Fi Fund has provided more than \$76 million in support.

825 College Blvd, Suite 102-PMB 609
Oceanside, California 92057
Phone: 202-772-1081

Semper Fi Fund

semperfifund.org

The Semper Fi Fund (SFF) provides relief for financial needs that arise during hospitalization and recovery, as well as assistance for those with perpetuating needs. The program provides support in a variety of ways including service member and family support, specialized and adaptive equipment, adaptive housing, adaptive transportation, education and career transition assistance, PTS and TBI support, Team Semper Fi, and America's Fund.

PO Box 251255
Los Angeles, California 90025
Phone: 323-655-8298

SCORE

www.scorefund.org

SCORE aims to assist young people who have been injured while participating in sporting events or athletic recreation. SCORE endeavors to improve the quality of life for people with a spinal cord injury, assisting with the substantial out-of-pocket costs associated with obtaining the best medical care, home amenities and transportation. The end goal is to facilitate rehabilitation and independent living.

PO Box 975

Cheetowaga, New York 14225

Wheels with Wings

www.wheel-withwings.org

Wheels With Wings can provide financial support to individuals who have suffered a spinal cord injury and are in need of services or equipment. From wheelchairs to vehicles and home modifications to rehabilitation, Wheels With Wings offers grants for those in need.

5333 Mission Center Road, Suite 115

San Diego, California 92108

Phone: 619-814-1236

ThreeSixtyFive Foundation

www.threesixtyfivefoundation.org

It is the mission of the ThreeSixtyFive Foundation to provide, through financial and non-financial means, assistance to physically challenged individuals in returning to an active lifestyle during the first year of their recovery.

PO Box 1324

Greenwood, Indiana 46142

The Honor Group

www.thehonorgroup.org

The Honor Group has built an alliance with the philanthropic community, faith-based organizations and school districts. Their vision encompasses all branches of the military. Their values are rooted in the tradition of generosity, loyalty and honor. They are a group of individuals and like-minded people who leave a legacy of hope every place they go. They provide practical help for those re-entering civilian life.

605 Poplar Court

Granite Bay, Ca. 95746

(916) 791-3323

Achilles International

<http://www.achillesinternational.org/>

Achilles' original programs, their chapter workouts and races, have grown over the years to include participation in marathons throughout the world, as well as their signature 5M Hope and Possibility Race. In that time, they have developed two very unique specialized programs to serve children with disabilities and injured war veterans. Their Achilles Kids program provides training, racing opportunities, and an in-school program for children throughout the U.S. Their Freedom Team of Wounded Veterans program brings training, access to specialized equipment and marathon opportunities to disabled U.S. military veterans. Although all of their programs focus on athletics, the truth is, sports are simply the tool for accomplishing

their main objective: to bring hope, inspiration and the joys of achievement to all people with disabilities.

Achilles International
42 West 38th Street, Suite 400
New York, NY 10018
212-354-03002

Challenged Athlete Foundation

<http://www.challengedathletes.org>

It is the mission of the Challenged Athletes Foundation® (CAF) to provide opportunities and support to people with physical challenges, so they can pursue active lifestyles through physical fitness and competitive athletics. CAF believes that involvement in sports at any level increases self-esteem, encourages independence and enhances quality of life.

Challenged Athletes Foundation
9591 Waples Street
San Diego, CA 92121
858.866.0959

Christopher & Dana Reeve Foundation

<http://www.christopherreeve.org>

The Reeve Foundation is dedicated to curing spinal cord injury by funding innovative research, and improving the quality of life for people living with paralysis through grants, information and advocacy.

636 Morris Turnpike
Suite 3A
Short Hills, NJ 07078

Rigging for Adaptive Boats

LTA (Leg, Trunk and Arms) Considerations

Crew: Mixed gender (height, strength, length of stroke), mixture of disabilities

Individual: Functional range of stroke, use of prosthetics or orthotics-balance and stroke

TA (Trunk and Arms) and AS (Arms and Shoulders) Considerations

Due to the fixed seat, the geometry of the stroke changes dramatically to maximize the stroke.

Crew: Mixed gender (height, strength, length of stroke), mixture of disabilities

Individual: Functional range of stroke, use of prosthetics or orthotics-balance and stroke

Rigger/Oarlocks

- Oarlock height over seat height
- LTA: no special considerations
- TA: slight narrower span, deeper chevron
- AS: narrow span, deeper chevron

Seat

- Height of rower with seat padding
- Back frame angle adjustment (removed, slight, upright, to angled aft)

Pontoons

- Encourage rowers to progressively lift pontoons off the water.
- TA rowers with good trunk stability should eventually row without pontoons

Oars

- TA- Slightly shorter inboard, minimal cross over
- AS- Greatly reduced inboard, no cross over

Rigging

With the advent of fixed-seat rowing, it was immediately clear that because of the shorter stroke, there was no need for overlap of the handles. The first thing that was changed was to increase the spread on a standard rigger as much as possible and move the collar on the oar to get the shortest inboard allowing for non-crossing sculls. Depending on the equipment, this could mean a spread of 163cm, inboard of 78cm, and overall oar length of 285cm. Though it makes for an extremely heavy load, rowers are able to have longer strokes instead of a quick drop in the water.

For AS rowers, the goal is to increase the arc that the oar follows through the water. AS rowers have a short stroke, so a short inboard is needed. They also require a smaller spread, so custom riggers can be made with spreads as low as 125cm. The angle of the rigger out to the pin is smaller, allowing the rower to reach further through the pin and achieve a larger catch angle. Without crossover, no differential is needed, so the oarlock heights can be the same.

With standard oars, this type of rigging is generally not possible without moving the sleeve, and because of the length of the oar, it is too heavy for racing. Consider purchasing shorter oars with larger blades to create a lighter load and thus achieving higher stroke rates to race 1,000m (see figure 15.7). An AS or TA rower using a non-crossing oar would want at least 8cm space between the ends of the handles. For example, 140cm spread would require a maximum of 66cm inboard (see figure 15.8).

ASM1x at Entry



Figure 15.7



Figure 15.8

(The following is an excerpt from the second edition of *Rowing Faster (Human Kinetics, 2011)*, edited by Volker Nolte. This excerpt comes from Chapter 15, "Special Considerations for Adaptive Rowing," written by Karen M. Lewis.)

2014 USA Adaptive Rowing Rigging Standards				
Examples of Rigging Ranges Used by 2008 U.S. Paralympic Rowing Team				
Boat class (country)	Blade Type	Spread/span	Inboard (cm)	Overall length (cm)
ASM1x (USA)	Concept 2 Fat Blade	141	66	248
ASM1x (Canada)	Croker	134	61	264
ASW1x (USA)	Concept 2 Fat Blade	143	69	248
TAmix2x (USA)	Concept 2 Fat Blade	147	70	265
LTAmix 4+ (USA)	Concept 2 Fat Blade	84	114	367
Middle-range club rig 4+	Coach choice	86	116	372
<p>In the USA LTA4+, the heights were set higher for the men and lower for the women to accommodate the varying rowers, and one of the athletes was rigged with a longer outboard.</p> <p style="text-align: center;">USA Adaptive Rigging Recommendations for AS and TA Rowers <i>Inboard Rule for AS sculling: divide the spread by 2 and subtract 4cm.</i></p>				
AS (Arms & Shoulders)	C2 Fat	140-145	64-76	248-253
	C2 Smoothie	140-145	64-76	253-258
TA (Trunk & Arms)	C2 Fat	150-155	67-79	273-278
	C2 Smoothie	150-155	67-79	278-283



Adaptive Rowing Technique & Training

The basic technique for adaptive rowing is essentially the same as for rowers without disabilities. Considerations for technique will depend on the athlete's specific disability and how factors such as strength, limb length and flexibility affect the stroke. Feathering the oar blade should be encouraged, as it is much more efficient than rowing "on the square".

It is important to check in with the athlete regularly to get their feedback on comfort and to ensure the adapted equipment is properly fitted to the specific rower. Rowers who use prosthesis must monitor the contact points for any issues that might cause damage to the skin surface and underlying tissue.

Sliding Seat

LTA – The technique is essentially the same as for rowers without disabilities, but style and power application may be modified to account for a specific disability. The stroke rating of the LTA rower is usually under 40 SPM and a LTA rower should be encouraged to start erg training with a drag factor of 105-120. For more info about drag factor, visit <http://www.concept2.com/indoor-rowers/training/tips-and-general-info/damper-setting-101>.

Fixed Seat

The fixed seat changes the geometry of the stroke dramatically. The travel of the oar is reduced, so it is important to have efficient blade entry and exit to maximize the length of the stroke. The fixed seat and additional strapping at the knees, lap or chest will transfer the forces of rowing, usually accommodated by the larger muscle groups and joints, to smaller muscle groups and joints. Fixed-seat rowers also row at a higher stroke rating which increases stress to these areas – specifically the lower back, upper

shoulder, cervical area and ribs. The weight of the boat and length of the race will affect the stress on the fixed-seat rower. Strength and flexibility training need to be established from the beginning, creating a solid foundation to protect the rower from the unique stresses of fixed seat rowing.

TA – The stroke rating of the TA rower is approximately three beats higher than a sliding-seat rower. Erg training is recommended at a drag factor of 125-140.

AS – The stroke rating of the AS rower is approximately six beats higher than a sliding-seat rower – some achieving a rating of over 45 SPM. Erg training is recommended at a drag factor of 150-175. Pontoons, even just touching the water, also will cause increased drag and stress to the AS rower.

To be effective, the AS rower must maximize his or her relatively short range of motion caused by the restriction of the chest strap. The shoulder/thorax region essentially behaves like a pivot point, which places significant stress upon the ribs. Great care needs to be taken to protect the ribs by way of proper padding or a full-length protective orthosis, which serves to distribute the stress point. Proper flexibility and strength training will help avoid overcompensation of adjoining muscles and joints.

Adaptive Rowing Technique – Arms & Shoulders

The rowing stroke has two phases: the **recovery** and the **drive**.

The **recovery** is when the blades are out of the water and the athlete is sliding forward towards the catch. It is defined by the sequence of the motion: hands, body and slide. *The catch is part of the recovery.*

The **drive** phase is when the blades are in the water, and the boat is propelled through the water. It is defined by the sequence of the motion: legs, back and arms.

The first part of recovery



Hands

- The athlete sits in the finish position, with legs slightly flexed (supported if needed) to prevent spasm or potential injury.
- The blades are out of the water.
- The hands start moving away from the body to almost full-arm extension (but not locked).



Body preparation

- The rower straightens the arms and pivots the upper trunk and shoulders forward to the full reach position, “pivoting” against the chest strap.
- Head should remain upright, hands are over the feet. Avoid “diving” at the end of the slide, as it dramatically slows the boat speed.



Catch as part of the recovery

- The rower sits tall, relaxed and maintains the forward body angle, with relaxed arms and shoulders.
- The blade is dropped into the water, locking the blade in the water relative to the speed of the boat.
- The rower is able to suspend his or her weight on the oar handle.



The Back

- The rower “uncoils” the back, swinging the upper trunk and shoulders, with relaxed horizontal forearms. (Care should be taken not to lead with the head.)
- The rower passively hangs on the oar handles, keeping them 2-3” below the water level.
- The arms are still stretched.
- The oars are approaching a position perpendicular to the boat – mechanically, the most efficient part of the stroke.



The Arms or Finish

- The oar handle accelerates in towards the body to the last few inches of the draw.
- The forearm is horizontal to the water, and the elbow pulls past the body.
- The head and body should remain erect with no slouching.



The Release

- The rower keeps a tall body position with the chin level and the chest behind the oar handles.
- The wrists are pushed down slightly in a semi-circular, downwards “tapping” motion.
- Both hands feather the blades using the thumbs and fingers.
- The oar handles slow slightly.
- The blade is released from the water.

FES Rowing Expands Exercise Possibilities for People with Disabilities

Article written by Mark McAndrew, Concept2 Rowing

Longtime hub of competitive rowing, Boston has been both witness and participant in an evolutionary form of the sport known as FES indoor rowing. (See front page Sunday Boston Globe article "[Hope is a River](#)" July 12, 2009)

Indoor rowing was born in the early 1980s when brothers and former rowers Dick and Pete Dreissigacker developed the first rowing ergometer.



Rowing ergometers are pieces of exercise equipment that accurately measure the work/performance done while putting the body through motions and physical demands similar to that of traditional on-water, competitive rowing.

Originally developed to afford on water rowers a sport-specific form of training during colder months, indoor rowing now appreciates worldwide recognition as one of the best sources of fitness exercise for not just rowers, but all folks that regularly use this machine. Indoor rowing requires work by both legs and upper body in a concerted effort, recruiting most of the major muscle groups in the process.

This recruitment of such a high percentage of muscle groups and the volume of oxygen required by those muscles far outpaces the demands of most other established forms of exercise. As a result of this greater demand, various physiological systems adapt to regular training resulting in profound health benefits to consistent users. The key here is that it matters not if the muscle contraction is innervated by an electrical stimulator or by the individual. When the muscle contracts, it produces work and consumes oxygen. The heart and other key

physiological players respond to deliver the needed oxygen. Regular use result in adaptations that have health benefits primarily because crucial intensity levels can be achieved and sustained by individuals with spinal cord injury (or other neuromuscular disorders) using this hybrid form of muscle recruitment.

Back to Boston...on-water rowers became so attached to indoor rowing back in the early 80s that they established a race on the indoor rower called the C.R.A.S.H.-B. Sprints. The acronym stands for Charles River All Star Has Beens. The original 1982 race included about 90 of Boston's rowing elite and has been held every year since. The number and breadth of the participants has grown. In 2013, there were more than 2,200 participants in the one-day event held at Boston University's Agganis Arena. Competitors travel from all corners of the planet to race on the rowing ergometers. ([See photos.](#))

At the 2006 CRASH-B Sprints, Brian Andrews, Ph.D., a professor from Brunel University in the UK, brought two spinal cord injured athletes that were paralyzed below the waist to the Sprints to demonstrate a method that enabled folks with similar SCIs to use the indoor rowing machine. Brian's system, called Functional Electrical Stimulation Rowing, made use of an electrical stimulator to cause contraction of the appropriate leg muscle groups as needed during the exercise. This hybrid form of muscle contraction enabled the SCI subjects to achieve the coordination of upper and lower body to successfully row on the ergometers.

A few years later, Harvard Professor J. Andrew Taylor, Ph.D., the principal investigator for Spaulding's Cardiovascular Research Lab, became interested in furthering Andrews' work with FES Rowing. Taylor has recently received \$2.5 million in funding from the National Institutes of Health to study a homogenous group of individuals soon after a SCI. The preliminary work for this study relied on volunteers from the local on-water rowing community; they helped to devise and fabricate special adaptive seats and to provide input on proper rowing technique.

Dr. Taylor, Boston's rowing community, Spaulding Rehab Hospital and Concept2, Inc., – the company started by the Dreissigacker brothers that manufactures the rowing ergometers – had developed a synergy. Even former Olympic rowers Tom Darling and Gary Piantedosi got involved in equipment development and guidance for proper rowing technique in preparation for the study.

However, aside from the study population, Dr. Taylor recognized that eye-popping benefits could be realized by a population broader than just the study-specific group. Dr. Taylor and Laboratory Director Glen Picard MS laid plans to develop a program that would make this form of exercise available to all qualifying folks, whether or not they fit the specific criteria required by the study. Spaulding administrators were quickly on board when they realized the potential health benefits.

And so, a new program coined "Exercise for People with Disabilities" (ExPD) was initiated in 2009. The ExPD program at Spaulding Rehabilitation Hospital in Cambridge showed phenomenal growth and now has 60-90 participants at any given time and does an approximate average 200 FES rowing sessions per month!

PARALYMPIC ROWING PERFORMANCE PIPELINE



PARA-ROWING – Outline

Initial Involvement to High Performance Para-Rowing

U.S. Para-Rowing athlete development and identification efforts focus on identifying, recruiting, tracking, supporting and retaining world championships and Paralympic-eligible athletes with physical and visual disabilities seeking to become internationally competitive. A key component to the success of the emerging tier of the sport performance pipeline is collaboration between community rowing programs, partner organizations and clubs, military and veteran facilities and USRowing.

Athlete recruitment and identification begins at the local level through military and veteran sport camps, site coordinators, community programs, coaches, technical officials and current athletes. Once a new athlete is identified as having high performance potential, the Director of Para-Rowing will facilitate appropriate communication between athlete(s) and local program(s), as well as with the appropriate high performance coaches. This will include connections to local training resources and participation in select emerging and/or national development camps and competitions and other general rowing opportunities for developing and emerging athletes.

Step 1 (All Levels): If someone is interested in learning more about becoming an athlete who is identified for rowing for the U.S. Paralympic Team, they should complete the athlete questionnaire. Once the questionnaire has been submitted, a member of the USRowing staff will follow up with the athlete to help him or her get connected to a local training program. The questionnaire can be found here: [Paralympic Athlete Questionnaire](#)

Step 2 (Recreational): Find a rowing program close by. If the program has an adaptive program, join it. See list of adaptive programs here: [USRowing Adaptive Programs](#), or look for Paralympic Sports Clubs that offer rowing here: [Adaptive Sport Club Finder](#).

If there is a rowing club locally, as found here: [USRowing Clubs](#), but it doesn't seem to have an adaptive program, talk to the leadership about options to get involved, as many clubs are open to finding a way to get an athlete involved if they are interested and determined. Here are some example workouts to get you started on the ergs.

Adaptive Initial Training Workouts

SPRINT	ANAEROBIC THRESHOLD	AEROBIC
10' warm up. 10x1.5' w/3' rest. Try to hold 1k goal split.	10', 8', 6', 4' w/4' rest b/w pieces. Faster avg. split each piece.	4x10' w/4' rest (SR 22-24)
10x (20sec on, 90sec off). SR 30-34. Max effort each piece!	3x1500 w/4' off. Trying for consistent avg. split each piece.	2x18' w/3' rest SR 18-20
3x750m w/5' off. Add 5-10 sec on 1k goal split.	5x5' w/4'rest. Holding a strong/steady speed/rhythm. (Keep split & SR as constant as possible for entire piece)	4x11' w/4' rest. SR 3'@18, 2'@20, 1'@22, 2'@20, 3'@18
10' warm up. 10x300m w/3' off. STRETCH! DRINK WATER!	2x[5x1'@ steady state rate, 1'@ sprint rate w/2' off] w/10' rest	Aerobic Fitness 2x15' w/5' rest. SR 20-22
Start practice! 10x2' w/4' off	6x5' (3'@22, 1'@26, 1'@30) w/3' off.	10', 8', 6', 4' w/4' rest b/w pieces. Faster avg split each piece.
6x300m w/4' rest. Alternate start/sprint practice.	1000m w/4' off, 750m w/4' off, 500m. Faster each piece	2x15' w/5' rest. SR 20-22.
1x1000m erg challenge/test (Max effort test)	4x6' w/4' rest. SR 26-30.	Aerobic Fitness 2x2500m w/5' off. SR changes every 500m. SR: 24-26-28-26-24.
		4x12' w/3 (4'@22, 4'@24, 2'@26, 2'@28)

Step 3 (Recreational – Developmental): There is a progression to getting involved in adaptive rowing. Some people skip steps, where others utilize all of them to get a firm foundation of the sport and gradually increase confidence, knowledge and understanding of the sport. Follow this progression, although some steps might be skipped, if not appropriate, depending on the athletes' goals and ability:

- Initial discussion with coach
- Movement/ability analysis with coach
- Rowing machine/ergometer rowing
- Tank/barge, Dock Box/Oarman rowing
- Row in a double (2x) with a volunteer/coach
- Row in a single (1x) with a rope/leash
- Row in a single (1x) with a volunteer and/or coaching launch
- Row in boat (2x, 4+) with other adaptive athletes & coaching launch
- Row in national event category or racing configuration

Step 4 (Developmental): Once the athlete has tried the sport and is enjoying it, check his or her fitness level by occasionally by doing a 1,000-meter rowing ergometer test. This is a practice race piece that can measure and track improvement. Keep track of these. Doing this every month or so when starting out can help show significant improvements and encourage training.

Step 5 (Developmental): If the athlete is interested in possibly becoming a rowing U.S. Paralympic emerging athlete, review USRowing's sport classifications, results, standards and the annual sport performance plans here: [USRowing Team Testing](#), and the three-page rowing fact sheet section from the Paralympic Guide on pages 68-70 of the [US Paralympic Sport Guide](#).

Step 6 (Developmental): Athletes should try to get nationally classified within their first year of training to ensure they are training for, adjusting equipment and focusing on the correct race event for them. National classification can be done at local boat clubs and races. A list of classifiers in the country is available in the [US Classifiers List](#), or contact Judy Morrison to find out classification opportunities nationally (see contact list below.)

Step 7 (Developmental): USRowing tracks development primarily for athletes using the 1k erg test. In order to report scores, athletes should register for a [USRowing Championship Membership](#). Athletes who report times can be approached for training development camps and other opportunities for development under USRowing.

USRowing Adaptive Development & Elite Time Standards

Class	Gender	Time	Rating	
AS	Male	4:40:00		Development & VA Training Allowance Standard
AS	Male	4:20:00		Elite
AS	Female	5:50:00		Development & VA Training Allowance Standard
AS	Female	5:20:00		Elite
TA	Male	4:15:00		Development & VA Training Allowance Standard
TA	Male	3:50:00		Elite
TA	Female	4:50:00		Development & VA Training Allowance Standard
TA	Female	4:20:00		Elite
LTA	Male	3:35:00		Development & VA Training Allowance Standard
LTA	Male	3:20:00	28-34	Elite
LTA	Female	4:05:00		Development & VA Training Allowance Standard
LTA	Female	3:45:00	28-34	Elite

Step 8 (Developmental): Attend races. Races that USRowing particularly recommends, if limited in how many someone can attend, for emerging athletes to gain visibility include:

- C.R.A.S.H.-B. Sprints (February) and any regional indoor regatta (list can be found [here](#)). People who qualify based on times for C.R.A.S.H.-B.s have some expenses covered to attend the C.R.A.S.H.-B. Sprints. Winners from C.R.A.S.H.-B.s may have some expenses covered to attend national development camps.
- USRowing Trials (June). This is when the national boats are selected and where athletes get practice racing against the best in the country.
- [Bayada Regatta](#) (August). This is not an USRowing-owned event but is an event where athletes meet other athletes from all over the country. It can be useful for finding teammates with whom to train or race. Also, all adaptive/para-rowing staff at USRowing attend the event.
- Head of the Charles (October). This is a big exposure event for athletes racing.
- Local and other regattas provide excellent experience racing. Any opportunity to race is a good thing

Step 9 (Emerging): Athletes who meet development time standards may be eligible for additional benefits such as insurance, allowance, etc. Below is an example workout schedule

for someone on the development track. Work towards being able to complete these workouts and get on this type of training schedule/cycle.

Step 10 (Talent Pool): Once the development/elite time standard is met, the athlete should make sure he or she has a valid passport and has been internationally classified, or at least has all medical documentation prepared for classification. Medical paperwork is good for one year up until classification.

Step 11 (Talent Pool): As an athlete gets more involved in the sport, USRowing recommends researching ways to support his or her equipment and travel expenses with resources that are in place exactly for this purpose. If using a fixed seat, this tends to be a great starting point, then oars, then a boat.

Here are some additional national programs that help athletes fund equipment and travel expenses for their sport:

- [Challenged Athlete Fund](#), PA, NJ, MD, DE, DC, and NY
- [I'm Able Foundation](#), Youth (<18)
- [I Can Do Anything Scholarship](#), Veterans
- [ASG Program](#),
- GoFundMe/Kickstarter type fundraising sites
- [K2 adventure foundation](#)
- [Simon's Olympic Endowment](#) (USOC).

For most of these scholarship requests, athletes will need to write an essay and fill out an application with some basic information. They typically require two letters of recommendation from people with whom the athlete has interacted on more than just a personal level such as a coach, professor, psychologist, employer, etc. Most require details about how the money will be used, so there has to be a specific plan. Most are easy to work with after the fact if a plan changes slightly, and the funds have to be shifted around towards different expenses.

Step 12 (Talent Pool): Look into moving for training. All athletes end up traveling for a season, a year, or even more to train for international competition. When considering this, make sure to end up somewhere with a competitive program, quality coach, quality equipment and quality teammates. Some athletes move a month or so before a development/selection camp to try to increase their level prior to selection. Other athletes give themselves at least a year once they move to see how far they can advance. Moving doesn't necessarily mean moving to the Oklahoma City Training Center.

*NOTE: If an athlete has been on a national team or meets the elite standards, he or she may be able to receive housing in OKC, or help with housing in other locations pending approval.

Step 13 (National Team): When getting ready for national/international competition, it's important to understand what the athlete is responsible for versus what is provided.

- Athletes are typically responsible for providing their own goggles (LTA-VI), seats and straps (AS & TA), and oars. Boats sometimes will be provided, or athletes may be responsible for arranging a rental (particularly for overseas events).

- Athletes also are asked to pay their own way to competitions. Upon qualifying for the national team, athletes have to pay with a check or a credit card to cover expenses. Expense amounts partially depend on the location of the event. Events in the U.S. will be significantly less expensive than overseas. Expenses for overseas events that include airfare, boat rental, food and housing are typically around \$4,000 per athlete. If an athlete needs/wants a coach to attend, this is another \$3,000. Some boat clubs and grants can help cover these expenses, but the athlete has to put the money down as soon as he or she qualifies.

For the Paralympics, most clothes are provided by USRowing.

Step 14 (*Paralympic/Worlds Podium/Placement*): At the world championships, athletes who finish in the top four in the LTA4+, TA2x or AS1x get expenses reimbursed for the athlete (not coach expenses) by USRowing.

RESOURCES

- [US Para-Rowing Facebook Page](#)
- [US Adaptive Rowing Yahoo Group](#)
- [USRowing Adaptive & Para Rowing](#)
- Tom Darling (Para-Rowing Director): tdarling@usrowing.org
 - Emerging athletes interested in becoming part of the talent pool, development camps, etc.
 - National team athlete with questions about the FISA (international) classification process
- Deb Arenberg (Adaptive Program Development Specialist): deb@usrowing.org
 - Athletes looking for a local rowing program to join
 - Individuals or clubs trying to start an adaptive program at the local level
- Judy Morrison (FISA Classifier) jmorrisonpt@verizon.net
 - Questions about U.S. (national) classification such as nearby classifiers, where to get classified, needed paperwork, etc.
- Ryan Ortiz (USABA) rortiz@usaba.org
 - LTA-VI athletes looking for support or needing an advocate locally to help with training as an emerging athlete.
- Veteran Programming
 - Emerging athlete applying for VA Allowance
 - [VA Adaptive Sport Allowance](#)

Samples of Training Schedules

SUN (Optional)	MON	TUES (6:30pm @ WL)	WED	THURS	FRI (Optional)	SAT (12:30pm @ WL)
1/5/2014	1/6/2014	1/7/2014	1/8/2014	1/9/2014	1/10/2014	1/11/2014
		4x10' w/4' rest.		Off		10', 8', 6', 4' w/4' rest b/w pieces. Faster avg. split each piece.
1/12/2014	1/13/2014	1/14/2014	1/15/2014	1/16/2014	1/17/2014	1/18/2014
		2x18' w/3' rest LTA SR 18-20, AS/TA SR 30-34. Steady aerobic workout		Off	3x1500 w/5' off. Trying for consistent avg split each piece.	10' warm up. 10x1.5' w/3' rest. Try to hold 1k goal split.
1/19/2014	1/20/2014	1/21/2014	1/22/2014	1/23/2014	1/24/2014	1/25/2014
5x5' w/4'rest. Anaerobic Threshold work. Holding a strong/steady speed/rhythm		10x (20 sec on, 90 sec off) Fast Stroke Rate. (Start/Sprint practice) Max effort each piece!		Off	2x[5x1'@ steady state rate, 1'@ sprint rate w/2' off] w/10' rest	Off OR volunteer at Indoor Sprints to check out the races. Talk to Joy!
1/26/2014	1/27/2014	1/28/2014	1/29/2014	1/30/2014	1/31/2014	2/1/2014
4x11' w/4' rest. LTA SR: 3'@18, 2'@20, 1'@22, 2'@20, 3'@18 AS/TA SR: 3'@30, 2@34, 1@38, 2@34, 3@ 30		3x750m w/5' off. Add 5-10 sec on 1k goal split.		Off	10' warm up. 10x300m w/3' off. STRETCH! DRINK WATER!	1k Erg Test Race Practice (if not at practice, will do this at your next practice)
SUN (Optional)	MON	TUES (6:30pm @ WL)	WED	THURS	FRI (Optional)	SAT (12:30pm @ WL)
2/2/2014	2/3/2014	2/4/2014	2/5/2014	2/6/2014	2/7/2014	2/8/2014
Off		Aerobic Fitness 2x15' w/5' rest LTA SR 20-22, AS/TA SR 26-28. Steady aerobic workout		Off	3x1500m w/4' rest.	6x5' (3'@22/26, 1'@26/32, 1'@30/38) w/3' off.

2/9/2014	2/10/2014	2/11/2014	2/12/2014	2/13/2014	2/14/2014	2/15/2014
10', 8', 6', 4' w/4' rest b/w pieces. Faster avg split each piece.		Start practice! 10x2' w/4' off		Off	2x15' w/5' rest LTA SR 20-22, AS/TA SR 26-28. Steady aerobic workout	Sprint practice! 10x(20sec on, 90sec off). Max effort each piece!
2/16/2014	2/17/2014	2/18/2014	2/19/2014	2/20/2014	2/21/2014	2/22/2014
2x15' w/5' rest LTA SR 20- 22, AS/TA SR 26-28. Steady aerobic workout		Race Plan practice. 3x750m w/5' off. Add 5-10 sec on 1k goal split.		Off	6x5' (3'@22/26, 1'@26/32, 1'@30/38) w/3' off.	Aerobic Fitness 2x2500m w/5' off. SR changes every 500m. LTA: 24-26- 28-26-24. AS/TA: 28-30- 32-30-28
2/23/2014	2/24/2014	2/25/2014	2/26/2014	2/27/2014	2/28/2014	3/1/2014
4x10' w/3' rest		Focus on 3rd 250. 1000m w/5' off, 750m w/5' off, 500m. Faster each piece		Off	2x12' w/5' rest	North Allegheny Championship <i>*If not racing arrange with Joy when to do a 1k piece</i>

Sunday (Optional)	Monday	Tuesday (6:30pm @ WL)	Wednesday	Thursday	Friday (Optional)	Saturday (12:30pm @ WL)
3/9/2014	3/10/2014	3/11/2014	3/12/2014	3/13/2014	3/14/2014	3/15/2014
Off	5x12' w/8'rest for circuits (4'@22, 4'@24, 2'@26, 2'@28) Add 15-18 sec on 2k split.	3x1500m w/4' off. SR 24-30. + 6 sec on 2k goal split.	4x6' w/4' rest. SR 26-30. +5-9 sec on 2k split & Alternate with Tanks	10x(20sec on, 90sec off). SR 30-34. Max effort each piece! (Alternate Ergs/Weights)	Off	Workout on your own!
3/15/2010	3/16/2010	3/17/2010	3/18/2010	3/19/2010	3/20/2010	3/21/2010
Off	10' warm up 3 x 2.5k w/6' rest SPM 24-30. Cover Splits *Swimming at SHH	Sprint practice, 8x500m w/4' rest Alternate Covering Splits *Swimming at SHH	3x18' w/3' rest Every 3' change SR (22, 24, 26, 24, 22, 20) Cover Splits *Swimming at SHH	Start Practice! 8x2' w/4' rest. Cover Splits *Swimming at SHH	Off	Workout on your own!
3/22/2010	3/23/2010	3/24/2010	3/25/2010	3/26/2010	3/27/2010	3/28/2010
Off	4x1k w/8' rest. Race your plan! *Swimming at SHH	4x10' SR 24 w/2' rest. Handles taped. Add 15-18 sec on 2k Split. *Swimming at SHH	Team 2k Challenge!	3x18' w/3' rest Every 3' change SR (22, 24, 26, 24, 22, 20)	Off	Workout on your own!
Saturday 3/8/14	Saturday 3/15/14	Saturday 3/22/14	Saturday 3/29/14	Sunday 4/13/14		
4x6' w/4' rest.	10x(20sec on, 90sec off). SR 30-34. Max effort each piece!	2x15' w/5' rest Steady aerobic workout	3x1500m w/4' off.	4x6' w/4' rest.		
Saturday 4/19/14	Sunday 4/27/14	Saturday 5/3/14	Saturday 5/10/14	Sunday 5/18/14		
10', 8', 6', 4' w/4' rest b/w pieces. Faster avg split ea. Pc.	10x1.5' w/3' rest.	4x10' w/4' rest	Sprint practice, 6x300m w/4' rest Alternate	1k Team Challenge		

February 2014 Practice Schedule

Date: 1/30/2014

Micro	Mon	Tue	Wed	Thu	Fri	Sat	Sun
1 st Week Of January 27						February 2nd 20' Warm up 4x2k Rest 7' ZT+1" 30' Z2	February 2 nd OFF
2 nd Week Of February 3 rd	10' Warm up 30' Z2 w/ 10 strokes @ZR every 1k Rest 3' 30' Cross training Z3	15' Warm up 4x2k Z2 Start – Middle – Finish Rest 3' 20' Core and Stretching	Race Warm up 2000m Race Pace Rest for 5' then do 2x20 Z2 Cross Training, include stretching at the end	10' Warm up 25' Pyramid 30' Cross Training Z2 Rest 3'	15' Warm up 23' Castle Rest 4' 20' (1' ZT – 1' Z2 – 1' Z4 – 1' Z2) 20' Core or Stretching	20' Warm up 1250m (ZR+2) Rest 5' 1000m (ZR) Rest 4' 500m (ZR-2) Rest 2' 250m Max 20' Cool Down Z2	February 9 th OFF
3 rd Week Of February 10 th	10' Warm up 2x20' with 10 strokes at 2k pace each 4' otherwise Z2 Rest 3' 20' Z3	2x20 Z2 2x15 Z3 Cross Training Rest 2'	15' Warm up 1000m ZR; Rest 4' 500m ZR 20' Z2 Cool Down/Core If not doing CRASH-B Do 4x1k ZR Rest 4'	10' Warm up 20' (4' Z3; 1' Z1) 30' (4' Z2 1' Z5) Rest 2' 20' Z2	10' Warm up 4x15' Z2 Rest 3' Combination: Core, Rowing, Cardio Cross Training, Body circuit	Race warm up 2x2k Race preparation or 15' Warm up 3x3000m Z5 Rest 8' 30' Z2	February 16 th CRASH-B Sprints
4 th Week Of February 17 th	15' Warm up 6x 30"/90" 2x 20' Z2 Cross Training CRASH-B people OFF	10' Warm up 20' Z2 30' Z3 20' Z2 Cross training Rest 1'	15' Warm up 3x10' @ ZT Rest 7' 30' Z2	10' Warm up 25' Pyramid 23' Castle 20' Core	10' Warm up 3x16' (Z3/Z2/Z3/Z2 each 4') Rest 3' 20' Core or body circuit	15' Warm up 2k @ ZT; 1500m ZT-2 1k @ ZR; 750 @ ZR-2 500 Max Rest=Work 30' Z2 Cross Training	February 23 rd OFF
5 th Week Of February 24 th	15' Warm up 25' Pyramid Rest 3' 20' Z2 10' Stretching	30' Z2 25' Z3 20' Z2 Cross training Rest 1' 2	February 26 th 20' Warm up 5x 6' ZT Rest 6' 30' Z2 Cross Training	10' Warm up 25' Pyramid 30' Cross Training Z3 Rest 3'	15' Z2 Warm Up 45" ON /1'15" OFF x12 Full pressure @ 28/30 on erg – OTW 24 30'Z2		March 2 nd

Workout Zones for LAND WORKOUTS – Please adjust based on your PERSONAL MAXIMUM HEART RATE:

Z1 – Recovery 6k + 30"	HR: 100 to 120	@18
Z2 – 6k + 18"	HR: 120 to 140	@20
Z3 – 6k + 12"	HR: 140 to 150	@22
Z4 – 6k + 7"	HR: 150 to 170	@24
Z5 – 6k + 2"	HR: 170 to 180	@26
ZT – 6k Pace (2k + 6")	HR: 180 to 200	@28/30
ZR – 2k Race pace -	HR: 200 to Max	@32+

23' Castle

1' @18
2' @20
3' @22
4' @24
3' @22
4' @24
3' @22
2' @20
1' @18

25' Pyramid

4' – 3' – 2' – 1' – 2' – 1' – 2' – 1' – 2' – 3' – 4' = 25'
Z2 Z3 Z4 Z5 Z4 ZT Z2 ZR Z2 Z3 Z2

Glossary of Rowing Terms

Air Stroke	A rower error where the oar's blade is not completely in the water.
Alignment	The process of lining up each shell's bow ball prior to the start of a race so that they are level.
Anchor	An oarsman who slows a crew down. Like towing an anchor behind the boat.
Backsplash	The water thrown back toward bow by the oar's blade as it enters the water during the catch. A proper catch should throw a small amount of water.
Backstop	Refers to the bow ending of the track on which a rower's seat slides. The wheels of the seat should almost reach the backstop at the finish of each stroke.
Bisweptual	A sweep rower adept at rowing both the port and starboard sides.
Blade	The hatchet or spoon shaped end of the oar.
Body Angle	The amount of forward pivot of a rower's torso stemming from the hips during the recovery for a proper catch position.
Bow	The forward section of the boat. The first part of the boat to cross the finish line.
Bow Ball	The person in the seat closest to the bow, who crosses the finish line first.
Bow Number	A small rubber ball attached to the bow of each shell. Used as a safety device and for determining which crew crosses the finish line first during a close race.
Bow Pair	A card attached near the bow of each shell that identifies which lane the crew is assigned to.
Bowloader	The pair of sweep rowers in bow of the boat. This would be seats 1 and 2 in an eight or a four. The bow pair has the most effect on the set of the boat.
Bowside	Refers to a type of boat (usually a four) where the coxswain rides lying down beneath the bow decking. Most racing fours are bowloaders.
Bucket	The UK term for starboard despite the bow rower being on the starboard side or not.
Buoy	A way of rigging a shell so that two consecutive rowers row on the same side. Both double and triple buckets are possible. Also known as a "Continental" or "Italian" rigging.
Button	Colored flotation devices that mark lanes and other various areas of the racecourse. Also used for marking hazards.
Catch	A wide collar on the sleeve of the oar that keeps the oar from slipping through the oarlock. Also called a collar.
Check	The moment the blade enters the water and initiates the drive of each stroke.
CLAM	The reverse momentum resulting from the crews body weight moving toward stern during the recovery. Check is unavoidable but can be minimized through proper technique for optimal speed.
Collar	Short for Clip-on Load Adjusting Mechanism. A CLAM is a device that snaps on and off the sleeve of an oar to quickly adjust the inboard rig. Typically by 1cm per CLAM.
Cover	A wide collar on the sleeve of the oar that keeps the oar from slipping through the oarlock. Also called a button.
Coxbox	The distance between the 2-seat's puddle on one stroke and the stroke seat's puddle on the following stroke. The greater the distance, the more speed the crew has. Also called spacing.
Coxless	A coxswain's portable voice amplifier. Also has timing and stroke rating measurement capabilities.
Coxswain	A shell designed for rowing without a coxswain. Usually in a pair or a four.
Crab	Person (usually small) who steers the shell and coaches for the crew on the water.
Deck	Occurs from a blade work error where a rower is unable to properly remove their oar from the water. A crab can slow down or even stop the boat. In extreme cases a crab can eject the rower from the shell.
Digging	The part of the shell on top or the bow and stern that is covered with fiberglass cloth or a thin plastic.
Double (2x)	Rower error when the blade of the oar goes deeper in the water than it should, slowing the boat down.
	A sculling boat for two rowers.

Drive	Portion of the stroke that propels the boat through the water. The drive starts at the catch and ends with the release. The main power from the drive is generated by the rower's legs pushing off the footstretchers.
Eight (8+)	A sweep boat for eight rowers and a coxswain.
Engine Room	The rowers in the middle of a boat. For an eight, these would be seats 6, 5, 4, and 3. Generally the largest and most powerful rowers of the boat
Ergometer	Also called an 'erg'. The indoor rowing machine used for land based fitness training.
Feather	The act of rotating the oar at the finish so that the oar's blade is parallel to the water during the recovery. The opposite of the squared position.
Fin	The fin attached to the keel of the shell that helps stabilize and maintain a straight course. Also called a skeg.
Finish	The end of the drive when the rower removes the oar from the water and then feathers. Also called the release.
FISA	Short for Federation Internationale des Societes d'Aviron. International governing body for the sport of rowing.
Flutter	A race tactic during the body of the race, which is essentially a second start sequence to build up the speed of the shell. This is extremely taxing on the crew and is usually only used in desperation.
Foot Stretcher	The adjustable footplate with built in shoes, which allows the rower to adjust their position in the shell relative to the oarlock.
Four (4+ or 4-)	A sweep boat for four rowers. Can come with or without a coxswain.
Frontstop	Refers to the stern ending of the track a rower's seat slides on. The wheels of the seat should almost reach the frontstop at the catch of each stroke.
Gate	The bar across the oarlock that keeps the oar in place.
Grand Final	Finals at a regatta for places 1 through 6.
Gunwales	The top rails of the shell. Pronounced - 'gunnels'
Handle	Part of the oar that rowers hold on to during each stroke.
Hatchet	The modern and current oar blade that is rectangular or hatchet shaped.
Head Race	Type of race where crews start in a single file line and race for time. Longer than sprint races, head races range from 4k to 10k and are usually run on rivers during the fall season.
Heavyweight	The weight class in men's rowing for rowers over the lightweight restriction.
Hull	The body of the shell.
Inboard	Length of the oar measuring from the button to the handle.
Keel	The center line of the hull.
Launch	Motorboat used by rowing coaches and referees.
Lay Back	The amount of reverse pivot of a rower's torso stemming from the hips during the second half of the drive for a proper finish position.
Lightweight	A rower whose weight allows them to compete in lightweight events. For men, this is usually 155 lbs. Women, 130 lbs.
Loom	The part of the oar between the sleeve and the blade. Comprises the majority of the length of the oar. Also called the shaft.
Macon	The traditional u-shaped blade. Also called a tulip or spoon.
Megaphone	Device formally used by coxswains to communicate with the rowers. These were replaced by the invention of the coxbox. Megaphones are also used by coaches to communicate with the crew.
Missing Water	A rower error where the rower begins the leg drive before the catch has completed.
Novice	Any rower during their first season of competition.
Oar	Device used to drive the boat forward. An oar consists of several parts, in order from rower to water: Handle, shaft, sleeve, collar, shaft, and blade. The oar attaches to the boat at the oarlock.
Oarlock	The u-shaped lock at the end of the rigger that attaches the oar to the shell. The oarlock allows the rower to rotate the oar between the squared and feathered positions.
Open Weight	The weight class in women's rowing for rowers over the lightweight restriction.
Outboard	The length of the oar measuring from the bottom to the tip of the blade.
Pair (2+ or 2-)	A sweep boat for two rowers. Can come with or without a coxswain.
Petite Final	Finals at a regatta for places 7 through 12.

Piece	A practice term used to signify a specific interval during a workout. For example, "The third piece of the 5 by 5 minutes was our best."
Pitch	The angle between a squared blade and a line perpendicular to the water's surface. The standard pitch is around 4 degrees.
Pogies	A type of glove with holes on the ends, which allow the rower to row with bare hands on the handle.
Port	Left side of the boat, while facing forward, in the direction of the movement.
Power 10	A call by the coxswain for the crew to row the next 10 strokes at maximal effort in an attempt to increase boat speed and take water on the opponent.
Puddles	The disturbances in the water made by the blade during each stroke.
Quad (4x)	A sculling boat for four rowers.
Rating	The number of strokes per minute taken by a crew. During the body of the race a crew will maintain a rating in the mid to high 30's.
Ratio	The relationship between the time taken between the drive and recovery portions of the stroke. A good ratio will have about twice as much time taken during the recovery as the drive.
Recovery	The portion of the stroke after the rower releases the oar from the water and returns to the catch position.
Release	The end of the drive when the rower removes the oar from the water and then feathers. Also called the finish.
Repechage	A second chance heat at a regatta to ensure that all crews have two chances to advance. These races are for all crews that didn't qualify in during the heat. French word meaning 'to save' or 'second chance'.
Rib	The u-shaped structures in the boat that the hull and riggers attach to.
Rig	Term used to describe how the boat is set up.
Rigger	The triangular shaped metal device that is bolted onto the side of the boat and holds the oars.
Rudder	Name of person in charge of rigging and de-rigging shells.
Run	Attaches to the skeg and controlled by the coxswain to steer the boat by attached cables.
Rush	The distance the shell moves during one stroke. This can be seen by looking at the distance between the puddles made by the same oar
Sculler	A rower error where the rower moves toward the stern during the recovery before the rest of the crew. This increases the amount of check during each stroke.
Sculling	A rower who rows with two oars. One in each hand.
Seat	One of the two disciplines of rowing. In sculling each rower uses two oars (one in each hand) to move the boat.
Seat Number	Molded seat mounted on wheels that the rower sits on. The seats rolls on tracks, which allow each rower to generate power with their legs.
Seat Race	Refers to the rower's position in the boat counting up from bow to stern. In an eight these are counted as the bow seat being 1, then 2, 3, 4, 5, 6, 7, and finally 8 in the stern. 8 seat is also referred to as 'stroke' seat.
Set	A coach's tool for comparing two rowers. Two boats race against each other once. One rower from each boat switches positions and the two boats race again. Relative performance in the two races is used to compare the abilities of the two rowers.
Settle	Refers to the balance of the boat. An unset boat will lean to either port or starboard.
Shaft	Refers to a down shift in stroke rate after the start of a sprint race. Crews use the settle to get to their base stroke rating they will row the body of the race.
Shell	The part of the oar between the sleeve and the blade. Comprises the majority of the length of the oar. Also called the loom.
Shooting Slide	Another name for the boat and is used interchangeably.
Single (1x)	A rower error when the rower's legs drive the seat toward bow without bringing the load of the water with them through the torso and shoulders.
Skeg	A sculling boat for one rower.
	The fin attached to the keel of the shell that helps stabilize and maintain a straight course. Also called a fin.

Skying	A rower error where the rower drops their hands just prior to the catch. This causes the blade to move higher off the water and will disrupt the set of the shell.
Sleeve	A thin piece of plastic around the oar that keeps the oarlock from wearing out the shaft of the oar.
Slides	Rails that the rower's rolling seat roll on. Also called tracks.
Slide Jump	A rower error where a rower leaves their seat and knocks the seat off the tracks.
Sling	Portable folding boat holders. Two are required to hold a boat and are seen frequently at regattas.
Smoothie	A more recent oar blade design with a smooth face.
Spacing	The distance between the 2-seat's puddle on one stroke and the stroke seat's puddle on the following stroke. The greater the distance, the more speed the crew has. Also called cover.
Speed Coach	A keel mounted impeller that transmits speed to the coxswain or coach.
Split	The amount of time it would take a rower or crew to complete 500 meters at their current pace. This can be applied to both a crew on the water or a person on an erg.
Spoon	The traditional u-shaped blade. Also called a macon or tulip.
Sprint	The last portion of a race. Usually the last 250 meters of the race are run at a maximum stroke rate in an attempt to get to the finish line first.
Sprint Race	Type of race where crews race side by side in lanes over 2000 meters. In the US, this is the standard race and the season is the spring and summer.
Square	The act of rotating the oar prior to the catch so that the blade is perpendicular to the water. The opposite of the feathered position.
Stakeboat	The small anchored boat that is used to hold the shells in place at the starting line.
Starboard	Right side of the boat, while facing forward, in the direction of the movement.
Starboard Rigged	A boat rigged so that the stroke seat is a starboard rower.
Start	The beginning of the race. Crews will have a specified starting sequence of strokes to get the shell up to speed as quickly as possible. Stroke ratings during a start sequence range from the low 40s to the high 50s.
Stern	The rear of the boat; the direction the rowers are facing.
Stern Pair	The pair of sweep rowers in the stern of the boat. This would be seats 7 and 8 in an eight or seats 3 and 4 in a four. The stern pair is responsible for setting the rating and rhythm for the rest of the crew.
Straight	A coxless sweep shell. Only for a pair or a four. Referred to as a 'straight four.'
Stroke	One complete cycle of the catch, drive, release, and recovery.
Stroke Rating	The number of strokes per minute taken by a crew. During the body of the race a crew will maintain a rating in the mid to high 30's.
Strokeside	The UK term for port despite the stroke rower being on the port side or not.
Sugaring	Rowing which looks good from a distance but in reality the rower is not putting any work down on the oar.
Swamped	Swamping occurs when a shell takes on too much water from rough conditions and is no longer rowable.
Sweep	One of the two disciplines of rowing. In sweep rowing, each rower uses one oar and is paired with another rower of the opposite side. Sweep boats are called pairs (2 rowers), fours (4 rowers), and eights (8 rowers). All three classes can include a coxswain. Pairs and fours can come without a coxswain.
Swing	The feeling in the boat when all rowers are driving and finishing their strokes together.
Tanks	An indoor training facility that consists of two rows of rowing seats between two tanks of water. Allows rowers to feel their strokes in the water in a stable and controlled environment. Used heavily when teaching novice rowers.
Third Final	Finals at a regatta for places 13 through 18. Commonly referred to as the "truck" final since your crew would be loading your boat on the truck during the grand finals.
Toe	A steering device for a coxless boat. A rower can steer the rudder by changing the direction their foot points.
Tracks	Rails that the rowers rolling seat roll on. Also called slides.

Tulip	The traditional u-shaped blade. Also called a macon or spoon.
Understroke	Rowing at a lower and more efficient rating than your opponent.
Wash	Refers to the wake given off of a shell.
Washing Out	A rower error when an oar comes out of the water during the drive and creates surface wash. This results in a reduction in speed and can disrupt the set of the boat.
'Way Enough' or 'Weigh Enough'	'A very common call by a coxswain to tell the rowers to stop whatever they are doing.

USRowing List of Suppliers

Boat Manufacturers

[Alden Ocean Shells](#)

[BBG](#)

[Durham Boat Company](#)

[Echo Rowing](#)

[Edon Recreational Shells](#)

[Elite Rowing, Inc.](#)

[Empacher](#)

[Filippi](#)

[Fluidesign](#)

[Hudson Boat Works](#)

[Kaschper Racing Shells](#)

[Little River Marine](#)

[Little Sculling Boat Company](#)

[Maas Rowing Shells](#)

[Nautical Architecture](#)

[Peinert Boat Works](#)

[Pocock Racing Shells](#)

[Resolute Racing Shells](#)

[Ron Rantilla Rowing Systems](#)

[Swift Racing](#)

[Sykes Racing](#)

[Van Dusen Racing Shells](#)

[Vespoli USA](#)

[WinTech Racing](#)

Boat Repair

[Finish Line Shell Repair](#)

[Rowing Repair Center](#)

[Klinger Engineering](#)

[Shell Repair USA](#)

Clothing/Gear

[Boathouse Sports](#)

[H2row -- Rowing Shoes](#)

[JL Racing](#)

[Nike Rowing](#)
[Patagonia](#)
[Regatta Northwest](#)
[Regatta Sport](#)
[Row West Clothing](#)
[The Rowing Store](#)
[Sew Sporty](#)

Ergometers

[Concept 2](#)
[WaterRower / WaterCoach](#)
[Shox-Box](#)
[SimulatOar](#)

Miscellaneous Products

[Accudock](#)
[Adirondack Rowing](#) – A diverse selection of rowing products.
[Allegheny Trailers](#) – Trailers
[Art of Rowing](#)
[Burnham Boat Slings](#) – Slings
[Buffalo Rowing](#) – Rigging Tools
[Connect-A-Dock](#) – Docks
[Craftsbury Sculling Center](#) – Sculling Camps
[The Dock Doctors](#) – Commercial and Residential Docks
[Durham Boat Company, Inc.](#) – Dreher Oars, Boats and More
[EZ Dock](#) – Docks
[Leonard Insurance Group](#) – Shell Insurance
[MaxRigging](#) – Rigging Information
[Mercia Marine Underwriting, Ltd.](#) – Shell Insurance
[Muser, Inc.](#) – Backstays
[Nielsen-Kellerman](#) – Rowing Electronics
[NIKE Rowing Camps](#) – Rowing Camps
[No Limits Rowing](#) – Sculling Camps
[OARS Team Building Program](#)
[RegattaCentral](#) – Regatta Management Web Site
[Regatta Sport](#) – Clothing, as well as the North American Distributor for FISA Products such as World Championship Videos.
[Roehrs & Company, Inc.](#) – Official Insurance supplier of USRowing.
[Rowbike](#) – The Rowbike is powered by the same slide seat rowing motion as a scull, giving the training experience of an indoor rowing machine.
[Rower's Almanac](#) – Rowing Directory
[The Rowers' Code](#) – Teambuilding Workshops
[Rowing Magazine](#) – Monthly Rowing Magazine
[The Rowing Repair Center](#)
[Rubini Jewelers](#) – Rowing Jewelry
[Skwoosh](#) – Performance Seat Cushions and Pads

Sparhawk Model Oars – Model Oars
Sparks Consulting
SportGraphics – Rowing Photography
Stillwater Designs – Launches and Tanks
Thiemann Equipment – Slings and Trailers
UK Sports Products Ltd – Inflatable Ice Baths
Whirling Girl Rowing Jewelry

Oars

Concept 2
Croker Oars
Dreher Oars
WinTech Racing