

## In this issue

Editors' Notes .....	2
The Cahill Electrical Typewriters.....	3
Demystifying the McCool .....	9
Back to Basics: A Platen Primer.....	13
Ephemera: The Last Maskelynes .....	14
Tale of the Century.....	21
His Father's Fault? .....	23
The Oliver Woodstock.....	24
An Esperanto Typewriter? .....	26
Richard N. Current .....	27
Brother JP-3 .....	28
Letters and More.....	30



# ETCetera

Journal of the  
Early Typewriter  
Collectors' Association

No. 100 -- December 2012



# ETCetera

Journal of the  
Early Typewriter  
Collectors' Association

December 2012

No. 100

Editor:

Richard Polt  
4745 Winton Rd.  
Cincinnati, OH 45232  
513-591-1226  
polt@xavier.edu

Secretary-Treasurer & Mailer:  
Herman Price

German translation:  
Norbert Schwarz

Spanish translation:  
Fransu Marín

©2012 ETCA. Published quarterly.  
Calendar year subscription: \$35,  
North America; \$40 elsewhere.  
Checks payable to Herman J. Price,  
195 Greenbag Rd., Morgantown, WV  
26501, USA; or use paypal.com to  
pay etcetera.payments@gmail.com.  
ISSN 1062-9645  
tinyurl.com/etctype

## On Our Cover

*Christopher Latham Sholes*

by Frank Grau

[www.frankgrau.com](http://www.frankgrau.com)

This typewriter works really well except for one key. Sometimes organizations work like this typewriter. You can tell yourself, "the Early Typewriter Collectors Association can get by without any extra effort on my part....after all....I'm only one person...I won't make or break this organization." But one person will make a difference in terms of the success of this organization just like one key does make a difference in the printed output of a typewriter. So....tell yourself, "I am a key person in this new organization and my involvement is really needed."

—Contributed by Ed Reis to  
ETCetera no. 1, October 1987

## Editors' Notes



Darryl Rehr was the inaugural editor of *ETCetera* and set a very high standard for 13 years, inspiring me and many other typewriter collectors. Chuck Dilts and Rich Cincotta served as innovative and enthusiastic editors for the next five years. I have now had the privilege of editing this magazine for seven years and of bringing it to its hundredth issue. It has been a great experience, but I am now ready to pass the baton so that I can have more time for other aspects of my life and of this hobby.

I would not consider turning the magazine over to anyone who was unable to continue its tradition at a high level. But Alan Seaver has the love of typewriters, the intelligence, the knowledge, and the sense of design to do the job very well. I am glad to report that Alan is willing to serve as *ETCetera's* next editor. He will begin with the March 2013 issue. I will help with the transition and will contribute to the magazine as needed; Peter Weil and Robert Messenger will still write their excellent columns, and Herman Price will continue his invaluable service. In 2013 you can look forward to stories about rarities like the Shimer and the Phönix as well as more common but still delightful typewriters.

If you haven't yet, I urge you to visit Alan's website, [machinesoflovinggrace.com](http://machinesoflovinggrace.com). It spotlights his photography, his research, and his organization. I am looking forward to enjoying everything Alan will achieve at the helm of *ETCetera*.

—Richard Polt



It is with a mixture of honor, pride, and trepidation that I assume the helm of this distinguished publication. *ETCetera* is far and wide the finest publication in its field, thanks in no small part to the efforts and dedication of my predecessors. With Richard's exit, he leaves the newsletter at the absolute pinnacle of its existence. That's a hard act to follow.

My aim in the short term is to act as a steward for what Richard, Chuck, Rich, and Darryl have created, to ensure that *ETCetera* does not slip from the level of quality and excellence you've come to expect. With a little luck, we will make it even better.

I'd like to hear from you. What changes would you like to see? Any new features that you would like to add? Retired features that you would like to return? I'm personally excited about further exploring the growing world of the so-called typosphere, the folks who are equally comfortable at a typewriter keyboard and at a computer keyboard, and bringing the two together. Send your thoughts to [editor@etconline.org](mailto:editor@etconline.org). That reminds me: by the time *ETCetera* 101 hits your mailboxes, there should be a brand-new Web presence for you to visit!

But the editor's is ultimately only a superficial role. The true heart of *ETCetera* is its contributors, you guys. I am confident that there is no shortage of great material out there, of discoveries yet to be made and stories to be told.

Keep those keys moving!

—Alan Seaver

# The Cahill Electrical Typewriters

by Bert Kerschbaumer



The appearance of an invention from the mists of history, once believed to be lost, is always an exciting event—especially when, as in our case, it’s a typewriter. Not just that, but a historically significant invention, a milestone in the development of the electric typewriter—the Cahill Universal Electric No. 2! In 2005, a photograph<sup>1</sup> was the occasion for an article on the Cahill Electric that ended with the following sentence: “After all, only in 1908 someone offered to trade a Cahill for a 12 gauge shotgun or a good photo camera in Washington, D.C. That machine may show up on eBay at any time.”<sup>2</sup> How true!

## *The Person*

Dr. Thaddeus Cahill was the inventor who gave this typewriter its name. His better-known creation is the “Telharmonium,”<sup>3</sup> an ancestor of the synthesizer that weighed 200 tons, but in the world of office technology his name is synonymous with the first electric typewriter to be put on the market commercially. Thaddeus Cahill was born the fourth of eight children on June 18, 1867 in Mount Zion, Iowa, and grew up in Oberlin, Ohio. After the early death of his mother and the retirement due to ill health of his father Timothy, who could no longer practice his profession of physician, Thaddeus and his sister Mary, in contrast to their siblings who attended public school, were home schooled by their father, for he soon recognized their unusual talent and encouraged it. Thaddeus gained his first professional experience when he was 14, as a stenographer for a court in Ohio, and here he made his first acquaintance not only with jurisprudence but also with the typewriter and its defects. His second passion was

music—neither active performance as a musician nor passive listening, but the enthusiastic invention of new instruments and acoustical apparatus; this was already evident in 1885, when he was only 18 years old, in his first patent application (US 345028), which was granted the following year. At the age of 22 (1889), Cahill became secretary to Congressman Amos J. Cummings and moved to Washington. There he served in various secretarial positions in Congress, and in the evenings he studied law at Columbia University (today George Washington University). After concluding his studies he received an offer to join a well-known Washington law office, but passed it up in order to remain true to his passion as an inventor.

## *Early developments and patents*

In 1892, Cahill constructed a prototype of an electric typewriter, and in the next year he received a patent for a mechanical typewriter with a piano-style keyboard (US 502700). His ideas for two keys striking simultaneously and for a typewriter with a separate keyboard for each hand were patented in 1895 (US 531904, US 541222). In 1896, he patented an electric typewriter with two separate piano-style keyboards. The typebars, arranged in a circle, were driven by a battery or dynamo (US 566442). A photograph (*next page*) documents one of the first electric typewriters built by Cahill, known as the “Cahill one-hand electric typewriter number 1 of 1896,” with a piano-style keyboard.<sup>4</sup> The understroke mechanism with the typebars in a circle remained with little change in the Model 2. For the Model 2, Cahill patented both a version with a conventional QWERTY keyboard



the manufacture of their typewriters.”<sup>6</sup> Unusually, the company kept Washington, D.C. as its place of production, despite the lack of skilled workers and machines there. It may be that the reason was the good connections to the government and politicians through shareholder and Congressman Amos J. Cummings. In June 1900, the factory grew: “The Cahill Writing Machine Manufacturing Company, which has for years employed a large force of workmen in perfecting its electrical typewriters, is increasing its plant. It has just leased another floor of the Barber & Ross building [4th and 5th floor (Washington, DC, NW, G Street)], which it is fitting up, and is importing additional machinery and workmen to advance the manufacture of its machines.”<sup>7</sup> Since we have found no marketing activities in the years up to 1900, we can infer that there were persistent problems in the function of the electric machine (“perfecting”) as well as with the production process (“advance the manufacture”).

and a version with a piano-style keyboard. As an alternative to electric power, the same patent of July 1900 (Austria 13354B) also described a pneumatic power source. Many further patents for the electric typewriters were issued in America and Europe until 1916 (e.g. US 1197103).

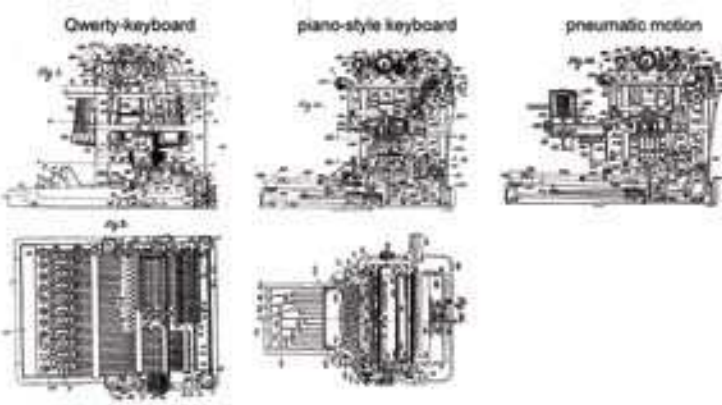

*Cahill Electric: History of the company*

On June 18, 1897, the Cahill Writing Machine Manufacturing Company, with a capital of two million dollars, was added to the commercial register of Trenton, New Jersey.<sup>5</sup> The shareholders were Amos J. Cummings, E.H. Jackson, and Thaddeus Cahill’s brothers George F. Cahill und Arthur Cahill. The goal of the company was to produce typewriters following Thaddeus’ patents. In November 1899 it was reported that “The Cahill Writing-Machine Manufacturing Company, who control the electrical typewriter, are importing machinery from the North to enlarge their plant. They have also brought in a number of skilled mechanics and tool makers from Connecticut, and are hurrying



*Amos J. Cummings*

from Connecticut, and are hurrying

In Fall 1900, a sales brochure<sup>8</sup> for the “Cahill Electrical Typewriter” appeared, describing the advantages of the “Universal Electric No. 2” model. The machine’s motto was: “Electricity Does the Work and Saves the Nerves and Time of the Operator.” This brochure contains the first illustration of the Cahill Universal Electric No. 2, which already in 1901 was used by Dupont and Canet<sup>9</sup> and later in the standard reference works by Mares<sup>10</sup> and Martin.<sup>11</sup> In September 1900 an ad<sup>12</sup> appeared seeking a sales location in Washington; a place was found, and by December 1900 at the latest, the company had a sales office at 1311 F Street. In November 1900, the first description of the Cahill Electric Typewriter appeared in the journal *Electricity*.<sup>13</sup>



In December 1900, at the yearly shareholders’ meeting in New Jersey, the name of the company was changed to “Cahill Electric Typewriter Company,” and it was decided to increase the capital



*Barber & Ross Building, Washington, D.C.*

from \$710,000 to \$1,250,000<sup>14</sup> (evidently the two million dollars of capital mentioned at the founding of the enterprise had not materialized). We now also find increased marketing efforts in the local press, explicitly trying to find investors for the company; sales of the typewriter are a secondary matter. The following lines in the ad are noteworthy: "A sale of 10,000 electrical typewriters a year, with a profit of \$50 on each machine, would enable the company to pay 40 per cent dividend on its stock."<sup>15</sup> To support this very optimistic estimate, a further advertisement refers to the company's quasi-monopoly and its patent protection: Hon. Ellis Spear, late commissioner of patents and now one of the company's directors, is quoted as saying, "In a word, the Cahill Company by hundreds of claims in its numerous patents are believed to have covered all commercially practicable types of motor-operated typewriters, whether electric or pneumatic—all in which a single motor device serves to actuate all the type-bars of a machine or a plurality of them, each as required."<sup>16</sup> Further ads feature testimonials from users who have already had months of experience using electric Cahills, and naturally offer very positive recommendations. All ads use always use the plural "typewriters," since both the QWERTY ("Universal") machine and the piano-style ("Simplex") machine were marketed in parallel. The customers providing testimonials come primarily from government institutions and offices, which can be attributed to the location in Washington, D.C. and/or to the contacts of Congressman Amos J. Cummings, who is now a Director. Then, at the end of the year, there appears the first and last advertisement that is only for the Cahill machines, and is *not* looking for capital.<sup>17</sup>



ary 1901 a notice appears that if the necessary capital is raised, the company will soon be listed on the local stock exchange.<sup>21</sup> The Cahill mostly seems to appear in press coverage of the stock market, but technical electrical journals also print stories about it: a thorough, illustrated description of the machine appears in *Western Electrician* in February 1901<sup>22</sup> and in *Electrical Engineer* in May 1901.<sup>23</sup> In its first issues for 1901, *Schreibmaschinen-Zeitung* runs several short pieces about the Cahill, and in April 1901 it says, "This machine invented by American Thaddeus Cahill was put on the market at the start of the current year, so it is the first practically useful electric typewriter."<sup>24</sup>

The machine was able to register its first great success at the Pan-American Exposition in Buffalo, where it was exhibited in the Government Building, at government expense, as an example of the positive effects of the patent system: "The most popular of the U.S. government exhibits was the Patent Office section, where visitors could see x-rays revealing their skeletons ... pictures sent by telegraph, electric typewriters...."<sup>25</sup> In contrast to other machines on display, the Cahill was freely accessible, and every interested visitor could write on it himself and convince himself of the quality of the machine.<sup>26</sup> At this time some sales to public authorities at \$112.50 are also documented (which would mean a 10% discount for the government from the list price of \$125).<sup>27</sup>

On May 23, 1901, the Cahill Typewriter Company returned to the headlines because its mechanics went on strike, as they did everywhere in the country, for a nine-hour workday.<sup>28</sup> This conflict dragged on for several months,<sup>29</sup> and only on August 1, after work stoppages, were wages paid again.<sup>30</sup>

A November 1901 story tells us:

The capitalistic end of the enterprise has recently sought to gain control of the company. As the Messrs. Cahill had for some time desired to be free from the active business management of the company, in order to devote their time to other matters, propositions were soon made looking to their transferring control of the stock to the capitalists of the company. The result of these negotiations was a con-

## ELECTRICAL TYPEWRITERS.

In the Cahill Electrical Typewriters the typebars, motor mechanism, and ribbon mechanism are operated by a single electro-magnet, and so the machines

- Have an exceedingly light and shallow depression or touch;
- Use a legato or running touch, instead of the old staccato;
- Make the space simultaneously with last letter, saving 20%!
- Make carbon copies automatically, touch remaining unchanged;
- Produce a perfect uniformity and clearness of impression;
- Are more durable and substantial, as weight does not increase touch.

The use of electricity to impel the mechanism of a typewriter removes the physical and nervous strain of writing, increases the speed and output of the operator, and produces a uniformity and clearness of impression unattainable on non-electric machines.

### The Cahill Electric Typewriter Company,

1311 F Street.

"Electricity does the work."

Obviously not enough new capital could be found for the new company on the market, so the quest to attract new capital was linked to the search for a new place of production. The *Schreibmaschinen-Zeitung* already reports in November 1900 that negotiations are underway to erect a factory for the Cahill electric typewriter in Rochester.<sup>18</sup> More negotiations were started with the cities of Worcester, Mass. and Richmond, Va. to start factories there if enough capital could be brought to those locations.<sup>19</sup> The company is said to have about 80-100 employees.<sup>20</sup> In Febru-

tract, ratified by the stockholders yesterday in Jersey City, by which the company has sold to Mr. Cahill, representing the interests of his brothers and sisters, all its rights in its simplex, duplex and pianokeyboard typewriters, for which he paid the company 8,750 shares of stock. The value of this stock runs into many thousands of dollars, and it is believed to be one of the largest transactions in the stock of a local company made for some time. This places the control of the company, which will manufacture and place upon the market electrical universal keyboard machines, in the hands of a combination of capitalists, and also returns to the treasury of the company a large amount of stock. What will be done with the machines obtained by the Cahill interest is not yet made public. They will, however, soon sever their active connection with the company to devote their attention to other scientific work.<sup>31</sup>

With this announcement, production practically comes to an end, and from this point forward there are only very infrequent references to the Cahill Typewriter Company. Thaddeus Cahill left Washington by the beginning of 1902 at the latest, in order to devote himself in full to the development of the Telharmonium. But the company did survive, and in 1904 it was still receiving contracts to repair its electric typewriters,<sup>32</sup> although one cannot say whether new machines were being produced or how many people the company employed. It appeared in the business register up to 1906 with a capital of at least \$875,000, and paid the corresponding taxes.<sup>33</sup> *Schreibmaschinen-Zeitung* announced in summer 1905: "The insolvency of the Cahill Typewriter Co. was announced on April 7 at the request of inventor and stockholder Thaddeus Cahill. During the eight-year existence of the company only 40 machines were manufactured, while \$157,000 were spent on expenses. The inventor requires \$6000 for the patent costs but owns 5770 shares at \$50."<sup>34</sup> On April 8, 1905, Thaddeus Cahill sued the Cahill Typewriter Company in order to secure the rights to the electric typewriter patents that he had

bought from the company in 1901.<sup>35</sup> The company collapsed in 1907: "New Jersey Charter void 1907. For nonpayment of taxes."<sup>36</sup>

Cahill's second great invention, the Telharmonium, was also a technical success but not a commercial one, and with the triumph of radio it became obsolete. Thaddeus Cahill died at the age of 66 on April 12, 1934. His brother, Arthur T. Cahill, filed his last patent in connection with a typewriter (US 2354196, "Typewriter Machine, Typesetting Machine and Other Keyboard Instruments").

### Technical details

The workings of the Cahill Universal Electric No.2 were described in 1901 in the journal *Western Electrician*<sup>37</sup> as follows.

The very simple electrical device, consisting of a motor frame, an electromagnet and a rheostat, is placed below the type basket. The motor frame has a flat bar on the front side, and is held down by a spring, which is immediately below the magnet. There is but one electric circuit, one contact point and one magnet. By depressing a key a pendant is thrown over the motor frame and the circuit is closed. Instantly the magnet pulls up the motor frame and shoves up the pendant. The pendant actuates a lever which pulls down a wire, throwing the type bar upward and making the imprint. The circuit is automatically broken. The type bar is free to return independently of the key. In the company's salesroom and the government departments and business offices, where the machines are in use, a plug has been inserted in the electric-light socket, and current is taken from the local lighting circuits. A flexible twin cable leads to the rear of the machine, as shown in the picture [see illustration, p. 5], and is connected by binding posts. In the fuse block for the electric light a quarter-ampere fuse is inserted. The machines can also be operated

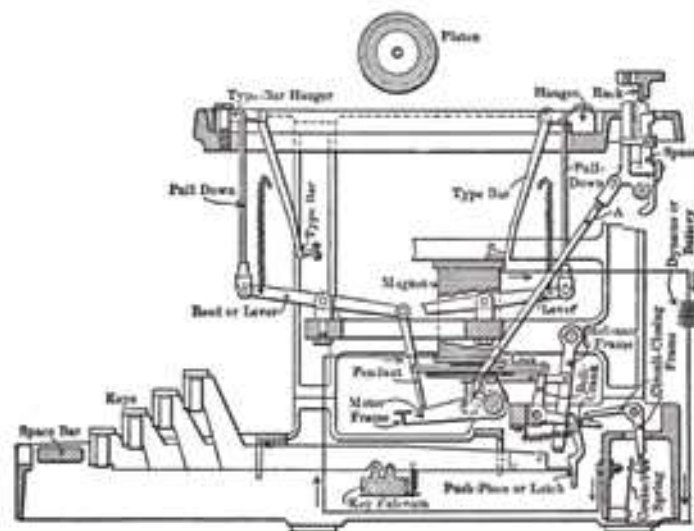

by using five cells of primary battery or two small cells of storage battery. There is very little current consumed, as was shown by a meter measuring the current used by one machine in constant service for one month. The bill was 12 cents, on a basis of 15 cents a kilowatt-hour for current.

The strength of the electromagnet is controlled by a rheostat, the handle of which is just back of the magnet, so that the force of the impression is regulated at the will of the operator, according to the kind of work being done. For ordinary work a weak current is used, but for taking carbon copies the strength of the current is increased, so that the type bar delivers a stronger blow. More than 20 distinct carbon copies have been made at one time, of a quality not yet attained by any non-electrical typewriter. Other advantages of the electrically operated typewriter are thus stated: Only a light touch is necessary, a four-ounce touch being sufficient to operate the key; the depression of the key is only about one-third that of non-electrical machines; a running or overlapping touch is easily acquired by the operator and several keys can be depressed in succession without releasing the preceding key; a saving of one action on each word is made by making the space simultaneously with the last letter of the word; the printing is uniform as to clearness, as each type bar is impelled by the same magnet in the same manner and with identically the same amount of force. The machines are said to be substantially built, and the moving parts made heavier, as they are impelled by an external force of greater power than the light touch of the operator's fingers.



The machine in my possession, serial number 4, matches this description with the exception that the built-in rheostat does not have six different positions for current voltage but functions only as an on/off switch. The spacebar mechanism is remarkable: it can be depressed at the same time as the last letter of a word. The striking of the type is then mechanically displaced by one space,

and the escapement advances by two spaces. In order to make a single space possible, there is a special "SPACE KEY" on the keyboard that activates a typebar without any type. The function can be switched to that of a "normal" spacebar by turning a knob on the left rear that stops the double spacing.



On the base is a plaque that tells us that the machine was given to an IBM employee in 1976 as a gift upon her retirement. At this time the machine must have been disassembled, thoroughly cleaned, and then put back together in a way that looked right, but was technically very imprecise. In the course of his successful restoration, Franz Pehmer was able to return all pieces to their original positions by consulting patents, photographs, and his own great wealth of experience. A specialized company replaced the damaged exterior wiring on the electromagnetic coils. Mechanically, the machine was ready to work—and after installing the electromagnets and their electric cords, using the correct voltage, it is possible to write on the machine.



The voltage needed is surprisingly high by today's standards. When it is controlled by a DC power supply with adjustable voltage, the coil draws 32 volts and 1.3 amperes; but for rapid writing, one needs at least 37-40 volts DC. But because of the diameter of the wiring of the coil, an amperage of 0.3 amperes and a correspondingly higher voltage would be ideal. The ribbon advances not only mechanically but also by means of an electrical impulse. Shift, paper advance, and carriage return are by hand.

Writing in 1901, Dupont compares the Cahill Universal Electric No. 2 to the Germania Electric; Mares sees parallels to

the Remington 2. Both writers, in all probability, saw only the illustration in the instruction manual and drew their conclusions from it. Since at 55 lbs. (25 kg) the Cahill tips the scales at almost twice the weight of the Remington and is considerably more massively built, the differences are immediately evident. The essential pieces, such as the entire lever system and the escapement, are unique.



With the only known example of a Cahill electric typewriter, which is still capable of writing, the genius of inventor Dr. Thaddeus Cahill can now be abundantly proved, and another piece of the puzzle can be added to the great picture of the history of the mechanization of writing! 🖨️



## Notes

1. My gratitude goes to the owner of the photograph, Peter Weil, once again, for his friendly support in the preparation of this article and for taking the machine into his safe harbor. Even so, without the expert ability of a Franz Pehmer, it would have been impossible to restore this machine and bring it back into writing condition. Thanks to Richard Polt for translating this article into English.
2. Paul Robert, "A Case for the Cahill," *The Virtual Typewriter Journal*, vol. 2, no. 3, 2005.
3. Reynold Weidenaar, *Magic Music from the Telharmonium* (Metuchen, N.J.: Scarecrow Press, 1995).
4. Photograph in possession of Margaret Eleanor Cahill Schwartz, purchased by Reynold Weidenaar.
5. *The Evening Times*, Washington, D.C., June 19, 1897.
6. *Electricity: A Popular Electrical Journal*, vol. XVII, no. 19, New York, Nov. 1899.
7. *The Washington Post*, Washington, D.C., June 25, 1900.
8. Trade catalog from Cahill Writing-Machine Mfg. Co., Washington, D.C., 1900 (with thanks to Trina Brown of the Smithsonian Institution Libraries, Washington, D.C.).
9. H. Dupont and L. F. Canet, *Les machines à écrire: Historique, avantages, descriptions et traité complet de dactylographie ou art d'écrire à la machine* (Paris: Édition de la Plume sténographique de France, 1901).
10. G. C. Mares, *The History of the Typewriter: Being an Illustrated Account of the Origin, Rise and Development of the Writing Machine* (London: G. Pitman, 1909).
11. Ernst Martin, *Die Schreibmaschine und ihre Entwicklungsgeschichte* (Aachen, Germany: Peter Basten, 1949).
12. *The Times*, Washington, D.C., September 2, 1900.
13. *Electricity: A Popular Electrical Journal*, vol. XIX, No. 21, New York, Nov. 1900.
14. *Electricity: A Popular Electrical Journal*, vol. XIX, No. 22, New York, Dec. 1900.
15. *The Times*, Washington, D.C., December 11, 1900.
16. *The Times*, Washington, D.C., December 17, 1900.
17. *The Times*, Washington, D.C., December 30, 1900.
18. Otto Burghagen, *Schreibmaschinen-Zeitung*, Hamburg, no. 29, November 15, 1900.
19. *Annual Report of the Worcester Board of Trade*, Worcester, Mass., 1901.
20. *The Times*, Richmond, Va., March 24, 1901.
21. *The Times*, Washington, D.C., February 11, 1901.
22. *Western Electrician* (Chicago: Electrician Pub. Co.), February 2, 1901.
23. *The Electrical World and Engineer* (New York: Electrical World and Engineer), Vol. XXXVII, No. 19, May 11, 1901.
24. Otto Burghagen, *Schreibmaschinen-Zeitung*, Hamburg, no. 34, April 15, 1901.
25. *The New York Times*, June 8, 1901.
26. *Proceedings of the New York State Stenographers' Association, Including Papers Read, Discussions, Etc., at the Twenty-Sixth Annual Meeting, 1901*.
27. United States Congressional serial set, Contingent Expenses of the Treasury Department, February 4, 1901.
28. *The Times*, Washington, D.C., May 23, 1901.
29. *The Evening Times*, Washington, D.C., July 30, 1901.
30. *The Washington Post*, Washington, D.C., August 1, 1901.
31. *The Evening Star*, Washington, D.C., November 21, 1901.
32. United States Congressional serial set, Expenditures in Department of Agriculture, October 22, 1904.
33. Annual Report of the State Board of Assessors of New Jersey, 1900-1906.
34. Otto Burghagen, *Schreibmaschinen-Zeitung*, Hamburg, no. 84, June 15, 1905.
35. *The Washington Times*, Washington, DC, April 8, 1905.
36. *Obsolete American Securities and Corporations*.
37. *Western Electrician* (Chicago: Electrician Pub. Co.), February 2, 1901.



# Demystifying the McCool

by Madeleine Allen

William Allen McCool set out to invent a simpler, more compact, and less expensive typewriter, specifically of the type wheel variety. This goal would be realized in the production of the McCool No. 2 typewriter; however, it would not be a commercial success. A paucity of information has shrouded the story of the McCool typewriter and its unfortunate demise. Why, with such a promising start and backed by the talents of a prolific and successful inventor, would it fail, destined only to become a scarce and desirable machine to future typewriter collectors? My fortuitous discovery of a McCool No. 2 in April 2012 and Richard Polt's request that I share its story in *ETCetera* prompted me to start searching for answers. I have attempted not only to fill in the gaps of what we already know but also to piece together a fuller story of W. A. McCool's typewriter and the company that produced it.

What is generally known of the McCool typewriter is that it was invented in 1903, marketed in 1909, patented in 1910, made by the Acme-Keystone Manufacturing Company of Beaver Falls, Pennsylvania, constructed from 319 parts, and sold at the economical price of \$25. McCool's vision for his typewriter originated at least as early as 1902 when he formed the New York-Pittsburg Manufacturing Company. This



company was organized exclusively for the manufacture of typewriters and blind-stitch sewing machines, and was located at the former site of the Shelby Tube Steel Company in Beaver Falls. This location was also known as the for-

mer Cutlery Works property, and had housed the former Eclipse Bicycle Company (with which McCool was associated), then later the McCool Tube Company (which was absorbed by the Shelby Steel Trust in 1900), all of which gave their address as 220 7<sup>th</sup> Avenue. A fire in August of 1900 destroyed the entire property except for one building, which the New York-Pittsburg Company occupied in 1902. McCool filed five separate patents related to his typewriter and its mechanisms, with the primary patent filed June 19, 1903 and patented July 12, 1910. A *Beaver Times* article from September 1903 reveals that McCool was not only making preparations to get his typewriter on the market, but also had a model machine built and was hard at work perfecting the design. Might this shed some light on why all known manufactured (hence "improved and perfected") McCool typewriters are model No. 2s?

1905 saw the beginning of significant changes for McCool's typewriter and sewing machine company. By June of 1905, the New York-Pittsburg Company had merged with the Union Specialty Manufacturing Company and applied for a charter to do business under the new name. A *Daily Tribune* article from June 5, 1905 states that ground was broken that morning for the construction of a new factory, a modern two-story brick building at 7<sup>th</sup> Av-



enue and 3<sup>rd</sup> Street in Beaver Falls. This new factory would be just south of the factory belonging to the Union Drawn Steel Company, which McCool also founded when he successfully brought cold drawn steel tubing to the Beaver Falls area in the late 1800s. The article also mentions the McCool typewriter will be manufactured and that it “is a visible writing machine, substantially built to be sold at a moderate rate, which is destined to become the machine to be used by the masses.” As a legal necessity, the Union Specialty Company would officially change its name to the Acme-Keystone Manufacturing Company in 1906.

I was unable to find much else about McCool, the typewriter or the company again until 1909. In June 1909, *The Kissimmee Valley Gazette* confirms that the McCool typewriter was being placed on the market. We know that Acme-Keystone actively advertised the McCool No. 2 typewriter in various publications throughout 1909. The ads touted the typewriter’s many benefits along with how large, expensive and able their factory was. It would seem that McCool had high hopes for the success of his typewriter, but if so, why did Acme-Keystone only advertise the McCool in 1909? Lastly, in October 1909, there is a brief notice in the *Daily Times* from the Board of Directors of the Acme-Keystone Company about a December meeting to vote on increasing the indebtedness of the company. (I did come across brief ads placed by an independent typewriter dealer as late as March 1910 in the *Dallas Morning News*. One of these ads, placed by the Mercantile Trading Company of Dallas, stated, “See the new McCool typewriter, price \$25. Equals any high-priced machine. Agents wanted.”)

1910 would prove to be a fateful year for Acme-Keystone and the McCool typewriter. On April 9, a large fire broke out in the Union Drawn Steel factory, which then spread to the Acme-Keystone factory, entirely destroying both buildings. Also completely lost in the fire were costly machinery used to make the typewriters and sewing machines, and partially completed machines and stock. Company directors met the next day and the consensus was to rebuild the factory and continue production of the machines. However, losses were estimated to be anywhere from \$200,000



The Home of "THE MCCOOL"

to \$500,000 and it is likely that the company was insured for only \$100,000. A *Daily Times* article from April 22 states that Acme-Keystone was installing machinery in their office (the 220 7<sup>th</sup> Avenue location) to manufacture the sewing machines but would not resume manufacture of the typewriters until the factory could be rebuilt. The article also interestingly mentions that the Union Drawn Steel Company was making negotiations to purchase the property of



W. A. McCool's Residence.

Acme-Keystone near its plant. While a May 27 *Daily Times* article states that the Acme-Keystone Company was still cleaning up from the fire, and making plans to rebuild an even larger factory, it would seem the plant was never rebuilt for use by the company. A *Beaver Falls Tribune* article from September 1913



reveals that the ruins of the Acme-Keystone plant were still there and posing a risk to traffic. The article also confirms that the company was still residing at its office at 220 7<sup>th</sup> Avenue.

By February 1912, Acme-Keystone was in receivership. A notice posted to the *Daily Times* shows that due to a court case (W. A. McCool Jr. vs. Acme-Keystone) originating from September 1910, a receiver’s sale of all the typewriter and sewing machine patents would take place on March 2, 1912. Another interesting notice posted in the *Daily Times* on May 17, 1912 reveals the contents of a receiver’s sale of personal property from the Acme-Keystone Company’s office. The items include 1 Junior typewriter (likely the 1907 type wheel version invented by Bennett), 8 typewriters and parts (possibly McCools), and 12 new McCool No. 2 sewing machines. One can speculate that the company was studying the Junior and its mechanisms, possibly for patent infringement or ideas. I did not come across mention of Acme-Keystone again until 1922 when a business directory listing shows it was still located at 220 7<sup>th</sup> Avenue and had only three employees. This would appear to be the end of the story for Acme-Keystone and its McCool typewriter. Union Drawn Steel eventually purchased Acme-Keystone’s factory property (which in 1927 they planned to turn into a playground), plus their office at 220 7<sup>th</sup> Avenue, which in 1947 was listed as Union’s office address. Today, Keystone Profiles, affiliated with the former Union Drawn Steel, resides at that same location and we can only wonder if the Keystone in their name is homage to the company that once owned the building there.

Can the factory fire and resulting heavy losses explain why the McCool typewriter failed? It would certainly seem that Acme-Keystone did not recover after such a devastating loss. It is highly unlikely that any new McCool typewriters were produced after the fire. It also seems that most of the unsold typewriter stock perished, and this would explain the abrupt stop to advertising in 1910. McCool was getting older at this point, and spending at least half his time in Florida. While he experienced much success in his other ventures and was a respected member of his community (even establishing the area’s first country club), the significant Acme-Key-

stone Company losses likely forced him to abandon the ambitious plans he once had for his typewriter. McCool's typewriter is certainly scarce today. With the help of Thomas Fürtig's serial number list, we currently know of 15 existing McCool typewriters, ranging from 718 to 2084. During my research for this article, I was very excited to discover a McCool No. 2, serial number 1580, owned



by the Beaver Falls Historical Museum (located in the Carnegie Free Library, Beaver Falls). The typewriter had been donated years ago by longtime Beaver Falls resident I. W. Pettler. Another museum McCool typewriter, owned by the Milwaukee Public Museum, is serial number 2040.



My McCool, serial number 1821, was discovered in Easton, MD. All the seller could tell me was that his late father had bought it at auction many years earlier, and then it had been sitting in his basement for several years. My McCool came in its original case, with a burgundy colored felt lining, its rubber impression

strip, and a mysterious small wooden block. The assumption is that this triangular wood block was placed in the space between the front and rear hammer rails to prevent the hammer from moving back and forth during shipping. We can only wonder if Acme-Keystone shipped all new typewriters with this piece in place, or if it was a solution crafted by a former owner. According to a McCool trade catalog, quite likely the same one a prospective buyer received when responding to one of the 1909 ads, the carrying case could be had for only an additional \$2.50 when purchased with the typewriter. Additionally, when ordering the McCool, the buyer had a choice of five different type wheel font styles, and purple (standard), black or blue ribbon.

The McCool typewriter itself can be seen as an amalgamation of parts from several other typewriters. It has a type wheel similar to the Blickensderfer, utilizes a rear-striking hammer similar to the Commercial Visible (and Hammond and Chicago), has a sliding hammer support arm similar to the Chicago, and uses a rubber impression strip similar to the Hammond. One unique thing about the McCool is its celluloid parts, specif-

## Who Wants a Typewriter?



**P**RETTY nearly everybody wants a typewriter. But few of us want to pay as much as \$100.00 for one. Up to about now typewriters have been classed along with diamonds— They are mighty nice things to have, but they cost money! They are a luxury!

It has been generally supposed that a business house must be just so big, that a merchant must have just so much business, that a lawyer and other professional and business men must have just so much work before they *can afford* a typewriter.

It was just so with sewing machines. And later on with bicycles and automobiles.

Nowadays almost every home has a sewing machine.

Bicycles dropped all the way from \$150.00 down to fifty, forty, thirty. Every year the automobile is getting cheaper and better.

Who knows but that we will live to see the day that each one of us will have our automobile and flying machine.



**T**HE American is the greatest being in the world to make short cuts. Somebody will invent a machine that works wonders. It may be quite complex at first, but just so long as it does its work well it very quickly becomes popular.

Then another genius comes along and cuts out about half the parts and thereby reduces the cost. He also improves the machinery to make it; by and by produces the same effect or does the *same work* with a machine that is *much simpler* and *costs only a fraction of the original price.*

cally its front faceplate and back cover. One can only assume that this unusual feature, especially on a machine touted for business use, was to keep costs as low as possible. To me personally, the McCool is most similar to the Commercial Visible 6 in action and feel, as they were both economical type wheel machines. Both also utilized a three-row double-shift keyboard and a traditional ribbon inking system, and produced visible typing. The McCool does use a hammer support arm that extends out from the machine to place the hammer in correct position (in the middle) for typing. When a key is struck, the hammer hits from behind, and against a rubber impression strip behind the paper.

Finally, Mike Brown mentioned in his 1997 *Typewriter Exchange* article that he believes there is an error in Paul Lippmann's claim of a manufacturing connection between the McCool, Keystone and Sterling typewriters. In light of this new information about Acme-Keystone, I am inclined to agree that no evidence exists to support the claim that the company produced any typewriters other than the McCool. If anything, my findings highlight the fact that further research is still needed to answer all of the mysteries surrounding W. A. McCool's typewriter. ■

*McCool trade catalog courtesy of the Peter Weil collection. I am grateful to Mike Brown, Peter Weil, Thomas Fürtig, Travis Hamric, and the staff of the Beaver Falls Historical Museum for their support and assistance with this article.*



### Sources

- Beaver County, Pennsylvania: A Photographic Souvenir in its Centennial Year, 1800-1900.* Beaver, PA: 1899-1900.
- "Fire Destroyed Plants." *Youngstown Vindicator* (Youngstown, OH), Aug. 9, 1900.
- "A New Plant for Beaver Falls." *Beaver Times* (Beaver, PA), Apr. 15, 1902.
- "Model is Built." *Beaver Times* (Beaver, PA), Sep. 25, 1903.
- Bausman, Joseph. *History of Beaver County, Pennsylvania: And Its Centennial Celebration, Vol. 2.* New York: Knickerbocker Press, 1904.
- "Building a Big Plant." *Daily Tribune* (Beaver Falls, PA), Jun. 5, 1905.
- "Union Specialty Company Seeks to Change Its Name." *Daily Tribune* (Beaver Falls, PA), May 9, 1906.
- "The Seamans Go." *Kissimmee Valley Gazette* (Kissimmee City, FL), Jun. 18, 1909.
- "Office of the Acme-Keystone Mfg. Co., Beaver, Pa." *Daily Times* (Beaver, PA), Oct. 16, 1909.

- Weekly Underwriter, Vol. 82.* New York: The Underwriter Printing & Publishing Co., 1910.
- "Typewriters and Supplies." *Dallas Morning News* (Dallas, TX), Feb. 15, 1910.
- "Beaver Falls Visited By Fire That Caused Million Dollar Loss to Two Large Factories." *Daily Times* (Beaver, PA), Apr. 11, 1910.
- "McCool Typewriter Works Burned." *Kissimmee Valley Gazette* (Kissimmee City, FL), Apr. 15, 1910.
- "Clearing Away the Debris." *Beaver Times* (Beaver, PA), Apr. 22, 1910.
- "Brief News Notes at Beaver Falls." *Daily Times* (Beaver, PA), May 27, 1910.
- "Receiver's Sale of Valuable Patents." *Daily Times* (Beaver, PA), Feb. 20, 1912.
- "Receiver's Sale of Personal Property." *Daily Times* (Beaver, PA), May 17, 1912.
- "Factory Walls Are Dangerous." *Beaver Falls Tribune* (Beaver Falls, PA), Sep. 11, 1913.
- Fourth Industrial Directory of the Commonwealth of Pennsylvania.* Harrisburg: J. L. L. Kuhn, 1922.
- "Union Drawn Steel Co. to Provide Playground for South End Kiddies." *Beaver Falls Tribune* (Beaver Falls, PA), May 5, 1927.
- Derby, George. *The National Cyclopaedia of American Biography.* Vol. 33. New York: J. T. White & Co., 1947.
- "Country Club Founded by W. McCool." *Milestones: The Journal of Beaver County History*, 13 no. 3 (1988). <http://www.bchistory.org/>
- Cox, Margaret. "The Growth of Beaver Fall's First Cold Finished Bars 1889-1989." *Beaver County History Online*. 1989. <http://www.bchistory.org/>
- Brown, Michael. "McCool: The Inside Story." *The Typewriter Exchange* 9, no. 4 (November 1997): 185, 190-191.



# Back to Basics

## A Platen Primer

by Klaus J. Brandt, Norderstedt, Germany

(Member no. 9 of IFHB, Historical Office World International Forum)



A typewriter is a technical miracle consisting of thousands of individual pieces. One very important piece is the platen, which is crucial for precise typing, good copies, a well-aligned advance of the paper, noise control, and readiness for work. The platen consists of a cylindrical wood or metal core covered in rubber; it requires a precise diameter and a hardness appropriate to its use.

Rubber is subject to natural decay and loses its elasticity over time, so that with an old, hardened platen you can get only poor writing—and you damage the typebars and other sensitive pieces, due to the lack of elasticity on the rebound. The ribbon also wears out before its time.

A typewriter in an important position can be subjected to over 30,000 keystrokes a day, which eventually hammer permanent hollows into the rubber surface, so that one needs to recover a platen regularly every 1-2 years.

The platen of a single-element typewriter requires a special blend of rubber, and this has to be taken into account without fail. A professional platen recovering has to be done by an office machine professional who knows how the typewriter is being used.

The platen is removed by a mechanic either in its place of use or in the workshop; then a business that specializes in recovering platens does the job, considering the brand of typewriter and using a rubber sleeve of hardness appropriate to the number of copies desired by the customer. When reinstalling the platen, one has to eliminate any play or slippage of the variable spacing mechanism.

If a typewriter is used to cut wax stencils for mimeographing, then the platen and feed rollers have to be acid-free. You can recognize these platens by their brown rubber (it isn't cork).

At the end of the platen recovering process, the old rubber is removed from the core, a fresh “raw” rubber sleeve of the right hardness is chosen, and it is shrunk when warm onto the metal core. Then the platen goes onto a special lathe that rotates it and grinds it to the right diameter, making it perfectly smooth and cutting the edges neatly.

Here's some original ad copy from one of the greatest specialists: “Platen covers of all dimensions—Every piece fully guaranteed—Prompt delivery even of larger quantities, either raw for your own turning or ground to original diameter. For every friction process (with spinning disk) or rotation process (with Widia steel), in every desired diameter—all lengths up to 1050 mm—various degrees of hardness.”



*Disassembled Continental standard platen*



*This piece of the Continental's platen is marked “Links” (left) and shows 7.42 (July 1942) as the date of manufacture.*



*A look inside. The platen must be adjusted for precise performance.*

### Where Can You Get Your Platens Recovered?

In the US, Ames Supply Company specialized in recovering platens—a business that the company practically invented 110 years ago—but it is now out of business. Happily, J.J. Short (a rubber products specialist near Rochester, N.Y.) has stepped in to fill the need. Write to Peter Short (pjshort@jjshort.com) to get a quote, providing the following information: the inside diameter of the rubber or the outside diameter of the core without the rubber; the current outside diameter of the platen; and the length of the rubber. In Germany, contact P. Röhlig (p-roehlig.de) or Eveline Theobald Büromaschinen (schreibmaschinenhaus.de). In France, contact Early Typewriter Collectors' Association member Marc Pellacoeur (bardamui81@sfr.fr). —Richard Polt

# Ephemera by Peter Weil . . . . The Last Maskelynes



This presentation attempts to answer questions about a newly-discovered piece of ephemera, a small, 4 inch by 3.5 inch, black and white snapshot of a typewriter with a half-moon arc of typebars that looked familiar to me. The familiarity immediately was confirmed by the name “MASKELYNE” on its spacebar. But the longer I looked at it, the more I was convinced that the machine pictured was not like any Maskelyne<sup>1</sup> I ever had seen in any of the standard sources on the history of typewriters. Without the name on its spacebar, the machine’s metal top gave it an almost “modern” look, resembling the portables of the 1930s made by Remington, Smith-Corona, and others. While I felt sure that no Maskelyne could have been produced that late, I also



knew that the company was known for its innovation. So, I had to consider the possibility that the typewriter in the photograph might have been an earlier design that had been discarded. Therefore, I began researching the evidence for the history of the typewriters produced by the Maskelyne Type Writer Company, Ltd, the first manufacturer in the UK of a British-designed typewriter (see logo<sup>2</sup> and company stock certificate<sup>3</sup>

issued in 1896).<sup>4</sup>

The company was founded by John Nevil Maskelyne and his son who shared his name. By the last half of the 1880s, the father was known as a world-famous magician. This notoriety immediately preceded the Maskelynes’ first typewriter patent, when the father had already begun a career of invention. Those creations ultimately included the first successful



fare collection machine for buses and the first successful coin-operated door for pay toilets. John Nevil Sr.’s stature as a magician was strongly based upon his development and stage presentation of mechanically-based illusions, the most famous of which was Psycho, an automaton that played whist and did other tricks that amazed his audiences. Shown here is a photograph of the senior Maskelyne performing with his early robot in 1875.<sup>5</sup> Born in 1839 in England and trained



as a clockmaker, the senior Maskelyne developed an interest in magic after watching a stage performance by a spiritualist whom Maskelyne quickly revealed to be a charlatan. He combined forces with a highly skilled cabinet-maker and by the 1870s he had established his reputation as a conjuror, setting up a base of operations at Egyptian Hall in Piccadilly Square in London.

In this context, by July, 1889, the father and son had submitted their first, highly innovative applica-

ous permission of Heidi and Marco Frei, who own the original certificate and all rights to its reproduction.

1. Pronounced “Máskülín.”

2. The logo is from an accessory cover to serial #1243 in the Gertrud Barbian Collection. Such a typebar cover was an extra cost item and the typewriter would not function with it on (image provided by Gertrud Barbian). See image below of serial #1190 showing the complete cover. The company owning the rights to the Maskelyne appears to have had possibly two other corporate names between 1896 and 1898. One was “The Maskelyne Typewriter and Manufacturing Company, Ltd.” (from *Register of British Industries Classifieds*, July, 1896) and the other was “Maskelyne British Typewriter Company, Ltd” (1897-1898). Based on the legal issues surrounding the receivership in 1897 and loss on appeal the next year (see below), the latter was the last name used.

3. The use of this image of the stock certificate is made possible by the gener-

4. My research on Maskelyne Typewriters was greatly aided by several collectors and curators. I especially want to thank Bert Kerschbaumer for the effort and time he devoted to providing me with sources, names, and a wide variety of information. Vital assistance also was provided by Thomas Fürtig, Ed Neuert, Paul Robert, and Alan Seaver. Help from others was essential, including that of Gertrude and Hans Barbian, Uwe Bethmann, Uwe Breker, Sophia Brothers (Science Museum), Mark Frankena, Heidi Frei, Al Muchka (Milwaukee Public Museum), Fritz Niemann, Herman Price, Darryl Rehr, Rebecca Storr (Science Museum) and Jon Williams (Hagley Museum). Any errors or other problems in the article are the author’s alone. I also want to express my appreciation to Cornelia Weil for her editorial suggestions.

5. [cyberneticzoo.com/wp-content/uploads/Psycho-Maskelyne-01-x640.jpg](http://cyberneticzoo.com/wp-content/uploads/Psycho-Maskelyne-01-x640.jpg)

tion for a “type-writing machine” to the United States Patent Office, which was granted two years later.<sup>6</sup> The design included several unique features, including differential (i.e., proportional) spacing and a “grasshopper” typebar. The father’s primary contribution to the new typewriter was the complex escapement system operated by four universal bars to create the mechanics needed for the differential spacing. Moreover, his fame was the basis of much of the attention the first examples of the machine received from the public and the press. The patented design resulted in prototype examples that were shown and demonstrated at Egyptian Hall and at the Universal Exposition in Paris in 1889.<sup>7</sup>

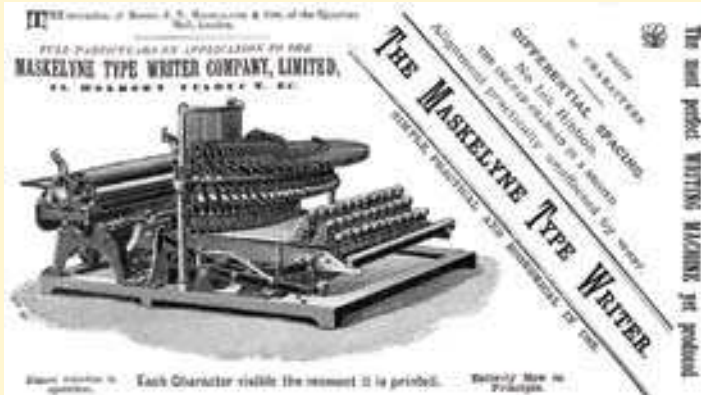

What did these early examples look like? No specific machines from this early period are known to survive. There also are no known surviving examples of an extremely similar machine that may have been made in very small numbers that was probably marked as an “S No. 2,” i.e., Series or Model Number 2.<sup>8</sup> This etching from an 1892 advertisement<sup>9</sup> and drawings from the first patents provide a fairly clear conceptualization of these two machines, the prototype and the Number

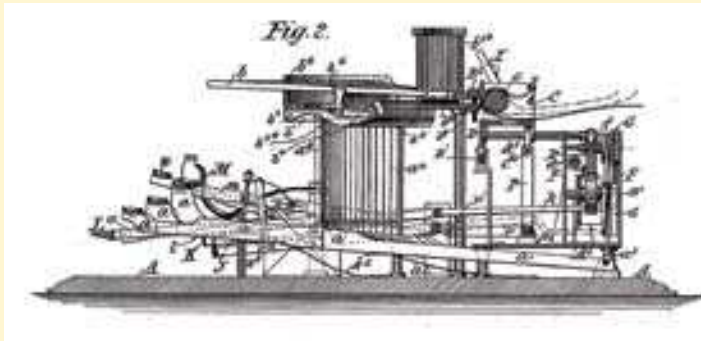

6. U.S. Patent number 457903. A British patent, CA 44259 A, including virtually the same drawings and claims, was granted soon after in the UK.

7. *Reports of the United States Commissioners to the Universal Exposition at Paris of 1889*, vol. III (Washington, D.C.: U.S. Government Printing Office, 1891), p. 59.

8. In Dingwerth (*Kleines Lexikon Historischer Schreibmaschinen*, 1997, p. M025), his first and second models are the same as the first two designated here.

9. The earliest advertisement discovered in the research for this article was published in a pamphlet published by Maskelyne Senior about his Egyptian Hall shows. There is a review of one of them dated 1891, and thus the ad is no earlier than that date. The ad promises that the “Maskelyne Type-Writer” will “soon be placed upon the market.” This was very likely published at some point in 1892 at a point in time before the first ad actually selling the machine. Both include a drawing of the earlier model.

2, of the same basic design.<sup>10</sup> The 1892 advertisement etching shows a machine extremely close to the one described by the drawing in the 1889 U.S. patent application. This original design clearly shows the grasshopper typebar arrangement with its use of a pad inking system involving a horizontal plate near the platen topped by an upward-facing inkpad on which the types rested. These typebar and inking features of the early prototypes and machines used for testing (illustrated here in the first patents) was also retained in the manufactured machines of 1893. Note the position of the types at the end of the typebars resting on the pad near the platen in this example with serial number 1246.<sup>11</sup> Moreover,

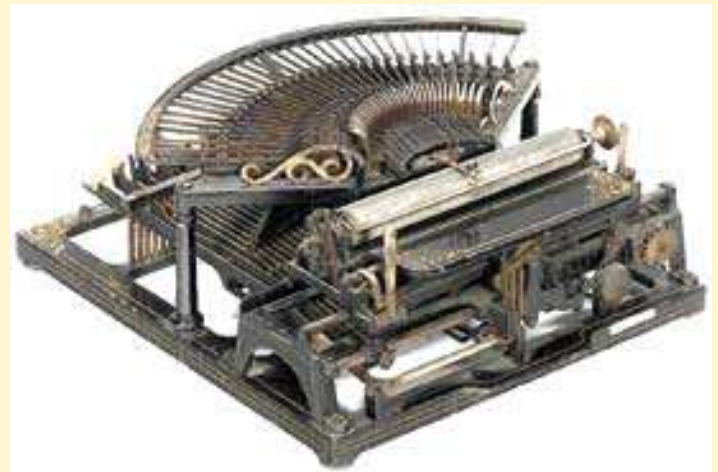
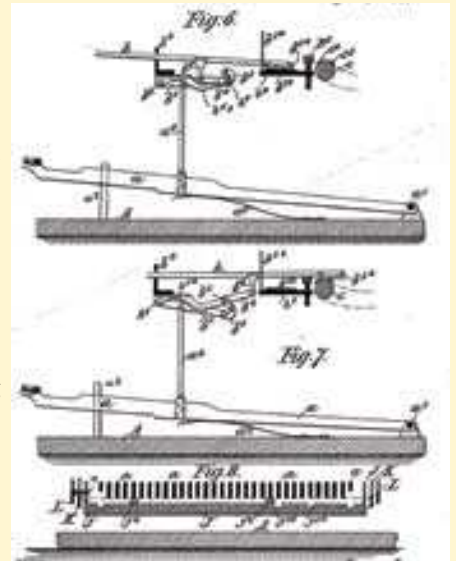

as observed by Mares, the original design included a “peculiar-looking grill between the bars of which” the typebars moved.<sup>12</sup> In addition, prototype Maskelynes were fitted with rubber types,<sup>13</sup> but the Number 2 machines probably had those replaced with steel types.

10. The etching is the earliest ad discovered for the actual sale of the second model. It was published in *London and Fashionable Resorts*, 1893, p.163. It also is virtually the same as that published in *Dinglers Polytechnisches Journal*, vol. 10, 1891, p. 232. The patent illustration is from U.S. Patent number 457903 issued in 1891.

11. Auction Team Breker, 2008 *Spezial Auktion: Büro –Antik, Spielzeug, Wissenschaft und Technik (Katalog)*, 22 November, lot 211.

12. G.C Mares, *The History of the Typewriter, Successor to the Pen* (Arcadia, CA: Post-Era Books, 1985) (originally published in 1909), p. 118.

13. Ernst Martin, *Die Schreibmaschine und ihre Entwicklungsgeschichte* (Delbrück: Verlag für Sammler-Literatur, Dingwerth GmbH, 2003) (originally published 1949), p. 139. Note also that the experimental version of the Haldal that was noted in Uwe Bethmann’s article in the last issue of *ETCetera* (No. 99, September 2012, pp. 3-5) appears to have simply been a result of Haldal’s copying aspects of this early model, and not involving any formal or contractual arrangements with Maskelyne (personal communication from Uwe Bethmann, September 23, 2012).

While the 1892 ad for an early model of the Maskelyne is evidence that there was a real attempt that year to place a Maskelyne (probably a Number 2) on the market, the other evidence supports the conclusion that the initial effort failed and it was not until 1893, when the company had developed a new Number 3 model, designated “S No. 3,” that a full and somewhat successful marketing effort was undertaken. This same year, 1893, is the one that is designated by Martin.<sup>14</sup> Beyond support from Martin’s assertion, my conclusion is made with other evidence that contradicts authoritative assertions, such as Richards’ and Adler’s,<sup>15</sup> that the first Maskelynes were sold to customers in 1889.<sup>16</sup> Reviews from 1893 of the Maskelyne published in both the U.K. and the U.S. support the later date of what was then stated to be a new typewriter on the market.<sup>17</sup> Especially strong evidence for that year is found in the British review, which included information from an interview with J.N. Maskelyne Sr. The appraisal includes the following: “Some years have been spent in [developing] the production of a machine realizing Mr. Maskelyne’s ideal, and as the Maskelyne Typewriter has now [1893—my emphasis] taken its place among the writing machines offered to the public, we have the pleasure of furnishing information respecting it....Mr. Maskelyne explains that the delay [my emphasis] in placing his Typewriter on the market has been due to the extensive experiments he has made with a view to simplifying its construction and movements.”<sup>18</sup> These statements shed light on a comment by Jasper Maskelyne that is probably related to activities during the delay. Jasper notes that in 1890, his grandfather (J.N. Maskelyne Senior) ran a typing service at Egyptian Hall to produce

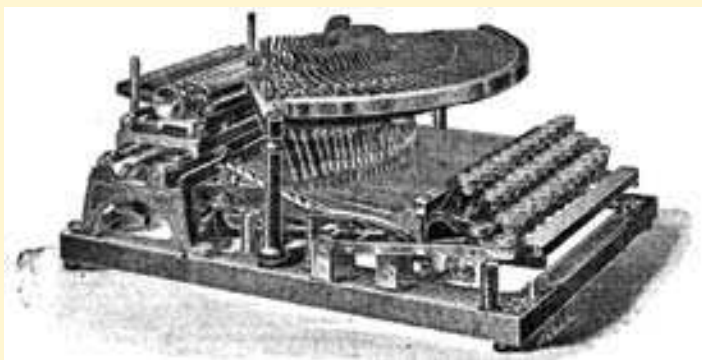

14. Martin 2002, p. 139. Martin sees this year as the one that the second model of the Maskelyne was introduced, with the third model being introduced soon after in the same year. The third model was virtually the same design with the addition of a feature, interchangeable carriages of different lengths. Martin is the only source that mentions this feature.

15. G. T. Richards, *Handbook of the Collections Illustrating Typewriters* (London: Board of Education, Science Museum HMSO, 1938), p. 37; Michael Adler, *Antique Typewriters: From Creed to QWERTY* (Atglen, PA: Schiffer Publishing Co., 1997), p. 160. Others include *Typewriter Topics 2000* (1923), “Maskelyne”; *The Typewriter: An Illustrated History*, p. 43; and *Imperial Typewriter Museum Collection* (Leicester, UK, 1963).

16. Dingwerth (*Kleines Lexikon*, p. M027) treats this design as the third model. He has the model presented here as the Number 3 not being introduced until 1897, which is contradicted by images in an advertisement that dates from 1893 and by the 1893 date of one of the reviews.

17. Note that the Maskelyne Typewriter was shown at the Columbian Exhibition in Chicago in the same year, 1893. See the *Catalog of the Chicago Exhibition, 1893, British Section*, p. 220.

18. “The Phonetic Journal: The Maskelyne Typewriter,” *Pitman’s Journal of Commercial Education*, vol. 52, December 2, 1893, p. 756. The U.S. review was E. N. Miner, “The World’s Latest in Typewriters: The Maskelyne,” *Journal of Commercial Education*, vol. 9, September, 1893, p. 29.

legal and scientific documents.<sup>19</sup> It is probable that the typing service was a means to test and develop the design of the typewriter, helping it to achieve an acceptable form for the market.

The design of the Maskelyne Typewriter offered for sale in 1893 was very similar to the first offering in the previous year. The overwhelming evidence in the form of all but the earliest of the seven surviving examples of Maskelynes of this basic design is that the typewriter the company first fully marketed in 1893 was the Number 3 model.<sup>20</sup> The new design of the Number 3 involved an obvious modification that included the elimination of the vertical rods at the top that aligned the movement of the typebars and their replacement with low, small guides (Mares calls the new structure a “comb”), as seen in this illustration (*left*) from the *Pitman’s* 1893 review. Moreover, in the interim between the development of the first two models of the 1889-1892 period and the placing of this modified design on the market, J.N. Maskelyne Junior obtained a U.S. patent, number 484435, for a somewhat modified typebar and key lever arrangement, that appears to have also been included in the 1893 machine. The new patent retained the original position of the types on top of the inking pad and with both in a resting position close to the platen, as seen in this drawing from the 1892 patent.<sup>21</sup>

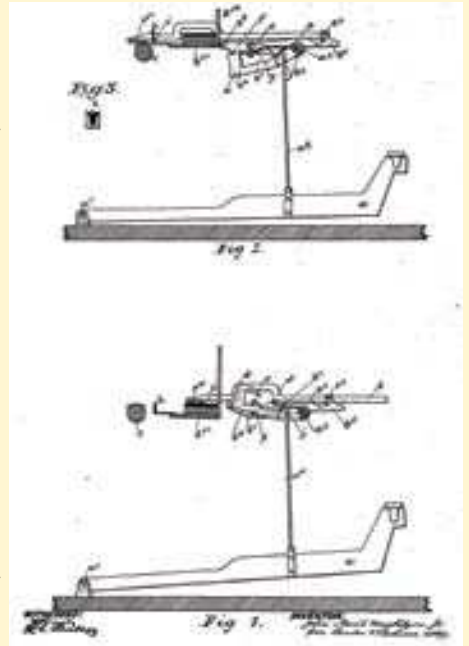

So, the question now turns to the models produced for sale by the Maskelyne Typewriter and Manufacturing Co. that survive—how can they help us explain the typewriter in the snapshot? I have identified eight definite surviving Maskelyne Typewriters.<sup>22</sup> Seven of these have the characteristics of the third model and one of The Victoria. The serial numbers of the confirmed third model survivors are 1171, 1190, 1243, 1246, 1522, and 1585. Serial #599, because of the characteristics

19. Jasper Maskelyne, *White Magic: the Story of the Maskelynes* (London: Stanley Paul and Co, Ltd, 1936), p. 53.

20. Six were confirmed as having the engraved “S No. 3” on the left front frame under the spacebar. The confirmation was through examining their photographs or by email with their private owners and a museum Curator, Al Muchka (MPM). The photograph of #599 could not be used for this purpose.

21. By the time of this introduction, the rubber types had been replaced with metal ones. The exact date for this change is not clear, but this would have been the latest point for this change. See Martin 2003 (1949), p. 139.

22. Two others may exist, but no definite identification has been made. These include one formerly held by the Imperial Typewriter Co. in its historical collection. It appears likely that this one from the liquidated Imperial Collection is one of the identified survivors. Moreover, Martin (2003 [1949], p. 140) suggests that one was held by the Deutsches Museum in Munich, but Bert Kerschbaumer checked with the curator and found that their collection today does not include a Maskelyne typewriter nor any record of its being part of the collection.





#599



#1171



#1190



#1243



#1246



Cover



#1522



#1585

it shares with the other survivors, is very probably a Number 3. Images of these survivors are shown here, from the lowest and earliest to the highest and newest.<sup>23</sup> Also shown is the optional cover for the whole

23. In this order, they are from the collections of Uwe Breker (serial number 599, with photograph), The Milwaukee Public Museum (serial number 1171 identified by the curator, Al Muchka; photo from the Mark Frankena collection—originally made by Darryl Rehr and used in his 1997 book *Antique Typewriters*—and use here recognizes the holding of reproduction rights in it by the Milwaukee Public Museum), Heidi Frei collection (serial number 1190, with photograph), Gertrud Barbian collection (serial number 1243, with photograph), the ex-OHA Collection machine (serial number 1246, sold by Team Breker in 2008), Scottish Transport and Industry Collections (serial number 1522 and accession number T.1934.193), and The Science Museum

machine available from the company for the Number 3 model.<sup>24</sup> All six marked Number 3 survivors (and the probable Number 3, #599) are strikingly similar, with the most obvious visual difference involving the variations in spacebars. Earlier survivors tend to have simple wooden spacebars, whereas survivors after serial number 1171 tend to have spacebars made of two levels, with the upper one bearing the name of the manufacturer. Most noteworthy is that all appear to have

(serial number 1585; this photograph is provided by the Science Museum / Science & Society Picture Library and its use in *ETCetera* is with its written permission; ownership of and use rights to the photograph belong to that institution).

24. Found with serial #1171. Heidi Frei collection.

the same basic typebar design that characterizes the first two previous models. None have the typebars, ink pad system, or tabulator that are described as parts of the design of The Victoria by most writers and by Martin as being on a later, fourth model. As to the question about what Maskelyne model is in the snapshot, the Number 3 model marketed in the 1893 is definitely *not* that typewriter.

Between 1894 and 1897 a major new model replaced the the first fully-marketed design, the Number 3. Most sources that take note of the new model, other than Martin, call this new Maskelyne “The Victoria” and specify that it was introduced in 1897.<sup>25</sup> It was not until this image of The Victoria was made available for this article by the Science Museum (UK)<sup>26</sup> that the name “Victoria” (on the left side of the spacebar) and the manufacturing date, 1897 (on the right side of the spacebar) could be confirmed with such concrete evidence.<sup>27</sup> Below the spacebar, before the #8 serial number, this model is also designated as “Series A.” The change in design, seen so clearly in this example and in a more limited way (because of the perspective) in the Maskelyne in the snapshot, was based upon a new U.S. patent, number 560142, applied for in December, 1894, and awarded in the U.S. in 1896 and assigned to Nevil, the son. A drawing included in the patent is shown here.<sup>28</sup> The most obvious modification, visible in both photographs and the patent, is a new typebar and inking design,

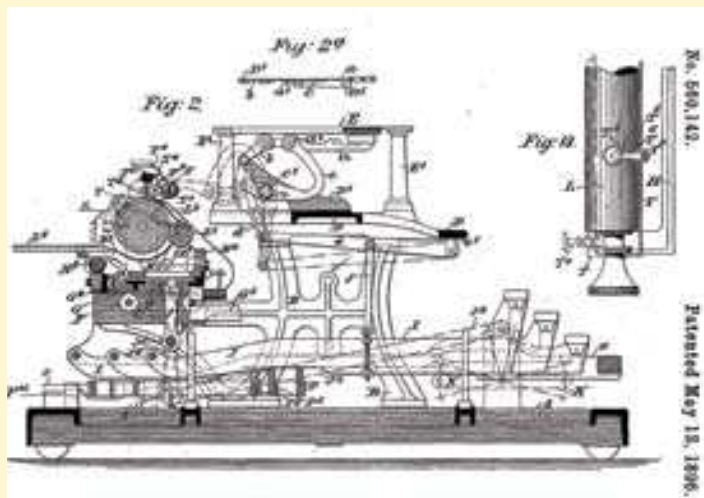

with the typebar reversed relative to the older one and with the types now resting pointing up against an inkpad that points down. Moreover, the types are now at rest just behind and over the keys and move in a complex manner anticipating important aspects of the front-strike design found a decade later on the Yost #15 and later models.<sup>29</sup> Most remarkably, the type had to somersault in order to strike a point on the platen. In addition, a columnar tabulator and a back spacer were added.<sup>30</sup> In addition, Richards (1938, p. 43), in his catalog for the Science Museum, states that on The Victoria, full differential spacing was retained for all types.<sup>31</sup>

The Victoria in the Science Museum’s photograph and the Maskelyne model in the snapshot do share several of the features specified in the patent application containing the features.<sup>32</sup> However, the two typewriters have several features that are different from each other.<sup>33</sup> These similarities and differences might most easily be seen by reviewing the two images here. Both machines share the same basic

25. Richards 1938, p. 43 and Adler 1997, p. 160, give 1897 as the date for the introduction of the #3.

26. This photograph is provided by the Science Museum / Science & Society Picture Library and its use in *ETCetera* is with their written permission. Ownership of and use rights to the photograph belong to that institution.

27. The name “Victoria” was probably selected because 1897, the year of the model’s formal introduction, was the same as that celebrating the Diamond Jubilee of the reign of Queen Victoria.

28. The same drawings and other drawings and descriptions were included in the successful patent applications granted in 1895 in the UK (GB 1894117862 (A)) and in Germany (No. 81477).

29. This typebar design has some parallels to that of the Jackson that was first marketed in 1898. However, much of its action appears to have been closer to the “grasshopper” designs on the first Maskelyne models.

30. In addition to the patents, see Martin 2003 (1949), p. 139.

31. This is supported by evidence from the typewriter in the image; to the left of the keyboard, the Victoria retains the third shift that was used in the previous models in relation to differential spacing. Mares (1909 [1986], p. 118) is the only source that asserts that the differential spacing was eliminated for capitals and figures on the Victoria, and he appears to be incorrect.

32. The comparison that follows is constrained by the fact that the photographs present only one view of each of the two typewriters and I am not able to physically examine the machines. That said, the conclusions are my best estimate based on the analysis of the contents of the photographs.

33. The discussion of differences between the snapshot’s Maskelyne and The Victoria in the Science Museum’s photograph was greatly enhanced by suggestions from Paul Robert and Bert Kerschbaumer.



typebar and inkpad design. Both are consistent with the last patented typebar design, in the 1895 (UK and German) and 1896 (US) patent designs. The shared features include the positioning of the types on the edge of the area above the keyboard and with the types facing up towards the probable ink pad that is facing down, attached to its interchangeable plate holder (see the vertical attachments shafts with their knurled nuts on each end in the photographs). The two typewriters also share the use of metal type levers, instead of the wooden ones found on the previous three models. While both *The Victoria* and snapshot machines share these features, a careful comparison of the images of the two machines reveals significant differences. The most obvious difference can be found by looking at the spacebars, revealing that the snapshot's Maskelyne lacks the model name "Victoria" and the year "1897" on it. This and the differences in decoration are real but fairly minor variations,<sup>34</sup> but there are other more important ones concerning structure and function. Most clearly, the horizontal plate that supports the typebars on the *Victoria* is characterized by an undulating, serpentine edge, while on the machine in the snapshot, the edge is a straight one. Another design difference concerns the part that assists in aligning the typebar as it brings the type to the platen. On *The Victoria* this is a horizontal metal bar extended towards the back beyond the platen with the shape of a small "v" on its end. This works in concert with a small rectangular extension or "shoulder" on each typebar that, when the typebar is extended, arrests the downward movement of the type as the bar slips into the bottom of the "v." In contrast, on the Maskelyne in the snapshot, this alignment function is implemented through a rectangular form with a squared-off notch in it in combination with a small segmented comb that can be seen just in the center of the area in front of the platen.<sup>35</sup> Another example of differences between the two machines is the shape of the platen knob or "twirler." The *Victoria*'s has a fluted base, giving it a bell-like shape

34. In the photographs, the snapshot's Maskelyne has a paper table, but *The Victoria* does not. This may not be a meaningful difference at all because it is possible that this single known surviving *Victoria* may have had a paper table that was lost at some point in its history.

35. While the absence of this segment on *The Victoria* cannot be seen on the photograph here, its absence has been confirmed by Rebecca Storr, Collections Access Coordinator, Science Museum (UK) (personal communication, October 24, 2012).

(as on the Number 3 model), whereas the snapshot machine's knob has a cylinder-shaped base capped by a larger slightly domed knurled knob. In addition, the snapshot's machine appears to lack a serial number in the position where all the identified typewriters have one, under the right end of the spacebar. While there may be other differences, even important ones, they are difficult if not impossible to ascertain from these photographs. But the two models are definitely different.

However, the differences visible in the photographs that can be specified in and of themselves cannot definitively resolve the question of the historical precedence of either design. What is in other evidence to address the question of the historical order of these two designs? Is *The Victoria* a fourth or a later model? Or is the typewriter in the snapshot the fourth model, preceding *The Victoria*? Martin asserts that an innovative new model, with features included in the design first submitted for a patent in 1894, was produced by Maskelyne in 1894. This date conflicts with the 1897 date that appears on *The Victoria*, a machine in the Science Museum image that appears to have most of the same innovative features that Martin specifies for his 1894 model. Martin further asserts that another model, a fifth by his counting, was manufactured in 1897, the same date that is on the *The Victoria*. Martin does not describe the 1897 model and assumes the company ended all production soon after.

But the possibility that the Maskelyne in the small black-and-white photograph was a new or modified design produced after the introduction of *The Victoria* in 1897 is also based upon Martin's discussion of the history of the company's models. He briefly specifies, with no description, that a fifth model was produced in 1897. All other sources than Martin<sup>36</sup> either assume that no more models of the Maskelyne were developed or produced after *The Victoria* or they assume that additional models may have been developed and not produced. However, while possible, the creation of later models would have been under increasing financial duress. The legal record indicates that the company was unable to pay at least some of its bills by 1896, and, by 1898, the receiver had taken over the company and it was unable to continue production.<sup>37</sup> Moreover, as indicated, the Maskelyne in the snapshot either does not have a serial number in the typical location for Maskelyne typewriters or it has none and was a prototype that was never produced, which would be consistent with a design created in the midst of the financial collapse of the company. If this historical placement of the Maskelyne model in the snapshot is correct, then it probably would make Martin's assertion of the introduction of the innovative new model in 1894 incorrect.<sup>38</sup> Further support for the later historical position of the snapshot design, rather than the earlier 1894 date, comes from a July, 1896, advertisement in which the Maskelyne company sells a typewriter with the same features as those that described the Number 3 and not touting any of the new features,

36. Except Dingwerth, who specifies no models after what his designated here as the Number 2.

37. For the problems with bill paying, see *The Weekly Reporter*, March 12, 1896, p. 295. By October, 1897, the company was filing for receivership (see *The London Gazette* 1897, p. 5578). See also V. Finch, *Corporate Insolvency Law* (New York: Cambridge University Press, 2002), p. 235. Only one source argues that the company remained in production beyond 1898, claiming a date of 1910. That source is George Herrl, *The Carl P. Dietz Collection of Typewriters* (Milwaukee: Board of Trustees, Milwaukee Public Museum, 1955), p. 52.

38. If Martin is incorrect, the error may have been caused by his use of the date on the first German patent application for the new design.

THE DAWN OF A NEW ERA IN TYPEWRITERS.

# THE MASKELYNE DIFFERENTIAL SPACING TYPE WRITER.

No other Machine possesses Differential Spacing, therefore it is the most Perfect Writing Instrument yet produced.

ENGLISH INVENTION. ENGLISH MANUFACTURE.  
UNIVERSAL KEY BOARD.

32 Keys, Writing Oil Characters, Visible Writing, Presses Direct from the Type, Perfect Alignment, Manfolding Unsurpassed. Ink Ribbons entirely done away with. Speed unlimited.

FREE TRIAL. INSPECTION INVITED. INSTRUCTION FREE.

Send for Full Particulars, Free on Application.

**The Maskelyne Typewriter & Manufacturing Co.**  
HEAD OFFICE: 41, HOLBORN VIADUCT, LONDON, E.C.

such as tabulation, associated with The Victoria.<sup>39</sup> That advertisement is shown here. That said, the snapshot's typewriter, if it was a prototype, instead, could have been made in 1894 as specified by Martin—its existence as a prototype, not a marketed machine, then would not have been in conflict with the continued marketing of the Number 3 in the middle of 1896. It also should be noted that the Maskelyne in the snapshot has an alignment comb near the platen that is quite similar to the one on the design introduced in 1893 and is not at all present on the 1897 Victoria. This supports the development of the snapshot's Maskelyne soon after the 1893 design and before the creation of The Victoria. However, without further data, the historical order of the two machines, the snapshot one and The Victoria, cannot be resolved.

The commercial failure of the Maskelyne designs was the result of a series of related factors. It is clear from Mares and from the sneering 1893 American review by Miner that the Achilles' heel of the Maskelyne typewriter designs was its main claim to fame, the differential spacing design. It included the complex escapement and typebar systems that required expensive manufacturing to provide the necessary tight tolerances and utilized metals that could not endure the vibration and continuous action required in the use of a typewriter. In essence, when it was new and it worked, it worked beautifully. Unfortunately, its escapement mechanisms quickly wore and got out of tolerances, and then the typewriter worked awfully or not at all. These problems dogged a product that in the 1890s, in the midst of the 1893-97 panic in the U.K. and America, sold for \$5 more than its far more durable competitors, such as typewriters made by Remington. My guesstimate, based on the serial numbers of the surviving machines, is that no more than two thousand of the Number 3 model (including the one with interchangeable carriages) were made. Moreover, very few of the earlier Number 1 and 2 models and the post-Number 3 designs were made or sold. In hindsight, failure after no more than five years of commercial production was inevitable, leaving us to admire and to be fascinated by models of the one of the rarest and (many would say) most beautiful typewriters ever manufactured.

The Victoria was introduced by 1897 and any other designs, including possibly the one in the snapshot, created after it were probably not sold. The Maskelyne company was already in financial difficulties the year before the introduction of The Victoria, and was bankrupt and under receivership within a year after its introduction. Thus the little snapshot, the piece of ephemera, has preserved for us primary evidence of one of the Last Maskelynes.<sup>40</sup> 🐼

39. From *Wheelwoman and Society Cycling News*, July, 1896. Advertisement from the Bert Kerschbaumer collection.

40. At this writing, no surviving examples of the snapshot's Maskelyne have been identified, and the only evidence we have for its existence is in the image.



## Historische Bürowelt

No. 89, October 2012

- Adler Favorit 1 and 2, by Jörg Thien: Models 1 (1935) and 2 (1938) differ in their escapement and other details.

Also in this issue:

- *Odbners in Russia, Sweden, and the USSR*
- *Typewriters in Spain (ETCetera highlights)*
- *Dacometer adder*
- *Small mechanical accounting machines*

More information at [ifhb.de](http://ifhb.de)

## contact

No. 43, July 2012

- André Devaux obituary
- Meetings in Tours, Sins, and Partschins
- Breker auction

## HBw-Aktuell

August-September 2012

- Meetings in Pfäffikon and Vercelli
- Olivetti ephemera and giveaways
- Olympia Robust

October 2012

- International meeting in Wasselonne
- Meetings in Schnaittach and Wiedenbrück

November-December 2012

- Torpedo 30 with built-in watch
- Meetings in Braak, Markersdorf, Essen, Ludwigsburg, and Fairmont, West Virginia



Vol. 24 no. 4, November 2012

- The Baby Fox story
- Hemingway on typewriters
- Typewriter type improvements, 1917

## TALE OF THE CENTURY THE GREATEST TYPEWRITER NEVER MADE

It seems entirely appropriate to mark the 100<sup>th</sup> edition of *ETCetera* by writing about a typewriter called the Century. All the more so since the Century typewriter was planned to celebrate the turn of the 20<sup>th</sup> century—plans made by three of the greatest typewriter designers and engineers of the period.

It was an attempt to produce the “ultimate” standard typewriter—the “typewriter of the century,” it might have been dubbed. It was to be a typewriter so completely different, so radically advanced, that it would irrevocably change the course of typewriter history.

And to make this typewriter, the Century Machine Company of New York brought together a team of some of the finest typewriter minds of the age. It has always been the delicious thought of typewriter historians to imagine men like Burridge, Hess and Myers working together; in the case of the Century, this actually happened. The Century typewriter team comprised:

**Lee Spear Burridge:** Born in Paris, France, September 22, 1861. With Newman R. Marshman, Burridge designed the Sun index, then independently the Sun Standard and the first Underwood portable. His curriculum vitae is perhaps the most impressive among all typewriter inventors.



**Edward Bernard Hess:** Born Louisville, Kentucky, September 13, 1859. The man who, it was once claimed, held more than 140 typewriter patents. The



driving force behind the foundation of the Royal Typewriter Company, responsible for the Royal flatbed, Royal 10 and Royal portable.

**Lewis Cary**

**Myers:** Born Newburgh, New York, March 17, 1867.

After meeting and working with Hess on the Century typewriter project, Myers joined forces with Hess to found the Royal Typewriter Company. He was the technical expert capable of turning Hess's many fine ideas to reality.

**Joseph Martin Stoughton:** Born Albany, New York, August 9, 1856. Stoughton, like Myers, first worked with Hess on the Century project, and went on to work with Hess for the Mechanical Improvements Company and the early Royal designs and become the Royal Typewriter Company's first secretary. He was another man with vast practical experience in the industry.

**Frederick Vernon Jones:** Born Middlebush, New Jersey, December 16, 1857. Jones had worked as a “master mechanic” for the American and United Zylonite companies in North Adams, Massachusetts (the town was also known as Zylonite), designing ornately engraved cellulose nitrate combs, brushes and mirrors. Jones used this expertise to work with Myers in coming up with a process to make the typeslugs for the Century typewriter.

**Oluf Christian Tyberg:** Born in Copenhagen, Denmark, October 7, 1859. A naturalized mechanical engineer who designed stenography-style typewriters from 1891 until 1925. He established the Tyberg Typewriter Company and was later president of Theosophical University in San Diego.

There are eleven US patents covering the development of the Century typewriter, from its initial conception by Burridge in October 1896 through a flurry of activity in late 1899, as the team made a desperate but ultimately futile

effort to bring the project to fruition.

Burridge, Hess and Stoughton were involved from the start, and it seems likely they established the Century Machine Company. The concept began with a fairly straightforward-looking three-bank typebar typewriter with a semi-circular front. However, while it had 27

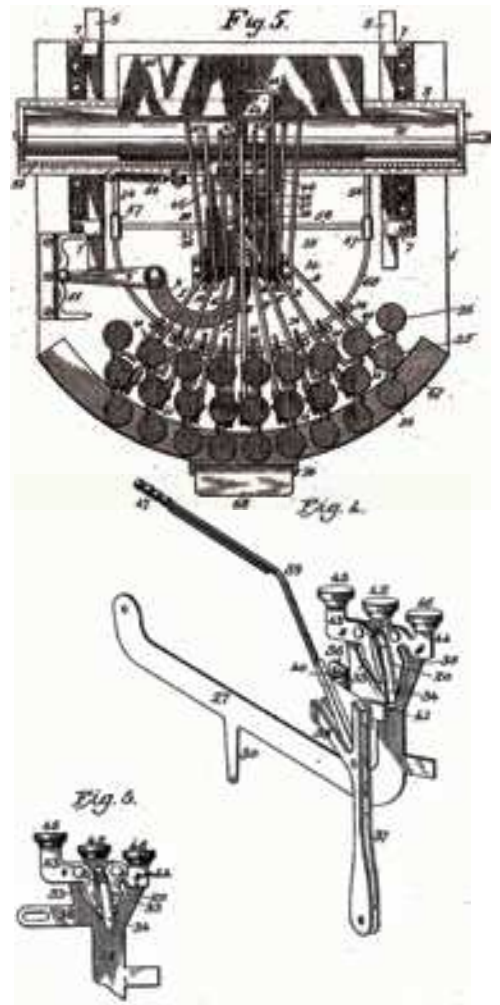

*Burridge's initial design*

keys, it had only nine typebars, and on each were nine typeslugs. It employed some of Burridge's customary ideas, of the key levers being operated by a rocking motion and an ink roller instead of a ribbon. Five months later Burridge carried the plan further.

No sooner had Burridge been issued with this second patent, in November 1897, than Hess and Stoughton took over the design work. Had Burridge gone too far? Was his thinking too radical for the

Century company? Hess and Stoughton's design was a little less ambitious. The nine typebars now had three typeslugs on each of three sides, and the shift key rotated the typesleeve on the end of the bars. The keys were thus independent of others on the keyboard. There was also a ribbon instead of an ink roller. (Rotating typebars were also employed on the Donnelly [Crown] in 1887.)

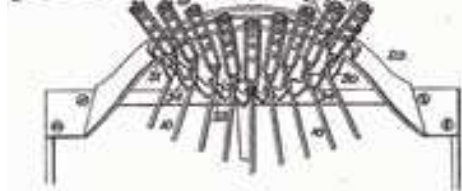
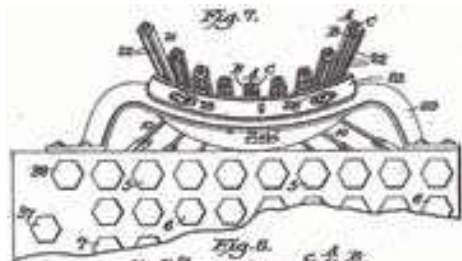
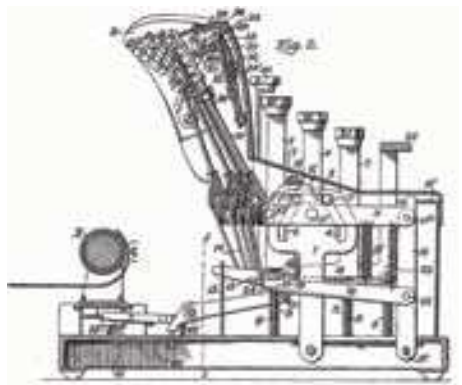

*Hess-Stoughton patents*

Hess and Stoughton worked on their concept for the next nine months, and in August 1898 applied for another patent. Meanwhile, Jones and Myers were brought in to add a key element: the typeslugs, and a means of making them using a matrix. Myers also designed the ribbon mechanism. At the same time, Hess collaborated with Stoughton and, separately, Tyberg to advance the linkage system and typing action.

These four patents, along with another one from Burridge, were all issued in the last five weeks of the 19<sup>th</sup> century, the Hess-Stoughton-Tyberg-Myers patents on November 21, 1899, and the Burridge patent a month later. Unlike the others, however, Burridge was still persisting with his original idea. He clearly did not believe the rotating typeslugs would work. Burridge's nine typebars



*Jones-Myers patent*

had nine typeslugs in a line on one surface, rather than three on each of three pivoting surfaces. An individual character was printed by both movement of the platen and movement of the typebasket. Burridge's machine had three shift keys, the Hess-Stoughton version two.

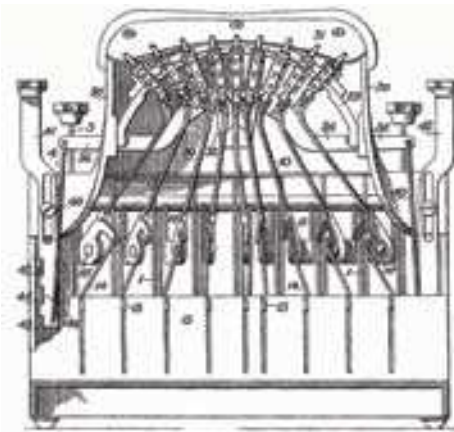
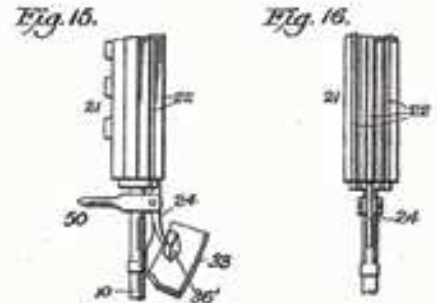
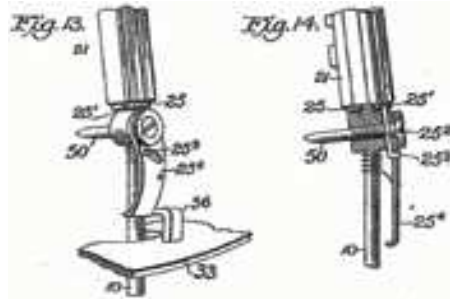

*Hess-Stoughton patents*

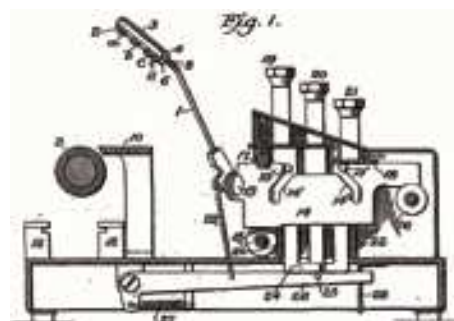

*Hess-Tyberg patent*

It's interesting that throughout the entire exercise, Hess, Stoughton and Tyberg consistently referenced Burridge's original Century patents, but Burridge only his own.

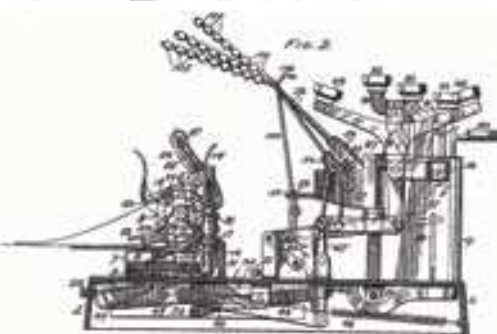
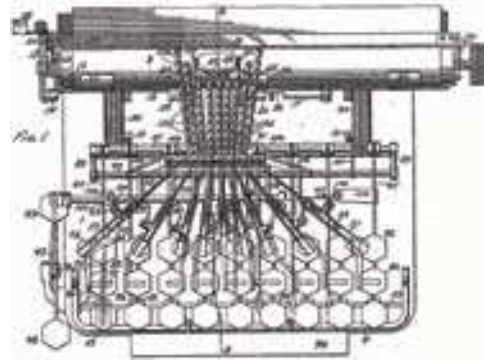

*Burridge's final effort*

Finally, on November 12, 1901, a patent applied for by Hess and Stoughton was issued, showing the Century in its full, never-to-be-fulfilled glory. The typebars had three typeslugs on the rotating typesleeves, but there were now ten typebars.

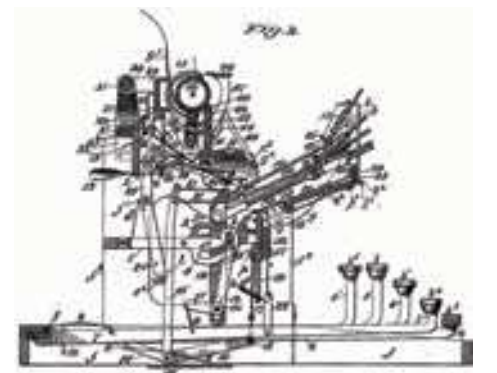

*Final Hess-Stoughton patent*

In 1909, George Carl Mares speculated on the Century in *The History of the Typewriter*, concentrating his comments on Burridge's original concept. Mares wrote, "the intention [was], by the use of suitable shifts and the depression of two or more keys, simultaneously, to permit of the writing of syllables and short words at a single strike." Mares, in a rare

## His Father's Fault?

by Eric Meary

Nobody has ever explained the reason for the hand of Myriam/Fatma (a sign of protection popular in both Islam and Judaism) on the early Dactyle. The frame of the Dactyle proclaims that engineer Octave



Rochefort was the sole licensee and constructor of the machine for France, Spain, Portugal, Belgium and Switzerland, based on the Blickensderfer patents (likewise for the Dactyle calculating machine). Very little is known about him except he was an engineer and lived from 1860 to 1950. In fact, he mostly appears on the Internet as the son of a major political character, Henri Rochefort. Henri Rochefort was a very important French figure of the second half of the 19th century; for political reasons he went to jail (and escaped), had nearly 20 duels, was director of a few caricatural and pamphletist newspapers, and wrote a few books and hundreds of articles. In his life he fought against Napoleon III (and much more), but more interesting for us, against the French Protectorate of Tunisia (a Muslim country) and Dreyfus. The Dreyfus affair was a political scandal that divided France in the 1890s and the early 1900s. It involved the conviction for treason (on behalf of Germany) in 1894 of Captain Alfred Dreyfus, a French artillery officer of Alsatian Jewish descent. This affair divided French politics in two: against Dreyfus were the right extremists, who were clearly antisemitic and among whom Rochefort was a leading personality, while the left progressive activists such as Zola and Victor Hugo defended Dreyfus. Just to show how important this historic fight is, after 130 years, if you type "affaire" on a French search engine, Dreyfus will be the first suggestion. I found very few things about Henri Rochefort's family except that his first son committed suicide in Algiers in 1889 and that he refused to see his daughter because her husband was pro-Dreyfus. I assume that a relationship with such a strong and extreme father (remembered today as the prince of press controversy) was difficult. So I finally decided that the Hamsa with the Star of David (a very well-known protection sign) is a proclamation: "I am not like my father." Eventually, all the accusations against Alfred Dreyfus were demonstrated to be baseless. In 1906, Dreyfus was exonerated and reinstated as a major in the French Army. He (and two sons) served during World War I, ending his service with the rank of Lieutenant Colonel.



fanciful moment, wryly added, "the writing—if it could be executed—was in full sight."

The remark "if it could be executed" implies the Century was never tested. This much we do know: the Century never went into production. Could that have been for no other reason than that Burrige and Hess, possessing two of the most fertile minds in typewriter history, simply could not agree? A ribbon or an inkpad? Rotating typeslugs or not? Whatever—Hess (according to Bruce Bliven, Jr. in *The Wonderful Writing Machine*) was later to dismiss it as a "freak form of visible" of which nothing came.

Michael Adler, in *Antique Typewriters*, also focuses on Burrige (a "characteristic" design, "typically ingenious") and says Hess and Stoughton "subsequently patented some improvements."

Mares covers the Hess-Stoughton work in a separate entry, while pointing to the Century. Mares says, "each typebar is equipped with a sleeve having three type-carrying faces." He explains, "when the sleeve shifting or rotating key is depressed, it becomes locked, avoiding the necessity of keeping the finger on the 'shift' key."

A Century typewriter did appear, in October 1919. It was a Century 10, made by the American Writing Machine Company at the Smith Premier factory in Syracuse. While this was the same American Writing Machine Company which had made the Caligraph and the New Century (Caligraph), it and Smith Premier were still operating under the umbrella of the Union Writing Machine Company. The Century 10 was a very conventional three-bank frontstrike, similar to the Remington Junior and apparently designed by Fred Sholes. ■

Next issue: *Oliver portables*.

My machine numbered 230 shares the aspects of early Blicks (decal, short inking system). According to Paul Robert, the early Blick ("D" for decal) goes to 5000, ending in 1894-1895. It seems early Dactyles had their own serial numbers. The rarity of the D Dactyle (2 or 3 as far as I know) and the existence of a lecture and an article about it in 1896 make me think that the D Dactyle starts at this period. Very soon, around s.n.

500, the new model arrived, with metal engraved name plate and modifications of the inking. Anyway, both are contemporary with the Dreyfus affair.

PS: Georg Sommeregger's Dactyle (#49) mixes features of a late machine (metal nameplate) and an early one (base and carriage). I have no idea if they took an unused old base, or if they restarted the Dactyle at 0. ■

*Above: decal from Dactyle #230 (Meary collection). Right: Dactyle #49, courtesy of Georg Sommeregger. More information at [http://typewriters.ch/collection/dactyle\\_typewriter.html](http://typewriters.ch/collection/dactyle_typewriter.html)*



# The Oliver

## WOODSTOCK

by Jett Morton

At first glance, it appears to be an Oliver No. 2. But you notice the odd side handles, and then you see the paper table's elegant decal—it reads WOODSTOCK. This machine has no correlation to the eponymous machines manufactured by the Woodstock Typewriter Company. This Woodstock was manufactured by the Oliver Typewriter Company in Woodstock, Illinois in 1898.

The Woodstock was discussed at meetings concerning the Detroit Board of Education's purchase of typewriters for high schools. This group of meetings, known as the Battle of Detroit, lasted from September 1898 to January 1899. A pamphlet published by the Linotype Company of Montreal, Canada covers these meetings in great detail.<sup>1</sup> According to the pamphlet, a certain Inspector Marr, presumably a member of the Board of Education, showed the committee formed to purchase typewriters an advertisement for the Woodstock in the Fall-Winter 1898-1899 Montgomery Ward catalogue, apparently in order to question the fairness of the price at which Oliver typewriters had been offered to the Board. W. A. Waterbury, the manager of the Oliver Typewriter Company, explained that the Woodstock was "an unguaranteed, cheap machine of which nineteen were all that were ever made." Waterbury stated, "We have a circular now in print for circulation offering \$5,000 for twenty Woodstock typewriters," reinforcing the fact that only nineteen were manufactured. He also stated that the Woodstock was manufactured strictly



for sale to large department stores, and all nineteen machines were sold to Montgomery Ward and Company, of Chicago. They contracted for the second grade machines which were not to be sold for under \$60. The Oliver Typewriter Company stopped manufacture of the Woodstock typewriter after it had been on the market for less than ten months. It is unknown how many machines Montgomery Ward sold.

No machines were known to have survived until recently when a Woodstock with a serial number of 1009, presumably the ninth machine produced, was listed on eBay. I was so astounded that such a rare machine existed that I had to bid on it, and I won!

After conversing with Bobbie, the eBay seller, I learned that this machine

made its way into a house owned by a self-proclaimed hoarder named Jim H. near Lancaster, California. He claims Jim does not know where he acquired most of his things, but he would shop at places such as flea markets, Goodwill, and auctions. The Woodstock came out of a house Jim owned for thirty years and never lived in; he used it just for storage. When Bobbie bought the machine, he placed it in his storage with initial intentions of selling it at his booth in an antique shop for \$40! However, he researched the machine first, and after finding no in-

formation on this Woodstock, he listed it on eBay, figuring it would bring a couple hundred dollars.



Anyway, the machine arrived safe and sound. After examining the machine in detail, I have concluded that the Woodstock is mechanically identical to early Oliver No. 2 machines.<sup>2</sup> The major dif-

2. There are several distinct styles of the Oliver No. 2 I can identify. The earliest style of Oliver No. 2 had round holes in the ribbon spool covers, the "Open O" logo on the side panels, a cutout in the base under the keyboard, a plastic key comb, curved metal springs for the spacing mechanism, a pivoting bearing for the shifting mechanism, and thinner keylever mounts. This style shows the 1894, 1895, and 1896 patent dates. I believe The "Open O" logo was introduced when the 1898 patent date was added. This is the style to which the Woodstock is most related. Later, the 1891 patent was listed on the machines. When this occurred, the second-to-last version of

1. The Linotype Company manufactured Oliver machines for Canada (including the Canadian Oliver No. 3) and South America.







ference between the Woodstock and the Oliver No. 2, aside from the Woodstock branding, is the base. The Woodstock base has altered side handles and, rather than curving inward, the back of the base mirrors the curves made by the front of the base. The base is currently painted

black, although it shows runs and has been touched up in a few places. Even the type guards have been painted black, some of which has chipped off, revealing a dark yellow color. The raised parts of the side panels are nickel plated, while the backgrounds are black.

In my opinion, the Woodstock does not appear to be a second-grade machine as W.A. Waterbury had described. I am hard-pressed to find a reason to render the Woodstock a cheaper Oliver No. 2 counterpart. The advertisement in the catalogue even stated that the Woodstock was “complete in a highly finished metal case with handle.” Unfortunately, such a case has yet to resurface. One can only hope a Woodstock in the original case may one day be discovered. ■

### Literature

*Battle of Detroit.* Pamphlet published by the Linotype Company of Montreal, Canada in 1899. Text available at: [http://archive.org/stream/cihm\\_10186/cihm\\_10186\\_djvu.txt](http://archive.org/stream/cihm_10186/cihm_10186_djvu.txt)  
Decker, Don. “Oddest Oliver.” *ETCetera* No. 4, July 1988.  
Sellers, Alexander “Sandy.” “The First Woodstock.” *ETCetera*

Oliver No. 2 was introduced. This style was given later-style ribbon spool covers with elongated holes, a solid base under the keyboard, a metal key comb, coil springs for the spacing mechanism (including other minor mechanical differences), a simpler wheel bearing for the shifting mechanism, and wider keylever mounts. The last variation simply added a model number on the paper table. I am still narrowing down between which serial numbers these variations were put into effect.



## New on the Shelf

Richard Amery: Erika 8 #1182185  
Lynda Beckler: mathematical Hammond Multiplex  
Lars Borrman: wide-carr. Remington Std. 8, Blick Featherweight  
Ned Brooks: Keystone (*photo p. 31*)  
Gabe Burbano: Courier, Dactyle, Oliver 15, Oliver 16, bakelite Oliver portable, Perkeo #57, Rofa, Sabb  
Gigi Clark: ABC, Bar-Lock 18, burgundy Barr Special #B4P1508, black Barr Universal #IBU273W, white Cole Steel, maroon Erika 5, Gossen Tippla, olive Groma Gromina, National 5, UK Oliver portable, mahogany Oliver portable 1 #3193Z, burgundy Optima Bambino, Porto-Rite (=Torpedo portable!) #9524, cream Remington portable 1 Deluxe, pink Remington portable 2, Royal Aristocrat w/ International Phonetic Keyboard, 2 Standard Foldings, Torpedo 18b, Torpedo 30  
Ken Coghlan: Avona, Blue Bird 18, Continental Silenta (with SS rune), Empire Aristocrat, Erika 5, Everest K3, Facit 1620 (script), Groma N, Hermes Ambassador, Ideal A4, Kappel Fips, Olympia Elite, Olympia Plana, Olympia Socialite, Optima Elite, Patria, Remington Portable 5, Rheinmetall Portable, Torpedo 20, Triumph Durabel, Triumph Perfekt  
David A. Davis: Remington 666  
Will Davis: Orga 10  
Don Feldman: New Century Caligraph 6, gold-plated Royal Quiet DeLuxe  
Thomas Fürtig: Corona sterling (gold & chrome plated), Gnomide (Reliable), Minerva 3, Oliver 20, silver-black marbled Olympia portable 1, Olympia Portable 1, silver-black marbeled Sun 2 with side-mounted ribbon, Yost 5  
Juan Ramón Gracia: Odell 1b, Pittsburg 10  
Joshua Hirsch: mother's Olivetti Lettera 32  
Jaap Horstink: Sténodactyle Lafaurie, Serie D, #53  
Flavio Mantelli: Briggs, Commercial Visible 5, Edison Mimeograph 2, Hammonia  
Eric Meary: Commercial 5 (*photo p. 31*)  
Robert Messenger: Adler 7, Antares Lisa 30, Bambino, British Empire, Corona Streamliner, Empire Aristocrat, Good Companion 1 & 7, Hall, Hammond Multiplex, electric Hermes Ambassador, Imperial Mead, Invicta (green), Montgomery Ward Escort 33, Oliver, Oliver 5, Optima Elite 3, Orel, Remington 2, Remington 7, Remington Home, Remington Rand 1, Remtor, Royal and Imperials Safaris and Sabres (5), Smith Premier 10  
Jett Morton: Oliver Stolzenberg, Woodstock (Oliver) #1009  
Frank Notten: Corona folding, green Imperial D, Junior, Mignon 4, Noiseless portable  
John Payton: Fox Visible, Simplex Little Giant, Star in orig. plastic bag  
Ettore Poccetti: Helios Klimax  
Richard Polt: Adler 32, Adler Special, Blick Ninety, Cyrillic Imperial Good Companion 7, Meteor (Spanish Patria w/ US keyboard)  
Marty Rice: 3 Underwood Deluxe Quiet Tabs (black & white, brown & beige, gray & bluegreen), Underwood Ace  
Javier Romano: Oliver 3, Salter 10, Yost 4  
Alan Seaver: white Escort 55 #8208670, Triumph 10 #100744  
Georg Sommeregger: Express (National port.) #1110, Japy 3Y #19378, French Rem-Blick #KS81423, Virotyp #9323, Yost 11 #99860  
Steve Stephens: Monarch Visible 2 #6719 (c.1905-1907), Remington 6 #3883 (1894), Royal KHM (1937), Royal Portable Standard (1931), Underwood 3 w/mystery lever on front (1909), Wagner Underwood 4 #12435-4 (1902), Smith Premier 10 (1911)  
Peter Weil: Toyriter (index, one of 3 known survivors)

# Is There an Esperanto Typewriter?

by Norbert Schwarz



Maybe you know Zamenhof as the inventor of Esperanto—but do you know Zamenhof as the inventor of a typewriter?

I was confronted with this question during a recent visit to Poland: are they two people who just share a name, or is it the same person? In brief: it's the same person!

## *The person*

Ludwig Lazarus Zamenhof was born Eliezer Levi Zamenhof, or in Polish, Ludwik Leizer Zamenhof; one also finds his name spelled Samenhof or Samenhoff when he is discussed in German. He was born on December 15, 1859, in Bialystok, which at the time was part of Russia, as the son of Jewish parents. While his mother was an orthodox believer, his father Mordechai was a rather atheistic teacher of German and French. Mordechai was fined 5000 rubles in 1888 on account of a magazine article, and lost his position as censor. His son paid the fine and consequently went bankrupt.

Esperanto was born in 1887 when Zamenhof published a book presenting the new language. The work appeared first in Russian, and then in Polish, German, French, and English. His attempt to create a universal artificial language can be attributed to the multicultural society of Bialystok at the time, where Russians, Poles, Jews, and Germans lived together more or less peacefully. Zamenhof, who had trained as an ophthalmologist, had to move frequently due to his bankruptcy, until he settled in 1890 in Warsaw, at 21 Nowolipki Street. There he also invented his typewriter, which received German Imperial Patent no. 95797.

## *Interlude: the Esperanto language*

So far, everything was clear to me: L. L. Zamenhof was bankrupt; as an ophthalmologist, he was intelligent, and obviously also technically gifted enough to invent a typewriter in order to escape from bankruptcy in this way.

But there is probably more to the story, and one must con-

sider the language itself. Esperanto is phonetic: every letter corresponds to a sound, and it is written with 28 letters. 22 of those letters are identical to English, but there are no q, w, x, or y. Then there are six characters with “little hats.” The complete alphabet, then, looks like this:

a b c ĉ d e f g ĝ h ĥ i j k l m n o p r s ŝ t u ŭ v z

The short vowel sign used over the U shows that the letter does not form its own syllable but is supposed to be pronounced as a half-vowel (like English W). For material written by hand, these signs were no problem, but not all typewriters of the time had such signs. The “little hats” were apparently introduced because at least the typewriters in use at the time with French keyboard were able to type them, using the circumflex accent on a dead key. (Some Slavic languages were also already familiar with a little hook or *hachek* over a letter, which looks like a little V.) In 1905, Zamenhof himself proposed the solution of adding an h instead of a “hat”—instead of ĝ one could write gh—and if necessary one could omit the short vowel sign over the ŭ. This is still the case today—so officially, there are two ways to spell Esperanto.

Now we can discern a completely different motivation for Zamenhof's invention: providing all the necessary signs on a typewriter, without using the rather cumbersome dead-key method.

## *The typewriter*

The German Imperial Patent Office granted “Dr. Lazarus Samenhof of Warsaw” a patent for a typewriter on December 16, 1891; the patent was published on November 29, 1892. “The present invention relates to typewriters of the kind in which the types are located under the ends of radial arms of a type disc ....”

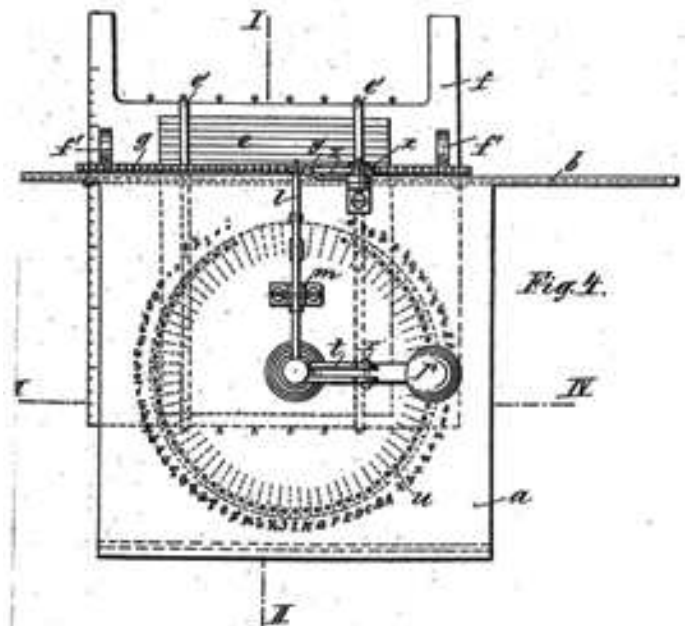

# An Appreciation of Richard Nelson Current

This rotating disc was divided into 80 segments which included, in alphabetical order, 26 lowercase letters, 26 uppercase letters, 10 numerals, and 7 punctuation marks. If you have been counting along, you have seen that 11 characters are missing; one of these must have served as an empty space. These characters are not assigned on the patent drawings. But we can infer that these arms were not simply meant to be left unused; they allowed room for more characters—for instance, the characters of Esperanto.

The paper lay on a plate that moved about 2mm to the left after every impression. The paper was secured by two rubber bands. It was moved to the next line by hand: the user would shift the entire plate all the way to the right, where markings would help one maintain the correct separation between lines. The inventor devoted little thought to inking: “The types may either perform their writing in the usual manner, by hitting a sheet of carbon paper placed over the writing paper, or they may be inked directly. To this end one can attach inked pads or rollers under the type disc, at either side of the opening *o*’; each type must pass over these devices before it reaches the printing position, so that inking of the type will occur.”

Now, is there a typewriter especially for Esperanto? Was Zamenhof’s typewriter ever built? There is no evidence that it was. But there really was an Esperanto typewriter: the Adler 7, which clearly was available with an Esperanto keyboard. “The Adler is the most perfect typewriter, especially for Esperanto. The Esperanto keyboard also permits writing in German, French, Italian, English, and Dutch,” says the text in Esperanto on this ad. No wonder: French and some Dutch loanwords from French use the circumflex.



Does anyone know this machine? It is probably not that easy to recognize, because one could easily mistake it for a typewriter with a French or Dutch keyboard. The dealer’s mark on the ad, indicating the Adler branch at Zimmerstrasse 92/93 in Berlin, may be a clear sign of a typewriter originally built for Esperanto. The probability of typewriters with such an Esperanto keyboard grows with the distance to countries which normally use these diacritical marks (e.g. France, Switzerland, Belgium, and the Netherlands). Probably there is no difference from the French keyboard at all, but the user’s manual may be helpful. ■

The *New York Times* obituary headline stood at the top of the page: “Richard N. Current, 100, Dies: Demythologized Lincoln” (*New York Times*, Sunday, Nov. 4, 2012). The account of this famous Lincoln scholar noted that “his first five books, written in the 1940s and early 1950s, included a history of the typewriter.” *The Typewriter and The Men Who Made It* (University of Illinois, 1954) is undoubtedly familiar to most *ETCetera*

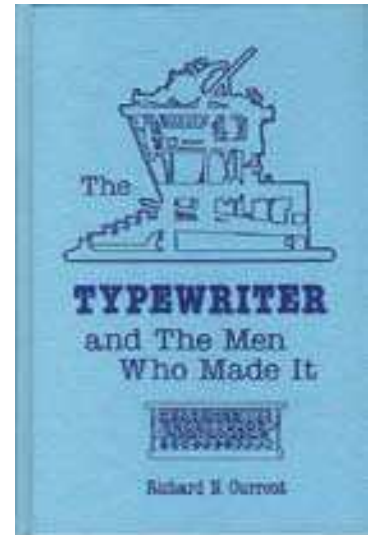

1988 Post-Era reprint

readers. It is appropriate that in the 100<sup>th</sup> issue of *ETCetera* we reflect on Richard Nelson Current, typewriter historian, who lived to be 100.

Regrettably, Current’s research interests turned away from typewriters. The scrupulous research behind *The Typewriter* is astounding. Part of his achievement came from the fact he had access to an important source of preserved material. He wrote, “Miss Priscilla Densmore...opened her family’s collection of Sholes-Densmore correspondence and gave me free access to it.” I too have found typewriter collectors who generously share their material and knowledge.

Nonetheless, I wonder about the fate of typewriter materials needed for research and writing in the future. Current was a scholar, not a collector. Collection and scholarship are two different fields. As a former archivist and museum curator, I have relied on collectors to help create publicly accessible research collections. As a historian and former university professor, I drew on both private and public collections.

Current was a tough critic, known to dismiss poor scholarship and writing with the observation, “What was new in it wasn’t true and what was true in it wasn’t new.” Perhaps we can honor the late Richard N. Current, typewriter historian, by working to create and keep intact—perhaps electronically, if not physically—the research resources needed by future typewriter historians. Let us keep making typewriter history both accurate and new.

Norman R. Ball  
Historian of engineering and design  
nrball@istar.ca

# The “Small Office Typewriter” from Brother

by Will Davis & David A. Davis

*We would like to dedicate this article to our late father David B. Davis, an active and avid typewriter collector and researcher. This is exactly the kind of thing he enjoyed discovering, and he would have been very happy to have had an article in this landmark 100<sup>th</sup> issue.*



1966 wide-carriage Brother De Luxe 905

The recent increase of typewriter collectors who consider themselves members of the “Typosphere,” that is to say, those who type their material and then scan the typewritten copy for blog posting, has led to an increased interest in using mechanical typewriters. For these people, and for those who desire a competent machine for generating typewritten copy, functionality is of the utmost importance. Some machines which fit this bill are often ignored. One of these machines is the rather short-lived, large “desk model” portable offered by Brother, known internally to Brother as the “JP-3” series.

According to Wilfred Beeching’s *Century of the Typewriter*, Brother first investigated entry into the manufacture of portable typewriters about 1954. The company deferred, wishing to further evaluate designs and develop a high quality product. Brother was eventually spurred into pro-

ducing typewriters by Western Auto, with whom Brother was already doing a fair business in domestic sewing machines (this according to FTC documents.) The launch of this first Brother typewriter occurred in 1961, and it was designated internally as the JP-1. This machine is the Brother typewriter with which many should be familiar, as it is by far the most common model seen. This carriage-shifted compact machine appeared in a wide variety of body shapes, styles, sizes and colors over the years, to say nothing of the wide variety of brand names. In fact, the JP-1 is very likely the *most* re-branded typewriter of all time. (As an aside, if one examines a mechanical typewriter made in Japan and has no idea who made it, if the sticker or label on the rear says “Made in Nagoya, Japan” the machine is certain to be a Brother, and not a Nakajima, Silver-Seiko, Nippo or Konryu.)

Within a few years, Brother’s engineers had developed what are today a relatively unknown pair of designs—the JP-2 electric type-bar “small office” machine, and the companion fully mechanical JP-3. The two machines made their first appearances in US trade in the middle 1960s, the JP-3 manual machine appearing in Montgomery Ward’s catalogs around 1966, while according to Beeching the electric JP-3 model appeared “about 1968.” (Patents for the electric model were filed worldwide in 1966-1967.) The machines share common carriages, with identical parts. The ribbon selector device, an instantly recognizable three-button design located to the right of the keyboard, is also common to both machines.

While the JP-2 sold only in very small numbers (apparently most of these were actually sold as the Sperry Remington 700) the JP-3 had a much wider sale through Montgomery Ward initially, and later through other channels in the US carrying the Brother name.

The JP-3 is a somewhat large sized desk-model machine with 44 keys, segment shift, and fully parallel key action. The machine is fitted with an effective key tension regulator, and the aforementioned characteristic ribbon selector is extremely convenient. The machine’s operation is not among the qui-



1971 Signature 510D

etest, but the parallel key action and range of touch make the machine satisfactory for even novice typists. More expensive variants included wider carriages and paper-wind or feed levers, like those on office typewriters of the day. On a stable desk, the JP-3 is a rugged typewriter that can stand hard use and abuse. We have tested literally hundreds of makes and models here, and we feel that the JP-3 series should be seriously considered by actual typists. While the merits of the machine may not immediately be apparent to those familiar with other makes, the machine comes fully into its own with continued use. In fact, this machine is a far better typewriter than many contemporary machines that originally cost quite a bit more.

## Montgomery Ward model delineation

Since most of the examples of the JP-3 to be found today carry the branding of Montgomery Ward department stores, under their “Signature” brand, it is valuable to this study to briefly delineate the various modifications to the JP-3 in fit and first cost relative to their M-W model numbering and identification.

When introduced in 1966, the line offered three variants of the JP-3, which Ward’s sold as the Signature 088, the Signature 510 and the Signature 513. The price for the basic 088 model was \$78.88. The 510 model added an erasure table, plastic paper scale, and paper winder lever, together referred to as the “Simplified Paper Handling



1966 Montgomery Ward ad

System.” This 510 was sold for \$88.88. The 513, at \$98.88, had a 13-inch carriage with a 12.5-inch writing line whereas the other two had 10-inch carriages with a 9.5-inch writing line. At this early date, none of the models had paper bails. These were added later to various models. All models had key-set tabulators. Later variants were merely modifications of these basic types. Brother also sold this machine through other avenues as the Brother DeLuxe 900 and 905, Echelon 91, Opus 900, and other names and numbers.

An interesting variant in this line which appeared somewhat later was the Signature 510D. This machine was unique because it had been modified to incorporate Brother’s patented “Dial-A-Type” replaceable type head on the rightmost type bar. Since this device was larger than a conventional type slug, the machine had a modified segment with the rightmost typebar spaced far apart from the next adjacent one. On the 510D, a wide space is thus left unmachined and easily visible in the segment. A red key top on the +/- key lever indicated this feature.



(The smaller JP-1 series machines when fitted for Dial-A-Type installation simply have no room for such modification, so they omit one type bar and one key and also have an empty slot in their typebar segments. These are quite uncommon.)

A later addition to the JP-3 series machines was the Signature 511, which was the same machine essentially as all those earlier but which was contained in a very new style of body. The 511D model added a rapid spacer feature. This body, stylistically, is comparable to the Royal Sabre line.

It would appear that the JP-3 machines were in production approximately eight years and possibly less. The final Brother portable typewriter design, well known with segment shift, low profile, and key lever mounting on four separate dowels, may



*Signature 511*

have in fact been the cost revision to the JP-3 to bring profit back to the line. (The JP-2 electric did not fare even as well.)

*A connection to a more famous machine?*

Years back in 2004, while researching the Barr Typewriter for an article on my (Will’s) website, the following story came to light by way of Don Hoke: It is said that after Barr shut down, someone named Fisher (who owned a typewriter repair shop in lower Manhattan) bought the tooling, machinery and patents for the Barr and redesigned it. According to the legend, Mr. Fisher enlisted the help of Peter Tytell to redesign the machine, which would then have been re-launched as the “Fisher.” It never was, but a contingent of Japanese on an investigative mission in the U.S.A. is known to have looked at the design. These investigators from Brother were nearly ready to buy it at one point but ended up deciding not to. Later, a very similar Brother machine appeared on the market, which according to legend attracted the attention of the previous “Fisher/Tytell” group. No suits were filed but the legend says it was considered. At the time during this research on the Barr I contacted the Tytells to ask about this legend, but received no response.

One would have to imagine that the machine in question in this story was the Brother JP-3, and not the JP-1. The JP-3 has parallel key action like the Barr, and is segment shifted. One could imagine engineers fairly schooled in the art seeing a Barr, or something like it, and coming up with the JP-3 even if they had no actual mechanical drawings. Again, this story is legend, but the design parallels are there! Apparently Hoke’s notes exist at the Milwaukee Public Museum, but the last time I called they were not available for review.

In summary, this is a very interesting machine. Why did Brother introduce a

completely new manual portable machine at this late date? Why enter into a highly contested market when the future of typewriters seemed to be turning towards the electric? Why not just soldier on with the already well established JP-1 design? Is this new machine essentially the redesigned Barr, at least in form and concept? Did the investigative mission by Brother convince them that such a machine was far superior to their JP-1? No matter these fascinating questions, the machines we are left with today are fine typewriters for regular use. As such, and especially because of their murky evolution, they are worthy of consideration by collectors and users alike. ■

**GARBELL**  
THE  
NON FOLDING  
NON COLLAPSIBLE  
SMOOTH RUNNING  
PORTABLE



COMPACT AS A WATCH



THE NEW, IMPROVED, HELMSTROM  
INTERCHANGEABLE CARTRIDGE

The “GARBELL” is a typewriter of improved construction. Easiest to operate, the most economical to maintain. Demands for portable typewriters far surpasses past market, and with the many added features to the “GARBELL” the most compact traveling machine brings it to the top of the portable market. For further particulars write.

**Garbell Typewriter Co., Inc.**  
*Factory and General Offices*  
1812-14 Elm St., Chicago, Ill., U. S. A.

From *Typewriter Topics*, November 1919. I have recently gotten digital copies of *Typewriter Topics* for 1907, 1909-1912, 1915-1920, and 1922. Contact me at polt@xavier.edu if you want them. —Ed.

# Letters and More

I want to congratulate you for another *fantastic* issue: I have always been very curious about the Halda prototype machines pictured in Wilf Beeching's book and have finally seen better pictures, a description and a good story on the factory. Great job!

I was also pleased to learn that the Oliver can be considered a portable machine.

Flavio Mantelli  
Milan

Regarding Dr. Weil's excellent article in your most excellent magazine: the child in the photo in the far right hand column on page 9 is not a girl. It is a boy in a "Little Lord Fauntleroy" suit. These were very popular in the 1890s, and in fact I have a picture of some obscure relative wearing nearly the same garment but on a dark basic suit. Note that he is wearing breeches, not a skirt, and study the features and hairline—decidedly masculine. Dr. Weil's remarks on the status of girls and women are apt, but this here ain't one.

Gary Roberts  
South Bend, Wash.



*Peter Weil replies: I very much appreciate Gary's suggestion and his generous praise for my article and for ETCetera. Certainly, many portraits were made of boys wearing girl's clothing or Little Lord Fauntleroy suits. But I have never seen any boys featured as typewriter users in a Smith Premier ad. The use of little girls in Smith Premier advertising begins with the model 1, as in this ca.*



*1893 trade card. The little girl as typist becomes common beginning in 1896, with the introduction of the #2 and #4. This is most elaborately presented in their booklet "Our Juvenile Class."*



This incredible candy toy container (1&7/8" square by 1" high) was made and filled by the Sell-Best Novelty and Candy Co., Inc., of Brooklyn, New York. On the bottom of the box is printed "CANDY" and "TOY." The company appears to go back to the beginning of the 20th century, and the form of this box is an office machine from, I would guess, no later than about 1925. I am sure it was bought for no more than a penny, and

for the toy at least as much for the candy (whatever either was). It might even have shown up in Christmas stockings. Given the strong gender bias of the times and their link to typewriters, it may have been thought of as a "girls" item.

Peter Weil  
Newark, Del.

A few corrections to the Typit article: my apprenticeship was from 1951 to 1954, and the Typit box contains 36 units; the sixth compartment is probably just for display or packaging. Can anyone provide further information about the American inventor of the Typit, Robert Twyford, and his company, "Typit Division," based in Alexandria, USA?

Klaus Brandt  
Am Böhmerwald 22  
22851 Norderstedt, Germany  
klaus.brandt@wt.net.de

I am enjoying issue no. 99 very much. Especially the "Typit" article. What an interesting development.

I am attaching a picture of my "work horse" machine—a Smith-Corona Galaxie 12 that I got from eBay. This is a very solid machine, and I use it to type all my poems on. My son, Nigel, loves to "play" with it, especially the "power space" button. It's all great until he decides to pull out the ribbon. I found the old typing table in my attic. I did it in an apple green. It makes a great little work space in my bedroom.

Thank you for a wonderful magazine.

Jennifer LaVoie  
Fall River, Mass.



I was rather excited when an Olympia Elite popped up on Craig's List a few months back for a great price. I emailed the seller immediately and set up a meeting. As I am always a bit wary of Craig's List, I was relieved when the seller gave me the address of his workplace, along with the hours they would be there. When I arrived in Central New Jersey, however, I found that it was a retirement home; the hours given were visiting hours.

After the receptionist took my name and the name of the resident, he called the appropriate room but there was no answer, I eventually found the seller, Keith, along with his wife, in the cafeteria. He waved me over and I sat down. At this point, I was absolutely touched. Not only were they an adorable older couple (near 80, I would guess), but they had gotten me lunch.

Over the next half hour or so, we talked like old friends. I felt so welcome eating and drinking with these near strangers; one of the most heartwarming experiences I have had. At the end of it all, it was no longer about the typewriter, but the amazing connection I shared with a few great people. People I would not have met, were it not for my love of writing machines.

-Sent from my Olympia Elite

Ken Coghlan  
Oxford, Pa.

I've collected 56 Spanish patents for typewriters made in Spain, foreign typewriters (but written in Spanish), and typewriter accessories. I'd like to share this information with *ETCetera's* readers. You can download a Zip file (72.5 MB) containing the patents at:  
[dl.dropbox.com/u/11057248/Patentes.zip](http://dl.dropbox.com/u/11057248/Patentes.zip)

Fransu Marín  
Urnieta, Spain



An everyday Remington portable no. 3? No, it's a Remington Z portable, made by Zbrojovka Brno in Czechoslovakia, from the collection of Štěpán Kučera.



Eric Meary's Commercial no. 5 (not labeled "Visible")



Remington Portable "Kwiksale" display case, new to Peter Weil's collection



Incomplete, but can't be beat: Ned Brooks' Keystone cost only \$45, proving that there are still typewriter bargains to be found.



Klaus Brandt shows us this interesting selection of Olympia keys with special characters—including the Volkswagen logo!

You can look back on your work with pride: 100 issues of *ETCetera* are a really impressive number for an international collector's magazine. We, the Internationales Forum Historische Bürowelt, would like to congratulate you and your readers cordially! Since 2006 you have been responsible for editing the magazine with impressive results and growing success. You have left your mark on the magazine: a publication of the highest level, full of multifaceted articles ranging from well-grounded typewriter history to amusing extras to souped-up portables and tips on relevant blogs—to name just a few examples. On this occasion we would also like to thank you for your always good collaboration with the IFHB, and we wish your successor, Alan Seaver, all the best for his future work.

The IFHB Board of Directors:  
Wolfgang Mock, President  
Harald Schmid  
Norbert Schwarz  
Georg Sommeregger

Thank you! It's good to have international contacts and collaboration. My predecessors as editors and all the outstanding contributors to *ETCetera* also deserve my thanks.



At the October 13 meeting at Herman Price's home, Peter Weil presents me with a cake in the shape of a Sphinx typewriter and the QWERTY award: Quality Work with Excellence in Reporting on Typewriters, Year 2012. Thank you, Herman and Peter!





This back issue of

# ETCetera

is brought to you by

The Early Typewriter Collectors' Association



The mission of the Early Typewriter Collectors' Association is to support communication and interaction within the community of typewriter lovers and collectors, and to encourage its growth. Our magazine, *ETCetera*, serves that mission by gathering and sharing knowledge about typewriter history with the community and beyond.

Learn more at

[etconline.org](http://etconline.org)