



Land Launch User's Guide

Revision: B
Date: 01.10.2014

Contents

Abbreviations and acronyms

Introduction

- Purpose

- Overview

- Land Launch system structure

- Baikonur

- Advantages to Customers

- Mission integration

- Land Launch organizational structure and Land Launch partners

 - Space International Services

 - Center for Ground Space Infrastructure Operations

 - Yuzhnoye State Design Office

 - Yuzhny Machine Building Plant

 - RSC Energia

 - S.A. Lavochkin Research and Development Association

 - RUAG Space Sweden

 - Russian Federal Space Agency

 - Governmental Space Agency of Ukraine

Description of Zenit-2SLB, Zenit-3SLB, Zenit-3SLB integrated launch vehicles

- Zenit-2SLB integrated launch vehicle

 - Zenit-2SB launch vehicle description

 - Zenit-2SLB ascent unit

- Zenit-3SLB integrated launch vehicle

 - Zenit-3SLB ascent unit

- Zenit-3SLBF integrated launch vehicle

 - Zenit-3SLBF ascent unit

Land Launch system performance

- Basic provisions

- Zenit-2SLB payload capabilities

 - Zenit-2SLB generic ascent trajectory

 - Zenit-2SLB separation conditions and injection accuracy

- Zenit-3SLB and Zenit-3SLBF payload capabilities

 - Zenit-3SLB and Zenit-3SLBF generic ascent trajectory

 - Zenit-3SLB and Zenit-3SLBF separation conditions and injection accuracy

Interfaces

- Mechanical interfaces

 - Payload envelope under fairing

 - Access hatches

 - Customer logo

 - SC adapter

- Electrical and radio frequency interfaces

 - SC-to-GSE hard-line link

 - In-flight commands, measurement and telemetry

- Electrical GSE links
- Electrical power for GSE
- Static electricity protection, lightning protection
- RF links, radio transparent window

Spacecraft environments

SC structural loads

- Quasi-static loads during transportation and processing
- Quasi-static loads during lift-off and in-flight
- Sine vibrations in-flight
- SC dynamic model
- Random vibration during SC and GSE transportation
- SC random vibration during lift-off and in-flight
- Shock

- Acoustics during lift-off and in-flight

- Electromagnetic environment

- Thermal and humidity environments

 - Ground thermal and humidity environment

 - Thermal environments in-flight

- SC thermal model

- Pressure venting

- Contamination

Land Launch facilities

ABBREVIATIONS AND ACRONYMS

AU	Ascent Unit
AUPF	Ascent Unit Processing Facility
CBOD	Clamp Band Opening Device
CCAM	Contamination and Collision Avoidance Maneuver
CLA	Coupled Loads Analysis
CS	Control System
EDC	Effective Date of Contract
EMC	Electromagnetic Compatibility
FEM	Finite Element Model
FSA	Russian Federal Space Agency (also Roscosmos)
GEO	GEostationary Orbit
GSAU	Governmental Space Agency of Ukraine
GSE	Ground Support Equipment
GTO	GeoTransfer Orbit
HPF	Hazardous Processing Facility
HPTS	High Pressure Temperature control System
ICD	Interface Control Document
ILV	Integrated Launch Vehicle
IRD	Interface Requirements Document
JTB	Jettisoned Tanks Block
LC	Launch Complex
LLUG	Land Launch User's Guide
LNPO	S.A. Lavochkin Research and Development Association
LPTS	Low Pressure Temperature control System
LSP	Launch Service Provider
LV	Launch Vehicle
ME	Main Engine
PIMA	Payload Integration and Mission Analysis
PPF	Payload Processing Facility
RF	Radio Frequency
Roscosmos	Russian Federal Space Agency (also FSA)
RSCE	S.P. Korolev Rocket Space Corporation Energia
RUAG	RUAG Space Sweden
SC	Spacecraft
SCA	Spacecraft Adapter
SIS	Space International Services
SRB	Solid Rocket Booster
TC	Transfer Compartment
TMI	Telemetry Information
TsENKI	Center for Ground Space Infrastructure Operations
YMZ	Yuzhny Machine-Building Plant (also Yuzhmash)
YSDO	Yuzhnoye State Design Office
Yuzhmash	Yuzhny Machine-Building Plant (also YMZ)

INTRODUCTION

Purpose

The purpose of the Land Launch User's Guide (LLUG) is to familiarize members of the launch services Customer community with the services provided by Launch Service Provider (LSP), Space International Services, Ltd (SIS) using Zenit-M Space Rocket System at Baikonur launch site.

LSP offers three integrated launch vehicle (ILV) configurations (see figure below) to support launches of the widest range of various type and purpose satellites: two-stage vehicle with no upper stage - Zenit-2SLB, three-stage vehicle including Block DM upper stage - Zenit-3SLB, and three-stage vehicle including Fregat-SB upper stage - Zenit-3SLBF. Hereafter, ILV refers to any of these configurations unless otherwise stated.



Figure. Three configurations of the Zenit family vehicles (left to right):
Zenit-2SLB, Zenit-3SLB, Zenit-3SLBF

The User's Guide is intended to provide the initial scope of Land Launch technical data, capabilities, data for planning, integration and launch operations sufficient for a potential Customer to make its own compatibility assessments of the Land Launch system elements and Customer's spacecraft (SC). For more information and to initiate preliminary studies of Land Launch system compatibility with a spacecraft it is recommended to contact LSP directly at sis@landlaunch.ru.

Overview

Zenit launch vehicle (LV) heritage goes back to 1985 and has a record of more than 80 launches (as of 01 January 2014). Besides that, eight Zenit first stages were used as boosters on two launches under Energia-Buran program.

One of the intended purposes of original Zenit vehicle was manned launches. Therefore, in the course of its design and development a special attention has been paid to reliability. Besides that, the LV design encompasses significant internal margins and back-ups, ease of operations and quick launch processing capability based on highly automated prelaunch operations. The LV design was based on effective and non-toxic propellants - oxygen and kerosene, and employment of the most powerful liquid propellant engine in the world with thrust of 740 tf. Besides the features above, all Land Launch vehicles are using high-accurate inertial digital control system.

The Zenit space rocket system being the basis for the Land Launch system has been developed as a fully automated complex not requiring presence of any personnel whenever the launch vehicle is being processed on the launch pad. This allows controlling and managing prelaunch processes distantly from the command post (bunker).

Starting from 2002, Zenit space rocket system modernization efforts were being performed under Land Launch program. The upgraded Zenit space rocket system was called Zenit-M space rocket system, also referred to as Land Launch system. The modernization was done for the purpose of enhancing system's capabilities and its commercialization for launches of non-military spacecrafts. The main feature of modernization was introduction of the third stage, upper stage in the structure of the ILV as well as significant ground infrastructure upgrades using modern state-of-the-art technology.

Also, the original two-stage Zenit launch vehicle was upgraded, now it is called Zenit-2SB. The upgraded launch vehicle design absorbed experience gained previously under Sea Launch program.

The Zenit space rocket system modernization has been legally based on the Russian Government decree. These activities were coordinated and supervised by the Russian Federal Space Agency (FSA). Space International Services was selected to act as the customer and lead finance and investing company for this modernization activity. Afterwards, upon completion of this job SIS was granted exclusive commercial rights for Land Launch system operation.

Upon completion of Land Launch system modernization the system was certified with a successful launch of upgraded two-stage launch vehicle in 2007. The first Land Launch three-stage ILV, Zenit-3SLB with Block DM-SLB upper stage took place on 28 April 2008.

Further second step modernization activities initiated by FSA (also known as Roscosmos) were completed in 2010. Now the system includes Zenit-3SLBF integrated launch vehicle with Fregat-SB upper stage. The first Zenit-3SLBF launch carrying a Russian federal payload took place on 20 January 2011.

Land Launch system structure

The system includes:

- Zenit-2SLB two-stage integrated launch vehicle,
 - Zenit-3SLB three-stage integrated launch vehicle,
 - Zenit-3SLBF three-stage integrated launch vehicle,
 - Zenit-TM LV and ILV processing facility,
 - Zenit-SM launch complex (LC),
 - Zenit-2SB launch vehicle transportation equipment set,
- also, the system includes functionally involved ground space infrastructure facilities and equipment:
- Upper stage processing facility, payload processing facility (PPF) and ascent unit processing facility (AUPF),
 - Upper stage transportation equipment set, fairing transportation equipment sets for various types of Land Launch fairings, AU transportation equipment set, SC and associated ground support equipment (GSE) transportation kits,
 - Hazardous processing facility (HPF) for upper stages and spacecrafts,
 - Ground tracking and telemetry systems,
 - Approved downrange stage and fairing impact zones.

Baikonur

The Land Launch launching facility, Zenit-SM LC is located at Baikonur cosmodrome territory in Kazakhstan at 63°E, 46°N. During Soviet times, Baikonur was the basic launch site for space missions, and still is one the world's main site for space launches.

Many important space era events are related to Baikonur. From here, the first artificial satellite, sputnik was launched in 1957, the first moon probe in 1959, and first manned launch in 1961. In recent years, Baikonur became significantly important as a commercial-purpose launch site.

Baikonur is connected with major cities of Russia, Ukraine and Kazakhstan via air, motorways and railroads. The launch site itself also has a well-developed railway net and highway system. Main spacecraft processing facilities are situated 60 km away from Baikonur city. Baikonur city is located on the north bank of Syr-Darya river. Tyuratam village is located adjacent to Baikonur city hosting a Kazakh rail station with the same name. Krayny airfield provides regular passenger and charter flights with Moscow supporting landing and

accommodation of the most types of passenger and cargo aircrafts. SC and other cargoes delivery is provided via Yubileyny airfield located on the cosmodrome territory.

The Land Launch system is one of the latest launch systems at Baikonur. First launch was in 1985. The system is located away from inhabited areas making third parties safety assurance easier. More details on the Land Launch system facilities (see figure below) and their purpose are given in the Launch site ground infrastructure section.

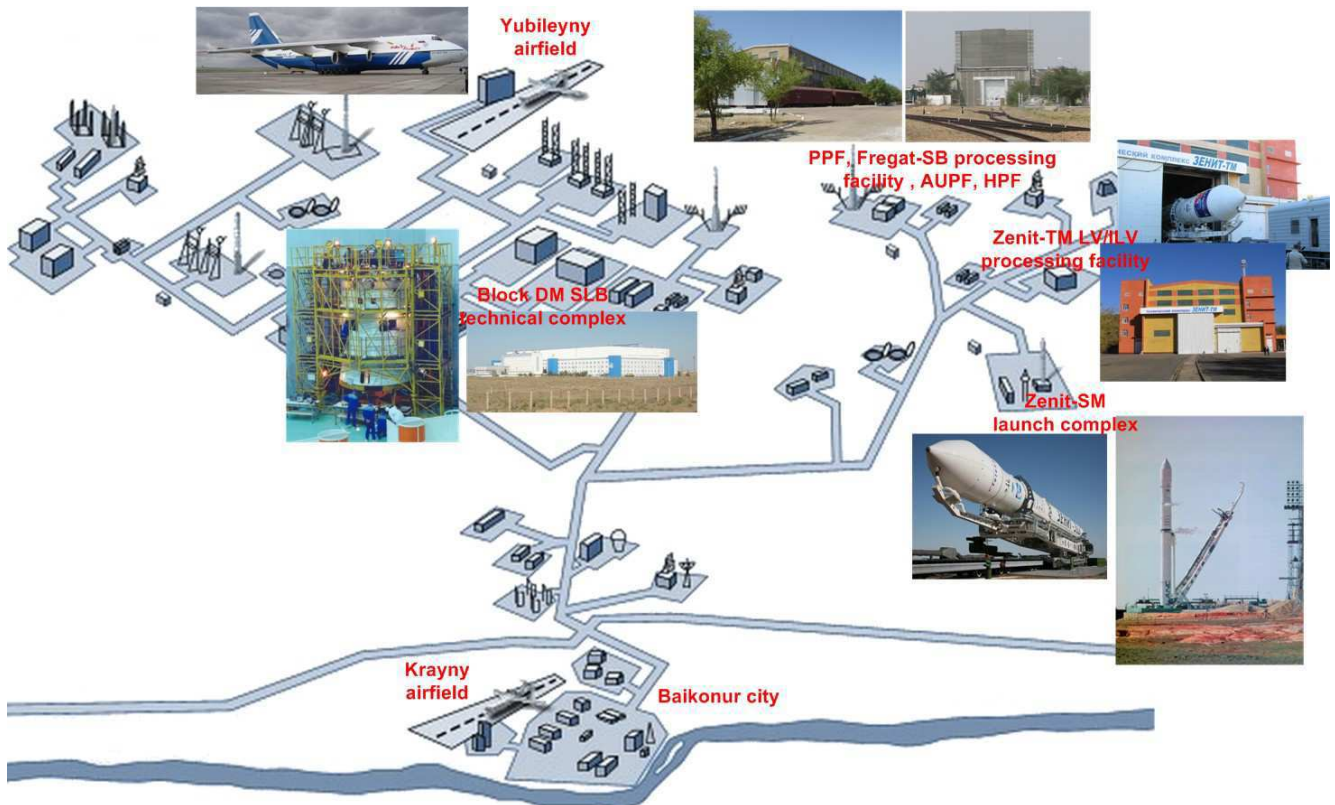

Figure. Layout of the cosmodrome and facilities involved in the Land Launch program

Advantages to Customers

The Land Launch partners are the world's leading space industry companies. Their count is a large number of systems, units and devices developed in support of launches and operations of many space articles, manned missions, space stations, integrated launch vehicles, automatic launch complexes and test and processing facilities.

The main advantages are:

- Reliable proven flight hardware used for numerous launches,
- Reliable ground support facilities that supported more than 500 missions,
- Dedicated launch for a single spacecraft eliminating schedule and

technical risks associated with co-passengers. However, cluster launches are feasible on Customer's demand in support of orbital constellation deployment,

- Wide range of payload masses at the expense of ILV configuration variety,
- Wide range of target orbits including geostationary, transfer, low earth orbits and escape trajectories,
- Launch mission shortened durations,
- Flight design flexibility supporting spacecraft attitude requirements during coast maneuvering,
- The teamwork and proven expertise of partners and subcontractors on Land Launch and other programs,
- Land Launch program is supported by national space agencies of Russia and Ukraine.

Mission integration

The typical integration timeline for a new type of spacecraft is 18 months after effective date of a contract. For a spacecraft type previously flown on Land Launch the integration may be done within a lesser time. Integration timeline may be affected by such factors as hardware availability, sufficiency and completeness of SC input data. After execution a launch services agreement, the LSP compiles and agrees upon the Integration Plan and Schedule with a Customer. The Plan and Schedule includes all steps and terms of the mission integration process. The top-level standard mission integration schedule is shown on figure below.

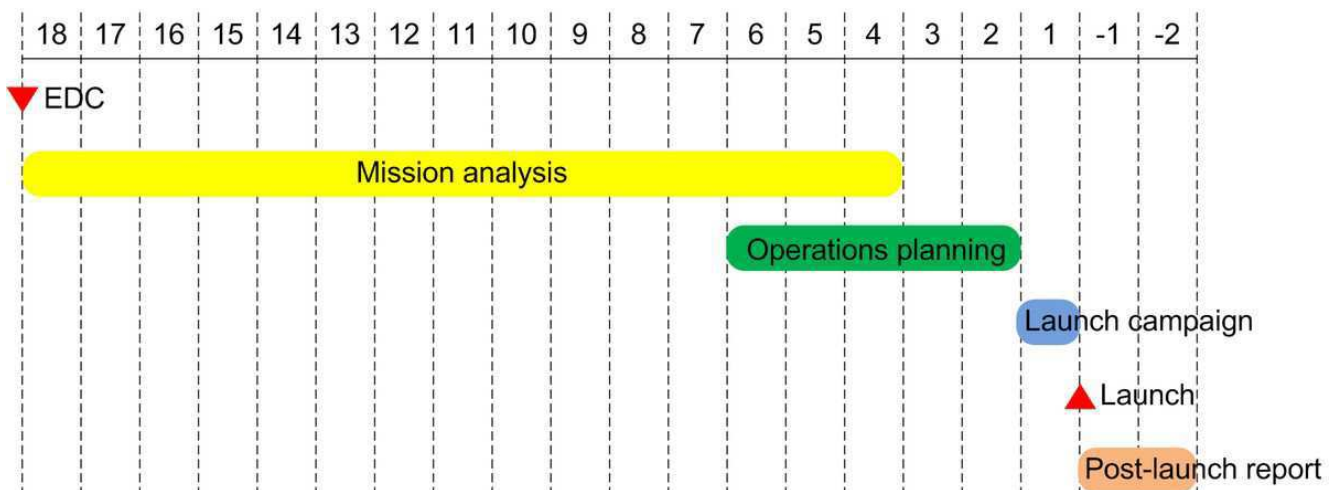

Figure. Standard mission integration schedule

The LSP is dedicated to flexibility in satisfying Customer's needs. Deviations from the standard flow requested and approved by a Customer are possible. These will be accommodated on a case-by-case basis, as required.

At start of work, the LSP assigns a single point of contact (Mission Manager) to interface with a Customer and Land Launch partners. The Mission Manager coordinates all integration and mission activities including technical, contractual issues, licensing and permits. The Mission Manager provides Progress Reports including analytical integration, flight hardware production and other issues critical for mission success.

The Land Launch program provides full scope of Customer mission activities starting from pre-contract meetings and all the way to the post-flight reporting. These activities include but not limited to:

- Dedicated launch as well as cluster launch capabilities,
- Program management,
- Mission management,
- Configuration management,
- Flight hardware production,
- GSE manufacturing and upgrade for Customer's specific requirements,
- SC test support including load tests and matchmate tests, if required,
- Flight hardware and support equipment mechanical and electrical interfaces mating support,
- Launch site facilities operations support,
- SC and GSE transportation within the launch site,
- Associated auxiliary services,
- Mission flight design,
- Flight task simulation for Customer's specific needs,
- Electromagnetic compatibility (EMC) support,
- Communication and telemetry during launch,
- Safety and security,
- SC propellant delivery and return of its residuals,
- SC, GSE and propellant shipment customs support.

For initial assessments of SC compatibility with Land Launch Customers are encouraged to provide LSP with SC input data as User's Questionnaire (Appendix A), Interface Requirements Document (IRD) or in any other convenient form.

Land Launch organizational structure and Land Launch partners

The Land Launch launch services at Baikonur are provided under contract by Space International Services (LSP). The major program partners are the leading space industry companies of Russia and Ukraine. The organizational diagram and description of the partners involved in the Land Launch program are given below.

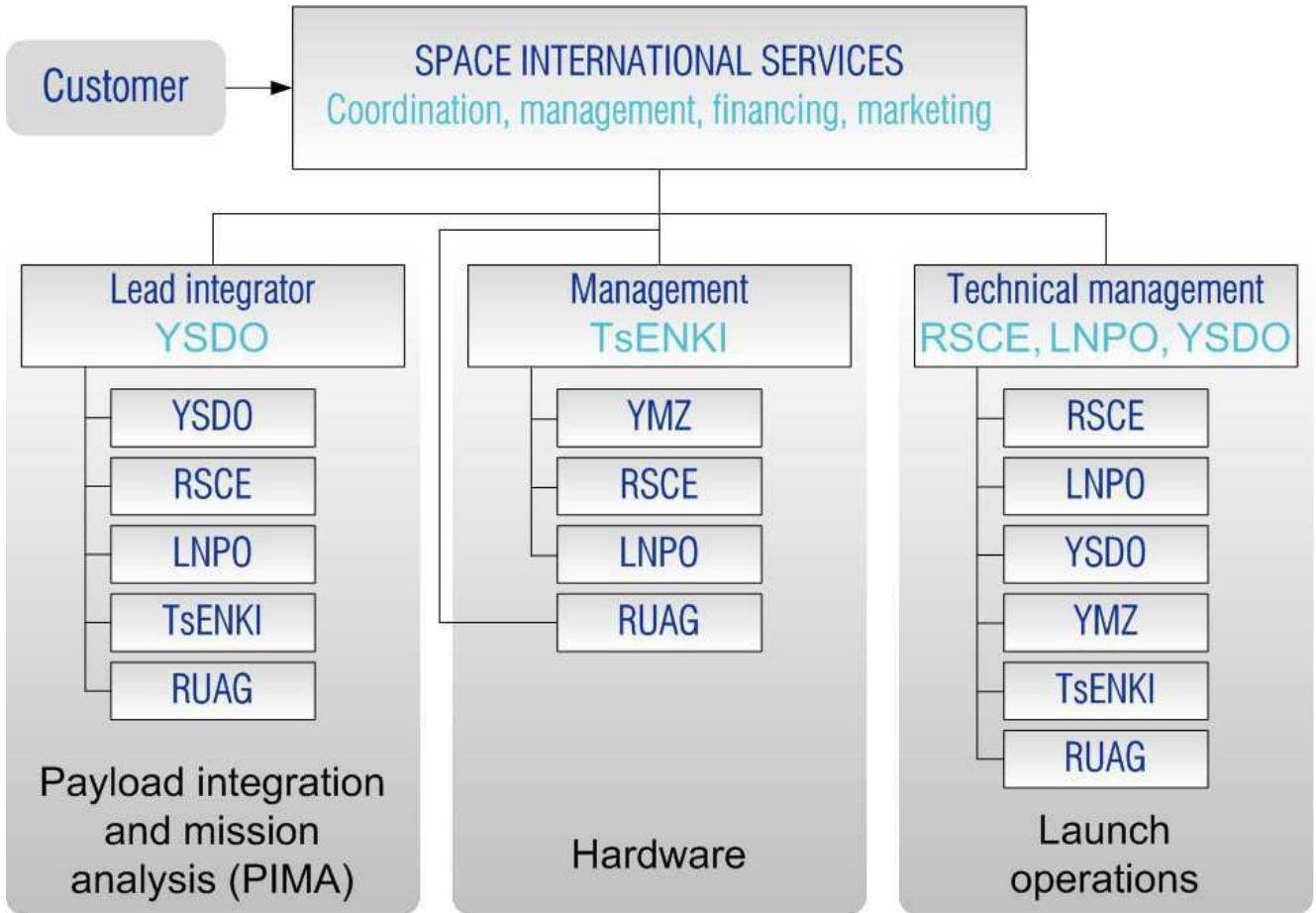

Figure. Mission activities organizational diagram

The mission activities organizational diagram above is a generic top-level diagram and provides general idea of the Land Launch partners interaction structure. It should be noted that the selection of a specific ILV configuration will impose certain adjustments to the overall work flow. For instance, technical management during upper stage and ascent unit processing steps in the course of a launch campaign will reside with a partner responsible for that specific configuration. In other words, YSDO will be responsible for the technical management for Zenit-2SLB configuration, RSCE - for Zenit-3SLB configuration, and LNPO - for Zenit-3SLBF configuration. Besides that, there is some minor deviation from the overall organizational diagram: SIS orders payload adapters and separation systems directly from RUAG while a company responsible for selected ILV configuration does the adapter analytical integration.

Space International Services

Space International Services (SIS, www.landlaunch.ru) is a joint Russian and Ukrainian company providing commercial launch services using the Land Launch system. The company was founded in 1999 and is located in Moscow, Russia. SIS activities are coordinated by Roscosmos. SIS functions in Land Launch program are:

- Land Launch marketing,

- Contracting for launch services,
- Supplier contracting and management for flight hardware,
- Supplier contracting and management for payload integration and mission analysis (PIMA),
- Supplier contracting and management for launch services support,
- Mission activities organization, management, planning and coordination,
- Payload adapter and separation system ordering,
- Auxiliary support services.

Center for Ground Space Infrastructure Operations

Center for Ground Space Infrastructure Operations (TsENKI, www.tsenki.com) operates in close association with Roscosmos. TsENKI is responsible for operations of Baikonur ground space infrastructure facilities and drop areas operations. TsENKI main functions in the Land Launch program include:

- Contracting partners for processing and support operations for SC launch,
- Organization of interaction and operations monitoring at Baikonur launch site,
- Russian launch licenses and third party insurance,
- Tracking and telemetry assets including data recording, acquisition and processing,
- Safety and security,
- Telecommunication services and communication systems,
- Logistics support (propellant components and compressed gases),
- Securing launch site support services during ILV processing and launch,
- Processing operation and maintenance of drop areas,
- Coordinating electromagnetic compatibility for ILV processing and launch operations,
- Hardware ordering (launch vehicle, upper stages, fairing),
- Customer support services during operations at Baikonur,
- SC, GSE and SC propellant customs clearance support.

TsENKI includes the following main branches that have a vast Land Launch experience and are directly involved in Land Launch program:

- NII SK - responsible for design, development, operations and PIMA as far as LV/ILV processing facility and launch complex are concerned, ILV pre-launch processing, field supervision and technical management, where applicable,
- Motor Design Bureau - responsible for PIMA portion as far as PPF, AUPF and Fregat-SB upper stage processing facility are concerned, development of applicable design documentation, design, manufacturing and operation of hoisting, assembly, transport and other equipment, field supervision and technical management, where applicable,
- KBTHM - responsible for PIMA portion as far as SC and upper stages fueling processes are concerned, HPF processes field supervision and

technical management, where applicable,

- Yuzhny Space Center - responsible for launch campaign operations, application for intended use of all processing facilities in collaboration with NII SK, Motor, KBTHM and other space industry companies and support organizations at Baikonur.

Yuzhnoye State Design Office

M.K. Yangel Yuzhnoye State Design Office (YSDO, www.yuzhnoye.com) is the leading Ukrainian aerospace organization with vast experience in the design and development of launch vehicle technology (Cosmos, Dnepr, Cyclone, Zenit vehicles and Okean, Sich, Resurs, Interkosmos satellites). YSDO is located in Dnepropetrovsk, Ukraine. YSDO launch teams together with YMZ experts have launched hundreds of launch vehicles from Baikonur. YSDO functions under Land Launch program are:

- Lead company responsible for PIMA,
- First and second stage design activities and configuration control, design support in the course of their manufacturing,
- General ILV design and development,
- Systems engineering and integration,
- AU-to-LV integration, development of respective portions of mission analysis,
- Technical management and participation in LV/ILV processing and launch operations,
- Mission operational documentation development,
- Payload adapter technical support as well as Zenit-2SLB dispenser development, manufacturing and technical support.



Figure. Zenit-2SLB

Yuzhny Machine-Building Plant

A.M. Makarov Yuzhny Machine-Building Plant Production Association (YMZ or Yuzhmash, www.yuzhmash.com) is the leading Ukrainian space hardware production entity with great experience of launch vehicles production. Yuzhmash is located in Dnepropetrovsk, Ukraine, right next to YSDO. For Land Launch program, YMZ does the following:

- ILV first and second stage manufacturing,
- ILV first and second stage processing at Baikonur,
- ILV assembly,
- ILV pre-launch operations and launch support.



Figure. ILV first stage at YMZ facility

RSC Energia

S.P. Korolev Rocket Space Corporation Energia (RSCE, www.energia.ru) is the premier Russian space company. RSC Energia, the developer of launch vehicles and propulsion systems, spacecraft, space stations, as well as manned and cargo modules. RSCE is located in Korolev, Moscow Region. RSCE is involved in Land Launch program for Zenit-3SLB configuration only. RSCE functions are:

- Design and manufacture of the Block DM-SLB upper stage (see figure below),
- Assembly and tests of the ascent unit comprising the Block DM-SLB upper stage, fairing, payload adapter system and spacecraft,
- Lead company for Zenit-3SLB ascent unit integration,
- Block DM-SLB processing at all steps,
- Launch operations support and Block DM-SLB flight support and control,
- Technical management for all operations on Block DM-SLB, ascent unit and spacecraft starting from SC and GSE arrival to Baikonur and until start of Zenit-3SLB assembly,
- Development of operational documentation for Block DM-SLB and ascent unit,
- Payload adapter technical support for Zenit-3SLB configuration.



Figure. Block DM-SLB

S.A. Lavochkin Research and Development Association

S.A. Lavochkin Research and Development Association (LNPO, www.laspace.ru) is one of the leading Russian space industry companies. It has a vast history of achievements in aircraft and space industry. LNPO is located in Khimki, Moscow region, Russia. LNPO functions for Land Launch Zenit-3SLB vehicle are:

- Fairing design activities and configuration control,
- Fairing manufacturing (see figure below),
- Fairing technical management at Baikonur,
- Fairing integration, development of applicable PIMA portions.

Besides the above, LNPO functions for Land Launch Zenit-3SLBF vehicle are:

- Design and manufacture of the Fregat-SB upper stage (see figure below),
- Assembly and tests of the ascent unit comprising the Fregat-SB upper stage, fairing, payload adapter system and spacecraft,
- Lead company for Zenit-3SLBF ascent unit integration,
- Fregat-SB processing at all steps,
- Launch operations support and Fregat-SB flight support and control,
- Technical management for all operations on Fregat-SB, ascent unit and spacecraft starting from SC and GSE arrival to Baikonur and until start of Zenit-3SLBF assembly,

- Development of operational documentation for Fregat-SB and ascent unit,
- Payload adapter technical support for Zenit-3SLBF configuration.



Figure. Land Launch fairing

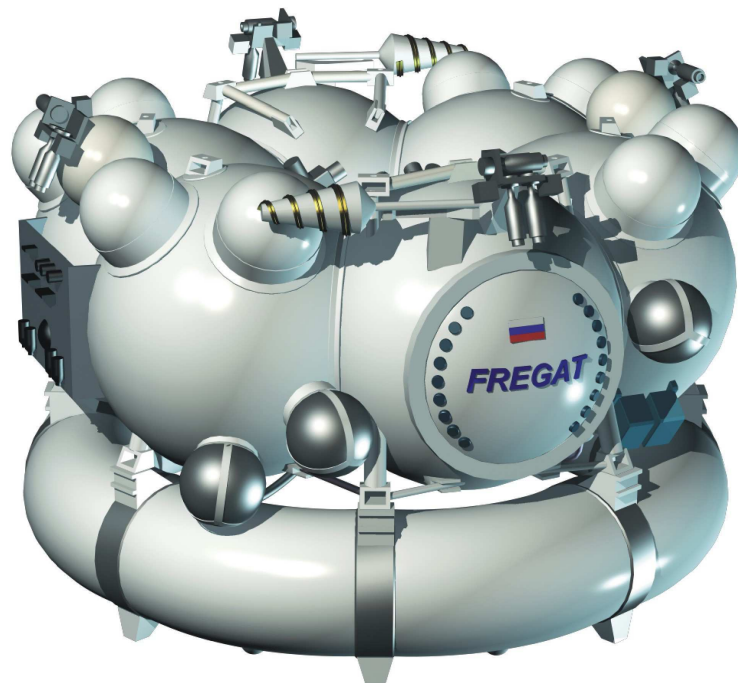

Figure. Fregat-SB upper stage

RUAG Space Sweden

RUAG Space Sweden division is located in Linköping, Sweden (www.ruag.com). In Land Launch program, RUAG is responsible for SC adapter

and separation system. RUAG adapters and separation systems have flown over 400 times including nearly 100 missions using low-shock separation systems which are being used for Land Launch. RUAG functions are:

- Design and manufacturing of payload adapter and separation system,
- Matchmate tests and/or Touch'n'Go, if required,
- Development of relevant operational documentation and adapter operations at Baikonur.

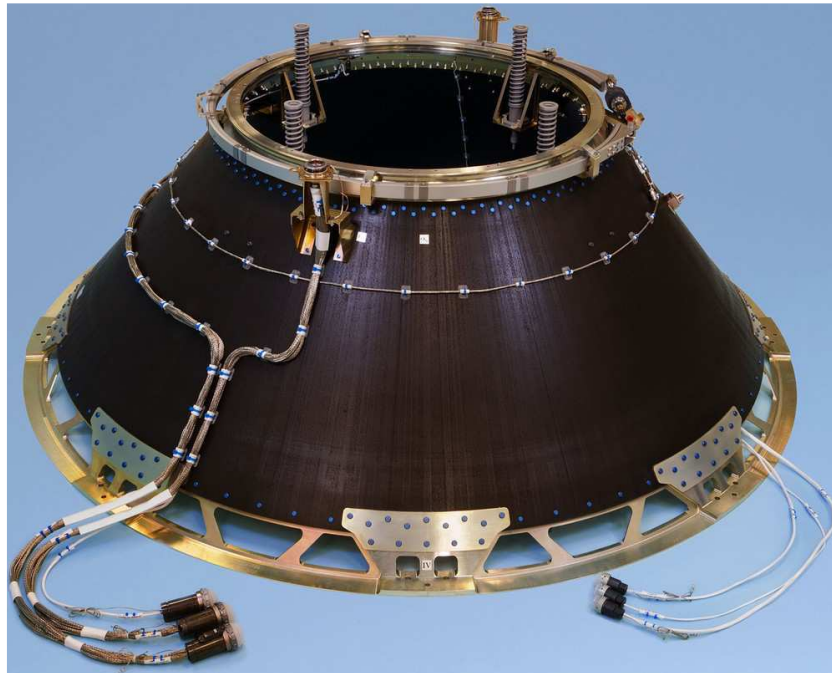

Figure. RUAG's UPAS 937S adapter

Russian Federal Space Agency

Land Launch program enjoys the support of the Russian Federal Space Agency (FSA or Roscosmos, www.roscosmos.ru). Roscosmos assists in launch licensing and interaction with other governmental agencies including foreign agencies on whose territory Land Launch activities will be conducted.

Governmental Space Agency of Ukraine

All Ukrainian space industry companies are subordinated to Governmental Space Agency of Ukraine (GSAU, www.nkau.gov.ua). For Land Launch program, GSAU provides licensing support for all delivered flight hardware and launches from Ukrainian authorities.

DESCRIPTION OF ZENIT-2SLB, ZENIT-3SLB, ZENIT-3SLBF INTEGRATED LAUNCH VEHICLES

Land Launch employs one two-stage vehicle (Zenit-2SLB) and two three-stage vehicles (Zenit-3SLB and Zenit-3SLBF). These vehicles are the successors of the Zenit launch vehicle family, The first launch of 11K77 launch vehicle that later got Zenit commercial name from Baikonur took place on 13 April 1985.

Zenit-2SLB integrated launch vehicle

The Land Launch Zenit-2SLB (see figure below) is a two-stage vehicle with a serial arrangement of stages. Diameter of both stages and the fairing is 3,9 m, overall length is 57,35 m. Zenit-2SLB integrated launch vehicle is intended for SC injection into low circular and elliptical orbits.

Zenit-2SLB integrated launch vehicle consists of:

- Zenit-2SB launch vehicle (first and second stages),
- Ascent unit (AU) (fairing, SC, SC adapter, transfer compartment (TC)).

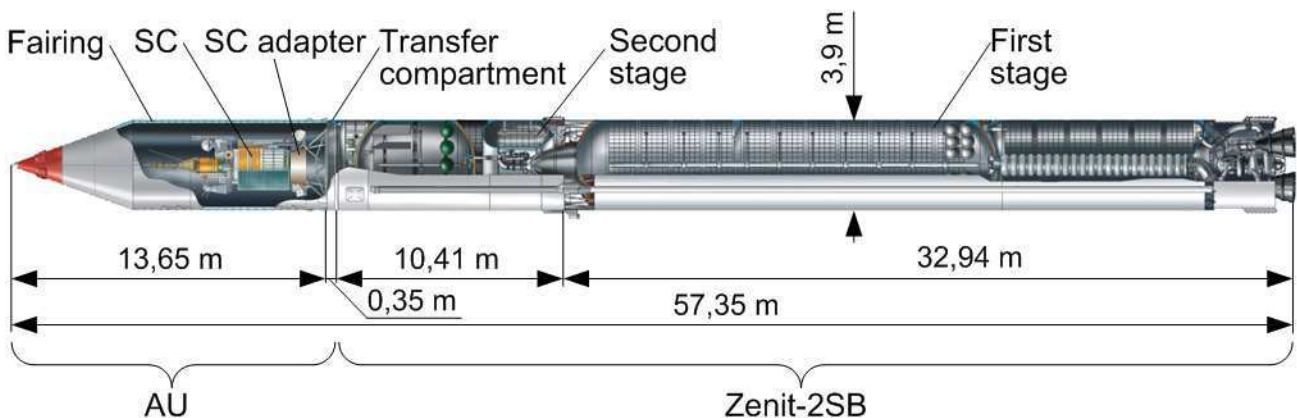

Figure. Zenit-2SLB

Zenit-2SB launch vehicle description

All Land Launch vehicles employ Zenit-2SB launch vehicle as first two stages configured identically except for a few features described in Electromagnetic Compatibility section. Technical and design parameters of Zenit-2SB launch vehicle used in Zenit-2SLB configuration are given in the table below. It should be noted that 90 % of the overall mass goes for propellant making the design of both stages one of the most effective in the world. With regard to the first stage this is mostly due to state-of-the-art parameters of RD-171M main engine and no strap-on boosters.

Table. Zenit-2SB launch vehicle technical parameters

Parameter	First stage	Second stage
Propellant: - oxidizer - fuel	Liquid oxygen Kerosene	Liquid oxygen Kerosene
Engine operation time	140 - 150 sec	300 - 1100 sec
Loaded stage mass	354350 kg	90854 kg
Fuel mass	90219 kg	23056 kg
Oxidizer mass	236567 kg	59431 kg
Length	32,94 m	10,41 m
Diameter	3,9 m	3,9 m
Engines	One RD-171M (four chambers)	One RD-120 - main engine (ME) One RD-8 - vernier engine (four chambers)
Thrust (at sea level)	740000 kgf	Not applicable
Thrust (in vacuum)	806400 kgf	Main engine - 93000 kgf Vernier engine - 8100 kgf
Specific impulse (at sea level)	309,5 sec	Not applicable
Specific impulse (in vacuum)	337,2 sec	Main engine - 350,5 sec Vernier engine - 342,8 sec
Attitude control	Nozzle gimbal	Vernier engine nozzle gimbal

The first stage includes:

- interstage frame,
- oxidizer tank,
- fuel tank,
- aft bay,
- RD-171M engine,
- onboard systems.

The interstage frame (see figure below) is a transfer compartment made as welded truss structure. It accommodates electric and pneumatic connectors side board providing vehicle and spacecraft systems link with respective ground systems prior to ILV launch.

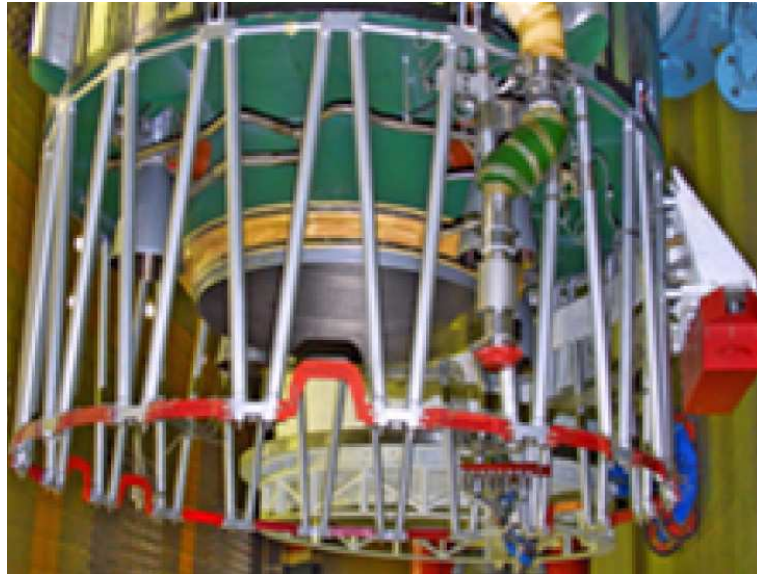

Figure. Interstage frame

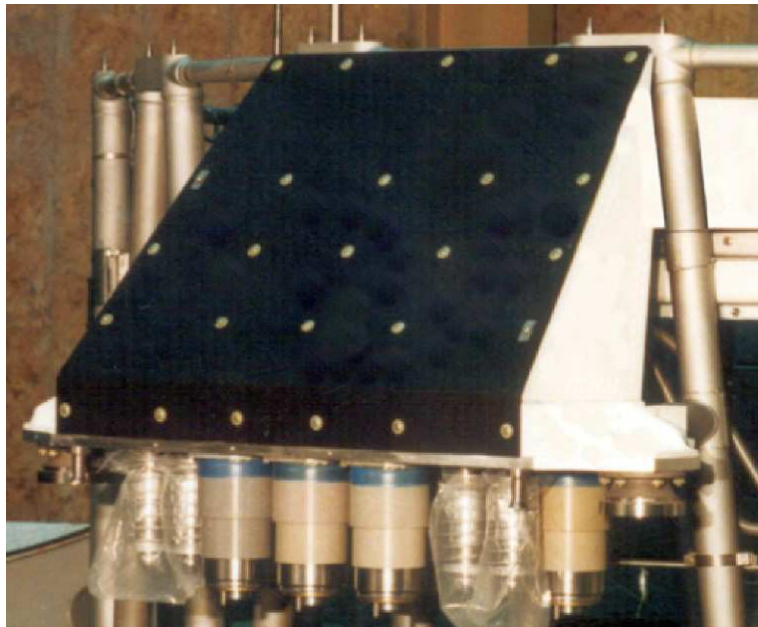

Figure. LV side board

Oxidizer and fuel tanks are welded structures made of cylindrical bodies and bottoms. Oxidizer tank bottoms are spherical, fuel tank bottoms have conical and spherical shape where spheres are bended inside tanks. Propellant tanks are equipped with sensors, loading monitoring system, automation units. Besides that, oxidizer tank is equipped with pressurization system bottles. Propellant tanks are made of aluminum alloys.

The aft bay consists of riveted load-bearing ring and waffle-structure welded cylindrical body. The load-bearing ring has built-in support brackets and ILV on-pad hold-down system elements.

The aft bay accommodates RD-171M four-chamber engine (see figure below) which is attached to the fuel tank lower butt-end ring using a rod frame.



Figure. RD-171M first stage engine

The RD-171M first stage main engine is the upgraded modification of RD-171 engine specially designed for Zenit. The engine design incorporates changes aimed towards reliability and performance enhancement. This engine is used for all Zenit first stage modifications operated up-to-date. This engine encompasses liquid propellant rocket engine advanced technologies developed by Russian engine machinery industry. As of today, RD-171M is the world's most powerful liquid propellant engine, its thrust at launch (at Earth) makes 740 tf. The engine is intended for thrust generation at all ILV stabilization channels. The engine is a four thrust chambers liquid propellant rocket engine fed by a single turbopump and two booster pumps for oxidizer and fuel. The engine runs on environment friendly liquid oxygen and kerosene. Flight control is achieved by gimbaling the independently suspended combustion chambers, while the ability to throttle down to approximately 74 % of nominal full-engine thrust provides great flexibility in trajectory design.

Generation of thrust forces for all control channels during first stage flight is assured by engine combustion chamber pitch swing using hydraulic actuators system.

Stages "hot" separation is done by ignition of second stage vernier engine, firing of interstage mechanical interfaces and braking using four solid rocket boosters (SRB) accommodated on the outer surface of the aft bay beneath the covers. Once the separated unit reaches a safe distance, the second stage main engine (ME) ignites.

First stages for all Land Launch vehicle configurations are produced on one and the same production line at Yuzhmash.

The second stage includes:

- instrumentation bay,
- oxidizer tank,
- fuel tank,
- aft bay,
- RD-120 ME,
- RD 8 vernier engine.

The instrumentation bay is a cylindrical riveted load-bearing shell and accommodates the most portion of control system and measurement system on-board radio and electronic equipment.

The launch vehicle employs modern digital inertial autonomous control system.

The oxidizer tank is a welded cylindrical vessel consisting of a body and spherical bottoms. The fuel tank is a torus-shaped welded structure consisting of inner and outer cylindrical bodies with bottoms welded on top and bottom. Due to this fuel tank torus-shape, the stage inner volume is used more effectively reducing its length. Propellant tanks are equipped with sensors, loading monitoring system, automation units. Besides that, oxidizer tank is equipped with pressurization system bottles.

The aft bay (see figure below) is a riveted cylindrical load-bearing shell and is intended for accommodation of the propulsion system consisting of RD-120 one-chamber main engine (see figure below) and RD-8 four-chamber vernier engine (see figure below). The main engine is located in inner "dry" cavity of fuel torus-shape tank and is attached to its lower bottom via a frame. The vernier engine combustion chambers and turbopump are fixed using brackets located at aft bay body.



Figure. Second stage aft bay

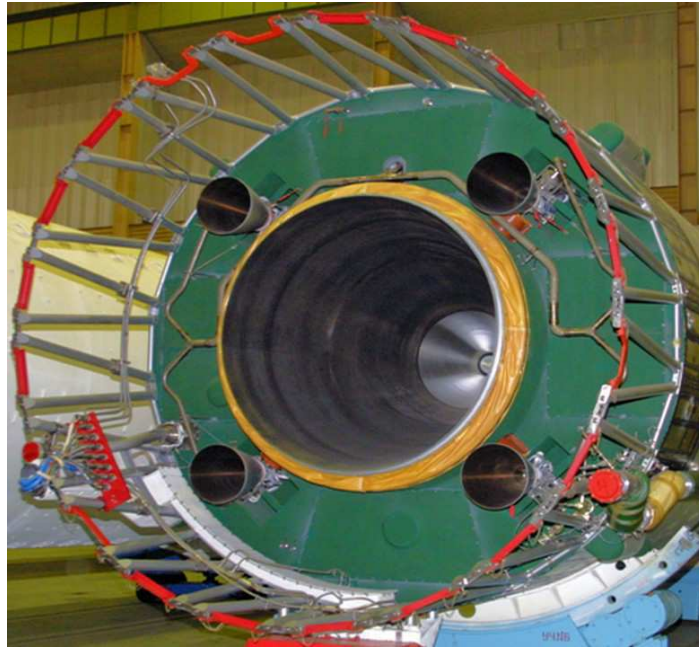

Figure. RD-120 and RD-8 second stage engines

The outer surface of aft bay body accommodates four SRBs used for second stage brake during separation of the second stage from a spacecraft (for Zenit-2SLB configuration) or from upper stages (for three-stage configurations).

Generation of thrust forces for all control channels during second stage flight is assured by vernier engine combustion chamber pitch swing using hydraulic actuators.

The second stage body is mainly produced from aluminum alloys. Second stages for all Land Launch vehicle configurations are produced on one and the same production line at Yuzhmash.

Zenit-2SLB ascent unit

The Zenit-2SLB ascent unit (see figure below) includes:

- Fairing,
- Transfer compartment,
- SC adapter,
- SC.

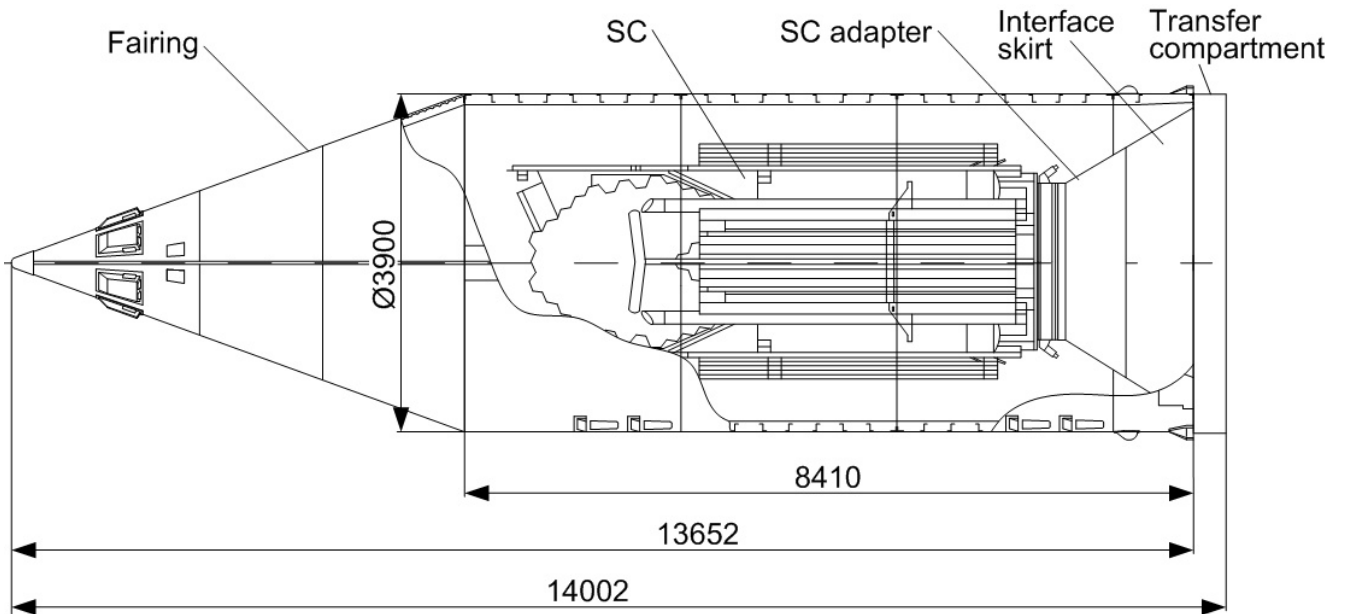

Figure. Zenit-2SLB ascent unit

The fairing is intended for SC protection from unfriendly environment in the course of pre-launch operations and during flight. Zenit-2SLB fairing is 13652 mm long and 3900 mm in diameter; it is produced at Yuzhmash. The Land Launch Zenit-2SLB fairing (see figure below) is developed on the basis of original Zenit fairing modified in terms of meeting payload cleanliness requirements, thermal and humidity environment requirements at all steps of operations.

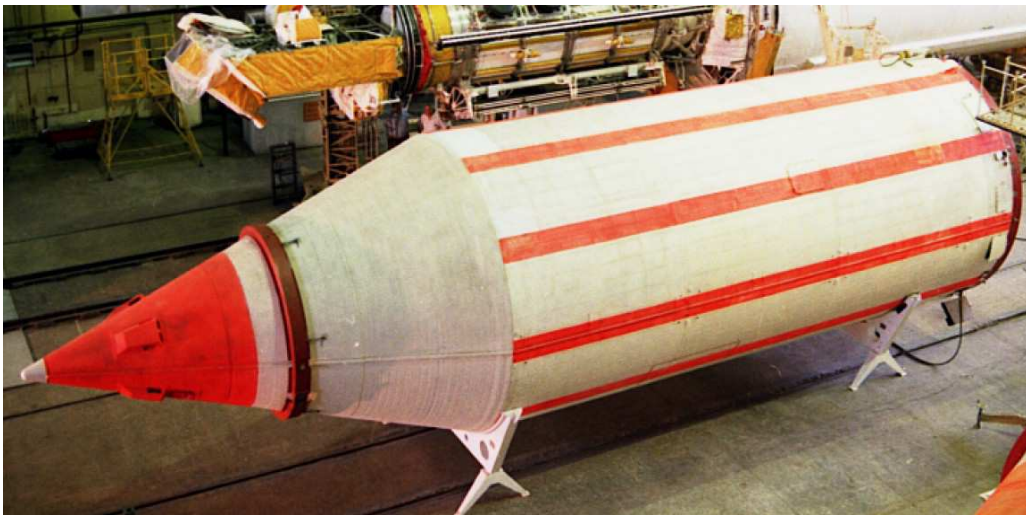

Figure. Zenit-2SLB fairing

The Zenit-2SLB fairing is a riveted structure of aluminum alloys. The fairing consists of four cylindrical and two conical sections connected by bolts and end caps. The sections have lateral and longitudinal force structures. All sections have longitudinal joint dividing fairing into two halves.

Lever and cam locks and pins are installed along the longitudinal joint. The locks are held down in closed position by rods fixed by stopping pyrodevices. Fairing lower section has pneumatic system for fairing halves jettison which includes high pressure bottles, pneumatic pushers, tubing and automation units.

Thermal insulation is available at the fairing inner surface assuring SC thermal requirements. The outer surface of conical part and upper portion of fairing cylinder has heat-resistant coating.

In support of clean environment inside the fairing during ground operations the Zenit-2SLB fairing has four special self-closing hatches for air supply from the temperature control systems starting from encapsulation and until transporter/erector boom removal and during transportation between facilities. In vicinity of the air inlet hatches at the fairing inner side collectors are installed. The fairing upper conical section has six temperature controlled air outlets installed with check valves. Once transporter/erector is removed at L-12 minutes, the air supply is provided by high pressure temperature control system (HPTS). For this purpose the Zenit-2SLB interior is equipped with tubing and a special diffuser.

Access inside Zenit-2SLB fairing is provided via access hatches (see hatches description in Interfaces section).

The transfer compartment provides unification of Zenit-2SB launch vehicle for Land Launch integrated launch vehicles. AU TC lower end is mated with the Zenit-2SB instrumentation bay upper end. Depending on the option of Zenit-2SLB assembly the AU may be assembled as single assembly unit at the AUPF or as part of ILV only for the case of serial assembly at LV/ILV processing facility. AU TC allows for SC vertical mating for Zenit-2SLB integrated launch vehicle.

Land Launch Zenit-2SLB employs RUAG adapters UPAS 937S and UPAS 1194VS for SC mating to the vehicle. Adapters are being installed onto interface skirt providing mechanical interface between adapter and TC. Besides that, integration of other adapter types and interfaces is also possible. For multiple SC launches the LSP can develop and manufacture a dispenser (see figure below). Dispenser activities can be accommodated within the mission integration cycle.



Figure. 12-spacecraft dispenser

Zenit-3SLB integrated launch vehicle

The Land Launch Zenit-3SLB (see figure below) is a three-stage vehicle with a serial arrangement of stages. Zenit-2SB launch vehicle is used as first two stages with Block DM-SLB being a third or upper stage. Diameter of Block DM-SLB is 3,7 m, fairing diameter is 4,1 m. Zenit-3SLB overall length is 58,65 m (when using 10,4 m fairing). Zenit-3SLB integrated launch vehicle is intended for middle-class SC injection into middle and high elliptical orbits including geotransfer orbits (GTO) and geostationary orbits (GEO) as well as escape trajectories.

Zenit-3SLB integrated launch vehicle consists of:

- Zenit-2SB launch vehicle (see description above),
- Ascent unit (AU) (Block DM-SLB upper stage, SC, SC adapter, fairing).

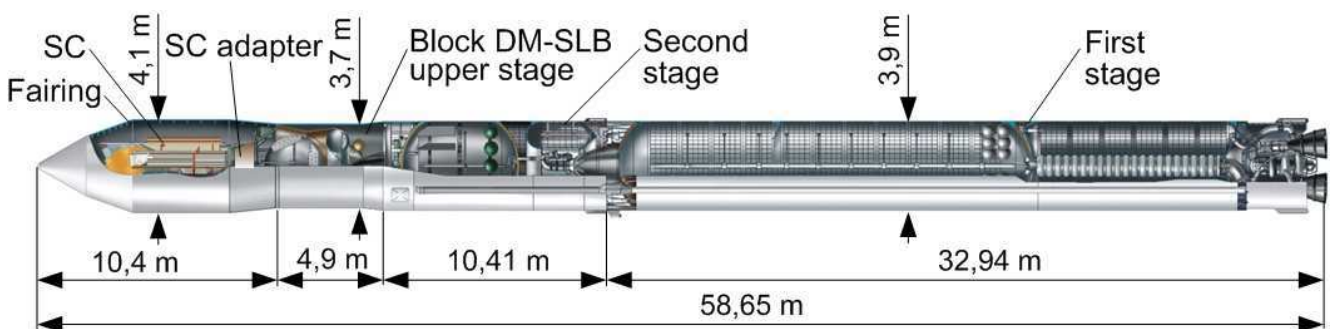

Figure. Zenit-3SLB

Zenit-3SLB ascent unit

The Zenit-3SLB ascent unit (see figure below) includes:

- Block DM-SLB upper stage,
- Fairing,
- SC,
- SC adapter.

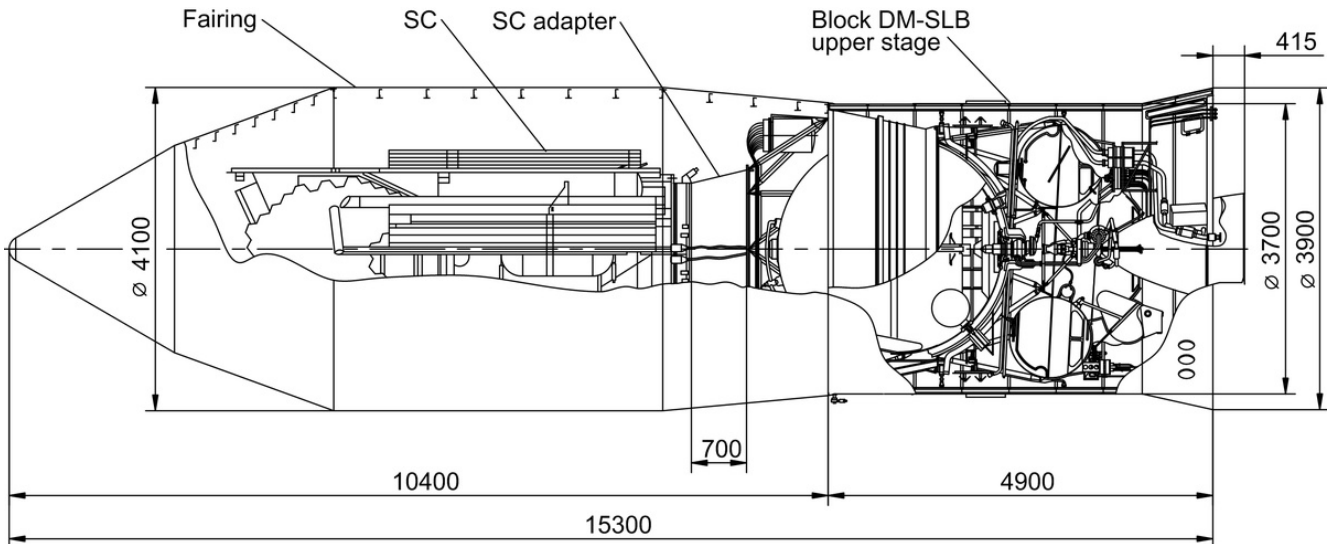

Figure. Zenit-3SLB ascent unit

The Block DM-SLB upper stage (see figure below) employed in Zenit-3SLB integrated launch vehicle is designed specifically for Land Launch program and is a derivative of Block DM family heritage. The upper stage uses liquid oxygen and kerosene (or synthine - synthetic hydrocarbon fuel) as propellant and is capable of igniting up to five times during its flight. The main technical parameters of Block DM-SLB upper stage are shown in table below.

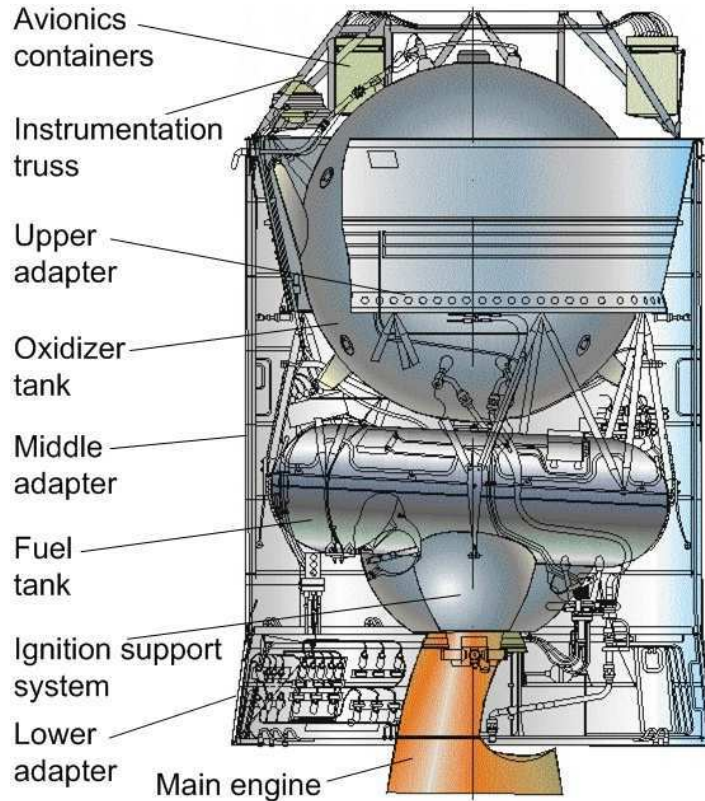

Figure. Block DM-SLB upper stage

Table. Block DM-SLB upper stage main technical parameters

Parameter	Value
Length	5,93 m
Diameter (measured at middle adapter)	3,7 m
Fully assembled and loaded upper stage mass	17800 kg
Maximal usable propellant reserve	14580 kg
ME nominal thrust in vacuum: - with kerosene as propellant - with synthine as propellant	8103 kgf 8369 kgf
ME nominal specific impulse in vacuum: - with kerosene as propellant - with synthine as propellant	356 sec 365 sec

The main structure of the Block DM-SLB includes upper adapter together with internal truss. The middle and lower adapters that enclose the stage are jettisoned before first ignition of the 11D58M main engine. Kerosene is contained in a torus-shape tank attached by inner truss to the upper adapter which encircles the main engine turbopump. The spherical liquid oxygen tank and the avionics/payload truss are located above the kerosene tank, and are also attached to the upper adapter.

The Block DM-SLB upper stage employs modern digital inertial autonomous control system.

The Block DM-SLB upper stage is powered by the main engine, which operates on liquid oxygen and kerosene. Its nozzle is gimballed to provide pitch and yaw stabilization during powered flight. Roll control is provided by roll nozzle (low-thrust nozzle) using gas coming from turbopump.

Three-axis stabilization and attitude control during coast periods, including continuous rolls, are provided by attitude and ignition propulsion systems using hypergolic propellants that are located below the kerosene tank, on both sides of the main engine nozzle.

The Zenit-3SLB fairing (see figure below) is an aluminum structure consisting of nose portion made as double cone, cylindrical part and rear (reverse) cone. For Land Launch Zenit-3SLB vehicle two fairings may be used - 10,4 m long and 11,35 m long. The only difference is the length of cylindrical part. Both fairings are 4,1 m in diameter. Fairing halves jettison system is based on ampoule-type pneumatic pushers that avoid SC contamination. Access inside Zenit-3SLB fairing is provided via access hatches (see hatches description in Interfaces section).



Figure. Zenit-3SLB fairing

In support of clean environment inside the fairing during ground operations the Zenit-3SLB fairing has two air inlets for air supply with a given temperature from the temperature control systems starting from AU transportation and until transporter/erector boom removal and during transportation between facilities. Once transporter/erector is removed at L-12 minutes, the air supply is provided by the HPTS. For this purpose the ILV interior is equipped with tubing and a special diffuser.

Fairing internal thermal insulation prevents SC structure from overheating and preserves acceptable thermal conditions throughout all operational steps.

Land Launch Zenit-3SLB employs RUAG adapters UPAS 937S and UPAS 1194VS for SC mating to the vehicle. Adapters are being installed onto Block DM-SLB truss. Besides that, accommodation of other adapter types and interfaces is also possible.

Zenit-3SLBF integrated launch vehicle

The Land Launch Zenit-3SLBF (see figure below) is a three-stage vehicle with a serial arrangement of stages. Zenit-2SB launch vehicle is used as first two stages with Fregat-SB being a third or upper stage. Diameter of the upper stage is 3,9 m, fairing diameter is 4,1 m. Zenit-3SLBF overall length is 54,3 m (when using 10,4 m fairing). Zenit-3SLBF integrated launch vehicle is intended for middle-class SC injection into middle and high elliptical orbits including GTO and GEO as well as escape trajectories.

Zenit-3SLBF integrated launch vehicle consists of:

- Zenit-2SB launch vehicle (see description above),
- Ascent unit (Fregat-SB upper stage, SC, SC adapter, fairing, TC).

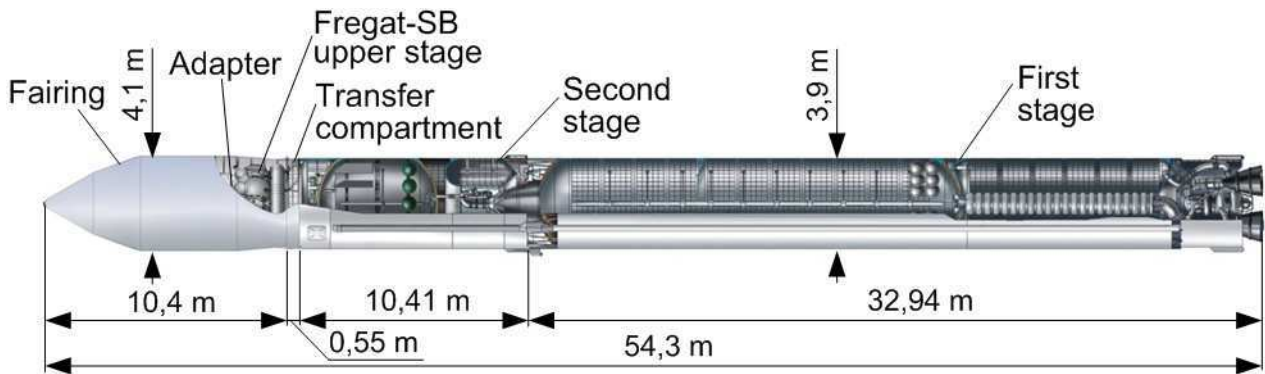

Figure. Zenit-3SLBF integrated launch vehicle

Zenit-3SLBF ascent unit

The Zenit-3SLBF ascent unit (see figure below) includes:

- Fregat-SB upper stage,
- Fairing,
- SC,
- SC adapter,
- Transfer compartment.

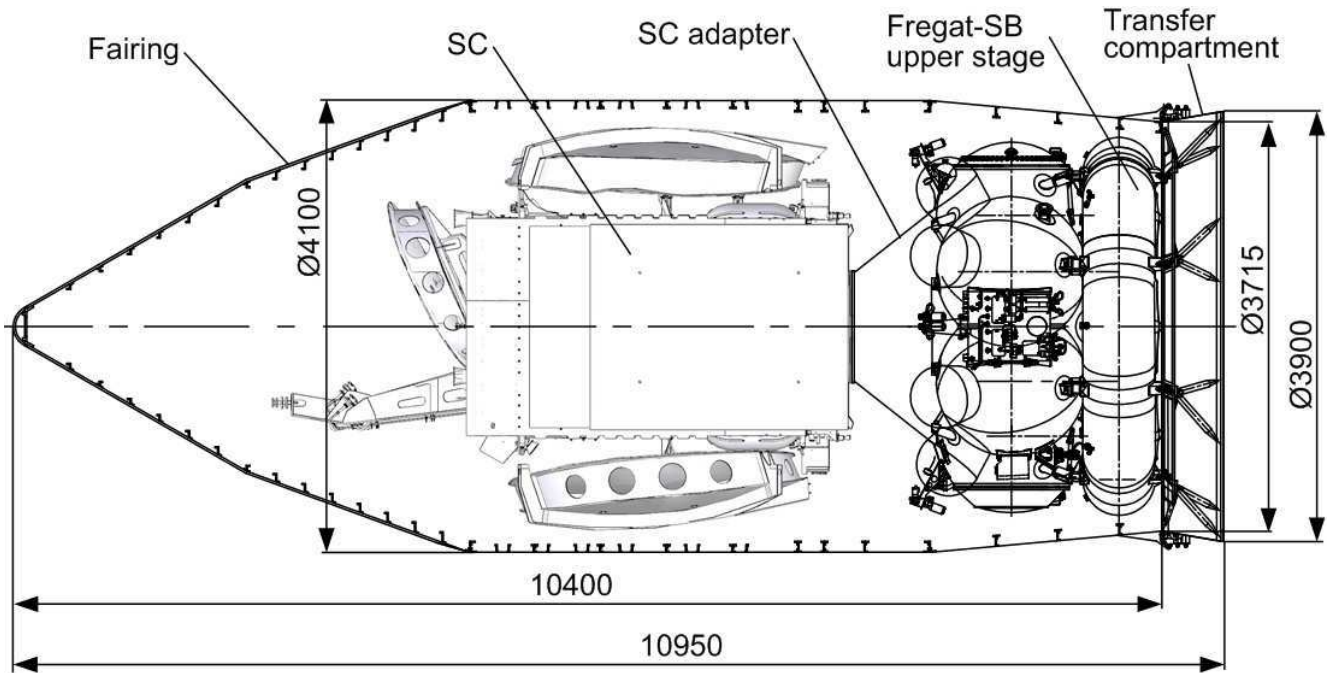

Figure. Zenit-3SLBF ascent unit

Fregat-SB upper stage (see figure below) employed in Zenit-3SLBF integrated launch vehicle is based on Fregat upper stage which is used for Soyuz launches. Unlike the original Fregat, Fregat-SB has extra jettisoned tanks block (JTB). The main tanks block is attached to the JTB via eight brackets installed on JTB interface pads. The main technical parameters of Fregat-SB upper stage are shown in table below.

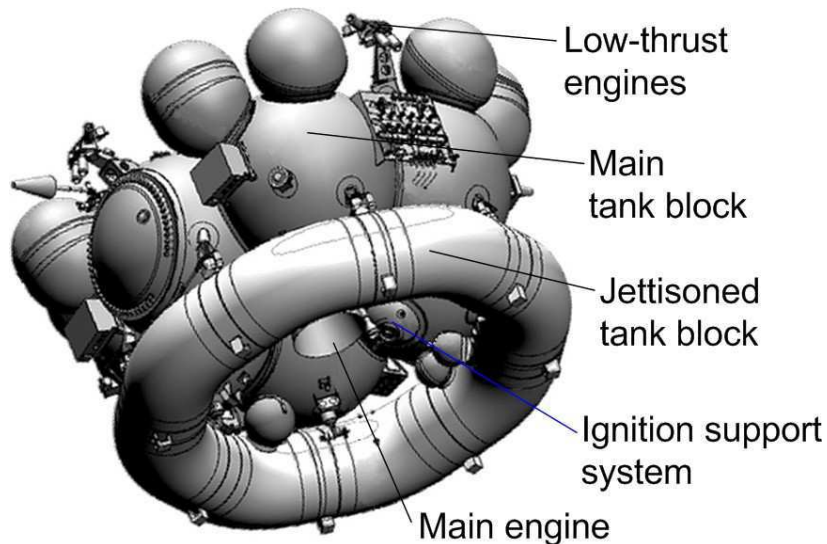

Figure. Fregat-SB upper stage

Table. Fregat-SB upper stage main technical parameters

Parameter	Value
Length	2,4 m
Diameter (envelope circle)	3,9 m
Fully assembled and loaded upper stage mass	11781 kg
Maximal usable propellant reserve	10461 kg
ME nominal thrust in vacuum: - low thrust - high thrust	1418 kgf 2038 kgf
ME nominal specific impulse in vacuum: - low thrust - high thrust	320 sec 333,2 sec

The primary structure of Fregat-SB is the block of tanks for the main engine. The torus-shaped block of tanks is made of six spherical vessels welded into one structure. Four vessels accommodate propellants (fuel and oxidizer), two others are instrumentation bays. Inner cavity of tanks block accommodates S5.92 main engine and steering actuators. Upper surface of main tanks block has eight brackets that take loads acting at the Fregat-SB/SC adapter interface. For the purpose of usable propellant increase each tank of main propulsion system anticipates installation of additional spherical vessels that have single volume with main tanks.

The block of jettisoned tanks is a torus-shape block. It accommodates two fuel tanks and two oxidizer tanks separated by spherical bottoms from each other. Eight bulkheads of block of jettisoned tanks have upper and lower nodes connected in pairs by load-bearing studs for force transfer from upper stage with SC down to the vehicle. The JTB is equipped with high pressure helium bottles for tank supercharging, cable cut units at upper stage interface, tear-off pyroboards, onboard transit harness. Prior to JTB separation from the upper stage propellant and gas lines and transit cables are disconnected.

The S5.92 main engine is intended for generation of upper stage velocity and stabilization longitudinal impulses along lateral axes during powered flight. The stabilizing moment is generated by ME chamber shift relative to longitudinal axis along two lateral axes. The ME can operate on low thrust and high thrust with up to ten ignitions.

The ignition support propulsion system is intended for generation of velocity impulses, ME ignition support, upper stage stabilization and attitude control along three axes during coast flight and stabilization along longitudinal axis during ME operation.

The Fregat-SB upper stage employs modern digital inertial autonomous control system.

Similar to Zenit-3SLB, Zenit-3SLBF may employ two modifications of the fairing (see description above) with different cylindrical part length.

The transfer compartment intended for mating the AU with the launch vehicle is produced by LNPO. Once the upper stage with a SC separates from the launch vehicle, the transfer compartment stays together with the second stage.

Land Launch Zenit-3SLB employs RUAG adapters UPAS 937S and UPAS 1194VS for SC mating to the vehicle. Adapters are being installed onto Fregat-SB upper stage. Besides that, accommodation of other adapter types and interfaces is also possible.

LAND LAUNCH SYSTEM PERFORMANCE

Basic provisions

The Land Launch launch vehicles provides SC injection into various orbits including low earth orbits (LEO), middle earth orbits (MEO), high earth orbits (HEO), geotransfer orbits (GTO), high elliptical orbits as well as geostationary orbits (GEO) and escape trajectories. Data presented in this section is intended to enable prospective users to make preliminary ILV performance assessments. Please contact Space International Services for a performance quote specific to your mission requirements.

The description of Land Launch system performance includes:

- Launch window availability,
- Launch site and accessible orbits,
- Generic ascent trajectories,
- Mass performance,
- Coast phase maneuvering,
- Injection accuracy,
- SC separation conditions.

The ILVs and supporting ground infrastructure provides launch capabilities throughout the year and round-the-clock at ambient air temperature off from -29 °C to +45 °C, at ground wind velocity at 10 meters above the ground up to 20 m/sec for Zenit-2SLB and up to 18 m/sec for Zenit-3SLB and Zenit-3SLBF assuming relative humidity of up to 98 % (at +20 °C), during fog, rain, snow, hail. No launch can occur during lightning and thunderstorms.

During the launches the basic directions are used The currently approved launch azimuths available for the Land Launch System, as constrained by ground track and drop zone considerations are shown on figure below. The figure shows potential launch azimuths and initial orbit inclinations available for Land Launch without LV or upper stages side maneuvering.

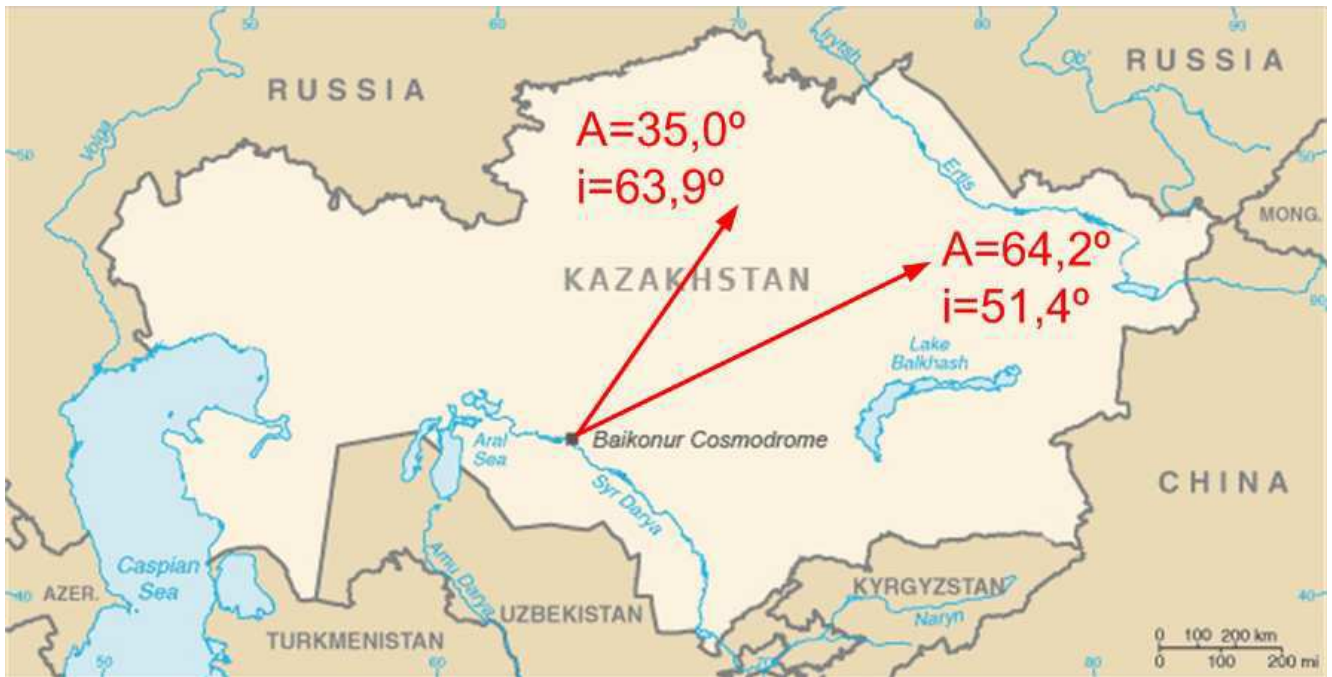

Figure. Land Launch system basic launch directions

For LEO missions with inclinations different from basic directions cross-range yaw maneuvering may be introduced during second stage flight after fairing jettison. Such maneuvers usually take place during Zenit-2SLB missions where a LEO is the final target orbit. For Zenit-3SLB and Zenit-3SLBF missions involving higher orbits where the required inclination differs from basic inclinations it is typically most efficient for plane changes to be carried out primarily by upper stages maneuvering. In such cases, the first two ILV stages usually perform a direct ascent into a reference orbit inclination coinciding with basic directions.

Performance losses due to plane changes are highly sensitive to a variety of mission parameters. Consequently, prospective Land Launch Customers are encouraged to contact Space International Services for a performance estimate that is specific to their needs.

Performance data in this section is based on the following set of ground rules:

- Payload capability, defined in terms of payload systems mass,
- The payload systems mass is the sum of the separated spacecraft mass, adapter mass (and interface skirt for Zenit-2SLB) and mass of any mission-specific hardware required by Customers (e.g. gas purge equipment),
- The maximum payload systems mass for Zenit-3SLB and Zenit-3SLBF are 5000 kg and 4500 kg respectively due to upper stages structural limitations. For Zenit-2SLB missions, structural limitations are not applicable since ILV strength is sufficient for ascent of significantly higher masses,
- To achieve orbit within the desired accuracy, and perform

Contamination and Collision Avoidance Maneuver (CCAM), sufficient propellant reserves are assured for each individual stage to account for all launch vehicle dispersions and possible ambient conditions with at least 0,9965 probability,

- The spacecraft is injected into orbit via trajectories that are consistent with existing, approved launch corridors and drop zones,
- Orbital altitudes are specified with respect to an Earth radius of 6378 km,
- Mission-unique Customer requirements that may affect ILV performance (e.g. specific argument of perigee, restricted mission duration, extended launch windows, etc.) are not factored.

Zenit-2SLB payload capabilities

The two-stage Zenit-2SLB is capable of performing low circular and elliptical orbits. The tables and figures below provide Zenit-2SLB performance into the above mentioned orbits. In case of need for a specific ILV performance for any kind of orbit Customers are encouraged to contact the LSP.

Table. Zenit-2SLB circular LEO payload capability

Height, km	Payload mass, kg	
	$i = 51,4^\circ$	$i = 63,9^\circ$
200	13920	13330
300	12940	12410
400	11930	11500
500	10890	10550
600	9820	9570
700	8730	8560
800	7630	7550
900	6530	6510
1000	5420	5480
1100	4660	4560
1200	4250	4190
1300	3810	3750
1400	3390	3310
1500	2930	2340

Note:
- The payload mass includes adapter mass

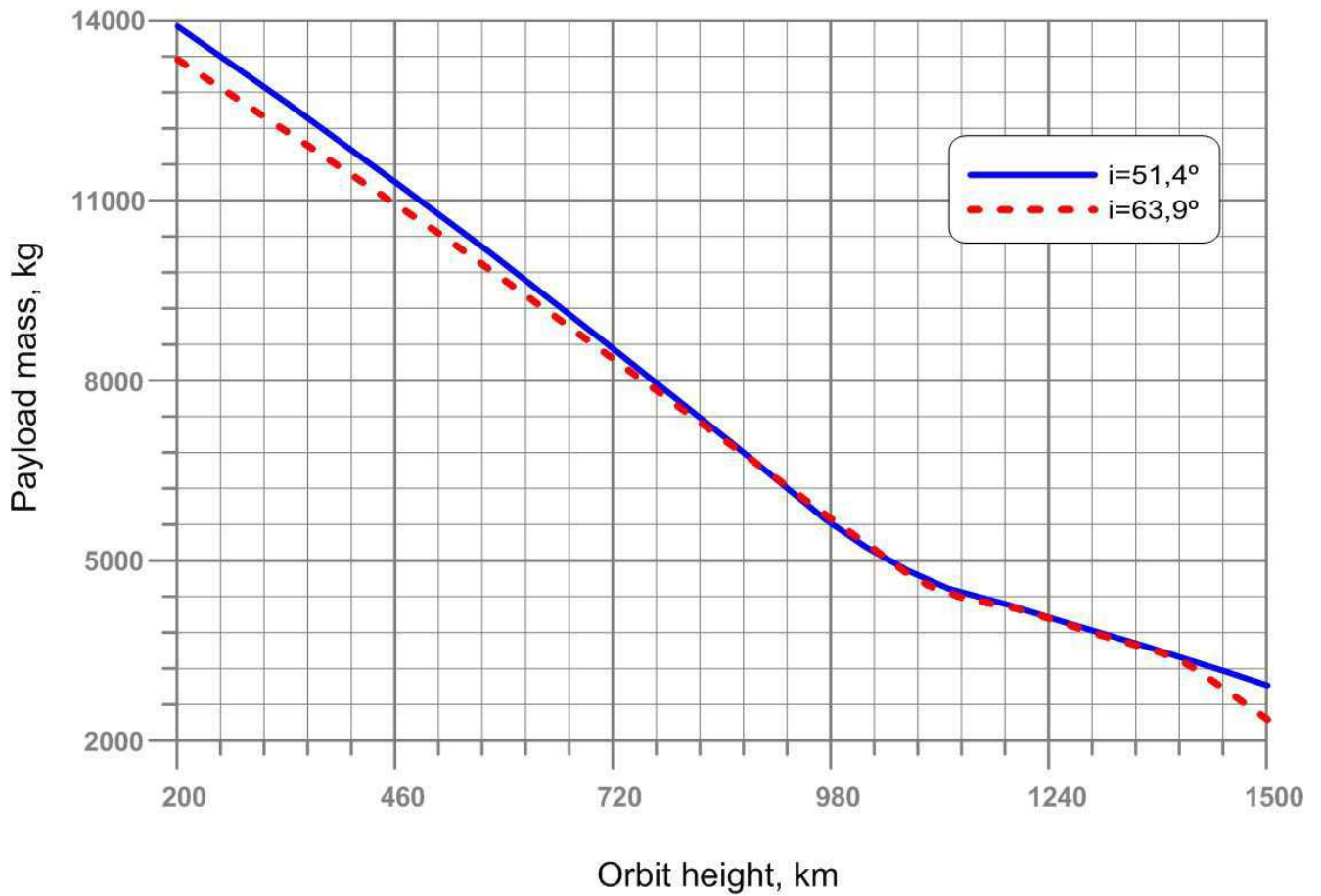

Figure. Zenit-2SLB circular LEO payload capability

Table. Zenit-2SLB elliptical earth orbits payload capability

Apogee, km	Payload mass, kg	
	$i = 51,4^\circ$	$i = 63,9^\circ$
500	13280	12730
1000	12320	11800
2000	10710	10230
4000	8290	7900
6000	6560	6290
8000	5260	5120
10000	4250	4230

Note:
 - Perigee height of 200 km
 - The payload mass includes adapter mass

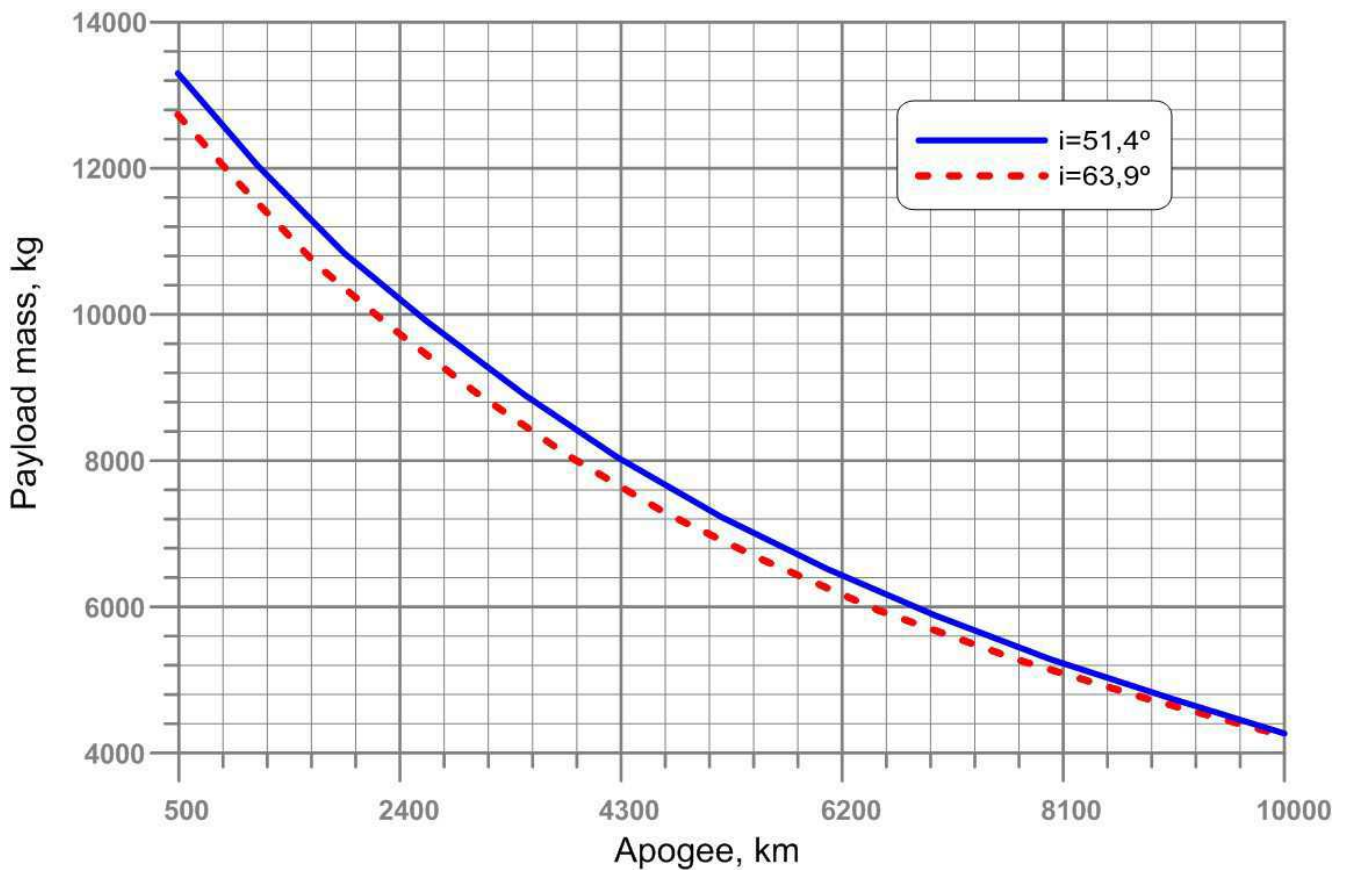

Figure. Zenit-2SLB elliptical earth orbits payload capability

Zenit-2SLB generic ascent trajectory

The example below is attributable to a $51,6^\circ$ LEO mission.

For such missions, the Zenit-2SLB first stage uses the same basic launch direction and the assigned drop zone for the first stage and the fairing, namely, the launch azimuth $A = 64,2^\circ$ and inclination $i = 51,4^\circ$. Lift-off occurs 3,9 seconds after first stage propulsion system ignition upon release of the

launch pad hold-downs. The roll maneuver begins at L+10 sec. Main engine thrust is provided for the first 140-150 seconds of flight. The engine is throttled during its last seconds of operation so to limit maximum axial acceleration. Throughout this phase of the mission, the telemetry information (TMI) is received by ground control stations.

The Zenit second stage vernier engine ignites prior to first stage separation. Once first and second stages are separated, the first stage solid rocket boosters fire and second stage main engine ignition occurs. The main engine and vernier engines continue to operate in tandem for the next four minutes of flight.

Fairing jettison occurs at about 295 sec of flight. After fairing jettison, the second stage performs a cross-range yaw maneuver to adjust the inclination to 51,6 °.

After second stage main engine cut-off, the vernier engine continues to function for additional 500 seconds to provide attitude control up through payload separation. Throughout this phase of the mission, the TMI is received by ground control stations.

The following table depicts typical sequence for generic Zenit-2SLB missions for payload mass of 12000 kg for 51,6 ° / 400 km LEO. An approximate ground track is shown on figure below.

Table. Zenit-2SLB generic flight timeline

Time, sec	Mission event
0	Engine ignition
3,9	Lift-off
10	Begin roll
11	Begin pitch over
14	Roll to launch azimuth
60	Maximal dynamic pressure
113	Maximal axial acceleration
from 113 up to 132	First stage main engine throttling
145	Second stage vernier engine ignition
147	First stage main engine cut-off
149	First stage separation
155	Second stage main engine ignition
295	Fairing jettison
397	Second stage main engine cut-off
893,5	Second stage vernier engine cut-off
893,8	SC separation pyros firing
893,86	SRBs firing

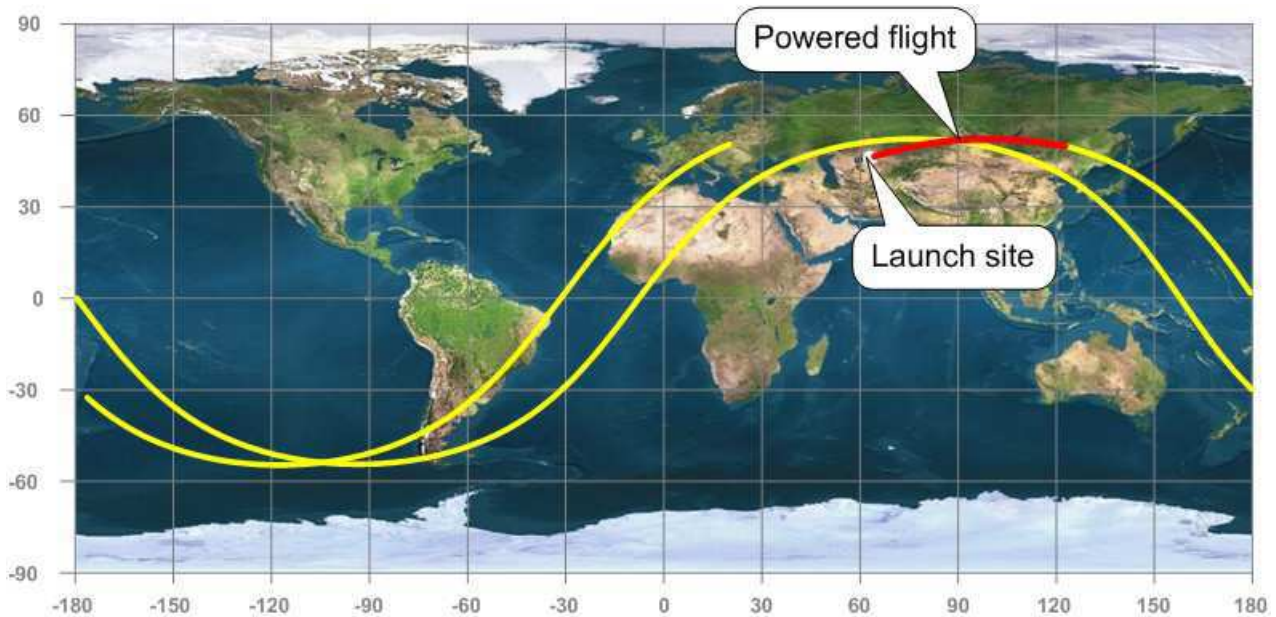

Figure. Zenit-2SLB 51,6 ° LEO ground track

Zenit-2SLB missions do not anticipate long coastal maneuvering. Second stage operation starts right the first stage operation is complete.

Zenit-2SLB separation conditions and injection accuracy

SC separation occurs 0,3 - 5 sec after second stage vernier engine shutdown. Zenit-2SLB employs generic Land Launch SC separation scheme based on clamp band type attachment which includes fast-response low-shock clamp

band opening device (CBOD) developed by RUAG. The relative SC separation velocity is supported by a set of separation spring set. Land Launch adapters are not sources of mechanical or outgassing contamination during SC separation. For a cluster launch, the LSP can offer a dedicated dispenser.

Almost simultaneously with the impulse imparted by separation springs the SRBs fire. Those are located on the second stage aft end thus increasing the separation relative velocity.

SC motion parameters after separation shall be agreed with Customers. Attitude accuracy and relative and angular velocity values dramatically depend on SC mass and inertia properties and shall be specified during the payload integration and mission analysis phase.

The state vector during SC separation may be provided to Customers 50 minutes after separation. The format of the state vector shall be concurred with Customers.

The table below depicts SC insertion accuracy (3σ) using Zenit-2SLB into a generic orbit.

Table. Zenit-2SLB accuracy

Orbit parameter	Circular (400 km x 400 km, $i = 51,4^\circ$)
Orbit height, km	± 8
Inclination, deg.	$\pm 0,04$
Longitude of ascending node, deg.	$\pm 0,1$
Period, sec	$\pm 3,5$

Zenit-3SLB and Zenit-3SLBF payload capabilities

The three-stage Zenit-3SLB and Zenit-3SLBF are intended for SC injection into middle and high circular and elliptical orbits including GTO and GEO and escape trajectories. The ILV performance into the above mentioned orbits are shown below. In case of need for a specific ILV performance for any kind of orbit Customers are encouraged to contact the LSP.

The Land Launch Zenit-3SLB and Zenit-3SLBF vehicles allow middle-weight spacecraft insertion into GTO. A three-stage integrated launch vehicle is capable of delivering a payload mass of 4000 kg into GTO with high apogee and reduced inclination requiring delta velocity of 1500 m/sec to GEO using three burns of Block DM-SLB upper stage or four burns of Fregat-SB upper stage. The tables and figure below provide Zenit-3SLB and Zenit-3SLBF performance into GTO.

Table. Zenit-3SLB GTO payload capability

Delta-V to GEO, m/sec	Inclination, °	Perigee, km	Payload mass, kg
0	0,0	35786	1750
1000	13,0	9430	3150
1500	23,2	4100	4000
1800	31,0	2120	4560

Note:

- Apogee height of 35786 km
- Initial inclination of 51,4 °
- Mission duration approximately 6,6 hours
- Argument of perigee of 0 °
- Payload mass includes adapter mass

Table. Zenit-3SLBF GTO payload capability

Delta-V to GEO, m/sec	Inclination, °	Perigee, km	Payload mass, kg
0	0,00	35786	1900
1000	13,0	9430	3200
1500	23,2	4100	4000
1800	31,4	2350	4500

Note:

- Apogee height of 35786 км
- Initial inclination of 51,4 °
- Mission duration approximately 8,5 hours for SC weighting over 3000 kg
- Argument of perigee of 0 °
- Fregat-SB upper stage load capability limitation is 4500 kg
- Payload mass includes adapter mass

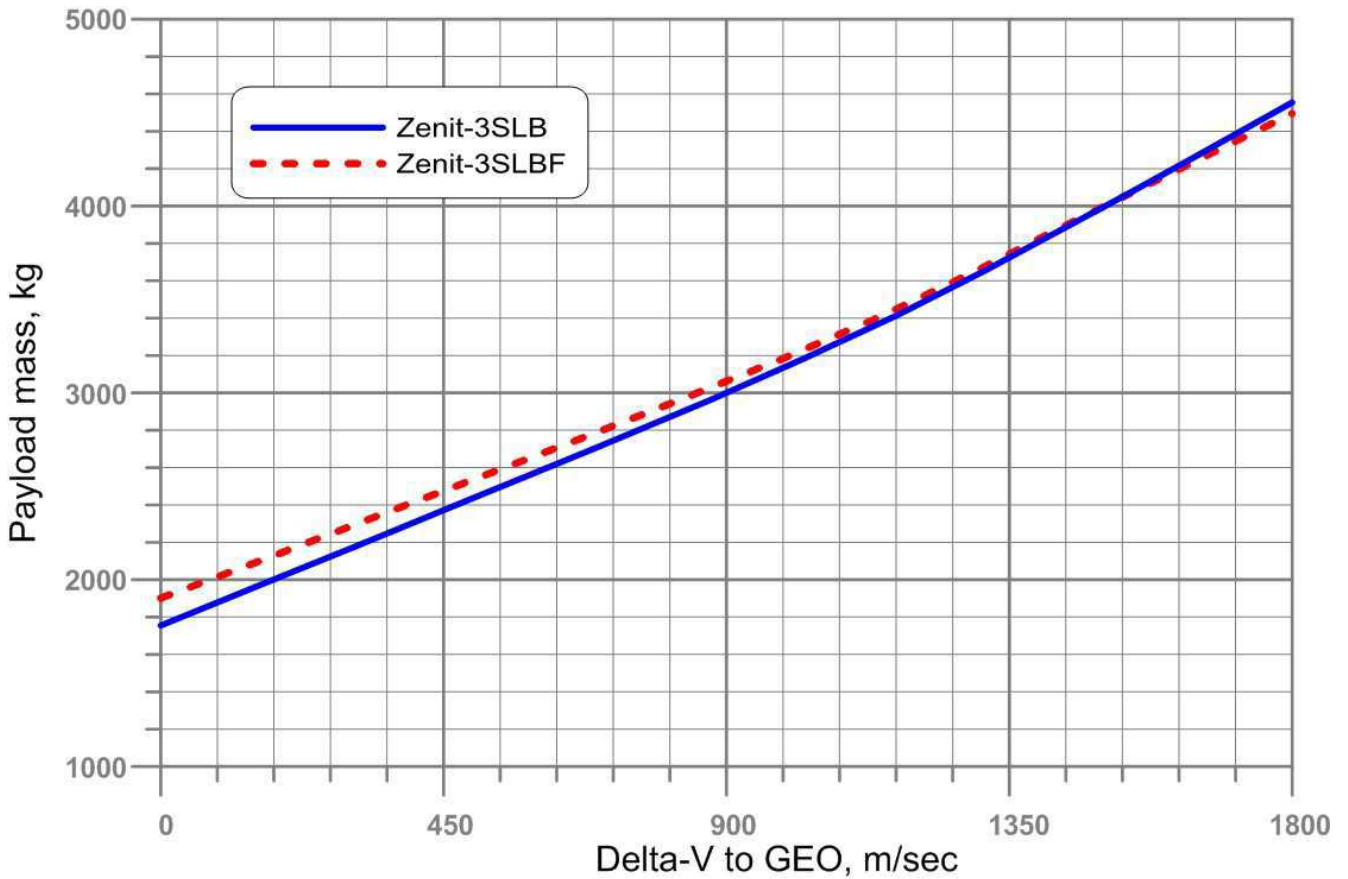

Figure. Zenit-3SLB and Zenit-3SLBF GTO payload capability

The three-stage Zenit-3SLB and Zenit-3SLBF vehicles allow SC injection into middle earth and high earth circular orbits and super-synchronous geotransfer orbits corresponding to the existing basic directions. Other inclinations for these orbits are also available. This is nominally achieved at the expense of performance reduction depending on orbit height and orbit plane change needed. Tables and the figure below depict Zenit-3SLB and Zenit-3SLBF payload capabilities for circular earth orbits and super-synchronous geotransfer orbits. In case of need for a specific ILV performance for any kind of orbit Customers are encouraged to contact the LSP.

Table. Zenit-3SLB circular orbit payload capabilities

Height, km	Payload mass, kg
5000	5000
10000	4850
20000	3720
30000	3170

Note:

- Inclination of 51,4 °
- Block DM-SLB upper stage load capability limitation is 5000 kg
- Payload mass includes adapter mass

Table. Zenit-3SLBF circular orbit payload capabilities

Height, km	Payload mass, kg
10000	4500
20000	3800
30000	3250

Note:

- Inclination of 51,4 °
- Fregat-SB upper stage load capability limitation is 4500 kg
- Payload mass includes adapter mass

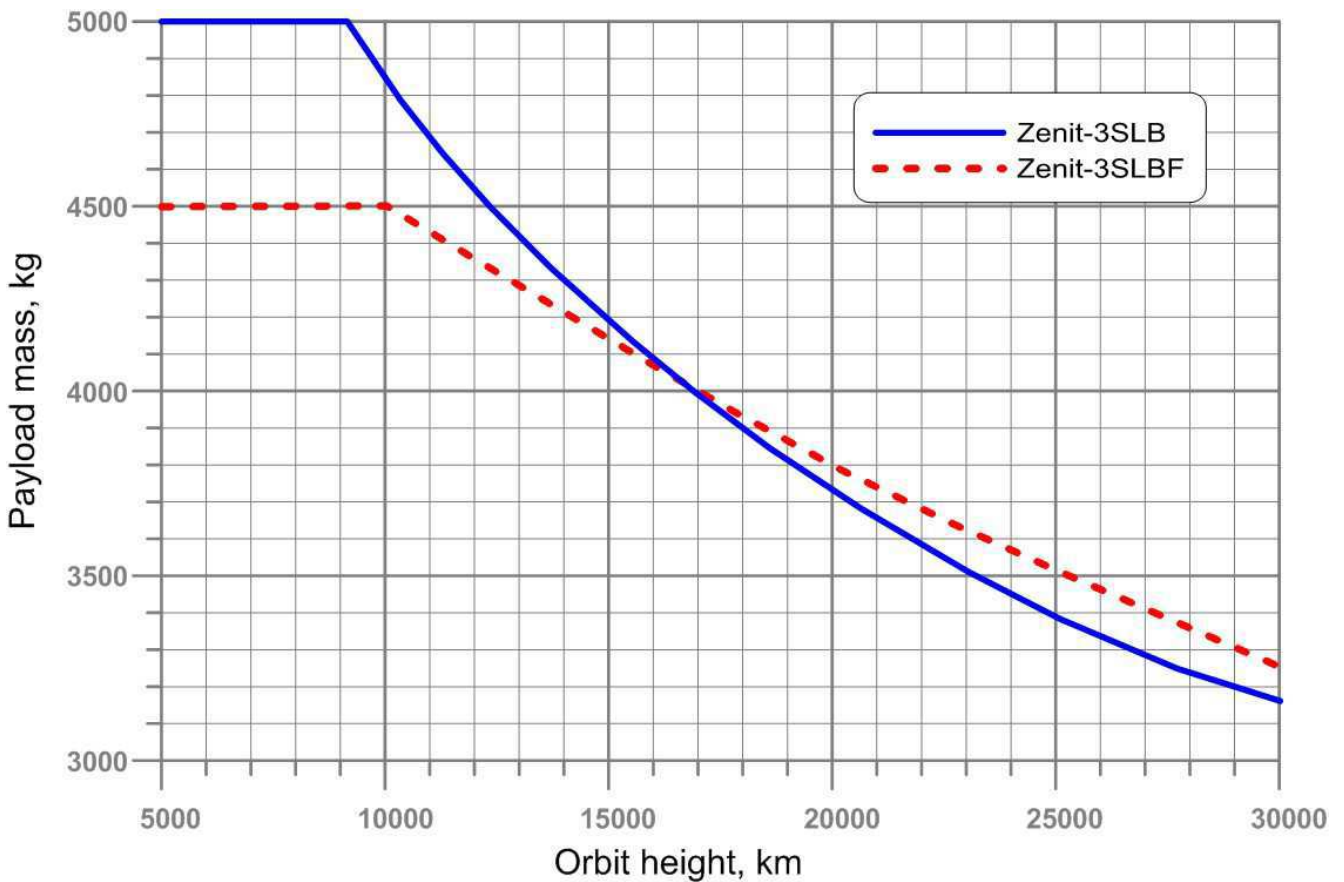

Figure. Zenit-3SLB and Zenit-3SLBF circular orbit payload capabilities

Table. Zenit-3SLB super-synchronous geotransfer orbit payload capabilities

Apogee, km	Delta-V to GEO, m/sec	Payload mass, kg
100000	1760	4830
80000	1862	4980
60000	2023	5000

Note:
 - Perigee at approximately 200 km
 - Inclination of 51,4 °
 - Block DM-SLB upper stage load capability limitation is 5000 kg
 - Payload mass includes adapter mass

Table. Zenit-3SLBF super-synchronous geotransfer orbit payload capabilities

Delta-V to GEO, m/sec	Perigee, km	Inclination, °	Payload mass, kg
1450	4143	26,0	4000
1500	3539	27,9	4080
1550	2984	29,9	4160
1600	2478	32,0	4240
1650	2018	34,2	4320
1700	1601	36,6	4410
1750	1230	39,0	4490

Note:
 - Apogee at 65000 km
 - Fregat-SB upper stage load capability limitation is 4500 kg
 - Payload mass includes adapter mass

The Land Launch three-stage Zenit-3SLB and Zenit-3SLBF vehicles allow SC injection into high-energy orbits and Earth escape trajectories. Tables and the figure below depict Zenit-3SLB and Zenit-3SLBF payload capabilities for high-energy orbits and Earth escape trajectories. Performance is shown as C_3 function (velocity-at-infinity squared).

Table. Zenit-3SLB high-energy and Earth escape payload capability

$C_3, \text{ km}^2/\text{sec}^2$	Payload mass, kg
-20	5000
-10	4620
0	3780
15	2740
30	1900

Note:
 - Inclination of 51,4 °
 - Perigee of 300 - 450 km
 - Block DM-SLB upper stage load capability limitation is 5000 kg
 - Payload mass includes adapter mass

Table. Zenit-3SLBF high-energy and Earth escape payload capability

C_3 , km ² /sec ²	Payload mass, kg
-20	4500
-10	4500
0	4200
15	3000
30	2200

Note:
 - Inclination of 51,4 °
 - Perigee of 300 - 550 km
 - Fregat-SB upper stage load capability limitation is 4500 kg
 - Payload mass includes adapter mass

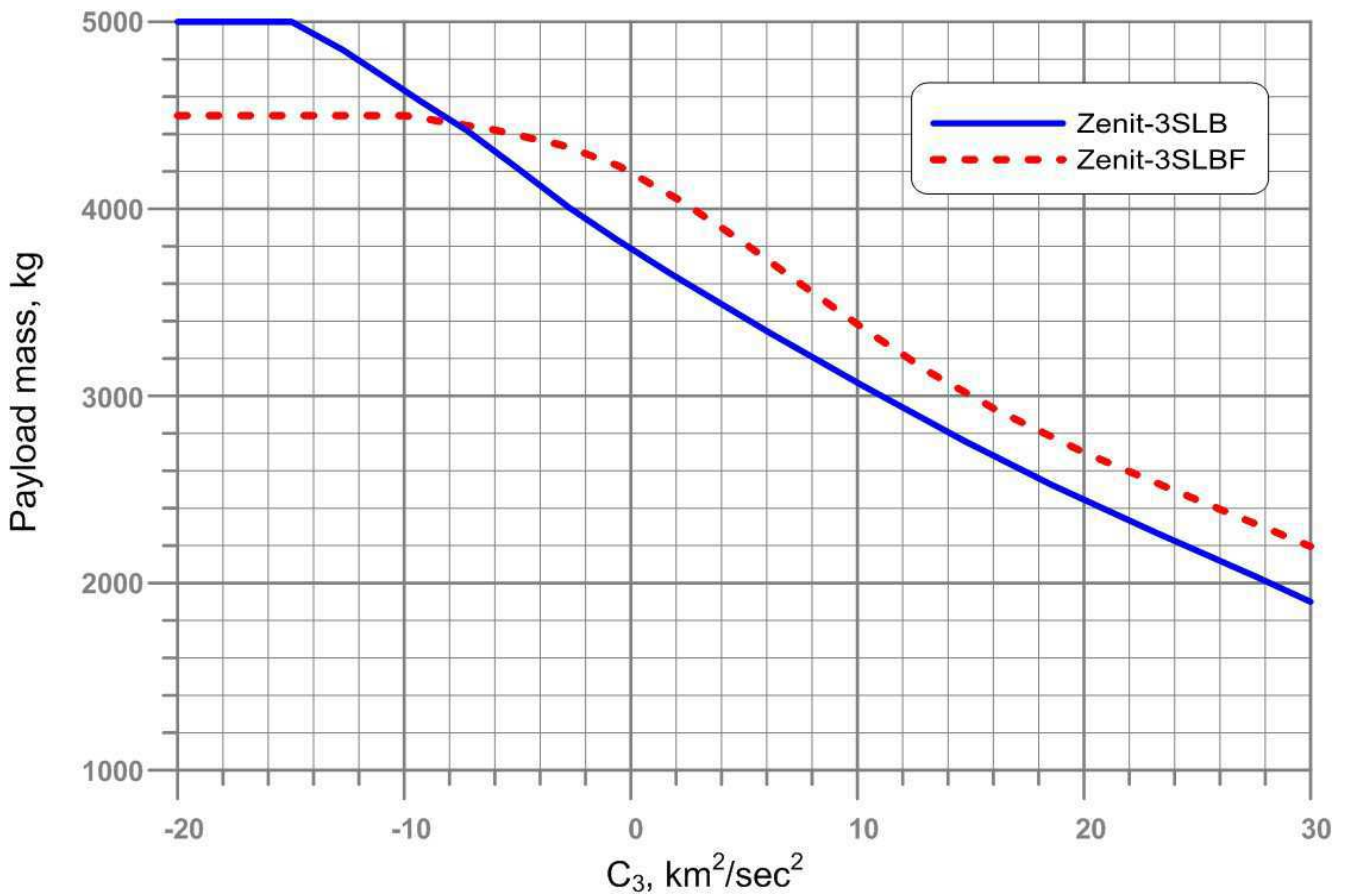

Figure. Zenit-3SLB and Zenit-3SLBF high-energy and Earth escape payload capability

Zenit-3SLB and Zenit-3SLBF generic ascent trajectory

The example below is attributable to a Zenit-3SLB GTO mission for a SC weighting 3600 kg. Nuances attributable to Zenit-3SLBF mission will be noted along the description.

For such missions, the Zenit-3SLB uses the same basic launch direction (inclination $i = 51,4^\circ$) and the assigned drop zone and insertion scheme with

three Block DM-SLB upper stage burns (see figure below). As to Zenit-3SLBF missions for a spacecraft weighting up to 3000 kg Fregat-SB upper stage ignites three times whereas for a spacecraft weighting over 3000 kg Fregat-SB upper stage employs so called 'extra-burn' scheme with four burns.

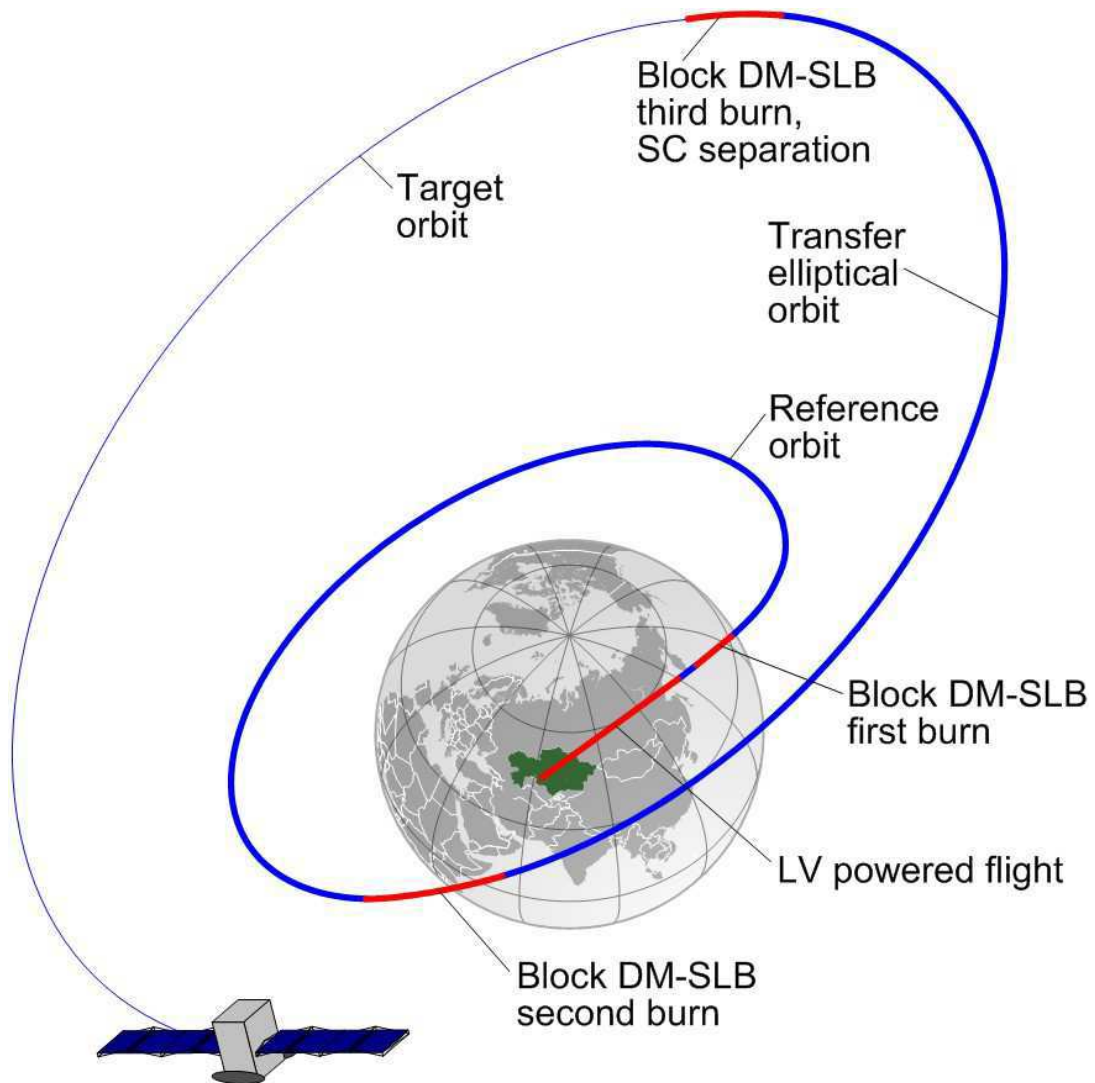

Figure. Zenit-3SLB GTO mission

The Zenit first stage powered flight provides the thrust for the first 149 seconds of flight. The roll maneuver begins at 10 seconds after launch. During the final seconds of its burn the engine is throttled to limit the maximum axial acceleration. Throughout this phase of the mission, the TMI is received by ground control stations.

The Zenit second stage vernier engine ignites prior to first stage separation. Once first and second stages are separated, the first stage SRBs fire and second stage main engine ignition occurs. The main engine and vernier engines continue to operate in tandem for the next five minutes of flight. After second stage main engine cut-off, the vernier engines continue to function for approximately 75 seconds to provide attitude control up through second/upper

stage separation. Throughout this phase of the mission, the TMI is received by ground control stations.

Payload fairing jettison occurs at approximately 320 seconds supporting the free molecular heating rate of 500 W/m^2 and hitting the assigned drop zone.

The duration and number of powered and coast flights of an upper stage depend on SC mass and type of upper stage - Block DM-SLB or Fregat-SB. Throughout upper stage flight, the TMI is received by ground control stations either in direct transmission mode or in playback mode. Whenever out of visibility zones all information related to the onboard systems status is recorded on the onboard memory unit and is played back to the ground whenever is visible for ground control stations.

For the example described herein, three Block DM-SLB ME burns are employed. At approximately 65 to 90 seconds after ILV second stage main engine shutdown and an altitude of 180 to 400 km, the second stage vernier engines shut down. This event is quickly followed by second/upper stage separation and the subsequent jettison of the middle adapter surrounding Block DM-SLB (Fregat-SB does not have a middle adapter). Block DM-SLB first burn occurs at approximately 10 sec after separation from the ILV second stage and lasts approximately 200 sec. Block DM-SLB ME first burn establishes a stable reference orbit (for Fregat-SB option with SC weighting less than 3000 kg it is the LV that brings both Fregat-SB and SC to a reference orbit). Afterwards, coast maneuvering takes place; attitude control along a reference orbit is supported by attitude and ignition support system.

The Block DM-SLB second burn occurs at the first ascending node of a reference orbit to transfer to an intermediate elliptical orbit with a geostationary or super-synchronous apogee. Ignition starts at approximately 75 minutes after launch and typically continues for approximately 6 minutes (for Fregat-SB option with SC weighting over 3000 kg the second burn lasts until JTB propellant is burned to depletion, JTB are jettisoned, Fregat-SB ME third burn occurs at the ascending node of the intermediate elliptical orbit after a two-hour coast).

After approximately 5 hours of flight Block DM-SLB reaches GTO apogee, where a ME third burn is performed to optimize a delivery orbit by raising perigee and reducing orbit plane inclination thus forming a delivery orbit. Table below provides a typical sequence of events for a three-burn Zenit-3SLB mission to GTO for a 3600 kg payload. The generic three-burn Zenit-3SLB mission to GTO makes 6,6 hours. The generic four-burn Zenit-3SLBF mission to GTO makes 8,5 hours.

Table. Three-burn Zenit-3SLB GTO generic flight timeline

Время, с	Событие миссии
0	Engine ignition
3,9	Lift-off
12	Begin pitch over
14	Roll to launch azimuth
59	Maximal dynamic pressure
115	Maximal axial acceleration
from 115 up to 132	First stage main engine throttling
144	Second stage vernier engine ignition
147	First stage main engine cut-off
149	First stage separation
154	Second stage main engine ignition
320	Fairing jettison
432	Second stage main engine cut-off
507	Second stage vernier engine cut-off
508	Second stage separation
509	Block DM-SLB middle adapter jettison
517	Block DM-SLB main engine ignition 1
707	Block DM-SLB main engine cut-off (MECO) 1
4534	Block DM-SLB main engine ignition 2
4864	Block DM-SLB main engine cut-off (MECO) 2
23562	Block DM-SLB main engine ignition 3
23631	Block DM-SLB main engine cut-off (MECO) 3
Mission-specific	SC separation

The figure below presents an approximate SC ground track for a generic three-burn Zenit-3SLB GTO mission.

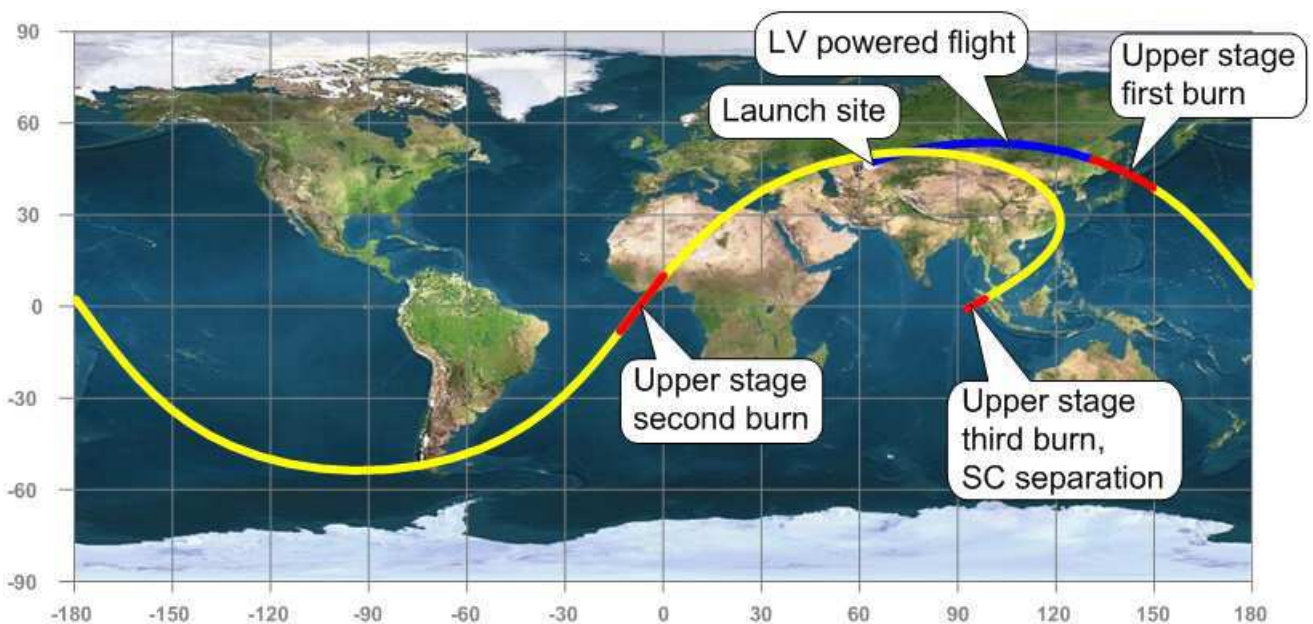

Figure. Generic Zenit-3SLB GTO mission ground track

During coast phases the Block DM-SLB and Fregat-SB control systems can provide three axes pointing with accuracy up to ± 3 degree in all three axes. The control system of Block DM-SLB can provide continuous roll along the longitudinal axis or one of the lateral axes at a rate up to 5 degrees per second. The control system of Fregat-SB can provide continuous roll along the longitudinal axis or one of the lateral axes at a rate up to 1 degree per second. Attitude mode and parameters shall be concurred with Customers

Zenit-3SLB and Zenit-3SLBF separation conditions and injection accuracy

For a generic case, SC separation occurs 10 - 15 minutes after upper stage last MECO. This allows for reorientation to the required spacecraft separation attitude. SC motion parameters after separation from an upper stage are to be concurred with Customers. Attitude accuracy and relative and angular velocity values dramatically depend on SC mass and inertia properties and shall be specified during the PIMA phase.

After SC separation, an upper stage performs a collision and contamination avoidance maneuver (CCAM), which prevents future contact with the spacecraft. The timing of this maneuver is mission-specific.

The state vector during SC separation may be provided to Customers 35 minutes after receiving TMI in direct transmission mode. Whenever there is no direct link, the state vector may be provided to Customers 50 minutes after the TMI playback is complete. The format of the state vector shall be concurred with Customers.

The following table depicts SC insertion accuracy (3σ) using three-stage Land Launch vehicle into generic orbits.

Table. SC insertion accuracy using three-stage Land Launch vehicle into generic orbits

Orbit parameter	Circular (1000 km x 1000 km, $i = 51,4^\circ$)	GTO (4000 km x 35786 km, $i = 23^\circ$)	GEO
Orbit height, km	± 25	-	$\pm 200 (\pm 190)$
Perigee, km	-	$\pm 40 (\pm 50)$	-
Apogee, km	-	$\pm 100 (\pm 90)$	-
Inclination, $^\circ$	$\pm 0,06$	$\pm 0,1$	$\pm 0,2$
Longitude of ascending node, $^\circ$	$\pm 0,2$	$\pm 0,3 (\pm 0,5)$	-
Argument of perigee, $^\circ$	-	$\pm 0,2 (\pm 0,4)$	-
Period, sec	± 45	-	$\pm 450 (\pm 565)$
Note: (...) - Fregat-SB value			

INTERFACES

This section describes mechanical, electrical and radio frequency (RF) interfaces between a spacecraft and the Land Launch system.

Mechanical interfaces

This section describes payload envelopes inside ILV fairings, access hatches, Customer logo and SC adapters.

Payload envelope under fairing

The payload envelope inside a fairing is the maximum allowable dimensions that shall accommodate a spacecraft. This includes manufacturing tolerances, thermal insulation and its buckling.

The payload static envelope accounts for AU manufacturing and assembly tolerances, AU dynamic displacements due to deformations at all phases of operations as well as thermal deformations. Dynamic displacements are defined in the course of coupled loads analysis. These deformations will be specified more exactly depending on SC natural frequencies and are subject to confirmation in the course of the coupled loads analysis. Local spacecraft protrusions beyond the static payload envelope shall be allowed under a separate concurrence with the LSP.

The following figures depict payload envelopes inside fairings and a generic view of several spacecrafts attached to a dispenser inside Zenit-2SLB fairing. Also, the payload envelope 3D models in Step format may be downloaded at www.landlaunch.ru/ll_3d_zone.zip. These envelopes are simplified and may be used for preliminary assessments of SC allocation inside ILV fairings. The more detailed assessment of SC allocation inside fairings may be performed by the LSP used a 3D model provided by Customers prior to contract execution. The SC 3D model for SC allocation feasibility and for clearance analysis during PIMA activities shall be provided in Step AP203 format.

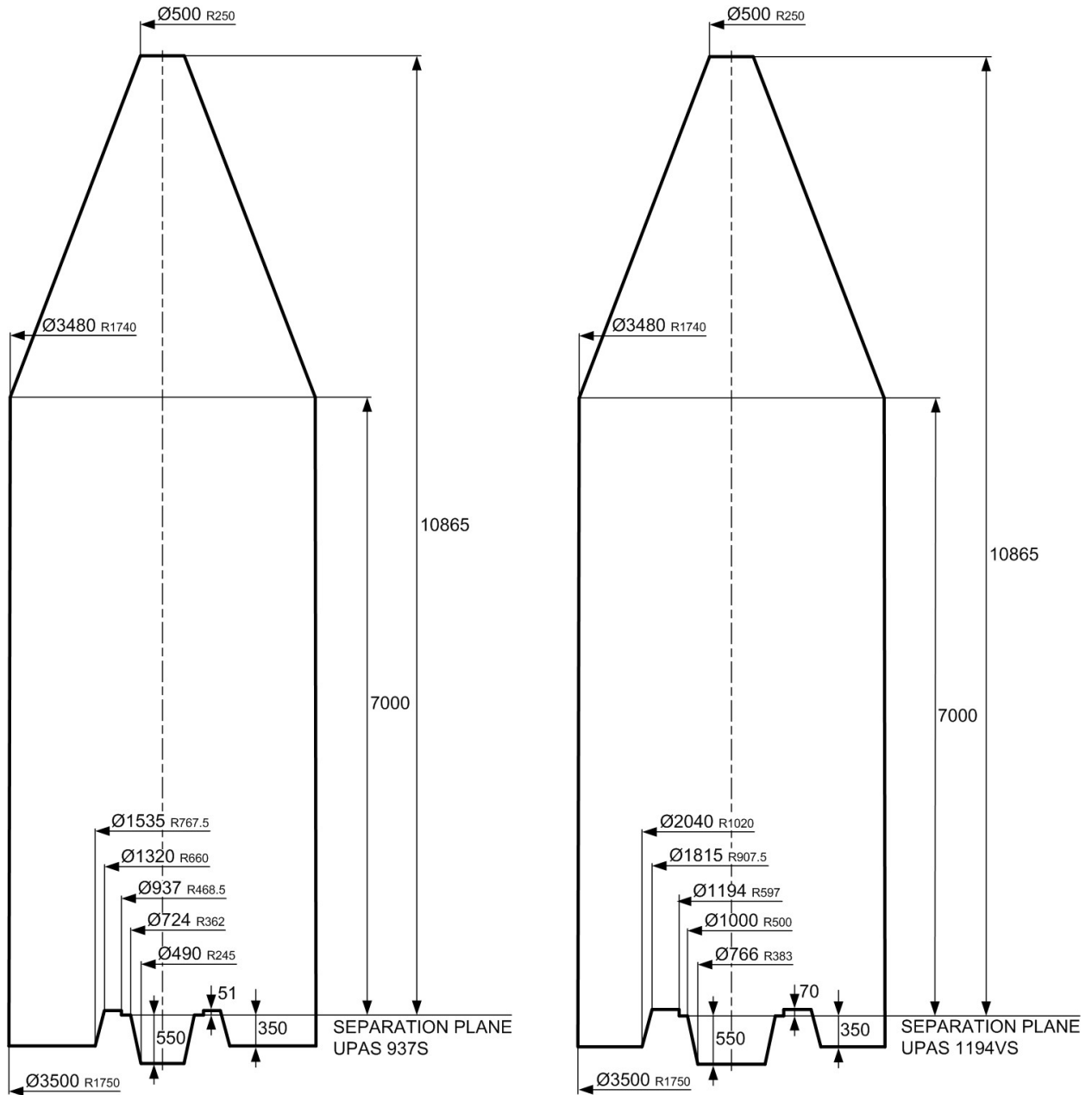

Figure. Payload static envelope for Zenit-2SLB fairing and UPAS 937S and UPAS 1194VS adapters

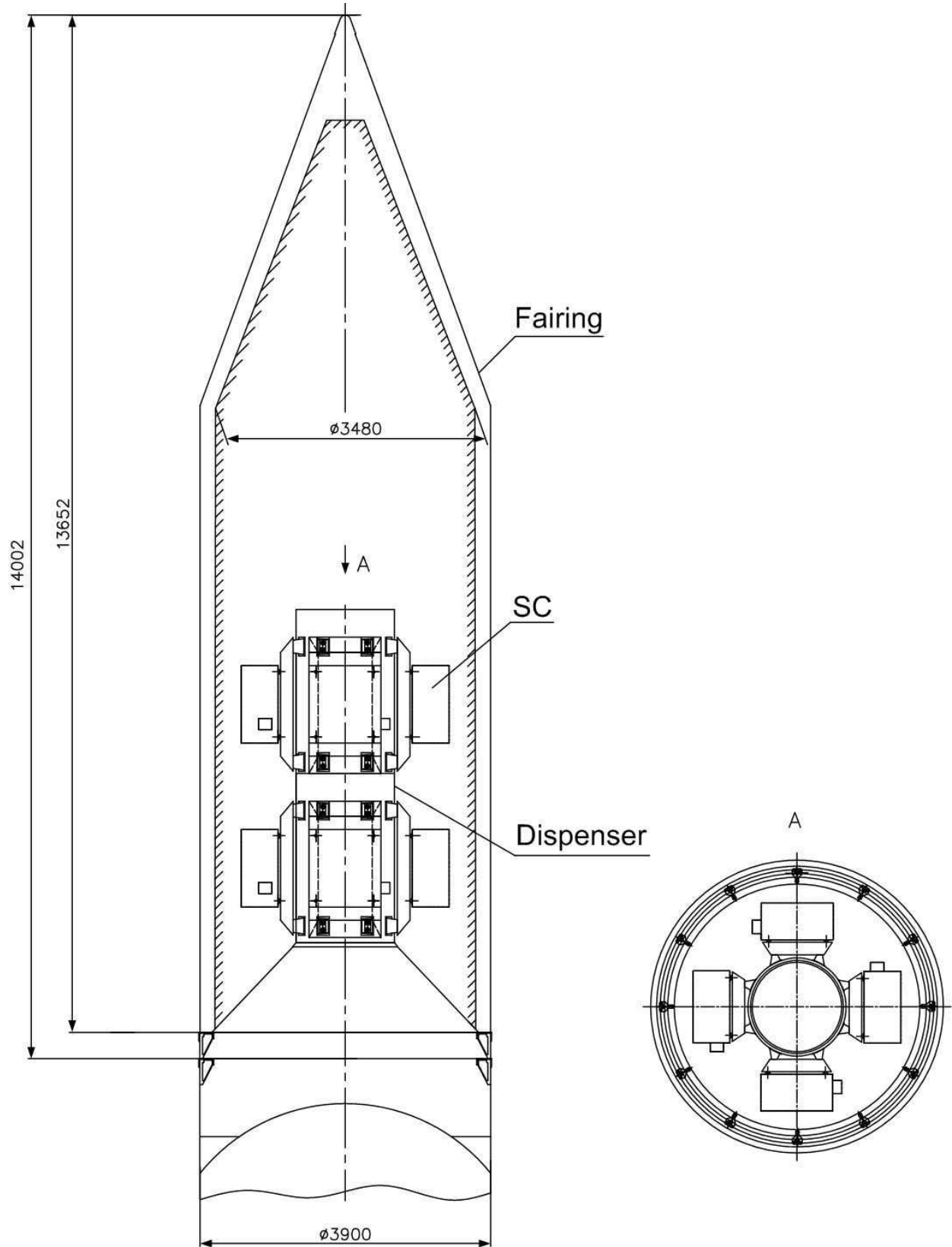

Figure. Generic view of several spacecrafts attached to a dispenser inside Zenit-2SLB fairing

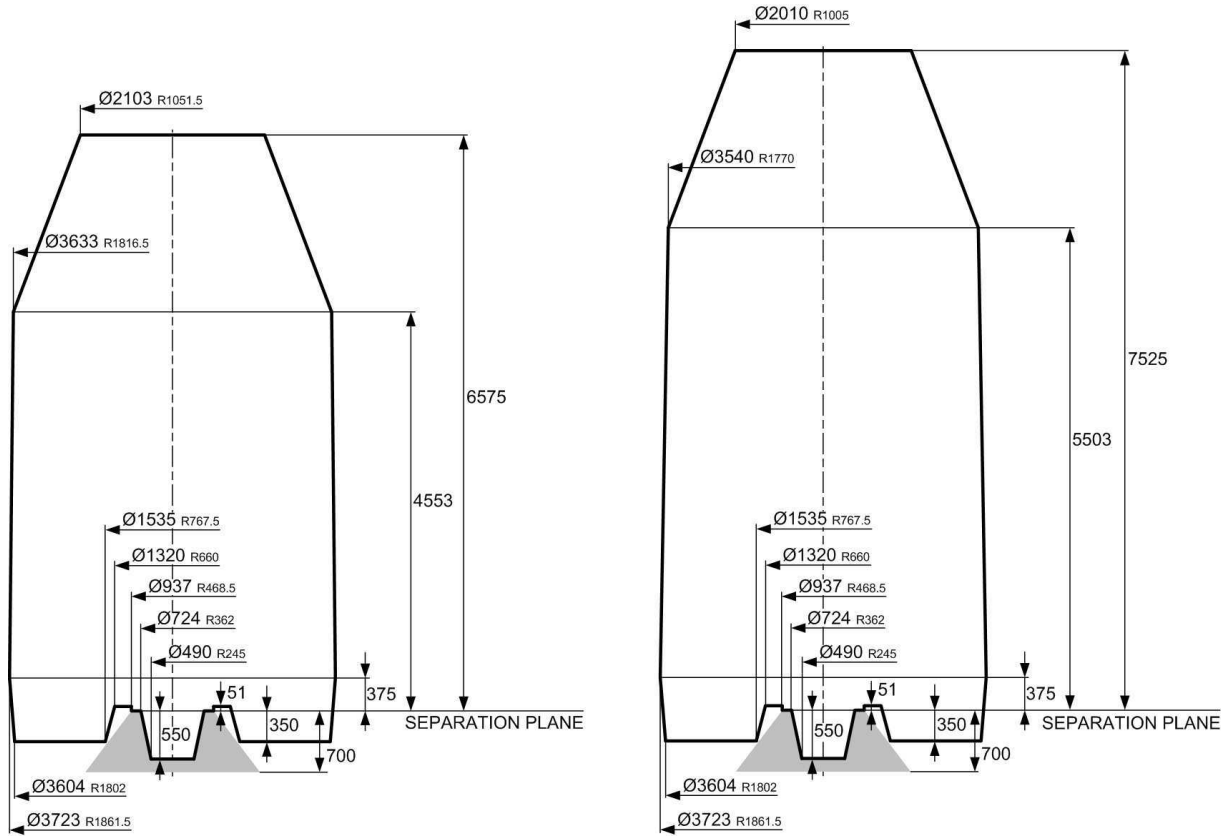

Figure. Payload static envelope for Zenit-3SLB 10,4 m and 11,35 m fairings using UPAS 937S adapter

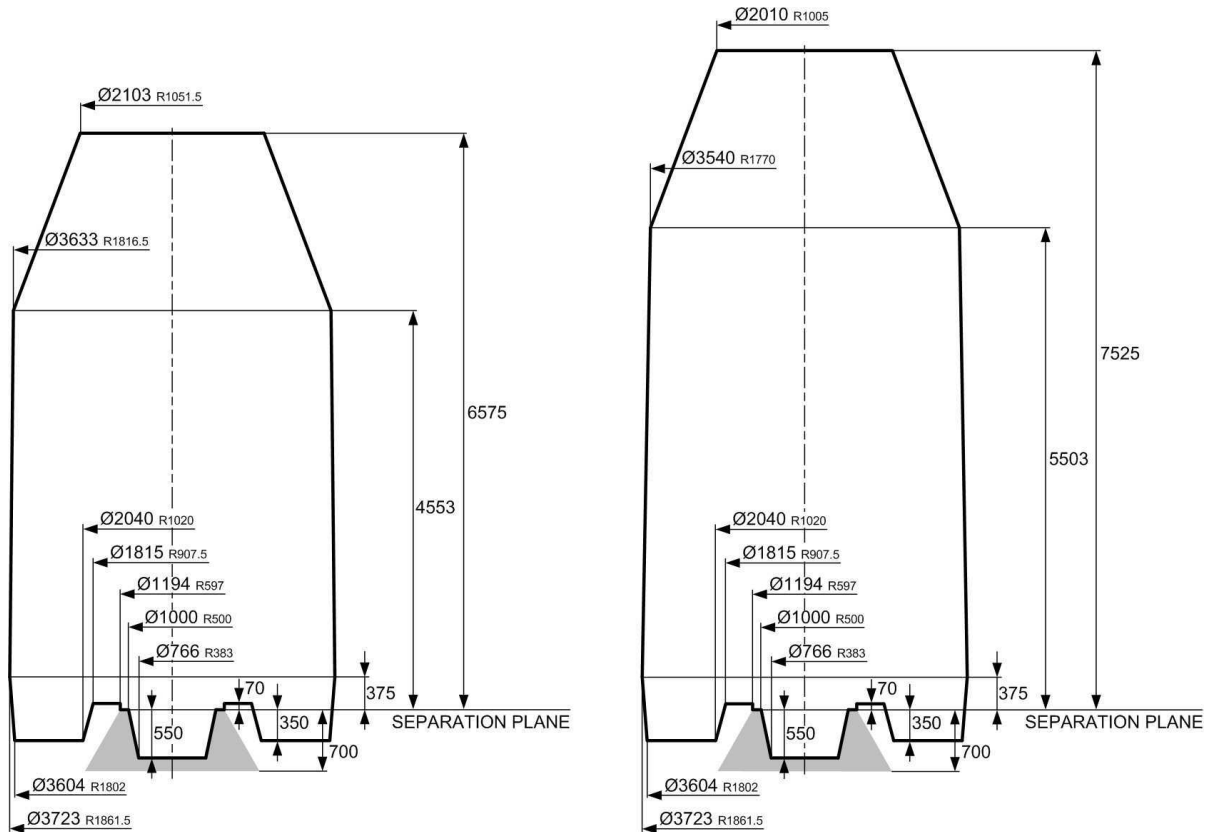

Figure. Payload static envelope for Zenit-3SLB 10,4 m and 11,35 m fairings using UPAS 1194VS adapter

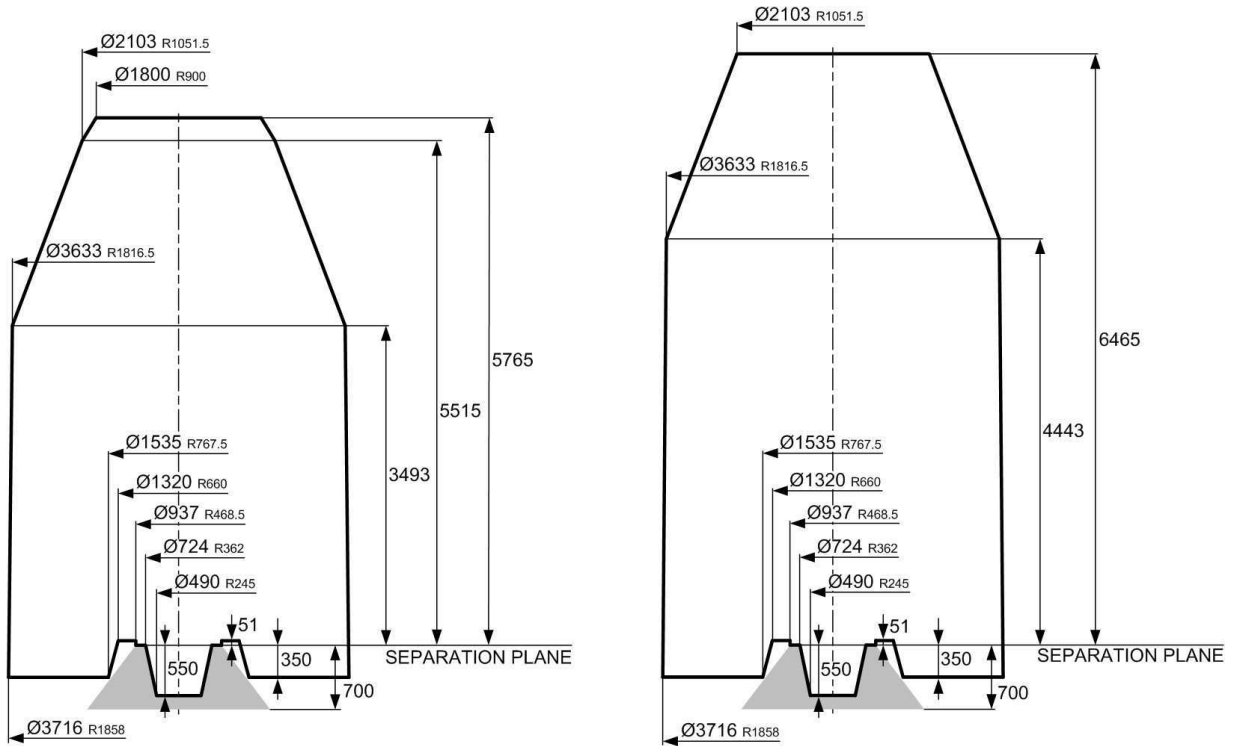

Figure. Payload static envelope for Zenit-3SLBF 10,4 m and 11,35 m fairings using UPAS 937S adapter

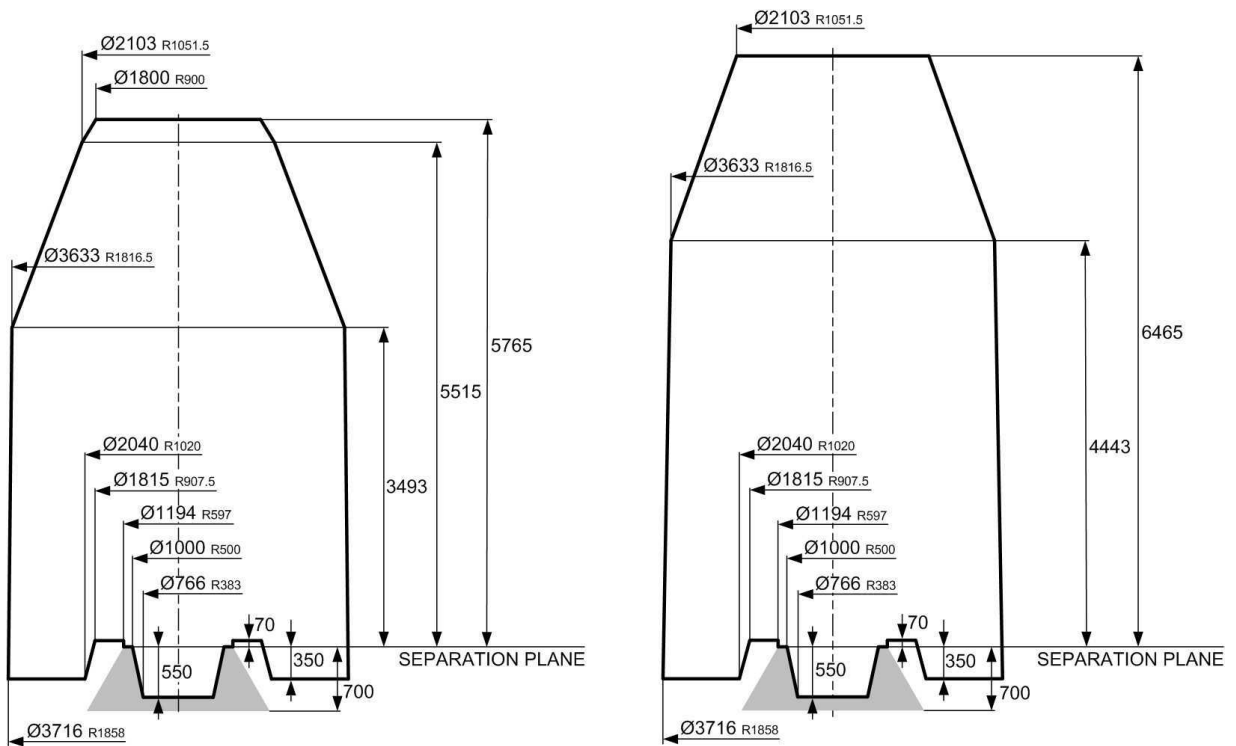

Figure. Payload static envelope for Zenit-3SLBF 10,4 m and 11,35 m fairings using UPAS 1194VS adapter

Access hatches

Land Launch fairings may accommodate one or two SC access hatches. Customers may access their encapsulated SC at the AUPF and at LV/ILV processing facility. The maximum possible hatch dimensions are 460x480 mm. The need for access hatches, their location and dimensions shall be defined by Customers and the LSP.

Customer logo

The outer surface of Land Launch fairings provides space for a Customer logo. Customers shall provide their logo in soft copy. Logos will be manufactured by the LSP. The maximum possible logo dimensions are 3500x3500 mm.

SC adapter

SC is mounted on top of an adapter that provides electrical and mechanical interfaces. A spacecraft adapter includes separation system and SC environment monitoring system.

Land Launch employs RUAG's carbon fiber reinforced plastic adapters with 937 mm interface (UPAS 937S) and 1194 mm interface (UPAS 1194VS), both 700 mm high. The UPAS 937S adapter weights nearly 75 kg, and the UPAS 1194VS adapter weights nearly 81 kg. It is also possible using adapters with other interfaces. For a cluster launch the LSP can provide a dispenser.

The UPAS 937S and UPAS 1194VS adapters employ SC separation scheme based on clamp band type attachment which includes fast-response low-shock clamp band opening device (CBOD) developed by RUAG. For the UPAS 937S adapter the nominal clamp band tension is 30 kN, maximal clamp band tension is 37 kN. For the UPAS 1194VS adapter the nominal clamp band tension is 40 kN with maximal clamp band tension of 47 kN. During the PIMA activities the clamp band tension may be specified for a specific spacecraft. The relative SC separation velocity is supported by a set of separation spring set. The adapters are not sources of mechanical or outgassing contamination during SC separation.

The following figures show UPAS 937S and UPAS 1194VS adapters and SC mass vs. center of gravity (CG) graphs. Adapter shock responses are shown in the Spacecraft Environments section.

SC adapter (SCA) to SC matchmate test is possible, if required. Usually, for a first spacecraft of a kind the matchmate tests are needed for SC flight model and an adapter. Such tests are usually performed at the SC manufacturing facility. The tests include mechanical and electrical interfaces mating and checks. The tests may also include firing/drop test to define shock environments at SC interface. For recurrent missions of a SC of the same type the full-scale

tests are usually redundant. In such case a Touch'n'Go test is possible after a spacecraft arrives to Baikonur.

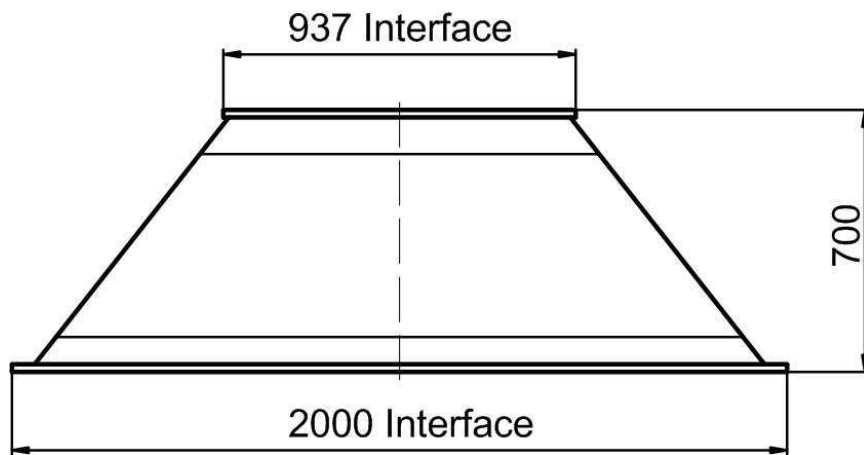

Figure. UPAS 937S adapter

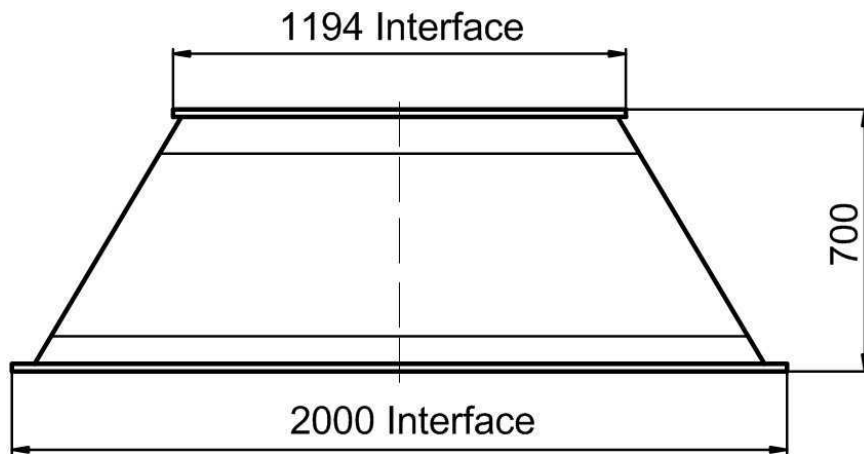

Figure. UPAS 1194VS adapter

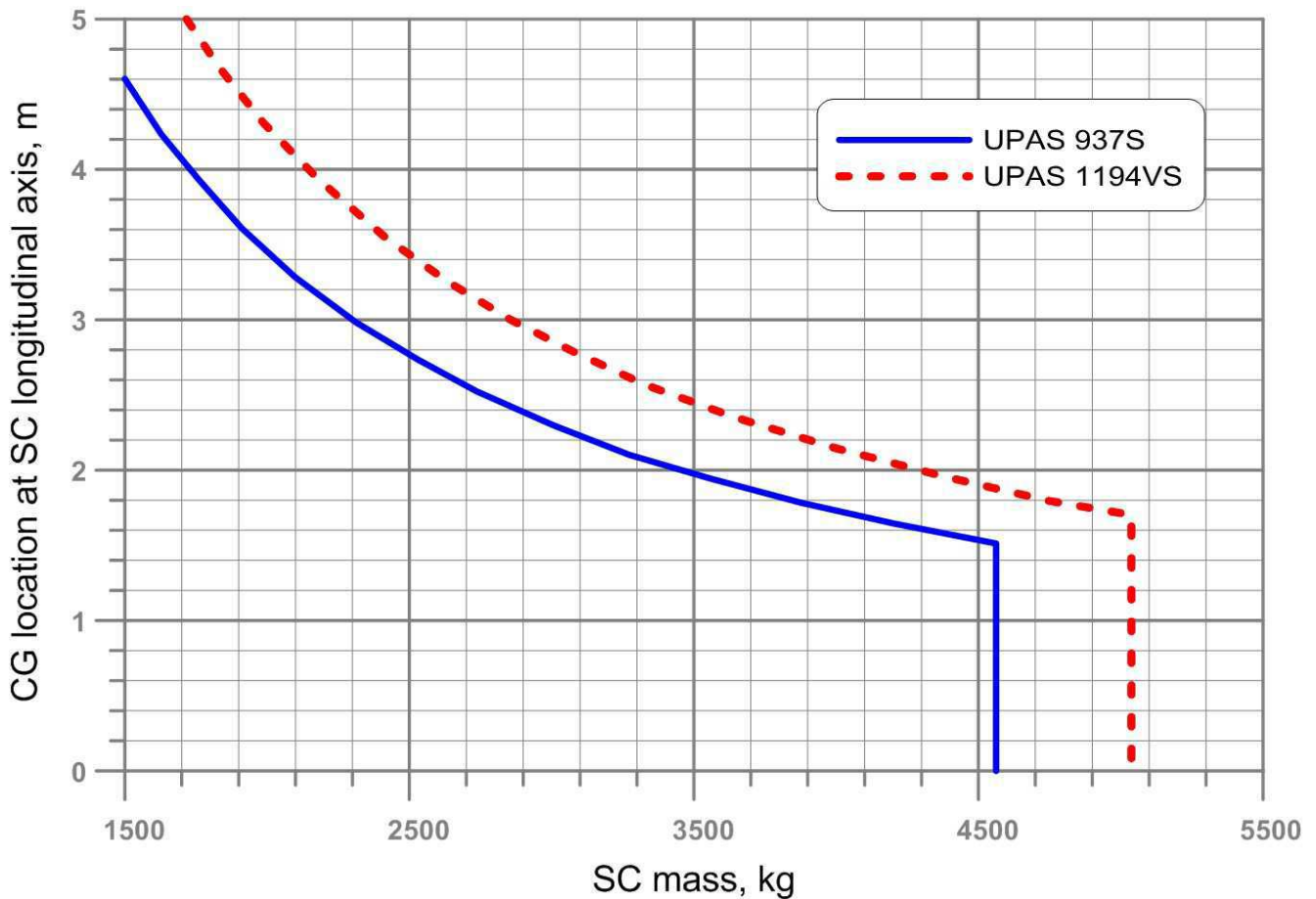

Figure. UPAS 937S and UPAS 1194VS load capability

Electrical and radio frequency interfaces

This section describes the following SC and GSE interfaces used throughout the launch campaign:

- SC-to-GSE hard-line link (SCA harness),
- In-flight electrical interfaces (commands, measurement and telemetry),
- Electrical GSE links,
- Electrical power for GSE,
- Static electricity protection (bonding and grounding), lightning protection,
- RF links (radio transparent window).

SC-to-GSE hard-line link

The SC-to-GSE hard-line link in launch configuration at the launch pad is provided by cables routed via ILV (SCA, upper stage, LV), cable mast, launch complex unified harness and SC GSE connection cables. As an example, the figure below shows the generic configuration of the overall electrical scheme for Zenit-3SLB.

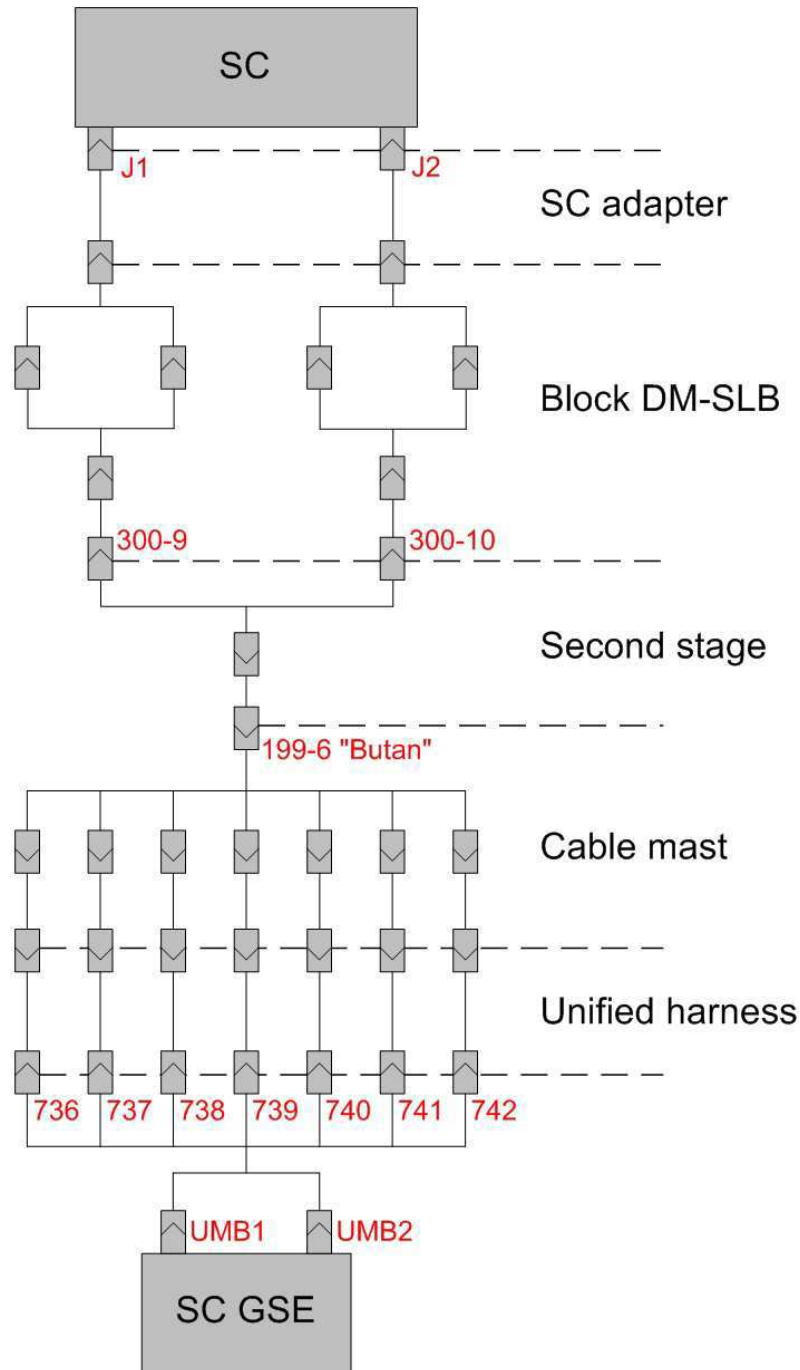

Figure. Generic configuration of the overall electrical scheme

The total length of cables of this link from SC umbilical connectors J1 and J2 at SC/SCA interface down to SC GSE UMB1 and UMB2 electrical connectors makes nearly 97 meters.

This schematic configuration for Zenit-3SLB has the maximal number of intermediate electric connections and the longest cable length as compared with similar diagrams for Zenit-2SLB and Zenit-3SLBF.

The direct SC-to-GSE hard-line link at other facilities is done:

- Using Customer-supplied cables no less than 35 meters long at the PPF and HPF,

- Using LSP-provided cables during combined operations at AUPF, LV/ILV processing facilities and in the course of potential Touch'n'Go, and using Customer-supplied SC GSE cables for connecting to the unified harness (from UMB1 and UMB2 to 700 series connectors).

Customers shall supply SCA umbilical counterparts to the LSP. The LSP shall supply 700 series connector counterparts. As an optional service, the LSP can manufacture cables from UMB1 and UMB2 to 700 series connectors. In the course of PIMA a detailed SC-to-GSE electrical diagram will be developed and all details related to umbilical connector interfaces will be finalized.

The total of 200 SC umbilical circuit wires are laid via LV and upper stage. Their function and basic limitations are shown in the table below.

Table. SC-to-GSE transit circuit parameters

Function	Current, number and type of circuits
Signal	Up to 40 twisted shielded pairs, each at 250 mA at 50 VAC or 100 VDC
Power (SC power and battery charging)	Up to 120 single wires up to 70 A at 110 VDC
Note: Adapter umbilical connector circuits may accommodate electrical jumpers (separation loops, SC pyro protection prior to separation, etc.), if required by Customers	

Each twisted pair of signal wires is enclosed inside its own shield. Shields of all twisted pairs are connected among each other and are grounded. SCA power single wires are not twisted and usually are not shielded. For power single wires laid via upper stage the shield is the upper stage metal body and vacuum thermal insulation foil, and for power single wires laid via the launch vehicle is the metal cable tray. For the purpose of reducing the overall electrical resistance one pin of umbilical connectors may be soldered to several wires. Out of 120 single power wires four are used for electric connector mating check and two more are connected to the ILV body. The umbilical connections described above may be used by Customers at every step of operations at Baikonure.

In-flight commands, measurement and telemetry

During the flight an ILV can provide the following signals to a spacecraft:

- Lift-off,
- Fairing jettison,
- Ready for SC separation,
- SC separation,
- Two main auxiliary commands,
- Two back-up commands.

These commands are supplied via umbilical connectors via power wires (two wires per command). These commands are issued via dry loop, i.e. there are no SC-to-ILV electrical links via power circuits. The typical parameters of these commands are shown in the table below.

Table. Parameters of commands being issued by ILV to a spacecraft

Command parameter	Value
Time when issued	Any time between launch and SC separation
Issuing accuracy	±35 msec
Signal duration	64±8 msec
Current	0,01 to 1,0 A
Voltage	Up to 34 V

ILV provides signaling and power supply for SC separation system initiation in a pre-specified point during the flight. No ILV signal circuits or power circuits go beyond the SC separation plane.

In order to record longitudinal and lateral loads and SC separation event the SCA accommodates monitoring equipment. Its recorded data is transmitted to ground tracking stations via telemetry system. Also, acoustic loads data, fairing inner surface temperature, pressure decay rate, low-frequency vibration data, high-frequency vibration data and shock environment are also transmitted. Respective telemetry sensors are located inside the AU and on the SCA.

Electrical GSE links

Communication links between electrical GSE racks and electrical GSE terminals (computers) located in control rooms (at PPF, HPF, AUPF, LV/ILV processing facilities, launch complex) are supported by the following stationary links:

- Multiplex fiber optic cable 62,5/125 mkm with eight independent lines and ST interface,
- Two independent Ethernet lines, category 5 and RJ-45 interface.

Electrical power for GSE

Electrical power supply for Customer's GSE may be provided from both uninterruptible power supply source and from the power utility network.

The uninterruptible power supply for Customer's GSE at the PPF, AUPF, HPF, LV/ILV processing facility and the launch complex is provided from the main power supply source (power utility) together with uninterruptible supply source

UPS-50Hz or UPS-60Hz. These sources include: diesel generator unit uninterruptible power supply source with block of accumulator batteries. UPS-60Hz additionally includes a transformer unit.

UPS-50Hz and UPS-60Hz are intended for uninterruptible power supply to power consumers without sine voltage rupture. In case of power utility breakdown an automatic back-up unit turns on and a diesel generator unit enables. During diesel generator unit warm-up the SC GSE power is supplied with no sine voltage rupture due to UPS operation. Time of UPS autonomous operation makes 10 minutes at maximal capacity. UPS-50Hz and UPS-60Hz parameters are shown in the table below. Customers are provided with two rooms at the launch complex: one room in the bunker for GSE and personnel allocation, the other one in the catacombs under the launch pad for SC GSE allocation.

Table. SC GSE uninterruptible power supply system output

Location	UPS-50Hz and UPS-60Hz power output	
	U ~ 380/220 V ± 5 % f ~ 50 Hz ± 1 %	U ~ 208/120 V ± 5 % f ~ 60 Hz ± 1 %
PPF, AUPF	120 kVA	80 kVA
HPF	80 kVA	80 kVA
LV/ILV processing facility	20 kVA*	20 kVA*
LC bunker	20 kVA*	20 kVA*
SC GSE room in the catacombs at the LC	20 kVA*	20 kVA*
Note: * - uninterruptible power supply system output increase up to 40 kVA is possible		

SC GSE connection to PPF, AUPF, HPF, LV/ILV processing facility and at the LC is done using standard three-phase or one-phase outlets, SC GSE power cords shall be provided by Customers.

Types of available outlets for U ~ 380/220 V, f ~ 50 Hz power:

- Standard five-pin three-phase European sockets CEE, 400 V, 32 A per phase, 3P+N+PE, 50/60 Hz,
- Standard three-pin one-phase European sockets.

Types of available outlets for U ~ 208/120 V, f ~ 60 Hz power:

- Standard five-pin three-phase sockets NEMA 1/21-30,
- Standard five-pin three-phase sockets Grouse-Hinds p/n AR 1041,
- Standard double-sided three-pin one-phase sockets NEMA 5-20R.

Static electricity protection, lightning protection

ILV protection from static electricity is being done as per existing normative and technical documentation. Design, technical and operational documentation includes means necessary for bonding and grounding that are adhered to in the course of both ILV components production and ground equipment at all processing areas.

The bonding resistance across the SC-to-SCA is less than 10 milliohms at a current less than 10 mA. Resistance between the SCA and the ILV is less than 2 milliohms at a current less than 10 mA. Prior to launch, the ILV is connected to ground with resistance no more than 100 milliohms at a current less than 200 mA.

Every Land Launch facility where a spacecraft is located or Customer GSE is used during the processing flow, provide electrically conductive surfaces (threaded studs) for connecting to facility ground. SC transit circuit cables may have grounded circuits, if required (one wire per umbilical connector). Electric connector mating shall be performed with antistatic wrist strap only.

Lightning protection throughout the launch campaign is supported at all steps of SC processing. During all kinds of SC transportation including when a SC is part of AU or ILV, two types of protective measures may be accomplished:

- Technical measures: bonding between a container with SC inside or AU or ILV and a transportation unit frame and carriages,
- Organizational measures: transportation planning during favorable weather conditions only.

The facilities where a spacecraft is being processed are equipped with effective lightning rods systems that provide protection from direct lightning strikes as well as from secondary lightning impacts and penetration of high potentials and currents into facilities via ground and underground communications. SC protection is also supported by effective lightning rods systems, at that there is an insignificant indirect impact of pulsed electromagnetic fields in case lightning strike close.

RF links, radio transparent window

The RF link is intended for command signals and telemetry on-air transmission between SC and SC GSE during operations at the AUPF and the launch complex (see figures below) and performs the following tasks:

- Receiving and transmission of command signals from SC GSE to SC,
- Receiving and transmission of telemetry signals from SC to SC GSE.

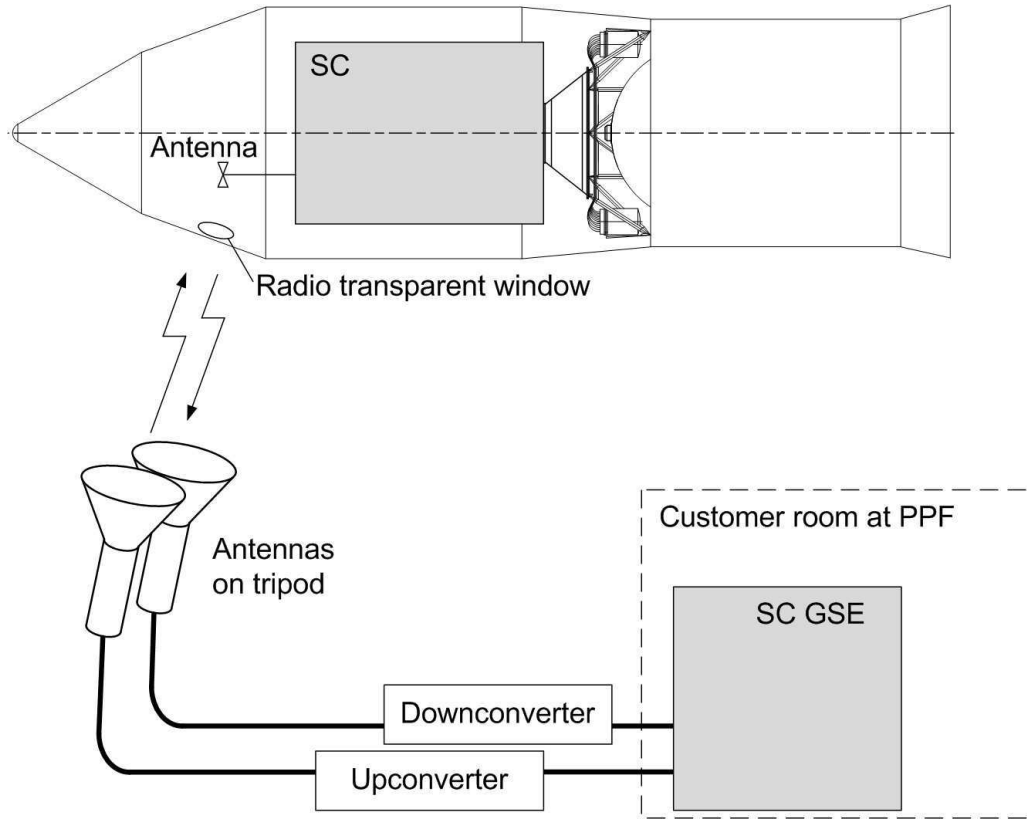

Figure. RF link at the AUPF

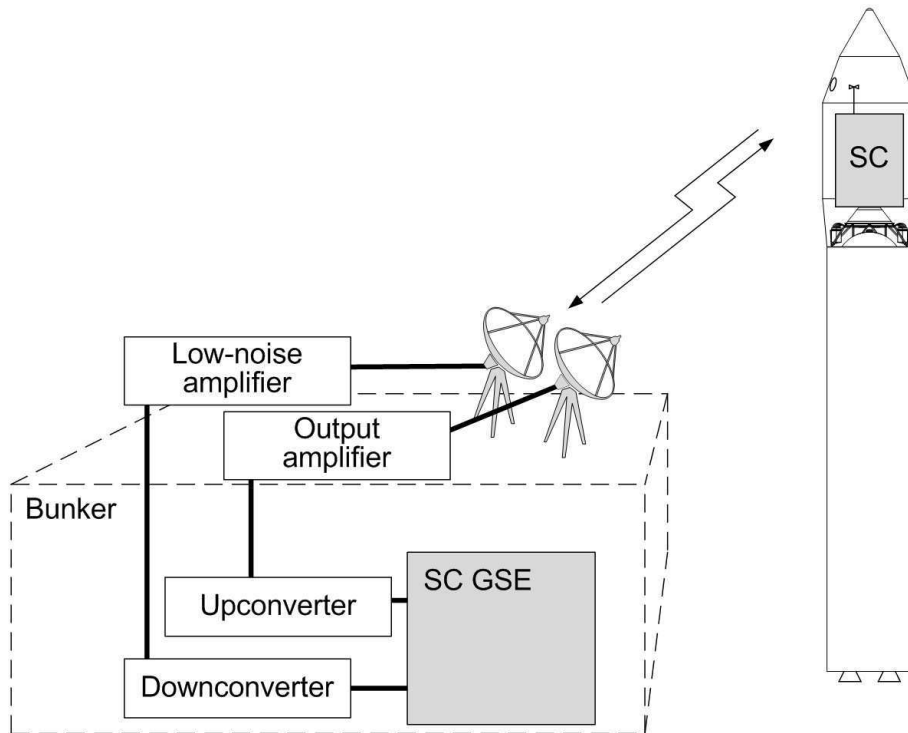

Figure. RF link at the LC

The RF link includes the following main ground equipment provided the LSP:

- Output amplifiers,
- Low-noise amplifiers,
- Block of intermediate amplifiers,

- Stationary cables,
- Coaxial connection cables,
- Portable receiving and transmitting antenna unit,
- LC stationary antenna post,
- Auxiliary equipment,
- Check-out and test equipment.

The available RF link provides signal transmission in Ku and C bands. The table below lists parameters of the available RF links.

Table. Parameters of the available RF links

Band	SC operating frequency, MHz		SC GSE operating frequency, MHz	
	Telemetry	Commands	Telemetry	Commands
Ku	11199,25	14497	11199,25	14497
	11699,5	14499	11699,5	14499
Ku with frequency shift	11449	13830,75	70	70
	11700	13832,75	70	70
	11698	14002	70	70
	11699	14004,5	70	70
C	4185	6429,5	70	70
	4186	6724,5	70	70

RF links include radio transparent window on the fairing. This is a radio transparent area on the fairing body supporting SC receivers and transmitters operation. Area location and its dimensions are defined analytically taking into account SC antennas location and their radio parameters, and are to be concurred with Customers.

SPACECRAFT ENVIRONMENTS

This section describes the major environments to which the spacecraft is exposed from the time of its arrival at Baikonur cosmodrome until its separation from the launch vehicle during flight. These environments and conditions include:

- Structural loads,
- Random vibrations,
- Shock,
- Acoustics,
- Electromagnetic radiation,
- Thermal and humidity,
- Pressure venting,
- SC contamination.

Ground environments are those environments associated with ground handling and transportation for the period from the arrival of spacecraft at Baikonur until lift-off. Flight environments are those environments affecting spacecraft for the subsequent period from lift-off command through spacecraft separation.

The coordinate system used in this section is shown in on figure below. During transfers the Longitudinal axis coincides with the motion direction, Vertical axis is perpendicular to Longitudinal axis and is pointed upright, Lateral axis supplements the coordinate system to the right-handed coordinate system. During tilting and hoisting operations axes direction coincides with allocation during the recent transportation. During lift-off and in-flight Longitudinal axis is directed towards the ILV flight direction, Vertical and Lateral axes are lateral to the flight direction.

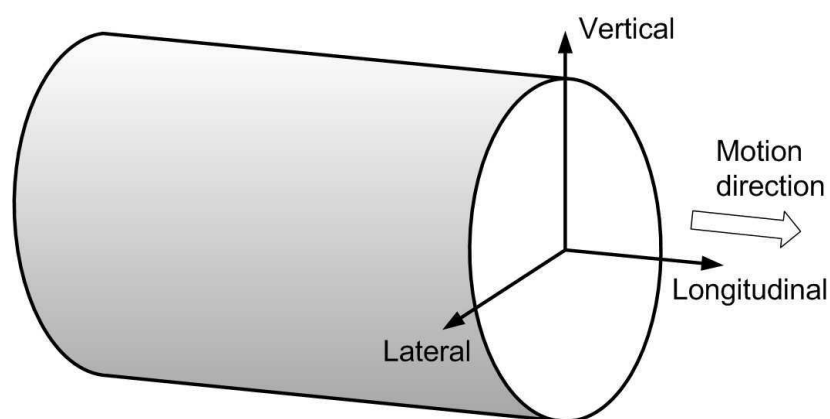

Figure. Reference coordinate system

This section uses the following definitions.

Operational load is the maximal load expected during a specific event or operation.

Design load is used for design, structure load process math modeling, SC or prototype tests and is the operational load multiplied by a safety factor.

Safety factor is a factor used for conversion of operational load into design load.

Load capacity is a minimal load on a structure that leads to destruction or failure.

Allowable load is a maximal load that a structure can sustain with no destruction or failure.

Margin of safety is an allowable load divided by design load.

Monitoring and recording of SC environments and loads shall be performed as per the mission Interface Control Document (ICD). The results shall be provided to Customers in the post-flight report. Also, records may be provided at the spot once a specific step of ground processing is complete.

SC structural loads

Description of structural loads during ground transportation, hoisting operations and in-flight is given below.

Quasi-static loads during transportation and processing

Acceleration operational values during ground transportation, hoisting operations, tilting from horizontal to vertical and back, SC processing are shown in the table below. Quasi-static accelerations are applied to the SC center of gravity and may act in Longitudinal, Vertical and Lateral directions simultaneously.

Table. Quasi-static acceleration operational values during ground operations

SC operation	Acceleration, g			Recommended safety factor
	Lon.	Ver.	Lat.	
Transportation (inside SC shipping container) from the airfield to PPF	±1,0	-1±1,0	±0,4	2,0
Transportation (inside a container) from PPF to HPF and from HPF to AUPF (see note)	±0,5	-1±0,5	±0,4	1,5
SC hoisting and tilting operations	±0,35	-1±0,2	±0,2	1,5
Hoisting operations whenever a SC is part of AU and ILV	±0,2	-1±0,2	±0,2	1,5
Transportation whenever a SC is part of AU	±0,5	-1±0,5	±0,4	1,5
Transportation whenever a SC is part of ILV	±0,35	-1±0,2	±0,2	1,5

Note:

- transportation to the HPF and back may be done in either vertical or horizontal configuration depending on the transport container being used

The maximum rate of angular acceleration (about rotation axis) during integrated launch vehicle verticalization is 0,055 rad/sec².

Quasi-static loads during lift-off and in-flight

Quasi-static load operational values during lift-off and in-flight do not exceed the values shown on the figure below. These values are applied to the SC center of gravity. Positive values of quasi-static accelerations towards Longitudinal direction are aligned with ILV flight direction.

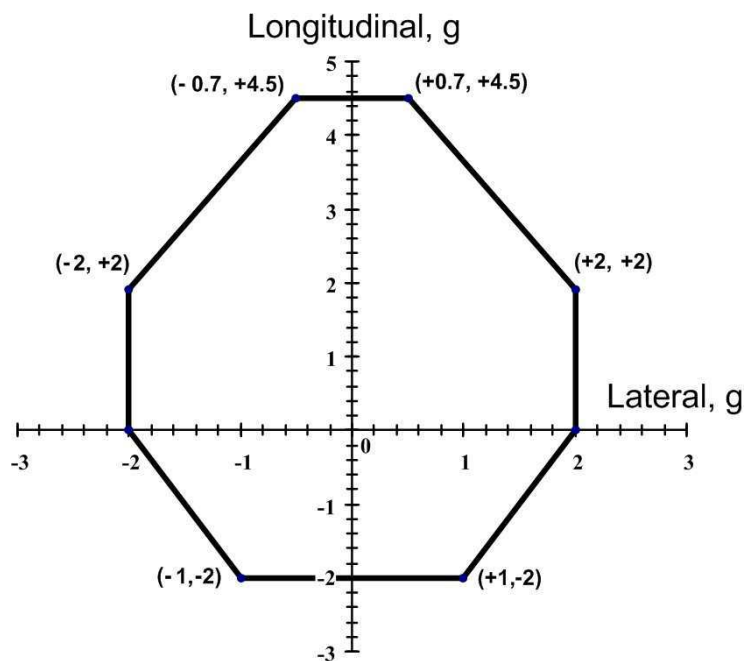

Figure. Maximal loads during lift-off and in-flight

The ability of spacecraft structure and equipment to withstand the loading events requires SC dynamic model from Customers for a Coupled Loads Analysis (CLA) to be done by the LSP for each mission during PIMA activities.

Sine vibrations in-flight

The longitudinal and lateral low-frequency sinusoidal vibration environments generated at the SC separation plane during lift-off and flight phases are within the limits defined in the following table. CLA is performed for every mission to acquire vibration impact levels at all phases of flight. Results of such analysis are used to define a maximal notch within the vibration loads spectrum that is used during SC vibration tests.

Table. Sine vibrations at SC interface

Frequency range, Hz	Amplitude, g
5-100	0,7 (0,6)
Note: - Zenit-2SLB value is bracketed	

SC dynamic model

For a CLA to be performed, Customers shall provide a SC Finite Element Model (FEM). The FEM shall be provided as follows: data format that includes Craig-Bampton mass and stiffness matrices and acceleration and displacement restitution matrices. The generated Craig-Bampton mass and stiffness matrices shall be provided in Output4 ASCII Nastran (1P,3E23.16) format in the following files: Craig-Bampton mass matrix - Craig_Bampton_M_OP4.dat, Craig-Bampton stiffness matrix - Craig_Bampton_K_OP4.dat. Acceleration and displacement restitution matrices shall be provided as files: ATM matrix - ATM_OP4.dat, DTM matrix - DTM_OP4.dat. The model shall be presented in Nastran model original units in MKS standard. SC FEM cover documentation shall include the following: Craig-Bampton model description, SC full-scale FEM description, modal damping and rigid body mass properties, restitution matrix description, test runs description. Units: force - Newtons, linear dimensions - meters, mass - kilograms, time - seconds.

Coupled loads calculation shall be done for cases where maximal values of internal force factors at SC interface occur: SC transportation as part of AU, ILV launch and for transitional events during flight. SC structure accelerations, loads and deformations for joint elastic loading are also defined.

Random vibration during SC and GSE transportation

The spacecraft is subjected to random vibrations during rail transportation at Baikonur. Random vibration levels during transportation as part of AU and ILV do not exceed those specified in the table below

Table. Random vibration during SC transportation

Frequency, Hz	Vibration acceleration spectral density, g ² /Hz		
	Lon.	Ver.	Lat.
2	0,000075	0,00015	0,00015
4	0,000575	0,0033	0,00033
8	0,002	0,0032	0,00066
10	0,0006	0,0032	0,0008
14	0,00028	0,002	0,00033
20	0,001	0,00015	0,001
25	0,000275	0,00015	0,00031
30	0,000275	0,00015	0,0003
35	0,0005	0,00015	0,000185
40	0,00018	0,00015	0,000037
45	0,000125	0,00015	0,000037
50	0,000125	0,00015	0,000037

Nominally, during a launch campaign there are five SC transit along the railroad. Transportation routes, distances, time en route are shown in table below.

Table. Transportation durations

Transportation route	Distance, km	Time en route, hr	Motion time, hr	Speed, km/hr
Airfield - PPF (inside SC shipping container)	58	8-12*	6	≤ 15
PPF - HPF (inside a container)	0,3	0,67	0,6	≤ 5
HPF - AUPF (inside a container)	0,3	0,67	0,6	≤ 5
AUPF - LV/ILV processing facility (as part of AU)	10	4	3,5	≤ 5
LV/ILV processing facility - launch pad (as part of ILV)	3	2	1,5	≤ 5
Note: * - depends on rail traffic				

Measuring and recording of vibration loads during all transportation events is done using dynamic loads measurement system. Measurement results are used for:

- Confirmation that no off-nominal impacts take place,
- ICD requirement verification,
- Load assessment in case of off-nominal situation.

Measuring and recording of vibration loads is done in the course of any transportation continuously. Measuring accelerometers are placed at spots agreed with Customers. Results are provided to the Customers once a transportation is complete.

SC random vibration during lift-off and in-flight

The random vibration environment during lift-off and in-flight at the spacecraft interface is enveloped in the following figure and table. The environment applies to components within 0,5 m from the separation plane along any direction. This environment is not attributable to the whole spacecraft as a rigid base excitation. During lift-off the vibration level at frequency of 200 Hz may reach 0,05 g²/Hz for 2 seconds.

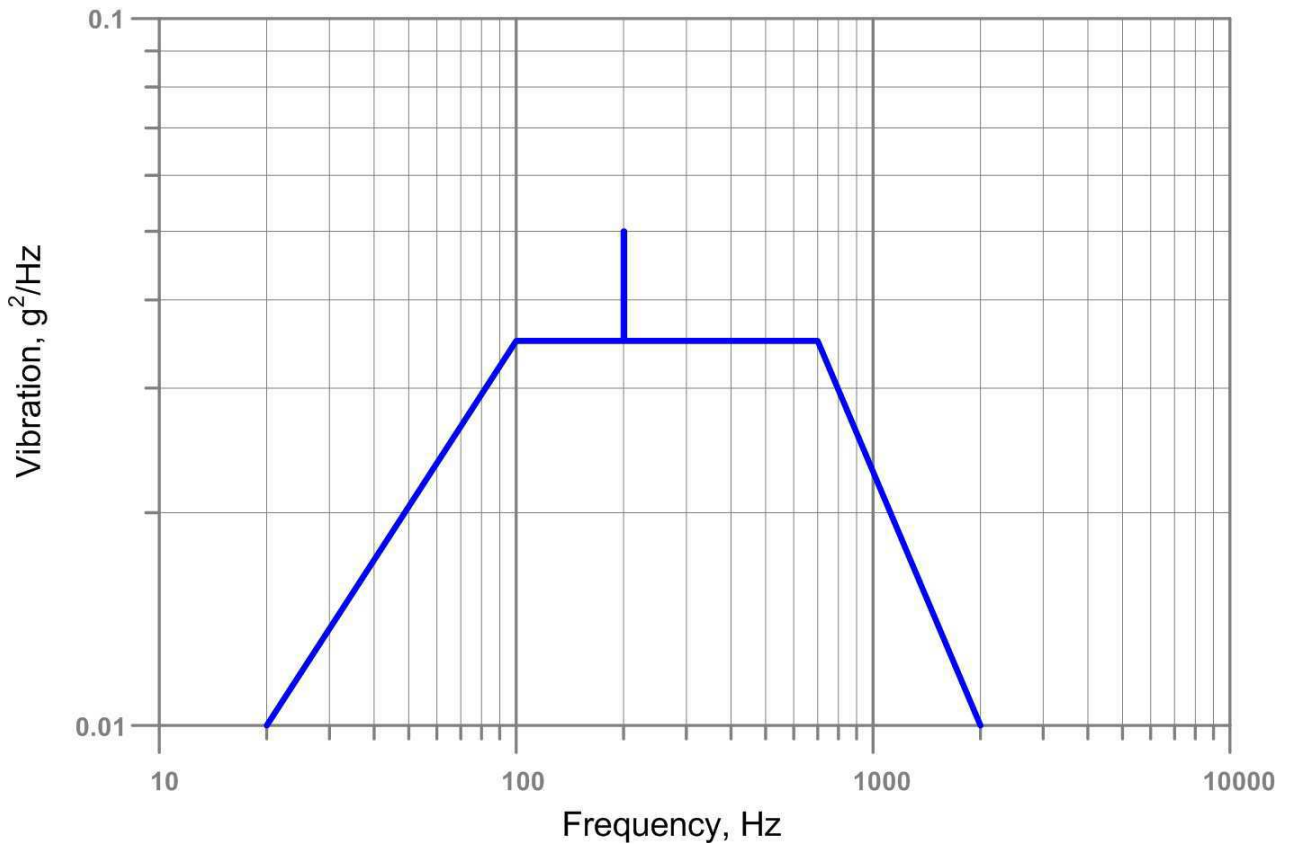

Figure. Random vibration during lift-off and in-flight

Table. Random vibration during flight

Frequency, Hz	Vibration acceleration spectral density, g ² /Hz
20	0,01
100	0,035
700	0,035
2000	0,01
Overall level	6,8 g _{rms}

Shock

Shock loads affecting spacecraft are generated by ILV systems operation. The maximum shock at the spacecraft interface occurs at the moment of spacecraft separation. Shock response spectra (Q = 10) at SC interface (longitudinal and lateral directions) for RUAG adapters is shown on figure below. Shock load values are attributable for a point located 50 mm below the separation plane. For a cluster launch using a dispenser the shock environment differ from the one shown below.

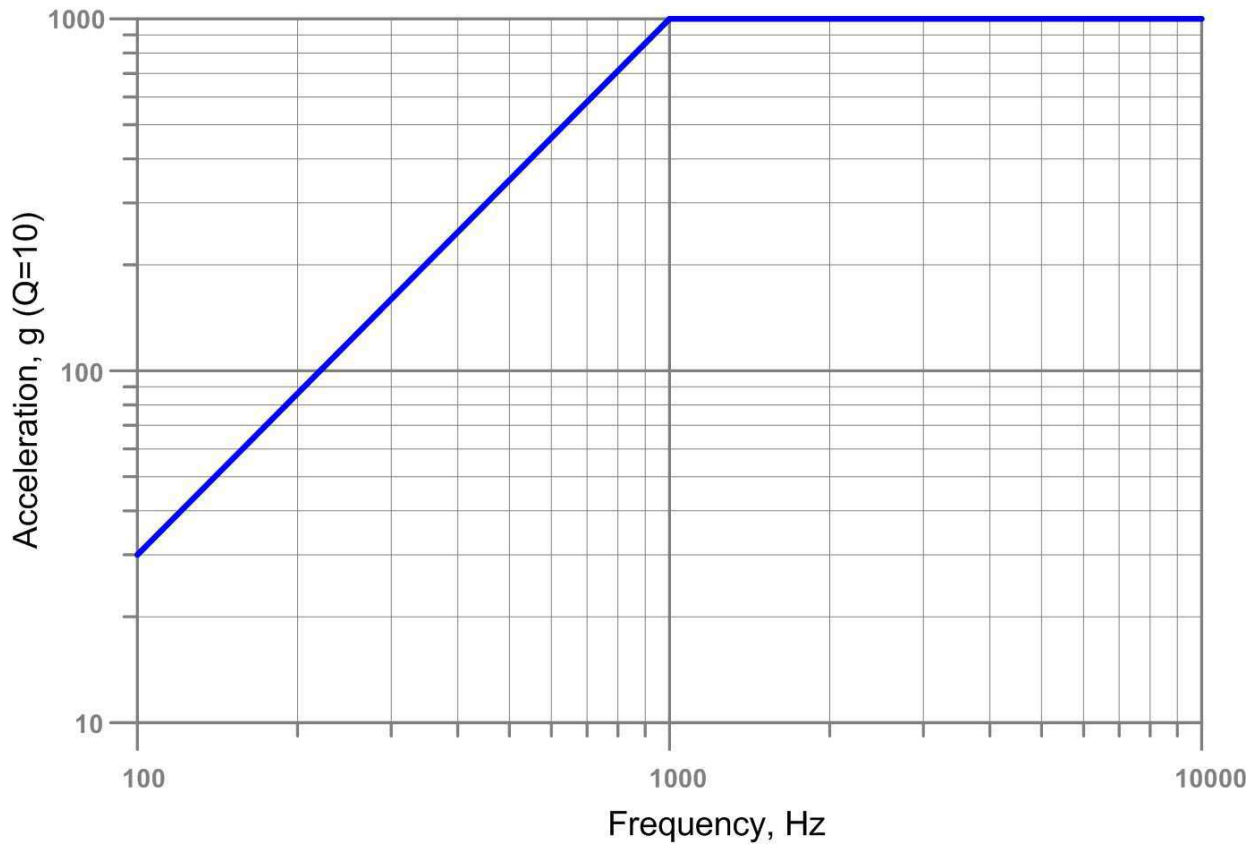

Figure. Maximal shock during lift-off and in-flight

Acoustics during lift-off and in-flight

Maximum acoustic pressure occurs during lift-off and transonic flight. Acoustic sound pressure level at 1/3 octave band center frequency inside fairings are given in table below.

Table. Acoustic parameters inside fairing

Frequency, Hz	Acoustic pressure level, dB	Frequency, Hz	Acoustic pressure level, dB
31,5	119	630	127
40	121	800	125
50	123,4	1000	122
63	127,5	1250	121
80	130	1600	120
100	129	2000	119
125	130	2500	118
160	131	3150	117
200	133	4000	115
250	134	5000	114
315	133	6300	113
400	131	8000	111
500	129		

Note:

- overall acoustic sound pressure level is 142 dB
- duration = 60 sec for three-stage configuration and 40 sec for two-stage configuration

Electromagnetic environment

The spacecraft will experience electromagnetic radiation stemming from:

- The background, or ambient, cosmodrome environment during ground processing,
- Ground emitters actively used during launch operations and during launch,
- ILV emitters.

Each of these sources is defined below in more details.

Operation of SC transmitters and other electronic equipment shall be coordinated with electromagnetic emissions from the vehicle and launch site assets.

The ambient Baikonur cosmodrome electromagnetic environment is not static but varies by location, and changes over time as new equipment is introduced and older equipment is retired. The following figure provides preliminary maximum values for electromagnetic fields levels expected at the launch site. These environments will be updated during the integration process.

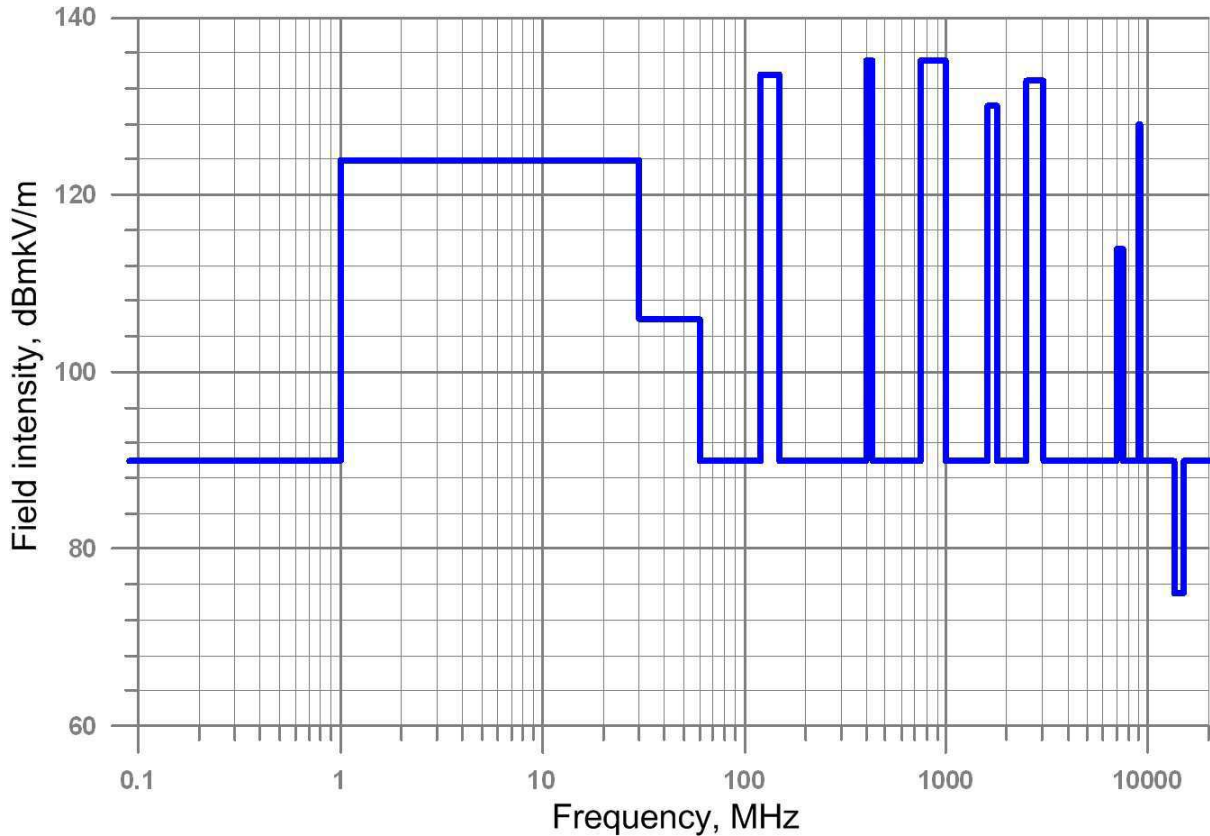

Figure. Launch site emission levels

The ILV electromagnetic parameters are given below.

Zenit-2SLB employ three sets of Sirius radio and telemetry system operating in 5 frequencies total. Sirius equipment is located on second stage instrumentation bay.

Zenit-3SLB, besides the above, employs the two-frequency BITS-B telemetry equipment set located on Block DM-SLB and sets of satellite navigation receiving equipment operating with Glonass and GPS.

Zenit-3SLBF employ two sets of Sirius radio and telemetry system operating in 4 frequencies total. Besides that, Fregat-SB is equipped with two telemetry system transmitting units, trajectory measurement system impulse receiver/responder, sets of satellite navigation receiving equipment operating with Glonass and GPS.

The maximal EM field intensity levels at upper stage/spacecraft interface created by ILV systems are shown in the table and on figure below. At that, factors like antenna type and orientation, their location relatively to spacecraft are considered. However, attenuation effected by fairing prior to its jettison is not taken into account. ILV fairing will attenuate field intensity affecting spacecraft during prelaunch processing and after launch prior to fairing jettison. The emission attenuation degree will be analyzed in details for each mission during PIMA.

Table. Maximal field intensity levels at upper stage/spacecraft interface created by ILV systems

Equipment	Frequency range, MHz	Field intensity, dBmV/m		
		Zenit-2SLB	Zenit-3SLB	Zenit-3SLBF
Sirius	230,0 - 232,6	150,9	128,0	
Sirius	238,0 - 240,6	150,9	128,0	134,76
Sirius	246,0 - 248,6	150,9	128,0	134,76
TMS-M6	632,5 - 633,5			123,36
TMS-M1	642,5 - 643,5			123,36
Sirius	1009,2 - 1011,8	149,6	124,1	140,79
Sirius	1016,7 - 1019,3	149,6	124,1	140,79
BITS-B	1025,25 - 1027,75		145	
BITS-B	1033,25 - 1035,5		145	
Glonass, GPS	1575,0 - 1620,0		19	19
38G6	2723,6 - 2726,3			45
38G6	2797,5 - 2807,5			142,13
Others		110,9	70	84

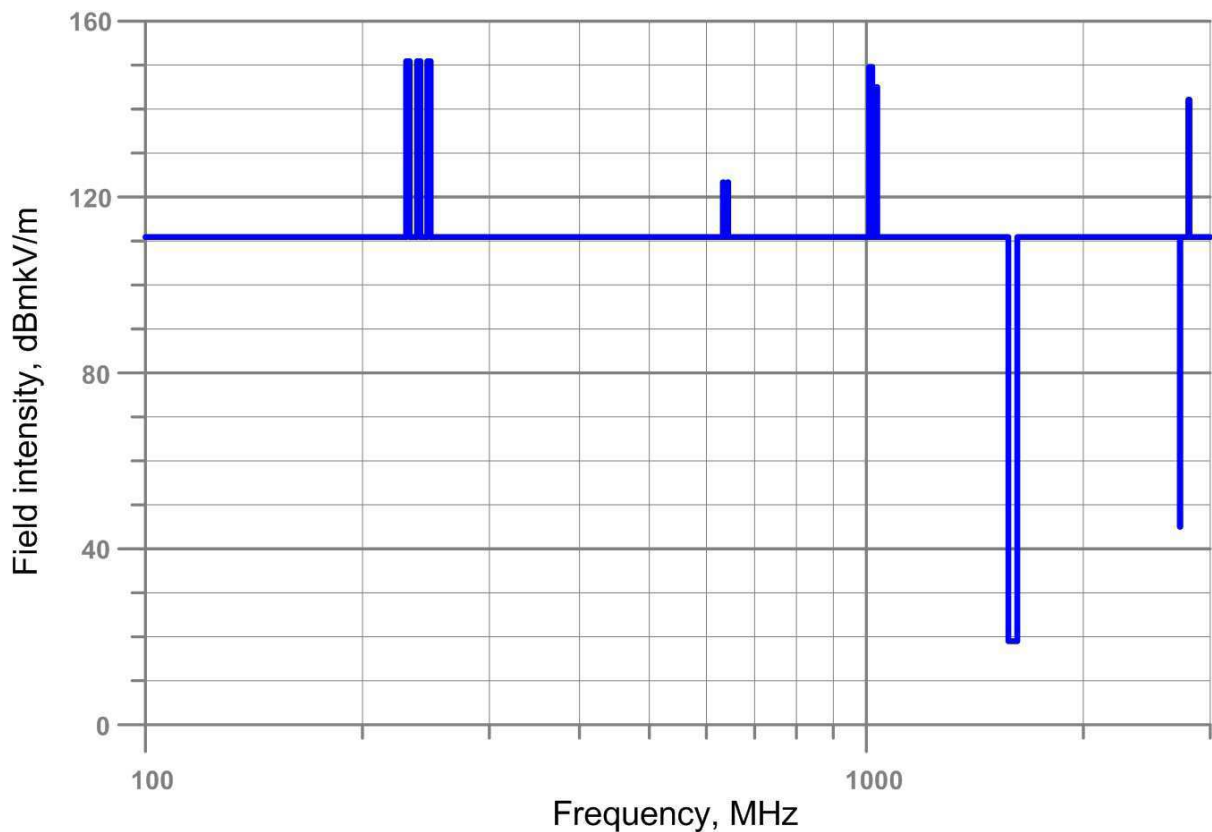

Figure. ILV imposed field intensity maximum levels envelope

Thermal and humidity environments

This section describes thermal and humidity conditions to which the spacecraft will be exposed from arrival to the launch site airport through separation in orbit.

Ground thermal and humidity environment

Starting from SC shipping container off-loading from an aircraft and its loading onto a rail car as well as throughout launch processing until ILV launch the required SC environment thermal and humidity parameters are continuously maintained using stationary temperature control systems, mobile temperature control systems, and launch complex temperature control systems including low pressure temperature control system (LPTS) and high pressure temperature control system (HPTS). Temperature and humidity environment values for each step of ground operations are presented in the table below

Table. Temperature and humidity parameters during ground operations

Step	Temperature, °C	Relative humidity	Operating system, nominal flow
Airfield - PPF (transit inside shipping container)	15 - 30	≤ 60%	Mobile system 3000-6000 m ³ /hr
PPF	17 - 23	40% - 60%	Stationary unit
PPF - HPF - AUPF (transit inside a container)	15 - 30	≤ 60%	Thermal-insulated container
HPF	15 - 25	30% - 60%	Stationary unit
AUPF	15 - 28	35% - 60%	Stationary unit
AUPF - LV/ILV processing facility (transit as part of AU)	15 - 30	≤ 60%	Mobile system 3000-6000 m ³ /hr
LV/ILV processing facility	10 - 25	≤ 60%	Mobile system 2000-2200 m ³ /hr
LV/ILV processing facility clean room	21 - 26,7	30% - 60%	Stationary unit
LV/ILV processing facility - LC (transit as part of ILV)	10 - 25	≤ 60%	Mobile system 2000-2200 m ³ /hr
ILV at the LC prior to LOX loading	10 - 25 (10 - 35)	DP ≤ -10 °C	LPTS 5000 (9500) m ³ /hr
ILV at the LC starting from LOX loading until L-12 minutes	10 - 25 (10 - 35)	DP ≤ -10 °C (DP ≤ -30 °C)	LPTS 5000 (9500) m ³ /hr
ILV at the LC starting from L-12 minutes until launch	10 - 25 (10 - 32)	DP ≤ -55 °C	HPTS 2250 - 2700 kg/hr

Notes:

- values in brackets are for Zenit-2SLB
- air temperature is maintained with tolerance of ±2 °C from a value prescribed by Customers within a given range
- relative humidity does not exceed limit values shown in the table
- DP - Dew Point
- LOX - Liquid OXYgen

At the PPF, HPF, AUPF, LV/ILV processing facility temperature and humidity are supported by the facility temperature control system with parameters control included. Monitoring is performed for temperature-humidity environment control in rooms. Reports are submitted to the Customer regularly (nominally 1-2 times a day), and beside this the Customer can get temperature-humidity environment parameters immediately for a current moment.

Whenever SC is in transit from the launch site airport and between processing facilities LSP- or Customer-provided temperature control units are used.

At the LV/ILV processing facility during move of the fully-assembled ILV onto transporter/erector the temperature control is interrupted for no more than 60 minutes.

After ILV roll-out to the LC the air supply from mobile temperature control unit switches to LPTS that provides temperature controlled air into the fairing until transporter/erector demating and evacuation at L-12 minutes. Temperature control from L-12 minutes until launch or after L-0 in case of launch abort until transporter/erector recoupling to the ILV is supported by HPTS laid inside the ILV.

During SC transit from PPF to HPF and back inside LSP container the SC thermal and humidity environment is supported by container thermal insulation properties and minor transit time. During SC transit from PPF to HPF and back the conditioned air flow inside LSP container or Customer container may be provided using mobile conditioning unit, if required. At that, the LSP monitors temperature and humidity of the air supplied.

Once the SC encapsulation is complete the temperature and humidity monitoring is done at the fairing air inlet during transits as part of AU or ILV and throughout the launch processing at the LC. Monitored values are provided to Customers.

The relative humidity of air supplied inside fairing is supported by dew point temperature that is set up during system adjustment.

SC pre-launch air impingement under fairing is calculated during the mission analysis and usually does not exceed 3 m/sec. Temperature control systems that supply air inside the fairing are adjusted as per the made analyses.

The following figure provides principal diagrams of air flow for an encapsulated SC. The figure shows the ILV integrated ascent unit. In this diagram the air egress to atmosphere is performed through the AU and second stage vent holes. Diagram for Zenit-3SLB is not shown since it is similar to Zenit-3SLBF diagram with the only difference that air egress is done not via the transfer

compartment but via Block DM-SLB lower adapter. During the AU autonomous transportation all the outgoing air is directed back into the thermostating unit (closed circuit).

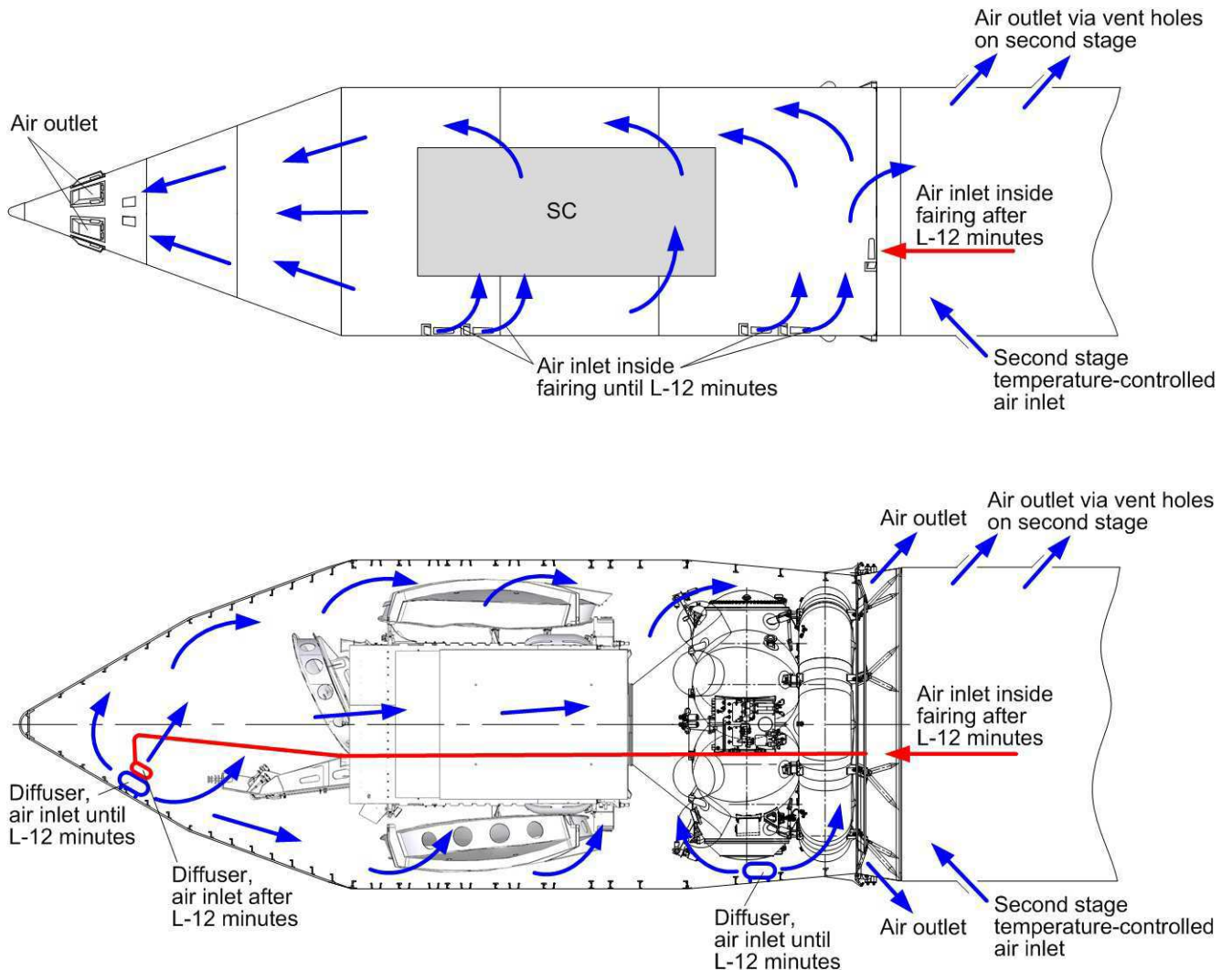

Figure. AU air flow diagrams for Zenit-2SLB and Zenit-3SLBF

Thermal environments in-flight

SC thermal environments during flight are driven by multiple factors. Starting from launch and until fairing jettisoned the SC thermal environment is driven by its own thermal emissions from ILV and SC onboard equipment operation as well as thermal flux from fairing interior surfaces (no more than 500 W/m²), that is reduced due to using fairing thermal insulation and heat-removing facings.

After fairing jettisoned, SC thermal environments are defined by its own emissions from ILV and SC onboard equipment operation, free molecular heating (no more than 500 W/m²) which is reduced due to late fairing jettison as well as sun radiation and SRBs jets thermal impact on SC surface (no more than 9 kW·sec/m²) and upper stage attitude engines (for three-stage configuration only, no more than 5,1 kW·sec/m²).

SC thermal environment analysis for pre-launch operations and in-flight is performed for each mission in the course of mission analysis.

SC thermal model

The preferable thermal model format is the Thermal Desktop format, version 5.3 or higher. Also, a possible option is Thermica, version 3.2 only. A model consists of a file that includes geometrical description of nodes and parameters of conductive connections among them as well as a file that includes data set describing optical and thermophysical properties of these nodes.

A model shall be divided by Customers into such number of nodes that is required by Customers to assess the SC thermal environment but no more than 800 nodes are preferred.

Also, a model shall include, or have a separate file with the following features:

- Various scenarios of SC onboard equipment thermal emissions during ground operations and in flight,
- Heaters (output and conditions for their enabling/disabling).

A thermal model shall be accompanied with a design note that includes:

- Model brief description,
- Table of allowable temperature ranges,
- Table of onboard equipment thermal emission scenarios,
- Table of thermal load timelines (which thermal emission scenario is applicable for each phase),
- Description of nodes (fragments) including optical and thermophysical properties, active sides, properties of thermal insulation covering a node (if any).

Also, a thermal model shall account for node property changes under conditions of ground processing, for instance, change of thermal resistance of screen vacuum thermal insulation.

Pressure venting

Venting during injection is performed via venting holes on fairing, upper stage and second stage (see figure below, Zenit-3SLB diagram is not shown since it is similar to Zent-3SLBF diagram). Parameters of venting holes are defined in the course of venting analysis for during mission integration.

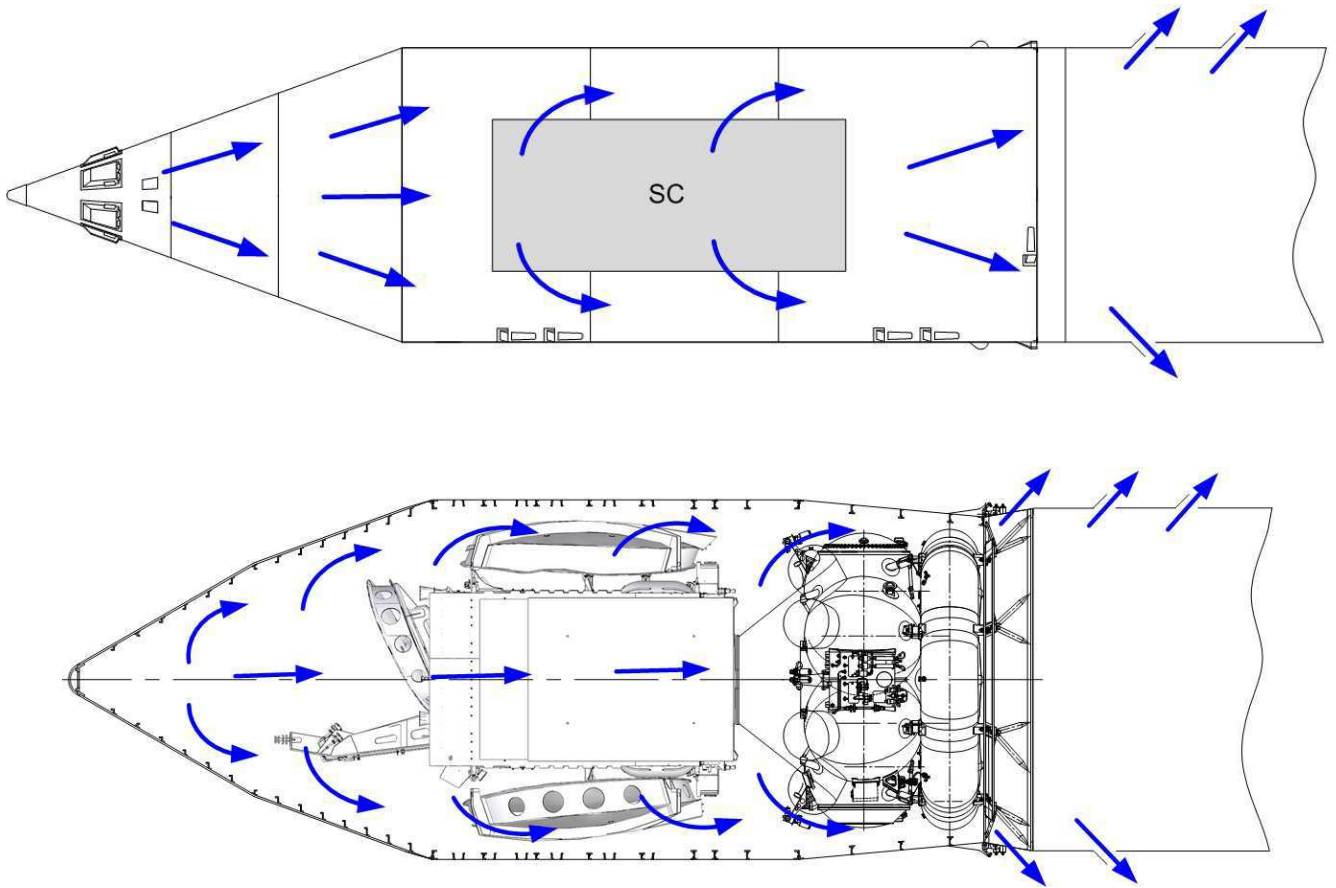

Figure. AU venting for Zenit-2SLB and Zenit-3SLBF

The pressure decay rate inside fairing prior to fairing jettison command does not exceed $0,0255 \text{ kgf-sec/sm}^2$. The typical pressure decay graph during spacecraft injection is shown on figure below. The pressure decay rate analysis is done for each mission as part of PIMA.

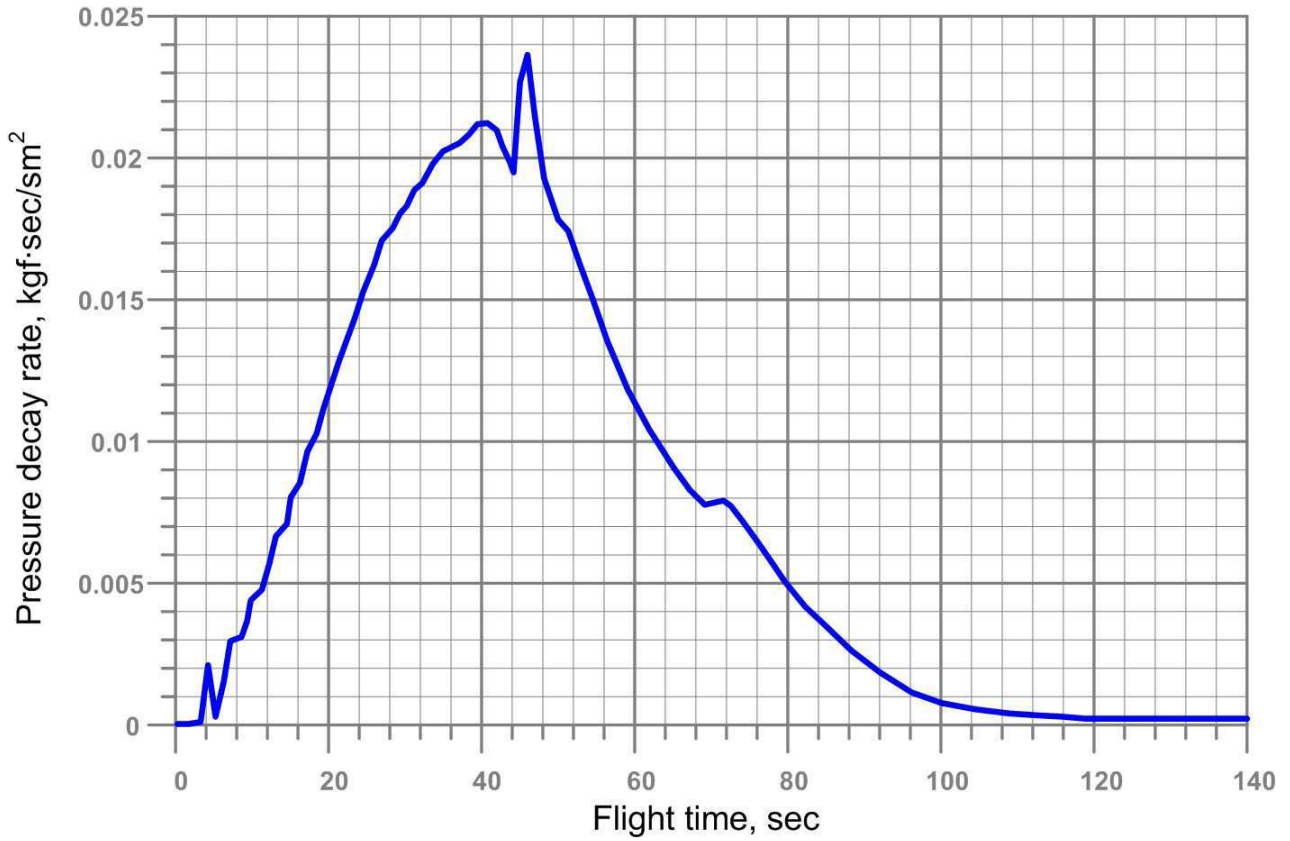

Figure. Typical pressure decay graph as function of flight time

Excessive pressure inside fairing is within $-0,04 - 0,08 \text{ kgf/sm}^2$. Pressure drop inside and outside fairing when jettisoned does not exceed $0,002 \text{ kgf/sm}^2$. Typical excessive pressure graph as function of ILV flight time is shown on figure below.

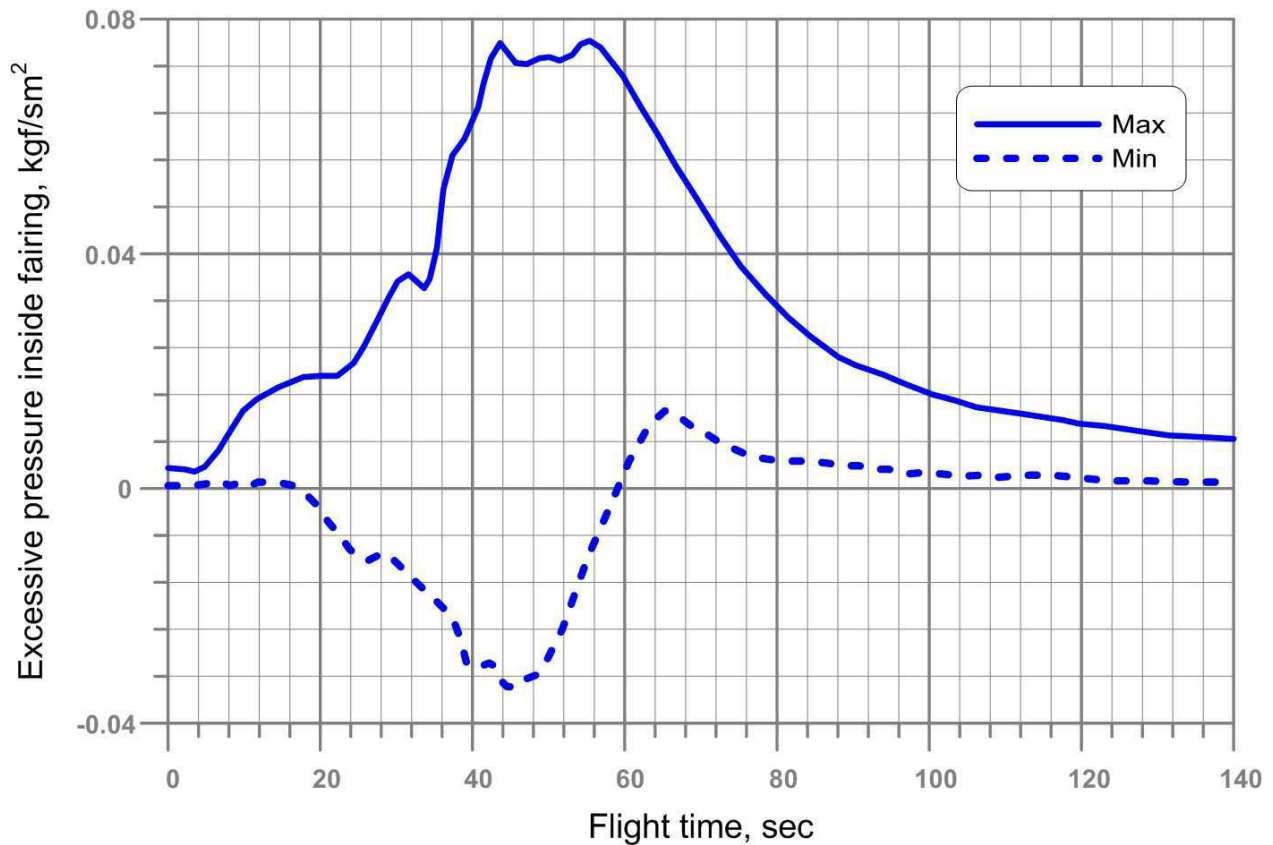

Figure. Excessive pressure inside fairing

Contamination

The Land Launch ground equipment, facilities and flight hardware that are in contact with SC environment are designed and prepared for SC protection from contamination.

ILV propulsion systems are screened to avoid direct impact of jets on SC surface. Indirect impact is minimized to reduce negative impact on SC. Fairing pyros and SC separation system pyros are designed to protect SC from contamination.

Instructions on cleanliness requirements and contamination control methods shall be formalized during PIMA and will be included into the Contamination Control Plan.

During ground operation SC is protected due to its being in a clean environment.

During SC transportation from the airport the air supply 5000 class as per FED-STD-209E into SC shipping container may be anticipated as basic or back-up option. SC operations at Baikonur launch site (SC off-loading from shipping container, stand-alone tests, fuelling, encapsulation) are performed inside facilities with controlled environment, 100000 class as per

FED-STD-209E. The table below provides comparison of ISO 14644-1 standard vs. FED-STD-209E.

Table. ISO 14644-1 vs. FED-STD-209E

ISO 14644-1 class	FED-STD-209E equivalent	Maximal particle number in m ³		
		≥ 0,5 mkm	≥ 1 mkm	≥ 5 mkm
ISO 6	Class 1000	35200	8320	293
-	Class 5000	176000	41600	1465
ISO 7	Class 10000	352000	83200	2930
-	Class 25000	883000	208000	7320
ISO 8	Class 100000	3520000	832000	29300
ISO 9	Room air	35200000	8320000	293000

Cleanliness of flight hardware that is in direct contact with SC environment is assured during manufacturing phase and is maintained during storage, transportation and processing at the launch site.

At that, additional cleaning of flight hardware surfaces is done at the launch site.

Cleanliness level (mechanical dust) of inner surfaces of AU components that can be supported prior to AU assembly is shown in table below.

Table. AU inner surface cleanliness level

Dimension	Maximal particle concentration on fairing interior surfaces
> 100 mkm	30129 particles/m ²
> 250 mkm	753 particles/m ²
> 500 mkm	32 particles/m ²

Potential sources of the SC contamination in flight are: pyros, ILV sections during venting system operation, plume impingement from the second stage SRBs, upper stage steering engines and outgassing. All of these sources are addressed during PIMA.

Pyros used for fairing jettison and SC separation are leak-proof and are not sources of discrete contamination and outgassing.

The venting system design excludes gases migration from second stage (for two-stage configuration) or upper stage (for three-stage configuration) towards a spacecraft.

The plume effect on the SC from second stage SRBs is negligibly small because of their location on the aft end of the stage.

After SC separation, upper stage perform a contamination and collision avoidance maneuver (CCAM) to ensure a negligibly small contaminating effect on spacecraft from the upper stage steering engines and stage venting. CCAM features include stage attitude control for optimal orientation relative to the SC.

6. LAND LAUNCH FACILITIES

Overview Land Launch has the advantage of using proven and established facilities at Baykonur Cosmodrome. These include:

- Krayny Airport for launch personnel arrival and departure;
- Yubileyny Airport for spacecraft and ground support equipment shipment;
- Upper stage processing facility located at site 254;
- Payload processing facility and ascent unit processing facility at site 31;
- Zenit technical complex located at site 42 for Zenit processing and mating of the Ascent Unit with the Zenit stages followed by check-out of the integrated launch vehicle (ILV);
- Zenit launch complex located at site 45 for launching integrated launch vehicles.

A map of the Land Launch Baykonur facilities is shown in figure 6-1.

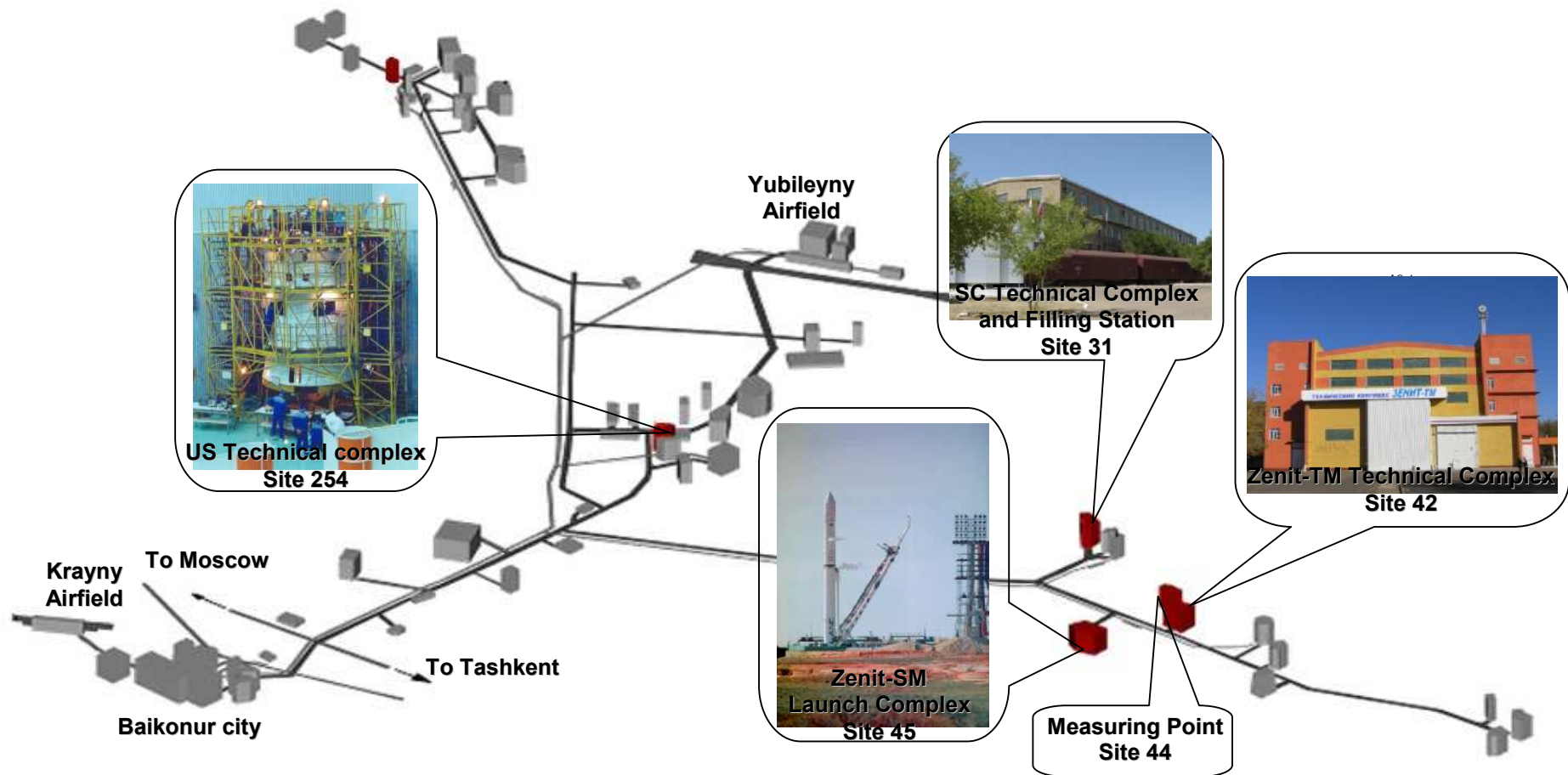

Figure 6-1. Allocation of main facilities (sites) at Baykonur Cosmodrome

6.1 Transportation of personnel and cargo to and from Baykonur

Krayny Airport

Personnel fly between Moscow and Baykonur via Krayny Airport which is situated six kilometers west of Baykonur city. It can accommodate midsize aircraft for passenger travel throughout the year. TsENKI, via Roscosmos (Russian Federal Space Agency) will assist customer personnel in obtaining visas and will provide customer personnel with access to the Cosmodrome as well as badges to the required facilities (Figure 6-2).



Figure 6-2. Krayny airfield in Baykonur

Yubileiny Airport

Yubileiny Airport is located 45 km north of Baykonur city within Baykonur Cosmodrome and is operated by Roscosmos. Its 4,500 meters long and 84 meters wide runway conforms to ICAO standards for Class 1 airports, was built to accommodate the landings of the Buran space shuttle. It handles aircraft of all classes for both freight and charter flights, including Boeing 747s and Antonov 124s. Commercial launch customers have used it many times for delivering spacecraft and associated support equipment. The airfield can operate year-round. A typical off-load is shown in Figure 6-3.

Upon arrival, the SC container and associated equipment are offloaded from the aircraft and transferred to railcars that are located approximately 50 to 80 meters from the aircraft. Cranes, forklifts and other auxiliary equipment are available for these operations. The airport is connected with all major cosmodrome facilities by railroads and motorways.



Figure 6-3. Spacecraft Off-Loading at Yubileyny Airfield

**Transportation at
the cosmodrome**

All Baykonur sites and facilities are connected by motorways and railroads among each other. Land Launch provides the customer with all necessary transportation of equipment and people on base. Generally, equipment will move between facilities by rail while people will move by road. At the launch site the spacecraft is moved from Baykonur airport to PPF/AUPF (site 31), from AUPF to LV/ILV technical complex (site 42), and from site 42 to the launch pad at site 45. During satellite moves all dynamic loads are measured using dynamic loads measurement system provided by LSP. Spacecraft is transferred via railroad (Figures 6-4 and 6.5) protected (inside SC shipping container during first move) and encapsulated (second and third move) with continuous supply of clean, conditioned air inside as described in Section 4.



Figure 6-4. Transfer of Zenit-3SLB Ascent Unit with thermostating wagon



Figure 6-5. Transfer of Zenit-3SLBF Ascent Unit with thermostating wagon

6.2 Processing facility for spacecraft, Fregat-SB, adapter and Ascent Unit – site 31

Overview The processing facilities for spacecraft, upper stage and ascent unit comprise the complex of buildings and facilities at site 31 that has been previously used for processing of multiple satellites. Here, all spacecraft, upper stage and ascent unit preparation processes take place. SC loading is done at the hazardous processing facility (HPF). Access to PPF, USPF and AUPF is controlled so to be in compliance with Customers' security requirements. The layout of main facilities at site 31 is shown on Figure 6-6.

Major PPF, USPF and AUPF features include:

- Spacecraft processing areas;
- SC GSE control areas;
- Garment rooms with air lock for personnel;
- US processing areas;
- AU processing areas;
- SC personnel office area.

HPF features include:

- SC and upper stage loading facility

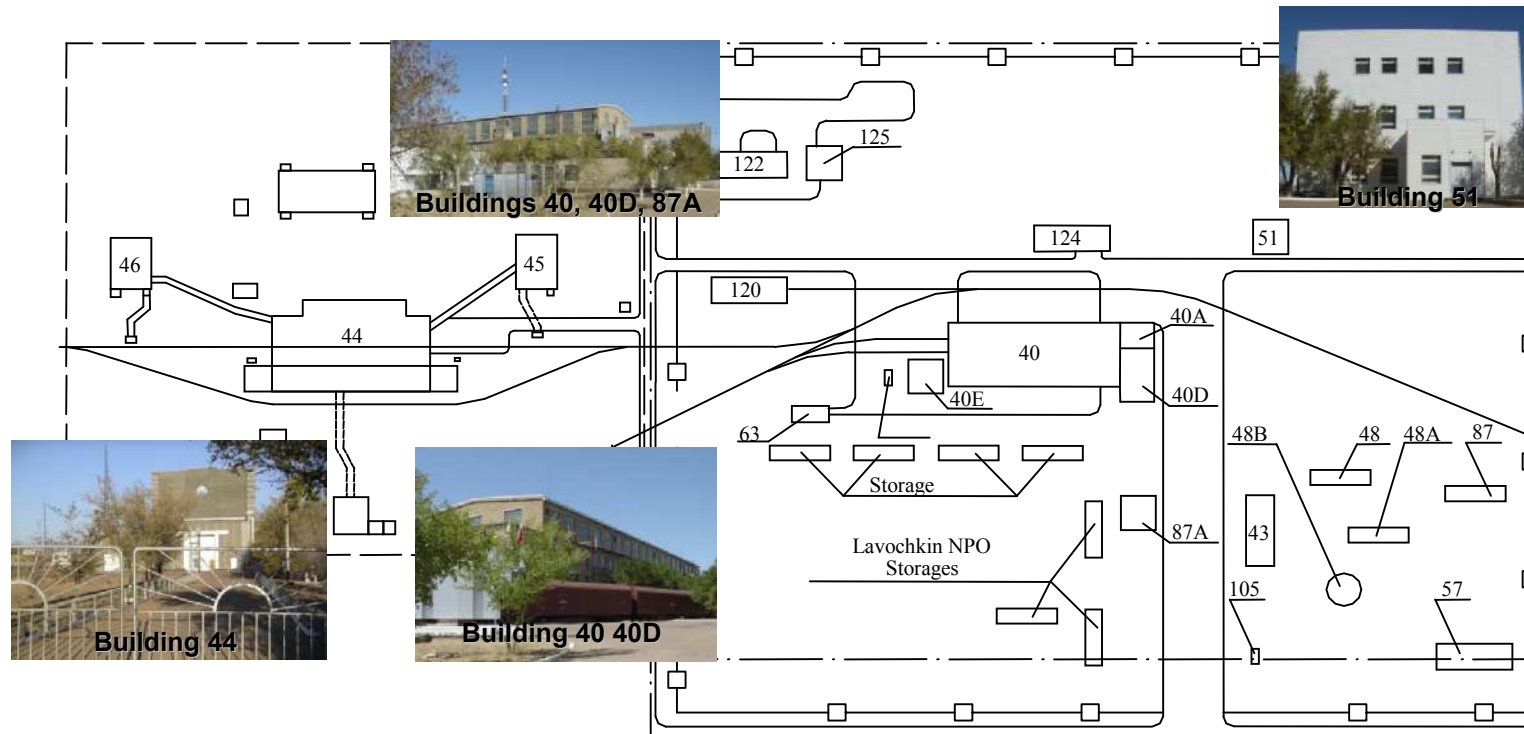

The technical complex of Site 31 is intended for spacecraft processing and AU assembly. The non-hazardous operations of SC preparation and AU assembly are performed in Buildings 40 and 40D. Hazardous operations are performed in facility 44.

Figure 6-6 – Site 31 layout

40	Assembly and test building (ATB)	51	Support building
40A	Annex to ATB	57	Boiler Facility
40Д	Annex to ATB (clean room – PPF)	63	Receiver Facility
40E	Ventilation facility	87A	Uninterruptable Power Supply Facility
43	Charge-Storage Battery Station	105	Transformation Station (6/0.4 kV)
		120	IAE Storage
		122	Refrigerating Center
		124	Laboratory Building
48	Cooling Tower	125	Cooling Tower
48A	Water Recycling Pump Station	380	Electro-Diesel Station (mobile, 200 kW)
48Б	Water Tank	87	Workshops

**Building 40/40D,
PPF and AUPF**

This processing facility at Site 31 includes building 40 and building 40D. The processing facility layout is shown on Figure 6-7. Building 40 is a spacious high-bay facility. Customer equipment operations are performed in three major areas: Area A, Area B, and Area C. Area A is intended for combined operations, i.e. Ascent Unit assembly (see section 8.5). Area B is used as pathway for moving items and cargo between Area C and Area A and to/from room 119, room 119A, and room 119B of building 40D. This is the area where satellites are moved out from their transport containers. Area C is used for SC and GSE containers off-loading, their cleaning prior to moving to Area B. Rooms 119, 119A and 119B in Building 40D are the usual locations for SC processing and check out prior to fuelling.

Once processed at site 254, Block DM is transported to fuelling facility and once loading operations are complete to Building 40 afterwards. At Building 40 it is moved from Area C to Area A for Ascent Unit assembly combined operations.

Once processed in Area C, Fregat-SB is transported to fuelling facility and moved back to Area C and to Area A afterwards for combined operations.

Once a satellite is loaded at the fuelling station, it comes back to Area B and is moved to Area A for Ascent Unit assembly combined operations.

**Building 40D
Office areas**

Building 40D is a three-storey building adjacent to Building 40. It accommodates SC processing area and GSE allocation rooms as well as personnel and administrative offices. Layouts of second and third floors of Building 40D are shown on Figures 6-9 and 6-10, respectively.

Building 40D accommodates office space and conference rooms for Customer personnel who support SC processing operations including separate rooms for SC manufacturer personnel and Customer personnel. Phone lines and data links are available.

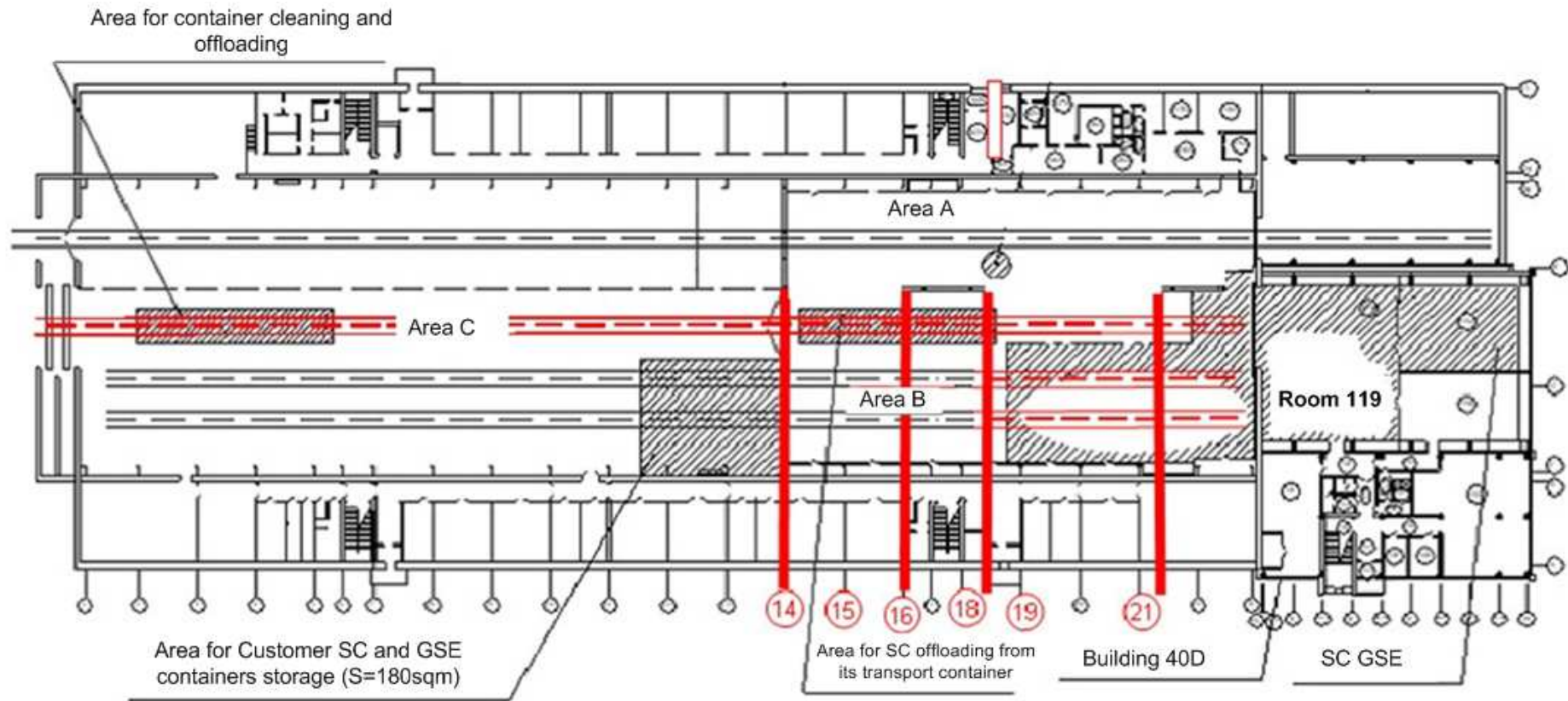

Figure 6-7 – Processing facility layout (Buildings 40 and 40D)

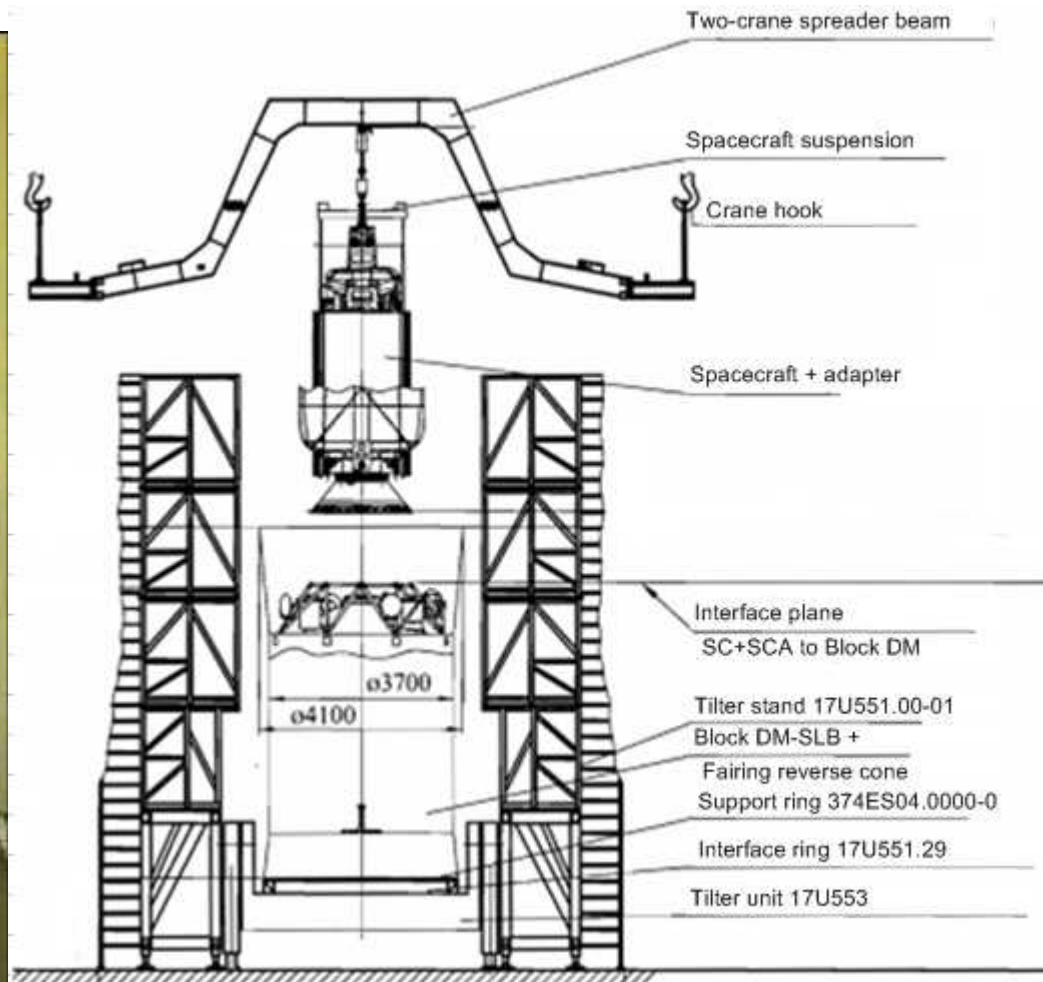

Figure 6-8 – AU assembly in Area A

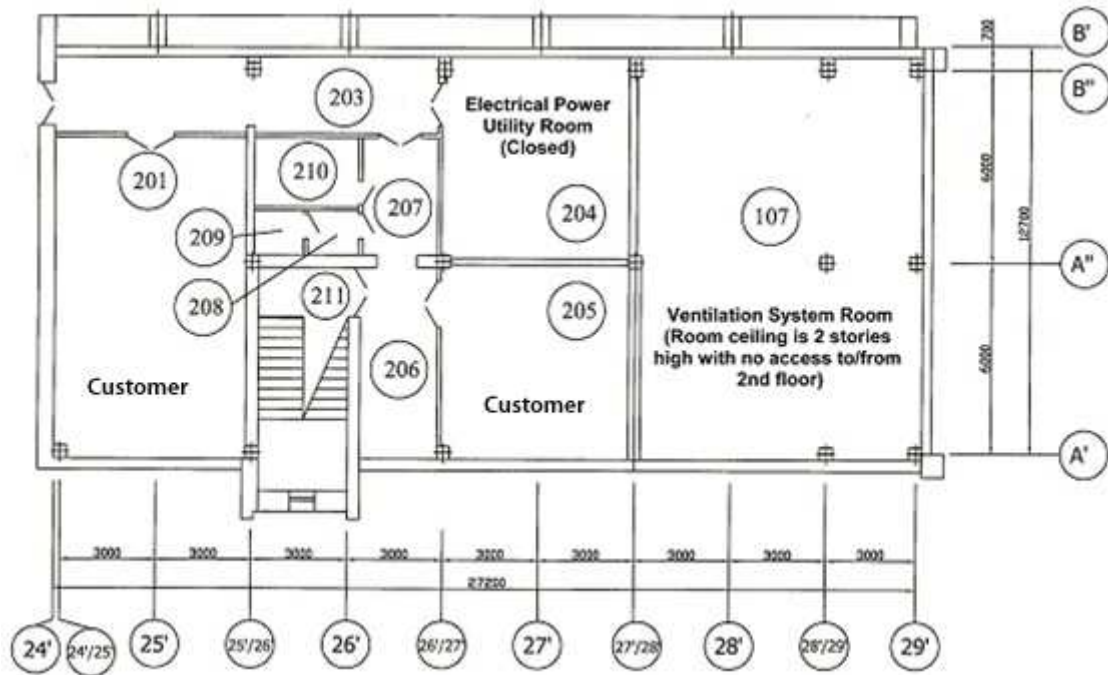

Figure 6-9 – Building 40D second floor layout.

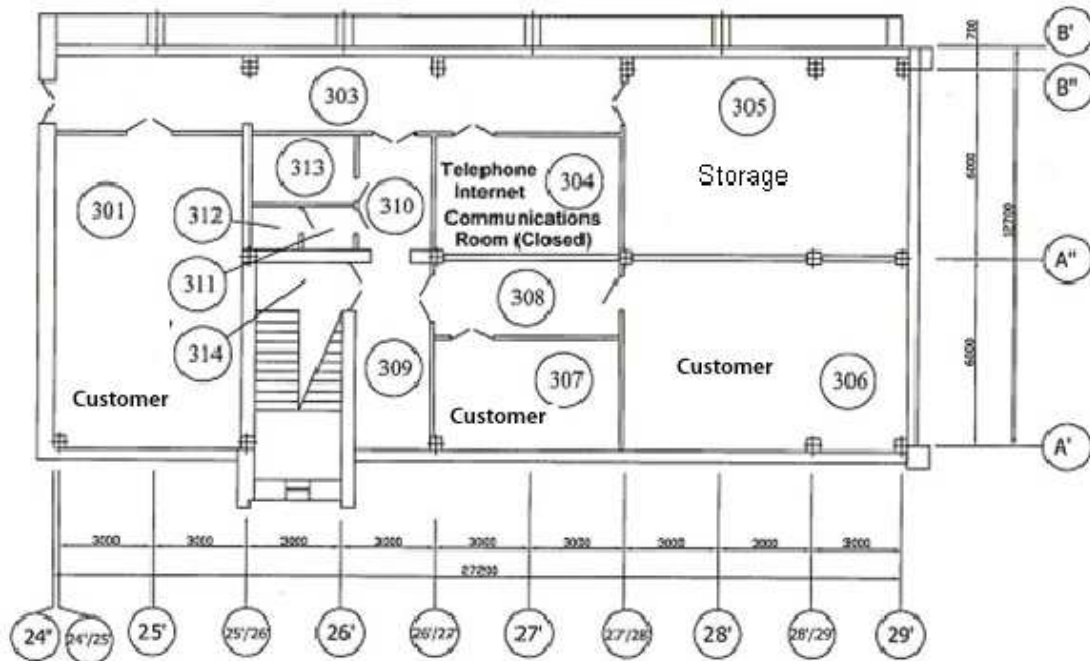
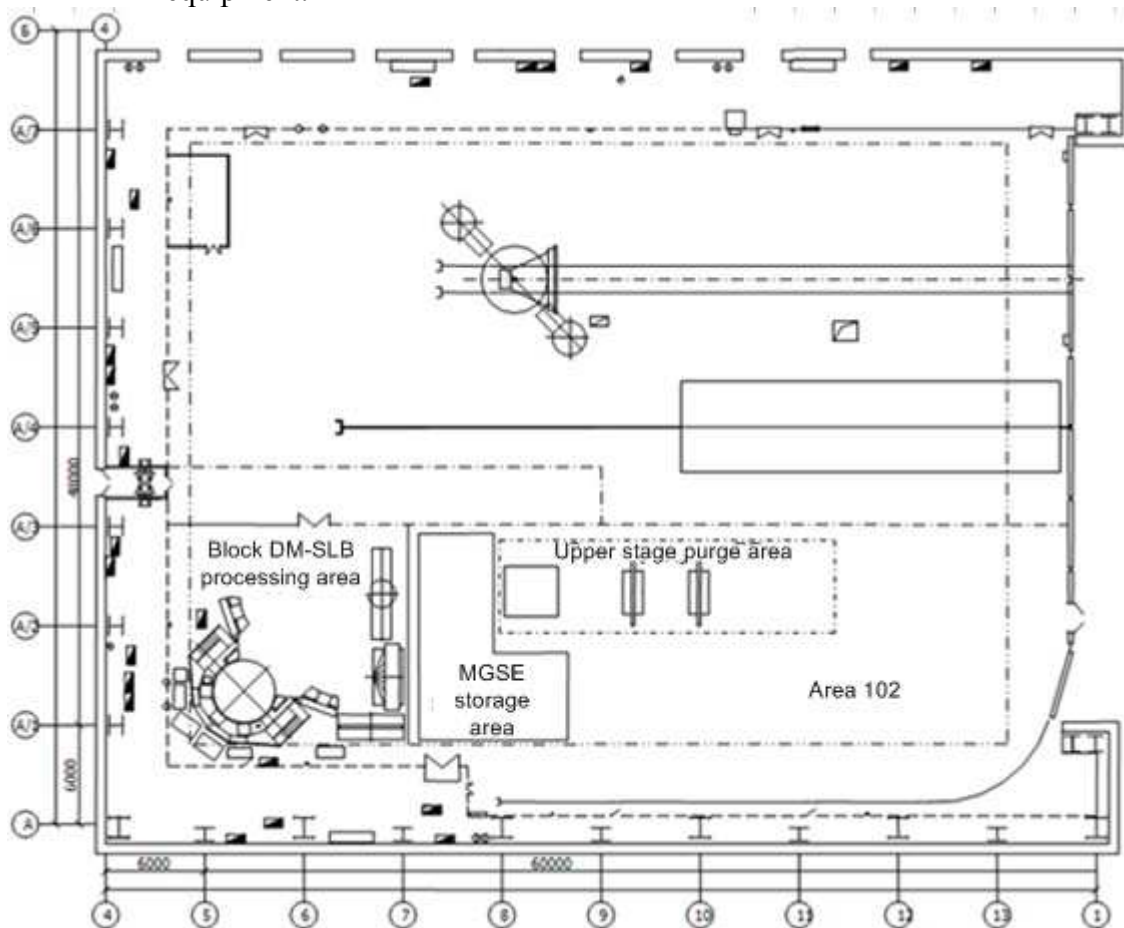

Figure 6-10 – Building 40D third floor layout.

6.3 Site 254 Payload Processing Facility

Overview

Block DM processing facility at site 254 is built in 1996 and currently is used for processing 11S861 upper stage, 11S861-01 upper stage, DM upper stage. Total of 46 upper stages of various purpose and various modifications have been processed in this facility. Block DM-SLB utilizes the technical assets including existing ground support support equipment.



Block DM processing area in hall 102 at site 254



6.4 Fuelling facilities

Overview

There are two fuelling facilities capable of supporting the SC loading operations.

Fuelling station 11G12 is located at site 31 300 m away from Building 40.

Fuelling station 11G141 is located at site 91 80 km away from Building 40.

Fuelling station 11G12



Fuelling station 11G12 complex

The main fuelling complex facility, Building 44, is a three-storey building accommodating a number of technological and office rooms (first and second floors). Second floor accommodates control room for work manager and fuelling equipment operators.

Building 44 is divided into three main operation areas:

- Hall 1 – fuelling hall for SC and US loading with fuel, $W \times L \times H = 22 \times 16 \times 15,5$ m;
- Hall 2 – compressed gases loading hall – $18 \times 16 \times 15,5$ m;
- Hall 3 – fuelling hall for SC and US loading with oxidizer – $22 \times 16 \times 15,5$ m.
- Two annexes (cleaning room and auxiliary hall) are located right next to Building 44. All working areas are divided by leak-proof sliding/swinging doors, 7×10 m. Same doors are at the facility ingress/exit, 7×10 m.

Rail tracks are available inside fuelling facility for cargo movement.

Electrical explosion-proof bridge cranes are available in Halls 1, 2 and 3 for handling operations, mirco-speed is available.

In the fuelling facility, the Customer will be provided with:

- Clean halls 1, 2, 3 for SC and GSE allocation for fuelling operations with cleanness class no worse than 100 000 as per Fed-Std-209E;
- Temperature inside halls 1, 2, 3 within $18 - 25^{\circ}\text{C}$;
- Relative humidity – 30...60%;

- Compressed gases:
 - § Gaseous nitrogen;
 - § Breathing air for SCAPE suits;
 - § A- and B-grade gaseous helium;
- Uninterrupted power supply;
- CCTV;
- EGSE grounding;
- Propellant vapor and waste collection and neutralization system;
- Water preparation system and FGSE decontamination system;
- Propellant vapor monitoring system and oxygen monitoring system: in case maximum permissible concentrations are exceeded a sound and red light go on.
 - The system monitors and issues OFF-NORM signal for MPCx1 to MPCx10:
 - N₂H₄, concentration measurement from 0,00005 mg/l, OFF-NORM signal at 0,0001;
 - N₂O₄, concentration measurement from 0,001 mg/l, OFF-NORM signal at 0,002.
 - Oxygen contents in ambient air from 15 to 25%.
- Phone lines (among launch site facilities, intercity, international) and facsimile;
- SC propellant temporary storage available;
- Venting;
- Emergency venting including absorber filters in case of gas contamination;
- Fire alarm systems (in technological and office areas);
- Fire fighting system;
- Emergency evacuation routes available (no emergency showers);
- Changing rooms;
- Office areas;
- Work area for work managers and controllers in the control room.

Hall 1 is equipped for operations with both fuels and oxidizers. Fuel and oxidizer equipment is located on the right and on the left from rail tracks, respectively.

Vacuum equipment may be provided for FGSE decontamination. This equipment provides 0,5 mm Hg vacuum.

Compressed gases are supplied with pressure from 0 to 390 kgf/cm².

Vapors are confined into vapor neutralization system via leakproof lines.

Wastes are collected into propellant waste collection and neutralization system.

Vapor and waste neutralization is environmentally friendly and does not produce any toxic substances except exhaust from diesel-powered incinerators.

Breathing air supply system is used for SCAPE suits. This equipment is compliant with EN12021 and OSHA 1910.134 (1998) standards.

Distilled water (see parameters in table 3.4.3.5-3 below) for equipment flushing and hot nitrogen (30⁰C – 40⁰C) for drying will be provided.

Parameter	Value
PH	6
Chlorides	0,1 mg/l
Iron	< 0,05 mg/l
Sulphates	< 0,5 mg/l
Nitrates	< 0,1 mg/l
Evaporation residue	4,5 mg/l

Fueling equipment decontamination system supports water preparation to required parameters. Water quality will be supported with analysis and quality certificate.

Hot nitrogen supply is supported by nitrogen flow from receiver room to Hall 1 followed by heating up to 30-40⁰C.

11G12 fuelling station is scheduled for major overhaul in 2012 through 2015.

Interface adapters and fittings previously manufactured for other programs are available for use to mate Customer's FGSE and fuelling station utilities.

Facility layout is shown below.

Fueling station 11G141

The station main building 101 is a four-storey facility accommodating a number of technological and office rooms (first, second and third floors). Fourth floor accommodates control room for work manager and fuelling equipment operators.



Fueling station 11G141

Building 101 has three major working areas:

- Hall 101 – SC and US fueling hall – 42x18x15,5 m;
- Hall 125 – cleaning area – 24x18x15,5 m;
- Hall 176 – reserved area – 18x18x15,5 m.

All working areas are divided with hermetical walls with swinging/sliding gates, 10x12 m. Same doors are at the facility ingress/exit, 10x12 m.

Rail tracks are available inside fuelling facility for cargo movement.

Electrical explosion-proof bridge cranes are available in Hall 101 for handling operations, capacity – 15 t, crane rails at 13,5 m, lifting height – 12,4 m.

Crane	Hook dimensions, mm				
	D	S	L	h	b
15 t (hall 101, bld. 101)	150	115	75	150	90

Crane speed:

Lift: Nominal – 2,4; MIN – 0,23 m/min;

Bridge: Nominal – 33,5; MIN – 2,12 m/min;

Trolley: Nominal – 11,1; MIN – 1,05 m/min;

Controls: wired, at floor level.

In the fuelling facility, the Customer will be provided with:

- Clean hall 101 for SC and GSE allocation for fuelling operations with cleanness class no worse than 100 000 as per Fed-Std-209E;
- Temperature inside hall 101 within 18 - 25°C;
- Relative humidity – 30...60%;
- Compressed gases:
 - Gaseous nitrogen;
 - Breathing air for SCAPE suits (upgrade required);
 - B-grade gaseous helium;
- Uninterrupted power supply (FS upgrade for specific requirement required);
- CCTV (fixed cameras at hall perimeter, no portable cameras available);
- EGSE grounding;
- Propellant vapor and waste collection and neutralization system;
- Water preparation system and FGSE decontamination system;
- Propellant vapor monitoring system and oxygen monitoring system;
- Phone lines (among launch site facilities, intercity, international) and facsimile;
- SC propellant temporary storage available;
- Venting;
- Emergency venting including absorber filters in case of gas contamination;
- Fire alarm systems (in technological and office areas);
- Fire fighting system;
- Emergency evacuation routes available (no emergency showers);
- Changing rooms;

- Office areas;
- Work area for work managers and controllers in the control room.

In case maximum permissible concentrations in Hall 101 are exceeded a sound and red light go on.

The system monitors and issues OFF-NORM signal for MPCx1 to MPCx10:

- N₂H₄, concentration measurement from 0,00005 mg/l, OFF-NORM signal at 0,0001;
- N₂O₄, concentration measurement from 0,001 mg/l, OFF-NORM signal at 0,002.

Oxygen contents in ambient air from 15 to 25%.

Hall 1 is equipped for operations with both fuels and oxidizers.

Fuel and oxidizer equipment is located on the right and on the left from rail tracks, respectively.

Vacuum equipment may be provided for FGSE decontamination. This equipment provides 0,5 mm Hg vacuum.

Compressed gases are supplied with pressure from 0 to 390 kgf/sm².

Vapors are confined into vapor neutralization system via leakproof lines.

Wastes are collected into propellant waste collection and neutralization system.

Vapor and waste neutralization is environmentally friendly and does not produce any toxic substances except exhaust from diesel-powered incinerators.

For the breathing air supply it is planned to use the equipment currently mounted at FS 11G12. This equipment is compliant with EN12021 and OSHA 1910.134 (1998) standards.

Distilled water (see parameters in table 3.4.3.5-3 below) for equipment flushing and hot nitrogen (30⁰C – 40⁰C) for drying will be provided.

Parameter	Value
PH	6
Chlorides	0,1 mg/l
Iron	< 0,05 mg/l
Sulphates	< 0,5 mg/l
Nitrates	< 0,1 mg/l
Evaporation residue	4,5 mg/l

Water will be supplied to Hall 101 under pressure of 3,5 and 4,5 kgf/sm². For higher pressures system upgrade is required.

Fueling equipment decontamination system supports water preparation to required parameters. Water quality will be supported with analysis and quality certificate.

Hot nitrogen supply is supported by nitrogen flow from receiver room to Hall 101 followed by heating up to 30-40⁰C.

Interface adapters and fittings previously manufactured for other programs are available for use to mate Customer's FGSE and fuelling station utilities.

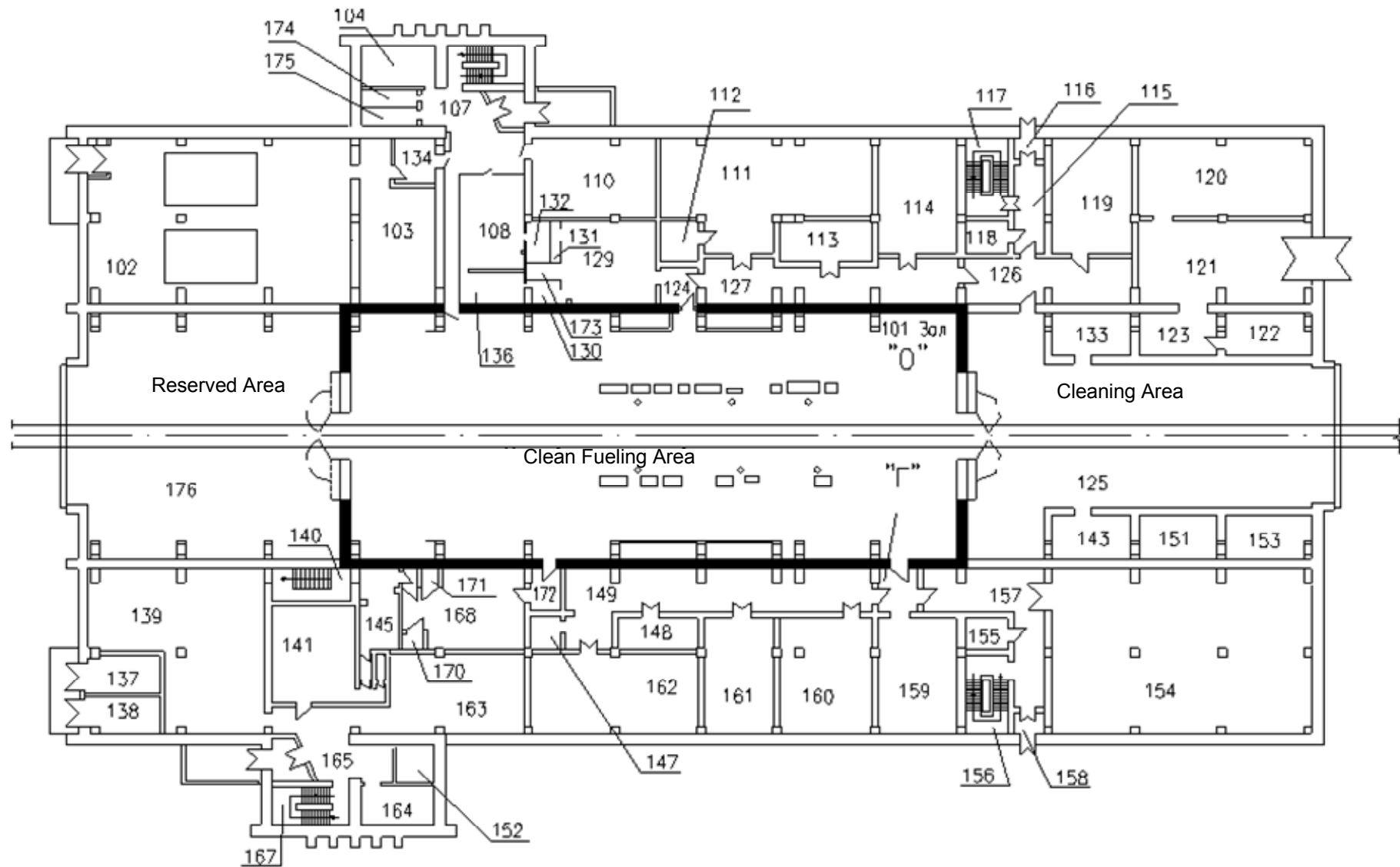
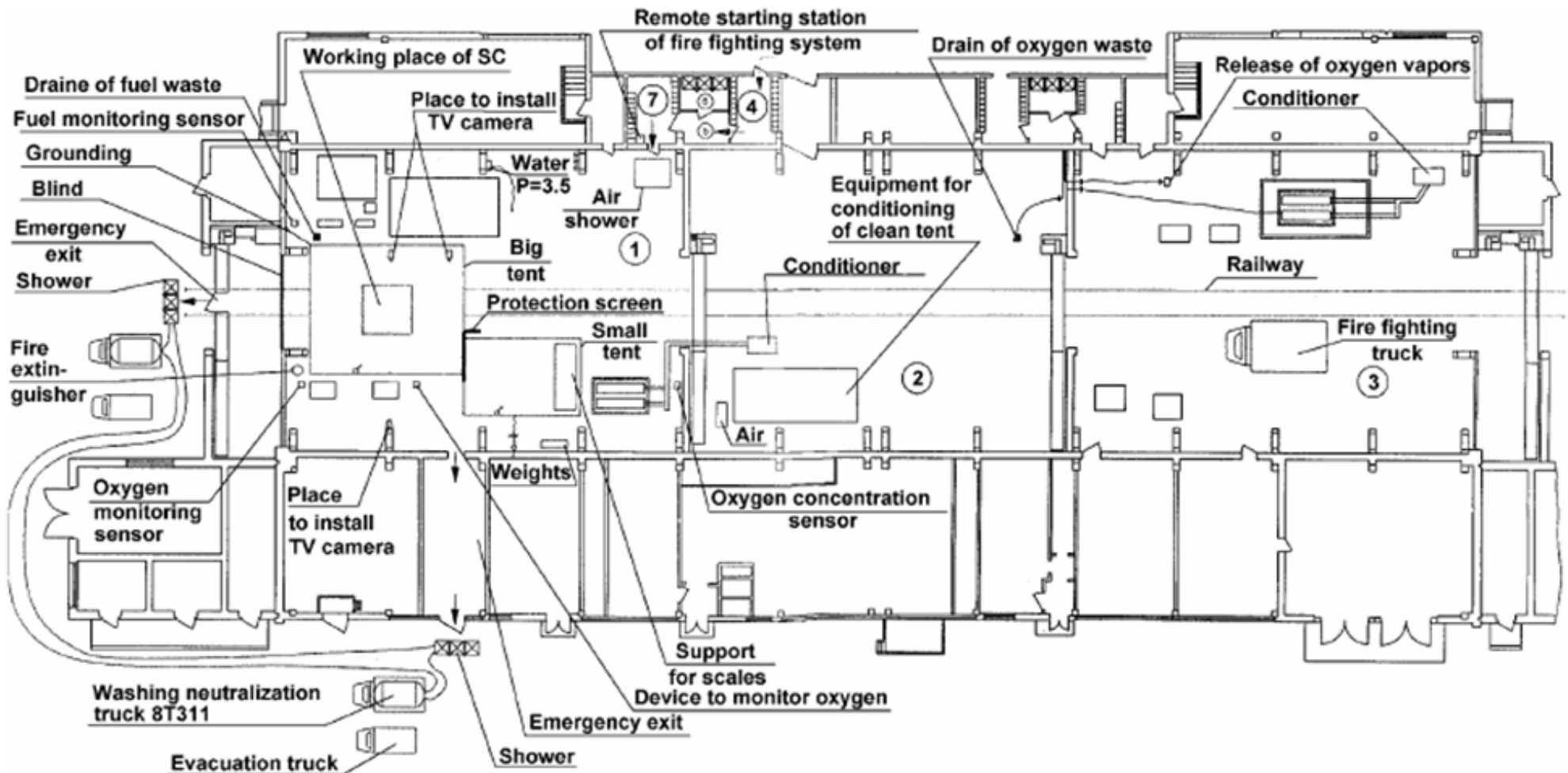

Figure 6-11 – FS 11G141 building 101 first floor layout



1 – Fueling Hall, 2 – Supercharge Hall, 3 – Oxidizer Loading Area, 4 – Changing Room, 5 – Airlock, 6 – Shower/First Aid Point

Figure 6-8. Hazardous Processing Facility, Building 44, Site 31

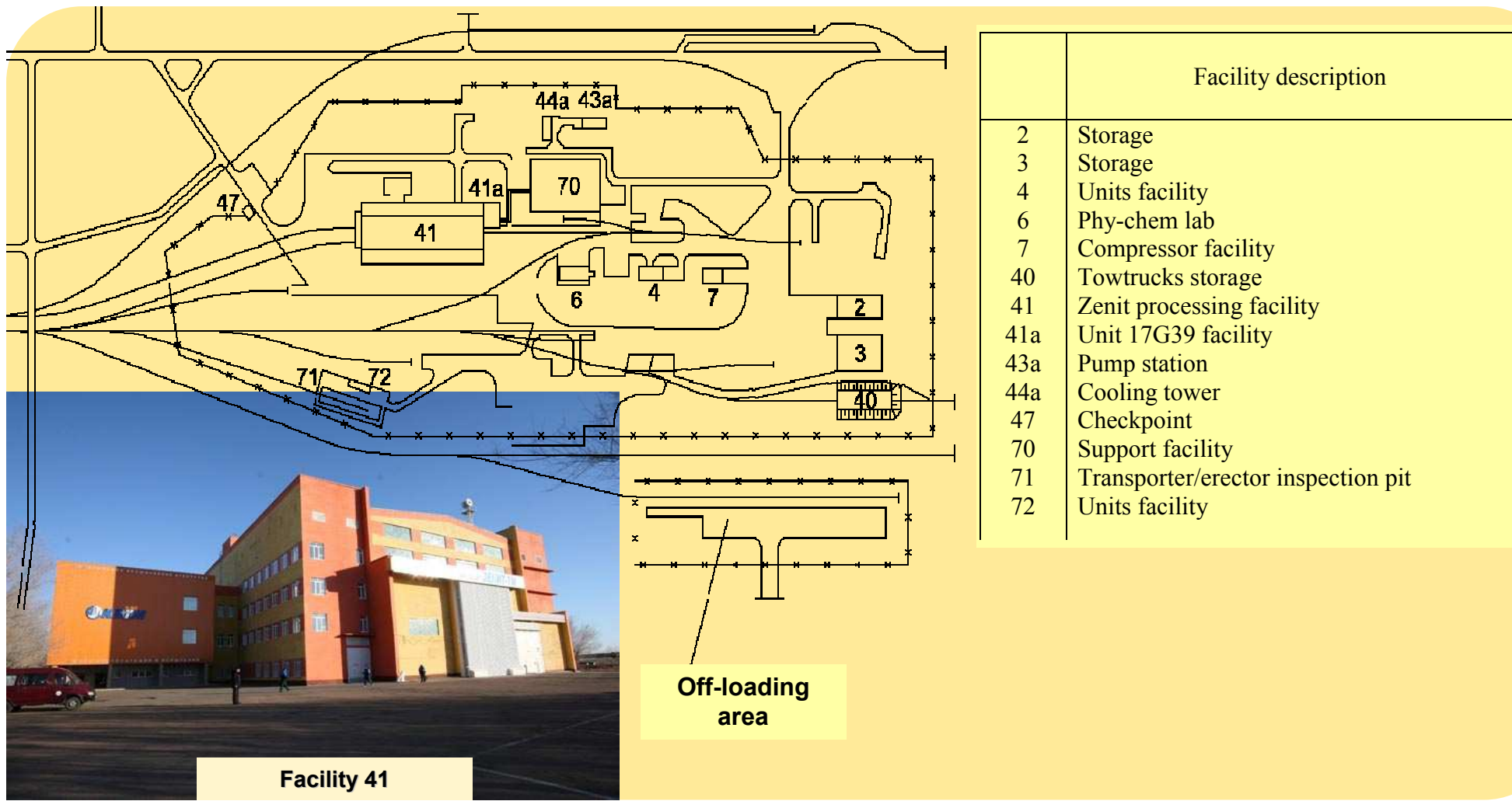

Figure 6-12 - Zenit-TM technical complex layout, site 42

6.5 LV and ILV Technical Complex – site 42

Overview

The general view of Zenit-TM technical complex is shown on figure 6.12.

Zenit-TM technical complex is located at Site 42. It includes launch vehicle processing facility, building 41 (see Figure -12.1) and is used for:

- Standalone integration and testing of the Zenit stages;
- LV mating with Ascent Unit and thereby forming integrated launch vehicle (ILV);
- ILV electrical checkouts;
- ILV loading onto the transporter/erector, prior to moving to the launch pad for launch.

The complex also includes office space for customer personnel and equipment room.



Figure 6-12.1 – LV processing working area and ILV assembly area at Zenit-TM complex, Site 42

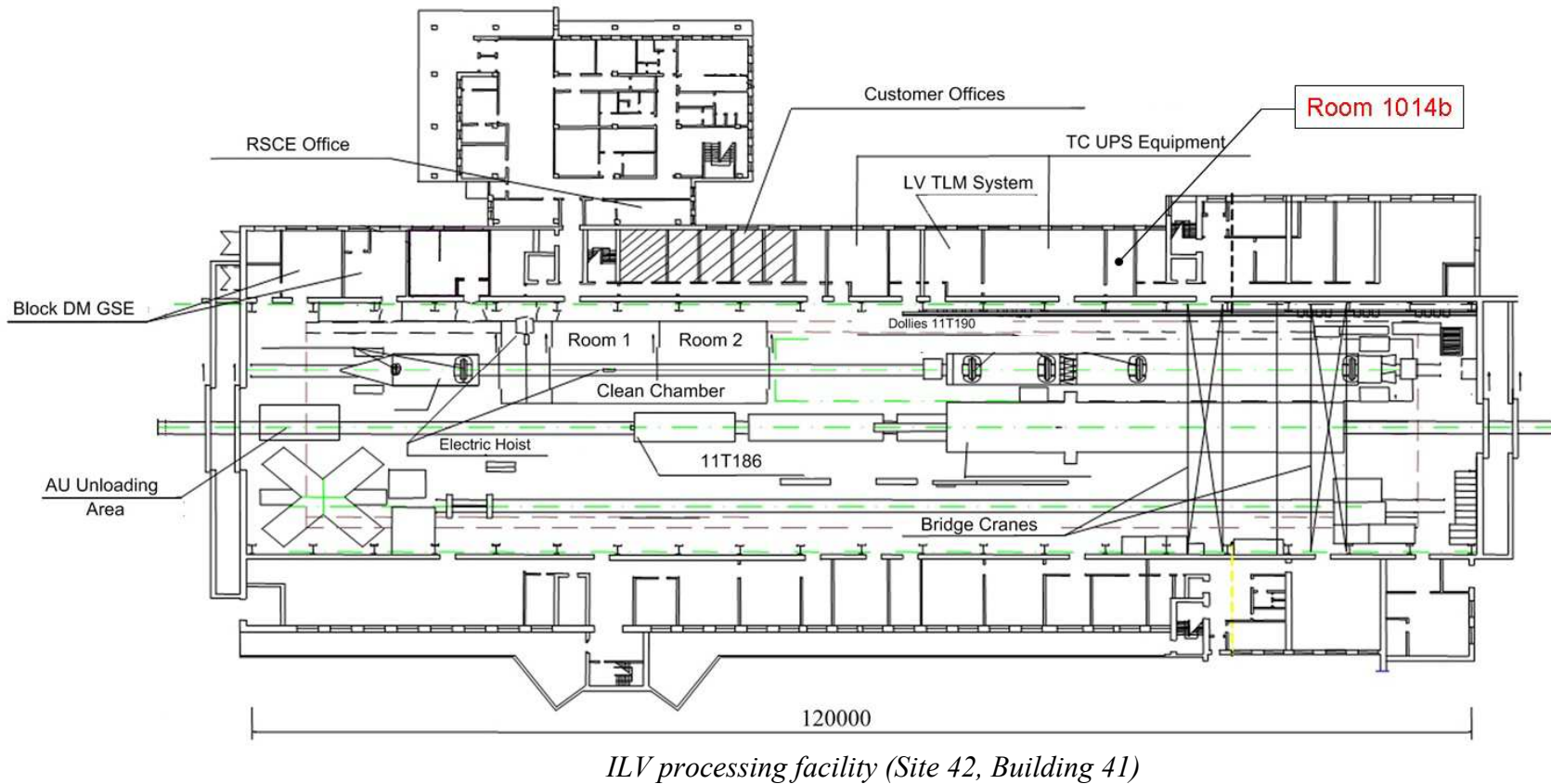

**Integration Area
Layout/Features**

Building 41 is 120 meters long and 60 meters wide, with three parallel sets of floor-mounted rails. The center rails are used for hardware delivery into and out of the building. The rails on the north side are used for launch vehicle integration operations, while the south rails are currently used for hardware storage. Two traveling bridges each have two cranes, with 50-tonne and 10-tonne capacities.

**Аппаратная
спутника**

An equipment room is available for customer use in Building 41, equipped with the power supplies and the umbilical connections to the spacecraft that are defined in Section 5. SC checkouts are provided using SC ESGE located in the ILV processing and integration hall (Building 41, Site 42) right next to Ascent Unit. SC battery charging may be performed at ILV processing facility, if required.

**Customer Office
Areas**

Air-conditioned customer office facilities are provided at in Building 41, Site 42. These facilities provide private office and conference space for resident spacecraft personnel teams. The customer is provided with local and international telephone communication, data links to Baykonur sites and worldwide.

6.6 Zenit Launch Complex (LC) – Site 45

Overview The general layout of Zenit-SM launch complex is shown on Figure 6-13. It consists of the launch pad, propellant and compressed gases storages, bunkered launch control complex and control equipment.

Launch Complex automated systems Launch operations are highly automated on Land Launch. This has many advantages including:

- inherent safety to personnel, since there is no need to physically approach the launch vehicle;
- high launch-on-time probability.

In case launch process experiences an anomaly requiring termination, it does so automatically, assuring safety of the launch vehicle, spacecraft, and launch complex. If required, launch vehicle detanking operations are also done remotely from the control post.

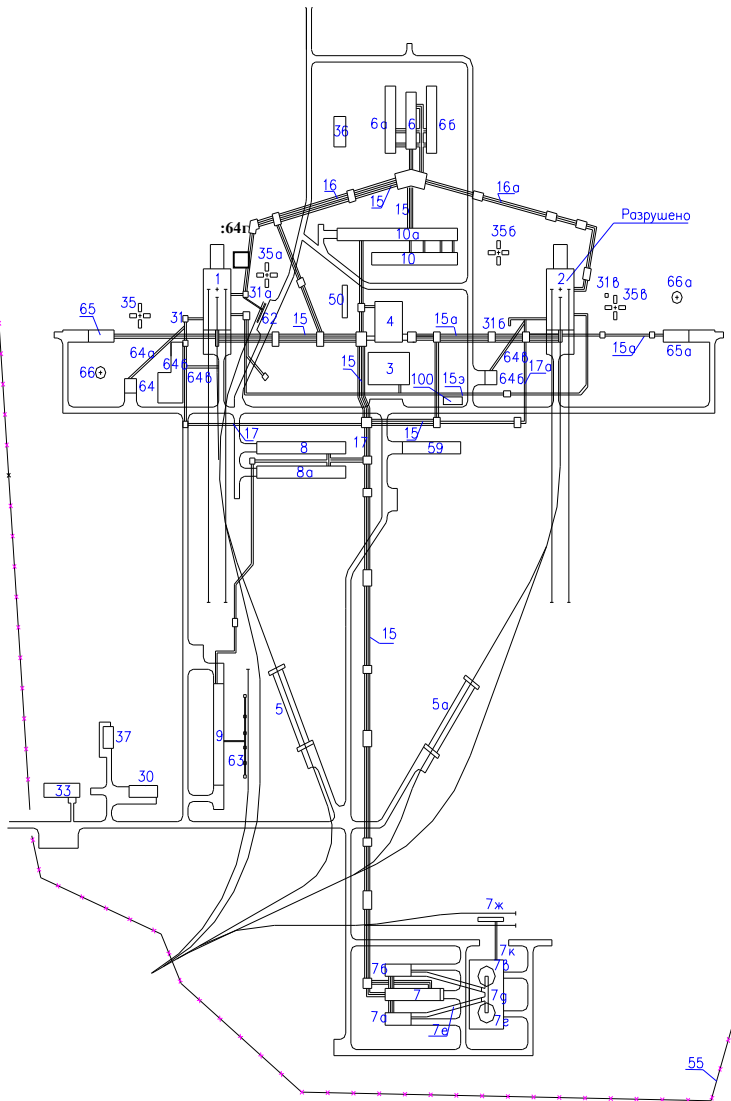

No.	Facility
1, 2	Launch pads no. 1, no. 2
3	Command post
4	Support facility
6	Fuel loading support facility
6a, b	Fuel storage
7	Oxidizer loading support facility
7a, b	Oxidizer pump stations
7c, d	Oxidizer storage
7e	Oxidizer evaporation system pad
7f	Oxidizer support system
7g	Oxidizer drain trays
7k	Drain trays support system
8, 8a	Bottle facility
9	Compressor facility
10, 10a	Temperature control station
15, 15a	Communication channels
15e	Emergency gallery (evacuation)
16, 16a	Fuel pass-through channel
17, 17a	Oxidizer pass-through channel
30	Washing station
31, 31a-c	Targeting system facility
33	Administrative and support building
35, 35a-c	Diverter, h+120m
36	Fuel waste facility
37	Water utility pump station
43	Fuel waste decontamination station
50	4-section cooling tower
55	Internal sharp-wire fence
59	Power unit
62	Fuel drain
63	Oxidizer drain
64	Oxidizer drain pad
64a	Drain pipelines
64b	Upper stage oxidizer storage
64c	Upper stage oxidizer drain trays
64d	Liquid oxygen fueling system
65, 65a	Special fire fighting pump station
66, 66a	Fire fighting tank
100	LC UPS location area

Figure 6-13. Zenit-SM launch complex layout, Site 45

**Customer EGSE
Room (Bunker)**

Umbilical connection to the spacecraft (described in Section 5) is provided via the cable mast connected to the Zenit second stage and is disconnected at lift-off of the ILV. RF connection to the spacecraft is done through RF windows in the fairing, and also described in Section 5.

The customer EGSE for connecting to these umbilical and RF links is positioned in room 114, an underground equipment room located near the launch pad (Figure 6-14), 10.5 meters long and 5.6 meters wide.

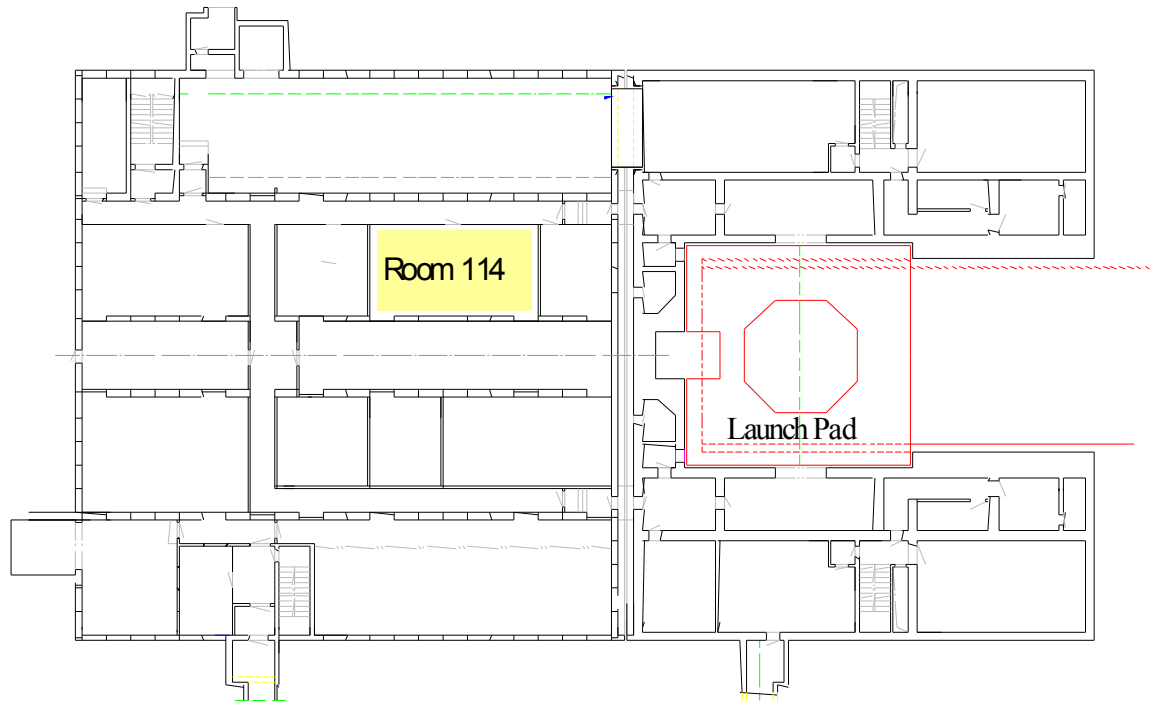

Figure 6-14. Location of Room 114 (Customer EGSE room)

Command Center During pre-launch and launch operations, SC personnel is located in the Control Center (CC) as shown in Figure 6-15. Customer room in the CC is equipped with:

- fire and environmental control systems;
- CCTV monitoring the launch pad and the ILV;
- Fiber-optic data link for connection to SC EGSE located in the bunker to control SC parameters during countdown;
- connections to the voice net for customer polling during countdown.

The CC is located two levels down inside a reinforced concrete underground building that provides protection for personnel during launch.

The LSP's RF system in the CC provides SC-to-SC EGSE RF link via both telemetry and command channels. Systems antennas are located on bunker's roof.

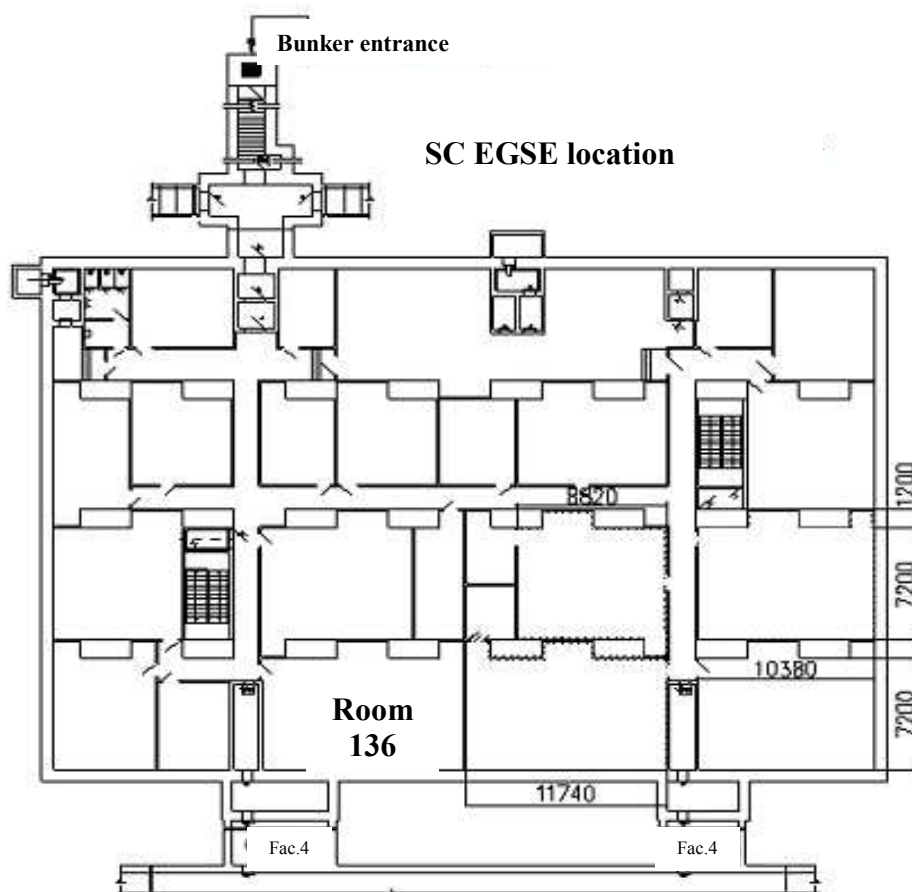

Figure 6-15. Customer allocation in the CC

6.7 Cosmodrome Amenities

Visa and Access Authorization	Land Launch supports Customers in obtaining entry visas to Russia. A double or multiple visa is required to travel to Baikonur cosmodrome. Land Launch also provides customer personnel with access to the launch site as well as badges to required facilities.
Customs clearance	Land Launch supports Customers in obtaining customs clearances at port of entry and exit located in Sheremetyevo airport in Moscow as required for the transport of spacecraft and associated GSE. According to the existing customs regulations SC and associated GSE delivery to Kazakhstan will be made as re-export mode. Administrative fees may be associated with customs clearance in Russia. If so, such fees are the customer responsibility. Any customs or export/licensing processes (export license authorization) in the Customer's country of origin for equipment and propellants are the responsibility of the Customer. The Customer is also responsible for providing all associated packing lists and invoices.
Transportation	All work-related transportation of Customer personnel and equipment is provided starting from arrival to the airport until departure from the airport. All vehicles are equipped with air-conditioning and heating systems. If necessary, additional vehicles (e.g., VIP transportation) may be rented in Baikonur. Upon request Land Launch can provide transportation to meet non-typical Customer needs.
Consumables	Customers will be provided with prepared water, ethyl alcohol, compressed nitrogen and helium, breathing air for SCAPE suits at SC processing area and at the fueling station. Customers must provide their own equipment such as isolating gas masks and portable air bottles for critical conditions.
Security	Around-the-clock security is provided to preclude access of unauthorized personnel to SC starting from SC arrival to the launch site airport through launch.
Schedules	Customers are provided with daily and weekly schedules. The typical working week is five days, Monday through Friday. Additional working time or other daily/weekly schedules can be arranged on a case-by-case basis.
External Communications	The customer will be provided with local and international telephone/facsimile communication, e-mail and Internet access, and access to dedicated ground and satellite international channels to transmit data between the launch site and SC Customer control center. Customers are encouraged to advise beforehand on the scope of telecom services required.
Medical Care	During the launch campaign, Land Launch provides continuous access to a medical staff that can provide treatment to any sick or injured personnel.

**Accommodations
and Dining**

Hotel accommodations are available at the Sputnik hotel (<http://www.sputnikhotel.com/>), located in the city of Baikonur, and on base in hotels at site 2Zh close to site 254. The Sputnik Hotel offers 120 comfortable rooms and five suites, one restaurant, bar, fitness center, conference hall, offices, swimming pool, sauna, gym, barber shop, mountain bikes and a variety of other amenities. Accommodations, dining and communication services in the hotel are Customers responsibility.

6.8 Doorway dimensions

- a) in buildings 40 and 40D, PPF (site 31):
- area B to room 119 – 5x7 m (h);
 - room 119 to 119A – 4x5 m (h);
 - room 119 to 119B – 2x3 m (h).
- :
- b) hallway to room 136, building 3, CC (site 45): 0,9x2,1 m (h);
- c) hallway to room 114, building 1, bunker (site 45):
- for equipment – 0,98x1,8 m (h);
 - for personnel – 1,5x2,1 m (h).
- d) in building 41, LV processing facility (site 42):
- hallway to room 1014B – 1,43x1,98 m (h);
 - processing hall to hallway – 1,21x1,98 m (h).

6.9 LAND LAUNCH STANDARD OFFERINGS AND OPTIONS

This section lists Land Launch standard offerings and options for:

- hardware and equipment;
- launch services;
- facilities and support services.

STANDARD-OFFERING HARDWARE

Launch vehicle	Zenit-3SLB, Zenit-3SLBF, and Zenit-2SLB
Payload Fairing (PLF) and Spacecraft Adapter (SCA)	<ul style="list-style-type: none">• PLF with access doors and RF windows.• SCA with compatible mechanical interfaces and separation system.
Customer logo	<ul style="list-style-type: none">• Logo provided by Customers shall be manufactured and supplied by LSP and shall be placed on the fairing.
RF interfaces	RF (command and telemetry) links between spacecraft and spacecraft electrical ground support equipment (EGSE) during operations including when the integrated launch vehicle is erect on the launch pad.
Hard-line interfaces	<ul style="list-style-type: none">• Umbilical connectors for telemetry and command links and SC power supply;• In-flight disconnect break wires as needed.

STANDARD-OFFERING LAUNCH VEHICLE PERFORMANCE

Orbit and mass • See section 3

Orbit accuracy • See section 3

STANDARD-OFFERING LAUNCH SERVICES

Mission management Mission Management includes program-level services, such as contracts, scheduling, program management, mission integration and launch operations.

Meetings and reviews • Customer kickoff meeting.
• Preliminary and final ICD review.
• Preliminary and Critical design reviews (PDR & CDR).
• Hardware production reviews.
• Ground operations working group meetings as required.
• Ground operations readiness review (ready to receive spacecraft).
• Spacecraft fuelling readiness review.
• Combined operations readiness review (ready to mate spacecraft to SCA).
• Ascent unit readiness review (ready to transfer ascent unit to LV integration facility).
• Roll-out readiness review (ready to move ILV to the launch pad).
• Launch readiness review (ready to launch).

Documentation

The following documents will be provided to each customer according to the mission integration schedule (developed by LSP with customer concurrence after mission identification):

- Mission integration schedule.
- Spacecraft/Land Launch ICD.
- Launch operations plan.
- Spacecraft operations manual.
- Master countdown procedure.
- Launch commit criteria.
- Matchmate plan.
- ICD requirements verification plan and schedule.
- Post-flight report.

**Mission
integration****Analyses**

The following analyses will be conducted. Unless noted otherwise, each analysis will involve two cycles (preliminary and final) for first-time integration, and one cycle for repeat integration.

- Mission design.
- Spacecraft shock analysis (one cycle for both first-time and repeat integration).
- Spacecraft acoustic analysis (one cycle for both first-time and repeat integration).
- Spacecraft separation analysis.
- Critical clearance analysis (dynamic).
- Coupled loads analysis.
- Pre-launch environmental control system analysis (nominal and abort scenarios).
- Flight thermal analysis.
- Venting analysis.
- Contamination assessment.
- EMC assessment.
- Spacecraft on-pad RF link analysis (one cycle for both first-time and repeat integration).
- Spacecraft/PLA clearance analysis (static).
- Customer SC and GSE safety package analysis.
- Post flight analysis (one cycle for both first-time and repeat integration).

Verification

Land Launch will perform verification of spacecraft requirements as defined in the ICD.

Separation state vector

A spacecraft separation state vector is normally provided to the customer within 50 min of separation.

Interface test

For each first-of-type spacecraft, Land Launch will perform a matchmate test at the spacecraft factory that includes the SCA and a flight equivalent separation system. Matchmate tests consist of mechanical and electrical interface testing between spacecraft and SCA.

STANDARD-OFFERING FACILITIES AND SUPPORT SERVICES

The following sections list the facilities and support services available to each Land Launch customer for the processing, assembly, installation, transportation, fueling and launch of their spacecraft. See section 6 for details.

Payload Processing Facilities (PPF)

Land Launch will assist the customer with unloading the spacecraft and GSE from the aircraft at the cosmodrome airport. Land Launch will provide for the transportation of this hardware and miscellaneous equipment from the airfield to the PPF. The PPF facilities are described in detail in the Land Launch Users Guide. Facilities at the PPF are available to the customer for approximately five weeks during the launch campaign. The activities and services at the PPF include:

- Spacecraft-to-spacecraft adapter touch & go.
- Spacecraft checkout and fueling.
- Encapsulation (AU integration).
- AU checkout.
- Control rooms.
- Remote or explosion-proof control rooms.
- Office space.
- Conference room.
- Environmentally controlled areas.

Customer operations may be performed and scheduled on a 24-hr basis with access to the customer office building and the PPF. All customer equipment must be removed from Land Launch facilities within three (3) workdays after the launch is completed. Following the launch, Land Launch will assist the customer and provide for the transportation of the GSE from the PPF to the local airfield.

**PPF
Communications**

The following communication services will be available to customer personnel during PPF operations:

- Intercom
- TV monitors and cameras
- Telephones with international access
- Launch video
- Countdown net
- Hand-held radios

PPF Security

- Twenty four hour perimeter security
- Security devices on all internal and external doors leading to the payload processing areas
- Twenty four hour electronic monitoring for ingress and egress, and smoke and fire detection

**PPF support
services**

- Separate technical and facility electrical power.
- Use of clean room compatible mechanical support equipment (e.g., man-lifts and forklifts).
- Contracted quantities of gaseous nitrogen, liquid nitrogen, gaseous helium, isopropyl alcohol, and other general-purpose cleaning agents and solvents.
- Hazardous vapors detection and monitoring system.
- Receipt and staging of spacecraft propellants.
- Use of calibrated weights.
- Photocopier and facsimile machines

**Launch Vehicle
Integration
Facility, Area 42**

Land Launch will provide facilities for personnel and spacecraft GSE in the LV integration facility, Area 42, for spacecraft check out and battery charging if required. Land Launch will provide power and conditioned air to the spacecraft. Land Launch will assist the customer during transfer and installation of spacecraft GSE from the PPF to Area 42. Typical spacecraft tasks are:

- Spacecraft battery charging.
- Spacecraft/Launch Vehicle umbilical line validation.
- Spacecraft check out.

Launch Complex (LC) Facilities, Area 45

Land Launch will provide LC facilities for customer personnel and spacecraft GSE. Land Launch will provide the following services:

- Power.
- Thermostating air.
- RF link from the spacecraft to spacecraft GSE.
- Assistance in installing GSE in a customer GSE room.
- Assistance in SC/LV umbilical line validation.
- Launch complex safety training.

Launch Complex Communications

The following communication links are available within the launch complex, area 45:

- Intercom (including countdown net)
- TV monitors and cameras (including launch video)
- Dedicated telephone lines to international circuits

Launch Complex, Area 45, Security

- Full time security for the spacecraft and GSE.
- The facilities have 24-hr electronic monitoring for smoke and fire detection.

Environmental control

Land Launch will maintain spacecraft environments within the limits specified in the Spacecraft/ Launch Vehicle Interface Control Document (ICD) while the spacecraft is in the Payload Processing Facility, encapsulated within the ascent unit payload unit, during transit to and at the launch vehicle integration complex, transit on the ILV to the launch pad, erection to vertical, and final countdown and launch.

Range Services

Land Launch will coordinate with the customer and submit all required range documentation for the launch of the customer's spacecraft. Land Launch will provide all necessary telemetry assets to verify launch vehicle functions and conditions from lift-off to spacecraft separation.

Logistics Support

- Accommodations and meal services: Land Launch will make hotel reservations, and make meal services available for the customer team during working hours on base.
- Clinic first aid;
- Daily transport between hotel and Cosmodrome facilities.
- Translator service.

Weather service support

- Customer shall inform Land Launch on the maximal permissible values for weather conditions at earth surface and at altitudes that restrict operations at all steps of ILV processing and launch.
- Land Launch will provide weather service support as per requirements of ILV operational documentation and Master Countdown Procedure.

OPTIONAL SERVICES

The following services can be provided by Land Launch on customer request. These services are considered optional and are subject to negotiation. Requests for other services, not described in this document, will be considered by Land Launch on a case-by-case basis.

- Mission Analyses** Repeating any analysis listed or any additional analysis or design work due to changes made by customer special request.
- Interface tests**
- Matchmate testing at the spacecraft factory for repeat of spacecraft type.
 - Separation shock test.
- Support Services**
- Photo and video service;
 - Launch live coverage to Customer's website in real-time.
 - Additional medical services.
 - Air tickets booking and purchase including charter flights for personnel and/or spacecraft parts.
 - International calls payment based on actual bills; Internet in the hotel.
 - Armed guards for customer personnel during transportation from the hotel to launch site and back.
 - Armed guards for customer personnel at hotel's perimeter.
 - Customer GSE storage at the launch site beyond three days after launch.
 - Customs support in case of combined GSE backhaul after launch (by air and/or rail and/or automobile transport).
 - Staged GSE entry to Baykonur and/or staged backhaul from Baykonur.
 - Organization of Moscow-Baykonur-Moscow charter flights.
 - Internet access in the hotel.
 - Customer operations support in case of off-nominal situations (customer personnel transportation to crash site, SC debris recovery, accommodation, catering, communication for customer personnel, organizational and legal support in interfacing state and local authorities, etc.).

Consumables

- Helium grade A
- SC umbilical connectors purchase for SC and SCA, and other electrical connectors needed for manufacturing of Customer GSE connection cables at the launch site for a specific mission.

6.10 LAUNCH SITE GROUND SUPPORT EQUIPMENT INTERFACES AVAILABLE FOR CUSTOMERS

This section describes Land Launch standard interfaces available.

Ground support equipment interfaces for a specific spacecraft will be defined in the ICD for that specific spacecraft.

GROUND SUPPORT EQUIPMENT INTERFACES AT BAYKONUR AIRFIELD

The main standard interfaces of ground support equipment used for Customers SC and GSE containers offloading from aircrafts and transportation from Baykonur airfield to PPF are described below

Off-loading operations at the airfield





SC reloading onto rail car



SC GSE container off-loading

The following equipment is provided for SC and GSE containers off-loading from aircrafts and transferring them onto transportation means for moving to Baykonur facilities::

- Rail flatbeds (4 units).
- Rail car with lighting fixtures and gauge frame.
- A dedicated motor vehicle.
- Mobile thermostating car.
- 5 t fork-lift.
- 15 t fork-lift or automobile crane of sufficient capacity for GSE containers transfer.
- Automobile crane of sufficient capacity for SC container transfer.

**SC container
climate support**

In case environment control is required inside SC container during transportation the thermostating car may be used. For this, the SC container shall be equipped with inlet/outlet flanges having interfaces as shown on the figure below.

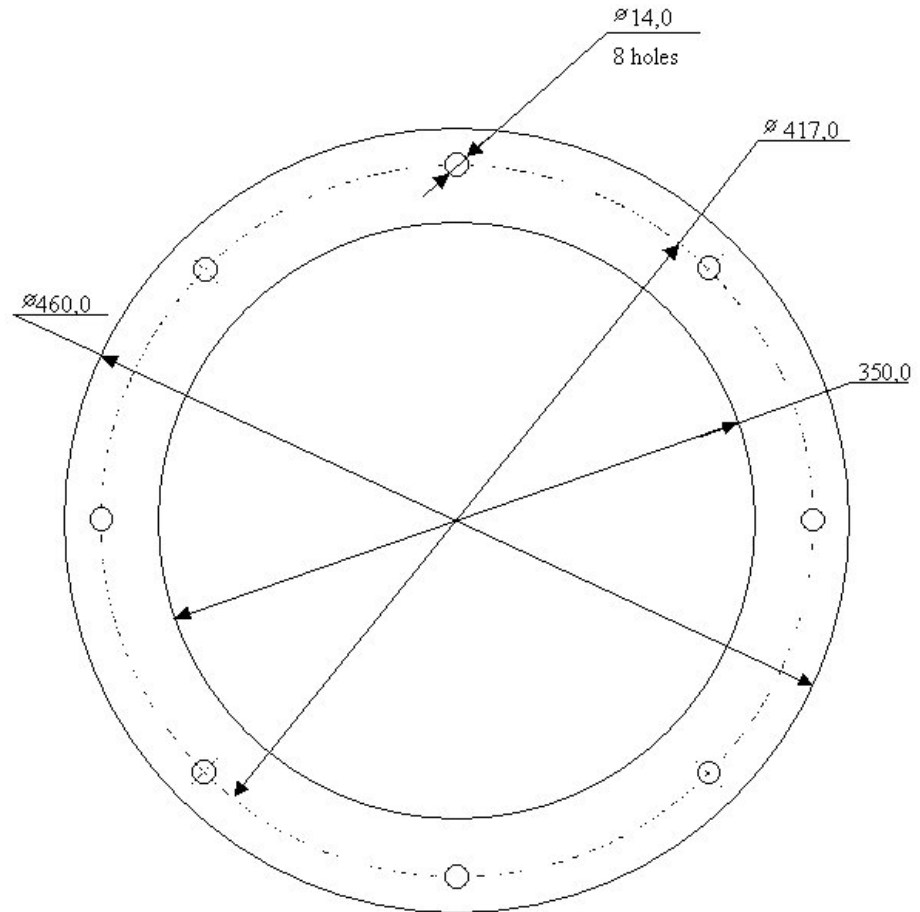

GROUND SUPPORT EQUIPMENT INTERFACES AT PPF (SITE 31)

The main standard interfaces of ground support equipment used in the PPF are described below.

Electrical interfaces

Locations of available Customer electrical interfaces in PPF Rooms 119, 119A and 119B, in Area A and B, building 40/40D, are shown below.

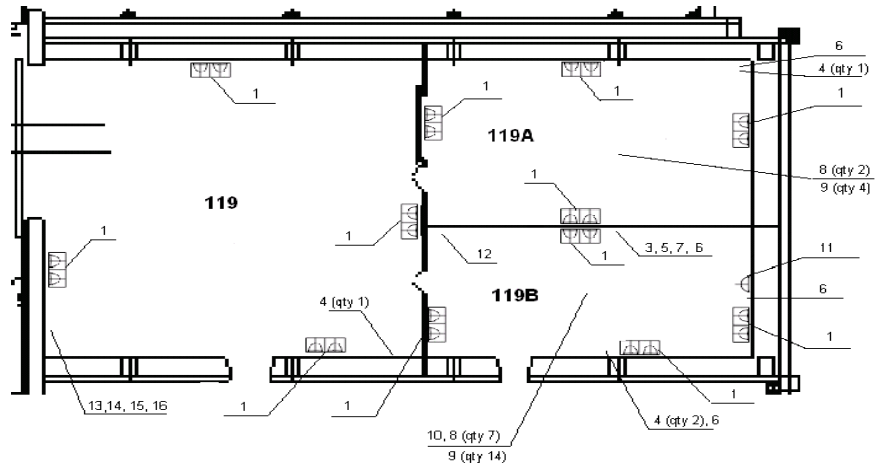

WT	type	description	qty	location
1	NEVA 5-20R	120V/50-200A	2	Janitor Room
1	NEVA J21 120	208V/50-200A	3	Janitor Room
5	E-15	Phone	4	Indic Area A
4	Interface Telephone		4	
8	S	Phone Out	8	Indic Area A
6	50 Ohm BNC Female	Internet	8	2 per location
7	RF		2	Indic Area A
8	Tables		10	
9	Redded Chairs		14	
10	Video Cam		1	
11	Chassis Inlet	AV/SC/PT/CA	1	
12	Video Monitor		1	located from Room 119, Area A - Indic Table
13	4000A Helium			
14	35 Mhz Range		1	
5	CEM4 50		1	
16	Helium Discharge Indicator		2	

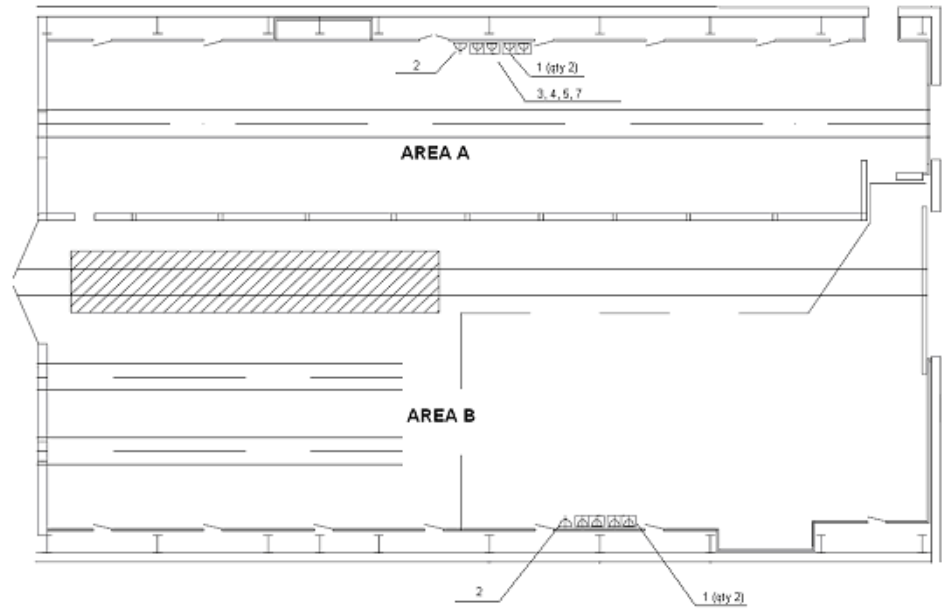

ref	type	description	qty	comment
1	NEMA 5-20R	120V/60Hz/20A	4	Uninterrupted
2	NEMA L21-30	208V/60Hz/30A	2	Uninterrupted
3	RJ45	Ethernet	2	Link to Room 119B
4		International Telephone	1	
5	ST	Fiber Optic	8	Link to Room 119B
6	RJ45	Internet	0	
7		RF	2	Link to Room 119B
8		Tables	1	
9		Padded Chairs	1	

To satisfy Customer needs, the locations of electrical interfaces may be changed, if required.

Gas supply system interfaces Location of gas supply system interfaces in building 40D.

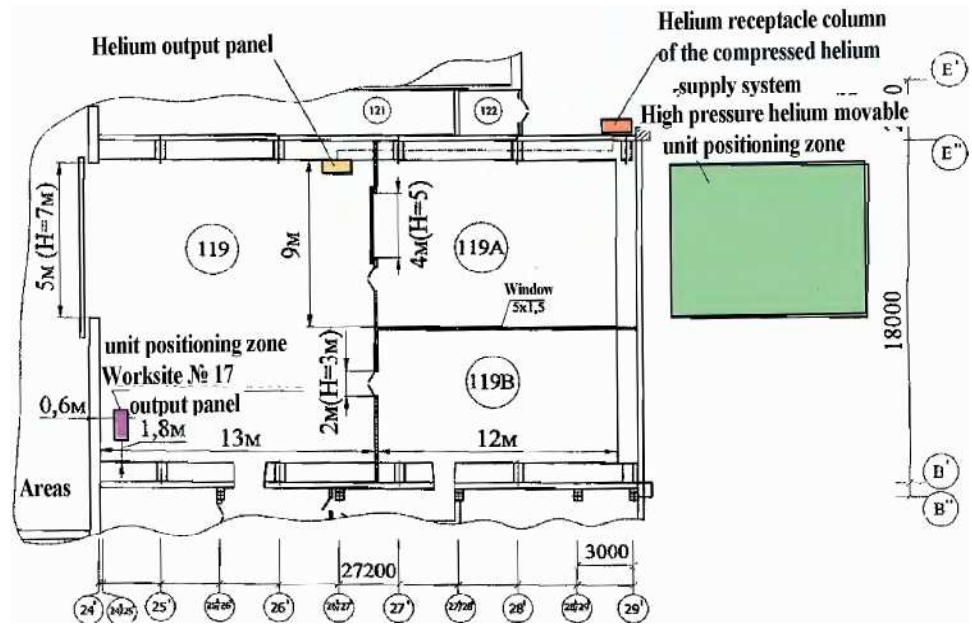

Crane parameters in PPF/AUPF

Building 40 (AUPF) is equipped with two bridge cranes having two hooks each. Hook dimensions are given in the table below. Both cranes are capable of servicing areas A, B, and C:

- Lifting capacity:
 - main hook - 50 t;
 - auxiliary hook - 10 t;
- Lifting speed:
 - main hook - 0,63 m/min and 6,2 m/min;
 - auxiliary hook - 0,94 m/min and 12,1 m/min;
- longitudinal motion speed - 1,76 m/min and 3,8 m/min;
- lateral motion speed - 0,96 m/min and 11,4 m/min;
- Lifting height:
 - main hook - 13,6 m and 14,0 m
 - auxiliary hook - 15,344 m and 15,330 m

Room 119, building 40D is equipped with a bridge crane with parameters listed below:

- Lifting capacity - 5 t;
- Lifting speed - 0,245 m/min and 2,1 m/min;
- longitudinal motion speed - 2,7 m/min and 25 m/min;
- lateral motion speed - 1,45 m/min and 13 m/min;
- hook height - 8,1 m (7,82 m considering drip shields).

Cranes in Area A and B are equipped with drip shields 1800 mm in diameter. Crane in room 119 is equipped with drip shield 2000 mm in diameter. Crane hook dimensions in buildings 40 and 40D are shown below.

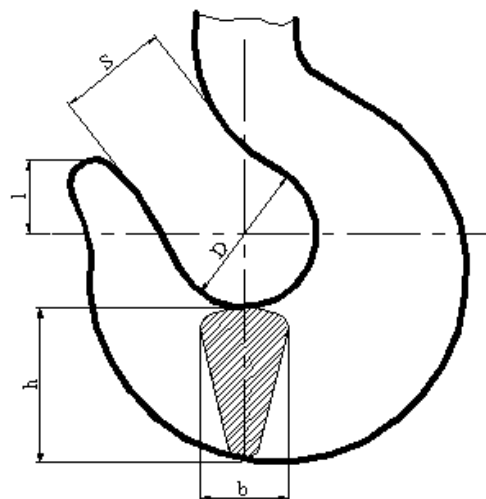

Crane	Hook dimensions, mm				
	D	S	l	h	b
5,0 t (room 119, building 40D)	85	65	42	82	54
10,0 t (AUPF, building 40)	120	90	60	115	75
50,0 t (AUPF, building 40)	270	205	135	260	165

SC TRANSPORTATION EQUIPMENT INTERFACES AND FUELING FACILITY INTERFACES

SC moving between launch site facilities

The main standard interfaces of ground support equipment used for SC transportation and in the Hazardous Processing Facility (HPF) are described below.

LSP will provide 3F-KST container for SC transportation between PPF and HPF. The container is rigidly fixed to a rail car. Maximal transportation speed is 5 km/h. SC will be accommodated vertically on a support frame mounted to container's floor.

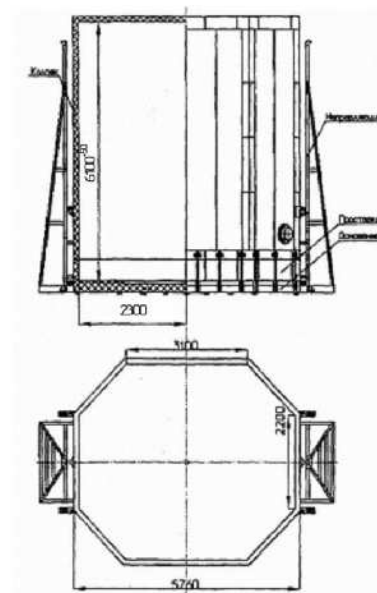

SC will be attached to container's floor using an intermediate frame or ring supplied by Customers. Container floor interface is shown below.

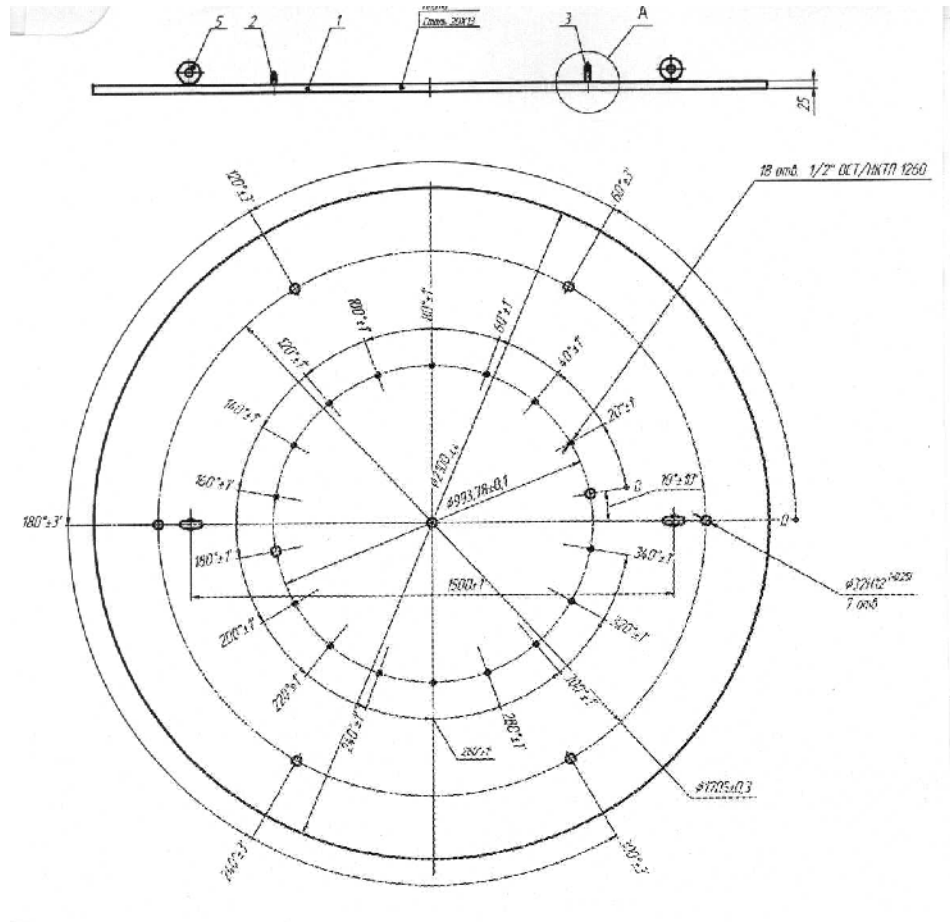

Power supply, gas supply, Ethernet interfaces

Allocation of HPF interfaces is shown below

TO BE ISSUED LATER

**11T715M
Container**

11T715M container will be used for SC transportation between PPF and HPF. The container is rigidly fixed to a rail car via a tilter device (see figure below). Maximal transportation speed is 5 km/h. SC and SC support frame will be accommodated vertically on the floor-mounted tilter and will be tilted horizontally for transportation as shown on figure below, and then will be tilted back to vertical for off-loading. Maximal tilting speed is 5 deg/min. The tilter/enclosure will also provide the following:

- Tilter mating interface,
- Clean conditioned air supply inside with no direct impact on spacecraft,
- Grounding interface similar to facility grounding,
- Access doors for personnel to get inside;
- Flat area 300 mm x 600 mm next to sc lower butt-end to accommodate required Customer equipment (150 mm high, 10 kg);
- Environment monitoring and recording.

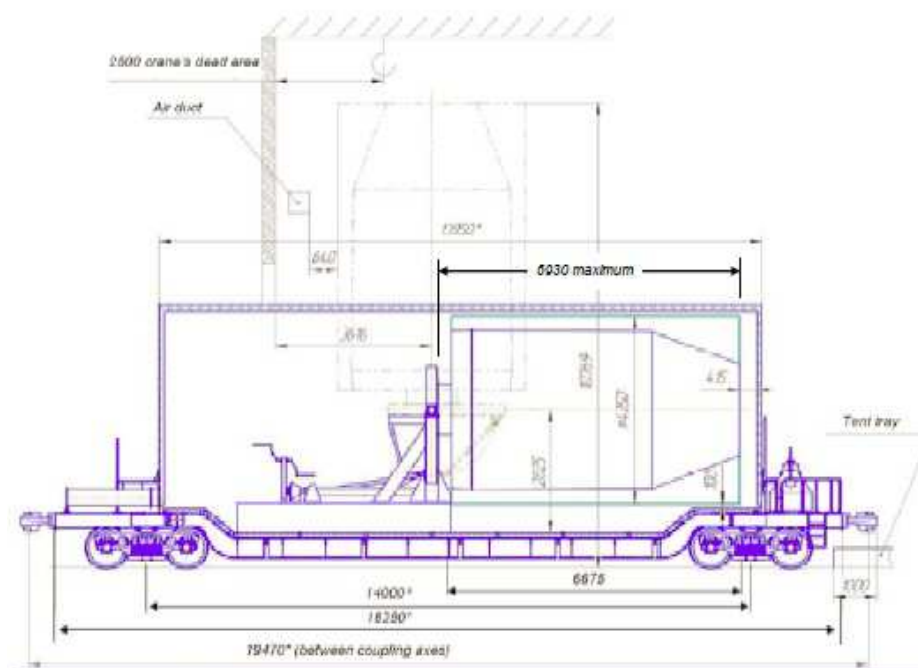

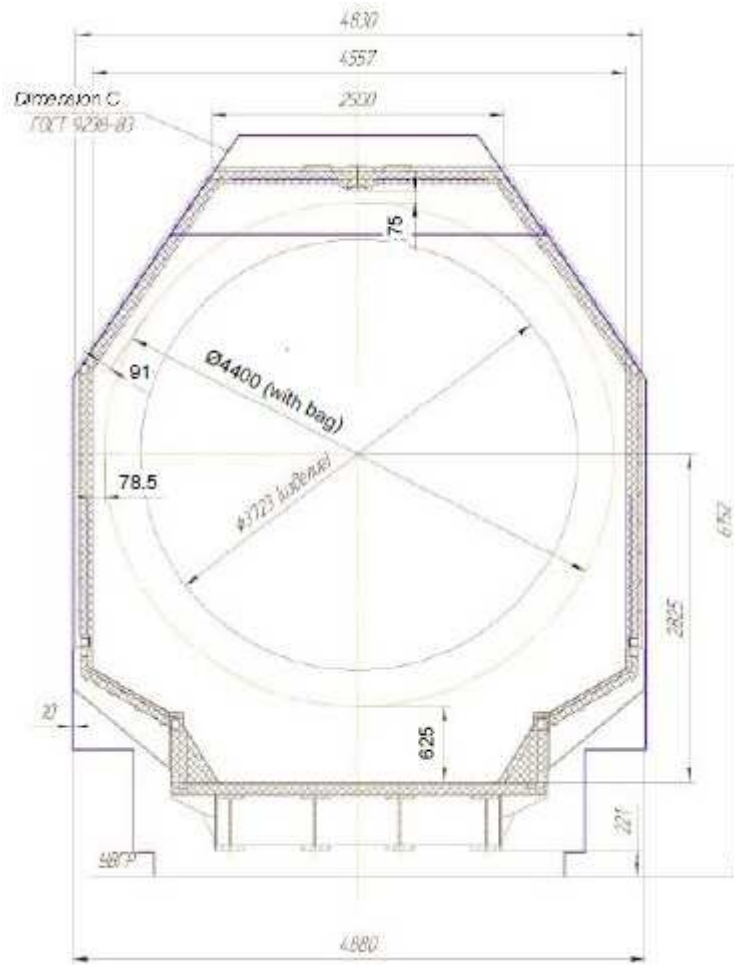

A-A

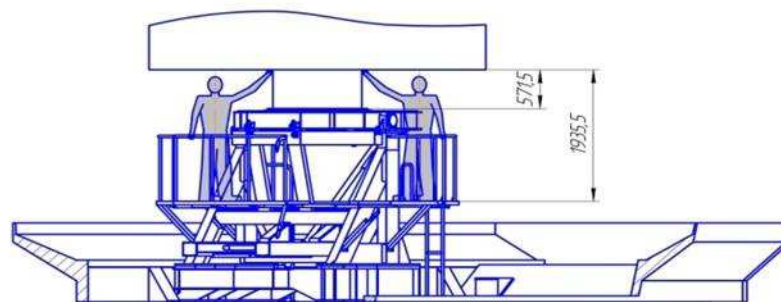

**HPF crane
parameters**

At the HPF Customers will be provided with bridge crane (with wired crane controls at the floor level) with the following parameters:

Lifting capacity - 15 t;

hook motion speed:

nominal – 2,4 m/min;

minimal – 0,23 m/min;

dolly motion speed:

nominal – 11,1 m/min.;

minimal – 1,05 m/min.;

crane motion speed:

nominal – 33,5 m/min;

minimal – 2,12 m/min.

The crane is equipped with drip shield.

GROUND SUPPORT EQUIPMENT INTERFACES AT LVPF (SITE 42)

The main standard interfaces of ground support equipment used in the Launch Vehicle Processing Facility (LVPF) are described below.

Electrical interfaces

Allocation of Customer electrical interfaces is shown on below.

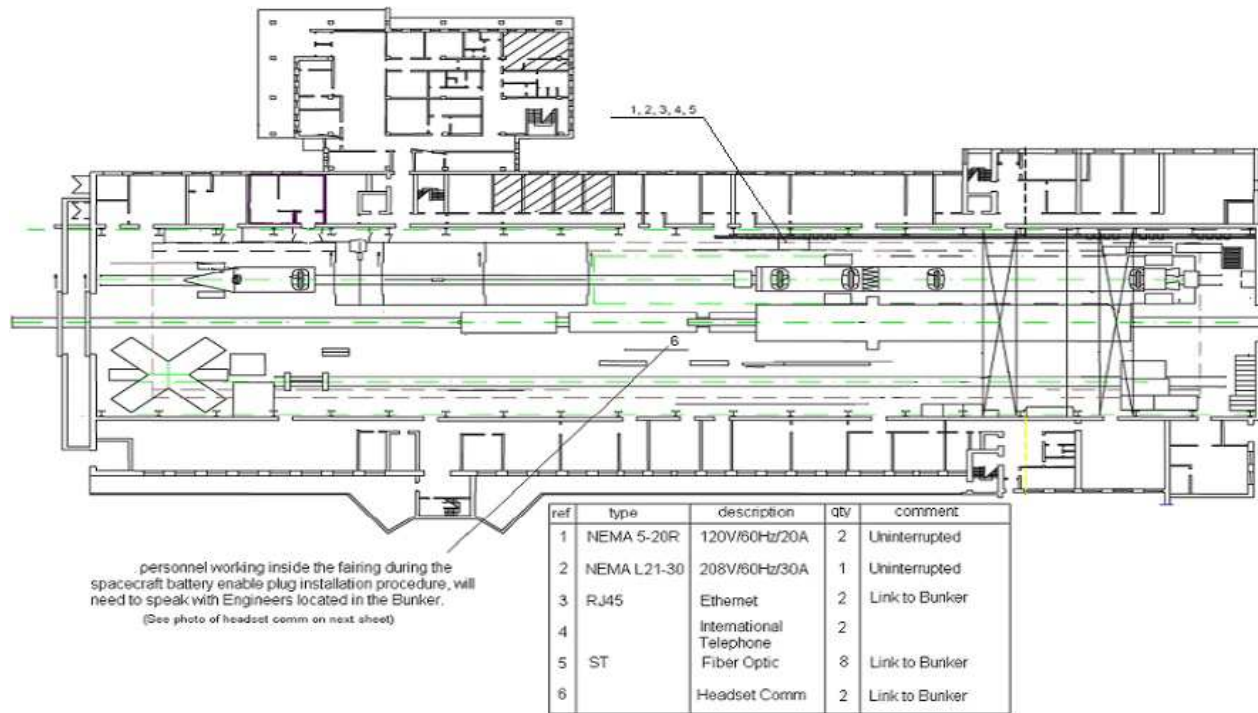

LVPF crane parameters

For off-loading of the Acsent Unit and SC GSE delivered from PPF, Site 31 bridge cranes will be used. Crane parameters are:

Lifting capacity:

- main hook - 50 t
- auxiliary hook - 10 t

Lifting height:

- main hook - 15 m
- auxiliary hook - 18 m

Lifting speed:

- main hook:
 - minimal - 0,63 m/min
 - maximal - 6,2 m/min
- auxiliary hook:
 - minimal - 0,94 m/min
 - maximal - 2,1 m/min

Longitudinal motion speed:

- minimal - 1,76 m/min
- maximal - 33,8 m/min

GROUND SUPPORT EQUIPMENT INTERFACES AT THE LAUNCH COMPLEX (SITE 45)

The main standard interfaces of ground support equipment used at the launch complex, site 45.

Electrical interfaces

Allocation of Customer electrical interfaces in building 3, site 45 is shown on below.

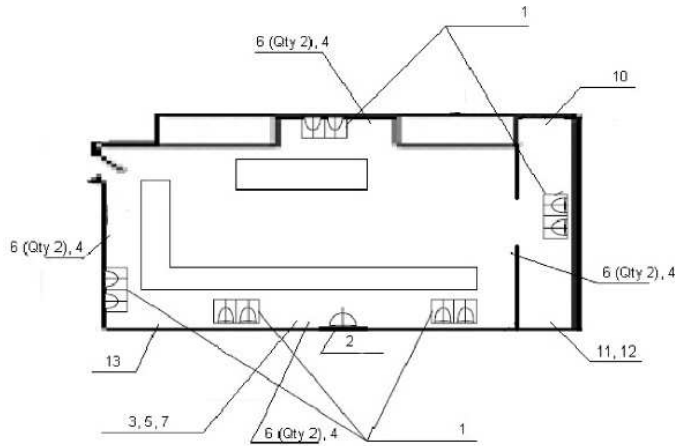

1	NEMA 5-20R	120V/60Hz/20A	5	Uninterrupted
2	NEMA L21-30	208V/60Hz/30A	1	Uninterrupted
3	RJ45	Ethernet	4	Link to ILV and Catacomb
4		International Telephone	4	
5	ST	Fiber Optic	16	Link to ILV and Catacomb
6	RJ45	Internet	8	
7		RF	2	Link to Launch Pad
8		Tables	7	
9		Padded Chairs	14	
10		Copy / Fax	1	
11		Refrigerator	1	
12		Microwave Oven	1	
13		Headset Comm	2	Link to ILV

Allocation of Customer electrical interfaces in building 1, site 45 is shown on below.

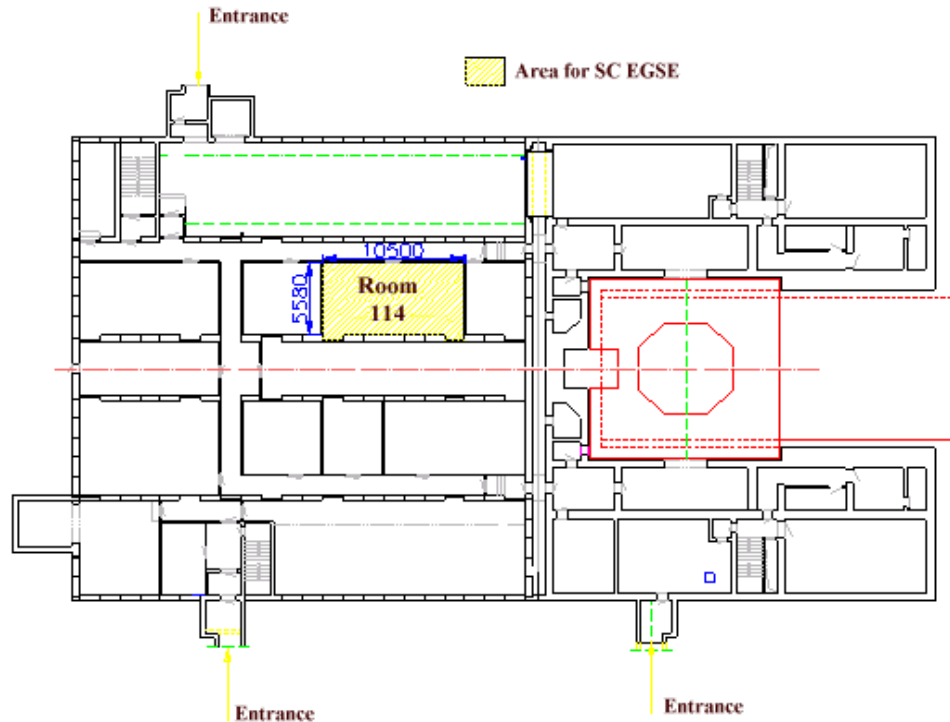

ref	type	description	qty	comment
1	NEMA 5-20R	120V/60Hz/20A	2	Uninterrupted
2	NEMA L21-30	208V/60Hz/30A	2	Uninterrupted
3	RJ45	Ethernet	2	Link to Bunker
4		Local Telephone	1	
5	ST	Fiber Optic	8	Link to Bunker

Transportation of Customer EGSE to the launch complex

EGSE is transported from LVPF (or from PPF/AUPF) to the launch complex using trucks. It is off-loaded from the truck right next to entrance to building 1 (launch facility) using automobile crane. (10 t capacity) of fork-lift (5 t capacity). Next, it is moved to room 114 via a hermetic door 1,8 m x 0,98 m.