

# 700 Series

## Encrypted Digital UHF Wireless System



**Includes:**  
**UDR700**  
**UM700**  
**UT700**



Fill in for your records:

Serial Number:

Purchase Date:

# Table of Contents

<b>Introduction</b> .....	<b>5</b>
Overall System Design .....	5
UDR700 Block Diagram .....	5
UDR700 Encrypted Digital Receiver .....	5
Rota-Versity™ Reception .....	5
RF Section .....	5
Digital Demodulator .....	6
Digital Signal Processing .....	6
Audio Output .....	6
UM700 Block Diagram .....	6
Encrypted Digital Transmitters .....	6
DSP-Controlled Dual Envelope Analog Limiter .....	6
Digital Signal Processing and Modulation .....	7
Transmitter RF Output Section .....	7
Long Battery Life .....	7
UT700 Block Diagram .....	7
Frequency Agility .....	7
Antenna .....	7
UT700 Microphone Element .....	7
<b>Comparing Diversity Reception and Rota-Versity™</b> .....	<b>8</b>
SmartDiversity™ .....	8
Rota-Versity™ .....	8
<b>The 700 Series Encryption System</b> .....	<b>9</b>
Level 1 .....	9
Level 2 .....	9
Level 3 .....	9
<b>UDR700 Controls and Functions</b> .....	<b>11</b>
UDR700 Front Panel .....	11
RF Level Indicator .....	11
Transmitter Audio Level .....	11
Information and Status Display .....	11
Menu Button .....	11
Select Up/Down Buttons .....	11
Rota-Versity™ Switch .....	11
Antenna Phase Combining Indicator .....	11
Power Switch .....	11
Security Jack .....	11
Audio Monitor Level .....	11
Audio Monitor Jack .....	11
UDR700 Rear Panel .....	12
AC Power Supply .....	12
EXT Power Connector .....	12
Analog Audio Output Control .....	12
GND/LIFT Switch .....	12
Phase 0/180 .....	12
Digital Audio Output - AES-3id .....	12
Antenna Jacks .....	12
UDR700 Information and Status Display Menus and Functions .....	12
Power Up Sequence .....	12
Enabling and Disabling the Buttons .....	12
Menu Interface .....	13
Main Tuning Menu .....	13
TV Tuning Menu .....	13
Group Tuning Menu .....	13
AES Output Menu .....	13
Security Menu .....	13
Key Generation Menu .....	13

<b>UM700 Controls and Functions</b> .....	<b>14</b>
Input Jack .....	14
Power On/Off Switch .....	14
Power LED .....	14
Frequency Select Switches .....	14
Audio Level Control .....	14
Modulation LEDs .....	14
Antenna .....	14
Adjustable Low Frequency Roll-Off Control .....	15
The Belt Clip .....	15
UM700 Battery Installation .....	15
<b>UT700 Controls and Functions</b> .....	<b>16</b>
Power On/Off Switch .....	16
Power LED .....	16
Hiding the Power LED .....	16
Encryption Key Link .....	16
Frequency Select Switches .....	16
Modulation LEDs .....	17
Audio Level Control .....	17
Locked Mode .....	17
UT700 Battery Installation .....	17
<b>System Installation and Operating Instructions</b> .....	<b>19</b>
System Setup .....	19
Changing the Security Level .....	22
Setting the Encryption Key .....	22
Protecting the Encryption Key .....	23
UT700 Vari-Mic™ Controls .....	23
Bass / Mid / Treble (LO / MID / HI) .....	23
Preamp Level Control .....	24
Bass Filter .....	24
5-Pin Input Jack Wiring (UM700) .....	24
RF Bypassing (UM700) .....	25
Line Level Signals (UM700) .....	25
Encryption Key Cables .....	25
<b>Troubleshooting</b> .....	<b>27</b>
Power Problems .....	27
UDR700 .....	27
UM700 .....	27
UT700 .....	27
RF Problems .....	27
Audio Problems .....	28
<b>Specifications</b> .....	<b>30</b>
Overall System .....	30
UDR700 Digital Receiver .....	30
UM700 Digital Transmitter .....	30
UT700 Digital Transmitter .....	30
<b>Replacement Parts and Accessories</b> .....	<b>32</b>
<b>Service and Repair</b> .....	<b>33</b>
Returning Units for Repair .....	33
<b>Microphone Cord Termination</b> .....	<b>34</b>



# Introduction

The 700 Series encrypted digital wireless microphone system uses a digital audio chain and an encrypted digital RF communications link for excellent sound quality and data security. The applications for this system include high-end motion picture, studio and stage, and boardrooms, courtrooms and conference rooms where security is a concern. While these applications are very different from one another, this single system is able to provide significant benefits in all of these areas of operation.

## Overall System Design

The 700 Series system uses state-of-the-art techniques to offer superb audio quality and formidable security. Audio is sampled at 44.1 kHz using a 24-bit A/D converter in the transmitter. (For perspective, a CD uses the same sample rate, but only 16 bits per sample.) High-entropy encoding, cryptographically secure encryption, efficient modulation/demodulation, decryption and decoding all take place in the digital domain, using highly optimized proprietary techniques. If digital audio output is desired, there is no need to convert back to analog at all; otherwise, the first and only conversion back to analog occurs at the receiver's output.

In the transmitter, the audio first passes through a DSP-controlled, dual-envelope analog limiter to prevent distortion from occurring on high level peaks. The audio is then digitized and fed to a DSP. The DSP uses a proprietary audio encoding scheme to lower the bit rate and provide the high entropy required for secure encryption. The bit stream is then encrypted, apportioned into packets, and sent over the air using a proprietary digital modulation technique.

In the receiver, the digital baseband signal is demodulated to recover the original bit clock and data stream.

The DSP separates out the packet headers and decrypts the audio data. The audio data is then decoded to recover the original audio signal present in the transmitter.

## UDR700 Encrypted Digital Receiver

### Rota-Versity™ Reception

The UDR700 receiver uses a proprietary technique to implement a unique and very effective type of diversity reception called Rota-Versity™.

Rota-versity is a microprocessor controlled antenna phase matching technique. The UDR700 uses a four way phase shifter to combine the power of the two antennas in any of four phase angles, 90 degrees apart. Hundreds of times per second, all of the four phase angles are tried. The angle offering the best reception is always used for the audio data. The result is that the diversity system “tracks” the phase shifts between the two antennas, keeping phase cancellation loss under 1 dB at all times. Multi-path dropouts are minimized and operating range is maximized by using both antennas, in phase, at all times.

### RF Section

The RF section of the UDR700 is a traditional dual-conversion superheterodyne receiver. Once the antenna power is combined, the RF signal is passed through dual tracking filters. These 7 MHz bandpass filters are centered on the operating frequency as it is tuned through the 25.6 MHz frequency block for excellent selectivity and interference rejection. The first tracking filter is followed by a GaAs FET attenuator that applies from 2 to 32 dB of attenuation to provide very high overload protection. The amount of attenuation is controlled by the RSSI (Received Signal Strength Indicator) feedback from the second IF.

## UDR700 Block Diagram

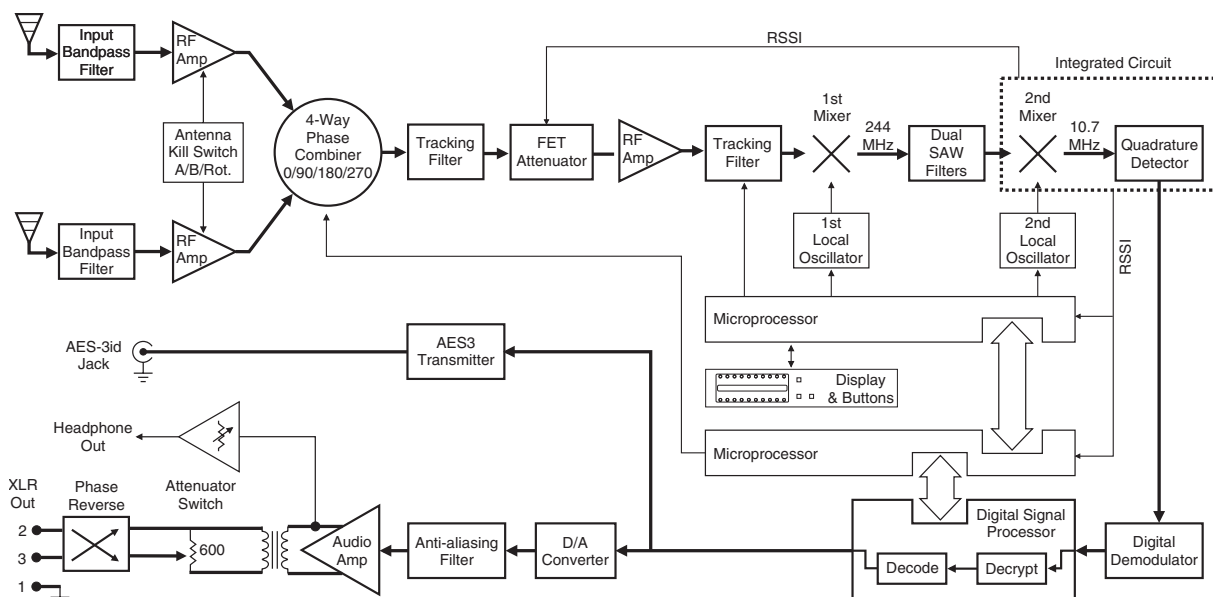

The 244 MHz from the first IF is reduced to the second IF of 10.7 MHz, and is then fed to the Quadrature Detector. The first mixer is a GaAs MMIC device with a rated IP3 (third order intercept) of +24 dBm to minimize undesired IM products. Because the signal is digital, thermal drift in the detector has little effect on the signal's content, unlike an analog receiver.

### Digital Demodulator

The digital demodulator consists of a PLL clock recovery circuit and a bit slicer. The recovered bit clock and data stream are fed to the DSP. In addition, the recovered bit clock is used to derive the timings for the receiver's digital audio circuits, so the receiver audio is synchronous with the transmitter audio, sample for sample.

### Digital Signal Processing

The DSP uses the packet headers as a timing reference to recover the digital audio data. The data is then decrypted and decoded to recover the original digitized audio samples. Additionally, the packet headers also contain transmitter battery status information, which is extracted by the DSP.

### Audio Output

The digital audio samples are sent to the AES-3id transmitter for digital audio output, and to the D/A converter for conversion to analog. The converter output is filtered and amplified, and then fed to a transformer, attenuator and XLR jack. The analog output is also sent to a separate headphone amplifier on the UCR700 front panel for monitoring purposes. The signal at the headphone output is taken just ahead of the output transformer, so it provides the same audio quality as the XLR output and can also be used as a second output or recorder feed.

The main audio output amplifier is set for maximum gain. This output passes through a passive attenuator and phase switch on its way to the rear panel Audio Output XLR jack. The passive attenuator reduces the audio level in calibrated 5 dB steps, ensuring the signal-to-noise ratio of the receiver remains the same at all output levels selected by the rear panel control.

### Encrypted Digital Transmitters

Two encrypted digital transmitters are offered, a belt pack unit and a hand held unit. Although their physical packages differ, internally, they are essentially the same. The major difference is the microphone input jack in the UM700 and the VariMic™ used in the UT700 hand held transmitter.

The microphone input jack used in the UM700 is configured so that virtually every lavalier, hand-held or shotgun mic can be used, regardless of whether they use positive or negative bias. (See UM700 Controls and Functions and 5-Pin Input Jack Wiring.)

The UT700 uses a built in microphone element. (See UT700 Microphone Element.)

### DSP-Controlled Dual Envelope Analog Limiter

In order to make the best use of the high quality A/D converter, microphone audio is limited in the analog domain first, before being sampled. The DSP controls this process, but because the limiting is done in the analog domain, levels near the converter's maximum may be used without fear of clipping. (The limiter has a range of more than 30 dB for excellent overload protection.)

The limiter has a fast attack, but different release characteristics, depending on the nature of the signal that drove the input into limiting. Brief transients result in a fast decay, to avoid "pumping" effects, while sustained loud signals result in a slower decay, to keep distortion to a minimum. The result is a transparent-sounding limiter with excellent low distortion characteristics.

## UM700 Block Diagram

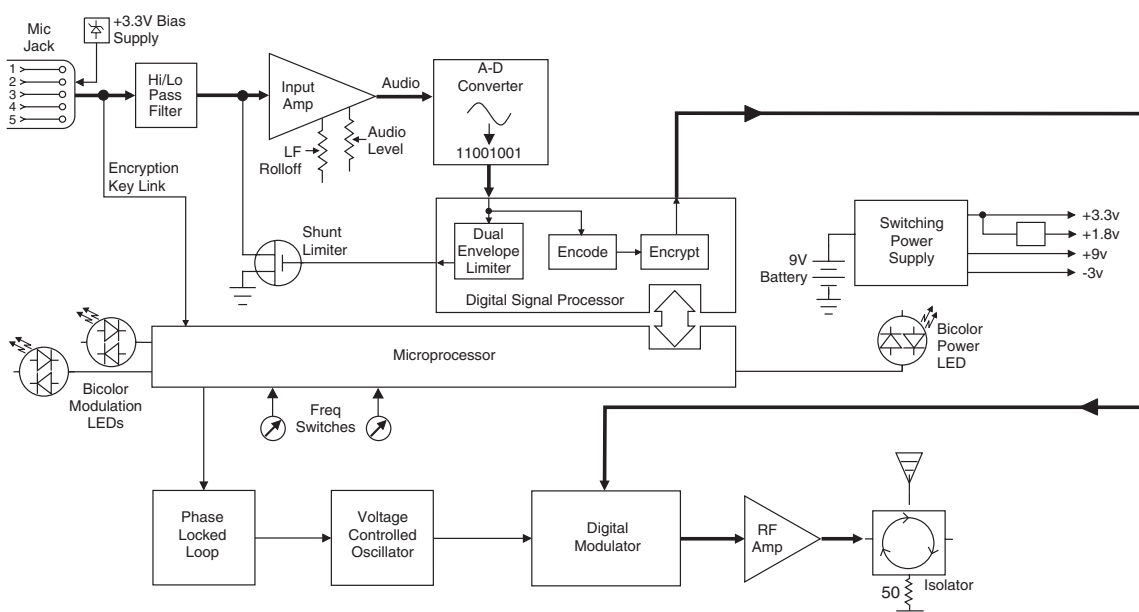

## Digital Signal Processing and Modulation

The preamplified and limited audio signal is converted to digital using a 24-bit A/D converter and fed to the DSP. Within the DSP, the audio is encoded to reduce the bit rate and increase entropy in the data stream prior to encryption. The data stream is then encrypted and apportioned into packets, delimited by packet headers. The complete bit stream is modulated onto the carrier using a modified pi/4 DQPSK (differential quadrature phase shift keying) method. This modulation method makes efficient use of the RF spectrum and is easy to demodulate reliably.

## Transmitter RF Output Section

Intermodulation (IM) is a problem that occurs in the final amplifier stages of conventional transmitters when the transmitters are within a few feet of each other. This can create serious problems in multichannel wireless systems when an IM signal falls in the same range as the carriers, IF frequencies, local oscillator or image frequencies of the systems being operated. The UM700 and UT700 eliminate this problem by passing the modulated radio signal through a circular isolator before it enters the antenna. The circular isolator functions like a “one-way check valve,” allowing the RF signal to pass through to the antenna, but not allowing spurious RF to pass back into the transmitter amplifier stage. This provides excellent stability and eliminates IM in the output stage of the transmitter.

## Long Battery Life

The use of highly efficient circuits and switching power supplies throughout the design allow over 4 hours of operation using a single 9 volt alkaline battery. (A 9 V lithium battery will provide over 7.5 hours of operation.) The battery compartment is a unique mechanical design which automatically adjusts to fit any brand of 9 volt battery, and the battery contacts are spring loaded to prevent “rattle” as the unit is handled.

## Frequency Agility

700 Series wireless systems are currently available in four different “blocks” of 256 frequencies each, from 562.200 to 665.500 MHz.

*Note: Frequencies between 608.000 MHz to 614.000 MHz are reserved and not available for commercial use.*

Each of these blocks is preset at the factory and provides 256 selectable frequencies in 100 kHz steps over a 25.6 MHz bandwidth. This wide variety of selectable frequencies alleviates carrier interference problems in mobile or traveling applications. Two 16-position rotary switches are used to select the frequency.

The transmitter section uses a synthesized, frequency selectable main oscillator. The frequency is extremely stable over a wide temperature range and over time.

## Antenna

At UHF, where wavelengths and antennas are shorter than at VHF, a resonant length wire is preferred over using the microphone cable as the antenna. The antenna on the UM700 is a flexible 1/4 wavelength insulated galvanized steel cable, detachable via an SMA connector. The impedance of this connector is 50 Ohms.

The UT700 has a dipole antenna incorporated into the circuit board.

## UT700 Microphone Element

The UT700 includes the Lectrosonics VariMic™ mic element. The VariMic™ is a cardioid condenser (back electret) microphone that is adapted for the unique circumstances of wireless microphones. It offers excellent dynamic range while minimizing handling noise and low frequency noise (rumble or wind).

In the VariMic™, an unusual pumped source FET circuit increases the usable dynamic range 12 dB and greatly reduces distortion, just as if the FET were being

## UT700 Block Diagram

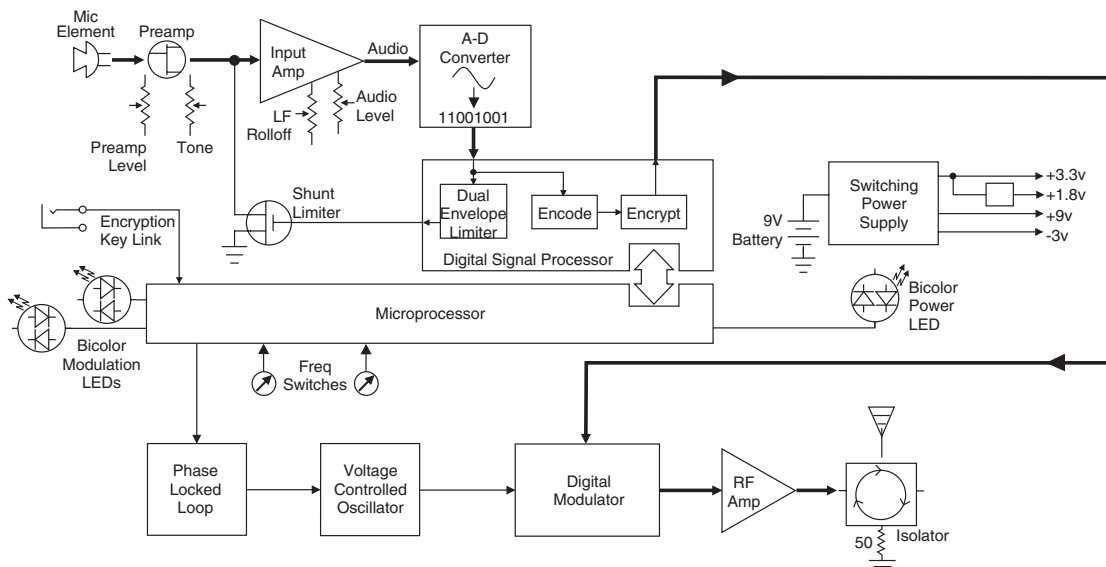

supplied with 48 Volts. A unique 16-position sensitivity control at the element itself can also adjust the sensitivity over a 15 dB range. This is in addition to the normal gain control in the wireless microphone. The result is the widest dynamic range of any condenser mic in a wireless microphone.

The VariMic™ has a three-point damped rubber suspension to reduce high frequency handling noise and a generous sized windscreen to keep wind noise and breath pops away from the microphone.

## Comparing Diversity Reception and Rota-Versity™

The UDR700's new approach to diversity reception is a vast improvement over traditional designs. Traditional analog diversity reception designs employed techniques ranging from simple antenna and audio signal switching using one or two receivers, to dual-receiver ratio combining systems. In the digital realm, even more advanced techniques are possible to analyze and correct antenna phase.

A popular phrase, "true diversity," arose in defense of dual-receiver audio switching diversity designs versus very low cost receivers that simply had two antennas mounted on a single unit. Diversity reception can be implemented by mixing or selecting the audio from two separate receivers, or by various antenna combining techniques ahead of the receiver. In reality, all receiver designs can aptly be called "true diversity" if they make use of two or more antennas that are receiving diverse (uncorrelated) signals.

Two diversity designs found in use today include Audio Switching Diversity and Ratio Diversity. Both offer some improvement in audio reception, but with a significant increase in equipment costs because of the need for two receivers. SmartDiversity™ from Lectrosonics is different.

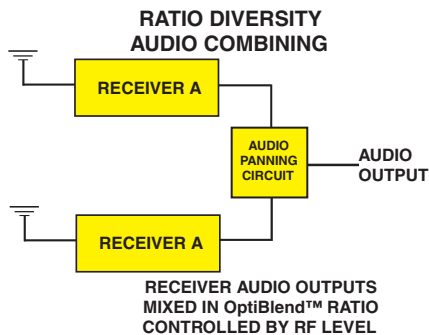
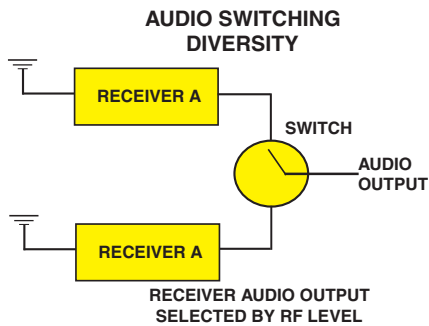

### SmartDiversity™

SmartDiversity™ is a microprocessor controlled technique that automatically analyzes audio content and RF levels to determine optimum timing for the switching activity. Active analog antenna phase switching techniques use both antennas at the same time, with 180 degree phase switching to help keep the received signals in phase and minimize dropouts. When the overall RF signal strength quickly drops, the phase of one antenna is switched 180 degrees. If the switch increases the RF level, it will remain latched in that position until the RF level quickly drops again. Both antennas are used at the same time, so overall operating range is also improved.

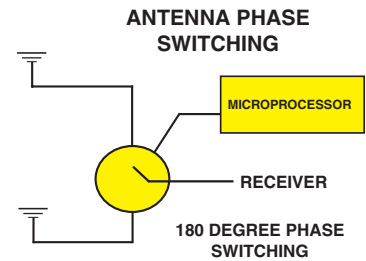

### Rota-Versity™

Rota-Versity™ is only possible in the digital realm. Rota-Versity™ uses a four-way phase shifter to combine the output of two antennas in any of four phase angles, each 90 degrees apart, regardless of RF levels. Hundreds of times per second, all of the phase angles are explored, with the angle offering the best reception used for the audio data. The result is the diversity system "tracks" the phase shift between the two antennas to ensure that they always add to one another (they are always less than 90 degrees out of phase). Multi-path dropouts are minimized and operating range is maximized by using both antennas simultaneously. Because it times phase switches to happen only during digital packet headers where no audio is being conveyed, Rota-Versity™ is also transparent and cost effective.

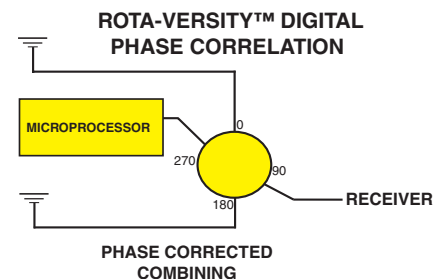



# The 700 Series Encryption System

To guard against eavesdropping, the encryption in the 700 Series digital wireless system makes use of several processes and a unique key setup procedure to provide a high level of entropy and thus maximum security. A 128-bit key is used to create a formidable barrier against brute force attacks attempting to break the encryption code. The result is 340 trillion, trillion, trillion possible key combinations.

The audio signal entering the transmitter first passes through a DSP controlled, dual-envelope limiter that cleanly limit signal peaks up to 30 dB above full modulation. The signal is then converted to 24-bit digital audio, with sampling at 44.1 kHz. The resulting bit stream is then digitally compressed to meet the bandwidth requirements for the radio output, encrypted and then transmitted over the air.

The encryption key setup procedure involves a cable connection between the transmitter and receiver. Once connected, the receiver maybe placed into the key generation mode and the operator is prompted to make several button pushes on the front panel of the receiver. These button pushes capture the instantaneous value of a fast, free running, 16-bit timer. The captured values are combined to create the eight, 16-bit segments of the 128-bit encryption key.

With the exception of Security Level 3, any number of transmitters can be connected during a single setup procedure to share a common encryption key. Regardless of which Security Level is selected, only one receiver can share the key with the transmitter(s). This prevents the use of a second receiver to eavesdrop on the transmitted signal.

The 700 System offers three levels of security, trading off ease of use for immunity to attack.

## Level 1

Security Level 1 offers the most intuitive operation. Once the key has been set, the equipment may be operated exactly the same as a traditional analog system. The transmitter and receiver may be powered on in any sequence, and the transmitter may move in and out of range without consequence (except normal squelching). Security in this mode is excellent, but the scrambling sequence repeats approximately every 20,000 bits, theoretically exposing the user to differential attacks. Due to its ease of use and quite effective security, Level 1 is the default security level.

## Level 2

Security Level 2 offers much greater encryption strength, at the cost of slightly less intuitive operation. In Level 2, the scrambling sequence never repeats (i.e. the PRNG is free-running), so the receiver must be on and ready to receive when the transmitter is first switched on. Some signal loss is tolerated but if the transmitter should wander out of range for more than ten seconds, it will be necessary to switch it off and on again to restart the sequence, resynchronizing with the receiver. Security in this mode is a great deal stronger than Level 1, since the scrambling sequence never repeats. Only if the sequence is deliberately reused (i.e. by cycling transmitter power after prolonged signal loss, or by reusing the same key session after session) is a differential attack possible even in theory.

## Level 3

Security Level 3 offers the strongest encryption of all, again at the cost of some convenience. Level 3 is much like Level 2, except that the equipment itself enforces a policy that *no portion of any scrambling sequence shall ever be used more than once*. This is a fundamental tenet of cryptography: key reuse leads to vulnerability. Thus, Level 3 security is about as close to the holy grail of the one-time pad as any wireless vendor is likely to offer at a reasonable price. Operation is a little different in Level 3:

1. The transmitter will not send any audio until a new key is transferred from the receiver.
2. Only one transmitter may receive each key.
3. If the transmitter is out of range of the receiver for more than ten seconds, it will be necessary to generate a new key in order to continue using the system.

All three levels offer strong encryption, so each user may make a policy decision based on an assessment of risk. Those requiring ease of use may relax, knowing that eavesdropping is extremely difficult even in Level 1. Many users may find Level 2 to be just as convenient, allowing them to use greater encryption strength. Those users willing to follow stricter security procedures can use Level 3, the strongest encryption available today from a wireless microphone.

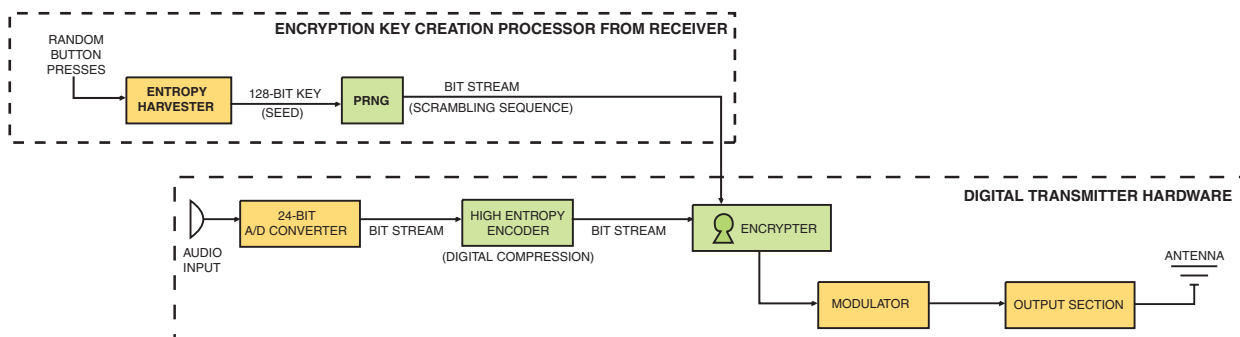



# UDR700 Controls and Functions

## UDR700 Front Panel

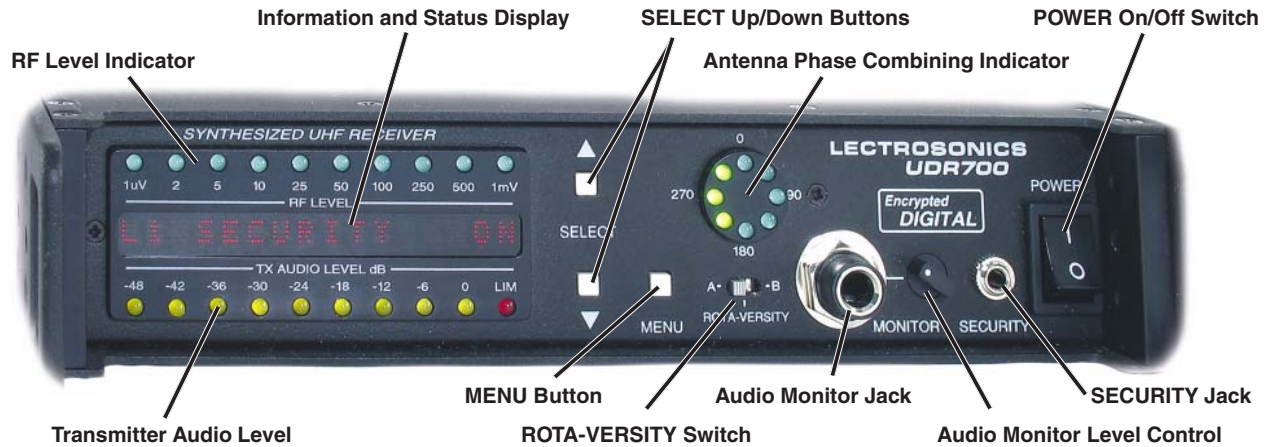

### RF Level Indicator

A 10-segment LED strip indicates the level of the incoming RF signal. The strip is calibrated to provide accurate indications from 1  $\mu$ V to 1 mV. The LEDs are highly visible from a distance.

*Note: A digital wireless receiver behaves differently than an analog receiver during weak RF signal conditions. The audio signal to noise ratio of an analog receiver will gradually deteriorate as the RF signal level drops, and the receiver will continue to produce audio (accompanied by some noise) even at very low RF levels. The signal to noise ratio of a digital receiver remains largely unchanged as the RF signal level drops, until suddenly, over a range of just a few dB, the signal abruptly degrades and then is muted altogether.*

The RF Level Indicator can accurately display signals as low as 1  $\mu$ V to permit checking for interfering signals just below the squelch threshold of the receiver. With the transmitter turned off, the LEDs will indicate the presence of interference.

### Transmitter Audio Level

The 10-segment Transmitter Audio Level indicator strip displays the modulation (audio level) of the incoming signal. The strip is calibrated in 6 dB steps over an expanded scale (54 dB) providing an extremely accurate visual "picture" of the signal dynamics.

### Information and Status Display

A 16-segment Information and Status Display provides information about the security level, selected frequency, or tuning group, transmitter Frequency Select Switch setting, TV channel, transmitter battery level and system locked/unlocked status.

### Menu Button

The MENU button steps the Information and Status Display through six different displays used for setup and operation. (See Information and Status Display Menus and Functions and Installation and Operating Instructions.)

### Select Up/Down Buttons

The SELECT Up/Down buttons are used to select various options within each display selection and for setting the operating frequency of the receiver.

### Rota-Versity™ Switch

The Rota-Versity™ switch is a three-position switch used to either enable diversity operation, or to temporarily disable diversity operation (by selecting antenna A or antenna B) for diagnostic purposes.

### Antenna Phase Combining Indicator

Indicates the phase relationship between antenna A and right for antenna B. Also provides a visual warning if the Rota-Versity switch is not in the normal (centered) position, or if one of the antennas is malfunctioning.

### Power Switch

The Power switch applies AC or External DC power to the unit. This switch, in conjunction with the MENU button, can also be used to lock, or unlock the front panel buttons (see Disabling Front Panel Buttons), and in conjunction with the SELECT Down button, can be used to set the Security Level. (See Installation and Operating Instructions, Setting the Security Level.)

### Security Jack

The Security Jack is a 3.5 mm mono connector used to set the security level of the associated transmitter(s). (See Installation and Operation Instructions, Setting the Security Level.)

### Audio Monitor Level

The Audio Monitor Level controls the amplitude of the audio output from the Audio Monitor Jack.

### Audio Monitor Jack

The 1/4-inch, stereo, Audio Monitor Jack will drive a wide variety of different types of headphones and can also be used as a second high quality audio output to drive recorders or other external audio devices.

## UDR700 Rear Panel

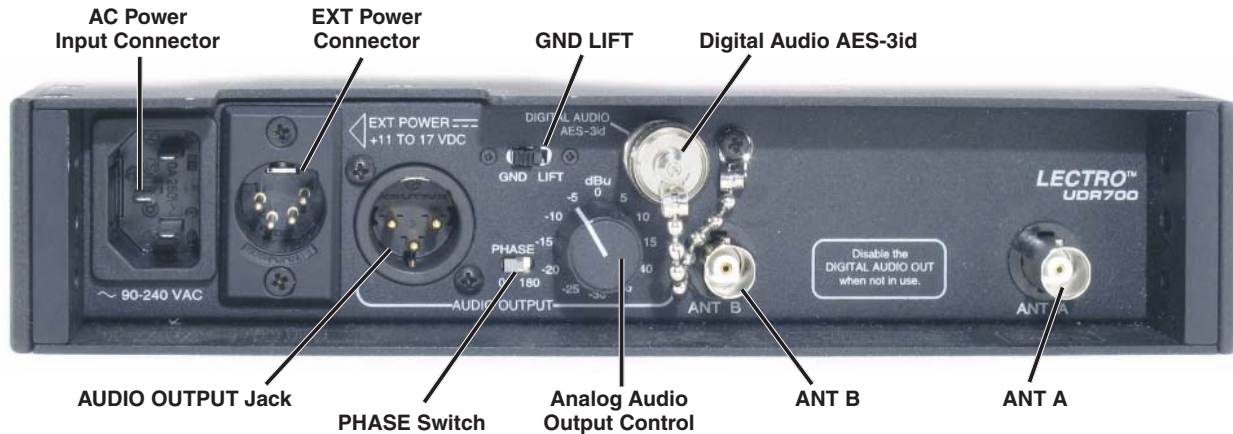

### AC Power Supply

The UDR700 has a universal switching power supply which operates on AC voltages ranging from 95 to 240 Volts, 50 or 60 Hz. Since the power supply is self protected against line transients, short circuits, and over current conditions, there is no external fuse.

### EXT Power Connector

This 4-pin XLR jack is also provided for connecting to an external power source (+11 to +17 VDC) if desired. The EXT POWER Connector accepts a standard 4-pin female XLR connector wire so that Pin 4 is positive and Pin 1 is ground.

### Analog Audio Output Control

A calibrated control on the rear panel adjusts the output level in 5 dB increments, calibrated in dBu. This control adjusts the absolute output level at the rear panel XLR connector when the transmitter is fully modulated (maximum audio level). The Analog Audio Output Control is located after the output transformer allowing the signal to noise ratio to remain constant regardless of the control's setting.

### GND/LIFT Switch

The GND/LIFT switch either applies or removes chassis ground from Pin 1 of the AUDIO OUTPUT jack. Lifting the chassis ground is useful when AC hum is generated by a ground loop.

*Note: Ground loops can occur when the analog audio output is connected to remote equipment powered from a different AC main supply.*

### Phase 0/180

The PHASE 0/180 switch reverses the polarity of the analog audio output signal.

### Digital Audio Output - AES-3id

A BNC connector providing a digital audio output signal conforming to the AES-3id standard.

### Antenna Jacks

These are standard 50 Ohm BNC terminals for the RF input to the receiver. Both antennas are required for diversity mode (normal) operation.

## UDR700 Information and Status Display Menus and Functions

### Power Up Sequence

When the UDR700 is powered up, the Information and Status Display will display three messages in sequence followed by one of the three tuning menus (Main Tuning Menu, TV Tuning Menu or Group Tuning Menu).

Buttons Enabled/Disabled

Security Level

Firmware Version/Decoder Firmware Version

B U T T O N S      E N A B L E D

S E C U R I T Y    L E V E L    1

U D R 7 0 0      V 3 . 0 / 3 . 0

The tuning menu displayed is the last tuning menu displayed prior to the last time the UDR700 was turned off.

### Enabling and Disabling the Buttons

The front panel control buttons (MENU, SELECT Up/Down) can be disabled (locked) to prevent accidental operational changes during use.

When the UDR700 is turned on, the first message displayed on the Information and Status Display will be either **BUTTONS ENABLED** or **BUTTONS DISABLED**.

If buttons are disabled, pressing any button causes the message **BUTTONS DISABLED** to be displayed briefly and no action will be taken.

To toggle between **BUTTONS ENABLED** and **BUTTONS DISABLED**, press and hold the **SELECT Up** button while setting the **POWER** switch to **On**.

## Menu Interface

The menu interface consists of six linked menus:

- Main Tuning
- TV Tuning
- Group Tuning
- AES Output
- Security
- Key Generation

The **MENU** Button is used to cycle through the menus. The menus are:

## Main Tuning Menu

The Main Tuning menu is normally the first screen that appears on the Information and Status Display after the power up sequence is complete. This screen shows the frequency (in MHz) that the UDR700 is tuned to, the transmitter battery voltage (if actively receiving this information from the transmitter) and the Frequency Select Switch settings for the transmitter.

6 6 8 . 1 0 0 8 . 7 V 1 9

If the transmitter battery is low, the voltage display will blink. If the transmitter battery is very low, a “Battery Low” warning message will flash periodically, regardless of what menu is currently being displayed.

The UDR700 comes preloaded with three groups of seven selected intermod-free frequencies. In the Main Tuning menu, the **SELECT Up** and **Down** buttons can be used to navigate among the seven frequencies in the current group. (See **Group Tuning Menu**.)

You can also tune the receiver across the 25.5 MHz block in 100 kHz increments by pressing the **SELECT Up** or **Down** button while pressing and holding the **MENU** button. Holding either **SELECT** button down activates an autorepeat function for faster tuning.

If pressing any button results in “**BUTTONS DISABLED**” being displayed, the front panel buttons have been disabled. (See **ENABLING AND DISABLING THE BUTTONS**.)

## TV Tuning Menu

The TV Tuning menu is just like the Main Tuning menu, except that the applicable UHF TV channel number is shown in the center of the display in place of the transmitter battery voltage. This makes it easier to avoid occupied UHF TV channels in the geographical area of operation.

6 6 8 . 1 0 0 T V 4 7 1 9

## Group Tuning Menu

The Group Tuning menu displays the current group (the three groups are designated A, B, and C) and the selected frequency within that group. The Transmitter Frequency Select Switch settings are shown at right, as on the other tuning menus.

G R P A C H A N 1 ▲ ▼ 2 0

In the Group Tuning menu, the **SELECT Up** and **Down** buttons navigate among the seven frequencies in the current group. To choose a different group, press either **SELECT Up** or **Down** while holding down the **MENU** button.

*Note: If one of the tuning menus is active when the receiver is powered down, the receiver will return to that same menu following the three boot messages the next time it is turned on.*

## AES Output Menu

The AES Output menu allows toggling the **DIGITAL AUDIO OUTPUT** (AES-3id jack at the receiver’s back panel) on or off. Use the **SELECT Up** and **Down** buttons to change the setting.

**Caution: To minimize the chance that the digital audio output signal will radiate unwanted RF energy, this function should be turned off unless the digital audio output is in use.**

## Security Menu

The Security menu displays the current security level. (See **The 700 Series Encryption System**.)

L 1 S E C U R I T Y O N

This menu also allows decryption in the receiver to be temporarily turned off. Use the **SELECT Up** and **Down** buttons to toggle between decryption on and off. If the UDR700 is turned off with decryption disabled, decryption will automatically be enabled when the unit is powered up again.

*Note: The only reason to turn decryption off is to hear what the received audio sounds like without the right decryption key. 700 Series transmitters are incapable of transmitting an unencrypted signal.*

## Key Generation Menu

The Key Generation menu is the entry to the security key generation process.

M A K E N E W K E Y ? ▲

Press **SELECT Up** to begin the new key generation process. (See **SETTING THE ENCRYPTION KEY**.)

# UM700 Controls and Functions

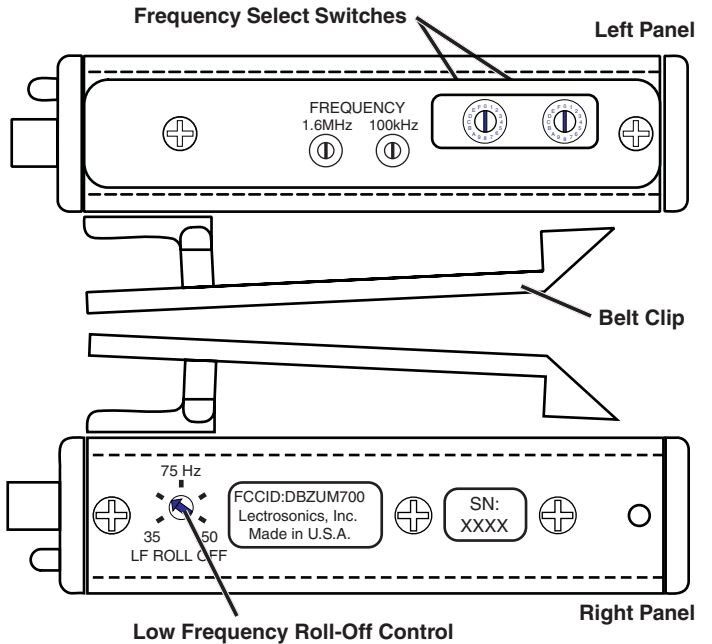
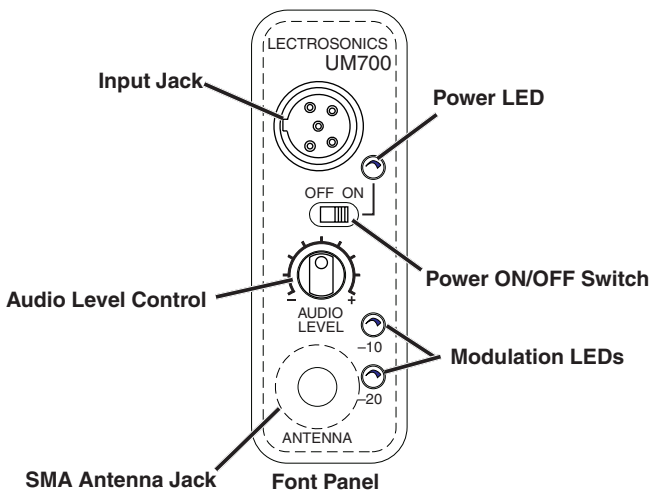

## Input Jack

The input jack on the UM700 is a Switchcraft TA5M connector that accommodates virtually every lavalier, hand-held or shotgun microphone available, regardless of whether they use positive or negative bias. Use a Switchcraft TA5F connector on the microphone cable or input adapter cord. The input circuits will also cleanly handle line level signals up to 300 mV before limiting (higher with special wiring). (See 5-Pin Input Jack Wiring, Line Level Signals (UM700).)

## Power On/Off Switch

The Power On/Off Switch turns the battery power on and off. Digital muting prevents “thumps” or transients from occurring in the event that the switch is turned off or on abruptly.

## Power LED

The Power LED glows green when the battery is good and the ON/OFF switch is set to ON. The LED glows yellow/orange as the battery voltage drops and finally glows red when there are about 30 minutes of operation left (with an alkaline battery). The lamp will blink red when there are only a few minutes of battery life left.

**Caution: A NiMH battery will give little or no warning when it is depleted. If you wish to use NiMH batteries in the UM700, we recommend trying fully charged batteries in the unit, noting the length of time that the batteries will run the unit and in the future use somewhat less than that time to determine when the battery needs to be replaced.**

A weak battery will sometimes cause the Power LED to glow green immediately after the unit is powered up, but will soon discharge to the point where the LED will go red, flicker red or shut off completely (much like a flashlight with “dead” batteries). If the lamp fails to light, the battery should be replaced.

## Frequency Select Switches

These two 16-position rotary switches (located under a sliding door on the transmitter’s left side) adjust the center frequency of the carrier. The 1.6 MHz switch is the coarse adjustment and the 100 kHz switch is the fine adjustment.

## Audio Level Control

The front panel Audio Level Control is used to adjust the incoming audio input level for proper modulation.

## Modulation LEDs

The Modulation LEDs provide a visual indication of the input audio signal level from the microphone and feedback as the transmitter is turned about the selected security level.

These two bicolor LEDs can glow either red or green to indicate modulation levels.

Signal Level	-20 LED	-10 LED
Less than -20 dB	Off	Off
-20 dB to -10 dB	Green	Off
-10 dB to +0 dB	Green	Green
+0 dB to +10 dB	Red	Green
Greater than +10 db	Red	Red

When the transmitter is first switched on, the modulation LEDs blink a code that indicates the current security level:

- Level 1 Security    one blink
- Level 2 Security    two blinks
- Level 3 Security    three blinks

The insulated flexible galvanized steel cable antenna supplied with the transmitter is cut to 1/4 wavelength of the center of the frequency block (the frequency range) of the transmitter. It is removable via an SMA connector. The SMA connector is a 50 Ohm RF port which can also be connected directly to test equipment. Replacement antennas are available in pre-cut lengths for specific frequency blocks, or as a kit with instructions to cut the antenna for any frequency block. Replacement antenna is part AMM(xx) where "xx" indicates the frequency block, i.e.. AMM27 for block 27. (See Accessories Master Catalog, or visit [www.lectrosonics.com](http://www.lectrosonics.com).)

### Adjustable Low Frequency Roll-Off Control

An 18 dB per octave Low Frequency Roll-off Control is provided in the audio section, with the -3 dB point adjustable from 35 Hz to 150 Hz. The actual roll-off frequency will vary according to the low frequency response of the mic capsule being used.



The low frequency roll-off control is used to reduce the undesirable effects of very low frequency audio, such as those produced by air conditioning systems, automobile traffic and other sources. Excessive low frequency content in the audio input can cause overload of the program audio in recording applications. In sound reinforcement systems, excessive low frequency content can cause excessive power amplifier drain or even damage to loudspeaker systems. A common example is wind blowing across a microphone, causing very high levels of low frequency audio (wind noise). By rotating the roll-off control clockwise, the hinge point of the roll-off is increased to reduce the level of low frequencies. In low noise situations, such as a motion picture production set indoors where environmental noise is minimal, the control can be rotated counter-clockwise to permit low frequency audio to be captured.

### The Belt Clip

The belt clip may be removed for special applications by removing the Belt Clip Attachment Screw.

**WARNING: USE ONLY THE SCREW THAT IS SUPPLIED.**

The circuitry is tightly packed into this unit. A longer screw will permanently damage the transmitter! Use only Lectrosonics PN:28528 which is a Phillips head, 4-40 x 3/16", FL100 screw.

Belt Clip Attachment Screw location

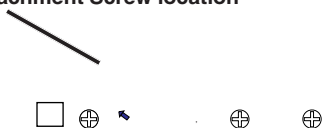

### UM700 Battery Installation

The transmitter is powered by a standard alkaline or lithium 9 volt battery. Use alkaline or lithium batteries for longest life. Standard zinc-carbon batteries marked "heavy-duty" or "long-lasting" are not adequate. Ni-cad or NiMH rechargeable batteries provide 1.5 hours of operation, or less, and will run down quite abruptly. Unless it is cold, alkaline batteries provide over 4.0 hours of operation. Lithium batteries can be used to provide up to 7.5 hours. Care should be taken not to leave a fully discharged lithium battery in the transmitter, as swelling of the battery can make it difficult to remove from the compartment. The battery status circuitry is designed for the voltage drop over the life of alkaline batteries.

To open the battery compartment, press outward on the cover door in the direction of the arrow as shown in the drawing. Only firm, sliding pressure is needed to open and close the battery door. Swing the door open and take note of the polarity marked inside showing the location of the positive (+) and negative (-) terminals. You can see the large and small contact holes inside the battery compartment with the door open.

Insert the battery correctly and close the cover by pressing the door closed and across, reversing the opening procedure illustrated above. If the battery is inserted incorrectly, the door will not close. Do not force the door closed.

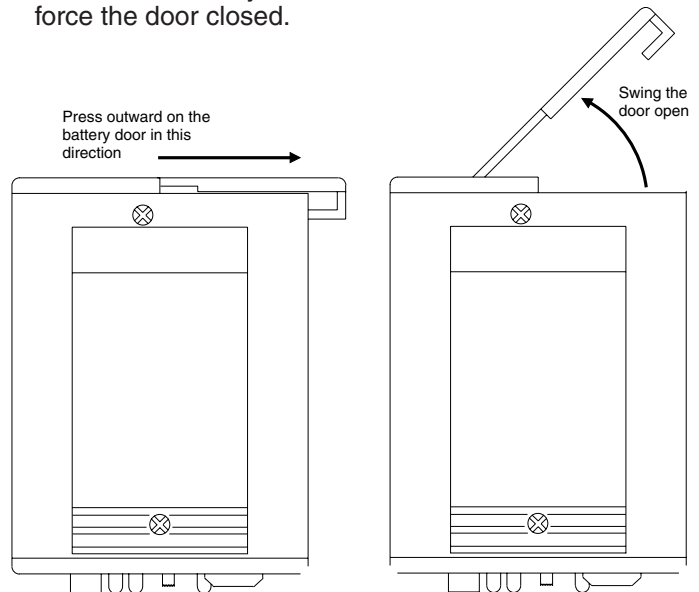

# UT700 Controls and Functions

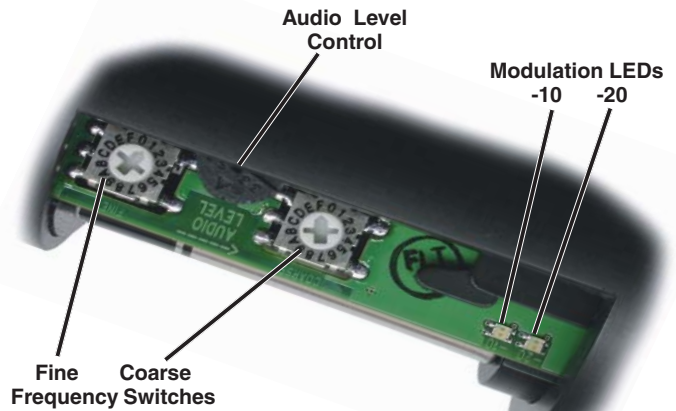
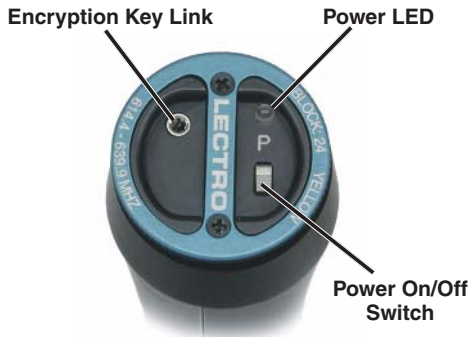

## Power On/Off Switch

The Power On/Off slide switch is located on the outside bottom of the unit and controls power to the transmitter.

## Power LED

The Power LED glows green when the battery is good and the On/Off switch is set to On. The LED glows red as the battery voltage drops and blinks when there is about 30 minutes of operation left with the recommended alkaline battery.

*Note: A weak battery will sometimes cause the POWER LED to glow green immediately after being put in the unit, but will soon discharge to the point where the LED will either glow red or the transmitter shuts down. If the lamp fails to light, the battery should be replaced.*

*Caution: A NiMH battery will give little or no warning when it is depleted. If you wish to use NiMH batteries in the unit, we recommend trying fully charged batteries, noting the length of time that the batteries will run the unit and in the future use somewhat less than that time to determine when the battery needs to be replaced.*

When the unit is first turned on, the Power LED also blinks a code to indicate the current Security Level.

- Level 1 - One blink
- Level 2 - Two blinks
- Level 3 - Three blinks

## Hiding the Power LED

This unit has no provision for disabling the LEDs. The Audio Level LEDs are covered during normal use but the Power LED is exposed. If the light is objectionable, we recommend covering the Power LED with a piece of opaque tape.

## Encryption Key Link

The Encryption Key Link is used to connect the transmitter to the UDR700 Series receiver to set an encryption key.

## Frequency Select Switches

Two 16-position rotary Frequency Select Switches (located in the battery compartment) are used to adjust transmitter's operating frequency. The Coarse switch adjustment adjusts the frequency in 1.6 MHz increments and the Fine switch adjusts in 100 kHz increments.

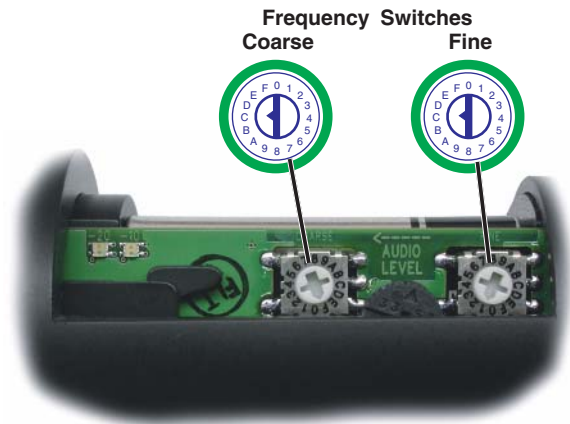



## Modulation LEDs

The Modulation LEDs (located under the Battery Compartment Door) provide a visual indication of the input audio signal level from the microphone. These two bicolor LEDs can glow either red or green to indicate modulation levels.

Signal Level	-20 LED	-10 LED
Less than -20 dB	Off	Off
-20 dB to -10 dB	Green	Off
-10 dB to +0 dB	Green	Green
+0 dB to +10 dB	Red	Green
Greater than +10 db	Red	Red

## Audio Level Control

The Audio Level control is used to set the audio input level (or gain) for the proper modulation. Located under the battery door, this control is rotated while speaking or singing into the microphone to set the modulation level.



## Locked Mode

The UT700 can be placed in a locked mode where neither the Power On/Off Switch nor the Frequency Select Switches have any further effect on operation. This protects the unit from accidental power off or misadjustment after it has been prepared for use.

To enter locked mode, start with the transmitter turned on and toggle the Power On/Off Switch off and on rapidly three times. (Each toggle must be shorter than two seconds and there must never be more than 10 seconds between toggles.)

After the third toggle, the power LED will go out briefly, then blink the current security level in red indicating locked mode.

Locked mode can be cleared by removing the battery.

*Note: Removing the transmitter battery may cause noise in the associated receiver. It is suggested to turn the receiver audio volume off prior to removing the transmitter battery.*

## UT700 Battery Installation

**Caution: The transmitter is designed for a standard alkaline or lithium 9 volt battery. It is important that you use an alkaline or lithium battery for longest life. Standard zinc-carbon batteries marked "heavy-duty" or "long-lasting" are not adequate. Ni-cad rechargeable batteries will only provide 1.5 hours of operation, or less, and will run down quite abruptly.**

Alkaline batteries provide over 3.5 hours of operation under normal conditions. Lithium batteries can provide up to 6.5 hours. Care should be taken not to leave a fully discharged lithium battery in the transmitter, as swelling of the battery can make it difficult to remove from the compartment. The battery status circuitry is designed for the voltage drop over the life of alkaline batteries.

The battery compartment is located in the lower section of the transmitter, *between* the two printed circuit boards.



Note the two differently sized holes in the battery contact pad inside the Battery Compartment.

Insert the battery so that the large hole in the battery contact pad will line up with the large contact on the battery. A spring-loaded plunger in the bottom of the compartment (opposite the contact pad) secures the battery in place.

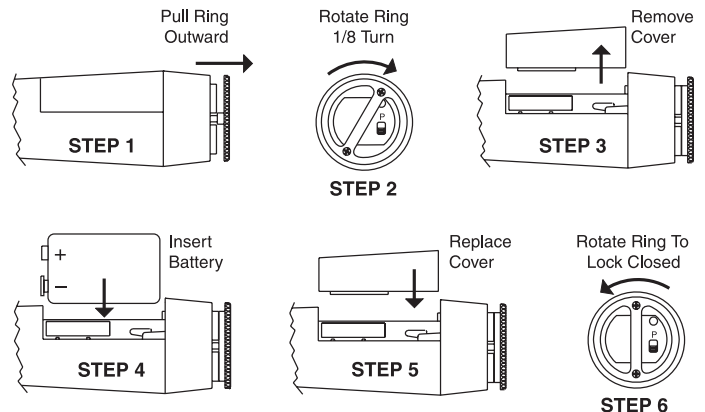

The battery status is indicated by the Power LED located on the UT700 bottom panel. The LED glows green under normal circumstances when there is sufficient power left in the battery. The LED changes to red as the battery voltage drops and starts blinking when only about 30 minutes of operation left with the recommended alkaline battery. Battery status is also displayed on the Information and Status Display on the front panel of the UDR700 receiver.

*Note: It is possible to insert the battery backwards and still be able to close the battery door. No physical damage will occur but the transmitter will not operate in this condition.*



# System Installation and Operating Instructions

## System Setup

- 1) Locate a suitable operating location where the receiver will not be subjected to extreme temperature variations and possible bumps and drops. Try to route all wiring so it will not cross walkways or aisles.
- 2) Connect the power. For AC operation, connect the female end of the power cord to the AC input jack on the rear panel and plug the other end into a suitable electrical outlet.



**AC Power Input Jack**  
90 to 240 VAC, 50-60 Hz

If external DC power is desired, a power cord needs to be fabricated. Use a standard 4-pin female XLR connector for the receiver end and wire it according to the diagram below (Pin 4 is positive and Pin 1 is ground).



**External Power Connector 11-17 VDC**

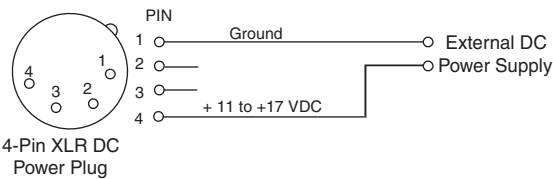

- 3) Connect the antennas. You can use either two remote antennas or two whip antennas with 90-degree connectors to operate the UDR700; however, the operating range may be less with the whip antennas than with the remote antennas. When using remote antennas, for best performance place them at least three feet from each other and as high as possible with a direct line of sight path to the transmitter.



**Antenna Input BNC Connectors**

- 4) Preset the UDR700 controls as follows:  
 Audio Monitor Level Control (front panel) to minimum (CCW)  
 PHASE Switch (rear panel) to "0"  
 Analog Audio Output Control (rear panel) fully CCW (-40 dBu)



**Audio Monitor Level**  
(Counterclockwise)



**PHASE Switch (0)**

**Analog Audio Output Control**

- 5) Connect the Audio Output XLR jack to your mixer input. (Pins 2 and 3 of the XLR jack are HI and LO and can be reversed with the Phase switch, Pin 1 is common.)



**Audio Output XLR jack**

- 6) Set the front panel POWER switch to On and observe the POWER UP SEQUENCE. (See Information and Status Display Menus and Functions.)

**Warning:** Do not turn on the associated transmitter(s).



POWER Switch

- 7) When the Main Tuning Menu appears observe the RF Level Indicator LEDs. (If the Main Tuning Menu is not displayed, press and release the MENU button to step through the menu selections until it is displayed.) If any of the RF Level Indicator LEDs glow or blink, use the SELECT Up or Down button to locate a clear channel (no RF activity) from one of the current factory preset frequency group. If a clear channel is not available using one of the factory preset frequencies, press and hold the MENU button, then press the SELECT Up or Down button to tune across the entire 25.5 MHz frequency block (in 100 kHz steps) to locate one. (See Information and Status Display Menus and Functions, Main Tuning Menu and Group Tuning Menu)

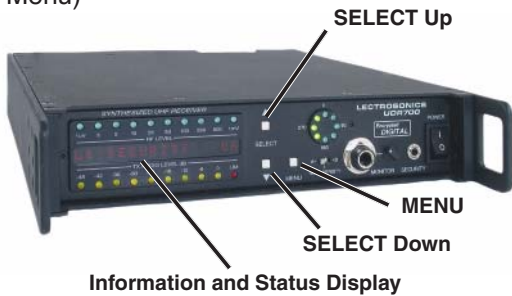

Information and Status Display

- 8) If necessary, install a fresh battery in the transmitter. (See UM700 Battery Installation and UT700 Battery Installation.) Set the Frequency Select Switches on the associated transmitter to match those identified in the receiver's Main or Group Tuning Menus (the two rightmost characters on the Information and Status Display).

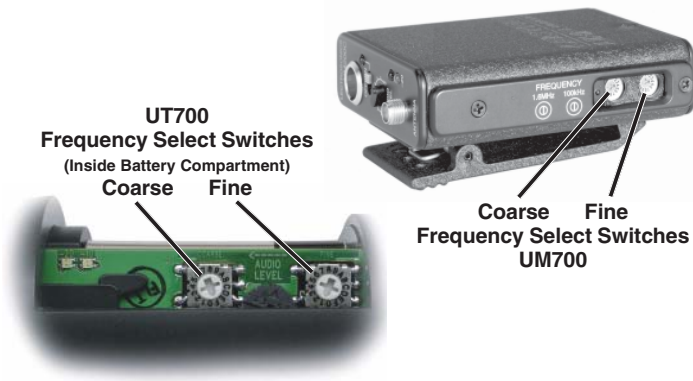

- 9) Determine the security level required. (See The 700 Series Encryption System.)
- 10) Turn the UDR700 Off, then press and hold the SELECT Down button while turning the UDR700 back on. The display will show the current security level. The default is Level 1.
- 11) Use the SELECT Up or Down buttons to choose a new security level, then press the MENU button to finalize the security level selection process. The Information and Status Display displays a message indicating the level of security (Level 1, 2 or 3).

**Note:** Changing security levels requires that a new key be sent to the transmitter before the system will operate. (See Changing Security Level and Setting or Resetting Encryption Key.)

**Warning:** In Security Level 3, both the transmitter and receiver must be turned on and set to the same operating frequency prior to setting the Encryption Key.

- 12) Press the MENU button to enter the Key Generation Menu. "MAKE NEW KEY?" will be displayed in the Information and Status Display with an "Up" arrow to the message's right. (See Information and Status Display, Menus and Functions, Key Generation Menu.)
- 13) Press the SELECT Up button and follow the directions on the Information and Status Display. Eventually the prompt "NEW KEY TO TX ^" is displayed.
- 15) Connect the appropriate KEY CABLE Encryption Cable between the transmitter and the UDR700 and turn on the transmitter.

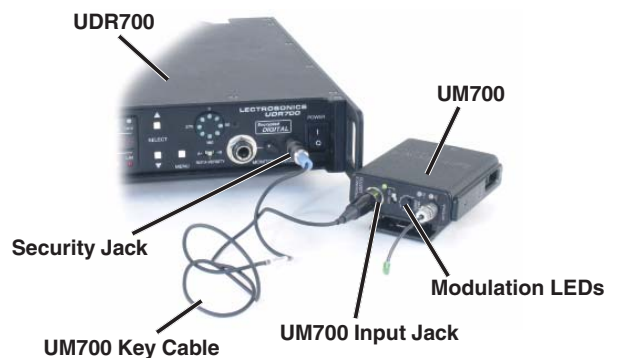
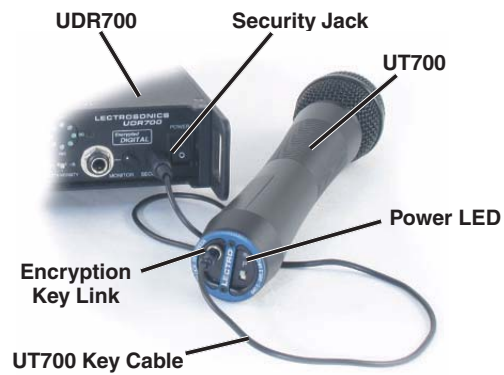

Note: Each transmitter uses a different Encryption Cable. (See Encryption Key Cables.)

- 16) Press the SELECT Up button on the UDR700 to send the encryption key to the transmitter. Depending on the transmitter, the Power LED on the UT700 or the two Modulation LEDs on the UM700 blink to confirm receipt of the new key.

- Level 1: 1 blink
- Level 2: 2 blinks
- Level 3: 3 blinks

Note: In Security Levels 1 and 2, you may program as many transmitters as you like to match the receiver. Repeat steps 15 and 16 for each transmitter. This will transmit the same encryption key to each transmitter; however, once you leave this prompt, this particular encryption key can never again be sent out of the Security jack to a transmitter. A new encryption key will have to be created. In Security Level 3, each encryption key may be sent to only one transmitter.

- 17) Depending on the unit, hold the microphone for the belt pack transmitter or hold the hand held transmitter in the same position that it will be used in actual operation.
- 18) While speaking or singing at the same voice level that will actually be used, observe the Audio Level LEDs. Adjust the Audio Level control until the -20 LED occasional blinks red and the -10 LED glows steady green.

Signal Level	-20 LED	-10 LED
Less than -20 dB	Off	Off
-20 dB to -10 dB	Green	Off
-10 dB to +0 dB	Green	Green
+0 dB to +10 dB	Red	Green
Greater than +10 db	Red	Red



Note: Different voices will usually require different settings of the AUDIO LEVEL control, so check this adjustment as each new person uses the system. If several different people will be using the transmitter and there is not time to make the adjustment for each individual, adjust it for the loudest voice.

Note: In the UT700, if you find that the Audio Level control is set to minimum and the -20 LED still glows green, then adjust the preamp level control located under the microphone wind screen. (See VARIMIC™ CONTROLS.) If you adjust the preamp level control, you will need to repeat steps 19 and 20.

- 19) If you are using the UT700 hand held microphone, replace the Battery Compartment Cover.
- 20) Once the transmitter gain has been adjusted, the audio levels for the rest of the system can be set. Set the UDR700 Analog Audio Output Control to midrange.

Notes: The transmitter Audio Level Control should not be used to control the volume of your sound system or recorder levels. This gain adjustment matches the transmitter gain with the user's voice level and microphone positioning.

Note: The UDR700 receiver needs at least 5 uV of RF signal to begin operating - this is the approximate squelch threshold. Between 5 uV and 10 uV, reception will be marginal and brief gaps in the audio may occur if the receiver squelches. Check to see that at least the lowest four RF LEVEL LEDs stay lit when the transmitter is turned on.

- 21) Operate the wireless system and fine tune the receiver analog audio output level as required by your equipment. The input levels on different equipment vary. Try different settings of the Analog Audio Output Control to listen to the results. If the output of the receiver is too high, you may hear distortion or a loss of the natural dynamics of the audio signal. If the output is too low, you may hear steady noise (hiss) along with the audio.



Note: The -40 setting is approximately equal to 10 mV, the 0 position will give 0.775 VRMS, and the +15 setting will allow up to 4.4 VRMS when the transmitter is fully modulated. The correct setting will depend on the requirements of your sound or recording system.

- 22) If necessary, perform a walk test to map the effective operating range for the transmitter(s) prior to the beginning of the function.

Note: In Security Level 2, if you wander out of range for more than 10 seconds, the transmitter must be turned off, then on again to resynchronize with the receiver. In Security Level 3, if you wander out of range for more than 10 seconds, a new encryption key will have to be generated for the system to operate.

### Changing the Security Level

- 1) Determine the new security level. (See The 700 Series Encryption System.)
- 2) Press and hold the SELECT Down button while powering up the receiver. The display will show the current security level. (Default is Level 1.)
- 3) Use the SELECT Up or Down buttons to choose a new security level, then press the MENU button to finalize the security level selection process. The Information and Status Display will then display a message indicating the level of security (Level 1, 2 or 3). Pressing the MENU button again enters the key generation process.

Note: Changing security levels requires that a new key be sent to the transmitter(s) before the system will operate.

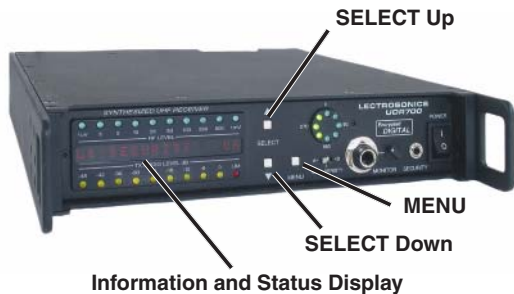

### Setting the Encryption Key

Note: In Security Levels 1 and 2, any number of transmitters can receive the same encryption key. In Security Level 3, only one transmitter may receive the encryption key. (See The 700 Series Encryption System.)

- 1) To set a new encryption key, press the MENU button to scroll through the menus until the SECURITY MENU is displayed in the Information and Status Display. Press MENU once more to enter the Key Generation Menu. "MAKE NEW KEY?" will be displayed in the Information and Status Display with an "Up" arrow to the message's right.
- 2) Press the SELECT Up button to create a new

encryption key (or press MENU to cancel creating a new key and return to the MAIN TUNING MENU display). Follow the directions on the Information and Status Display until the prompt "NEW KEY TO TX ^" is displayed.

- 3) Connect the appropriate Key Cable between the transmitter and the UDR700, then turn on the transmitter.

Note: Each transmitter uses a different Key Cable. (See Encryption Key Cables.)

- 4) Press the SELECT Up button on the UDR700 to send the encryption key to the transmitter. Depending on the transmitter, the Power LED on the UT700 or the two Modulation LEDs on the UM700 blink to confirm receipt of the new key.

Level 1: 1 blink

Level 2: 2 blinks

Level 3: 3 blinks

Note: In Security Levels 1 and 2, you may program as many transmitters as you like to match the receiver. Repeat steps 3 and 4 for each transmitter. This will transmit the same encryption key to each transmitter; however, once you leave this prompt, this particular encryption key can never again be sent out of the Security jack to a transmitter. A new encryption key will have to be created. In Security Level 3, each encryption key may be sent to only one transmitter.

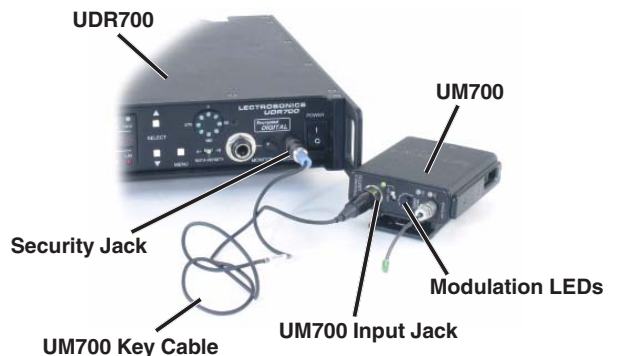
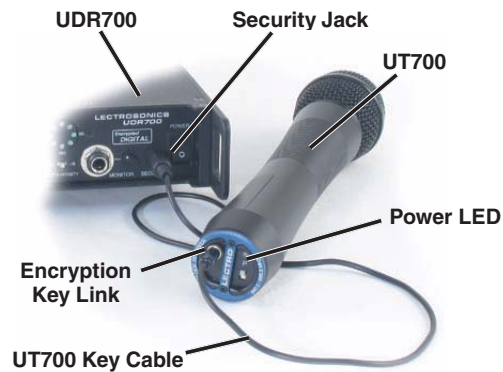

## Protecting the Encryption Key

The encryption key is never displayed, and once a key transfer session is complete, the existing key can never again be transferred out the receiver's security port. However, the key is stored inside the transmitter and the receiver, so you should treat the equipment as you would a key, storing it in a safe place for as long as the key is important.

Keep in mind that old keys could be used to decrypt old transmissions, if someone had the means and desire to make such recordings. Also, overwriting an old key with a new one does not necessarily place the old key beyond the reach of someone with unlimited resources if they can obtain your equipment. Amazing feats of data recovery from overwritten EEPROM chips have been demonstrated.

For maximum security, it is recommended that you set a new key often, ideally before and after each use of the system, and that you always store the equipment in a physically secure location.

Note that in Security Level 3, the equipment itself enforces the most important part of this policy, namely that no key shall ever be used more than once.

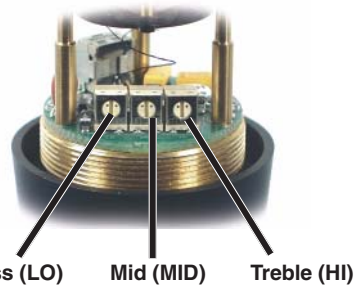

- Set flat (as shown in illustration), the mic capsule has a very wide dynamic range and sounds a lot like a large competitor's top line condenser mic.
- Bass cut gives a dry but highly intelligible sound. Crisp.
- Bass boost "fattens" the sound but is very listenable. Does not get midbass boomy.
- Midrange cut sounds very smooth, very sweet. Almost like a "crooner" quality.
- Midrange boost is likely to be useful in a system that is midrange shy.
- Treble cut has a "mellow" sound. The capsule has a solid high end so a little cut does not ruin the response.
- Treble boost might be fine on some sound systems. The sound doesn't get harsh (showing that the response was smooth) but sibilants are a little too much. Should be used in moderation.

## UT700 Vari-Mic™ Controls

**Caution: Due to the high RF levels surrounding the transmitter, the sound of the VariMic capsule may be temporarily affected if the metal windscreen is not in place. Always make the final decision about sound balance and quality with the windscreen in place.**

The VariMic™ head includes adjustments for the microphone element's Bass, Midrange and Treble response. There is also an attenuation adjustment to provide up to 15 dB of additional headroom if needed. These controls can be accessed by removing the windscreen. To remove the windscreen, grasp the body of the transmitter in one hand and the windscreen in the other hand. Unscrew the windscreen counterclockwise and then carefully slide the windscreen past the mic element.

### Bass / Mid / Treble (LO / MID / HI)

The bass and treble controls will boost/cut by up to approximately 8 dB while the Mid control will boost/cut up to about 6 dB. These controls operate as standard tone controls. Counterclockwise will reduce the response in that band and clockwise will provide a true boost.

UT200 Bass/Midrange/Treble Boost/Cut

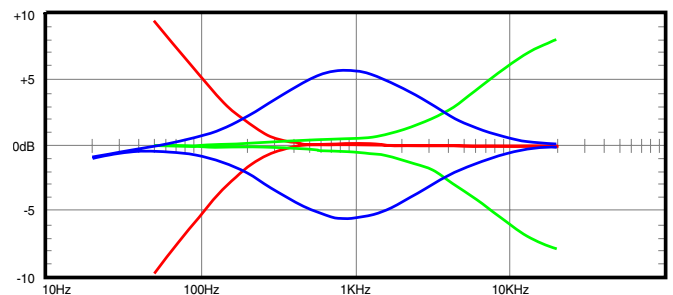

## Preamp Level Control

The VariMic™ head includes an attenuator to provide an additional 15 dB of headroom when needed. The attenuator should only be used when the normal Audio Level Control is already turned down as far as it will go and the signal through the mic is still too hot. The attenuator control is a 16-position switch marked 0 through F. “F” is minimum attenuation or the highest signal level. “0” is maximum attenuation or the lowest signal level. For the maximum amount of headroom, set the switch to “0.”



Preamp Level Control

**Note:** The attenuator should not be used as a level control. The Audio Level control inside the battery compartment is the main level control. Adjust the attenuator only when the Audio Level control is turned completely down and more headroom is still needed. Be sure to set the attenuator back to its original setting (minimum attenuation or “F”) for normal operation.

## Bass Filter

In addition to the tone controls, the UT700 also has a built in bass filter. This filter is fixed and cannot be adjusted or defeated. Low frequency noise is more of a problem with wireless microphones than with conventional microphones. With a regular mic, low frequency wind noise, breath thumps or handling rumble can be filtered out at the control board before the noise causes problems with the following electronic circuits or speaker systems. But with a wireless microphone, the electronics that will be overdriven are right in the wireless microphone. Filtering at the control board is much too late. To solve this problem, the VariMic has a low frequency filter that is so sharp that it can remove low frequency noise without affecting any wanted vocals. It consists of a 36 dB per octave filter circuit to sharply remove low frequency noise below 75 Hz without affecting vocal fundamentals.

VariMic Low Frequency Roll-off Filter

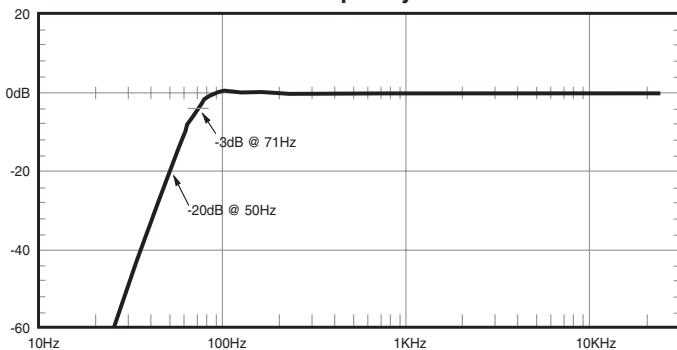

## 5-Pin Input Jack Wiring (UM700)

The wiring diagrams shown in Wiring Hookups For Different Sources represent the basic wiring configurations necessary for the most common types of microphones and other audio inputs. Some microphones may require extra jumpers or a slight variation in the diagrams shown.

It's virtually impossible to keep completely up to date on changes that other manufacturers make to their products. It is possible that you may encounter a microphone that differs from those illustrated. If this occurs please visit our web site (<http://www.lectrosonics.com>) or call our toll-free number listed in the back of this manual for assistance. Our Service Department can answer your questions regarding microphone compatibility.

When used on a wireless transmitter, the microphone element is in the proximity of the RF coming from the transmitter. The nature of electret microphones makes them sensitive to RF, which can cause problems with the microphone/transmitter compatibility. If the electret microphone is not designed properly for use with wireless transmitters, it may be necessary to install a chip capacitor in the mic capsule or connector to block the RF from entering the electret capsule. (See RF Bypassing.)

**PIN 1** - Shield (ground) for positive biased electret lavalier microphones. For the increasingly rare negative biased electret lavalier microphones, it is the bias voltage source. It is also the shield (ground) for dynamic microphones and line level inputs.

**PIN 2** - Shield (ground) for negative biased electret lavalier microphones. Bias voltage source for positive biased electret lavalier microphones.

**PIN 3** - Low impedance microphone level input for dynamic microphones. Also accepts hand-held electret microphones that have their own battery or power supply.

**PIN 4** - 4 k Ohm source load for non-Lectrosonics electret microphones. Use in conjunction with other pins to provide attenuation of high level input signals.

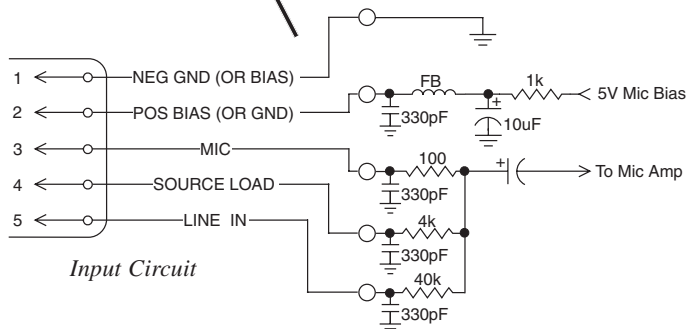
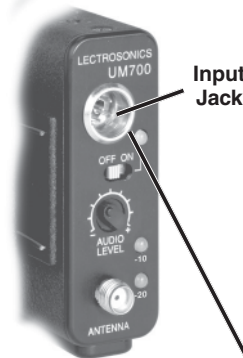



**PIN 5** - 40 k high impedance, line level input for tape decks, mixer outputs, musical instruments, etc.

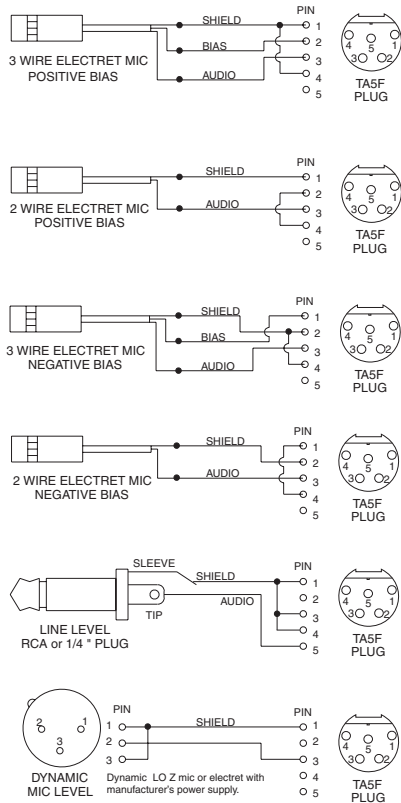

Wiring Hookups for Different Sources (UM700)

### RF Bypassing (UM700)

Some mics require RF protection to keep the transmitter signal from affecting the capsule, even though the transmitter input circuitry is already RF bypassed (see 5-Pin Input Jack Wiring schematic diagram ).

If the mic is wired as directed, and you are having difficulty with squealing, high noise, or poor frequency response, RF is likely to be the cause.

The best RF protection is accomplished by installing 330 pF bypass capacitors at the mic capsule. If this is not possible, or if you are still having problems, capacitors can be installed on the mic wires inside the TA5F connector housing.

The 330 pF capacitors are available from Lectrosonics.

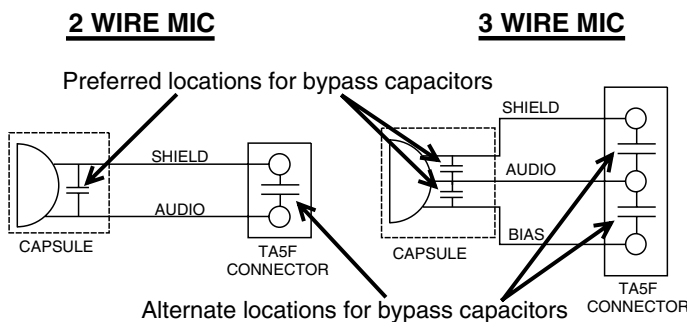

Please specify the part number for the desired lead style.

Leaded capacitors: P/N 15117  
Leadless capacitors: P/N SCC330P

Note: The M150-7005P microphone is bypassed correctly for use with the UM700 Encrypted Digital Transmitter and is the recommended lavalieri microphone for the 700 Series wireless microphone system.

### Line Level Signals (UM700)

The normal hookup for line level signals provides 40 dB of attenuation allowing signal levels up to 30 V to be applied without limiting. The normal hookup configuration can be modified for situations that require higher levels of headroom, or lower levels of attenuation.

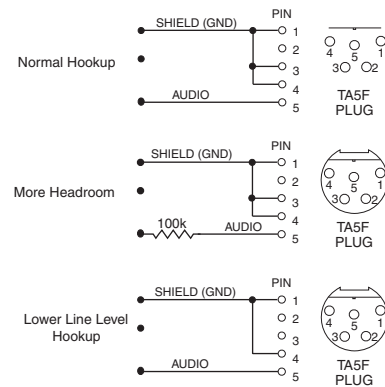

Normal hookup connects the Signal Hot (Audio) to pin 5, Signal Gnd (Shield) to pin 1, and both pins 3 and 4 jumped to pin 1.

If even more headroom is required, insert a 100 k resistor in series with pin 5 (Audio). Put this resistor inside the TA5F connector to minimize noise pickup.

For situations where lower than normal line levels (less than 1 V) are expected, use the Lower Line Level Hook Up: Signal Hot (Audio) to pin 5, Signal Gnd (Shield) to pin 1, and pin 4 jumpered to pin 1. This configuration provides 20 dB attenuation allowing signal levels up to 3 V to be applied without limiting.

### Encryption Key Cables

Each digitally encrypted transmitter uses a different encryption key cable. The configuration of these cables is listed below.

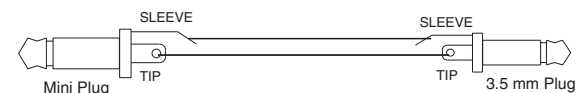

UT700KEY CABLE

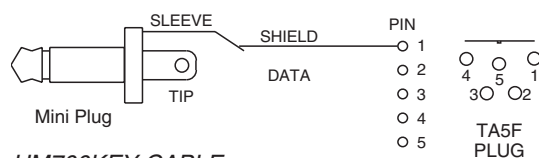

UM700KEY CABLE



# Troubleshooting

This manual applies only to UDR700 version 3.0/3.0 and higher.

## Power Problems

### UDR700

**Display not lit or dimly lit**

Power cord between main power supply and UDR700 disconnected or defective.  
 External power supply disconnected, defective or inadequate.  
 The External DC power input is protected by an auto-reset polyfuse. If external DC power is used, disconnect External DC power source and wait about 10 seconds for the fuse to reset, then reconnect power source.  
 Main power supply defective.

### UM700

**Power LED does not glow when transmitter Power ON/OFF Switch set to ON**

Battery is dead, or too low to be used.  
 Battery is inserted backwards.

**No Modulation LEDs**

Battery dead or in backwards. Check Power LED.  
 Audio Level Control turned all the way down.  
 Mic capsule is damaged or malfunctioning.  
 Mic cable damaged or mis-wired.

### UT700

**Power LED does not glow when transmitter Power On/Off Switch set to On**

Battery is inserted backwards.  
 Battery is dead, or too low to be used.

**No Modulation LEDs**

Battery dead or in backwards. Check Power LED.  
 Audio Level Control turned all the way down.  
 Mic capsule is damaged or malfunctioning. Contact the factory for repair.

## RF Problems

**Antenna Phase Combining Indicator on UDR700 has three LEDs glowing but never moves**

The ROTA-VERSITY switch is set to the A or B position (using only one antenna) instead of the normal, center position (using both antennas).  
 An antenna may be disconnected, have a bad connector or defective antenna cable.

**No LEDs glow on Receiver RF Level Indicator**

Receiver not turned on.  
 Transmitter not turned on, or battery is dead.  
 A receiver antenna may be disconnected, have a bad connector or defective cable.  
 Transmitter and receiver not on same frequency.  
 Transmitter antenna not connected. (UM700 only)  
 Operating range is too great.

**RF LEVEL is weak, but Antenna Phase Combining Indicator LEDs glow and move**

An antenna may have bad connector and damaged cable.  
 The antennas may need to be moved or reoriented.  
 Improper length of UHF whip antenna, or wrong antenna.  
 Transmitter is 100 kHz (one switch position) off from the receiver frequency.

## Audio Problems

**No audio output, audio leds blinking in sequence, LED display occasionally flashes "POWER TX OFF+ON" or "NEW KEY REQUIRED".**

System is operating in security level 2 ("POWER TX OFF+ON") or 3 ("NEW KEY REQUIRED") and is not synchronized. Either the receiver did not pick up the start of the transmission or the transmitter was out of reception range for more than ten seconds. To correct this condition in security level 2, simply turn the transmitter off and on again. In level 3, it will be necessary to generate a new key. (For detailed instructions on generating a new key, see SETTING THE ENCRYPTION KEY.)

**Receiver indicates RF but no audio, and problem is not encryption key**

Ensure that the transmitter and receiver are set to the same frequency.

Transmitter Audio Level Controls misadjusted.

**No sound (or low sound level), receiver indicates proper audio modulation**

Receiver output level set too low.

Receiver output disconnected, audio output cable is defective or connector is wired incorrectly.

Sound system or recorder input is turned down.

**Receiver outputs an extremely loud, hissy or swishy sound**

Encryption keys in transmitter and receiver do not match.

**Poor signal to noise ratio**

Transmitter gain set too low.

Noise may not be in wireless system. Mute the audio signal at the transmitter and see if noise remains. If the noise remains, then turn the power off at the transmitter and see if it remains. If the noise is still present, then the problem is not in the transmitter.

If noise is still present when the transmitter is turned off, try lowering the audio output level on the receiver rear panel and see if the noise lowers correspondingly. If the noise remains, the problem is not in the receiver.

Receiver output does not match the input of the device it is feeding.

Try increasing the output level of the receiver and lowering the input gain on the device the receiver is feeding.

**Hiss and noise, audible dropouts**

Transmitter gain (audio level) far too low.

Receiver antenna missing or obstructed.

Operating range too great.

Receiver and Transmitter Frequency Select Switches not set to the same channel.

RF interference. Reset both transmitter and receiver to a clear channel.

[Note: Resetting operating frequency will require resending encryption key in Security Level 3.](#)

**Distorted sound, motorboating**

Transmitter gain (audio level) is too high. Check Modulation LEDs on transmitter and receiver as transmitter is being used.

Receiver output may be mismatched with the sound system or recorder input.

Excessive wind noise or breath "pops." Reposition microphone, or use a larger windscreen (UT700), or both.

RF feedback getting into VariMic mic capsule. Ensure that the windscreen is present and screwed down snugly.

Transmitter is not set to same frequency as receiver.

RF interference. Reset both transmitter and receiver to a clear channel.

**Excessive feedback**

Transmitter gain (audio level) too high. Check gain adjustment and/or reduce receiver output level.  
Microphone too close to speaker system.  
Move microphone closer to the user's mouth, and lower the sound system volume.

**Microphone has a “whine” noise in the background which varies as the mic cable is moved. (UM700 specific)**

The 700 Series modulation has an AM component which is more easily detected than FM by sensitive audio circuits. A microphone that works fine on an FM system might not work on a 700 series system. To protect the microphone from RF it is necessary to bypass it effectively at both ends of the cable. Ensure that bypass capacitors are installed inside the connector housing. If the mic is not sufficiently bypassed at the capsule, it may be necessary to use a different type of microphone. The UM700 transmitter is shipped with an M150 microphone which should work.

---

Note: The microphone plug wiring is different for the UM700 transmitter than for other Lectrosonics models. The M150 microphone supplied with the UM700 transmitter will not work with Lectrosonics 185/187 Series VHF belt-pack transmitters.

# Specifications

## Overall System

<b>Latency:</b>	2.5 ms
<b>Operating principle:</b>	Proprietary digital modulation with encryption
<b>Modulation type:</b>	Modified pi/4 DQPSK
<b>Sample rate:</b>	44.1 ksp/s
<b>Audio coder:</b>	Proprietary sub-band ADPCM
<b>Encryption key length:</b>	128 bit (300 trillion trillion keys)
<b>Bit rate:</b>	220,500 bps including packet overhead
<b>Operating frequencies:</b> (depending upon local regulations)	Block 22      563.200 - 588.700 Block 23      588.800 - 607.900 and 614.100 - 614.300 Block 24      614.400 - 639.900 Block 25      640.000 - 665.500
<b>Frequency selection:</b>	256 frequencies in 100 kHz steps
<b>Frequency Adjustment Range:</b>	25.5 MHz
<b>System Specifications</b>	
<b>Audio frequency response:</b>	40 Hz to 20 kHz, +/- 1dB (with UM700 transmitter)
<b>Audio dynamic range:</b>	>100 dB before limiting
<b>Audio Distortion:</b>	0.05% THD + noise at 1 kHz

## UDR700 Digital Receiver

<b>Receiver Type:</b>	Double conversion, superheterodyne, 244 MHz and 10.7 MHz
<b>Frequency Stability:</b>	+/- 0.002%
<b>Front end selectivity:</b>	>22 dB at +/- 4 MHz
<b>Sensitivity:</b>	5 uV for 100 dB S/N ratio
<b>Squelch quieting:</b>	> 125 dB
<b>Image/Spurious rejection:</b>	> 100 dB
<b>Third order intercept:</b>	+12 dBm
<b>Diversity technique:</b>	Rota-versity antenna combining
<b>Antenna inputs:</b>	Dual BNC 50 Ohm
<b>Modulation Type:</b>	Modified pi/4 DQPSK
<b>Sample Rate:</b>	44.1 ksp/s
<b>Bit Rate:</b>	220,500 bps
<b>Audio Coder:</b>	Proprietary sub-band ADPCM
<b>Encryption Key Length:</b>	128-bit (over 300 trillion, trillion, trillion keys)
<b>Audio outputs:</b>	Analog: -40 dBu to +15 dBu Digital: AES-3id
<b>Monitor out:</b>	Front panel 1/4" jack; 0 to 110 mV RMS.
<b>Power Options:</b>	90 to 240 VAC, 50/60 Hz, 10 Watts 11 to 17 VDC, 10 Watts
<b>Weight:</b>	3 lbs., 9 ozs.
<b>Dimensions:</b>	8.2" wide x 1.73" high x 10.6" deep

## UM700 Digital Transmitter

<b>RF Power output:</b>	50 mW (nominal)
<b>Frequency stability:</b>	± 0.001%
<b>Equivalent input noise:</b>	-119 dBV, A-Weighted
<b>Spurious radiation:</b>	70 dB below carrier
<b>Input Level:</b>	Nominal 2 mV to 300 mV before limiting Greater than 1V maximum with limiting
<b>Input impedance:</b>	Taps provided for 100, 4k, 40k Ohm
<b>Input compressor:</b>	Dual-envelope limiter; 30 dB range
<b>Gain control range:</b>	43 dB; semi-log rotary control
<b>Modulation indicators:</b>	Dual multi-color LEDs indicate modulation level in 4 steps at -20, -10, 0, +10 dB with green and red indications
<b>Low frequency roll-off adjustment:</b>	-18 dB/octave; 35 Hz to 150 Hz

<b>Controls:</b>	2 position "ON-OFF" slide switch. Front panel knob adjusts audio gain. Recessed control on side panel adjusts low frequency rolloff. Rotary switches on side panel adjust transmitter frequency.
<b>Audio Input Jack:</b>	Switchcraft 5-pin locking (TA5M)

Note: The M150-7005P microphone is bypassed correctly for use with the UM700 Encrypted Digital Transmitter and is the recommended lavalier microphone for the 700 Series wireless microphone system.

<b>Antenna:</b>	Detachable, flexible 1/4 wave insulated bronze cable. 50 Ohm port allows connection to test equipment.
<b>Battery:</b>	Precision compartment auto-adjusts to accept any known alkaline 9 Volt battery.
<b>Battery Life:</b>	4 hours (alkaline); 7.5 hours (lithium)
<b>Weight:</b>	6.3 ozs. including battery
<b>Dimensions:</b>	3.1 x 2.4 x .75 inches
<b>Emission Designator:</b>	180KQ2E

The FCC requires that the following statement be included in this manual:

This device and its antenna(s) must operate with a separation distance of at least 2.5 cm from all persons and must not be co-located or operating in conjunction with any other antenna or transmitter.

## UT700 Digital Transmitter

<b>RF Power output:</b>	50 mW (nominal)
<b>Frequency stability:</b>	± 0.001%
<b>Spurious radiation:</b>	70 dB below carrier
<b>Input compressor:</b>	Dual-envelope limiter; 30 dB range
<b>Gain control range:</b>	43 dB; semi-log rotary control
<b>Modulation indicators:</b>	Dual multi-color LEDs indicate modulation level in 4 steps at -20, -10, 0, +10 dB with green and red indications
<b>Controls:</b>	2 position "ON-OFF" slide switch. Knob in battery compartment adjusts audio gain. Rotary switches in battery compartment adjust transmitter frequency.
<b>Battery:</b>	Precision compartment auto-adjusts to accept any known alkaline 9 Volt battery.
<b>Battery Life:</b>	3.5 hours (alkaline); 6.5 hours (lithium)
<b>Weight:</b>	12.4 ozs. with VariMic™ cardioid capsule and lithium battery
<b>Dimensions:</b>	9" long, x 2.05" diameter at largest point with VariMic™ cardioid capsule
<b>Emission Designator:</b>	180KQ2E

The FCC requires that the following statement be included in this manual:

This device and its antenna(s) must not be co-located or operating in conjunction with any other antenna or transmitter.

*Specifications subject to change without notice.*



## Replacement Parts and Accessories

<b>Part No.</b>	<b>Description</b>
<b>A500RA</b>	Right angle, flexible whip UHF antenna
<b>A600</b>	Log Periodic Dipole Array antenna
<b>A700A</b>	Log Periodic Dipole Array antenna
<b>AMMxx</b>	Precut UHF antennas cut to specific blocks with SMA jacks.
<b>AMM Kit</b>	UHF antenna for UHF belt-pack transmitters with SMA jacks. Cut to frequency with supplied template.
<b>21499</b>	Replacement AC power cord (US NEMA Type Plug)
<b>M150-7005P</b>	Replacement lavalier microphone for UM700 transmitter
<b>RMP200-1</b>	Rack mount kit for single UDR700 receiver
<b>RMP200-2</b>	Rack mount kit for two UDR700 receivers
<b>UM700 Key Cable</b>	Encryption Key setup cable for UM700 Transmitter
<b>UT700 Key Cable</b>	Encryption Key setup cable for UT700 Transmitter
<b>ARG2 - ARG100</b>	Coaxial cables for remote antennas with BNC connectors on both ends
<b>MC40</b>	Audio cable adapter-Female XLR to TA5F 5-pin
<b>A4F</b>	4-pin XLR plug for making External DC Power Cable for UDR700
<b>BCWIRE</b>	Replacement belt clip for UM700
<b>35804</b>	Transmitter pouch for all hand-held transmitters



## Service and Repair

If your system malfunctions, you should attempt to correct or isolate the trouble before concluding that the equipment needs repair. Make sure you have followed the setup procedure and operating instructions. Check the interconnecting cables and then go through the **Troubleshooting** section in this manual.

We strongly recommend that you **do not** try to repair the equipment yourself and **do not** have the local repair shop attempt anything other than the simplest repair. If the repair is more complicated than a broken wire or loose connection, send the unit to the factory for repair and service. Don't attempt to adjust any controls inside the units. Once set at the factory, the various controls and trimmers do not drift with age or vibration and never require readjustment.

**There are no adjustments inside that will make a malfunctioning unit start working.**

LECTROSONICS' Service Department is equipped and staffed to quickly repair your equipment. In warranty repairs are made at no charge in accordance with the terms of the warranty. Out-of-warranty repairs are charged at a modest flat rate plus parts and shipping. Since it takes almost as much time and effort to determine what is wrong as it does to make the repair, there is a charge for an exact quotation. We will be happy to quote approximate charges by phone for out-of-warranty repairs.

### Returning Units for Repair

For timely service, please follow the steps below:

- A. DO NOT return equipment to the factory for repair without first contacting us by letter or by phone. We need to know the nature of the problem, the model number and the serial number of the equipment. We also need a phone number where you can be reached 8 A.M. to 4 P.M. (U.S. Mountain Standard Time).
- B. After receiving your request, we will issue you a return authorization number (R.A.). This number will help speed your repair through our receiving and repair departments. The return authorization number must be clearly shown on the **outside** of the shipping container.
- C. Pack the equipment carefully and ship to us, shipping costs prepaid. If necessary, we can provide you with the proper packing materials. UPS is usually the best way to ship the units. Heavy units should be "double-boxed" for safe transport.
- D. We also strongly recommend that you insure the equipment, since we cannot be responsible for loss of or damage to equipment that you ship. Of course, we insure the equipment when we ship it back to you.

**Mailing address:**

Lectrosonics, Inc.  
PO Box 15900  
Rio Rancho, NM 87174  
USA

**Shipping address:**

Lectrosonics, Inc.  
581 Laser Rd.  
Rio Rancho, NM 87124  
USA

**Telephone:**

(505) 892-4501  
(800) 821-1121 Toll-free  
(505) 892-6243 Fax

**Web:**

[www.lectrosonics.com](http://www.lectrosonics.com)

**E-mail:**

[sales@lectrosonics.com](mailto:sales@lectrosonics.com)

# Microphone Cord Termination

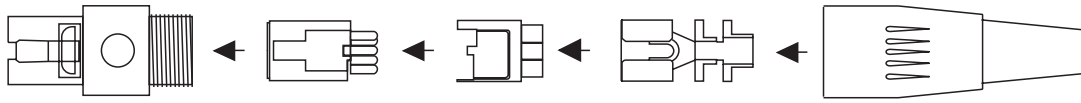

**TA5F Connector Assembly**

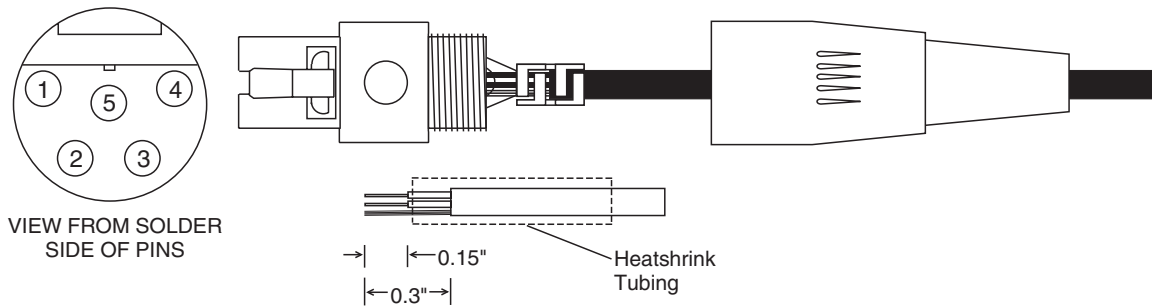

**Mic Cord Stripping Instructions**

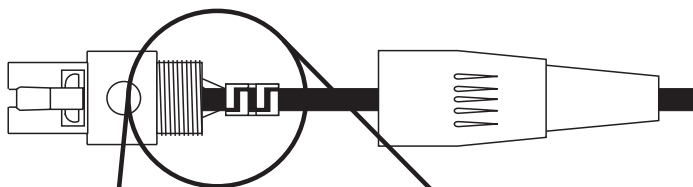

Be sure the shield wire touches the metal crimp tab. This helps prevent any AM component of the transmitter signal from entering the mic and causing a "whine."

Note that this is opposite from our VHF transmitter wiring where the shield should not touch any metal part of the housing.

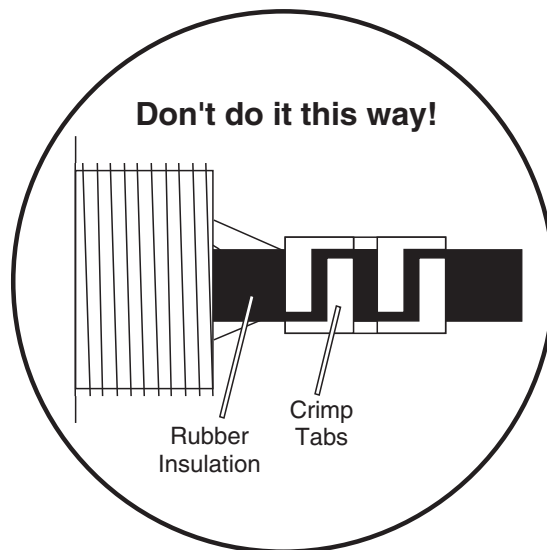
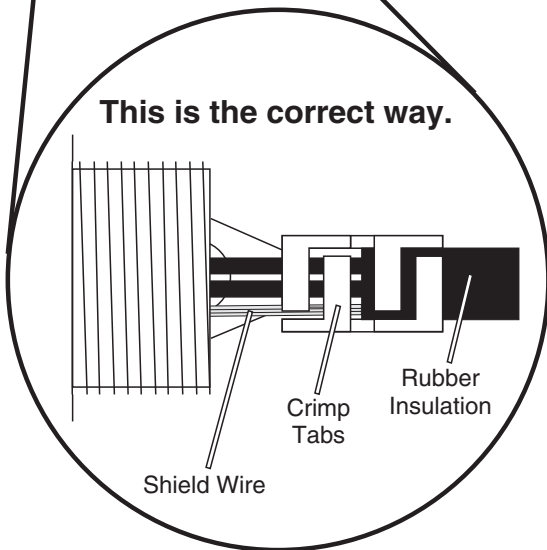



## LIMITED ONE YEAR WARRANTY

The equipment is warranted for one year from date of purchase against defects in materials or workmanship provided it was purchased from an authorized dealer. This warranty does not cover equipment which has been abused or damaged by careless handling or shipping. This warranty does not apply to used or demonstrator equipment.

Should any defect develop, Lectrosonics, Inc. will, at our option, repair or replace any defective parts without charge for either parts or labor. If Lectrosonics, Inc. cannot correct the defect in your equipment, it will be replaced at no charge with a similar new item. Lectrosonics, Inc. will pay for the cost of returning your equipment to you.

This warranty applies only to items returned to Lectrosonics, Inc. or an authorized dealer, shipping costs prepaid, within one year from the date of purchase.

This Limited Warranty is governed by the laws of the State of New Mexico. It states the entire liability of Lectrosonics Inc. and the entire remedy of the purchaser for any breach of warranty as outlined above. NEITHER LECTROSONICS, INC. NOR ANYONE INVOLVED IN THE PRODUCTION OR DELIVERY OF THE EQUIPMENT SHALL BE LIABLE FOR ANY INDIRECT, SPECIAL, PUNITIVE, CONSEQUENTIAL, OR INCIDENTAL DAMAGES ARISING OUT OF THE USE OR INABILITY TO USE THIS EQUIPMENT EVEN IF LECTROSONICS, INC. HAS BEEN ADVISED OF THE POSSIBILITY OF SUCH DAMAGES. IN NO EVENT SHALL THE LIABILITY OF LECTROSONICS, INC. EXCEED THE PURCHASE PRICE OF ANY DEFECTIVE EQUIPMENT.

This warranty gives you specific legal rights. You may have additional legal rights which vary from state to state.

