

West Seattle Connection

# World's Only Hydraulically Operated Double-Leaf Concrete Swing Bridge



Seattle Engineering Department  
Seattle, Washington

National Society  
of  
Professional Engineers

---

**Outstanding  
Engineering Achievement Award**

---

**1991 Nomination  
Seattle Low-Level West Seattle Bridge**

City of Seattle  
Seattle, Washington

## **SUMMARY**

On August 9, 1991, the Seattle Engineering Department made bridge-building history. That date marked the grand opening of a project in which engineering innovation was used to meet community and industry needs - the West Seattle double-leaf, concrete swing bridge.

The requirements of a bridge for this particular crossing mandated a new and untried concept and design. The old bascule bridge, whose piers were demolished using a specially created "air curtain" to protect aquatic life from the force of the in-water blast, provided too narrow a passage for this major industrial waterway. Engineers and designers developed a design based on channel width and horizontal clearance, utilization of existing roadway approaches, seismic integrity, and aesthetics.

Among the many design innovations in this one-of-a-kind structure are:

- concrete box leaves of unprecedented span length.
- a hydraulic oil system to lift the 7,500 ton leaves before their forty-five degree rotation.
- seismic isolation sleeves.

These and other design elements enabled the design team, headed by the consulting firm of Andersen Bjornstad Kane Jacobs, Inc., to create a movable bridge of enormous reach that provides safer navigation to ships while connecting an important network of marine terminals to city surface transportation systems.

As can be seen in the accompanying pictures, utility, design innovation, and aesthetic appeal are wedded in this bridge. It is a graceful span that provides the general community with amenities other than basic transportation. It has a dedicated bicycle and pedestrian lane as part of an overall vision of a Seattle waterfront trail. It provides recreational access to parklike settings on the Duwamish River. It is an outstanding achievement on many levels.

## Overview

The West Seattle Swing Bridge is a bridge-building first - the one hydraulically operated, double-leaf concrete swing bridge in the world. This \$33.5 million dollar project, completed in 1991, spans the West Waterway of the Duwamish River in the City of Seattle. The bridge provides an extremely important vehicular transportation arm connecting a network of marine terminals in the port area of Seattle.

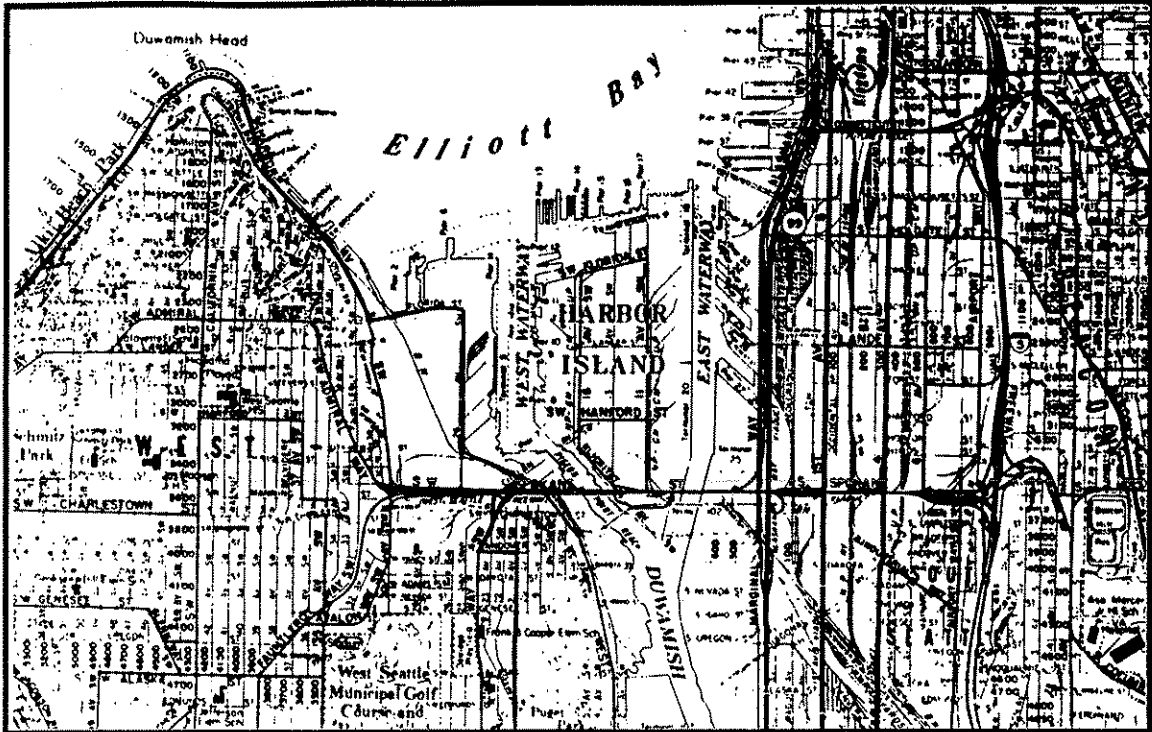

The bridge spanning the Duwamish River's West Waterway provides an extremely important vehicular arm connecting a network of marine terminals with interstate highways.

The swing bridge replaced a shorter steel bascule span constructed in the 1930's that restricted the width of the waterway and presented a risk to the navigation of large ocean going vessels.

The Duwamish Waterway Improvement plan prepared by the Seattle District Corps of Engineers prescribed a minimum horizontal clearance of 250 feet perpendicular to the waterway between pier protection. This translated to a span length of at least 353 feet. For engineers, this was an enormous reach for a movable bridge.

Preliminary design proposals were prepared in 1984 in a fiscal and political climate that saw local governments with drastically shrinking federal funds, concerned with maintenance of an existing and aging infrastructure. There was little enthusiasm for building new capital projects. The challenge met by the design engineers was the selection of a cost effective type of span and alignment to accommodate a channel crossing of near record distance for a movable bridge.

The double-leaf arrangement with a pivot pier on each bank solved many of the problems facing the engineers. The design met the span requirements for a wider channel, which would have been difficult with a bascule bridge. Having two pivot piers removed the obstructing single pier in the center of the channel used by a single span swing bridge. The

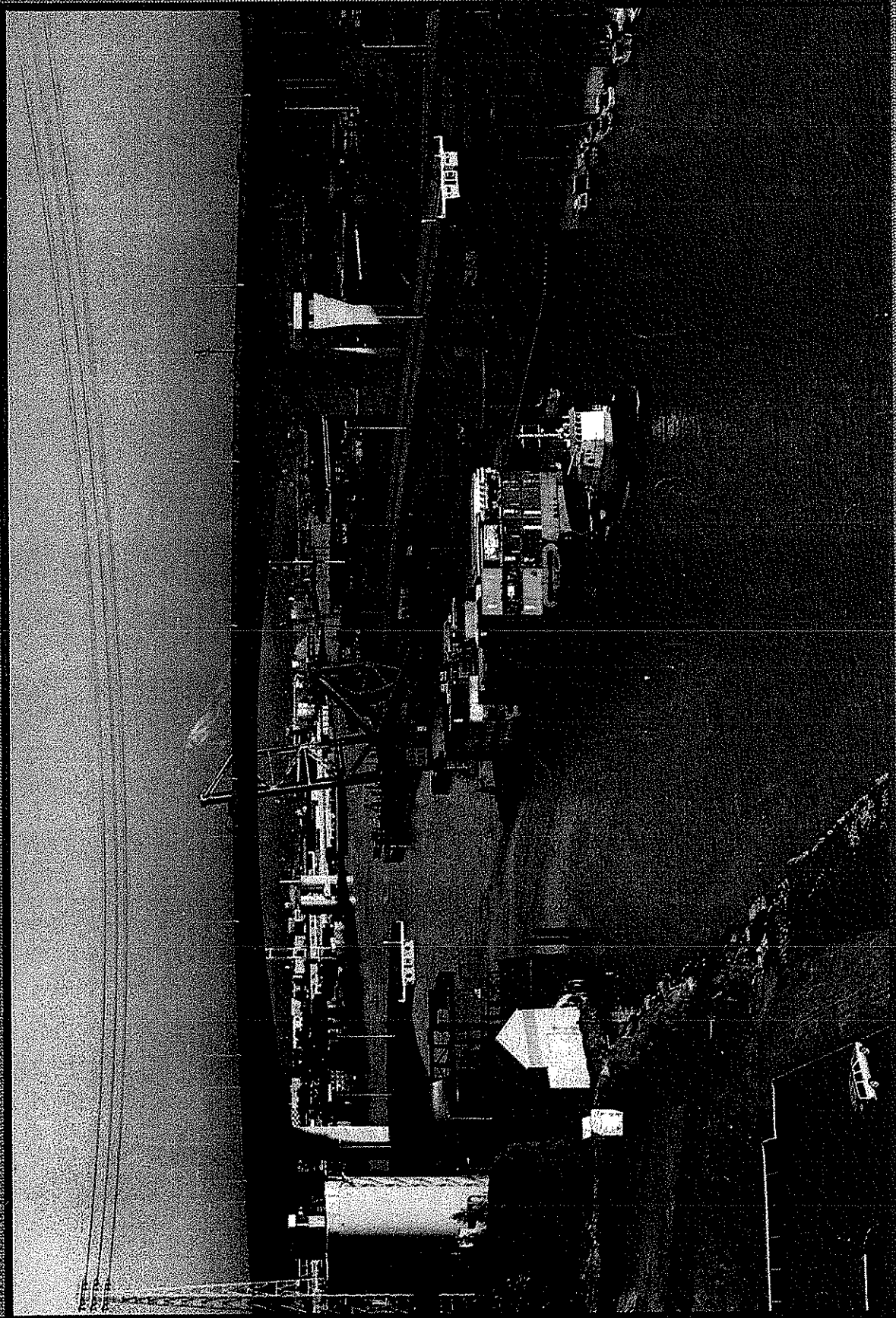

# Table of Contents

## Summary Overview

### Originality/Innovation

- Choosing a Design
- Fiscal
- Political
- Engineering Challenges
- Redundancy Safeguards
- Construction Challenges
- Bicycle and Pedestrian Dilemma

### Complexity

- Seismic Design
- Control System
- Movable Bridge Design
  - Pivot Shaft
  - Hydraulic Slewing Cylinder
- Tolerances

### Application of Engineering Principles

- Soil Densification
- Segmental Construction
- Superplasticizers

### Importance to Industrial Development

- Transportation for Industrial Area
  - Vehicular Traffic
  - Marine Traffic
- Industrial Development Potential
- Boater Safety
- Protection of Fish Resources

### Social Significance

- Improved Traffic
- Pedestrian and Bicycle
- River Access
- Environmental and Recreational
- Financial

### Support Information

- Facts Sheet
- Headliners
- *Seattle Slews Long, Heavy Span*, ENR Feature, October, 1991
- *Seattle Swing*, Civil Engineering, September, 1990

design was cost effective because existing right-of-way could be used, given that the axis of the span is skewed 45 degrees to the navigation channel. The span could be built in the open position, leaving the channel clear for shipping. Since this solution fit the project needs so well, the remaining task was to find a way to make it work.

There are many design innovations in this one-of-a-kind structure. The concrete box leaf with its unprecedented span length, the use of an oil hydraulic system to lift the 7,500 ton concrete leaves, and the seismic isolation sleeves are some of the design features that make this bridge stand out. Using a half-scale model of the lift-turn pistons and computers to simulate 10 years' use, project engineers assured public officials, an engineering peer review consultant and themselves that their design would hold up.

Construction and pre-construction demands were monumental in a site where major industrial traffic moved in and out at all times of the day and night. An electrical tower that provided electricity to a community of 70,000 people was moved without the loss of power. Water and telephone service continued uninterrupted to this community while these utilities were relocated from the new bridge alignment. The unstable soil would not support a structure in the event of significant seismic activity. Geotechnical technology was used to stabilize the area and provide protection and safety in the event of a major earthquake.

Addressing the concerns of diverse groups posed an immense challenge. Major detours were implemented in the industrial area disrupting traffic during construction. Regular newsletters were distributed and a construction "hot line" was established for regular updated construction information. A design/construction oversight committee comprised of members from the community, businesses and local government agencies periodically met to discuss project progress.

Two reinforced concrete piers remaining from the old bascule bridge were demolished with explosives using a new approach devised to protect the marine fisheries resources in the river. Pedestrians and bicyclists lost access through the corridor when the old bridge was removed. Transportation through the corridor using a van/shuttle was provided for over 64,000 bicyclists and pedestrians during construction. Appearance was an important consideration to the community. The swing bridge's low, graceful curve, nestled in the shadow of an existing high-level bridge, complements the city scape.

Political, environmental, geotechnical and community issues were met through the design and construction methods used in this project. The City of Seattle honored its commitment to the community, to bicycle and recreational users and to the Port Authority by producing an extremely functional structure of graceful proportions for the benefit of the City's industries, businesses and its citizens.

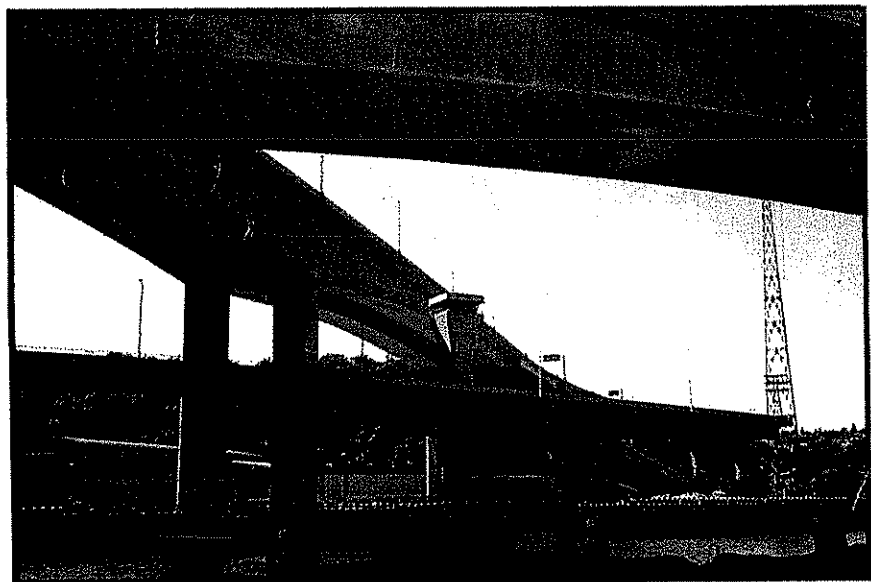

Each concrete box leaf span weighing 7,500 tons is lifted 1 inch using an oil hydraulic system.

## Originality/Innovation

Throughout the Seattle Swing Bridge's design and construction process a diverse, multi-disciplinary team addressed immense challenges - fiscal, political, environmental, geotechnical and societal issues.

**Choosing a Design** - Three alternatives were evaluated to accommodate a channel crossing of near record distance - namely bascule, vertical lift or swing span. The swing bridge was chosen because it provided greater horizontal clearance and cost less than a bascule design. It also best fit the available site and matched the aesthetics of the adjacent high level bridge.

**Fiscal** - The process that led to the selection of the swing design was not without challenges. Costs were addressed through the design process. Two double-leaf swing bridge alternative designs, one in segmental concrete and one in composite concrete and steel, were offered to bidders. Two swing bridges with different materials increased competition resulting in a favorable bidding climate and lower construction bids.

When the caveat was raised that no one had built such a heavy swing bridge before, the Federal Highway Administration declined to fund the swing bridge. It did, however, become a funding partner with a \$7.2-million contribution for approaches.

**Political** - Innovations in the project led to feelings of uneasiness in the City's elected officials. No one was sure if the lift-turn pistons would work. A half-scale model was constructed and hooked through a computer to simulate 10 years' use. The model, taken apart after the testing, showed no wear on seals or surfaces.

**Engineering Challenges** - Design engineers decided the great weight would best pivot on a pool of oil and developed the lifting concept. Normally a swing bridge pivots on a center bearing, but the weight of this bridge would require bronze bearings of incredible size and would eventually make flat spots on the balance wheels. Hydraulics for lifting and

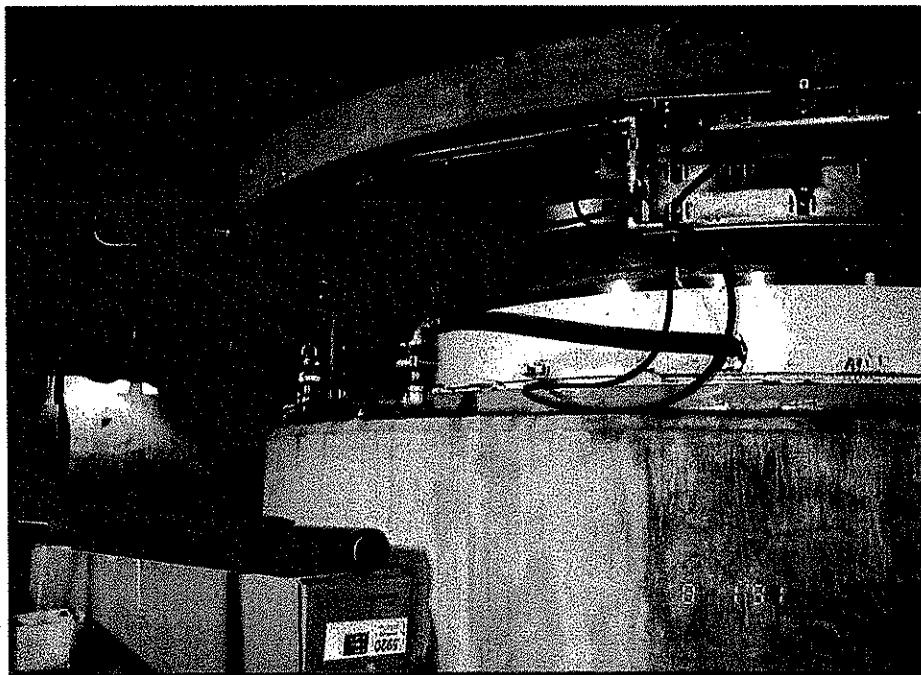

Hydraulic lift/turn cylinder used to raise each leaf off service bearings for 45 degree rotation to open and close bridge



pivoting the leaves were designed. A nine foot diameter hydraulic cylinder lifts the bridge off its service bearings and provides an oil bearing on which the bridge leaf rotates. Hydraulic cylinders are also used to rotate the leaves the 45 degrees required to clear the channel and to drive and retract the center and tail locks.

**Redundancy Safeguards** - In each pier house, two of three 100 hp, 125 gpm hydraulic pumps supply the power to raise and rotate the movable leaf. The designation of the third as a spare is rotated among the three. A spare lift-turn cylinder was also constructed.

Other redundancies built into the system include the ability to move the bridge on only one slewing cylinder or even move it against the friction of the service bearings should the lift-turn cylinder fail to operate. These maneuvers have to be done slowly, and the latter only in an extreme emergency. It requires manual overrides of pressure relief valves in the hydraulic system and would damage some of the service bearings. In the event of a power failure, emergency generators in the pilot piers would "come on line" to operate the bridge.

Although the design of the locks allows them to be driven against a 1 inch misalignment, the box girder has enough torsional stiffness so that locks are required only at the center line. The midstream and tail locks are driven and pulled by local hydraulic cylinders operated by separate pumps.

**Construction Challenges** - The swing bridge replaced a shorter steel bascule span built in 1930 that restricted the width of the shipping channel. Its piers presented a risk to the navigation of large ocean going vessels. It was necessary to remove these reinforced concrete pier foundations. Extensive coordination was required with the Washington State Department of Fisheries (WSDOF) and Indian tribal groups because the river is used for

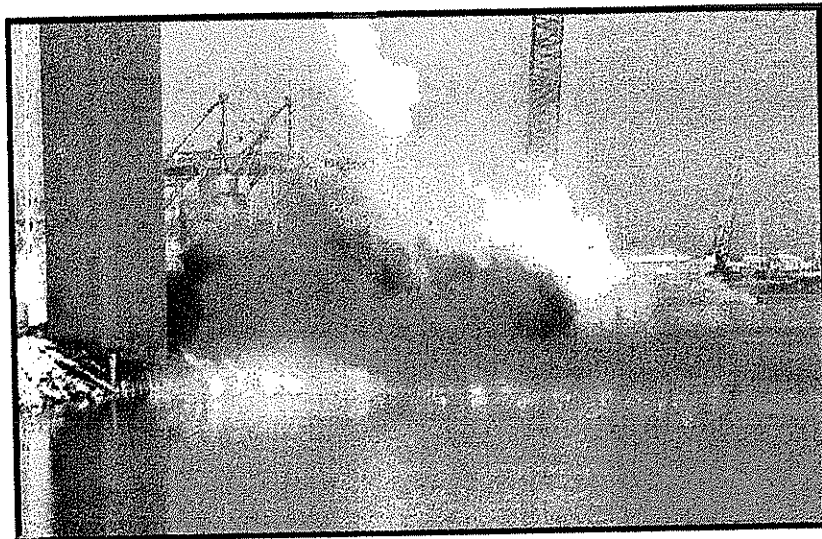

Blasting to remove old bascule bridge pier on west side

migration of sport and commercial fish, namely salmon and steelhead. A "fish window" was established by WSDOF that precluded in-water construction work between March 15 and June 15. A special monitoring program and construction procedure was proposed by the City and consultant in a effort to minimize any impacts from blasting to remove the piers. The contractor fabricated an "air curtain" using polyvinyl chloride pipe with drilled holes that was connected to high pressure air pumps and lowered into the water around each pier. The curtain of air produced is estimated to have absorbed up to 80 percent of the pressure wave created by each in-water blast. The "air-curtain" and pre- and post- blast hydroacoustical monitoring of fish was a successful procedure that resulted in no detectable loss of salmon or steelhead. WSDOF personnel were present during blasting and were pleased

with the results. The positive "air curtain" data provides a procedure for use in future projects where protection of a resource, such as fish, is highly important.

**Bicyclist and Pedestrian Dilemma** - During construction of the new swing bridge the former bascule bridge was removed. This left bicyclists and pedestrians without direct access across the Duwamish River. The Seattle Engineering Department solved this dilemma by contracting with a vendor to provide a van/shuttle for bicycles and pedestrians until the new swing bridge opened for traffic. The van/shuttle operated sixteen hours every day, between 6:00 a.m. and 10:00 p.m., to give a free ride across the high-level bridge. A special trailer with bicycle racks was furnished by the City. During the twenty-six months of operation, the van/shuttle carried over 64,000 bicycles.

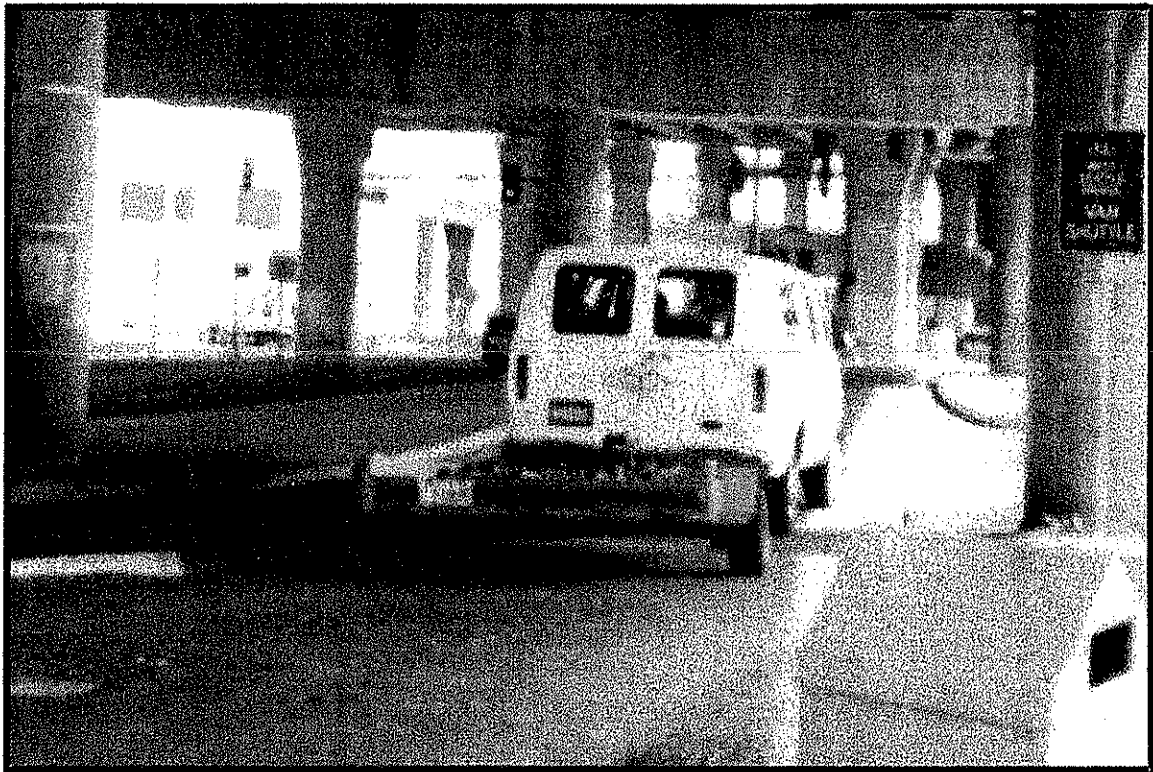

Van/shuttle left pick-up points every 20 minutes, 16 hours each day.

## Complexity

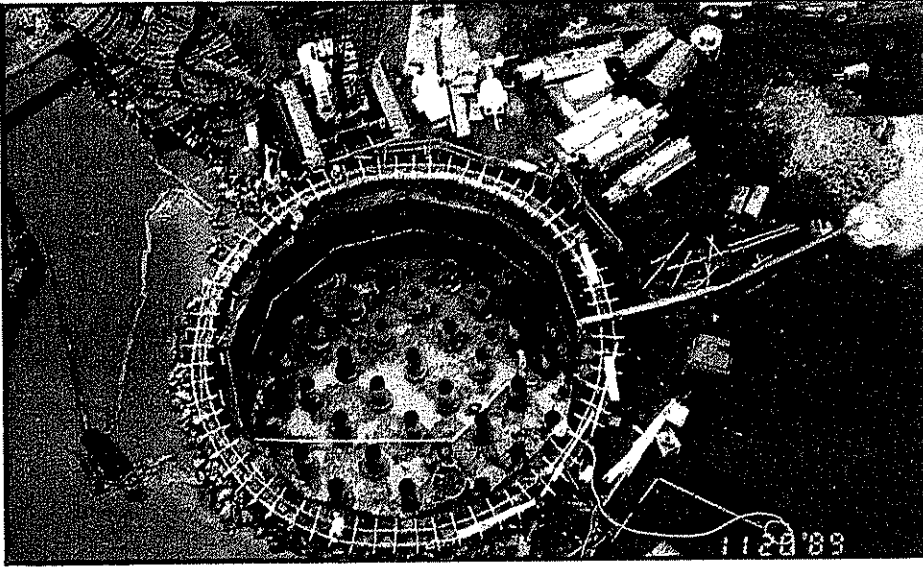

East mainspan pier (Pier 7) after placement of 36" pipe piles, 48" isolation sleeves and cofferdam seal.

**Seismic Design** - Because the Seattle area is moderately active seismically, designated UBC Zone III, seismic design was an important consideration. The bridge crosses the Duwamish River near its mouth, supported by piles that penetrate soils ranging from hydraulic fill and recent alluvial sands and silts to heavily preconsolidated glacial till. Depth to the till varies from 50 feet on the west to 200 feet on the east. There are lenses of loose silt scattered throughout the alluvium layer, and loose surface silts and the hydraulic fill are subject to liquefaction and potential ground subsidence in a severe earthquake. Vibroflotation to densify the problem soils was specified to prevent loss of lateral containment of soil around the upper portion of piles in the event of significant ground motion. The design for seismic response required consideration of several different interdependent elements - approaches, movable leaves, piers, and locks. Seismic design details also include "seismic isolation sleeves" around the piles on the main piers. Each of the foundation piles is encased in a 48 inch diameter steel pipe sleeve that controls the elevation at which the piles begin to receive lateral support from the surrounding soils.

**Control System** - The control system for operation provides for a complex interlocking of events required for operation. A carefully orchestrated sequence of operation was planned in which succeeding



Bridge Operator Control Console

operations could not be started until the predecessor was complete and checked by the system. This assured that all traffic and pedestrian safety gates were in place before the locks could be withdrawn. The bridge operator is provided with a programmable controller that sequences all operations and provides complete status information. The primary position control uses limit switches that initiate braking via the controller. The dynamics of the operating structure - large inertia, low damping - were deemed unsuitable for dynamic feedback control. The control system is essentially the same as manual operation except that the electronic controller "pushes the buttons," checks interlocks and announces the status on a monitor. The human operator, however, can interrupt most of the steps with manual override.

**Movable Bridge Design** - The pier table of each leaf is supported by a transition element that provides two load paths to the foundation. When the bridge is open to vehicular traffic, the load path goes from the superstructure pier table through a conical shell to the walls of the pier house. Service bearings composed of steel plates with reinforced elastomers separate the transition element from the roof of the pier house.

In the operating position, the entire movable leaf, including the transition element and pivot shaft, is raised about 1 inch to transfer the load from the service bearings to the pivot shaft. The load path is from the pier table through the center portion of the transition element to the 12 foot diameter pivot shaft, a

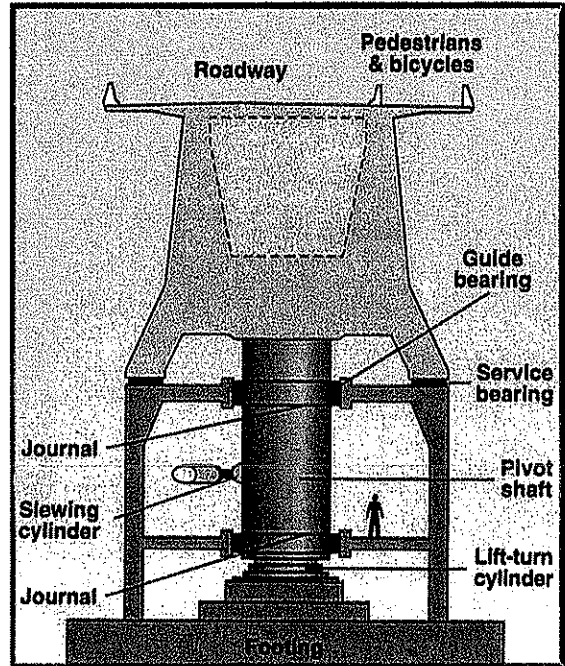

Shaft rises and pivots to turn 7,500-ton bridge leaf.

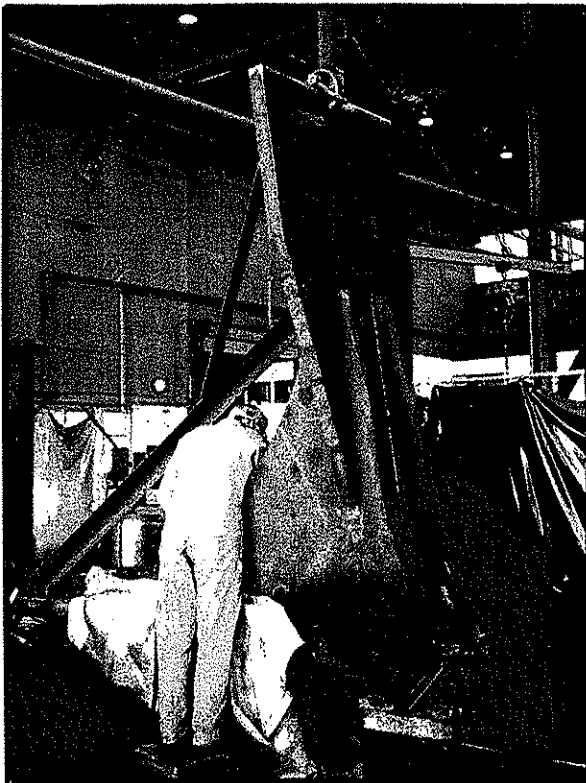

Slewing cylinder connection during fabrication

concrete-filled steel shell resting on the hydraulically operated lift-turn cylinder. The shaft is kept in the vertical position by guide bearings at the roof and operating floor of the pier house.

To complete load paths, a reinforced concrete footing is founded on 36 inch diameter concrete-filled steel pipe piles. The 42 foot diameter pier houses that carry the superstructure loads to the foundation are built with 32 inch thick concrete walls. They house the drive machinery, emergency generators and part of the control system.

To open the bridge, a hydraulic slewing cylinder with a 24 inch diameter piston and 92 inch stroke rotates each movable leaf to the full open position. Because the total weight of each box-girder leaf is suspended on the hydraulic fluid of the lift-turn cylinder, frictional

resistance to rotation is limited to the minimal amount from the pivot shaft in contact with the vertical-alignment guide bearings.

**Tolerances** - The tolerances specified for the manufacture and setting of the mechanical components of the bridge were not typical bridge-building tolerances. They were more similar to the closer and more precise specifications used for turbines and generators. Despite this rigorous demand, the machinery manufacturer and contractor met and surpassed the specified tolerances in all respects.

The 12 foot diameter pivot shafts were made in three sections, machined and assembled in the shop and subjected to a run-out test on a horizontal axis. The two journals were circular within four thousandths (0.004") of an inch. The base of the cylinder was perpendicular to the axis within seven thousandths (0.007") of an inch.

The cylinders were disassembled, transported and reassembled on the lift-turn cylinders in the bridge. After careful plumbing, they were again subjected to a run-out test in the vertical axis. The results obtained in the shop were duplicated in the bridge before and after being filled with concrete.

Similar tolerances were met in setting the lift-turn cylinders and service bearing race.

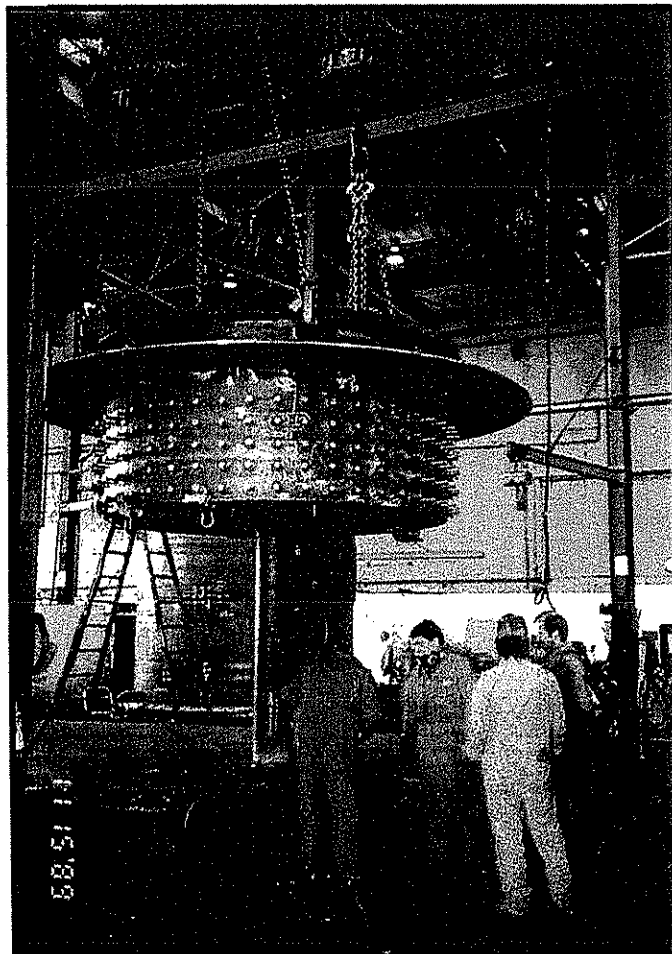

Fabrication of lower pivot shaft section at  
Nicholson Manufacturing Company.

**FIGURE 2.**  
**PIVOT PIER**

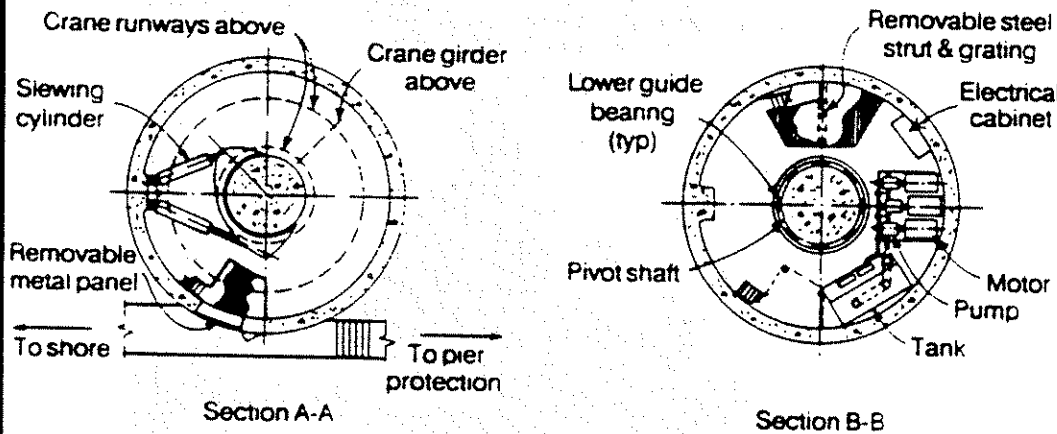
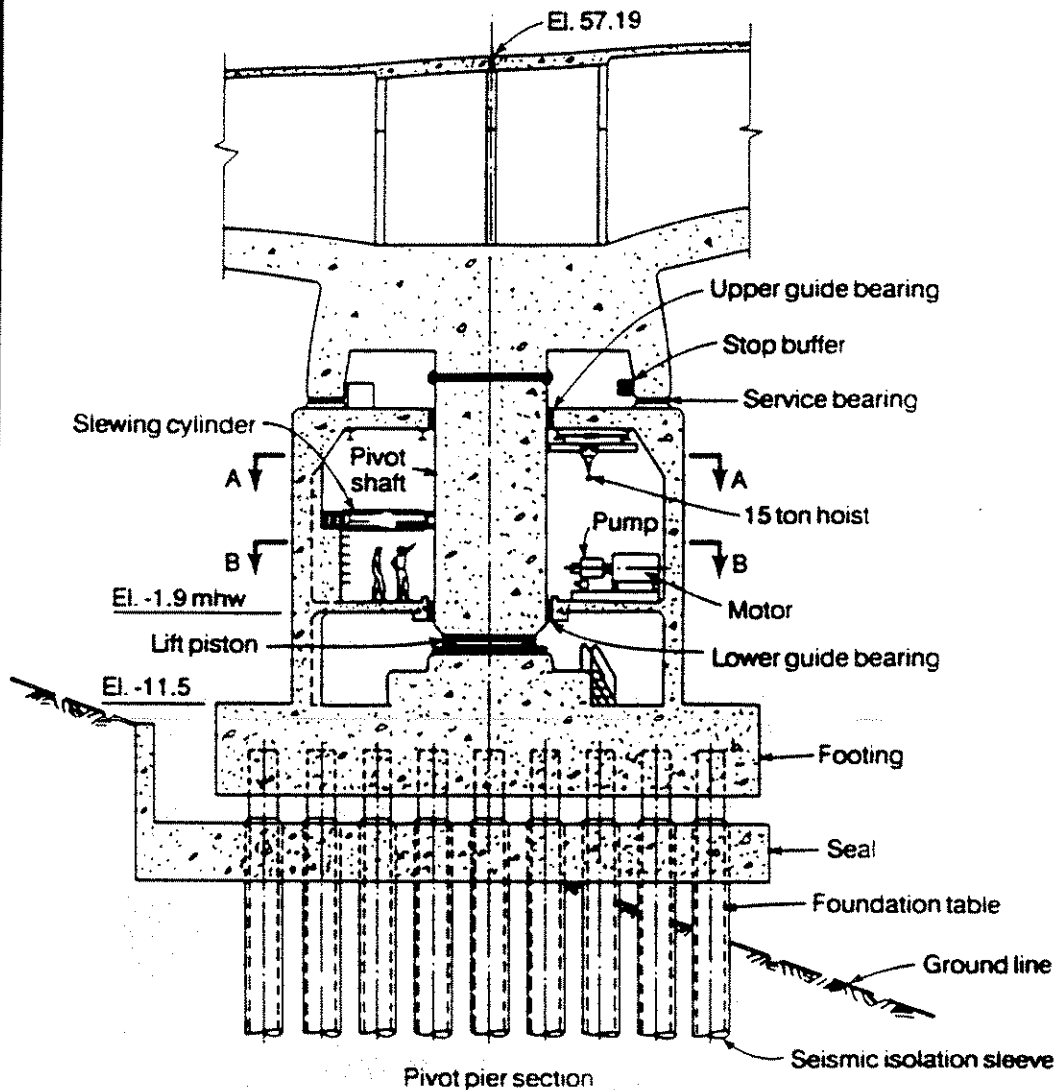

Pivot pier machinery can slew the bridge leaf completely open in 2 min. Design of the pier provides separate load paths for the closed (vehicular traffic) position and for slewing, when the leaf is lifted 1 in. and load transferred to the pivot. Designers were careful to provide access to all machinery for maintenance.

## Application of Engineering Principles

The most notable applications of engineering principles include soil densification, the use of superplasticizers, and segmental concrete construction of the bridge's leaves.

**Densification** - The bridge crosses the Duwamish River near its mouth. The bridge is supported by piles that penetrate soils ranging from hydraulic fill and recent alluvial sands and silts to heavily preconsolidated glacial till. Depth to the till varies from 50 feet on the west to 200 feet on the east. There are lenses of loose silt scattered throughout the alluvium layer, and loose surface silts and the hydraulic fill are subject to liquefaction and potential ground subsidence in a severe earthquake. The engineers specified vibroflotation to densify the problem soils to prevent loss of lateral containment of soil around the upper portion of piles in the event of significant ground motion.

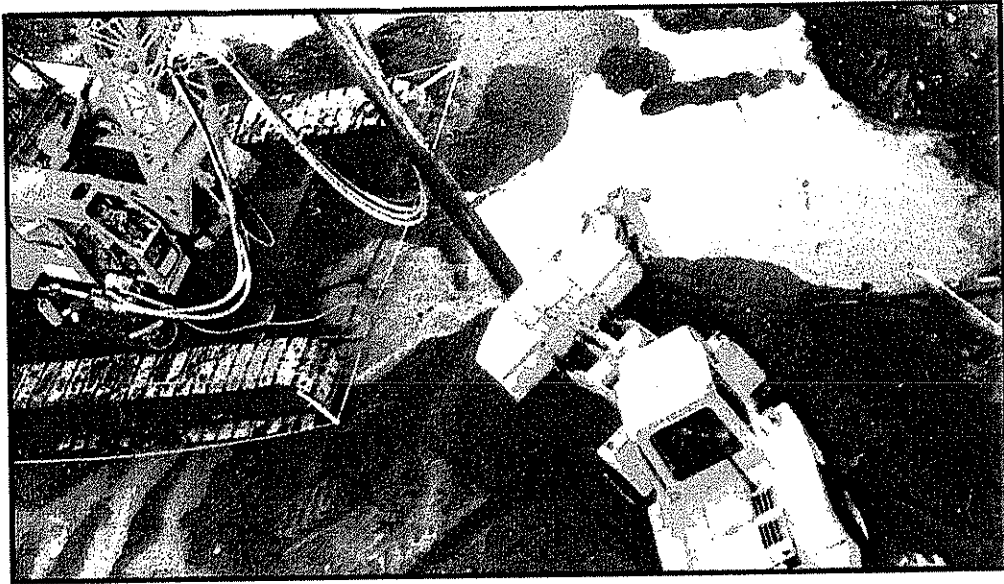

Soil densification prior to substructure work to prevent liquefaction during earthquakes

**Segmental Construction** - Control of long-term deformations was a major concern during design because the concrete box girders, the bridge's leaves, have free ends rather than ends fixed to piers. More post-tensioning was prescribed than is normally required for long-term and short-term deformations. This provided a way to adjust the approach-span

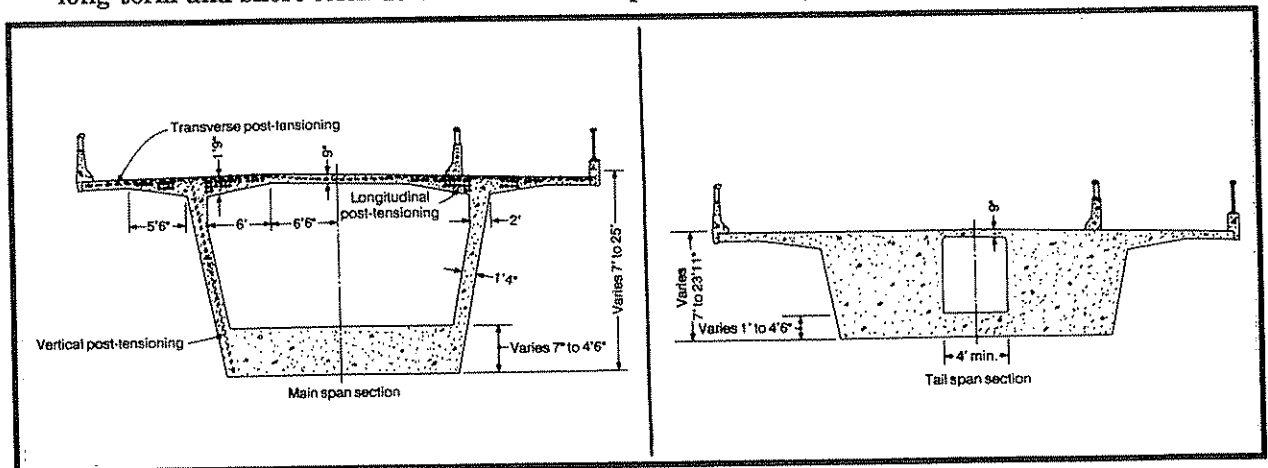

Concrete segments in the main span vary from 7 to 28 ft deep. Additional post-tensioning (not shown in the tail-span section) was installed to prevent long-term deflections. For ballast, the ends of the tail spans are solid except for access cores.

elevation at the tail-span joints, and for adjusting each leaf vertically. Specifications called for simultaneous construction of both leaves. This incremental placement allowed adjustment of the elevation of any successive segment to coincide with its counterpart segment on the opposite pier.

To prevent long-term deformations, design engineers adopted the principle of load balancing for design of the longitudinal post-tensioning. The amount of longitudinal prestressing required to attain 100 percent load balancing for the final dead-load condition required approximately 30 percent more prestressing steel than necessary to satisfy service load stress conditions.

The deck of the box girder was post-tensioned transversely with vertical post-tensioning included in regions of the webs having greater shear requirements. Unbonded tendons were added and can be stressed in the future to account for unanticipated loads.

Balance computations were carried forward to monitor the balance of the structure about each pivot pier in order to make adjustments as necessary to provide a balanced leaf at completion. When the structures were two segments from completion, the leaves were swung shut and checked for elevation and alignment. Minor adjustments were made in the casting of the remaining segments. Final balance adjustments were made with ten foot lengths of galvanized number 18 reinforcing steel placed inside the box girders at the tail spans.

**Superplasticizers** - Modern construction techniques for obtaining high strength concrete with minimum shrinkage and creep were used. Superplasticizers were required to minimize mix water while providing the necessary workability. Water curing was required. Development of concrete strength was monitored by thermocouples embedded in the concrete to permit early prestressing. The results of efforts to control camber were successful with misalignment closure less than 3/4 inch vertically and less than 1/4 inch horizontally.

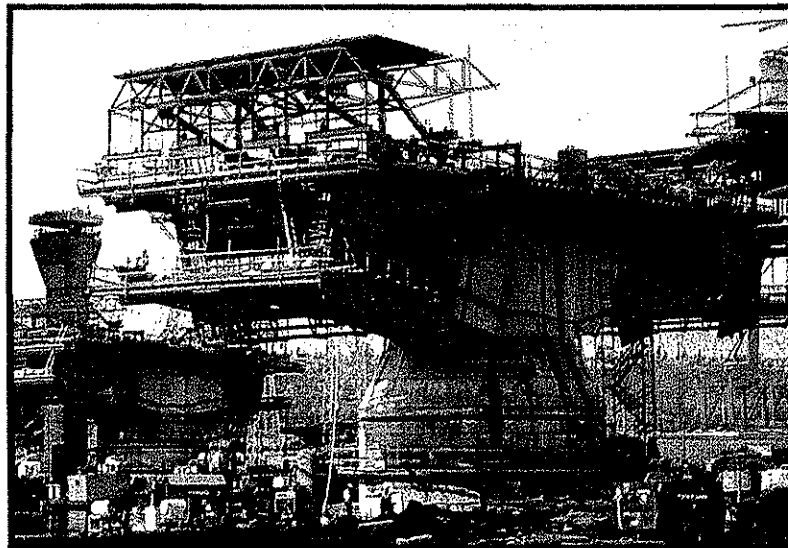

Contractor cast most of the box girders in open position, then closed bridge to check alignment.



## **Importance to Industrial Development**

**Background** - The "Spokane Street" transportation corridor has long served as a principal traffic link in Seattle. It serves West Seattle, a community of over 70,000 and about one-fourth of the City's population. It serves Harbor Island, one of the City's busiest industrial areas. It is a corridor through which over 70,000 vehicles travel daily. About 12,000 of the vehicles are heavy trucks carrying loads back and forth across the Duwamish River. The corridor links West Seattle and Harbor Island with downtown, two major interstate highways and a major state highway used heavily by industrial vehicles that go north and south through the City.

It is as vital a corridor as Seattle has. It is not only the most heavily traveled corridor in the city, but also one of the most heavily used corridors in the state.

This bridge is also a vital artery of the marine industry, which is a major component in Seattle's economy.

**Vehicular Traffic** - The bridge provides an extremely important vehicular transportation arm connecting a network of marine terminals in the port area of Seattle. Linkage of these marine facilities is essential to the economic vitality of the community. The Port of Seattle is one of the most active shipping ports in the nation for container cargo.

The Port of Seattle is in the process of expanding its container operations. Port plans indicate that a majority of Harbor Island will be used for container facilities in the future now that access to the west side of the Duwamish Waterway is secured.

The bridge connects the container terminals on both sides of the waterway with each other and with the rail yards. Clearances on bridge approaches provide area for potential relocation of railroad lines that will assist in development of the container facilities.

Industries, like Boeing further up the Duwamish, have a reliable, modern crossing.

**Marine Traffic Background** - The Duwamish Waterway Improvement Plan prepared by the Seattle District Corps of Engineers prescribed a minimum of 250 feet unobstructed clear distance perpendicular to the waterway between opposing piers. Because the roadway alignment is skewed 45 degrees to the longitudinal axis of the waterway, the span length for a bridge crossing had to be at least 353 feet, an enormous reach for a movable bridge.

The existing 1930-vintage bascule bridge restricted the navigation channel to 150-feet.

The Port of Seattle contributed \$7 million toward construction of this bridge. A primary reason was because the design provided the potential for widening the waterway to the specified 250 feet.

The navigation channel now has the potential for widening and deepening, while it has not changed with the bridge's construction. The bridge as constructed does improve navigation through the waterway. The swing bridge design reduces the chance that it will be struck by a very large ship. The bridge is outside the channel limits when it is in the open position.

Larger ocean going vessels, large freighters, large ships that haul steel and large barges are now better able to navigate the waterway where previously it was more difficult. This is advantageous to the Port of Seattle and their facilities up river at Piers 105 and 115 as well as other industries up river like Boeing.

## Social Significance

**Improved Traffic** - The project includes amenities that make it more beneficial and socially significant. Of course, the obvious benefit of improved transportation access is there. The number of bridge openings, with the new bridge, has been reduced by thirty percent compared to the previous bascule bridge. This means less waiting, less wasting of fuel, and cleaner air. Commuters are happy to have the high level bridge free of the heavy trucks that "chugged" up its steep approaches.

**Bicycle and Pedestrian** - The bridge also provides a much needed pedestrian and bicycle link between West Seattle and the rest of the city. The high-level bridge does not provide this connection. While the new bridge was under construction, a shuttle bus was used to carry bicycles across the Duwamish. The swing bridge has a 12-foot dedicated bicycle/pedestrian lane separated from the traffic lanes. For more serious bicycle commuters, there is a 5-foot shoulder on the roadway.

**River Access** - Part of the bridge design included system of pathways that provide public recreational access to the Duwamish River. These areas will be developed into a park setting. They lead bicyclists and pedestrians to areas next to the water, and bicyclists now have access to West Seattle's very popular beaches and trails.

**Environmental and Recreational** - The project also has environmental benefits. It helps fisheries by providing a fishway near the bridge's main pivot piers that protects small fish that migrate to Puget Sound on their way to the Pacific Ocean. The Duwamish is continuous with the Green River which is used by Indian tribes and the Washington State Department of Fisheries to promote salmon and steelhead as a resource.

**Financial** - The swing bridge also served the public good financially. Studies that compared costs of rehabilitating the previous bascule bridge versus constructing a new swing bridge indicated it was more cost effective in terms of maintenance to invest in a new bridge with a longer life span.

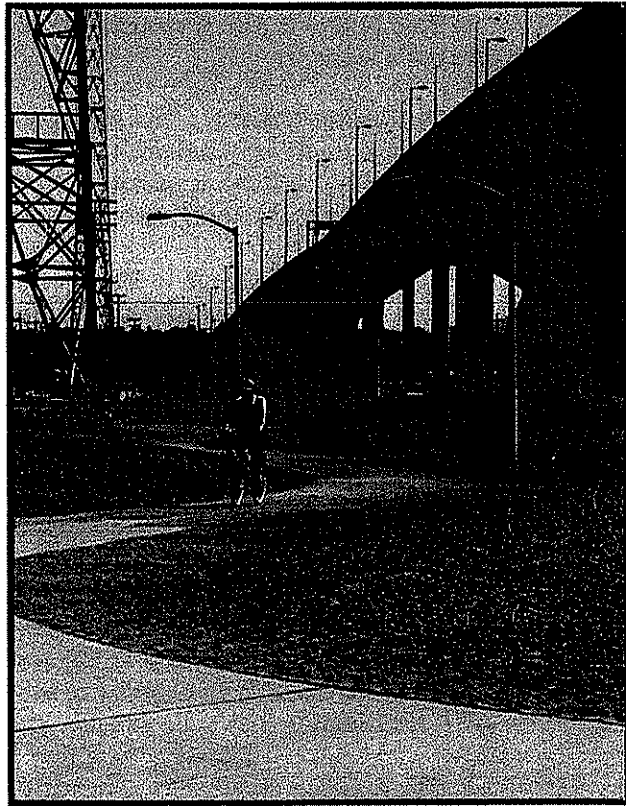

Bicycle/pedestrian surface path on west side of project.

# **West Seattle Low-Level Swing Bridge Facts Sheet**

## **Design Consultant Team:**

**Anderson, Bjornstad, Kane, Jacobs, Inc.  
Parsons, Brinckerhoff, Quade & Douglas, Inc.  
Tudor Engineering**

**The City of Seattle awarded the West Seattle Freeway Bridge Replacement -  
Phase 2, Contract 2, to Kiewit-Global, A Joint Venture in December 1988.**

**Contract Amount: \$33,534,668.65**

**Contract Duration and Schedule: 608 working days (approx. 28 months)**

**Utility work on Harbor Island began March, 1989  
and the bridge opened to traffic in September, 1991.**

## **Project Overview:**

**The West Seattle Low Level Swing Bridge project involved removing the existing bascule bridge and approach structures and replacing them with a double-leaf swing bridge and approach structures on the same alignment.**

**The swing bridge consists of two identical movable leaves supported by pivot piers on each bank of the river.**

**Each leaf includes a 173.5-foot tail span and a 240-foot channel span. The construction was segmental and cast in place then followed by longitudinal and traverse post-tensioning.**

**The bridge provides a 55-foot clearance for vessels. The former bascule bridge provided 43-feet of clearance. The additional 12-feet of clearance resulted in 30 percent fewer openings during the first month of operation.**

**The existing navigation channel width of 150-feet now has the potential for the planned width of 250-feet.**

**The bridge operating machinery is housed in two 42-foot diameter pivot piers. The operating system consists of three hydraulic pump/motor sets in each pivot pier.**

**The pump/motors hydraulically lift each 7,500 ton leaf one-inch (similar to a mechanic's car hoist), then two "slewing" cylinders rotate the leaves 45-degrees to clear the channel in a parallel position.**

**The bridge opening/closing sequence is similar in duration to that of the bascule bridge that was replaced.**

Concrete swing-bridge leaves will open for ships by slewing under a high-level neighbor.

Good luck running out?

# Royer threatens Duwamish bridge veto

## West Seattle bridge deal tentatively agreed upon

A class new toll under a... in Seattle.

I think it's very unfortunate when the port and city can get together on this, (Royer's) suddenly threatening to veto this project.  
— Jeanette Williams city councilwoman

THE SOON-TO-BE-BUILT low-level swing bridge over the Duwamish innovative engineering feat, say officials.

## Cost of low W. Seattle span soars

Latest estimate puts agreement with port on swing bridge in jeopardy

## City may get new money for West Seattle Bridge

# SEATTLE SWING

## Work on new low bridge to start next March

Steel pipe

Low-bridge project hinges on river plan

Officials limit construction hassles

Venerable bridge spanned 59 years

## Innovation paces new swing span

# Hydraulics put new bridge at forefront

New swing bridge  
A concrete swing bridge is being built over the West Duwamish Waterway, connecting Harbor Island and Southwest Seattle.

Unusual bridge taking shape over Duwamish

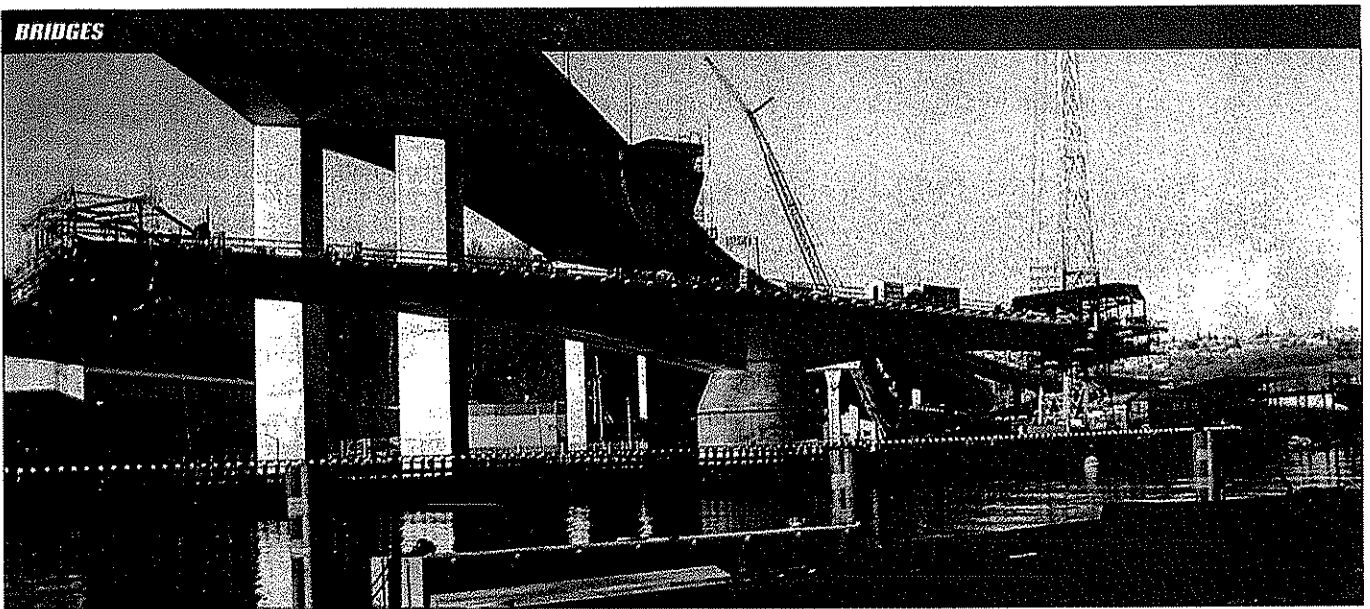

## Seattle slews long, heavy span

*A double-leaf concrete swing bridge spanning 480 ft rises 1 in. and pivots 45°*

**A** new twist, literally, to an old technique enabled engineers to design a swing bridge with leaves longer and heavier than any previous bridge. To open and close the bridge, they developed a hydraulic lifting mechanism to raise the two 418-ft-long concrete leaves 1 in. off their bearings before pivoting them across a shipping channel in Seattle's harbor.

Each leaf has a 240-ft-long main span and a 178-ft tail span that impose a dead load of 7,500 tons on its pivot. No contractors bid on an alternative steel design that weighed 4,850 tons per leaf but was estimated to cost about 9% more. Kiewit-Global, a joint venture of Kiewit Pacific Co., Vancouver, Wash., and Global Consultants/Construction Co., Seattle, won the \$33.5-million contract to build the segmental box girder swing bridge and pre-cast concrete girder approaches.

The new bridge is on the same alignment as the bascule bridge it replaces, and provides a wider

navigation channel in the Duwamish River. It is built in the shadow of a high bridge that carries West Seattle Freeway traffic over Harbor Island.

The alignment and proximity affected the design of the swing bridge. Because the approaches are skewed 45° to the river, the bridge leaves have to pivot only 45° to open. And because the opened bridge positions the high bridge underneath the tail spans had to be short enough to prevent them from hitting the high-bridge piers. So to counterbalance short tail spans with the longer main spans, the designers called for deeper sections in the tail and added ballast.

**Raise or pivot.** The City of Seattle Engineering Dept. engaged the WSB-2 Design Team to evaluate bascule and swing bridge designs for the crossing. The team—comprising Andersen-Bjornstad-Kane-Jacobs Inc. (ABKJ), Seattle, the Seattle office of Parsons Brinckerhoff Quade & Douglas Inc., and Tudor Engineering Co., Seattle—recommended the swing because it would provide greater horizontal clearance and cost less than a bascule design.

John Clark, ABKJ's chief

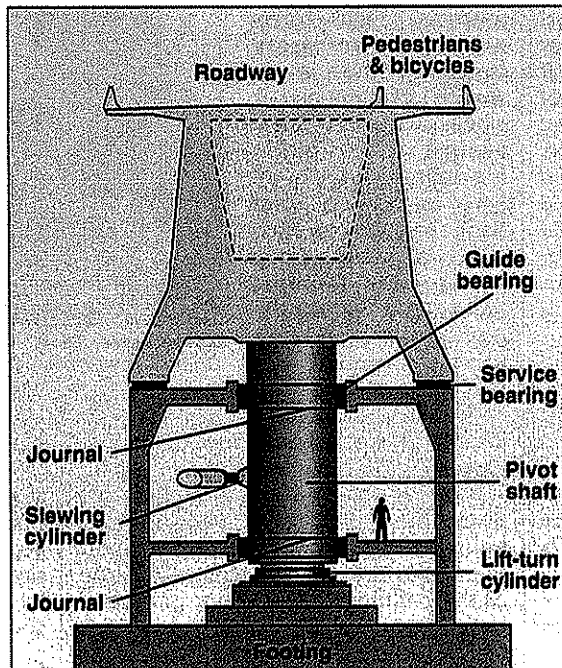

Shaft rises and pivots to turn 7,500-ton bridge leaf.

Concrete swing-bridge leaves will open for ships by slewing under a high-level neighbor.

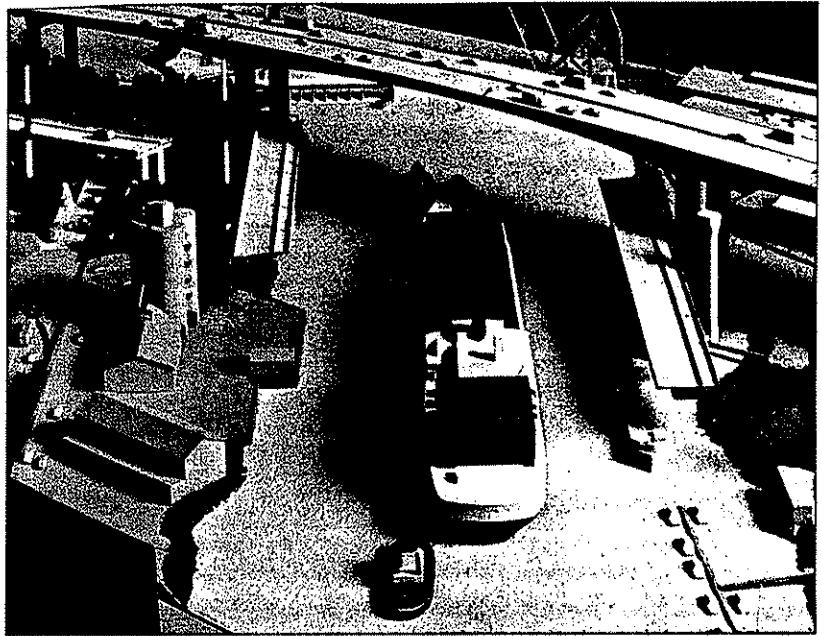

A classic design clothed in new technology is now under construction in Seattle.

**RITA ROBISON**

# SEATTLE SWING

Steel pipe piles, 36 in., ready for driving at Pier 7.



The swing bridge has long been out of favor in the U.S. because of the navigational hazard presented by mid-channel pivot piers. But now a consortium of engineers is updating the design to a state-of-the-art double-leaf concrete segmental structure that will move on equally state-of-the-art machinery to cross Seattle's Duwamish River. The segments, each 12 or 16½ ft long, are currently being cast and counterpoised about identical pivot piers on opposite banks of the river at the rate of one every two weeks.

The Harbor Island Swing Bridge is the latest replacement required by the widening of the ship channel from 150 to 250 ft during the city's massive port improvement project. It connects two parts of the industrial port area that were passed over when an adjacent high-level bridge was constructed to serve the western suburbs. While the 140 ft clearance of the new bridge eliminated the ship

openings required by its bascule predecessor, it was not feasible to construct access ramps from the deck to ground level on both sides of the river to accommodate local traffic to and from Harbor Island.

This local traffic, about 3,500 vehicles per day, was routed over the remaining bascule bridge until its closure for construction of the swing bridge. When the route is reopened in 1991, the local trucks and cars will share Seattle's newest bridge with pedestrians and cyclists, who are excluded from the high-level bridge. According to port authority estimates, the traffic will increase to 11,600 vehicles per day by the year 2000.

The swing bridge was placed on the existing bridge alignment to minimize right-of-way requirements and disruptions to the existing street network. The fact that the axis is skewed 45 deg. to the navigation channel was an important factor in choosing the swing-bridge design, says Thomas A. Kane of Andersen Bjornstad Kane Jacobs, Seattle-based structural engineers and the managing firm of

the joint venture West Seattle Bridge Design Team.

Kane ticks off the also-rans: A vertical lift bridge required towers considerably higher than the adjacent high-level bridge, and this was not permissible because the towers would have stood in the flight approach zone to a nearby airport. A lift bridge was also aesthetically incompatible with the adjacent high-level bridge. The skew distance for the waterway crossing required a 460 ft lift span. The minimum length for a new bascule bridge was 380 ft. However, adjustments in the alignment to achieve this reduced length required additional right-of-way and two reverse curves in the approach structures to reduce the skew from 45 to 30 deg. The original bascule crossed the existing 150 ft wide channel on a 45 deg. skew with a main span of 238 ft.

A major plus for the swing design, Kane explains, is that it is being constructed in the open position, leaving the channel clear for shipping. Although the post-tensioned segmental concrete box girder complements the adjacent high-level concrete box girder, the superstructure was also designed as a steel box girder for bidding. The concrete version was awarded to the low bidder for \$33,537,636, including all approach and site work. No bids were received for the alternative steel design.

The design engineers established the dimensions of each cantilever leaf according to its proximity to the high-level bridge. The bridge has bobtail spans—the leaves could not be made symmetrical about the pivot shaft because of the restricted space available for the tail span to clear the existing bridge pier. The east leaf, with its tail span of 173 ft, just clears the nearest column of the high-level bridge during slewing and, for consistency, the west leaf is the same. The span between the pivot piers is 480 ft from center to center.

On the west, the bridge approach crosses a railroad track and a street; on the east, steep grades determined the approach length. On both sides, stair towers were included for pedestrian access. The control tower, adjacent to but separate from the west pivot pier, is 120 ft above the mean high-water mark, giving the bridge operator

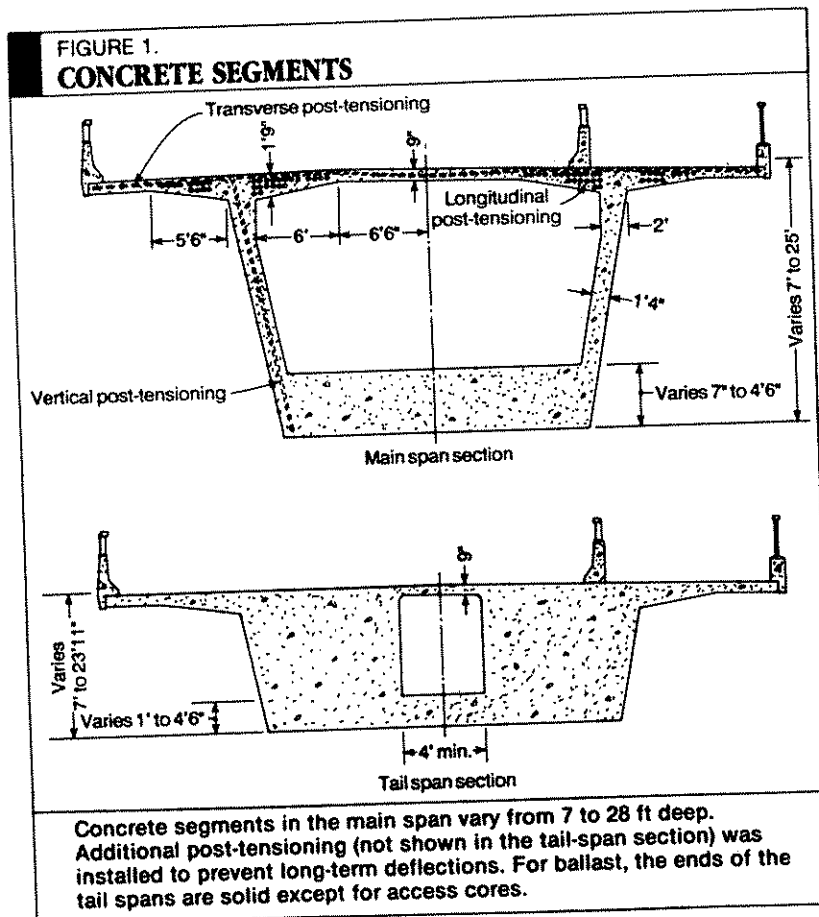

clear views of the channel and the approach roadways.

Seismic design was another consideration, because the area is moderately active, designated UBC Zone III. The bridge crosses the Duwamish River near its mouth, supported by piles that penetrate soils ranging from hydraulic fill and recent alluvial sands and silts to heavily preconsolidated glacial till. Depth to the till varies from 50 ft on the west to 200 ft on the east. There are lenses of loose silt scattered throughout the alluvium layer, and loose surface silts and the hydraulic fill are subject to liquefaction and potential ground subsidence in a severe earthquake. The engineers specified vibroflotation to densify the problem soils to prevent loss of lateral containment of soil around the upper portion of piles in the event of significant ground motion.

Other seismic design details include "seismic isolation sleeves" around the piles on the main piers. Each of the foundation piles is encased in a 48 in. diameter steel pipe sleeve that controls the elevation at which the piles begin to receive lateral support from the surrounding soil.

Kane explains, "The piers are located in the sloping banks of the channel excavation, and the depths of the annular spaces surrounding the piles between the footing and the beginning of the soil-support zone is constant. Without the sleeves, the depth from the footing to the sloping ground surface would vary from 0 to 15 ft. Lateral stiffness of the piles would vary accordingly, causing eccentricity between the center of mass and center of stiffness. In an earthquake, this eccentricity would cause a significant torsional response. The sleeves eliminate the variations and also support the tremie seal, which is separated from the footing."

#### THE CONCRETE BOX

Because the concrete box girders have free ends rather than ends fixed to piers, control of long-term deformations was a major concern during design. Kane says, "For both long-term and short-term deformations, we prescribed more post-tensioning than was required for stress control only. We provided a way to adjust the ap-

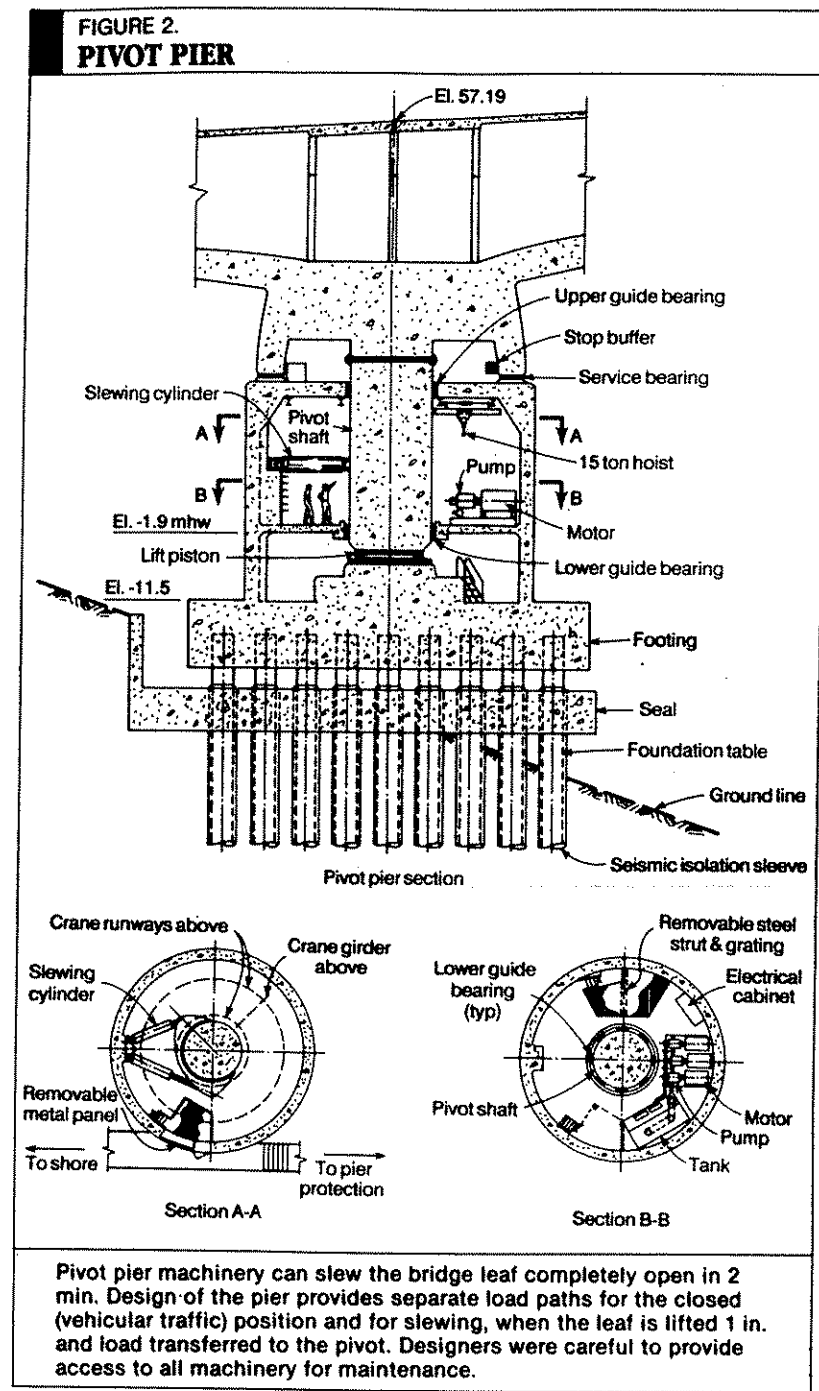

proach-span elevation at the tail-span joints, and for adjusting each entire leaf vertically." He adds that the specifications call for simultaneous construction of both leaves. This incremental placement allows adjustment of the elevation of any successive segment to coincide with its counterpart segment on the opposite pier.

To prevent long-term deformations, the design engineers adopted the principle of load balancing for design of the longitudinal post-tensioning. "The amount of longitudinal prestressing required to attain 100% load balancing for the

final dead-load condition requires approximately 30% more prestressing steel than necessary to satisfy service load stress conditions," Kane says.

The deck of the box girder is post-tensioned transversely and vertical post-tensioning is included in regions of the webs having greater shear requirements. The additional longitudinal post-tensioning reduced the need for vertical post-tensioning in some areas. They added some unbonded tendons that can be stressed in the future to account for unanticipated loads. A 2 in. thick high-density



concrete overlay will provide the final riding surface.

For static balance of each leaf about its pivot pier, the webs of the tail-span segments are thickened on the interior and the last 40 ft of each tail section is solid except for an access shaft 4 ft square. In addition, pockets for precast ballast blocks have been provided for adjustment of the static balance. The specifications also call for field measurement to verify camber behavior after casting of each segment so that the final static balance and vertical alignment of opposing leaves can be closely predicted.

The pier table of each leaf is supported by a transition element that provides two load paths to the foundation. When the bridge is open to vehicular traffic, the load path goes from the superstructure pier table through a conical shell to the walls of the pier house. Service bearings composed of steel plates with reinforced elastomers separate the transition element from the roof of the pier house.

In the operating position, the entire movable leaf, including the transition element and pivot shaft, is raised about 1 in. to transfer the load from the service bearings to the pivot shaft. The load path is from the pier table through the center portion of the transition element to the 12 ft diameter pivot shaft, a concrete-filled steel shell resting on the hydraulically operated lift-turn cylinder. The shaft is kept in the vertical position by guide bearings at the roof and operating floor of the pier house.

To complete both load paths, a reinforced concrete footing is founded on 36 in. diameter concrete-filled steel pipe piles. The 42 ft diameter pier houses that carry the superstructure loads to the foundation are built with 32 in. thick concrete walls. They house the drive machinery, emergency generators and part of the control system.

#### SWING TIME

When ships must pass, a hydraulic slewing cylinder with a 24 in. diameter piston and 92 in. stroke will rotate each movable leaf to the full open position in 2 min. Total elapsed time, including halting vehicular traffic with lights and gates, is 4.5 min. Because the total

weight of each box-girder leaf is suspended on the hydraulic fluid of the lift-turn cylinder, frictional resistance to rotation is limited to the minimal amount from the pivot shaft in contact with the vertical-alignment guide bearings.

In each pier house, two of three 100 hp, 125 gpm hydraulic pumps supply the power to raise and rotate the movable leaf. The designation of the third as a spare is rotated among the three.

Other redundancies built into the system include the ability to move the bridge on only one slewing cylinder or even move it against the friction of the service bearings should the lift-turn cylinder fail to operate. These maneuvers have to be done slowly, and the latter only in an extreme emergency. It requires manual overrides of pressure relief valves in the hydraulic system and would damage some of the service bearings.

Although the design of the locks allows them to be driven against a 1 in. misalignment, the box girder has enough torsional stiffness so that locks are required only at the center line. The midstream and tail locks are driven and pulled by local hydraulic cylinders operated by separate pumps.

Components of the hydraulic system are designed to operate at a normal pressure of 1,700 psi and an emergency pressure of 6,000 psi (the emergency requiring slewing against the service bearing friction). Hydraulic buffers are designed to stop the leaf, when it is moving at full rotation speed of 0.57 deg. per sec, in 0.44 deg. of travel. Open position buffers are located on the roof of the pier house and contact stops on the inner surface of the transition element core. Tail-span buffers are located on the approach-span piers. Because closing speeds are reduced to 35% of normal at the point of contact with the buffers, the buffer loads during normal operation are quite small.

The bridge operator will be provided with a programmable controller that sequences all operations and provides complete status information. The primary position control uses limit switches that initiate braking via the controller. The dynamics of the operating structure—large inertia, low damping—were deemed unsuitable for

dynamic feedback control. The control system is essentially the same as manual operation except that the electronic controller "pushes the buttons," checks interlocks and announces the status on a monitor. The human operator, however, can interrupt most of the steps with manual override.

At the lower level of each pier house, diesel-powered emergency generator sets are rated at 350 kw. The diesel fuel is stored on shore in above-ground enclosed tanks.

One of the most valuable exercises done by the ABKJ engineers during design, according to Kane, was the maintenance access study. "This study ensured that adequate openings were provided for removal and replacement of each piece of machinery, and that each could be reached safely for inspection and maintenance. The study was conducted prior to the final design and set the sizes of openings and details required to replace items such as the hydraulic lift-turn cylinders, which are 9 ft in diameter and weigh approximately 5 tons."

The project was designed by the joint venture West Seattle Bridge Design Team, composed of Andersen Bjornstad Kane Jacobs, Inc., Seattle, and the Seattle offices of Parsons Brinckerhoff Quade & Douglas and Tudor Engineering. Contech Consultants, Seattle, was responsible for the segmental box-girder design. Hamilton Engineering Inc., also of Seattle, designed the hydraulic machinery and Elcon, Portland, Ore., provided electrical design for power and illumination. The Seattle Engineering Department was project sponsor, and Frank Yamagimachi was the city's project engineer.

The construction contract was awarded to Kiewit-Global in September 1988, and notice to proceed was given March 1, 1989. The 22-month schedule calls for completion in January 1991, and at CIVIL ENGINEERING's press time, the project was on schedule. ◊

---

*This article is based on a paper by Thomas A. Kane, CEO, Thomas F. Mahoney, vice president, and John H. Clark, chief bridge engineer, all of Andersen Bjornstad Kane Jacobs, Inc., which was delivered at the annual meeting of the Transportation Research Board in January 1990.*



PROGETTO/DESIGN  
ANDERSON, BJORNSTAD, KANE, JACOBS,  
INC., PARSONS, BRINCKERHOFF, QUADE &  
DOUGLAS, INC., TUDOR ENGINEERING

# IL PONTE GIREVOLE «WEST SEATTLE» NELLO STATO DI WASHINGTON, U.S.A.

PRESENTAZIONE/PRESENTATION  
ING. GIORGIO MONTI

## THE «WEST SEATTLE» SWING BRIDGE IN THE STATE OF WASHINGTON, U.S.A.

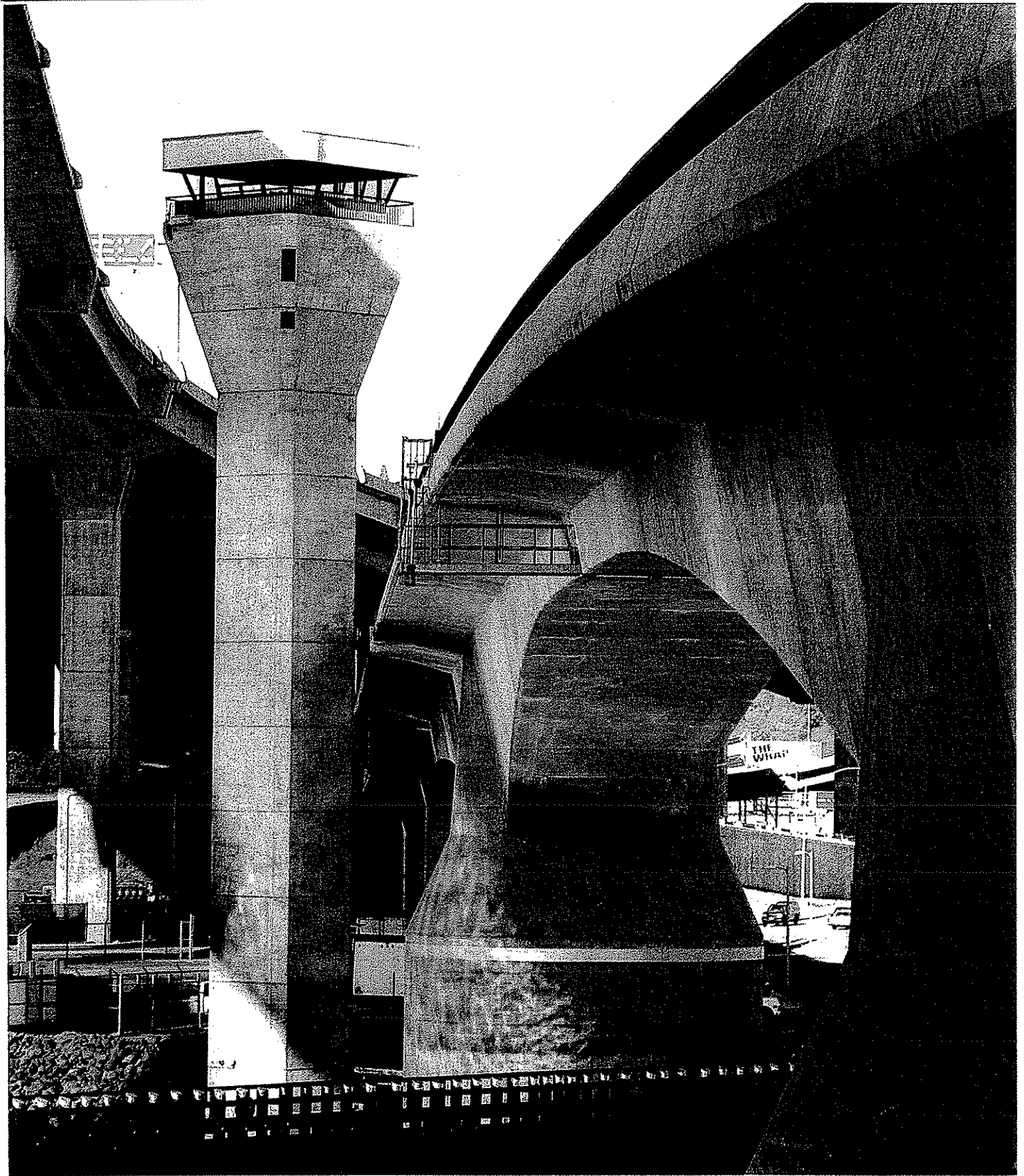



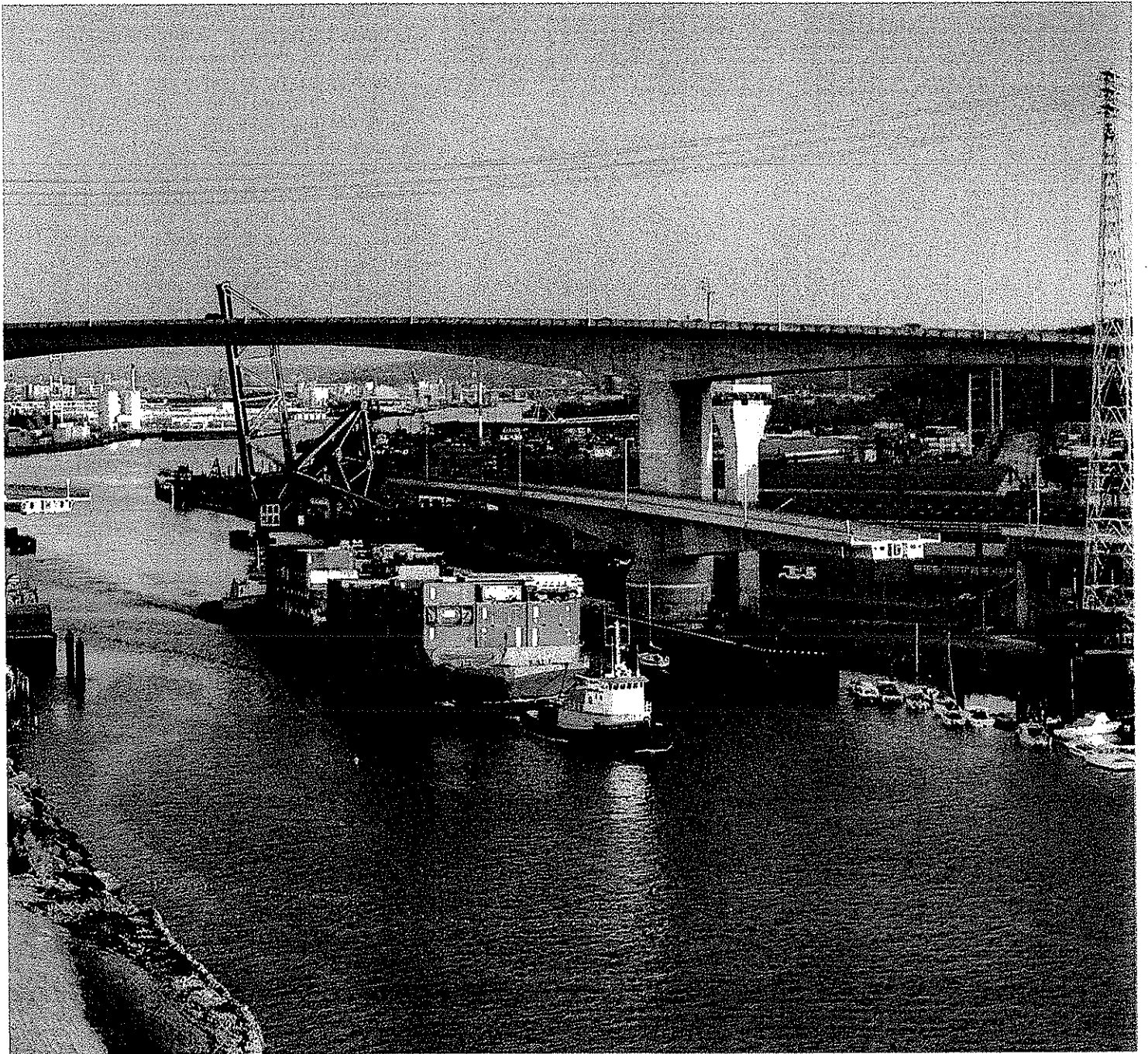

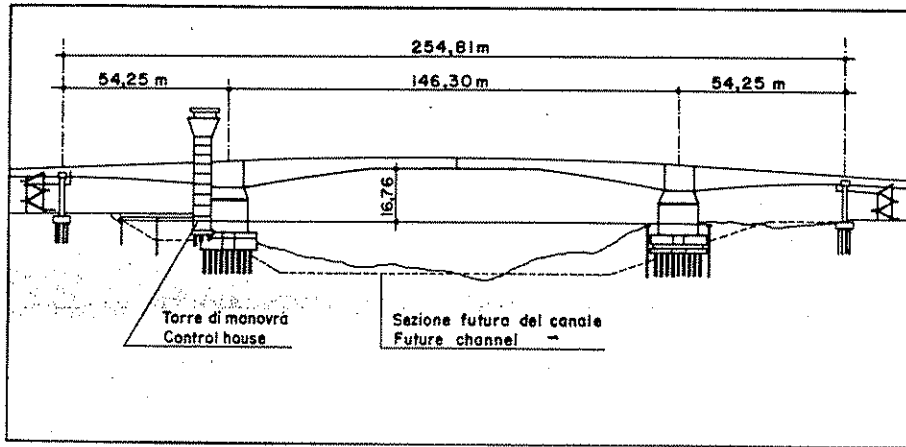

1. Profilo longitudinale del ponte. L'unica campata, suddivisa nei due tronconi girevoli, ha una luce libera totale di 146 m ed un'altezza massima sul livello dell'acqua di 17 m; 2. Sezione schematica di una delle due pile di appoggio (altezza pari a 9,8 m). All'interno della struttura cavo di c.a. (ø 12,8 m) è alloggiato il meccanismo idraulico di sollevamento e rotazione della semi-campata. Il meccanismo rotante è costituito da un cilindro cavo di acciaio (ø 3,66 m) riempito di calcestruzzo.

1. Bridge longitudinal profile. The single span, made up of two swinging segments, has a 146 m total clear span and a maximum height above water level of 17 m; 2. Schematic section of one of the two support piers (9.8 m tall). Inside its hollow r.c. structure (diam. 12.8 m) is the hydraulic mechanism for lifting and rotating the semispans. The rotating mechanism depends upon a concrete-filled hollow steel cylinder (diam. 3.66 m).

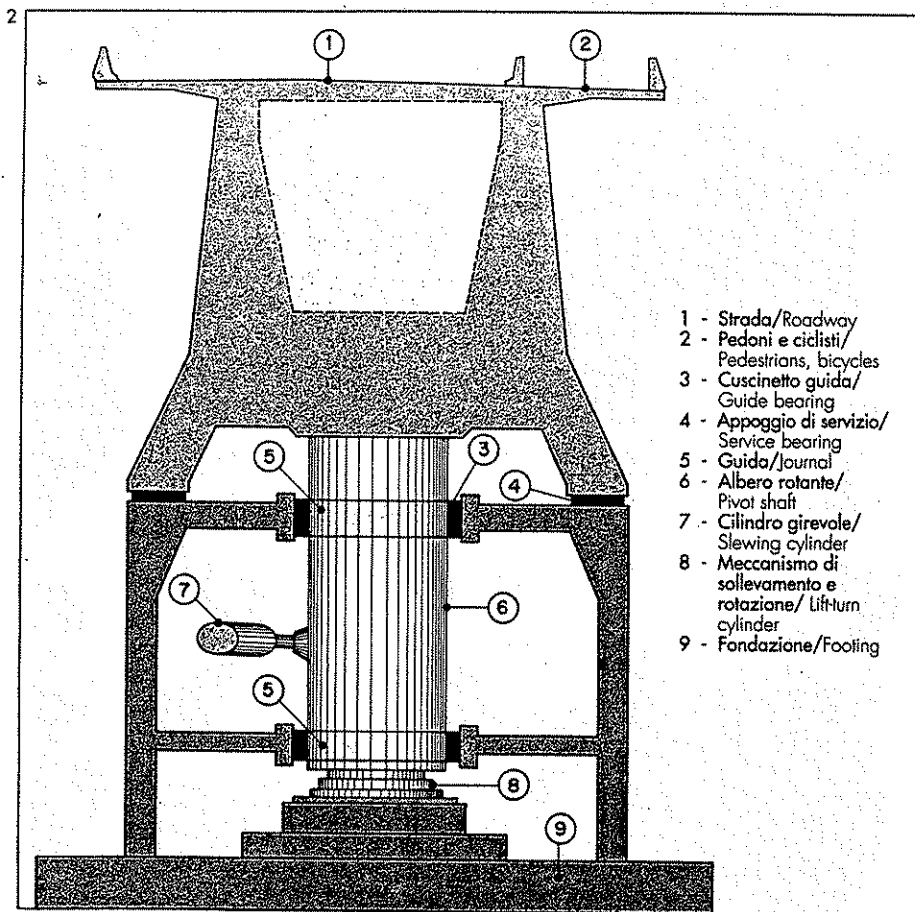

- 1 - Strada/Roadway
- 2 - Pedoni e ciclisti/ Pedestrians, bicycles
- 3 - Cuscinetto guida/ Guide bearing
- 4 - Appoggio di servizio/ Service bearing
- 5 - Guida/Journal
- 6 - Albero rotante/ Pivot shaft
- 7 - Cilindro girevole/ Slew cylinder
- 8 - Meccanismo di sollevamento e rotazione/ Lift-turn cylinder
- 9 - Fondazione/Footing

di altezza sul livello di piena del canale, obbligava a più di 10 aperture giornaliere per consentire il passaggio dei natanti, creando, nelle ore di punta, situazioni di congestione con ripercussioni fin sulla Spokane Street, nonostante l'attuazione di qualche iniziativa volta a deviare sul viadotto sovrastante il traffico veicolare privato diretto alle aree residenziali.

La situazione, già difficoltosa, fu resa ancor più critica quando, nel 1979, un cargo che entrava nel canale urtò una pila del ponte, rendendo inutilizzabile una campata basculante e restringendo ulteriormente l'accesso al porto, con sensibile pericolo per la navigazione e conseguente allungamento dei tempi di transito.

Poiché il viadotto sovrastante non poteva essere impiegato per i collegamenti locali fra le due aree industriali, per la difficoltà di realizzare adeguate rampe di accesso fino alla quota di 43 m sul livello del canale, sul finire degli anni ottanta si decise per la sostituzione del vecchio ponte.

I progettisti, in un clima economico non certamente favorevole a causa dei drastici tagli apportati ai fondi federali in quel periodo, si trovarono di fronte ad un problema apparentemente di ardua soluzione: il dover attraversare un canale navigabile, di ampiezza notevole, con un ponte che non costituisse pericolo per la navigazione e che fosse economicamente conveniente. Il tutto, andando incontro alla ulteriore richiesta delle autorità preposte al coordinamento del porto, di prevedere la possibilità di ampliare la portata del canale da 46 m a 76 m, per agevolare il passaggio dei grandi natanti transoceanici.

Nella fase preliminare di studio di fattibilità furono esaminate ben 19 possibili posizioni del nuovo ponte in relazione al viadotto più alto esistente. Inoltre, furono verificate economicamente tre differenti tipologie strutturali per il ponte: a sollevamento verticale, basculante e girevole. Il primo fu scartato in quanto si ritenne incompatibile dal punto di vista estetico col viadotto esistente, dato che le torri l'avrebbero sovrastato in altezza, creando un contrasto esteticamente sgradevole. La seconda opzione venne rapidamente accantonata a causa della notevole ampiezza delle campate, che avrebbe comportato l'adozione di impianti di sollevamento di notevole potenza. Per ridurre la luce della campata, si sarebbe potuta diminuire l'inclinazione dell'asse del ponte da 45° a 30°, ma questo avrebbe richiesto il completo rifacimento della rete stradale di accesso ad entrambi i ponti.

La soluzione del ponte in c.a.p. a doppia campata girevole, con pile ruotanti su

ogni lato del canale, risultò come la più soddisfacente, non solo perché prevedeva costi inferiori del 10% rispetto ad una soluzione analoga in acciaio, che pure aveva un peso totale sensibilmente inferiore, ma anche perché consentiva di ottenere una campata di luce maggiore rispetto alla classica soluzione del ponte ad unica campata girevole. Questa soluzione era infatti stata accantonata per l'intralcio alla navigazione costituito dalla presenza di una pila centrale. Peraltro con l'adozione di due pile girevoli sulle opposte rive del canale, il rischio di collisione di un natante contro una pila è ridotto al minimo, poiché la sagoma del ponte, in posizione aperta, risulta interamente esterna al canale.

Questa caratteristica ha avuto altresì effetti determinanti sui costi di realizzazione: con due campate girevoli indipendenti, ruotanti su due pile disposte ai lati del canale, tutto il processo costruttivo si è potuto eseguire a ponte aperto, semplificando l'organizzazione del cantiere e consentendo la navigabilità della via d'acqua anche durante il periodo di costruzione.

Anche il fattore estetico ha avuto un sensibile peso nella scelta della soluzione finale. Si è infatti riconosciuta la maggior armonia con cui la curva dell'impalcato in c.a.p. si inserisce in quella del viadotto sovrastante, anch'esso in c.a.p., e anzi si trova a far da raccordo visivo con questo, creando un insieme omogeneo di forme e materiali.

#### DESCRIZIONE DELL'OPERA

Il ponte rappresenta un record nel suo genere: è infatti il primo ponte al mondo a doppia campata girevole interamente controllato idraulicamente ed è al tempo stesso il più pesante, con le due campate del peso di 7500 t ciascuna.

Il progetto prevedeva il mantenimento dell'inclinazione a 45° dell'asse del ponte rispetto all'asse del canale, sia per conservare l'allineamento con il viadotto più elevato già esistente, sia soprattutto per minimizzare i lavori di riorganizzazione della rete stradale, sfruttando quella esistente di accesso ai due ponti. Scelto l'allineamento, le luci delle campate girevoli sono state determinate in maniera da evitare, nel corso della rotazione delle stesse, la collisione contro le pile del viadotto adiacente. La luce libera totale, da asse ad asse delle pile, è stata così determinata in 146 m, fissando la luce delle due campate principali sul canale a 73 m. La luce delle campate di coda, dalla parte opposta del canale, è stata determinata pari a 53 m, sulla base di considerazioni analoghe. Le due parti del

*This situation, already difficult, became critical when in 1979 a freighter entering the channel struck a bridge pier, making one bascule span unuseable and thus further constricting access to the port, with sensible danger to sailing and consequent lengthening of transit times.*

*Since the overlying viaduct could not be used for local connections between the two industrial areas, owing to the formidable difficulties in the way of creating suitable access ramps up to a level of 43 m above channel level, at the end of the eighties it was decided to replace the old bridge.*

*The economic climate not being favorable owing to the drastic cuts being made in federal funding during that period, design found itself faced by a problem of arduous solution: the need to cross a navigable channel of considerable width on a bridge that posed no danger to navigation and that was still economical. And all this with the further demand by the port authorities that provision be made for the possibility of widening the channel from 46 m to 76 m, in order to facilitate the passage of large ocean-going steamers.*

*During the preliminary feasibility-study phase, no fewer than nineteen possible positions for the new bridge in relation to the higher already-existing viaduct were considered. Furthermore, three different structural typologies for the bridge were considered: vertical-lift bridge, bascule bridge and swing bridge. The first was discarded since deemed incompatible esthetically with the existing high viaduct, for the towers would be taller than it, creating an esthetically displeasing contrast. The second too was rapidly set aside, owing to its long span length, which would have demanded the adoption of extremely powerful lifting systems. Its span length could have been reduced by lowering the skew of the bridge centerline from 45° to 30°, but this would have required the whole redoing of the roadway system accessing both bridges.*

*The solution of a prestressed-concrete bridge having a dual swing span, with rotating piers on each side of the channel, appeared then to be the most satisfactory, not just because it would cost 10% less than a similar steel bridge, even though this would be sensibly lower in weight, but also because it made possible a span of longer length relative to the classical solution of the bridge having but one swing span. This solution had in fact been discarded owing to the obstacle presented to sailing formed by the presence of a center pier. However, with the adoption of two rotating piers on opposite sides of the channel, the danger of a ship's colliding against a pier was greatly reduced, since the bridge profile, in open position, was wholly outside the channel.*

*This characteristic also affected construction costs: with two independent swing spans rotating on two piers set at the channel sides, the whole construction process could be carried out with the bridge open, simplifying the construction yard organization and permitting sailing along the waterway all through construction.*

*Esthetics too exerted an influence on the choice of final solution. The greater harmony with which the curve of the prestressed-concrete deck blends with that of the overlying viaduct (of prestressed concrete too) was acknowledged, and in fact the two are in visual connection, a homogeneous whole of forms and materials being thus created.*

#### DESCRIPTION OF THE STRUCTURE

*The bridge has set a record for its kind: it is in fact the first bridge in the world having a dual swing span that is entirely hydraulically controlled and is at the same time the heaviest, with its two spans weighing 7500 tons each.*

*The design maintained the 45° skew of the bridge centerline with the channel centerline, both to conserve the alignment with the already-existing higher viaduct, and most especially to minimize the work of reorganizing the street system, exploiting the already existing access system for the two bridges. With the alignment chosen, the lengths of the swing spans were determined, in such fashion as to avoid, during their rotation, collision against the piers of the adjacent viaduct. The total span, from pier center to pier center, was thus set at 146 m, the length of the two main spans over the channel being set at 73 m. The length of the tail span on the opposite side of the channel was set at 53 m, on the basis of similar considerations. The two parts of the swing bridge, independent the one of the other, are thus two asymmetric tees, with different-length cantilevers, which in closed position are connected together and with the access ramps by hydraulic hook on devices positioned on the crown and tail deck sections.*

*The 9.8 m-high piers are of r.c. and have a hollow circular section of diameter 12.8 m with a 0.81 m wall thickness. Their interior houses the machinery used to lift and rotate the deck.*

*The piers bear on pile foundations, with piles driven down to 18 m; their top 12.5 m is sheathed with steel pipe, for aseismic protection as will be described further on below.*

*On both bridge fronts there are pedestrian access stairs. Nearby the west pier a control tower was set, it holding the electronic and manual controls for the bridge closing and*

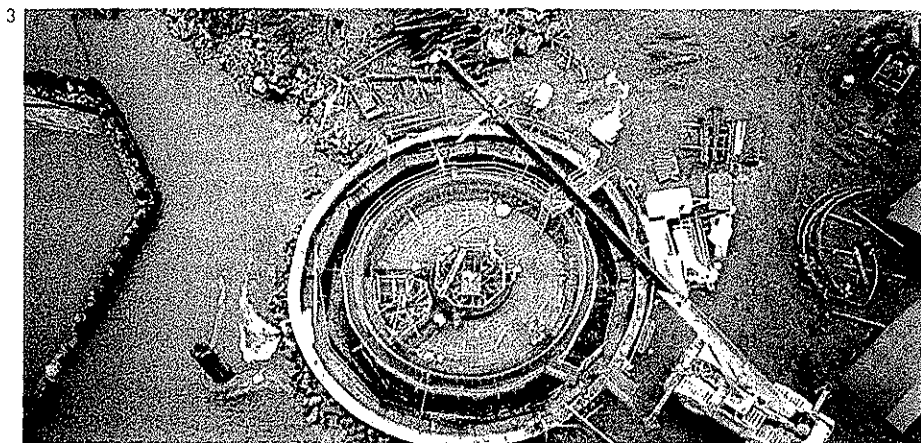

3. La fondazione è costituita da una palificata (h= 18 m) progettata e realizzata per sopportare una moderata attività sismica; 4. Realizzazione della pila: le pareti della struttura hanno uno spessore di 0,81 m; 5-6. Le pile, elemento caratterizzante l'opera, costituite da una parte inferiore di sezione cilindrica ed una superiore di forma tronco conico, sono state realizzate interamente con getto in opera del calcestruzzo; 7. Allestimento della cassaforma per il getto della soletta inferiore della piastra di transizione per il trasferimento dei carichi tra i due elementi di forma tronco conica e cilindrica componenti la pila; 8. Assemblaggio dell'armatura prima del getto della parte tronco conico superiore della pila cui è affidato il compito, a ponte «chiuso» di trasferire il carico verticale direttamente alla pila cilindrica sottostante.

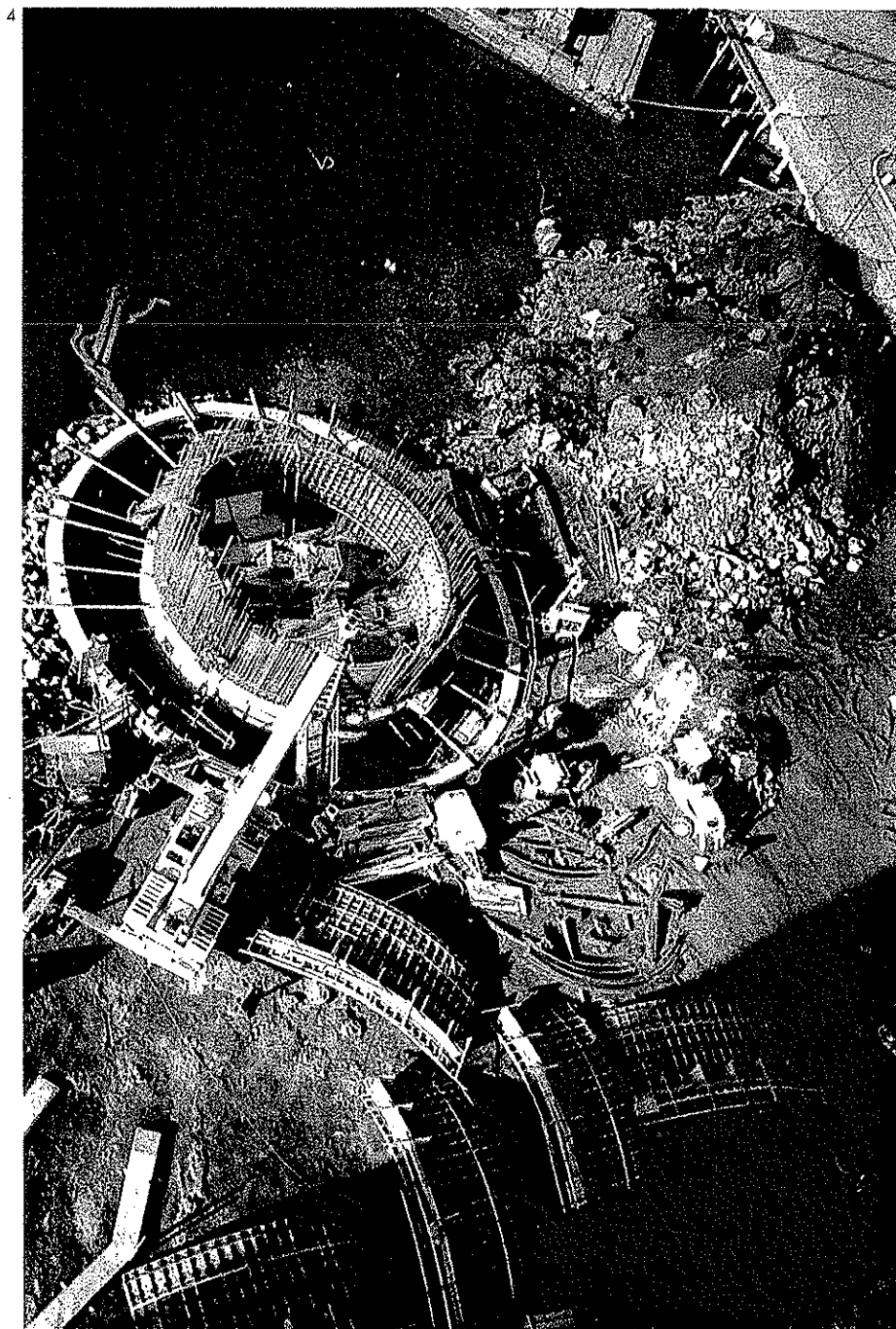

Le pile, di 9,8 m di altezza, sono in c.a. ed hanno sezione circolare cava di diametro pari a 12,8 m e pareti di spessore di 0,81 m e al loro interno sono alloggiati i macchinari adibiti al sollevamento e alla rotazione dell'impalcato.

Le fondazioni delle pile sono su pali, infissi fino a una profondità di 18 m e incapsulati nei 12,5 m superiori in tubi di acciaio che hanno scopo di protezione antisismica, secondo le modalità che verranno descritte nel prosieguo.

Su entrambi i fronti del ponte sono previste scale di accesso per i pedoni. In prossimità della pila ovest è stata posizionata una torre di controllo che ospita i dispositivi per il controllo elettronico e manuale delle operazioni di chiusura e apertura del ponte, nonché la cabina dell'operatore che dall'altezza di 36 m ha una visione completa del canale e delle strade di accesso.

Il franco sul livello del canale è stato innalzato a 17 m, il che ha consentito di ridurre del 30% il numero di aperture giornaliere, con notevole alleggerimento del traffico nelle rampe di approccio al ponte e nelle zone circostanti all'interno dell'area portuale che ha di fatto eliminato qualsiasi ripercussione sul traffico della Spokane Street. Ogni ciclo di apertura del ponte, ad una velocità angolare costante di 0,57 gradi al secondo, dura in media due minuti, che divengono 4,5 comprendendo l'accensione dei semafori e l'abbassamento delle barriere per il blocco del flusso veicolare sul ponte.

Il traffico locale, prima dell'entrata in servizio del nuovo ponte, era stato valutato pari a 3500 veicoli al giorno, di cui il



3. The foundations are pile foundations (18 m deep) designed and built to withstand a moderate earthquake; 4. Construction of the pier: its walls are 0.81 m thick; 5-6. The piers are the members that characterize the structure. They comprise a lower part of cylindrical cross section and an upper part of truncated-conical form. They were built entirely of in situ-poured concrete; 7. Preparing the forms for the pour of the lower slab of the transition plate for the transfer of the loads between the two elements, of truncated-conical form and cylindrical form, composing the pier; 8. Assembly of the reinforcements before the pour of the upper truncated-conical part of the pier, which is assigned the task, when the bridge is "closed", of transferring the vertical load directly to the cylindrical pier below.

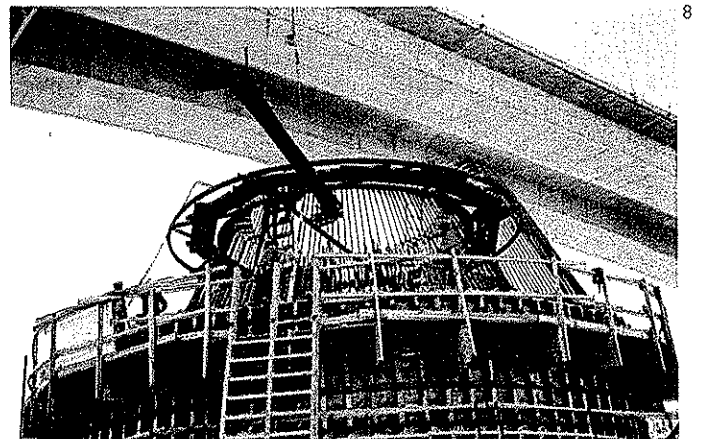
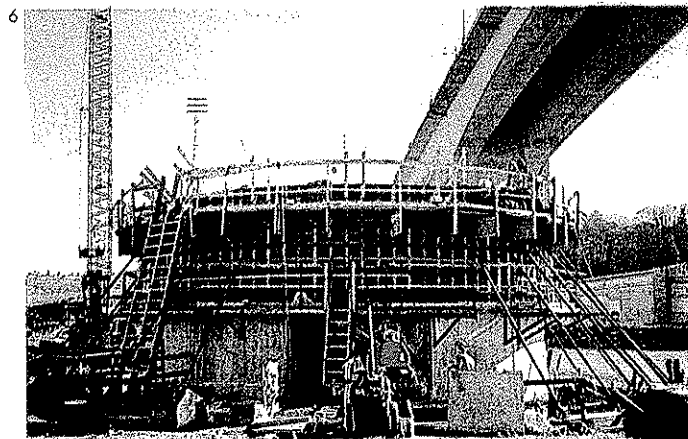
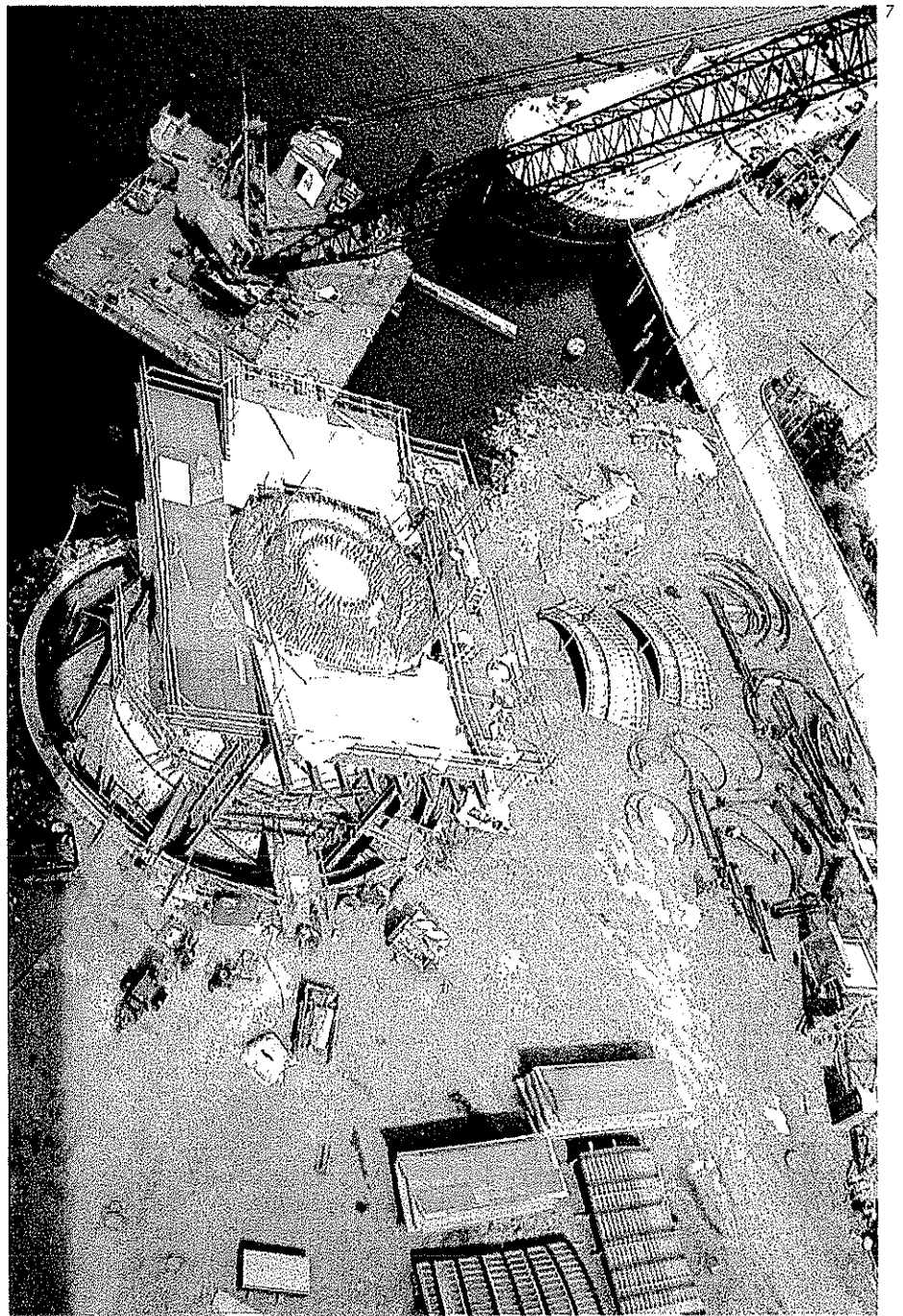
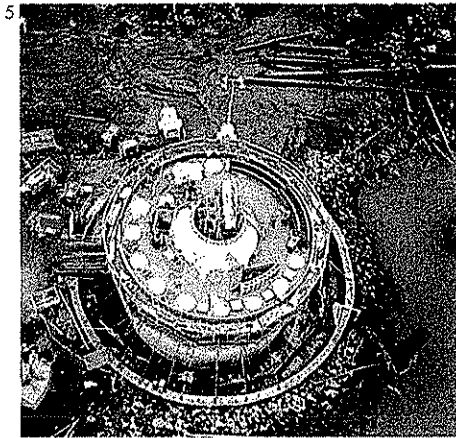

15% costituito da mezzi pesanti, mentre ora si prevede per il 2000 un incremento progressivo degli attraversamenti fino a soddisfare con un adeguato livello di servizio a regime un traffico di circa 11600 veicoli al giorno.

## CARATTERISTICHE STRUTTURALI

### L'IMPALCATO

L'impalcato è costituito da un cassone in c.a.p. a sezione variabile. L'altezza del cassone nella campata principale varia da un minimo di 2,1 m in corrispondenza del punto di aggancio in chiave con l'altra campata, a un massimo di 7,6 m sopra la pila. L'altezza del cassone nella campata di coda varia da 7,0 m sulla pila a 2,1 m nel punto di aggancio in coda con la rampa di accesso. La larghezza dell'impalcato (15,2 m) consente l'inserimento di due corsie per il traffico veicolare e di una pista ciclabile o pedonale di 3,5 m.

La quantità di armatura di precompressione longitudinale è stata dettata, più che dal rispetto dello stato tensionale delle sezioni, dalla necessità di controllare lo stato di deformazione dell'impalcato e, in particolare, la freccia in chiave. Questa ovviamente, al termine della costruzione, doveva risultare perfettamente identica nelle due campate girevoli per permettere l'operazione di aggancio e la perfetta richiusura del ponte. A questo fine, si è reso necessario prevedere la presenza di cavi longitudinali aggiuntivi per ridurre le deflessioni dovute ai carichi permanenti, per cui la quantità di armatura di precompressione è risultata superiore del 30% a quella strettamente necessaria ad imporre lo stato tensionale desiderato alle sezioni. Inoltre, per far fronte alle deformazioni dovute a carichi inattesi, sono stati previsti degli alloggiamenti all'interno dell'impalcato per l'eventuale futuro inserimento di altri cavi.

L'allineamento, sia verticale che orizzontale, delle due campate veniva controllato costantemente nel corso della costruzione, chiudendo il ponte periodicamente. Al posizionamento dei due conci di chiave, il massimo sfasamento verticale fra le due campate è risultato di circa 15 mm, cioè ampiamente all'interno delle tolleranze stabilite dai meccanismi di aggancio.

La soletta superiore dell'impalcato a cassone è precompressa anche in direzione trasversale, mentre le pareti verticali sono soggette a precompressione verticale, anche se in alcune parti dell'impalcato l'elevata precompressione longitudinale ha

consentito di ridurre questo tipo di interventi.

### LE PILE GIREVOLI

Le pile, di altezza pari a 9,8 m, sono come già segnalato a sezione circolare cava, di diametro esterno pari a 12,8 m e con pareti di 0,81 m di spessore, ed oltre alla ovvia funzione di sostenere l'impalcato fungono anche da alloggiamento di un albero ruotante adibito al sollevamento e alla rotazione dell'impalcato stesso, nonché dei generatori di emergenza e di parte del sistema di controllo.

I carichi verticali provenienti dall'impalcato sono trasferiti in fondazione attraverso due percorsi alternativi, selezionati da un elemento di transizione in c.a. di forma troncoconica. Questo elemento, in condizione di ponte chiuso, e cioè a servizio del traffico veicolare, trasferisce il carico verticale direttamente alla pila mediante piastre metalliche elastomerizzate, disposte su un cerchio di diametro pari a 11,4 m. Quando si vuol consentire il transito dei natanti, l'apertura del ponte viene effettuata in due fasi: l'albero ruotante presente al centro esercita una spinta di sollevamento sul nucleo centrale dell'elemento di transizione, sollevando l'impalcato sovrastante di circa 25 mm; successivamente due martinetti idraulici agiscono su di un eccentrico collegato all'albero ruotante, esercitando il momento necessario a far ruotare l'impalcato.

In questa fase l'impalcato poggia direttamente sull'albero ruotante, costituito da un tubo metallico di diametro 3,66 m con pareti di 44 mm di spessore, riempito di calcestruzzo. La base di questo, a sua volta, poggia sul cilindro del martinetto idraulico che esercita il sollevamento. Un aspetto curioso è che il diametro del martinetto, pari a 3,66 m, sul quale si è dimensionato tutto l'albero ruotante, è stato essenzialmente dettato dalla dimensione della più grande guarnizione disponibile sul mercato.

La verticalità dell'albero ruotante durante le operazioni di rotazione, è assicurata da due guide disposte in prossimità della base e della sommità dell'albero stesso. Nel corso del movimento rotatorio del ponte, queste guide rappresentano l'unica, peraltro trascurabile, sorgente di attrito dato che alla base l'albero ruotante può sostanzialmente considerarsi come galleggiante sul fluido del martinetto di sollevamento. La scelta di ottenere una struttura galleggiante è stata obbligata dal peso dell'impalcato. Generalmente, nei ponti girevoli la rotazione avviene intorno ad un supporto centrale, ma in questo caso l'elevato peso delle campate avrebbe richiesto il ri-

opening operations, as well as the cabin for the operator, who, from a height of 36 m, has a complete view of the channel and of the access roads.

The clearance above channel level was raised to 17 m, which means a 30% reduction in the number of daily openings, and thus a considerable thinning out of the traffic on the bridge approach ramps and in the neighbourhood of the port area, so that the ill effects on Spokane street traffic have been virtually eliminated. Each bridge opening cycle, which takes place at a constant angular speed of 0.57 degrees per second, lasts an average of two minutes, which become 4.5 minutes when the lighting of the signals and the lowering of the barriers blocking the flow of traffic over the bridge are taken into consideration.

Before the new bridge went into service the local traffic was estimated at 3,500 vehicles per day, of which 15% comprised heavy vehicles, while now the forecast for the year 2000 is a progressive increase in transits until at full operation a traffic of some 11,500 vehicles per day can be handled, with a proper level of service.

## STRUCTURAL CHARACTERISTICS

### THE DECK

The deck is a prestressed-concrete box girder of variable cross section. The box depth in the main span varies from a minimum 2.1 m at the crown where the two decks meet, to a maximum 7.0 m above the pier, to 2.1 m again at the tail, where it hooks onto the access ramp. The deck width (15.2 m) provides room enough for two vehicle-traffic lanes and for a bicycle or pedestrian path 3.5 m wide.

The amount of longitudinal prestressing reinforcing was dictated not so much by the stress states in the section as by the need to control the strain in the deck and, in particular, the deflection at the crown. At the end of construction this of course had to be perfectly identical for both swing spans in order to permit the hooking-on operation and the perfect reclosure of the bridge. To this purpose, it was necessary to provide for additional longitudinal cables to reduce the deflections due to permanent loads, for which the amount of prestressing reinforcing was 30% greater than that strictly necessary to obtain the desired stress state in the sections. Furthermore, to deal with the strains due to unplanned-on loads, housings were placed within the deck for the future insertion of more cables.

The alignment, in both line and grade, of

» » » 9. Cassaforma per il getto dell'elemento di testa pila da cui si procederà con la costruzione dell'impalcato; 10-11. L'altezza del cassone di impalcato in corrispondenza della pila, è pari a 7,6 m. La sezione cava consente le operazioni di ispezione e manutenzione; 12. L'assemblaggio progressivo dei conci di impalcato (larghezza pari a 15,2 m) ha richiesto particolari cautele dal punto di vista statico per la differente lunghezza dei due sbalzi costituenti la stampella di ogni semi-campata.

» » » 9. Form for the pour of the pierhead element, from which the construction of the deck will go ahead; 10-11. The depth of the box-girder deck at the pier is 7.6 m. Its hollow section permits inspection and maintenance operations; 12. The progressive assembly of the deck segments (15.2 m wide) demanded special precautions from the statics stand-point, owing to the different lengths of the two cantilevers forming the tee of each semispan.

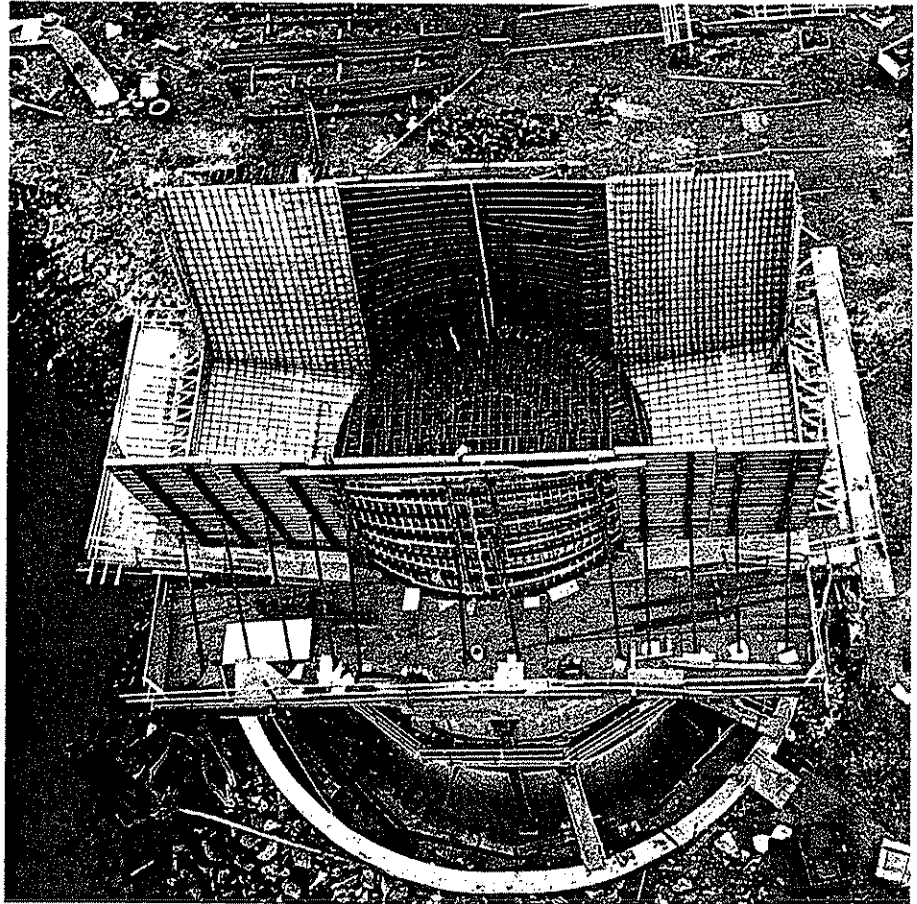

10



11

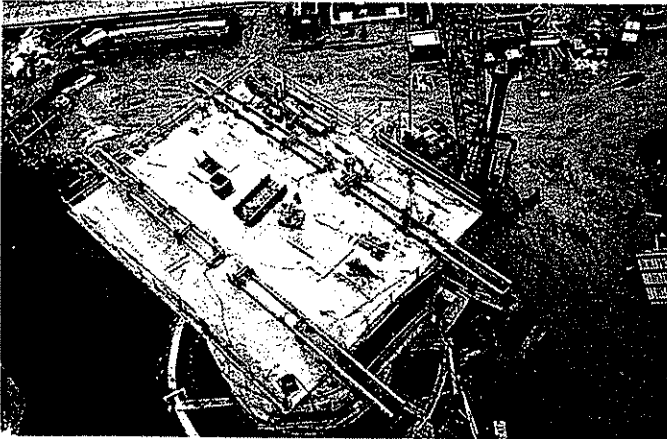

12

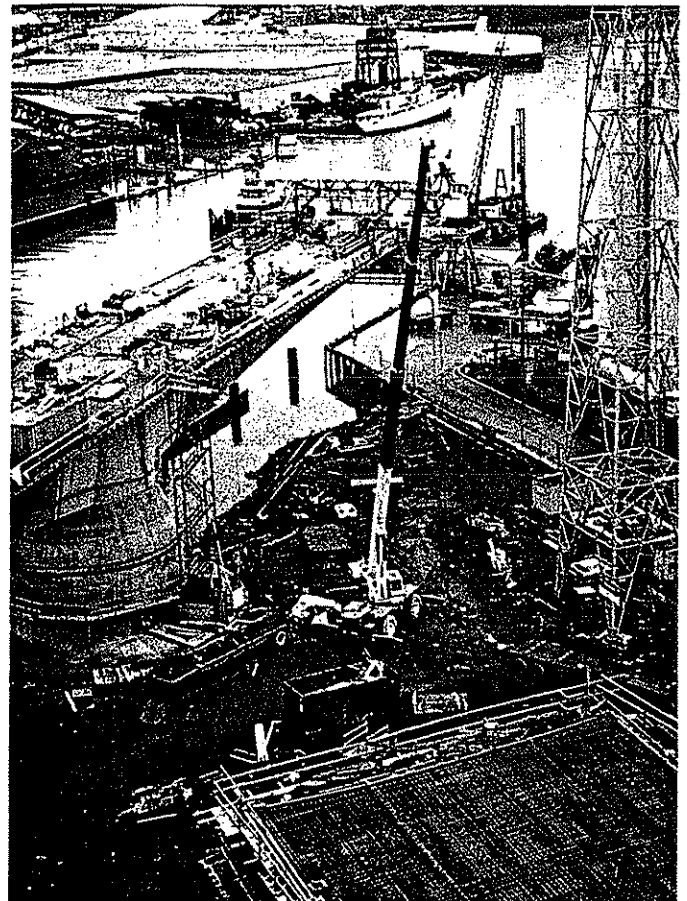

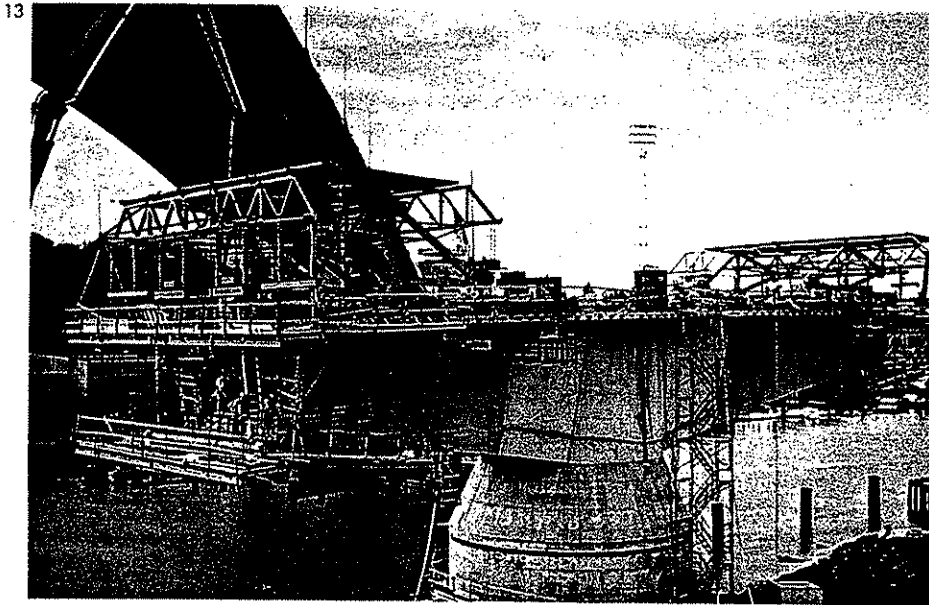

13-14. I lavori avanzano dai due lati della pila; i conci di c.a., realizzati in opera, hanno lunghezze variabili dai 4 ai 5 m ed altezze variabili dai 7 ai 2,1 m in chiave; 15. La costruzione delle due strutture che compongono il ponte è proceduta realizzando un cono ogni due settimane senza produrre intralci alla navigabilità del fiume; 16. Alla struttura di impalcato è stato applicato un sistema di precompressione sia longitudinale che trasversale; 17. Il progetto del ponte è stato condizionato dalle preesistenze che hanno «dettato» l'estetica dell'opera, la scelta dell'inclinazione dell'asse della nuova struttura nonché il verso delle rotazioni delle due semicampate.

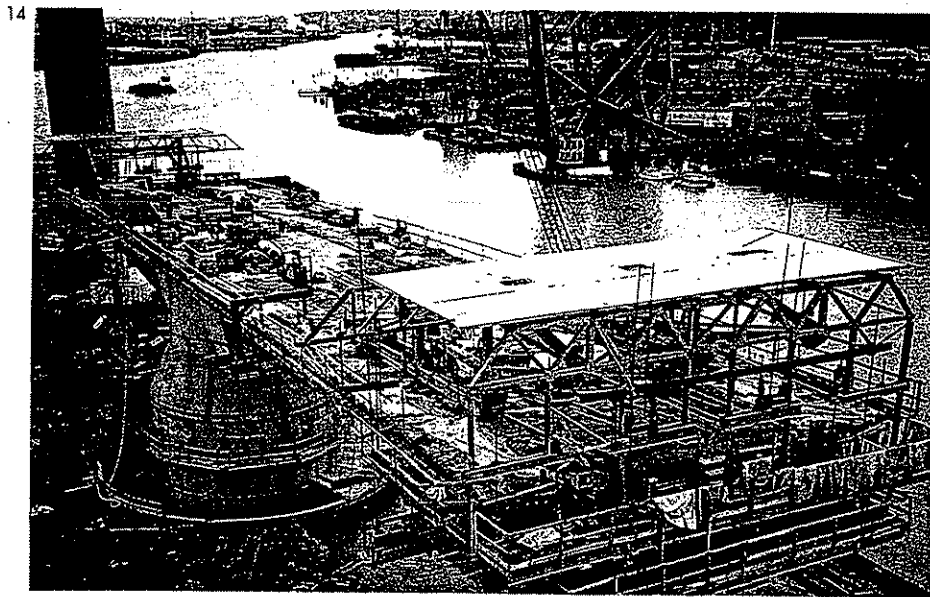

13-14. The work advanced from the two sides of the pier; the r.c. segments, cast in place, are from 4 to 5 m long and have depths of from 7 m to 2.1 m at the crown; 15. The construction of the two structures forming the bridge went ahead at the rate of one segment every two weeks. There were no obstacles to navigation of the river; 16. A longitudinal and crosswise prestressing system was applied to the deck structure; 17. The bridge design was conditioned by the existing construction, which «dictated» the structure's esthetics, the choice of the slope of the centerline of the new structure, as well as the sense of rotation of the two semispans.

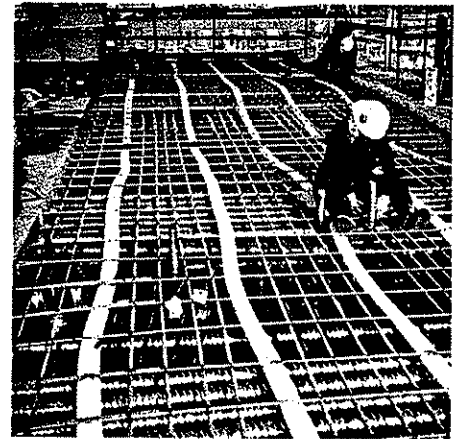
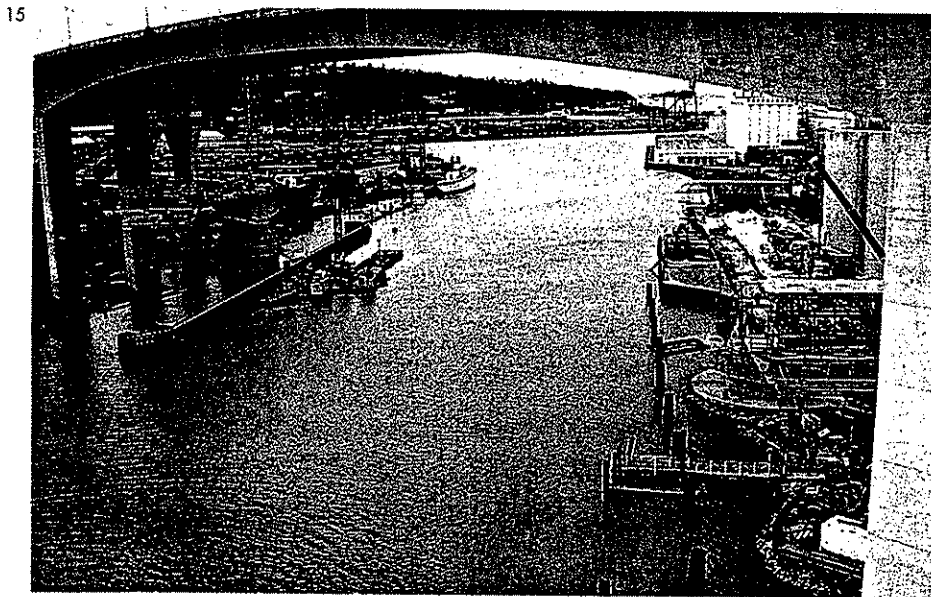

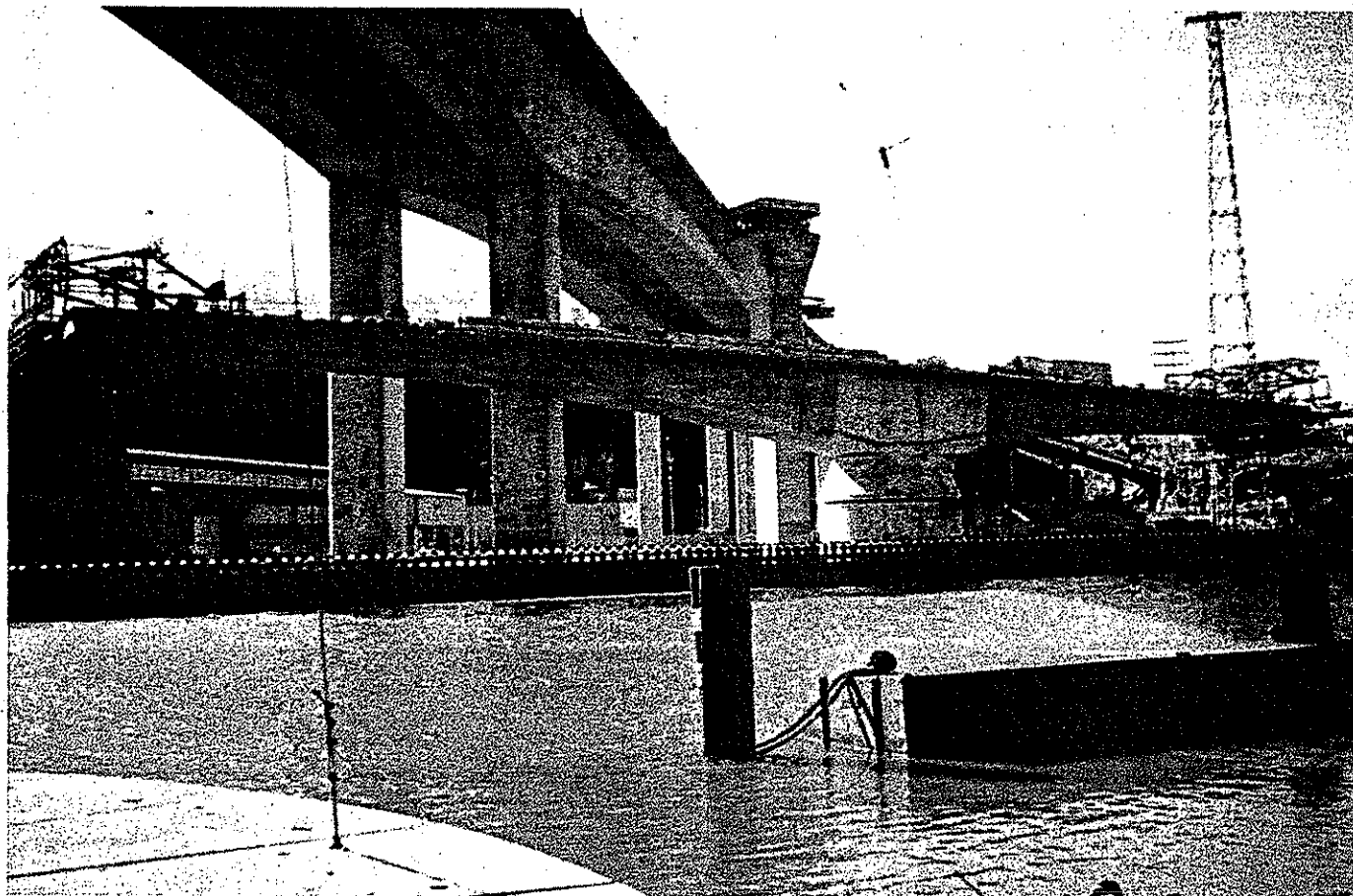

corso a supporti in bronzo di dimensioni irragionevoli, soggetti inoltre ad un alto grado di usura.

Per verificare l'efficacia del sistema di sollevamento e rotazione ora descritto, è stato costruito un modello in scala 1:2, che dopo una prova di simulazione di 10 anni di utilizzo continuato, si è conservato perfettamente integro, sia nei componenti meccanici che nelle guarnizioni.

È stato anche condotto uno studio per facilitare l'accesso all'interno delle pile per consentire le operazioni di manutenzione, ordinaria e straordinaria, delle apparecchiature meccaniche ivi alloggiare. In particolare, sono state predisposte aperture sufficientemente ampie da consentire la agevole rimozione e la sostituzione anche delle parti più ingombranti, quale il martinetto di sollevamento, del peso di 5 t.

Anche per il cassone dell'impalcato sono stati predisposti passi d'uomo sufficientemente ampi (1,22 m x 1,83 m) per consentire l'ispezione dell'interno e l'eventuale sostituzione dei macchinari per l'aggancio e la chiusura.

#### I PALI DI FONDAZIONE

Il ponte attraversa il fiume Duwamish

*the two spans was constantly checked during construction, the bridge being periodically closed. On the positioning of the two crown segments, the maximum departure in grade between the two spans was 15 mm: well within the tolerances laid down by the hooking mechanisms.*

*The box girder's upper slab is prestressed crosswise as well, while the webs are subject to vertical prestressing, even if in some parts of the deck the high longitudinal prestressing made it possible to reduce this.*

#### THE ROTATING PIERS

*The piers, 9.8 m high, are of hollow circular section, with an outside diameter of 12.8 m and walls 0.81 m thick; besides their obvious function of supporting the deck they also act as housing for a rotating shaft that lifts and rotates the deck, as well as for emergency generator sets and a part of the system of controls.*

*The vertical loads from the deck are transferred to the foundations through two alternative routes, selected by an r.c. transition element of truncated-conical shape. This element, when the bridge is in closed state (i.e. serving vehicle traffic), transfers the vertical load directly to the pier through elastomer-*

*coated steel plates set on a circle of diameter 11.4 m. When ships are to transit, the bridge is opened in two phases: the rotating shaft in the pier center exerts a lift on the central core of the transition element, raising the deck above by about 25 mm. Then two hydraulic jacks act on an eccentric connected to the rotating shaft, to provide the moment needed to swing the deck.*

*During this phase the deck bears directly on the rotating shaft, which is a metal pipe of 3.66 m diameter with 44 mm thick walls, filled with concrete. Its base in its turn bears on the cylinder of the hydraulic jack exerting the lift. One curious fact is that the jack diameter, 3.66 m, which determined the dimensioning of the whole rotating shaft, was essentially dictated by the size of the largest gas-ket available on the market.*

*The verticality of the rotating shaft during rotation is maintained by two guides set nearby the shaft base and top. During the rotation of the bridge these guides provide the sole, however negligible, source of friction, since at its base the rotating shaft may be considered as floating on the fluid of the lifting jack. The decision to provide a floating structure was obligated by the weight of the deck. Ordinarily, in swing bridges the rotation is effected around a central support, but in this case the great weight of the spans would have*

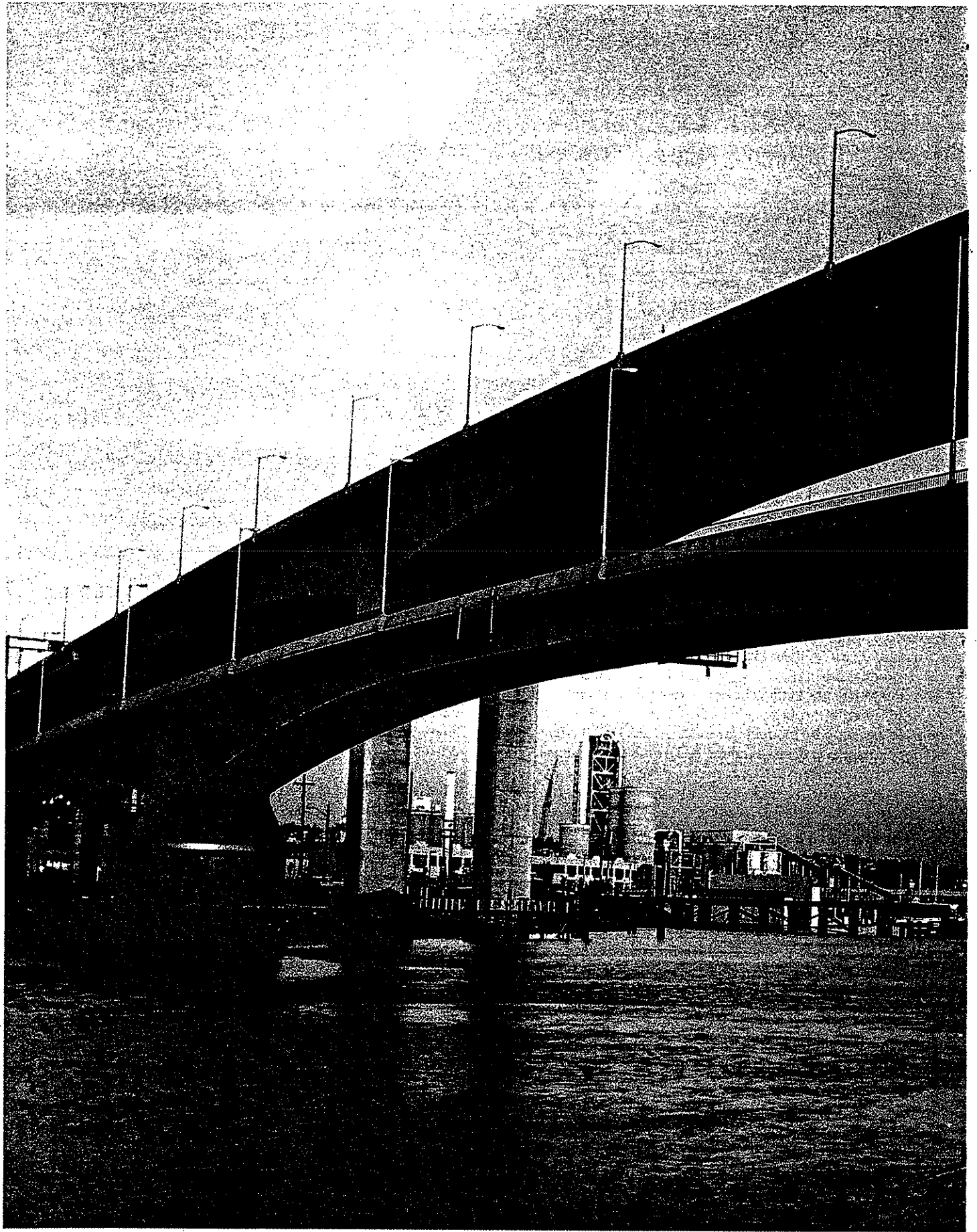

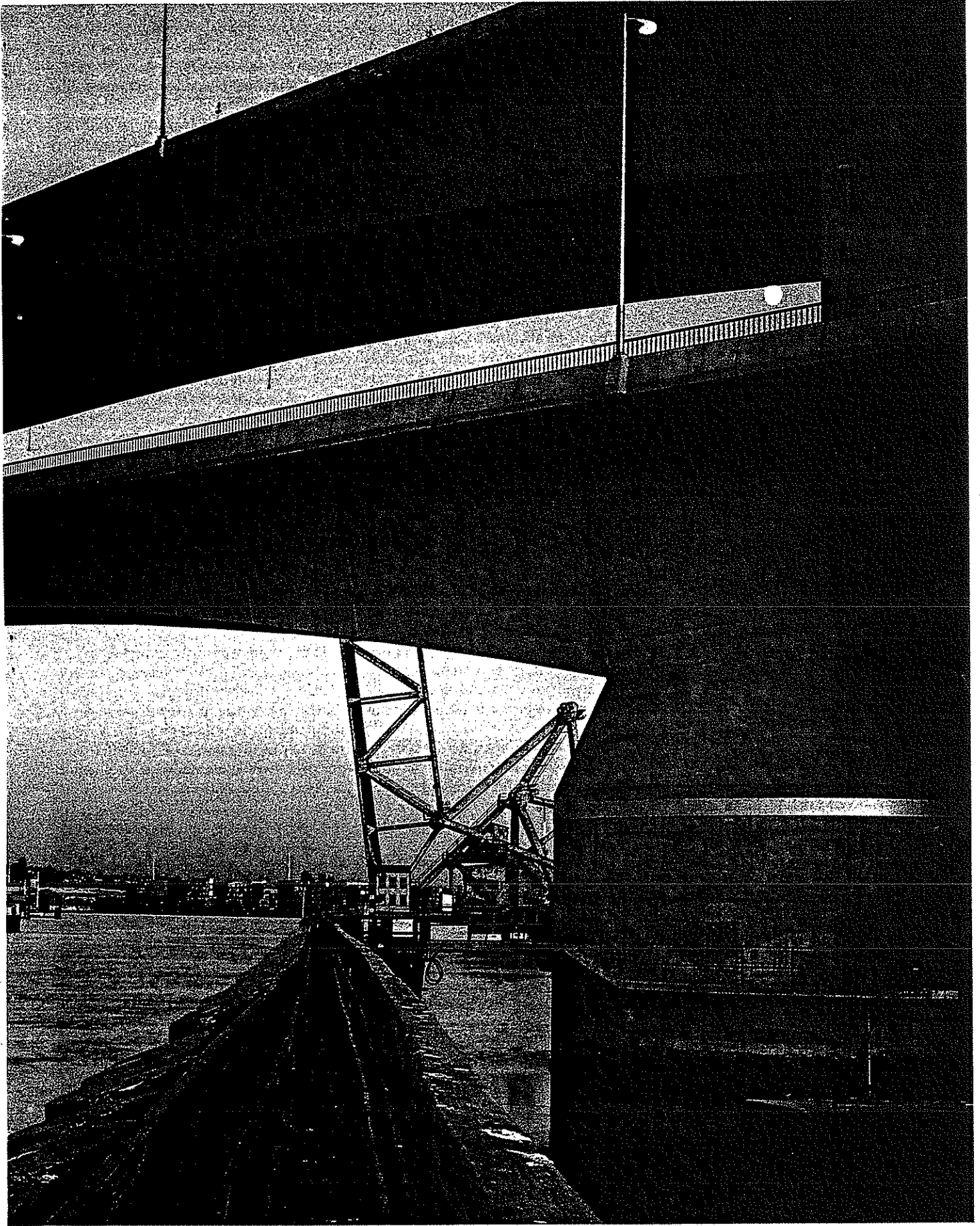

nelle vicinanze della foce ed è fondato su pali. La composizione del suolo sulle rive del fiume varia da un iniziale rilevato costruito con metodi idraulici, da sabbie alluvionali recenti, fino a strati limosi di origine glaciale fortemente preconsolidati, la cui profondità varia da 15 m sulla riva ovest del canale fino a 60 m sulla riva est. Sono inoltre presenti, distribuite casualmente nello strato alluvionale, lenti di limo e il rilevato superiore determinano un suolo di fondazione fortemente instabile in superficie e ad alto potenziale di liquefazione, certamente non in grado di sopportare le azioni indotte da un evento sismico di elevata intensità.

L'area su cui sorge il ponte è moderatamente attiva dal punto di vista sismico e corrisponde approssimativamente alla zona 3 italiana ( $S=6$ ), con accelerazione al suolo di 0,032 g. L'accelerazione spettrale, valutata per un fattore di amplificazione di 2,2, è risultata pari a 0,07 g.

Per far fronte al problema citato, si è optato per l'addensamento del terreno di fondazione con tecniche di vibroflottazione, al fine di impedire la perdita di contenimento laterale attorno alla porzione superiore dei pali in caso di spostamenti laterali del terreno dovuti al sisma.

La pendenza delle rive del canale dava luogo all'ulteriore problema che i pali ivi infissi avrebbero avuto rigidità trasversali diverse fra loro, poiché la profondità dello strato meno addensato variava da palo a palo. Questo avrebbe portato ad una notevole eccentricità del centro di rigidità rispetto al centro di massa, con la conseguente generazione di torsione indesiderata nella fondazione della pila.

Il problema è stato risolto, in maniera alquanto innovativa, con l'adozione di «camicie» per l'isolamento sismico disposte attorno ai pali di fondazione delle pile. L'esecuzione delle fondazioni su pali prevedeva dapprima l'infissione delle camicie, tutte di eguale lunghezza, e successivamente l'infissione dei pali, la posa delle armature ed infine il riempimento con calcestruzzo vibrato. La costanza della distanza anulare fra il palo e la camicia era assicurata da apparecchiature per il controllo della centratura.

Ogni palo di fondazione, della lunghezza complessiva di 18 m, risulta alla fine incapsulato in un tubo metallico del diametro di 1,22 m e della lunghezza di 12,5 m. Lo scopo dell'impiego di queste «camicie» è di far sì che, sotto azione orizzontale, tutti i pali fruiscono della resistenza laterale del terreno circostante a partire dalla stessa profondità. Tale profondità è stata de-

terminata in modo da ottenere il bilanciamento ottimale fra la flessibilità del gruppo di pali e i momenti derivanti dall'azione sismica. In tal modo, il palo posto sotto l'angolo della fondazione, che risulta teso, raggiunge esattamente il momento di plasticizzazione in corrispondenza del terremoto di progetto. In queste condizioni, lo spostamento previsto per la pila in sommità, valutato considerando anche l'interazione con la struttura di fondazione, è di circa 50 mm.

#### CRITERI DI CALCOLO E PROBLEMI COSTRUTTIVI

Un problema affrontato con particolare cura in sede di progetto è stato il controllo nell'impalcato in c.a.p. delle deformazioni a lungo termine. Particolare rilievo è stato dato alla necessità di costruire le due campate girevoli simultaneamente e seguendo esattamente lo stesso piano di tesatura, in modo da avere un identico sviluppo nel tempo delle deformazioni viscosse e di ritiro.

Si sono comunque impiegate tutte le tecnologie più moderne per ottenere un calcestruzzo di resistenza elevata con deformazioni viscosse e di ritiro minime, utilizzando superfluidificanti per ridurre il contenuto in acqua ed assicurare la lavorabilità necessaria. La precompressione veniva applicata al raggiungimento della resistenza minima del calcestruzzo, misurata attraverso termocoppie immerse nel getto di calcestruzzo.

Nella fase di progettazione del sistema di precompressione longitudinale, la strategia seguita per minimizzare le deformazioni a regime ha sostanzialmente implicato l'adozione del principio del totale bilanciamento del carico permanente. L'entità della precompressione applicata ai due impalcati è stata tale da equilibrare il 100% dei carichi permanenti in condizione a regime. Questo ha richiesto circa il 30% in più di cavi rispetto a quelli strettamente necessari per soddisfare le verifiche tensionali.

Le fondazioni delle due pile appartenenti al vecchio ponte basculante in acciaio sono state demolite con gli esplosivi usando una metodologia, denominata «air curtain», che ha consentito di salvaguardare la fauna fluviale dai detriti derivanti dalle esplosioni, assorbendo quasi l'80% delle onde di pressione create da ogni esplosione subacquea. Il problema della protezione della fauna fluviale è stato affrontato anche da un altro punto di vista, la cui importanza è stata evidenziata dal Diparti-

mento della Pesca dello Stato di Washington. Infatti, il canale rappresenta un punto di accesso per i branchi di salmoni che migrano verso l'oceano in periodi specifici dell'anno, per cui, al fine di non ostruire il passaggio, le imprese esecutrici si sono impegnate a non eseguire lavori in acqua nei periodi di migrazione (tre mesi circa).

Ogni campata è stata eretta assemblando 25 conci di lunghezza variabile da 4 a 5 metri, al ritmo di uno ogni due settimane. Poiché però i due sbalzi di ogni campata girevole hanno lunghezza differente, si è reso necessario procedere alla loro costruzione rispettando in ogni istante l'equilibrio statico della stampella rispetto all'appoggio sulla sommità della pila, onde evitare il ribaltamento dell'impalcato sul pulvino. All'interno del cassone erano comunque previsti appositi alloggiamenti per posizionare blocchi di ballast, da impiegare quando si presentava la necessità di operare correzioni dell'equilibrio in corso d'opera. Il rispetto dell'equilibrio in condizioni finali è stato ottenuto proporzionando gli spessori delle pareti del cassone dello sbalzo di luce minore in maniera tale che il suo peso bilanciava esattamente quello dello sbalzo di luce maggiore. Le zone terminali degli sbalzi corti sono comunque a sezione piena per una lunghezza di 12 m.

Dopo la posa in opera di ogni concio e dopo ogni fase di tesatura venivano eseguiti rilevamenti sistematici delle frecce su entrambe le campate, per verificare le previsioni ottenute in sede di progetto. Nel corso di tali misurazioni si è constatato che per prevedere analiticamente l'equilibrio delle campate a sbalzo era necessaria la conoscenza accurata dei pesi in gioco, per cui si è reso necessario il prelievo continuo di campioni di calcestruzzo per poterne valutare la reale densità, nonché la pesatura dei cavi in acciaio effettivamente impiegati in ogni concio.

I problemi affrontati durante la costruzione sono stati notevoli a causa dell'intenso traffico industriale della zona, che non conosce soste di giorno e di notte. Nel corso dei lavori è stato spostato un traliccio elettrico, che fornisce energia a tutta la zona residenziale ovest, senza interrompere l'afflusso di energia elettrica, ed anche i servizi idrici e telefonici sono stati assicurati durante tutto il periodo dei lavori, anche quando è stato necessario spostare i condotti e i cavi che intralciavano i lavori. Tutti gli abitanti ed il personale marittimo della zona venivano costantemente aggiornati sul procedere dei lavori e ogni deviazione del traf-



PROFILI DEL PONTE E STRUTTURE DI FONDAZIONE

1. Andamento planimetrico del ponte, e schema di apertura dell'impalcato; 2. Profilo longitudinale del ponte e dei due viadotti adiacenti; 3. Pianta parziale della fondazione del pilor; 4. Sezione verticale della fondazione della pile impostato su pali.

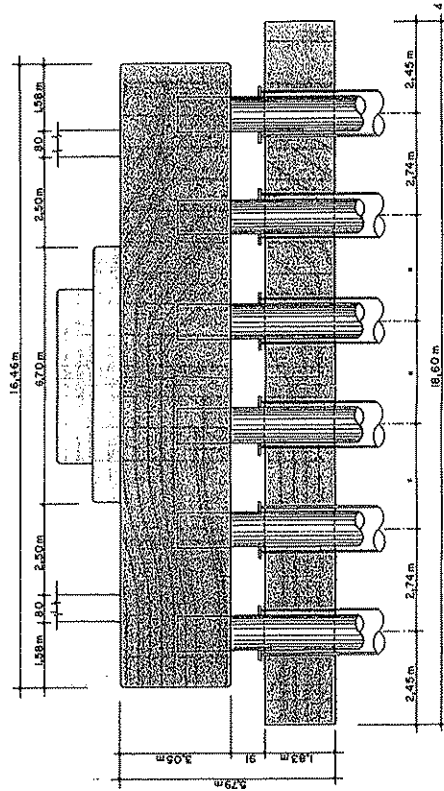
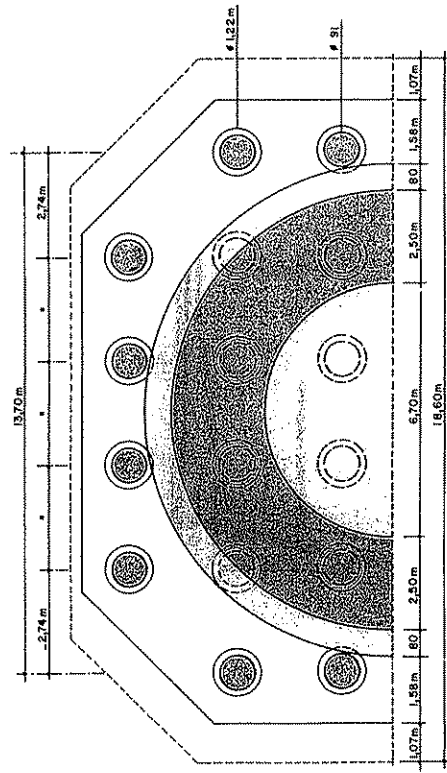
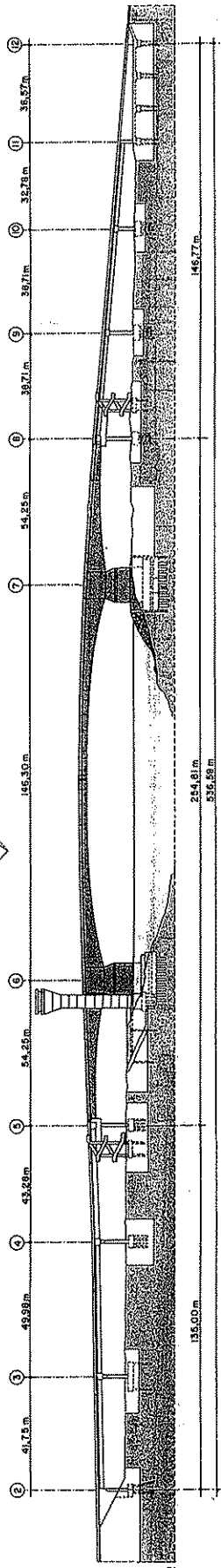
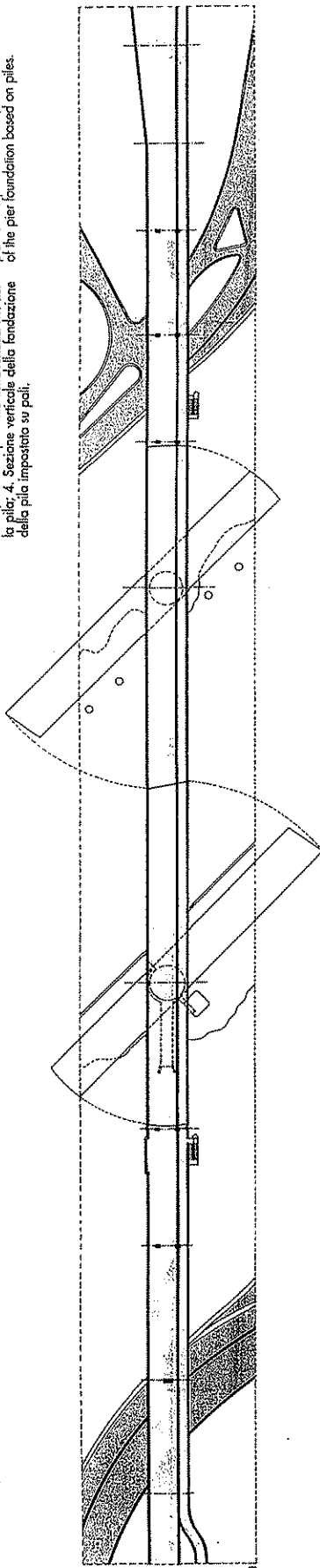

IMPALCATO

... 5-6. Prospetto e pianta della semistruttura di impalcato con l'indicazione dei corci, lato ovest; 7. Andamento dei corci di precompressione dell'impalcato; 8-9-10. Sezioni trasversali di impalcato in corrispondenza della pila ed in mezzapila: posizione dei corci di precompressione.

DECK

... 5-6. Elevation and plan of the deck semi-structure with indication of segments, west side; 7. Prestressing cable lay out of the deck; 8-9-10. Cross sections of the deck at the pier and midspan: prestressing cable lay out.

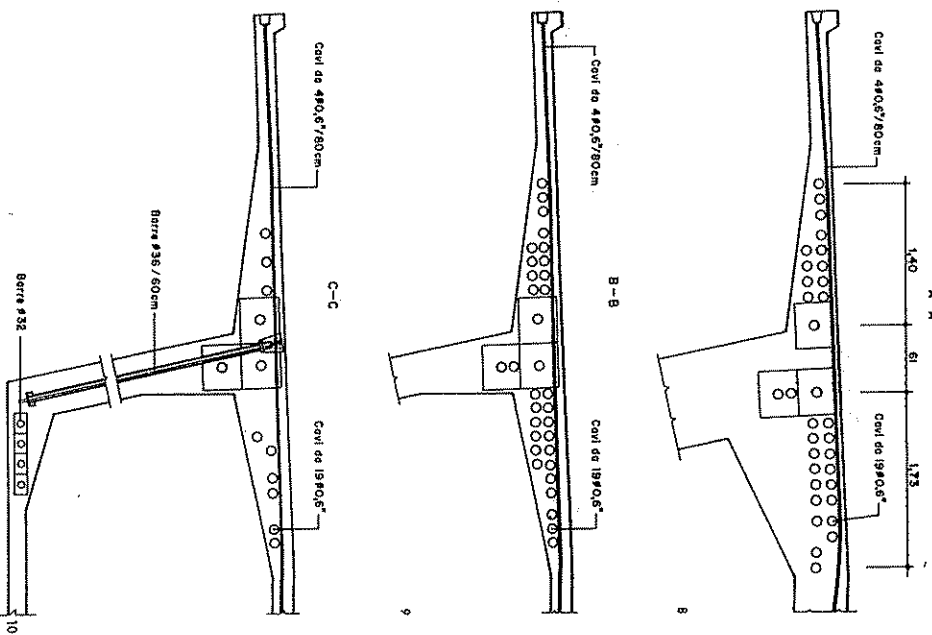
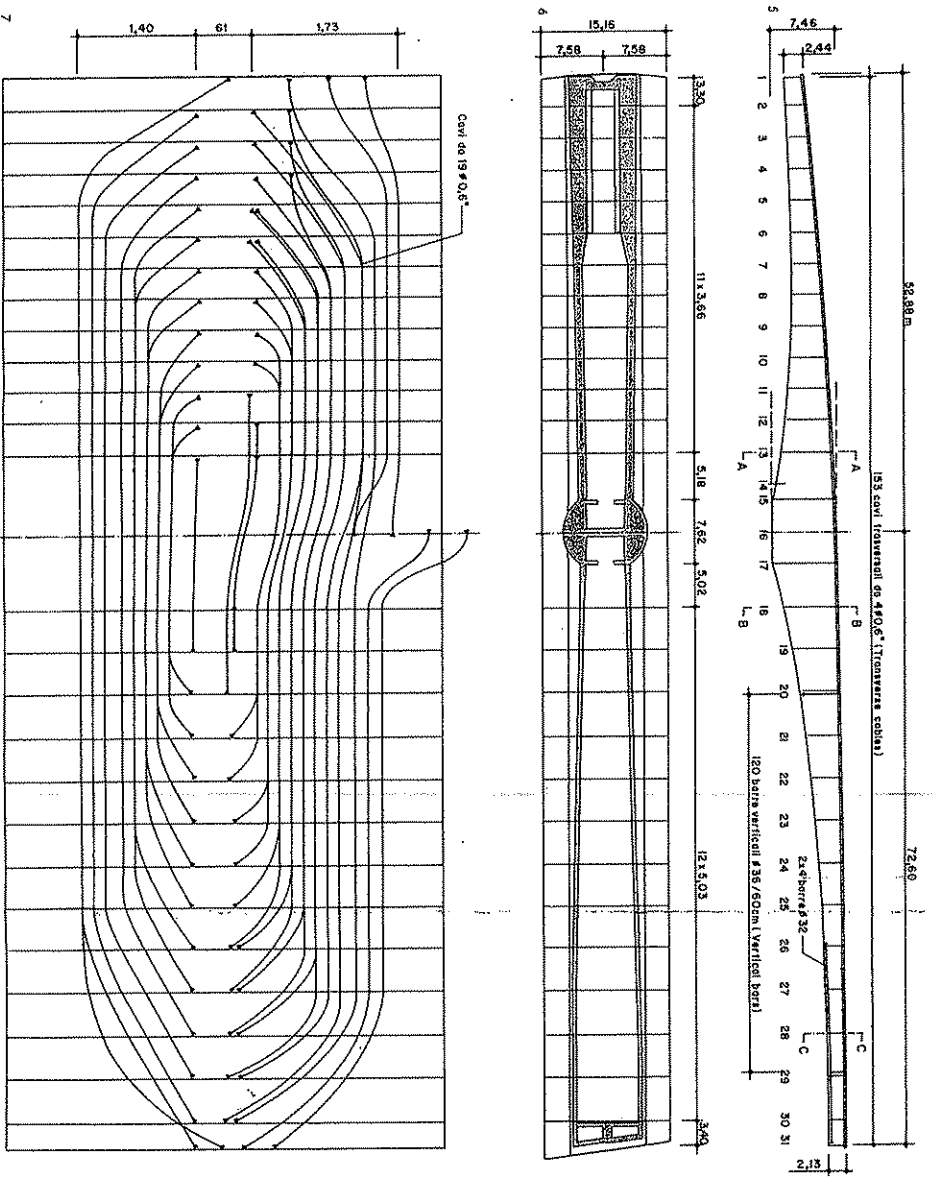

IMPALCATO: CARPENTERIA

DECK: DIMENSIONS

11. Sezione verticale dell'impalcato in corrispondenza della pila; 12. Sezioni in corrispondenza del collegamento impalcato-testa pila; 13. Sezione trasversale del concio n. 14; 14. Sezione trasversale del concio n. 18; 15. Sezione trasversale del concio n. 2; 16. Sezione trasversale del concio n. 30.

11. Vertical deck section at pier; 12. Sections at the deck-pierhead connection; 13. Cross section of segment n. 14; 14. Cross section of segment n. 18; 15. Cross section of segment n. 2; 16. Cross section of segment n. 30.

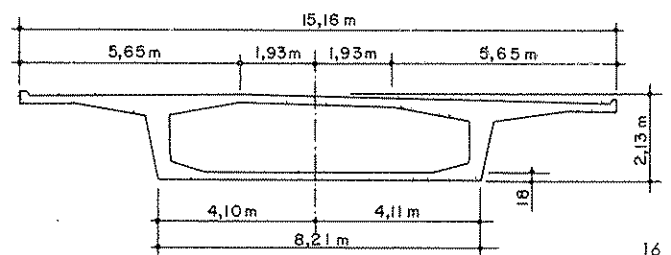
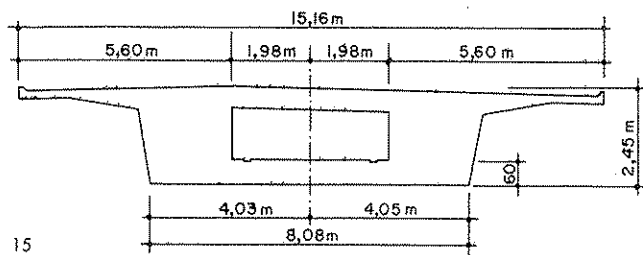
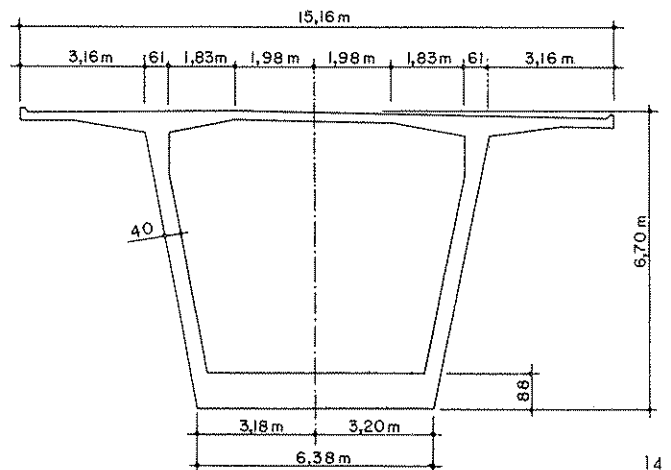
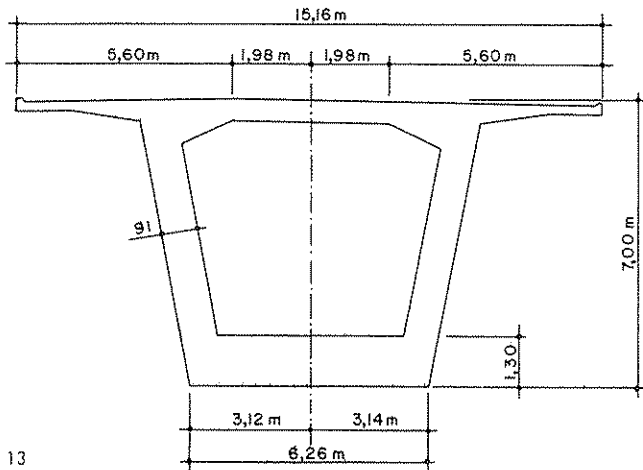
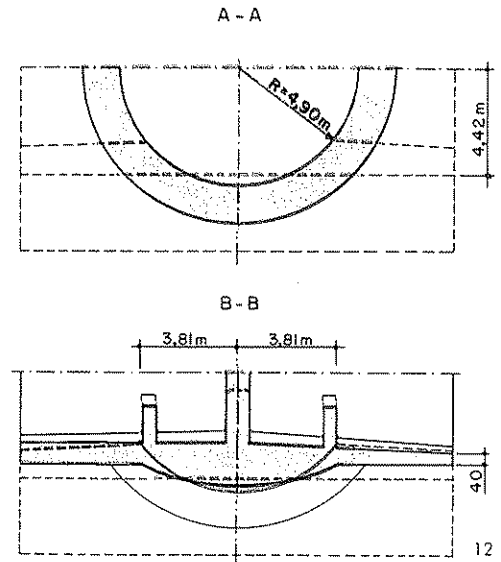
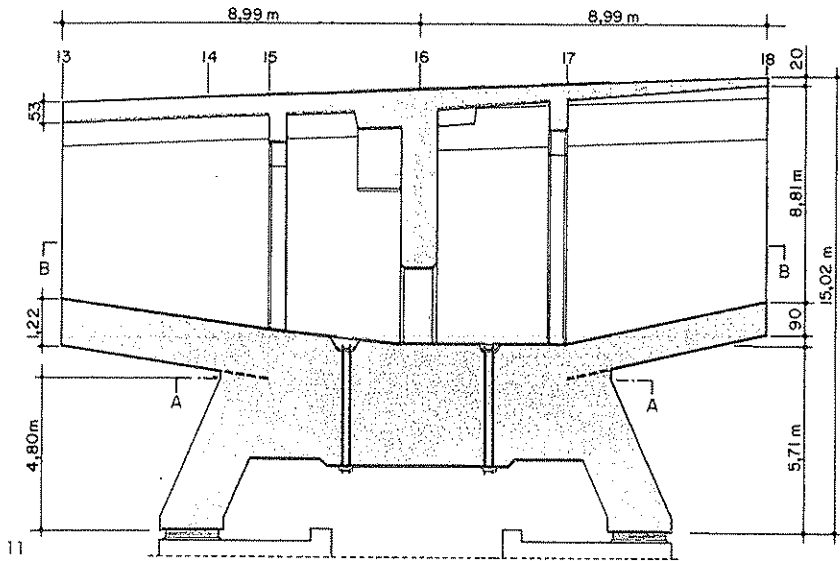

PILA

PIER

17. Prospetto e sezione verticale della pila contenente il meccanismo di sollevamento e rotazione dell'impalcato

17. Elevation and vertical section of the pier containing the lift/turn cylinder for the deck movement.

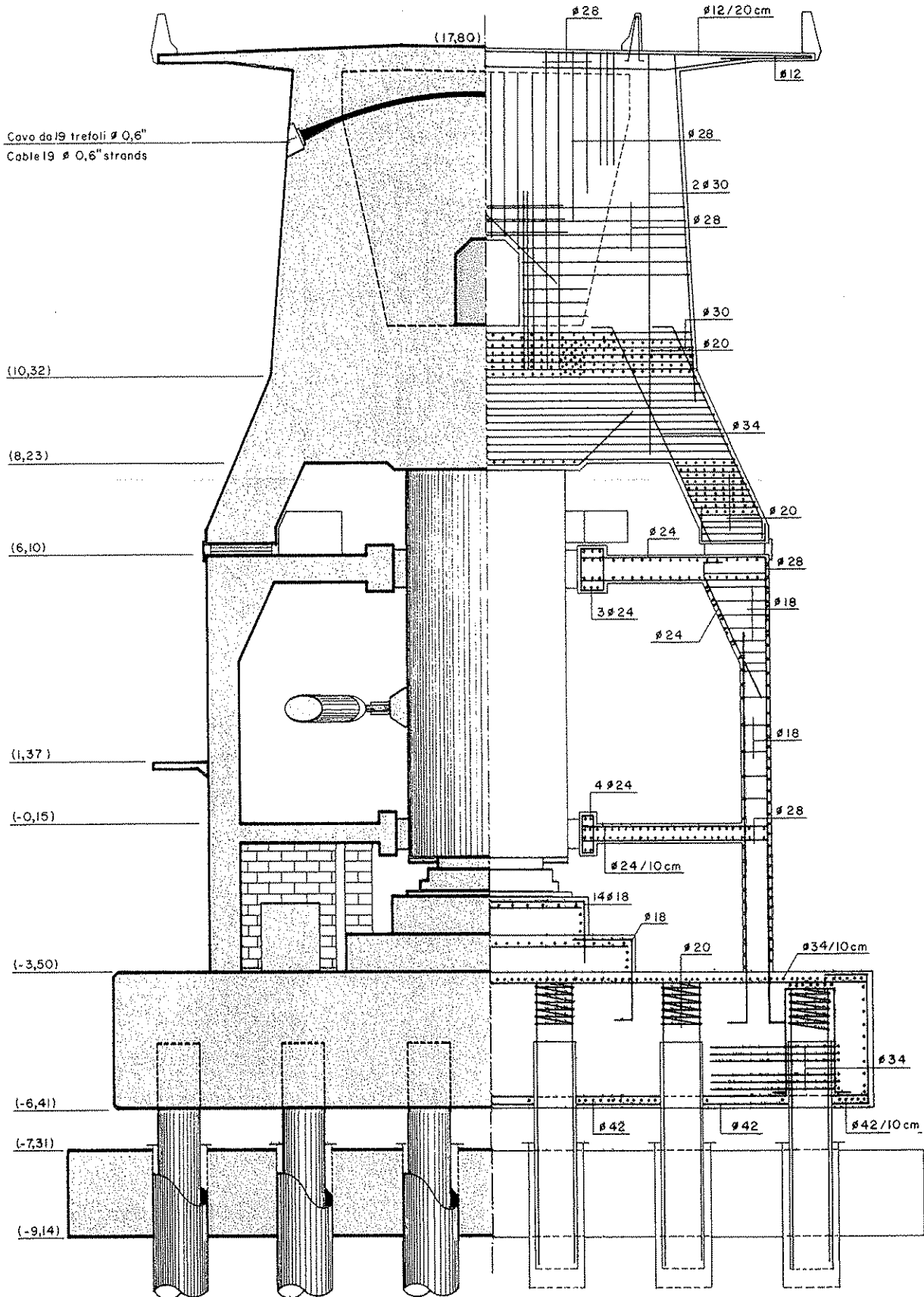

demanded the resort to bronze bearings of unreasonable size, which would also have been subject to a high rate of wear.

In order to verify the effectiveness of the lifting and rotation system just described, a model to scale 1:2 was built; after a simulation test of ten years of continuous use, the mechanical components and the gaskets were found to be perfectly conserved.

A study was also made to facilitate access to the pier interiors to permit ordinary and special maintenance operations on the mechanical equipment housed there. In particular, openings large enough to permit easy removal and replacement of even the bulkiest parts, such as the hoist jack (weighing 5 tons) were provided.

For the deck box too manways large enough (1.22 m x 1.83 m) to permit inspection of the interior and any replacement of the machinery for hooking-on and closure were provided.

#### THE FOUNDATION PILES

The bridge, which crosses the Duwamish river nearby its mouth, is founded on piles. The composition of the soil on the river banks varies from a topmost fill laid with hydraulic methods, through recent alluvial sands, down to strongly consolidated silty strata of glacial origin. Their depth runs from 15 m on the west bank of the channel to 60 m on the east bank. Present too, randomly distributed in the alluvial stratum, are not-very-dense lenses of silt. The surface stratum of silt and the topmost fill create a foundation soil that is highly unstable on the surface with a high liquefaction potential – surely not suited to taking the forces induced by a high-intensity earthquake.

The area the bridge stands in is moderately active seismically and corresponds roughly to the Italian zone 3 ( $S = 6$ ), with soil accelerations of 0.032 g. The spectral acceleration, evaluated for an amplification factor of 2.2, is 0.07 g.

To solve the problem mentioned, design opted for soil compaction by vibroflotation techniques, in order to prevent the loss of lateral containment around the upper portion of the piles in case of side shifts of the soil due to earthquake.

The slope of the channel banks gave rise to a further problem, for the piles driven there would have differing crosswise stiffnesses, since the depth of the least compacted stratum varied from pile to pile. This would have led to a considerable eccentricity in the center of stiffness relative to the center of mass, with the consequent undesirable generation of torsion in the pile foundation.

The problem was solved, in rather innovative fashion, by the adoption of seismic insulation jackets placed around the pier foundation piles. The construction of the foundations on piles called first for driving the jackets, all of equal length, and then driving the piles, laying the reinforcing and finally filling them with vibrated concrete. The annular distance between the pile and its jacket was kept constant by equipment for the control of their centering

Each foundation pile, 18 m long, is then at the end sheathed in a steel pipe of diameter 1.22 m and 12.5 m long. The purpose of these jackets is to ensure that under horizontal forces all piles make use of the side strength of the surrounding ground starting from the same depth. This depth was determined in such fashion as to obtain the optimum balance between the flexibility of the pile cluster and the moments arising from seismic forces. Thus, the pile set below the corner of the foundation, which is in traction, reaches exactly the plasticization moment of the design earthquake. Under these conditions the shift envisioned for the pile at its top, evaluated considering its interaction with the foundation structure, is around 50 mm.

#### CALCULATIONS CRITERIA AND CONSTRUCTION PROBLEMS

One problem design tackled with considerable care was the control of the long-term strains in the prestressed-concrete deck. Special importance was given to the need to build the two swing spans simultaneously and following exactly the same tensioning plan, in order to have an identical development over time of the strains due to creep and shrinkage.

Even so, all the most modern technologies were used to obtain a high-strength concrete exhibiting minimum creep and shrinkage, reducing the water content and using superfluidizers to ensure the necessary workability. The prestressing was applied when the concrete reached its minimum strength, measured by means of thermocouples sunk in the pour.

During the design of the longitudinal prestressing system, the strategy followed to minimize strain at full operation substantially implied the adoption of the principle of the total balancing of the permanent load. The size of the prestressing applied to the two decks was such as to completely balance the permanent loads at full operation. This demanded about 30% more cables over those strictly necessary to meet the stress checks.

The foundations of the two piers belonging to the old steel bascule bridge were demol-

ished with explosives, using a method, called the "air curtain", that safeguarded the river fauna from the detritus resulting from the explosions, almost 80% of the pressure waves created by each underwater explosion being absorbed. The problem of the protection of the river fauna was taken on from another aspect too, whose importance was brought out by the Fishing department of the State of Washington. In fact, the channel is a point of access for the schools of salmon that migrate towards the ocean during certain periods of the year, so that, in order not to block their passage, the contractors undertook not to carry on work in the water during the migration periods (three months long).

Each span was erected by assembling 25 segments from 4 to 5 meters long, at the rate of one every two weeks. Since however the two cantilevers in each swing span are of different lengths, it was necessary to built them complying at all times with the static equilibrium of the tee taken around the pier-top bearing, in order to avoid the capsizing of the deck. On the box interior there were anyway provided special housings to position blocks of ballast, to be used when the need arose to create corrections in the balance as the work went ahead. Equilibrium under final conditions was obtained by proportioning the thickness of the box walls of the lesser span cantilever in such fashion as to have its moment exactly balance that of the long-span cantilever. The end zones of the short cantilevers were anyway made full-section over a length of 12 m.

After each segment was set in place and after each tensioning phase systematic surveys were made of the deflections on both spans, to check the design forecasts. During these surveys it was found that in order to predict analytically the balance of the cantilevered span it was necessary to accurately know the weights in play, so that the continuous sampling of concrete to evaluate its true density became necessary, as did the weighing of the steel cables actually used in each segment.

The problems solved during construction were noteworthy, owing to the intense industrial traffic in the area, which never sees a pause, day or night. During the job an electrical tower, which supplies power to the whole west residential area, had to be shifted without interrupting the flow of power; water and telephone service was also assured during the whole job, even when it was necessary to shift those utilities lines that were getting in the way of the work. All inhabitants and the sailing personnel in the area were kept constantly updated on the progress of the job, and every detour in local traffic was agreed upon and discussed with representatives of the cit-

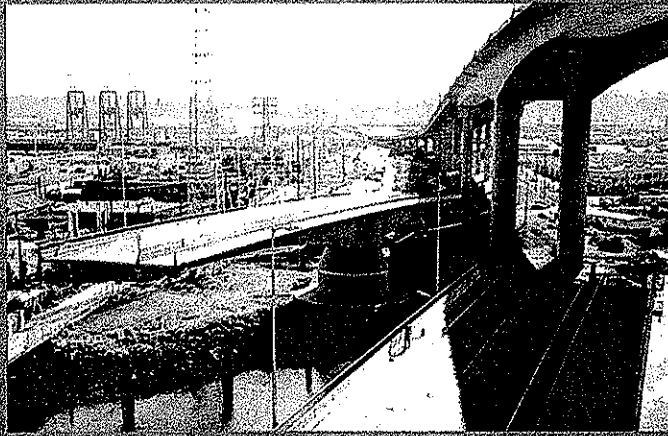
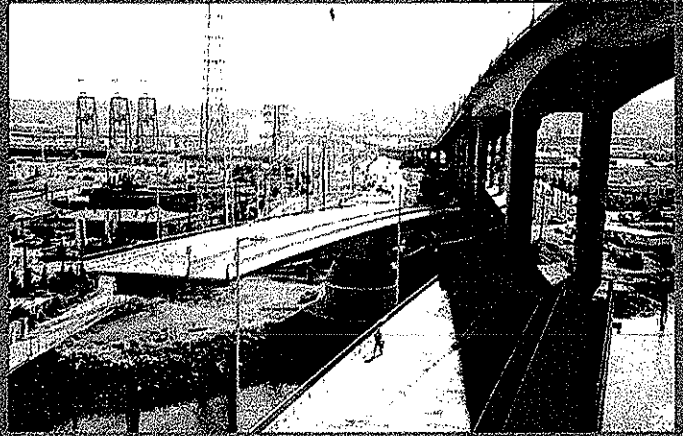
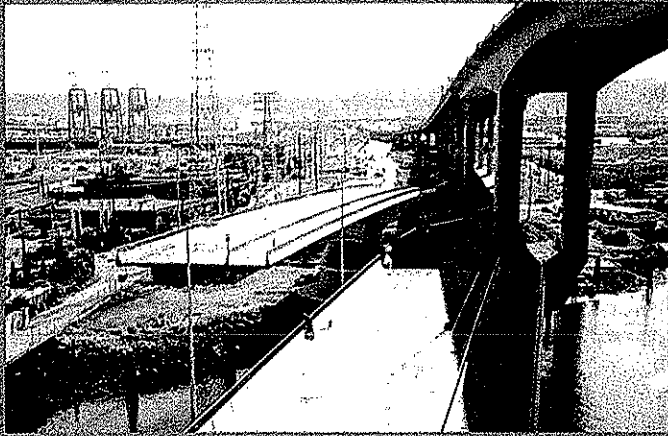



Fasi dell'apertura delle due semi-compate del ponte. Il meccanismo prevede il sollevamento di 25 mm dello stampello mediante l'albero rotante posto all'interno delle pile e la successiva rotazione una di verso opposto all'altra sponda. Durante l'apertura l'impalcato poggia direttamente sull'albero rotante la cui base è posta sul cilindro del martinetto idraulico che esercita il sollevamento.

Phases in the opening of the two bridge semispans. The mechanism involves the lifting of the tee by the rotating shaft set inside the pier, and its subsequent rotation in opposite senses on the two sides. During opening the deck bears directly on the rotating shaft whose base is set on the cylinder of the hydraulic jack that exerts the lifting force.

fico locale veniva concordata e discussa con i rappresentanti dei cittadini, con i membri delle delegazioni dei commercianti e con i titolari delle ditte di navigazione.

izens, with the members of the businessmen's delegations, and with the owners of the sailing companies.

\* \* \*

\* \* \*

Il progetto è stato eseguito dal consorzio WSB-2 Design Team, composto dalla Andersen Bjornstad Kane Jacobs Inc., dalla Parsons Brinckerhoff Quade and Douglas Inc., e dalla Tudor Engineering Company. Il progetto dell'impalcato in c.a.p. è opera del Contech Consultants Inc.

The design was by the WSB-2 Design Team syndicate, composed of Andersen Bjornstad Kane Jacobs Inc., of Parsons Brinckerhoff Quade and Douglas Inc., and of the Tudor Engineering Company. The prestressed-concrete deck was designed by Contech Consultants Inc.

