

INFANTRY AND CAVALRY SCHOOL
DEPARTMENT OF ENGINEERING



NOTES ON
Rangefinders, Compasses and
on Contouring with the Scale
of Horizontal Equivalentents



March, 1905.



RANGE FINDERS.

Range Finders are of two general classes; those used in connection with permanent fortifications, which are combined range and position finders, and those used for estimating ranges on the battle-field for light artillery and small arms fire. Those of the latter class are usually called telemeters, and they are the ones with which we are principally concerned, considering them both as battle-field range finders and as surveying instruments.

Most of these measure the distance by a triangulation, one of the angles of the triangle being a right angle. As an aid to the understanding of their use and operation let us consider two simple triangulation problems with the sextant.

Problem 1—To find the distance of a point using a right angled triangle with constant base.

In Fig. 1, Plate 1, let A be the position of the distant point and C that of the observer. Having set the sextant at 90° lay off the line CD perpendicular to CA and on this line measure the adopted length of base CD and mark the point D. Measure with the sextant the angle between DC and DA. The required distance is the known length of base multiplied by the tangent of the observed angle. If the distance to B is required, all the factors remain the same except the angle at D.

Problem 2—To find the distance of a point using a right angled triangle with varying length of base and a constant angle at base.

In Fig. 2, Plate 1, let A be the position of the distant point and C that of the observer. Setting the sextant at 90° lay off the line CE perpendicular to CA. Then set the sextant at the constant angle and move to the right on this line until the point D is reached, where the point C, seen directly, and the point A, by reflection, coincide. The required distance is the measured base, CD, multiplied by the tangent of the constant angle. If the distance to B is required we would obtain coincidence at F, all the factors remaining the same except the length of the base.

Most of the battle-field range finders are simple instruments for solving one or the other of these problems.

The Watkin Mekometer is the range finder adopted for all arms of the British service. It is a contrivance for mechanically solving Problem 1, and consists of two instruments each having reflecting mirrors like those of the sextant. The base is determined in length by a cord which may be made 25, 50, 75 or 100 yards long by using parts of the cord separately or linked together. The two instruments are attached to the ends of the cord. The one at the left has fixed mirrors which deviate the rays through an angle of 90° . In the one at the right, one of the mirrors is movable like the index glass of a sextant, and permits the angle at that end of the base to be measured. (See Figs. 3 and 4, Plate 2.) Over the mirrors, each instrument has a vane which when raised presents a vertical strip of ivory toward the other instrument for accurate sighting. Fig. 4 shows the drum at the back of the right-hand instrument by means of which the mirror is turned. On the drum is a spiral line graduated with a tangent scale that reads distances directly instead of angles. If, however, the drum is graduated for the 25 yard base its

readings must be multiplied by two for the 50 yard. base, by three for the 75 yd. base, and bary four for the 100 yard base.

The two observers, No. 1 on the right and No. 2 on the left, pick out the object to which the range is desired and by consultation agree on the exact point of the object that they will sight at. They then move, Fig. 5, Plate 2, No. 1 to the right to C and No. 2 to the left to A, reeling out the cord as they go. No. 1 attaches his instrument to the cord and stands fast at C. He sights through his instrument direct at the distant point D, and when No. 1 is ready, turns the mirror to get coincidence of the ivory of No. 2's instrument at A seen by reflection with the distant point D seen direct. No. 2 attaches his instrument to the end of the cord, and keeping the cord taut moves backward or forward at A till the ivory of No. 1's instrument, seen by reflection coincides with the distant point D seen direct. When he has this coincidence he calls out to No. 1, and No. 1 verifies his own coincidence and then reads the range on the scale.

A number of simple range finders have been devised for speedily solving Problem 2. Some of them have two sets of mirrors fixed in position, one for measuring the right angle and the other for measuring the selected angle at the base; usually $88^{\circ}51'15''$, the tangent of which is 50. This gives a convenient multiplier and a base of reasonable length compared to the distance to be measured. Other types have separate silvered prisms for measuring these angles while in a third class a compound prism is used with two adjacent faces slightly different in angle, the deviation of the ray from the object to the eye and the consequent measurement of the angle depending on the face from which the ray is allowed to emerge, the one not used being covered by a sliding shutter.

Of the first class mentioned is the Pratt Range Finder Plate 3, Fig. 2. One set of mirrors is fixed at 45° and the other set is adjustable so that it can be set at different angles to vary the tangent of the double angle through which the ray is deviated and consequently the multiplier of the instrument. This is however only a matter of adjustment, and once set to any angle the multiplier remains constant until the instrument is again adjusted to some other angle. Suppose it is set at $44^\circ 25' 37.5''$ the angle of deviation would then be the usual one of $88^\circ 51' 15''$ making the the multiplier of the instrument 50. With this assumption an explanation of the operation of this instrument in detail will make clear all others of similar principle.

Examining the figure, A and B show the position of one set of mirrors, the open space C, being used for viewing the object direct. The back of the other set of mirrors is shown at D. In using this set the instrument is turned and the same open space used as if it were the clear part of the horizon glass of a sextant. The instrument when not in use is reversed into the cylindrical case. Now considering Fig. 3, Plate 1, the observer stands at C facing the distant object A, using the mirrors for determining the position of a line C E at right angles to the one joining C and A. He ranges in a pole at E so that its reflected image appears to coincide with A, the ray first coming to the mirror at G, then to the other mirror at H and then to the eye at C in the direction HC or apparently from A, the angle ACE being 90° . If now the observer uses the other set of mirrors the ray from the same pole at E will no longer come apparently from A but from A' the angle A'CE being $88^\circ 51' 15''$. If now the observer moves to the right in prolongation of the line EC always keeping the pole at E visible in the mirror, the line

A'C will move through a series of positions parallel to its original direction until a point D is reached where it passes through A. We then have the right angled triangle ACD in which the measured base CD multiplied by the tangent of $88^{\circ}51'15''$, the fixed angle, or by 50, is the required distance CA.

The Weldon Range Finder, now used in our light artillery service, is illustrated in Fig. 1, Plate 2. It is like the pratt in principle and in the manner of using it. The rays are deviated by passing through prisms instead of by double reflection from mirrors and the instrument is therefore less likely to be broken and the adjustment is permanent. The prism A which deviates the ray 90° is used in connection with the open space below it for laying off the perpendicular to the line joining the position of the observer and the distant object. The prism B deviates the ray $88^{\circ}51'15''$ and fixes the point of second coincidence at the end of the base. The prism C deviates the ray $74^{\circ}53'15''$ and is used as an auxiliary to the others in cases where the base is by reason of obstacles difficult of measurement. Its use under such circumstances is illustrated in Fig. 4, Plate 3. The point D having been determined move in prolongation of the line AD until the point B is reached where C viewed through this third prism and A seen directly, coincide. The triangle CDB will then have the following angles.

$$CDB \ 91^{\circ}8'45''$$

$$DBC \ 74^{\circ}53'15''$$

$$BCD \ 13^{\circ}58'$$

and the following proportion results:

$BD : DC :: \text{Sine } 13^{\circ}58' : \text{Sine } 74^{\circ}53'15'' :: 1 : 4$ or
the measured distance BD is one fourth of DC or one two-hundredth of CA.

The Penta Prism Range Finder is the best type of what may be called the compound prism type. The problem solved is again Problem 2, and the method of

solving it the same as that already described for the Pratt and Weldon range finders. This instrument which is shown in its actual size in Fig. 4, Plate 1, has the advantages of being very easily carried and being of permanent adjustment. It is a six sided prism enclosed in metal on top and bottom and on the faces except KF, FG, and GH, Fig. 5, Plate 1, which shows the prism itself without the case. The faces KL and HB are silvered. The face HG if extended would form with KF an angle of 90° and the face FG makes with KF an angle somewhat greater than 90° . The small metal slide shown under R, Fig. 4, always covers either FG or GH and it is for this reason that we speak of it as a compound prism, the result of using one of these faces at a time being the same as if we had two prisms similar in every other respect except that one had for the face at the bottom of the figure the line FG prolonged until it met BH and the other the line HG prolonged until it met KF.

A ray from the range pole entering the prism normal to the face FK in such a position that it emerges through the face GH undergoes only double reflection at the two silvered faces, is not refracted and is deviated 90° from its original direction. If it enters similarly in such position as to emerge through the face FG it again undergoes double reflection and is parallel to the first described ray up to the point of emergence. There it is not normal to this face and is refracted, the angle of the face being such that the ray is deviated $88^\circ 51' 15''$ from its original direction. Should the entering rays not be normal to FK, that first described will be refracted on entering the prism then doubly reflected and again refracted on emerging but the face GH being perpendicular to FK, the refraction at emergence will balance that of entrance and the deviation will be the same as before, 90° , while with the second described ray the refraction on

emergence will differ from that of entrance by a constant amount due to the angle of the face FG and the deviation will again be the same as in the first case, $88^{\circ}51'15''$.

With any of the fixed angle range finders the base may if desired be ranged in by direct vision while viewing the distant object by reflection. By reversing the instrument the right angle may be laid off either to the right or to the left of the observer.

With any of the *fixed angle* range finders the distance between two distant inaccessible points may be readily determined. Let C in Figs. 1, 2, and 3, Plate 3, be the observer's position and let A and A' in the same figures be the two distant points between which the distance is desired. First range on A and mark the point D at the end of the base CD; then range on A' and mark the point D' at the end of the base CD'. Measure the distance DD' between the two marked points and multiply it by the multiplier of the range finder. The result will be equal to the required distance AA' between the two distant points. For, in the triangles CDD' and CAA' the angles DCD' and ACA' are equal and

$$CD:CA :: CD':CA' :: DD':AA'.$$

The base must always be laid off in the same direction, that is, always to the right or always to the left when facing the distant point, and the origin of each base must be at the same point C. For, in Fig. 1, Plate 3, if the base for A had been laid off to the left and marked at D'' and that for A' had been laid off to the right and marked at D' the resulting triangle D''CD' would not be similar to the triangle ACA'.

Any number of points may, like D and D', be marked on the ground corresponding to the base ends for a number of selected distant points, and for any two such marked points the measured distance multiplied by the multiplier of the range finder will

give the distance between the two corresponding distant points. In fact, in marking on the ground the base ends for the selected distant points, those distant points have been plotted on the ground to a scale whose R. F. is 1 divided by the multiplier of the range finder. The plot is oriented at an angle of 90° with the true directions of the distant points. If the multiplier of the range finder is 50, the scale of the plot is 1-50 and any distance measured on the plot is 1-50 of the distance between the corresponding distant points.

With a range finder having a *constant base* the distance between inaccessible points may be determined as follows. Having determined the ranges to the distant points from a common origin, measure off from that origin toward the distant points, 1-50 of the corresponding ranges. The distance between the points so determined will be 1-50 of the distance between the corresponding distant points.

In order to obtain results that are even approximately correct, a range finder must be used with the greatest care and accuracy. The errors that arise may be instrumental or personal. Instrumental errors are due to inaccurate grinding of prisms or to incorrect setting of mirrors. Therefore each range finder should be carefully tested by several trials on accurately measured ranges. This test will determine the correct multiplier and it is better to determine this multiplier than to try to adjust the instrument to an assumed multiplier.

Personal errors arise in ranging out the base, in keeping on range while sighting through the instrument, in sighting at exactly the same point from both ends of the base, and in measuring the base.

To show the effect of these errors assume that a fixed angle range finder with a multiplier of 50 is used on a base of 100 feet to determine a range of

5,000 feet. If the center of the range finder is held only two inches toward the rear side of the perpendicular base line when coincidence is secured, the error in the length of the base will be 10 feet and in the range 500 feet. If, instead of sighting at exactly the same distant point from the two ends of the base, the second point sighted at be only one foot to one side of the first point, the error in the determined range will be 50 feet. An error of one foot in measuring the base also will introduce an error of 50 feet in the determined range. All of these sources of error must therefore be carefully guarded against and only approximate results can be expected even with the greatest care. Other things being equal, the smaller the multiplier of the instrument the greater will be its accuracy, but to offset this advantage, longer bases must be used.

In measuring distances with the range finder, the work can be done more rapidly if the observer has an assistant to help in ranging out the perpendicular and in measuring the base. With the mekometer two observers are necessary. It would seem that two observers might work simultaneously with two fixed angle range finders, the first observer using the right angle and ranging in the second while the second would use the oblique angle and move back on the perpendicular till coincidence of the distant point and the instrument of the first observer is attained. In this case however, as with the mekometer, it is not always certain that the two observers are sighting at the same distant point, and with fixed angle instruments it is probable that the angles of two instruments will not be exactly alike, although their multipliers may be the same.

With the fixed angle instruments greater accuracy may be attained by using the oblique angle at both ends of the base. This doubles the length of the

base, but halves the multiplier, and the errors in ranging will also be halved. The only objection to this method is the greater length of base required. The distance actually determined is that from the middle point of the double base to the distant point, but if the multiplier is 50, the distance from either end of the double base exceeds this by only 1 in 5,000, and this error may be neglected. In fact, the determined range may be taken as the distance from any point at the base to the distant point.

An observer working alone will save time by using a range pole for marking the perpendicular instead of using some distant point more or less plainly defined. He can sight through the right angle prism and note where the perpendicular will fall and then place a range pole as nearly as possible on this line. Returning then to the station and sighting this pole through the instrument if its apparent direction does not coincide exactly with the distant object he can secure such coincidence by moving the original position of the station pole a little backward or forward. In Fig. 6, Plate 1, C is the original position of the station pole. In placing the other pole the observer puts it at E' when its true position would be at E. Sighting it through the instrument its apparent position does not coincide with A but with A'. If, however, he moves to C' the pole at E' and the point A will coincide. The distance as observed from C' can of course be corrected but the error CC' will probably not be more than a few steps which error will be small enough in this system to be neglected. The observer using the other angle then moves to the right sighting the two poles set through the instrument and keeping them covering until he establishes coincidence with A. He will find it convenient to use a third pole against which to steady the instrument in sighting. Having established coincidence he plants

this pole and if he has one end of a tape fastened to the station pole can easily measure the base without assistance.

Theoretically the accuracy of all rangefinders is inversely as their multipliers. Practically the accuracy of any range finder depends on the care and precision with which it is used and on the previous practice that the observer has had. With the fixed angle range finders errors less than three per cent cannot be expected. With constant base range finders the errors will be small for short ranges and large for long ranges.

CONTOURING WITH THE SCALE OF HORIZONTAL EQUIVALENTS.

It may be assumed without argument that maps for military purposes not showing the configuration of the ground are, except for very special and limited uses, practically valueless.

In an earlier part of the course in working with instruments of precision it has been shown how a map may be contoured by determining the elevations of all controlling points and interpolating contour points between such determined elevations. Such a system is, however, manifestly impracticable, in the rough and hurried methods of making road and position sketches in time of actual hostilities.

For such work the Scale of Horizontal Equivalents is used; what is called the horizontal equivalent being the map distance between contours for a given scale, vertical interval and slope. It is the actual map distance and is graphically expressed in such terms. For instance working on a scale of 3 in = 1 mile, after the number of feet for any given slope and vertical interval is found by substituting proper values in the formula $H. E. = \frac{V. I. \times 57.3}{S}$ such distance is not laid off with the scale of the map but a line of the proper length to represent that number of feet to the scale of the map is drawn and marked S° , S° being the slope substituted in the formula to determine that particular length.

(In the remainder of this article the words "horizontal equivalent" will be expressed by the letters H. E.)

The scale may be constructed by working out the successive lengths from one degree up to the number of degrees representing the steepest slope usually

encountered in actual work, about twelve degrees, and laying them off on a line one after the other from left to right. For determining the H. E. of slopes not expressed in even degrees it is better to lay off the successive values on perpendiculars at regular intervals from an origin and to construct the curve through the ends of the perpendiculars. Then, measuring the ordinates to the curve from properly proportioned distances between the degree marks, the H. E. for any degree and part of a degree can be readily determined. This method of construction is shown in Fig. 5, Plate 4. If the construction be made on cross section paper allowing sixty small spaces between the points from which the ordinates for whole degrees are drawn, the scale can be read to single minutes and can be used for plotting the observations made with the most accurate instruments. Care should be taken to determine from the formula the length of enough ordinates to accurately establish the curve.

However as will be shown in actual work with this scale it is desired to apply it to a plotted line of known slope and to ascertain how many contour intervals and parts of such intervals are contained in that line. So, it is desirable to have a number of horizontal equivalents for the same slope arranged side by side along a line. This construction which renders the use of dividers unnecessary, is shown in Fig. 4, Plate 4, and is the best form of the scale yet devised for field work.

Using the scale of H. E., the location on a line of known slope of the points where contours cross is just the reverse of the process of determining the elevations of the ends of the line and interpolating between them. With the scale H. E., of the contour points are first determined and from the number of contour intervals and the remaining part of an in-

terval, if there be any, between the ends of the line, the difference of elevation is determined. For example the horizontal projection of a line joining two points has been plotted and its slope ascertained to be $+3^\circ$. Assume that the station at the beginning of the line is the first station of the survey and has an elevation of 800 feet and that the vertical interval is 20 feet. Apply the scale of H. E., for 3° . It is found that the equivalent is contained in the line four and one half times. The elevation of the far end of the line is therefore 890 feet. Should the beginning of the line not be at the elevation of a contour, the fractional part of the equivalent representing the difference between the station elevation and the next higher or lower contour would first be applied to find the first contour point, then the full intervals that are contained in the line would be plotted, and then if there was still room for part of an interval it would be determined what fractional part of the H. E. such distance represented and the exact elevation of the forward station found.

By such means the contour crossing points and the elevations of all points connected by lines of measured length and slope can be quickly determined, On offset lines the slope of which is uniform within the limits of the map the contour points can be plotted without measuring the lines, only their slopes and directions being required. When the positions and elevations of distant points have been determined and it is known that the slope between them is uniform, the contour points can be plotted by interpolation between these elevations, After the necessary contour points are plotted the contours are drawn in the usual manner.

The lines along which the slopes are determined are selected with a view to giving the maximum information as to the direction of the contours. The

principles governing the selection of these control lines and points are the same in this method as in the one already studied. Water course and water shed lines give the best control.

In measuring slopes in road and position sketching the sketcher who has previously done only precise work on a large scale will have to revise his ideas as to the degree of irregularity to be considered. In road work, for example, with a scale of 3 in.=1 mile it is useless to measure every little hill or depression. The thing to consider is whether such irregularity will make a change in the direction or spacing of the contours that can be made apparent with the working scale. In general it will be found that slopes should be averaged as if absolutely uniform so long as they continue in the same direction, that is, all up hill or all down hill without decided knuckles. When a slope continues up or down hill with about the same angle, only one observation is necessary. If at any point it changes to a generally steeper or gentler slope, then the angle of the new slope must be measured. Such an example is frequently met with where a hill near the bottom, after sloping down at about the same average, changes at an easily recognized point to a much gentler slope; or in going up a hill there is frequently near the top a point where the slope very perceptibly flattens out. All such changes should be noted and of course all changes from a down hill to an up hill slope. The *principle* is exactly the same as in running an accurate profile with a scale of say 1 in.=100 ft., but changes that may easily be shown on such a scale would be inappreciable in a road map where a line representing a certain distance would be only about one-eighteenth as long as in the first case. It would be impossible to crowd into one inch all the details that might be shown in a space of 18 inches.

While, then very considerable latitude in averaging slopes is not only desirable but necessary in sketching on a small scale, this latitude does not extend to the omission of such observations as are necessary for showing ground cover for a considerable body of men in the vicinity of a road that is being sketched, or such as are necessary for locating dead angles in a position sketch. And it must be borne in mind that as the scale increases, particularly when the vertical interval is decreased in consequence of such change, measurements for slopes must be more carefully made. A vertical interval of five feet will show the configuration of the ground much more accurately than one of twenty feet, provided the work is done with proportionate increase of care. But five foot contours obtained by interpolation between twenty foot contours, while they may be of assistance in working out plans on the map, afford otherwise no increase in information.

The different methods of sketching contours with the scale of H. E. may be best explained by reference to figures. As many typical cases as possible will be shown and a thorough understanding of these should enable the sketcher to solve any other problem which may arise even though it is not specifically mentioned.

The upper half of Plate 4 is designed to show the general method of contouring a road sketch. The solid line along the middle of the plot represents the road, the small circles the stations occupied by the sketcher and the dotted lines parallel to the road the limits on each side of the route to which it is desired to carry the work. These limiting lines refer only to the general detail, but points of importance such as nearby villages or farms, hills, positions for an enemy, camping grounds, etc, would still be shown although outside these limits. However the

lines will be considered as limiting the sketch under ordinary conditions. It is well to keep these limits in view as far as contours are concerned, for the slope of any line uniform within these limits may be measured and the contour points plotted without measuring the distance, while the distance to each change of slope not uniform within these limits must be measured.

Starting at Sta. 1, the elevation of which is unknown, but is assumed to be 500 feet, first plot the direction of the forward course, and measure and mark on the plot its slope, $+2^\circ$. Then measure the slopes on rectangular offsets, right -2° , left $+3^\circ$. The slopes on these offsets are uniform within the limits of the map, therefore the distances on them are not measured. Measure the distance along the forward course. When the water shed is reached stop and plot the position of Sta. 2. Plot the direction to right and left of the axis of water shed. That to the left has a uniform slope to A and then changes. Measure slope and distance to A. Beyond A, the slope being uniform to the limits of the sketch, measure the slope only. To the right only the slope need to be measured. Now, with the scales of H. E. plot contour points along main course and the offsets, giving to each point established its proper contour elevation. The number of intervals from Sta. 1 to Sta. 2, gives the elevation of Sta. 2 and therefore a new origin of heights for lines drawn from Sta. 2. Draw the contours through the proper points as indicated by the elevations. In case only a single point is determined for any contour its direction will have to be assumed from adjoining contours more definitely located.

Plot the direction and slope of the forward course and measure along the same. Before reaching Sta. 3, the slope on the course changes and this

change is at the bottom of a water course. Plot the position of this change at B and take offsets to right and left along the axis of water course. The offset to the left changes slope at C and a measurement to that point must be taken. The new angle of slope on main course is observed and the measurement continued to the end of course and Sta. 3 is plotted. This is on a water shed and offsets are taken along its axis. Both slopes are uniform within the limits so no distances are measured. Now plot contour points along main course and determine elevations of B and Sta. 3. Then plot contour points along offsets and complete the contours as far as possible.

Plot the forward course and slope, measure the distance and plot Sta. 4. As there is no directing water course or water shed at this point, take the offsets at right angles. When the contour points along the course are plotted it is found that from the last contour point to the end of the course an interval of one half the H. E. is left. This means that Sta. 4 is one half the vertical interval, or ten feet lower than the last contour crossing the line and its elevation is so marked. In plotting along the offsets start out first with half of the H. E. for the respective slopes to reach the next higher or lower contour. If this left over fraction were $\frac{3}{4}$ of the H. E. the elevation of Sta. 4 would be 505 feet, and in plotting on the left hand offset, $\frac{3}{4}$ of the H. E. for $1\frac{1}{2}^\circ$ would first be used to get up to the 520 contour. On the right hand offset and on the forward course to Sta. 5, only $\frac{1}{4}$ of the H. E.'s. for the respective slopes would be first used to get down to the 500 contour.

The remainder of the sketch shows no points not already brought out. It will be seen that there is little information as to some of the contours, but that some of them have a sufficient number of points to establish their position very definitely, so that they

serve as directing lines for the others. The contour plotting should be kept up with the forward progress, for, while the contour directions are worked out by the location of the points at which they cross the controlling lines rather than by any effort of the sketcher to keep track of them on the ground, still the finishing of the contours while the sketcher can compare the result with the ground they are intended to represent, minimizes the chance of any very great errors or absurdities due to lack of sufficient control.

Fig. 2, Plate 4, shows how contours may at times be located when it is necessary for proper control to run a line along which it may be difficult to determine direction or slope on account of heavy woods. The general axis of the feature crosses the road at A but it is hard to follow its general direction. A clear sight may be had to the axis from C. The direction and distance of CB is measured and A and B are joined. If satisfactory observation of the vertical angle could not be made from A, the slope may be measured on an imaginary line joining C and B. Using the scale of H. E. on the projection of this line the elevation of B is determined. Contour crossings are then plotted on line AB by interpolation.

In the case of a water shed or water course within the limits of the sketch, the axis of which does not cross the main traverse, an offset AB, Fig. 3, Plate 4, is measured, the slope of an imaginary line joining A and B is measured, and elevation of B determined. Then at B, make the necessary observations on the line BC.

It is necessary always to know the elevation of any point from which a vertical angle is measured for determining contour points. This can always be determined by the use of the scale of H. E. if the angle and distance from a determined to an undetermined point be measured, even though the ground is not

uniform between the two points. When these observations are made along an air line without reference to the ground between the two points, care should be taken not to confuse intermediate elevations used in finding the elevation of the point with elevations on the ground through which to draw contours.

Several typical cases of such determinations of elevation will be explained under position sketching in which work they are more apt to be met with than in road sketching.

The principles involved in contouring position sketches with the scale of H. E. are exactly the same as those already explained for road sketching. The work, however, presents some typical features more often met with in this work than in road sketching. As the limits are greater, distances will more frequently have to be measured. The scale used is generally larger and a corresponding increase in accuracy in measuring slope angles is necessary.

The map on Plate 3 represents a position sketch contoured with the scale H. E. In this particular sketch all the observations have been made from the two stations A and C and the measurements necessary to determine the indicated distances are presumed to have been made with a range finder.

The observer first occupies the station at A and plots the line to D at the point where the stream empties into the lake. The slope is uniform. Assuming the elevation of the lake to be zero, the contour points are plotted starting from D. This brings the remaining fractional part of the H. E. at the station end of the line and gives the elevation of A 145 as compared with the lake. Another measured line is plotted to the lake to establish the location of the shore line. The line AC is on a slope very steep to B, less so to C and there changing to a very gentle

slope. The profile on this line is shown in Fig. 6, Plate 3. The vertical angle is measured on the line AC, and, using the scale on the line A'C, the horizontal projection of the measured distance, the elevation of C is determined. The vertical angle and the horizontal distance to B are then measured and, on the line A'B', the contour points are plotted and the elevation of B is determined. Between the map positions of B and C, the elevations of which points are now known, the contours are plotted by intopolation.

After completing the work on this offset angles and distances are measured on the two short offsets to the right and on the one toward the upper left hand corner of the map. These are all taken to the foot of the uniform slope.

The profile on the line joining A and C is shown in Fig. 5, Plate 3. Measure the vertical angle and distance to C on the line AC. Apply the H. E. for the observed angle to the line A'C', (AC on the map) and from the known elevation of A determine the elevation of C. From A measure the angle of slope to the bottom of the col and from C measure the angle to the same point. Plotting the contour points on both of these lines gives both positions of the first contour above the bottom of the col. It is not necessary to measure the distance to the low point B unless the elevation of B is desired.

From C starting with the offset to the right of CA and going around contra clock-wise, the first offset to the foot of the uniform slope must be measured. On the next three offsets the slopes are uniform within the limits of the plot and no measurement of distance is necessary. The next offset is to a point on the stream and its length must be measured. Having two points on the stream and being able to see that it is practically straight between them it is drawn in without further location. The distance together

with the slope determines the elevation of E. The stream is assumed to have a uniform slope and its contour points are determined by interpolation between the known elevations of D and E.

The last offset is a measured one to the foot of the uniform slope.

THE COMPASS.

The compass is one of the simplest and most convenient of instruments for measuring horizontal angles. Its principal advantage over other angle measuring instruments lies in the fact that it is always oriented. Its principal defect is that the orientation is inaccurate and varying, so that generally certain allowances or corrections must be made.

Referring to the parts which have been mentioned as essential in angle measuring instruments, there are found in the compass :—

1. The pointers or sights which fix the particular line of the instrument that is brought into coincidence with the line of sight in the required direction.

2. A graduated circle upon which the direction of the sighting line is given in degrees of arc from the standard direction which is indicated by:—

3. The magnetized needle which is balanced on a pivot at the center of the graduated circle, and which always lies in the magnetic meridian.

4. Various means are provided for making the graduated circle horizontal. Some compasses have leveling screws and plate levels like the transit; others have a ball and socket joint and plate levels, and others are simply held horizontally in the hand.

5. The several parts of the compass are assembled in a case or box, which is held in the hand if it is a pocket, box or prismatic compass, and is mounted on a tripod or Jacob's staff if it is a surveyor's compass.

There are two general classes of compasses, known as *needle compasses* and *card compasses*.

In the needle compass the graduated circle is attached to the box or plate and turns with the sights or pointers. In this case the index is the *north end* of the needle which remains fixed while the graduations of the circle pass by it.

In the card compass the graduated circle is marked on a circular card or on a light ring of metal which is attached to the needle and which therefore remains fixed while the index which is marked on the box turns with the sights or pointers.

These two methods of reading angles may be compared with the two methods applied in reading the vertical and horizontal circles of the transit. The vertical circle of the transit turns with the telescope, while its index and vernier remain fixed. So, in the needle compass, the circle turns with the sights while the index or needle point remains fixed. The horizontal circle of the transit remains fixed while the index and vernier on the upper plate turn with the telescope. So, in the card compass, the graduated circle remains fixed with the needle while the index on the box or case turns with the sights.

From these two methods of reading angles there result two corresponding methods of graduating the circular arc. All compasses should read zero (or 360°) when the sights point north, 90° when the sights point east, 180° when the sights point south and 270° when the sights point west. In the needle compass remember that the index or north end of the needle remains fixed while the graduations of the circle pass by it. Then in turning from north, zero, to east 90° the numbers of the graduations must run toward the left, contra-clockwise, and so on all around the circle; that is, the graduations must be numbered in a direction (left) opposite to the direction in which the angle is turned or measured (right).

In the card compass the circle, attached to the needle, remains fixed while the index with the sights or pointers turns past the graduations. Therefore in turning from the north, zero, to east, 90° , the numbers of the graduations must run to the right or in clockwise direction. That is, the graduations must be numbered in the same direction (right) as that toward which the angle is turned or measured (right).

Unfortunately, compasses are not all graduated in the manner indicated above. Some are numbered from zero at the north and zero at the south, both ways to 90° at the east and 90° at the west. The same numbers are therefore found in each of the four quadrants and in recording a bearing it is necessary to add the letters NE, SE, SW, or NW, in order to designate the quadrant, thus N 25° E, S $47^\circ 30'$ E, etc.

Others are graduated from zero at north, east, south and west to 45° at northeast, southeast, southwest and northwest, and in this case the letters indicating the octant must be added thus W 28° N, S 14° E, E 44° N, etc.

Some are graduated from zero at the north in both directions to 180° at the south and the letter E or W must be added to indicate the semicircle in which the angle is read.

There will also be found compasses numbered to read zero for a north pointing, 90° for a west pointing, 180° for a south pointing and 270 for an east pointing.

When a choice can be made, a compass numbered continuously from zero to 360 degrees, and reading N, 0° ; E, 90° ; S, 180° ; W, 270° , should be selected. An officer may, however, find that the only compass available is marked by any one of the systems mentioned and he should be able to use it and to record and plot its bearings.

THE PRISMATIC COMPASS.

The prismatic compass is a card compass with front and rear sights, the rear sight having an attached magnifying prism which reflects an image of the graduated edge of the card into the eye when a sight at the distant point is taken.

With any other form of the compass, the sighting line must first be pointed at the distant object and then the compass reading be made, but with the prismatic compass the graduated circle is read simultaneously with the pointing of the sights.

The index of this compass is the rear sight and since it is desired that the compass read zero when pointing north, 90° when pointing east, etc., the zero should be placed at the south of the card, 90° at the west of the card, 180° at the north and 270° at the east.

The mirror in the prism reverses the image of the graduation marks and the numbers on the card must therefore be printed in reversed form like the face of the printer's type, in order that the mirrored image may be direct.

The prismatic compass is the most accurate of the hand compasses and is a valuable instrument for rough surveying or careful sketching.

THE BOX OR MILITARY COMPASS.

This is a simple needle compass mounted in a rectangular block of wood with a hinged cover. In some, the edge of cover when raised to a vertical position is the sighting line, and in this case, holding the cover toward the right, the zero should be at the forward side, the 90° mark at the left, the 180° mark at the near side and the 270° mark at the right.

In another form a white line is marked on the inside of the lid. When the lid is wide open this line is in the prolongation of the 0° — 180° line of the com-

pass. To point the compass, open the cover about 120° and turn it to the front. Hold the compass level and a little below the eye. The white line will be seen reflected in the glass top of the compass. Make this reflected line coincide with the 0° — 180° line of the compass and while maintaining this coincidence sight over the top of the white line at the distant object. When the needle comes to rest read its north end.

Many forms of pocket compasses are manufactured, but they are generally unsuitable for surveying or sketching. For these purposes a needle compass should have the the following features:—

1. A good sighting line.
2. A light, sensitive needle with a stop.
3. A raised circle lying in the same plane with the ends of the needle.
4. Plainly marked graduations dividing the circle into single degrees and numbered continuously from zero to 360° in contra-clockwise direction. The 0° — 180° line should be parallel to the sighting line, with the zero at the forward side.

5. A strong, water-tight case.

For the card compass the requirements are the same except that the graduated circle is marked on the card, the numbering should be in clockwise direction, and the index should be so placed as to read zero when the sights point north.

TO PLOT THE BEARINGS GIVEN BY A COMPASS.

A protractor is a flat piece of metal, paper, wood, celluloid or other material, near the edge of which are radiating lines spaced at degree or half degree intervals. The center point from which these lines radiate is also marked, and the degree marks are numbered, usually at 10° intervals, to facilitate counting.

To plot any angle at a given point on a given line, place the center mark of the protractor at the given point, and the zero line of the protractor on the given line. Count the degree marks in the desired direction to include the number of degrees in the given angle and mark a dot on the paper at the point so determined. A line drawn through the center point and the dot so marked will make with the given line the given angle.

In plotting compass bearings the given point is the station point on the paper and the given line is the meridian line drawn through the station point. The angle laid off is the angle expressed by the compass bearing.

It has been explained that compasses are graduated and marked in several different ways and that the same direction with reference to the meridian may be expressed by a number of different compass readings, depending on the kind of compass and the manner of its marking. In order therefore to plot the bearings given by any particular compass, the protractor should be marked or numbered to correspond with the *readings* of the compass. This does not mean that the protractor should be marked like the circle of the compass used, but rather that it should be marked to give the same *readings* as the compass.

For example, a needle compass, like the box compass, that reads zero when pointing north, 90° when pointing east, 180° when pointing south and 270° when pointing west, is graduated to the left or contra-clockwise and has the zero mark at the forward side, the 90° mark at the left, 180° at the near side and 270° at the right, whereas a prismatic compass that gives the *same readings* would be graduated to the right or clockwise, and would have the zero at the south point of the card, 90° at the west point, 180° at the north and 270° at the east.

For both of the compasses just described the markings of the protractor should be the same and should be numbered in clockwise direction from zero to 360° , and the zero mark should be placed toward the north end of the meridian when the center mark is at the station point.

The rule to be followed for determining the proper marking of a protractor to correspond with any compass is as follows:—

Point the sighting line of the compass to the north and read the compass. Mark this reading on the protractor at the north end of the diameter that is to be placed in coincidence with the meridian line on the plot. Next point the compass to the east and read it. Mark this reading on the protractor at a point 90° to the right of the north reading. Then point the compass to the south and read it. Mark this reading at the south end of the meridian diameter of the protractor. Lastly, point the compass to the west and read it. Mark this reading on the protractor at a point 90° to the left of the meridian diameter. Mark also the intermediate points of the protractor at 10° (or 5°) intervals to correspond with the intermediate compass readings. The protractor will then plot, without reduction, the recorded readings of the compass.

If the protractor has been marked by the maker with numbers that do not correspond with the compass used, it is only necessary to disregard those numbers and mark the proper numbers with pencil or ink. Conversely, if the compass is not marked in the desired manner, new numbers may be added and the old ones disregarded.

A *plotting diagram* for any compass consists of two lines crossing at right angles, and marked at their ends with the N, S, E and W, *readings* of the compass. It indicates the proper markings of the

protractor to be used with that compass. The figures on Plate III give the compass graduations and corresponding plotting diagrams for four compasses, the first two being box or needle compasses, and the other two being prismatic or card compasses. For any other compass, the plotting diagram would be constructed in a similar manner.

In military topographic sketching it may be necessary for compass notes taken by one person to be plotted by another. Even when the sketcher plots his own notes he may be working with a compass furnished him for the particular occasion and differing in its marking from the one he is accustomed to using. To remove all chance of error a plotting diagram of the compass used should be placed at the beginning of every set of compass notes.

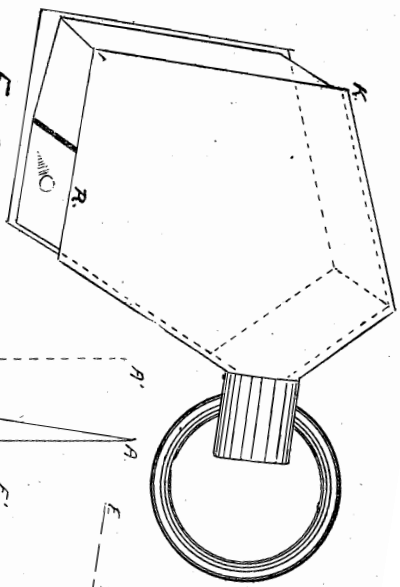

FIG. 4.

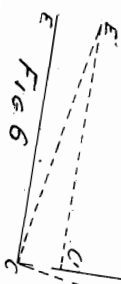

FIG. 6.

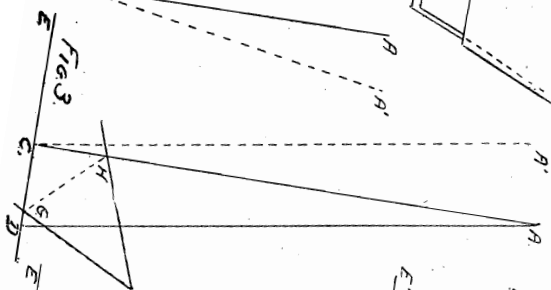

FIG. 3.

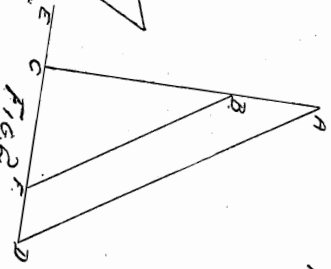

FIG. 2.

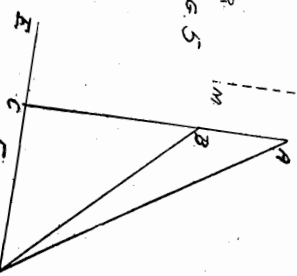

FIG. 5.

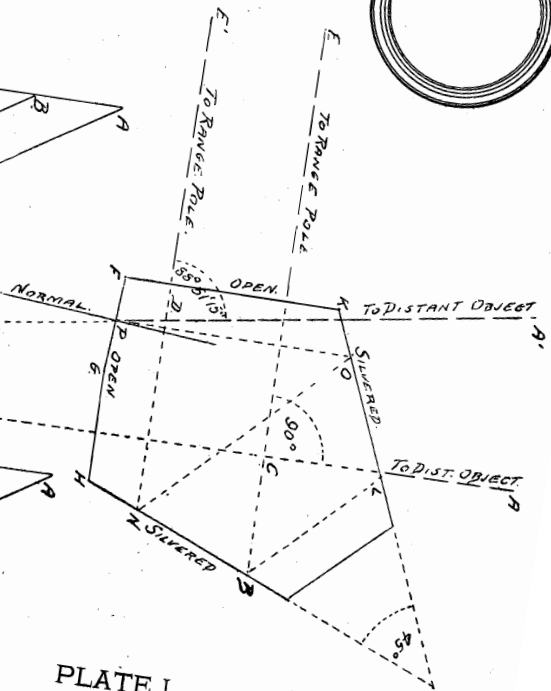

PLATE I.

PLATE II.

Fig. 1

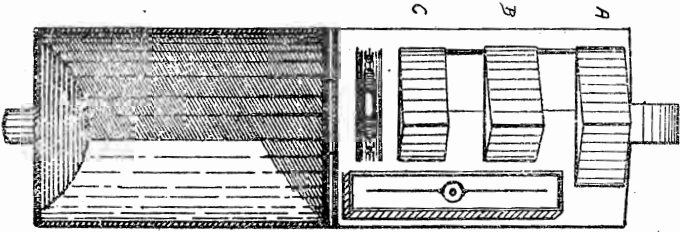

Fig. 2

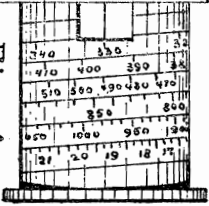
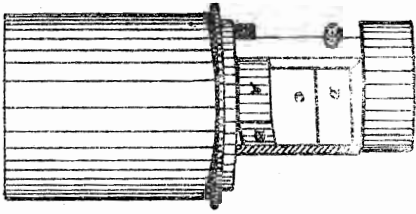

Fig. 4

Fig. 3

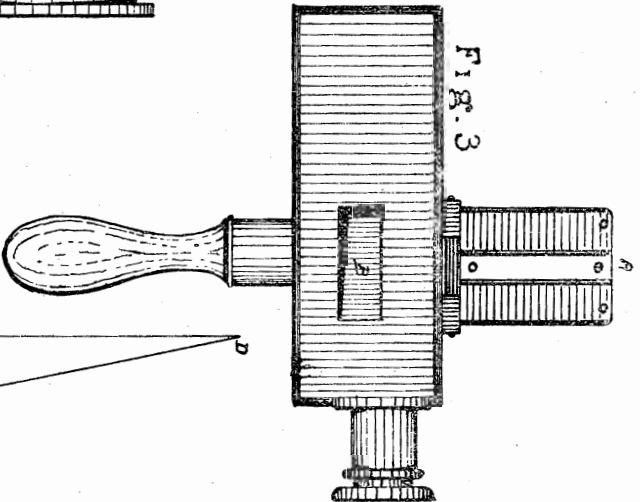
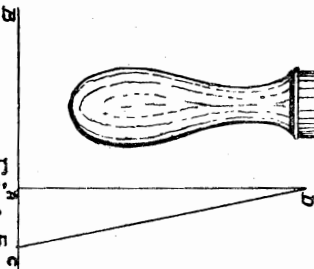
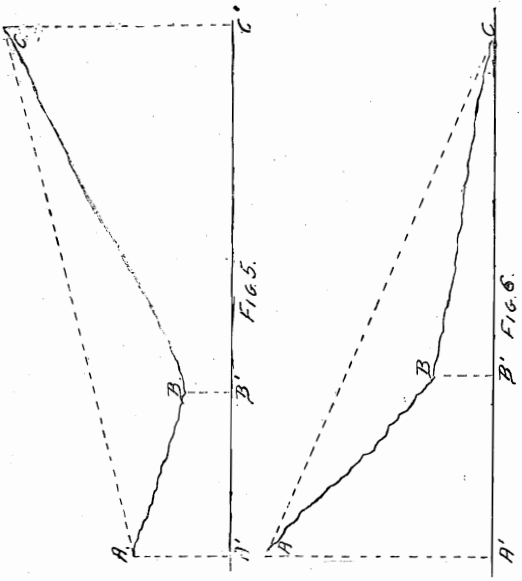
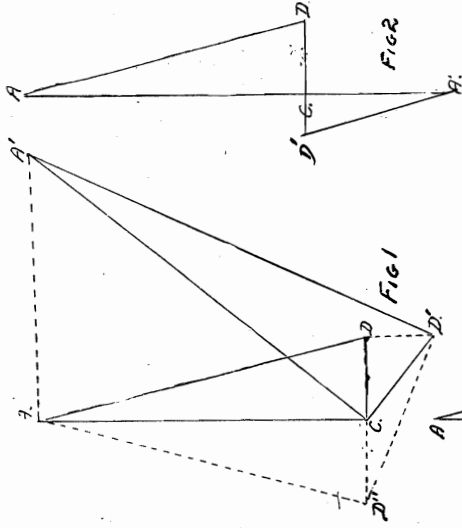
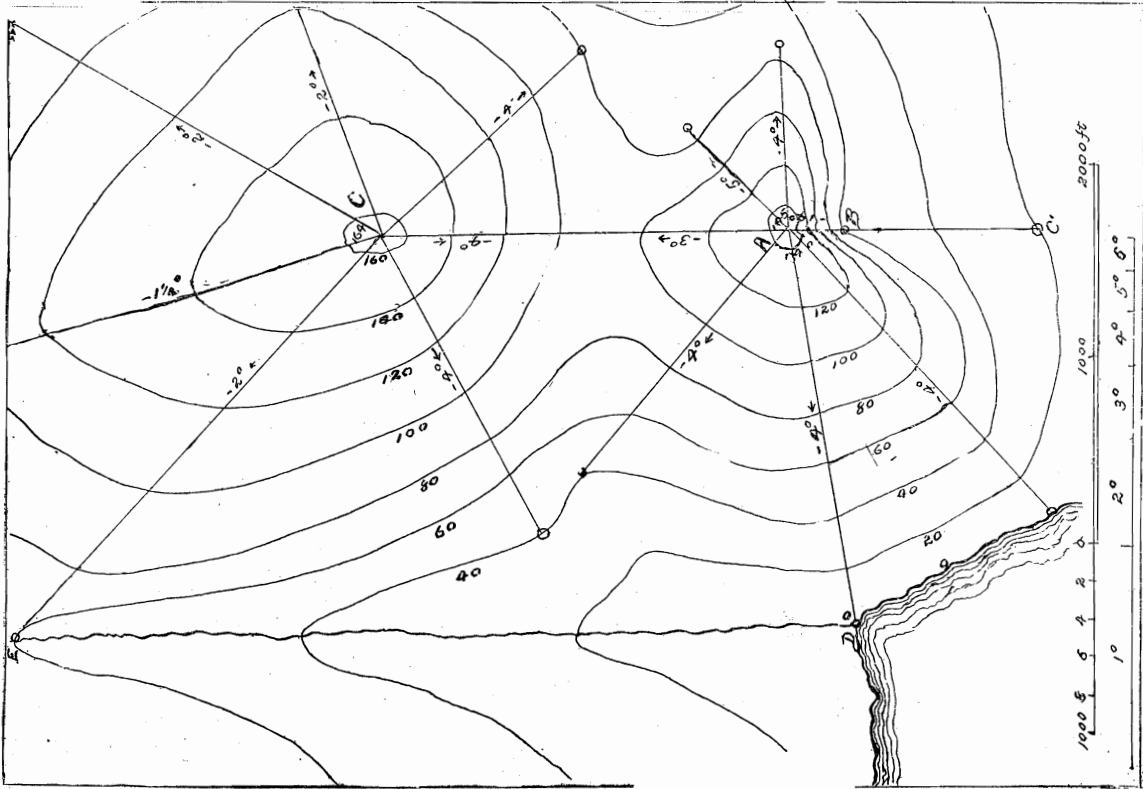

Fig. 5





COMPASS GRADUATION

BOX COMPASS.

PRISMATIC COMPASS.

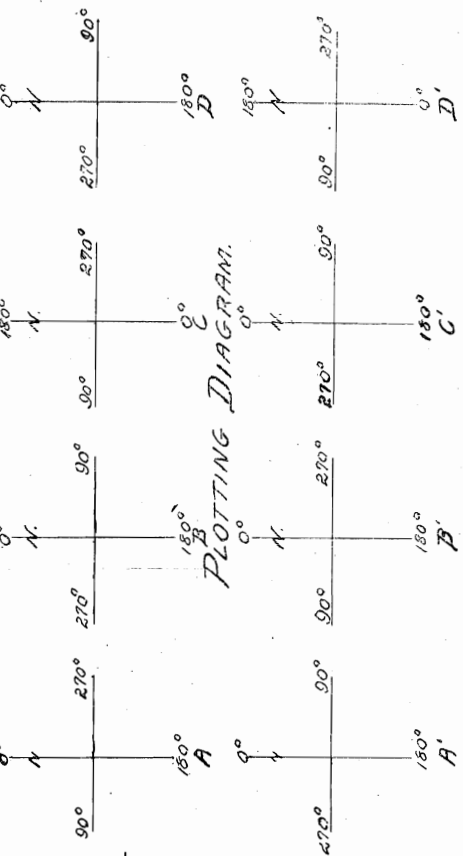

SCALE 3 IN = 1 MILE - V.I. 20 FEET

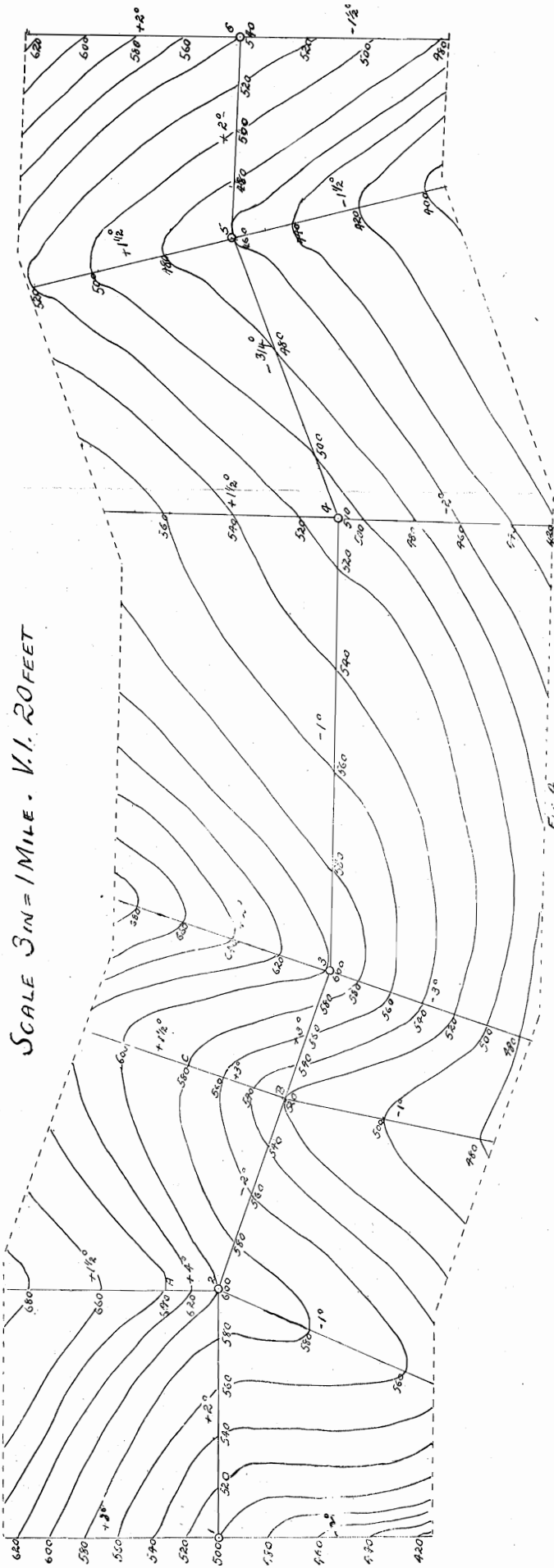

Fig 4

SCALE OF SLOPES		FOR	
INCHES TO MILE	1/2 3/4 1 1 1/2 2 2 1/2 3 4 5 6 7 1/2	8	10 12 15 20 24 30 40 60 80 120
V.I. IN FEET	120 80 60 40 30 24 20 15 12 10 8	7 1/2	6 5 4 3 2 1 3/4 1/2
INCHES TO MILE			
V.I. IN FEET.			

Fig 5

1/2	3/4	1	1 1/2	2	2 1/2	3	4	5	6	7	7 1/2	8	9	10	11	12
-----	-----	---	-------	---	-------	---	---	---	---	---	-------	---	---	----	----	----

