

# The 2012 ATP® Official Rulebook



Copyright © 2012 by ATP Tour, Inc.  
All Rights Reserved.

Reproduction of this work in whole or in part without the written permission of the ATP Tour, Inc., is prohibited.

Printed in the United States of America.

## TABLE OF CONTENTS

<b>I. ATP CIRCUIT REGULATIONS .....</b>	<b>7</b>
1.01 Categories of Tournaments .....	7
1.02 Tournament Week .....	7
1.03 Match Schedule Plan .....	8
1.04 Finals Options .....	8
1.05 Change of Tournament Site.....	9
1.06 Commitment to Rules.....	9
1.07 Commitment, Membership Obligations and Bonus Pool.....	9
1.08 Reduction of ATP World Tour Masters 1000 Commitment .....	12
1.09 Unsatisfied Player Commitment Penalties .....	12
1.10 Mandatory Player Meeting .....	13
1.11 Player Eligibility/Player University/Physical Exam .....	13
1.12 Waiver of Claims .....	13
1.13 Waiver/Player Publicity and Promotion .....	14
1.14 Stars Program .....	14
1.15 Special Events - Exhibitions .....	15
1.16 Promotional Fees .....	16
1.17 Electronic Insertion.....	16
1.18 Non-Exclusive Media Highlight Rights. ....	16
1.19 Quality/Broadcast .....	16
1.20 Seating and Attendance .....	17
1.21 Hotel Accommodations (Rooms).....	17
<b>II. BRANDING .....</b>	<b>21</b>
2.01 Identification - ATP World Tour Tournaments.....	21
2.02 Identification - ATP Challenger Tour Tournaments.....	27
<b>III. FINANCIAL .....</b>	<b>31</b>
3.01 Composition of Commitment .....	31
3.02 Currency .....	31
3.03 Default of Prize Money Payments .....	31
3.04 Fee Obligation .....	31
3.05 Fees/Other Payments .....	32
3.06 Insurance.....	32
3.07 Letter of Credit - New/Conditional Tournaments.....	32
3.08 Prize Money .....	33
3.09 On-Site Prize Money .....	34
3.10 Prize Money / Fee Payments .....	34
3.11 On-Site Prize Money Adjustment.....	34
3.12 Payment .....	35
3.13 Late Payment .....	35
3.14 Taxes-Notice of Withholdings .....	35
3.15 Withholding From Prize Money .....	36
3.16 Prizes and Non-Cash Awards.....	36
3.17 Release from Financial Commitment .....	36
3.18 Tournament Financial Information .....	36

### ATP OFFICES

ATP LONDON	ATP Americas	ATP Europe	ATP Int'l Group
IG House	201 ATP Tour Blvd.	Monte Carlo Sun	Level 2
Palliser Road	Ponte Vedra Beach	74 Boulevard D'Italie	234 George Street
London W14 9EB	Florida 32082 USA	98000 Monaco	Sydney NSW 2000
Tel: +44 207 381 7890	Tel: +1 904 285 8000	Tel: +377 97 97 04 04	Australia
Fax: +44 207 381 7895	Fax: +1 904 285 5966	Fax: +377 97 97 04 00	Tel: +61 2 9250 2300
			Fax: +61 2 9250 2333

**www. ATPWorldTour.com**

## TABLE OF CONTENTS

<b>IV. WORLD CHAMPIONSHIPS .....</b>	<b>39</b>
4.01 Barclays ATP World Tour Finals - Singles .....	39
4.02 Barclays ATP World Tour Finals - Doubles .....	42
4.03 ATP World Tour Team Championship .....	45
<b>V. PERSONNEL .....</b>	<b>53</b>
5.01 Tournament Director .....	53
5.02 Tour Manager .....	53
5.03 PR & Marketing .....	53
5.04 Doctor, Physiotherapist and Massage Therapist .....	54
5.05 Supervisor .....	54
5.06 Chair Umpire .....	56
5.07 Line Umpire .....	59
5.08 Referee .....	61
5.09 Chief of Umpires .....	62
5.10 Ball Persons .....	63
5.11 ATP/ITF/WTA Code for Officials .....	64
<b>VI. FACILITIES &amp; ON-SITE CONDITIONS .....</b>	<b>67</b>
6.01 Courts .....	67
6.02 Match and Practice Courts .....	68
6.03 Balls .....	69
6.04 Crowd Movement / Spectator Seating .....	71
6.05 Security at Tournaments .....	71
6.06 Equipment & Supplies .....	71
6.07 Temperature and Ventilation For Indoor Facilities .....	73
6.08 Offices .....	73
6.09 Communication Devices .....	73
6.10 Tour Identification Card .....	74
6.11 Tournament Credentialing and Ticketing .....	74
6.12 Player Benefits - Guest Passes/Credentials .....	75
6.13 Player Lounge .....	75
6.14 Locker Room .....	76
6.15 Stringing Service .....	76
6.16 Food .....	76
6.17 On-Site Access / Limits to On-Site Access .....	77
6.18 Transportation .....	77
6.19 Player Treatment Room .....	77
6.20 First Aid .....	77
6.21 Anti-Doping Facilities and On-Site Personnel Assistance .....	77
6.22 Media Facilities Guidelines .....	78
6.23 Electronic Line Calling Facilities Guidelines .....	78
<b>VII. THE COMPETITION .....</b>	<b>79</b>
7.01 ATP Fees .....	79
7.02 Entries .....	79
7.03 Entry Deadlines .....	80
7.04 Entry/Withdrawal Method .....	82

## TABLE OF CONTENTS

7.05 Withdrawal/Late Withdrawal Penalties .....	84
7.06 One Tournament Per Week and Exception .....	86
7.07 Play-Up Regulation (ATP Challenger Tour Tournaments) .....	86
7.08 The Draw .....	87
7.09 Size and Method of Draw .....	90
7.10 Special Exempts (SE) .....	92
7.11 Time of Draw .....	95
7.12 Wild Cards .....	95
7.13 Selection of Entries .....	97
7.14 Seeds Definition .....	101
7.15 Number of Seeds .....	102
7.16 Placement of Seeds - Main Draw .....	102
7.17 Qualifying Placement .....	103
7.18 Byes - Assignment and Placement .....	104
7.19 Remake of Draw .....	104
7.20 Lucky Losers, Substitutions and Vacancies .....	105
7.21 Match Scheduling .....	111
7.22 On-Court Procedures and Requirements .....	117
7.23 Line Umpire Requirement Positions and Calls .....	137
7.24 Scoring of Match .....	139
7.25 Announcing .....	140
<b>VIII. THE CODE .....</b>	<b>145</b>
8.01 Tournament Obligations .....	145
8.02 Tournament Violations .....	146
8.03 Player Code of Conduct ("Code") .....	148
8.04 Player Major Offenses/Procedures .....	171
8.05 Uniform Tennis Anti-Corruption Program .....	175
8.06 Final Dispute Resolution .....	185
<b>IX. ATP RANKINGS ® .....</b>	<b>187</b>
9.01 Definitions .....	187
9.02 Eligibility .....	187
9.03 South African Airways ATP Rankings (Singles) .....	188
9.04 ARAG ATP World Team Championship Point Schedule .....	192
9.05 Davis Cup .....	192
9.06 ATP Doubles Rankings .....	193
9.07 2012 ATP Doubles Team Rankings .....	195
9.08 Retiring from the Professional Tennis Circuit .....	195
<b>X. EXHIBITS .....</b>	<b>197</b>
EXHIBIT A.01 - ATP World Tour Official Tournament Stamps .....	197
EXHIBIT A.02 - Size Relationship - Men Only Events .....	197
EXHIBIT A.03 - Size Relationship - Combined Events .....	198
EXHIBIT A.04 - Positioning .....	199
EXHIBIT A.05 - Exclusion Area .....	200
EXHIBIT A.06.1 - Acceptable & Unacceptable Uses - Men only .....	201
EXHIBIT A.06.2 - Acceptable & Unacceptable Uses - Men only .....	202
EXHIBIT A.06.3 - Acceptable & Unacceptable Uses - Men only .....	203

# TABLE OF CONTENTS

EXHIBIT A.06.4 - Acceptable & Unacceptable Uses - Combined .....	204
EXHIBIT A.06.5 - Acceptable & Unacceptable Uses - Combined .....	205
EXHIBIT A.06.6 - Acceptable & Unacceptable Uses - Combined .....	206
EXHIBIT A.07 - Web Site Exhibit .....	207
EXHIBIT A.08 - Scoreboards / Draw Boards .....	207
EXHIBIT A.09 - Leader Boards.....	208
EXHIBIT A.10 - Nets / Net Signage .....	209
EXHIBIT A.11 - Media Backdrop .....	210
EXHIBIT A.12 - Court Surface Color .....	211
EXHIBIT A.13.1 - Court Host Locality - Option 1 .....	212
EXHIBIT A.13.2 - Court Host Locality - Option 2 .....	213
EXHIBIT A.14 - Court Backdrops .....	214
EXHIBIT A.15 - ATP Challenger Tour Brand Mark.....	215
EXHIBIT A.16 - ATP Challenger Tour Website .....	215
EXHIBIT A.17 - ATP Challenger Tour Court Backdrops.....	216
EXHIBIT B - ATP World Tour Logo .....	217
EXHIBIT C - Broadcast Standards .....	219
EXHIBIT D - Attendance Standards .....	223
EXHIBIT E - Electronic Insertion .....	224
EXHIBIT F - Lighting.....	225
EXHIBIT G - ATP Challenger Tour Logo (Print & Promotional Materials).....	226
EXHIBIT H - ATP Challenger Tour Logo (On-Court Version).....	226
EXHIBIT I - Rules of Tennis.....	227
EXHIBIT J - Prize Money.....	262
EXHIBIT K - Schedule of Matches .....	272
EXHIBIT L - Line Umpire Program .....	274
EXHIBIT M - Point Penalty Card .....	277
EXHIBIT N - Scorecard .....	278
EXHIBIT O - Glossary .....	279
EXHIBIT P - Chief of Umpires .....	283
EXHIBIT Q - Special Exempts.....	285
EXHIBIT R - Consent and Agreement Form.....	287
EXHIBIT S - Privacy Notice ("HIPPA").....	289
EXHIBIT T - Player Food Service .....	293
EXHIBIT U - Player Medical Facility Guidelines .....	294
EXHIBIT V - Media Facilities Guidelines .....	296
EXHIBIT W - Electronic Line Calling Facilities Guidelines .....	297
EXHIBIT X - ELC Review Official Protocol.....	298
EXHIBIT Y – ATP World Tour 500 Field Expectation .....	303
EXHIBIT Z - Anti-Doping Testing Facilities Guidelines .....	305
EXHIBIT AA - Retractable Roof Policy .....	307
EXHIBIT AB - ATP Challenger Tour Court Surface ID .....	308

<b>INDEX.....</b>	<b>309</b>
-------------------	------------

## I. ATP CIRCUIT REGULATIONS

### 1.01 Categories of Tournaments

In official men's professional tennis, there are five (5) categories of events. ATP World Tour tournaments and the ATP Challenger Tour tournaments are governed by the ATP. Unless otherwise specified, all regulations are applicable to both ATP World Tour and ATP Challenger Tour tournaments.

#### ATP World Tour tournaments

- Barclays ATP World Tour Finals (singles & doubles)
- World Team Championship
- ATP World Tour Masters 1000
- ATP World Tour 500
- ATP World Tour 250

#### Grand Slams

#### Davis Cup

#### ATP Challenger Tour tournaments

#### Futures tournaments

### 1.02 Tournament Week

**A. Main Draw.** Each ATP World Tour and ATP Challenger Tour tournament is assigned a specific tournament week on the calendar for scheduling of the main draws in singles and doubles commencing on a Monday and concluding on a Sunday, except as approved by the ATP. ATP Challenger Tour tournaments scheduled the second week of a Grand Slam will be permitted to begin on Tuesday with prior ATP approval.

#### B. Matches – Number of Sets.

- 1) **Singles.** All matches, including finals, shall be the best of three (3) tie-break sets.
- 2) **Doubles.** All matches, including finals, shall be two (2) tie-break sets with a deciding Match Tie-break (10 point) at one (1) set all. Games shall be decided using the No-Ad scoring method.

**C Monday Finals.** No ATP World Tour or ATP Challenger Tour tournament shall extend its tournament week for a Monday final without prior approval from the ATP.

#### D. Qualifying.

A tournament may petition, forty-two (42) days prior to the event, for expansion of draw size as long as there is no change in the number of direct acceptances.

- 1) **Singles.** The singles qualifying competition shall be held on the Saturday and Sunday preceding the first Monday of the main draw, except in events scheduled for more than one week or if special permission is obtained from the ATP for a three (3) day event.
  - a) **General.** All tournaments must have a singles qualifying competition (unless there are sufficient places available in the main draw). The singles qualifying competition shall be a single elimination tournament.
    - i) All ATP World Tour 250 events shall have a 32 draw qualifying.
    - ii) ATP World Tour Masters 1000 and ATP World Tour 500 qualifying will be

# I. ATP CIRCUIT REGULATIONS

one half (1/2) the size of the main draw; i.e. a 56 main draw would have a 28 qualifying draw for the 7 qualifying positions.

- b) **Location.** If the qualifying competition is not held at the same site as the main draw, the alternate site must have similar facilities, courts, staff, service and equipment. The qualifying competition may not be held at a site outside the metropolitan area of the main draw without prior written approval of the ATP.
  - c) **Surface.** The qualifying competition shall be played on the same surface as the main draw. In situations beyond the control of the tournament, the supervisor may approve the use of courts with a different surface.
- 2) **Doubles.** ATP Challenger Tour tournaments are encouraged to have a qualifying competition, however it is their option.

## 1.03 Match Schedule Plan

Each tournament shall provide the ATP, at least one hundred and eighty (180) days prior to the start of the tournament, a typed schedule that includes proposed daily starting times and number of courts to be used.

ATP Challenger Tour tournaments should submit their match schedule plan at least ninety (90) days prior to the start of the tournament.

## 1.04 Finals Options

### A. General

- 1) When the singles and doubles finals are to be played on the same day, the doubles final shall be scheduled prior to the singles final, unless otherwise approved by the ATP or due to player conflict.
- 2) When possible, there should be one Awards Ceremony that follows the completion of the singles final. It is mandatory that both singles and doubles finalist players participate in the awards ceremony, whether ceremonies are separate or combined.

### B. Singles

- 1) If any ATP World Tour tournament singles final is not played, the tournament may elect to replace it as follows:
  - a) Schedule a singles exhibition; or
  - b) Re-schedule the doubles final in its place; or
  - c) In the case where the doubles final has been completed or is in progress when it is discovered that there will not be a singles final, the tournament may elect to have the doubles finalists play a one (1) hour exhibition.
- 2) The awards ceremony shall take place immediately following the singles or doubles exhibition or following the doubles final if it has been re-scheduled.

### C. Doubles.

The doubles final should be scheduled approximately two (2) hours prior to the published start time of the singles final, unless otherwise approved by the ATP.

- 1) Exceptions shall be when one (1) or both of the singles finalists are also involved in the doubles final.

# I. ATP CIRCUIT REGULATIONS

- 2) Tournaments may petition the ATP Executive Vice President - Rules & Competition for an exemption to this provision; however, it is the responsibility of the tournament to show that there are valid reasons for justifying the exemption.

## 1.05 Change of Tournament Site

There shall be no change of tournament site without approval from the ATP upon written petition by the tournament. Any and all actual costs incurred by the ATP during the site approval process shall be the responsibility of the tournament.

## 1.06 Commitment to Rules

All ATP World Tour and ATP Challenger Tour tournaments are subject to the jurisdiction of the ATP and shall comply with, be bound by and conduct the tournament in accordance with the ATP rules and regulations.

## 1.07 Commitment, Membership Obligations and Bonus Pool

### A. Player Entry and Commitment To Rules

Any player who is included in the South African Airways ATP Rankings (singles) or the ATP Doubles Rankings and/or commits to enter or participates in any ATP World Tour or ATP Challenger Tour tournament consents and agrees with the following:

- 1) To comply with and be bound by all of the provisions of the 2012 ATP Official Rulebook and the ATP By-Laws (the "ATP Rules"), including, but not limited to, all amendments to the ATP Rules.
- 2) The International Tennis Federation ("ITF") may conduct anti-doping testing at ATP sanctioned events under the Tennis Anti-Doping Program (the "Anti-Doping Program"), the full text of which can be found at [www.itftennis.com/antidoping](http://www.itftennis.com/antidoping). ATP Tour, Inc. ("ATP") will honor and enforce any penalties or sanctions against players resulting from the Anti-Doping Program. The Anti-Doping Program shall apply to and be binding upon all players and shall govern all ATP-sanctioned events including ATP Challenger Tour events. Players shall submit to the jurisdiction and authority of the ITF to manage, administer and enforce the Anti-Doping Program and to the jurisdiction and authority of the Anti-Doping Tribunal and the Court of Arbitration for Sport to determine any charges brought under the Anti-Doping Program. Players also consent to the release to ATP of their Anti-Doping results obtained by the ITF at ATP events, including missed tests and/or filing failures.
- 3) To comply with and be bound by all of the provisions of the 2012 Uniform Tennis Anti-Corruption Program Rules.
- 4) To review and agree to the terms and conditions contained in the Notice of Privacy Practices set forth in Exhibit S.
- 5) Each calendar year all players shall, as a condition of entering or participating in any event organized or sanctioned by ATP, deliver to ATP a signed Consent and Agreement in the form set out in Exhibit R.

### B. Official Means of Communication

The PlayerZone and Player's Weekly are the ATP's official means of communicating

## I. ATP CIRCUIT REGULATIONS

with its player members. All players must stay informed of all information published by the ATP through these official means of communication. Notification of any modifications, deletions or additions to the rules set forth in this Rulebook shall be through such means of communication and shall become effective upon their publication.

### C. Commitment Player

A 2012 ATP commitment player is any player positioned in the Top 30 in the South African Airways ATP 2011 Rankings (singles) as of November 14, 2011.

### D. Commitment

The commitment for the commitment players is, the singles event of all ATP World Tour Masters 1000 tournaments for which he is accepted, the Barclays ATP World Tour Finals (if qualified as a direct acceptance or designated as the alternate) and four (4) ATP World Tour 500 tournaments, one (1) of which must be held following the US Open. For commitment and ranking purposes, the Monte Carlo Masters 1000 will be included in the minimum requirements for the 500 category. 2012 Davis Cup points may be counted as one (1) of the best of six (6) in the ATP World Tour rankings, however, it shall not count towards the commitment requirement of a commitment player.

### E. Commitment Player Entry Exception – Top 30

Commitment players are automatically accepted into the main draw of all ATP World Tour 500 events in which they have entered in a proper manner.

### F. Good Standing

Players are in good standing with the ATP if:

- 1) They pay all outstanding debts and obligations to the ATP;
- 2) They participate in the Barclays ATP World Tour Finals, if qualified as a direct acceptance or designated as the alternate, unless otherwise approved by the ATP;
- 3) They complete all Stars Program responsibilities, if applicable; and
- 4) They are otherwise confirmed to be in good standing by the President.

Penalties for not being in good standing with the ATP result in a player:

- 1) Not being eligible to participate in the bonus program;
- 2) Not being eligible to participate as a main draw entry in the following ATP Year;
- 3) Not being eligible to earn a year of credit toward the ATP retirement program.

### G. ATP World Tour Masters 1000 & Barclays ATP World Tour Finals (“WTF”) Bonus Pool

Players in good standing shall be eligible for the bonus pool based upon their South African Airways ATP Rankings (singles) as of the Monday following the Barclays ATP World Tour Finals in the current year. Rules for bonus pool eligibility are as follows:

## I. ATP CIRCUIT REGULATIONS

29 Nov 2012	Playing 7 of 8* plus	Playing 8 of 8** plus
<u>Ranking</u>	<u>WTF if qualified</u>	<u>WTF if qualified</u>
1	\$1,600,000	\$2,000,000
2	\$800,000	\$1,000,000
3	\$500,000	\$625,000
4	\$400,000	\$500,000
5	\$320,000	\$400,000
6	\$260,000	\$325,000
7	\$220,000	\$275,000
8	\$180,000	\$225,000
9	\$160,000	\$200,000
10	\$140,000	\$175,000
11	\$120,000	\$150,000
12	\$100,000	\$125,000

### 1) Bonus pool distribution is awarded as follows:

\*6 of 8 for players with a one (1) tournament commitment reduction; 5 of 8 for players with a two (2) tournament commitment reduction, plus the Barclays ATP World Tour Finals, if qualified.

\*\*7 of 8 for players with a one (1) tournament commitment reduction; 6 of 8 for players with a two (2) tournament commitment reduction; 5 of 8 for players meeting all three (3) criteria for commitment reduction; plus the Barclays ATP World Tour Finals, if qualified.

### 2) Conditions of eligibility.

- a) **Good Standing.** Player must be in good standing as defined in the ATP Circuit Regulations section of the 2012 ATP Official Rulebook.
- b) **Barclays ATP World Tour Finals.** All players must play, if qualified, in the Barclays ATP World Tour Finals. Alternates must appear and fulfill the requirements of the alternate, as determined by the ATP. A player who is otherwise qualified but does not play in the Barclays ATP World Tour Finals may receive 80% of bonus by appearing at the finals event to do promotional activities, as determined by the ATP.
- c) **Suspended player.** A player who is suspended from an event shall have the suspension count as a missed event for the bonus year in which the event is held.
- d) **Not direct acceptance.** Any player who is not a direct acceptance to a mandatory ATP World Tour Masters 1000 event shall not have that event count as a missed event.
- e) **Promotional work.**
  - i) On-site promotional activities for withdrawn players are applicable for relief of fines and/or suspensions but shall not provide relief for the ranking penalty and shall count as a missed event.
  - ii) On-site promotional activities are not applicable to players missing the event due to being suspended.

# I. ATP CIRCUIT REGULATIONS

The bonus pool distribution payment to players will be made by the end of January 2013.

## 1.08 Reduction of ATP World Tour Masters 1000 Commitment

A. A player's number of ATP World Tour Masters 1000 commitment tournaments shall be reduced by one (1) tournament for reaching each of the following milestones:

- 1) 600 matches\* (as of 1 January of the commitment year);
- 2) 12 years of service;
- 3) 31 years of age (as of 1 January of the commitment year).

If all three (3) conditions are met then the player has a complete exemption from the ATP World Tour Masters 1000 player commitment.

The first Year of Service shall be the first calendar year in which a player has competed in at least twelve (12) tournaments offering ranking points.

\* From 2010 only main draw singles matches played in the following events will be used in the player's match count for purposes of this rule.

ATP World Tour  
Barclays ATP World Tour Final  
Grand Slams  
Davis Cup  
Olympics

Challenger and Futures matches played prior to 2010 will remain on the player's record as relates to this commitment reduction rule.

B. A player who is eligible for a reduction of his ATP World Tour Masters 1000 commitment tournaments must be in good standing with the ATP in order to receive a reduction of required ATP World Tour Masters 1000 commitment tournaments.

## 1.09 Unsatisfied Player Commitment Penalties

### A. Failure To Participate in the Barclays ATP World Tour Finals

- 1) If a player, qualified for the Barclays ATP World Tour Finals as a direct acceptance or designated as the alternate, fails or refuses to participate in this event, except for bona fide injury or other reason which constitutes good cause, the player shall not be in good standing.
- 2) All direct acceptances and the alternate must appear at the site of the event(s) as determined by the ATP and participate in the pre-tournament media conference. Failure to appear shall result in a penalty of five percent (5%) of total ATP prize money earned during the ATP World Tour circuit year.

### B. Review of Penalties for Breach of Commitment

Any player found to have committed a player commitment offense may petition the Appeals Tribunal for discretionary review. This written petition shall detail the basis for the appeal. The tribunal shall review the petition within twenty-one (21) days and, if necessary, designate a date, time and place for a hearing. At the hearing, the player shall present to the tribunal his respective positions on the facts. The tribunal may affirm, reverse or modify the penalty initially imposed by the ATP.

# I. ATP CIRCUIT REGULATIONS

## 1.10 Mandatory Player Meeting

Mandatory player meetings may be scheduled throughout the year as determined and announced in advance by the ATP. These meetings are limited to and mandatory for all main draw singles and doubles players. Player members not entered will be sent the minutes. The penalty for non-attendance is the following:

Year-end ATP Ranking	Amount (USD)
1-10	\$10,000
11-25	\$5,000
26-50	\$2,000
51-100	\$1,000
101 +	\$500

## 1.11 Player Eligibility/Player University/Physical Exam

A. Pursuant to the ATP Bylaws, a player shall be entitled to become an active ATP player member as follows:

- 1) Division one player membership in the ATP shall be open to any individual who, on the date of his application for membership, shall be positioned among the top 200 players in the South African Airways ATP Rankings (singles) or among the top 100 players in the ATP Doubles Rankings and pays ATP dues.
- 2) Division two player membership in the ATP shall be open to any individual who does not qualify for division one membership and who, on and as of the date of his application for membership, shall be positioned among the top 500 players in the South African Airways ATP Rankings (singles) or among the top 250 players in the ATP Doubles Rankings and pays ATP dues.

B. All division one ATP player members must attend an ATP player university within one (1) year after becoming a member.

C. All new division one ATP player members must complete an authorized physical examination within one (1) year after becoming a member.

D. Any ATP player who is eligible for division one membership and does not fulfill the obligations in subsection B and C above shall not be entitled to the privilege of membership.

## 1.12 Waiver of Claims

All players entering ATP World Tour and ATP Challenger Tour tournaments agree, as a condition of their entry, that for themselves, their executors, administrators, heirs and personal representatives, all claims of any kind, nature and description are waived, including past, present or future claims and injuries, if any, sustained in traveling to or from, or participating in, any ATP World Tour or ATP Challenger Tour tournament, as against the ATP, the tournaments concerned and the organizers and sponsors of the tournaments and circuits thereon.

# I. ATP CIRCUIT REGULATIONS

## 1.13 Waiver/Player Publicity and Promotion

All players agree to the following:

- A.** I grant and assign to the ATP and the ATP World Tour tournaments and ATP Challenger Tour tournaments in which I am or have been entered the right in perpetuity to record in tangible form and use my name, performance, likeness, voice, and biography, in any and all media (including the right to produce, display and otherwise use motion pictures, still pictures and live, taped or filmed television and other reproductions of me), solely for purposes of advertising and promoting the ATP World Tour, the ATP World Tour tournaments, ATP Challenger Tour tournaments and other events held as part of the ATP. Any such use of my name, performance, likeness, voice or biography shall be without separate compensation to me or to my heirs, devisees, executors, administrators, legal representatives or assignees. Nothing in this section shall permit the ATP, or the ATP World Tour tournaments and ATP Challenger Tour tournaments to use my name, performance, likeness, voice or biography on any product, service or clothing, or in any manner that constitutes an endorsement of any product, service or company.
- B.** I agree to cooperate with the news media and to participate upon request in reasonable promotional activities of the ATP and the ATP World Tour tournaments and events in which I am entered, subject to my reasonable availability to participate therein. My participation in any such promotional activities or other events shall not be represented to third parties as an endorsement by me of any product or company.
- C.** Any use of my name, likeness, signature, photograph, depiction or video (my "Likeness") on official ATP or ATP World Tour branded merchandise (the "ATP Merchandise") shall be subject to my prior written approval. I agree that my response to any request for my approval will not be unreasonably delayed. With my prior written approval as to the items of ATP Merchandise, the use of my Likeness and the compensation for this use, I grant and assign to the ATP the right to use my Likeness on ATP or ATP World Tour Merchandise, provided that use of my Likeness on any such merchandise shall not conflict with or cause me to be in breach of any current endorsement contract to which I am bound. In the event ATP desires to use my Likeness on ATP or ATP World Tour Merchandise, I acknowledge that I will receive a commission amount agreed upon in writing on any proceeds or revenue generated from such use.

## 1.14 Stars Program

### Responsibilities

- A.** All players competing in the main draw of any ATP World Tour tournament will be required, if asked, to participate in ATP sponsored activities.
- B.** Each player is obligated to provide up to two (2) hours each week as arranged by the ATP staff, for a maximum of up to four (4) separate activities.
- C.** Each player, if requested, is obligated to participate in up to two (2) sets of activities/days for promotional purposes as arranged by ATP. Such activities/days may take place outside of an ATP World Tour tournament week and/or location. Players and their agents will be consulted in advance to ensure that any such activities will not

# I. ATP CIRCUIT REGULATIONS

substantially intrude upon the player's schedule. Players and their agents will also be consulted with respect to the scope and substance of the activities to ensure that the player is comfortable with the proposed activities. ATP will cover all expenses incurred by a player while participating in any such activities.

- D.** Any player who fails to provide the required minimum service shall be subject to the penalties outlined in the player Code of Conduct.

## 1.15 Special Events - Exhibitions

### A. Restrictions

- 1)** Special events are those other than Grand Slams, ATP World Tour tournaments, ATP Challenger Tour tournaments, or Futures tournaments. A player may not compete in a special event if it is scheduled as follows:
- a)** Within the tournament weeks of any ATP World Tour Masters 1000 tournament, ATP World Tour 500 tournament and the Barclays ATP World Tour Finals (singles or doubles). A player who has qualified for and chooses not to play in the ATP World Tour Doubles Championship shall not be eligible for an exemption to play in any special event during that week.
  - b)** Within thirty (30) days before or after the tournament weeks of any ATP World Tour Masters 1000 tournament, ATP World Tour 500 tournament, the Barclays ATP World Tour Finals (singles or doubles), if the special event is located within:
    - i)** One hundred (100) miles or one hundred sixty (160) kilometers of the same; or
    - ii)** The same market area of the city where the tournament is located as determined by the president.
  - c)** Within the period of any ATP World Tour 250 tournament (qualifying competition and main draw) if the special event is located within:
    - i)** One hundred (100) miles or one hundred sixty (160) kilometers of the same; or
    - ii)** The same market area of the city where the tournament is located as determined by the president.
- 2)** Within the tournament week of any ATP World Tour or ATP Challenger Tour tournament in which he is entered including the Sunday night after such tournament final, except as otherwise expressly permitted in the following subsection B.

- B.** A player who is entered into an ATP World Tour 250 tournament may participate in a special event on the Monday of such tournament, provided:

- 1)** He has the permission of the tournament director of the ATP World Tour 250 tournament he is entered in that week; and
- 2)** If he competes in a tournament during the preceding week, he agrees to complete the same if rain or other unavoidable circumstances delay the finals until Monday; and
- 3)** Such special event is not located within:
  - a)** One hundred (100) miles or one hundred sixty (160) kilometers of the same; or
  - b)** The same market area of the city where the tournament is located as determined by the president.



# I. ATP CIRCUIT REGULATIONS

c) Such special event does not violate any of the other restrictions of this rule.

C. This rule shall not apply to players outside the top thirty (30) as of November 14, 2011 (Commitment Players).

D. A player has the right to petition the president or his designee for an exemption to these requirements unless otherwise specified above.

**Case:** *May a player, who is not a Commitment Player after losing, retiring or withdrawing from the qualifying, play in a special event held the following week-end?*

**Decision:** *Yes. However, the player must still ask for and receive a release from the supervisor prior to participating in such special event. (Also see provisions listed in section 7.06 One Tournament Per Week and Exception)*

E. Violations of this section are subject to penalties described under the player Major Offense Conduct Contrary to the Integrity of the Game.

## 1.16 Promotional Fees

A. Except as expressly permitted in subsection B below, a player shall not accept money or anything of value that is given from any source, directly or indirectly, to influence or assure his competing in any ATP World Tour tournament, or ATP Challenger Tour tournaments, other than prize money unless authorized by the ATP.

B. ATP World Tour 500, ATP World Tour 250 tournaments and the ATP World Tour Team Championship have the option to offer fees for promotional services. No other ATP World Tour or ATP Challenger Tour tournament owner, operator, sponsor or agent is permitted to offer, give or pay money or anything of value, nor shall the tournament permit any other person or entity to offer, give or pay money or anything of value to a player, directly or indirectly, to influence or assure a player's competing in a tournament, other than prize money, unless authorized to do so by the ATP.

## 1.17 Electronic Insertion

Each ATP World Tour tournament shall comply with the rules established for electronic insertion. (Exhibit E)

## 1.18 Non-Exclusive Media Highlight Rights.

Each ATP World Tour tournament shall each year promptly (within two business days) provide to ATP without charge existing footage of the tournament as ATP may request. Each ATP tournament hereby grants to the ATP the non-exclusive right to broadcast, or permit to be broadcast, by any means, whether presently existing or hereafter created, in perpetuity worldwide, a total each year of (i) fifteen (15) minutes of footage for the ATP Highlight Show or any other programs, produced by or for the ATP, which are primarily intended to promote the ATP tennis circuit and/or ATP; and (ii) three (3) minutes daily of footage for any local, regional, national or international news or sports news programming.

## 1.19 Quality/Broadcast

Each ATP World Tour tournament shall comply with the Broadcast Quality Standards and regulation regarding Same Day Exclusivity, as per Exhibit C.

# I. ATP CIRCUIT REGULATIONS

## 1.20 Seating and Attendance

A. ATP World Tour tournaments shall have the following minimum stadium court seating capacities, except as approved by the ATP.

<u>Tournament Category</u>	<u>Stadium</u>	<u>Show</u>	<u>Show</u>	<u>All Other</u>
	<u>Court</u>	<u>Court 1</u>	<u>Court 2</u>	<u>Courts</u>
ATP World Tour Masters 1000 (Combined)	12,000	4,000	2,000	400
ATP World Tour Masters 1000 (Outdoors)	10,000	3,000	1,000	
ATP World Tour Masters 1000 (Indoors)	10,000	1,000	400	
ATP World Tour Masters 500 (Outdoors)	7,000	1,000		
ATP World Tour Masters 500 (Indoors)	6,000	500		
ATP World Tour Masters 250 (Outdoors)	3,500			
ATP World Tour Masters 250 (Indoors)	2,500			

B. Each ATP World Tour tournament shall meet two attendance requirements:

- 1) Minimum attendance for the week.
- 2) Average minimum attendance per session during the final weekend of play in excess of 75% capacity for the stadium court.

Specific requirements and methods are specified in Exhibit D.

## 1.21 Hotel Accommodations (Rooms)

### A Tournament Obligations.

All ATP World Tour and ATP Challenger Tour tournaments shall provide hotel accommodations, subject to player obligations, as follows:

#### 1) ATP World Tour Tournaments.

- a) Each tournament shall provide one (1) complimentary double room for the use of each singles player including one (1) guest, at a hotel approved by the ATP. The room must be occupied by the registered player who is responsible for charges resulting from any third or more person(s) staying in the room as well as all incidental costs charged to the room.
- b) Tournaments using more than one (1) hotel as the official hotel may not make player hotel assignments based on a player's entry into the event as a singles or doubles player.
- c) Complimentary use of rooms for the tournament week is to be available for players as follows (accommodations begin no later than Monday).
- d) Main draw players who are no longer eligible for tournament-provided hotel rooms shall receive the published tournament room rate if they extend their stay.
- e) Main draw, ATP World Tour Masters 1000 and ATP World Tour 500 and ATP World Tour 250 (28 draw) qualifying players who have withdrawn on-site for medical reasons and who are examined by the on-site tournament doctor,

# I. ATP CIRCUIT REGULATIONS

shall receive tournament provided hotel rooms through the night of the examination.

- f) Players who travel to the event to complete their promotional activity requirement shall receive full hospitality from the day of arrival through the night following the completion of their promotional obligation.
- i) **ATP World Tour Masters 1000 Tournaments Main Draw.**
  - aa) **Singles:** Rooms for singles players should be available beginning on Friday and continuing for a minimum of seven (7) nights. Where the main draw has been approved for a Sunday start, Hospitality shall begin one (1) day earlier than specified. This is applicable to both the singles and doubles main draw players. Accommodations continue through the night that he plays his last match or until his seven (7) night minimum has been provided, whichever is later.
  - bb) **Doubles:** Rooms for doubles players shall be available beginning Saturday. For doubles players who stay in individual rooms, hospitality shall be for a minimum of two (2) nights or through the night that the player plays his last match, whichever is later. A doubles player who shares a room with another main draw doubles player shall have a minimum of four (4) nights or through the night of that players' last match, whichever is later.
  - cc) **Sunday Start.** Where the main draw has been approved for a Sunday start, Hospitality shall begin one (1) day earlier than specified. This is applicable to both the singles and doubles main draw players. **NOTE:** Singles Hospitality for Indian Wells and Miami begins three days prior to the main draw. Doubles Hospitality begins two days prior to the start of doubles play.
- ii) **ATP World Tour 500 Tournaments Main Draw.**
  - aa) **Singles:** Rooms for singles players should be available beginning on Friday and continuing for a minimum of six (6) nights. Where the main draw has been approved for a Sunday start, Hospitality shall begin one (1) day earlier than specified. This is applicable to both the singles and doubles main draw players. Accommodations continue through the night that he plays his last match or until his six (6) night minimum has been provided, whichever is later.
  - bb) **Doubles:** Rooms for doubles players shall be available beginning Saturday. For doubles players who stay in individual rooms, hospitality shall be for a minimum of two (2) nights or through the night that the player plays his last match, whichever is later. A doubles player who shares a room with another main draw doubles player shall have a minimum of four (4) nights or through the night of that players' last match, whichever is later.
  - cc) **Sunday Start.** Where the main draw has been approved for a Sunday start, Hospitality shall begin one (1) day earlier than specified. This is applicable to both the singles and doubles main draw players.
- iii) **ATP World Tour 250 Tournaments Main Draw\*.**
  - aa) **Singles:** Rooms for singles players should be available beginning on Saturday and be available to each singles player for a minimum of five (5) nights, regardless of when the player is finally accepted into the main draw (singles qualifiers). Where the main draw has been approved for a Sunday start, Hospitality shall begin one (1) day earlier than specified. This is applicable to both the singles and doubles

# I. ATP CIRCUIT REGULATIONS

main draw players. Accommodations continue through the night that he plays his last match or until his five (5) night minimum has been provided, whichever is later.

\*ATP World Tour 250 events with a 28 main draw shall provide hospitality for the qualifying event players.

- bb) **Doubles:** Rooms for doubles players shall be available beginning Saturday.  
For doubles players who stay in individual rooms, hospitality shall be for a minimum of two (2) nights or through the night that the player plays his last match, whichever is later. A doubles player who shares a room with another main draw doubles player shall have a minimum of four (4) nights or through the night of that players' last match, whichever is later.
  - cc) **Sunday Start.** Where the main draw has been approved for a Sunday start, Hospitality shall begin one (1) day earlier than specified. This is applicable to both the singles and doubles main draw players. \*ATP World Tour 250 events with a 28 main draw shall provide hospitality for the qualifying event players.
  - iv) **ATP World Tour Masters 1000, ATP World Tour 500 and ATP Tour World Tour 250 Qualifying\*:**
    - aa) Hotel accommodations for players in the singles qualifying should be available to begin on the night before the start of qualifying competition and be available to each player through the night of the player's last qualifying match.
    - bb) Successful qualifiers shall be afforded the same hotel accommodations as those offered to main draw singles players, however, the nights used under qualifying hotel accommodations shall count toward the tournament's minimum number of nights required. \*ATP World Tour 250 events with a 28 main draw shall provide hospitality for the qualifying event players.
- 2) **ATP Challenger Tour Tournaments.**
- a) Complimentary hotel accommodations are optional at ATP Challenger Tour tournaments offering a minimum of \$50,000 in prize money. For those events offering prize money of \$35,000, complimentary hotel accommodations are a requirement. Tournaments offering complimentary hotel accommodations must provide rooms for all singles and doubles main draw players. Challenger tournaments that provide complimentary hotel accommodations will qualify for credit toward an increase to the next category of ATP Ranking points. Accommodations are defined as one (1) complimentary double room for the use of each player, including one (1) guest, at a hotel approved by the ATP. The room must be occupied by the registered player who is responsible for charges resulting from any third or more person(s) staying in the room as well as all incidental costs charged to the room. Complimentary use of rooms for the tournament week are to be available beginning on Saturday\* and be available to each singles player for a minimum of five (5) nights, regardless of when the player is finally accepted into the main draw (singles qualifiers). Accommodations continue through the night that he plays his last match or until his five (5) night minimum has been provided, whichever is later. Accommodations begin no later than Monday.
  - b) Rooms for doubles players should be available beginning on Saturday\*

# I. ATP CIRCUIT REGULATIONS

through the night of the player's last match. The tournament is not required to provide a five (5) night minimum for doubles players.

- c) ATP Challenger Tour tournaments offering prize money of \$35,000 are required to provide complimentary hotel accommodations as detailed in sub-sections a. and b. above.
- d) Main draw players who are no longer eligible for accommodations shall receive the published tournament room rate if they extend their stay.
- e) Main draw players who have withdrawn on-site for medical reasons and who are examined by the on-site tournament doctor shall receive hospitality through the night of the examination.
- f) Tournaments using more than one (1) hotel as the official hotel may not make player hotel assignments based on a player's entry into the event as a singles or doubles player.

**\*NOTE:** In Challenger events where the main draw begins on Tuesday, hospitality for both the singles and the doubles will begin on Sunday.

## B. Player Obligations

- 1) Each main draw player must make a hotel reservation no later than two (2) weeks prior to the first Monday of the tournament with either the hotel or the tournament, as specified on the ATP World Tour tournament information sheet. Reservation changes can be made up to forty-eight (48) hours prior to the start of the reservation except that a player still competing in either singles or doubles in the prior week's tournament must also confirm his reservations when travel plans are finalized.
- 2) **Penalties for breaching obligation:**
  - a) Failure to make a reservation two (2) weeks prior to a tournament shall result in a player losing his hotel accommodation privileges for that tournament.
  - b) Player forfeits hotel accommodations for nights reserved but not used.
  - c) Player forfeits hotel accommodation privileges for four (4) consecutive tournaments when he either:
    - i) Does not pay all incidental costs charged to a room; or
    - ii) Does not personally stay in the room as required; or
    - iii) Does not cancel reservation(s) previously made at tournament hotel(s); or
    - iv) Damages a room or hotel facilities;
    - v) Unprofessional or abusive behavior towards any hotel employee or guest;
    - vi) Severe unprofessional behavior in or on the hotel premises and not specifically covered above.
- 3) **Other Reservations.** Players can request additional room reservations at the player rate if they contact the tournament no later than two (2) weeks prior to the start of the tournament.
- 4) **Qualifier Reservations.** Players participating in the qualifying competition who wish to receive a player rate at a tournament hotel must make a hotel reservation no later than five (5) days prior to the qualifying sign-in deadline with either the hotel or the tournament, as specified on the ATP information sheet. Reservation changes can be made up to forty-eight (48) hours prior to the start of the reservation except that a player still competing in either singles or doubles in the prior week's tournament must confirm reservations when his travel plans are finalized.

# II. BRANDING

## 2.01 Identification - ATP World Tour Tournaments

**A.** Each ATP World Tour tournament shall identify itself clearly to the public as being part of the ATP World Tour and shall cooperate fully with the ATP in furthering public awareness of the ATP World Tour. Participation in the ATP World Tour shall not restrict the right of the tournament to obtain individual sponsorship or to retain its usual title.

**B. Trademark and Logo Identification.** Each ATP World Tour tournament and ATP Challenger Tour tournament shall comply with the terms and conditions for the use of the ATP World Tour and the ATP Challenger Tour trademark and logo outlined in Exhibit B.

**C.** Except as otherwise approved by the ATP, each ATP World Tour tournament shall comply with the ATP World Tour Branding Application Requirements and shall assume all costs associated with such compliance. Branded nets and microphone flags will be provided, without cost, to all tournaments by the ATP. ATP World Tour and ATP Challenger Tour Application Requirements will be provided to each tournament by the ATP.

### 1) ATP World Tour Official Tournament Stamps: Application Rules (Exhibit A.01)

All ATP World Tour tournaments must display the appropriate ATP World Tour Official Tournament Stamp (Masters 1000, 500, or 250) on all compulsory materials containing the tournament logo, as identified in the rules below. The tournament logo is the official identity of the tournament that includes the tournament name. When a text alternative to the tournament logo is used, it will be regarded as the tournament logo and the rules below will continue to apply. When a tournament logo is used repeatedly, or if both tournament logo and tournament title are used, application rules will apply to the largest tournament logo or title. For multiple page external documents, the ATP World Tour Official Tournament Stamp must be applied on the front page in accordance with the rules below.

#### a) Size Relationship

##### i) Men only events (Exhibit A.02)

The ATP World Tour Official Tournament Stamp must be a minimum of 60% of the surface area of the tournament logo or tournament title, whichever is larger. This is subject to the minimum size rules for the ATP World Tour Official Tournament Stamps below.

##### ii) Combined events (Exhibit A.03)

The ATP World Tour Official Tournament Stamp should be presented with the WTA Tour logo to communicate to audiences that the tournament is part of both tours.

- **Size relationship: WTA Tour Logo**

The ATP World Tour Official Tournament Stamp must be the same visual size (cover the same surface area) as the WTA Tour logo.

- **Size Relationship: Tournament Logo**

When the ATP World Tour Official Tournament Stamp is used in conjunction with the WTA Tour logo, the Official Stamp must be at a minimum equal size to the WTA Tour logo or 30% of the surface area

## II. BRANDING

of the tournament logo, whichever is greater. This is subject to the minimum size rules for Official Stamps below.

### iii) Minimum Size

To ensure the ATP World Tour Official Tournament Stamps are reproduced to best effect, the tournaments must adhere to the application rules stated in i) and ii) above or the following minimum sizes, whichever is greater:

In quality print	9mm wide
In newsprint	13mm wide
On screen	45 pixels wide

### Size Requirements

Below are the minimum size requirements for using the ATP World Tour Official Tournament Stamps on printed materials.

A7	9mm wide
A6	11mm wide
A5	14mm wide
A4	18mm wide
A3	26mm wide
A2	36mm wide
A1	51mm wide

In non 'A' format communications the width of the ATP World Tour Official Tournament Stamps should be no smaller than 6% of the longest side of the layout.

### b) Positioning (Exhibit A.04)

#### i) Proximity to the tournament logo

The ATP World Tour Official Tournament Stamp must be placed closest to the tournament logo. No sponsor (with exception of the presenting sponsor), federation, series logo or any other logo may be closer to the tournament logo than the ATP World Tour Official Tournament Stamp. Tournament logo cannot include any series name, federation name or any other name or brand mark.

#### ii) Proximity to Sponsor logos

The ATP World Tour Official Tournament Stamps are used as an endorsement of the quality and authenticity of a tournament and its inclusion within the ATP World Tour. The ATP World Tour Official Tournament Stamps should never be placed alongside sponsor logos or added to sponsor logo strips.

### c) Exclusion Area (Exhibit A.05)

#### i) Exclusion Area 1: For graphics, images, text, WTA Tour and tournament logos (including 'presented by' sponsor)

A minimum exclusion area equal to the height of the ATP type has been established around the ATP World Tour Official Tournament Stamps. No graphics, images, text, WTA Tour or tournament logos must appear in this area. This exclusion area must be maintained.

#### ii) Exclusion Area 2: For sponsor, federation and series logos

A minimum exclusion area equal to the width of two ATP World Tour Official Tournament Stamps has been established around the ATP World Tour Official Tournament Stamps. No sponsor, federation or series logos must appear in this area. This exclusion area must be maintained.

## II. BRANDING

### d) Acceptable and unacceptable applications (Exhibit A.06.1 to A.06.06)

### 2) ATP World Tour Official Tournament Stamps : Compulsory Applications

An ATP World Tour tournament must identify itself as an ATP World Tour event by applying the appropriate ATP World Tour Official Tournament Stamp, in accordance with the rules listed in section 1) above, in the following compulsory applications:

#### a) Promotion

##### i) Advertising

The ATP World Tour Official Tournament Stamp must be applied to all tournament advertising communications.

##### ii) Communication / Administration / Presentations

The ATP World Tour Official Tournament Stamp must be applied to all external tournament communications. To include but not limited to: stationery, memos, powerpoint's, documents and press releases. For multiple page documents, the ATP World Tour Official Tournament Stamp need only be applied on the front page that contains tournament logo or tournament name.

##### iii) Website / Other Digital Products - Exhibit A.07)

The ATP World Tour Official Tournament Stamp must be displayed on all pages of the tournament website and other digital products intended for large format display, e.g. desktop, laptop, tablet computers, and be located within the upper 20% of the pages within the masthead area as the closest logo to the tournament logo. The ATP World Tour Official Tournament Stamp should be no smaller than 45 pixels wide for websites and other digital products intended for large format display and follow the C. 1) a) Size Relationship rule for mobile websites and other digital products intended for small format display, e.g. mobile handsets.

##### iv) Promotional Materials

The ATP World Tour Official Tournament Stamp need only be applied to the front page of all promotional communications. To include but not limited to: tournament programs, daily programs, leaflets, draw sheets, announcements and notices. For multiple page documents, the ATP World Tour Official Tournament Stamp need only be applied on the front page that contains tournament logo or tournament name.

##### v) ATP Advertisement.

Three (3) full pages of ATP World Tour advertisements must be included in the tournament program with two (2) of the three (3) pages within the first third (1/3) of the tournament program to be used to promote and advertise the ATP World Tour. (The three (3) pages are separate from any other page requirements specified in an ATP Sponsorship Agreement between a tournament and the ATP).

The ATP will supply the advertisement and it shall be printed without expense to the ATP. One (1) of the three (3) pages must be the doubles program ad as furnished by the ATP.

### Violations.

Violation of this section shall subject a tournament to a fine up to \$50,000 for each violation. In cases that are flagrant and particularly injurious to

## II. BRANDING

the success of the ATP World Tour, the Executive Vice-President Rules & Competition may refer the matter to the ATP Board for further action which could include additional fines and/or change in membership status.

**Note:** When possible, tournaments will be given notice of and the opportunity to correct any issues that would put them in a violation of the above rules.

### b) Compulsory Application: On-site

#### i) Entrance

The ATP World Tour Official Tournament Stamp must be displayed at all entrances to the tournament that include the tournament logo or the tournament title, unless otherwise approved by the ATP. To include but not limited to: car parks, main stadium, press, player and VIP entrances.

#### ii) Scoreboards / Drawboards (Exhibit A.08)

If a scoreboard / drawboard includes the tournament logo or tournament title then the ATP World Tour Official Tournament Stamp must be displayed.

#### iii) Singles / Doubles Leader Boards (Exhibit A.09)

The current standings of the South African Airways 2012 ATP Rankings for singles and 2012 ATP Doubles Team Rankings must be placed prominently in the tournament stadium grounds. Artwork will be provided by the ATP. Preferred position is in the main welcome area.

#### iv) Vehicles

The ATP World Tour Official Tournament Stamp must be applied to any vehicle that displays the tournament logo or the tournament title.

### c) Compulsory Application: On-court

#### i) The Court

No commercial branding (sponsor, series or federation), court manufacturer branding or any other mark may be placed on the surface of the court, with the exception of "Host Locality" (See 3b) unless otherwise approved by the ATP.

#### ii) Net (Exhibit A.10)

All ATP World Tour tournaments must use the ATP World Tour branded net on all courts, as determined and provided by the ATP. Branded nets will be provided, without cost, to all tournaments by the ATP. No commercial or other branding is allowed on the net or net posts other than that specified or otherwise approved solely by the ATP.

**Violation of this requirement (c. ii.) shall subject a tournament to a fine up to \$50,000 per day for each day the tournament is in non-compliance. In cases that are flagrant and particularly injurious to the success of the ATP World Tour, the Executive Vice-President Rules & Competition may refer the matter to the ATP Board for further action which could include additional fines and/or change in membership status.**

**Note:** When possible, tournaments will be given notice of and the opportunity to correct any issues that would put them in a violation of the above rules.

- **Net Example 1: Net without sponsor branding**

At tournaments where the ATP World Tour premier partner branding is not used, ATP net signage shall be displayed on the left and right sides of the net on all match courts.

## II. BRANDING

- **Net Example 2: Net with sponsor branding**

At tournaments where the ATP World Tour premier partner branding is used, net signage will be displayed on the left and right sides of the net on all match courts.

- **Positioning of net signage (ATP or ATP World Tour premier partner)**

- o For singles matches using a doubles net, net signage must be centered between the singles stick and the net post.

- o For singles nets, net signage must be centered between the singles sideline and the net post.

### iii) ATP Supervisors / ATP Designated Chair Umpires

The officiating uniform provided by the ATP must be worn. No other commercial branding may be applied to the uniform without prior approval from the ATP.

### iv) ATP Physiotherapists

The uniform provided by the ATP must be worn.

### v) Chair Umpire Microphones

An ATP World Tour microphone cover must be used on the chair umpire's microphone. The appropriate ATP World Tour Official Tournament Stamp must appear on all four sides. Microphone flags will be provided by the ATP.

### Violations.

Violation of this section (with the exception of c. ii) shall subject a tournament to a fine up to \$50,000 for each violation. In cases that are flagrant and particularly injurious to the success of the ATP World Tour, the Executive Vice-President Rules & Competition may refer the matter to the ATP Board for further action which could include additional fines and/or change in membership status.

**Note:** When possible, tournaments will be given notice of and the opportunity to correct any issues that would put them in a violation of the above rules.

### d) Compulsory Application: Media & Broadcast

#### i) Media Backdrop (Exhibit A.11)

The ATP World Tour Official Tournament Stamp must be displayed on the official tournament media backdrop in such a way that it is clearly visible during the actual interview, in accordance with size, positioning and exclusion area rules.

#### ii) Interview Room Microphone

An ATP World Tour microphone cover must be used on all player interview microphones. The appropriate ATP World Tour Official Tournament Stamp must appear on all four sides. Microphone flags will be provided by the ATP.

#### iii) Broadcast

The ATP World Tour Official Tournament Stamp must be displayed on all tournament broadcasts on any screen where the tournament logo is featured, unless otherwise approved by the ATP.

### Violations.

Violation of this section shall subject a tournament to a fine up to \$50,000

## II. BRANDING

for each violation. In cases that are flagrant and particularly injurious to the success of the ATP World Tour, the Executive Vice-President Rules & Competition may refer the matter to the ATP Board for further action which could include additional fines and/or change in membership status.

**Note:** When possible, tournaments will be given notice of and the opportunity to correct any issues that would put them in a violation of the above rules.

### 3) ATP World Tour Branding: Optional Applications

An ATP World Tour tournament may wish to further identify itself as an ATP World Tour event by applying the appropriate ATP World Tour Official Tournament Stamp in the following optional applications:

#### a) Court Surface Color (Exhibit A.12)

The preferred hard court surface color for all ATP World Tour events is a match to PMS 281, to be used inside the court lines and a match to PMS Cyan, used outside the court lines.

#### b) Court Host Locality (Exhibit A.13)

Tournaments may feature only the name of the country, city or region (example: Germany, Munich or Bavaria) on the court surface in the approved ATP World Tour font - 77 Helvetica Neue Bold Condensed as illustrated. The on-court logo must be consistent with the texture and feel of the court surface so as not to affect play or be a safety hazard.

##### i) Host Locality Option 1

Host country/city/region must be written in upper case in white on both sides of the court at the service line.

Host country/city/region can be displayed on one or two lines, facing the main camera.

Text height must be 40cms (16").

Text should not be placed further than 40cms (16") from the doubles line.

When text is displayed on two lines, they should together be centered on the service line.

Line spacing should be 20cms (8").

Host country/city text should be elongated by 27% for improved television visibility.

If used on a clay surface, the text must not protrude above the surface of the court.

##### ii) Host Locality Option 2 (Not for use on clay)

Host country/city/region must be written in upper case in white on both sides of the court, centered between the singles sidelines.

Host country/city/region must be displayed on one line, facing the main camera.

Text height must be 50cms (20").

The closest distance permitted from the baseline is 300cms (9' 10").

#### c) Court Backdrops – Color (Exhibit A.14)

The preferred backdrop color for all ATP World Tour tournaments is the closest match to PMS 281.

##### i) Lettering.

PMS Cool Grey 5 is the preferred color used for lettering. If the tournament selects color combinations other than those outlined in the previous

## II. BRANDING

sentence, then such color combinations may not include shades of white, yellow or other light colors and must be approved in advance by the ATP.

##### ii) Rotating Banners.

Background and lettering on Rotating Banners should be consistent with the color of the back walls. Rotating Banners can change between games.

#### d) Court Backdrops – ATP World Tour Official Tournament Stamps (Exhibit A.14)

##### i) ATP World Tour Men Only Events.

The ATP World Tour Official Tournament Stamp may be used in the left and right corners of the backdrop, facing the main camera. If a tournament decides to do so, the ATP World Tour Official Tournament Stamp must be placed in a non-obstructed position, away from ball persons, scoreboards or corner camera positions. The ATP World Tour Official Tournament Stamp must be 40% of the height of the board, and placed in the top 60% of the board.

##### ii) Combined Events.

If the WTA logo is placed on the back wall of the court then the ATP World Tour Official Tournament Stamp must also be placed on the back wall in equal size and with equal television visibility.

#### e) On-court Ball Persons / Linesmen

If a tournament wishes to use the appropriate ATP World Tour Official Tournament Stamp on the uniforms of ball persons or linesmen, the application of the ATP World Tour Official Tournament Stamp must be approved in advance by the ATP.

#### f) Merchandise

The ATP World Tour Official Tournament Stamp may be used on tournament merchandise only in conjunction with the official Tournament logo, provided that such a use complies with the terms and conditions set forth in the ATP Rulebook. Specific application requirements will be provided to tournaments separately. Any and all applications must be approved by the ATP's retail merchandise consultant, at a minimum three (3) months in advance. No approval is required if merchandise is obtained from an approved ATP licensee.

## 2.02 Identification - ATP Challenger Tour Tournaments

### A. Challenger Tournaments. (Exhibit A.15)

Each Challenger tournament shall identify itself as an ATP Challenger Tour tournament and shall use the ATP Challenger Tour Brand Mark as presented in Exhibit A.15 (the "Brand Mark").

#### 1) ATP Challenger Tour Brand Mark: Compulsory Applications

An ATP Challenger Tour tournament must identify itself as an ATP Challenger Tour tournament by applying the Brand Mark in the following compulsory applications:

##### a) Website / Other Digital Products (Exhibit A.16)

The Brand Mark must be displayed on all pages of the tournament website and other digital products intended for large format display, e.g. desktop, laptop, tablet computers, and be located within the upper 20% of the pages within the masthead area as the closest logo to the tournament logo. It must

## II. BRANDING

not be smaller than 112 pixels wide for websites and other digital products intended for large format display and follow the 2.01 C. 1) a) Size Relationship rule for mobile websites and other digital products intended for small format display, e.g. mobile handsets.

**b) Program**

The Brand Mark must be displayed on the cover in the top 40%. It must not be smaller than 28mm (1.1") wide.

**c) Drawsheets**

The Brand Mark must be displayed in the top 40%. It must not be smaller than 28mm (1.1") wide.

**d) Entrance**

The Brand Mark must be displayed prominently at the main entrance to the tournament.

**e) Court Backdrops (Exhibit A.17)**

The Brand Mark must be displayed in the left and right corners of the court backdrops (back fences or back walls), it must not be used smaller than 60cm (23.625") wide. Brand Marks must be placed in a non-obstructed position.

**Violations.**

Violation of this section shall subject a tournament to a fine up to \$10,000 for each violation. In cases that are flagrant and particularly injurious to the success of the ATP World Tour, the Executive Vice-President Rules & Competition may refer the matter to the ATP Challenger Committee for further action which could include additional fines and/or loss of sanction.

**2) ATP Challenger Tour Brand Mark: Optional Applications**

An ATP Challenger Tour tournament may wish to identify itself as an ATP Challenger Tour event by applying the Brand Mark in the following optional applications:

**a) Advertising**

The Brand Mark may be applied to any advertising where the tournament logo is featured.

**b) On-Site**

The Brand Mark may be applied to any on-site drawboards, scoreboards, vehicles, banners, flags or signage featuring the tournament logo.

**c) Media Center**

The Brand Mark may be displayed on tournament media backdrops.

**d) Broadcast**

The Brand Mark may be displayed on any tournament broadcasts where the tournament logo is featured.

**e) Merchandise**

The Brand Mark may be used on tournament t-shirts and sweatshirts (not collared shirts). The Brand Mark must not exceed 100mm (3.937") wide. Written approval is required from ATP if producing these items yourself. No approval is required if merchandise is obtained from an approved ATP licensee.

**f) Net.**

There shall be no advertising on the net or net posts without the prior approval of the ATP.

**i)** Requests for approval must be sent to the ATP Challenger Tour Administrator, Monte Carlo.

## II. BRANDING

**ii)** Requests for approval must be received no later than three (3) weeks prior to the Monday of the event week.

**iii)** Request must include:

- Name of sponsor
- Business type
- Dimensions of proposed signage
- Color rendition of proposed signage.

**iv)** Requests and approval are on an annual basis.

**B. ATP Challenger Tour Tournaments - The Court**

No commercial branding (sponsor, series or federation) or any other mark may be placed on the surface of the court, except as follows:

**1)** "Host Locality" (See 2.01 C. 3b and Exhibit A.13).

**2)** Court Surface Manufacturer-Branding. ATP Challenger Tour tournaments are allowed to place the court surface manufacturer's name on the surface of the court. The size and placement must be approved three (3) months in advance by the ATP. (See Exhibit AB)

### III. FINANCIAL

#### 3.01 Composition of Commitment

Each tournament's financial commitment is composed of on-site prize money and tournament fee obligations unless otherwise approved by the ATP.

#### 3.02 Currency

All references to money are expressed in United States Dollars (USD) and Euros (EUR), unless otherwise designated. Tournament fees, fines and other amounts payable to the ATP are payable in USD or EUR.

#### 3.03 Default of Prize Money Payments

Any ATP World Tour or ATP Challenger Tour tournament that defaults in payment of prize money or tournament fee or any other payments due to the ATP may have its membership status (sanction status if ATP Challenger Tour tournament) changed subject to the ATP Bylaws.

#### 3.04 Fee Obligation

A. ATP World Tour and ATP Challenger Tour tournaments must pay to the ATP as part of their total financial commitment the following fee based on prize money level and tournament classification, unless otherwise determined by the ATP:

- ATP World Tour Masters 1000
  - 6.5% Tour Fee
  - 5% Marketing Fee
  - 7% Bonus Pool Contribution
  - Sanction protection fee, where applicable
- ATP World Tour 500
  - 6.5% Tour Fee
  - 5% Marketing Fee
  - Other agreed fees, where applicable
    - o sanction protection
    - o remaining bid premium
    - o 500's escrow account
- ATP World Tour 250
  - 6.5% Tour Fee
  - 5% Marketing Fee
- ATP Challenger Tour 15% of the Prize money

B. All fees shall be due and payable as follows:

**1) ATP World Tour Tournaments:**

- a) Six (6) months prior to the first day of the tournament, the Advance Fee is due:
- |                             |                  |
|-----------------------------|------------------|
| ATP World Tour Masters 1000 | \$60,000/€51,000 |
| ATP World Tour 500          | \$50,000/€42,500 |
| ATP World Tour 250          | \$12,500/€10,625 |
- b) The first day of the tournament, the Balance Fee is due and payable.

**2) ATP Challenger Tour Tournaments.** The full fee is due with the tournament application.



### III. FINANCIAL

- 3) **Late Payments.** Fee payments not received by due dates are subject to a late charge of 2% per month.

#### 3.05 Fees/Other Payments

- A. All fees and monies due to the ATP are to be sent by wire or check in USD or EUR.
- B. Any amounts (e.g. player fines, non-member service fees, air-tickets) collected or owed by the tournament to the ATP must be remitted to the ATP.

#### 3.06 Insurance

- A. Each ATP World Tour tournament shall obtain and maintain general liability insurance or the equivalent thereof. Masters 1000 events shall maintain a minimum limit of \$10,000,000 USD and all other events shall maintain limits of not less than \$5,000,000 USD with an insurance carrier maintaining a financial rating of "A" by AM Best and acceptable to the ATP
- 1) The liability insurance shall include bodily injury and property damage liability, personal injury, participant legal liability hired and non-owned auto and contractual liability coverage.
  - 2) The tournament liability insurance shall name the ATP Tour, Inc. (a United States Corporation), its director and officers, employees, agents as additional named insured's with respect to any claim or suits brought against the ATP, its officials, employees, agents, regardless of the court of jurisdiction, arising out of the negligence of the tennis tournament, its directors or representatives.
  - 3) Coverage will include volunteers, on-court officials and ball persons as "named insured's" under the policy.
- B. Each ATP World Tour tournament is responsible for determining whether applicable worker's compensation statutes apply to injuries sustained by volunteers, sub-contractors, on-court officials or ball persons. In the absence of a worker's compensation coverage requirement, it is recommended that the tournament purchase excess medical insurance for the event to provide medical payments coverage to injured volunteers, on-court officials or ball persons involved in the event.
- C. All such insurance shall provide, not less than thirty (30) days, prior written notice to the ATP of cancellation.
- D. Each ATP World Tour tournament shall furnish to the ATP no later than sixty (60) days prior to such tournament a certificate of insurance from such insurance carrier certifying compliance with the above requirements.

#### 3.07 Letter of Credit - New/Conditional Tournaments

Unless otherwise determined by the ATP, each ATP World Tour tournament with conditional membership status must submit to the ATP within the time period required, an approved irrevocable Letter of Credit, in form and substance, satisfactory to the ATP, from an ATP approved bank in the amount of the on-site prize money. Such Letter of Credit must have an expiration date no earlier than one (1) month after the last scheduled day of the ATP event.

### III. FINANCIAL

#### 3.08 Prize Money

##### A. General

##### 1) ATP World Tour

- a) Prize money at all ATP World Tour events shall be paid through the ATP or its designated agent at the conclusion of the tournament, unless otherwise approved by the ATP. Prize money shall be distributed based on breakdowns established by the ATP. ATP must approve any changes in prize money, including from year to year.
- b) The ATP must receive the electronically completed ATP prize money excel spreadsheet no later than the end of the business day on the Monday following the conclusion of the tournament. The spreadsheet must be emailed to [accounting@atpworldtour.com](mailto:accounting@atpworldtour.com).
- c) Tournaments are required to wire net prize money to the designated bank trust account to ensure receipt by the Wednesday following the conclusion of their respective events.

##### 2) ATP Challenger Tour

- a) Prize money at all ATP Challenger Tour events shall be paid through the ATP or its designated agent at the conclusion of the tournament, unless otherwise approved by the ATP.
- b) The ATP must receive 100% of the prize money no later than the Friday prior to the start of the tournament.
- c) The ATP must receive the electronically completed ATP prize money excel spreadsheet no later than the end of the business day on the Monday following the conclusion of the tournament. Spreadsheet must be emailed to [accounting@atpworldtour.com](mailto:accounting@atpworldtour.com).

- 3) Prize money shall be paid only for matches played. If a final cannot be played, then each finalist shall be paid only runner-up prize money. For purposes of this section, a match is played when it is won as a result of a retirement, default, walkover or no show. (See Exhibit O)

**Doubles:** Should a doubles match in an ATP World Tour or ATP Challenger Tour event be uncontested or fail to be completed, the losing team shall only receive points and prize money from the previous round unless one of the following is applicable:

- a) Neither player was in the singles main draw.
  - b) The retiring/withdrawing player is still in the singles competition and at the time of the medical examination is declared unfit to play in the singles of that event or, if no longer involved in the singles competition of that event, is forced to withdraw from the singles or doubles\* of the next tournament in which he is entered.
- \* For ATP Challenger events the withdrawal for doubles must be after the withdrawal deadline.
- c) The withdrawing player had retired/withdrawn from his singles match, which was scheduled the same day.

- i) A team withdrawing from the first round will not receive prize money even if there is not an alternate team.
- 4) A player who receives a "bye" and loses in the second round shall receive second round loser's prize money.

### III. FINANCIAL

- 5) Players affected by the entries or seedings not in accordance with ATP Rules and Regulations shall not be entitled to compensation. Such entry or seeding variances shall be resolved at the sole discretion of the Executive Vice President - Rules & Competition.
- 6) A tournament must send to the ATP any prize money not paid to a player who is defaulted for improper conduct.

#### 3.09 On-Site Prize Money

Each ATP World Tour and ATP Challenger Tour tournament is required to offer and pay as part of its financial commitment not less than the on-site prize money shown in Exhibit J plus hotel accommodations, unless otherwise determined by the ATP. The minimum prize money for the ATP Challenger Tour Tournaments is \$35,000/€30,000.

#### 3.10 Prize Money / Fee Payments

##### A. ATP World Tour Tournaments

Prize money and fee payments by all ATP World Tour level tournaments shall be determined as follows:

- 1) U.S. tournaments: all prize money, fees etc. must be paid in USD.
- 2) All European Region tournaments: all prize money, fees etc. must be paid in EUR.
- 3) All other tournaments: all prize money, fees etc. must be paid in USD. Any change from USD payment must be approved by the ATP Board.

##### B. ATP Challenger Tour Tournaments

Prize money and fee payments by all ATP Challenger Tour tournaments shall be determined as follows:

- 1) **U.S. Challengers:** All prize money and fees must be paid in USD.
- 2) **European Region Challengers:** All prize money and fees must be paid in EUR.
- 3) **All other ATP Challenger Tour events:** Prize money and fees must be paid in USD.

#### 3.11 On-Site Prize Money Adjustment

##### A. Exchange Rate Adjustment Rule

There will be no prize money adjustment for tournaments in the U.S. and tournaments in the ATP's European Group, except for those in non-euro based countries. For all other tournaments, the on-site prize money will be increased or decreased from approved prize money levels when there are significant exchange rate changes between USD or EUR / local currency. The amount of the prize money adjustment shall be determined as follows:

- 1) As of March 31 and September 30 of each year, ATP will compare the current market exchange rate (ratio of local currency to USD or EUR with the 5-year average of the same currency exchange rate) for each non-U.S./non-European Group

### III. FINANCIAL

country in which tournaments are played, and calculate the change between the current rate and average rate as a percentage of the average rate. Prize money amounts in USD for tournaments in countries where more than 10% change occurs will be adjusted by one-half of the percentage change subject to a maximum adjustment of 15%. The March 31 calculation will apply to tournaments that begin on dates from January 1 through June 30 of the following year. The September 30 calculation will apply to tournaments that begin on dates from July 1 through December 31 of the following year.

- 2) When prize money is adjusted under this rule, prize money must be paid in USD or EUR. Ranking points will be based on approved prize money levels prior to any adjustment pursuant to this section. This section will not apply to tournaments in countries where currencies are not actively traded.
- 3) The Exchange Rate Adjustment rule does not apply to ATP Challenger Tour events.

#### 3.12 Payment

A. For non-U.S. and non-euro based events, on-site prize money may be paid in USD or in a non-U.S. currency if approved by the ATP. A non-U.S./non-European Group tournament that has not had a prize money adjustment under the preceding section may elect on or before four (4) months prior to the tournament to pay on-site prize money in local currency. If on-site prize money is paid in a specific non-U.S. currency, then it shall be paid on the basis of the Official ATP Exchange Rate. The Official ATP Exchange Rate is established six (6) months before the tournament and is based on the average of the preceding six (6) months. The ATP shall provide each tournament paying on-site prize money in a specific non-U.S. currency the appropriate Official ATP Exchange Rate.

The ATP will determine to what extent, if any, there is a fluctuation in the local currency exchange rate compared with the Official ATP Exchange Rate. There will be no adjustment in the Official ATP Exchange Rate if the local currency exchange rate determined by the ATP on the entry deadline of the tournament has changed from the Official ATP Exchange Rate by an amount that is less than five percent (5%). An adjustment will be made to the Official ATP Exchange Rate if there is a fluctuation of five percent (5%) or more, up or down. In such case, the adjusted Official ATP Exchange Rate will be one-half of the difference above/below the original Official ATP Exchange Rate.

B. The local currency election option does not apply to ATP Challenger Tour events.

#### 3.13 Late Payment

Prize money payments not received by the due dates specified herein are subject to a late charge of 2% per month.

#### 3.14 Taxes-Notice of Withholdings

Each ATP World Tour and ATP Challenger Tour tournament is required to give at least ninety (90) days notice to the ATP of the percentage of the applicable player income tax deduction. No other tax deduction(s) will be permitted from the on-site prize money paid to a player. Tournaments are responsible for any additional taxes imposed. Each tournament is responsible for remitting withholding tax.

### III. FINANCIAL

#### 3.15 Withholding From Prize Money

- A. Each ATP World Tour and ATP Challenger Tour tournament shall withhold from prize money only a player's applicable income tax deduction, non-member service fee, fines, advances and other ATP designated expenses.
- B. Each ATP World Tour and ATP Challenger Tour tournament shall document the player income tax deduction, if any, and provide players on-site with a withholding income tax receipt.
- C. When a fine is deducted from a player's prize money paid in a currency other than the assessed currency, the exchange rate used (on the day the fine is deducted) by the ATP World Tour and ATP Challenger Tour tournament for the payment of prize money shall be applicable to the payment of the fine.

#### 3.16 Prizes and Non-Cash Awards

- A. In addition to on-site prize money, each ATP World Tour tournament may give to each singles and doubles winner during the on-site awards presentation one (1) non-cash award or prize plus a trophy. Non-cash awards or prizes valued over \$5,000 must be approved by the President no later than forty-two (42) days prior to the tournament and can be offered for results in that tournament only.
- B. All non-cash awards or prizes must be the product of, or service provided by, a principal tournament sponsor.
- C. Pre-existing tournament sponsorship agreements made before 1993 for non-cash awards or prizes are exempt until the expiration of such agreements. The tournament must notify the appropriate ATP Regional Office of such non-cash awards or prizes forty-two (42) days prior to the tournament.
- D. Tournaments may not pay travel expenses without special written permission from the ATP.

#### 3.17 Release from Financial Commitment

- A. Each ATP World Tour tournament is required to pay its financial commitment for each calendar year tournament.
- B. No refund shall be made for any sums paid whether or not the event is actually held, unless the ATP in its sole discretion determines that extraordinary circumstances exist justifying such action.

#### 3.18 Tournament Financial Information

- A. All ATP World Tour tournaments are required to provide every two years accurate and complete actual and projected (two succeeding years) financial and other relevant information as requested by an independent consultant appointed by the ATP Board of Directors (Consultant), and otherwise provide reasonable cooperation to Consultant, including, if requested, permitting Consultant to undertake reasonable steps to verify the accuracy of tournament financial data, for the sole purpose of enabling Consultant to provide group tournament data and its evaluation of such data to the ATP Board of Directors.

### III. FINANCIAL

- B. Consultant will be instructed not to provide to ATP or its staff, except for the CFO and President, individual tournament information or any information that could reasonably lead to the calculation of individual tournament information and the matching of the information to a particular tournament.
- C. Any tournament that fails to comply with this rule shall be subject to an annual fine in an amount up to a maximum of one half of a respective tournament's Fee Obligation for that year not to exceed \$50,000. The President shall recommend any such fine after completion of an investigation into the circumstances that lead to the failure to comply. All fines shall be subject to approval by the ATP Board of Directors.
- D. A tournament may petition the ATP Board for an exemption from complying with this rule. The ATP Board will consider such petitions that demonstrate clearly that a particular tournament's organization/financial structure is such that it is not permitted to provide the information, or the requested financial information, when combined with other tournaments, will result in incorrect or misleading implications.

## IV. WORLD CHAMPIONSHIPS

### 4.01 Barclays ATP World Tour Finals - Singles

#### A. Competition Format

The tournament shall be a singles round robin format with eight (8) players. There shall be two (2) groups of four (4) players each with eight (8) seeds to be determined by the South African Airways ATP Rankings on the Monday after the last ATP World Tour tournament of the calendar year. All matches shall be the best of three (3) tie-break sets, including the final. The round robin shall determine the four (4) players for the semifinals with the format thereafter being a single elimination competition.

#### B. Entries

- 1) **Selection List.** The selection list for the event shall be:
  - a) The top seven (7) players in the South African Airways ATP Rankings as of the Monday after the last ATP World Tour tournament of the calendar year; followed by
  - b) Up to two (2) Grand Slam winners of that year, in order of their positions, positioned between eight (8) and twenty (20) in the South African Airways ATP Rankings as of that Monday; followed by
  - c) Players positioned eight (8) and below in the South African Airways ATP Rankings as of that Monday.
- 2) **Direct Acceptances.** The top eight (8) players in the selection list shall qualify for the event as direct acceptances. Participation is mandatory, and all qualified players shall be entered. All direct acceptances must be at the tournament site to attend the official pre-tournament media conference and must be available for play through the completion of the round robin competition and the knock-out competition if eligible.
- 3) **Withdrawal.** Any withdrawal, before the official pre-tournament media conference starts, shall be replaced by the next highest positioned player on the selection list, who shall be qualified as a direct acceptance.
- 4) **Alternate(s).**
  - a) The next highest positioned player on the selection list (who is not a direct acceptance at the time of the official pre-tournament media conference) shall be designated as the alternate and shall replace any player who subsequently withdraws. The alternate must appear at the official pre-tournament media conference and remain available through the start of the last scheduled round robin match.
  - b) Additional alternates may be selected by the ATP to fill the draw, based on the selection list, upon terms satisfactory to the ATP. Participation of such additional alternates is not mandatory.
  - c) The alternate(s) is eligible to play in the single elimination competition and to receive points and prize money if he qualifies.
  - d) If the alternate(s) does not play in the draw, then a fee shall be paid to the alternate(s). If the alternate(s) is inserted for the second or third round robin match, then he shall receive the alternate fee plus any prize money and points won. If the alternate(s) replaces a player that does not compete in

## IV. WORLD CHAMPIONSHIPS

his first round robin match, the alternate(s) becomes a direct acceptance and does not receive the alternate fee.

### C. Failure To Participate in the Barclays ATP World Tour Finals

- 1) If a player, qualified for the Barclays ATP World Tour Finals as a direct acceptance or designated as the alternate, fails or refuses to participate in this event, except for bona fide injury or other reason which constitutes good cause, the player shall not be in good standing.
- 2) All direct acceptances and the alternate must appear at the site of the event(s) as determined by the ATP and participate in the pre-tournament media conference.

Failure to appear shall result in a penalty of five percent (5%) of total ATP prize money earned during the ATP circuit year.

### D. Order of Play

#### Round Robin

- 1) The field shall be divided into two (2) groups of four (4) players each. The top-seeded player shall be placed in Group "A" and the second-seeded player shall be placed in Group "B". Players seeded three (3) and four (4), five (5) and six (6), and seven (7) and eight (8), shall then be drawn in pairs with the first drawn placed into Group "A."
- 2) Each player shall play every other player in his group to determine the top two (2) players in each group.
- 3) The final standings of each group shall be determined by the first of the following methods that apply:
  - a) Greatest number of wins.
  - b) Greatest number of matches played.  
Comment: 2-1 won-loss record beats a 2-0 won-loss record; a 1-2 record beats a 1-0 record.
  - c) Head-to-head results if only two (2) players are tied.
  - d) If three (3) players are tied, then:
    - i) If three (3) players each have one (1) win, a player having played less than all three (3) matches is automatically eliminated and the player advancing to the single elimination competition is the winner of the match-up of the two (2) players tied with 1-2 records; or
    - ii) Highest percentage of sets won; or
    - iii) Highest percentage of games won; or
    - iv) The player positions on the South African Airways ATP Rankings as of the Monday after the last ATP World Tour tournament of the calendar year.
  - v) If (i), (ii), (iii) or (iv) produce one (1) superior player (first place), or one (1) inferior player (third place), and the two (2) remaining players are tied, the tie between those two (2) players shall be broken by head-to-head record.  
**Comment 1:** 1 player has 3 wins and the other 3 players have 1 win. Of the 3 players with 1 win, 1 player has only played in 2 matches while the other 2 players have played 3 matches. The player who has only played 2 matches is eliminated and then the 2 remaining players revert back

## IV. WORLD CHAMPIONSHIPS

to head-to-head results with the winner of their match advancing to the semi-finals.

**Comment 2:** 1 player has 3 wins and the other 3 players have 1 win and they all have played 3 matches. The tie-break for % of sets won has 1 player with a better % than the other two. This player advances to the semi-final round.

**Comment 3:** 3 players have 2 wins and the other player has 0 wins. The player with 0 wins is eliminated. Of the 3 players with 2 wins, they are ordered by their % of sets won. This produces a 1, 2 & 3 order and the players finishing 1 and 2 move to the semi-final round and the player finishing 3 in % of sets won is eliminated. The player with the best % of sets won is the winner of the group.

**Comment 4:** 3 players have 2 wins and the other player has 0 wins. The player with 0 wins is eliminated. Of the 3 players with 2 wins, 1 player's sets won-loss is 5-2 for 71.43%; the other 2 players both have a 4-3 record in sets for 57.14%. In this case there is 1 superior player (71.43%) and the remaining 2 players are tied; it now reverts to the head to head result of the 2 remaining players with the winning player advancing as group runner-up.

**Comment 5:** 3 players have 2 wins and the other player has 0 wins. The player with 0 wins is eliminated. Of the 3 players with 2 wins, 2 have set won-loss records of 5-3 (62.5%) while the other player is 4-3 (57.14%). In this case we have 1 inferior player (57.14%) and he is eliminated. The remaining two players both advance to the semi-finals with the winner of their head-to-head match advancing as the group winner.

**Comment 6:** 3 players have 2 wins and the other player has 0 wins. The player with 0 wins is eliminated. Of the 3 players with 2 wins, all have played 3 matches and all 3 have set won-loss records of 5-4 (55.56%). In this case we move to % of games won. The % of games won breaks down like this: 44-40 for 52.38%, 45-43 for 51.14% and 44-43 for 50.57%. This produces a 1, 2 and 3 order of the group and the number 1 player in % of games won is the group winner while the player finishing 2nd in % of games won advances to the semi-finals as the group runner-up. The player with the 3rd best % of games won is eliminated.

- 4) In applying the tie-breaking procedures, a conduct default or retirement shall count as a straight-set win or loss. However, games won or lost in matches with the defaulting or retiring player shall not be counted in the application of subsection 3.d. (iii) above. A player who retires during the round robin because of illness or injury may continue in the competition if it is approved by the tournament doctor.

**Comment:** This prevents a scenario where a player knows he only needs to win 1 set to qualify for the semi-finals from retiring once he has won a set.

- 5) Any player who is defaulted pursuant to the ATP Code during the round robin competition shall be defaulted from all other matches in the Championship and the ATP default provisions shall apply, except for the following circumstances:
  - a) The loss of physical condition; or
  - b) Dress and Equipment.
- 6) Any player who withdraws from any round robin match after the first round shall not be eligible for the single elimination competition.

## IV. WORLD CHAMPIONSHIPS

### E. Single Elimination Competition

- 1) The winner of each group shall be placed in separate semifinal brackets. The runner-up of each group shall be placed in the semifinal bracket with the winner of the opposite group.
- 2) The event shall be completed with a single elimination competition for the semifinals and final.
- 3) There shall be no playoff for the third-and fourth-place positions.

### F. Prize Money and Points

Final standings at the end of the tournament shall determine the prize money and South African Airways ATP Rankings (singles) points earned.

## 4.02 Barclays ATP World Tour Finals - Doubles

### A. Competition Format

The tournament shall be a doubles round robin format with eight (8) teams. There shall be two (2) groups of four (4) teams each with eight (8) seeds to be determined by the 2012 ATP Doubles Team Rankings on the Monday after the last ATP World Tour tournament of the calendar year. All matches shall be two (2) tie-break sets with a deciding Match Tie-break (10 point) at one (1) set all. The round robin shall determine the four (4) teams for the semifinals with the format thereafter being a single elimination competition.

### B. Entries

- 1) **Selection List.** The selection list for the event shall be:
  - a) The top 7 teams in the 2012 ATP Doubles Team Rankings as of the Monday after the last ATP World Tour tournament of the calendar year; followed by
  - b) Up to two (2) Grand Slam winners of that year, in order of their positions, positioned between eight (8) and twenty (20) in the 2012 ATP Doubles Team Rankings as of that Monday; followed by
  - c) Teams positioned eight (8) and below in the 2012 ATP Doubles Team Rankings as of that Monday.
- 2) **Direct Acceptances.** The top eight (8) teams in the selection list shall qualify for the event as direct acceptances. Participation is mandatory, and all qualified teams shall be entered. All direct acceptances must be at the tournament site to attend the official pre-tournament media conference and must be available for play through the completion of the round robin competition and the knock-out competition if eligible.
- 3) **Withdrawal.** All eligible teams shall be entered by the ATP; however, teams may withdraw through the Monday after the last ATP World Tour tournament of the year. Any withdrawal, before the official pre-tournament media conference starts, shall be replaced by the next highest positioned team on the selection list, who shall be qualified as a direct acceptance.
- 4) **Alternate(s).**
  - a) On the Monday after the last ATP World Tour tournament of the year, the next highest positioned team shall be asked to confirm its status as the alternate

## IV. WORLD CHAMPIONSHIPS

team. Alternate team(s) may be selected by the ATP to fill the draw upon terms satisfactory to the ATP. Any withdrawal after the official pre-tournament media conference through the start of the last scheduled round robin match shall be filled with the alternate team(s). The alternate team must appear at the official pre-tournament media conference and remain available through the start of the last scheduled round robin match.

- b) Additional alternate teams may be selected by the ATP to fill the draw, based on the selection list, upon terms satisfactory to the ATP. Participation of such additional alternate teams is not mandatory.
- c) The alternate team(s) is eligible to play in the single elimination competition and to receive points and prize money if they qualify.
- d) If the alternate team(s) does not play in the draw, then a fee shall be paid to the alternate team(s). If the alternate team(s) is inserted for the second or third round robin match, then they shall receive the alternate fee plus any prize money and points won. If the alternate team(s) replaces a team that does not compete in their first round robin match, the alternate team(s) becomes a direct acceptance and does not receive the alternate fee.

### C. Order of Play

#### Round Robin

- 1) The field shall be divided into two (2) groups of four (4) teams each. The top-seeded team shall be placed in Group "A" and the second-seeded team shall be placed in Group "B". Teams seeded three and four, five and six, and seven and eight, shall then be drawn in pairs with the first drawn placed into Group "A".
- 2) Each team shall play every other team in their group to determine the top two (2) teams in each group.
- 3) The final standings of each group shall be determined by the first of the following methods that apply:
  - a) Greatest number of wins.
  - b) Greatest number of matches played.  
**Comment:** 2-1 won-loss record beats a 2-0 won-loss record; a 1-2 record beats a 1-0 record.
  - c) Head-to-head results if only two (2) teams are tied.
  - d) If three (3) teams are tied, then:
    - i) If three (3) teams each have one (1) win, a team having played less than all three (3) matches is automatically eliminated and the team advancing to the single elimination competition is the winner of the match-up of the two (2) teams tied with 1-2 records; or
    - ii) Highest percentage of sets won; (Winning the MTB counts as one (1) set won); or
    - iii) Highest percentage of games won. (Winning the MTB counts as one (1) game won); or
    - iv) The team positions on the 2012 ATP Doubles Team Rankings as of the Monday after the last ATP World Tour tournament of the calendar year.
    - v) If (i), (ii), (iii) or (iv) produce one (1) superior team (first place), or one (1) inferior team (third place), and the two (2) remaining teams are tied, the tie between those two (2) teams shall be broken by head-to-head record  
**Comment 1:** 1 team has 3 wins and the other 3 teams have 1 win. Of the

## IV. WORLD CHAMPIONSHIPS

3 teams with 1 win, 1 team has only played in 2 matches while the other 2 teams have played 3 matches. The team who has only played 2 matches is eliminated and then the 2 remaining teams revert back to head-to-head results with the winner of their match advancing to the semi-finals.

**Comment 2:** 1 team has 3 wins and the other 3 teams have 1 win and they all have played 3 matches. The tie-break for % of sets won has 1 team with a better % than the other two. This team advances to the semi-final round.

**Comment 3:** 3 teams have 2 wins and the other team has 0 wins. The team with 0 wins is eliminated. Of the 3 teams with 2 wins, they are ordered by their % of sets won. This produces a 1, 2 & 3 order and the teams finishing 1 and 2 move to the semi-final round and the team finishing 3 in % of sets won is eliminated. The team with the best % of sets won is the winner of the group.

**Comment 4:** 3 teams have 2 wins and the other team has 0 wins. The team with 0 wins is eliminated. Of the 3 teams with 2 wins, 1 team's sets won-loss is 5-2 for 71.43%; the other 2 teams both have a 4-3 record in sets for 57.14%. In this case there is 1 superior team (71.43%) and the remaining 2 teams are tied; it now reverts to the head to head result of the 2 remaining teams with the winning team advancing as group runner-up.

**Comment 5:** 3 teams have 2 wins and the other team has 0 wins. The team with 0 wins is eliminated. Of the 3 teams with 2 wins, 2 have set won-loss records of 5-3 (62.5%) while the other team is 4-3 (57.14%). In this case we have 1 inferior team (57.14%) and this team is eliminated. The remaining two teams both advance to the semi-finals with the winner of their head-to-head match advancing as the group winner.

**Comment 6:** 3 teams have 2 wins and the other team has 0 wins. The team with 0 wins is eliminated. Of the 3 teams with 2 wins, all have played 3 matches and all 3 have set won-loss records of 5-4 (55.56%). In this case we move to % of games won. The % of games won breaks down like this: 44-40 for 52.38%, 45-43 for 51.14% and 44-43 for 50.57%. This produces a 1, 2 and 3 order of the group and the number 1 team in % of games won is the group winner while the team finishing 2nd in % of games won advances to the semi-finals as the group runner-up. The team with the 3rd best % of games won is eliminated.

- 4) In applying the tie-breaking procedures, a conduct default or retirement shall count as a straight-set win or loss. However, games won or lost in matches with the defaulting or retiring team shall not be counted in the application of subsection 3.d. (iii) above. A team who retires during the round robin because of illness or injury may continue in the competition if it is approved by the tournament doctor.

Comment: this prevents a scenario where a team knows he only needs to win 1 set to qualify for the semi-finals from retiring once he has won a set.

- 5) Any team who is defaulted pursuant to the ATP Code during the round robin competition shall be defaulted from all other matches in the Championship and the ATP default provisions shall apply, except for the following circumstances:
- The loss of physical condition; or
  - Dress and Equipment.
- 6) Any team who withdraws from any round robin match after the first round shall not be eligible for the single elimination competition.

## IV. WORLD CHAMPIONSHIPS

### D. Single Elimination Competition

- 1) The winner of each group shall be placed in separate semifinal brackets. The runner-up of each group shall be placed in the semifinal bracket with the winner of the opposite group.
- 2) The event shall be completed with a single elimination competition for the semifinals and final.
- 3) There shall be no playoff for the third-and fourth-place positions.

### E. Prize Money and Points

Final standings at the end of the tournament shall determine the prize-money and ATP Doubles Rankings points earned.

## 4.03 ATP World Tour Team Championship

### A. Competition Format

#### 1) Round Robin Competition

- a) The official ATP World Tour Team Championship is a competition for eight (8) teams, each team composed of a minimum of three (3) players and a maximum of five (5) players from the same country.
- b) A player's citizenship as of the year-end (December 5, 2011) South African Airways ATP Rankings (singles) and ATP Doubles Rankings shall determine a player's country. This restriction will affect the seven (7) directly accepted teams only.
- c) The competition shall be a round robin format with two (2) groups of four (4) teams each with entries to be determined by the year-end (December 5, 2011) South African Airways ATP Rankings (singles) positions of the top two (2) singles players on each team.
- d) Each team shall play each other in its group to determine the top team in each group. The top team in each group shall play in the final to determine the ATP World Team Champion.

#### 2) Daily Order of Play - The Tie

- a) A tie consists of two (2) singles matches and one (1) doubles match. The two (2) singles matches shall be played first and the order of matches shall be determined by the supervisor/referee. The doubles match must be played after the two (2) singles matches. All singles matches shall be the best of three (3) tiebreak sets.  
All doubles matches shall be two (2) tie-break sets with a deciding Match Tie-Break (10 point) at one (1) set all. Doubles matches shall be decided using the No-Ad scoring method.
- b) For each tie, the highest-positioned (hereafter, number one) singles players from each team shall compete against each other and the second-positioned (hereafter, number two) singles players from each team shall compete against each other. The order of positions in each team shall be based upon the South African Airways ATP Rankings (singles) dated approximately six (6) days prior to the start of the event. Players not able to play singles and/or doubles because of an ATP Challenger Tour or ATP World Tour event may have their singles and/or doubles match substituted by another team member.

## IV. WORLD CHAMPIONSHIPS

- c) Upon the completion of the doubles match, the winner of the tie shall be the team that wins at least two (2) of the three (3) matches.

### 3) Determination of Finalist Teams

- a) The teams shall be ranked within each round robin in the following manner:
- i) The team that has won the most ties is ranked highest.
  - ii) In a tie between two (2) teams, the team that won their head-to-head tie in their group shall be ranked higher.
  - iii) In a tie between three (3) teams, the following shall apply:
    1. The team that has won the most matches is ranked highest.
    2. The team that has the highest percentage of sets won is ranked highest.
    3. The team that has the highest percentage of games won is ranked highest.
    4. If (1), (2) or (3) produce one superior team (first place), or one inferior team (third place), and the two remaining teams are tied, the tie between those two teams shall be broken by head-to-head record.
  - b) In the event that after the conclusion of the round robin competition, one (1) of the two (2) qualified teams is unable to appear, then the next highest ranked team selected from the same group as the withdrawing team shall compete in the final tie.
  - c) Unplayed, defaulted and retired matches shall be scored as completed for purposes of sets and games. (i.e., 43 retired = 63 60).
  - d) For the purpose of scoring the number of games a doubles team has won or lost, the Match Tie-Break shall be scored as 76.

- 4) **Hotel Accommodations.** Accommodations for the teams [maximum of four (4)] rooms per team shall be free of charge throughout the event, starting on the Thursday prior to the start of the competition.

### 5) Round Robin Composition

- a) The teams shall be positioned from 1 to 8 in accordance with the South African Airways ATP Rankings (singles) dated six (6) days prior to the start of the competition. Team 1 shall be the team with the highest combined singles ranking. Only the rankings of the 2 players that have qualified the team based on their year-end South African Airways ATP Ranking (singles) shall be used for the seeding process. Protected rankings may not be used for seeding purposes. If one or both qualifying team members have to withdraw before the draw, the latest rankings of the next 2 highest ranked team members shall be used to determine the position of that team. Team 2 shall be the team with the second highest combined singles ranking, and so on. In the case where two (2) teams have the same combined ranking, then the team with the highest positioned singles player shall be selected first.
- b) Team 1 shall be placed in one round robin group, and Team 2 shall be placed in the other round robin group. These groups shall be named Red and Blue.
- c) Placement of the other teams shall be determined by the drawing of lots; the first drawn between Teams 3 and 4 shall be placed in the Red Group and the second drawn in the Blue Group. This procedure is repeated for Teams 5 and 6 and for Teams 7 and 8.

## IV. WORLD CHAMPIONSHIPS

### B. Prize Money

#### 1) Breakdown

- a) Team Prize Money will be as follows:

Winning Team	first place	260,000 €
Finalist Team	second place	168,000 €
2nd in Group	per team	75,000 €
3rd in Group	per team	50,000 €
4th in Group	per team	29,000 €

- b) Player Doubles Bonus Money (for each player) will be as follows:

Player winning most total doubles matches	10,700 €
Player winning 2nd place	9,000 €
Player winning 3rd place	6,200 €
Player winning 4th place	3,500 €
Player winning 5th place	1,800 €
Player winning 6th place	950 €

- i) The Player Doubles Bonus shall be awarded to the players who have won the most doubles matches with the priority given to the most matches played in the case of a tie. For example, 3 wins/0 losses; 2 wins/1 loss; 2 wins/0 losses; 1 win/2 losses; 1 win/1 loss; 1 win/0 loss.

- ii) Ties shall be broken in the same manner as team ties. In the case of the players still being tied, the prize money between these players shall be divided equally.

- c) Doubles Final Match Prize Money. The doubles team winning the match in the final shall receive an additional 8,500 € (4,250 € per player).

- 2) **Team Prize Money Distribution.** The Team prize money Distribution Formula shall be used if the two (2) team members that qualify the team cannot agree on their own breakdown. The year-end (December 5, 2011) South African Airways ATP Rankings (singles) positions shall be used for the following formulas:

- a) Third player of the team who is on-site will receive:

30% of total team prize money	if positioned	1-50
25% of total team prize money	if positioned	11-25
20% of total team prize money	if positioned	26-50
15% of total team prize money	if positioned	51-100
10% of total team prize money	if positioned	101+



## IV. WORLD CHAMPIONSHIPS

- b) The top two (2) players will divide the remainder of the total team prize money as follows:

Difference in Positions	First Player	Second Player
Less than 6	50%	50%
6 to 10	55%	45%
11 to 25	60%	40%
26 to 50	70%	30%
More than 50	80%	20%

- c) If a fourth player and/or fifth player is/are included on the team, then every player should give the same percentage of prize money to such player as determined by the tournament committee.

### 3) Travel.

- a) Each nominated team captain present on-site shall be paid 2,650 €.  
b) The two finalist captains shall receive 3,725 € each.

- 4) **Tax.** Players and Captains shall be subject to income tax deductions excluding VAT, which shall be paid by the tournament.

### C. Schedule of Play

The following is the schedule of play unless otherwise determined by the tournament committee and supervisor:

- 1) The eight teams shall play matches on the first six days to determine the two winners of the round robin groups. A team match will be played over one or two days as determined by the tournament committee and supervisor. For the second round robin match (tie) the winners of the first match (tie) shall be placed against the losers of the first match (tie) in their group.
- 2) The schedule of the first day of play (Sunday) shall be made at 5 pm on Saturday unless unforeseen circumstances, e.g. results from other events, etc. make it necessary to postpone the release.
- 3) All players and captains must be available for play on Sunday. The determination of matches for play on the first day of the event shall be based on the availability of players after considering the results from the prior week's ATP World Tour tournaments. Players may be required to play the day following a semi-final or final of an ATP Challenger Tour or the ATP World Tour Masters 1000 Rome.
- 4) The selection of the team singles pairings shall be made automatic as determined by the South African Airways ATP Rankings (singles) on the Monday prior to the start of the competition
- 5) The final shall be held on the 7th day (Saturday) of the tournament.
- 6) In the event of rain and/or unforeseen circumstances, the matches shall be moved to an indoor court with the same red clay surface as the Rochusclub courts.
- 7) The tournament's committee and/or supervisor reserves the right to hold matches indoors, change the schedule of play, alter starting times and make other changes deemed necessary for the smooth running of the competition.

## IV. WORLD CHAMPIONSHIPS

### D. Teams

- 1) **Direct Acceptance.** The teams shall be selected and entered in the following manner:

The first seven (7) team entrants, plus teams on the alternate list, shall be based on the highest combined singles ranking of the top 2 players representing that country as of the year-end (December 5, 2011) South African Airways ATP Rankings (singles). Protected rankings as of the year-end South African Airways ATP Rankings (singles) can be used for entries and to determine the number one player of a team. In the case where two (2) teams have the same combined ranking, the team with the highest positioned singles player shall be selected first.

### 2) Alternates

- a) The combined rankings of the seventh (7th) ranked team shall be the initial cut-off at the time the year-end South African Airways ATP Rankings (singles) will be published.
- b) If after being contacted by the ATP or the tournament, one or both of the 2 qualifying players for the same country do not accept the entry the next highest ranked player(s) of that country as of the year-end South African Airways ATP Rankings (singles) shall be used to determine a new combined team ranking. If that new combined team ranking would still rank that team within the top seven (7) teams it shall remain as one of the seven (7) qualified teams. If the new combined ranking would rank them outside the top seven (7) teams it shall become one of the alternate teams and the former number eight (8) team shall take the vacant spot.

### 3) Wild Card Team

- a) There shall be one (1) wild card team selected by the tournament committee. The country selected must be established and recognized at the time of selection. Players for the wild card team shall be determined by a method accepted by the tournament committee at the time of the wild card selection.
- b) The wild card team players' South African Airways ATP Rankings (singles) at the time of nomination shall determine the order of the players. Protected rankings as of the time of the wild card nomination can be used to determine the number one player of a team.
- c) Should the previously awarded wild card team become a direct acceptance prior to the 42 day wild card nomination deadline, the team members and the rank order of the players within the team shall be decided using the same procedures as the other Direct Acceptance teams based on the year-end (December 5, 2011) South African Airways ATP Rankings (singles), including possible year-end protected rankings.
- d) The wild card team shall be finalized 42 days prior to the Monday of the tournament week. Any vacancy created by the withdrawal of the wild card team after the wild card has been finalized may be filled by a new wild card team; or, by the next team on the acceptance list based on the year-end (December 5, 2011) South African Airways ATP Rankings (singles).
- e) Once finalized, the wild card team is removed from the direct acceptance alternate list.

### 4) Acceptance of Nomination

- a) Players shall be sent written notification of qualification when their respective team has been nominated.

## IV. WORLD CHAMPIONSHIPS

- b) Players must notify in writing the ATP or the Rochusclub, Dusseldorf, of their acceptance of entry; notification of acceptance may be given to any ATP Regional Office or tour manager.
  - c) The acceptance deadline for entry is Monday, March 26, 2012 (the middle Monday of Miami).
  - d) Failure to notify in writing the ATP or the Rochusclub either of a player or team's acceptance shall result in the next player or team being selected to participate in the competition.
- 5) **Qualification.** In order to qualify for the competition, a team that has accepted entry must comply with the following requirements:
- a) The team is composed of the two (2) highest positioned and eligible players based on the year-end (December 5, 2011) South African Airways ATP Rankings (singles).
  - b) A third player with a South African Airways ATP Rankings (singles or doubles) must be named by the #1 player at least forty-two (42) days prior to Monday of the tournament week, and must be on-site for the competition. Priority should be given to the highest eligible player available.
  - c) If one (1) of the three (3) members withdraws because of injury or illness, then the team captain must immediately nominate a fourth player to be on-site for the team's next match.
  - d) A fourth player must be nominated and a fifth player may be named to the team at the 10:00 a.m. Sunday Captains' Meeting, to be eligible as a team member or substitute at any time. If the fourth and/or fifth player is named after the Captain's Meeting the player is eligible only as a substitute for an injured or ill player. The fourth and/or fifth player does not have to be on-site unless one of the three (3) members withdraws because of injury or illness.
  - e) In the case of illness, injury or unforeseen circumstances, the supervisor may allow the team captain to nominate a substitute player during the competition.
- 6) **Withdrawal of Entry**
- a) The deadline for withdrawal of entry for a player shall be forty-two (42) days prior to the Monday of the tournament week. No player shall withdraw from the competition for any reason after the withdrawal deadline, except as provided above in Requirement of Teams.
  - b) Violation of this section shall be penalized consistent with the player Code of Conduct.

### E. Team Captain

#### 1) Designation of Captain

- a) The number one player on each team shall appoint a captain, forty-two (42) days prior to the Monday of the tournament week, provided such person meets one (1) of the following criteria:
  - i) qualified coach of a national federation; or
  - ii) A member of the ATP Coaches Division; or
  - iii) A Division I player member.
- b) In the event the captain is not on-site or not available, the highest positioned player on hand shall assume the role of captain.
- c) The captain must be on-site for the duration of that team's participation in the competition. In the event the captain is not available, the #1 player who qualified the team, the #2 player or a player's coach will assume the duties of the

## IV. WORLD CHAMPIONSHIPS

captain. On the Saturday prior to the start of the competition this should also apply but not be limited to the nomination of the teams for first day of play. The captain is to be confirmed to the tournament committee forty-two (42) days prior to the Monday of the tournament week. The captain/coach shall be subject to the player Code of Conduct.

#### 2) Duties of Captain.

- The duties of the captain are as follows:
- a) Name the third and/or fourth team member;
  - b) Act as official representative for his respective team;
  - c) Attend all team meetings; and
  - d) Nominate an alternative coach to sit on-court.
  - e) If for any reason the captain cannot assume his duties as a captain, he must nominate an alternate captain.

#### 3) Player Designations

- a) The top two (2) singles players from each country at time of team qualification and/or wild card selection are automatically designated for each tie. Change may be allowed for reasons of ranking, medical conditions, unforeseen circumstances or as approved by the ATP supervisor. These changes must be finalized before the order of play is released. Team changes after the release of the order of play are only allowed for medical conditions and unforeseen circumstances.
- b) If the number one player withdraws from a tie before the order of play is released, the number 2 player takes the number one spot and the vacant number 2 spot is filled by another team member. If the number one player withdraws after the release of the order of play, the vacant number one spot shall be filled by another team member.

The withdrawing player shall not be eligible to compete for the remainder of that tie (singles or doubles), unless;

- i) The withdrawal was made before the order of play has been released for that tie. In that case the withdrawing player may be nominated to play doubles on that same day if declared fit by the tournament doctor; or,
  - ii) If the doubles is scheduled for the following day the withdrawing player may be added to the doubles team regardless of his withdrawal time if declared fit by the tournament doctor.
- c) The team captains must give in writing the names of their doubles team to the referee and opposing captain no later than fifteen (15) minutes after completion of the last singles match. The doubles team may be chosen from any players named to the team.
  - d) There shall be a maximum of one forty-five (45) minute interval between the end of the last singles match and the start of the doubles match if one or more of the doubles players competed in the last singles match. If none of the players designated for the doubles has competed in the last singles match, the doubles shall start thirty (30) minutes after completion of the last singles match.
  - e) If his team has no singles matches on that day, then the captain must name the doubles team per the following deadlines:
    - i) If scheduled first match of the day: one (1) hour before the scheduled start of play.
    - ii) If scheduled second match: the deadline shall be the exact time of the first scheduled match on that court.

## IV. WORLD CHAMPIONSHIPS

- iii) If scheduled third: the deadline shall be one (1) hour after the scheduled start of play for the first match on that court or one (1) hour prior to the scheduled “not before” time of that third doubles.
- iv) If scheduled fourth: the deadline shall be one (1) hour prior to the scheduled “not before” time for that match.
- f) The team captain may not replace a player except in the case of illness, injury or unforeseen circumstances approved by the ATP supervisor. Illness or injury must be documented by the official doctor of the WTC.
  - i) Any player who withdraws from the singles after the order of play is released shall not be eligible for doubles on that same day.
  - ii) in the event of match changes, the supervisor may allow reasonable time adjustments in the schedule.
- g) In the event of a conduct penalty, the supervisor after consultation with the tournament committee may decide to remove the offending player(s) for the remainder of the tie or event.

### F. Jurisdiction Governing the Competition

- 1) The competition is sanctioned and recognized by the ATP, Inc.
- 2) All players, captains and coaches who enter and compete in the competition agree to be subject to the Rules and Regulations of the ATP, including, but not limited to, the Code of Conduct, as well as the Rules of Tennis.
- 3) The tournament committee, supervisor and referee shall determine and resolve all questions not considered in these Rules and Regulations.

## V. PERSONNEL

### 5.01 Tournament Director

#### A. Appointment

- 1) A tournament may change the tournament director named in the tournament application by submitting the proposed change to the ATP Board for approval.
- 2) The ATP Board may require a tournament to change the tournament director upon a finding that such tournament director has failed to or refused to comply with any provision of the ATP’s rules and regulations.

#### B. Responsibilities

Each tournament director shall:

- 1) Act in cooperation with the ATP staff on-site.
- 2) Be responsible for tournament compliance with all rules and regulations.
- 3) Not go on court during a match (including warm-up) or otherwise become involved in any Code of Conduct matter.

### 5.02 Tour Manager

#### A. Appointment

The ATP shall provide a tour manager for each ATP World Tour tournament.

#### B. Responsibilities

- 1) The tour manager shall be present for all sign-ins.
- 2) The tour manager shall be present at the making of all draws.
- 3) The tour manager shall act as the player representative for all aspects of the tournament, including as a member of the scheduling committee.

### 5.03 PR & Marketing

#### A. Appointment

- 1) The ATP will provide a PR & Marketing representative for each ATP World Tour tournament to coordinate advance publicity, help organize facilities and provide media assistance on-site.

#### B. Responsibilities

- 1) The PR & Marketing representative shall liaise with journalists, players and sponsors.
- 2) The PR & Marketing representative shall organize and supervise post-match press conferences.
- 3) The PR & Marketing representative shall coordinate exclusive interviews.

## V. PERSONNEL

- 4) The PR & Marketing representative shall provide statistical and biographical information to journalists.
- 5) The PR & Marketing representative shall disseminate information to international journalists.
- 6) The PR & Marketing representative shall suggest storylines to journalists.

### 5.04 Doctor, Physiotherapist and Massage Therapist

#### A. ATP World Tour Tournaments

- 1) **Tournament Doctor.** Beginning with the qualifying competition, it is the responsibility of each ATP World Tour tournament to provide on-site during the entire tournament an English-speaking doctor who specializes in sports medicine, unless otherwise approved by the ATP's Medical Services Committee.
- 2) **Physiotherapist.** The ATP shall provide a physiotherapist for all tournaments except that the ATP may require assistance from a tournament to provide a physiotherapist for the qualifying competition.
- 3) **Massage Therapist.** It is the responsibility of each ATP World Tour tournament to provide a massage therapist.

#### B. ATP Challenger Tour Tournaments

- 1) **Tournament Doctor.** Each ATP Challenger Tour tournament is required to have a tournament doctor at the site or on call in proximity of the tournament site during the event. Each tournament shall send the name and address of the tournament doctor to the ATP's Medical Services Committee forty-two (42) days in advance of the tournament.
- 2) **Physiotherapist.** Each ATP Challenger Tour tournament must provide a physiotherapist for the players beginning on the first day of the qualifying competition.
- 3) **Massage Therapist.** A massage therapist should be provided whenever possible.

### 5.05 Supervisor

#### A. Assignment & Designation

##### 1) ATP World Tour Tournaments

An ATP Supervisor shall be provided by the ATP for each ATP World Tour tournament.

##### 2) ATP Challenger Tour Tournaments

The ATP may provide a supervisor for each ATP Challenger Tour tournament. If the ATP does not provide the supervisor, the on-site referee approved by the ATP shall be designated to be the supervisor.

#### B. Fees and Expenses

ATP World Tour and ATP Challenger Tour Tournaments

The ATP shall pay the fees and travel expenses of the supervisors hired by the ATP.

## V. PERSONNEL

Each tournament must provide each supervisor with single room hotel accommodations, meals and laundry. Complimentary rooms shall be in the player hotel or another hotel approved by the ATP or the supervisor.

#### C. General

The supervisor at each ATP World Tour tournament is provided by the ATP. Whenever the supervisor is not available, the supervisor shall designate an approved referee or ATP Official to assume all duties and responsibilities. (All references to supervisor includes "or his designee.")

The supervisor at each ATP Challenger Tour tournament shall be the on-site referee, approved by the ATP and provided by the tournament, unless otherwise determined by the ATP.

#### D. Responsibilities

In all ATP World Tour and ATP Challenger Tour tournaments, including ATP World Team Championship, the supervisor shall:

- 1) Act as the ATP's representative, speaking with the full authority of the ATP during the tournament.
- 2) Act as final on-site authority ensuring that the tournament is conducted fairly in accordance with the ATP's Rules and Regulations as to all matters arising that require immediate resolution at the tournament site including the evaluation of tournament compliance with Facilities and On-Site Condition requirements.
- 3) Issue player conduct fines as necessary and appropriate.
- 4) Direct, supervise, instruct and evaluate the referee, Chief of Umpires and all on-court officials, including the authority to:
  - a) Make the assignment of all chair umpires and approve all line umpires and net judge for tournament matches.
  - b) Remove a chair umpire and/or remove, rotate or replace any line umpire or net judge when necessary to improve the officiating of a match.
- 5) Make all draws for the qualifying and main draw competitions.
- 6) When weather or other conditions threaten the immediate safety of the players, spectators, officials or any other persons on the tournament site, the supervisor may suspend or postpone the match(es) until such time that in his opinion the threat to safety is no longer evident.
- 7) Decide if a court is fit for play or decide if a match should be moved to another court. The supervisor may, if necessary to eliminate the possibility of a player having to play two singles matches in one day, or if necessary to complete the event, move a match to another court, indoors or outdoors, regardless of surface.
- 8) Serve as the Chairman of the scheduling committee and make the final decision on all scheduling matters if the committee is not in agreement. Insure that the daily order of play is posted on the bulletin board and at the official hotel.
- 9) Designate a highly visible place in the general player area as the official bulletin board.
- 10) Designate a visible timepiece at a fixed location as the "Official Clock" of the tournament.

## V. PERSONNEL

- 11) Designate a specific area from which matches shall be called and determine when a match is to be called.
- 12) Maintain a continuous dialogue during the week with the tournament director and submit a report to the ATP evaluating the tournament, including attendance, and officials. The tournament director shall receive a copy of the report prior to the supervisor's departure.
- 13) Decide with the tournament director the designation of the lowest tier of seats that surround the playing area of the courts at each tournament.

### E. Clothing - ATP World Tour

The officiating uniform provided by the ATP must be worn. No other commercial branding may be applied to the uniform without prior approval from the ATP.

### 5.06 Chair Umpire

#### A. Assignment and Designation Process

- 1) ATP World Tour Tournaments. Officials required to support the tournament are as follows:

The ATP shall hire designated chair umpires as follows:

<u>Main Draw Size (Singles)</u>	<u>Total # of chair Umpires</u>
96	9
56	7
48	5
32	4
28	4

**NOTE:** In the event the tournament elects to employ the services of an electronic line calling system, the ATP will hire a review official in addition to the chair umpires as stated above.

Each tournament is required to provide supplemental chair umpires approved by the ATP for the qualifying competition as well as for some main draw matches not covered by the designated chair umpires hired by the ATP. Supplemental chair umpires must have international certification of Gold, Silver or Bronze.

- 2) **ATP Challenger Tour Tournaments.** Tournaments must hire chair umpires as specified below:
  - a) **Chair Umpires.** Each tournament shall have a minimum of three (3) designated chair umpires for the entire week, including qualifying competition, as selected and coordinated by the ATP. Under special circumstances, the ATP may require a fourth chair umpire to be hired by the tournament.
  - b) **Supplemental Chair Umpires.** Each tournament shall provide supplemental chair umpires approved by the ATP for the qualifying competition as well as for some main draw matches not covered by the designated chair umpires. Supplemental chair umpires must have certification of Gold, Silver, Bronze or White.

## V. PERSONNEL

### B. Fees and Expenses

The ATP shall pay the fees and travel expenses of the designated chair umpires and review officials (if any) hired by the ATP.

#### 1) ATP World Tour and ATP Challenger Tour Tournaments.

Each tournament must provide each designated chair umpire and review official (if any) with single room hotel accommodations, meals and laundry. Complimentary rooms shall be in the player hotel or another hotel approved by the ATP or the supervisor.

Each ATP Challenger Tour tournament shall pay a fair and reasonable fee and travel expense to each chair umpire hired by the tournament.

### C. General

Chair umpires are assigned matches by the ATP supervisor and are responsible to ensure those matches are conducted according to the rules of the ATP in order to present a professional tournament.

### D. Responsibilities

- 1) Enforce all ATP Rules and Regulations and on-court procedures to ensure accuracy, fairness and safety. Ensure that the players and all on-court officials observe the rules.
- 2) The following pertain to the rules for continuous play: Have a hand held stopwatch in his possession which shall be used to time the warm-up, the time between points, the time permitted on changeovers, the time permitted during the set break and all other specified time periods designated under the provisions of any rule or regulation.
- 3) Dress uniformly with other chair umpires as prescribed by the supervisor.
- 4) If appropriate, conduct a pre-match meeting with all of the on-court officials for the match to specify court assignments and the procedures to be used for making calls, hand signals, rotation of court assignments, etc.
- 5) Ascertain prior to matches from the supervisor or the Chief of Umpires that the tournament has made appropriate arrangements for the safe escorting of players to and from the court before and after the match.
- 6) Immediately before the start of the match meet with the players to:
  - a) Verify the correct pronunciation of the players' names.
  - b) State any pertinent information (rule changes, new procedures, etc for the players.
- 7) Flip a coin in the presence of both players or teams to determine choice of serve and side at the beginning of the match prior to the warm-up. If play is suspended before the match begins, the winner of the toss may choose again before the match commences.
- 8) Determine if each player is dressed in accordance with the dress provisions of the ATP rules. Corrective action taking more than fifteen (15) minutes shall result in

## V. PERSONNEL

a default in consultation with the supervisor. An appropriate re-warm-up may be authorized.

- 9) Determine all Questions of Fact arising during the match (including the permitted five (5) minute warm-up).
- 10) Make the first determination of all Questions of Tennis Law arising during the match, subject to the right of a player to appeal to the supervisor.
- 11) Announce the score after each point in accordance with On-Court Procedures. Announcements as a minimum must be in English. If two (2) languages must be used, announce in the local language first, then English. Conversations between the chair umpire and a player can be in any language. However, if the language used is not English, then the chair umpire must be prepared to advise the other player of the nature of the discussion.
- 12) Repeat the calls of a line umpire or net judge if the call is made in a weak voice or there is a close call that must be confirmed to remove any doubt from the minds of the players.
- 13) Be responsible for any ball mark inspection on clay courts. A ball mark inspection must be made in accordance with the approved on-court procedures.
- 14) Overrule a line umpire only in the case of a clear mistake by the line umpire and only if the overrule is made promptly after the mistake is made. All overrules must be made in accordance with the approved on-court procedures. Obvious foot faults must be called by the chair umpire consistent with the procedures used for handling "clear mistakes".
- 15) Remove, rotate or replace any line umpire or net judge whenever, in the opinion of the chair umpire, it will improve the officiating of a match.
- 16) Exercise his best efforts to control the crowd. Spectator involvement is encouraged as long as the chair umpire does not determine such involvement to be deliberately distracting. Whenever the spectators are impeding the progress of the match, the chair umpire should address them respectfully and request their cooperation. The tournament announcer and security personnel may be used to assist the chair umpire after consultation with the supervisor.
- 17) Be responsible for the direction of the ball persons during the match so that they assist but do not disturb the players.
- 18) Be responsible for having the appropriate number of balls on-court for the match, for all changes of balls and for determining if a ball is fit for play. The appropriate number of ball containers should be opened and inspected sufficiently in advance of each ball change so as to avoid any delay of the match at the time of a ball change.
- 19) Complete a scorecard in accordance with the approved on-court procedures. Following the completion of a match, the scorecards or printouts are to be finalized and distributed to appropriate ATP, tournament and/or media personnel. Maintain the ATP Point Penalty Card in accordance with the approved on-court procedures.
- 20) Determine if a court continues to be fit for play. If a change in condition occurs during a match that the chair umpire considers sufficient to make the court unfit

## V. PERSONNEL

for play or if weather conditions require stoppage of play, he should stop play and immediately notify the supervisor.

- 21) Following the conclusion of the match, make a full report to the supervisor concerning all actions taken under the Code during the match. If required by the supervisor, in addition to the brief summary of the violation made on the Point Penalty Card, the chair umpire shall write a detailed statement of the incident. All reports shall be signed, dated and delivered to the supervisor.
- 22) Chair umpire responsibilities to include primary responsibility to call nets or throughs, unless otherwise assigned.
- 23) Chair umpires must promptly and accurately score matches using the handheld or other method provided by ATP. In addition, chair umpires agree not to, and shall not authorize or assist any third party to, disseminate, transmit, publish or release any match related data or information to or for any third party without the express written consent of ATP. Further, each chair umpire agrees that any and all work or data he/she collects or creates in connection with any match shall constitute a "work made for hire" and any and all rights attributable to such work shall be retained by, or if necessary automatically assigned to, ATP and its members.

### E. Clothing - ATP World Tour

The officiating uniform provided by the ATP must be worn. No other commercial branding may be applied to the uniform without prior approval from the ATP.

## 5.07 Line Umpire

### A. Assignment and Designation Process

#### 1) ATP World Tour Tournaments

Officials required to support the tournament are as follows:

Unless otherwise approved by the ATP, the following are required: A minimum of seven (7) line umpires must be provided per main draw match. A minimum of five (5) line umpires per qualifying match must be provided.

#### 2) ATP Challenger Tour Tournaments

Tournaments must hire officials as specified below:

For events offering \$75,000 or less in prize money, a minimum of three (3) line umpires shall be provided for every qualifying match and also every main draw match up until the quarterfinal. From the quarterfinal on, a minimum of five (5) line umpires shall be provided. For events offering \$100,000 or more, in prize money, a minimum of five (5) line umpires shall be provided for every main draw match up until the semifinal. From the semifinal on, a minimum of seven (7) line umpires shall be provided. The qualifying competition shall have a minimum of three (3) line umpires per match.

### B. General

Line umpires are assigned by the Chief of Umpires and are responsible for calling their assigned lines according to the ATP rules under the direct on-court supervision of the chair umpire.

## V. PERSONNEL

### C. Clothing

Clothing provided by the tournament for line umpires shall not be solid white, yellow or other colors that may interfere with the vision of the players, unless otherwise approved by the ATP. It is recommended that dark-colored clothing be avoided for outdoor tournaments played in high temperatures. Clothing should not be identical to clothing provided to the ball persons.

### D. Responsibilities

- 1) Carry out all duties in accordance with the approved procedures of the ATP.
- 2) Not catch balls or hold towels for a player.
- 3) Not leave the court without permission of the chair umpire.
- 4) Dress uniformly with other line umpires as prescribed by the tournament and/or the ATP.
- 5) Sit erect with both feet on the ground with arms resting on his or her legs.
- 6) Concentrate on the assigned line; conversation with spectators or others is to be avoided.
- 7) Be accountable to the chair umpire only and have no discussions with the players. A player's questions must always be referred to the chair umpire. However, a line umpire may answer a reasonably precise question if it relates to a call, especially foot faults, unless that call has been overruled.
- 8) Move away from the on-court chair if necessary to get the best view possible of the assigned line.
- 9) Make all calls as quickly as possible, maintaining consistency and accuracy. On very close calls a fraction of a second's hesitation is recommended to make sure that the call is correct.
- 10) Never call a ball "Out" until it actually hits out or it hits a permanent fixture.
- 11) Make "Out," "Fault," "Net" and "Foot Fault" calls loudly and crisply followed by the appropriate hand signal. Foot faults are never called until the serve is struck.
- 12) Do not make a call for a "good" ball. However, whenever there is a close call on a good ball, the "good" ball hand signals should be given quickly to confirm the call.
- 13) When there is an erroneous call, immediately call "Correction" so that the chair umpire and the players are aware of the error. Then, make the corrected call.
- 14) Do not give an opinion on a call that is not his or her responsibility.
- 15) Remain silent if the chair umpire overrules a call. Direct player inquiries to the chair umpire.
- 16) If directed by the chair umpire to identify a mark, and the line umpire is sure of the location of the mark, the line umpire should walk directly to the mark and point to it in a manner that is clear to the chair umpire. The line umpire should then return to his position without comment.
- 17) Promptly yield to the chair umpire when unsighted on a call.
- 18) If the line umpire sees that he or she may hinder a player's stroke, make a rea-

## V. PERSONNEL

sonable effort to get out of the way, but in so doing, make as little movement as possible.

- 19) When there are Code Violations by players not witnessed by the chair umpire, inform the chair umpire immediately or as soon as is reasonable prior to the start of the next point, without disrupting a point or the match. The line umpire should quickly approach the chair umpire and report the facts of the violation.

### 5.08 Referee

#### A. Assignment and Designation Process

##### 1) ATP World Tour Tournaments

Each tournament is required to hire a referee approved by the ATP.

##### 2) ATP Challenger Tour Tournaments

Each tournament is required to hire a referee approved by the ATP, unless otherwise determined by the ATP.

#### B. Waiver of Obligation – Referee

A tournament may petition the ATP to waive the referee requirement. The following guidelines will be used to determine whether or not a waiver is appropriate for that particular event:

- 1) Must be an established event.
- 2) 32 draw.
- 3) 2-court event.
- 4) All matches played at one site, including qualifying.
- 5) Size of venue will be a consideration.
- 6) Must have the recommendation of the previous year's supervisor that a waiver, if approved, will not jeopardize the quality of service.
- 7) Must be able to provide a suitable assistant to the supervisor.

#### C. Fees and Expenses

##### ATP World Tour and ATP Challenger Tour Tournaments

Each tournament must provide each referee with single room hotel accommodations, meals and laundry. Complimentary rooms shall be in the player hotel or another hotel approved by the ATP or the supervisor.

Each tournament shall pay a fair and reasonable fee and travel expense to each designated and approved referee hired by the tournament.

#### D. General

The referee is hired by the tournament to advise in planning the event and shall assist the supervisor while being available to serve on the scheduling committee.

## V. PERSONNEL

### E. Responsibilities

Advise, assist and cooperate with the supervisor as appropriate and necessary when carrying out any assigned duties or responsibilities. Assigned duties may include;

- 1) Organizing the facilities, equipment and staff, to support play beginning with the qualifying competition.
- 2) Preparing the tentative schedule of play for the week and obtaining a listing of all tournament activities having an impact on the court schedule.
- 3) Confirming the conditions of play, (i.e.), make and number of tennis balls, types of beverages including electrolyte, how matches are to be called, etc.
- 4) Ensure that each court is equipped as follows:
  - a) Umpire's chair.
  - b) Line umpire chairs.
  - c) Player's chairs.
  - d) On-court beverages.
  - e) Measuring device.
  - f) Stopwatch, scorecard, etc. (ATP Challenger Tour and ATP World Tour qualifying).
- 5) Prepare the daily order of play, in coordination with the tour manager.
- 6) Sign-in Documents. The referee shall post all sign-in documents (singles qualifying, doubles, doubles alternates and lucky losers) in the referee's office with appropriate notices on the official bulletin board.
- 7) Designate a highly visible place in the general player's area as the "Official Bulletin Board" and notify all players of its designation and location.
- 8) The daily order of play shall be posted on the official bulletin board as soon as issued but not later than 10 p.m.
- 9) Designate a visible timepiece at a fixed location as the "Official Clock" of the tournament.
- 10) Designate a specific area from which matches shall be called in accordance with the order of play using all available and reasonable means.
- 11) Make appropriate arrangements for the safe escorting of players to and from the court before and after the match.
- 12) Be on-site at all times during the playing of matches in the tournament. The referee may not be a chair umpire or Chief of Umpires.

### 5.09 Chief of Umpires

#### A. Assignment and Designation Process

ATP World Tour and ATP Challenger Tour tournaments are required to hire a Chief of Umpires approved by the ATP, unless otherwise determined by the ATP.

#### B. Fees and Expenses

ATP World Tour and ATP Challenger Tour Tournaments

## V. PERSONNEL

Each tournament must provide each Chief of Umpires with single room hotel accommodations, meals and laundry. Complimentary rooms shall be in the player hotel or another hotel approved by the ATP or the supervisor.

Each tournament shall pay a fair and reasonable fee and travel expense to the Chief of Umpires hired by the tournament.

### C. General

The Chief of Umpires is approved by the ATP, hired by the tournament and is responsible for having sufficient quality line umpires assigned to each match.

### D. Responsibilities

- 1) Recruit a sufficient number of competent officials for the tournament. Be prepared to respond to or make recommendations to the Fulltime Official who is coordinating assignments and designations of all necessary and required chair umpires.
- 2) Conduct the necessary pre-tournament training of officials including review of all appropriate ATP Rules and Regulations.
- 3) Prepare a list of officials, which shall include the mailing address and national or local certifications, if any, of all officials used during the tournament. A copy of such list shall be delivered to the referee and to the supervisor.
- 4) Be on-site at all times during play. The Chief of Umpires may not be a chair or line umpire unless authorized by the supervisor.
- 5) Schedule the on-court assignments of line umpires for each day of the tournament, subject to the approval of the supervisor. Line umpires for the quarterfinals, semifinals and finals must have worked a minimum of two (2) days prior to the quarterfinals and have the supervisor's specific approval.

### 5.10 Ball Persons

Each ATP World Tour and ATP Challenger Tour tournament must provide ball persons for all main draw and qualifying competition matches. Ball persons should be on-site and available at a reasonable time prior to the first match of the day and there shall be ball persons available until the conclusion of play each day.

#### A. Number

Six (6) ball persons are recommended per court.

#### B. Clothing

Clothing provided by the tournament for ball persons shall not be solid white, yellow or other colors that may interfere with the vision of the players, unless otherwise approved by the ATP. It is recommended that dark-colored clothing be avoided for outdoor tournaments played in high temperatures. Clothing should not be identical to clothing provided to the line umpires.



## V. PERSONNEL

### 5.11 ATP/ITF/WTA Code for Officials

The ATP, ITF and WTA Tour require a high standard of professionalism from all certified officials and other officials working at ATP, ITF and WTA Tour events. These standards are as follows:

- 1) Officials must be in good physical condition.
- 2) Officials must have natural or corrected vision of 20-20 and normal hearing. In addition, international chair umpires must submit an eye test form each year to ITF Officiating and all certified officials must submit an eye test form every two years to ITF Officiating.
- 3) Officials must be on time for all matches assigned to them.
- 4) Officials must understand the Rules of Tennis, the Duties and Procedures for Officials and all ATP, ITF and WTA Tour Tournament Regulations and Codes of Conduct for events at which they are officiating.
- 5) Officials should maintain personal hygiene and should maintain a professional appearance at all times.
- 6) Officials must not drink any alcoholic drinks before any match on the day they are to officiate, or at any time on-site while play is in progress, or while in uniform. As a guideline, officials should not drink alcoholic drinks for 12 hours before officiating.
- 7) Officials must maintain complete impartiality with respect to all players at all times. An official must not officiate in any match in which he/she has a relationship with one of the players that might be considered a conflict of interest. The perception of a conflict shall render an official unsuitable for such an assignment.

Officials shall not socialize with or become intimate with players, or enter into any relationship or take any action that casts doubt on his/her impartiality as a tennis official. However, officials are not prohibited from staying in the same hotels as players nor from attending social functions at which players may be present.

Certified officials must register any potential conflict of interest with ITF Officiating. This includes when a certified official is a professional tennis player, National Tennis Coach, a National Tennis Team Captain, a close friend, relative or coach of a professional tennis player. They should also register the fact that they work for a company that has a commercial interest in tennis, or in a tournament director/organizer.

- 8) Officials must not criticize or attempt to explain calls or decisions by other officials to anyone other than to those officials directly, the supervisor/referee or the ATP, ITF and WTA Tour staff responsible for officiating. For the avoidance of doubt, officials are subject at all times to the relevant provisions and penalties set forth in the unified Professional Tennis Integrity Program.
- 9) Officials are bound by and must comply with all of the provisions of the Uniform Tennis Anti-Corruption Program, and it is their responsibility to acquaint themselves with all the rules, including the requirement to report any potentially corrupt approaches to the Tennis Integrity Unit ([confidential@tennisintegrityunit.com](mailto:confidential@tennisintegrityunit.com)). The Program can be found on: <http://officiating.atpworldtour.com>.

## V. PERSONNEL

- 10) Officials shall not have conversations with the crowd, except in the ordinary course of controlling the crowd during a match.
- 11) Officials must not participate in a media interview or meeting with a journalist where his/her statements relating to tennis officiating can be printed or broadcast without the approval of the supervisor/referee.
- 12) Officials must at all times conduct themselves in a professional and ethical manner, giving due regard to the supervisor/referee, players, officials, tournament personnel and public. International and White Badge Officials must also set a good example in their conduct to other officials.
- 13) Officials must make all tournament related requests to the supervisor/referee or chief umpire, rather than making requests directly to the tournament director or staff.
- 14) An official shall commit to each event he/she works until released by the supervisor/referee. If an official has accepted a tournament selection, he/she shall not withdraw from that tournament to officiate at another tournament at the same time, without the permission of the ATP, ITF or WTA Tour officiating representatives.
- 15) Violations of the Code for Officials must be reported by the supervisor/referee to the governing body of the tournament (ATP, ITF or WTA Tour). However, if a certified official commits such Violation, this must be reported immediately to the ATP, ITF and WTA Tour for the matter to be considered.

The supervisor/referee has the authority to release an official from a tournament for a violation of the Code for Officials, but where practical this decision should be taken together with the person responsible for officiating in the relevant organization (ATP, ITF or WTA Tour). A supervisor/referee may choose not to assign an official at a tournament until he/she has been able to contact the person responsible for officiating in the relevant organization.

An official who violates any of these required standards may have their certification withdrawn, or he/she may be suspended from officiating for a certain period, as decided by the ATP, ITF and WTA Tour officiating representatives.

Any official who is sanctioned as a result of a violation of the Code for Officials may appeal their sanction within 21 days to the Appeal Panel which is comprised of three (3) individuals representing each of the ITF, ATP and WTA.

## VI. FACILITIES & ON-SITE CONDITIONS

### 6.01 Courts

#### A. Court Surface

- 1) Outdoor court surfaces shall be classified as either a) hard; b) clay; or c) grass.
- 2) Indoor surfaces shall be Indoor Hard and shall be constructed using an acrylic or similar surface paint applied on a hard or semi-hard base.
- 3) Any court surface or change in a tournament's court surface must be approved by the ATP.
- 4) A change in a tournament's court surface will not be considered for approval without a written petition by the tournament.

#### B. Size, Position and Color of Courts

- 1) The Court shall conform to the specifications of the Rules of Tennis. The ATP reserves the right to restrict the color of an indoor synthetic court as well as outdoor surfaces. The lines of the court shall be white.
- 2) Courts shall be laid out with the long axis north and south; however, geographic considerations may modify this orientation in order to minimize the adverse effect of serving into the sun.
- 3) Courts shall not be less than 60 feet (18.29 m.) wide and 120 feet (36.58 m.) long. Stadium courts should be 66 feet (20.11 m.) x 132 feet (40.23 m.).

#### C. Preparation of Surface

Clay, composition and loose surface courts shall be swept and lines cleaned before the start of all matches and properly maintained.

#### D. Lighting

##### 1) Minimum Number of Lighted Courts – Outdoor events

- a) ATP World Tour Masters 1000. Stadium Court, two (2) other show courts plus one (1) practice court.
- b) ATP World Tour 500. Stadium Court plus one (1) other show court.
- c) ATP World Tour 250. No minimum requirement.

##### 2) Intensity

- a) **ATP World Tour Tournaments.** Lighting must be evenly distributed on the court with a minimum recommended intensity of 100 foot-candles (1076 LUX), averaged over 15 readings on court.  
The recommended minimum lighting for televised events broadcasting in high definition is an average of 285 foot candles (approximately 2,000 lux). The light should be distributed across the court evenly with a consistent color temperature.
- b) **ATP Challenger Tour Tournaments.** Lighting must be evenly distributed on the court with a minimum recommended intensity of 70 foot-candles (750 LUX), averaged over 15 readings on court.

- 3) **High/low ratio.** A ratio of the highest to lowest readings should be no greater than 1x2.0 but the recommended ratio is 1x1.5.

## VI. FACILITIES & ON-SITE CONDITIONS

- 4) **Light poles.** Light poles should be positioned so that they are evenly distributed around the court and it is recommended that light pole heights for other than show courts be no lower than forty (40) feet (12.19 m.) or no lower than other non-show court lights at the facility, e.g., if others are sixty (60) feet (18.29 m.), then new lights should be sixty (60) feet (18.29 m.) high.
- 5) The supervisor has the authority to suspend play on any court if the intensity of illumination, in his judgment, is insufficient for professional tennis.

### E. Back Fences, Back Walls, Banners, Signs and Seats

- 1) The back fences, back walls, net, net posts, line umpire boxes and other fixtures on a court shall not have any white, gray, yellow or other light colors that can interfere with the vision of the players as determined by the supervisor.
- 2) Background and lettering on rotating banners should be consistent with the color of the back walls. If placed in front of back walls, rotating banners can change only during a changeover. If placed in front of side walls, rotating banners can change only after the completion of any game.
- 3) Spectator seating shall not have any white, gray, yellow or other light colors that can interfere with the vision of the players. Light colored seats shall be covered to comply with this rule.

**F. Ceiling Height.** Indoor or covered show courts shall have a minimum top height of forty (40) feet (12.19 m.) except as otherwise approved by the ATP.

### 6.02 Match and Practice Courts

**A.** Each tournament must provide match and practice courts as follows:

ATP World Tour Masters 1000 (Combined)	8 match courts 8 practice courts (on site)
ATP World Tour Masters 1000 (Outdoors)	5 match courts 4 practice courts (on site)
ATP World Tour Masters 1000 (Indoors)	3 match courts 4 practice courts (minimum 1 on-site)
ATP World Tour 500 (Outdoors)	5 match courts 4 practice courts (minimum 3 on-site)
ATP World Tour 500 (Indoors)	2 match courts 4 practice courts (minimum 1 on-site)
ATP World Tour 250 (Outdoors)	3 match courts 1 practice court for every 16 players in singles draw, minimum of 2.
ATP World Tour 250 (Indoors)	2 match courts 1 practice court for every 16 players in singles draw, minimum of 2.

## VI. FACILITIES & ON-SITE CONDITIONS

ATP Challenger Tour (Outdoors)	3 match courts 1 practice court for every 16 players in singles draw, minimum of 2.
ATP Challenger Tour (Indoors)	2 match courts 1 practice court for every 16 players in singles draw, minimum of 2.

**B.** All match and practice courts must be the same surface, speed and conditions as the main draw and must be available for practice from 9:00 A.M. on Friday prior to the start of the tournament until the conclusion of the tournament.

**C.** Courts must be set up to provide normal support, including drinks (water), sawdust and towels.

### 6.03 Balls

Tennis balls used at ATP World Tour and ATP Challenger Tour tournaments must be approved by the ATP a minimum of ninety (90) days prior to the start of the tournament.

**A. Changes and Number.** Ball changes and the number of balls used per match shall be the same for all main draw matches throughout the tournament unless authorized by the supervisor. Balls should be opened just prior to the match or ball change. In case of a suspended or postponed match, the match balls shall not be used in the warm-up, they shall only be used when play resumes. Each ATP World Tour tournament must provide approved tennis balls in accordance to the following:

- 1) **ATP World Tour Tournaments:** Six (6) balls for each main draw and qualifying match to be changed after seven (7) and nine (9) games throughout the tournament.
- 2) **ATP Challenger Tour Tournaments:** At least four (4) balls are to be provided for each main draw and qualifying match to be changed at least every seven (7) and nine (9) games as determined by the tournament.

**B. Lost Balls.** Play must be continuous even if a ball needs to be replaced.

- 1) **ATP World Tour Tournaments:** If a ball is lost or becomes unplayable, then another shall be added as soon as it is reasonably possible. During the warm-up or within two (2) games (before first point is begun in the third game or if the first point has to be replayed for any reason) after a change of ball, a new ball shall be used as a replacement; otherwise a ball of like wear shall be supplied.
- 2) **ATP Challenger Tour Tournaments:** If a ball is lost or becomes unplayable and there are less than three (3) balls remaining, then another ball must be added immediately for use in play. During the warm-up or within two (2) games (before first point is begun in the third game or if the first point has to be replayed for any reason) after a change of balls, a new ball shall be used as a replacement; otherwise a ball of like wear shall be supplied.

**C. Practice Balls**

- 1) **ATP World Tour Tournaments:** Each main draw player is entitled to six (6) new

## VI. FACILITIES & ON-SITE CONDITIONS

balls per day for practice, free of charge, one (1) day prior to the start of qualifying until that player is eliminated. Once eliminated, he shall be entitled to three (3) new balls per day for practice. Players must return practice balls.

- 2) **ATP/Challenger Qualifying Competition:** Players listed in the South African Airways ATP Rankings (singles) or ATP Doubles Rankings who are practicing for qualifying competition are entitled to three (3) new balls for practice, free of charge, one (1) day prior to the start of the qualifying competition until that player is eliminated. Players must return practice balls.
- 3) **ATP Challenger Tour Tournaments:** Each main draw player is entitled to three (3) new balls per day for practice, free of charge, one (1) day prior to the start of qualifying until that player is eliminated. Once eliminated, he shall be entitled to three (3) used balls per day for practice. Players must return practice balls.

### **Ball Change Error**

**Case:** A player serves a first service fault. He starts to serve the second serve and the chair umpire realizes that there should be new balls in play.

**Decision:** The chair umpire should wait to change balls until that player or team is scheduled to serve (Rules of Tennis, rule 37), unless a let is called resulting in the first point being replayed.

### **New Balls to Wrong Player(s)**

**Case:** The wrong player or team was given new balls with which to serve.

**Decision:** If the error is discovered after the first point, then the team/player continues to serve with the new balls. The team/player who should serve with new balls receives new balls to serve the next game. Once a point has been played in the second game, the ball change sequence shall remain as altered. In no case shall new balls be replaced by the old balls after a service game has started.

### **Re-Warm-Up, Balls**

**Case:** At the end of a game there is a twenty (20) minute rain delay. A ball change was also to occur after that game. When play is resumed, new balls will be in play. What balls are used for the re-warm-up?

**Decision:** New balls should be used for the re-warm-up. At the end of the warm-up, these balls will be taken away and replaced with new balls to resume the match.

### **Broken Ball**

**Case:** A ball in play breaks (no compression).

**Decision:** Replay the point.

### **Soft Ball**

**Case:** After the point has been completed, the player claims that the point should be replayed because the ball is soft and unplayable.

**Decision:** The point stands as played. A "soft" ball is not cause for replaying a point even if the chair umpire decides that the ball must be replaced.

**Case:** During a rally, player A catches the ball and wants the point re-played, claiming that the ball is "soft" and unfit for play.

## VI. FACILITIES & ON-SITE CONDITIONS

**Decision:** Player A loses the point. A "soft" ball is not cause for replaying a point. The ball, however, may be taken out of play.

### 6.04 Crowd Movement / Spectator Seating

#### A. Regulation

Each ATP World Tour tournament shall allow spectators seated above the lowest tier of seats that surround the playing area of the courts to move to and from their seats at any time during play.

- 1) The tournament director and the supervisor will make the designation of the lowest tier at each tournament.
- 2) In cases where there is no clear break in the seating configuration, the tournament director and the supervisor shall determine the most logical designation.

### 6.05 Security at Tournaments

A. Each tournament has the responsibility to provide adequate security at the tournament site. Players have the responsibility to report any threat or unusual occurrence to the tournament director, supervisor or Executive Vice President - Rules & Competition when at a tournament.

B. The continual use of laptop computers or other handheld electronic devices within the confines (spectator area) of the tournament match courts shall be prohibited and each tournament shall take reasonable steps to enforce such prohibition. The exception to this provision is properly credentialed media, tournament vendors and tournament staff when used in the performance of their duties.

### 6.06 Equipment & Supplies

#### A. Placement /Approval

The supervisor must approve the placement of items or equipment on any court. The supervisor may remove or have removed any item (including advertising) that may affect the safety of a player, official or ballperson.

#### B. Chairs

##### 1) Chair Umpire

- a) The sitting platform of the chair for the chair umpire must be between six (6) feet (1.83 m.) and eight (8) feet (2.44 m.) high. The seating area should be approximately two (2) feet (.61 m.) wide. The chair shall be centered along the extension of the net approximately three (3) feet (.914 m.) from the net post if the court configuration will accommodate such placement.
- b) The chair umpire's and on-court announcer's, if any, microphone must have an "on-off" switch.
- c) Umbrellas are required if the sun is a factor.
- d) At all outdoor events, the positioning of the umpire's chair shall be on the West side of the court on all courts except for competition court that had the umpire's chair on the East side of the court in 2000 due to infrastructure or other agreed unusual requirements.

## VI. FACILITIES & ON-SITE CONDITIONS

### 2) Line Umpire

- a) Each tournament shall provide chairs for service and base line umpires located on an extension of their respective lines along the side fence not closer than twelve (12) feet (3.66 m.) from the doubles sideline. Chairs for sideline and center service line umpires should be located next to the back of the court at least twenty-one (21) feet (6.40 m.) behind the baseline. Service and baseline umpire chairs should not be elevated above the surface of the court. The seating area must be a minimum of two (2) feet (.61 m.)
- b) In outdoor events whenever the sun is a factor, line umpire chairs shall be positioned so that line umpires are not facing the sun unless otherwise approved by the ATP. When the sun is not a factor, the chairs should be positioned on the opposite side of the court from the chair umpire.

### 3) Net Judge

- a) A sponsorship box, which surrounds the net judge chair, may not extend past the net post into the court.
- b) An approved electronic net device can replace the net judge.

### 4) Player

- a) Each tournament shall provide chairs for the players located on each side of the chair umpire. As a guide, the front portion of the player chair/bench should be no closer to the court than the back support/leg of the umpire's chair.
- b) Umbrellas are required if the sun is a factor.

### C. Measuring Devices

Each tournament shall provide a measuring stick, tape measure or other measuring device for the measuring of the net height and location of the singles sticks.

### D. Net

- 1) The net band shall be cloth, canvas or vinyl, and the net shall extend to the ground, unless otherwise approved by the on-site supervisor.
- 2) Each tournament shall have spare nets available.
- 3) There can be no commercial or manufacturer identification on the net except as approved by the ATP.

**E. Net Posts and Net Post Signage.** The net posts shall conform to the specifications in the Rules of Tennis, unless otherwise approved by the ATP. No signage of any type may be placed on the net posts or net except as determined solely by the ATP.

**F. Sawdust.** Each tournament shall provide sawdust for players on match and practice courts.

**G. Scoreboards.** Each tournament must provide scoreboards for all courts to be placed at the corner or side of the courts. Placement and color of scoreboards shall not interfere with a player's vision.

**H. Towels.** Each tournament shall provide towels for players on match and practice courts and in the players' locker room. Towels should be pre-washed and of sufficient size for the intended use.

## VI. FACILITIES & ON-SITE CONDITIONS

### I. Beverages

- 1) **Players.** Each tournament shall provide, in sealed containers, electrolyte replacement drinks, non-carbonated bottled water and other beverages for players on-court, in the players' lounge and on the practice courts.
- 2) **Officials.** Each tournament shall provide water and other beverages for Officials on match courts and in the official's off-court area.

### 6.07 Temperature and Ventilation For Indoor Facilities

Indoor facilities must provide normal and standard heating, cooling and ventilation. The supervisor may suspend play if, in his judgment, the conditions of play are unacceptable for professional tennis.

### 6.08 Offices

Each tournament shall provide suitable workspace/office for ATP staff and officials.

### 6.09 Communication Devices

Each tournament must provide communication devices to the referee, Chief of Umpires, and physiotherapist(s) except if otherwise approved by the ATP. In addition, the following equipment is required to be on-site:

#### A. Phones

At a minimum, telephones with local access only are to be provided for the following ATP staff offices: ATP supervisor, ATP tour manager, ATP PR & Marketing manager and the ATP physiotherapist.

#### B. Copy machine

A copy machine should be provided in, or near, the supervisor's office. Copy machine should be available on the morning prior to the start of the qualifying competition.

#### C. Printer

A printer shall be provided in the office of the Supervisor. Printer should be available on the morning prior to the start of the qualifying competition and be available through the last match of the tournament.

#### D. Fax Machine

A fax machine is to be provided in the PR & Marketing office.

#### E. Internet

Always-on high speed Internet connection is to be provided in the offices of the ATP supervisor, ATP tour manager, ATP physiotherapist and the ATP PR & Marketing unless otherwise approved by the ATP. The recommended speed is 1 mbs or greater and the minimum acceptable speed is 512 kbs. Recommended user access is via Ethernet or WiFi.

## VI. FACILITIES & ON-SITE CONDITIONS

Unless reasonably unable to do so, tournaments shall use web filtering technology to restrict access to internet gambling sites in all areas where tournament provided internet access is provided.

### F. Live Scoring

Each Tournament shall be responsible for the set up and maintenance of an encrypted wireless internet network (WiFi) with a signal throughout the venue, based on specifications provided by ATP, to support live scoring services for each match\* of the event and subject to 6.09 F, will provide ATP access to such signal and assist ATP in its efforts to produce and host the live score data generated from each match. Each tournament hereby consents to ATP's non-exclusive use of such live score data, however, each Tournament shall not allow or authorize the dissemination, transmission, publication or release from the grounds of the Tournament of any live match score or related statistical data, including without limitation the live score data from the WiFi network, by a third party until :30 seconds after the actual occurrence of the incident of match play or action that leads to such live score update (e.g., a point being scored), such delay shall not be applicable to the live audio and/or visual broadcast or streaming by any method or means (i.e., moving pictures and/or sound/ audio reporting of the actual on-court action) and purposes related to such broadcast, of any match (subject to Exhibit C – Broadcast Standards set forth herein). Further, each Tournament shall notify ATP in advance of any third party to whom the Tournament has granted access to the WiFi network for the purpose of accessing the live score data.

\*Tournaments using an alternate venue for main draw matches due to weather or other unforeseen circumstances are encouraged but not required to provide services to support live scoring. Tournaments are not required to provide live scoring support for qualifying matches played at an alternate venue.

### 6.10 Tour Identification Card

The 2012 Tour Identification Card (TIC) shall be honored at all ATP World Tour and ATP Challenger Tour events and will permit the holder entry to the tournament office in order to receive the appropriate tournament credential. Players must be accepted into the event to be eligible for a credential; Player Support Team members must be in the company of a player who is accepted into the event; ATP staff members must be working the event or have otherwise applied for and been accepted for a credential. All others must have applied in advance and approved for a credential by the tournament.

### 6.11 Tournament Credentialing and Ticketing

**A. General.** Tournaments must use a photo credentialing system.

**B. Proof of Identity.** Tournaments must require proof of identity for all persons prior to issuing credentials; this must be through photo identification such as passport or driver's license.

**C. Personal information.** All persons applying for credentials as part of a Player Support Team, including guests, must complete an on-site form, acknowledging and agreeing to the conditions of the Uniform Tennis Anti-Corruption Program rules and

## VI. FACILITIES & ON-SITE CONDITIONS

the Tennis Anti-Doping Program. Tournaments must include and take reasonable steps to enforce the following policy on all non-media persons issued credentials: No credentialed person may continually collect, disseminate, transmit, publish or release from the grounds of the Tournament any match scores or related statistical data during match play (from the commencement of a match through its conclusion for any commercial, betting or gambling purpose). Such policy shall be printed on all Tournament credentials or otherwise notified to credentialed persons.

**D. Ticketing.** Tournaments must include and take reasonable steps to enforce the following policy on all ticket holders: no ticket holder may continually collect, disseminate, transmit, publish or release from the grounds of the Tournament any match scores or related statistical data during match play (from the commencement of a match through its conclusion for any commercial, betting or gambling purpose). Such policy shall be printed on all Tournament tickets or otherwise notified to ticket holders prior to purchase.

### 6.12 Player Benefits - Guest Passes/Credentials

A player entered in ATP World Tour and ATP Challenger Tour tournaments shall be issued a reasonable number (a minimum of two) guest passes/credentials for his use while competing in the event. Guest passes / credentials shall be issued only after the player guest has provided proof of identity (photo I.D.) and has completed and signed the player guest form. These guest passes/credentials include access to the site, seating in designated areas and other benefits as determined by individual tournaments and shall be valid as long as the player remains at the tournament. Player guest passes/credentials shall not allow access to the player locker room or the physiotherapist room. All other access is at the sole discretion of the tournament. Passes/credentials can be revoked at any time based on recommendation of the supervisor to the tournament director.

Credentials provided to the player may not be exchanged, directly or indirectly, for money, benefit or anything of value. Violation of this section shall subject the player to the penalties set forth under the Player Major Offense – Aggravated Behavior.

Receipt by any person of guest passes/credentials or any other benefits or special accommodations are expressly subject to the "Limits to On-Site Access" set forth in the Rulebook.

### 6.13 Player Lounge

ATP World Tour and ATP Challenger Tour tournaments shall provide a suitable space appropriately equipped for the players, their support team and their properly credentialed guests. The player lounge should be secure with only persons with proper access allowed to enter.

Unless reasonably unable to do so, tournaments shall use web filtering technology to restrict access to internet gambling sites in all areas where tournament provided internet access is provided.

Receipt by any person of guest passes/credentials or any other benefits or special accommodations are expressly subject to the "Limits to On-Site Access" set forth in the Rulebook.

## VI. FACILITIES & ON-SITE CONDITIONS

### 6.14 Locker Room

**A. General.** Each tournament shall provide players with a suitably equipped and secure locker room. The entrance to the locker room shall be monitored and only properly credentialed persons shall be allowed to enter. Only those persons with access approval and properly credentialed tournament staff, who in the performance of their duties justify access to the locker room, shall be authorized to enter the locker room.

#### B. Lockers

- a) A lockable locker must be available for use by each player.
- b) If the locker requires a separate lock, then this must be provided to each player upon arrival.
- c) If the lockers do not have the ability to be locked; or cannot be locked in a manner that provides reasonable safety, then:
  - i) The tournament must provide separate lock boxes where a player may secure his valuables; or
  - ii) Another method whereas a player may secure his valuables with reasonable expectations of safety.

### 6.15 Stringing Service

**A. General.** A stringing service of a professional standard must be made available to the players throughout the length of the event.

#### B. Days / Hours of Service.

- 1) At a minimum, stringing service must be available beginning the day prior to the start of the qualifying competition and continue through the last day of the competition, including any carry-over days due to weather or other unavoidable circumstances.
- 2) At a minimum, must be on-site two (2) hours prior to the starting time for the first scheduled match of the day. Must be available continually throughout the day and until the completion of play for that day.
- 3) If play is scheduled at an approved alternate site, then access to the stringing service must be provided at such alternate site from the start of play until play has been completed at that site.

#### C. Fees.

- 1) **ATP World Tour Events.** A reasonable fee per racquet may be charged and is the responsibility of the stringing service to collect from the player.
- 2) **ATP Challenger Tour Events.** The recommended maximum fee per racquet is \$12 USD / €12 and is the responsibility of the stringing service to collect from the player.

### 6.16 Food

Each tournament must provide, either complimentary or at a cost, food for the competitors. Food service should begin no later than the first day of qualifying and continue until the completion of the tournament.

See Exhibit T for Player Food Service Guidelines

## VI. FACILITIES & ON-SITE CONDITIONS

#### A. Hours of Service.

- 1) At a minimum, from one (1) hour prior to the start of play through completion of the day session.
- 2) If the tournament also has a night session, then food should be available to those players playing in the night session up until the last match has gone on court.

#### B. Safety

- 1) All water and electrolyte drinks must be served in unopened sealed containers.
- 2) All food and beverages must be properly stored and maintained at an appropriate temperature, which complies with local health regulations.

### 6.17 On-Site Access / Limits to On-Site Access

The President, or his designee, may, in his sole discretion, instruct any ATP World Tour or ATP Challenger Tour tournament to prohibit any person from obtaining access to any areas at a tournament site that are not generally open or available to all members of the public or from utilizing tournament transportation. The President, or his designee may so act for any reason, including without limitation, any concern that the President, or his designee may have, in his sole discretion, that such person may pose any issue with respect to security, reputation, integrity, misconduct, or competition.

### 6.18 Transportation

Each tournament must provide scheduled transportation for players, officials and ATP staff that ensures players arrive on-site at least "on the hour". The above requirement applies to players both in the main draw and qualifying.

### 6.19 Player Treatment Room

Each tournament must provide a treatment room for players and physiotherapists centrally located to the courts and the locker room. If the treatment room is located in an area separate from the locker room, proper security at the entry point must be provided. Only those persons with access approval through the TIC and properly credentialed tournament staff, who in the performance of their duties justify access to the locker room, shall be authorized to enter the player treatment room.. The room must be private and equipped with ice and ice chests/coolers, towels, electricity and treatment/massage tables in the following numbers: 2 per 32 singles main draw and additional tables for larger draws. See Exhibit U for full medical facility guidelines.

### 6.20 First Aid

Each tournament must provide a First Aid Team present at all times on the tournament site for public emergencies.

### 6.21 Anti-Doping Facilities and On-Site Personnel Assistance

#### A. On-Site Testing Facility

- 1) Each ATP World Tour and ATP Challenger Tour tournament, when requested, is obligated to provide at its own cost the following facilities:

## VI. FACILITIES & ON-SITE CONDITIONS

- a) A lockable private room with bathroom and an adjacent waiting room; or, at the discretion of the Anti-Doping Personnel,
  - b) An alternative on-site location with a suitable trailer.
- 2) In addition, the tournament is required to provide at its own cost appropriate furniture, water, fruit and television or court monitoring systems for the testing facility as well as staff assistance for site set-up and facility maintenance during the tournament and a telephone line.

### B. Volunteer Observers Provided by Tournament.

Each tournament must provide at its own cost male staff members and/or volunteers who can assist the Official Anti-Doping Personnel and supervisor with the observation of players selected for testing. The Official Anti-Doping Personnel shall notify a tournament of the number of personnel required no later than three (3) weeks prior to the start of an event.

See Exhibit Z for full Anti-Doping Facilities Guidelines.

### 6.22 Media Facilities Guidelines

All ATP World Tour tournaments and the Barclays ATP World Tour Finals should provide adequate media facilities. All media areas shall be gambling free zones and any and all persons credentialed for this area, if found to be gambling on tennis or passing insider information to third parties for use in connection with gambling, shall have their credentials revoked. Media credentials must contain a provision whereby the media member acknowledges and agrees that, except as allowed pursuant to Rule 6.09 F., he/she will not disseminate, transmit, publish or release from the grounds of the Tournament any live match score or related live statistical data until :30 seconds after the actual occurrence of the incident of match play or action that leads to such live score update (e.g., a point being scored), and that such use shall be solely for news reporting and editorial use.

Unless reasonably unable to do so, tournaments shall use web filtering technology to restrict access to internet gambling sites in all areas where tournament provided internet access is provided.

See Exhibit V for full Media Facilities Guidelines.

### 6.23 Electronic Line Calling Facilities Guidelines

The use of an approved electronic system for reviewing line calls and/or overrules is authorized for use at ATP events.

See Exhibit W and X for full Electronic Line Calling Facilities Guidelines and Protocol.

## VII. THE COMPETITION

### 7.01 ATP Fees

#### A. Entry Fees

- 1) **ATP World Tour Tournaments.** There are no entry fees.
- 2) **ATP Challenger Tour Tournaments.** At the option of the tournament, each player accepted into the main draw (singles or doubles) shall pay an entry fee of 20.00 (USD/EURO). At the option of the tournament, each qualifier (singles or doubles) shall pay an entry fee of 10.00 (USD/EUR). If a qualifier gains entry to the main draw, then any qualifying entry fee paid shall be applied to the main draw fee.

#### B. Service Fee

- 1) Players who are accepted into the main draw (singles or doubles) of an ATP World Tour Masters 1000 or ATP World Tour 500/250 tournament or the singles qualifying of an ATP World Tour Masters 1000 or ATP World Tour 500 tournament and are not members in good standing with the ATP must pay the following service fee to the ATP:

ATP World Tour Masters 1000:	Main Draw \$400/€400 event	Qualifying \$100/€100
ATP World Tour 500	Main Draw \$300/€300 event	Qualifying \$100/€100
ATP World Tour 250	Main Draw \$200/€200 event	

- 2) The tour manager will identify players who must pay a service fee that will be withheld from on-site prize money. Players who by virtue of their ranking position are not eligible for an ATP player membership may use these payments as a credit toward future membership fees. Service fees paid to the ATP may only be applied against membership dues in the calendar year in which they were paid.

#### C. Membership Fees

Membership fees are defined in the ATP By-Laws.

### 7.02 Entries

#### A. Gender / Age Limitation

The ATP will use the age of a player on the first (1st) day of the qualifying competition. Male players age sixteen (16) or older are not limited in the number of tournaments they may enter. Players under the age of sixteen (16) are subject to the following entry restrictions in ATP World Tour or ATP Challenger Tour tournaments (includes entry as a wildcard):

- 1) Male players under the age of fourteen (14) shall not be eligible for entry into any ATP World Tour or ATP Challenger Tour tournament.
- 2) Male players aged fourteen (14) shall be eligible for entry into a maximum of eight (8) ATP World Tour or ATP Challenger Tour tournaments.
- 3) Male players aged fifteen (15) shall be eligible for entry into a maximum of twelve (12) ATP World Tour and ATP Challenger Tour tournaments.



## VII. THE COMPETITION

### 7.03 Entry Deadlines

#### A. Main Draw/Qualifying Singles

The deadline for entries and withdrawals for the singles main draw is as follows:

- 1) **ATP World Tour Tournaments.** Forty-two (42) days prior to the Monday of the tournament Week (or the first tournament week in the case of tournaments scheduled for more than one (1) week). A player on the alternate list for the singles main draw may withdraw at any time prior to such time that he is moved into the main draw as a direct acceptance because of withdrawals of other players.

**NOTE:** The deadline for the ATP World Tour Masters 1000 - Monte Carlo main draw is twenty-eight (28) days prior to the Monday of the tournament week.

- 2) **ATP World Tour Masters 1000 and ATP World Tour 500 Qualifying.** Twenty-one (21) days prior to the first Monday of the tournament week. A player directly accepted into the qualifying competition may withdraw, without penalty, if he is moved into the main draw of an ATP World Tour 250 or ATP World Tour 500 tournament, or if he is still competing in an ATP World Tour, ATP Challenger Tour, or Futures tournament on the day prior to the commencement of qualifying. If a player is still competing past the sign-in deadline (9:00 p.m. local time), he will be withdrawn from the qualifying without penalty and will be allowed to accept a wild card into any ATP World Tour 250, ATP World Tour 500, ATP Challenger Tour or Futures tournament, including qualifying. If a withdrawal occurs prior to 12 noon, Eastern Time, USA, on Friday, the qualifying vacancy shall be filled by the next player on the qualifying alternate list. This player is not required to sign in. If a withdrawal occurs after 12 noon, Eastern Time, USA, on Friday, the qualifying vacancy will be filled from the on-site sign-in list, using the most recent South African Airways ATP Rankings (singles) list. Main draw vacancies will be filled from the main draw alternate list, not the qualifying acceptance list.

**NOTE:** For the Asian 500 and 1000 tournaments only, if a withdrawal occurs prior to 12 noon, Eastern Time, USA, the qualifying vacancy shall be filled by the next player on the qualifying alternate list regardless of when the qualifying draw is finalized.

*Case: May a player who is a direct acceptance to an ATP World Tour 500 qualifying event be withdrawn to move into the main draw of an ATP World Tour 250 event which is held in the same week?*

**Decision:** Yes.

- 3) **ATP Challenger Tour Tournaments.** Twenty-one (21) days prior to the Monday of the tournament week. A player on the alternate list for the singles main draw may withdraw at any time prior to such time that he is moved into the main draw as a direct acceptance because of withdrawals of other players. If a withdrawal occurs after 12 noon, Eastern Time, USA, on Friday, the vacancy will be filled by the highest ranked player from that event's qualifying sign-in list and players from the original alternate list who have contacted the on-site Supervisor prior to the qualifying sign-in deadline and preserved their eligibility on the new alternate list. A player can only preserve his eligibility on one list. Players who have signed in for qualifying are not eligible to preserve their position on any other alternate list. The most recent South African Airways ATP Rankings (singles) list shall be used for determining the order of this new alternate list.

## VII. THE COMPETITION

**NOTE:** In order to preserve his eligibility on the new alternate list, the player must phone the Supervisor directly and personally inform the supervisor that he wishes to preserve his eligibility as an alternate and the player must leave a contact number.

- 4) If a tournament date, site or surface is changed; it is the player's responsibility to withdraw from the event on or before the new entry/withdrawal deadline if he does not wish to play.

- 5) **Late Entries.**

Any player who submits an entry after the deadline may only be accepted into the singles main draw as a wild card, qualifier, or as a special exempt (if eligible).

- 6) **Emergency Situations.**

- a) The President may authorize substitutions in ATP World Tour tournaments in situations when there are withdrawal(s) of player(s) who would have been seeded based upon their position on the original acceptance list. The withdrawal and substitution must occur within the period beginning on the Monday prior to the start of the event week and ending at 12 Noon, Eastern Time, USA, on the Friday before the event week. The substitute(s) ranking, as of the entry deadline, must be within the original cut-off for the main draw. If no substitution is made within this defined time period, then the next player on the acceptance list shall be moved into the main draw.
- b) The tournament shall pay prize money equal to that paid first-round losers to each player who would have been a direct acceptance if not for the late substitution. This payment shall not apply in the case where the player gained entry into a main draw singles, at any event, by other means.

#### B. Main Draw Doubles

- 1) **ATP World Tour Tournaments**

- a) **Advance Entry.** Fourteen (14) days prior to the Monday of the tournament week (or the first tournament week in the case of tournaments scheduled for more than one (1) week). A team on the alternate list for the doubles main draw may withdraw at any time prior to such time that they are moved into the main draw as a direct acceptance because of withdrawals of other teams.
- b) **On-site Entry.** The on-site entry/withdrawal deadline for doubles is 2:00 PM Saturday local time prior to the first day of the tournament unless otherwise authorized by the ATP. The number of places available through the on-site entry is specified in the Composition of Draws (7.08.B) plus any spots made available through withdrawals occurring after 12 Noon Eastern Time, USA, on the Friday before the event week.

- 2) **ATP Challenger Tour Tournaments**

The entry/withdrawal deadline for doubles shall be 12 Noon Sunday local time prior to the first day of the tournament unless otherwise authorized by the ATP.

- 3) The doubles sign-in record shall be posted at a reasonable time prior to the sign-in deadline.

#### C. Entry Deadline Extensions

The ATP may extend the deadline for entries and/or withdrawals when unforeseen circumstances arise.

## VII. THE COMPETITION

### 7.04 Entry/Withdrawal Method

A player may enter a Grand Slam, ATP World Tour or ATP Challenger Tour tournament through a written entry form or other alternatives available to ATP player members.

#### A. Main Draw - Singles

1) No player shall be considered entered or withdrawn from an \*ATP World Tour Masters 1000, ATP World Tour 500\*\*, ATP World Tour 250 or ATP Challenger Tour tournament unless his written entry or written withdrawal is received on or before the entry or withdrawal deadline by a player relations staff member, ATP supervisor or through the PlayerZone. A player must have entered in order to be moved into the main draw as a direct acceptance because of the withdrawals of other players. For each ATP World Tour Masters 1000 tournament, players with South African Airways ATP Rankings (singles) positions equal or better than the number of direct acceptances, shall be automatically entered by the ATP. All other players must submit an entry to be considered for a direct acceptance due to withdrawals.

2) Once a player enters he is subject to all the withdrawal provisions.

3) Withdrawals, retirements or defaults during an ATP World Tour or ATP Challenger Tour tournament must be made through the supervisor.

\* For the mandatory ATP World Tour Masters 1000 tournaments, this section is applicable for withdrawals only as entries are automatic.

\*\* Commitment players are automatically accepted into the main draw of all ATP World Tour 500 events in which they have entered in a proper manner.

#### B. Main Draw - Doubles

##### 1) Advance Entry – ATP World Tour Only

a) No team shall be considered entered or withdrawn from an ATP World Tour tournament unless their written entry or written withdrawal is received on or before the entry or withdrawal deadline by a player relations staff member or ATP supervisor. A team must have entered in order to be moved into the main draw as a direct acceptance because of the withdrawals of other players.

b) Once a team enters they are subject to all the withdrawal provisions.

##### 2) On-Site Entry ATP World Tour and ATP Challenger Tour Tournaments

a) No team shall be accepted for on-site entry into the doubles event unless one player of the team personally signs the on-site entry list unless subsection d) applies.

b) If neither player of the team is able to sign the list because he is competing in the previous week's tournament or neither is qualified for or entered in the main singles draw, then such team may enter the doubles event by submitting a written entry to the ATP or by personally contacting the tour manager or supervisor at the tournament he wants to play.

c) Written entries submitted by a player(s) who is not on-site and who has not been able to talk to the tour manager or supervisor, must be received by the on-site supervisor prior to the deadline.

d) The tour manager or supervisor may sign-in and enter doubles teams.

## VII. THE COMPETITION

### Emailed Doubles Entry

**Case:** The supervisor/referee is sent a doubles entry via email. The email was not seen by the supervisor/referee until after the entry deadline. The date/time of the email show that it was received prior to the deadline. Is this a valid entry?

**Decision:** No. To be considered as a valid entry the official at the site of the doubles event (supervisor, referee or tour manager) must have actually viewed the email. The same decision would be made on undelivered faxes or an entry left on voice mail.

**Note:** Proper procedure for any emailed or faxed entries would be to ask for a confirmation from the person who the entry was sent. Barring confirmation, you should make personal contact prior to the entry deadline.

### C. Qualifying

Players may be entered in the main draw (singles or doubles) as qualifiers based on their success in the respective qualifying competition.

1) **Location.** Sign-in shall be either at the site of the qualifying competition or, if approved by the ATP and announced prior to the entry deadline, at the official tournament hotel.

2) **Sign-in.** To be eligible for the qualifying competition, a player must sign in with the supervisor and/or referee. The supervisor and/or referee may sign in a player prior to the qualifying competition sign-in deadline if such player has competed and lost in a Grand Slam, ATP World Tour or ATP Challenger Tour, or Futures tournament, on Wednesday (if the tournament is on a different continent than the following week's tournament), on Thursday or Friday by 9 p.m. (local time). This player must be able to be on-site and play his first round match by the end of the first round of qualifying. The player is responsible for having his entry confirmed by the supervisors at both tournaments.

Direct acceptances to ATP World Tour Masters 1000 and ATP World Tour 500 qualifying are not required to sign-in.

#### Sunday Start for Qualifying

**Case:** The qualifying event begins on Sunday, how does this affect players being signed in coming from the previous week's event?

**Decision:** The criteria for signing players in from other events is adjusted by one day, i.e. a player losing on Wednesday on a different continent is not eligible to be signed in when the next event's qualifying begins on Sunday.

3) **Time.** Sign-in shall be from not before 7 p.m., up to 9 p.m. local time on the night prior to the start of the qualifying competition (Friday night for a qualifying commencing on Saturday).

#### Can I Play Both?

**Case:** A player is playing a doubles match on Friday night that will not finish before the 9 p.m. singles qualifying deadline for the following week's tournament. The next tournament is 2-3 hours traveling time and because the doubles semifinals is scheduled for Saturday

## VII. THE COMPETITION

night, it is feasible for the player to drive between the two locations so that he could compete in the qualifying singles and still play the doubles semifinal should he win on Friday night. Can he be signed in for the singles qualifying?

**Decision:** Yes. The Saturday night doubles match (which cannot be a result of special scheduling) makes this possible for the player. Appropriate penalties apply if the player does not appear for his qualifying match or his doubles semi-final match, if he wins Friday night.

### **Players Miss Sign-In**

**Case:** Players cannot be at the qualifying sign-in on time because of circumstances beyond their control. If the supervisor is satisfied that the players were not at fault, may he sign them in?

**Decision:** No. However, the tournament does have the option of giving wild cards to such player(s).

### **Sign Me In**

**Case:** A player loses a match after 9 p.m. on Friday night but before the following weeks qualifying draw has been made. May he be signed in to the qualifying?

**Decision:** No. He may, however, be offered and accept a wild card into the qualifying.

### **Too Many Players Sign-In**

**Case:** The tournament director wants to increase the size of the qualifying to accommodate all of the players who have appeared on-site for the qualifying sign-in. Can he do this?

**Decision:** No. The size of the qualifying draw may not be increased.

## 7.05 Withdrawal/Late Withdrawal Penalties

The following shall result when a player withdraws after the deadline from the singles main draw of an ATP World Tour or ATP Challenger Tour tournament:

- A. A player shall be subject to the sanctions provided in the player Code of Conduct.
- B. If the withdrawal is from the singles main draw of an ATP World Tour tournament, the player shall be required to fulfill his obligations under the ATP Stars Program.
- C. If the withdrawal occurs after 12 noon, Eastern Time, USA, on Friday before the tournament week or, in the case of doubles, after the entry deadline, then the withdrawal shall be considered a late withdrawal and shall also result in a late withdrawal fine, unless the injury on-site examination provisions or player promotional activity provisions apply as stated under repeal of penalties. In addition, in the case of a 96-draw tournament, if the withdrawal occurs after the qualifying or main draw is made, whichever comes first, the player shall receive a late withdrawal fine, unless the injury on-site examination or player promotional activity provisions apply. Players included in the draw that fail to appear on site shall be classified as a late withdrawal.

### **Whom To Fine?**

**Case:** Player A and player B agree to play doubles together in a tournament, so player B signs the team in to play. On Monday,

## VII. THE COMPETITION

player A withdraws from singles and consequently from doubles. As player A does not come on site for promotional activities, he is aware that he will get a withdrawal penalty for singles. What penalties apply to the doubles team?

**Decision:** Player A gets a fine for doubles while player B does not as he is on site. Even if player B was not on site, he would not be penalized as he did not cause the withdrawal.

**Note:** If player A and player B were only playing doubles and if player A denies agreeing to play with player B then both players are penalized with a fine unless one of the team accepts responsibility for signing the team in.

### **D. No Play After Withdrawal**

- 1) If a player withdraws after the entry/withdrawal deadline from the singles or doubles event of a Grand Slam, ATP World Tour, ATP Challenger Tour, or Futures tournament or the qualifying competition of an ATP World Tour Masters 1000 or ATP World Tour 500 tournament for any reason, he may not play in any other tournament or special event during that tournament week.
  - 2) If the withdrawal occurs prior to 12 noon, Eastern Time, USA, on Friday before the tournament week, then the player may not enter or compete in the doubles event of such tournament or any other tournament or event that week. If the withdrawal was for medical reasons and was after 12 noon Eastern Time, USA, on Friday before the tournament week or the withdrawal was from an ATP World Tour Masters 1000 or ATP World Tour 500 qualifying, then the player may enter and compete in the doubles event of such tournament provided he is determined by the supervisor, upon written medical advice, to be physically capable to compete on a professional level of play.
  - 3) No player may continue playing in an ATP World Tour or ATP Challenger Tour tournament in singles or doubles after giving notice of withdrawal from a tournament scheduled in a future week on account of injury, illness or other medical reason. Players, however, may continue playing in that event if the withdrawal from the future event was for non-medical reasons.
  - 4) The exception to No Play after Withdrawal is the withdrawal of a team accepted into the main draw of an ATP World Tour tournament through the advance entry method due to one or both team members being accepted into the main draw singles of another ATP World Tour or ATP Challenger Tour tournament. In this case, both players may enter a doubles competition, together or separately, through the on-site entry method.
  - 5) A violation of this section shall also be punishable by the provisions set forth in the Code of Conduct.
- E. Withdrawals from the qualifying competition at ATP World Tour Masters 1000 or ATP World Tour 500 tournaments will be without penalty if one of the following occurs:
- 1) Player is accepted into the main draw of the ATP World Tour Masters 1000 or ATP World Tour 500 tournament.
  - 2) The first two (2) withdrawals are excused, thereafter, each withdrawal is subject to a fine in accordance with article 8.03 B., Fines.

## VII. THE COMPETITION

### 7.06 One Tournament Per Week and Exception

#### A. Regulation:

A player may only enter and compete in one Grand Slam, ATP World Tour, ATP Challenger Tour, or Futures tournament or special event during that tournament week. Once a player enters and is accepted into the main draw of singles, doubles, or the qualifying competition, he is committed to that tournament for the week, unless released by the Executive Vice President - Rules & Competition or supervisor. A player who loses in the singles qualifying competition may enter the doubles event of any tournament.

#### B. Exception:

A player who has lost in a tournament may enter the qualifying for a tournament scheduled for the next week. The supervisor may authorize a player who is still competing in the main draw of a tournament in singles and/or doubles to enter the qualifying for the next week's ATP World Tour and ATP Challenger Tour tournaments provided that no special scheduling by either tournament shall be required. In the event of a conflict, he shall be withdrawn from such qualifying so as to compete in the singles and/or doubles of the main draw tournament in which he is competing. In addition, if the player does not appear for play as scheduled, there shall be an automatic fine.

### 7.07 Play-Up Regulation (ATP Challenger Tour Tournaments)

#### A. Restrictions

- 1) Players positioned 1-10 in the South African Airways ATP Rankings (singles) twenty-one (21) days prior to the first Monday of the ATP Challenger Tour tournament are prohibited from entering, accepting a wild card and/or competing in a ATP Challenger Tour tournament. Players who would have been, had they and all other players entered, a direct acceptance on the original acceptance list for a Grand Slam are prohibited from entering, accepting a wild card and/or competing in a ATP Challenger Tour tournament in the first week of the Grand Slam tournament.
- 2) Players positioned 11-50 in the South African Airways ATP Rankings (singles) twenty-one (21) days prior to the first Monday of the ATP Challenger Tour tournament are prohibited from entering but may receive an ATP-approved wild card in order to compete in the Challenger tournament. The Challenger supervisor will make wild card determinations consistent with the limitations outlined below. Players positioned 11-50 are also prohibited from entering, accepting a wild card or competing in ATP Challenger Tour tournaments that offer less than \$50,000 in on-site prize money.
- 3) ATP Challenger Tour tournaments scheduled the same week as an ATP World Tour tournament may offer wild cards to players positioned 11-50 in the South African Airways ATP Rankings (singles) who have received approval from the

## VII. THE COMPETITION

ATP on-site supervisor according to the following breakdown:

\$125,000 in prize money	up to (2) two wild cards
\$100,000 in prize money	up to (1) one wild card
\$75,000 in prize money	up to (1) one wild card
\$50,000 in prize money	up to (1) one wild card
\$35,000 in prize money	no wild card
4) ATP Challenger Tour tournaments not scheduled in the same week as ATP World Tour tournaments, or during the 2nd week of a Grand Slam, ATP World Tour Masters 1000 Miami and Indian Wells, may offer wild cards to players positioned 11-50 in the South African Airways ATP Rankings (singles) who have received approval from the ATP on-site supervisor according to the following breakdown:	
\$125,000 in prize money	up to (4) four wild cards
\$100,000 in prize money	up to (3) three wild cards
\$75,000 in prize money	up to (2) two wild cards
\$50,000 in prize money	up to (1) one wild card
\$35,000 in prize money	no wild card

**NOTE:** These restrictions apply only to **singles** draws.

**Case:** A player ranked between 11-50 asks for a wild card into a \$50,000 ATP Challenger Tour and is denied by the tournament. The player then signs in for the qualifying. Is he allowed to play qualifying?

**Decision:** He is allowed to play only if the tournament grants him a wild card into the qualifying. The WC, however, will not count against the maximum allowed number of 11-50 players for the tournament.

### 7.08 The Draw

#### A. Minimum Draw Size

- 1) The singles draw size for the ATP World Tour Masters 1000 tournaments shall be:

Indian Wells and Miami	96 Draw
ATP World Tour Masters 1000 / Outdoors	56 Draw
ATP World Tour Masters 1000 / Indoors	48 Draw
- 2) With the exception of the Barclays ATP World Tour Finals, the minimum singles draw size for all other ATP World Tour tournaments is as follows:

ATP World Tour 500 / Outdoors	32 Draw
ATP World Tour 500 / Indoors	32 Draw
ATP World Tour 250 / Indoors & Outdoors	28 Draw*

\* ATP World Tour tournaments may petition the ATP for an increased size of the main draw. The deadline for submitting the petition is six (6) months prior to Monday of the tournament week.
- 3) Doubles draw sizes may be found under "Composition of Draws".

## VII. THE COMPETITION

### B. Composition of Draws

1) **Main Draw Singles:** The singles main draw shall be composed as follows:

a) **ATP World Tour Masters 1000 Tournaments:**

Total	Direct	Wild	Special
<u>Accepted</u>	<u>Acceptances</u>	<u>Qualifiers</u>	<u>Cards</u>
48	38-39	6	3
56	44-45	7	4
96	78-79	12	5
			<u>Exempts</u>
			0-1
			0-1
			0-1

b) **ATP World Tour 500 Tournaments:**

Total	Direct	Wild	Special
<u>Accepted</u>	<u>Acceptances</u>	<u>Qualifiers</u>	<u>Cards</u>
32	23-25	4	3-4*
48	36-38	6	4-5*
56	42-44	7	5-6*
			<u>Exempts</u>
			0-1
			0-1
			0-1

\*Applies only for an A+ player from the region

c) **ATP World Tour 250 Tournaments:**

Total	Direct	Wild	Special
<u>Accepted</u>	<u>Acceptances</u>	<u>Qualifiers</u>	<u>Cards</u>
28	19-21	4	3
32	23-25	4	3
48	38-40	4	4
56	45-47	4	5
			<u>Exempts</u>
			0-2
			0-2
			0-2

**NOTE:** All ATP World Tour 250 tournaments shall have a 32 draw qualifying regardless of the size of the main draw.

d) **ATP Challenger Tour Tournaments:**

Total	Direct	Wild	Special
<u>Accepted</u>	<u>Acceptances</u>	<u>Qualifiers</u>	<u>Cards</u>
32	22-24	4	4
			<u>Exempts</u>
			0-2

## VII. THE COMPETITION

2) **Doubles:** The doubles main draw shall be composed as follows:

a) **ATP World Tour Tournaments: Direct Acceptances**

Singles	Doubles	Direct Acceptances	Wild
<u>Draw Size</u>	<u>Draw Size</u>	<u>Advance Entry</u>	<u>On-Site</u>
32	16	10	4
48	16	10	4
48*	24	16	6
56	24	16	6
64	24	16	6
96	32	22	8
		<u>Cards</u>	
			2
			2
			2
			2
			2

\* Denotes ATP World Tour Masters 1000 48 draw singles event

b) **ATP Challenger Tour Tournaments**

Total Accepted	Doubles Direct Acceptances	Qualifiers	Wild Cards
16	12-13	0-1	3

3) **Qualifying:** Sign in for singles qualifying shall be from not before 7 p.m. up to 9 p.m. local time on the night prior to the start of the qualifying competition (Friday night when qualifying commences on Saturday). Once the qualifying competition has begun, only those players who ultimately qualify and lucky losers may be accepted into the main draw. The qualifying competition commences when the first ball of the first qualifying match is struck.

a) **Singles.** ATP World Tour Masters 1000 and ATP World Tour 500 qualifying draw size will be one-half (1/2) the size of the main draw. The qualifying size for all ATP World Tour 250 tournaments shall be 32 with 4 qualifiers. The singles qualifying shall be composed as follows:

i) **ATP World Tour Tournaments - Qualifying:**

Total Accepted	Direct Acceptances	Wild Cards
16	13	3
24	20	4
28	24	4
32	28	4
48	43	5

ii) **ATP Challenger Tour Tournaments - Qualifying:**

Total Accepted	Direct Acceptances	Wild Cards
32	26	6

b) **Doubles Competition.** The doubles qualifying shall be composed as follows:

i) **ATP Challenger Tour Tournaments - Qualifying (Optional):**

Total Accepted	Direct Acceptances	Wild Cards
4	3	1

## VII. THE COMPETITION

### 7.09 Size and Method of Draw

#### A. Main Draw

##### 1) Singles

- a) **28 Competitors.** A draw sheet with 32 places shall be used. After the seeds and byes are placed, the remaining players, including the qualifiers, shall be drawn and placed in the vacant spaces in the draw, beginning at the top of the draw.
- b) **32 or 64 Competitors.** A draw sheet of 32 or 64 places shall be used. After the seeds are placed, the remaining players, including the qualifiers, shall be drawn and placed in the vacant spaces in the draw, beginning at the top of the draw.
- c) **48 or 56 Competitors.** A draw sheet with 64 places shall be used. After the seeds and byes are placed, the remaining players, including the qualifiers, shall be drawn and placed in the vacant spaces in the draw, beginning at the top of the draw.
- d) **96 Competitors.** A draw sheet with 128 places shall be used. After the seeds and byes are placed, the remaining players, including the qualifiers, shall be drawn and placed in the vacant spaces in the draw, beginning at the top of the draw.

##### 2) Doubles

- a) The draw shall be for 16, 24 or 32 teams.
- b) Placing of seeds and byes and the drawing of the remaining teams, including qualifiers, shall be in accordance with the same principles used in the singles main draw.

#### B. Qualifying Draw

The qualifying draw shall be made in sections, and the winner of each section shall be given a place in the main draw, as determined by lot.

##### 1) Singles

- a) If four (4) qualifiers are required, there shall be four (4) sections; six (6) qualifiers, six (6) sections; and so on. The draw shall be seeded and the selection of seeds shall be based on the most recent available and complete South African Airways ATP Rankings (singles) list.
- b) There shall be no pre-qualifying event; however, a tournament may conduct a separate or local event to determine wild cards in the qualifying competition or main draw, and unsuccessful participants in this event are eligible to be considered for entry into the qualifying competition.

##### 2) Doubles (Challengers)

There shall be a four-draw event with one team qualifying.

##### **What Size Draw?**

**Case:** At a 32 draw qualifying event, you only have 15 sign in. How do you handle the placement and distribution of seeds?

**Decision:** You should treat the qualifying draw as a 16 draw with one bye going to the number one (1) seeded player. This principle

## VII. THE COMPETITION

should be used at any draw where you have 1/2 or fewer of the number of players sign in.

##### **Correct When Left Out of Draw**

**Case:** After the 32 qualifying draw has been made, it is discovered that player A, who was properly entered on the sign-in sheet, has been left out of the draw. What is the procedure to correct this mistake?

##### **Decision:**

1. If player A is unseeded, replace the last direct acceptance in the qualifying draw with player A in the draw. Follow this procedure if play has begun unless the last direct acceptance has begun his first match. If the last direct acceptance has started his first match then no correction is to be made and player A is left out of the draw.

2. If player A is seeded, then if he is one of the top four (4) seeds he replaces seed four (4) and then seed four (4) replaces seed eight (8). Seed eight (8) then replaces the last direct acceptance. If player A is to be seeded 5-8, then he shall replace seed eight (8) and then seed eight (8) replaces the last direct acceptance. The same principle is followed for larger qualifying draws where you have a greater number of seeds. If play has begun, then the supervisor shall evaluate the impact upon the draw and correct when possible. If the last direct acceptance has begun play, then no corrections are possible.

##### **Correcting an Error in Seeding**

**Case:** After the event has begun, it is discovered that there has been an error made in the seedings. What action may be taken?

**Decision:** If the players or teams involved in the error have not played their first match, then the error in seeding may be corrected by switching the positions of the affected players or teams.

##### **Don't Have Eight Seeds**

**Case:** In a 32-draw qualifying, there are only seven (7) players listed in the singles or doubles South African Airways ATP Rankings. Since there will not be an eighth seed, how are seeds 5-7 placed in the Draw?

**Decision:** Draw seeds 5, 6 and 7 for placement in sections 2,3 and 4.

##### **I'm In the Main Draw?**

**Case:** In a 32-draw tournament, ten (10) players withdraw prior to the entry deadline. Only eight (8) players are available from the acceptance list to fill the available places. How are the remaining places filled?

**Decision:** The two (2) highest-positioned players on the most recent South African Airways ATP Rankings (singles) or ATP Doubles Rankings that sign in for the qualifying by 9 p.m. are used to fill the two (2) remaining places in the main draw.

**Note:** A player is not permitted to turn down the main draw place in order to play in the qualifying.

## VII. THE COMPETITION

### **Main Draw Seed for a Qualifier**

**Case:** May a player who gains a place in the main draw by qualifying be seeded in the main draw?

**Decision:** Yes. However, if the main draw is made prior to the completion of the qualifying, then the original seedings are final.

### **Who to Seed in singles Qualifying**

**Case:** Seven (7) players listed in the South African Airways ATP Rankings (singles) sign in for the singles qualifying. Two (2) other players listed in the ATP Doubles Rankings sign-in along with fifteen (15) other players. How many and which players will be seeded?

**Decision:** Eight (8) players. The seven (7) singles players and the highest-positioned doubles player.

### **Player Pulled from ATP World Tour 500 Qualifying**

**Case:** ATP World Tour 500 and an ATP World Tour 250 event are being held the same week. Can a player inside the original cut of the ATP World Tour 500 qualifying list be withdrawn in order to be moved into the main draw of the ATP World Tour 250 event or accept a wild card?

**Decision:** Yes

## 7.10 Special Exempts (SE)

### A. Eligibility

Players may receive a special exempt into the main draw of the following week's tournament if they meet the criteria.

- 1) A player is eligible to receive a special exempt into the singles main draw of the following week's tournament, subject to the provisions of this section, if he is unable to compete in that qualifying competition because he is still competing on the date the qualifying competition begins in another qualified event, and his current ranking as of the date of the entry deadline would not have otherwise qualified him as a direct acceptance on the original acceptance list if he had entered. In addition, a player who is still playing a match at 9 p.m. on Friday (the qualifying competition sign-in deadline) is eligible to receive a special exempt only if he wins that match.
  - a) A qualified event for special exempt to a ATP World Tour Masters 1000 tournament is the singles event of another ATP World Tour Masters 1000 or ATP World Tour 500 tournament.
  - b) A Qualified event for special exempt to an ATP World Tour 500 tournament is the singles event of another ATP World Tour 500 or ATP World Tour Masters 1000 tournament.
  - c) A Qualified event for special exempt to an ATP World Tour 250 tournament is the singles event of any ATP World Tour 250, ATP World Tour 500 or ATP World Tour Masters 1000 tournament.
  - d) A Qualified event for special exempt to a ATP Challenger Tour tournament is the singles event of an ATP World Tour or ATP Challenger Tour tournament within the same geographic region, unless there are no Challengers in the same region the following week. If there are no Challengers in the same region the following week, then a qualified event would include all ATP Chal-

## VII. THE COMPETITION

lenger Tour events scheduled in the following week, regardless of region. (Definition of Regions can be found in Exhibit Q).

- e) **EXCEPTION:** A player who has entered and been accepted into the qualifying draw of an ATP World Tour 500 or ATP World Tour Masters 1000 tournament and has been withdrawn because he is still competing, will be added to the last position on the special exempt list of a ATP Challenger Tour tournament scheduled for the next week, even though he would have been a direct acceptance, had he entered the Challenger.

### B. Number of Special Exempts

ATP World Tour Masters 1000 and ATP World Tour 500 tournaments shall have one (1) special exempt and ATP World Tour 250 and ATP Challenger Tour tournaments shall have two (2).

### C. Selection of Special Exempt

- 1) If there are not sufficient special exempt places in the draw for applicants, the players shall be selected according to their position on the most recent South African Airways ATP Rankings (singles) list issued prior to the tournament or by their protected ranking, as long as their protected ranking would not have qualified them as a direct acceptance had they entered. If their protected ranking would have placed them in the main draw had they entered, then the protected ranking cannot be used to determine a player's position on the special exempt list.
- 2) ATP World Tour. If the special exempt places are not needed before the beginning of the qualifying competition, the special exempt places shall be filled by additional direct acceptances selected from the original acceptance list. Thus a player may be pulled out of the qualifying before the first ball is hit and replaced by an alternate list player.
- 3) ATP Challenger Tour. If the special exempt places are not needed prior to the 12 Noon withdrawal deadline, the special exempt places shall be filled by additional direct acceptances selected from the original acceptance list. If the special exempt places have not been determined at the deadline, and then following the 12 Noon withdrawal deadline it is determined that one or both of the places are not needed, the additional direct acceptance(s) shall be filled by the highest ranked player(s) who signed in for the qualifying of that event, including those who have preserved their eligibility.

### D. Special Exempt Process

- 1) A list of possible eligible players is compiled by the player services department by Wednesday/Thursday of the current week for the next week's tournaments.
- 2) The list of eligible players is supplied to the supervisors where the players are competing. The supervisors need to contact each player to inquire if the player is interested in the special exempt position and then contact player relations immediately following the player's decision to remove himself from consideration for any tournament for which he is eligible.
- 3) If the player is interested in an event, player relations coordinates with the supervisors at both events until the SE positions are filled.

## VII. THE COMPETITION

- 4) If the main draw is to be made before a potential special exempt player plays on Friday, then such place(s) shall be drawn in the same manner as qualifier, i.e., four qualifiers ("Q") and one or two "SE" depending on whether there are one or two possibilities. Each of the five or six slots are marked "Q/SE." As soon as the "SE" match results are known, either the "SE" or the next direct acceptance (if the SE lost) is randomly drawn and inserted into the draw.
- 5) If a player does not finish his Friday match by the nine (9) p.m. deadline at the qualifying site and subsequently loses his match, then he is not eligible to be signed in for qualifying or for a special exempt; however, he may receive a wild card from the tournament if it is known before the qualifying draw that he has lost and that no special scheduling shall be required.
- 6) A player who does not appear after accepting a special exempt shall be treated as an entered player and shall receive appropriate penalties.

### **Potential Special Exempt Playing at 9 p.m. Friday**

**Case:** A player is competing in the singles event of a "qualified event" on Friday evening. If the player wins, he will be eligible for a special exempt in a tournament the next week. His singles match, however, will not be completed by 9 p.m. at the qualifying sign-in site for the next week's tournament. How does this affect the "composition of draws" at the next week's tournament?

**Decision:** The special exempt slot in the main draw shall be left available pending the result of the player's match. The qualifying draw should be made as required at 9 p.m. unless it is prudent to wait up to an hour for the match result. If the player vying for the special exempt loses, then the unused special exempt place shall be filled by the next player on the original acceptance list\*. If the next player on the original acceptance list is in the qualifying draw, then he shall be withdrawn and moves into the main draw. The vacancy created in the qualifying draw shall be filled from the qualifying alternate list.

\*For ATP Challenger Tour events, the vacancy is filled with the highest ranked player from the list of those who signed in for the qualifying or properly preserved their eligibility at that event.

### **Potential Special Exempt Loses: After 9 p.m.**

**Case:** A potential special exempt player loses his match at 9:15 p.m. on Friday night and he calls the qualifying sign-in site requesting that he be given a wild card into the singles qualifying competition. May a wild card be given to him for the next week's tournament if the qualifying draw has not been made?

**Decision:** Yes. The wild card belongs to the tournament, which may give it to this player as long as the draw has not been made and no special scheduling is required because of the travel plans of the player.

### **Potential Special Exempt Playing at Midnight Friday**

**Case:** Same situation as above, except that the player's match is still in progress after midnight. Does this make the player eligible for a special exempt based on the fact that he was still competing on the date the qualifying competition begins in another qualified event?

## VII. THE COMPETITION

**Decision:** No. For the purpose of the rule, competing on the date the qualifying competition begins shall be defined as: "Starting or resuming a match as part of that day's (normally Saturday) scheduled program". If the player wins the match, he is eligible to be considered for a special exempt position.

### **Special Exempt Awarded if Player Is in Semis?**

**Case:** A tournament has a Saturday final and a player asks for a special exempt after he wins his quarterfinal match on Thursday. Is he eligible?

**Decision:** No. The player must be scheduled to play on Saturday when the "qualifying begins".

## 7.11 Time of Draw

### A. Main Draw

- 1) **Singles.** The tournament shall publicly make the singles draw no earlier than 12 noon Eastern Time, USA, on Friday prior to the Monday of the tournament week and no later than 10 p.m. local time two (2) days before the first day's play, unless the tournament receives prior written permission from the ATP. The time and place of the draw shall be determined by the tournament.
- 2) **Doubles.** The draw for doubles is to be made as soon as possible after the on-site entry deadline unless otherwise approved by the supervisor. If the draw for a tournament is played over eight (8) or more days, then the draw is to be made by midnight of the second day. Once the draw is finalized there can be no change except for substitution. Doubles main draw matches shall not begin until all doubles qualifying matches are completed unless approved by the supervisor.

### B. Qualifying

- 1) **Singles.** The qualifying competition draw shall be made and the order of play announced as soon as possible on the Friday night following the sign-in deadline.
- 2) **Doubles.** The qualifying competition draw shall be made and the order of play announced as soon as possible following the sign-in deadline unless otherwise determined by the ATP.

## 7.12 Wild Cards

### A. Regulations

- 1) **Singles.**
  - a) Wild cards are players included in the main draw at the sole discretion of the tournament. Wild cards must be named at the time the draw is made. Wild cards may be seeded. Tournaments may not receive compensation and players may not offer compensation in exchange for the awarding of a wild card.
  - b) A wild card is no longer eligible as an alternate at that event.
    - i) A main draw wild card may not be re-classified as a direct acceptance, due to withdrawals, once the draw is finalized.
    - ii) A qualifying wild card is eligible to be moved into the main draw as a direct acceptance, due to withdrawals, up to the start of the qualifying event.
  - c) Once a qualifying competition has commenced (first ball of the first qualifying



## VII. THE COMPETITION

match is struck), an entered player may not be offered nor the player accept a wild card into any tournament that week.

- d) A tournament may not offer a wild card or accept the entry from any player who has either accepted a wild card or been committed by an entry method to another tournament in the same week.

### 2) Singles – ATP World Tour 500

An additional Wild Card is awarded to the tournament with the following restrictions.

- a) The Wild Card must be named no later than 12 Noon, Eastern Time, USA on the Friday before the event week; and
- b) The player must be an A+ player as designated by that event's region.
- c) If the tournament does not use the additional Wild Card by the deadline then the position in the main draw goes to the next eligible player on the entry list.

### 3) Doubles.

A tournament may not enter players as a wild card team without the consent of both players. A wild card may be offered to any team that is not a direct acceptance on the original acceptance list after entries have closed. A wild card may be offered to one player on an entered team if it is conditioned on his playing with a specific player. Wild cards must be named at the time the draw is made. Wild cards may be seeded. Tournaments may not receive compensation and players may not offer compensation in exchange for the awarding of a wild card.

## B. Limitation

- 1) **Singles.** Players may accept up to five (5) main draw singles wild cards into ATP World Tour tournaments during any ATP Circuit Year. Wild cards shall only count toward the annual limit if the player would have been a direct acceptance on the original acceptance list. Additional exceptions are outlined below.

- a) Players who cannot participate in ATP World Tour tournaments and ATP Challenger Tour tournaments for six (6) months because of a physical injury may petition the ATP for one additional wild card.
- b) In the event that a player's position in the South African Airways ATP Rankings (singles) is insufficient to make him a direct acceptance on the forty-two (42) day acceptance list, then he shall be released from his commitment to that tournament, unless offered a wild card to the contract tournament within twenty-four (24) hours of the entry deadline. Such wild card accepted by a player shall not count in the player's annual limitation of five (5) wild cards in singles.
- c) Any player who becomes thirty-five (35) years of age by December 31 of an ATP circuit year shall be exempt from the wild card limitation if he is:
  - i) A former singles Champion of a Grand Slam; or
  - ii) A former singles Champion of the ATP World Championships, Tennis Masters Cup or Barclays ATP World Tour Finals; or
  - iii) A former No. 1 ranked player in the ATP Rankings (singles) prior to January 2000; or
  - iv) A former No. 1 player in the year-end ATP Rankings (singles).
- d) Players may petition the ATP for exceptions to these limitations.

- 2) **Doubles.** There shall be no limitations of doubles wild cards for players.

## VII. THE COMPETITION

### Two Chances

**Case:** Can a player who loses in the qualifying receive a wild card into the main draw?

**Decision:** No.

### Wild Card After ATP World Tour 500 Qualifying Withdrawal

**Case:** A player withdraws from the qualifying of an ATP World Tour 500 tournament on Friday because he is still competing in a ATP Challenger Tour tournament. The player is offered a wild card in another ATP Challenger Tour event to be held the following week. May the player accept the wild card or do the provisions of "No Play After Late Withdrawal" apply?

**Decision:** The player is allowed to accept the wild card. Because the player was competing in a qualified event on the Friday, he is allowed to withdraw from the ATP World Tour 500 qualifying event without penalty and therefore it is not considered as a "Late Withdrawal".

### Wild Card Pulled from Qualifying

**Case:** After the qualifying draw has been made but before the qualifying competition has officially begun, may a player who is included in the qualifying draw be offered and accept a wild card into that tournament's main draw?

**Decision: Yes.** As long as the qualifying competition has not begun (first ball is struck), a player may accept a wild card into the main draw of the ATP World Tour or ATP Challenger Tour tournament where he was included in the qualifying draw and be withdrawn from that qualifying event. The vacancy created in the qualifying shall be filled by an eligible alternate.

### Unused Wild Cards

**Case:** A tournament elects not to use all of its main draw singles wild cards. How are these spots filled?

**Decision:** If the qualifying has not begun, the next player on the acceptance list is moved into the main draw. If qualifying has begun, a lucky loser is to be inserted into the main draw.

## 7.13 Selection of Entries

### A. Singles Main Draw

- 1) **Direct Acceptances.** Direct acceptances are players accepted directly in the draw by virtue of their position in the South African Airways ATP Rankings (singles) or by their protected ranking position. The list to be used for ATP World Tour tournaments shall be dated approximately forty-two (42) days prior to the Monday of the (first) tournament week and twenty-one (21) days prior to the Monday of the tournament week for ATP Challenger Tour tournaments.
- 2) **Qualifiers.** Qualifiers are players who are included in the main draw as a result of their success in a qualifying competition. If the main draw is made prior to the completion of a qualifying competition, it shall include as many qualifying places as there are sections in the qualifying draw. Each of these qualifying places shall be positioned in the main draw in accordance with standard drawing procedures.

## VII. THE COMPETITION

Determination as to which qualifier goes into which qualifying place shall be by drawing after the qualifying competition ends.

- 3) **Special Exempts (SE).** Players may receive a special exempt into the main draw of the following week's tournament if they meet the criteria and apply for it. If the main draw is to be made before a potential special exempt player plays on Friday, then such place(s) shall be drawn in the same manner as qualifier, i.e., four qualifiers ("Q") and one or two "SE" depending on whether there are one or two possibilities. Each of the five or six slots are marked "Q/SE." As soon as the "SE" match results are known, either the "SE" or the next direct acceptance (if the SE lost) is randomly drawn and inserted into the draw.
- 4) **Wild Cards.** Wild cards are players included in the main draw at the sole discretion of the tournament.\* Wild cards must be named at the time the draw is made. Wild cards may be seeded. Tournaments may not receive compensation and Players may not offer compensation in exchange for the awarding of a wild card.

\* See 7.12 A. 2) above for restrictions pertaining to the ATP World Tour 500 additional Wild Card.

### **May I Accept a Challenger Wild Card after Losing in an ATP World Tour Qualifying?**

**Case:** Can a tournament director at a Challenger, which is held in the same week as an ATP event, request permission to offer a main draw wild card to a player who has lost in the qualifying of the ATP World Tour event?

**Decision:** No. A player may only compete in one tournament per week.

### **May I Play Grand Slam Qualifying After Losing in an ATP World Tour tournament?**

**Case:** Can a player lose in the main draw of an ATP event, which is held the week before a Grand Slam tournament, and be eligible to compete in the qualifying for the Grand Slam event that is held that same week?

**Decision:** Yes, as long as he meets the entry deadline set by the Grand Slam event. The player is not violating the one tournament per week rule because the main draws for the two events are in different weeks.

### **May I Accept a Wild Card after Withdrawing from an ATP World Tour 500 Qualifying?**

**Case:** A player was still competing in a Challenger on the day before Q's started at an ATP World Tour 500 event. He wanted to withdraw from the Q's due to "still competing" and then take a wild card into a Challenger event. Is this allowed?

**Decision:** Yes. The rule states that he may withdraw without penalty from the qualifying if he is still competing on the day prior to the commencement of the qualifying. The "without penalty" would relieve him from the "No Play After Withdrawal" provisions of the rules.

### **May I Sign In for Doubles after Withdrawing from an ATP World Tour 500 Qualifying?**

**Case:** A player was still competing on the day before Q's started at

## VII. THE COMPETITION

an ATP World Tour 500 event. He wanted to withdraw from the Q's due to "still competing" and then sign in for doubles at the same or other event. Is this allowed?

**Decision:** Yes. The rule states that he may withdraw without penalty from the qualifying if he is still competing on the day prior to the commencement of the qualifying. The "without penalty" would relieve him from the "No Play After Withdrawal" provisions of the rules.

### **B. Singles Qualifying**

- 1) Direct acceptances shall first be selected from players who sign in with the highest position on the most recent South African Airways ATP Rankings (singles) list, including a protected ranking.
- 2) If there are still places available for direct acceptances in the qualifying draw, the next players selected shall be those with the highest position on the most recent ATP Doubles Rankings list.
- 3) If there are still places available, the tournament shall be awarded additional wild card positions equal to the number of places available. The tournament may, at its option, choose to fill all, or some, of those places with these additional wild card designations.
- 4) There shall be an alternate sign-in list comprised of players that sign in who are not selected as direct acceptances. In the event that direct acceptance players are not present for first-round qualifying matches or if players are moved into the main draw from the qualifying (before the first ball is hit), players shall be selected from the alternate sign-in list in the order described in sections 1), and 2) above. Alternate sign-in deadline is 9:00 pm local time the day before the start of the qualifying. Thereafter, the deadline is one half (1/2) hour before the first scheduled match each day an Alternate may be required.
- 5) Any vacancy created by the withdrawal of a seed, after the qualifying draw has been made but prior to the release of the order of play for the first day of the qualifying event, shall be filled by the next highest positioned player or team in the qualifying draw eligible to be seeded. The position vacated by that next highest positioned player or team shall then be filled by the next eligible player or team on the qualifying draw alternate list.

### **All Ranked Players Have Been Accepted and...**

**Case:** The tournament has elected not to use their wild card allocation to fill the qualifying draw with unranked players. Are they eligible to sign in as alternates?

**Decision:** No. Unranked players are only allowed into the draw as a wild card selection.

### **Fill by Random or Alternative Method**

**Case:** After concluding the qualifying sign-in, there are not a sufficient number of players listed in the South African Airways ATP Rankings (singles) or the ATP Doubles Rankings to fill the draw. If there are still additional vacancies, may the tournament director fill the remaining spots with players according to the local system?

**Decision:** No. The remaining spots are designated as additional

## VII. THE COMPETITION

*wild cards and may be assigned all or in part at the discretion of the tournament director.*

### C. Doubles Main Draw - ATP World Tour and ATP Challenger Tour

Direct acceptances for ATP World Tour and ATP Challenger Tour events shall be in the following order:

- 1) Teams composed of players in either the South African Airways ATP Rankings (singles) or the ATP Doubles Rankings. The combined positions of the two players (using best singles or doubles ranking) shall be added together and the total used to determine the direct acceptances. The most recent South African Airways ATP Rankings (singles) and/or ATP Doubles Rankings list, including a protected ranking, shall be used. Ties shall be resolved as follows:
  - a) Team using two (2) singles rankings.
  - b) Team using one (1) singles ranking.
  - c) A team using a protected ranking is positioned below the other team(s); if one player on each team is using a protected ranking then the position of each remaining player determines which team is positioned higher.
  - d) For ties between teams with the same composition, priority will be given to the team with the strongest individual singles ranking, including protected ranking, or for teams using two doubles rankings, the fewest number of tournaments played and then the team with the highest number of points.
- 2) If the doubles draw cannot be filled by teams with at least one member who is listed in the South African Airways ATP Rankings (singles) or ATP Doubles Rankings:
  - a) **ATP World Tour** - the remaining places shall be filled with byes.
  - b) **ATP Challenger Tour** - the remaining places shall be filled with byes.

#### **Use of Both Rankings**

**Case:** *A player has a protected singles ranking of 201, true singles ranking of 458, protected doubles ranking of 320 and true doubles ranking of 408. Can the player use his protected singles ranking to enter doubles when he has already used it to enter the singles of that tournament or does he have to use his 'true' singles ranking or his protected doubles ranking?*

**Decision:** *The protected singles ranking CAN be used for entry into the doubles. It would not count against his allowed total for singles events but would count against his doubles allotment.*

### D. Seeds - ATP World Tour and ATP Challenger Tour

Seeded teams will be determined by using the combined doubles ranking of the two players (protected ranking not included). Ties shall be broken as follows:

- 1) The team with the fewest events played is positioned higher.
- 2) The team with the highest number of points is positioned higher.
- 3) A coin flip or draw if a tie remains.

## VII. THE COMPETITION

### E. Qualifiers

Qualifiers are teams who are included in the main draw as a result of their success in a qualifying competition. If the main draw is made prior to the completion of a qualifying competition, it shall include as many qualifying places as there are sections in the qualifying draw. Each of these qualifying places shall be positioned in the main draw in accordance with standard drawing procedures. Determination as to which qualifier goes into which qualifying place shall be by drawing after the qualifying competition ends.

### F. Wild Cards

Wild cards are players included in the main draw at the sole discretion of the tournament. Wild cards must be named at the time the draw is made. Wild cards may be seeded. Tournaments may not receive compensation and players may not offer compensation in exchange for the awarding of a wild card.

### 7.14 Seeds Definition

Seeds are players who are given preferential positions in the draw based on the ATP Ranking. The selection and arrangement of seeds shall be based upon the most recent ATP Ranking list (the protected ranking is not considered). Each tournament shall have a seeded draw and there shall be only one seeding list. Seeding shall not be official until the final draw is made. For doubles, seeded teams will be determined by using the combined doubles ranking of the two players (entry protection not included).

Any vacancy created by the withdrawal of a seed, after the draw has been made but prior to the release of the order of play for the first day of main draw, shall be filled according to the procedures described under vacancies.

#### **Protected Ranking is for Entry, Not Seeding**

**Case:** *May a player's protected ranking be used for seeding purposes?*

**Decision:** *No. The protected ranking position can be used for: 1) entry into the qualifying competition and main draw, or 2) special exempt position. It may not be used for: 1) seeding, or 2) lucky loser order.*

## VII. THE COMPETITION

### 7.15 Number of Seeds

The number of seeds shall be as follows:

<u>Singles</u>		<u>Doubles</u>	
16 competitors -	8 seeds (singles Q)	4 teams -	2 seeds (Qualifying)
24 competitors -	12 seeds (singles Q)	16 teams -	4 seeds
28 competitors -	14 seeds (singles Q)	24 teams -	8 seeds
32 competitors -	8 seeds (singles (Q))	32 teams -	8 seeds
48 competitors -	24 seeds (singles Q)		
28 competitors -	8 seeds		
32 competitors -	8 seeds		
48 competitors -	16 seeds		
56 competitors -	16 seeds		
96 competitors -	32 seeds		

### 7.16 Placement of Seeds - Main Draw

The procedures for placing seeds in the main draw are as follows:

- A. Place seed 1 on line 1 and seed 2 on line 32 (32 draw), line 64 (64 draw) or line 128 (96 draw); and

## VII. THE COMPETITION

- B. To determine the location of the remaining seeds, draw in groups according to the following chart:

<u>Seeds</u>	<u>16 Draw</u>	<u>32 Draw</u>	<u>64 Draw</u>	<u>96 Draw</u>
	<u>4 Seeds</u>	<u>8 Seeds</u>	<u>16 Seeds</u>	<u>32 Seeds</u>
<u>3-4</u>				
First Drawn	5	9	17	33
Second Drawn	12	24	48	96
<u>5 - 8</u>				
First Drawn		8	16	32
Second Drawn		16	32	64
Third Drawn		17	33	65
Fourth Drawn		25	49	97
<u>9-12</u>				
First Drawn			9	17
Second Drawn			25	49
Third Drawn			40	80
Fourth Drawn			56	112
<u>13 - 16</u>				
First Drawn			8	16
Second Drawn			24	48
Third Drawn			41	81
Fourth Drawn			57	113
<u>17 - 24</u>				
First Drawn				9
Second Drawn				24
Third Drawn				41
Fourth Drawn				56
Fifth Drawn				73
Sixth Drawn				88
Seventh Drawn				105
Eighth Drawn				120
<u>25 - 32</u>				
First Drawn				8
Second Drawn				25
Third Drawn				40
Fourth Drawn				57
Fifth Drawn				72
Sixth Drawn				89
Seventh Drawn				104
Eighth Drawn				121

### 7.17 Qualifying Placement

#### A. Singles

- There will be one section, having two (2) seeds, for each qualifying position in the main draw. The first seed shall be placed at the top of the first section. The second seed shall be placed at the top of the second section and so on until all sections have one (1) seed on the top line of each section. The remaining seeds shall be

## VII. THE COMPETITION

placed together and drawn with the first drawn placed on the last line of the first section, second drawn placed on the last line of the second section and continued in this manner until each of the sections have two seeds.

- 2) The names of the remaining players shall be drawn and placed in the vacant spaces not occupied by the seeds or byes beginning at the top of the draw.

### B. Doubles

- 1) Two teams shall be seeded in a four-draw event with the seeds being placed on lines 1 and 4.

## 7.18 Byes - Assignment and Placement

### A. Singles Main Draw

- 1) If there is a 32 main draw, no byes shall be awarded unless there are an insufficient number of direct acceptances.
- 2) If there is a 28 main draw, the top four (4) seeds shall be awarded a bye.
- 3) If there is a 48 or 96 main draw, each seed shall be awarded a bye.
- 4) If there is a 56 main draw, the top eight (8) seeds shall be awarded a bye.
- 5) Any player who received a “bye” and loses in the second round shall receive second round loser’s prize money but only first round loser’s points for the South African Airways ATP Rankings (singles), if applicable.

### B. Doubles Main Draw

- 1) If there is a 16 or 32 main draw, no byes shall be awarded.
- 2) If there is a 24 main draw, each seeded team shall be awarded a bye.
- 3) Any team that received a “bye” and loses in the second round shall receive second round loser’s prize money but only first round loser’s points for the South African Airways ATP Rankings (doubles), if applicable.

### C. Qualifying Draw

If there are not enough competitors to fill the qualifying draw, then after the seeds are placed in the draw, the required number of byes shall be awarded as follows:

- 1) Priority shall be to the highest seeds.
- 2) Remaining byes shall be drawn by groups of two (2) going into one (1) section (e.g., if there are 10 byes, eight go to seeds and the remaining two are drawn into one section; if there are 11 byes, nine and 10 are drawn into one section and the 11th is randomly drawn into one of the other three (for a 32 draw qualifying competition) remaining qualifying sections).

## 7.19 Remake of Draw

### A. Singles

If two (2) or more of the top eight (8) seeds withdraw more than twenty-four (24) hours before the start of the singles tournament, the tournament may choose either

## VII. THE COMPETITION

to remake the draw or let the draw stand. If a wild card withdraws after the original draw and the draw is to be remade, the vacancy created may be filled at the tournament’s option by a substitute wild card. If the tournament elects not to use a substitute wild card, the vacancy shall be treated as any other vacancy.

### B. Doubles

Prior to the draw being finalized (not sooner than when it is published but not later than when the first ball of the doubles tournament is struck as determined by the supervisor), use the following procedure: If one-fourth or more of the seeded teams withdraw, or a minimum of two (2) seeded teams in a 16-team draw withdraw, the tournament director has the option to have the draw remade if approved by the supervisor. If the draw is remade, the original pairings may not be changed except where vacancies occur.

## 7.20 Lucky Losers, Substitutions and Vacancies

### A. Lucky Loser Selection

A player may be entered in the main draw of a tournament if he meets the criteria outlined for a lucky loser.

- 1) Lucky losers are players who have lost in the final round of the qualifying event or, if more lucky losers are required, those players who have lost in the previous qualifying round(s). The lucky losers shall be selected on the basis of their position on the ATP rankings (singles or doubles) list used for the determination of qualifying seeding (protected ranking is not considered); that is, the lucky loser with the highest entry ranking position shall be the first inserted into the main draw and so forth. Only those accepted into the qualifying competition may sign in as lucky losers.
- 2) The lucky loser list shall be posted each day at least one (1) hour before the sign-in deadline, which shall be one-half (1/2) hour before the first scheduled match of the day. If rain or other disruptions occur, then the supervisor can change the deadline as appropriate. Such list shall not be available for sign-in on the preceding day. All lucky loser sign-in deadlines must be placed on each day’s schedule of play.
- 3) The sign-in for doubles lucky losers or alternates shall follow the same procedures as the sign-in for singles lucky losers or alternates. One member of a lucky loser team may sign in for the team. If there is no qualifying competition, substitutions shall come from the alternate list of teams not accepted directly into the main draw and shall follow the acceptance procedures outlined above. In either case, only substitutions of the originally paired teams are permitted. If two (2) or more positions become available at the same time during the preceding period, the positions to be occupied shall be determined by drawing.
  - a) There shall be one alternate sign-in sheet that will have all eligible alternate teams listed.
  - b) The system of merit is based on the same method as used in the system of merit for entry.

*Case: A team submits an advance entry for a 250 tournament with one of the players using a protected ranking. They are among 6*

## VII. THE COMPETITION

teams not ranked high enough to be selected. The other 5 teams are using their best of rankings. Where is the team using the protected ranking placed on the alternate list if they are the next team in based on that ranking or the 4th highest team using their best of ranking?

**Decision:** The team using the protected ranking is placed at the top of the alternate list. Protected ranking is used for entry into a tournament either directly or as an alternate (either an advanced entry or as an on site entry).

### B. Lucky Loser Substitution

- 1) A lucky loser shall be inserted in the appropriate position as a substitution for any player who withdraws or is withdrawn before the first ball of his first match is struck.

**NOTE:** A player winning a match by walkover is considered to have played a match.

- 2) In order to be eligible for substitution, a lucky loser must:
  - a) Sign the lucky loser sign-in record at least one-half (1/2) hour prior to the first scheduled match of each day; and
  - b) Be ready to play within five (5) minutes after the announcement of a default for punctuality.
  - c) If the eligible lucky loser is not available to play, he shall be placed at the bottom of the lucky loser priority list for that day corresponding to the qualifying round in which he lost. If the eligible player is playing in the doubles event at the time he is called as a lucky loser in singles, the singles match may be rescheduled so he can fill the lucky loser position, provided the supervisor determines that the rescheduling does not cause an unreasonable disruption of the schedule or does not cause the winner to play a second match that day; otherwise the next available lucky loser shall be selected to fill such vacancy.

### Alternate Sign-In Procedures

**Case:** The two (2) players ahead on an alternate list do not sign in 1/2 hour before the singles qualifying matches are to begin. One (1) of the players arrives on-site just before it is known that an alternate is going to be needed. Who gets in?

**Decision:** Neither of the two (2) players. In order to be eligible for substitution, an alternate must sign in before the deadline and must be ready to play within five (5) minutes of being called.

### Doubles Alternate at two tournaments?

**Case:** A team signs in for doubles at two tournaments the same week. They do not get into the main draw, but are the #1 alternate at both events. The team signs the Alternate list at tournament A on Monday and Tuesday and then wants to sign the Alternate list at tournament B on Wednesday. Are they permitted to do this?

**Decision:** Yes, however, a team is only eligible to be signed in on one "live" list per day.

### Eligible for Lucky Loser

**Case:** May a player or team sign the lucky loser sign-in sheet if they

## VII. THE COMPETITION

are not accepted into the qualifying competition?

**Decision:** No. To be eligible as a lucky loser, a player or team must have played and lost in the qualifying event.

### Extending Closing Times

**Case:** The first-round singles matches are scheduled to start at 10 a.m. A steady rain is falling at 9 a.m. and it is decided to postpone the start of play until 11 a.m. should the lucky loser sign-in be extended?

**Decision:** Yes. Extend the deadline to 10:30 a.m.

**Case:** The lucky loser Sign-in closed at 10:30. A player arrives at 10:45 to sign in saying that:

1. The referee told me that the deadline would be at 11:00; or
2. Somebody on the phone said the deadline was 11:00; or
3. Tournament transportation was 45 minutes late.

### Decision:

1. Allow the player to sign in. Information given by the referee (if verified) must be honored.
2. Sign-in not allowed. Players receiving information over the phone do so at their own risk unless they speak directly to the supervisor or referee.
3. Sign-in not allowed. The player is responsible for arriving on time.

### Which Lucky Loser to Insert?

**Case:** On Monday before the last singles match has gone on court, a player whose first-round singles match is scheduled for Tuesday is forced to withdraw because of injury. No one signed the lucky loser list on Monday. How is the vacancy resolved?

**Decision:** The vacancy should be filled from Monday's lucky loser list. However, since no one signed the lucky loser list on Monday, the vacancy shall be filled from the Tuesday lucky loser list, if any eligible players sign in. If no one signs on Tuesday, then a walkover shall be awarded.

### Who Goes In?

**Case:** A player withdraws from the singles event on Tuesday. His singles match was not scheduled until Wednesday. There was a singles lucky loser sign-in on Tuesday. The last singles match scheduled for Tuesday has not gone on court. Is the vacancy filled from Tuesday or Wednesday's lucky loser sign-in?

**Decision:** Tuesday's sign-in.

### C. Vacancies - Doubles

#### ATP World Tour

- 1) A team shall constitute a doubles entry. If either of the players of a team cannot play, that doubles entry is subject to withdrawal and substitution.
- 2) If the withdrawal is from the advance acceptance list and prior to 12 Noon (EST) on the Friday before the event, then the next team on the alternate list is moved into the main draw.

## VII. THE COMPETITION

- 3) If the withdrawal is from the advance acceptance list and occurs after the 12 Noon (EST) deadline then an additional on-site entry position is created for each withdrawal.
  - a) For both 2 and 3 above, the partner of the withdrawing player may enter the same or another event through the on-site entry method; or
  - b) If the withdrawal was due to one or both players being accepted into the main draw singles of another ATP World Tour or ATP Challenger Tour event, then both players may enter the doubles of that event through the appropriate on-site entry procedure.
- 4) If a player from a team that is a direct acceptance withdraws based on a medical reason or other unavoidable circumstances after the on-site sign-in deadline but before the draw, his partner may enter again with another player who has not already been accepted into the main draw doubles event. This new team may be considered for acceptance based on its position in the on-site entry list including any entry protection position.

### ATP Challenger Tour

- 1) A team shall constitute a doubles entry. If either of the players of a team cannot play, that doubles entry is subject to withdrawal and substitution.
- 2) If a player from a team that is a direct acceptance either in the main draw or qualifying withdraws based on a medical reason or other unavoidable circumstances after the on-site sign-in deadline but before the draw, his partner may enter again with another player who has not already been accepted into the qualifying or main draw doubles event. This new team may be considered for acceptance based on its position in the entry list including any entry protection position.

#### **Partner Injured: Who May Replace Him?**

**Case:** A player's doubles partner withdraws after the on-site sign-in deadline but before the draw is made. In looking for a new partner, is the withdrawing player's partner allowed to choose another partner from the qualifying draw?

**Decision:** No. The player seeking a new partner may not team with any player who is accepted into the qualifying or main draw. He may re-enter with any player that he chooses as long as their combined position in the ATP entry ranking qualifies them by virtue of the system of merit for doubles entries. He may not select from players who will be or who are in the qualifying draw based on the sign-in sheet.

#### **Remake of the Draw**

**Case:** On Monday morning, two (2) of the four (4) seeded teams withdraw from a 16-draw doubles event. The doubles competition has not yet begun. May the draw be remade?

**Decision:** Yes. However, it is the option of the tournament.

### D. Prior to Qualifying Competition

- 1) **ATP World Tour.** After the main draw is made and prior to the commencement of the qualifying competition, all vacancies created by the withdrawal of unseeded players or teams, including wild card withdrawals, shall be filled by the next highest positioned player(s) on the original acceptance list. If the vacancy was created

## VII. THE COMPETITION

by the withdrawal of a seed, then the procedures for replacing seeds are followed and the vacancy created by replacing the seed is filled by the next highest positioned player(s) on the original acceptance list.

- 2) **ATP Challenger Tour.** After the main draw is made and prior to the commencement of the qualifying competition, all vacancies created by the withdrawal of unseeded players or teams, including wild card withdrawals, shall be filled by the next highest positioned player(s) from that event's qualifying sign-in list and players from the original alternate list who have contacted the on-site Supervisor prior to the qualifying sign-in deadline and preserved their eligibility on the new alternate list. If the vacancy was created by the withdrawal of a seed, then the procedures for replacing seeds are followed and the vacancy created by replacing the seed is filled by the next highest positioned player(s) from that event's qualifying sign-in list, including those players who have preserved their status on the new alternate list.

#### **Main Draw Vacancy Before Qualifying Starts**

**Case:** After making the qualifying draw, a vacancy occurs in the main draw. How is the vacancy filled?

**Decision:** If the qualifying competition has begun, the vacancy is filled by the eligible lucky loser. If the qualifying competition has not begun, the vacancy is filled as follows:

**ATP World Tour events:** by the next player on the original acceptance list.

**ATP Challenger Tour events:** the highest ranked player who signed in for the qualifying competition, including those who have preserved their eligibility.

### E. Qualifying started or finished

- 1) **During Qualifying Competition.** If a lucky loser position should become available during the qualifying competition, it shall be treated the same as the qualifying places for placement in the main draw. If a seeded player or team withdraws after the main draw has been made but prior to the release of the order of play for the first day of main draw, the vacancy created by the withdrawal of a seed shall be filled by the following method:
  - a) **16/24 (Doubles)/32/48/64 and 96 Draw.** The vacancy shall be filled by the next highest positioned player or team in the main draw eligible to be seeded. The appropriate lucky loser shall fill the remaining vacancy.
  - b) **28 Draw.** If the vacancy involves a seed #1-4, then seed #5 moves to the vacated seed position and the next highest positioned player in the main draw eligible to be seeded shall be placed in the position vacated by the #5 seed. The appropriate lucky loser shall fill the remaining vacancy.
  - c) **56 Draw.** If the vacancy involves a seed #1-8, then seed #9 moves to the vacated seed position and the next highest positioned player or team in the main draw eligible to be seeded shall be placed in the position vacated by the #9 seed. The appropriate lucky loser shall fill the remaining vacancy. If the vacancy involves a seed #9-16, then the next highest positioned player or team in the main draw eligible to be seeded shall be placed in the vacated seed position. The appropriate lucky loser shall fill the remaining vacancy.

## VII. THE COMPETITION

### **Seeds Withdraw or Are Withdrawn**

**Case:** The team seeded 4th withdraws after the draw but prior to the order of play being released for the first day of main draw. How is the vacancy filled?

**Decision:** For a 16 team draw, the vacancy created by the removal of a seeded team is filled by the next highest positioned team eligible to be seeded. The appropriate alternate or lucky loser team shall fill the remaining vacancy.

### **Qualifier Eligible To Be Seeded**

**Case:** A qualifier's ranking was high enough for him to be seeded in the main draw. The main draw was completed prior to the end of the qualifying event. After the player had qualified but prior to the order of play being released for the first day of main draw a seeded player withdraws. Is the qualifier eligible to be seeded.

**Decision:** Yes. The successful qualifier shall be accorded the same right to be seeded as the other players who have gained entry as Direct Acceptances, Wild Cards, Special Exempt etc. As per ATP rules a player may not use his Protected Ranking for seed purposes

### **2) Other Vacancy Procedures After Qualifying Starts.**

- a) After the qualifying commences (when the first ball of the first match is struck), vacancies may only be filled by eligible lucky losers.
- b) If a lucky loser position becomes available after the places for qualifiers are drawn for the main draw but before the first day of the main draw event, the highest positioned lucky loser shall be inserted into the draw provided he can be notified.
- c) If a position becomes available during the day, the highest positioned player who has signed that day's lucky loser sign-in record shall be inserted at the time the withdrawal is confirmed.
- d) Positions becoming available after the start of play for the last match of each day in that event (singles or doubles) shall be filled by the highest positioned player who signs the lucky loser sign-in record on the successive day of play.
- e) When two or more positions become available at the same time, the positions to be occupied by each lucky loser shall be determined by drawing.
- f) In all such cases, the supervisor is responsible to notify a player(s) that he is in the draw.

### **When is the withdrawn player replaced?**

**Case:** A player withdraws from the main draw 2 hours prior to the close of the lucky loser sign-in deadline. A few minutes later, the highest ranked lucky loser signs in. There is still one hour left before the lucky loser sign-in deadline closes. As the player who signed-in is the highest ranked LL, is he inserted at that moment, or is the vacancy filled after the sign-in deadline passes?

**Decision:** The player is not inserted in the draw until after the sign-in deadline as others may withdraw necessitating drawing for the available spots. Multiple withdrawals occurring after the last match of that event began on the previous day, and the time that the sign-

## VII. THE COMPETITION

*in deadline closes on the next day, are considered to have occurred at the same time and the positions to be occupied by each lucky loser shall be determined by drawing.*

### **7.21 Match Scheduling**

#### **A. Scheduling Committee**

The scheduling of matches and daily order of play in all tournaments shall be prepared by the referee and/or tour manager and approved by a committee composed of the tournament director, supervisor, referee and the tour manager. In cases where the scheduling committee cannot agree, the supervisor shall make the final decision.

#### **B. Tournament Week Plan**

- 1) **Main Draw.** The main draw should be scheduled so that the first round in singles begins on Monday and the finals in singles and doubles are completed by Sunday, unless the tournament has special permission from the ATP forty-two (42) days in advance of the event to complete the tournament on Saturday or on Monday.
  - a) **Considerations and Priorities.** The following priorities in the order listed should be followed:
    - i) Schedule the halves of the draw together particularly from Wednesday onward. At indoor tournaments, second rounds can be split within sections if necessary to avoid Monday/Thursday (singles).
    - ii) Schedule quarters together as an alternative.
    - iii) Avoid Monday/Thursday (singles) or Tuesday/Friday (doubles). Schedule some doubles on Monday.
    - iv) The singles quarterfinal matches on Friday should be scheduled by halves and as close together as possible.
    - v) Schedule one doubles semifinal on Friday (cannot be done if there are two Saturday sessions).
    - vi) When weather or other unavoidable circumstances cause a disruption in the schedule, a player may not be scheduled for more than three (3) matches in a day without his consent.
      1. The matches may not all be singles without the consent of the player.
      2. Completion of a match in progress shall count as one (1) match.
- 2) **Qualifying.** The qualifying event for singles should be scheduled for completion on the day before the commencement of play in the main draw. If conditions force the qualifying matches to be played on the same day of the main draw, then all qualifying matches should be completed before the main draw begins, unless otherwise approved by the supervisor. Matches should be scheduled so that a player shall not be required to play more than two (2) qualifying matches in the same day, except when weather or unavoidable circumstances cause schedule disruption. Whenever more than one round of qualifying must be played in one day, the order of play should conform to the order of the draw, top to bottom or bottom to top, or at a minimum, by sections.
  - a) Normally, two (2) rounds of singles will be played on Saturday and one (1) round on Sunday. The tournament, with ATP approval, may play the qualifying over three (3) days.
  - b) In ATP World Tour Masters 1000 and ATP World Tour 500 events, one round



## VII. THE COMPETITION

shall be played on Saturday and the final round shall be played on Sunday except when weather or other unavoidable circumstances forces two rounds to be played on Sunday.

- c) Doubles qualifying should be played at ATP Challenger Tour tournaments on Sunday and the final match may be scheduled for early Monday, if necessary.

### C. Daily Scheduling Overview

- 1) Feature singles matches should be scheduled after the scheduling committee considers the needs of players, television, tournament and the public. It is recommended that a tournament schedule no more than two (2) evening matches to begin no later than 8 p.m. local time.
- 2) The scheduling committee must schedule a doubles match on all show courts (including Centre Court) as follows:

#### **ATP World Tour 250 (16 draw doubles)**

- o Seven (7) doubles matches must be scheduled on the Centre Court during the tournament week.

#### **ATP World Tour 250 (24 draw doubles)**

- o Seven (7) doubles matches must be scheduled on the Centre Court during the tournament week.
- o Four (4) doubles matches must be scheduled on the Grandstand or second court.

#### **ATP World Tour 500 (16 draw doubles)**

- o Seven (7) doubles matches must be scheduled on the Centre Court during the tournament week.

#### **ATP World Tour 500 (24 draw doubles)**

- o Seven (7) doubles matches must be scheduled on the Centre Court during the tournament week.
- o Four (4) doubles matches must be scheduled on the Grandstand or second court.

#### **ATP World Tour Masters 1000 (24 draw doubles)**

- o Seven (7) doubles matches must be scheduled on the Centre Court during the tournament week.
- o Seven (7) doubles matches must be scheduled on the next two (2) best courts with at least four (4) out of the seven (7) scheduled on the second overall best court.

#### **ATP World Tour Masters 1000 (32 draw doubles)**

- o Seven (7) doubles matches must be scheduled on the Centre Court during the tournament week.
- o Nine (9) doubles matches must be scheduled on the next two (2) best courts with at least four (4) out of the nine (9) scheduled on the second overall best court.

**Final.** The doubles final is to be scheduled prior to the singles final. It is recommended that the time of the final is no earlier than two (2) hours before the singles final, unless otherwise approved by the ATP.

It is further recommended that the tournament begin each session (day and night) with a doubles match as an “opening act”.

If exceptional circumstances do not allow for a doubles match to be scheduled on the Centre Court or a designated show court, then best efforts shall be made by the scheduling committee to schedule an additional doubles

## VII. THE COMPETITION

match on one of the other show courts, if any.

- a) **Exceptional Circumstances may include, but are not limited to, the following:**
- i) Contractual television obligations.
  - ii) Security issues.
  - iii) Weather or other scheduling interruptions.
  - iv) Combined with WTA Tour event.
  - v) Unforeseen circumstances as determined by the scheduling committee.

Definition of show court(s): Centre Court and all other courts that are used to televise matches; or, if only Centre Court is televised, then the next court with the greatest number of spectator seating.

**Violation of this section may subject the Tournament to the penalties set forth in VIII. The Code - section 8.02 Tournament Violations.**

- 3) Normally, matches are scheduled using “to follow on assigned court.” However, assigning feature matches a time or “not before” basis is permissible. The tournament director should understand that scheduling “not before” in a stadium or show courts may result in a court not having a match until the announced time.
- 4) First-round doubles matches can be scheduled on a “not before” basis which will then allow for the fixing of the lucky loser or alternate sign-in deadline.
- 5) Starting matches after Midnight is not recommended (after 1:00 a.m. should be avoided). The supervisor may postpone a match after examining the impact on the tournament and the players.

### D. Order of Play

The daily order of play is the published summary of all matches scheduled for a particular day.

- 1) **Release Deadline.** Once the scheduling committee determines the order of play, it should be released no later than 10 p.m. local time at the tournament.
- 2) **Change.** Once released, the order of play may not be changed except upon the approval of the supervisor.
- 3) **Notification.**
  - a) It is the responsibility of all players to ascertain their schedules from the supervisor/referee for each day's play.
  - b) The supervisor/referee should also use all available means to notify each player of his schedule.
- 4) **Notes / Reminders.** Daily order of play must have footnotes reflecting the following:
  - a) The singles (and doubles) lucky loser sign-in deadline is \_\_\_\_\_ (on appropriate days).
  - b) The alternate sign-in deadline is \_\_\_\_\_ (on appropriate days).
  - c) Final matches on any court or session may be moved.

### E. Calling of Matches

The supervisor determines when a match is to be called. Players must be ready to

## VII. THE COMPETITION

play when their matches are called. The supervisor shall determine when a match is to be called or when a match was in fact called. Schedules and match updates may only be reliably obtained from the supervisor, tour manager or the referee.

### F. Rain

If because of rain, etc., a tournament cannot be completed within the tournament week, then, at the option of the tournament, one (1) extra day shall be allowed. The supervisor shall approve the commencement times for matches on the extra day, which shall then be scheduled during the morning or early afternoon. No further extension of the tournament shall be permitted without the approval of the ATP.

### G. Rest Periods - Minimums and Guidelines

1) **Between Main Draw and Prior Week's Tournament(s).** Before scheduling matches for the first day of play, the supervisor must contact the supervisor(s), referee(s) or tour manager(s) of the preceding week's tournament(s) to determine to what extent players still competing may have difficulties in arriving for play. To the extent possible, and providing it does not jeopardize the fairness of scheduling and the completion of his tournament, matches should be scheduled so that each player with reasonable difficulties can be accommodated. The supervisor shall whenever possible give the player one full day's rest between his last match played in a previous week's tournament or event and the player's first match in the succeeding tournament, unless weather or unavoidable circumstances have caused a schedule disruption or the player was a finalist in a Monday or other delayed final. There shall be no first-round singles matches scheduled to start on Wednesday in 32 draw outdoor tournaments without the approval of the ATP or on-site supervisor. The on-site supervisor shall consider approving Wednesday starts only in the following circumstances:

- a) If a player is competing in a Davis Cup Tie on another continent; or
- b) If a player is competing on the Sunday in a Grand Slam, ATP World Tour, ATP Challenger Tour or Futures tournament, and the following week's tournament is on a different continent; or in a Monday Final on the same continent. Davis Cup Ties on the same continent which are delayed until Monday may also be considered. For the purposes of this rule the world is divided into 7 distinct continents. They are Europe, Asia, Antarctica, Australia, Africa, North America (including Central America) and South America.

In such cases, the match must be scheduled early Wednesday and if the player enters doubles, then he shall be required to play as determined by the supervisor.

The criteria listed in a. and b. above shall not apply in the case where a tournament has been approved for a Saturday final.

- c) Challengers scheduled the second week of a Grand Slam may schedule first-round singles matches on Tuesday and Wednesday provided that scheduling is done by sections.
- 2) **Main Draw and Qualifying.** Other than in exceptional circumstances, no player shall be required to play his first-round match in the singles main draw until at least twelve (12) hours after the completion of his final qualifying match. The following should also be considered:

## VII. THE COMPETITION

- a) If a player plays two (2) rounds of singles qualifying on the first day of qualifying, then the scheduled start time of his final round of qualifying shall be no earlier than eighteen (18) hours from the start time of his second qualifying match.
- b) If a player plays in two (2) singles qualifying matches on Sunday, then he shall not be scheduled to play in a singles main draw match on Monday. However, the player may be scheduled to play, if necessary, a doubles match on Monday.
- c) If a player plays in two (2) doubles qualifying matches on Sunday, then he can be scheduled to play in either one (1) singles or one (1) doubles main draw match on Monday.
- d) If a player plays in one (1) singles qualifying and two (2) doubles qualifying matches on Sunday, then he shall not be scheduled to play on Monday.
- e) If a player plays in one (1) singles qualifying and one (1) doubles qualifying match on Sunday, then he can be scheduled to play in one (1) singles main draw match on Monday. The singles match is to be scheduled early if that player is also playing in a doubles qualifying match (final) on that Monday.
- f) If the final doubles qualifying match is scheduled for Monday, the main draw doubles matches shall be scheduled no earlier than three (3) hours after the final qualifying match. If the main draw doubles match should be scheduled earlier, then it is understood that if a doubles lucky loser is required, the match shall be re-scheduled with that lucky loser inserted.
- g) Any player who becomes a lucky loser may be scheduled to play on Monday regardless of the number of matches that he has competed in on Sunday. Except, however, a player who played in three (3) matches on Sunday may only play one (1) match (singles) on Monday. If the player is to be required to be a doubles lucky loser or is scheduled to play a main draw doubles match, the doubles match would be rescheduled when his team is inserted into the draw unless the supervisor determines the schedule shall be adversely affected.

### 3) Between Main Draw Matches.

- a) Players shall not be scheduled to play in a match within twelve (12) hours after completing his last match the preceding day.
- b) Players shall not be scheduled for more than one (1) singles and one (1) doubles match per day, unless weather or other unavoidable circumstances have caused schedule disruptions. Completion of a match in progress shall count as one (1) match.
- c) A player's singles match on any particular day shall be scheduled before his doubles match(es) unless otherwise directed by the supervisor. Even without a schedule disruption, a player may be scheduled for two (2) doubles matches if he is not scheduled to play in singles that day.
- d) Whenever it is necessary to schedule a player to compete in more than one match in the same day, a player shall be given the following minimum rest periods (other factors may result in more time being authorized) unless he is in a singles and doubles finals to be played consecutively:

	<u>Outdoor</u>	<u>Indoor</u>
i) If he has played less than 1 hour	30 min. rest	30 min. rest
ii) If he has played between 1 and 1/2 hours	1 hr. rest	45 min. rest
iii) If he has played for more than 1 1/2 hours	1 1/2 hr. rest	1 hr. rest
iv) If play has been interrupted for thirty (30) minutes or more because of rain or other warranted delay, the length of match time would be assessed		

## VII. THE COMPETITION

from the moment play resumes after the delay.

- v) If play is interrupted for less than thirty (30) minutes, match time would be considered continuous from the moment the first ball of the match was put into play.
  - e) Whenever it is necessary for a player to compete in two (2) singles matches in the same day, other than in exceptional circumstances a player shall be scheduled the following day no earlier than eighteen (18) hours from the start of his last match of the previous day, singles or doubles.
- 4) **Between Semi-final and Final**
- a) When the two (2) semi-final matches are not to be played consecutively, then the scheduled start time of the final shall be no earlier than eighteen (18) hours from the scheduled start time of the second semi-final match. In the case where the two (2) semi-final matches are to be played consecutively (i.e. "followed-by"), then the scheduled start time of the final shall be no earlier than twenty (20) hours from the scheduled start time of the first semi-final match.
  - b) Tournaments are encouraged to plan the schedule so that it exceeds the minimum requirement.
  - c) If rain or other unavoidable circumstances have caused a disruption in the schedule, then after considering the interests of the tournament, the players, the television and the public, the supervisor shall determine the revised time of the semi-final and/or the final.

### **Player Entitled to Minimum Rest**

**Case:** Because of rain delays, the singles semifinal and final matches are scheduled for Sunday. The two (2) semifinal singles matches are played on two (2) courts starting at 10 a.m. The final, because of television commitments, is scheduled to begin at 2 p.m. with live television coverage. One of the semifinal matches does not finish until 1:15 p.m. The tournament and the television staff still insist that the final match begin at 2 p.m. What is the solution?

**Decision:** The player is entitled to a minimum rest of 1 1/2 hours. The final cannot start before 2:45 p.m.

**Note:** In circumstances where television is a factor, the supervisor should try to give as much flexibility as possible by starting the semifinal matches as early as possible. Also, it is important to know the latest start time acceptable for television. The goal is to give the players more than their minimum rest time between a semifinal and final.

### **Rain: How Many Matches Per Player?**

**Case:** Rain has put the tournament behind schedule. Player A's singles match was suspended at one set all. Player A is also behind in the doubles. How many matches may player A be scheduled to play the next day?

**Decision:** Three (3). Completion of a match shall count as one (1) match. If the player wins the singles match in progress then he may be scheduled for one (1) more singles plus one (1) doubles. If he loses the first singles match, then he may be scheduled for two (2)

## VII. THE COMPETITION

doubles matches.

### **Scheduling Priorities**

**Case:** In preparing the schedule of play for Wednesday in a 32-draw outdoor event, the upper half of the draw is the half the tournament would like to play. Several players will have played singles on Monday and not again until Thursday if that half is played. Sections of the draw would have to be split to accommodate players not having two (2) days off between singles matches. What is the correct priority in scheduling?

**Decision:** Scheduling in outdoor events must keep sections of the draw together. Preferably, halves of the draw are scheduled together, if that is not possible then quarters are scheduled together. Players playing singles on Monday and Thursday should be avoided; however, halves of the draw should be kept together. Inclement weather can adversely affect the schedule as well as the fair treatment of the players unless these priorities are followed.

### **Rain Delayed Semifinal, When to Play Final?**

**Case:** Rain on Saturday prevents both semifinal singles from being played. The second semifinal is played on Sunday morning, with the winner due to play the final that afternoon. Can the winner of the second semifinal insist on a Monday final?

**Decision:** No. Every effort must be made to finish the tournament on Sunday. The winner of the second semifinal should be given the maximum amount of rest possible before playing the final. (ATP Policy)

### **Moving Indoors at an Outdoor event**

**Case:** Rain has disrupted play to the point where the event is in danger of not being completed. There are indoor courts available for use. May the supervisor move the matches indoors to complete this event?

**Decision:** Yes. Under the responsibilities of the supervisor it states that "the supervisor may, if necessary to eliminate the possibility of a player having to play two singles matches in one day, or if necessary to complete the event, move a match to another court, indoors or outdoors, regardless of surface". The exception to this is if the tournament director demonstrates to the supervisor that there will be a detrimental impact on the success of the tournament if singles or doubles matches are played indoors. In this case, the supervisor may elect to keep all matches for outdoor play. (ATP Policy)

## 7.22 On-Court Procedures and Requirements

### **A. Start of Tournament**

A tournament shall commence when the first serve of the first point of the first match is struck.

### **B. Start of Match**

A match shall commence when the first serve of the first point is struck.

## VII. THE COMPETITION

### C. Rules of Tennis

The Rules of Tennis shall apply to all ATP World Tour and ATP Challenger Tour tournaments except as amended by the ATP Official Rulebook.

### D. Appeal of Calls

#### 1) Questions of Fact.

- a) **Definition.** A question of fact is defined as an issue relating to what actually occurred on court during a specific match. Only the on-court officials shall determine questions of fact arising during a match and the player or the supervisor may not change such determinations.
- b) **Rule.** A player may not appeal the determination made by the on-court officials on a question of fact.

#### 2) Questions of Tennis Law.

- a) **Definition.** A question of tennis law is defined as an issue relating to the construction and application of specific facts to the ATP rules and regulations and the rules of tennis. During a match, the chair umpire shall first determine questions of tennis law. If the chair umpire is uncertain or if a player appeals the determination of the chair umpire, then the decision shall be made by the supervisor, which shall be final and non-appealable.
- b) **Player Rights.** A player shall have the right to appeal any ruling of tennis law in accordance with the following procedures:
  - i) When a player is of the opinion that a ruling by the chair umpire on a matter of tennis law is erroneous, he may appeal the ruling by notification to the chair umpire in a professional and non-abusive manner.
  - ii) The chair umpire shall stop play and immediately call for the supervisor. Upon the arrival of the supervisor, the chair umpire shall state the facts of the incident and the supervisor shall be bound by the facts as stated. The chair umpire shall then state his position with respect to the ruling. The supervisor shall review briefly the applicable rules with the player and the chair umpire and either affirm or reverse the ruling.
  - iii) Play shall be resumed upon the statement of "Let's Play" by the supervisor and the players must proceed to commence play and the twenty-five (25) second clock shall commence.

### E. Tennis Law - Cases

#### **Appeal of Judgment Calls**

**Case:** A first serve is hit down the middle and is called out and then corrected to good by the center service line umpire. The chair umpire awards the point to the server, but the receiver disagrees saying that he had a play on the ball. The chair umpire agrees and rules that the point be replayed. The supervisor is called to the court.

**Decision:** Point to server. The chair umpire may not change a judgment decision after a player appeal.

#### **Appeal of the "Facts": Receiver**

**Case:** First point of a game, the first serve is called fault and overruled by the chair umpire to good. The chair umpire then announces

## VII. THE COMPETITION

15-Love. The receiver states that the point should be re-played because he returned the ball into the court. The chair umpire realizes that the receiver did in fact return the ball and orders the point to be replayed. The server claims that the chair umpire cannot change his decision and asks for the supervisor to be called.

**Decision:** The point is re-played. The chair umpire's initial awarding of the point to the server was incorrect based upon the facts as described by the chair umpire: The receiver did return the serve.

#### **Appeal of the "Facts": Server**

**Case:** First point of a game, the first serve is called fault and overruled by the chair umpire to good. The chair umpire awards the point to the server based upon his judgment that the receiver did not have a play on the ball. The receiver claims that he could have played the ball. The chair umpire is not sure of his original judgment and orders the point to be re-played. The server claims that the chair umpire may not change his judgment based upon an appeal from the receiver and asks for the supervisor to be called.

**Decision:** Point to the server. The facts on which the chair umpire based his initial decision did not change. Therefore, the chair umpire may not change his original decision based upon a player's appeal or protest.

#### **Umpire Blocked on Question of Fact**

**Case:** Player A stops play claiming that player B had played the ball after it had bounced twice. The chair umpire said that he was "blocked" and could not make the decision.

**Decision:** The point stands as played. When the chair umpire has the primary responsibility for a call (nets, throughs, not-ups and touches) as opposed to the secondary responsibility (line calls), an immediate decision must be made. If the chair umpire did not see a rules violation on something for which he has the primary responsibility then technically no violation can be called

#### **Appealing for a Let**

**Case:** Player A serves and player B returns the ball for a winner. Player A appeals to the chair umpire that the service was a let. The chair umpire says that he did not hear a let. Player A then asks player B if he heard a let. Player B answers yes. Upon hearing this, the chair umpire says that since both players heard a let, we shall play a let. Player B objects saying that it is the chair umpire's call and that he was only confirming to player A that the chair umpire had made a mistake.

**Decision:** The point stands as played. The chair umpire cannot make assumptions as to the intent of player B's comment. The chair umpire should be certain that the intention of player B was to play a let before making any decision.

**F. Hindrance.** A hindrance may result (1) from a corrected call by an official or (2) from an inadvertent event that occurs on-court:

- 1) **Corrected Call.** Whenever there is a corrected call either by overrule, correction

## VII. THE COMPETITION

by a line umpire or otherwise, the chair umpire in his sole judgment must determine if either player was hindered, and if so, order a "Let" to be played.

- a) If a call is corrected from "Good Ball" to "Out," then the point is ended and there is no hindrance.
  - b) If the call is corrected from "Out" to "Good Ball," then there must be a "Let" played unless it was a clear ace or a clear winning shot that the player could not possibly have retrieved. If there is any reasonable possibility that such a ball could have been played, then the player who would have lost the point must be given the benefit of the doubt.
- 2) **Inadvertent or Deliberate event.** A distraction occurring on-court may be ruled inadvertent (unintentional) or ruled deliberate.
- a) Inadvertent distractions may include the following (a "Let" may be called in these cases): a ball rolling onto the court; a ball falling out of a pocket; a hat falling off; or an involuntary sound or exclamation (ex. verbal reaction to an injury) from a player. Any player who created the hindrance must be advised that the next time play is stopped by the chair umpire because of that player's similar actions; it shall result in a loss of point.
  - b) Any distraction caused by a player may be ruled deliberate and result in the loss of a point (intentional or unintentional). Deliberate is defined as the player meant to do what it was that caused the hindrance or distraction.
  - c) Care must be exercised to ensure rulings do not result in providing a player(s) with two opportunities to win a point.

### G. Hindrance Cases

#### **Corrected Call**

**Case:** A second serve is a "net" call. The service line umpire calls "out," then corrects it to "good."

**Decision:** Second serve

#### **Opponent's Gear Falls On The Court**

**Case:** A player's hat, towel, or a ball from his pocket falls to the court during play.

**Decision:** The chair umpire shall call a let and replay the point. He shall also inform the player that if the chair umpire makes a second call of let, it will result in a loss of point.

#### **Opponent Makes Noise**

**Case:** During play, a player thinking he has hit a winner, shouts "vamos", "come on", "yes", etc. as his opponent is in the act of hitting the ball..

**Decision:** If the chair umpire rules that a hindrance has occurred then, as the sound or exclamation that caused the hindrance was deliberate, the point shall be awarded.

#### **Inadvertent Hindrance**

**Case:** As a player is in the process of hitting a volley into the net, his hat falls off. He then claims a let for hindrance.

**Decision:** No let. A player may not hinder himself. A let should only be called when the opponent could have been hindered.

#### **Singles Stick Falls**

**Case:** After a first serve fault, the singles stick falls to the court.

## VII. THE COMPETITION

**Decision:** The chair umpire should award a first serve unless in his opinion the replacement time was such that the server was not delayed in his delivery of a second serve.

#### **Spectator Noise**

**Case:** During play an "out" call is made by a spectator. The player stops playing and claims hindrance.

**Decision:** The point stands as played.

#### **Early Foot Fault Call**

**Case:** The baseline umpire calls a foot fault on the server prior to him hitting a first serve. The server continues with his motion and hits the serve into the net.

**Decision:** First serve awarded. It is not a foot fault until the ball has been struck. Therefore, the call is erroneous and the line umpire has hindered the server.

### H. Overrule

- 1) The chair umpire may overrule a line umpire only if (1) there is a clear mistake by a line umpire, and (2) the overrule is made promptly after the mistake. A player may never appeal a determination on questions of fact to the supervisor.
  - a) **Clear Mistake.** As a matter of practice the chair umpire must be in a position to make a determination that a call was erroneous beyond a reasonable doubt. To overrule a ball called "Good" by the line umpire, the chair umpire must have been able to see a space between the ball and the line. To overrule an "Out" or "Fault" call by a line umpire, the chair umpire must have seen the ball hit on or inside the line. Clear foot-faults not called by the responsible line umpire should be called by the chair umpire.
  - b) **Promptly.** The chair umpire must overrule immediately after the line umpire makes the "clear mistake." The overrule "call" must be made almost simultaneously with the "clear mistake" made by the line umpire.
- 2) A player may request that the chair umpire verify a call or other determination of fact on a point-ending call made by an on-court official; upon such request the chair umpire shall immediately verify the same either by his own personal observation or upon confirmation of the line umpire or other on-court official involved. The chair umpire may never overrule the call of a line umpire upon the request of a player. A line umpire may never change a call as a result of a protest or appeal, except in the case of clay court ball mark procedures.
- 3) The request, verification and resumption of play should be completed within the twenty-five (25) seconds allowed between points. If the player prolongs the argument, the chair umpire should announce "Let's Play," and the player is subject to the provisions of the Code.

### I. Correction/Verification of Call

**Line umpires.** When a line umpire realizes that he/she has made an erroneous call, including an inadvertent sound, he/she should immediately call "Correction" so that the chair umpire and the players are aware of the error. The line umpire should then make the corrected call.

## VII. THE COMPETITION

### J. Ball Mark Inspection Procedures (Clay Courts)

#### 1) Chair Umpire

- a) A ball mark inspection requested by a player (team) shall be allowed only if the chair umpire cannot determine the call with surety on either a point-ending shot or when a player (team) stops playing the point during the rally (Returns are permitted but then the player must immediately stop). The chair umpire shall check ball marks if there is some doubt about the accuracy of the call.
- b) If the chair umpire sees a clear mistake, he may stop play with an overrule.
- c) The original call or overrule shall always stand if the line umpire and/or chair umpire cannot determine the location of the mark or if the mark is unreadable.
- d) Once the chair umpire has identified and ruled on a ball mark, this decision is final and not appealable.
- e) In clay court tennis, the chair umpire should not be too quick to announce the score unless absolutely certain of the call. If in doubt, the chair umpire should wait before calling the score to determine whether a ball mark inspection is necessary. Ball mark inspections made after the score has been announced or after first serves shall be done as quickly as possible so the server is not unreasonably delayed.
- f) In doubles, the appealing player must make his appeal in such a way that either both players stop playing the point or the chair umpire stops play. If an appeal is made to the chair umpire, then the chair umpire must first determine that the correct procedure was followed. If it is not proper or if it is late, then the chair umpire may determine that the opposing team was deliberately hindered.
- g) Players may not cross the net to check a ball mark without being subject to the Code. A player may not erase marks unless he is conceding the call or after a ball mark inspection occurs and the chair umpire has made a final decision.

#### 2) Line Umpires

- a) If a line umpire has to make a close call, he must keep his eyes on the mark and should not look at the chair umpire.
- b) If requested by the chair umpire, the line umpire shall walk directly to the mark and identify the mark to the chair umpire. The chair umpire shall then inspect the mark and make the determination.
- c) If directed by the chair umpire to identify a mark and the line umpire is not sure of the mark, the line umpire must state immediately to the chair umpire, "I do not have the mark."

### K. Clay Court Cases

#### **Can't Find Ball Mark**

**Case:** A line umpire calls a ball out on a clay court. The chair umpire asks him to show the mark. The line umpire cannot locate the mark and neither can the chair umpire.

**Decision:** The original (out) call must stand.

#### **Clay Court: Doubles Ball Mark Appeal**

**Case:** Player B returns a serve but his partner, player A, says, "wait" as he moves to look at the mark. The chair umpire stops play. The

## VII. THE COMPETITION

opponent, player C, appeals to the supervisor, saying player B returned the serve, which player C put away.

**Decision:** The procedure was correct (The chair umpire stopped play after an interruption by player A.) The mark is examined and if it is good, Team A-B loses the point; otherwise, it is a second serve.

**Must Both Players on a Team Stop to Get Ball Mark Inspection.**

**Case:** In doubles on a clay court, the second serve is called good. The receiver returns the ball but hesitates in search of the mark. His partner crosses (poaches) and hits the ball into the net. The receiver then appeals the second serve, stating that he stopped play prior to his reflex return.

**Decision:** The point stands as played. Both players must stop playing or the player appealing must do so in a manner that results in the chair umpire stopping play.

#### **Overrule Then Inspect Ball Mark**

**Case:** As a chair umpire, you overrule a ball on a clay court. The player disagrees and asks for a ball mark inspection. You think that maybe you made a mistake on the overrule.

**Decision:** The chair umpire should check the mark.

### L. Electronic Review

The use of an approved electronic system for reviewing line calls and/or overrules is authorized for use at ATP World Tour events. The protocol for its use is as follows:

- 1) A request for an electronic review of a line call by a player (team) shall be allowed only on either a point-ending shot or when a player (team) stops playing the point during a rally (returns are permitted but then the player must immediately stop).
- 2) In doubles the appealing player must make his appeal in such a way that either play stops or the chair umpire stops play. If an appeal is made to the chair umpire then he must first determine that the correct appeal procedure was followed. If it was not correct or if it was late, then the chair umpire may determine that the opposing team was deliberately hindered, in which case the appealing team loses the point.
- 3) Each player/team shall receive three (3) challenges per set (excluding the tie-break game). If the player/team is incorrect with a challenge, then one of the challenges is lost. If the player (team) is correct with a challenge, then the player retains his same number of challenges. Challenges remaining, if any, at the end of a set do not carry over to the next set.
- 4) During the tie-break game in any set, each player/team shall receive one (1) additional challenge. This is in addition to any challenges not lost, if any, during the set.
- 5) For doubles, the Match Tie Break shall be considered as a new set and each team shall receive three (3) challenges. Challenges remaining from the previous set do not carry over into the Match Tie Break. Successful challenges do not reduce the number of challenges that may remain.
- 6) To challenge a line call or overrule, the player must state clearly to the chair umpire his intent to challenge. The chair umpire will (a) reconfirm with the player his

## VII. THE COMPETITION

intent to challenge; (b) confirm that the player has challenges remaining; and (c) proceed with the electronic review.

- 7) The original call or overrule will always stand if the electronic review is unable, for whatever reason, to make a decision on that line call or overrule. In this case, the player shall not have his available number of challenges reduced.
- 8) If there is no call made from the on-court officials (unsighted line umpire and chair umpire cannot make the call) on a point ending shot, the chair umpire may call for a review and the result of the review will not affect the remaining challenges of either player.
- 9) The decision of the electronic review is final and cannot be appealed.
- 10) A certified official, approved by the ATP supervisor, shall act as the review official\* and his duties shall include, but are not limited to:
  - a) Determining which impact shall be reviewed by the system.
  - b) Act as the final authority on tracking the number of challenges each player has remaining.
  - c) Monitor the system to ensure that it is functioning properly.
  - d) Notify the chair umpire immediately in the case of a system failure or any other condition that prohibits or brings into question the ability of the system to review a challenged call. In this case, the chair umpire shall immediately notify both players that review is not available until further notice.

\* Review official and supporting technology staff shall be located within the stadium or arena in a secured area and with an unobstructed view of the court.
- 11) For each court that is using a review system, there shall be a minimum of one (1) video board, of sufficient size, located in a position where the chair umpire, players and spectators may view the results of the challenge.
- 12) Review Official Protocol is described in Exhibit X.

### M. Continuous Play/Delay of Game

Play shall be continuous, except that a maximum of twenty-five (25) seconds may elapse from the moment the ball goes out of play at the end of one point to the time the ball is struck for the next point. When a changeover ends, ninety (90) seconds may elapse. The procedures for enforcing this rule are as follows:

- 1) **25 Seconds/Continuous Play**
  - a) **Start Stop Watch.** The chair umpire must start the stopwatch after the ball goes out of play or when the players are ordered to play.
  - b) **Time Violation or Code Violation.** A Time or Code Violation must be assessed if the ball is not struck for the next point within the twenty-five (25) seconds allowed, except if the chair umpire extends the time for special circumstances defined by the ATP. There is no time warning prior to the expiration of the twenty-five (25) seconds.
  - c) A player may not receive back-to-back Time Violations because consecutive delays shall be penalized by a delay of game Code Violation, unless there has been a non-continuous game changeover.
- 2) **90 Seconds/Change-Over (Changing Ends)**
  - a) **Start Stop Watch.** The chair umpire must start the stopwatch the moment the ball goes out of play.

## VII. THE COMPETITION

- b) **“Time.”** The chair umpire must announce to players “Time” after one (1) minute has elapsed. If requested, prior to the match, by a television broadcaster, the chair umpire shall have the authority to delay the start of play until the end of the ninety (90) second changeover period.
  - c) **“15 Seconds.”** The chair umpire may announce to players “15 Seconds” if the players are still at their chairs and/or have not started toward their playing positions.
  - d) **Time Violation or Code Violation.** The chair umpire must assess a Time Violation or, when applicable, a Code Violation (after a medical time-out or treatment) if the ball is not struck for the next point within the ninety (90) seconds allowed, provided there has been no interference which prevented the Server from serving within that time or a delay by the chair umpire.
- 3) **120 Seconds/Set Break**
    - a) **Start Stop Watch.** The chair umpire must start the stopwatch the moment the ball goes out of play.
    - b) **“Time”.** The chair umpire must announce to players “time” after 90 seconds has elapsed. If requested, prior to the match, by a television broadcaster, the chair umpire shall have the authority to delay the start of play until the end of the one hundred twenty (120) second set break.
    - c) **“15 Seconds.”** The chair umpire may announce to players “15 Seconds” if the players are still at their chairs and/or have not started toward their playing positions.
    - d) **Time Violation or Code Violation.** The chair umpire must assess a Time Violation or, when applicable, a Code Violation (after a medical time-out or treatment) if the ball is not struck for the next point within the one hundred twenty (120) seconds allowed, provided there has been no interference which prevented the server from serving within that time or a delay by the chair umpire.
  - 4) **Not Playing to the Reasonable Pace of the Server**
    - a) **Start Stop Watch.** The chair umpire must start the stopwatch when the player is ordered to play or the moment the ball goes out of play.
    - b) **Time Violation or Code Violation.** The chair umpire must assess a Code Violation if the receiver is employing “gamesmanship.” The chair umpire must issue a Time Violation before the expiration of twenty-five (25) seconds if the receiver’s actions delay the reasonable pace of the server.
  - 5) **Stoppage and Postponement of a Match**
    - a) The chair umpire may stop a match temporarily because of or conditions of the grounds or weather. Any such stoppage by a chair umpire must be reported immediately to the supervisor. Once a match is stopped and until a match is postponed, the chair umpire must ensure that he, the players and all on-court officials remain ready to resume the match. The supervisor makes the decision to postpone a match until a later day.
    - b) Upon stoppage or postponement by the supervisor, the chair umpire shall record the time, point, game and set score, the name of the server, the side on which each player was situated and shall collect all balls in use for the match.
  - 6) **Warm up / Re-warm up.**

There shall be a five (5) minute warm-up before a match and in the case of a stopped or postponed match, the period of warm-up shall be as follows:

## VII. THE COMPETITION

- a) 0-15 minutes delay — No warm-up;
- b) more than 15 minutes but less than 30 minutes — Three (3) minutes of warm-up; and
- c) 30 or more minutes of delay — Five ((5) minutes of warm-up.

### N. Time and Equipment Cases

#### **Crowd Movement**

**Case:** The server is given a Time Violation for going beyond the 25 seconds that is allowed between points. The server claims that he should have been given additional time because there were some spectators taking their seats.

**Decision:** The Time Violation stands. The continuous play procedures shall be in effect regardless of spectator movement unless the chair umpire believes the movement is intended as a deliberate attempt to distract a player(s) or occurs in the designated lowest tier of seats.

#### **Ball Person as Personal Valet**

**Case:** A player receives a time violation from the chair umpire while waiting for the ball person to retrieve a towel. The player claims the ball person caused the delay.

**Decision:** The Time Violation stands. Toweling off between points with or without the help of a ball person is not a valid reason for delay.

#### **Time Violation, No Play, Results in Code**

**Case:** A player, upon hearing a Time Violation, comes to the chair umpire and asks "Why?" He receives an explanation followed by "Let's Play". The player continues his discussion and is given a Code Violation. The player appeals to the supervisor saying he should have received a Time Violation, Point Penalty.

**Decision:** The chair umpire suspends play and calls for the supervisor. Upon arrival, the supervisor affirms the decision of the chair umpire (two time violations are not given back-to-back unless there was a game changeover between them).

#### **Time Violation + 25 Seconds = Code**

**Case:** A player receives a time violation while standing at the back fence. He does not move to play and the chair umpire says, "Let's play". After another 25 seconds elapses, what does the chair umpire do?

**Decision:** A Code Violation is announced, (and possibly an inquiry, such as, "Are you OK?") followed by "Let's Play".

#### **Two Explanations are Enough**

**Case:** A player asks for an explanation and is given one. He then raises another point and receives another response. How long may this go on?

**Decision:** Normally only twice since continuous play provisions are not being complied with. After two brief responses, the chair umpire announces "Let's Play" and subsequently issues a Code Violation if the ball is not in play as a result of that player's action.

## VII. THE COMPETITION

#### **Changing Shoes**

**Case:** May a player receive extra time on a changeover in order to change his shoes and/or socks? If yes, how many times may he do so during the course of the match?

**Decision:** Yes. The chair umpire may allow a reasonable extension of the allotted changeover time in order for a player to change his shoes and/or socks. The player should not be allowed to leave the court in this instance. The player is limited to one change per match when extra time is granted unless the provisions for "equipment out of adjustment" take precedent. In that case, the chair umpire has the authority to decide each request on its own merit.

#### **Contact Lens**

**Case:** During a match, a player requests permission to leave the court in order to put in a contact lens.

**Decision:** The request to leave the court is denied. Contact lenses shall not be considered as equipment out of adjustment unless the player is wearing them at the time of the incident.

**Note** - Every attempt should be made to assist the player so that he may put the contact lenses in during the changeover.

#### **Time: Refusal to Play**

**Case:** After several close calls that go against him, a player comes to his chair on the changeover and says, "I'm not playing until the line umpire Crew is changed". After the chair umpire calls "Time", the player says, "I told you I'm not playing until the line umpires are changed". What should the chair umpire do?

**Decision:** The chair umpire should order the player to play and after 25 seconds use the Point Penalty Schedule.

#### **Re-Gripping Racquet**

**Case:** During a change of ends, while a player is re-taping the grip of his racquet, the chair umpire calls time. The player walks out to the baseline still taping the grip. At the end of the 90 seconds, the player has failed to commence his serve and is still working on the grip.

**Decision:** The chair umpire issues a Time Violation. The racquet is not equipment out of adjustment and therefore the player must serve within the allotted time. (Rules of Tennis, 29.) Similarly, adjusting the position of the strings or fixing string savers is not an excuse for delaying play.

#### **Replacing Shoes**

**Case:** During a match, a player requests permission to leave the court area to retrieve another pair of tennis shoes. He states that he is slipping and wants to get a pair of shoes with a different sole from his locker.

**Decision:** The request is denied. However, the chair umpire should use all possible means to have the shoes retrieved and brought to the court. This is not considered "Equipment Out of Adjustment". The shoes could have been brought to the court with the player and changed on-court; however, once he has the shoes, reasonable time is allowed for the change.



## VII. THE COMPETITION

### **Shoe Breaks**

**Case:** A player breaks his shoe and he needs to change, but his second pair is in the locker room.

**Decision:** The chair umpire should stop play and allow the player to get shoes.

### **No Play After 90 Seconds**

**Case:** A player is not ready to play after the ninety (90) second changeover (no injury involved).

**Decision:** A Time Violation is announced. "Let's Play" is normally added. The same applies if a player is not ready to play after the 120-second set break.

### **O. Toilet Break**

- 1) A player may be permitted to leave the court for a toilet break. A player is entitled to one (1) toilet break during a best of three set match and two (2) toilet breaks during a best of five set match. Toilet breaks should be taken on a set break and can be used for no other purpose.
  - a) For doubles, each team is entitled to a total of two (2) toilet breaks in all matches. If partners leave the court together, it counts as one (1) of the team's authorized breaks.
- 2) Any time a player leaves the court for a toilet break, it is considered one of the authorized breaks regardless of whether or not the opponent has left the court.
- 3) Any toilet break taken after the warm-up has started is considered one of the authorized breaks. Additional breaks will be authorized, but will be penalized in accordance with the Point Penalty Schedule if the player is not ready within the allowed time.

### **Toilet Visit**

**Case:** In a best of three (3) set match, a player has used his one toilet visit. The player informs the chair umpire that at the next changeover he would like to take another toilet visit prior to his serving.

**Decision:** The chair umpire may allow a player to leave the court but must inform the player that any delay beyond the 90 seconds will be penalized in accordance with the Point Penalty Schedule.

### **Toilet Visit: When Does Play Resume?**

**Case:** After play has been suspended for an authorized toilet visit, when does the "clock" start to resume play?

**Decision:** When the player returns to the court and has had the opportunity to retrieve his racquet, then the chair umpire should announce "Time". This announcement shall signal the players to resume the match.

### **P. Medical**

#### **1) Medical Condition**

A medical condition is a medical illness or a musculoskeletal injury that warrants medical evaluation and/or medical treatment by the physiotherapist during the warm-up or the match.

## VII. THE COMPETITION

### **a) Treatable Medical Conditions**

- i) **Acute medical condition:** the sudden development of a medical illness or musculoskeletal injury during the warm-up or the match that requires immediate medical attention.
- ii) **Non-acute medical condition:** a medical illness or musculoskeletal injury that develops or is aggravated during the warm-up or the match and requires medical attention at the changeover or set break.

### **b) Non-Treatable Medical Conditions**

- i) Any medical condition that cannot be treated appropriately, or that will not be improved by available medical treatment within the time allowed.
- ii) Any medical condition (inclusive of symptoms) that has not developed or has not been aggravated during the warm-up or the match.
- iii) General player fatigue.
- iv) Any medical condition requiring injections, intravenous infusions or oxygen, except for diabetes, for which prior medical certification has been obtained, and for which subcutaneous injections of insulin may be administered.

### **2) Medical Evaluation**

During the warm-up or the match, the player may request through the chair umpire for the physiotherapist to evaluate him during the next change over or set break. Only in the case that a player develops an acute medical condition that necessitates an immediate stop in play may the player request through the chair umpire for the physiotherapist to evaluate him immediately.

The purpose of the medical evaluation is to determine if the player has developed a treatable medical condition and, if so, to determine when medical treatment is warranted. Such evaluation should be performed within a reasonable length of time, balancing player safety on the one hand, and continuous play on the other. At the discretion of the physiotherapist, such evaluation may be performed in conjunction with the tournament Doctor, and may be performed off-court. \*

If the physiotherapist determines that the player has a non-treatable medical condition, then the player will be advised that no medical treatment will be allowed.

### **3) Medical Time-Out**

A medical time-out is allowed by the supervisor or chair umpire when the physiotherapist has evaluated the player and has determined that additional time for medical treatment is required. The medical time-out takes place during a change over or set break, unless the physiotherapist determines that the player has developed an acute medical condition that requires immediate medical treatment.

The medical time-out begins when the physiotherapist is ready to start treatment. At the discretion of the physiotherapist, treatment during a medical time-out may take place off-court, and may proceed in conjunction with the tournament Doctor.\*

The medical time-out is limited to three (3) minutes of treatment. However, at professional events with prize money of \$35,000 or less, the supervisor may extend the time allowed for treatment if necessary.

A player is allowed one (1) medical time-out for each distinct treatable medical condition. All clinical manifestations of heat illness shall be considered as one (1) treatable medical condition. All treatable musculoskeletal injuries that manifest as

## VII. THE COMPETITION

part of a kinetic chain continuum shall be considered as one (1) treatable medical condition.

A total of two (2) consecutive medical time-outs may be allowed by the supervisor or chair umpire for the special circumstance in which the physiotherapist/ Trainer determines that the player has developed at least two (2) distinct acute and treatable medical conditions. This may include: a medical illness in conjunction with a musculoskeletal injury; two or more acute and distinct musculoskeletal injuries. In such cases, the physiotherapist will perform a medical evaluation for the two or more treatable medical conditions during a single evaluation, and may then determine that two consecutive medical time-outs are required.

### 4) Muscle Cramping

A player may receive treatment for muscle cramping only during the time allotted for changeovers and/or set breaks. Players may not receive a medical time-out for muscle cramping. In cases where there is doubt about whether the player suffers from an acute medical condition, non-acute medical condition inclusive of muscle cramping, or non-treatable medical condition, the decision of the Physiotherapist, in conjunction with the tournament doctor, if appropriate, is final. There may be a total of two (2) full change of ends treatments for muscle cramping in a match, not necessarily consecutive.

**Note:** A player who has stopped play by claiming an acute medical condition, but is determined by the Physiotherapist and/or tournament doctor to have muscle cramping, shall be instructed by the Chair Umpire to resume play immediately.

If the player cannot continue playing due to severe muscle cramping, as determined by the Physiotherapist and/or tournament doctor, he may forfeit the point(s)/game(s) needed to get to a change of end or set-break in order to receive treatment.

If it is determined by the Chair Umpire or Supervisor that gamesmanship was involved, then a Code Violation for Unsportsmanlike Conduct could be issued.

### 5) Medical Treatment

A player may receive on-court medical treatment and/or supplies from the physiotherapist/Trainer and/or tournament Doctor during any changeover or set break. As a guideline, such medical treatment should be limited to two (2) changeovers/set breaks for each treatable medical condition, before or after a medical time-out, and need not be consecutive. Players may not receive medical treatment for non-treatable medical conditions.

### 6) Penalty

After completion of a medical time-out or medical treatment, any delay in resumption of play shall be penalized by Code Violations for Delay of Game.

Any player abuse of this medical rule will be subject to penalty in accordance with the Unsportsmanlike Conduct section of the Code of Conduct.

### 7) Bleeding

If a player is bleeding, the chair umpire must stop play as soon as possible, and the physiotherapist should be called to the court for evaluation and treatment. The physiotherapist, in conjunction with the tournament Doctor if appropriate, will

## VII. THE COMPETITION

evaluate the source of the bleeding, and will request a medical time-out for treatment if necessary.

If requested by the physiotherapist and/or tournament Doctor, the supervisor or chair umpire may allow up to a total of five (5) minutes to assure control of the bleeding.

If blood has spilled onto the court or its immediate vicinity, play must not resume until the blood spill has been cleaned appropriately.

### 8) Vomiting

If a player is vomiting, the chair umpire must stop play if vomiting has spilled onto the court, or if the player requests medical evaluation. If the player requests medical evaluation, then the physiotherapist should determine if the player has a treatable medical condition, and if so, whether the medical condition is acute or non-acute.

If vomiting has spilled onto the court, play must not resume until the vomit spill has been cleaned appropriately.

### 9) Physical Incapacity

During a match, if there is an emergency medical condition and the player involved is unable to make a request for a physiotherapist, the chair umpire shall immediately call for the physiotherapist and tournament Doctor to assist the player.

Either before or during a match, if a player is considered unable physically to compete, the physiotherapist and/or tournament Doctor should inform the supervisor and recommend that the player is ruled unable to compete in the match to be played, or retired from the match in progress. Additionally, if the supervisor, in consultation with the tournament Doctor, Physiotherapist, or a representative of the ATP Medical Advisory Board, determines that a player's participation in a tournament match may put the player at risk due to a life threatening or otherwise serious medical problem, the supervisor has the authority to rule a player ineligible to compete.

The supervisor shall use great discretion before taking this action and should base the decision on the best interests of professional tennis, as well as taking all medical advice and any other information into consideration.

When the supervisor has ruled a player ineligible to play due to circumstances involving a life threatening or otherwise serious medical condition, the player may return to play and be deemed eligible upon receipt by the ATP of a written statement from the player's personal physician concluding that the player's medical condition is sufficient to play in competition, and the supervisor, following consultation with the tournament Doctor and/or a representative of the ATP Medical Advisory Board (who may require that the player undergo additional testing and obtain a written statement clearing player to return to competition from a specialist physician), indicates that the player is eligible to play.

For retirements or withdrawals that are not deemed to be life threatening or otherwise serious medical condition, the player may subsequently compete in another event at the same tournament if the tournament Doctor determines that the player's condition has improved to the extent that the player may safely physically perform at an appropriate level of play, whether the same day or on a later day.

## VII. THE COMPETITION

- \* It is recognized that national laws or governmental or other binding regulations imposed upon the event by authorities outside its control may require more compulsory participation by the tournament Doctor in all decisions regarding diagnosis and treatment.

### Q. Medical Cases

#### **Delayed Medical Time-Out**

**Case:** A player has an accidental injury and asks to have a medical time-out during the next changeover. What procedure should be used for timing the treatment if the physiotherapist arrives?

**A.** 30 seconds into the changeover?

**B.** After 60 seconds has elapsed on the changeover?

**Decision A:** The physiotherapist has 3 1/2 minutes [but, as a minimum, he has three (3) minutes to treat after completing his diagnosis] to treat the player before the chair umpire announces "Time". The player then has 30 seconds to play, subject to the Point Penalty Schedule.

**Decision B:** The chair umpire stops the clock at 60 seconds and suspends play until the physiotherapist is ready to treat the player. The three-minute medical time-out begins, and after the chair umpire announces "Time", the player has 30 seconds to play or be subject to the Point Penalty Schedule.

#### **Equipment Out of Adjustment (Knee Brace)**

**Case:** During play, a player's knee brace becomes out of adjustment. The player requests time to repair his knee brace.

**Decision:** The player is allowed reasonable time to repair his knee brace without penalty. Any medical apparatus worn by a player shall be considered as equipment in regards to "Equipment Out of Adjustment".

#### **Exceeding 90 Seconds: Code Violation**

**Case:** If a player is receiving treatment by the physiotherapist on a 90-second change-over, and the treatment goes over the allowed 90 seconds, what happens?

**Decision:** When the chair umpire says "Time", the player must put the ball in play within 30 seconds. Any delay after that will result in a Code Violation.

#### **Medical Time-Out and Re-Warm-Up**

**Case:** If eight (8) minutes elapse before the physiotherapist arrives and treatment begins two (2) minutes later (the medical time-out begins) and is completed after another three (3) minutes, is a re-warm-up authorized?

**Decision:** No, a re-warm-up is not authorized.

#### **Medical Time-Out Request Honored?**

**Case:** A player asks for the physiotherapist. After examination, it is determined by the physiotherapist that the player is suffering from general fatigue that may not be improved by on-court medical treatment. What course of action should the chair umpire take?

**Decision:** The chair umpire announces, "Let's Play", after the

## VII. THE COMPETITION

physiotherapist completes his diagnosis. Delays will be penalized in accordance with the Point Penalty Schedule. The chair umpire has the option to issue a Code Violation for Unsportsmanlike Conduct in unusual cases.

#### **Medical Time-Out Starts When?**

**Case A:** When does a medical time-out begin?

**Decision A:** Medical time-out begins when the physiotherapist arrives and is ready and able to treat the player. Thus, the physiotherapist has completed his examination/diagnosis and the medical time-out starts when the physiotherapist begins treating the player.

**Case B:** A player asks to see the physiotherapist during the middle of a game although the chair umpire observed no accidental injury. What should the umpire do?

**Decision B:** First, tell the player that you will call the physiotherapist and he can see him at the changeover. If the player insists that he cannot continue, then stop play and call the physiotherapist. The physiotherapist will make the decision, upon examining the player, whether a medical time-out is needed.

#### **Only 90 Seconds to Re-Tape**

**Case:** A player turns his ankle, which is taped by the physiotherapist, and then on the next changeover wants the ankle re-taped.

**Decision:** The chair umpire may authorize the re-taping which must be completed within the 90-second changeover or the Point Penalty Schedule applies.

#### **Penalties After Medical Time-Out**

**Case:** When is the player penalized for going over three minutes on a medical time-out?

**Decision:** After the chair umpire says "Time"; the player must put the ball in play within 30 seconds. Any delay after that will result in a Code Violation. The player is allowed the time necessary to put on shoes, socks, ankle supports, etc.

#### **Re-Injury**

**Case:** A player injures his ankle and is granted a three (3) minute medical time-out by the physiotherapist. Five (5) games later, the player asks for another medical time-out claiming that he has re-injured the same ankle.

**Decision:** The chair umpire shall call for the physiotherapist who shall determine upon examination whether or not a three (3) minute medical time-out is authorized.

#### **Resuming Play After a Medical Time-Out**

**Case A:** After an injury and a four-minute suspension (by the chair umpire) for the arrival of the physiotherapist, the physiotherapist arrives and completes the treatment in one and 1/2 minutes. When does play resume?

**Decision A:** Immediately.

**Case B:** After a player becomes injured, the physiotherapist treats the player in two (2) minutes. When should play resume?

**Decision B:** Immediately when the player and physiotherapist are

## VII. THE COMPETITION

satisfied with the treatment administered, but the treatment is not to exceed three (3) minutes.

### **Tape Is Not “Equipment Adjustment”**

**Case:** During play, a player requests play to be suspended in order for him to adjust the tape on his ankle.

**Decision:** Play must continue. Taping is not considered as “Equipment Out of Adjustment”.

**Note:** The physiotherapist may be called to make adjustments during the 90-second changeover; however, any delays shall be penalized in accordance with the Point Penalty Schedule. If the player makes the adjustment without the help of the physiotherapist and violates the continuous play rule, then the player shall be penalized in accordance with the penalties set forth under “Unreasonable Delay”, i.e., Time Violation.

### **Treatment for Fatigue**

**Case:** May an physiotherapist put his hands on a player suffering from what appears to be fatigue?

**Decision:** Yes. The physiotherapist then makes the decision regarding a medical time-out.

### **Treatment: Within 90 Seconds**

**Case:** After an even game, a player asks to see the physiotherapist on the next changeover. The next game ends and 90 seconds elapse without the physiotherapist arriving on-court. The player asks that the changeover time be extended so that he may receive treatment. His rationale is that the physiotherapist’s arrival to the court is not the player’s fault.

**Decision:** The chair umpire suspends play until the physiotherapist examines the player and determines whether a medical Time-out is needed.

### **When to Take a Medical Time-Out?**

**Case:** What happens if a player is injured during a match and decides not to take his injury time-out right away? (Before the end of the next change-over)

**Decision:** A player may call for the physiotherapist at any time. The physiotherapist shall determine whether the medical time-out is to be authorized.

### **Chair Umpire Orders Medical Time-Out**

**Case:** A player has an accidental ankle injury and the chair umpire believes that continued play will result in non-professional play. May the chair umpire stop play (and call for the physiotherapist)?

**Decision:** Yes.

### **Singles Retirement: Still in Doubles?**

**Case:** A player retires from his singles match because of illness or medical reason. May he compete in the doubles competition?

**Decision:** If upon examination by the tournament Doctor after the retirement and again before the player’s scheduled doubles match, it is determined that the player’s condition has “improved” to the

## VII. THE COMPETITION

extent that he can compete at a professional level, then the player may continue in the doubles competition. If the player’s condition has not improved then he must not be allowed to compete in the doubles.

### **R. Miscellaneous Officiating Cases and Decisions**

#### **Broken String: First Service Fault**

**Case:** On a first service fault, the receiver breaks a string.

**Decision:** In Singles matches If the receiver changes his racquet, then a first serve will be awarded to the server. If the receiver elects not to change racquets, then the server must play a second serve.

In Doubles matches if the receiver changed the racquet with his partner the chair umpire should award a second serve unless in his opinion the replacement time was such that the server was delayed in his delivery of a serve.

#### **Broken String: First Service Let**

**Case:** The receiver breaks a string on a first service let.

**Decision:** The receiver must change racquets. A player is allowed to finish the point with a broken string but may not start a point with a broken string.

#### **Broken String: No Racquets**

**Case:** The player breaks a string in his last racquet.

**Decision:** The player is not allowed to continue with broken strings. The player is subjected to the penalties set forth in the Point Penalty System for Unreasonable Delay.

#### **Receiver Not Ready**

**Case:** The receiver is not ready but looks up as the second serve is hit, reflexes a return and says, “wait.”

**Decision:** Second serve. The server should observe that the receiver is ready. (If the chair umpire believes that gamesmanship is involved on the part of the receivers, then he may issue a code violation for Unsportsmanlike Conduct).

#### **Ball Hits Net Post Signage**

**Case:** The ball, while in play, hits the top of the ATP net signage and goes into the proper court.

**Decision:** ATP net signage will be considered permanent fixtures (other than the net, posts, singles sticks, cord or metal cable, strap or band) and will result in the loss of point.

#### **Invasion: Ball in Play**

**Case:** A player’s dampening device flies out of his racquet and touches the net or goes into his opponent’s court.

**Decision:** If the ball was still in play, the player loses point. The dampening device shall be considered a part of the racquet.

#### **Invasion: No Replay**

**Case:** After the point has been completed, player discovers opponent’s dampening device lying in his court. The player claims a point based on Rules of Tennis, rule 24.)

## VII. THE COMPETITION

**Decision:** The point stands as played. Since the chair umpire did not see the dampening device land in the opponent's court, he may not rule that an invasion occurred. Invasion occurs only when the ball is in play. Since the chair umpire did not know the timing of the incident, he may not assume that an invasion did occur.

### **Player Hits Net Pipe Support**

**Case:** A player touches a "pipe support" with his foot while the ball is in play.

**Decision:** In this case the "pipe support" is to be considered as part of the net; thus if a player touches it while the ball is in play, he loses the point.

### **Touching Net or Opponent's Court**

**Case:** If while the ball is in play a player's foot slides under the net but does not touch the net, should this still be considered a "touch" since the net should have extended fully to the court surface?

**Decision:** No. This cannot be considered a "touch" if the player did not actually touch the net. It is likely, however, that an invasion has occurred from the player's foot touching his opponent's court. If this did occur, then the chair umpire shall call an "invasion" and award the point to the player's opponent.

### **Ball Touches Net Pipe Support**

**Case:** The ball falls over the net and hits the "pipe support" used on indoor courts.

**Decision:** In this case, the "pipe support" is to be considered as part of the court; thus when the ball hit the pipe, it would be ruled as a first bounce.

### **Player Touches Net Outside of Singles Stick**

**Case:** A player runs for a drop shot and returns it into the opponent's court and then runs into net between net post and singles stick. What is the ruling?

**Decision:** Play continues. This part of the net is considered a permanent fixture.

### **Ball Rolls Onto Court**

**Case:** After a first service fault, a ball comes into the court from another court.

**Decision:** If the server has started his motion, then a first serve shall be awarded. In other cases, a second serve shall be played unless in the opinion of the chair umpire the delay was unusually long and unfairly disrupted the rhythm of the server.

### **Umpire Un sighted**

**Case:** A line umpire is unsighted and the chair umpire cannot make the decision.

**Decision:** The point is replayed, except in the case where it was discovered after the point had been completed that during a rally a line umpire had been unsighted. In that case, the point would stand as played.

## VII. THE COMPETITION

### **Intimidating Line Umpire**

**Case:** A serve is hit near the sideline and the receiver, hearing no call, immediately turns around and screams at the line umpire. The line umpire, who had signaled good, then calls and signals out.

**Decision:** The chair umpire rules the serve good based on the line umpire's original call. The supervisor, if called, upholds the chair umpire's decision based on an official not changing his call based on a player appeal.

**Note:** The chair umpire may have to ask for the line umpire's original call if he is uncertain or disregard the line umpire's call and make the call himself.

### **Service Order**

**Case:** In a doubles match, Team A serves out of order. After two points have been played, the chair umpire realizes the mistake.

**Decision:** The chair umpire should correct the mistake immediately.

### **Receiving Order**

**Case:** In a doubles match, the players on the team switched their receiving positions during the set. When this is realized, what action should the chair umpire take?

**Decision:** The original receiving positions of each player on that team must be taken after the completion of the game in progress. If error occurred during a tie break, then the receiving order shall remain as altered until the completion of the tie break game.

## 7.23 Line Umpire Requirement Positions and Calls

### **A. Number for Matches**

- 1) **Full Complement of Line Umpires.** If a chair umpire has a full complement of line umpires, then the assignments shall be as follows:
  - a) Base, side, center service and service line umpires call all "Outs" and "Faults" for their respective lines.
  - b) Net judge calls all "Nets" and "Throughs" (if designated by the chair umpire), measures the net height at the beginning of each set and administers the ball changes. A net device may be authorized for use.
  - c) Base, side and center service line umpires call "Foot Faults" on their respective lines.
  - d) Chair umpire calls all "Lets," "Foul Shots," "Foul Strokes," "Hindrances," "Not Ups" and "Touches."
  - e) Line umpires shall not be permitted to call through the net.
- 2) **Less than a Full Complement of Line Umpires.** If less than a full complement of line umpires is available, the following should be used (Sufficient line umpires must be assigned in the main draw so that the chair umpire is not solely responsible for calling any one line.):
  - a) **Seven (7) line umpires.** All long lines are called only up to the net. Serves are called from the receiver's end and the center line umpire returns to his assigned sideline after the serve is put into play, i.e., there is movement during the point. The assignments for seven (7) line umpire crew are as follows:
    - i) Four (4) side line umpires, one of who calls the receiver's center service

## VII. THE COMPETITION

line; after the serve is put into play, this umpire returns to his assigned side line. (The umpire calling the center service line on the receiver's end moves during the point when he returns to his assigned side line after the serve is put into play.). In addition, the side line umpire on the receiver's end shall alternate calling the center service line of the "deuce" and "advantage" courts, moving between points.

- ii) One line umpire calls serves at each end of the court.
  - iii) One line umpire calls each base line (2).
  - iv) Chair umpire calls all "Lets," "Not Ups," "Foul Shots," "Touches," "Hindrances" and "Throughs."
- b) **Six (6) Line Umpires.**
- i) Three (3) umpires cover the long lines; the side service lines are called through the net from the server's end of court and the center service line is called from the receiver's end.
    - aa) There is no movement during a point.
  - ii) One line umpire calls serves at each end of the court.
  - iii) One line umpire calls each base line (2).
  - iv) Chair umpire calls all "Lets," "Not Ups," "Foul Shots," "Touches," "Hindrances" and "Throughs."
- c) **Five (5) Line Umpires.** The assignments are the same as for the six (6) man crew, except that the center service line umpire shall move after the serve to the side line.
- d) **Four (4) Line Umpires.** The assignments are the same as for the five (5) man crew, except that the chair umpire, depending on personal preference and court surface, selects the lines that he will call.
- e) **Less Than Four (4) Line Umpires.** The chair umpire shall assign the line umpires to the best advantage possible.
- f) **Umpiring Without Line Umpires.** If a chair umpire is required to umpire a match without any line umpires, or without a full complement of line umpires, then the chair umpire must make the calls for the net and all unattended lines. If the chair umpire is unable to give a decision on a call or other questions of fact, then he must order a "Let" to be played.

### **Players Don't Call Lines**

*Case: In ATP World Tour or ATP Challenger Tour qualifying events where approval has been granted to use less than five (5) line umpires per match; may the chair umpire designate certain or all lines for the players to make the calls?*

**Decision:** No. If a chair umpire is required to umpire a match without any line umpires or without a full complement of line umpires, then the chair umpire must make the calls for the net and all unattended lines.

### **B. Hand Signals of Line Umpires**

The approved hand signals are as follows:

- 1) **"Out" or "Fault."** The arm should be fully extended sideways at shoulder height, pointing in the direction in which the ball has fallen, palm of the hand facing the chair umpire, fingers extended and joined. If the ball falls out of the court to the left or the right, the left or right arm as the case may be is extended after the verbal call of "Out" or "Fault" (as applicable) is made. The hand signal is in addition to

## VII. THE COMPETITION

and is secondary to the verbal call of "Out" or "Fault"; the hand signal must never be used instead of the verbal call.

- 2) **"Good Ball."** The hands shall be pointed down with palms down and fingers extended together. There is no verbal call for a good ball. The hand signal is used in silence and only when necessary to verify that a close ball was good.
- 3) **"Un sighted."** The hands are placed beneath the eyes facing in the direction of the chair umpire but not affecting the vision of the line umpire. The hand signal verifies that a line umpire is unable to call a ball because of his vision being obscured. There is no verbal call for a line umpire being unsighted and the hand signal is used in silence.
- 4) **"Net."** The arm is fully extended upwards at the same time the verbal call "Net" is made.

### **7.24 Scoring of Match**

#### **A. Manual**

The chair umpire shall mark his scorecard in accordance with the following:

- 1) **Pre-Match.** Before the pre-match meeting with the players, ensure the completion of the information requested on the scorecard such as name of tournament, round, players' names, etc.
- 2) **Toss.** After the "toss," note who won the toss, their election, etc.
- 3) **Warm-Up.** Note the time that the warm-up begins.
- 4) **Time.** Note the time play begins and concludes in each set.
- 5) **Sides For Serve.** Note the initials of each player in the order of their serves and also on the side of the scorecard corresponding to their proper sides of the court.
- 6) **Ball Change.** Mark in advance the game for which a ball change will be made on the left side of the scorecard.
- 7) **Points.** Points should be made by slanted marks in the boxes on the scorecard and/or by the following code:
  - "A" - Ace
  - "D" - Double Fault
  - "C" - Code Violation
  - "T" - Time Violation
  - "." - First Service Fault (a dot shall be made in the middle of the bottom line of the Server's box).
- 8) **Games.** Games may be marked by either of the following methods:
  - a) **Method A.** The cumulative total of games won by each player is set out in the "Games" column at the end of each game; and
  - b) **Method B.** The cumulative total of games won by the winner of each game only is set out in the "Games" column at the end of each game.

#### **B. Handheld Device**

Instructions will be provided on-site at ATP World Tour tournaments for the operation of the handheld scoring device.

## VII. THE COMPETITION

### C. Point Penalty Card

The chair umpire must mark his Point Penalty Card in accordance with the following:

- 1) **Post-Match.** If a Code Violation, Time Violation or Post Match incident occurs, complete the information requested on the Point Penalty Card, such as name of tournament and a summary of the incident.
- 2) **Rules Violation.** The violation should be checked and the Code section noted for each violation.
- 3) **Statement of Facts.** A contemporaneous statement should be made of all the facts (who, what, when, where and why) of the violation quoting verbatim any statements made that are considered to be obscene or abusive.

### 7.25 Announcing

#### A. Calls of On-Court Officials

The verbal calls of the on-court officials shall be made loudly and clearly in English and any other appropriate language as follows:

- 1) **“Fault.”** If either the first or second service fails.
- 2) **“Out.”** If a return hits the ground, a permanent fixture or another object outside the court.
- 3) **“Net”** If a service hits the top of the net.
- 4) **“Footfault”** If a player violates rule 7 or 8 of the Rules of Tennis.
- 5) **“Let.”** If the chair umpire determines that a point should be replayed.
- 6) **“Not Up.”** If a player fails to hit a ball in play on the first bounce.
- 7) **“Foul Shot” or “Touch.”** If a ball is intentionally struck twice, or touched before it comes over the net, or while volleying, the ball hits the court after leaving the racquet before going over the net, or a player touches the net while the ball is in play, or a ball in play touches a player, or anything that he wears or carries falls into the opponent’s court or touches the net.
- 8) **“Hindrance.”** If a player deliberately or involuntarily commits an act which hinders his opponent in making a stroke.
- 9) **“Through.”** If a ball goes through the net.
- 10) **“Wait Please.”** To preclude starting play when a hazard or other circumstance makes it appropriate to delay the beginning of a point. Do not make this call if a player’s arm is in motion to strike the ball (call “Let” immediately after the serve is struck).
- 11) **Overrule.** Make the following announcement:
  - a) **“Correction, the ball was in;”** or
  - b) **“Out” or “Fault.”**

#### B. Code and Time Violations

The following are examples of Code of Conduct announcements to be used:

## VII. THE COMPETITION

- 1) Point Penalties assessed for violation of the Code should be announced in accordance with the following examples:

“Code Violation, Delay of Game, Warning, Mr.\_\_\_\_(last name).”

“Code Violation, Verbal Abuse, Point Penalty, Mr.\_\_\_\_(last name).” “Let’s play” (“Let’s Play” is optional).

“Code Violation, Verbal Abuse, Game Penalty, Mr.\_\_\_\_(last name).”

If instructed by the supervisor, the announcement for a default shall be, for example:

“Code Violation, Unsportsmanlike Conduct, Default, Mr.\_\_\_\_(last name).”

- 2) Time Violations resulting from non-compliance with the Unreasonable Delay provisions of the Code shall be announced in accordance with the following examples:

“Time Violation, Warning, Mr.\_\_\_\_(last name).” (“Let’s Play” is optional. Consecutive delays will be penalized by a Delay of Game Code Violation, unless there has been a non-continuous game change-over.)

Subsequent Delays:

“Time Violation, Point Penalty, Mr.\_\_\_\_(last name).”(“Let’s Play” is optional.)

- 3) After a point or game penalty, the new score is announced.
- 4) If a chair umpire wants the supervisor to assess an immediate default, he is to announce “Code Violation, supervisor to the court.”
- 5) A player cannot appeal to the chair umpire for the withdrawal of a “Time Violation” or “Code Violation” given to his opponent.
- 6) Code Violations shall be announced in English.

#### C. Language - Chair Umpire

Chair umpires should announce matches in the language of the tournament and subsequently in English. Conversations between the chair umpire and player may be in any language; however, if the language used is not English, then the chair umpire must be prepared to advise the other player of the nature of the discussion.

#### D. Medical Time-Out

The following are examples of announcements to be made when there is a medical time-out:

When the chair umpire decides to call for the physiotherapist, the chair umpire shall announce:

“The physiotherapist has been called to the court.”

After a three (3) minute time-out is authorized, the chair umpire should make the public announcement of:

“Mr.\_\_\_\_\_is now receiving a medical time-out.”

The following announcements are to be made privately to the physiotherapist and both players/teams:

## VII. THE COMPETITION

“Two (2) minutes remaining”

“One (1) minute remaining”

“Thirty (30) seconds remaining”

“Treatment complete”

“Time” (public)

Once the “Treatment complete” notice has been given to the physiotherapist and both players/teams, then if needed, the player should be given the time necessary to put on socks and shoes before “Time” is called.

If there is no play after an additional thirty (30) seconds, the delay is penalized in accordance with the Point Penalty Schedule.

### E. Player Introductions

The following are examples of announcing statements to be used for player introductions:

- 1) If the introduction of players is to be made from the chair, then during the warm-up, the chair umpire says: “This is a \_\_\_round singles/doubles match, best of three (3) tie-break sets. To the right of the chair \_\_\_\_\_(full name) and to the left of the chair \_\_\_\_\_(full name).\_\_\_\_\_ (full name) won the toss and elected to \_\_\_\_\_.”
- 2) If the introduction of players is made by a tournament announcer, then before each player’s first service game the chair umpire says: “\_\_\_\_\_ (full name) to serve.” (optional - “first set”).

### F. Score

The following are examples of announcing statements to be used for scoring:

- 1) The Server’s score is always called first, except in the Tie-break.
- 2) The score is announced: Fifteen-Love, Love-Fifteen, Thirty-Love, Love-Thirty, Forty-Love, Love-Forty, Fifteen-All, Fifteen-Thirty, Thirty-Fifteen, Fifteen-Forty, Forty-Fifteen, Thirty-All, Thirty-Forty, Forty-Thirty, Deuce (never Forty-All), Advantage \_\_\_\_\_(last name), Game \_\_\_\_\_(last name). For No-Ad scoring, when the score reaches deuce, the chair should announce: “Deuce, Deciding Point, Receiver’s Choice.”
- 3) The score must be announced loudly and distinctly when a point is finished for the players and the crowd. The chair umpire has the option to make the announcement either before or after the applause, whichever guarantees the announcement can be heard by the players. “Timing” for the next point begins when the point ends, not when the announcement is made.
- 4) At the end of a game or set the chair umpire, in addition to announcing “Game \_\_\_\_\_(last name),” should announce the score in games in conformity with the following example:  
“Game Smith, Jones/Smith lead 4 games to 2 (or 4-2)” or Game Smith, 3 games all.”  
“Game and third set, Smith, 7 games to 5. Jones leads 2 sets to 1.”

## VII. THE COMPETITION

If there is a scoreboard visible to the spectators, then the set number need not be mentioned. In such case only the score in games should be announced: “Game Smith, first game.”

- 5) When a set reaches the Tie-break, the chair umpire announces:  
“Game Smith, 6 games all. Tie-break.”
- 6) During the Tie-break, the score is announced by first giving the score and then the name of the player(s) leading, e.g.:  
“1-0, Jones” or “1-0, Jones/Smith” (Use “Zero” rather than “Love” in the Tie-break.)  
“1 All”  
“2-1, Smith”  
At the conclusion of the Tie-break, the chair umpire announces:  
“Game and \_\_\_\_\_ set, \_\_\_\_\_ (last name), 7 games to 6 (or 7-6).”
- 7) At the conclusion of the match, the chair umpire announces the winner in conformity with the following example:  
“Game, set and match Smith (optional -3 sets to 2); 3-6, 5-7, 7-5, 6-1, 6-3.”  
In each set, call first the number of games won by the winner of the match.
- 8) During the warm-up, the following examples of announcing statements should be used at the appropriate times:  
“Two (2) minutes” - 2 minutes until warm-up ends.  
“One (1) minute” - 1 minute until warm-up ends.  
“Time” (optional - “prepare to play”)- end of warm-up; direct balls to Server’s end of court.  
“\_\_\_\_\_” (full name), (optional - “first set”), to Serve, Play” - immediately prior to Server preparing to serve.



## **VIII. THE CODE**

### **8.01 Tournament Obligations**

#### **A. Application Requirements**

Each tournament agrees to comply with all provisions contained in the ATP World Tour Tournament Application where applicable.

#### **B. Conduct Contrary to the Integrity of the Game**

The favorable reputation of the ATP, its tournaments and players is a valuable asset and creates tangible benefits for all ATP members. Accordingly, it is an obligation for ATP World Tour or ATP Challenger Tour tournaments, owner(s), promoter(s), operator(s) or representative(s) thereof, to refrain from engaging in conduct contrary to the integrity of the game of tennis. Conduct contrary to the integrity of the game shall include, but not be limited to, comments to the news media that unreasonably attack or disparage a tournament, sponsor, player, official or the ATP. Responsible expressions of legitimate disagreement with the ATP policies are not prohibited. However, public comments that one of the stated persons above knows, or should reasonably know, will harm the reputation or financial best interests of a tournament, player, sponsor, official or the ATP are expressly covered by this section.

Violation of this section shall subject a tournament to a fine up to \$100,000, and/or loss or change in membership status, and/or forfeiture of all sums, if any, previously paid to the ATP.

#### **C. Ranking Based Entry**

Each tournament agrees to accept entries of tennis players on the basis of the South African Airways ATP Rankings (singles) and the ATP Doubles Rankings.

#### **D. Other Circuit**

Each ATP World Tour tournament and ATP Challenger Tour tournament agrees to refrain from being advertised or promoted as part of any other circuit or series of tournaments, unless expressly authorized by the ATP.

#### **E. Promotional Fees**

- 1) ATP World Tour 500, ATP World Tour 250 tournaments and World Team Championship have the option to offer fees for promotional services. No other ATP World Tour or ATP Challenger Tour tournament owner, operator, sponsor or agent is permitted to offer, give or pay money or anything of value, nor shall the tournament permit any other person or entity to offer, give or pay money or anything of value to a player, directly or indirectly, to influence or assure a player's competing in a tournament, other than prize money, unless authorized to do so by the ATP.
- 2) In the event the President or Executive Vice President - Rules & Competition believes that a tournament may be violating this section, then upon demand, the tournament must furnish to the Executive Vice President - Rules & Competition or his agent access to and copies of all records to which it has access relating to such alleged prohibited compensation or, in the absence of such records, an affi-

## VIII. THE CODE

davit setting forth the facts in detail with respect to any transaction under question by the Executive Vice President - Rules & Competition. In the event a tournament fails to provide such records or affidavit for such audit, it may be subject to a fine up to \$50,000 and termination of membership, pending compliance with such demand.

- 3) Violation of this section shall subject the tournament to a fine up to \$50,000 plus the amount or value of any such compensation, and termination of membership, and/or forfeiture of all sums, if any, previously paid to the ATP.

### F. Security at Tournaments

Each tournament has the responsibility to provide security at the tournament site. Players have the responsibility to report any threat or unusual occurrence to the tournament director.

### G. Tournament Report

Each ATP World Tour tournament shall submit to the ATP a report of the tournament and its affairs as requested by the ATP.

### H. Wagers and On-Site Tennis Betting

- 1) No ATP World Tour or ATP Challenger Tour tournament, ATP member or any person who directly or indirectly has a controlling ownership interest therein or who is the Designated Representative (as defined in the ATP By-Laws) or tournament director or other employee or agent of an ATP World Tour or ATP Challenger Tour tournament or ATP member (excluding employees or agents who do not have executive or material management authority) shall engage in any form of gambling or wagering in connection with any ATP World Tour or ATP Challenger Tour tournament.
- 2) On-Site Tennis Betting. No ATP World Tour or ATP Challenger Tour tournament shall, directly or indirectly, solicit or facilitate any person to wager on tennis matches while at the tournament site. Allowing betting companies, directly or through a third party, to accept any tennis wagers (electronically or otherwise) at the tournament site or any tournament related event is prohibited.

### I. Wild Cards

No ATP World Tour or ATP Challenger Tour tournament, or any person who directly or indirectly has a controlling ownership interest therein or who is the Designated Representative (as defined in the ATP By-Laws) or tournament director or other employee or agent of an ATP World Tour or ATP Challenger Tour tournament shall directly or indirectly, accept compensation in exchange for a wild card.

## 8.02 Tournament Violations

No ATP World Tour or ATP Challenger Tour tournament shall violate any provision of the ATP's rules and regulations. Violation shall subject the tournament to a fine up to \$100,000, plus any additional financial penalties specified in other rules, and/or change in membership status, and/or forfeiture of all sums, if any, previously paid to the ATP.

## VIII. THE CODE

### A. Investigation, Determination, Imposition and Review

- 1) The Executive Vice President - Rules & Competition shall investigate all facts concerning any alleged tournament violation of an ATP rule or regulation and shall provide written notice of such investigation to the tournament involved. The tournament shall be given at least five (5) days (excluding weekends) to provide to the Executive Vice President - Rules & Competition, directly or through counsel, such evidence as the tournament deems to be relevant to the investigation. The Executive Vice President - Rules & Competition shall conduct the investigation in consultation with the applicable ATP Regional CEO.
- 2) Upon the completion of his investigation, the Executive Vice President - Rules & Competition shall determine the innocence or guilt of the tournament involved and, in the latter case, shall state in writing the facts as found by him, his conclusions and the penalty to be imposed on the tournament. A copy of the decision of the Executive Vice President - Rules & Competition shall be promptly delivered to the tournament with copies to the President and the applicable ATP Regional CEO.
- 3) All fines shall be paid by the tournament by delivery to the Executive Vice President - Rules & Competition within twenty-one (21) days after receipt of written notice.
- 4) Any tournament found to have violated an ATP rule or regulation that results in a fine, may, after paying all fines, petition the President for discretionary review. This petition shall be in writing and must be filed with the President or Executive Vice President - Rules & Competition within twenty-one (21) days after notice of the determination and penalty is received by the tournament. (The Executive Vice President - Rules & Competition shall forward the review petition promptly to the President). Such petition shall state in detail the basis for the appeal. Within twenty-one (21) days after receipt of the petition, the President or his designee shall determine whether the appeal should proceed to a hearing or if a determination based upon the facts as presented is appropriate. If the President or his designee determines that the appeal should not proceed to a hearing, then the decision, upon notice to the tournament, becomes final. This decision may affirm, reverse or modify the decision of the Executive Vice President - Rules and Competition. If the President or his designee determines that the appeal should proceed to a hearing, he shall designate a date, time and place for the hearing of the appeal, and the President or his designee shall notify the tournament and the Executive Vice President - Rules & Competition. At the hearing, the tournament and the Executive Vice President - Rules & Competition shall present to the President or his designee, their respective positions on the facts. On the appeal, the President or his designee may affirm, reverse or modify the decision of the Executive Vice President - Rules & Competition. If the appeal is decided against the tournament, then the President or his designee shall charge to the tournament the reasonable costs of the appeal, which shall include, but not be limited to, the reasonable travel and living expenses incurred by all witnesses.
- 5) If the penalty imposed on the tournament includes a recommendation other than a fine, including a recommendation for loss or change in tournament membership status, that recommendation shall be reviewed by the ATP Board, which may implement, modify or reject the recommendation of the Executive Vice President

## VIII. THE CODE

- Rules & Competition. The imposition of any non-fine penalty by the ATP Board shall be made in accordance with the By-laws.

- 6) Service of any document on a tournament as is required by this section shall be deemed completed if mailed to the tournament director at the address indicated in the tournament application or as subsequently revised by the tournament member. Any written communication to be sent to the ATP President or Executive Vice President - Rules & Competition should be addressed as follows, unless notice of change is subsequently published.

ATP President	<b>OR</b>	EVP - Rules & Competition
IG House		ATP Americas
Paliser Road		201 ATP Blvd
London W14 9EB		Ponte Vedra Beach, FL 32082, USA
Telephone: +44 207 381 7890		Telephone: +1 904 285 8000
Facsimilie: +44 207 381 7895		Facsimilie: +1 904 779 3300

- 7) The ATP is authorized to obtain collection of all overdue fines along with costs, if any, by all reasonable means, including legal proceedings as may be deemed necessary and appropriate.

### 8.03 Player Code of Conduct (“Code”)

#### A. Entry/Withdrawal Offenses

- 1) **Entry Obligations.** No player or team entered into the main draw or moved into the main draw as a direct acceptance of a tournament may withdraw after the entry and withdrawal deadline or not appear for first-round match(es) without penalty as described below. The Executive Vice President, Rules & Competition shall make such investigation as is reasonable to determine the facts regarding any such entry offense and, upon determining that a violation has occurred, shall specify the fine.

#### B. Fines

##### 1) ATP World Tour Tournaments

- a) The provisions relating to assessment and payment of withdrawal, late withdrawal or punctuality fines for tournaments are separate from but in addition to the provisions of the player ATP commitment. The penalties are:

## VIII. THE CODE

### i) Singles

- aa) **ATP World Tour 250 Only.** Withdrawals occurring prior to the 12 noon, Eastern time, USA, Friday withdrawal deadline

#### South African Airways ATP Rankings (Singles)

<u>(most recent)</u>	<u>Third (3rd) Offense</u>	<u>Fourth (4th) Offense</u>	<u>Fifth (5th) and Subsequent Offenses</u>
1 - 10	\$10,000	\$20,000	\$40,000
11 - 25	\$5,000	\$10,000	\$20,000
26 - 50	\$2,000	\$4,000	\$8,000
51-100	\$1,000	\$2,000	\$4,000
101 +	\$500	\$1,000	\$2,000

- bb) **ATP World Tour Masters 1000, ATP World Tour 500 & 250 events.** Withdrawals occurring after the 12 Noon, Eastern Time, USA, Friday withdrawal deadline (Late Withdrawals):

#### South African Airways ATP Rankings (Singles)

<u>(most recent)</u>	<u>First (1st) Offense</u>	<u>Second (2nd) Offense</u>	<u>Third (3rd)* and Subsequent Offenses</u>
1 - 10	\$20,000	\$40,000	\$80,000
11 - 25	\$10,000	\$20,000	\$40,000
26 - 50	\$4,000	\$8,000	\$16,000
51-100	\$2,000	\$4,000	\$8,000
101 +	\$1,000	\$2,000	\$4,000

\*For purposes of determining 2nd, 3rd and Subsequent Offenses, only Late Withdrawals are counted.

- ii) **Doubles.** The fine for withdrawal and/or violation of the punctuality rule is \$1,000 (doubled if seeded).

**Note:** If the withdrawal was due to one or both members of the team being accepted into the main draw singles of another event, then neither player is subject to a fine.

- b) Fines shall be doubled in the case of any player who would have been seeded, based on the most recent South African Airways ATP Rankings (singles).  
c) Third and subsequent withdrawals from the qualifying competition at an ATP World Tour Masters 1000 or ATP World Tour 500 tournament will be fined \$250 or \$500 if he would have been seeded based upon the most recent South African Airways ATP Rankings (singles). If the player withdraws after

## VIII. THE CODE

the 12 noon Eastern time, USA, Friday deadline, or is a No Show, it is a Late Withdrawal and the fine shall be \$1,000 (or \$2,000 if seeded).

- d) In circumstances that are flagrant and particularly injurious to the success of a tournament, or are singularly egregious, a single violation of this section shall also constitute the player Major Offense of Aggravated Behavior.

### 2) ATP Challenger Tour Tournaments

- a) The penalty for third and subsequent withdrawals is a fine of \$250 for each offense and applies to singles and doubles. Fines shall be doubled in the case of any player who would have been seeded, based on the most recent South African Airways ATP Rankings (singles).
- b) Any singles withdrawal occurring after 12 noon, Eastern Time, USA on Friday, shall be assessed a fine of \$1,000 (or \$2,000 if seeded). For doubles, after the doubles draw has been made, all non-medical withdrawals will be subject to a fine of \$500 (or \$1,000 if seeded).

### C. Tournament Rebates

Tournaments shall receive a rebate from the ATP when the following conditions have occurred:

- 1) **ATP World Tour Masters 1000.** All fine amounts collected as a result of late withdrawals shall be returned to the tournament where the late withdrawal occurred.
- 2) **ATP World Tour 500.** All fine amounts collected as a result of late withdrawals shall be returned to the tournament where the late withdrawal occurred. In addition, tournaments who do not attract a player field that meets the “field expectation” for their particular category will receive a payment from the ATP. Field expectation and rebate structure is defined in Exhibit Y of this rule book, “ATP World Tour 500 Field Expectation Protocol”.
- 3) **ATP World Tour 250.** All fine amounts collected as a result of withdrawals or late withdrawals shall be returned to the tournament where the withdrawal or late withdrawal occurred.

### D. Withdrawal Penalties

- 1) **ATP World Tour 500.** Any player withdrawing after the entry/withdrawal deadline shall have a ranking penalty assessed in accordance with procedures specified in the ranking section of this rule book. Players shall not have the ranking penalty assessed if they complete the requirements for “promotional activities”; are out of competition for 30 days; or the withdrawal complied with the requirements for an on-site withdrawal. Players may appeal withdrawal penalties to a Tribunal who will determine whether the penalties are affirmed or set aside.
- 2) **ATP World Tour Masters 1000.** Any player withdrawing from the main draw shall be suspended from a subsequent ATP World Tour Masters 1000 event. This event shall be the event where the player earned the highest point total during the previous 12 months. Subsequent withdrawals will carry a second suspension from the next event where the player earned his second highest point total. Additional withdrawals will include further suspensions in the same manner. Players shall not have the suspension penalty assessed if they complete the requirements for “promotional activities” or the withdrawal complied with the requirements for an

## VIII. THE CODE

on-site withdrawal. Players may appeal suspension penalties to a Tribunal who will determine whether the penalties are affirmed or set aside (see sections J & K).

### E. Retirement or Withdrawal Penalty (On-Site)

- 1) A player who, because of injury or illness, retires during a match or withdraws during the tournament week must submit to an on-site medical examination by the designated tournament doctor. Any player who retires during a match must be examined by the tournament doctor prior to the end of play on the day of the retirement. Failure to submit to such examination shall be a violation of this section and shall subject a player to a fine at ATP World Tour tournaments of \$10,000 (\$2,500 for the qualifying competition) or at ATP Challenger Tour tournaments to a fine of \$1,000, (\$500 for the qualifying competition), or the amount of prize money won at the tournament, whichever is greater.
- 2) Following any on-site retirement or withdrawal, the supervisor at the next tournament in which the players wants to play, may require the player to submit to an on-site examination by the designated tournament doctor and receive authorization from the supervisor before competing in any future ATP World Tour and ATP Challenger Tour tournaments. The supervisor’s authorization shall be based on the following: the results of the on-site medical examination; a review of such results with one of the ATP’s medical services directors, if possible; and any other appropriate information.
- 3) Should a doubles match in an ATP World Tour or ATP Challenger Tour event be uncontested or fail to be completed, the losing team shall only receive points and prize money from the previous round unless one of the following is applicable:
- a) Neither player was in the singles main draw.
- b) The retiring/withdrawing player is still in the singles competition and at the time of the medical examination is declared unfit to play in the singles of that event or, if no longer involved in the singles competition of that event, is forced to withdraw from the singles or doubles\* of the next tournament in which he is entered.
- \*For ATP Challenger events the withdrawal for doubles must be after the withdrawal deadline.
- c) The withdrawing player had retired/withdrawn from his singles match, which was scheduled the same day.
- i) A team withdrawing from the first round will not receive prize money even if there is not an alternate team.

#### **No Medical? Big Mistake**

**Case:** A player retires from his singles match and leaves the tournament site without having been examined by the tournament doctor. Later, it is discovered that the player has left the tournament city. What action does the supervisor take?

**Decision:** Any player who fails to submit to an on-site examination by the tournament doctor after retiring from a match shall be subjected to a fine of \$10,000 (\$1,000 for ATP Challenger Tour tournaments) or the amount of prize money won at the tournament, whichever is greater.

## VIII. THE CODE

### F. Special Exempt/Wild Card Non-Appearance

A player who accepts a wild card or a special exempt pursuant to the procedures set forth under section 7.10, special exempts, shall appear for play. A violation of this section would be considered as a late withdrawal and be subject to the penalties set forth under late withdrawals.

### G. Qualifying Non-Appearance

A player who was entered into the qualifying competition pursuant to the provisions set forth under qualifying/sign in or accepts a wild card in qualifying, shall appear for play. A violation of this section shall result in a fine of \$1,000 at ATP World Tour 250 tournaments and \$250 at ATP Challenger Tour tournaments in addition to any other fines provided in the Code. Fines shall be doubled in the case of any player who would have been seeded.

### H. Payment of Fines

The player shall pay all fines to the ATP within ten (10) days after the notice of fine is provided to the player. All collected entry/withdrawal fine amounts, with the exception of Challenger fines, shall be returned to the event from which the fine was incurred.

### I. Playing Another event

- 1) No player who has entered and been accepted into the main draw or qualifying of an ATP World Tour or ATP Challenger Tour tournament shall play in any other tennis event during the period of such tournament, except if appropriately released by the ATP. Once a player enters and is accepted into the main draw or qualifying of the singles or doubles competition, he is committed to that tournament for the week, unless released by the Executive Vice President - Rules & Competition or supervisor. A violation of this section shall constitute the Major Offense of Aggravated Behavior.
- 2) A player who has entered and been accepted into the main draw of an ATP World Tour or ATP Challenger Tour tournament shall be permitted to sign-in and compete in the doubles event if he withdraws his singles entry after 12 noon Eastern Time, USA, on the Friday before the tournament provided he is determined by the supervisor, upon written medical advice, to be physically capable to compete on a professional level of play.
- 3) A player may receive permission from a tournament director of an ATP World Tour 250 tournament to compete in a special event on the Monday of that tournament.

### J. Repeal of Withdrawal Fines and/or Penalties

#### 1) ATP World Tour 250

##### a) Consecutive Withdrawals

- i) Players with multiple consecutive withdrawals who are out of competition for thirty (30) days or more due to injury will not be subject to a fine as long as verified and approved medical forms are provided.  
**Note:** For consecutive withdrawals, the count shall begin on the withdrawal deadline date; the date of the retirement; the date of the late with-

## VIII. THE CODE

drawal; or the date of the on-site withdrawal, whichever was chronologically first.

- ii) A player must not compete in any other tennis event during those periods.

#### b) On-Site Medical Examination.

Players who withdraw after 12 noon Eastern Time, USA on Friday (or in the case of doubles, after the entry deadline) before a tournament shall not have the late withdrawal fine assessed if determined to be unfit to play that week if:

- i) The player who is still competing in a tournament or Davis Cup\* after the Friday 12 noon deadline is forced to withdraw/retire and is examined by that event's doctor and determined to be unfit for the following week's tournament; or
- ii) The player was on-site at the event when the withdrawal occurred and is determined to be unfit for play by that tournament's doctor. Players who are examined by the on-site tournament doctor shall receive tournament provided hotel rooms through the night of the examination.

\*A withdrawal from Davis Cup must be from a "live" match, for medical reasons.

#### c) Promotional Activities.

A player who was not on-site when the withdrawal/late withdrawal occurred but travels to the tournament within the first three (3) days of the main draw, unless otherwise determined by the ATP, and participates in a reasonable amount of promotional activities over a two (2) day period, as determined by the ATP, shall not have the applicable fines assessed. Players who travel to the event to complete their promotional activity requirement shall receive full hospitality from the day of arrival through the night following the completion of their promotional obligation.

#### d) Appeal.

The player may appeal the fine to the EVP-Rules and Competition as specified below under "Review of Penalties for Entry and Commitment Offenses".

### 2) ATP World Tour 500

#### a) Consecutive Withdrawals

- i) Players with multiple consecutive withdrawals who are out of competition for thirty (30) days or more due to injury will not be subject to a late withdrawal fine or a ranking penalty as long as verified and approved medical forms are provided.

**Note:** For consecutive withdrawals, the count shall begin on the withdrawal deadline date; the date of the retirement; the date of the late withdrawal; or the date of the on-site withdrawal, whichever was chronologically first.

- ii) A player must not compete in any other tennis event during those periods.

#### b) On-Site Medical Examination.

Players who withdraw after 12 noon Eastern Time, USA on Friday (or in the case of doubles, after the entry deadline) before a tournament shall not have the late withdrawal fine or ranking penalty assessed if determined to be unfit to play that week if:

- i) The player who is still competing in a tournament or Davis Cup\* after the Friday 12 noon deadline is forced to withdraw/retire and is examined by that event's Doctor and determined to be unfit for the following week's tournament; or

## VIII. THE CODE

- ii) The player was on-site at the event when the withdrawal occurred and is determined to be unfit for play by that tournament's doctor. Players who are examined by the on-site tournament doctor shall receive tournament provided hotel rooms through the night of the examination.
    - \* A withdrawal from Davis Cup must be from a "live" match, for medical reasons.
  - c) **Promotional Activities.**

A player who was not on-site when the withdrawal/late withdrawal occurred but travels to the tournament within the first three (3) days of the main draw, unless otherwise determined by the ATP, and participates in a reasonable amount of promotional activities over a two (2) day period, as determined by the ATP, shall not have the applicable fine and ranking penalties assessed. Players who travel to the event to complete their promotional activity requirement shall receive full hospitality from the day of arrival through the night following the completion of their promotional obligation.
  - d) **Appeal.**

The player may appeal the fine and ranking penalty to the Appeals Tribunal as specified below under "Review of Penalties for Entry and Commitment Offenses".
  - e) **Replacement Event.** A player who has received a zero (0) point ranking penalty for withdrawing from an ATP World Tour 500 event may replace the zero (0) point by playing an additional ATP World Tour 500 event in that same calendar year for a total of four (4) played. The replacement tournament must be after the 500 withdrawal that has resulted in a ranking penalty. Only one (1) additional ATP World Tour 500 event per year may be used to replace an ATP World Tour 500 ranking penalty.
- 3) ATP World Tour Masters 1000**
- a) **On-Site Medical Examination.**

Players who withdraw after 12 noon Eastern Time, USA on Friday (or in the case of doubles, after the entry deadline) before a tournament shall not have the late withdrawal fine and the suspension assessed if determined to be unfit to play that week if:

    - i) The player who is still competing in a tournament or Davis Cup\* after the Friday 12 noon deadline is forced to withdraw/retire and is examined by that event's Doctor and determined to be unfit for the following week's tournament; or
    - ii) The player was on-site at the event when the withdrawal occurred and is determined to be unfit for play by that tournament's doctor. Players who are examined by the on-site tournament doctor shall receive tournament provided hotel rooms through the night of the examination.
      - \* A withdrawal from Davis Cup must be from a "live" match, for medical reasons.
  - b) **Promotional Activities.**

A player who was not on-site when the withdrawal/late withdrawal occurred but travels to the tournament within the first three (3) days of the main draw, unless otherwise determined by the ATP, and participates in a reasonable amount of promotional activities over a two (2) day period, as determined by the ATP, shall not have the applicable fine and suspension penalties assessed. Players who travel to the event to complete their promotional activity

## VIII. THE CODE

- requirement shall receive full hospitality from the day of arrival through the night following the completion of their promotional obligation.
- c) **Appeal.**

The player may appeal the fine and suspension to the Appeals Tribunal as specified below under "Review of Penalties for Entry and Commitment Offenses".
- 4) ATP Challenger Tour/ATP World Tour Masters 1000 Qualifying and ATP World Tour 500 Qualifying**
- a) **Consecutive Withdrawals**
    - i) Players with multiple consecutive withdrawals who are out of competition for 30 days or more due to injury will not be subject to a fine as long as verified and approved medical forms are provided.
    - ii) A player must not compete in any other tennis event during those periods.**Note:** For consecutive withdrawals, the count shall begin on the withdrawal deadline date; the date of the retirement; the date of the late withdrawal; or the date of the on-site withdrawal, whichever was chronologically first
  - b) **On-Site Medical Examination.**

Players who withdraw after 12 noon Eastern Time, USA on Friday (or in the case of doubles, after the entry deadline) before a tournament shall not have the late withdrawal fine assessed if determined to be unfit to play that week if:

    - i) The player who is still competing in a tournament or Davis Cup\* after the Friday 12 noon deadline is forced to withdraw/retire and is examined by that event's doctor and determined to be unfit for the following week's tournament; or
    - ii) The player is examined on-site, at the event from which he withdrew, and determined to be unfit for play by that tournament's doctor during qualifying or within the first three (3) days of the main draw for Challengers. Players who are examined by the on-site tournament doctor shall receive tournament provided hotel rooms through the night of the examination.
      - \* A withdrawal from Davis Cup must be from a "live" match, for medical reasons.
  - c) **Appeal.**

The player may appeal the fine and ranking penalty to the EVP, Rules and Competition as specified below under "Review of Penalties for Entry and Commitment Offenses".
- No Penalty After Retirement**  
**Case:** *A player is injured at an ATP World Tour tournament and is forced to retire from his match. He is also unable to compete in the next week's tournament. The injury occurred after 12 noon, Friday, Eastern Time, USA. Must the player travel to the next tournament to be examined by that tournament's doctor to avoid the appropriate penalties.*  
**Decision:** *No. If the player is forced to retire he may be examined by that tournament's doctor.*

## VIII. THE CODE

### K. Review of Penalties for Entry and Commitment Offenses

Any player found to have committed an ATP World Tour Masters 1000 or ATP World Tour 500 entry or commitment offense may petition the Appeal Tribunal for discretionary review. ATP World Tour 250, ATP World Tour Masters 1000 Qualifying, ATP World Tour 500 Qualifying and ATP Challenger Tour appeals shall be submitted to and determined by the ATP Executive Vice President – Rules and Competition. This written petition shall detail the basis for the appeal.

1) **Deadline.** The deadline for filing an appeal is as follows:

**ATP World Tour Masters 1000** - 6:00 PM Eastern USA on the Tuesday of the event week; except that:

Indian Wells shall be the first Friday of the tournament week; and

Miami shall be the first Thursday of the tournament week.

If the Tribunal requests additional information, the player will have 24 hours from receipt of this notice to submit the requested information.

**ATP World Tour 500** - 10 days from the Monday of the event week.

If the Tribunal requests additional information, the player will have 48 hours from receipt of this notice to submit the requested information.

**ATP World Tour 250/ATP World Tour Masters 1000 Qualifying, ATP World Tour 500 Qualifying/ATP Challenger Tour** - 10 days from the Monday of the event week.

If the EVP - Rules and Competition requests additional information, the player will have 48 hours from receipt of this notice to submit the requested information.

Appeals must be submitted in writing to the Appeals Tribunal/EVP - Rules and Competition and received prior to the deadline. Send electronically via email or fax to:

Gayle David Bradshaw  
Executive Vice President, Rules & Competition  
201 ATP Tour Boulevard  
Ponte Vedra Beach, Florida 32082 USA

Email: gbradshaw@atpworldtour.com  
Facsimilie: +1 904 779 3300

2) **Determination.** The Tribunal President/EVP Rules and Competition shall review the petition and make a determination within the following time period:

**ATP World Tour Masters 1000** - 12 Noon Eastern USA on the Friday\* of the event week.

\*For Indian Wells and Miami the determination shall be made by 12 Noon Eastern USA on the 2nd Friday of the event.

**ATP World Tour 500** - 20 days from the Monday of the event week.

**ATP World Tour 250/ATP World Tour Masters 1000 Qualifying and ATP World Tour 500 Qualifying/ATP Challenger Tour** - 20 days from the Monday of the event week.

## VIII. THE CODE

3) **Scope of determination.** The Tribunal's/EVP - Rules and Competition decision on each case is limited to the following:

**ATP World Tour Masters 1000**

Suspension

Late Withdrawal Fine, if applicable.

**ATP World Tour 500**

Ranking penalty

Late Withdrawal Fine, if applicable.

**ATP World Tour 250/ATP World Tour Masters 1000 Qualifying, ATP World Tour 500 Qualifying/ATP Challenger Tour**

Withdrawal Fine

Late Withdrawal Fine

### L. Tribunal.

The ATP Board of Directors and President shall nominate designees for the appeals tribunal as follows:

- 1) The three members of the board representing the players shall nominate a designee to serve a one (1) year term on the tribunal.
- 2) The three members of the board representing the tournaments shall nominate a designee to serve a one (1) year term on the tribunal.
- 3) The President of the ATP shall nominate a designee to serve a one (1) year term on the tribunal.
- 4) **Medical Advisor.**
  - a) A person nominated by the medical services committee shall be present, if requested by the three (3) voting members of the Tribunal, at all tribunal meetings to offer advice and expert opinion on medical matters presented to the Tribunal.
  - b) The advisor has no vote in any appeal decisions.

### M. On-Site Offenses/Procedures

The on-site offense provisions shall apply to every player during his participation in an ATP World Tour or ATP Challenger Tour tournament. On-site includes tournament hotels, transportation, all tournament facilities and activities.

#### 1) Dress and Equipment

Every player shall dress and present himself for play in a professional manner. Clean and customarily acceptable tennis attire as approved by the ATP shall be worn. A player who violates this section may be ordered by the chair umpire or supervisor to change his attire or equipment immediately. Failure of a player to comply with such order may result in an immediate default.

##### a) Doubles Teams

Members of a doubles team shall be dressed in tennis wear that is substantially the same color.

## VIII. THE CODE

### b) Identification/Visible

No visible identification shall be permitted on a player, his clothing, products or equipment on court during a match or at any press conference or tournament ceremony, except as follows:

#### i) ATP Definitions.

1. **Clothing Designs.** Clothing designs will not be interpreted as manufacturer's logos and such logos can be incorporated into the clothing design, provided they conform to the size and placement restrictions.
2. **Commercial Identification.** Corporate or product identification other than the manufacturer of the item.
3. **Clothing Sponsor.** Company designated as the sponsor of the player's clothing (not a clothing manufacturer). A player may have no more than one clothing sponsor at any time.
4. **Tennis Equipment Manufacturer.** The tennis equipment manufacturer is the entity that distributes, or offers for sale, tennis racquets, clothing, strings or shoes.
5. **Clothing Manufacturer or Clothing Sponsor Logo.** Clothing manufacturer or clothing sponsor logo is the corporate or product identification, trademarks (regardless of registration status) or other recognizable names presented in the form of a logo or mark on the clothing product in question.
6. **Size Limitation.**
  - If a patch, the size is determined by the area of the actual patch. If a solid color patch is the same color as the clothing, then the size of the actual patch will be determined by the size of the logo identification, as described below.
  - If not a patch, the area of a logo or mark shall be determined by the circumference of a circle or the perimeter of a triangle or rectangle drawn around the logo or mark.

ii) **ATP Patch.** The ATP patch, with no sponsor affiliation, will be required on any shirt, sweater or jacket where a clothing sponsor logo is placed on the front or collar of such shirt, sweater or jacket. However, in the event the clothing sponsor is also the apparel manufacturer of the player's apparel, then the ATP patch shall not be a requirement.

1. The size of the ATP patch shall be two (2) square inches (13 sq. cm.).
2. The placement of the ATP patch shall be centered below the collar on the back of the shirt, sweater or jacket.

iii) **Logo Usage.** All logos or patches must be firmly attached at all points on the clothing or equipment.

1. **Bags, Towels or Other Items.** Standard logos of tennis equipment manufacturers on each item plus two (2) separate commercial identifications on one (1) bag, neither of which may exceed four (4) square inches (26 sq. cm.).
2. **Drink Containers.** Players are permitted to use drink containers on-court if they are of reasonable size and they contain no logo or writing of the manufacturer. The ATP has designated three (3) beverage categories of drinks for purposes of this rule: water, electrolyte or other drinks. The supervisor may approve for use on-court a reasonably sized drink container that has a logo or writing, not to exceed four (4) square inches (26 sq. cm.) if:

## VIII. THE CODE

- The center court drink sponsor is the same as the player's drink container manufacturer, or;
- The advertised center court drink sponsor(s) is not in the same beverage category as the player's drink container.

3. **Hat, Headband or Wristband.** One (1) standard logo of a clothing manufacturer, clothing sponsor or a tennis equipment manufacturer, which may contain writing, not to exceed four (4) square inches (26 sq. cm.).

4. **Racquet.** Standard logos of the manufacturer shall be permitted on racquets and strings.

#### 5. Shirt, Sweater or Jacket.

- **Front, Back and Collar.** Two (2) standard logos of the clothing manufacturer or clothing sponsor, neither of which exceeds two square inches (13 sq. cm.) may be placed in any location (i.e. 2 on the front, or 1 on the back and 1 on the collar, etc.) or one (1) standard logo of the clothing manufacturer or clothing sponsor, which may not exceed four (4) square inches (26 sq. cm.) may be placed on the front or collar. If the logo is the clothing manufacturer of the player's apparel, then an additional clothing manufacturer logo, not to exceed four (4) square inches (26 sq. cm.), may be placed on the back. Logos may contain writing.
- **Sleeves.** One (1) commercial (i.e., non-clothing manufacturer or clothing sponsor) identification for each sleeve, neither of which exceeds four (4) square inches (26 sq. cm), plus one (1) clothing manufacturer's or clothing sponsor's logo on each sleeve, neither of which exceeds four (4) square inches (26 sq. cm). Logos may contain writing.
- **Sleeveless.** If a garment does not have sleeves, then the two (2) commercial (non-manufacturer) identifications permitted on the sleeves above, neither of which shall exceed four (4) square inches (26 sq. cm.) in size, may be placed on the front of the garment. Logos may contain writing.
- **Other.** A logo of the clothing manufacturer, without the name of the manufacturer or any other writing, may be placed once or repeatedly within an area not to exceed twelve (12) square inches (77.5 sq. cm.) in one of the following positions:
  - a. on each of the shirt sleeves (if not on the sleeves as a clothing sponsor pursuant to the previous paragraph), or
  - b. On the outer seams (sides of torso) of the shirt.

#### 6. Shorts.

- **Front and Back.** Two (2) standard logos of the clothing manufacturer or clothing sponsor, neither of which exceeds two (2) square inches (13 sq. cm.), may be placed on the front or back of the shorts; or two (2) standard logos of the clothing manufacturer or clothing sponsor neither of which exceeds four (4) square inches (26 sq. cm), may be placed as follows: one (1) logo on the front and one (1) logo on the back of the shorts. Logos may contain writing.
- Compression shorts may contain two (2) standard logos of he



## VIII. THE CODE

clothing manufacturer or clothing sponsor, which must not exceed two (2) square inches (13 sq. cm.) or one (1) standard logo of the clothing manufacturer or clothing sponsor, which must not exceed four (4) square inches (26 sq. cm.).

7. **Socks /Shoes.** Standard logos of a clothing sponsor or the manufacturer of the article may appear on each sock and each shoe. The logos on the sock(s) on each foot shall be limited to a maximum of two (2) square inches (13 sq. cm.).

### **Tattoo as Logo**

**Case:** *A player arrives on court wearing an approved sleeveless shirt. The chair umpire notices that the player has a tattoo of the clothing manufacturer on his upper arm. If there is no issue with the size, is this allowed?*

**Decision: No.** *The rules for both clothing sponsor and commercial I.D. logo placement clearly specify where these logos may be placed.*

- iv) **Restrictions /Government.** The ATP may prohibit any commercial identification that would violate any governmental restrictions with respect to television.
- v) **Restrictions/Other Tennis event.** The identification by use of the name, emblem, logo, trademark, symbol or other description of any tennis circuit, series of tennis events, tennis exhibition or tournament other than the "ATP" is prohibited on all dress or equipment at any ATP World Tour and ATP Challenger Tour tournaments, unless otherwise approved by the ATP.
- vi) **Restrictions /Timing.** After beginning to wear a clothing sponsor logo, a player may not wear a different clothing sponsor logo for a period of twelve (12) months, unless the different clothing sponsor is the manufacturer of player's apparel. Additionally, a player may not wear a new or different clothing sponsor logo at a tournament after such tournament has commenced, unless the new or different clothing sponsor is the manufacturer of player's apparel.
- vii) **Restrictions /Tournament Sponsor Conflict.** In the event a player's clothing sponsor conflicts with or is a competitor of the primary sponsor (i.e., title sponsor or presenting sponsor(s) if no title sponsor) of the tournament in which the player is a finalist, during both the trophy presentation and the post-match press conference (i) an article of clothing will be provided to player so that the clothing sponsor's logo on the front of the player's shirt, sweater or jacket is covered, and (ii) the player will remove his hat (if the clothing sponsor logo appears on the hat).
- viii) **Restrictions / General.** Tobacco and companies associated with gambling will be prohibited from any endorsements on player clothing.
- c) **Shoes**
- i) **General.** Players are required to wear tennis shoes generally accepted as proper tennis attire. Shoes shall not cause damage to the court other than what is expected during the normal course of a match or practice. Damage to a court may be considered as physical or visible, which may include a shoe that leaves marks beyond what is considered acceptable. The Supervisor has the authority to determine that a shoe does not

## VIII. THE CODE

meet the criteria of "customarily acceptable" and may order the player to change.

- ii) **Clay Courts.** Players are required to wear tennis shoes generally accepted for play on clay courts or granular surfaces. The supervisor has the authority to determine that a tennis shoe's sole does not conform and can prohibit its use at any ATP World Tour or ATP Challenger Tour tournament. Grass court shoes should not be worn during a match on clay courts.
- iii) **Grass Courts.** In ATP World Tour and ATP Challenger Tour tournaments played on grass courts, no shoes other than those with rubber soles, without heels, ribs, studs or covering, shall be worn by players.
- aa) Special grass court shoes shall not be used without the express approval of the ATP, based on the following specifications:
- 1) The pimples or studs on the base of the sole should be vertical from the outsole and shall have a maximum top diameter of three (3) millimeters and a minimum top diameter of two (2) millimeters. The maximum height of the pimples or studs shall be two (2) millimeters, from the base of the shoe. The hardness of any pimple or studs shall be between 55 and 60 based on a Shore "A" scale. The number of pimples per square inch shall be no less than 15 and no more than 28.
  - 2) Shoes with pimples or studs around the outside of the toes shall not be permitted. The foxing / sidewall can be contoured only in the medial forefoot and medial toe area but only within the following restrictions. The contoured area may begin in the transition area between outsole and sidewall but can only go to a maximum of 1.5 cm up the sidewall. This contoured area must be flat (not textured or undulating) but can be stepped with no more than 5 steps each no more than 1 mm in depth.
  - 3) Forefoot and heel areas may be separated but there should be no more than a 2 mm step in the outsole of the shoe.
    - Approval of special grass court shoes should be received by the ATP at least ninety (90) days in advance of the grass court tournament.

**All shoes approved for play in 2008 shall continue to be approved.**

### **d) Violations/Fines**

- Any player who violates this section and is not defaulted shall be subject to the following fines:
- i) **Commercial Identification.** Violation of the provisions with respect to commercial identifications shall result in a fine of \$2,000.
  - ii) **Tennis Equipment Manufacturer's logo.** Violation of the provisions with respect to standard logos of manufacturers shall result in a fine of \$500.
  - iii) **Other Tennis event.** Violation of the provisions with respect to the name of an event other than the "ATP" shall result in a fine up to \$5,000.
  - iv) **Unacceptable Attire and Doubles Team Attire.** Violation of the provisions with respect to unacceptable attire or doubles team attire shall result in a fine up to \$1,000.
  - v) **Clothing Sponsor/ATP Patch.** Violations of the provisions with respect to clothing sponsor logos and the ATP patch shall result in a fine of up to \$2,000.

## VIII. THE CODE

### 2) Point Penalty Schedule

- a) The Point Penalty Schedule to be used for Code Violations is as follows:
- |                                   |               |
|-----------------------------------|---------------|
| FIRST OFFENSE                     | WARNING       |
| SECOND OFFENSE                    | POINT PENALTY |
| THIRD AND EACH SUBSEQUENT OFFENSE | GAME PENALTY  |
- However, after the third Code Violation, the supervisor shall determine whether each subsequent offense shall constitute a default.
- b) In ATP World Tour and ATP Challenger Tour tournaments and events, Code Violations shall be levied by the chair umpire for on-court offenses. In the event that the chair umpire fails to levy a code violation, then the supervisor may order him to do so.
- c) In doubles, code violations shall be assessed against the team.

### 3) Code Violations Not Witnessed By Chair Umpire

Occasionally, there are code violations by players that are not witnessed by the chair umpire. The line umpire should immediately approach the chair umpire and report the facts of the violation, during which time the chair umpire should turn off all microphones in the area of the chair. The chair umpire may ask the player to respond to such report; thereafter, the chair umpire must make a decision and he either dismisses the report or declares a code violation and assesses a penalty. If a code violation is assessed, then the chair umpire must announce such violation to the player, opponent and spectators. If in his opinion there was a code violation, but because of the time of discovery or other reasons a penalty pursuant to the Point Penalty Schedule would be inappropriate, then he must notify the player that he will refer the matter to the supervisor for action.

The supervisor may order the chair umpire to issue a code violation for a violation witnessed or not witnessed by the chair umpire.

### 4) Offenses

#### a) Ball Abuse

- i) Players shall not violently, dangerously or with anger hit, kick or throw a tennis ball while on the grounds of the tournament site except in the reasonable pursuit of a point during a match (including warm-up). For purposes of this rule, abuse of balls is defined as intentionally or recklessly hitting a ball out of the enclosure of the court, hitting a ball dangerously or recklessly within the court or hitting a ball with disregard of the consequences.
- ii) Violation of this section shall subject a player to a fine of up to \$350 for each violation. In addition, if such violation occurs during a match, the player shall be penalized in accordance with the Point Penalty Schedule.

#### b) Racquet or Equipment Abuse

- i) Players shall not violently, dangerously or with anger hit, kick or throw a racquet or other equipment within the precincts of the tournament site. For purposes of this rule, abuse of racquets or equipment is defined as intentionally, dangerously and violently destroying or damaging racquets or equipment or intentionally and violently hitting the net, court, umpire's chair or other fixture during a match out of anger or frustration.
- ii) Violation of this section shall subject a player to a fine up to \$500 for each violation. In addition, if such violation occurs during a match, the player shall be penalized in accordance with the Point Penalty Schedule.

## VIII. THE CODE

### c) Physical Abuse

- i) Players shall not at any time physically abuse any official, opponent, spectator or other person within the precincts of the tournament site. For purposes of this rule, physical abuse is the unauthorized touching of an official, opponent, and spectator or other person.
- ii) Violation of this section shall subject a player to a fine up to \$10,000 for each violation. In addition, if such violation occurs during a match, the player shall be penalized in accordance with the Point Penalty Schedule. In circumstances that are flagrant and particularly injurious to the success of a tournament, or are singularly egregious, a single violation of this section shall also constitute the player Major Offense of Aggravated Behavior.

### d) Verbal Abuse

- i) Players shall not at any time directly or indirectly verbally abuse an official, opponent, sponsor, spectator or any other person within the precincts of the tournament site. Verbal abuse is defined as any statement about an official, opponent, sponsor, spectator or any other person that implies dishonesty or is derogatory, insulting or otherwise abusive.
- ii) Violation of this section shall subject a player to a fine up to \$10,000 for each violation. In addition, if such violation occurs during a match, the player shall be penalized in accordance with the Point Penalty Schedule. In circumstances that are flagrant and particularly injurious to the success of a tournament, or are singularly egregious, a single violation of this section shall also constitute the player Major Offense of Aggravated Behavior.

### e) Audible Obscenity

- i) A player shall not use an audible obscenity while on-site. Audible obscenity is defined as the use of words commonly known and understood to be profane and uttered clearly and loudly enough to be heard.
- ii) Violation of this section shall subject a player to a fine up to \$5,000 for each violation. In addition, if such violation occurs during a match, the player shall be penalized in accordance with the Point Penalty Schedule. In circumstances that are flagrant and particularly injurious to the success of a tournament, or are singularly egregious, a single violation of this section shall also constitute the player Major Offense of Aggravated Behavior.

### f) Visible Obscenity

- i) Players shall not make obscene gestures of any kind while on-site. Visible obscenity is defined as the making of signs by a player with hands and/or racquet or balls that commonly have an obscene meaning.
- ii) Violation of this section shall subject a player to a fine up to \$5,000 for each violation. In addition, if such violation occurs during a match, the player shall be penalized in accordance with the Point Penalty Schedule. In circumstances that are flagrant and particularly injurious to the success of a tournament, or are singularly egregious, a single violation of this section shall also constitute the player Major Offense of Aggravated Behavior.

### g) Unsportsmanlike Conduct

- i) Players shall at all times conduct themselves in a sportsmanlike manner and give due regard to the authority of officials and the rights of op-

## VIII. THE CODE

ponents, spectators and others. Unsportsmanlike conduct is defined as any misconduct by a player that is clearly abusive or detrimental to the success of a tournament, the ATP and/or the Sport. In addition, unsportsmanlike conduct shall include, but not be limited to, the giving, making, issuing, authorizing or endorsing any public statement having, or designed to have, an effect prejudicial or detrimental to the best interest of the tournament and/or the officiating thereof.

- ii) Violation of this section shall subject a player to a fine up to \$10,000 for each violation. In addition, if such violation occurs during a match, the player shall be penalized in accordance with the Point Penalty Schedule. In circumstances that are flagrant and particularly injurious to the success of a tournament, or are singularly egregious, a single violation of this section shall also constitute the player Major Offense of Aggravated Behavior.
- h) Best Efforts**
  - i) A player shall use his best efforts during the match when competing in a tournament. Violation of this section shall subject a player to a fine up to \$10,000 for each violation.
  - ii) For purposes of this rule, the supervisor and/or the chair umpire shall have the authority to penalize a player in accordance with the Point Penalty Schedule. In circumstances that are flagrant and particularly injurious to the success of a tournament, or are singularly egregious, a single violation of this section shall also constitute the player Major Offense of Aggravated Behavior.
- i) Leaving the Court**
  - i) A player shall not leave the court area during a match (including the warm-up) without the permission of the chair umpire or supervisor.
  - ii) Violation of this section shall subject a player to a fine up to \$3,000 for each violation. In addition the player may be defaulted and shall be subject to the additional penalties for failure to complete match.
- j) Failure to Complete Match**
  - i) A player must complete a match in progress unless he is reasonably unable to do so.
  - ii) Violation of this section shall subject a player to a fine up to \$5,000. Violation of this section shall subject a player to immediate default and shall also constitute the Major Offense of Aggravated Behavior.
- k) Ceremonies**
  - i) All tournament finalists must attend and participate in the post-match ceremonies, unless he is physically unable to do so as determined by the tournament Doctor. This includes retirements and finals not played due to a walkover.
  - ii) Violation of this section shall subject a player to a fine up to \$5,000.
- l) Coaching and Coaches**
  - i) Players shall not receive coaching during a tournament match. Communications of any kind, audible or visible, between a player and a coach may be construed as coaching. Coaches on-site are prohibited from:
    - aa)** Using an audible obscenity or making obscene gestures of any kind.
    - bb)** Abusing any official, opponent, spectator or other person, verbally or physically.
    - cc)** Engaging in conduct contrary to the integrity of the game of tennis.

## VIII. THE CODE

Conduct contrary to the integrity of the game shall include, but not be limited to, comments to the news media that unreasonably attack or disparage a tournament, sponsor, player, official or the ATP. Responsible expressions of legitimate disagreement with the ATP policies are not prohibited. However, public comments that one of the stated persons above knows, or should reasonably know, will harm the reputation or financial best interest of a tournament, player, sponsor, official or the ATP are expressly covered by this section.

- ii) Violation of this section shall subject a player to a fine up to \$5,000 for each violation. In addition, if such violation occurs during a match, the player shall be penalized in accordance with the Point Penalty Schedule. In circumstances that are flagrant and particularly injurious to the success of a tournament, or are singularly egregious, the supervisor shall have the authority to relocate the position of a coach if there is reasonable belief that coaching is occurring or the supervisor may order the coach to be removed from the match site or tournament site and upon his failure to comply with such order, may declare an immediate default of such player.

### **Electronic devices**

**Case:** *May a player listen to an mp3 player or other device on a changeover?*

**Decision:** *A player is not allowed to use any electronic devices (e.g. CD players, mobile phones, etc.) during matches, unless approved by the Supervisor. (Tour Policy)*

### **m) Default**

- i) The supervisor may default a player either for a single violation of the Code (immediate default) or as outlined in the Point Penalty Schedule.
- ii) In all cases of default, the supervisor's decision shall be final and may not be appealed.

### **iii) Penalties:**

- aa)** Any player who is defaulted shall lose all prize money (gross prize money to be paid to the ATP), hotel accommodations and points earned for that event at that tournament.
  - bb)** At the discretion of the supervisor, the player may be withdrawn from all other events, if any, in that tournament.
  - cc)** In addition, if the Executive Vice President - Rules & Competition determines that the default was particularly injurious to the success of the tournament or detrimental to the integrity of the sport, he may consider additional penalties (fines and/or suspensions).
- iv) The exception is when the offending incident involves:
    - aa)** A violation of the punctuality or dress and equipment provisions set forth in the Code; or
    - bb)** As a result of a medical condition; or
    - cc)** A match ending on a delay penalty (Code Violation for Delay of Game) if the delay penalty was the result of a medical condition.
    - dd)** A member of a doubles team did not cause any of the misconduct code violations that resulted in the team being defaulted.

### **v) In doubles:**

- aa)** A default assessed for violation of the Code shall be assessed against the team.

## VIII. THE CODE

- bb) The supervisor will assess the default penalties against both players on the team, unless the provisions in 4 above apply.
- cc) At the discretion of the supervisor, one or both of the players may be withdrawn from all other events, if any, in that tournament.
- dd) The partner of the player who caused the default shall receive points and prize money from the previous round.

### **Default - List Penalties**

**Case:** *If a player is defaulted through the Code of Conduct for misconduct, what penalties result?*

**Decision:** *The player may be withdrawn from any other event he is entered in, as determined by the supervisor, loses all points and prize money earned at the tournament (gets paid to the ATP), and hotel accommodations, in addition to the fines that may be imposed for the code violations.*

### **n) Punctuality**

Players shall be ready to play when their matches are called.

- i) Any player not ready to play within ten (10) minutes after his match is called shall be fined \$250.
- ii) Any player not ready to play within fifteen (15) minutes after his match is called may be fined up to an additional \$750 and shall be defaulted unless the supervisor, after consideration of all relevant circumstances, elects not to declare a default. In such case, the supervisor shall immediately inform the Executive Vice President - Rules & Competition. This section applies only to those players who are or have been on site.

### **Late Transportation**

**Case:** *The scheduled transportation is late to pick up players from the tournament hotel. A player is defaulted for punctuality and subsequently arrives on-site with tournament transportation. Should the default be rescinded and the match played?*

**Decision:** *The player is defaulted. Transportation is a service provided by the tournament; however, the player is responsible for arriving on time for his match.*

### **o) Continuous Play / Delay of Game**

Following the expiration of the warm-up period, play shall be continuous and a player shall not unreasonably delay a match for any cause. A maximum of twenty-five (25) seconds shall elapse from the moment the ball goes out of play until the time the ball is struck for the next point. If such serve is a fault, then the second serve must be struck by the server without delay. The exception is at a ninety (90) second changeover or a one hundred twenty (120) set break. The procedures for enforcing this rule are as follows:

- i) **25 Seconds Between Points.**
  - aa) Start stopwatch when the player is ordered to play or when the ball goes out of play.
  - bb) Assess time violation or code violation if the ball is not struck for the next point within the twenty-five (25) seconds allowed. There is no time warning prior to the expiration of the twenty-five (25) seconds.
- ii) **Changeover (Ninety (90) Seconds) and Set Break (One Hundred and Twenty (120) Seconds).**

## VIII. THE CODE

- aa) Start stopwatch the moment the ball goes out of play.
- bb) Announce "Time" after sixty (60) / ninety (90) seconds have elapsed.
- cc) Announce "15 Seconds" if one or both of the players are still at their chairs and/or have not started toward their playing positions after seventy-five (75) / one hundred and five (105) seconds have elapsed.
- dd) Assess time violation or code violation (after medical time-out or treatment) if the ball is not struck for the next point within the ninety (90) / one hundred and twenty (120) seconds allowed provided there has been no interference which prevented the server from serving within that time.

**NOTE:** When requested by television, "Time" shall be announced after ninety (90) seconds for a changeover and one hundred twenty (120) seconds for a set break.

### **iii) Receiver not playing to the reasonable pace of the server**

- aa) Start stopwatch the moment the ball goes out of play or when the player is ordered to play.
- bb) Assess time violation (also before expiration of twenty-five (25) seconds) if the receiver's actions are delaying the reasonable pace of the server.
- cc) Assess code violation if the receiver is consistently or obviously delaying the server, thus employing "Unsportsmanlike Conduct".

### **p) Media Conference**

- i) All players scheduled to play on televised courts will be required, if requested, to perform a pre-match TV interview on the day of the match (not to exceed 2 minutes in total). The interview may be conducted at either the player's practice court or as the players approach the court for walk-on as determined by the host and player's national broadcasters.
- ii) All players who win during a televised match will be required to perform on court TV interviews, if requested, with the host and player's national broadcaster(s) for that match (not to exceed 5 minutes in total).
- iii) All players will be required to perform post-match radio and TV news service interviews directly following the post-match press conference (not to exceed 10 minutes in total). If there is no post-match press conference, the interviews will need to take place within 30 minutes of the conclusion of their match.
- iv) Unless injured and physically unable to appear, a player or team must attend the post-match media conference organized within thirty (30) minutes after the conclusion of each match whether the player or team was the winner or loser, unless such time is extended by the supervisor for good cause. Post-match media obligations include two (2) interviews, with the host and player's national broadcasters. This rule shall also apply to matches won or lost as a result of a withdrawal or retirement.
- v) Violation of this section shall subject a player to a fine in accordance with the following schedule:

## VIII. THE CODE

Fine Schedule (based on most recent position in the South African Airways ATP Rankings (singles):

1 - 10	\$20,000
11 - 25	\$10,000
26 - 50	\$5,000
51 - 100	\$3,000
101 +	\$1,000

Fines will be increased to the next higher level for any national player. Fines will double for each repeat offense within an ATP Circuit Year.

For ATP Challenger Tour events, a violation of this section shall result in a fine of \$500.

### q) Media Availability

All players will be required, if requested, to take part in media availability (not to exceed 2 hours in total) prior to and during each tournament.

### r) ATP STARS Program Penalties

Players shall be required to participate in ATP sponsored activities at each ATP World Tour tournament. Failure to participate in a scheduled activity due to non-appearance or tardiness shall be deemed a missed activity. Violation of this section shall subject a player to a fine as indicated below:

Fine Schedule (based on most recent position in the South African Airways ATP Rankings (singles):

1 - 10	\$20,000
11 - 25	\$10,000
26 - 50	\$5,000
51 - 100	\$3,000
101 +	\$1,000

Fines will be increased to the next higher level for any national player. Fines will double for each repeat offense within an ATP Circuit Year.

### s) Champion's Media Tour

Each winner of a Grand Slam or the Barclays ATP World Tour Finals, if requested, is obligated to participate in media tour as arranged by ATP during the days immediately following the finals of any such tournament. Players and their agents will be consulted with respect to the scope and substance of the activities to take place during the media tour to ensure that the player is comfortable with the proposed activities. ATP will cover all expenses incurred by a player while participating in the media tour.

### t) Special Functions

Each player, if requested, is obligated to attend the ATP Awards Show and up to two (2) additional ATP sponsored/conducted special events. Players and their agents will be consulted in advance to ensure that attendance at any such event(s) will not substantially intrude upon the player's schedule. Players and their agents will also be consulted with respect to the scope and

## VIII. THE CODE

substance of the events to ensure that the player is comfortable with attending the event(s).

### N. Cumulative On-Site Offenses

- 1) Any player who has accumulated \$10,000 in fines for any combination of player on-site offenses in ATP World Tour and ATP Challenger Tour tournaments during any twelve (12) month period shall have committed, for each such \$10,000 in fines, a cumulative offense and shall be additionally penalized as follows [ATP Challenger Tour tournament weeks shall not be included in suspensions for players positioned 1-10 on the South African Airways ATP Rankings (singles) (ATP World Tour tournament weeks only). Also tournament weeks do not include Grand Slam or Davis Cup weeks.

a) 1st Cumulative Offense	Notification Letter
b) 2nd Cumulative Offense	\$10,000 fine and eight (8) tournament week suspension of ATP World Tour and/or ATP Challenger Tour tournaments within a specified period of time
c) 3rd and Each Subsequent Offense	\$25,000 fine and eight (8) tournament week suspension of the ATP World Tour and/or ATP Challenger Tour tournaments within a specified period of time.

- 2) Any suspension resulting from a violation of this section shall commence either on the third Monday after the last day of the event in which the player received the fine that made the accumulation of \$10,000 or, in the case of an appeal, commencing on the first Monday after the appeal is unsuccessfully concluded, whichever is later. The ATP President or his designee shall have the discretion to reduce a suspension.
- 3) All fines levied by the Executive Vice President - Rules & Competition for violation of this section shall be paid by the player to the ATP within ten (10) days after receipt of written notice of the fine. In the case of an appeal of the fine that made the accumulation of \$10,000, all fines levied must be paid in USD within two (2) days after the appeal is unsuccessfully concluded.

### O. Determination of Violation and Penalty

- 1) The supervisor shall make a reasonable investigation to determine the facts regarding all player on-site offenses. Upon determining that a violation has occurred, the supervisor shall specify the fine and/or other punishment in written notice to the player. The supervisor may limit the fines levied during qualifying competition as follows:
  - a) ATP World Tour Tournament Qualifying Competition. A maximum of \$500 for each violation.
  - b) ATP Challenger Tour Tournament Qualifying Competition. A maximum of \$100 for each violation.
- 2) The Executive Vice President - Rules & Competition shall have the authority to investigate statements or actions made by a player that are not heard or seen by on-court officials by reviewing tapes of televised matches. After reviewing all facts and circumstances, the Executive Vice President - Rules & Competition

## VIII. THE CODE

may determine that a violation of the Code has occurred and shall specify the fine and/or other punishment. The player shall be given written notice of the violation and fine. The player shall have the right to appeal such determination to the ATP President, consistent with the procedures outlined in the Code.

### P. Payment of Fines

Fines levied by the supervisor for player on-site offenses shall be paid in accordance with the following:

- 1) **ATP World Tour and ATP Challenger Tour Tournaments.** Each tournament shall deduct fines from the player's winnings, if any, and promptly pay the fine to the ATP. In the event that the player's winnings are insufficient to pay the fine, the player shall pay the balance within twenty (20) days after the tournament to the ATP.
- 2) **ATP World Tour Team Championship.** The organizers of the World Team Championship competition shall deduct the fines from prize money due the player and pay the fine to the ATP. In the event that such prize money is less than the fine, delinquent amounts shall be reported to and subsequently collected by the ATP. All fines shall be assessed against the player for the purpose of the cumulative on-site offense provision.

### Q. Procedures for Appeal

- 1) Except for appeals of violations of the Stars Program, any player in violation of a player on-site offense may, after paying all fines, appeal to the Executive Vice President - Rules & Competition for review of a determination of guilt and the penalty assessed.
- 2) Any player found to have committed a player on-site offense may appeal such decision in writing to the Executive Vice President - Rules & Competition. Such appeal shall be lodged within ten (10) days of the on-site offense. The Executive Vice President - Rules & Competition shall review the Appeal within twenty-one (21) days and, if necessary, designate a date, time and place for a hearing. At the hearing, the player shall present to the Executive Vice President - Rules & Competition his respective positions on the facts. The Executive Vice President - Rules & Competition may affirm, reverse or modify the penalty initially imposed by the supervisor.

### R. Appeal of Violations of STARS Program

- 1) All appeals concerning the ATP STARS Program shall be governed by the procedures in this section.
- 2) A player can file a written appeal with the Executive Vice President - Rules & Competition within ten (10) days after the player's receipt of notification of a violation of the Stars Program. As a condition to filing an appeal, the player must pay the fine prescribed in the Program for the violation.
- 3) Upon receipt of a timely written appeal, the Executive Vice President - Rules & Competition, or his designee, shall appoint a committee to hear and decide the appeal, and also shall appoint one of the committee members to act as the committee's chairman. The ATP may provide reasonable compensation and reimbursement of expenses to committee members.

## VIII. THE CODE

- 4) The committee shall convene a hearing to hear the appeal and shall render its written decision on the case as soon as practicable following the conclusion of the hearing. The decision shall be by majority of the committee members.
- 5) The procedure prior to and at the hearing shall be at the discretion of the committee chairman, including but not limited to the decision to conduct the hearing by telephone conference or in person. In establishing such procedures, the chairman shall take into account the amount of the fine involved and any other relevant considerations.
- 6) The committee shall not be bound by judicial rules governing the procedure or the admissibility of evidence, provided that the hearing is conducted in a fair manner with a reasonable opportunity for each party to submit evidence, address the committee and present his or its case.
- 7) In all appeals, the ATP will appear and defend the finding of a violation, and shall have the burden of proving, by a preponderance of the evidence, that there has been a violation of the STARS Program.
- 8) The committee's decision shall be the full, final and complete disposition of the appeal and will be binding on all parties.
- 9) If the player's appeal is upheld, the Executive Vice President - Rules & Competition shall refund to the player the fine paid by the player in connection with this appeal.

### S. Notice and Service

- 1) Any written communication to be sent to the ATP President or Executive Vice President - Rules & Competition should be addressed as follows, unless notice of change is subsequently published.

ATP President	OR	EVP - Rules & Competition
IG House		ATP Americas
Paliser Road		201 ATP Blvd
London W14 9EB		Ponte Vedra Beach, FL 32082, USA
Telephone: +44 207 381 7890		Telephone: +1 904 285 8000
Facsimilie: +44 207 381 7895		Facsimilie: +1 904 779 3300

- 2) **Service.** Service to a player of any notice or other document shall be deemed completed if mailed to the player at his home address or other address designated by the player.

## 8.04 Player Major Offenses/Procedures

### A. Offenses

- 1) **Aggravated Behavior**
  - a) No player at any ATP World Tour or ATP Challenger Tour tournament shall engage in aggravated behavior which is defined as follows:
    - i) One or more incidents of behavior designated in this Code as constituting aggravated behavior.
    - ii) One incident of behavior that is flagrant and particularly injurious to the success of a tournament, or is singularly egregious, including the sale of credentials.
    - iii) A series of two (2) or more violations of this Code within a twelve (12)

## VIII. THE CODE

month period which singularly do not constitute aggravated behavior, but when viewed together establish a pattern of conduct that is collectively egregious and is detrimental or injurious to ATP World Tour or ATP Challenger Tour tournaments.

- b) Violation of this section shall subject a player to a fine up to \$25,000 or the amount of prize money won at the tournament, whichever is greater, and/or suspension from play in ATP World Tour and ATP Challenger Tour tournaments or events for a minimum period of twenty-one (21) days and a maximum period of one (1) year. The suspension shall commence on the Monday after the expiration of the time within which an appeal may be filed, or, in the case of appeal, commencing on the Monday after a final decision on appeal.

### 2) Conduct Contrary to the Integrity of the Game

The favorable reputation of the ATP, its tournaments and players is a valuable asset and creates tangible benefits for all ATP members. Accordingly, it is an obligation for ATP players, their coaches and family members to refrain from engaging in conduct contrary to the integrity of the game of tennis. Conduct contrary to the integrity of the game shall include, but not be limited to, comments to the news media that unreasonably attack or disparage a tournament, sponsor, player, official or the ATP. Responsible expressions of legitimate disagreement with ATP policies are not prohibited. However, public comments that one of the stated persons above knows, or should reasonably know, will harm the reputation or financial best interests of a tournament, player, sponsor, official or the ATP are expressly covered by this section. Violation of this section shall subject the player to a fine of up to \$100,000 and/or suspension from play in ATP World Tour or ATP Challenger Tour tournaments for a period of up to three (3) years.

### 3) Prohibited Promotional Fees

- a) ATP World Tour 500 and 250 tournaments and the ATP World Tour Team Championship have the option to offer fees for promotional services. No other ATP World Tour or ATP Challenger Tour tournament owner, operator, sponsor or agent is permitted to offer, give or pay money or anything of value, nor shall the tournament permit any other person or entity to offer, give or pay money or anything of value to a player, directly or indirectly, to influence or assure a player's competing in a tournament, other than prize money, unless authorized to do so by the ATP.
- b) Violation of this section shall subject the player to a fine up to \$20,000 plus the amount of value of any such payment, and/or to suspensions from play in ATP World Tour and ATP Challenger Tour tournaments for a period of up to three (3) years. The suspension shall begin on the Monday after the expiration of the time within which an appeal may be filed, or, in the case of appeal, commencing on the Monday after a final decision on appeal.
- c) If the Executive Vice President - Rules & Competition believes that a player may be violating this section, then upon demand, the player or his agent, must furnish or provide access to the Executive Vice President - Rules & Competition copies of all records relating to their participation in or, in the absence of such records, an affidavit setting forth the facts with respect to any transaction in question. In the event a player fails to provide the records or affidavit, the Executive Vice President - Rules & Competition may suspend him

## VIII. THE CODE

from participation in ATP World Tour and ATP Challenger Tour tournaments pending compliance with such demand.

### B. Procedures

#### 1) Determination and Penalty

The Executive Vice President - Rules & Competition shall conduct such investigation of an alleged player major offense as he, in his sole discretion, determines is appropriate and necessary. Upon completion of his investigation, the Administrator of Rules and Competition shall determine whether a player major offense has occurred and, if so, shall fix a penalty to be imposed. A copy of the decision setting forth such penalty shall be promptly delivered to the player.

#### 2) Payment of Fines

The player shall pay all fines levied for player major offenses to the ATP by delivery to the Executive Vice President - Rules & Competition within twenty-one (21) days after receiving written notice.

#### 3) Appeal

Any player who has received a penalty for a player major offense may, after paying all monetary fines, appeal such determination by filing a written notice with the President within five (5) days (excluding weekends) of such player's receipt of notice of such determination. Upon receiving such notice of appeal, the President or his designee shall set a date and place for the hearing.

#### 4) Hearing on Appeal

The President or his designee shall conduct the hearing on appeal in accordance with the following:

- a) **Burden of Proof.** The Executive Vice President - Rules & Competition has the responsibility to prove the violation by a preponderance of the evidence.
- b) **Rules.** The President or his designee must conduct the hearing in a fair and orderly manner with opportunity for each side to present its evidence as to the facts involved, and the player and his representative, if any, and the Executive Vice President - Rules & Competition are bound to cooperate fully to this end.
- c) **Statement of Position.** The President or his designee may request the Executive Vice President - Rules & Competition and the player to state in writing their respective positions on the facts, the provision(s) of the Code allegedly violated and the penalty specified and file the same with the President or his designee at least three (3) days prior to the hearing, with a copy to each other.
- d) **Presentation.** The Executive Vice President - Rules & Competition and the player may present evidence personally or through counsel. Each party shall have the right to present and to cross-examine witnesses, and to offer documentary evidence and testimony by affidavit or deposition. Except for purposes of rebuttal, documentary evidence and affidavits shall not be admissible unless a copy is submitted at least three (3) days prior to the hearing to the President or his designee and to the other party. Should objection be made to the introduction of an affidavit, the President or his designee may determine in his discretion that the interests of fairness require that the individual be produced to testify at the hearing, or alternatively, that such affidavit be ex-

## VIII. THE CODE

cluded. In the case of the former, a reasonable continuance may be granted for production of such witness.

- e) **Hearing.** The hearing shall be closed to the public. Once commenced, the hearing shall continue from day to day until concluded, unless the President or his designee allows otherwise. Postponements, adjournments or any form of delay shall be permitted only in the case of documented emergency and at the sole discretion of the President or his designee. Requests for postponement shall be submitted in writing to the President or his designee.
- f) **Record.** Each party shall have the right to have the hearing recorded or transcribed at its expense.
- g) **Interpreter-Legal Advisor.** The President or his designee may, at his discretion, make provisions for the presence of an interpreter and/or legal advisor for the hearing. The reasonable expenses of such interpreter or legal advisor shall be assumed by the ATP pending the final decision of the President or his designee and the taxing of costs as is provided in the decision on appeal.

### 5) Decision on Appeal

As soon as practicable after the conclusion of the hearing on appeal, the President or his designee shall render a written decision, which decision shall constitute the full, final and complete disposition of the issue and will be binding upon the player and upon all members of the ATP. The President or his designee may vacate, affirm or modify in whole or in part the penalty, but may not increase it. Notwithstanding the foregoing, the President or his designee may tax the losing party, whether the ATP or the player, all reasonable costs of the Appeal, including, but not limited to, the expenses and charges of the interpreter, legal advisor and any adverse witness required upon objection to testify concerning facts originally presented by way of affidavit. If the costs are taxed against a player, then they must be paid by the player to the ATP by delivery to the Executive Vice President - Rules & Competition within (10) days after receipt of the decision of the President or his designee.

## C. Suspensions and Collection of Fines

### 1) Suspension - Weeks/Scope

Whenever any suspension is involved as a penalty for a violation of the Code, only weeks with ATP World Tour or ATP Challenger Tour tournaments shall be included in the suspension period.

### 2) Stay of Suspensions Pending Appeal

Whenever a player is suspended by the ATP and an appeal either of right or discretionary review is filed, then the suspension shall be stayed pending the resolution of the appeal.

### 3) Suspension for Non-Payment of Fines

If a fine is not paid in a timely fashion, the ATP may suspend, pending payment, the party fined from further participation in any ATP World Tour and ATP Challenger Tour tournament. In addition, the ATP is authorized to collect all overdue fines along with costs, if any, by all reasonable means, including deduction of the fine from any subsequent winnings, or through legal proceedings. When a fine is deducted from prize money being paid in non-U.S. currency, the official ATP exchange rate shall be applicable to the payment of the fine, to the extent deducted.

## VIII. THE CODE

### 8.05 Uniform Tennis Anti-Corruption Program

#### A. Introduction

The purpose of the Uniform Tennis Anti-Corruption Program is to (i) maintain the integrity of tennis, (ii) protect against any efforts to impact improperly the results of any match and (iii) establish a uniform rule and consistent scheme of enforcement and sanctions applicable to all professional tennis events and to all governing bodies.

#### B. Definitions

- 1) "AHO" refers to an Anti-Corruption Hearing Officer.
- 2) "ATP" refers to the ATP Tour, Inc.
- 3) "CAS" refers to the Court of Arbitration for Sport.
- 4) "Consideration" refers to anything of value except for money.
- 5) "Corruption Offense" refers to any offense described in Article D or E of this Program.
- 6) "Covered Person" refers to any player, Related Person, or Tournament Support Personnel.
- 7) "Decision" refers to a decision of an AHO regarding the commission of a Corruption Offense.
- 8) "Demand" refers to a written demand for information issued by the TIU to any Covered Person.
- 9) "Director" refers to the director of the TIU.
- 10) "Event" refers to all professional tennis matches and other tennis competitions, whether men's or women's, which are organized, sanctioned or recognized by any of the Governing Bodies.
- 11) "Governing Bodies" refers to the ATP, the ITF, the WTA and the GSC.
- 12) "GSC" refers to the Grand Slam committee.
- 13) "Hearing" refers to a hearing before an AHO in accordance with Article G of this Program.
- 14) "Information in the public domain" refers to information which has been published or is a matter of public record or can be readily acquired by an interested member of the public and/or information which has been disclosed according to the rules or regulations governing a particular event.
- 15) "Inside Information" refers to information about the likely participation or likely performance of a player in an event or concerning the weather, court conditions, status, outcome or any other aspect of an event which is known by a Covered Person and is not information in the public domain.
- 16) "ITF" refers to the International Tennis Federation.
- 17) "Notice" refers to written notice sent by the PTIO to a Covered Person alleged to have committed a Corruption Offense.



## VIII. THE CODE

- 18) "Player" refers to any player who enters or participates in any competition, event or activity organized or sanctioned by any Governing Body.
- 19) "Program" refers to this Uniform Tennis Anti-Corruption Program.
- 20) "PTIO" refers to the Professional Tennis Integrity Officer appointed by each Governing Body.
- 21) "Related Person" refers to any coach, physiotherapist, therapist, physician, management representative, agent, family member, tournament guest, business associate or other affiliate or associate of any player, or any other person who receives accreditation at an event at the request of the player or any other Related Person.
- 22) "TIB" refers to the Tennis Integrity Board.
- 23) "TIU" refers to the Tennis Integrity Unit.
- 24) "Tournament Support Personnel" refers to any tournament director, owner, operator, employee, agent, contractor or any similarly situated person at any Event and any other person who receives accreditation at an Event at the request of Tournament Support Personnel.
- 25) "Wager" refers to a wager of money or Consideration or any other form of financial speculation.
- 26) "WTA" refers to the WTA Tour, Inc.

### C. Covered Players, Persons and events

- 1) All Players, Related Persons, and Tournament Support Personnel shall be bound by and shall comply with all of the provisions of this Program and shall be deemed to accept all terms set out herein.
- 2) It is the responsibility of each Player, Related Person and Tournament Support Personnel to acquaint himself or herself with all of the provisions of this Program. Further, each Player shall have a duty to inform Related Persons with whom they are connected of all of the provisions of this Program and shall instruct Related Persons to comply with the Program.

### D. Offenses

Commission of any offense set forth in Article D or E of this Program including a violation of the Reporting Obligations or any other violation of the provisions of this Program shall constitute a Corruption Offense for all purposes of this Program.

#### 1) Corruption Offenses.

- a) No Covered Person shall, directly or indirectly, wager or attempt to wager on the outcome or any other aspect of any event or any other tennis competition.
- b) No Covered Person shall, directly or indirectly, solicit or facilitate any other person to wager on the outcome or any other aspect of any Event or any other tennis competition. For the avoidance of doubt, to solicit or facilitate to wager shall include, but not be limited to: display of live tennis betting odds on a Covered Person website; writing articles for a tennis betting publication or website; conducting personal appearances for a tennis betting company; and appearing in commercials encouraging others to bet on tennis.

## VIII. THE CODE

- c) No Covered Person shall, directly or indirectly, solicit or accept any money, benefit or Consideration for the provision of an accreditation to an Event (i) for the purpose of facilitating a commission of a Corruption Offense; or (ii) which leads, directly or indirectly, to the commission of a Corruption Offense.
- d) No Covered Person shall, directly or indirectly, contrive or attempt to contrive the outcome or any other aspect of any event.
- e) No Covered Person shall, directly or indirectly, solicit or facilitate any player to not use his or her best efforts in any event.
- f) No Covered Person shall, directly or indirectly, solicit or accept any money, benefit or Consideration with the intention of negatively influencing a player's best efforts in any event.
- g) No Covered Person shall, directly or indirectly, offer or provide any money, benefit or Consideration to any other Covered Person with the intention of negatively influencing a player's best efforts in any event.
- h) No Covered Person shall, directly or indirectly, solicit or accept any money, benefit or Consideration, for the provision of any Inside Information.
- i) No Covered Person shall, directly or indirectly, offer or provide any money, benefit or Consideration to any other Covered Person for the provision of any Inside Information.
- j) No Covered Person shall, directly or indirectly, offer or provide any money, benefit or Consideration to any Tournament Support Personnel in exchange for any information or benefit relating to a tournament.
- k) No Covered Person may be employed or otherwise engaged by a company which accepts wagers on Events.

### 2) Reporting Obligation.

#### a) Players.

- i) In the event any Player is approached by any person who offers or provides any type of money, benefit or consideration to a Player to (i) influence the outcome or any other aspect of any event, or (ii) provide Inside Information, it shall be the Player's obligation to report such incident to the TIU as soon as possible.
- ii) In the event any Player knows or suspects that any other Covered Person or other individual has committed a Corruption Offense, it shall be the Player's obligation to report such knowledge or suspicion to the TIU as soon as possible.
- iii) If any Player knows or suspects that any Covered Person has been involved in an incident described in Article D.2.b. below, a player shall be obligated to report such knowledge or suspicion to the TIU as soon as possible.
- iv) A Player shall have a continuing obligation to report any new knowledge or suspicion regarding any Corruption Offense, even if the Player's prior knowledge or suspicion has already been reported.

#### b) Related Persons and Tournament Support Personnel.

- i) In the event any Related Person or Tournament Support Person is approached by any person who offers or provides any type of money, benefit or Consideration to a Related Person or Tournament Support Person to (i) influence or attempt to influence the outcome of any aspect of any event, or (ii) provide Inside Information, it shall be the Related Person's or Tournament Support Person's obligation to report such incident to the TIU as soon as possible.

## VIII. THE CODE

- ii) In the event any Related Person or Tournament Support Person knows or suspects that any Covered Person or other individual has committed a Corruption Offense, it shall be the Related Person's or Tournament Support Person's obligation to report such knowledge or suspicion to the TIU as soon as possible.
- c) For the avoidance of doubt, (i) a failure of the Reporting Obligation by any Covered Person; and/or (ii) a failure of the duty to cooperate under Section F.2, shall constitute a Corruption Offense for all purposes of the Program.

### E. Additional Matters

- 1) Each player shall be responsible for any Corruption Offense committed by any Covered Person if such player either (i) had knowledge of a Corruption Offense and failed to report such knowledge pursuant to the reporting obligations set forth in section D.2. above or (ii) assisted the commission of a Corruption Offense. In such event, the AHO shall have the right to impose sanctions on the player to the same extent as if the player had committed the Corruption Offense.
- 2) For a Corruption Offense to be committed, it is sufficient that an offer or solicitation was made, regardless of whether any money, benefit or Consideration was actually paid or received.
- 3) Evidence of a player's lack of efforts or poor performance during an event may be offered to support allegations that a Covered Person committed a Corruption Offense, but the absence of such evidence shall not preclude a Covered Person from being sanctioned for a Corruption Offense.
- 4) A valid defense may be made to a charge of a Corruption Offense if the person alleged to have committed the Corruption Offense (a) promptly reports such conduct to the TIU and (b) demonstrates that such conduct was the result of an honest and reasonable belief that there was a significant threat to the life or safety of such person or any member of such person's family.

### F. Investigation and Procedure

#### 1) Anti-Corruption Hearing Officer.

- a) The TIB shall appoint one or more independent AHO's, who shall be responsible for (i) determining whether Corruption Offenses have been committed, and (ii) fixing the sanctions for any Corruption Offense found to have been committed.
- b) An AHO shall serve a term of two years, which may thereafter be renewed at the discretion of the TIB. If an AHO becomes unable to serve, a new AHO may be appointed for a full two-year term pursuant to this provision.

#### 2) Investigations.

- a) The TIU shall have the right to conduct an initial interview and follow-up interviews, if necessary as determined solely by the TIU, with any Covered Person in furtherance of investigating the possibility of a commission of a Corruption Offense.
  - i) The date and time of all interviews shall be determined by the TIU, giving reasonable allowances for Covered Persons' tournament and travel schedules.
  - ii) The Covered Person shall have the right to have counsel attend the interview(s).

## VIII. THE CODE

- iii) The interview shall be recorded. The recorded interviews shall be used for transcription and evidentiary purposes and thereafter shall be retained by the TIU for a minimum of 3 years in a secure place.
- iv) The Covered Person shall have the right to request an interpreter, and the cost shall be borne by the TIU.
- v) Transcripts of the interview shall be provided to the Covered Person, upon request, within a reasonable period of time following the conclusion of the interview.
- b) All Covered Persons must cooperate fully with investigations conducted by the TIU including giving evidence at hearings, if requested. No Covered Person shall tamper with or destroy any evidence or other information related to any Corruption Offense.
- c) If the TIU believes that a Covered Person may have committed a Corruption Offense, the TIU may make a Demand to any Covered Person to furnish to the TIU any information regarding the alleged Corruption Offense, including, without limitation, (i) records relating to the alleged Corruption Offense (including, without limitation, itemized telephone billing statements, text of SMS messages received and sent, banking statements, Internet service records, computers, hard drives and other electronic information storage devices), and (ii) a written statement setting forth the facts and circumstances with respect to the alleged Corruption Offense. The Covered Person shall furnish such information within seven business days of the making of such Demand, or within such other time as may be set by the TIU. Any information furnished to the TIU shall be (i) kept confidential except when it becomes necessary to disclose such information in furtherance of the prosecution of a Corruption Offense, or when such information is reported to administrative, professional, or judicial authorities pursuant to an investigation or prosecution of non sporting laws or regulations and (ii) used solely for the purposes of the investigation and prosecution of a Corruption Offense.
- d) By participating in any event, or accepting accreditation at any event, a Covered Person contractually agrees to waive and forfeit any rights, defenses, and privileges provided by any law in any jurisdiction to withhold information requested by the TIU or the AHO. If a Covered Person fails to produce such information, the AHO may rule a player ineligible to compete, and deny a Covered Person credentials and access to events, pending compliance with the Demand.
- e) If a PTIO concludes that a Corruption Offense may have been committed, the PTIO shall refer the matter and send the evidence to the AHO, and the matter shall proceed to a hearing before the AHO in accordance with Article G of this Program.
- 3) Each Covered Person shall be determined to be immediately contactable at the most current postal address provided to a Governing Body. Any Notice delivered hereunder to a Covered Person at such address, shall be deemed to have been received by the Covered Person on date of delivery to such address in the confirmation of delivery provided by the courier service company. At its discretion, as an alternative to or in conjunction with the courier delivery, any other method of secure and confidential communication may be used, including, but not limited to hand delivery, facsimile or e-mail, provided that the burden of proving receipt via such alternative methods shall be on the sending party.

## VIII. THE CODE

### G. Due Process

#### 1) Commencement of Proceedings.

- a) When the PTIO refers a matter to the AHO pursuant to Article F.2.e, the PTIO shall send a Notice to each Covered Person alleged to have committed a Corruption Offense, with a copy to the AHO, setting out the following:
  - i) the Corruption Offense(s) alleged to have been committed, including the specific Article(s) of this Program alleged to have been infringed;
  - ii) the facts upon which such allegations are based;
  - iii) the potential sanctions prescribed under this Program for such Corruption Offense(s); and
  - iv) the Covered Person's entitlement to have the matter determined by the AHO at a hearing.
- b) The Notice shall also specify that, if the Covered Person wishes to dispute the PTIO's allegations, the Covered Person must submit a written request to the AHO for a Hearing so that it is received as soon as possible, but in any event within fourteen business days of the date of the receipt of Notice as defined in Article F.3.
- c) A Covered Person shall direct any response to a Notice to the AHO with a copy to the PTIO and may respond in one of the following ways:
  - i) To admit the Corruption Offense and accede to the imposition of sanctions, in which case no hearing shall be conducted and the AHO shall promptly issue a Decision confirming the commission of the Corruption Offense(s) alleged in the Notice and ordering the imposition of sanctions, which shall be determined by the AHO after requesting and giving due consideration to a written submission from the PTIO on the recommended sanction.
  - ii) To deny the Corruption Offense and to have the AHO determine the charge, and if the charge is upheld, the sanctions, at a hearing conducted in accordance with Section G.2.
  - iii) To admit that he or she has committed the Corruption Offense(s) specified in the Notice, but to dispute and/or seek to mitigate the sanctions specified in the Notice. Either a request for hearing or a written submission solely on the issue of the sanction must be submitted simultaneously with the Covered Person's response to the Notice. If a hearing is requested, it shall be conducted in accordance with Section G.2. If no hearing is requested, the AHO shall promptly issue a Decision confirming the commission of the Corruption Offense(s) specified in the Notice and ordering the imposition of sanctions, after giving due consideration to the Covered Person's written submission (if any) and any response submitted by the PTIO.
- d) If the Covered Person fails to file a written request for a hearing by the deadline set out in Section G. 1. b, he or she shall be deemed:
  - i) to have waived his or her entitlement to a hearing;
  - ii) to have admitted that he or she has committed the Corruption Offense(s) specified in the Notice;
  - iii) to have acceded to the potential sanctions specified in the Notice; and,
  - iv) the AHO shall promptly issue a Decision confirming the commission of the Corruption Offense(s) alleged in the Notice and ordering the imposi-

## VIII. THE CODE

- tion of sanctions, after requesting and giving due consideration to a written submission from the PTIO on the recommended sanction.
- e) If, for any reason, the AHO is or becomes unwilling or unable to hear the case, then the AHO may request that the TIB appoint a substitute or successor AHO for such matter in accordance with Article F.1.
  - f) In the event a Covered Person requests a hearing under Section G.1.c.ii or G.2.c.iii, thereafter, but no more than twenty business days after the date of the Notice or request for hearing if received, the AHO shall convene a meeting or telephone conference with the PTIO and/or, its legal representatives, the Covered Person to whom the Notice was sent and his or her legal representatives (if any), to take jurisdiction formally over the matter and to address any pre-hearing issues. The non-attendance of the Covered Person or his or her representatives at the meeting, after proper notice of the meeting has been provided, shall not prevent the AHO from proceeding with the meeting in the absence of the Covered Person, whether or not any written submissions are made on behalf of the Covered Person. In the meeting the AHO shall:
    - i) determine the date(s) (which must be at least twenty business days after the meeting, unless the parties consent to a shorter period) upon which the hearing shall be held. Subject to the foregoing sentence, the hearing shall be commenced as soon as practicable after the Notice is sent, and ordinarily within sixty days of the date that the Covered Person requests a hearing. The hearing shall be completed expeditiously;
    - ii) establish dates reasonably in advance of the date of the hearing at which:
      - aa) The Covered Person shall submit a brief with argument on all issues that he or she wishes to raise at the hearing;
      - bb) The PTIO shall submit an answering brief, addressing the arguments of the Covered Person and setting out argument on the issues that the PTIO wishes to raise at the hearing;
      - cc) The Covered Person may submit a reply brief, responding to the PTIO's answer brief; and
      - dd) The Covered Person and the PTIO shall exchange witness lists (with each witness's address, telephone number and a summary of the subject areas of the witness's anticipated testimony) and copies of the exhibits that they intend to introduce at the hearing; and
    - iii) make such order as the AHO shall deem appropriate in relation to the production of relevant documents or other materials between the parties.
  - g) The AHO may, at any time prior to issuing a Decision, request that an additional investigation be conducted into any matter reasonably related to the alleged Corruption Offense. If the AHO requests such an additional investigation, the TIU shall conduct the investigation in accordance with the AHO's directions and shall report the findings of that investigation to the AHO and the Covered Person implicated in the alleged Corruption Offense at least ten days prior to the hearing. If the Covered Person wishes to object to, or raise any issues in connection with, such additional investigation, he or she may do so by written submission to the AHO.
- #### 2) Conduct of Hearings.
- a) Hearings shall be conducted on a confidential basis. Unless the AHO orders otherwise for good cause shown by a party, each Hearing shall take place in either Miami, Florida, USA or London, England, as determined by the AHO.

## VIII. THE CODE

- b) The Covered Person shall have the right (i) to be present and to be heard at the Hearing and (ii) to be represented at the Hearing, at his or her expense, by legal counsel. The Covered Person may choose not to appear at the Hearing, but rather to provide a written submission for consideration by the AHO, in which case the AHO shall take such submission into account in making his or her Decision. However, the non-attendance of the Covered Person or his or her representative at the Hearing, after proper notice of the Hearing has been provided, shall not prevent the AHO from proceeding with the Hearing in his or her absence, whether or not any written submissions are made on his or her behalf.
  - c) The procedures followed at the Hearing shall be at the discretion of the AHO, provided that the Hearing shall be conducted in a fair manner with a reasonable opportunity for each party to present evidence (including the right to call and to question witnesses), address the AHO and present his, her or its case.
  - d) The PTIO shall make arrangements to have the Hearing recorded or transcribed at the PTIO's expense. If requested by the Covered Person, the PTIO shall also arrange for an interpreter to attend the Hearing, at the PTIO's expense.
  - e) Witness testimony presented in person or by video conference is acceptable.
  - f) The TIB as well as PTIO members shall be permitted to attend all hearings, in person or by audio or video conference.
- 3) Burdens and Standards of Proof.**
- a) The PTIO (which may be represented by legal counsel at the hearing) shall have the burden of establishing that a Corruption Offense has been committed. The standard of proof shall be whether the PTIO has established the commission of the alleged Corruption Offense by a preponderance of the evidence.
  - b) Where this Program places the burden of proof upon the Covered Person alleged to have committed a Corruption Offense to rebut a presumption or establish facts or circumstances, the standard of proof shall be by a preponderance of the evidence.
  - c) The AHO shall not be bound by any jurisdiction's judicial rules governing the admissibility of evidence. Instead, facts relating to a Corruption Offense may be established by any reliable means, as determined in the sole discretion of the AHO.
- 4) Decisions.**
- a) Once the parties have made their submissions, the AHO shall determine whether a Corruption Offense has been committed. Where Article H of this Program specifies a range of possible sanctions for the Corruption Offense found to have been committed, the AHO shall also fix the sanction within that range, after considering any submissions on the subject that the parties may wish to make.
  - b) The AHO shall issue a Decision in writing as soon as possible after the conclusion of the hearing. Such Decision will be sent to the parties and shall set out and explain:
    - i) the AHO's findings as to what Corruption Offenses, if any, have been committed;
    - ii) the sanctions applicable, if any, as a result of such findings; and
    - iii) the rights of appeal applicable pursuant to Article I of this Program.

## VIII. THE CODE

- c) The TIU shall pay all costs and expenses of the AHO and of staging the hearing. The AHO shall not have the power to award costs or make any costs order against a Covered Person or the PTIO. Each party shall bear its own costs, legal, expert and otherwise.
- d) Subject only to the rights of appeal under Article I of this Program, the AHO's Decision shall be the full, final and complete disposition of the matter and will be binding on all parties. If the AHO determines that a Corruption Offense has been committed, the TIB will publicly report the Decision.

### H. Sanctions

- 1) The penalty for any Corruption Offense shall be determined by the AHO in accordance with the procedures set forth in Article G, and may include:
  - a) With respect to any player, (i) a fine of up to \$250,000 plus an amount equal to the value of any winnings or other amounts received by such Covered Person in connection with any Corruption Offense, (ii) ineligibility for participation in any event organized or sanctioned by any Governing Body for a period of up to three years, and (iii) with respect to any violation of Section D.1, clauses (d)-(j) and Section D.2, ineligibility for participation in any event organized or sanctioned by any Governing Body for a maximum period of permanent ineligibility.
  - b) With respect to any Related Person or Tournament Support Person, (i) a fine of up to \$250,000 plus an amount equal to the value of any winnings or other amounts received by such Covered Person in connection with any Corruption Offense; (ii) suspension of credentials and access to any event organized, sanctioned or recognized by any Governing Body for a period of not less than one year, and (iii) with respect to any violation of clauses (c)-(i) of Article D.1., suspension of credentials and access to any event organized, sanctioned or recognized by any Governing Body for a maximum period of permanent revocation of such credentials and access.
  - c) No player who has been declared ineligible may, during the period of ineligibility, participate in any capacity in any event (other than authorized anti-gambling or anti-corruption education or rehabilitation programs) organized or sanctioned by any Governing Body. Without limiting the generality of the foregoing, such player shall not be given accreditation for, or otherwise granted access to, any competition or event to which access is controlled by any Governing Body, nor shall the player be credited with any points for any competition played during the period of ineligibility.
- 2) The TIU may report information regarding an investigation to the TIB and the PTIO's at any time.
- 3) The TIB may report Corruption Offenses that also violate non-sporting laws and regulations to the competent administrative, professional or judicial authorities.
- 4) If any Covered Person commits a Corruption Offense under this program during a period of ineligibility, it shall be treated as a separate Corruption Offense under this Program.

### I. Appeals

- 1) Any Decision (i) that a Corruption Offense has been committed, (ii) that no Corruption Offense has been committed, (iii) imposing sanctions for a Corruption Offense, or (iv) that the AHO lacks jurisdiction to rule on an alleged Corruption Offense or its

## VIII. THE CODE

sanctions, may be appealed exclusively to CAS in accordance with CAS's Code of Sports-Related Arbitration and the special provisions applicable to the Appeal Arbitration Proceedings, by either the Covered Person who is the subject of the Decision being appealed, or the TIB.

- 2) Any Decision appealed to CAS shall remain in effect while under appeal unless CAS orders otherwise.
- 3) The deadline for filing an appeal with CAS shall be twenty business days from the date of receipt of the Decision by the appealing party.
- 4) The decision of CAS shall be final, non-reviewable, non-appealable and enforceable. No claim, arbitration, lawsuit or litigation concerning the dispute shall be brought in any other court or tribunal.

### J. Conditions of Reinstatement

- 1) Once a Covered Person's period of ineligibility or suspension has expired and the covered Person has paid all fines and/or prize money forfeitures, the Covered Person will become automatically eligible and no application by the Covered Person for reinstatement will be necessary.
- 2) All fines and/or prize money forfeitures imposed on players hereunder must be paid within thirty (30) days following the later of the receipt of an AHO decision or, if appealed to CAS, the receipt of the CAS decision. If not paid within the prescribed timeframe, the player shall be ineligible for participation in any event organized or sanctioned by any Governing Body until such time as the fine and/or prize money forfeitures have been paid in full. The AHO and the PTIO shall have the discretion to establish an installment plan for payment of any fines and/or prize money forfeitures. For the avoidance of doubt, the schedule of payments pursuant to such plan may extend beyond any period of ineligibility; however, a default in payment under such plan shall automatically trigger a period of ineligibility until such default is cured.

### K. General

- 1) No action may be commenced under this Program against any Covered Person for any Corruption Offense unless such action is commenced within either (i) eight years from the date that the Corruption Offense allegedly occurred or (ii) two years after the discovery of such alleged Corruption Offense, whichever is later.
- 2) Section headings within this Program are for the purpose of guidance only and do not form part of the Program itself. Nor do they inform or affect the language of the provisions to which they refer.
- 3) This Program shall be governed in all respects (including, but not limited to, matters concerning the arbitrability of disputes) by the laws of the State of Florida, without reference to conflict of laws principles.
- 4) In the event any provision of this Program is determined invalid or unenforceable, the remaining provisions shall not be affected. This Program shall not fail because any part of this Program is held invalid.
- 5) Except as otherwise stated herein, failure to exercise or enforce any right conferred by the Program shall not be deemed to be a waiver of any such right nor operate so as to bar the exercise or enforcement thereof or of any other right on any other occasion.

## VIII. THE CODE

- 6) This Program is applicable prospectively to Corruption Offenses occurring on or after the date that this Program becomes effective. Corruption Offenses occurring before the effective date of this Program are governed by the former rules of the Governing Bodies which were applicable on the date that such Corruption Offense occurred.
- 7) Except as otherwise agreed to by the parties, all filings, Decisions, hearings and appeals shall be issued or conducted in English. 8.06 Final Dispute Resolution

### 8.06 Final Dispute Resolution

- A. Any dispute between or among the ATP, its Tournaments or its players (with the exception of any dispute relating to or arising out of a change in tournament class membership status) arising out of the application of any provision of this Rulebook which is not finally resolved by applicable provisions of the Rulebook shall be submitted exclusively to the Court of Arbitration for Sport ("CAS") for final and binding arbitration in accordance with CAS's Code of Sports-Related Arbitration. The decision of CAS in that arbitration shall be final, non-reviewable, non-appealable and enforceable. No claim, arbitration, lawsuit or litigation concerning the dispute shall be brought in any other court or tribunal. Any request for CAS arbitration shall be filed with CAS within 21 days of any action by the ATP which is the subject of the dispute.
- B. In the event any provision of this rule is determined invalid or unenforceable, the remaining provisions shall not be affected. This rule shall not fail because any part of the rule is held invalid.

## **IX. ATP RANKINGS ®**

### **9.01 Definitions**

- A.** The 2012 ATP Doubles Team Rankings is the mathematical method of ranking men's doubles pairs on a calendar-year basis.
- B.** The South African Airways ATP Rankings (singles) and the ATP Doubles Rankings are the objective merit-based method used for determining qualification for entry and seeding in all tournaments for both singles and doubles, except as modified for the ATP World Tour Team Championship and Barclays ATP World Tour Finals (singles or doubles).
- C.** The South African Airways ATP Rankings (singles) and ATP Doubles Rankings are run approximately 45 times per year.
- D.** Every player who has earned South African Airways ATP Rankings (singles) or ATP Doubles Rankings points in an eligible professional tournament during the entry ranking period is included in the South African Airways ATP Rankings (singles) or ATP Doubles Rankings.
- E.** The South African Airways ATP Rankings (singles) or ATP Doubles Rankings period is the immediate past 52 weeks, except for:
- \* Barclays ATP World Tour Finals, singles and doubles, which is dropped on the Monday following the last ATP World Tour event of the following year.
  - \* Futures Series tournaments that are only entered into the system on the second Monday following the tournament's week.
- Once entered, all tournaments, except for the Barclays ATP World Tour Finals, remain in the system for 52 consecutive weeks.

### **9.02 Eligibility**

Unless otherwise approved by the ATP, South African Airways ATP Rankings (singles) and ATP Doubles Rankings points are awarded to all tournaments or series of tournaments that meet the following criteria. (An event seeking an exception must petition the ATP in writing at least 90 days in advance of the tournament.):

- A.** Prize money must be a minimum of \$35,000 plus hospitality, except for Futures, which shall be a minimum of \$10,000 per event. Futures tournaments must be scheduled in a minimum of three (3) consecutive weeks of \$10,000 each or two (2) consecutive weeks of \$15,000 each in prize money.
- B.** Prize money must be paid in a manner consistent with the breakdowns approved by the ATP.
- C.** Selection of direct acceptances shall be determined according to the South African Airways ATP Rankings (singles and/or ATP Doubles Rankings). The South African Airways ATP Rankings (singles) and ATP Doubles Rankings lists utilized shall not be more than 42 days prior to the start of the tournament.

## IX. ATP RANKINGS

- D. The minimum size for a draw is 28 singles players and 16 doubles teams unless otherwise approved by the ATP.
- E. The composition of the draws shall be consistent with the ATP rules. Tournaments are required to provide hotel accommodation consistent with ATP rules.
- F. Unless otherwise approved by the ATP, South African Airways ATP Rankings points (singles and doubles) are only awarded to Grand Slam and ATP World Tour tournaments that meet the above criteria.

### 9.03 South African Airways ATP Rankings (Singles)

**A. Commitment Players.** The year-end South African Airways ATP Rankings (singles) is based on calculating, for each player, his total points from the four (4) Grand Slams, the eight (8) mandatory ATP World Tour Masters 1000 tournaments and the Barclays ATP World Tour Finals of the ranking period, and his best six (6) results from all ATP World Tour 500, ATP World Tour 250, ATP Challenger Tour and Futures tournaments. For every Grand Slam or mandatory ATP World Tour Masters 1000 tournament for which a player is not in the main draw, and was not (and, in the case of a Grand Slam, would not have been, had he and all other players entered) a main draw direct acceptance on the original acceptance list, and never became a main draw direct acceptance, the number of his results from all other eligible tournaments in the ranking period, that count for his ranking, is increased by one (1). In weeks where there are not four (4) Grand Slams and eight (8) ATP World Tour Masters 1000 tournaments in the ranking period, the number of a player's best results from all eligible tournaments in the ranking period will be adjusted accordingly. Once a player is accepted in the main draw of one of these twelve (12) tournaments, as a direct acceptance, a qualifier, a special exempt or a lucky loser, or having accepted a wild card, his result in this tournament shall count for his ranking, whether or not he participates.

**B. Non-commitment Players.** The South African Airways ATP Rankings (singles) is based on calculating, for each player, his total points from the four (4) Grand Slams, the eight (8) mandatory ATP World Tour Masters 1000 tournaments and the Barclays ATP World Tour Finals of the ranking period, and his best six (6) results from all ATP World Tour 500, ATP World Tour 250, ATP Challenger Tour and Futures tournaments. For every Grand Slam or mandatory ATP World Tour Masters 1000 tournament for which a player is not in the main draw, and was not (and, in the case of a Grand Slam, would not have been, had he and all other players entered) a main draw direct acceptance on the original acceptance list, and never became a main draw direct acceptance, the number of his results from all other eligible tournaments in the ranking period, that count for his ranking, is increased by one (1). In weeks where there are not four (4) Grand Slams and eight (8) ATP World Tour Masters 1000 tournaments in the ranking period, the number of a player's best results from all eligible tournaments in the ranking period will be adjusted accordingly. Once a player is accepted in the main draw of one of these twelve (12) tournaments, as a direct acceptance, a qualifier, a special exempt or a lucky loser, or having accepted a wild card, his result in this tournament shall count for his ranking, whether or not he participates.

**C. ATP World Tour 500 – Ranking Penalty.** A player's (Commitment and Non-Commitment players) withdrawal from an ATP World Tour 500 event whether on time or after the 12 noon deadline, shall result in a zero (0) point ranking penalty. Further non-

## IX. ATP RANKINGS

consecutive withdrawals shall result in a zero (0) point allocation replacing the next best positive result for each additional withdrawal. Players with multiple consecutive withdrawals who are out of competition for 30 days or longer due to injury will not be subject to a ranking penalty as long as verified and approved medical forms are provided; or, a player shall not have the ranking penalty imposed if he completes the Promotional Activities requirement as specified under "Repeal of Withdrawal Fines and/or Penalties" or if the on-site withdrawal procedures apply. Players may also appeal withdrawal penalties to a Tribunal who will determine whether the penalties are affirmed or set aside. A player who has received a zero (0) point ranking penalty for withdrawing from an ATP World Tour 500 event may replace the zero (0) point by playing an additional ATP World Tour 500 event in that same calendar year for a total of four (4) played. The replacement tournament must be after the 500 withdrawal that has resulted in a ranking penalty. Only one (1) additional ATP World Tour 500 event per year may be used to replace an ATP World Tour 500 ranking penalty.

- D. Loser points for the rounds achieved are awarded to players in any tournament not completed.
- E. Ties.** When two or more players have the same total number of points, ties shall be broken as follows:
- 1) the most total points from the Grand Slams, ATP World Tour Masters 1000 mandatory tournaments and Barclays ATP World Tour Finals main draws, and if still tied, then,
  - 2) the fewest events played, counting all missed Grand Slams, ATP World Tour Masters 1000 tournaments and Barclays ATP World Tour Finals they could have played (as described under A. above) as if played, and if still tied, then,
  - 3) the highest number of points from one single tournament, then, if needed, the second highest, and so on.

### F. Entry Protection

- 1) **Petition.** A player may petition the President, or his designee, for an entry protection when he is physically injured and does not compete in any tennis event, including Special Events – Exhibitions, for a minimum period of six (6) months. The written petition must be received within six (6) months after his last tournament.
- 2) **Calculation and Use.** The entry protection shall be a position in the South African Airways ATP Rankings (singles), as determined by the player's average South African Airways ATP Rankings (singles) position during the first three (3) months of his injury. The entry protection shall be for entry into the main draw or qualifying competition or for special exempt consideration. The entry protection shall not be used for seeding purposes or lucky loser consideration.
- 3) **Limit of Use.**
  - a) If a player is physically injured and does not compete in any tennis event for a period of at least six (6) months but less than twelve (12) months, the entry protection shall be in effect for either the first nine (9) tournaments that the player competes in using the entry protection (excluding wild cards and entries as a direct acceptance with his current position in the ATP Ranking) or for the period up to nine (9) months beginning with the first tennis event, in-

## IX. ATP RANKINGS

cluding Special Events – Exhibitions, that the player competes in, whichever occurs first.

- b)** If a player is physically injured and does not compete in any tennis event for a period of twelve (12) months or longer, the entry protection shall be in effect for either the first twelve (12) tournaments that the player competes in using the entry protection (excluding wild cards and entries as a direct acceptance with his current position in the ATP Ranking) or for the period up to twelve (12) months beginning with the first tennis event, including Special Events – Exhibitions, that the player competes in, whichever occurs first.
- 4) Expiration Date.** A player has three (3) years from the time that the injury occurred to activate his protected ranking. A player who does not compete in any tennis event, including Special Events – Exhibitions, for a period of three (3) years from the date of his injury will have his entry protection revoked.
- 5) Re-injury Protection.** A player who has returned to competition using his protected ranking and re-injures himself may petition for a “freeze” of the nine (9) or twelve (12) month limit for competing using his protected ranking. To be eligible for the “freeze” the player must be out of competition for a minimum of three (3) months. Upon the player’s return to competition he shall have the same number of events and weeks remaining as were available when the “freeze” went into effect. A maximum of two (2) “freezes” are allowed during the nine (9) or twelve (12) month period.

**Note:** For purposes of this rule, three (3) months is calculated at thirteen (13) weeks; six (6) months is calculated at twenty-six (26) weeks; nine (9) months is calculated at thirty-nine (39) weeks; and twelve (12) months is calculated at fifty-two (52) weeks.

### G. Points.

- Points shall be allocated based on tournament category (Grand Slam, Barclays ATP World Tour Finals, ATP World Tour Masters 1000, ATP World Tour 500, ATP World Tour 250, Davis Cup, World Team Championship, ATP Challenger Tour and Futures Series).
- Points are assigned to the losers of the round indicated. Any player who reaches the second round by drawing a bye and then loses shall be considered to have lost in the first round and shall receive first round loser’s points. Wild cards at Grand Slams and ATP World Tour Masters 1000 events receive points only from the 2nd round. No points are awarded for a first round loss at ATP World Tour 500 & 250 events, ATP Challenger Tour or Futures Series events.
- Players qualifying for the main draw through the qualifying competition shall receive qualifying points in addition to any points earned, as per the following table, with the exception of Futures.
- In addition to the points allocated as per the following table, points shall be allocated to losers at Grand Slam, ATP World Tour Masters 1000, ATP World Tour

## IX. ATP RANKINGS

500 and ATP World Tour 250 tournaments qualifying events, as follows:

Grand Slams	16 points for a last round loss 8 points for a second round loss
ATP World Tour Masters 1000	16 points for a last round loss 0 points for a first round loss (*)
ATP World Tour 500	10 points for a last round loss 0 points for a first round loss (**)
ATP World Tour 250	6 points for a last round loss 0 points for a first and second round loss

\* 8 points only if the main draw is larger than 56

\*\* 4 points only if the main draw is larger than 32

\*\*\* 3 points only if the main draw is larger than 32

<b>5) Point table.</b>	<b>W</b>	<b>E</b>	<b>SE</b>	<b>QE</b>	<b>R16</b>	<b>R32</b>	<b>R64</b>	<b>R128</b>	<b>Q</b>
Grand Slams	2000	1200	720	360	180	90	45	10	25
Barclays ATP World Tour Finals	*1500								
ATP World Tour Masters 1000	1000	600	360	180	90	45	<sup>10</sup> (25)	(10)	<sup>11</sup> 25
ATP World Tour 500	500	300	180	90	45	(20)			<sup>12</sup> 20
ATP World Tour 250	250	150	90	45	20	(10)			<sup>13</sup> 12
ATP Challenger Tour 125,000 + H	125	75	45	25	10				
ATP Challenger Tour 125,000	110	65	40	20	9				
ATP Challenger Tour 100,000	100	60	35	18	8				
ATP Challenger Tour 75,000	90	55	33	17	8				
ATP Challenger Tour 50,000	80	48	29	15	7				
ATP Challenger Tour 35,000 + H	80	48	29	15	6				
Futures** 15,000 + H	35	20	10	4	1				
Futures** 15,000	27	15	8	3	1				
Futures** 10,000 +H	27	15	8	3	1				
Futures** 10,000	18	10	6	2	1				

\* ATP World Tour Finals 1,500 for undefeated Champion (200 for each round robin match win, plus 400 for a semi-final win, plus 500 for the final win)

\*\* ATP Doubles Rankings points will be awarded in Futures tournaments beginning with the semi-final round.

(1) 16 points only if the main draw is larger than 56

(2) 10 points only if the main draw is larger than 32

(3) 5 points only if the main draw is larger than 32



## IX. ATP RANKINGS

### 9.04 ARAG ATP World Team Championship Point Schedule

	1st	2nd	3rd		Cumulative	**Bonus	Total
<u>Singles</u>	<u>Round</u>	<u>Round</u>	<u>Round</u>	<u>Finals*</u>	<u>Points</u>	<u>Points</u>	<u>Points</u>
Singles 1	35	35	35	95	200	50	250
Singles 2	25	25	25	50	125	50	175
<u>Doubles</u>							
Deciding Match	35	35	35	95	200	50	250
Dead Rubber	10	10	10	20	50		50

#### Bonus Points:

- \* Players who only play the finals will be awarded points from the previous round.
- \*\* Players must win all 4 matches and be part of the winning team in order to earn the Bonus Points.

### 9.05 Davis Cup

#### A. Point Table

Points per Live Singles Match Played

	Per Match		Team	Performance		Wins
	<u>Match</u>	<u>Won</u>	<u>Bonus*</u>	<u>Bonus**</u>	<u>Cumulative</u>	
Playoff Round	1	5				
Playoff Round	2	10				
First Round*	1	40				40
First Round*	2	40				80
Quarter-Final	3	65				145
Quarter-Final	4	65				210
Semi-Final	5	70				280
Semi-Final	6	70				350
Finals	7	75	75**			500
Finals	8	75		125***		625

- \* Participation: For the first round only, any player who competes in a "live" singles match(es), without a win, shall receive 10 ranking points.
- \*\* Team bonus awarded to player who wins 7 live matches in a calendar year and his team wins the competition.
- \*\*\* Individual player bonus to player who wins 8 live matches in a calendar year.

#### B. Points per Doubles Match Played

- \* Participation: For the first round only, the team who competes in the doubles match, and loses, shall receive 10 ranking points.

## IX. ATP RANKINGS

- \*\* Team bonus awarded to doubles team who wins 4 matches in a calendar year and his team wins the competition.

	Per Match	Team	Wins
	<u>Won</u>	<u>Bonus**</u>	<u>Cumulative</u>
Playoff Round	10		50
First Round*	50		130
Quarter-Final	80		220
Semi-Final	90		315
Finals	95	35	350

#### C. Special Ranking Rules for Davis Cup

- 1) If a player does not compete in the singles of one or more rounds he will receive points from the previous round when playing singles at the next tie.
- 2) If a player does not compete in singles in either the 1st round or Quarter-final round and then plays singles in the Semi-final and Final rounds, he will receive Quarter-final points for his Semi-final match, but will then be eligible for Finals points when playing the final.
- 3) If a player is a late substitution to the team and was released from another tournament that same week, he will not be eligible to earn points for that Davis Cup tie. A player only has the opportunity to earn points in one event per week.
- 4) If a particular Davis Cup round shows up twice within the 52-week window, the best one of those two results will count towards the player's Davis Cup result. (This will come into play when a tie is played earlier in the year compared to the previous year and both ties fall within the 52-week window.)
- 5) For doubles, 1-3 above also apply to the team as it applies to the 2012 ATP Doubles Team Rankings.
  - a) Team Bonus only applies if the doubles team is unchanged and wins all four matches and the team wins the competition.
  - b) The individual's doubles points will be based on that player's participation in each of the rounds.

### 9.06 ATP Doubles Rankings

A. The ATP Doubles Rankings is based on calculating, for each player, his total points from his best 18 results from all eligible tournaments, including the Barclays ATP World Tour Finals (Doubles) played in the Ranking period. For entry purposes there are no mandatory events, however, once a player is accepted in the main draw of any of the four (4) Grand Slams or the (8) ATP World Tour Masters 1000, as a direct acceptance, a qualifier or a lucky loser or having accepted a wild card, his result in one of these twelve (12) tournaments, shall count for his ranking, whether or not he participates.

B. Loser points for the rounds achieved are awarded to players in any tournament not completed.

C. **Ties.** When two or more players have the same total number of points, ties shall be broken as follows:

## IX. ATP RANKINGS

- 1) the fewest events played, and if still tied, then,
- 2) the most total points from the Grand Slams, ATP World Tour Masters 1000 mandatory tournaments and the Barclays ATP World Tour Finals (Doubles), and if still tied, then
- 3) the highest number of points from one single tournament, then, if needed, the second highest, etc.

**Note:** The method for breaking ties on site, between teams, is described under Selections of Entries.

**D. Entry Protection.** The Entry Protection, as described above for the South African Airways ATP Rankings (singles), applies for doubles under the same provisions.

**E. Points.** The provisions set forth under E.1), 2) and 3) related to the South African Airways ATP Rankings (singles) apply to doubles as well, the point table being similar, except that the second-round loser column becomes irrelevant. No points are awarded in the first round at any event. Should a doubles match in an ATP World Tour or ATP Challenger Tour event be uncontested or fail to be completed, the losing team shall only receive points and prize money from the previous round unless one of the following is applicable:

- a) Neither player was in the singles main draw.
- b) The retiring/withdrawing player is still in the singles competition and at the time of the medical examination is declared unfit to play in the singles of that event or, if no longer involved in the singles competition of that event, is forced to withdraw from the singles or doubles\* of the next tournament in which he is entered.

\* **For ATP Challenger events the withdrawal for doubles must be after the withdrawal deadline.**

- c) The withdrawing player had retired/withdrawn from his singles match, which was scheduled the same day.
  - i) A team withdrawing from the first round will not receive prize money even if there is not an alternate team.

**Case:** *Player A retires / withdraws from the doubles for medical reasons. Player A is also in the singles draw but is not scheduled to play his next match until the next day. On the day of his scheduled singles match Player A withdraws from the singles and receives medical documentation from the Tournament Doctor declaring him unfit for competition. The medical condition is the same condition that caused the doubles retirement / withdrawal.*

**Decision:** *In this case the doubles team shall receive points / prize money from the round reached.*

**Case:** *Player A withdraws from the singles competition due to food poisoning, he is in the doubles competition but is not scheduled to play doubles until the next day. Player A would like to withdraw from the doubles immediately, however the tournament doctor says he cannot declare him unfit for play for a match scheduled the following day.*

**Decision:** *If Player A withdraws from the doubles without a medical from the tournament doctor declaring him unfit for play then the*

## IX. ATP RANKINGS

*team receives ranking points / prize money from the previous round.*

**Note:** *In cases where the condition of the player is likely to improve in a short time period the tournament doctor should examine the player on the day of the match to determine his status and if he feels the player is fit for competition.*

### 9.07 2012 ATP Doubles Team Rankings

**A.** Each team is ranked according to its total points from its best 18 results from all eligible tournaments (Grand Slam, ATP World Tour, including the Barclays ATP World Tour Finals) played in the calendar year.

**B.** Loser points for the rounds achieved are awarded to players in any tournament not completed.

**C. Ties.** Ties between two or more teams having the same total number of points shall be broken using the same methods as for breaking ties between players in the ATP Doubles Rankings.

**D. Points.** The provisions set forth under 9.06 E. above, including a), b) and c), apply as well when calculating the ATP Doubles Team Rankings.

### 9.08 Retiring from the Professional Tennis Circuit

Any player wishing to retire from the professional tennis circuit must submit a written notice to the Chief Player Officer of the ATP in order to have his name removed from the South African Airways ATP Rankings.

## X. EXHIBITS

### EXHIBIT A.01 - ATP World Tour Official Tournament Stamps



### EXHIBIT A.02 - Size Relationship - Men Only Events



Size Relationship: Tournament Logo  
MUST be a minimum of 60% of the surface area of the tournament logo



Size Relationship: Tournament Title  
MUST be a minimum of 60% of the surface area of the tournament title

## X. EXHIBITS

### EXHIBIT A.03 - Size Relationship - Combined Events



Size Relationship: Sony Ericsson WTA Tour Logo  
MUST be the same visual size (cover the same surface area)



Size Relationship: Tournament Logo  
MUST be at a minimum, equal size to the Sony Ericsson WTA logo or 30% of the surface area of the tournament logo, whichever is greater



Size Relationship: Tournament Title  
MUST be at a minimum, equal size to the Sony Ericsson WTA logo or 30% of the surface area of the tournament title, whichever is greater

## X. EXHIBITS

### EXHIBIT A.04 - Positioning

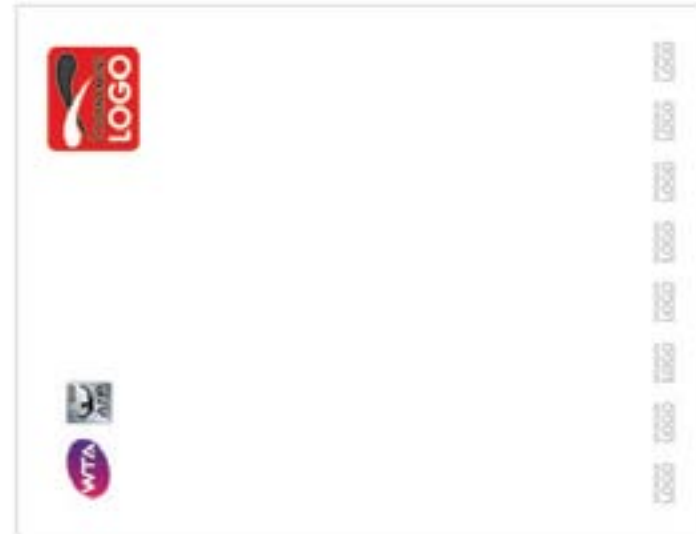

MUST be placed closest to the tournament logo or tournament title, away from sponsor logos. NEVER add to sponsor logo strips

## X. EXHIBITS

### EXHIBIT A.05 - Exclusion Area

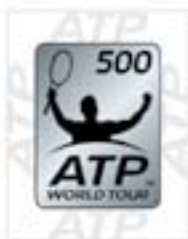

Exclusion Area 1 = height of the ATP type  
For graphics, images, text, Sony Ericsson WTA Tour and tournament logos (including presenting sponsor)



Exclusion Area 2 = 2x width of the Official Tournament Stamp  
For sponsor, federation and series logos or any other brand mark

## X. EXHIBITS

### EXHIBIT A.06.1 - Acceptable & Unacceptable Uses - Men only



**DO**  
place the ATP World Tour Official Tournament Stamp closest to the tournament logo. Ensure it is at least 60% of the surface area of the tournament logo and is positioned away from sponsor logos, federation names or any other brand mark



**DO**  
place the ATP World Tour Official Tournament Stamp closest to the tournament title when it is used larger than, or in place of the tournament logo. Ensure it is at least 60% of the surface area of the tournament title and is positioned away from sponsor logos, federation names or any other brand mark

## X. EXHIBITS

### EXHIBIT A.06.2 - Acceptable & Unacceptable Uses - Men only



**DO NOT**  
apply rules to the smallest tournament logo or tournament title on the page



**DO NOT**  
make the ATP World Tour Official Tournament Stamp smaller than 60% of the tournament logo or tournament title



**DO NOT**  
omit the ATP World Tour Official Tournament Stamp when using a tournament title in place of a tournament logo



**DO NOT**  
apply rules to the smallest tournament logo or tournament title when both are used on a page. The 60% rule applies to the greater of the two

## X. EXHIBITS

### EXHIBIT A.06.3 - Acceptable & Unacceptable Uses - Men only



**DO NOT**  
place sponsor logos closest to the tournament logo or tournament title



**DO NOT**  
place the ATP World Tour Official Tournament Stamp alongside sponsor logos or add it to sponsor logo strips



**DO NOT**  
make the ATP World Tour Official Tournament Stamp smaller than 60% of the surface area of the tournament logo or tournament title



**DO NOT**  
break the exclusion area for sponsor logos

## X. EXHIBITS

### EXHIBIT A.06.4 - Acceptable & Unacceptable Uses - Combined

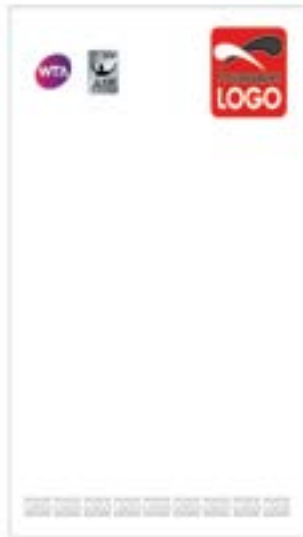

**DO**  
place the ATP World Tour Official Tournament Stamp closest to the tournament logo. The ATP World Tour Official Tournament Stamp must be at a minimum, equal size to the Sony Ericsson WTA logo or 30% of the surface area of the tournament logo, whichever is greater. Position away from sponsor logos, federation names or any other brand mark



**DO**  
place the ATP World Tour Official Tournament Stamp closest to the tournament title when it is used larger than, or in place of, the tournament logo. The ATP World Tour Official Tournament Stamp must be at a minimum, equal size to the Sony Ericsson WTA logo or 30% of the surface area of the tournament title, whichever is greater. Position away from sponsor logos, federation names or any other brand mark

## X. EXHIBITS

### EXHIBIT A.06.5 - Acceptable & Unacceptable Uses - Combined

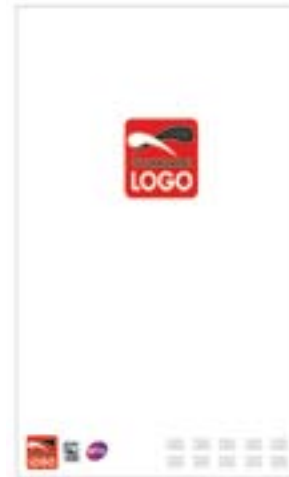

**DO NOT**  
apply rules to the smallest tournament logo or tournament title on the page.

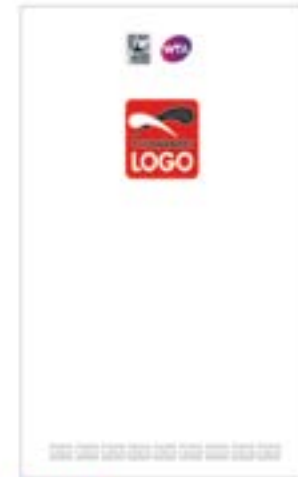

**DO NOT**  
make the ATP World Tour Official Tournament Stamp smaller than 30% of the surface area of the tournament logo.



**DO NOT**  
omit the ATP World Tour Official Tournament Stamp when using a tournament title in place of a tournament logo.



**DO NOT**  
apply rules to the smallest tournament logo or tournament title when both are used on the page. 30% rule applies to the greater of the two.

## X. EXHIBITS

### EXHIBIT A.06.6 - Acceptable & Unacceptable Uses - Combined



**DO NOT**  
place the ATP World Tour Official Tournament Stamp alongside sponsor logos or add it to sponsor logo strips.



**DO NOT**  
make the Sony Ericsson WTA Tour logo visually larger than the ATP World Tour Official Tournament Stamp. DO NOT place sponsor logos closer to the tournament logo or tournament title.

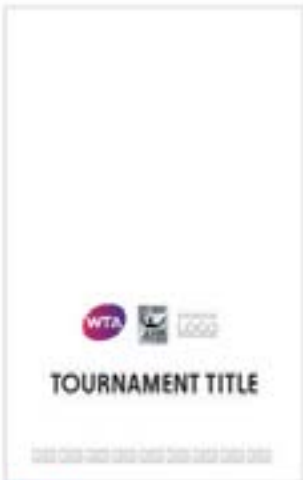

**DO NOT**  
break the exclusion area for sponsor logos.



**DO NOT**  
make size of the ATP World Tour Official Tournament Stamp smaller than 30% of the surface area of the tournament logo or tournament title.

## X. EXHIBITS

### EXHIBIT A.07 - Web Site Exhibit



### EXHIBIT A.08 - Scoreboards / Draw Boards





# X. EXHIBITS

## EXHIBIT A.09 - Leader Boards

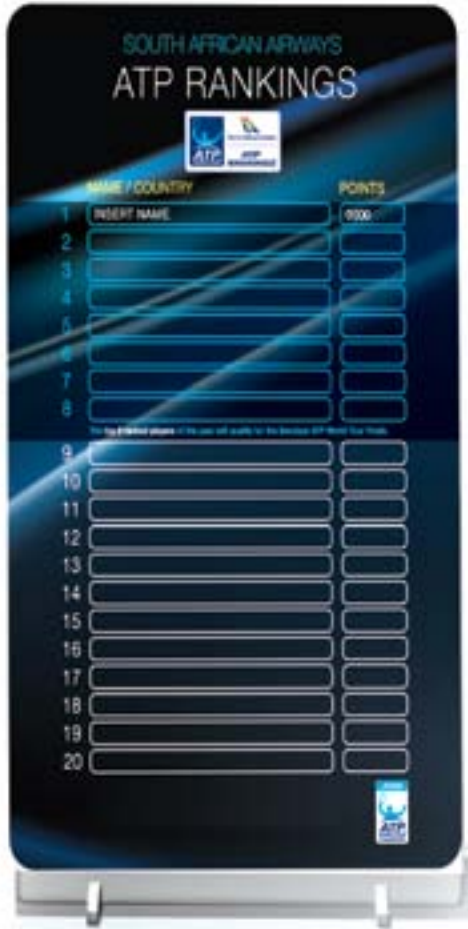

# X. EXHIBITS

## EXHIBIT A.10 - Nets / Net Signage

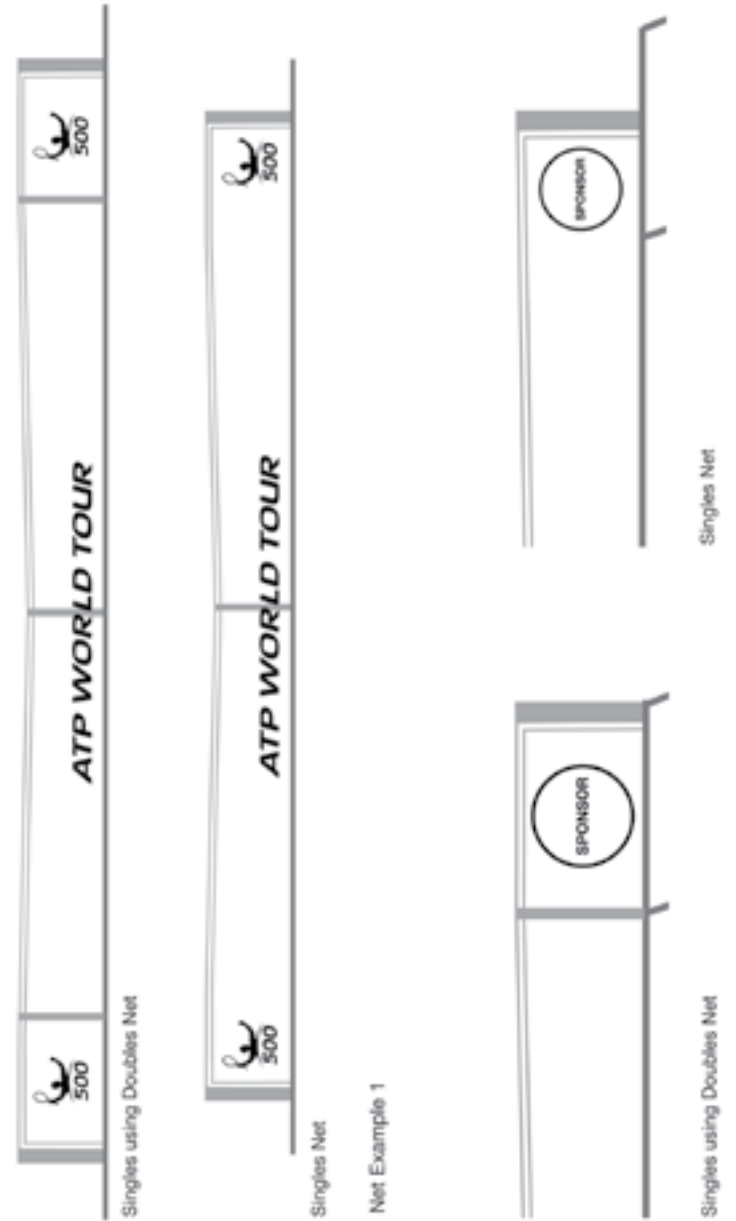

# X. EXHIBITS

EXHIBIT A.11 - Media Backdrop



# X. EXHIBITS

EXHIBIT A.12 - Court Surface Color

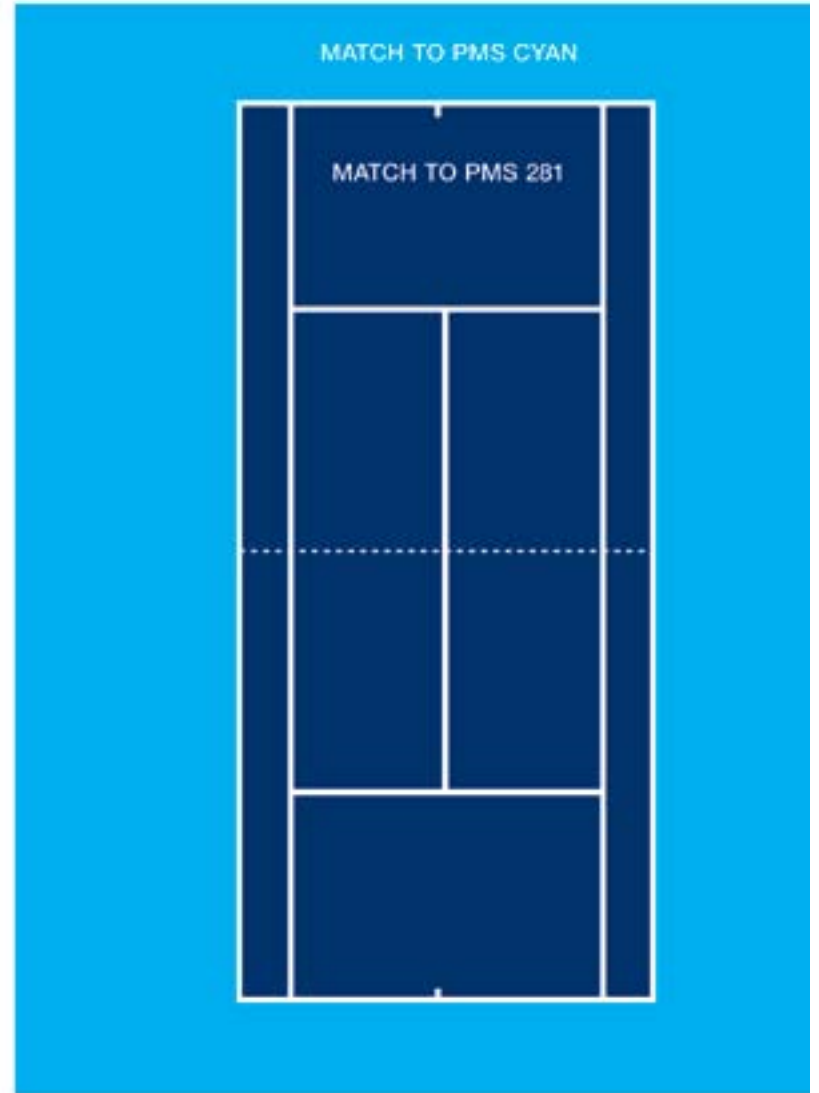

# X. EXHIBITS

## EXHIBIT A.13.1 - Court Host Locality - Option 1

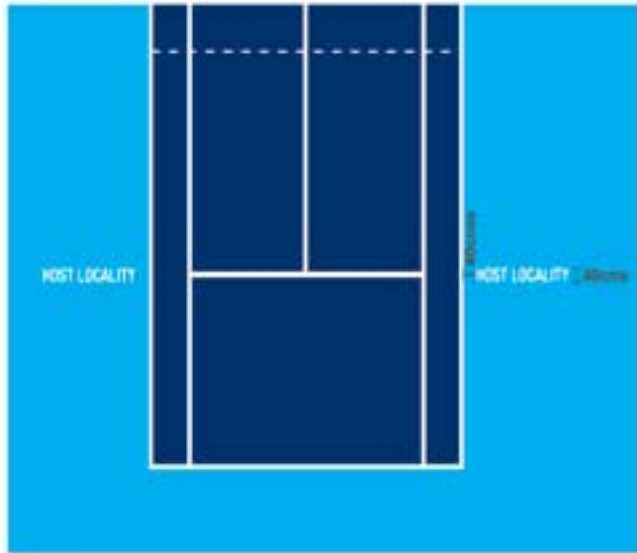

One Line

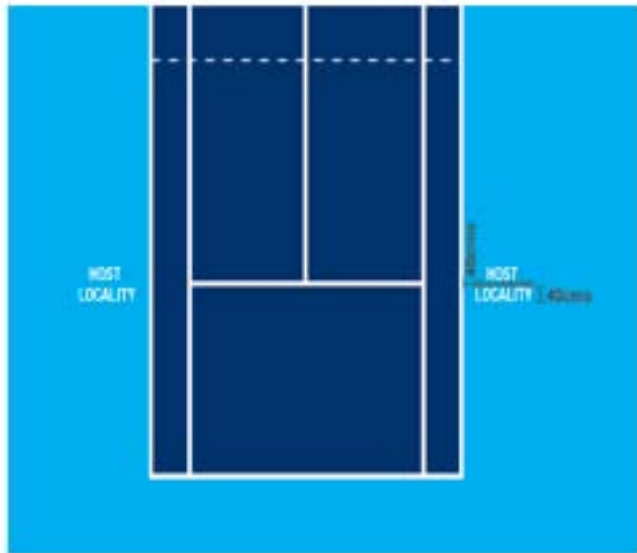

Two Lines

# X. EXHIBITS

## EXHIBIT A.13.2 - Court Host Locality - Option 2

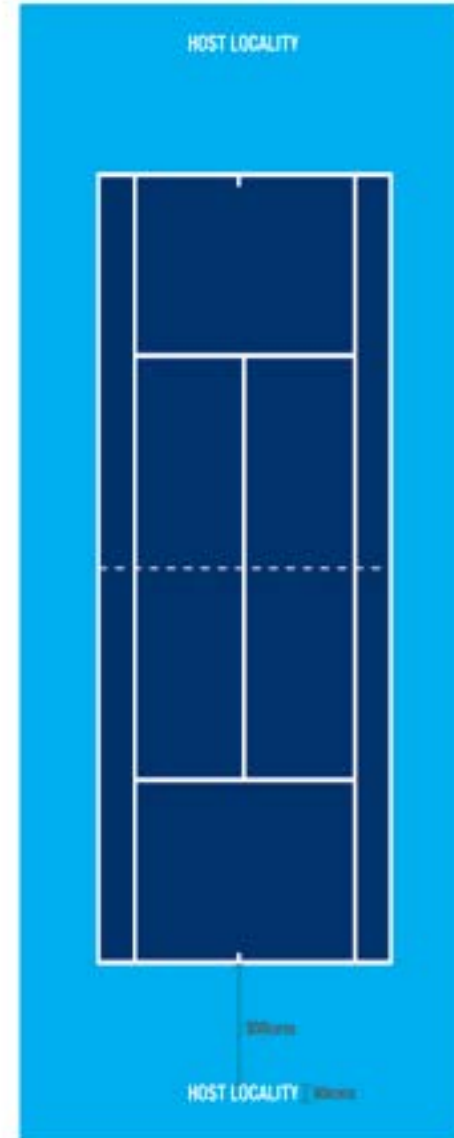

# X. EXHIBITS

## EXHIBIT A.14 - Court Backdrops



# X. EXHIBITS

## EXHIBIT A.15 - ATP Challenger Tour Brand Mark



## EXHIBIT A.16 - ATP Challenger Tour Website



## X. EXHIBITS

### EXHIBIT A.17 - ATP Challenger Tour Court Backdrops



## X. EXHIBITS

### EXHIBIT B - ATP World Tour Logo

#### ATP World Tour Trademark and Logo (Terms and Conditions)

In addition to Exhibit A, the following are the terms and conditions for the use of any ATP World Tour trademark or logo (collectively referred to herein as the "ATP Logo"). Only ATP World Tour tournaments referred to in CIRCUIT REGULATIONS shall be permitted to use the ATP Logo. ATP Challenger Tour tournaments are authorized to use only the ATP Challenger Tour Logo (collectively referred to herein as the "Challenger Logo") (see Exhibit A).

- 1) Each tournament acknowledges that ATP has created the ATP Logo and has used the ATP Logo on and in connection with the promotion of the sport of tennis, recreational facilities, tennis videos, sporting goods, clothing, various printed matter, and other officially licensed products and merchandise, and have sought worldwide trademark registration for same and, through the use of the ATP Logo, ATP has developed goodwill associated with the ATP Logo.
- 2) Subject to the terms and conditions set forth herein, ATP hereby authorizes each tournament, by this license, to use the ATP Logo (and the applicable 1,000, 500 or 250 Tournament Stamp) or Challenger Logo, as applicable, in connection with the advertising and promotion of such tournament. This authorization and license shall (i) in the case of each ATP World Tour tournament, be subject to such ATP World Tour tournament remaining a member in good standing of the ATP as well as compliance with the other terms and conditions set forth herein, and (ii) in the case of each ATP sanctioned tournament or event, including ATP Challenger Tour events, be subject to such tournament maintaining its sanction with the ATP in good standing as well as compliance with the other terms and conditions set forth herein. Such license will be limited to written advertising and publicity, such use being for the sole purpose of identifying a tournament as an ATP World Tour or Challenger Tour tournament and will not extend to any use that exploits the ATP Logo or Challenger Logo in any other fashion or to the use of the ATP Logo or Challenger Logo on merchandising or products of any kind without the express written approval of ATP.
- 3) Use of the ATP Logo or Challenger Logo by a tournament shall be restricted to the advertising and promotion of such tournament. The use of the ATP Logo must be approved in advance by ATP.
- 4) The use of the ATP Logo or Challenger Logo by a tournament does not extend to use on merchandise or resold products without the express written approval of ATP, unless obtained through an official ATP licensee.
- 5) However, the ATP Logo or Challenger Logo may be used by a tournament to produce and sell tournament T-shirts and sweatshirts (not collared shirts) with the ATP Logo or Challenger Logo not to exceed four (4) square inches (26 sq. cm.). Express written approval is required from ATP if a tournament wants to produce these items itself. No approval is required if the T-shirts and sweatshirts are obtained from an approved ATP licensee.
- 6) Each tournament hereby acknowledges that ATP owns all rights, title and interest in and to the ATP Logo (and the applicable 1,000, 500 or 250 Tournament Stamp) and Challenger Logo and each tournament agrees it will do nothing inconsistent with such ownership nor attack the ATP's title or interest in and to the ATP Logo

## X. EXHIBITS

or Challenger Logo other than the right to use the ATP Logo or Challenger Logo in accordance with this agreement.

- 7) Each tournament agrees that it will not file a trademark application or otherwise attempt to register the ATP Logo (and the applicable 1,000, 500 or 250 Tournament Stamp) or Challenger Logo, or any trademark or logo that may incorporate the ATP Logo or Challenger Logo, for any goods or services whatsoever. Each tournament shall promptly notify ATP of any infringement of the ATP Logo or Challenger Logo or any act of unfair competition by third parties relating to the ATP Logo or Challenger Logo, whenever such infringement or act shall come to the attention of a tournament.
- 8) Each tournament agrees that all goodwill that is or shall become associated with the ATP Logo or Challenger Logo shall be the sole property of ATP.
- 9) Each tournament agrees to use the ATP Logo or Challenger Logo strictly in compliance with and in observance of any and all applicable laws and strictly in accordance with ATP rules and regulations and guidelines and will take whatever steps are reasonably necessary to fully protect ATP's ownership of the ATP Logo and Challenger Logo, including, without limitation, such legends, markings and notices in connection therewith as may be required by ATP.
- 10) Each tournament agrees that such tennis tournament and related services identified in connection with the ATP Logo and Challenger Logo shall be of the highest quality and shall conform to the high standards and reputation of the ATP. Each tournament acknowledges that the provisions of this paragraph are of the essence of this authorization and license.
- 11) If a tournament shall fail to perform or observe any term, condition, agreement, or covenant in this Exhibit B, ATP shall have the right to automatically terminate this authorization and license forthwith.

## X. EXHIBITS

### EXHIBIT C - Broadcast Standards

#### Broadcast Quality Standards

##### 1) Tape Delay/Repeats

Tournaments may not license to domestic or international broadcasters the right to telecast any portion of any match more than 48 hours after the termination of that match, and not more than (3) times within that 48-hour period, unless written authorization is obtained in advance from ATP. Each repeated telecast during the same day must be scheduled in a different part of the day in the same time zone. In the case of any telecast that is not live, tournaments must ensure that broadcasters provide a continuously visible on-screen legend stating "Tape Delay".

The requirement in the above paragraph shall not apply to telecasts under the following situations.

- a) Less than five (5) minutes of continuous action (including time between points) or less than three (3) minutes of match highlights on any news or highlights program.
- b) If because of rain delay or other unavoidable cessation in play, the scheduled broadcast match is canceled, the 48-hour tape delay restriction will be lifted. Any previously recorded match from the current year's competition or last year's competition can be repeated as "filler" programming.

##### 2) Broadcaster's Responsibilities

Each tournament must incorporate the following terms within their Broadcaster contracts.

- a) Host Broadcaster must supply ATP, or ATP designee with one international dirty Beta SP or Beta CAM tape of the final match. Recordings must be available to the ATP Executive Vice President - Rules & Competition on-site immediately after signing off the air or sent to an ATP office promptly after the tournament.
- b) With respect to any live match scores or related statistical data provided to broadcaster by ATP, or its designee, or collected by broadcaster, such broadcasters shall agree (i) not to onward supply, sublicense or otherwise make such scores and data available to any third party for use not related to the broadcast, and (ii) to restrict their use of such scores and data to use on a contemporaneous basis within their live broadcast of any match; any other use shall be subject to a delay of at least :30 seconds. All tournament agreements with Host Broadcasters must comply with, and shall be subject to, all ATP rules as amended from time to time.

##### 3) Technical Requirements

Each tournament must incorporate the following technical terms within their Host Broadcaster contract. These conditions represent the minimum technical standards necessary to produce a quality broadcast.

## X. EXHIBITS

### Cameras

No less than five (5) cameras must be used on stadium court (and no less than three [3] cameras on other courts)) for an acceptable tennis broadcast.

**Camera 1:** Tripod camera high up in the stands (Center Court line).

**Camera 2:** Tripod camera approximately three (3) rows lower than Camera 1 (Center Court line). (Example 1)

**Cameras 3 and 4:** Camera objective lens height approximately 1.00m (see attached charts for camera positions). Used for player close-ups for cutting into coverage and isos.

These cameras may be positioned on the same or opposite side from where the players sit down.

**Camera 5:** Low angle camera on court behind the baseline usually aligned with sideline (see attached chart, Camera Example 2)

Note: Cameras 1, 2, 3, and 4 need to be on secure tripods with fully rotating camera mounts, and remotely controlled irises.

### Lenses

Lenses for Camera 1 should be 18:1. Lenses for Cameras 2, 3, and 4 should be 50:1.

### Microphones

- 1) Four (4) corner court microphones must be positioned in the corners of the court and adjacent to Cameras 3 and 4.
- 2) At least one (1) microphone must be placed for purposes of picking up sound from the crowd.
- 3) One (1) microphone must be placed on the umpire's chair.

### Television Regulation Regarding Same Day Exclusivity

No tournament Class member shall be permitted to telecast or grant any telecaster the right to telecast, in any country in the territory of Europe, all or any portion of any tennis match on the same day as a tennis match from any ATP event that is being telecast in such country by a telecaster to which the ATP has granted telecast rights, unless (x) such tournament Class member (i) is obligated to grant such rights pursuant to a binding agreement entered into prior to September 4, 1994, and furnished to the General Counsel of the ATP pursuant to the ATP Board's resolution of September 4, 1994, or (ii) has received the written permission of the President, or (y) the telecast right granted by the tournament Class member is to a host broadcaster whose television signal is carried only in the country in which that member's tournament is conducted, subject to such reasonable "spillage" into other countries as may be approved by the President; provided, however, that the foregoing shall not limit the right of any tournament Class member to permit the telecast of up to three (3) minutes in the aggregate of any match in respect of any local, regional, national or international news or sports news programming.

## X. EXHIBITS

### EXAMPLE 1

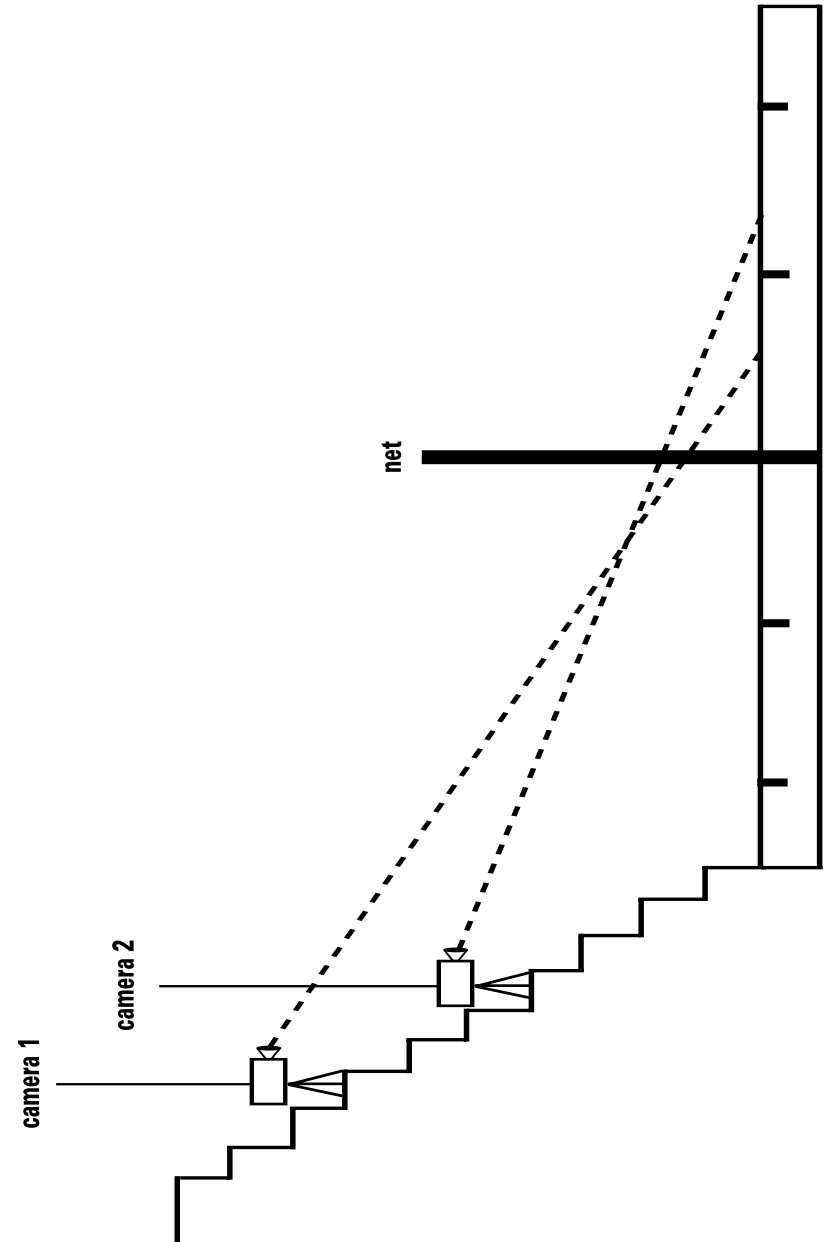

## X. EXHIBITS

### EXAMPLE 2

Standard Camera Positions for Tennis Broadcast

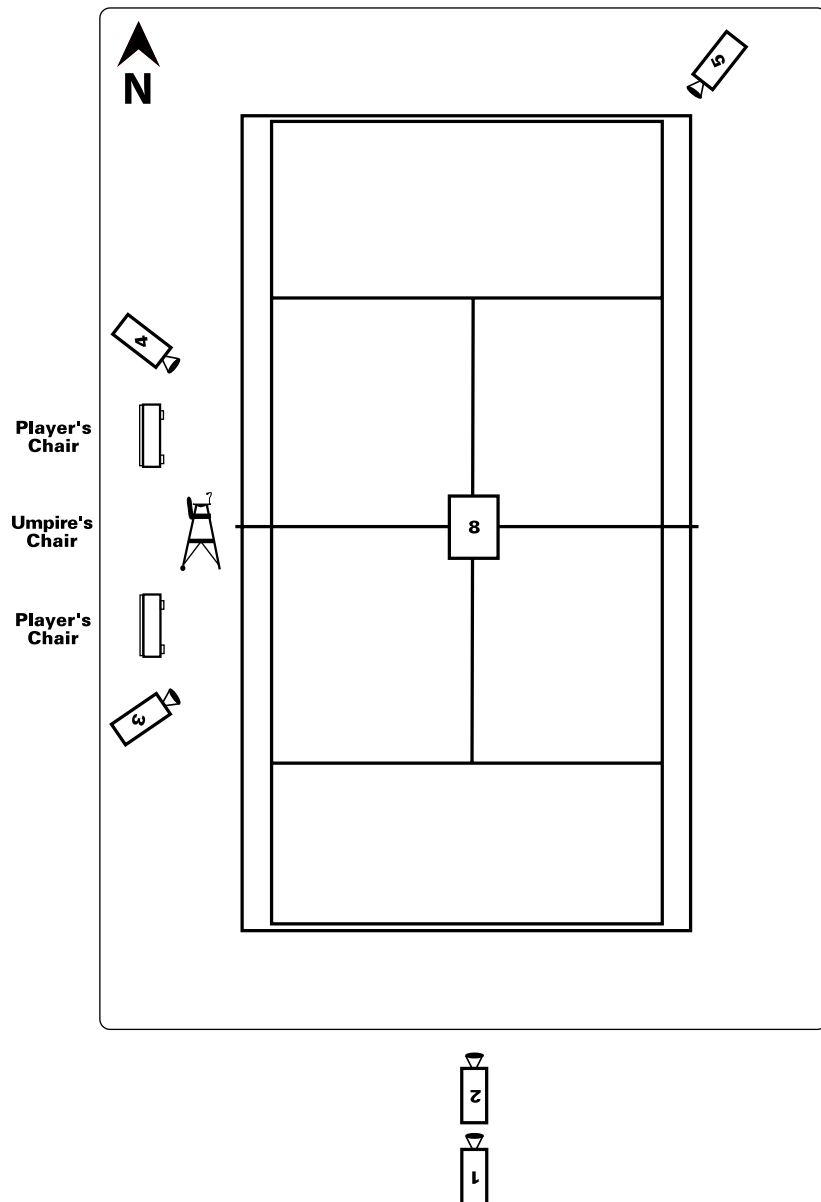

## X. EXHIBITS

### EXHIBIT D - Attendance Standards

#### ATP World Tour Tournament Attendance Quality Standards

Set forth below for each of the tournament classes are two attendance requirements. In each year of operation, each ATP World Tour tournament class member must satisfy both of these requirements. Members failing to satisfy these requirements in any year shall be entitled to seek a waiver of their compliance for that year if compelling external factors outside the member's control, such as consistently bad weather during the tournament week or national emergency, has caused the non-compliance. The waiver must be applied for within 10 days after the conclusion of the tournament and may be granted or denied in the sole discretion of the ATP Board, which, among other things, will consider the member's performance in prior years when the external condition did not occur.

#### 1) Required Attendance

- a) ATP World Tour Masters 1000 Combined tournaments
  - i) Minimum Requirement: 150,000
- b) ATP World Tour Masters 1000 (Indoor & Outdoor) tournaments
  - i) Minimum Requirement: 100,000
- c) ATP World Tour 500 (Indoor & Outdoor) tournaments
  - i) 50,000 or average per session of 75% Stadium Court capacity
- d) ATP World Tour 250 (Indoor & Outdoor) tournaments
  - i) 17,500 (prorated for six (6) day tournaments) or average per session of 75% Stadium Court capacity

#### 2) Minimum Weekend Attendance

The average minimum attendance per session during the final weekend of play must be in excess of 75% of capacity for the Stadium Court.

#### 3) Measurement

- a) Attendance should be measured on the basis of actual spectator attendance at the tournament site during each session, including qualifying sessions.
- b) On a daily basis during the operation of each tournament, each tournament class member shall provide the ATP supervisor with attendance figures in writing on a per session basis for each session held during the prior day. Such report shall set forth both total spectator attendance and the percentage of capacity. Each tournament class member shall promptly provide the ATP supervisor or other member of the ATP staff with any backup necessary to verify its spectator attendance figures if such information is requested.
- c) If the ATP supervisor has any questions concerning the accuracy of such spectator attendance figures based upon his observation of the event, the ATP supervisor shall promptly so notify the tournament class member and shall inform the member of what he believes is a more accurate spectator attendance count. In such circumstance, the burden will be on the tournament class member to persuade the ATP supervisor of the accuracy of its figures. The final report of the ATP supervisor shall be conclusive.



# X. EXHIBITS

## EXHIBIT E - Electronic Insertion

### Electronic Insertion

Each ATP Tournament must comply with the following in order to use electronic insertion technology in telecasts:

- 1) Each telecast of an ATP World Tour tournament using electronically inserted signage must receive the prior approval of the ATP.
- 2) The company and methodology used to produce electronically inserted signage must meet quality and technical standards and be pre-approved by the ATP.
- 3) Electronically inserted signage may be inserted only in existing signage positions on the backdrop.
- 4) Electronically inserted signage may be altered only during changeovers and only when that signage is not being shown on the broadcast.
- 5) Only static logos may be inserted. No moving logos or videos may be inserted.
- 6) Electronically inserted signage must be consistent in color, graphical look and size with the Tournament's other permanent signage.

# X. EXHIBITS

## EXHIBIT F - Lighting

### Lighting Form



Tournament City: \_\_\_\_\_  
 Tournament Number: \_\_\_\_\_

### LIGHTING MEASUREMENTS

Date of Measurement: \_\_\_\_\_  
 Tournament Supervisor: \_\_\_\_\_  
 Site name: \_\_\_\_\_  
 COURT NAME: \_\_\_\_\_

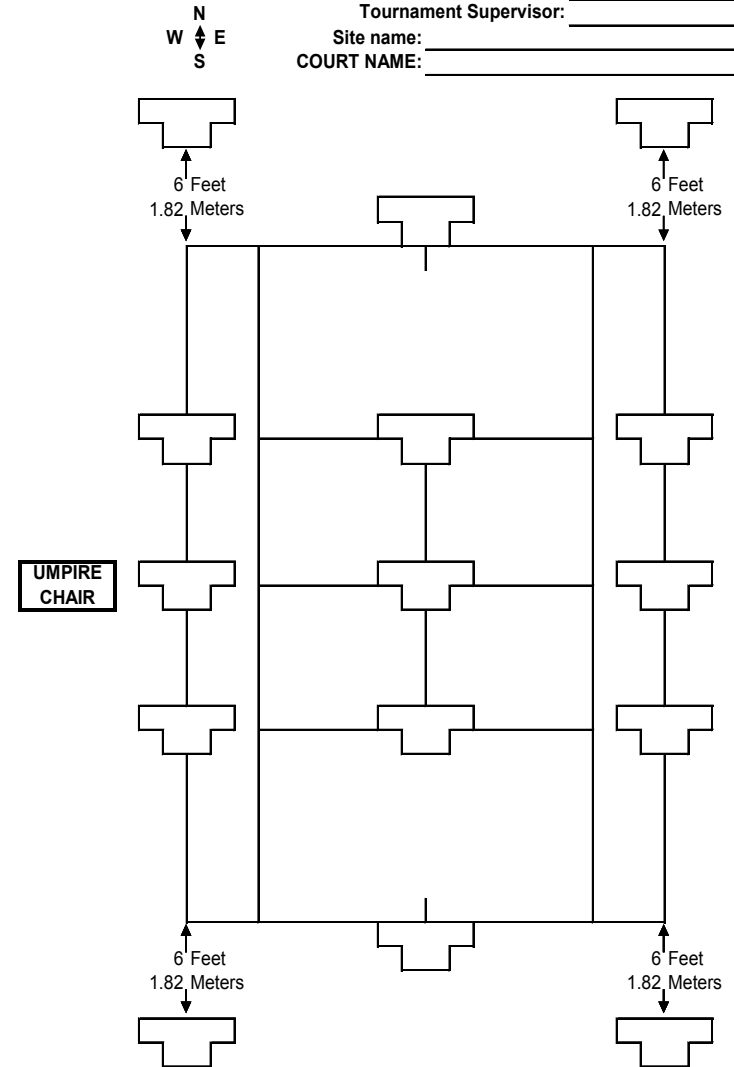

## X. EXHIBITS

### EXHIBIT G - ATP Challenger Tour Logo (Print & Promotional Materials)



#### Basic Guidelines:

- 1) The brand mark should never be modified in any way or redrawn. The three fixed elements (the ATP Challenger Tour logo type; the official ATP logo; the rectangular background field) should never be separated from each other.
- 2) Whenever possible, the ATP Challenger Tour brand mark should be reproduced in color. The one color version is for use only when color restrictions apply.
- 3) The ATP Challenger Tour brand mark should not be used on a background that may make it appear indistinct. It should always appear on an uncluttered background to ensure clarity.
- 4) The ATP Challenger Tour brand mark must be positioned in its own clear space, standing apart from other images, brand marks and/or text. In order to achieve this, the ATP Challenger Tour brand mark should always be surrounded by a minimum clear zone, at least equal in width to the ATP logo in the logotype.
- 5) The ATP Challenger Tour brand mark should not be positioned like a sponsor. It should be separated from sponsor logos in order to stand out as an endorsement of the quality and authenticity of the tournament.

### EXHIBIT H - ATP Challenger Tour Logo (On-Court Version)



ATP Challenger Tour tournaments must only use the on-court version of the logo, shown above, for any signage around the court perimeter.

## X. EXHIBITS

### EXHIBIT I - Rules of Tennis

#### CONTENTS

Rule 1	FOREWORD
Rule 2	THE COURT
Rule 3	PERMANENT FIXTURES
Rule 4	THE BALL
Rule 5	THE RACKET
Rule 6	SCORE IN A GAME
Rule 7	SCORE IN A SET
Rule 8	SCORE IN A MATCH
Rule 9	SERVER & RECEIVER
Rule 10	CHOICE OF ENDS & SERVICE
Rule 11	CHANGE OF ENDS
Rule 12	BALL IN PLAY
Rule 13	BALL TOUCHES A LINE
Rule 14	BALL TOUCHES A PERMANENT FIXTURE
Rule 15	ORDER OF SERVICE
Rule 16	ORDER OF RECEIVING IN DOUBLES
Rule 17	THE SERVICE
Rule 18	SERVING
Rule 19	FOOTFAULT
Rule 20	SERVICE FAULT
Rule 21	SECOND SERVICE
Rule 22	WHEN TO SERVE & RECEIVE
Rule 23	THE LET DURING A SERVICE
Rule 24	THE LET
Rule 25	PLAYER LOSES POINT
Rule 26	A GOOD RETURN
Rule 27	HINDRANCE
Rule 28	CORRECTING ERRORS
Rule 29	ROLE OF COURT OFFICIALS
Rule 30	CONTINUOUS PLAY
	COACHING
	RULES OF WHEELCHAIR TENNIS
	AMENDMENT TO THE RULES OF TENNIS
Appendix I	THE BALL
	CLASSIFICATION OF COURT SURFACE PACE
Appendix II	THE RACKET
Appendix III	ADVERTISING
Appendix IV	ALTERNATIVE PROCEDURES AND SCORING METHODS
Appendix V	ROLE OF COURT OFFICIALS
Appendix VI	OFFICIAL 10 AND UNDER TENNIS COMPETITION
Appendix VII	PROCEDURES FOR REVIEW AND HEARINGS ON THE RULES OF TENNIS
	PLAN OF THE COURT
	SUGGESTIONS ON HOW TO MARK A COURT

References to the International Tennis Federation or ITF shall hereafter mean ITF Limited.

# X. EXHIBITS

## FOREWORD

The International Tennis Federation (ITF) is the governing body of the game of tennis and its duties and responsibilities include determination of the Rules of Tennis.

To assist the ITF in carrying out this responsibility, the ITF has appointed a Rules of Tennis Committee which continually monitors the game and its rules, and when considered necessary makes recommendations for changes to the Board of Directors of the ITF who in turn make recommendations to the Annual General Meeting of the ITF which is the ultimate authority for making any changes to the Rules of Tennis.

Appendix IV lists all known and approved alternative procedures and scoring methods. In addition, on its own behalf or on application by interested parties, certain variations to the rules may be approved by the ITF for trial purposes only at a limited number of tournaments or events and/or for a limited time period. Such variations are not included in the published rules and require a report to the ITF on the conclusion of the approved trial.

Note: Except where otherwise stated, every reference in these Rules of Tennis to the masculine includes the feminine gender.

# X. EXHIBITS

## 1. THE COURT

The court shall be a rectangle, 78 feet (23.77 m) long and, for singles matches, 27 feet (8.23 m) wide. For doubles matches, the court shall be 36 feet (10.97 m) wide.

The court shall be divided across the middle by a net suspended by a cord or metal cable which shall pass over or be attached to two net posts at a height of 3 ½ feet (1.07 m). The net shall be fully extended so that it completely fills the space between the two net posts and it must be of sufficiently small mesh to ensure that a ball cannot pass through it. The height of the net shall be 3 feet (0.914 m) at the centre, where it shall be held down tightly by a strap. A band shall cover the cord or metal cable and the top of the net. The strap and band shall be completely white.

- The maximum diameter of the cord or metal cable shall be 1/3 inch (0.8 cm).
- The maximum width of the strap shall be 2 inches (5 cm).
- The band shall be between 2 inches (5 cm) and 2 ½ inches (6.35 cm) deep on each side.

For doubles matches, the centres of the net posts shall be 3 feet (0.914 m) outside the doubles court on each side.

For singles matches, if a singles net is used, the centres of the net posts shall be 3 feet (0.914 m) outside the singles court on each side. If a doubles net is used, then the net shall be supported, at a height of 3 ½ feet (1.07 m), by two singles sticks, the centres of which shall be 3 feet (0.914 m) outside the singles court on each side.

- The net posts shall not be more than 6 inches (15 cm) square or 6 inches (15 cm) in diameter.
- The singles sticks shall not be more than 3 inches (7.5 cm) square or 3 inches (7.5 cm) in diameter.
- The net posts and singles sticks shall not be more than 1 inch (2.5 cm) above the top of the net cord.

The lines at the ends of the court are called baselines and the lines at the sides of the court are called sidelines.

Two lines shall be drawn between the singles sidelines, 21 feet (6.40 m) from each side of the net, parallel with the net. These lines are called the service lines. On each side of the net, the area between the service line and the net shall be divided into two equal parts, the service courts, by the centre service line. The centre service line shall be drawn parallel with the singles sidelines and half way between them.

Each baseline shall be divided in half by a centre mark, 4 inches (10 cm) in length, which shall be drawn inside the court and parallel with the singles sidelines.

- The centre service line and centre mark shall be 2 inches (5 cm) wide.
- The other lines of the court shall be between 1 inch (2.5 cm) and 2 inches (5 cm) wide, except that the baselines may be up to 4 inches (10 cm) wide.

All court measurements shall be made to the outside of the lines and all lines of the court shall be of the same color clearly contrasting with the color of the surface.

No advertising is allowed on the court, net, strap, band, net posts or singles sticks except as provided in Appendix III.

## X. EXHIBITS

In addition to the court described above, the court designated as “red” and the court designated as “orange” in Appendix VI can be used for 10 and under tennis competition.

**Note:** Guidelines for minimum distances between the baseline and backstops and between the sidelines and sidestops can be found in Appendix VIII.

### 2. PERMANENT FIXTURES

The permanent fixtures of the court include the backstops and sidestops, the spectators, the stands and seats for spectators, all other fixtures around and above the court, the chair umpire, line umpires, net umpire and ball persons when in their recognized positions.

In a singles match played with a doubles net and singles sticks, the net posts and the part of the net outside the singles sticks are permanent fixtures and are not considered as net posts or part of the net.

### 3. THE BALL

Balls, which are approved for play under the Rules of Tennis, must comply with the specifications in Appendix I.

The International Tennis Federation shall rule on the question of whether any ball or prototype complies with Appendix I or is otherwise approved, or not approved, for play. Such ruling may be taken on its own initiative, or upon application by any party with a bona fide interest therein, including any player, equipment manufacturer or National Association or members thereof. Such rulings and applications shall be made in accordance with the applicable Review and Hearing Procedures of the International Tennis Federation (see Appendix VI).

The event organizers must announce in advance of the event:

- a. The number of balls for play (2, 3, 4 or 6).
- b. The ball change policy, if any.

Ball changes, if any, can be made either:

- i) After an agreed odd number of games, in which case, the first ball change in the match shall take place two games earlier than for the rest of the match, to make allowance for the warm-up. A tie-break game counts as one game for the ball change. A ball change shall not take place at the beginning of a tie-break game. In this case, the ball change shall be delayed until the beginning of the second game of the next set; or
- ii. At the beginning of a set

If a ball gets broken during play, the point shall be replayed.

**Case 1:** *If a ball is soft at the end of a point, should the point be replayed?*

**Decision:** *If the ball is soft, not broken, the point shall not be replayed.*

## X. EXHIBITS

**Note:** Any ball to be used in a tournament which is played under the Rules of Tennis, must be named on the official ITF list of approved balls issued by the International Tennis Federation.

### 4. THE RACKET

Rackets, which are approved for play under the Rules of Tennis, must comply with the specifications in Appendix II.

The International Tennis Federation shall rule on the question of whether any racket or prototype complies with Appendix II or is otherwise approved, or not approved, for play. Such ruling may be undertaken on its own initiative, or upon application by any party with a bona fide interest therein, including any player, equipment manufacturer or National Association or members thereof. Such rulings and applications shall be made in accordance with the applicable Review and Hearing Procedures of the International Tennis Federation (see Appendix VI).

**Case 1:** *Is more than one set of strings allowed on the hitting surface of a racket?*

**Decision:** *No. The rule mentions a pattern (not patterns) of crossed strings. (See Appendix II)*

**Case 2:** *Is the stringing pattern of a racket considered to be generally uniform and flat if the strings are on more than one plane?*

**Decision:** *No.*

**Case 3:** *Can vibration damping devices be placed on the strings of a racket? If so, where can they be placed?*

**Decision:** *Yes, but these devices may only be placed outside the pattern of the crossed strings.*

**Case 4:** *During a point, a player accidentally breaks the strings. Can the player continue to play another point with this racket?*

**Decision:** *Yes, except where specifically prohibited by event organizers.*

**Case 5:** *Is a player allowed to use more than one racket at any time during play?*

**Decision:** *No.*

**Case 6:** *Can a battery that affects playing characteristics be incorporated into a racket?*

**Decision:** *No. A battery is prohibited because it is an energy source, as are solar cells and other similar devices.*

### 5. SCORE IN A GAME

- a. Standard game

A standard game is scored as follows with the server's score being called first:

No point	-	“Love”
First point	-	“15”
Second point	-	“30”

## X. EXHIBITS

Third point	-	“40”
Fourth point	-	“Game”

except that if each player/team has won three points, the score is “Deuce”. After “Deuce”, the score is “Advantage” for the player/team who wins the next point. If that same player/team also wins the next point, that player/team wins the “Game”; if the opposing player/team wins the next point, the score is again “Deuce”. A player/team needs to win two consecutive points immediately after “Deuce” to win the “Game”.

### b. Tie-break game

During a tie-break game, points are scored “Zero”, “1”, “2”, “3”, etc. The first player/team to win seven points wins the “Game” and “Set”, provided there is a margin of two points over the opponent(s). If necessary, the tie-break game shall continue until this margin is achieved.

The player whose turn it is to serve shall serve the first point of the tie-break game. The following two points shall be served by the opponent(s) (in doubles, the player of the opposing team due to serve next). After this, each player/team shall serve alternately for two consecutive points until the end of the tie-break game (in doubles, the rotation of service within each team shall continue in the same order as during that set).

The player/team whose turn it was to serve first in the tie-break game shall be the receiver in the first game of the following set.

Additional approved alternative scoring methods can be found in Appendix IV.

## 6. SCORE IN A SET

There are different methods of scoring in a set. The two main methods are the “Advantage Set” and the “Tie-break Set”. Either method may be used provided that the one to be used is announced in advance of the event. If the “Tie-break Set” method is to be used, it must also be announced whether the final set will be played as a “Tie-break Set” or an “Advantage Set”.

### a. “Advantage Set”

The first player/team to win six games wins that “Set”, provided there is a margin of two games over the opponent(s). If necessary, the set shall continue until this margin is achieved.

### b. “Tie-break Set”

The first player/team to win six games wins that “Set”, provided there is a margin of two games over the opponent(s). If the score reaches six games all, a tie-break game shall be played.

Additional approved alternative scoring methods can be found in Appendix IV.

## 7. SCORE IN A MATCH

A match can be played to the best of 3 sets (a player/team needs to win 2 sets to

## X. EXHIBITS

win the match) or to the best of 5 sets (a player/team needs to win 3 sets to win the match).

Additional approved alternative scoring methods can be found in Appendix IV.

## 8. SERVER & RECEIVER

The players/teams shall stand on opposite sides of the net. The server is the player who puts the ball into play for the first point. The receiver is the player who is ready to return the ball served by the server.

*Case 1: Is the receiver allowed to stand outside the lines of the court?*

*Decision: Yes. The receiver may take any position inside or outside the lines on the receiver's side of the net.*

## 9. CHOICE OF ENDS & SERVICE

The choice of ends and the choice to be server or receiver in the first game shall be decided by toss before the warm-up starts. The player/team who wins the toss may choose:

- To be server or receiver in the first game of the match, in which case the opponent(s) shall choose the end of the court for the first game of the match; or
- The end of the court for the first game of the match, in which case the opponent(s) shall choose to be server or receiver for the first game of the match; or
- To require the opponent(s) to make one of the above choices.

*Case 1: Do both players/teams have the right to new choices if the warm-up is stopped and the players leave the court?*

*Decision: Yes. The result of the original toss stands, but new choices may be made by both players/teams.*

## 10. CHANGE OF ENDS

The players shall change ends at the end of the first, third and every subsequent odd game of each set. The players shall also change ends at the end of each set unless the total number of games in that set is even, in which case the players change ends at the end of the first game of the next set.

During a tie-break game, players shall change ends after every six points.

Additional approved alternative procedures can be found in Appendix IV.

## 11. BALL IN PLAY

Unless a fault or a let is called, the ball is in play from the moment the server hits the ball, and remains in play until the point is decided.

## 12. BALL TOUCHES A LINE

If a ball touches a line, it is regarded as touching the court bounded by that line.

## X. EXHIBITS

### 13. BALL TOUCHES A PERMANENT FIXTURE

If the ball in play touches a permanent fixture after it has hit the correct court, the player who hit the ball wins the point. If the ball in play touches a permanent fixture before it hits the ground, the player who hit the ball loses the point.

### 14. ORDER OF SERVICE

At the end of each standard game, the receiver shall become the server and the server shall become the receiver for the next game.

In doubles, the team due to serve in the first game of each set shall decide which player shall serve for that game. Similarly, before the second game starts, their opponents shall decide which player shall serve for that game. The partner of the player who served in the first game shall serve in the third game and the partner of the player who served in the second game shall serve in the fourth game. This rotation shall continue until the end of the set.

### 15. ORDER OF RECEIVING IN DOUBLES

The team which is due to receive in the first game of a set shall decide which player shall receive the first point in the game. Similarly, before the second game starts, their opponents shall decide which player shall receive the first point of that game. The player who was the receiver's partner for the first point of the game shall receive the second point and this rotation shall continue until the end of the game and the set.

After the receiver has returned the ball, either player in a team can hit the ball.

**Case 1:** *Is one member of a doubles team allowed to play alone against the opponents?*

**Decision:** No.

### 16. THE SERVICE

Immediately before starting the service motion, the server shall stand at rest with both feet behind (i.e. further from the net than) the baseline and within the imaginary extensions of the centre mark and the sideline.

The server shall then release the ball by hand in any direction and hit the ball with the racket before the ball hits the ground. The service motion is completed at the moment that the player's racket hits or misses the ball. A player who is able to use only one arm may use the racket for the release of the ball.

### 17. SERVING

When serving in a standard game, the server shall stand behind alternate halves of the court, starting from the right half of the court in every game.

In a tie-break game, the service shall be served from behind alternate halves of the court, with the first served from the right half of the court.

## X. EXHIBITS

The service shall pass over the net and hit the service court diagonally opposite, before the receiver returns it.

### 18. FOOT FAULT

During the service motion, the server shall not:

- a. Change position by walking or running, although slight movements of the feet are permitted; or
- b. Touch the baseline or the court with either foot; or
- c. Touch the area outside the imaginary extension of the sideline with either foot; or
- d. Touch the imaginary extension of the centre mark with either foot.

If the server breaks this rule it is a "Foot Fault".

**Case 1:** *In a singles match, is the server allowed to serve standing behind the part of the baseline between the singles sideline and the doubles sideline?*

**Decision:** No.

**Case 2:** *Is the server allowed to have one or both feet off the ground?*

**Decision:** Yes.

### 19. SERVICE FAULT

The service is a fault if:

- a. The server breaks rules 16, 17 or 18; or
- b. The server misses the ball when trying to hit it; or
- c. The ball served touches a permanent fixture, singles stick or net post before it hits the ground; or
- d. The ball served touches the server or server's partner, or anything the server or server's partner is wearing or carrying.

**Case 1:** *After tossing a ball to serve, the server decides not to hit it and catches it instead. Is this a fault?*

**Decision:** No. *A player, who tosses the ball and then decides not to hit it, is allowed to catch the ball with the hand or the racket, or to let the ball bounce.*

**Case 2:** *During a singles match played on a court with net posts and singles sticks, the ball served hits a singles stick and then hits the correct service court. Is this a fault?*

**Decision:** Yes.

### 20. SECOND SERVICE

If the first service is a fault, the server shall serve again without delay from behind the same half of the court from which that fault was served, unless the service was from the wrong half.

## X. EXHIBITS

### 21. WHEN TO SERVE & RECEIVE

The server shall not serve until the receiver is ready. However, the receiver shall play to the reasonable pace of the server and shall be ready to receive within a reasonable time of the server being ready.

A receiver who attempts to return the service shall be considered as being ready. If it is demonstrated that the receiver is not ready, the service cannot be called a fault.

### 22. THE LET DURING A SERVICE

The service is a let if:

- a. The ball served touches the net, strap or band, and is otherwise good; or, after touching the net, strap or band, touches the receiver or the receiver's partner or anything they wear or carry before hitting the ground; or
- b. The ball is served when the receiver is not ready.  
In the case of a service let, that particular service shall not count, and the server shall serve again, but a service let does not cancel a previous fault.

Additional approved alternative procedures can be found in Appendix IV.

### 23. THE LET

In all cases when a let is called, except when a service let is called on a second service, the whole point shall be replayed.

**Case 1:** *When the ball is in play, another ball rolls onto court. A let is called. The server had previously served a fault. Is the server now entitled to a first service or second service?*

**Decision:** *First service. The whole point must be replayed.*

### 24. PLAYER LOSES POINT

The point is lost if:

- a. The player serves two consecutive faults; or
- b. The player does not return the ball in play before it bounces twice consecutively; or
- c. The player returns the ball in play so that it hits the ground, or before it bounces, an object, outside the correct court; or
- d. The player returns the ball in play so that, before it bounces, it hits a permanent fixture; or
- e. The receiver returns the service before it bounces; or
- f. The player deliberately carries or catches the ball in play on the racket or deliberately touches it with the racket more than once; or
- g. The player or the racket, whether in the player's hand or not, or anything which the player is wearing or carrying touches the net, net posts/singles sticks, cord or metal cable, strap or band, or the opponent's court at any time while the ball is in play; or
- h. The player hits the ball before it has passed the net; or
- i. The ball in play touches the player or anything that the player is wearing or carrying, except the racket; or

## X. EXHIBITS

- j. The ball in play touches the racket when the player is not holding it; or
- k. The player deliberately and materially changes the shape of the racket when the ball is in play; or
- l. In doubles, both players touch the ball when returning it.

**Case 1:** *After the server has served a first service, the racket falls out of the server's hand and touches the net before the ball has bounced. Is this a service fault, or does the server lose the point?*

**Decision:** *The server loses the point because the racket touches the net while the ball is in play.*

**Case 2:** *After the server has served a first service, the racket falls out of the server's hand and touches the net after the ball has bounced outside the correct service court. Is this a service fault, or does the server lose the point?*

**Decision:** *This is a service fault because when the racket touched the net the ball was no longer in play.*

**Case 3:** *In a doubles match, the receiver's partner touches the net before the ball that has been served touches the ground outside the correct service court. What is the correct decision?*

**Decision:** *The receiving team loses the point because the receiver's partner touched the net while the ball was in play.*

**Case 4:** *Does a player lose the point if an imaginary line in the extension of the net is crossed before or after hitting the ball?*

**Decision:** *The player does not lose the point in either case provided the player does not touch the opponent's court.*

**Case 5:** *Is a player allowed to jump over the net into the opponent's court while the ball is in play?*

**Decision:** *No. The player loses the point.*

**Case 6:** *A player throws the racket at the ball in play. Both the racket and the ball land in the court on the opponent's side of the net and the opponent(s) is unable to reach the ball. Which player wins the point?*

**Decision:** *The player who threw the racket at the ball loses the point.*

**Case 7:** *A ball that has just been served hits the receiver or in doubles the receiver's partner before it touches the ground. Which player wins the point?*

**Decision:** *The server wins the point, unless it is a service let.*

**Case 8:** *A player standing outside the court hits the ball or catches it before it bounces and claims the point because the ball was definitely going out of the correct court.*

**Decision:** *The player loses the point, unless it is a good return, in which case the point continues.*

### 25. A GOOD RETURN

It is a good return if:

- a. The ball touches the net, net posts/singles sticks, cord or metal cable, strap

## X. EXHIBITS

or band, provided that it passes over any of them and hits the ground within the correct court; except as provided in Rule 2 and 24 (d); or

- b. After the ball in play has hit the ground within the correct court and has spun or been blown back over the net, the player reaches over the net and plays the ball into the correct court, provided that the player does not break Rule 24; or
- c. The ball is returned outside the net posts, either above or below the level of the top of the net, even though it touches the net posts, provided that it hits the ground in the correct court; except as provided in Rules 2 and 24 (d); or
- d. The ball passes under the net cord between the singles stick and the adjacent net post without touching either net, net cord or net post and hits the ground in the correct court, or
- e. The player's racket passes over the net after hitting the ball on the player's own side of the net and the ball hits the ground in the correct court; or
- f. The player hits the ball in play, which hits another ball lying in the correct court.

**Case 1:** *A player returns a ball which then hits a singles stick and hits the ground in the correct court. Is this a good return?*

**Decision:** *Yes. However, if the ball is served and hits the singles stick, it is a service fault.*

**Case 2:** *A ball in play hits another ball which is lying in the correct court. What is the correct decision?*

**Decision:** *Play continues. However, if it is not clear that the actual ball in play has been returned, a let should be called.*

### 26. HINDRANCE

If a player is hindered in playing the point by a deliberate act of the opponent(s), the player shall win the point.

However, the point shall be replayed if a player is hindered in playing the point by either an unintentional act of the opponent(s), or something outside the player's own control (not including a permanent fixture).

**Case 1:** *Is an unintentional double hit a hindrance?*

**Decision:** *No. See also Rule 24 (f).*

**Case 2:** *A player claims to have stopped play because the player thought that the opponent(s) was being hindered. Is this a hindrance?*

**Decision:** *No, the player loses the point.*

**Case 3:** *A ball in play hits a bird flying over the court. Is this a hindrance?*

**Decision:** *Yes, the point shall be replayed.*

**Case 4:** *During a point, a ball or other object that was lying on the player's side of the net when the point started hinders the player. Is this a hindrance?*

**Decision:** *No.*

**Case 5:** *In doubles, where are the server's partner and receiver's partner allowed to stand?*

## X. EXHIBITS

**Decision:** *The server's partner and the receiver's partner may take any position on their own side of the net, inside or outside the court. However, if a player is creating a hindrance to the opponent(s), the hindrance rule should be used.*

### 27. CORRECTING ERRORS

As a principle, when an error in respect of the Rules of Tennis is discovered, all points previously played shall stand. Errors so discovered shall be corrected as follows:

- a. During a standard game or a tie-break game, if a player serves from the wrong half of the court, this should be corrected as soon as the error is discovered and the server shall serve from the correct half of the court according to the score. A fault that was served before the error was discovered shall stand.
- b. During a standard game or a tie-break game, if the players are at the wrong ends of the court, the error should be corrected as soon as it is discovered and the server shall serve from the correct end of the court according to the score.
- c. If a player serves out of turn during a standard game, the player who was originally due to serve shall serve as soon as the error is discovered. However, if a game is completed before the error is discovered the order of service shall remain as altered. In this case, any ball change to be made after an agreed number of games should be made one game later than originally scheduled.

A fault that was served by the opponents(s) before the error was discovered shall not stand.

In doubles, if the partners of one team serve out of turn, a fault that was served before the error was discovered shall stand.

- d. If a player serves out of turn during a tie-break game and the error is discovered after an even number of points have been played, the error is corrected immediately. If the error is discovered after an odd number of points have been played, the order of service shall remain as altered. A fault that was served by the opponent(s) before the error was discovered shall not stand.

In doubles, if the partners of one team serve out of turn, a fault that was served before the error was discovered shall stand.

- e. During a standard game or a tie-break game in doubles, if there is an error in the order of receiving, this shall remain as altered until the end of the game in which the error is discovered. For the next game in which they are the receivers in that set, the partners shall then resume the original order of receiving.
- f. If in error a tie-break game is started at 6 games all, when it was previously agreed that the set would be an "Advantage set", the error shall be corrected immediately if only one point has been played. If the error is discovered after the second point is in play, the set will continue as a "Tie-break set".
- g. If in error a standard game is started at 6 games all, when it was previously agreed that the set would be a "Tie-break set", the error shall be corrected immediately if only one point has been played. If the error is discovered after the second point is in play, the set will continue as an "Advantage set" until the score reaches 8 games all (or a higher even number), when a tie-break game shall be played.



## X. EXHIBITS

- h. If in error an “Advantage set” or “Tie-break set” is started, when it was previously agreed that the final set would be a match tie-break, the error shall be corrected immediately if only one point has been played. If the error is discovered after the second point is in play, the set will continue either until a player or team wins three games (and therefore the set) or until the score reaches 2 games all, when a match tie-break shall be played. However, if the error is discovered after the second point of the fifth game has started, the set will continue as a “Tie-break set”. (See Appendix IV)
- i. If the balls are not changed in the correct sequence, the error shall be corrected when the player/team who should have served with new balls is next due to serve a new game. Thereafter the balls shall be changed so that the number of games between ball changes shall be that originally agreed. Balls should not be changed during a game.

### 28. ROLE OF COURT OFFICIALS

For matches where officials are appointed, their roles and responsibilities can be found in Appendix V.

### 29. CONTINUOUS PLAY

As a principle, play should be continuous, from the time the match starts (when the first service of the match is put in play) until the match finishes.

- a. Between points, a maximum of twenty (20) seconds is allowed. When the players change ends at the end of a game, a maximum of ninety (90) seconds are allowed. However, after the first game of each set and during a tie-break game, play shall be continuous and the players shall change ends without a rest.  
At the end of each set there shall be a set break of a maximum of one hundred and twenty (120) seconds.  
The maximum time starts from the moment that one point finishes until the first service is struck for the next point.  
Event organizers may apply for ITF approval to extend the ninety (90) seconds allowed when the players change ends at the end of a game and the one hundred and twenty (120) seconds allowed at a set break.
- b. If, for reasons outside the player’s control, clothing, footwear or necessary equipment (excluding the racket) is broken or needs to be replaced, the player may be allowed reasonable extra time to rectify the problem.
- c. No extra time shall be given to allow a player to recover condition. However, a player suffering from a treatable medical condition may be allowed one medical time-out of three minutes for the treatment of that medical condition. A limited number of toilet/change of attire breaks may also be allowed, if this is announced in advance of the event.
- d. Event organizers may allow a rest period of a maximum of ten (10) minutes if this is announced in advance of the event. This rest period can be taken after the 3rd set in a best of 5 sets match, or after the 2nd set in a best of 3 sets match.
- e. The warm-up time shall be a maximum of five (5) minutes, unless otherwise decided by the event organizers.

## X. EXHIBITS

### 30. COACHING

Coaching is considered to be communication, advice or instruction of any kind, audible or visible, to a player.

In team events where there is a team captain sitting on-court, the team captain may coach the player(s) during a set break and when the players change ends at the end of a game, but not when the players change ends after the first game of each set and not during a tie-break game.

In all other matches, coaching is not allowed.

**Case 1:** *Is a player allowed to be coached, if the coaching is given by signals in a discreet way?*

**Decision:** No.

**Case 2:** *Is a player allowed to receive coaching when play is suspended?*

**Decision:** Yes.

### RULES OF WHEELCHAIR TENNIS

The game of wheelchair tennis follows the ITF Rules of Tennis with the following exceptions.

#### a. The Two Bounce Rule

The wheelchair tennis player is allowed two bounces of the ball. The player must return the ball before it hits the ground a third time. The second bounce can be either in or out of the court boundaries.

#### b. The Wheelchair

The wheelchair is considered part of the body and all applicable rules, which apply to a player’s body, shall apply to the wheelchair.

#### c. The Service

- i. The service shall be delivered in the following manner. Immediately before commencing the service, the server shall be in a stationary position. The server shall then be allowed one push before striking the ball.
- ii. The server shall throughout the delivery of the service not touch with any wheel, any area other than that behind the baseline within the imaginary extension of the centre mark and sideline.
- iii. If conventional methods for the service are physically impossible for a quadriplegic player, then the player or an individual may drop the ball for such a player. However, the same method of serving must be used each time.

#### d. Player Loses Point

A player loses a point if:

- i. The player fails to return the ball before it has touched the ground three times; or
- ii. Subject to rule e) below the player uses any part of his feet or lower extremities as brakes or as stabilizers while delivering service, stroking a ball, turning or stopping against the ground or against any wheel while the ball is in play; or
- iii. The player fails to keep one buttock in contact with his wheelchair seat when contacting the ball.

## X. EXHIBITS

### e. Propelling the Chair with the Foot

- i. If due to lack of capacity a player is unable to propel the wheelchair via the wheel then he may propel the wheelchair using one foot.
- ii. Even if in accordance with rule e) i. above a player is permitted to propel the chair using one foot, no part of the player's foot may be in contact with the ground:
  - a) during the forward motion of the swing, including when the racket strikes the ball;
  - b) from the initiation of the service motion until the racket strikes the ball.
- iii. A player in breach of this rule shall lose the point.

### f. Wheelchair/Able-bodied Tennis

Where a wheelchair tennis player is playing with or against an able-bodied person in singles or doubles, the Rules of Wheelchair Tennis shall apply for the wheelchair player while the Rules of Tennis for able-bodied tennis shall apply for the able-bodied player. In this instance, the wheelchair player is allowed two bounces while the able-bodied player is allowed only one bounce. **Note:** The definition of lower extremities is: -the lower limb, including the buttocks, hip, thigh, leg, ankle and foot.

#### AMENDMENT TO THE RULES OF TENNIS

The official and decisive text to the Rules of Tennis shall be for ever in the English language and no alteration or interpretation of such Rules shall be made except at an Annual General Meeting of the Council, nor unless notice of the resolution embodying such alteration shall have been received by the Federation in accordance with Article 17 of the Constitution of ITF Ltd (Notice of Resolutions) and such resolution or one having the like effect shall be carried by a majority of two-thirds of the votes recorded in respect of the same.

Any alteration so made shall take effect as from the first day of January following unless the Meeting shall by the like majority decide otherwise.

The Board of Directors shall have power, however, to settle all urgent questions of interpretation subject to confirmation at the General Meeting next following.

This Rule shall not be altered at any time without the unanimous consent of a General Meeting of the Council.

## X. EXHIBITS

### APPENDIX I

#### THE BALL

For all measurements in Appendix I, SI units shall take precedence

- a. The ball shall have a uniform outer surface consisting of a fabric cover and shall be white or yellow in color. If there are any seams they shall be stitch-less.
- b. More than one type of ball is specified. The ball shall conform to the requirements shown in the table below

	TYPE 1 (FAST)	TYPE 2 (MEDIUM) <sup>1</sup>	TYPE 3 (SLOW) <sup>2</sup>	HIGH ALTITUDE <sup>3</sup>
MASS (WEIGHT)	56.0-59.4 grams (1.975-2.095 oz)	56.0-59.4 grams (1.975-2.095 oz)	56.0-59.4 grams (1.975-2.095 oz)	56.0-59.4 grams (1.975-2.095 oz)
SIZE	6.54-6.86 cm (2.57-2.70 in)	6.54-6.86 cm (2.57-2.70 in)	7.00-7.30 cm (2.76-2.87 in)	6.54-6.86 cm (2.57-2.70 in)
REBOUND	135-147 cm (53-58 in)	135-147 cm (53-58 in)	135-147 cm (53-58 in)	122-135 cm (48-53 in)
FORWARD DEFORMATION <sup>4</sup>	0.50-0.60 cm (0.197-0.236 in)	0.56-0.74 cm (0.220-0.291 in)	0.56-0.74 cm (0.220-0.291 in)	0.56-0.74 cm (0.220-0.291 in)
RETURN DEFORMATION <sup>4</sup>	0.67-0.91 cm (0.264-0.358 in)	0.80-1.08 cm (0.315-0.425 in)	0.80-1.08 cm (0.315-0.425 in)	0.80-1.08 cm (0.315-0.425 in)

#### Notes:

- <sup>1</sup> This ball may be pressurised or pressureless. The pressureless ball shall have an internal pressure that is no greater than 7 kPa (1 psi) and may be used for high altitude play above 1,219 m (4,000 feet) above sea level and shall have been acclimatised for 60 days or more at the altitude of the specific tournament.
- <sup>2</sup> This ball is also recommended for high altitude play on any court surface type above 1,219 m (4,000 feet) above sea level.
- <sup>3</sup> This ball is pressurised and is an additional ball specified for high altitude play above 1,219 m (4,000 feet) above sea level only.
- <sup>4</sup> The deformation shall be the average of a single reading along each of three perpendicular axes. No two individual readings shall differ by more than 0.08 cm (0.031 inches).
  - c. In addition, the ball shall conform to the requirements for durability as shown in the following table:

	MASS (WEIGHT)	REBOUND	FORWARD DEFORMATION	RETURN DEFORMATION
MAXIMUM CHANGE <sup>1</sup>	0.4 gr (0.014 oz)	4.0 cm (1.6 in)	0.08 cm (0.031 in)	0.10 cm (0.039 in)

#### Notes:

- <sup>1</sup> The largest permissible change in the specified properties resulting from the durability test described in the current edition of *ITF Approved Tennis Balls & Classified Court Surfaces*. The durability test uses laboratory equipment to simulate the effects of nine games of play.
  - d. All tests for rebound, mass, size, deformation and durability shall be made in

## X. EXHIBITS

accordance with the Regulations described in the current edition of ITF Approved Tennis Balls & Classified Court Surfaces.

### CLASSIFICATION OF COURT PACE

The ITF test method used for determining the pace of a court surface is ITF CS 01/02 (ITF Court Pace Rating) as described in the ITF publication entitled "ITF guide to test methods for tennis court surfaces".

Court surfaces which have an ITF Court Pace Rating of 0 to 29 shall be classified as being Category 1 (slow pace). Examples of court surface types which conform to this classification will include most clay courts and other types of unbound mineral surface.

Court surfaces which have an ITF Court Pace Rating of 30 to 34 shall be classified as being Category 2 (medium-slow pace), while court surfaces with an ITF Court Pace Rating of 35 to 39 shall be classified as being Category 3 (medium pace). Examples of court surface types which conform to this classification will include most acrylic coated surfaces plus some carpet surfaces.

Court surfaces with an ITF Court Pace Rating of 40 to 44 shall be classified as being Category 4 (medium-fast pace), while court surfaces which have an ITF Court Pace Rating of 45 or more shall be classified as being Category 5 (fast pace). Examples of court surface types which conform to this classification will include most natural grass, artificial grass and some carpet surfaces.

**Case 1:** Which ball type should be used on which court surface?

**Decision:** 3 different types of balls are approved for play under the Rules of Tennis, however:

- a. Ball Type 1 (fast speed) is intended for play on slow pace court surfaces
- b. Ball Type 2 (medium speed) is intended for play on medium-slow, medium and medium-fast pace court surfaces
- c. Ball Type 3 (slow speed) is intended for play on fast pace court surfaces

## X. EXHIBITS

### APPENDIX II

#### THE RACKET

For all measurements in Appendix II, SI units shall take precedence

- a. The hitting surface, defined as the main area of the stringing pattern bordered by the points of entry of the strings into the frame or points of contact of the strings with the frame, whichever is the smaller, shall be flat and consist of a pattern of crossed strings connected to a frame and alternately interlaced or bonded where they cross. The stringing pattern must be generally uniform and, in particular, not less dense in the centre than in any other area. The racket shall be designed and strung such that the playing characteristics are identical on both faces. The racket shall be free of attached objects, protrusions and devices other than those utilized solely and specifically to limit or prevent wear and tear or vibration or, for the frame only, to distribute weight. These objects, protrusions and devices must be reasonable in size and placement for such purposes.
- b. The frame of the racket shall not exceed 73.7 cm (29.0 inches) in overall length, including the handle. The frame of the racket shall not exceed 31.7 cm (12.5 inches) in overall width. The hitting surface shall not exceed 39.4 cm (15.5 inches) in overall length, and 29.2 cm (11.5 inches) in overall width.
- c. The frame, including the handle, and the strings, shall be free of any device which makes it possible to change materially the shape of the racket, or to change materially the weight distribution in the direction of the longitudinal axis of the racket which would alter the swing moment of inertia, or to change deliberately any physical property which may affect the performance of the racket during the playing of a point. No energy source that in any way changes or affects the playing characteristics of a racket may be built into or attached to a racket.
- d. The racket must be free of any device that may provide communication, advice or instruction of any kind, audible or visible, to a player during a match.

## X. EXHIBITS

### APPENDIX III

#### ADVERTISING

1. Advertising is permitted on the net as long as it is placed on the part of the net that is within 3 feet (0.914 m) from the centre of the net posts and is produced in such a way that it does not interfere with the vision of the players or the playing conditions.
2. Advertising and other marks or material placed at the back and sides of the court shall be permitted unless it interferes with the vision of the players or the playing conditions.
3. Advertising and other marks or material placed on the court surface outside the lines is permitted unless it interferes with the vision of the players or the playing conditions.
4. Notwithstanding paragraphs (1), (2) and (3) above, any advertising, marks or material placed on the net or placed at the back and sides of the court, or on the court surface outside the lines may not contain white or yellow or other light colors that may interfere with the vision of the players or the playing conditions.
5. Advertising and other marks or material are not permitted on the court surface inside the lines of the court.

## X. EXHIBITS

### APPENDIX IV

#### ALTERNATIVE PROCEDURES AND SCORING METHODS

##### SCORE IN A GAME (Rule 5):

###### “No-Ad” SCORING METHOD

This alternative scoring method may be used.

A “No-Ad” game is scored as follows with the server’s score being called first:

No point	-	“Love”
First point	-	“15”
Second point	-	“30”
Third point	-	“40”
Fourth point	-	“Game”

If both players/teams have won three points each, the score is “Deuce” and a deciding point shall be played. The receiver(s) shall choose whether to receive the service from the right half or the left half of the court. In doubles, the players of the receiving team cannot change positions to receive this deciding point. The player/team who wins the deciding point wins the “Game”.

In mixed doubles, the player of the same gender as the server shall receive the deciding point. The players of the receiving team cannot change positions to receive the deciding point.

##### SCORE IN A SET (Rules 6 and 7):

###### 1. “SHORT” SETS

The first player/team who wins four games wins that set, provided there is a margin of two games over the opponent(s). If the score reaches four games all, a tie-break game shall be played.

###### 2. MATCH TIE-BREAK (7 POINTS)

When the score in a match is one set all, or two sets all in best of five sets matches, one tie-break game shall be played to decide the match. This tie-break game replaces the deciding final set.

The player/team who first wins seven points shall win this match tie-break and the match provided there is a margin of two points over the opponent(s).

###### 3. MATCH TIE-BREAK (10 POINTS)

When the score in a match is one set all, or two sets all in best of five sets matches, one tie-break game shall be played to decide the match. This tie-break game replaces the deciding final set.

## X. EXHIBITS

The player/team who first wins ten points shall win this match tie-break and the match provided there is a margin of two points over the opponent(s).

**Note:** When using the match tie-break to replace the final set:

- the original order of service continues. (Rules 5 and 14)
- in doubles, the order of serving and receiving within the team may be altered, as in the beginning of each set. (Rules 14 and 15)
- before the start of the match tie-break there shall be a 120 seconds set break.
- balls should not be changed before the start of the match tie-break even if a ball change is due.

### CHANGE OF ENDS (Rule 10):

This alternative to the change of ends sequence in a tie-break game may be used.

During a tie-break game, players shall change ends after the first point and thereafter after every four points.

### THE LET DURING A SERVICE (Rule 22):

This alternative is play without the service let in Rule 22 a.

It means that a serve that touches the net, strap or band, is in play.

(This alternative is commonly known as the “no let rule”)

## X. EXHIBITS

### APPENDIX V

#### ROLE OF COURT OFFICIALS

The referee is the final authority on all questions of tennis law and the referee's decision is final.

In matches where a chair umpire is assigned, the chair umpire is the final authority on all questions of fact during the match.

The players have the right to call the referee to court if they disagree with a chair umpire's interpretation of tennis law.

In matches where line umpires and net umpires are assigned, they make all calls (including foot-fault calls) relating to that line or net. The chair umpire has the right to overrule a line umpire or a net umpire if the chair umpire is sure that a clear mistake has been made. The chair umpire is responsible for calling any line (including foot-faults) or net where no line umpire or net umpire is assigned.

A line umpire who cannot make a call shall signal this immediately to the chair umpire who shall make a decision. If the line umpire can not make a call, or if there is no line umpire, and the chair umpire can not make a decision on a question of fact, the point shall be replayed.

In team events where the referee is sitting on-court, the referee is also the final authority on questions of fact.

Play may be stopped or suspended at any time the chair umpire decides it is necessary or appropriate.

The referee may also stop or suspend play in the case of darkness, weather or adverse court conditions. When play is suspended for darkness, this should be done at the end of a set, or after an even number of games have been played in the set in progress. After a suspension in play, the score and position of players on-court in the match shall stand when the match resumes.

The chair umpire or referee shall make decisions regarding continuous play and coaching in respect of any Code of Conduct that is approved and in operation.

**Case 1:** *The chair umpire awards the server a first service after an overrule, but the receiver argues that it should be a second service, since the server had already served a fault. Should the referee be called to court to give a decision?*

**Decision:** *Yes. The chair umpire makes the first decision about questions of tennis law (issues relating to the application of specific facts). However, if a player appeals the chair umpire's decision, then the referee shall be called to make the final decision.*

**Case 2:** *A ball is called out, but a player claims that the ball was good. May the referee be called to court to make a decision?*

**Decision:** *No. The chair umpire makes the final decision on ques-*

## X. EXHIBITS

tions of fact (issues relating to what actually happened during a specific incident).

**Case 3:** Is a chair umpire allowed to overrule a line umpire at the end of a point if, in the chair umpire's opinion, a clear mistake was made earlier in the point?

**Decision:** No. A chair umpire may only overrule a line umpire immediately after the clear mistake has been made.

**Case 4:** A line umpire calls a ball "Out" and then the player argues that the ball was good. Is the chair umpire allowed to overrule the line umpire?

**Decision:** No. A chair umpire must never overrule as the result of the protest or appeal by a player

**Case 5:** A line umpire calls a ball "Out". The chair umpire was unable to see clearly, but thought the ball was in. May the chair umpire overrule the line umpire?

**Decision:** No. The chair umpire may only overrule when sure that the line umpire made a clear mistake.

**Case 6:** Is a line umpire allowed to change the call after the chair umpire has announced the score?

**Decision:** Yes. If a line umpire realizes a mistake, a correction should be made as soon as possible provided it is not as the result of a protest or appeal of a player.

**Case 7:** If a chair umpire or line umpire calls "out" and then corrects the call to good, what is the correct decision?

**Decision:** The chair umpire must decide if the original "out" call was a hindrance to either player. If it was a hindrance, the point shall be replayed. If it was not a hindrance, the player who hit the ball wins the point.

**Case 8:** A ball is blown back over the net and the player correctly reaches over the net to try to play the ball. The opponent(s) hinders the player from doing this. What is the correct decision?

**Decision:** The chair umpire must decide if the hindrance was deliberate or unintentional and either awards the point to the hindered player or order the point to be replayed.

### BALL MARK INSPECTION PROCEDURES

1. Ball mark inspections can only be made on clay courts.
2. A ball mark inspection requested by a player (team) shall be allowed only if the chair umpire cannot determine the call with certainty from his/her chair on either a point-ending shot or when a player (team) stops playing the point during a rally (returns are permitted but then the player must immediately stop).
3. When the chair umpire has decided to make a ball mark inspection, he/she should go down from the chair and make the inspection himself. If he/she does not know where the mark is, he/she can ask the line umpire for help in locating the mark, but then the chair umpire shall inspect it.
4. The original call or overrule will always stand if the line umpire and chair umpire

## X. EXHIBITS

cannot determine the location of the mark or if the mark is unreadable.

5. Once the chair umpire has identified and ruled on a ball mark, this decision is final and not appealable.
6. In clay court tennis the chair umpire should not be too quick to announce the score unless absolutely certain of the call. If in doubt, wait before calling the score to determine whether a ball mark inspection is necessary.
7. In doubles the appealing player must make his/her appeal in such a way that either play stops or the chair umpire stops play. If an appeal is made to the chair umpire then he/she must first determine that the correct appeal procedure was followed. If it was not correct or if it was late, then the chair umpire may determine that the opposing team was deliberately hindered.
8. If a player erases the ball mark before the chair umpire has made a final decision, he/she concedes the call.
9. A player may not cross the net to check a ball mark without being subject to the Unsportsmanlike provision of the Code of Conduct.

### ELECTRONIC REVIEW PROCEDURES

At tournaments where an Electronic Review System is used, the following procedures should be followed for matches on courts where it is used.

1. A request for an Electronic Review of a line call or overrule by a player (team) shall be allowed only on either a point-ending shot or when a player (team) stops playing the point during a rally (returns are permitted but then the player must immediately stop).
2. The chair umpire should decide to use the Electronic Review when there is doubt about the accuracy of the line call or overrule. However, the chair umpire may refuse the Electronic Review if he/she believes that the player is making an unreasonable request or that it was not made in a timely manner.
3. In doubles the appealing player must make his/her appeal in such a way that either play stops or the chair umpire stops play. If an appeal is made to the chair umpire then he/she must first determine that the correct appeal procedure was followed. If it was not correct or if it was late, then the chair umpire may determine that the opposing team was deliberately hindered, in which case the appealing team loses the point.
4. The original call or overrule will always stand if the Electronic Review is unable, for whatever reason, to make a decision on that line call or overrule.
5. The chair umpire's final decision will be the outcome of the Electronic Review and is not appealable. If a manual choice is required for the system to review a particular ball impact, a review official approved by the referee shall decide which ball impact is reviewed.
6. Each player (team) is allowed three (3) unsuccessful appeals per set, plus one (1) additional appeal in the tie-break. For matches with advantage sets, players (teams) will start again with a maximum of three (3) unsuccessful appeals at 6 games all and every 12 games thereafter. For matches with match tie-break, the match tie-break counts as a new set and each player (team) starts with three (3) appeals. Players (teams) will have an unlimited number of successful appeals.

## X. EXHIBITS

### APPENDIX VI

#### OFFICIAL 10 AND UNDER TENNIS COMPETITION

##### Courts:

In addition to the (full sized) court described in Rule 1, the following court dimensions may be used for 10 and under tennis competition:

- A court, designated “red” for the purposes of 10 and under tennis competition, shall be a rectangle, between 36 feet (10.97 m) and 42 feet (12.80 m) long, and between 14 feet (4.27 m) and 20 feet (6.10 m) wide. The net shall be between 31.5 inches (0.800 m) and 33.0 inches (0.838m) high at the centre.
- A court, designated “orange”, shall be a rectangle, between 58 feet (17.68 m) and 60 feet (18.29 m) long, and between 20 feet (6.10 m) and 27 feet (8.23 m) wide. The net shall be between 31.5 inches (0.800 m) and 36.0 inches (0.914m) high at the centre.

##### Balls:

From January 2012, only the following ball types can be used in 10 and under tennis competition:

- A stage 3 (red) ball, which is recommended for play on a “red” court, by players aged up to 8 years, using a racket up to 23 inches (58.4 cm) long.
- A stage 2 (orange) ball, which is recommended for play on an “orange” court, by players aged 8 to 10 years, using a racket between 23 inches (58.4 cm) and 25 inches (63.5) cm long.
- A stage 1 (green) ball, which is recommended for play on a full sized court, by advanced players aged 9 to 10 years, using a racket between 25 inches (63.5 cm) and 26 inches (66.0 cm) long.

**Note:** From January 2012, other ball types described in Appendix I cannot be used in 10 and under tennis competition.

##### Specifications for stage 1, 2 and 3 balls:

	STAGE 3 (RED) FOAM	STAGE 3 (RED) FOAM	STAGE 2 (ORANGE) STANDARD	STAGE 1 (GREEN) STANDARD
MASS (WEIGHT)	25.0-43.0 gr (0.882-1.517 oz)	36.0-49.0 gr (1.270-1.728 oz)	36.0-46.9 gr (1.270-1.654 oz)	47.0-51.5 gr (1.658-1.817 oz)
SIZE	8.00-9.00 cm (3.15-3.54 in)	7.00-8.00 cm (2.76-3.15 in)	6.00-6.86 cm (2.36-2.70 in)	6.30-6.86 cm (2.48-2.70 in)
REBOUND	85-105 cm (33-41 in)	90-105 cm (35-41 in)	105-120 cm (41-47 in)	120-135 cm (47-53 in)
FORWARD DEFORMATION <sup>4</sup>	-----	-----	1.40-1.65 cm (0.551-0.650 in)	0.80-1.05 cm (0.315-0.413 in)

All tests for rebound, mass, size and deformation shall be made in accordance with the regulations described in the current edition of ITF Approved Tennis Balls & Classified Court Surfaces.

## X. EXHIBITS

### Scoring methods:

For 10 and under tennis competition using stage 3 (red), stage 2 (orange) or stage 1 (green) balls, scoring methods specified in the Rules of Tennis (including the Appendix IV) can be utilized, in addition to short duration scoring methods involving matches of one match tie-break, best of 3 tie-breaks/match tie-breaks or one set.





## X. EXHIBITS

The centreline and service line are now marked by means of the points F, H, G, which are measured 21'0" (6.40 m) from the net down the lines bc, XJ, ad, respectively.

Identical procedure the other side of the net completes the court.

If a singles court only is required, no lines are necessary outside the points a, b, c, d, but the court can be measured out as above. Alternatively, the corners of the baseline (c, d) can be found if preferred by pegging the two tapes at a and b instead of at A and B, and by then using lengths of 47'5" (14.46 m) and 39'0" (11.89 m). The net posts will be at n, n, and a 33'0" (10 m) singles net should be used.

When a combined doubles and singles court with a doubles net is used for singles, the net must be supported at the points n, n, to a height of 3 feet 6 inches (1.07 m) by means of two singles sticks, which shall be not more than 3 inches (7.5 cm) square or 3 inches (7.5 cm) in diameter. The centers of the singles sticks shall be 3 feet (.914 m) outside the singles court on each side.

To assist in the placing of these singles sticks it is desirable that the points n, n, should each be shown with a white dot when the court is marked.

### Note:

As a guide for international competitions, the recommended minimum distance between the baselines and the backstops should be 21 feet (6.40 m) and between the sidelines and the sidestops the recommended minimum distance should be 12 feet (3.66 m).

As a guide for recreational and Club play, the recommended minimum distance between the baselines and the backstops should be 18 feet (5.48 m) and between the sidelines and the sidestops the recommended minimum distance should be 10 feet (3.05 m).

As a guide, the recommended minimum height to the ceiling should be 30 feet (9.14 m).

## X. EXHIBITS

### APPENDIX VII

#### PROCEDURES FOR REVIEW AND HEARINGS ON THE RULES OF TENNIS

##### 1. INTRODUCTION

- 1.1 These procedures were approved by the Board of Directors of the International Tennis Federation ("Board of Directors") on 17 May 1998.
- 1.2 The Board of Directors may from time to time supplement, amend, or vary these procedures.

##### 2. OBJECTIVES

- 2.1 The International Tennis Federation is the custodian of the Rules of Tennis and is committed to:
  - a. Preserving the traditional character and integrity of the game of tennis.
  - b. Actively preserving the skills traditionally required to play the game.
  - c. Encouraging improvements, which maintain the challenge of the game.
  - d. Ensuring fair competition.
- 2.2 To ensure fair, consistent and expeditious review and hearings in relation to the Rules of Tennis the procedures set out below shall apply.

##### 3. SCOPE

- 3.1 These Procedures shall apply to Rulings under:
  - a. Rule 1 – The Court.
  - b. Rule 3 – The Ball.
  - c. Rule 4 – The Racket.
  - d. Appendix I and II of the Rules of Tennis.
  - e. Any other Rules of Tennis which the International Tennis Federation may decide.

##### 4. STRUCTURE

- 4.1 Under these procedures Rulings shall be issued by a Ruling Board.
- 4.2 Such Rulings shall be final save, for an entitlement to appeal to an Appeal Tribunal pursuant to these procedures.

##### 5. APPLICATION

- 5.1 Rulings shall be taken either:
  - a. Following a motion of the Board of Directors; or
  - b. Upon the receipt of an application in accordance with the procedures set out below.

##### 6. APPOINTMENT AND COMPOSITION OF RULING BOARDS

- 6.1 Ruling Boards shall be appointed by the President of the International Tennis Federation ("President") or his designee and shall comprise of such a number, as the President or his designee shall determine.

## X. EXHIBITS

- 6.2 If more than one person is appointed to the Ruling Board the Ruling Board shall nominate one person from amongst themselves to act as Chairperson.
- 6.3 The Chairperson shall be entitled to regulate the procedures prior to and at any review and/or hearing of a Ruling Board.

### 7. PROPOSED RULINGS BY THE RULING BOARD

- 7.1 The details of any proposed Ruling issued upon the motion of the Board of Directors may be provided to any bona fide person or any players, equipment manufacturer or national association or members thereof with an interest in the proposed Ruling.
- 7.2 Any person so notified shall be given a reasonable period within which to forward comments, objections, or requests for information to the President or his designee in connection with the proposed Ruling.

### 8. APPLICATION FOR RULINGS

- 8.1 An application for a Ruling may be made by any party with a bona fide interest in the Ruling including any player, equipment manufacturer or national association or member thereof.
- 8.2 Any application for a Ruling must be submitted in writing to the President.
- 8.3 To be valid an application for a Ruling must include the following minimum information:
- The full name and address of the Applicant.
  - The date of the application.
  - A statement clearly identifying the interest of the Applicant in the question upon which a Ruling is requested.
  - All relevant documentary evidence upon which the Applicant intends to rely at any hearing.
  - If, in the opinion of the Applicant, expert evidence is necessary he shall include a request for such expert evidence to be heard. Such request must identify the name of any expert proposed and their relevant expertise.
  - When an application for a Ruling on a racket or other piece of equipment is made, a prototype or, exact, copy of the equipment in question must be submitted with the application for a Ruling.
  - If, in the opinion of the Applicant, there are extraordinary or unusual circumstances, which require a Ruling to be made within a specified time or before a specified date he shall include a statement describing the extraordinary or unusual circumstances.
- 8.4 If an application for a Ruling does not contain the information and/or equipment referred to at Clause 8. 3 (a)-(g) above the President or his designee shall notify the Applicant giving the Applicant a specified reasonable time within which to remedy the defect. If the Applicant fails to remedy the defect within the specified time the application shall be dismissed.

### 9. CONVENING THE RULING BOARD

- 9.1 On receipt of a valid application or on the motion of the Board of Directors the President or his designee may convene a Ruling Board to deal with the application or motion.

## X. EXHIBITS

- 9.2 The Ruling Board need not hold a hearing to deal with an application or motion where the application or motion, in the opinion of the Chairperson can be resolved in a fair manner without a hearing.

### 10. PROCEDURE OF THE RULING BOARD

- 10.1 The Chairperson of a Ruling Board shall determine the appropriate form, procedure and date of any review and/or hearing.
- 10.2 The Chairperson shall provide written notice of those matters set out at 10.1 above to any Applicant or any person or association who has expressed an interest in the proposed Ruling.
- 10.3 The Chairperson shall determine all matters relating to evidence and shall not be bound by judicial rules governing procedure and admissibility of evidence provided that the review and/or hearing is conducted in a fair manner with a reasonable opportunity for the relevant parties to present their case.
- 10.4 Under these procedures any review and/or hearings:
- Shall take place in private.
  - May be adjourned and/or postponed by the Ruling Board.
- 10.5 The Chairperson shall have the discretion to co-opt from time to time additional members onto the Ruling Board with special skill or experience to deal with specific issues, which require such special skill or experience.
- 10.6 The Ruling Board shall take its decision by a simple majority. No member of the Ruling Board may abstain.
- 10.7 The Chairperson shall have the complete discretion to make such order against the Applicant [and/or other individuals or organizations commenting objecting or requesting information at any review and/or hearing] in relation to the costs of the application and/or the reasonable expenses incurred by the Ruling Board in holding tests or obtaining reports relating to equipment subject to a Ruling as he shall deem appropriate.

### 11. NOTIFICATION

- 11.1 Once a Ruling Board has reached a decision it shall provide written notice to the Applicant, or, any person or association who has expressed an interest in the proposed Ruling as soon as reasonably practicable.
- 11.2 Such written notice shall include a summary of the reasoning behind the decision of the Ruling Board.
- 11.3 Upon notification to the Applicant or upon such other date specified by the Ruling Board the Ruling of the Ruling Board shall be immediately binding under the Rules of Tennis.

### 12. APPLICATION OF CURRENT RULES OF TENNIS

- 12.1 Subject to the power of the Ruling Board to issue interim Rulings the current Rules of Tennis shall continue to apply until any review and/or hearing of the Ruling Board is concluded and a Ruling issued by the Ruling Board.
- 12.2 Prior to and during any review and/or hearing the Chairperson of the Ruling Board may issue such directions as are deemed reasonably necessary in the implemen-

## X. EXHIBITS

tation of the Rules of Tennis and of these procedures including the issue of interim Rulings.

- 12.3** Such interim Rulings may include restraining orders on the use of any equipment under the Rules of Tennis pending a Ruling by the Ruling Board as to whether or not the equipment meets the specification of the Rules of Tennis.

### 13. APPOINTMENT AND COMPOSITION OF APPEAL TRIBUNALS

- 13.1** Appeal Tribunals shall be appointed by the President or his designee from [members of the Board of Directors/Technical Commission].
- 13.2** No member of the Ruling Board who made the original Ruling shall be a member of the Appeal Tribunal.
- 13.3** The Appeal Tribunal shall comprise of such number as the President or his designee shall determine but shall be no less than three.
- 13.4** The Appeal Tribunal shall nominate one person from amongst themselves to act as Chairperson.
- 13.5** The Chairperson shall be entitled to regulate the procedures prior to and at any appeal hearing.

### 14. APPLICATION TO APPEAL

- 14.1** An Applicant [or a person or association who has expressed an interest and forwarded any comments, objections, or requests to a proposed Ruling] may appeal any Ruling of the Ruling Board.
- 14.2** To be valid an application for an appeal must be:
- a. Made in writing to the Chairperson of the Ruling Board who made the Ruling appealed not later than [45] days following notification of the Ruling;
  - b. Must set out details of the Ruling appealed against; and
  - c. Must contain the full grounds of the appeal.
- 14.3** Upon receipt of a valid application to appeal the Chairperson of the Ruling Board making the original Ruling may require a reasonable appeal fee to be paid by the Appellant as a condition of appeal. Such appeal fee shall be repaid to the Appellant if the appeal is successful.

### 15. CONVENING THE APPEAL TRIBUNAL

- 15.1** The President or his designee shall convene the Appeal Tribunal following payment by the Appellant of any appeal fee.

### 16. PROCEDURES OF APPEAL TRIBUNAL

- 16.1** The Appeal Tribunal and their Chairperson shall conduct procedures and hearings in accordance with those matters set out in sections 10, 11 and 12 above.
- 16.2** Upon notification to the Appellant or upon such other date specified by the Appeal Tribunal the Ruling of the Appeal Tribunal shall be immediately binding and final under the Rules of Tennis.

### 17. GENERAL

## X. EXHIBITS

- 17.1** If a Ruling Board consists of only one member that single member shall be responsible for regulating the hearing as Chairperson and shall determine the procedures to be followed prior to and during any review and/or hearing.
- 17.2** All review and/or hearings shall be conducted in English. In any hearing where an Applicant, and/or other individuals or organizations commenting, objecting or requesting information do not speak English an interpreter must be present. Wherever practicable the interpreter shall be independent.
- 17.3** The Ruling Board or Appeal Tribunal may publish extracts from its own Rulings.
- 17.4** All notifications to be made pursuant to these procedures shall be in writing.
- 17.5** Any notifications made pursuant to these procedures shall be deemed notified upon the date that they were communicated, sent or transmitted to the Applicant or other relevant party.
- 17.6** A Ruling Board shall have the discretion to dismiss an application if in its reasonable opinion the application is substantially similar to an application or motion upon which a Ruling Board has made a decision and/or Ruling within the 36 months prior to the date of the application.

# X. EXHIBITS

## EXHIBIT J - Prize Money

PRIZE MONEY DISTRIBUTION		2012 ATP World Tour 250 - USD				
<b>CONTRIBUTIONS:</b>						
ON - SITE	398,250	410,850	434,250	434,250	442,500	
RETIREMENT	9,955	10,270	10,850	10,865	11,080	
PLAYER PROMOTION	4,895	5,055	5,340	5,340	5,440	
<b>PLAYERS MONEY</b>	<b>383,400</b>	<b>395,525</b>	<b>418,060</b>	<b>418,045</b>	<b>425,980</b>	
<b>SINGLES DRAW SIZE</b>	<b>28 Draw</b>	<b>32 Draw</b>	<b>28 Draw</b>	<b>32 Draw</b>	<b>28 Draw</b>	
<b>SINGLES TOTAL</b>	<b>306,720</b>	<b>316,425</b>	<b>334,460</b>	<b>334,445</b>	<b>340,730</b>	
W	71,900	70,365	78,360	74,370	79,880	
F	37,860	37,060	41,290	39,165	42,070	
S	20,510	20,070	22,365	21,215	22,790	
Q	11,685	11,445	12,740	12,090	12,980	
16	6,885	6,740	7,510	7,120	7,650	
32	4,080	3,990	4,450	4,220	4,530	
56						
96						
	32 Draw	32 Draw	32 Draw	32 Draw	32 Draw	
Q3	660	680	720	720	730	
Q2	315	325	345	345	350	
<b>DOUBLES DRAW SIZE</b>	<b>16 Draw</b>	<b>16 Draw</b>	<b>16 Draw</b>	<b>16 Draw</b>	<b>16 Draw</b>	
<b>DOUBLES TOTAL</b>	<b>76,680</b>	<b>79,100</b>	<b>83,600</b>	<b>83,600</b>	<b>85,250</b>	
W	21,800	22,530	23,800	23,800	24,270	
F	11,480	11,850	12,520	12,520	12,760	
S	6,220	6,420	6,780	6,780	6,910	
Q	3,560	3,670	3,890	3,890	3,960	
16	2,090	2,150	2,270	2,270	2,320	
24/32						

Auckland
St. Petersburg
Sydney
Brisbane
Houston

Chennai

Newport

Vina del Mar



# X. EXHIBITS

PRIZE MONEY DISTRIBUTION		2012 ATP World Tour 250 - USD				
<b>CONTRIBUTIONS:</b>						
ON - SITE	442,500	475,300	477,900	484,100	531,000	
RETIREMENT	11,060	11,855	11,950	12,110	13,275	
PLAYER PROMOTION	5,430	5,845	5,875	5,955	6,510	
<b>PLAYERS MONEY</b>	<b>426,010</b>	<b>457,600</b>	<b>460,075</b>	<b>466,035</b>	<b>511,215</b>	
<b>SINGLES DRAW SIZE</b>	<b>32 Draw</b>	<b>28 Draw</b>	<b>28 Draw</b>	<b>32 Draw</b>	<b>28 Draw</b>	
<b>SINGLES TOTAL</b>	<b>340,760</b>	<b>366,050</b>	<b>368,065</b>	<b>372,845</b>	<b>408,945</b>	
W	75,780	85,800	86,270	82,900	95,860	
F	39,900	45,190	45,435	43,665	50,485	
S	21,620	24,480	24,610	23,650	27,350	
Q	12,320	13,940	14,020	13,475	15,580	
16	7,255	8,220	8,265	7,945	9,180	
32	4,300	4,870	4,895	4,705	5,440	
56						
96						
	32 Draw	32 Draw	32 Draw	32 Draw	32 Draw	
Q3	730	785	790	800	875	
Q2	350	375	380	380	420	
<b>DOUBLES DRAW SIZE</b>	<b>16 Draw</b>	<b>16 Draw</b>	<b>16 Draw</b>	<b>16 Draw</b>	<b>16 Draw</b>	
<b>DOUBLES TOTAL</b>	<b>85,250</b>	<b>91,550</b>	<b>92,010</b>	<b>93,190</b>	<b>102,270</b>	
W	24,270	26,070	26,210	26,550	29,120	
F	12,760	13,700	13,780	13,960	15,310	
S	6,910	7,430	7,470	7,560	8,300	
Q	3,960	4,250	4,270	4,330	4,750	
16	2,320	2,490	2,500	2,530	2,780	
24/32						

Delray Beach
Sao Paulo
Atlanta
Buenos Aires
San Jose



# X. EXHIBITS

## PRIZE MONEY DISTRIBUTION 2012 ATP World Tour 250 - USD

### CONTRIBUTIONS:

ON - SITE	551,000	553,125	557,550	673,150	850,000	1,024,000
RETIREMENT	13,780	13,830	13,940	16,830	21,250	25,600
PLAYER PROMOTION	6,775	6,785	6,860	8,280	10,435	12,600
PLAYERS MONEY	530,445	532,510	536,750	648,040	818,315	985,800
SINGLES DRAW SIZE	28 Draw	48 Draw	28 Draw	28 Draw	28 Draw	32 Draw
SINGLES TOTAL	424,355	425,990	429,400	518,400	654,635	788,600
W	99,465	73,930	100,650	121,520	153,440	175,380
F	52,390	42,090	53,000	64,000	80,815	92,360
S	28,380	24,295	28,715	34,670	43,780	50,030
Q	16,170	14,300	16,360	19,750	24,940	28,500
16	9,525	8,335	9,640	11,640	14,700	16,795
32	5,645	5,065	5,710	6,895	8,705	9,950
56		3,080				
96						
	32 Draw	32 Draw	32 Draw	32 Draw	32 Draw	32 Draw
Q3	910	915	920	1,110	1,400	1,690
Q2	435	440	445	530	675	810
DOUBLES DRAW SIZE	16 draw	16 draw	16 Draw	16 Draw	16 Draw	16 Draw
DOUBLES TOTAL	106,090	106,520	107,350	129,640	163,680	197,200
W	30,220	30,330	30,580	36,950	46,620	56,160
F	15,890	15,950	16,070	19,410	24,500	29,520
S	8,610	8,640	8,710	10,520	13,280	16,000
Q	4,930	4,940	4,980	6,020	7,600	9,160
16	2,880	2,900	2,920	3,520	4,450	5,360
24/32						



Doha  
Kuala Lumpur  
Moscow  
Los Angeles  
Winston-Salem  
Bangkok

# X. EXHIBITS

## PRIZE MONEY DISTRIBUTION 2012 ATP World Tour 250 - EUR

### CONTRIBUTIONS:

ON - SITE	358,425	366,950	398,250	398,250
RETIREMENT	8,955	9,175	9,955	9,955
PLAYER PROMOTION	4,400	4,515	4,895	4,895
PLAYERS MONEY	345,070	353,260	383,400	383,400
SINGLES DRAW SIZE	28 Draw	28 Draw	32 Draw	28 Draw
SINGLES TOTAL	276,040	282,620	306,720	306,720
W	64,700	66,250	68,220	71,900
F	34,080	34,890	35,920	37,860
S	18,460	18,900	19,460	20,510
Q	10,515	10,765	11,085	11,685
16	6,200	6,345	6,530	6,885
32	3,670	3,760	3,870	4,080
56				
96				
	32 Draw	32 Draw	32 Draw	32 Draw
Q3	590	605	660	660
Q2	285	290	315	315
DOUBLES DRAW SIZE	16 Draw	16 Draw	16 Draw	16 Draw
DOUBLES TOTAL	69,030	70,640	76,680	76,680
W	19,660	20,120	21,800	21,800
F	10,330	10,580	11,480	11,480
S	5,600	5,730	6,220	6,220
Q	3,200	3,280	3,560	3,560
16	1,880	1,920	2,090	2,090
24/32				



Bucharest  
Casablanca  
Estoril  
Metz  
Montpellier  
Munich  
Nice  
Zagreb  
s-Hertogenbosch  
Belgrade  
Bastad  
Gstaad  
Kitzbuhel  
Stuttgart  
Umag

# X. EXHIBITS

## PRIZE MONEY DISTRIBUTION 2012 ATP World Tour 250 - EUR

**CONTRIBUTIONS:**

ON - SITE	403,950	486,750	512,750	625,300	663,750
RETIREMENT	10,100	12,170	12,800	15,630	16,595
PLAYER PROMOTION	4,970	5,980	6,300	7,690	8,160
<b>PLAYERS MONEY</b>	<b>388,880</b>	<b>468,600</b>	<b>493,650</b>	<b>601,980</b>	<b>638,995</b>
<b>SINGLES DRAW SIZE</b>	<b>28 Draw</b>	<b>28 Draw</b>	<b>28 Draw</b>	<b>56 Draw</b>	<b>28 Draw</b>
<b>SINGLES TOTAL</b>	<b>311,140</b>	<b>374,850</b>	<b>394,890</b>	<b>481,620</b>	<b>511,155</b>
W	72,950	87,870	92,560	78,935	119,800
F	38,400	46,280	48,750	44,945	63,105
S	20,805	25,070	26,410	25,940	34,185
Q	11,850	14,280	15,045	15,625	19,475
16	6,985	8,415	8,865	8,900	11,475
32	4,140	4,985	5,250	5,410	6,800
56				3,290	
96					
	32 Draw	32 Draw	32 Draw	32 Draw	32 Draw
Q3	665	805	845	1,030	1,095
Q2	320	385	410	495	525
<b>DOUBLES DRAW SIZE</b>	<b>16 Draw</b>	<b>16 Draw</b>	<b>16 Draw</b>	<b>24 Draw</b>	<b>16 Draw</b>
<b>DOUBLES TOTAL</b>	<b>77,740</b>	<b>93,750</b>	<b>98,760</b>	<b>120,360</b>	<b>127,840</b>
W	22,150	26,700	28,120	29,200	36,400
F	11,650	14,030	14,780	15,540	19,140
S	6,310	7,610	8,010	8,470	10,370
Q	3,610	4,350	4,580	4,990	5,930
16	2,110	2,550	2,690	3,010	3,480
24/32				1,830	

Halle  
London  
Marseille  
Stockholm  
Vienna  
Eastbourne



# X. EXHIBITS

## PRIZE MONEY DISTRIBUTION 2102 ATP World Tour 500 - USD

**CONTRIBUTIONS:**

ON - SITE	1,049,760	1,155,000	1,280,565	1,700,475	2,205,000
RETIREMENT	26,245	28,875	32,015	42,510	55,130
PLAYER PROMOTION	12,905	14,210	15,750	20,915	27,120
<b>PLAYERS MONEY</b>	<b>1,010,610</b>	<b>1,111,915</b>	<b>1,232,800</b>	<b>1,637,050</b>	<b>2,122,750</b>
<b>SINGLES DRAW SIZE</b>	<b>32 Draw</b>	<b>32 Draw</b>	<b>32 Draw</b>	<b>32 Draw</b>	<b>32 Draw</b>
<b>SINGLES TOTAL</b>	<b>808,360</b>	<b>889,375</b>	<b>986,090</b>	<b>1,309,460</b>	<b>1,697,950</b>
W	252,600	277,915	308,130	409,170	530,570
F	113,880	125,300	138,920	184,470	239,200
S	53,940	59,350	65,800	87,380	113,310
Q	26,030	28,640	31,750	42,165	54,675
16	13,270	14,600	16,190	21,500	27,880
32	7,300	8,030	8,905	11,825	15,330
56					
96					
	16 Draw	16 Draw	16 Draw	16 Draw	16 Draw
Q3	820	905	1,000	1,330	1,725
Q2	455	500	555	735	955
<b>DOUBLES DRAW SIZE</b>	<b>16 Draw</b>	<b>16 Draw</b>	<b>16 Draw</b>	<b>16 Draw</b>	<b>16 Draw</b>
<b>DOUBLES TOTAL</b>	<b>202,250</b>	<b>222,540</b>	<b>246,710</b>	<b>327,590</b>	<b>424,800</b>
W	74,620	82,100	91,030	120,850	156,740
F	33,670	37,040	41,100	54,540	70,720
S	15,880	17,460	19,370	25,720	33,350
Q	7,670	8,440	9,360	12,430	16,120
16	3,940	4,340	4,800	6,380	8,270
24/32					

Beijing  
Dubai  
Tokyo  
Acapulco  
Memphis  
Washington



## X. EXHIBITS

### PRIZE MONEY DISTRIBUTION 2012 ATP World Tour 500 - EUR

#### CONTRIBUTIONS:

ON - SITE	900,000	1,207,500	1,404,300	1,424,850	1,627,500
RETIREMENT	22,500	30,190	35,115	35,625	40,690
PLAYER PROMOTION	11,045	14,830	17,275	17,525	20,020
PLAYERS MONEY	866,455	1,162,480	1,351,910	1,371,700	1,566,790
SINGLES DRAW SIZE	32 Draw	32 Draw	32 Draw	32 Draw	56 Draw
SINGLES TOTAL	693,095	929,830	1,081,370	1,097,200	1,251,340
W	216,560	290,550	337,900	342,850	301,150
F	97,635	131,000	152,350	154,570	151,630
S	46,250	62,050	72,160	73,220	76,870
Q	22,315	29,940	34,820	35,330	38,960
16	11,380	15,265	17,755	18,010	20,000
32	6,260	8,395	9,765	9,910	10,530
56					6,320
96					
	16 Draw	16 Draw	16 Draw	16 Draw	28 Draw
Q3	705	945	1,100	1,115	630
Q2	390	525	605	615	315
DOUBLES DRAW SIZE	16 Draw	16 Draw	16 Draw	16 Draw	24 Draw
DOUBLES TOTAL	173,360	232,650	270,540	274,500	315,450
W	63,980	85,840	99,820	101,280	94,400
F	28,860	38,730	45,040	45,700	47,550
S	13,600	18,260	21,240	21,540	24,090
Q	6,570	8,830	10,260	10,410	12,210
16	3,380	4,530	5,270	5,350	6,260
24/32					3,300

Hamburg  
Rotterdam  
Basel  
Valencia  
Barcelona



## X. EXHIBITS

### PRIZE MONEY DISTRIBUTION 2012 ATP World Tour 1000 - USD

#### CONTRIBUTIONS:

ON - SITE	2,648,700	2,825,280	3,531,600	3,973,050	4,694,969
RETIREMENT	66,220	70,630	88,290	99,325	99,325
PLAYER PROMOTION	32,550	34,750	43,440	48,840	48,840
PLAYERS MONEY	2,549,930	2,719,900	3,399,870	3,824,885	4,546,804
SINGLES DRAW SIZE	48 Draw	56 Draw	56 Draw	96 Draw	96 Draw
SINGLES TOTAL	2,039,720	2,175,740	2,719,670	3,054,195	3,730,456
W	522,550	535,600	669,450	659,775	1,000,000
F	256,220	262,610	328,260	321,990	500,000
S	128,960	132,165	165,210	161,375	200,000
Q	65,575	67,205	84,000	82,270	100,000
16	34,050	34,900	43,625	43,370	43,520
32	17,950	18,400	23,000	23,210	23,291
56	9,695	9,935	12,420	12,530	12,725
96				7,680	7,709
	24 Draw	28 Draw	28 Draw	48 Draw	48 Draw
Q3	2,145	2,290	2,860	2,290	2,296
Q2	1,095	1,165	1,460	1,170	1,175
DOUBLES DRAW SIZE	24 Draw	24 Draw	24 Draw	32 Draw	32 Draw
DOUBLES TOTAL	510,210	544,160	680,200	770,690	816,348
W	155,490	165,860	207,320	216,190	241,000
F	76,120	81,200	101,500	105,500	121,000
S	38,180	40,730	50,910	52,880	55,000
Q	19,600	20,910	26,130	26,950	27,041
16	10,130	10,800	13,510	14,210	14,259
24/32	5,350	5,700	7,120	7,610	7,632

Canada  
Cincinnati  
Shanghai  
Miami  
Indian Wells



# X. EXHIBITS

PRIZE MONEY DISTRIBUTION		2012 ATP World Tour 1000 - EUR		
<u>CONTRIBUTIONS:</u>				
ON - SITE	2,427,975	2,427,975	3,090,150	
RETIREMENT	60,700	60,750	77,230	
PLAYER PROMOTION	29,840	29,870	38,010	
PLAYERS MONEY	2,337,435	2,337,355	2,974,910	
SINGLES DRAW SIZE	48 Draw	56 Draw	56 Draw	
SINGLES TOTAL	1,869,755	1,869,675	2,379,690	
W	479,000	460,260	585,800	
F	234,865	225,680	287,225	
S	118,210	113,580	144,560	
Q	60,110	57,755	73,510	
16	31,215	30,000	38,170	
32	16,460	15,810	20,125	
56	8,885	8,535	10,865	
96				
	24 Draw	28 Draw	28 Draw	
Q3	1,965	1,965	2,505	
Q2	1,000	1,000	1,275	
DOUBLES DRAW SIZE	24 Draw	24 Draw	24 Draw	
DOUBLES TOTAL	467,680	467,680	595,220	
W	142,500	142,500	181,400	
F	69,780	69,780	88,800	
S	35,000	35,000	44,550	
Q	17,970	17,970	22,860	
16	9,290	9,290	11,820	
24/32	4,900	4,900	6,240	



Paris  
Monte Carlo\*  
Rome  
Madrid

\* Monte Carlo does not contribute toward Bonus Pool

# X. EXHIBITS

PRIZE MONEY DISTRIBUTION		2012 ATP Challenger Tour - USD				
<u>TOURNAMENT CATEGORY</u>		35,000	50,000	75,000	100,000	125,000
<b>\$</b>						
TOTAL PRIZE MONEY IN SINGLES		35,000	50,000	75,000	100,000	125,000
DRAW SIZE	FINISH	26,230	37,500	56,250	75,000	93,750
	W	5,000	7,200	10,800	14,400	18,000
	F	3,000	4,240	6,360	8,480	10,600
	S	1,755	2,510	3,765	5,020	6,275
	Q	1,020	1,460	2,190	2,920	3,650
	16	600	860	1,290	1,720	2,150
	32	365	520	780	1,040	1,300
TOTAL PRIZE MONEY IN DOUBLES						
DRAW SIZE	FINISH	8,770	12,500	18,750	25,000	31,250
	W	2,200	3,100	4,650	6,200	7,750
	F	1,250	1,800	2,700	3,600	4,500
	S	760	1,080	1,620	2,160	2,700
	Q	450	640	960	1,280	1,600
	16	250	360	540	720	900

32

16

PRIZE MONEY DISTRIBUTION		2012 ATP Challenger Tour - EUR				
<u>TOURNAMENT CATEGORY</u>		35,000	50,000	75,000	100,000	125,000
<b>€</b>						
TOTAL PRIZE MONEY IN SINGLES		30,000	42,500	64,000	85,000	106,500
DRAW SIZE	FINISH	22,500	31,870	47,860	63,730	79,850
	W	4,300	6,150	9,200	12,250	15,300
	F	2,500	3,600	5,400	7,200	9,000
	S	1,500	2,130	3,250	4,260	5,375
	Q	875	1,245	1,850	2,480	3,100
	16	530	730	1,100	1,460	1,830
	32	310	440	660	885	1,110
TOTAL PRIZE MONEY IN DOUBLES						
DRAW SIZE	FINISH	7,500	10,630	16,140	21,270	26,650
	W	1,900	2,650	3,950	5,250	6,600
	F	1,100	1,500	2,350	3,100	3,850
	S	650	920	1,380	1,840	2,300
	Q	400	540	850	1,090	1,360
	16	200	310	460	610	770

32

16



## X. EXHIBITS

### EXHIBIT K - Schedule of Matches Suggested Tournament Schedule of Matches

28 Draw ATP World Tour 250 (16 Doubles)									
	SAT	SUN	MON	TUE	WED	THU	FRI	SAT	SUN
SINGLES	24	4	6	6	4	4	4	2	1
DOUBLES			2	2	4	3	2	1	1
TOTAL MATCHES	24	4	8	8	8	7	6	3	2
TOTAL COURTS	6	2	2	2	2	2	2	1	1

32 Draw ATP World Tour 250 (16 Doubles)									
	SAT	SUN	MON	TUE	WED	THU	FRI	SAT	SUN
SINGLES	24	4	8	8	4	4	4	2	1
DOUBLES			2	2	4	3	2	1	1
TOTAL MATCHES	24	4	10	10	8	7	6	3	2
TOTAL COURTS	6	2	3	3	2	2	2	1	1

48 Draw ATP World Tour 250 (16 Doubles)									
	SAT	SUN	MON	TUE	WED	THU	FRI	SAT	SUN
SINGLES	36	6	10	10	12	8	4	2	1
DOUBLES			3	3	2	2	2 or 3	1 or 2	1
TOTAL MATCHES	35	6	13	13	14	10	6 or 7	3 or 4	2
TOTAL COURTS	6 or 8	2	3 or 4	3 or 4	3 or 4	3	2	1	1

48 Draw ATP World Tour 500 (16 Doubles)									
	SAT	SUN	MON	TUE	WED	THU	FRI	SAT	SUN
SINGLES	12	6	10	10	12	8	4	2	1
DOUBLES			3	3	3	2	1 or 2	1 or 2	1
TOTAL MATCHES	12	6	13	13	15	10	5 or 6	3 or 4	2
TOTAL COURTS	3	2	3 or 4	3 or 4	4	3	2	1	1

48 Draw ATP World Tour Masters (24 Doubles)									
	SAT	SUN	MON	TUE	WED	THU	FRI	SAT	SUN
SINGLES	12	6	10	10	12	8	4	2	1
DOUBLES			4	4	4	4	4	2	1
TOTAL MATCHES	12	6	14	14	16	12	8	4	2
TOTAL COURTS	3	2	3 or 4	3 or 4	4	3	2	1	1

56 Draw ATP World Tour Masters 1000 (24 Doubles)									
	SAT	SUN	MON	TUE	WED	THU	FRI	SAT	SUN
SINGLES	14 (24)*	7 (4)*	14	14	12	8	4	2	1
DOUBLES			4	4	4	4	4	2	1
TOTAL MATCHES	14 (24)*	7 (4)*	18	18	16	12	8	4	2
TOTAL COURTS	4 (6)*	2 (3)*	4 or 5	4 or 5	4	3 or 4	2	1	1

\* ATP World Tour 250

## X. EXHIBITS

### Notes:

Factors that may necessitate a variance to the above may include, but are not limited to:

- 1) Court Availability
- 2) Hours of play available on each court
- 3) Availability of Officials

# X. EXHIBITS

## EXHIBIT L - Line Umpire Program

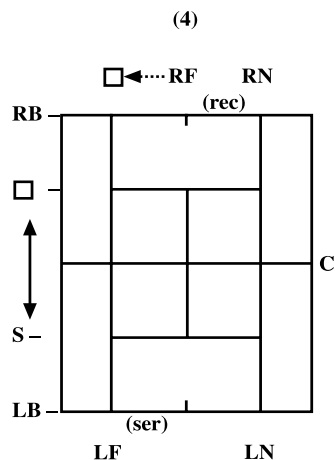
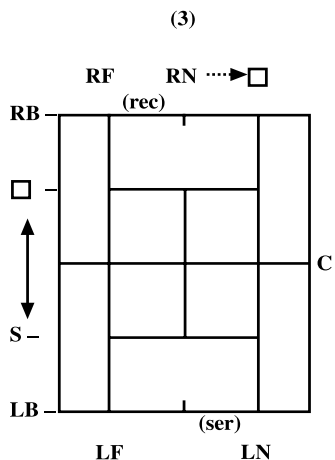
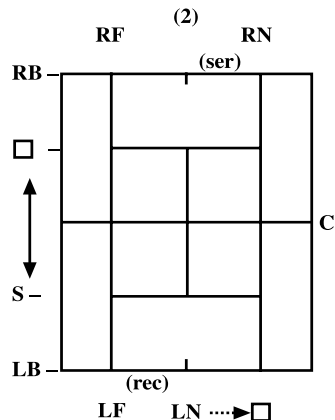
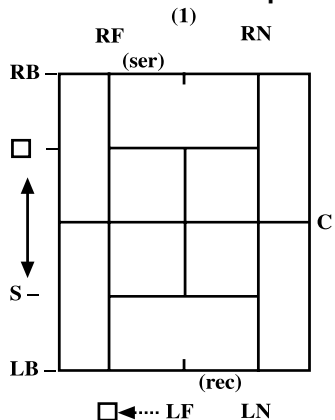

- 1) All center service and side lines are called only up to the net.
- 2) Serves are called from the receiver's end.
- 3) Line umpire moves from center service line after serve is put into play to his/her assigned line.
- 4) Service (S)umpire moves after "even" games and during tie-break (jumps serve).
- 5) Left base line (LB); right base line (RB); long line designations (e.g. LF=left far; LN=left near) are also in relation to the "Chair" (C).
- 6) In doubles, side service line umpire moves to doubles side line after the serve (other sideline umpires are "on" doubles line).

# X. EXHIBITS

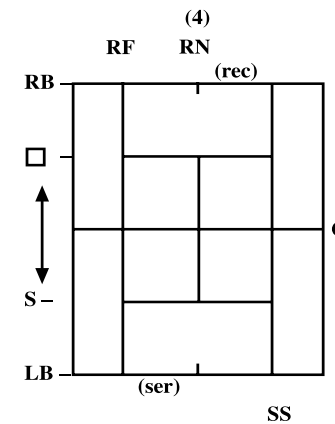
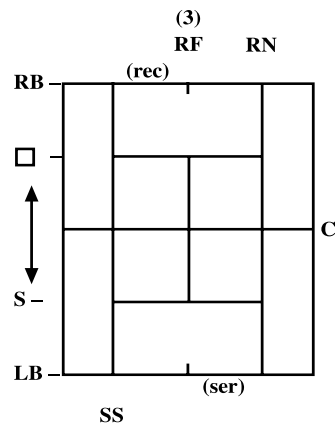
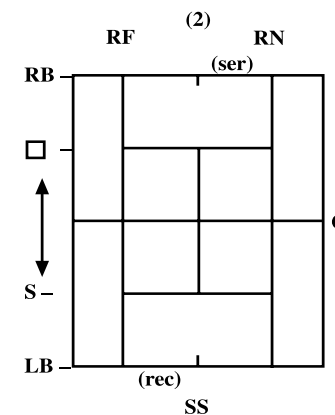
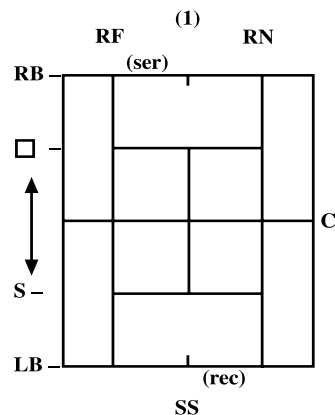

### Notes:

- 1) The side service lines are always called from the server's end of court.
- 2) Unless the sun is a factor, the "solo side" (SS) should be on the chair's left
- 3) There is no movement during play except in doubles when the side service line umpire moves to the doubles side line after the serve.
- 4) Service (S) umpire moves after "even" games and during tie-break (jumps serve.)
- 5) Left base line (LB); right base line (RB); long line designations (e.g. LF=left far; LN=left near) are also in relation to the "Chair" (C). All long line umpires move between points when the server serves from the left of the chair.
- 6) Center service line is always called from the receiver's end.

# X. EXHIBITS

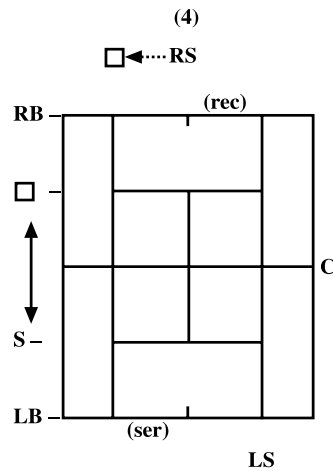
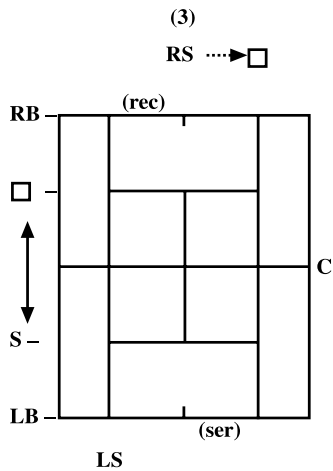
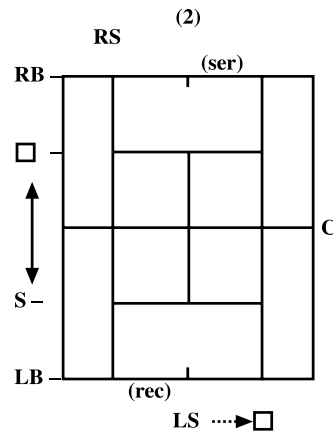
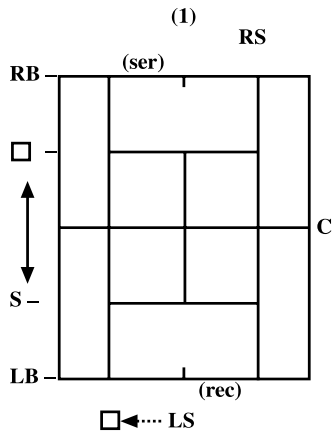

**Notes:**

- 1) The side service lines are always called from the server's end of court
- 2) The center service line is always called from the receiver's end of court and then the umpire moves after the serve is put into play to the uncovered side line (side farthest away from the receiver.)
- 3) Service (S) umpire moves after "even" games and during tie-break (jumps serve).
- 4) Left base line (LB); right base line (RB); long line designations (e.g. LF=left far; LN=left near) are also in relation to the "Chair" (C).
- 5) In doubles, side service line umpire moves to doubles side line after the serve.

# X. EXHIBITS

## EXHIBIT M - Point Penalty Card

Tournament City: Lisbon

ATP Official Point Penalty Record

Tournament: Tennis Masters Cup

Date: 27/11/00 Round: Final Chair Umpire: Fred Fair

Player(s): Steve Searle

Code Sequence	Time Sequence	Code	Score	Description
	Warning	6	01,15-15	didn't commence play in 25"
	Point	6	3-4	failed to serve in 90"
	Warning	3	4-4,15-30	yelled "shit" after losing pt.
	Point	2	4-6,02	broke racquet
	Point	6	4-6,6-5,15-0	didn't serve in 25"

Player(s): Dave Defaut

Code Sequence	Time Sequence	Code	Score	Description
	Warning	6	6-4,1-0	delayed server's pace
	Warning	2	6-4,2-2,0-5	dangerously threw racquet
	Point	7	6-4,3-4	berated the umpire
	game penalty	5	6-4,5-7,5-5	broke racquet

If necessary, use Reverse Side for Additional Details of the Violation(s)

**Code Violations**

1 Abuse of Balls	4 Coaching	7 Unsportsmanlike Conduct
2 Abuse of Racquets or Equipment	5 Physical Abuse	8 Verbal Abuse
3 Audible Obscenity	6 Unreasonable Delays	9 Visible Obscenity

27/11/00 Date

Fred Fair Signature of Chair Umpire

PRO-38  
1 Jan 00

# X. EXHIBITS

## EXHIBIT N - Scorecard

Time Started		Time Finished		Tie Break		Games		Games	
1:00 pm						A		B	
BC	Serves	Points		Set Number 1		A	B	A	B
1	A	/	/	/	/	1	0	1	
2	B	/	/	/	/	1	1	1	
3	A	A	A	A	A	2	1	2	
4		D	C	D					
5									
6									
7									
8									
9									
10									
11									
12									
13	Tiebreak								

Player(s)

Player(s)

The Scorecard shows in the first game the score ran and would have been called thusly: "15-love, 15-all, 30-15, 30-all, 40-30, deuce, advantage (A), deuce, advantage (A), game (A)." In the Second game: "15-love, 15-all, 30-15, 30-all, 40-30, deuce, advantage (B), game (B)," and so on.

# X. EXHIBITS

## EXHIBIT O - Glossary

### Draw Results:

The supervisor must record match results using, where appropriate, the following definitions:

**Abandoned:** Match began but was not completed for any reason other than default or retirement. There is no winner or loser. The match is not to be completed. Players receive points and money equivalent to loser of that round.

**Default:** Losing player was defaulted under provisions of Code of Conduct after match had begun.

**Incomplete:** Match began but was not completed for any reason other than weather, default, or retirement. There is no winner or loser. It is anticipated that the match will be resumed and completed.

**Retired:** Losing player retired because of illness or injury after match had begun.

**Unplayed:** Match did not begin for any reason other than (a) illness or injury on the part of one player or (b) one player was subjected to penalties of Code of Conduct before first serve of match was struck or otherwise not permitted by the ATP or tournament supervisor from playing. There is no winner or loser and the match will not be played.

**Walkover:** Match did not begin because:

- a) losing player was ill or injured or
- b) losing player was subjected to penalties of Code of Conduct before first serve of match was struck or otherwise not permitted by the ATP or tournament supervisor from playing.

This would not be used when a lucky loser or alternate is substituted. Winners of "walkover" matches receive points and prize money as if the match had been played. Losers of "walkover" matches receive points and prize money for round reached unless this was their first match of the event. In that case, no points or prize money is awarded. In the case of ATP Challenger Tour doubles, withdrawing teams receive points and money from the previous round.

**Weather:** Match began but was not completed because of inclement weather. There is no winner or loser. It is anticipated that the match will be resumed and completed.

### Miscellaneous Definition of Terms

**Alternate:** The next highest ranked player(s) who were not a direct acceptance at the time of the entry deadline.

**ATP Player Dues:** Money owed or collected for ATP player membership or the annual dues of such membership.

**South African Airways ATP Rankings:** The objective merit-based method used for determining qualification for entry and seeding in all tournaments for both singles and doubles, except as modified for World Team Championship, and the Barclays ATP World Tour Finals (singles & doubles).

**Ball Mark Inspection (BMI):** On clay courts the chair umpire may leave the chair

## X. EXHIBITS

and inspect the mark left by the ball in play to determine the correctness of the call. This can only be done after a point-ending shot or if the player or team stops play to request an inspection.

**Ceremonies:** Awards presentations customarily held following the conclusion of the final championship match(es).

**Chair Umpire:** This official is responsible for the conduct of the match. His main duties are to enforce all ATP Rules and Regulations and on-court procedures to ensure accuracy, fairness and safety. He is the final authority on all questions of fact that may arise during the match.

**Direct Acceptance:** Players or teams accepted directly in the draw by virtue of their position in the South African Airways ATP Rankings (singles) or ATP Doubles Rankings System or by their protected ranking.

**Late Withdrawal:** Player withdraws after 12 Noon PVB time on the Friday prior to the event; or player does not appear for his match and is not on site.

**Late Withdrawal, Qualifying:** This applies to ATP World Tour Masters 1000 and ATP World Tour 500 events where there is an advance acceptance list for the qualifying and the player withdraws after the deadline.

**Line Umpire:** Officials responsible for calling specific assigned lines according to the ATP Rules under the direct on-court supervision of the chair umpire.

**Lucky Loser:** Players who have lost in the final round of qualifying, or if needed, earlier rounds. These players are placed in rank order and may become eligible to replace any player in the main draw who is forced to withdraw prior to his first match.

**Major Offenses:** aggravated behavior, Bribes or Other Payments, Conduct Contrary to the Integrity of the Game, Prohibited Promotional Fees and Wagers. A Major Offense is initiated and investigated by the Executive Vice President - Rules & Competition and is in addition to any penalties that may have been levied by the on site supervisor.

**Medical Time-Out (MTO):** Official time allotted during the match for treatment due to an approved medical condition. The treatment is given by the ATP physio-therapist. The time allowed is 3 minutes (4 1/2 if taken on a changeover) for each separate medical condition.

**No Show:** Player does not appear for his first match and there has been no contact or prior notification from the player that he would not appear for the match. For penalty purposes, this would be penalized as a "Late Withdrawal".

**Non-Member Service Fee:** Players who are not members in good standing of the ATP must pay a fee for services rendered. This applies to main draw players at all ATP World Tour Masters 1000 or ATP World Tour 500 and ATP World Tour 250 events and to qualifying players at ATP World Tour Masters 1000 and ATP World Tour 500 events. This does not apply to the Challenger Circuit.

**On-Site Withdrawal (ATP World Tour):** Player withdraws after 12 Noon Eastern time, USA on Friday and was on-site at the event when the withdrawal occurred and is determined to be unfit for play by that tournament's doctor. Players still competing in a tournament or Davis Cup match after the 12 Noon deadline and are forced to withdraw/retire, from a match may be examined by that event's

## X. EXHIBITS

doctor and shall then be considered the same as an On-Site Withdrawal. Withdrawals/Retirements from Davis Cup must be from "live" matches and include a medical certification from the Independent Doctor. This should be documented on the withdrawal summary from the tournament that the player withdrew from.

**On-Site Withdrawal (ATP Challenger Tour or ATP World Tour Masters 1000/ ATP World Tour 500 Qualifying):** Player withdraws after the 12 Noon Friday deadline and is examined at the tournament site within the first three (3) days of the event, or in the case of ATP World Tour Masters 1000 and ATP World Tour 500 qualifying on the Saturday or Sunday of qualifying. Players still competing in a tournament or Davis Cup match after the 12 Noon deadline and are forced to withdraw/retire, from a match may be examined by that event's doctor and shall then be considered the same as an On-Site Withdrawal. Withdrawals/Retirements from Davis Cup must be from "live" matches and include a medical certification from the Independent Doctor. This should be documented on the withdrawal summary from the tournament that the player withdrew from.

**Protected Ranking:** A ranking assigned a player who has been unable, due to injury, to compete in any tennis event for a minimum of six (6) months.

**Punctuality:** Player fails to appear, in a timely manner, when his match has been called. Provisions for Non-Appearance do not apply.

**Qualifier:** Player who has won his place into the main draw by way of a qualifying competition.

**Qualifying Non-Appearance:** A player is entered into the qualifying through the supervisor of another event and does not appear for his match. This also includes players accepted into the qualifying as a wild card who do not appear for their match. This includes those who sign-in through the supervisor as an alternate to ATP World Tour Masters 1000 and ATP World Tour 500 qualifying. It also covers ATP Challenger Tour events.

**Referee:** Official hired by the tournament to advise in planning the event and assist the ATP supervisor in his assigned duties and responsibilities.

**Review Official:** Official hired by the ATP who is responsible for the Review function of Electronic Line Calling systems on site.

**Seed:** Players who are given preferential positions in the draw based on the ATP Ranking System.

**Special Event:** Those events other than Grand Slams, ATP World Tour tournaments, ATP Challenger Tour tournaments and Futures.

**Special Exempt:** Player accepted into the main draw who was still competing in the singles event of another qualified event at the time of this event's qualifying. Player may not have been accepted as a direct acceptance, if entered.

**Special Exempt /Wild Card Non-Appearance:** A player accepts a SE or WC and does not appear for his match and is not on site. This violation would be considered as a Late Withdrawal and be subject to the penalties set forth under Late Withdrawal.

**Supervisor:** Final on-site authority ensuring that the tournament is conducted fairly in accordance with the ATP's Rules and Regulations as to all matters arising that require immediate resolution.

## X. EXHIBITS

**Tour Manager:** Represents the player's interests in all matters involving the sign-ins, draws and the scheduling of the event.

**Tournament Director:** Person representing the owners of the event in the day-to-day management of the tournament.

**Wild Card:** Players included in the draw at the sole discretion of the tournament. A specified number of wild cards are available in each event.

**Withdrawal:** Player who withdraws after the entry deadline but prior to 12 Noon (PVB) on the Friday prior to the event.

## X. EXHIBITS

### EXHIBIT P - Chief of Umpires

The Chief of Umpires shall:

**1) Be prepared to brief the supervisor and referee on:**

- a) The plan for implementing the officials.
- b) The tournament support of the officials (facilities, telephone and other communication devices, food and beverage, uniforms, parking, stadium seating, transportation, housing, etc.).

**2) Discharge the following responsibilities:**

- a) Pre-tournament.
  - i) Recruit a sufficient number of competent officials who are qualified to officiate at this level of event. The most qualified officials must be assigned through the finals. Prepare a list of officials (line umpires with ratings, chair umpires with ratings) for the full-time ATP official coordinating the officials for the event.
  - ii) If applicable, negotiate a contract or agreement for officials with the tournament.
  - iii) If a Challenger event, submit to the ATP a list of proposed Designated chair umpires no less than 90 days prior to the start of the tournament.
  - iv) If requested by the tournament, provide a list of officials to the Chairperson responsible for the program.
  - v) Compile an officials' clothing sizes list, in case the tournament furnishes clothing for uniforms.
  - vi) Conduct the necessary pre-tournament training of officials including review of the Rules of Tennis, ATP tournament Rules and Code.
  - vii) Check with the tournament about arrangements for:
    - o umpire chairs
    - o cushions//sunshades
    - o singles sticks
    - o chairs for use on--court by line umpires
    - o scorecards
    - o scoreboards//personnel
    - o new and used balls
  - viii) Check supplies for the tournament:
    - o scorecards
    - o clipboards (if needed)
    - o point penalty forms
    - o first aid kit
    - o pencils
    - o office supplies
    - o crew rotation forms
    - o on-court line umpire evaluation forms
  - ix) Complete the standard portion of the scorecards.
  - x) Check all applicable arrangements for officials:
    - o on--site office and lounge
    - o transportation (long-distance or local)
    - o food and beverages
    - o parking
    - o telephones
    - o housing
    - o security
    - o toilets
    - o photocopier
    - o walkie--talkies
  - xi) Prepare a check-in form if the number of officials requires it.
  - xii) Organize a method of notification or a mailing that informs all of the officials about the tournament dates, officials report times (no less than 30 minutes before start of play), uniform requirements and arrangements for transportation, parking and housing. An umpire information sheet is recommended for an event larger than a 32 draw.

## X. EXHIBITS

- xiii) Present to the ATP supervisor during the qualifying sign-in:
  - o a roster of all officials to be used during the tournament (include name, mailing address and national or local certifications if any).
  - o an availability list of the line umpires for each day. Note anticipated number of courts and officials assigned for each day. Note that the most qualified must be assigned through the finals. All assignments are subject to the approval of the ATP supervisor.
  - o an availability list of the chair umpires for each day (include designated chairs if an ATP Challenger Tour tournament). Categorize according to rating, experience and ability.
- b) During the Tournament:
  - i) Provide assistance to the ATP supervisor as needed.
  - ii) Be on site at all times during play. The Chief of Umpires may not be a chair umpire or line umpire unless authorized by the ATP supervisor.
  - iii) Instruct the officials on the tournament procedure for handling new and used balls.  
Note that it is inappropriate for the chair umpires to supply the court with the balls for their matches.
  - iv) Instruct the officials on the procedure for reporting and turning in both scorecards and point penalty forms. Point penalty forms must not be turned in to the press room or made available to the press. Chair umpires will report incidents recorded on their point penalty forms to the ATP supervisor or his designee.
  - v) Obtain the order of play for the following day and be prepared to recommend chair umpire assignments, if requested to do so by the ATP supervisor.
  - vi) Assist the ATP supervisor to ensure that the same chair umpire is not assigned to the same player consecutively. Take care that a player losing in one event does not have the same chair umpire for his next match in the other event. The Chief of Umpires should prepare and keep current for this purpose draw sheets with the chair umpire assignments.
  - vii) Schedule the on-court assignment of the line umpires, subject to the approval of the ATP supervisor, line umpires for the quarterfinals, semifinals and finals must have worked a minimum of two (2) days prior to the quarterfinal and must have demonstrated that their skills merit the assignment.
- c) Observe the performance of all officials during the matches.
- d) Remove, rotate or replace a line umpire whenever it is necessary to improve the officiating of a match.
- e) Maintain the ATP line umpire evaluation process, and make ongoing assignments based upon evaluations.
  - i) Be prepared for other contingencies (such as rain) that may change the number of courts being used.
  - ii) Prepare a day in advance, recording chair umpire assignments on the order of play and preparing rotations for the line teams.  
Complete information must be posted before the arrival of the officials the next day, no less than 30 minutes before the start of play.
  - iii) Conduct a daily meeting with all officials.
- f) Post-Tournament.  
Prepare a written report for the supervisor. Include recommendations for improvements and the prevention of problems.

## X. EXHIBITS

### EXHIBIT Q - Special Exempts

For the purpose of the ATP Challenger Tour special exempt rule, a geographic region is defined as follows:

#### Region I -

##### Americas.

This region includes the following countries:

##### North America -

Canada, United States (including Hawaii) and Mexico

##### Central America and the Caribbean -

Anguilla (UK), Antigua and Barbuda, Aruba (Neth.), Bahamas, Barbados, Belize, Bermuda (UK), British Virgin Islands (UK), Cayman Islands (UK), Costa Rica, Cuba, Dominica, Dominican Republic, El Salvador, Greenland (Den.), Grenada, Guadeloupe (Fr.), Guatemala, Guyana, Haiti, Honduras, Jamaica, Martinique (Fr.), Montserrat (UK), Netherlands Antilles (Neth.), Nicaragua, Panama, Puerto Rico (U.S.), St. Kitts and Nevis, St. Lucia, St.-Pierre and Miquelon (Fr.), St. Vincent and the Grenadines, Trinidad and Tobago, Turks and Caicos Islands (UK), Virgin Islands (U.S.).

##### South America -

Argentina, Bolivia, Brazil, Chile, Colombia, Ecuador, Falkland Islands (UK), French Guiana (Fr.), Paraguay, Peru, Suriname, Uruguay, Venezuela.

#### Region II -

##### Europe, Africa, Middle East, Western part of Russia and some Western Asia countries.

This region includes the following countries:

##### Europe -

Albania, Andorra, Austria, Belarus, Belgium, Bosnia-Herzegovina, Bulgaria, Channel Islands (UK), Croatia, Czech Republic, Denmark, Estonia, Finland, France, Germany, Gibraltar (UK), Greece, Hungary, Iceland, Ireland, Italy, Latvia, Liechtenstein, Lithuania, Luxembourg, Macedonia, Malta, Moldova, Monaco, Netherlands, Norway, Poland, Portugal, Romania, San Marino, Slovakia, Slovenia, Spain, Sweden, Switzerland, Ukraine, United Kingdom, Vatican City, Yugoslavia.

##### Africa -

Algeria, Angola, Azores (Port.), Benin, Botswana, Burkina Faso, Burundi, Cameroon, Canary Islands (Sp.), Cape Verde, Central African Republic, Chad, Comoros, Congo, Côte d'Ivoire, Democratic Republic of the Congo, Djibouti, Egypt,

## X. EXHIBITS

Equatorial Guinea, Eritrea, Ethiopia, Gabon, Gambia, Ghana, Guinea, Guinea-Bissau, Kenya, Lesotho, Liberia, Libya, Madagascar, Madeira (Port.), Malawi, Mali, Mauritania, Mauritius, Mayotte (Fr.), Morocco, Mozambique, Namibia, Niger, Nigeria, Reunion (Fr.), Rwanda, Sao Tome and Principe, Senegal, Seychelles, Sierra Leone, Somalia, South Africa, Sudan, Swaziland, Tanzania, Togo, Tunisia, Uganda, Western Sahara, Zambia, Zimbabwe.

### Middle East -

Armenia, Azerbaijan, Bahrain, Cyprus, Gaza Strip (Israeli-occupied terr.), Georgia, Iran, Iraq, Israel, Jordan, Kuwait, Lebanon, Oman, Qatar, Saudi Arabia, Syria, Turkey, United Arab Emirates, West Bank (Israeli-occupied terr.), Yemen.

### Western Asia -

Afghanistan, Kazakhstan, Kyrgyzstan, Pakistan, Tajikistan and Turkmenistan..

### Western Russia -

Includes Moscow, St. Petersburg, Togliatti and Uzbekistan.

### Region III -

#### Eastern part of Asia and Oceania.

This region includes the following countries:

#### Eastern Asia -

Bangladesh, Bhutan, Brunei, Cambodia, China, Guam (U.S.), India, Indonesia, Japan, Korea, Laos, Malaysia, Maldives, Mongolia, Myanmar, Nepal, Northern Mariana Islands (U.S.), Palau, Philippines, Eastern Russia, Singapore, Sri Lanka, Taiwan, Thailand, Vietnam.

#### Oceania -

American Samoa (U.S.), Australia, Cook Islands (N.Z.), Fiji, French Polynesia (Fr.), Kiribati, Marshall Islands, Micronesia, Nauru, New Caledonia (Fr.), New Zealand, Niue (N.Z.), Papua New Guinea, Pitcairn Islands (UK), Samoa, Solomon Islands, Tokelau (N.Z.), Tonga, Tuvalu, Vanuatu, Wallis and Futuna (Fr.).

## X. EXHIBITS

### EXHIBIT R - Consent and Agreement Form

#### PLAYER'S CONSENT AND AGREEMENT TO THE ATP OFFICIAL RULEBOOK, INCLUDING THE UNIFORM TENNIS ANTI-CORRUPTION PROGRAM & TENNIS ANTI-DOPING PROGRAM

I, the undersigned player, acknowledge, consent and agree as follows:

1. I will comply with and be bound by all of the provisions of the 2012 ATP OFFICIAL RULEBOOK and the ATP Tour, Inc.'s ("ATP") By-Laws (the "ATP Rules"), including, but not limited to, all amendments to the ATP Rules. I have received and had an opportunity to review the ATP Rules.
2. I acknowledge that the ATP has a Uniform Tennis Anti-Corruption Program and the program rules are included in the 2012 ATP OFFICIAL RULEBOOK. I accept that I must comply with and be bound by all provisions included in the Uniform Tennis Anti-Corruption Program. The Uniform Tennis Anti-Corruption Program prohibits certain conduct by me and my "related persons", as defined in the rule, including, but not limited to, (i) wagering on any tennis match, (ii) contriving or attempting to contrive the outcome of any tennis match, (iii) providing for consideration information concerning the condition or status of players, and (iv) the failure to report to the Professional Tennis Integrity Officer as soon as possible any knowledge I may have regarding potential violations of the Uniform Tennis Anti-Corruption Program. Nothing in this paragraph 2 shall modify or limit the full text of the Uniform Tennis Anti-Corruption Program.
3. The International Tennis Federation ("ITF") may conduct anti-doping testing at ATP sanctioned events under the Tennis Anti-Doping Program (the "Anti-Doping Program"), a copy of which is available upon request from the ITF or may be downloaded at <http://www.itftennis.com/antidoping/>. ATP will honor and enforce any penalties or sanctions against me resulting from the Anti-Doping Program. The Anti-Doping Program shall apply to and be binding upon me and shall govern participation in the events specified at Article B of the Anti-Doping Program, which includes all ATP-sanctioned events (including Challenger events). I hereby submit to the jurisdiction and authority of the ITF to manage, administer and enforce the Anti-Doping Program and to the jurisdiction and authority of the Anti-Doping Tribunal and the Court of Arbitration for Sport ("CAS") to determine any charges brought under the Anti-Doping Program. I also hereby give my consent to the release to ATP of my Anti-Doping results obtained by the ITF at ATP events, including missed tests and / or filing failures.
4. Any dispute arising out of any decision made by the Anti-Doping Tribunal, or any dispute arising under or in connection with the Anti-Doping Program, after exhaustion of the Anti-Doping Program's Anti-Doping Tribunal process and any other proceedings expressly provided for in the Program, shall be submitted exclusively to the Appeals Arbitration Division of the CAS for final and binding arbitration in accordance with Article O of the Anti-Doping Program and CAS's Code of Sports-Related Arbitration. The decisions of CAS shall be final, non-reviewable, non-appealable and enforceable. I agree that I will not bring any claim, arbitration, lawsuit or litigation in any other court or tribunal. The time limit for any submission to CAS shall be 21 days after the decision of the Anti-Doping Tribunal has been communicated to me.



## X. EXHIBITS

5. Any dispute between or among the ATP and me arising out of the application of any provision of the 2012 ATP Official Rulebook which is not finally resolved by applicable provisions of such Rulebook shall be submitted exclusively to CAS for final and binding arbitration in accordance with CAS's Code of Sports-Related Arbitration. The decision of CAS in that arbitration shall be final, non-reviewable and enforceable. No claim, arbitration, lawsuit or litigation concerning the dispute shall be brought in any other court or tribunal. Any request for CAS arbitration shall be filed with CAS within 21 days of any action by the ATP which is the subject of the dispute. In the event any provision of this clause is determined invalid or unenforceable, the remaining provisions shall not be affected. This clause shall not fail because any part of the rule is held invalid.
6. I acknowledge that the Notice of Privacy Practices is set forth in the ATP Rule Book and is available online on the ATP website, <https://atp-playerzone.com> and I also acknowledge that I have reviewed the same and agree to the terms and conditions contained therein.
7. I have read and understand the foregoing Player's Consent and Agreement.

_____	_____
Date	Print Player's Name (Last Name, First Name)
_____	_____
Player's Date of Birth (Day/Month/year)	Player's Signature and
_____	_____
Place of Birth	If player is a minor, signature of player's parent or guardian
_____	_____
	Player's Nationality

if sent via Facsimile, send to: +1 (904) 779 3300

## X. EXHIBITS

### EXHIBIT S - Privacy Notice ("HIPPA")

#### NOTICE OF PRIVACY PRACTICES AND CONSENT

This notice is being provided in connection with the Health Insurance Portability and Accountability Act of 1996 ("HIPAA"). Although the ATP is not bound to comply with all aspects of HIPAA, the ATP is committed to making sure that players are aware of the manner in which personal health information will be used, maintained and released.

**THIS NOTICE DESCRIBES HOW THE ATP TOUR (the "ATP"; FOR THE PURPOSES OF THIS EXHIBIT S, INCLUDED IN THE DEFINITION OF "ATP" SHALL BE NON-ATP EMPLOYED STAFF AT CHALLENGER TOURNAMENTS WHO PROVIDE MEDICAL ASSISTANCE) MAY USE AND DISCLOSE YOUR MEDICAL INFORMATION, AND HOW YOU CAN GAIN ACCESS TO YOUR PERSONAL AND PROTECTED HEALTH INFORMATION ("PHI"); PLEASE REVIEW CAREFULLY.**

The ATP is committed to maintaining the confidentiality of your PHI, in accordance with applicable federal and applicable state privacy laws, as well as our own company privacy policies. This notice describes how we may use and disclose your PHI and explains your legal rights regarding PHI. This notice also describes certain risks associated with Players and others utilizing a Tournament Training Room or other facility.

When we use the term "PHI", we mean information about you, including any health care payment, medical or demographic information that can reasonably be used to identify you and relates to your medical history. This includes, but is not limited to, injuries, illnesses, sickness, diseases, health care providers and laboratory and other test results.

This notice is effective on January 1, 2010. The terms of this notice apply to all records containing your PHI that are created or retained by the ATP. We reserve the right to revise or amend this notice. Any revision or amendment to this notice will be effective for all of your records that the ATP has created or maintained in the past, and for any of your records that the ATP may create or maintain in the future. You will find this and any revised or amended notices posted at the ATP's offices in Ponte Vedra Beach, Florida in a visible location, as well as on the PlayerZone website located at: <https://atp-playerzone.com>.

#### HOW THE ATP MAY USE AND DISCLOSE YOUR PHI

In order to provide you with certain health and other services, we may create or receive PHI relating to you. In coordinating and administering services, we may use and disclose your PHI in various ways, including:

- 1) **Treatment.** The ATP may use your PHI to assist in your treatment by providers. For example, a physiotherapist or the medical director of a tournament may access your PHI to understand and better treat your condition.
- 2) **Health Care Operations.** We may use and disclose PHI during the course of managing our business. For example, we may use your PHI to internally evalu-

## X. EXHIBITS

ate the quality of care that you received, to conduct internal company audits, for data information systems management, to conduct company cost management assessments, for evaluations and for general business planning purposes.

- 3) **Payment.** Your PHI may be requested by a third party for billing purposes, with regard to services provided to you, to conduct utilization and medical necessity reviews, to coordinate care with your health care insurance company or carrier, to calculate cost sharing amounts, and to respond to audits or reviews by federal or state government agencies, insurance companies or carriers.
- 4) **Qualified Service Organizations and Business Associates.** We may share your PHI with qualified service organizations, national federations or business associates who provide services to the ATP. In each case, these entities will have agreements with us to safeguard and keep confidential your PHI. We will only share the minimum PHI necessary for these entities to carry out their duties to the ATP.
- 5) **Patient Information Purposes.** We may use your PHI to inform you about potential treatment alternatives or options, and to notify you of other health related benefits and services that may be of interest to you.
- 6) **Disclosures in Accordance with Florida Law, Required by Law and Governing Law.**

By signing the Player's Consent and Agreement to the ATP Official Rulebook, you are agreeing that, for purposes of medical consent and release of records, the laws of the State of Florida shall govern. Certain disclosures of your PHI may be required by laws. These include, but are not limited to: (A) reports to federal, state or local law enforcement in connection with crime or threats to commit crime; (B) reports to appropriate state agencies in connection with reporting child abuse or neglect; (C) reports in connection with medical emergencies, for the purpose of treating conditions which pose an immediate threat to the health of any individual or which require immediate medical attention; (D) reports in response to court orders, if you are involved in a lawsuit or similar proceeding, or in response to a subpoena if you give us written authorization to release your PHI; (E) reports in connection with public health risk management (e.g., reporting of adverse drug reactions, notifications for recalled products or devices, required reports for certain diseases).

- 7) **Serious Threats to Health or Safety.** We may disclose your PHI as necessary to reduce or prevent a serious threat to your health and safety, or the health and safety of another individual or the public. Under these circumstances, we will only make disclosures to such persons or organizations able to help prevent such threat.

In all other situations, we will ask for your written authorization before disclosing your PHI. If you have given us an authorization, you may revoke it at any time, if we have not already acted on it. Revocation of consent is effective upon receipt of written notice, mailed via certified mail, return receipt requested and addressed to Andre Silva, Chief Player Officer, 201 ATP Tour Boulevard, Ponte Vedra Beach, Florida 32082, with a copy (sent certified mail, return receipt requested) to Jeffrey T. Reel, 201 ATP Tour Boulevard, Ponte Vedra Beach, Florida 32082. Revocation of this consent does not affect the validity of any prior use or disclosure of your PHI. You further understand that your right to revoke this authorization shall not serve to excuse any failure by you to comply with the provisions of the ATP Tour

## X. EXHIBITS

Official Rule Book covering my affiliation with the ATP Tour, or any other rule or agreement that may govern the terms and condition of your participation in tournaments.

### YOUR LEGAL RIGHTS REGARDING PHI

HIPAA gives you certain rights with respect to your PHI. You have the right to:

- Ask us to communicate with you in a certain way or at a certain location. We will accommodate reasonable requests.
- Request that we restrict the way we use or disclose your PHI in connection with health care operations, payment and treatment. We will consider, but may not agree to, such requests. You also have the right to ask us to restrict disclosures to persons involved in your health care.
- Obtain a copy of certain portions of your PHI, subject to applicable federal, state and local laws, rules and regulations. We may ask you to make your request in writing, may charge a reasonable fee for producing and mailing the copies, and in certain cases may deny the request.
- Amend PHI that you believe to be incorrect. Your request must be in writing and must include the reason for the request. If we deny the request, you may file a written statement of disagreement.
- Have us provide you with a list of certain disclosures of PHI we have made about you. Your request must be in writing. If you request such an accounting more than once in a twelve month period, we may charge a reasonable fee.
- File a complaint if you think your privacy rights have been violated. You will not be penalized or retaliated against for filing a complaint. To file a complaint, you must contact the United States Department of Health and Human Services, Office of Civil Rights. For more information about how to file a complaint, please visit [www.hhs.gov/ocr/hipaa](http://www.hhs.gov/ocr/hipaa).

By signing the Player's Consent and Agreement to the ATP Official Rulebook, you acknowledge that any health information that is disclosed in accordance with this authorization form might be redisclosed by the recipient of that information and may no longer be protected by federal healthcare privacy laws and rules.

If you have questions regarding your PHI, confidentiality of your PHI, or this Notice, please contact:

ATP Tour, Inc.

Attn: Andre Silva, Chief Player Officer

201 ATP Tour Blvd

Ponte Vedra Beach, Florida 32082

### GENERAL PRIVACY CONSIDERATIONS RELATING TO TRAINING ROOMS AND TREATMENT ROOMS

This notice also is intended to remind you that the ATP Training and/or Treatment Rooms and the Training/Treatment Rooms provided at the Tournaments are not designated as a private area. Should you choose to receive treatment there, or discuss confidential information (health or otherwise), it is possible that this information may be overheard by individuals that have no obligation to refrain from

## X. EXHIBITS

further disclosure of such information. Access to these areas is not limited to ATP personnel. Players are reminded of their duties and obligations arising from the ATP Rules and Anti-Coercion Policy. The information discussed, as well as photographic images also may be intercepted by electronic surveillance devices including but not limited to digital and other cameras, video cameras, cellular telephones and personal data devices. Neither the Tournament nor the ATP is responsible for the unauthorized capturing of any PHI or other personal/confidential information or the subsequent disclosure of the same.

Should you wish to ensure the confidential nature of health or other information, we encourage you to receive treatment in a secure environment of your choosing.

## X. EXHIBITS

### EXHIBIT T - Player Food Service

#### Recommendations for Player Food Service Planning

A. Player food should be prepared simply, with few sauces or spices. The following is a list of recommended food groups:

- 1) **Carbohydrates** (60% of total calorie intake)
  - a) **Breads and Starches**  
Assorted multi-grain breads and rolls, bagels, crackers, low-sugar cereals, pasta (with all sauces on the side), baked (white and sweet) potatoes (with selection of toppings) and rice (preferably brown or wild).
  - b) **Fruits and Vegetables**  
Assorted fresh fruit salad, dried fruits, whole fresh fruits, and fresh cut raw vegetables. Salad bar: tomatoes, potatoes, lettuce (variety), cucumbers, sprouts, mushrooms, carrots, peas, beans, etc. with oil and vinegar-based dressings on the side.
- 2) **Proteins** (15% of total calorie intake)  
Chicken (white meat), turkey (white meat), fish (assorted variety), soft low-fat cheeses, low fat cottage cheese, low fat yogurt, hard-boiled eggs, tofu, non-fat milk. Additional recommendations are soy milk and assorted nuts.
- 3) **Miscellaneous**
  - a) Broth-based soups, (e.g., minestrone, chicken noodle, vegetable).
  - b) All sauces should be served on the side (in a warmer if necessary).
  - c) Low-fat cooking methods should be used (baked, broiled and roasted, with limited butter and oils).
  - d) Seasonings should be light; offer extra salt, pepper, garlic, etc. on the side.

#### B. Daily Meal Planning

- 1) When providing meals, a variety of food choices are preferred on a daily basis.
- 2) In addition to daily meals, snacks should be provided throughout the day and evening (e.g., fruits, breads and rolls, cheeses, yogurts, nuts, crackers and raisins, etc.).
- 3) If morning practices and matches are played, breakfast items should also be available (e.g., cold cereals, bagels and breads, yogurt, fruit).
- 4) Suggested lunch and dinner menus should include Carbohydrates (bread/pasta/potatoes/rice) and at least two (2) protein selections (one [1] chicken and the other fish, meat, turkey or tofu).
- 5) Practice hours and match schedule will determine when meals and/or snacks are served. Allow for during playing hours, and up until the last match has gone on court.
- 6) Each tournament may contact the ATP Sport Medicine Department for menu recommendations and/or review.

## X. EXHIBITS

### EXHIBIT U - Player Medical Facility Guidelines

#### Player Treatment Area

The treatment room should be located near the locker room. It should be a private room for the players. If this room is not adjacent to the locker room and is free standing, a security guard should be checking for correct credentials before admittance.

#### Items to be supplied in Player Treatment Room

##### For a 32 draw:

- 1 adjustable high/low treatment table
- 2 fixed treatment tables for massage and taping
- 2 adjustable height stools on casters

##### For a 48 draw:

- 2 adjustable high/low treatment tables
- 2 fixed treatment tables for massage and taping
- 2 adjustable height stools on casters

##### For a 64 draw:

- 2 adjustable high/low treatment tables
- 3 fixed treatment tables for massage and taping
- 3 adjustable height stools on casters

##### For a 96 draw:

- 3 adjustable high/low treatment tables
- 4 fixed treatment tables for massage and taping
- 4 adjustable height stools on casters

#### Towels:

- Standard bath size (1.2m long by 60cm width)
- Assure that there is sufficient supply each day of tournament.
- Need bags with racks to hold soiled towels

#### Clean Ice, Bottled Water, Bottled Sports Drinks:

- Need three large bags (fifty pounds each) of crushed ice each day with large ice chest to store ice. In Summer and in hot weather, numbers may increase
- 3 cases of bottled water (suggested for a 32 draw)
- 3 cases of bottled sports drinks (suggested for a 32 draw)
- Refrigerator case for all drinks

#### Hygiene:

- Sink with hot and cold running water (and liquid soap) in treatment room
- Availability of anti-bacterial spray for tabletops and surfaces

## X. EXHIBITS

Floors should be cleaned each night after play is finished and periodically during day at clay court tournaments

#### Desk space for physiotherapists in treatment room:

- Desk with 2-3 chairs
- 1 telephone with local access
- High-speed internet access for 2-3 computers

#### Miscellaneous:

- Countertop space for supplies in treatment room
- Lockable cabinet storage space (for supplies)
- Sufficient electrical outlets on each wall
- Electrical strip of outlets for desk area
- 1 TV with live scoring (closed circuit)

#### Tournament Physician Examination Room:

A separate room for the tournament physician would be good to have for player privacy in consultations. The room should be near player treatment room.

- |                    |                   |
|--------------------|-------------------|
| It should contain: | Desk and chair    |
|                    | Examination table |
|                    | Telephone         |
|                    | Internet access   |
|                    | Lockable cabinet  |

## X. EXHIBITS

### EXHIBIT V - Media Facilities Guidelines

#### A. Media working area

- 1) Adequate workspace for all credentialed media
- 2) High speed internet access \*
- 3) Telephone line
- 4) Power supply
- 5) High capacity copier
- 6) Access to a fax machine
- 7) Smoke free
- 8) Lock boxes or lockers that can be used to store valuables
- 9) Security

#### B. Photographer workstation with internet and telephone access

#### C. Separate, sound proof interview room

#### D. Separate media lounge, where appropriate

#### E. Credentials

- 1) All media must be credentialed.
    - i) Proof of identity must be presented prior to receiving credential.
    - ii) Credentials must include photo.
    - iii) Credential must include the provisions set forth in Rule 6.22.
  - 2) Credentials limited to members of the working press only.
    - i) Journalists known to be working for online gambling companies shall not be issued credentials. If found to be working for an online gambling company after issue of the credential, the credential shall be revoked.
    - ii) Persons who are known to work for data resellers shall not be issued credentials. If found to be working for a data reseller after issue of the credential, the credential shall be revoked.
  - 3) Working area, lounge and interview room must be secured with access provided only to properly credentialed media, players (interview room) and other tournament and ATP Staff when in the performance of their duties.
  - 4) Members of the International Tennis Writers Association (ITWA) shall be given preferred status for workspace and courtside seating as well as access to the players lounge.
    - i) Access to the player's lounge is granted only to those ITWA members who have successfully applied for and have received the ATP World Tour Identification Card.
- \* Unless reasonably unable to do so, tournaments shall use web filtering technology to restrict access to internet gambling sites in all areas where tournament provided internet access is provided, including all areas in the media room.

## X. EXHIBITS

### EXHIBIT W - Electronic Line Calling Facilities Guidelines

A. The ELC booth must be located in direct line of sight to the court, in order to provide an unobstructed view of the court. It should preferably be at the back (North or South end) of the court when possible.

B. The Review Official must have a full view of the whole court and line umpires.

C. The booth must have direct audio from the Chair Umpire's microphone (not from the Television feed).

D. The Review Official should be able to hear the line umpire calls from the court.

E. The booth must have room for five (5) persons plus equipment (minimum of 25 sq. meters (82 sq. feet) with a minimum court frontage of 5 meters (16.5 feet) as required by ELC vendor.

1) 1 person running the system.

2) 1 person dedicated to the Official Review process.

3) 1 person dedicated to the television send.

4) 1 additional staff of the vendor.

5) 1 Review Official for each match - designated by the ATP.

F. The booth should have full air conditioning for equipment and personnel, unless technically unable to do so, and approved by the ATP/WTA and the vendor.

G. Access to the booth must be reasonably easy and safe.

H. Tables, chairs and high stools must be provided as requested by the ELC team.

## X. EXHIBITS

### EXHIBIT X - ELC Review Official Protocol

Shall be designated by the governing body responsible for that match.

Prior to the start of the ELC system on any court, during the CU meeting, be responsible to inform the Chair Umpires about:

On site booth set up

Location

Conditions

Type of communication with ELC Staff and TV

Shall be in direct communication with the Chair Umpire

Most desirable method is a direct talk box with a “push to talk” button.

Alternative is dedicated walkie-talkie.

Prior to the start of every match, ensure the following checks have been completed:

Test communication devices with the chair umpire and board operator.

Confirm with the VR and System Operators that they have completed their respective pre-match checklists.

Confirm specifically with the VR Operator that:

The system is set for the appropriate event (singles or doubles)

During warm-up, view at least one (1) test review

At 1 min. announcement, confirm with the System Operator and the VR Operator that all systems are go.

If using computer to record the challenges load proper match into it.

On all “potential” review impacts – see Review Official Protocol for a Challengeable shot

Alert technicians to a possible review.

Confirm that a review has been requested, or

Anticipate that there will be no review.

“Release to television” announcement establishes the time when television may be sent the video.

This applies to when either the Review Official determines that a Challenge will not be made or cannot be made.

A visual indication that the player has accepted the call and a challenge is not likely.

Circumstances when a challenge cannot be made would include an improper challenge (not a point-ending shot) or when the player has no challenges remaining.

Responsible for determining that the requested impact is available for review.

Once proper impact is determined, gives the order to send to video board and television simultaneously.

Responsible for monitoring the status of the system.

If the system crashes or is not functioning, the review official must immediately notify the chair umpire so that the players may be informed that no review is available until further notice.

If the Review Official's monitor cannot retrieve the data to review the call, then he shall notify the Chair Umpire that the original call shall stand.

## X. EXHIBITS

If the Review Official's monitor is working properly but it is the Main Video Board (in-stadium video) that is malfunctioning, then the Review Official will notify the chair umpire of the decision via radio or other communication device. The Chair Umpire should inform the players of this at the first opportunity.

Will notify the Chair Umpire when the system is back and available for review (if the Review Official is satisfied that the cause has been identified and corrected.)

The review official shall notify the chair umpire at the first available time, including during a game in progress.

Before returning to “live” mode:

Ensure that the operators have performed all of their protocols when returning a system to “go” status following a crash or restart of the system.

Make sure that a test review has been completed in the booth on the VR monitor to ensure that all systems are in working order.

Check with technicians that system has been set-up for the proper event, singles or doubles.

During doubles matches the Review Official should alert the system operator when the score reaches “deuce” so that he may activate the proper service box for the “deciding point”.

Act as the final authority on the number of challenges remaining for each player or team.

Since available challenges will be displayed on the video board, be responsible for communicating with the operator of the display when there is a change in status of available challenges (including the additional challenges in a tie-break). If the video board operator is changing on cue from the chair umpire, then only verification is needed.

If a challenged call is not available for review – this shall not count against the total of the challenging player.

Shall not speak to the press or any media without the permission of the Supervisor.

Ensure that the review official and chair umpire communicate verbally when one player or team has only 1 challenge remaining.

### Video Board

During the warm-up, the following statement shall appear on the video board and remain visible for at least 90 seconds. This should coincide with the Announcer's introductions (if an announcer is used).

“This match will use Electronic Review as an officiating aid. Each player (team) will have three **incorrect** challenges per set, plus one more in a tie-break. Challenges must be made in a timely manner and can only be made on point-ending shots or when a player stops play. If, for any reason, Electronic Review of the call is unavailable, the original call will stand.”

There shall not be any review shown in the Stadium except for “Official Review” challenges. Live action is OK as long as it is of a non-controversial nature.

The in-stadium video shall not replay “live” action on any controversial or reviewed call.

If video replays are shown between points or if the video goes live between

## X. EXHIBITS

points, the operator shall return to the scoreboard just prior to the serving player taking his position at the baseline.

Once it is confirmed that a challenge has been made --

The Review Official shall have direct communication with the operator of the video board and will give verbal instructions on when to show review.

When the Review Official has confirmed the impact image is correct then he gives the order to send result to board.

Video shows the tracking of the ball into and out of the impact area, and then the view angle is moved to show the impact mark. The "flyover" mode is used to slow the process down "to build the moment".

Graphic includes "Official Review".

Graphic at bottom of screen shows "IN" or "OUT".

The "in" / "out" will not appear until after the overhead zoom so as to enhance the drama of the video.

Television will receive the exact same feed as the video board with the graphic "OFFICIAL REVIEW" and showing "IN" OR "OUT".

If review is not available, the Review Official shall notify the chair umpire and then while the chair umpire is informing the players, the graphic "Review Not Available - Original Call Stands" shall be sent to the video board. Reviews not available shall not count against the challenging players total.

The graphic is held until the players have reached the baselines preparing to play, at which time the board returns to the main scoreboard view.

The video board(s), scoreboard(s) or other location(s) must show number of remaining challenges for each player at all times. This information must be part of the scoreboard build.

### Announcing

#### Chair Umpire

When a Challenge is made:

The Player shall clearly express his/her desire to have the call reviewed by stating, "I challenge". If the chair is not 100% sure that the Player is challenging, then the Chair shall confirm with the Player prior to announcing the review request. When the Chair is satisfied that a proper Challenge request has been made, then ----

Chair shall announce over the microphone "Mr \_\_\_\_\_ is challenging the call on the Base Line (give specific line) the ball was called IN/OUT."

After the review, announce, "The calls stands or the call is overturned. Then announce the score if point awarded or replay the point and then repeat the previous score. Depending on the timing, try to also announce "Mr X has X Challenges remaining" when there is a reduction.

If the review is not available, simply say (after informing the players) "Review is unavailable; the original call of IN/OUT stands. No challenge is charged to Mr. \_\_\_\_\_."

In the case where the line umpire is unsighted and the chair umpire cannot make the call, if the umpire asks for a review then he shall inform the crowd of this procedure by stating, "line umpire was unsighted – the call shall be reviewed".

Announce the additional challenges available at the start of each tiebreak.

## X. EXHIBITS

After announcing 6-games all – tie-break, announce "Both players/teams receive one additional challenge."

If there are no in-Stadium Video Boards or if there is a malfunction and they are not available for use, then the chair shall use the following procedures:

The Review Official will communicate the result of the challenge to the Chair Umpire via the radio, using the following wording: "Call challenged by [name of player] on the [name of line]: the ball is IN/OUT".

The chair umpire will acknowledge the good reception of the information by immediately answering the review official using the following wording: "The result of the challenged call on the [name of line] is IN/OUT".

If the review is not available, simply say (after informing the players) "Review is unavailable; the call (in/out) stands".

In the event the video screen shows the mark OUT and the "IN/OUT" text graphic shows IN or the video screen shows the mark IN and the "IN/OUT" text graphic shows OUT, the protocol is as follows:

- 1) The mark determines IN / OUT not the text graphic.
- 2) The chair umpire should communicate with the Review Official to ensure that is correct.
- 3) The corrected text graphic should be displayed on the big screen so players, officials and spectators see the corrected mistake.

The Review Official is prohibited from using the internet while matches are in progress.

The Review Official is prohibited from using e-mail or text in any form while matches are in progress.

## X. EXHIBITS

- Review Official Protocol for a Challengeable Shot

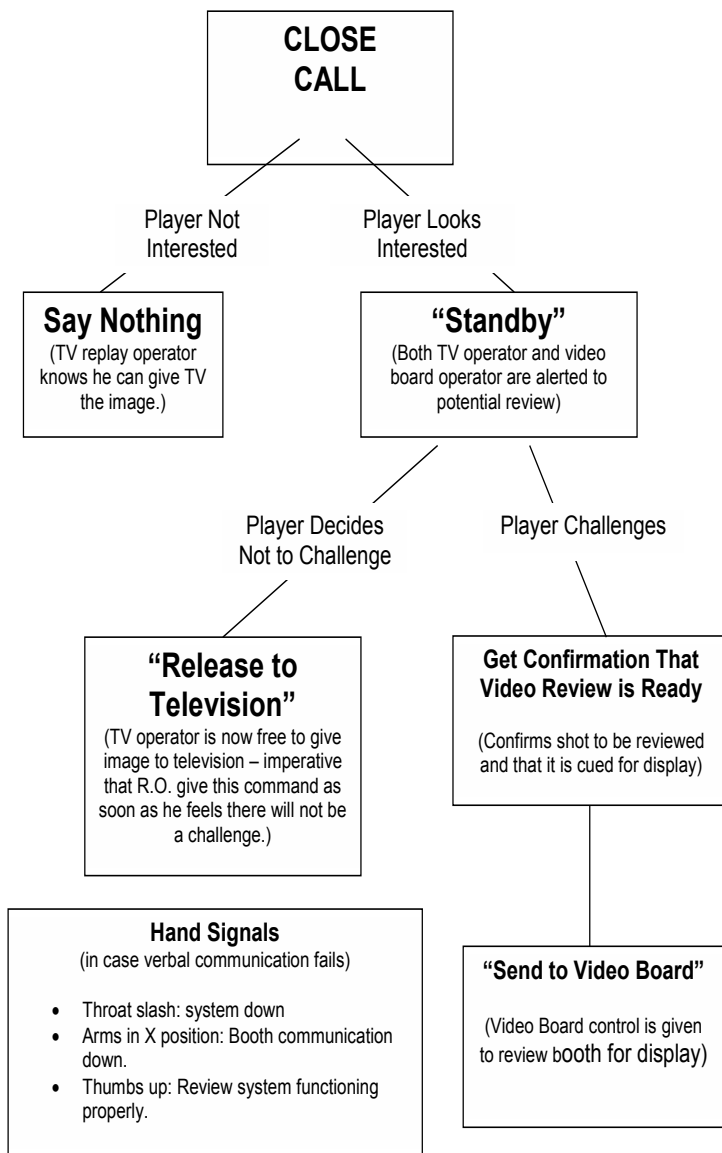

## X. EXHIBITS

### EXHIBIT Y – ATP World Tour 500 Field Expectation

**Category Designation.** ATP World Tour 500 tournaments will be divided into two (2) categories depending on their calendar position and expected field strength (“Capo-Fist”). The two (2) categories are: Doubles and Globals.

**Doubles:** Rotterdam, Dubai and Barcelona.

**Globals:** Memphis, Acapulco, Hamburg, Washington, Beijing, Tokyo, Basel and Valencia.

**Escrow Account.** The Board shall select tournaments\*, based upon Capo-Fist criteria, to make a further financial contribution to a tournament escrow account. The escrow account contribution currency shall be the same currency used to pay that event’s prize money.

Doubles	\$200,000 or	€180,000
Globals (if selected)	\$100,000 or	€90,000

\*Monte Carlo is not included in the escrow account contribution or distribution program.

**Premier Player Group.** Players ranked as a year-end (December 7, 2009) top 30 player (commitment players) are eligible to be selected in the premier player group for purposes of fulfilling the field expectation. The size of the premier player group shall be twelve (12) players plus two (2) alternates selected as follows:

Twelve (12) players and two (2) alternates selected as “regional” premier players by each of the three (3) regions (Americas, European and International). The regional CEO’s shall solicit input from their respective events to determine the twelve (12) regional selections, plus alternates. These twelve (12) players and the two (2) alternates shall be presented to the Board at the final Board meeting of the previous year for approval.

The players identified in each group will be further divided into two groups of six (6) based upon marquee value as determined by the regional CEO and presented to the Board for final approval. These two (2) groups shall be identified as A+ and A. Each region shall also identify two (2) A players as A1 and A2, in addition, the two \*(2) alternates shall be designated as Alternate 1 and Alternate 2.

In the event that an A+ player becomes injured or otherwise is not able to compete for an extended period of time, as determined by the ATP, he will be replaced by the A1 player designated by the region. The A1 player’s position will be filled by alternate 1 as designated by the region

The same procedure will be followed in the event that a second player needs to be replaced as determined by the ATP.

If the replaced player returns to competition during the season, he shall be reinstated as a premier A+ or A player upon the start of his first match (singles or doubles) in his first ATP World Tour 500 event.



## X. EXHIBITS

**Field Expectation.** The tournament player field expectation shall be as follows:

Doubles	2 A+	and	3 A
Globals	2 A+	and	2 A

**Rebate from Escrow.** Tournaments who do not attract a player field that meets the field expectation designated for their category will receive a payment\* from the escrow account as follows:

For each A+ player short of expectation \$150,000 or €135,000

For each A player short of expectation \$100,000 or €90,000

Total payment to any individual tournament cannot exceed \$300,000 or €270,000

\*Payment currency shall be the same currency used to pay that event's prize money.

**Over delivery.** A+ players over the minimum shall result in a credit against any deficiency in overall delivery of player field expectation. For example: if a Double has 3 A+ players and 0 A players, the net amount owed would be \$50,000 or €45,000 (\$100,000 / €90,000 owed for each A player below expectation equals \$200,000 / €180,000 minus \$150,000/€135,000 credit for the additional A+ player).

**Escrow shortfall.** The ATP will make up any deficiency in the escrow account. Distribution of excess monies from the escrow account is determined at the sole discretion of the Board.

**Field Determination.** The field expectation determination time for each premier player shall be the start of his first match of the tournament (singles or doubles).

## X. EXHIBITS

### EXHIBIT Z - Anti-Doping Testing Facilities Guidelines

#### Doping Control Station

The Doping Control Station must be a dedicated facility for the exclusive use of the Doping Control team for the duration of the event.

**Location:** near the locker room (but not with direct access).

**Accommodation:** a minimum of two (and preferably three) connected areas or rooms: a Sample Collection Room and a Waiting Room at a minimum, plus an Administration Room if possible, all of which should be air-conditioned or well ventilated. The Sample Collection Room should be directly connected to a toilet (for the sole use of Doping Control).

**Security:** If free-standing, a security guard should be posted to restrict admission to those with appropriate credentials. It must be lockable, with access restricted to the Doping Control team. The Doping Control Officer must be given charge of all keys to all rooms for the duration of testing.

**Hygiene:** The Doping Control Station should be cleaned every day at a time agreed with the Doping Control Officer.

Items to be supplied in the Doping Control Station (for all draw sizes):

SAMPLE COLLECTION ROOM	WAITING ROOM
1 toilet	Comfortable seating for 8 people
Desk and 4 chairs	Refrigerator with an adequate supply of individually sealed, non-caffeniated and non-alcoholic beverages
Table to display testing materials	Table to display reading materials
TV/Court Monitor (and also in the Administration Room if provided)	TV/Court Monitor
Mains electricity supply	Waste bin
Lockable refrigerator	
2 large waste bins	
Sink, with soap or hand wash	
paper towels	
Storage cupboard	

## X. EXHIBITS

A suggested layout for a doping control station is shown in the diagram below:

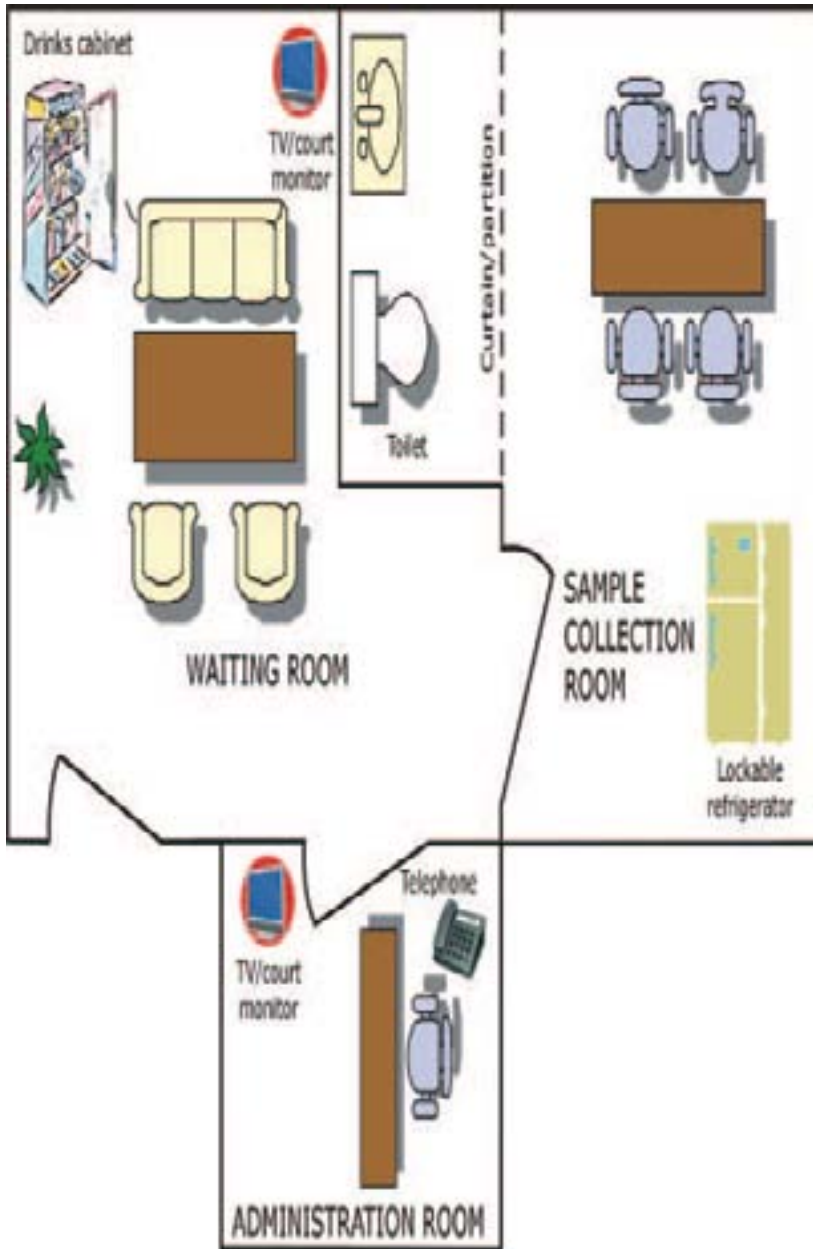

## X. EXHIBITS

### EXHIBIT AA - Retractable Roof Policy

Whenever practical, playing conditions on the center court will remain the same as on all other courts.

In the event rain is falling prior to the scheduled starting time of the match, the roof will remain closed for the duration of that match.

If the rain stops and the forecast is good, the roof may be opened after the match in progress is completed. Decisions on re-opening the roof will be made on a match-by-match basis depending upon current conditions and the forecast.

If play commences with the roof open, a decision to close the roof will normally be made after play has stopped because of rain, although if other factors warrant the roof to be closed prior to this, the Supervisor will make that decision.

The roof will not normally be closed because of the threat of rain.

In the event high winds, sufficient to harm the retractable roof, are forecast with reasonable certainty, the roof may be closed prior to the start of the match. The reverse is applicable when the roof is closed and high winds or other conditions necessitate, for safety reasons, that the roof be opened.

In the event that the temperature is below 50F / 10C prior to the start of a match, in order to enhance the fan experience, the roof may be closed as directed by the supervisor. Decisions on whether to close the roof for cold will be made on a match-by-match basis.

In some instances, the roof must be partially closed for the lights to function properly. In this case, the roof must be partially closed prior to the start of the match.

The ATP supervisor shall be the final authority on all decisions regarding the opening and/or closing of the roof.

In the event that the temperature is below 50F / 10C prior to the start of a match, in order to enhance the fan experience, the roof may be closed as directed by the Supervisor. Decisions on whether to close the roof for cold will be made on a match-by-match basis.

## X. EXHIBITS

### EXHIBIT AB - ATP Challenger Tour Court Surface ID

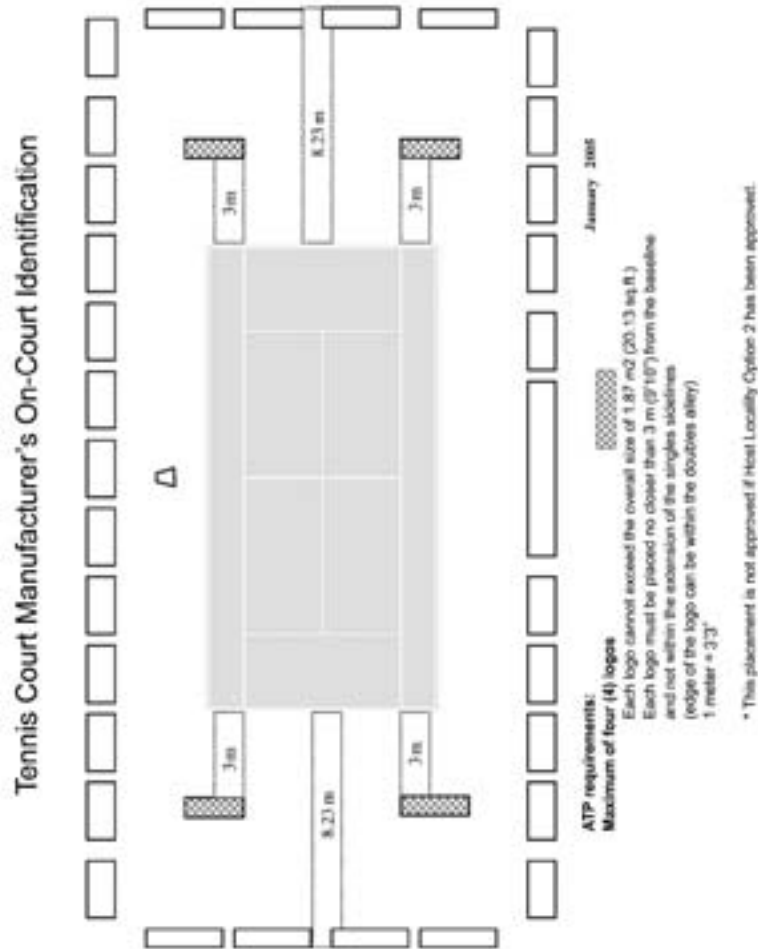

## INDEX

### A

Aggravated Behavior, 171  
Announcing, 140  
Anti-Corruption, 175  
Anti-Doping, 77  
    On-Site Testing Facility, 77  
    Volunteer Observers, 78  
Appeal of Calls, 118  
Appeal of Violations of STARS Program, 170  
Appeals Tribunal, 157  
Application Requirements, 145  
ATP Circuit Regulations, 7  
ATP Patch, 158  
ATP Player Entry and Commitment To Rules, 9  
Attendance Quality Standards, 223  
Audible Obscenity, 163

### B

Back Fences, 68  
Back Walls, 68  
Bags, 158  
Ball Abuse, 162  
Ball Mark Inspection Procedures, 122  
    Chair Umpire, 122  
    Line Umpires, 122  
Ball Persons  
    Clothing, 63  
    Number, 63  
Balls, 69  
    ATP Challenger Tour, 69  
    ATP World Tour Tournaments, 69  
    Changes and Number, 69  
    Lost Balls, 69  
        ATP Challenger Tour, 69  
        ATP World Tour Tournaments, 69  
Practice Balls, 69  
    ATP/Challenger Qualifying Competition:, 70  
    ATP Challenger Tour, 69  
    ATP World Tour Tournaments, 69  
Banners, 68  
Barclays ATP World Tour Finals - Doubles, 42  
    Competition Format, 42  
    Entries, 42  
        Alternates (s), 42  
        Direct Acceptances, 42

## INDEX

- Selection Lost, 42
- Withdrawal, 42
- Order of Play, 43
  - Round Robin, 43
- Prize Money and Points, 45
- Singles Elimination Competition, 45
- Barclays ATP World Tour Finals - Singles, 39
  - Competition Format, 39
  - Entries, 39
    - Alternate(s), 39
    - Direct Acceptances, 39
    - Selection List, 39
    - Withdrawal, 39
  - Order of Play, 40
    - Round Robin, 40
  - Prize Money and Points, 42
  - Single Elimination Competition, 42
- Best Efforts, 164
- Beverages, 73
  - Officials, 73
  - Players, 73
- Bonus pool, 11
- Branding, 21
- Broadcast Quality Standards, 219
- Byes - Assignment and Placement, 104

## C

- Calling of Matches, 113
- Cases & Decisions
  - Alternate Sign-In Procedures, 106
- Balls
  - Ball Change Error, 70
  - Broken Ball, 70
  - New Balls to Wrong Player(s), 70
  - Re-Warm-Up, Balls, 70
  - Soft Ball, 70
- Clay Court Cases, 122
  - Can't Find Ball Mark, 122
  - Doubles Ball Mark Appeal, 122
  - Must Both Players on a Team Stop, 123
  - Overrule Then Inspect Ball Mark, 123
- Correcting an Error in Seeding, 91
- Correct When Left Out of Draw, 91
- Default - List Penalties, 166
- Don't Have Eight Seeds, 91
- Eligible for Lucky Loser, 106

## INDEX

- Extending Closing Times, 107
- Hindrance Cases, 120
  - Corrected Call, 120
  - Early Foot Fault Call, 121
  - Inadvertent Hindrance, 120
  - Opponent Makes Noise, 120
  - Opponent's Gear Falls On The Court, 120
  - Singles Stick Falls, 120
  - Spectator Noise, 121
- I'm In the Main Draw, 91
- Late Transportation, 166
- Main Draw Seed for a Qualifier, 92
- Main Draw Vacancy Before Qualifying Starts, 109
- May I Accept a Challenger Wild Card after losing in an ATP Qualifying, 98
- May I Accept a Wild Card after Withdrawing from an ATP World Tour 500 Qualifying, 98
- May I Play Grand Slam Qualifying After Losing in an ATP World Tour tournament?, 98
- Medical Cases, 132
  - Chair Umpire Orders Medical Time-Out, 134
  - Delayed Medical Time-Out, 132
  - Equipment Out of Adjustment (Knee Brace), 132
  - Exceeding 90 Seconds: Code Violation, 132
  - Medical Time-Out and Re-Warm-Up, 132
  - Medical Time-Out Request Honored?, 132
  - Medical Time-Out Starts When?, 133
  - Only 90 Seconds to Re-Tape, 133
  - Penalties After Medical Time-Out, 133
  - Re-Injury, 133
  - Resuming Play After a Medical Time-Out, 133
  - Singles Retirement: Still in Doubles?, 134
  - Tape Is Not "Equipment Adjustment", 134
  - Treatment for Fatigue, 134
  - Treatment: Within 90 Seconds, 134
  - When to Take a Medical Time-Out?, 134
- Miscellaneous Officiating Cases, 135
  - Ball Hits Net Post Signage, 135
  - Ball Rolls Onto Court, 136
  - Ball Touches Net Pipe Support, 136
  - Broken String: First Service Fault, 135
  - Broken String: First Service Let, 135
  - Broken String: No Racquets, 135
  - Intimidating Line Umpire, 137
  - Invasion: Ball in Play, 135
  - Invasion: No Replay, 135

## INDEX

- Player Hits Net Pipe Support, 136
- Player Touches Net Outside of Singles Stick, 136
- Receiver Not Ready, 135
- Service Order, 137
- Touching Net or Opponent's Court, 136
- Moving Indoors at an Outdoor event, 117
- No Medical? Big Mistake, 151
- No Penalty After Retirement, 155
- Partner Injured: Who May Replace Him?, 108
- Player Entitled to Minimum Rest, 116
- Player Pulled from ATP World Tour 500 Qualifying, 92
- Players Don't Call Lines, 138
- Potential Special Exempt Loses: After 9 p.m., 94
- Potential Special Exempt Playing at 9 p.m. Friday, 94
- Protected Ranking is for Entry, Not Seeding, 101
- Punctuality, 166
- Rain Delayed Semifinal, When to Play Final?, 117
- Rain: How Many Matches Per Player?, 116
- Remake of Draw, 104
- Scheduling Priorities, 117
- Seeds Withdraw or Are Withdrawn, 110
- Special Exempt Awarded if Player Is in Semis?, 95
- Tattoo as Logo, 160
- Tennis Law - Cases, 118
  - Appealing for a Let, 119
  - Appeal of Judgment Calls, 118
  - Appeal of the "Facts": Receiver, 118
  - Appeal of the "Facts": Server, 119
  - Umpire Blocked on Question of Fact, 119
- Time and Equipment Cases, 126
  - Ball Person as Personal Valet, 126
  - Changing Shoes, 127
  - Contact Lens, 127
  - Crowd Movement, 126
  - No Play After 90 Seconds, 128
  - Re-Gripping Racquet, 127
  - Replacing Shoes, 127
  - Shoe Breaks, 128
  - Time: Refusal to Play, 127
  - Time Violation + 25 Seconds = Code, 126
  - Time Violation, No Play, Results in Code, 126
  - Two Explanations are Enough, 126
- Toilet Visit, 128
- Toilet Visit: When Does Play Resume?, 128
- Two Chances, 97
- Unused Wild Cards, 97

## INDEX

- Use of Both Rankings, 100
- What Size Draw, 90
- Which Lucky Loser to Insert?, 107
- Who Goes In, 107
- Who to Seed in singles Qualifying, 92
- Wild Card After ATP World Tour 500 Qualifying Withdrawal, 97
- Wild Card Pulled from Qualifying, 97
- Categories of Tournaments, 7
- Ceiling Height, 68
- Ceremonies, 164
- Chairs, 71
  - Chair Umpire, 71
  - Line Umpire, 72
  - Net Judge, 72
  - Player, 72
- Chair Umpire, 56
  - Assignment and Designation Process, 56
  - ATP Challenger Tour Tournaments
    - Chair Umpires, 56
    - Supplemental Chair Umpires, 56
  - ATP World Tour Tournaments, 56
  - Fees and Expenses, 57
  - General, 57
  - Responsibilities, 57
- Challenges, number of, 123, 251
- Change of Tournament Site, 9
- Chief of Umpires, 283
  - Assignment and Designation Process, 62
  - Fees and Expenses, 62
  - General, 63
  - Responsibilities, 63
- Clear Mistake, 121
- Clothing Designs, 158
- Clothing Sponsor., 158
- Clothing Sponsor Logo, 158
- Coaches, 164
- Coaching, 164
- Code of Conduct, 148
- Code Violations Not Witnessed By Chair Umpire, 162
- Commercial Identification, 158
- Commitment, 10
- Commitment and Membership Obligations, 10
- Commitment to Rules, 10
- Communication Devices, 73
- Composition of Commitment, 31
- Conduct Contrary to the Integrity of the Game, 145
- Consent Form, 287
- Continuous Play, 124

## INDEX

- Copy machine, 73
- Corrected Call, 119
- Correction/Verification of Call, 121
- Courts, 67
  - Back Fences, Back Walls, Banners, Signs and Seats, 68
  - Ceiling Height, 68
  - Light poles, 68
  - Preparation of Surface, 67
  - Size, Position and Color of Courts, 67
  - Surface, 67
- Court Surface ID, 308
- Crowd Movement, 71
- Cumulative On-Site Offenses, 169
- Currency, 31

## D

- Default, 165
  - Penalties, 165
- Default of Prize Money Payments, 31
- Delay of Game, 124
- Doctor, 54
  - ATP Challenger Tour Tournaments, 54
  - ATP World Tour Tournaments, 54
- Draw, 87
  - Composition of Draws, 88
  - Minimum Draw Size, 87
  - Remake of Doubles, 104
  - Remake of Singles, 104
  - Size and Method, 90
  - Time of Draw, 95
    - Main Draw Doubles, 95
    - Main Draw Singles, 95
    - Qualifying Doubles, 95
    - Qualifying Singles, 95
- Dress and Equipment, 157
- Drink Containers, 158

## E

- Electrolyte, 73
  - Drink Container, 158
  - Officials, 73
  - Players, 73
  - Referee Responsibilities, 62
- Electronic devices, 165
- Electronic Insertion, 16, 224
- Electronic Review, 123

## INDEX

- Entry Fees, 79
- Entry Obligations, 148
- Entry Protection, 189
- Entry Selection, 97
  - Direct Acceptances, 97
  - Doubles, 100
  - Qualifiers, 97
  - Special Exempts, 98
  - Wild Cards, 98
- Entry/Withdrawal Method, 82
- Entry/Withdrawal Offenses, 148
- Equipment Abuse, 162
- Equipment & Supplies, 71
  - Placement/Approval, 71
- Exchange Rate Adjustment Rule, 34
- Exhibition Release, 86
- Exhibitions, 15
  - Promotional Fees, 16
  - Restrictions, 15

## F

- Facilities and On-Site Conditions, 67
- Failure to Complete Match, 164
- Fee Obligation, 31
  - ATP Challenger Tour Tournaments, 31
  - ATP World Tour Tournaments, 31
  - Late Payments, 32
- Fees/Other Payments, 32
- Field Expectation, 303
- Final Dispute Resolution, 185
- Financial, 31
- Fines and Penalties, 148
- First Aid, 77
- Food, 76

## G

- Glossary, 279
- Good Standing, 10

## H

- Hat, 159
- Headband, 159
- Hindrance, 119
- Hospitality, 17
- Host Broadcaster, 219
- Host Locality, 212

## INDEX

Court Host Locality, 213  
Hotel Accommodations (Rooms), 17  
Other Reservations., 20

### I

Identification/Visible, 158  
Inadvertent Hindrance, 120  
Indoor Facilities, 73  
Insurance, 32

### J

Jacket, 159

### L

Laptop Restrictions, 71  
Late Payment, 35  
Leaving the Court, 164  
Letter of Credit, 32  
    New/Conditional Tournaments, 32  
Lighting, 67  
Limits to On-Site Access, 75  
Line Umpire, 59  
    Assignment and Designation Process  
    , 59  
    ATP Challenger Tour Tournaments, 59  
    ATP World Tour Tournaments, 59  
    Clothing, 60  
    General, 59  
    Responsibilities, 60  
Line Umpire Requirement, 137  
    Five (5) Line Umpires, 138  
    Four (4) Line Umpires, 138  
    Full Complement, 137  
    Hand Signals, 138  
    Less than a Full Complement, 137  
    Less Than Four (4) Line Umpires, 138  
    Number for Matches, 137  
    Seven (7) Line Umpires, 137  
    Six (6) Line Umpires, 137  
    Umpiring Without Line Umpires, 138  
Live Scoring, 74  
Locker Room, 76  
Logo Usage, 158  
Lucky Losers, 105  
    Selection, 105  
    Substitution, 105

## INDEX

### M

Main Draw, 7  
Mandatory Player Meeting, 13  
Massage Therapist, 54  
    ATP Challenger Tour Tournaments, 54  
    ATP World Tour Tournaments, 54  
Match Schedule Plan, 8  
Measuring Devices, 72  
Media Conference, 167  
Media Highlight Rights, 16  
Medical, 128  
    Bleeding, 130  
    Cases & Decisions, 132  
    Evaluation, 128  
    Penalty, 130  
    Physical Incapacity, 131  
    Time-Out, 129  
    Vomiting, 131  
Monday Finals, 7

### N

Net, 24, 28, 72  
    Net Judge, 72  
    Net Posts, 72  
    Net Posts and Net Post Signage, 72  
New/Conditional Tournaments, 32  
No Show, 280

### O

Offenses, 162  
Offices, 73  
On-Court Procedures, 117  
On-Court Requirements, 117  
One Tournament Per Week, 86  
On-Site Access, 75  
On-Site Conditions, 67  
On-Site Offenses, 157  
On-Site Prize Money Adjustment, 34  
On-Site Prize Money Minimums, 34  
On-Site Procedures, 157  
Order of Play, 113  
    Change, 113  
    Notes / Reminders, 113  
    Notification, 113  
    Release Deadline, 113  
Other Circuit, 145

## INDEX

Overrule, 121

## P

Payment, 35

Payment of Fines, 152, 170

ATP World Tour and ATP Challenger Tour Tournaments, 170

ATP World Tour Team Championship, 170

Procedures for Appeal, 170

Personnel, 53

Phones, 73

Physical Abuse, 163

Physical Exam, 13

Physiotherapist, 54

ATP Challenger Tour Tournaments, 54

ATP World Tour Tournaments, 54

Player Eligibility, 13

Player Entry and Commitment To Rules, 9

Player Introductions, 142

Player Lounge, 75

Player Major Offenses, 171

Player Obligations, 20

Player Passes/Credentials, 75

Player Publicity and Promotion, 14

Player Rights, 118

Player Treatment Room, 77

Player University, 13

Playing Another event, 152

Play-Up Regulation

Restrictions, 86

Point Penalty Schedule, 162

Practice Courts, 68

Privacy Notice ("HIPPA"), 289

Prize Money, 33

General, 33

Prize Money / Fee Payments, 34

ATP Challenger Tour Tournaments, 34

ATP World Tour Tournaments, 34

Prizes and Non-Cash Awards, 36

PR & Marketing, 53

Prohibited Promotional Fees, 172

Promotional Activities, 153, 154

Promotional Fees, 145

## Q

Qualifier Reservations, 20

Qualifying, 7

Doubles, 8

## INDEX

Seed Placement, 103

Sign-in Location, 83

Singles, 7

Entry Deadline, 80

General, 7

Location., 8

Surface, 8

Time, 80

Qualifying Non-Appearance, 152

Quality/Broadcast, 16

Questions of Fact, 118

Questions of Tennis Law, 118

## R

Racquet, 159

Racquet Abuse, 162

Rain, 114

Rankings, 187

Definitions, 187

Eligibility, 187

Reasonable pace of the server, 167

Rebate, 304

Referee, 61

Assignment and Designation Process, 61

ATP Challenger Tour Tournaments, 61

ATP World Tour Tournaments, 61

Fees and Expenses, 61

General, 61

Responsibilities, 62

Waiver of Obligation, 61

Release from Financial Commitment, 36

Repeal of Withdrawal Fines and/or Penalties, 152

Rest Periods - Minimums and Guidelines, 114

Between Main Draw and Prior Week's Tournament(s), 114

Between Main Draw and Qualifying, 114

Between Main Draw Matches, 115

Between Semi-final and Final, 116

Restrictions, 160

General, 160

Government, 160

Other Tennis event, 160

Timing, 160

Tobacco, 160

Tournament Sponsor Conflict, 160

Retirement or Withdrawal Penalty (On-Site), 151

Retiring from the Professional Tennis Circuit, 195

Review of Penalties, 156



## INDEX

Re-warm up, 125  
Rules of Tennis, 118, 227

## S

Sawdust, 69  
Scheduling Committee, 111  
Scheduling of Matches, 111  
    Daily Overview, 112  
    Main Draw, 111  
        Considerations and Priorities, 111  
    Qualifying, 111  
    Tournament Week Plan, 111  
    Wednesday starts, 114  
Scoreboards, 72  
Scoring of Match, 139  
Seating and Attendance, 17  
Seats, 68  
Security at Tournaments, 71  
Seeds, 100  
    Definition, 101  
    Doubles, 100  
    Number, 102  
    Placement, 102  
        Qualifying, 103  
    Replacement, 99, 109  
Shirt, 159  
Shoes, 160  
    Clay Courts, 161  
    General, 160  
    Grass Courts, 161  
Shorts, 159  
Signs, 68  
Singles Finals Options, 8  
Sleeveless, 159  
Sleeves, 159  
Socks, 160  
Special Events - Exhibitions, 15  
Special Exempt Non Appearance, 94  
Special Exempts, 92, 281  
    Eligibility, 92  
    Non-Appearance, 281  
    Number, 93  
    Process, 93  
    Selection, 93  
Spectator seating, 68  
STARS Program, 14  
    Penalties, 168

## INDEX

Responsibilities, 14  
Start of Match, 117  
Start of Tournament, 117  
Stoppage and Postponement of a Match, 125  
Substitutions, 105  
Supervisor  
    Assignment & Designation, 54  
    ATP Challenger Tour Tournaments, 54  
    ATP World Tour Tournaments, 54  
    Fees and Expenses, 54  
    General, 55  
    Responsibilities, 55  
Suspensions and Collection of Fines, 174  
    Stay of Suspensions Pending Appeal, 174  
    Suspension for Non-Payment of Fines, 174  
    Suspension - Weeks/Scope, 174  
Sweater, 159

## T

Tape Delay/Repeats, 219  
Taxes, 35  
    Notice of Withholdings, 35  
    Withholding From Prize Money, 36  
Temperature, 73  
Tennis Equipment Manufacturer, 158  
The Code, 145  
The Competition, 79  
Toilet Break, 128  
Tour Identification Card, 74  
Tour Manager, 53  
    Appointment, 53  
    Responsibilities, 53  
Tournament Credentialing, 74  
Tournament Director, 53  
    Appointment, 53  
    Responsibilities, 53  
Tournament Financial Information, 36  
Tournament Obligations, 17, 145  
    ATP Challenger Tour Tournaments, 19  
    ATP World Tour Tournaments, 17  
Tournament Report, 146  
Tournament Violations, 146  
    Determination, 147  
    Imposition, 147  
    Investigation, 147  
    Review, 147  
Tournament Week, 7

## INDEX

Towels, 72, 158, 294  
Transportation, 77  
Treatment Room, 77

## U

Unsatisfied Player Commitment Penalties, 12  
    Failure To Participate in the Barclays ATP World Tour Finals, 12  
    Review of Penalties for Breach of Commitment, 12  
Unsportsmanlike Conduct, 163

## V

Vacancies, 105  
    Other Vacancy Procedures, 110  
    Prior to Qualifying Competition, 108  
    Qualifying started or finished, 109  
Ventilation, 73  
Verbal Abuse, 163  
Verification of Call, 121  
Violations/Fines, 161  
    ATP Patch, 161  
    Clothing Sponsor, 161  
    Commercial Identification, 161  
    Doubles Team Attire, 161  
    Other Tennis event, 161  
    Tennis Equipment Manufacturer's logo, 161  
    Unacceptable Attire, 161

## W

Wagers, 146  
Waiver of Claims, 13  
Warm up, 125  
Web Filtering, 74  
    Internet, 73  
    Media Facilities, 78  
    Player Lounge, 75  
Wednesday starts, 114  
Wild Card Non-Appearance, 152  
Wild Cards, 95  
    Limitation, 96  
    Regulations, 95  
    Restrictions  
        Doubles, 96  
        Singles, 95  
Withdrawals, 82  
    Emergency Situations, 81  
    Method, 82

## INDEX

No Play After Withdrawal, 85  
On-Site, 151  
Penalties, 84, 151  
World Championships, 39  
World Team Championship, 45  
    Prize Money, 47  
        Breakdown, 47  
        Team Prize Money Distribution, 47  
    Travel, 48  
    Schedule of Play, 48  
Wristband, 159