

**STOCK ASSESSMENT OF ALBACORE TUNA IN THE NORTH
PACIFIC OCEAN IN 2014**

REPORT OF THE ALBACORE WORKING GROUP

**International Scientific Committee for Tuna and Tuna-like Species in
the North Pacific Ocean**

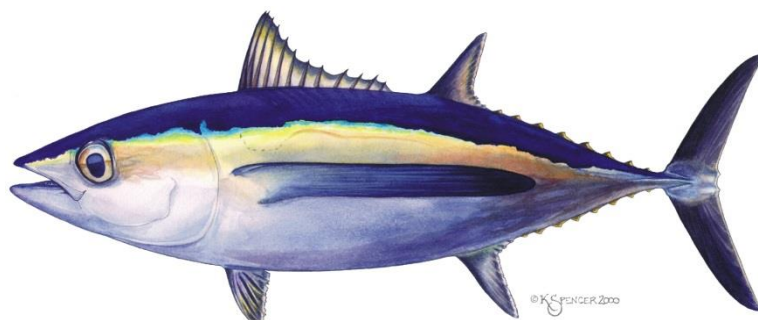

**16 - 21 July 2014
Taipei, Taiwan**

Page Intentionally Blank for Printing

TABLE OF CONTENTS

TABLE OF CONTENTS	2
ACKNOWLEDGEMENTS	5
EXECUTIVE SUMMARY	6
1.0 INTRODUCTION	18
2.0 BACKGROUND.....	19
2.1 Biology	19
2.1.1 Stock Structure	19
2.1.2 Reproduction	19
2.1.3 Growth.....	20
2.1.4 Movements.....	20
2.2 Fisheries.....	21
3.0 DATA.....	21
3.1 Spatial Stratification.....	21
3.2 Temporal Stratification.....	22
3.3 Fishery Definitions	22
3.4 Catch and Effort.....	23
3.5 Relative Abundance Indices	23
3.5.1 S1 and S2 – Japan Longline	24
3.5.2 S3 and S4 – Japan Pole-and-Line	24
3.5.3 S5 – Taiwan Albacore-Targeting Longline	24
3.5.4 S6 and S7 – Japan Longline	24
3.5.5 S8, S9, and S10 – EPO Surface Fisheries	25
3.5.6 S11 – USA Deep-set Longline.....	25
3.5.7 Observed Abundance Trends	25
3.5.8 Base case Model Indices.....	26
3.6 Size Composition	26
3.7 Sex Ratio.....	27
4.0 MODEL DESCRIPTION	27
4.1 Stock Synthesis	28
4.2 Biological and Demographic Assumptions.....	28
4.2.1 Maximum Age	28

4.2.2 Growth.....	28
4.2.3 Weight-at-Length	29
4.2.4 Sex Specificity	29
4.2.5 Natural Mortality.....	30
4.2.6 Movement	30
4.2.7 Stock Structure	30
4.2.8 Recruitment and Reproduction.....	30
4.2.9 Initial Conditions	31
4.3 Fishery Dynamics	32
4.3.1 Selectivity.....	32
4.3.2 Catchability	33
4.4 Data Observation Models.....	33
4.5 Data Weighting	34
4.6 Model Diagnostics	34
4.6.1 Model Convergence.....	35
4.6.2 Likelihood Profile on Virgin Recruitment (R_0)	35
4.6.3 Residual Analysis.....	35
4.6.4 Retrospective Analysis.....	35
4.7 Sensitivity to Model Assumptions.....	35
4.8 Fishery Impact Analysis.....	35
4.9 Future Projections.....	36
5.0 STOCK ASSESSMENT MODELLING RESULTS	36
5.1 Model Convergence.....	36
5.2 Model Diagnostics	36
5.2.1 Likelihood Profiles on Virgin Recruitment (R_0).....	36
5.2.2 Residual Analysis of Abundance Indices	37
5.2.3 Residual Analysis of Size Composition Data	38
5.2.4 Retrospective Analysis.....	38
5.3 Model Parameter Estimates	38
5.3.1 Selectivity.....	38
5.3.2 Catchability	39
5.3.3 Catch-at-Age.....	39
5.3.4 Sex Ratio.....	39
5.4 Stock Assessment Results.....	39
5.4.1 Biomass	39

5.4.2 Recruitment	40
5.4.3 Fishing Mortality	40
5.5 Biological Reference Points	40
5.6 Sensitivity to Model Assumptions.....	41
5.6.1 Sensitivity 01 – Growth Hypothesis 1.....	41
5.6.2 Sensitivity 02 – CV of L_{inf}	42
5.6.3 Sensitivity 03 – Non Sex-Specific Growth.....	42
5.6.4 Sensitivity 04 – Stock-Recruitment Steepness Parameter.....	42
5.6.5 Sensitivity 05 – Natural Mortality.....	42
5.6.6 Sensitivity 06 – Alternative Juvenile Abundance Indices.....	42
5.6.7 Sensitivity 07 – CV of Juvenile Abundance Indices.....	43
5.6.8 Sensitivity 08 – Alternative Adult Abundance Indices.....	43
5.6.9 Sensitivity 09 – Start Year	43
5.6.10 Sensitivity 10 – Size Composition Weighting	43
5.7 Fishery Impact Analysis.....	43
5.8 Future Projections.....	44
6.0 STOCK STATUS	44
6.1 Current Status.....	44
6.2 Conservation Advice	45
7.0 KEY UNCERTAINTIES AND RESEARCH RECOMMENDATIONS.....	45
8.0 LITERATURE CITED	47
TABLES	53
FIGURES.....	75
APPENDIX A.....	121
APPENDIX B.....	122

ACKNOWLEDGEMENTS

The 2014 stock assessment of north Pacific albacore tuna is the result of a collaborative effort of Albacore Working Group. Members of the Working Group include John Holmes (Chair), Chiee-Young Chen, Keisuke Satoh, Hirotaka Ijima, Hidetada Kiyofuji, Steve Teo, Kevin Piner, and Carolina Minte-Vera. Steve Teo with assistance from Kevin Piner, Hirotaka Ijima, and Hidetada Kiyofuji were the lead modellers on this assessment. The Working Group is indebted to Ian Stewart (International Pacific Halibut Commission) and Mark Maunder (Inter-American Tropical Tuna Commission) for their insight and feedback on model structure and performance during the assessment modelling process.

EXECUTIVE SUMMARY

Stock Identification and Distribution: The north Pacific albacore tuna (*Thunnus alalunga*) stock area consists of all waters in the Pacific Ocean north of the equator and all available fishery data from this area were used for the stock assessment. It is assumed that there is instantaneous mixing of albacore throughout the stock area on a quarterly basis, i.e., a single well-mixed stock.

Catches: The total reported catch of north Pacific albacore was relatively low in the 1950s and 1960s and increased to a peak of 126,175 metric tonnes (t) in the mid-1970s before declining and reaching a secondary peak by the late 1990s (Figure 1). Following a second decline in the early 2000s, catch has recovered slightly to fluctuate between 69,000 and 92,000 t in recent years (2006-2012). Surface gears (troll, pole-and-line) have accounted for approximately twice as much albacore catch as longline gear since the early 1950s (Figure 2).

Data and Assessment: Catch and size composition data were collected from ISC countries (Canada, Chinese Taipei, Japan, Korea, and USA) and some Inter-American Tropical Tuna Commission (IATTC) and Western and Central Pacific Fisheries Commission (WCPFC) member countries, including China (Table 1). Standardized catch-per-unit-effort data for 11 indices used to measure trends in relative abundance were provided by Japan, USA, Canada, and Chinese Taipei. However, based on a closer examination of these abundance indices, the Albacore Working Group (ALWBG) concluded that the Japan pole-and-line (PL) and longline (LL) indices were the indices most representative of trends in juvenile and adult abundance, respectively, and the base case model was therefore fitted to these indices. The north Pacific albacore tuna stock was assessed using an age-, length-, and sex-structured Stock Synthesis (SS Version 3.24f) model fitted to time series of standardized CPUE and size composition data over a 1966 to 2012 time frame. Sex-specific growth curves were used because there is evidence of sexually dimorphic growth, with adult male albacore attaining a larger size and age than female albacore. The assumed value of the steepness parameter in the Beverton-Holt stock-recruitment relationship was $h = 0.9$, based on two separate external estimates of this parameter. The assessment model was fitted to the abundance indices and size composition data in a likelihood-based statistical framework. Maximum likelihood estimates of model parameters, derived outputs, and their variances were used to characterize stock status. Several sensitivity analyses were conducted to evaluate changes in model performance or the range of uncertainty resulting from changes in model parameters, including some of the data series used in the analyses, growth curve parameters, natural mortality, stock-recruitment steepness, starting year, selectivity estimation, and weighting of size composition data.

Stock Status: Estimates of total stock biomass (age-1 and older) show a long term decline from the early 1970s to 1990 followed by a recovery through the 1990s and subsequent fluctuations without trend in the 2000s (Figure 3). Female spawning biomass (SSB) exhibits similar long-term changes, with a decline from the early 1970s to the early 1990s, a recovery in the late 1990s and a levelling off in the late 2000s. Female SSB was estimated to be approximately 110,101 t in the terminal year of the assessment (2012) and stock depletion is estimated to be 35.8% of unfished SSB. The estimated SPR (spawners per recruit relative to the unfished population) in the terminal year of the assessment is 0.41, which corresponds to a relatively low exploitation level (i.e., $1-SPR = 0.59$). While current F-at-age on juvenile fish is lower in the base case model than in 2002-2004, F on adult ages (50% of age-5 and all fish age-6 and older) is higher on average than 2002-2004 (Figure 4). Juvenile albacore aged 2 and 3 are the largest component of the catch (Figure 5) as reflected by the larger impact of the surface fisheries (primarily troll, pole-and-line, but including several minor gears) relative to longline fisheries which remove adult fish (Figure 6). Average historical recruitment is approximately 42.8×10^6 recruits annually, but there are periods of above and below

average recruitment at the beginning of the assessment time frame followed by fluctuations around the average since the 1990s (Figure 3). The ALBWG believes that north Pacific albacore recruitment, as in other tuna species, is influenced by changes in environmental conditions and the stock-recruitment relationship. Kobe plots depict stock status in relation to MSY-based and MSY proxy reference points (see below) from the base case model (Figure 7). The Kobe plots are presented for illustrative purposes since biological reference points have not been established for the north Pacific albacore stock, with the exception of the $F_{SSB-ATHL}$ interim reference point used by the Northern Committee of the Western and Central Pacific Fisheries Commission (NC-WCPFC). $F_{SSB-ATHL}$ is the fishing mortality that results in future SSB, over a 25 year projection period, falling below the average of the ten lowest estimated SSBs (SSB-ATHL) historically with a 50% probability. Based on an evaluation of the estimated current F ($F_{2010-2012}$) against various F-based reference points, including $F_{SSB-ATHL}$, the north Pacific albacore stock is not currently experiencing overfishing (Table 1) since the ratios for most candidate reference points, except F_{MED} and $F_{50\%}$, are below 1.0. Although no biomass-based reference points have been developed for this stock, there is little evidence from this assessment that fishing has reduced SSB below reasonable candidate biomass-based reference points (Figure 7), so the ALBWG concludes that the stock is likely not in an overfished condition at present.

Table 1. Potential reference points and estimated F-ratios using current F ($F_{2010-2012}$) and $F_{2002-2004}$ (reference years for north Pacific albacore CMMs adopted by the IATTC and WCPFC) to assess current stock status, associated spawning biomass and equilibrium yield for north Pacific albacore when exploited at $F_{2010-2012}$. Median SSB and yield are shown for $F_{SSB-ATHL}$ as this simulation-based reference point is based on a non-equilibrium concept.

Reference Point	$F_{2002-2004}/F_{RP}$	$F_{2010-2012}/F_{RP}$	SSB (t)	Equilibrium Yield (t)
$F_{SSB-ATHL}$	0.85	0.72	100,344	90,256
F_{MSY}	0.76	0.52	49,680	105,571
$F_{0.1}$	0.56	0.51	73,380	93,939
F_{MED}	1.34	1.30	156,291	74,640
$F_{10\%}$	0.71	0.63	22,867	96,590
$F_{20\%}$	0.80	0.71	54,530	105,418
$F_{30\%}$	0.92	0.81	86,192	99,612
$F_{40\%}$	1.07	0.94	117,855	89,568
$F_{50\%}$	1.29	1.13	149,517	77,429

Projections: Stochastic stock projections were conducted externally to the base case model to evaluate the impact of various levels of fishing intensity on future female SSB for north Pacific albacore. Future recruitment was based on random resampling of historical recruitment for three periods: (1) low recruitment (29.1×10^6 recruits), 1983-1989, (2) average recruitment (42.8×10^6 recruits), 1966-2010, and high recruitment (54.8×10^6 recruits), 1966-1975. These calculations incorporate the structure of the assessment model (e.g., multi-fleet, multi-season, size- and age-selectivity) to produce results consistent with the assessment model. Projections started in 2011 and continued through 2041 under two levels of fishing mortality (constant $F_{2010-2012}$, constant $F_{2002-2004}$, constant catch averaged for 2010-2012) and three levels of recruitment (low, average, and high as defined above). Results show projected female SSB for each of the three harvest and recruitment scenarios (Figures 8 and 9). Based on these projections, the stock performs better under the constant $F_{2010-2012}$ harvest scenario than the constant $F_{2002-2004}$ harvest scenario. Assuming average historical recruitment and fishing at a constant current F, median female SSB is expected to remain

relatively stable between the 25th and median historical percentiles over both the short- and long-term, with a 13% probability that SSB falls below the SSB-ATHL threshold during a 25-yr projection period (2011-2036). In contrast, if a low recruitment scenario is assumed, then median female SSB declines under both harvest scenarios and the probability that it falls below the SSB-ATHL threshold in the 25-yr projection period increases to 65%. The high recruitment scenario is more optimistic, with median SSB increasing above the historical median SSB and the estimated probability of breaching the SSB-ATHL threshold is correspondingly low at 3%. The constant catch scenario (Figure 9) is inconsistent with current management approaches and it may be unrealistic for this stock because catches of north Pacific albacore are largely dependent on recruitment.

Biological Reference Points: Biological reference points were computed with the base case model (Table 1). The point estimate (\pm SD) of maximum sustainable yield (MSY) is 105,571 \pm 14,759 t and the point estimate of spawning biomass to produce MSY (SSB_{MSY}, adult female biomass) is 49,680 \pm 6,739 t. The SSB-ATHL threshold (i.e., the average of the ten historically lowest SSB estimates) is estimated to be 117,835 t, which is more than twice the SSB_{MSY} level. The ratio of $F_{2010-2012}/F_{MSY}$ is estimated to be 0.52 and the ratio of $F_{2010-2012}/F_{SSB-ATHL}$ is estimated to be 0.72. $F_{2010-2012}$ (current F) is below $F_{SSB-ATHL}$, F_{MSY} and all MSY-proxy reference points except F_{MED} and $F_{50\%}$ (Table 1) and these ratios are lower than ratios estimated using $F_{2002-2004}$, consistent with the intent of previous ALBWG recommendations for conservation.

The $F_{SSB-ATHL}$ reference point is currently the interim default reference point chosen by the Northern Committee of the WCPFC (NC-WCPFC). The ALBWG notes three concerns with this reference point: (1) $F_{SSB-ATHL}$ is interpreted as the fishing mortality, F, that will lead to 50% of future SSB falling below the SSB-ATHL threshold level during a 25 year projection period, (2) the time frame used to calculate the SSB-ATHL threshold was the model time frame (1966-2012), which because of changes in the spawning biomass trajectory means that there is a low SSB period in the 2000s, resulting in the use of SSBs estimated in 2007 through 2010 in the threshold calculation against which current F ($F_{2010-2012}$) is evaluated; and (3) $F_{SSB-ATHL}$ is extremely conservative if it is intended to be interpreted as a limit reference point for the stock since the point estimate of the threshold is more than twice the biomass level necessary to support MSY (i.e., $SSB-ATHL > 2 \times SSB_{MSY}$).

Conservation Advice: Based on the results of the stock assessment, the north Pacific albacore stock is not experiencing overfishing and is probably not in an overfished condition. The current exploitation level ($F_{2010-2012}$) is estimated to be below that of $F_{2002-2004}$, which had led previously to the implementation of conservation and management measures (CMMs) for the north Pacific albacore stock in the eastern Pacific (IATTC Resolution C-05-02 supplemented by Resolution C-13-03) and the western and central Pacific Oceans (WCPFC CMM 2005-03). The probability that current F will lead to SSB falling below the SSB-ATHL threshold is well below 50% under both average and high historical recruitment scenarios, but rises to 65% if a low recruitment scenario is assumed. The ALBWG notes that there is no evidence that fishing has reduced SSB below thresholds associated with the majority of biomass-based reference points that might be chosen and that population dynamics in the north Pacific albacore stock are largely driven by recruitment, which is affected by both environmental changes and the stock-recruitment relationship. The ALBWG concludes that the north Pacific albacore stock is healthy and that current productivity is sufficient to sustain recent exploitation levels, assuming average historical recruitment in both the short- and long-term.

Key Uncertainties: The ALBWG notes that the lack of sex-specific size data, the absence of updated estimates of important life history parameters (natural mortality, maturity), and the simplified treatment of the spatial structure of north Pacific albacore population dynamics are important sources of uncertainty in the assessment.

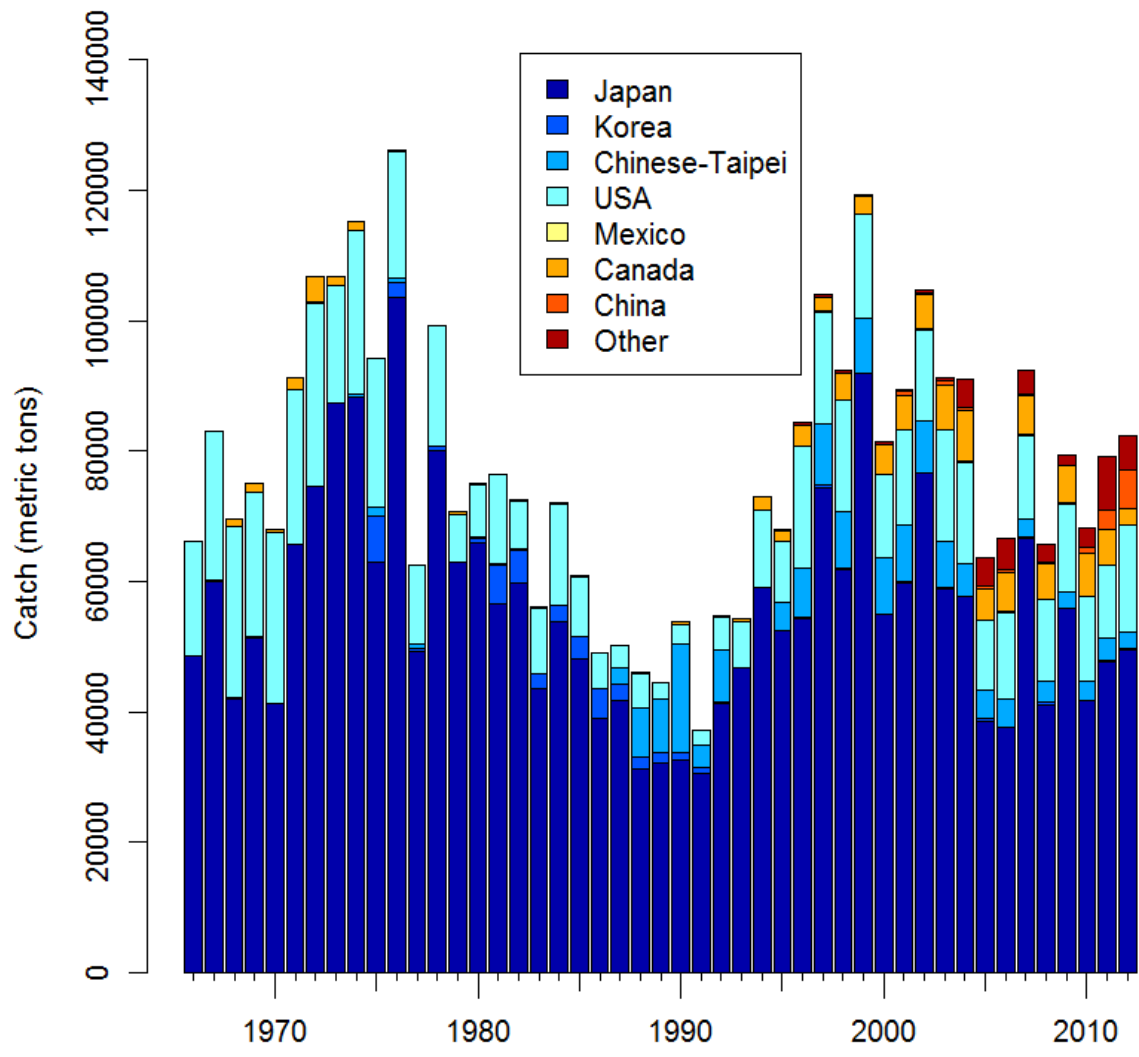

Figure 1. Total annual catch of north Pacific albacore (*Thunnus alalunga*) by all countries harvesting the stock, 1952-2012. ISC member country catches are identified. The Other category includes catches by Tonga, Belize, Cook Islands, Ecuador and Vanuatu.

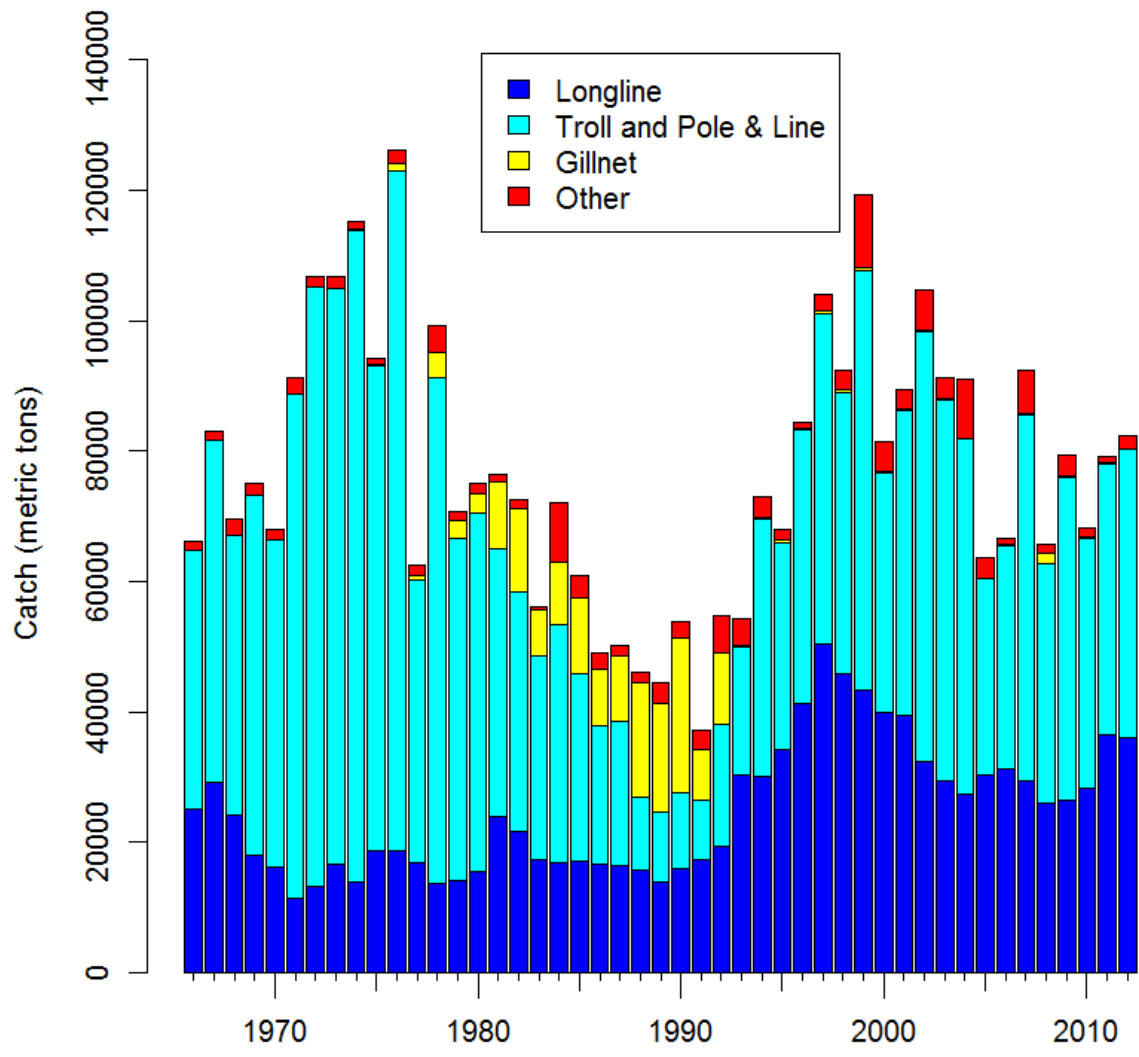
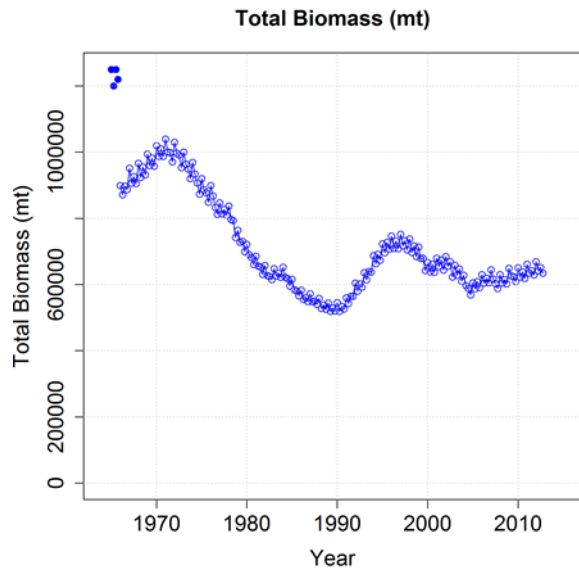
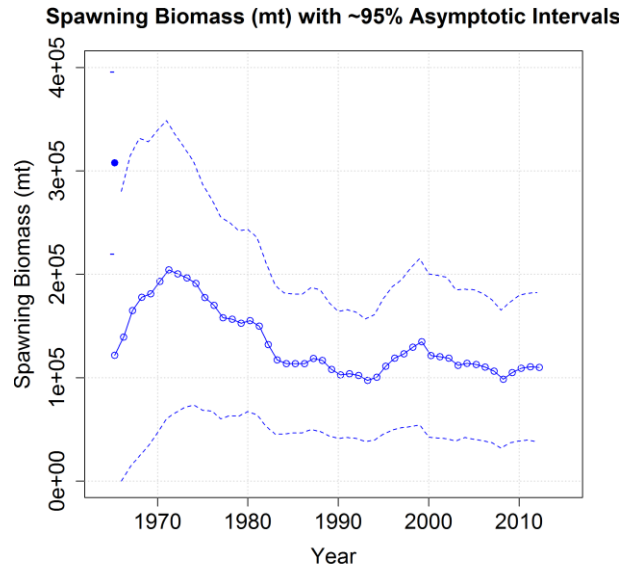

Figure 2. Catches of north Pacific albacore (*Thunnus alalunga*) by major gear types, 1966-2012. The Other gear category includes catches with purse seine, recreational gear, hand lines, and harpoons.

A.



B.



C.

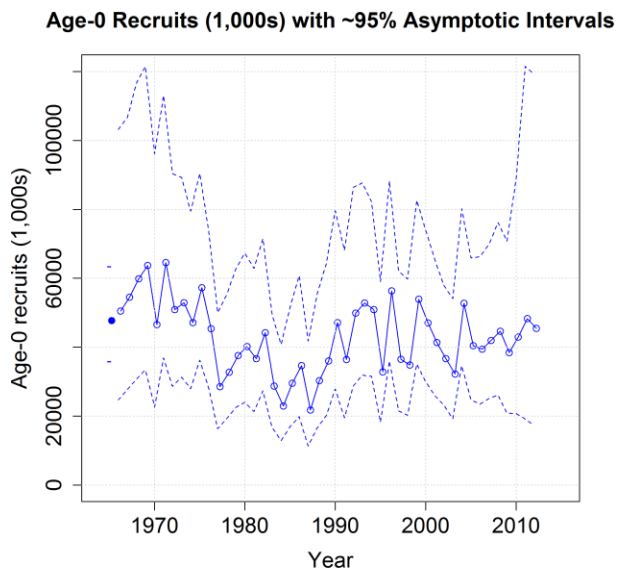

Figure 3. Estimated total age-1+ biomass (A), female spawning biomass (B), and age-0 recruitment (C) of north Pacific albacore tuna (*Thunnus alalunga*). The open circles represent the maximum likelihood estimates of each quantity and the dashed lines in the SSB (B) and recruitment (C) plots are the 95% asymptotic intervals of the estimates (± 2 standard deviations) in lognormal (SSB – B) and arithmetic (recruitment – C) space. Since the assessment model represents time on a quarterly basis, there are four estimates of total biomass (A) for each year, but only one annual estimate of spawning biomass (B) and recruitment (C).

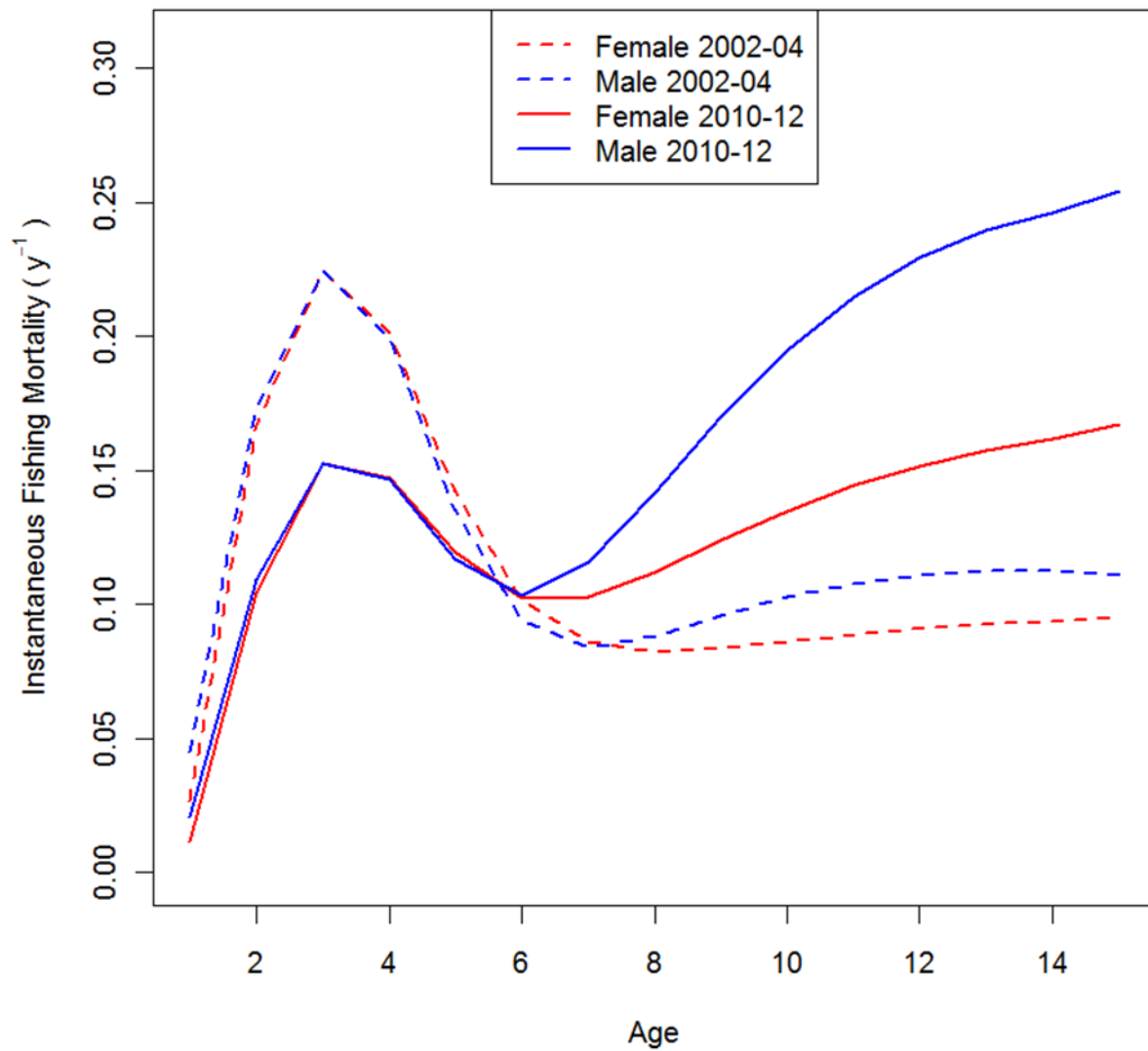

Figure 4. Estimated instantaneous fishing mortality-at-age for the 2014 base case model ($F_{2010-2012}$) and $F_{2002-2004}$ (the reference years for current management measures).

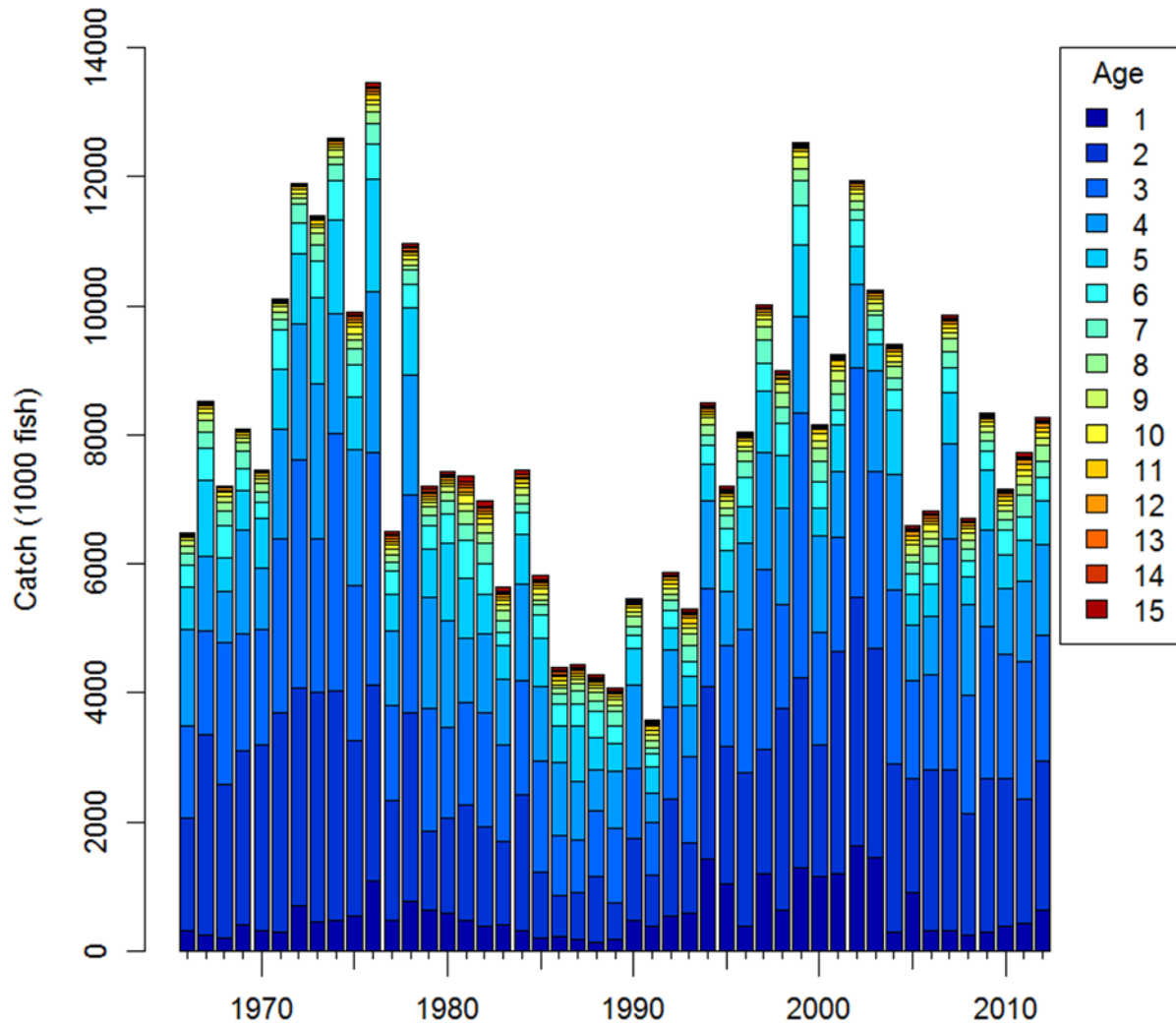

Figure 5. Historical catch-at-age of north Pacific albacore (*Thunnus alalunga*) estimated by the SS base case model for the 2014 stock assessment. The assessment model was parameterized with 15 age classes based on the oldest observed age of 15 years.

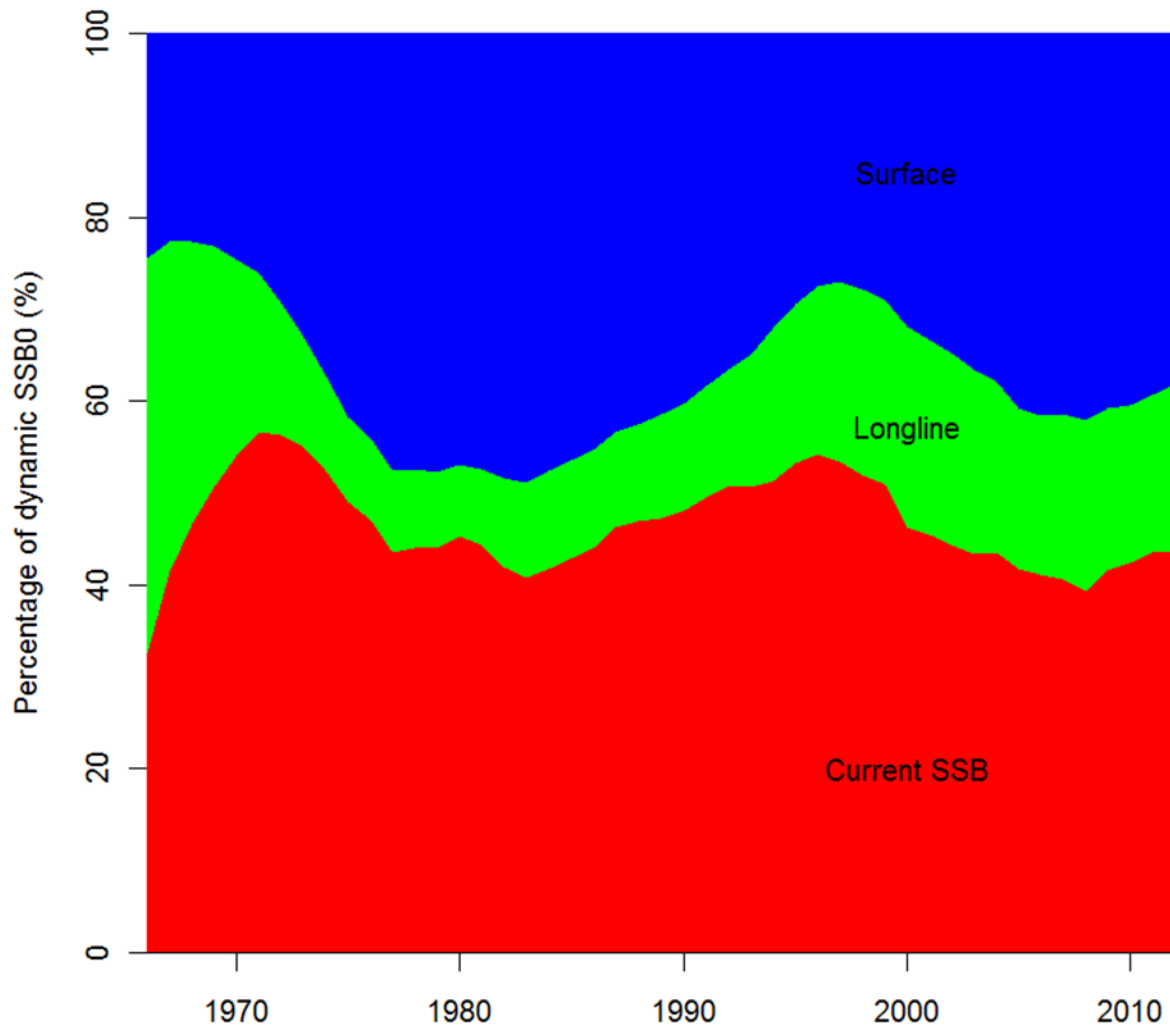

Figure 6. Fishery impact analysis on north Pacific albacore (*Thunnus alalunga*) showing current spawning stock biomass (SSB) estimated by the 2014 base case model. The shaded areas show the portions of the fishing impact attributed to longline (USA, JPN, TWN, KOR and others) and surface (USA, CAN, JPN) fisheries (primarily troll and pole-and-line gear, but including all other gears except longline).

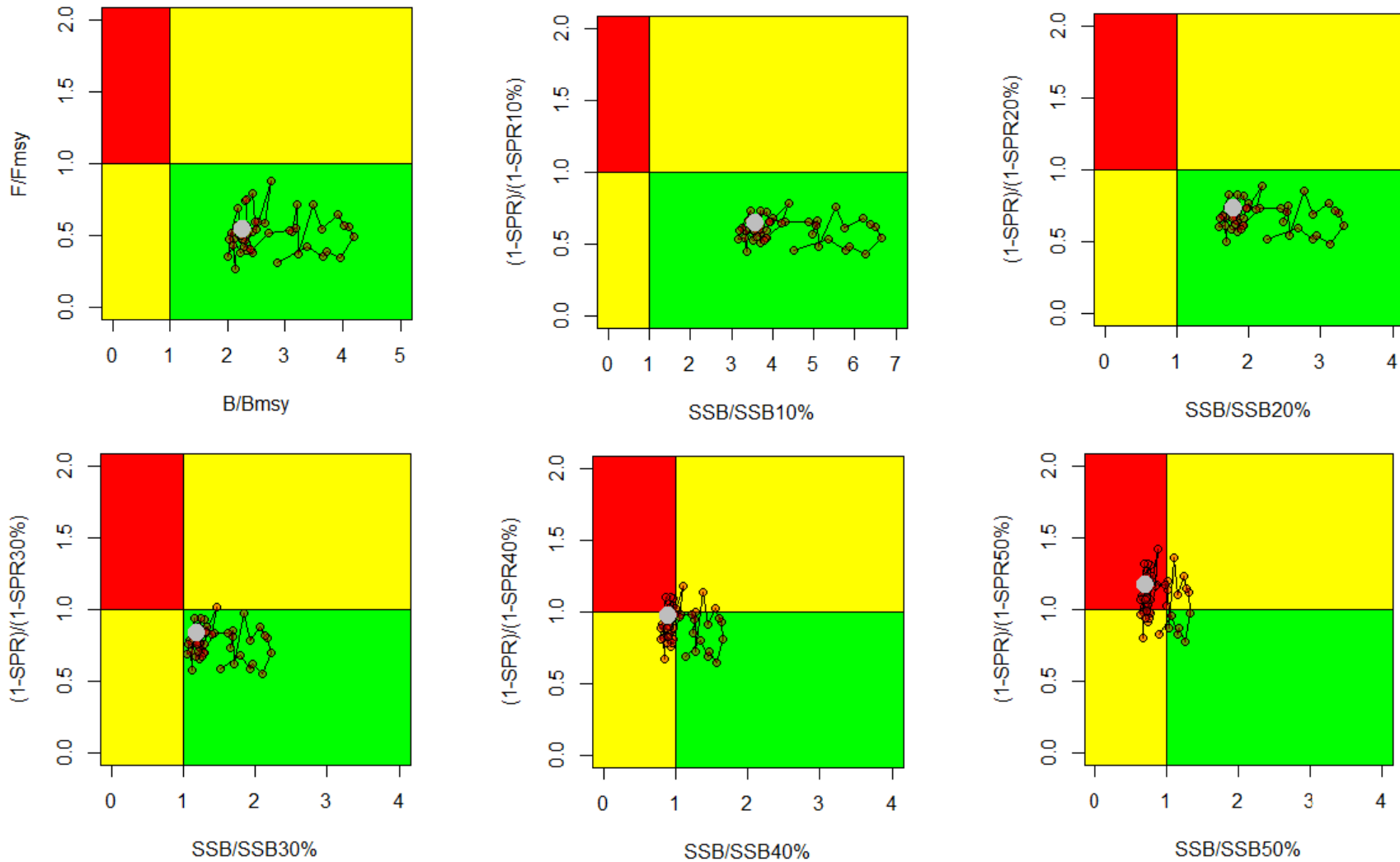

Figure 7. Alternative Kobe plots showing north Pacific albacore (*Thunnus alalunga*) stock status based on $F_{current}$ ($F_{2010-2012}$) relative to MSY-based reference points (top left) and MSY proxies consisting of SPR-based fishing intensity reference points ($F_{10\%-50\%}$) for the 2014 base case model. Grey dots are the terminal year(2012) of the assessment. These plots are presented for illustrative purposes since reference points have not been established for the north Pacific albacore stock. See the text of the assessment report regarding comments on the interim reference point $F_{SSB-ATHL}$.

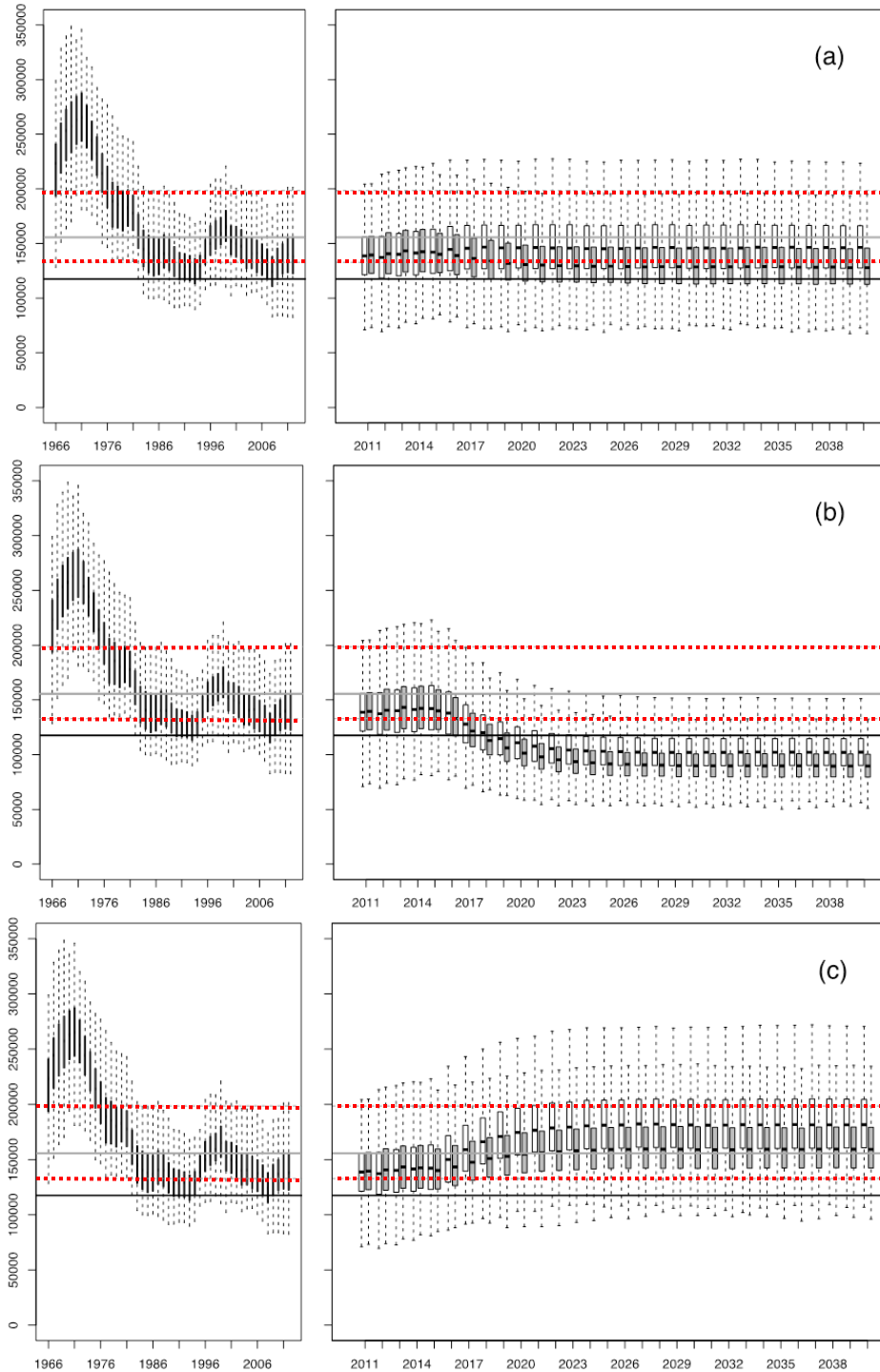

Figure 8. Historical (left) and future trajectories of north Pacific albacore (*Thunnus alalunga*) female spawning biomass (SSB) based on two constant harvest scenarios ($F_{2002-2004}$ - gray boxplot; $F_{2010-2012}$ - white boxplot) for average historical recruitment (a), low historical recruitment (b) and high historical recruitment (c) scenarios. The solid gray and red dashed lines represent median, 25% and 75% quintiles of past SSB, respectively. The solid black line is the average of 10 lowest estimated historical female SSB values, i.e., the SSB-ATHL threshold. Outlier values are not shown in these figures.

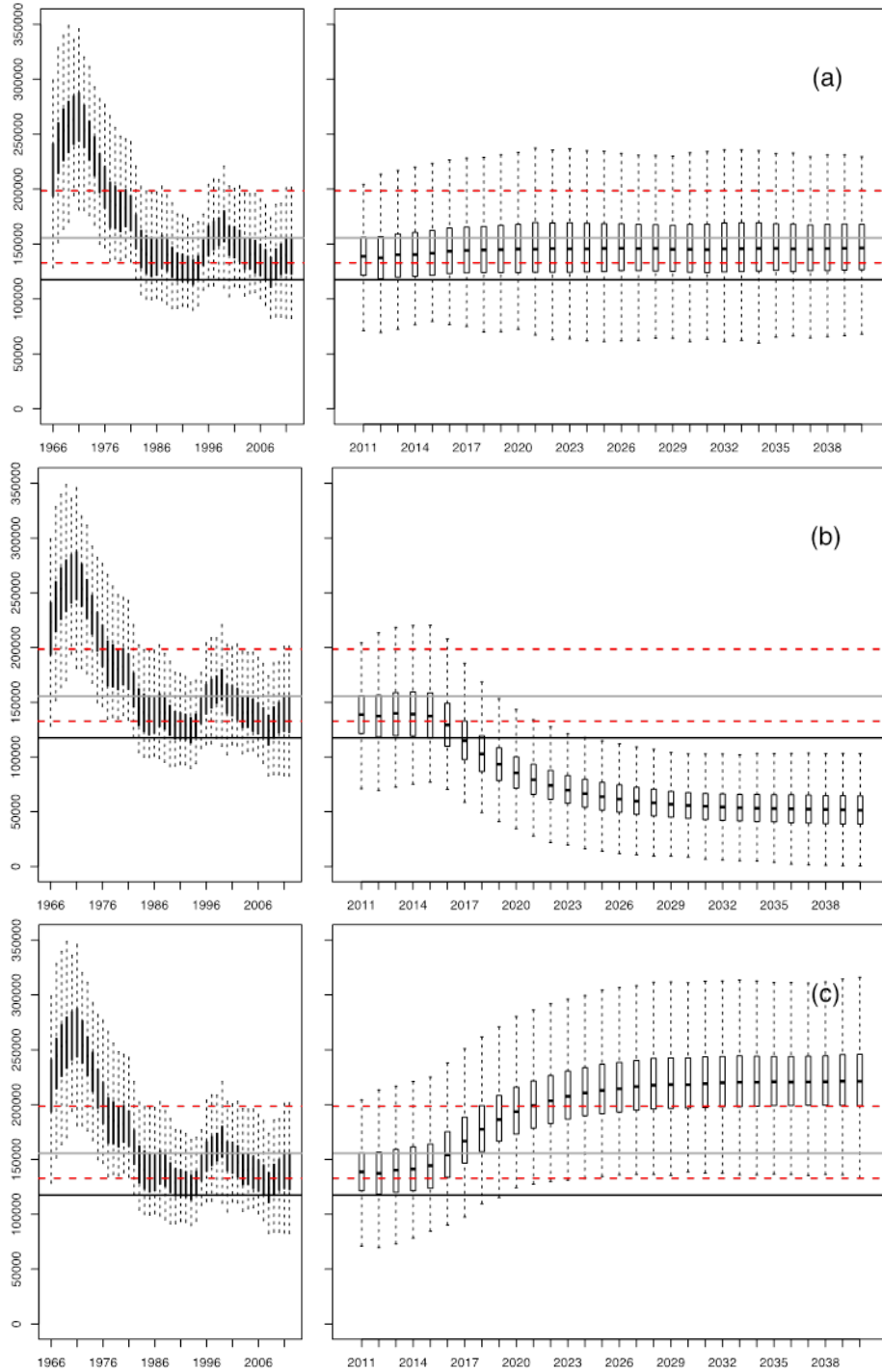

Figure 9. Historical (left) and future trajectories of north Pacific albacore (*Thunnus alalunga*) female spawning biomass (SSB) based on a constant catch harvest scenario (average of catches in 2010 to 2012, = 76,445 t) for (a) average historical recruitment, (b) low historical recruitment, and (c) high historical recruitment scenarios. The solid gray and red dashed lines represent median, 25% and 75% quartiles of historical SSB, respectively. The solid black line is the average of 10 lowest estimated historical female SSB values, i.e., the SSB-ATHL threshold. Outlier values are not shown in these figures.

1.0 INTRODUCTION

The Albacore Working Group (ALBWG) of the International Scientific Committee for Tuna and Tuna-like Species in the North Pacific Ocean (ISC) is tasked with conducting regular stock assessments of the north Pacific albacore tuna stock (*Thunnus alalunga*) to estimate population parameters, summarize stock status, and develop scientific advice on conservation needs for fisheries managers. The origins of the ALBWG date to 2005 when the *North Pacific Albacore Workshop*, which was established in 1974 to promote cooperative research and stock assessment analyses on north Pacific albacore, was integrated into the ISC. The ALBWG consists of members from coastal states and fishing entities of the region (Canada, Chinese-Taipei, Japan, Korea, Mexico, USA) and members from relevant intergovernmental fishery and marine science organizations (e.g., Inter-American Tropical Tuna Commission, Secretariat of the Pacific Community).

Previous assessments up to and including 2006 used virtual population analysis (VPA) to model north Pacific albacore stock dynamics (e.g., ALBWG 2007) and found that spawning stock biomass was largely driven by recruitment and that the fishing mortality rate (F) was high relative to commonly used F-based reference points. In addition, retrospective analyses found that stock size was often overestimated and fishing mortality rate underestimated by these earlier assessments. These assessments noted that there was uncertainty surrounding the life history and biology of north Pacific albacore including age and growth, maturity, and natural mortality (M) rates; uncertainty about the quality and completeness of available data; and uncertainty about recruitment. The 2006 assessment also reported that fishing mortality rate was high relative to commonly used reference points coupled with a decline in catch since 2002 and that a reduction in F was needed to ensure that SSB remained above the minimum observed SSB. These findings led the ISC to recommend that fishing mortality would have to be reduced and in response, the Inter-American Tropical Tuna Commission (IATTC) and the Western and Central Pacific Commission (WCPFC) implemented conservation and management measures (CMMs) to control effort at "current levels" in 2005 (IATTC Resolution C-05-02 and C-13-03; WCPFC CMM 2005-03).

The 2011 assessment of north Pacific albacore transitioned from a VPA model to an integrated, length-, and age-based forward-simulating statistical catch-at-age model in the Stock Synthesis (SS) modeling framework (Methot and Wetzel 2013) to assess current status and conduct future projections of abundance. This model included a new growth model considered to be more representative of growth in the stock, whose parameters were corroborated by conditional age-at-length data published by Wells et al. (2013). Although biomass scale was uncertain, the ALBWG concluded that fishing mortality was below F-based reference point levels and overfishing was not occurring and that stock biomass was likely not overfished, although no biomass-reference points have been established.

Independent reviews of the 2011 assessment (D. Chen 2011, Y. Chen 2011, Cordue 2011) identified several weaknesses including the lack of spatial structure, incomplete accounting for selectivity and catchability changes, the use of incoherent CPUE times series, and a somewhat arbitrary approach to weighting of data in the model structure. In the years since these reviews were completed, there have been advances in knowledge of albacore biology, including improved understanding of the growth rates of juveniles and sex-specific growth rates of adults (Chen et al. 2012; Wells et al. 2013), the stock-recruitment relationship (Brodziak et al. 2011; Iwata et al. 2011), the movements, habitat use and behaviour of albacore (Childers et al. 2011; Cosgrove et al. 2014), catchability and selectivity changes, and structuring of the population model. Many of these advances were incorporated into the 2014 assessment model.

This report presents the results of the 2014 assessment of north Pacific albacore tuna and scientific advice on stock conservation needs to fisheries managers. The assessment uses new estimates of the stock-recruitment relationship and sex-specific growth models and updated fishery data through 2012 in a length-based, age-structured, integrated statistical stock assessment model fitted to abundance indices from the Japan pole-and-line and longline fisheries, which are considered representative of juvenile and adult abundance, respectively. Catchability of these indices and selectivity of fisheries were allowed to vary over time following analyses of changes in fishery operations or likely changes in albacore movement patterns. The assessment was conducted 14-28 April 2014 at the Southwest Fisheries Science Center, La Jolla, California, USA, and supersedes the 2011 assessment results (ALBWG 2011). The objectives of the 2014 assessment are to (1) understand the dynamics of north Pacific albacore tuna by estimating population parameters such as time series of recruitment, biomass and fishing mortality, (2) determine stock status by summarizing results relative to a suite of biological reference points, including MSY-based reference points, and (3) to formulate scientific information on conservation needs for fisheries managers based on projections using constant fishing mortality and constant catch scenarios.

2.0 BACKGROUND

2.1 Biology

2.1.1 Stock Structure

Albacore tuna in the Pacific Ocean consist of the north Pacific stock (focus of this assessment) and the south Pacific stock. The discreteness of these stocks is supported by fishery data (lower catch rates in equatorial regions; Suzuki et al. 1977), tagging data (fish tagged in the north Pacific Ocean have not been recovered in the south Pacific Ocean; Ramon and Bailey 1996), ecological data (albacore larvae are rare in samples from equatorial waters; Ueyanagi 1969), and genetic data (showing differentiation between north and south Pacific albacore; Takagi et al. 2001). Thus, north Pacific albacore are assumed to be a discrete, reproductively isolated stock, with no internal sub-group structure within the stock.

2.1.2 Reproduction

Albacore are batch spawners, shedding hydrated oocytes in separate spawning events directly into the sea where fertilization occurs. Spawning frequency is estimated to be 1.7 d in the western Pacific Ocean (Chen et al. 2010), and batch fecundity ranges between 0.17 and 2.6 million eggs (Ueyanagi 1957; Otsu and Uchida 1959; Chen et al. 2010). Female albacore mature at lengths ranging from 83 cm fork length (FL) in the western Pacific Ocean (Chen et al. 2010) to 90 cm FL in the central Pacific Ocean (Ueyanagi 1957), and 93 cm FL north of Hawaii (Otsu and Uchida 1959).

Spawning occurs in tropical and sub-tropical waters between Hawaii (155°W) and the east coast of Taiwan and the Philippines (120°E) and between 10 and 25°N latitudes at depths exceeding 90 m (Ueyanagi 1957, 1969; Otsu and Uchida 1959; Yoshida 1968; Chen et al. 2010). Although spawning probably occurs over an extended period from March through September in the western and central Pacific Oceans, recent evidence based on a histological assessments of gonadal status and maturity (Chen et al. 2010) shows that spawning peaks between March-April in the western Pacific Ocean, which is consistent with evidence from larval sampling surveys in the same region (Nishikawa et al. 1985). In contrast, studies of albacore reproductive biology in the central Pacific Ocean have concluded that there is a probable peak spawning period between June and August (Ueyanagi 1957; Otsu and Uchida 1959), but these studies are based on indirect observation methods, are more than 50 years old, and did not use modern histological techniques (e.g., see Chen et al. 2010).

2.1.3 Growth

Growth among albacore is commonly modeled by a von Bertalanffy growth function, with rapid growth in immature fish followed by a slowing of growth rates at maturity and through the adult period. Growth in the first year of life is uncertain since these young fish are rarely captured in any of the active fisheries in the north Pacific Ocean. However, juvenile albacore recruit into intensive surface fisheries in both the eastern and western Pacific Oceans at age 2 and as a result, much better size-at-age and growth information is available. Early growth models combined both sexes because sex-specific fishery data were not collected, although it was known that adult males attained a larger size than females (Otsu and Uchida 1959; Otsu and Sumida 1968; Yoshida 1975). Chen et al. (2012) provided clear evidence of sexually dimorphic growth in north Pacific albacore after they reach sexual maturity and reported that males attained a larger size and older age than females (114 cm FL and 14 years vs. 103.5 cm FL and 10 years, respectively). Estimated size at age-1 in north Pacific albacore ranges from 45 to 64 cm FL (Clemens 1961; Chen et al. 2012; Wells et al. 2013). Albacore are ~ 60 cm FL at age 2 when they recruit into surface fisheries and grow at a rate of about 10 cm per year for ages 2-4. Growth slows further after 5-6 years of age when albacore are mature (Clemens 1961; Otsu and Uchida 1959; Yabuta and Yukinawa 1963; Chen et al. 2012; Wells et al. 2013). The maximum recorded size of a north Pacific albacore is 128 cm FL (Otsu and Uchida 1959; Clemens 1961) and the oldest known age is 15 years (Wells et al. 2013).

A re-examination of the age and growth data compiled by Wells et al. (2013), some of which were used as conditional age-at-length data in the 2011 assessment, showed that for those individuals in which sex was recorded, there was clear evidence of sexually dimorphic growth between males and females (Xu et al. 2014a). These authors also compared the size composition of albacore sampled by Wells et al. (2013) to the size composition of albacore caught by the US longline deep-set fishery targeting bigeye tuna (*T. obesus*) near Hawaii and concluded that the samples used by Wells et al. (2013) preferentially focused on larger fish from this fishery, which tend to be male. This oversampling of larger and older male albacore may have biased the resulting sex-combined growth model used in the 2011 assessment because of the higher proportion of male fish in the samples of large fish (Xu et al. 2014a). Given the clear evidence of sexual dimorphism in the growth and longevity of north Pacific albacore, the ALBWG used sex-specific male and female von Bertalanffy growth functions estimated externally to the stock assessment model by Xu et al. (2014a), who combined the sex-specific datasets compiled by Chen et al. (2012) and Wells et al. (2013) (Section 4.2.2).

2.1.4 Movements

North Pacific albacore are highly migratory and these movements are influenced by oceanic conditions (e.g., Polovina et al. 2001; Zainuddin et al. 2006, 2008). The majority of the migrating population is believed to be composed of juvenile fish (i.e., immature animals less than 5 years old and 85 cm FL), which generally inhabit surface waters (0-50 m) in the Pacific Ocean. Some juvenile albacore undertake trans-Pacific movements from west to the east and display seasonal movements between the eastern or western and central Pacific Ocean (Ichinokawa et al. 2008; Childers et al. 2011). The trans-Pacific movements track the position of the transition zone chlorophyll front (Polovina et al. 2001; Zainuddin et al. 2006, 2008) and increase when large meanders in the Kuroshio current occur, increasing albacore prey availability in the transition zone (Kimura et al. 1997; Watanabe et al. 2004). Westward movements of juveniles tend to be more frequent than eastward movements (Ichinokawa et al. 2008), corresponding to the recruitment of juvenile fish into fisheries in the western and eastern Pacific Ocean and are followed by a gradual movement of maturing juveniles and mature fish to low latitude spawning grounds in the western and central Pacific Ocean. This pattern may be complicated by sex-related movements of large adult fish (> 125

cm fork length, FL), which are predominately male, to areas south of 20°N (e.g., see Kiyofuji et al. 2014). The significance of sex-related movements on the demographic dynamics of this stock are uncertain at present.

2.2 Fisheries

Albacore tuna is a valuable species with a long history of exploitation in the north Pacific Ocean. The total reported catch of north Pacific albacore for all nations combined (Figure 2.1) peaked at 126,175 metric tonnes (t) in 1976 and then declined to the lowest observed catch in the time series (37,274 t) in 1991. Following this low point, total catch recovered to a second peak of 119,297 t by 1999. Total catch declined through the 2000s to a low of 63,654 t in 2005 and has recovered slightly to between 65,000 and 92,000 t in recent years (2006-2012). Median catch over the model time frame (1966-2012) is 72,439 t and average annual catch for 1981-2010 is 72,128 t. During the last decade (2003-2012), Japan accounted for 63.5% of the total harvest on average annually, followed United States, which accounted for 17.7%, 7.3% by Canada, 4.9% by Chinese Taipei, 1.6% by China, and 0.27% by fisheries in Korea and Mexico combined. Other non-ISC member countries targeting north Pacific albacore during this period accounted for 4.6% of the reported harvest and include Tonga, Belize, Cook Islands, Vanuatu, Vietnam, and Ecuador (Figure 2.1).

The main gears deployed to harvest albacore in the north Pacific Ocean are longline, pole-and-line, and troll (Figure 2.2). Surface fisheries capture smaller, juvenile fish, and include the USA and Canada troll and pole-and-line fisheries and the Japan pole-and-line fisheries. Surface fisheries have harvested approximately 60% of the north Pacific albacore catch since 1966. Longline fisheries, which fish deeper in the water column and tend to capture larger, mature albacore, are responsible for harvesting 32% of the albacore during the same period, with major fleets from Japan, USA, Taiwan, and recently, China. Catches by all gears were relatively high in the 1970s, especially pole-and-line catch, and then declined to their lowest levels by the late 1980s. This decline was followed by a rebuilding phase ending with a second peak in catch by the late 1990s in all gears. Through the 2000s catches have either declined steadily (longline) or stabilized at lower levels than the peak in the 1990s (troll, pole-and-line). Pole-and-line catches in the 2000s exhibit greater year-to-year variability than catches by the other gear types since they are influenced by target switching between skipjack (*Katsuwonus pelamis*) and albacore by some vessels on the fishing grounds off the east coast of Japan (Kiyofuji and Uosaki 2010). High gillnet catches of albacore in the 1980s reflect data from high seas driftnet fisheries, which began in 1978 and ceased operating in 1993 as a result of United Nations General Assembly Resolution 44/225, which put in place a moratorium on the use of high seas driftnets (Uosaki et al. 2011).

3.0 DATA

Three types of data were used in this assessment: fishery-specific catches, size compositions, and abundance indices. These data were compiled from 1966 through 2012. Data sources and temporal coverage of the available datasets are summarized in Figure 3.1.

3.1 Spatial Stratification

The geographic area encompassed in the assessment is the Pacific Ocean north of the equator (0°) to 55°N latitude and from 120°E to 100°W longitude (Figure 3.2). This area includes all of the known catches of north Pacific albacore from 1966 through 2012. The base case model is not spatially explicit but fisheries were defined using multiple criteria, including fishing area, and therefore implicitly included spatial inferences (Table 3.1).

3.2 Temporal Stratification

The time frame for the 2014 assessment is 1966–2012. The assessment is based on data available to the ALBWG as of 1 January 2014 and does not reflect changes to 2012 catch data, which were considered preliminary during the assessment, that occurred after this date. Catch and size composition data were compiled into quarters (Jan–Mar, Apr–Jun, Jul–Sep, Oct–Dec) and a quarterly time step was used for biomass estimation. Although some catch data time series extended back to at least 1952, these data were not used in the base case model because effort and size composition data are not consistently available prior to 1966 and the location information associated with pre-1966 catches is not always reliable. Nevertheless, sensitivity runs were conducted to evaluate the effect of different starting years on estimated quantities (Section 4.7).

3.3 Fishery Definitions

Twenty-four (24) fisheries were defined for the assessment on the basis of gear, fishing area, season, the unit of catch (numbers or weight), and time range and all catch and effort data were allocated to these fisheries (Table 3.1). The aim was to define relatively homogeneous fisheries with greater differences in selectivity and catchability among fisheries than temporal changes in these parameters within fisheries. This approach allowed the ALBWG to use differences in selectivity between fisheries as proxies for movement between fishing areas (Hurtado-Ferro et al. 2014; Waterhouse et al. 2014) since movement information is not available. These fisheries consisted of three surface [EPO surface (primarily Canada and USA); Japan pole-and-line], and 21 longline fisheries (USA, Japan, and Taiwan albacore targeting and non-albacore targeting).

Albacore catches for several minor fisheries were combined with one of the 24 fisheries defined above based on similarities in gear and operational area. These minor fisheries were originally configured separately, but during model development the ALBWG concluded that model computation speed was vastly improved by combining catches from these minor fisheries into larger operationally equivalent fisheries as shown in Table 3.1. Korean longline catches were included in F8 (JPLLNw_Q14) and F12 (JPLLNw_Q14 for the 1975-1993 period) because they operate in similar areas and span the period 1971 to 2012, gillnet fisheries in Korea, Taiwan and Japan were combined with F1 (JPPL_Q12), as were catches from miscellaneous gears in Japan (e.g., set net, purse seine, troll). Mexican catches were included in F7 (EPO surface fishery) and Japan longline catches in the eastern Pacific Ocean (EPO) south of 25°N were combined with F23 (TWNLLb - Taiwan non-albacore targeting longline fishery). Catches from China and non-ISC member countries were combined with F20 (USLLd – the deep-set longline fishery operating out of Hawaii targeting bigeye tuna). The operational areas of all 24 fisheries are shown in Figure 3.3.

The majority of the 24 fisheries were based on subsets of the Japan longline fisheries. All of the Japan longline fisheries are seasonal fisheries (Q14 and Q23) because preliminary analysis revealed that there were seasonal changes in selectivity. Since some Japan longline vessels report catch as weight and some report catch as number of fish, the ALBWG chose to define longline fisheries in most areas that are identical except for the catch units to avoid catch unit conversion issues. Further analysis of the Japan longline fisheries prior to the assessment workshop (Satoh et al. 2014; Kiyofuji et al. 2014) identified two issues: (1) latitudinal changes in selectivity in the main longline fishery (F8), and (2) a temporal change in the assumed selectivity pattern in the main Japan longline fishery (F8) in the 1975-1993 period, relative to the remaining time blocks (1966-1974, 1994-2012). The ALBWG divided the main Japan longline fishery (F8) into two area-based fisheries using 20°N as the boundary: south of 20°N, the largest fish (>100 cm FL) predominate in catches while north of 20°N, smaller fish predominate in the catches (Kiyofuji et al. 2014). This spatial stratification was applied to both the number-based and weight-based fisheries defined for this

fleet. The ALBWG also noted that size composition of the catches in the main Japan longline fishery during the 1975-1993 period were much different than in earlier or later periods: the 1975-1993 period was characterized by high catches of large fish, which may have been due to higher movement rates of large fish into these fishing areas during this period. As a result, this period was separated into a unique fishery and logistic selectivity was assumed: the other periods were characterized by dome-shaped selectivity functions. In total, 12 fisheries were defined with relatively constant size compositions (selectivity) over time from the main Japan longline data based on season, area, catch units, relative size of fish caught, and time block (see ALBWG 2014 for a more detailed discussion of fishery definitions).

3.4 Catch and Effort

Estimates of total catch in each fishery (Table 3.1) were compiled by calendar quarter for 1966-2012. Catch data from some of the minor fisheries were only available as annual values so these catch data were assumed to be constant on a quarterly basis and the annual figures were divided by 4 to estimate quarterly catch. Catch was reported and compiled in original units consisting of weight (F1- F4, F7 - F9, F12, F13, F16, F17, F20, F21) and numbers of fish (F5, F6, F10, F11, F14, F15, F18, F19, F22 - F24).

Effort data were compiled from logbooks for 19 fisheries (F1, F2, F3-F6, F7, F8-F15, F20, F22, F23, F24) and used to calculate relative abundance indices for 10 fisheries (F1, F2, F3, F4, F7, F8, F12, F20, F22, F24) (see Section 3.5). Nominal effort data in the form of number of vessels are also reported by ISC member countries and were compiled by the ALBWG. The number of vessels fishing each of the major gears (Figure 3.4) has either decreased (longline, troll) or remained relatively stable (pole-and-line, purse seine) since the 1990s. Surface fisheries are highly seasonal, occurring mainly from May through October whereas longline fisheries operate throughout the year, although there is a strong seasonal trend in the catch distribution, with the first and fourth quarters (October-March) producing the largest annual catches. Records of the number of vessels for each country and gear combination (fleets) only date back to the early 1970s or 1980s.

3.5 Relative Abundance Indices

Catch and effort data were aggregated into monthly $1^\circ \times 1^\circ$ (surface fisheries) or $5^\circ \times 5^\circ$ (longline fisheries) strata for standardization using generalized linear model (GLM) approaches. A total of eleven standardized indices of annual relative abundance were developed for consideration during the 2014 stock assessment process. These indices consisted of seven juvenile indices (S3, S4, S6, S7, S8, S9, S10) and four adult indices (S1, S2, S5, S11) as shown below.

Index	Time Period	Fishery Data
S1 - JPLLL	1975-1992	F12 - JPLLLNw_Q14
S2 - JPLLL	1993-2012	F8 - JPLLLNw_Q14
S3 - JPPL	1972-1989	F1 - JPPL_Q12
S4 - JPPL	1990-2012	F2 - JPPL_Q34
S5 - TWNLLa	1995-2011	F22 - TWNLLa
S6 - JPLLS	1975-1988	F5 - JPLLSn_Q12
S7 - JPLLS	1989-2012	F5 - JPLLSn_Q12
S8 - EPO	1966-1978	F7 - EPO
S9 - EPO	1979-1998	F7 - EPO
S10 - EPO	1999-2012	F7 - EPO
S11 - USLLd	1991-2012	F20 - USLLd

These eleven indices originally consisted of six indices of longer duration (Table 3.2). However, the indices were divided into shorter time periods because the ALBWG concluded that operational changes in these fisheries, as described below, probably led to changes in catchability between time periods (see below and ALBWG 2013). Dividing the time series allows the SS model to estimate different catchabilities for each time period. This improvement is a response to the criticism by reviewers of the 2011 assessment (e.g., Cordue 2011) that the ALBWG had unrealistically assumed constant catchability for abundance indices for over four decades.

3.5.1 S1 and S2 – Japan Longline

The main Japanese longline index (based on F8 and F12) was divided into two time blocks (S1 - 1975-1992, S2 - 1993-2012) because of operational changes in the fishery: 1) expansion of fishing grounds north of 25°N in the early period and south to 10°N in the later period; 2) a switch from shallow-sets to deep-sets; and 3) a change in the primary fishing season from Q1 and Q4 to Q2 and Q3 between the early and later periods (Ijima et al. 2013; Ijima and Satoh 2014). Negative binomial generalized linear models (GLM) were used to standardize catch-per-unit-effort (CPUE) for each period because the catch data were number of fish and the proportion of sets with zero albacore catch was not substantial (<25%; Ijima and Satoh 2014). These data were standardized using four statistical areas and quarterly definitions and five main effects in the model including year, quarter, number of hooks per basket (gear effect), 5°x 5° area, and fleet type (coastal, offshore and distant water, based on vessel size). Interaction terms were not used in the standardization procedure.

3.5.2 S3 and S4 – Japan Pole-and-Line

The JPPL indices (S3, S4) are based only on data from the distant-water component of the pole-and-line fishery (F1) to minimize the influence of target switching between albacore and skipjack (*Katsuwonus pelamis*) in segments of the offshore pole-and-line fleet. The catch and effort data were separated into two time blocks (1972-1989, 1990-2012) and standardized separately (Kiyofuji 2014) because preliminary analysis of a single index showed a large change in scale in the late 1980s-early 1990s that is believed to be related to operational changes in the fishery since the seasonality of catch switched from Q1 and Q2 in the early period to Q3 and Q4 in the later period (Kiyofuji and Ijima 2013). Both time blocks were standardized with a delta-lognormal model using year, quarter, and area (1°x1° strata) as explanatory variables. An attempt was made to account for technological change in the standardization process (e.g., introduction of low temperature bait tanks, sonar, satellite meteorological information receivers, bird radar) through a Vessel ID variable, but the inclusion of this variable did not improve model fit relative to the model lacking this variable (Kiyofuji 2014).

3.5.3 S5 – Taiwan Albacore-Targeting Longline

Sub-areas were defined in the TWN LL fishery data based on the similarity of catch compositions in each 5°x5° spatial stratum in order to standardize CPUE using a GLM (Chen and Cheng 2013). Based on the results of cluster analysis and discriminant function analysis (DFA) classification success, an albacore-targeting fishery was defined operating primarily in the waters north of 25°N and using fewer than 13 hooks per basket in its operations. The majority (98%) of Taiwanese albacore catch is contributed by the albacore-targeting fishery. CPUE data from the albacore-targeting fishery (S5) were standardized using year, season, area (5°x5° stratum), and an interaction term as explanatory variables in the GLM.

3.5.4 S6 and S7 – Japan Longline

Two additional indices (S6 and S7) were also developed from a subset of the Japanese longline fishery targeting albacore in a 10° x 10° area (25-35°N and 130-140°E) (Ijima et al. 2013; Ijima and

Satoh 2014). The albacore caught in this area were juveniles and smaller than albacore caught in other areas by the Japan longline fleet, consistent with some juvenile-specific movements into this area. Most of the albacore are caught in Q1 and Q2, which consists of smaller fish than that caught in Q3 and Q4. The CPUE data for S6 and S7 were standardized with a model similar to the one used to standardize S1 and S2 (Section 3.5.1).

3.5.5 S8, S9, and S10 – EPO Surface Fisheries

Three indices (S8, S9, S10) were developed from the EPO surface fishery data (merged Canadian and US troll and pole-and-line fishery data) and are based on the data-rich coastal time series (east of 140°W) from 1966 to 2011 because there was insufficient effort in the open ocean to provide a representative index (Xu et al. 2014b). The time series was divided into three time blocks (1966-1978, 1979-1998, 1999-2011) corresponding to operational changes in the fishery. Year, area (1°x1° strata), and season were used as explanatory variables in a lognormal GLM to standardize the EPO surface fishery data and confidence intervals were determined with bootstrapping (Xu et al. 2014b). Data from 2012 were not used in the standardization process because access provisions in the bilateral Canada-United States Albacore Tuna Treaty were suspended, changing fishery operations in each country relative to previous years (ALBWG 2013).

3.5.6 S11 – USA Deep-set Longline

An abundance index (S11) was developed from the USA deep-set longline fishery based in Hawaii (see Teo et al. 2010) using catch and effort data from 1991 (start of the vessel logbook program) to 2012 (terminal year of the assessment). This time series was not divided into time blocks since it is relatively short compared to the Japan longline time series. A delta-lognormal model was used to standardize the index, with year, area, and season as explanatory variables. Confidence intervals were determined with bootstrapping. The operational area of the USA deep-set longline fishery is typically south of 25°N, near the Hawaiian Islands, and is substantially smaller than the Japan longline fishery. The primary target of this fishery is bigeye tuna.

3.5.7 Observed Abundance Trends

Visual inspection of the juvenile indices (S3, S4, S6, S7, S8, S9, S10) shows that long-term trends are similar and appear to be in phase through the 2000s, although they exhibit different magnitudes of variability (Figure 3.5). The indices (S6, S7) based on Japan coastal longline fishery (F3, F5) are considered juvenile indices because this fishery targets small-sized albacore (about 80 cm FL) in Q1 and 2 of each year. The EPO index (S8) lacks contrast early in the time series relative to the JPPL index (S3). The JPPL index (S3, S4) is considered to be the most representative of juvenile abundance because the spatial coverage is much broader than either the EPO (S8, S9, S10) or the JPLLS (S6, S7) indices (ALBWG 2014).

The JPLLL index (S1) shows a declining trend the 1970s and 1980s and an increase in the early 1990s followed by a decline to the early 2000s and then a modest increasing trend to the present (Figure 3.6). Both TWNLLa index (S5) and the USLLd index (S11) exhibit a large increase in the mid-1990s that occurs earlier than observed in S2. Both increases are followed by sharp declines to the earlier 2000s and then differing trends to the present, with S5 showing an increase, consistent with S2 (JPLLL), and S11 continuing to decline before flattening out in recent years. The spike in S5 and S11 in the mid-1990s might be related to the concentration of effort by their respective fisheries into small spatial area during this period (ALBWG 2013). The USLLd index (S11) was also affected by regulatory changes that probably were not fully removed during standardization (Figure 3.5). The JPLLL indices (S1, S2) are considered to be the most representative index of adult abundance in the north Pacific albacore stock. This fishery records the highest proportion of the

total albacore catch and it occurs over a large area with consistent effort in time and space whereas the TWNLLa (S5) and USLLd (S11) fisheries occur in smaller areas and over shorter time periods.

3.5.8 Base case Model Indices

Based on the analysis described above and in more detail by ALBWG (2013, 2014), the base case assessment model was fitted to the JPPL (S3, S4) and JPLLL indices (S1, S2) only. These decisions are based on two important assumptions: (1) juvenile movements dynamics are adequately accounted for in the JPPL indices (S3, S4), which seems likely given the broad spatial coverage and long temporal history of this fishery, and (2) the majority of adult biomass occurs in the western and central Pacific Ocean where the JPLLL fishery (indices S1, S2) primarily operates. The current understanding held by the ALBWG of juvenile migration dynamics and adult habitat are consistent with these assumptions. The choice and the rationale for fitting to juvenile and adult abundance indices in the base case model or using an index as a sensitivity run are described in Table 3.2.

Some of the indices not fitted in the base case model are used as sensitivity runs to test alternate hypotheses concerning trends in abundance of juvenile and adult albacore. The TWNLLa (S5) and USLLd (S11) indices will test the impact of alternative trends in adult abundance and sensitivity runs with the EPO (S8, S9, S10) and JPLLS (S3, S4) indices will test the effect of alternative trends in juvenile abundance on model output (see Section 4.7).

Standardized annual values and input CVs for the indices used in the base case model and sensitivity runs are shown in Table 3.3. Seasons were assigned to each index based on the annual quarter(s) in which the majority of catch was recorded. The relative weighting of the indices were controlled by adjusting the input CVs of the indices (Section 4.4).

3.6 Size Composition

Quarterly length composition data from 1966 to 2012 are used in this assessment. Length data were available for 15 of the 24 fisheries defined for the base case model (Table 3.1) and were compiled into 2-cm size bins, ranging from 26 to 142 cm FL, where the labels are the lower boundary of each bin. Each length frequency observation consisted of the actual number of albacore measured. Most of these fisheries exhibit clear modes when lengths are aggregated across quarters and years and sex throughout the time series (Figure 3.6). The length data for F1 and F2 (JPPL) exhibited exceptionally high variability in the number of modes and mean sizes between seasons and years. The majority of size composition data in the JPPL fishery are collected in Q2, but similar variability is observed in Q1. Since the size composition data were not raised to the catch in any fishery, this inter-annual variability is treated as observation error in the base case model. An alternative explanation is that this variability is process error related to inter-annual variability in juvenile movement patterns that is not adequately captured because the base case model is not spatially explicit.

The majority of albacore length composition data are collected through port sampling or on-board sampling by vessel crews or observers. Length data for the Japan longline (F3, F8, F12) and pole-and-line fisheries (F1, F2) were measured to the nearest cm at the landing ports or onboard fishing vessels from which catch-at-size data were derived (see Matsumoto and Uosaki 2011). Fork lengths of albacore in the EPO surface fishery (F7) were compiled from port samples of the USA troll and pole-and-line fisheries (Teo et al. 2010). Although length composition data are available for the Canadian component of this fishery, these data were not used because the USA and Canada components of the fishery overlap greatly in their fishing areas and the data from the USA component were thus considered representative of the entire fishery. Length compositions for the USA LL fishery were collected by observers. Albacore lengths for the TWNLLa fishery (F22 -

albacore targeting) were measured onboard fishing vessels and compiled for 1995 to 2012 by the Overseas Fisheries Development Council (OFDC), Taiwan (Chen and Cheng 2013). The length composition data prior to 2003 are not considered representative of catches by this fishery because they were sampled from a restricted geographic area and shorter annual time period than the spatial and temporal scope at which the fishery was operating (ALBWG 2011). Thus, only the 2003-2012 length data are considered representative of the catch and were used in the 2014 base case model; data prior to 2003 were not used.

Size distributions and mode positions vary by fishery (Figure 3.6). Surface fisheries using pole-and-line or troll gear (F1, F2, F7) tend to have relatively broad distributions with 2-3 modes at sizes less than 80 cm FL. The size distribution of the catch in the Japan coastal longline fishery targeting juvenile albacore (F3, F4) is consistent with the juvenile size distributions in surface gear fisheries. Size distributions of the catch in longline fisheries (F8, F9, F12, F13, F16, F17, F20, F21, F22, F24) are skewed to sizes greater than 80 cm FL and typically exhibit a single mode near 100 cm FL. Both F16 and F17 exhibit relatively narrow size distributions with modes at about 120 cm FL (Figure 3.6), which means these fisheries are catching the largest albacore in the north Pacific Ocean. These fisheries are Japan longline fisheries operating south of 20°N in Quarters 1 and 4 and 2 and 3, respectively.

Effective sample sizes of the length composition data controls the relative weighting of that data component in the total likelihood function, and is therefore important in the assessment model. See Section 4.4 and 4.5 for details on the effective sample sizes and relative weighting of data components.

3.7 Sex Ratio

Size composition data from the Japan training vessel longline catches collected from 1987 to the present are the only available source of sex ratio data for north Pacific albacore because sex ratio data are not normally collected by commercial fisheries. Although sample sizes of sexed individuals ranged from about 10 to 300 per year, they show that the males reach larger sizes than females (Figure 3.7), that the sex ratio of males to females increases as latitude decreases, and that most of the large fish were sample south of 25°N (Table 3.4). These findings are significant because they are consistent with commercial fishing data (large fish are only observed in southern areas) and because it may mean that catches in F16 and F17 are primarily large male albacore.

4.0 MODEL DESCRIPTION

The 2014 stock assessment of north Pacific albacore tuna was conducted using the Stock Synthesis (SS) modeling platform (Methot 2000, Methot and Wetzel 2013). A sex-specific, length-based, age-structured, forward-simulating, fully-integrated, statistical model was developed for the stock assessment. The specification of the base case model for north Pacific albacore followed several steps. First, the spatial and temporal extent of fisheries in the assessment were defined based on analyses of the biology and historical fishing operations of albacore fisheries (ALBWG 2013a, ALBWG 2013b). Second, the data sources and inputs for these fisheries in the model, including total catch, indices of relative abundance, and size compositions were identified, collated and reviewed for completeness, trends, and outliers or unusual behaviour. Third, important biological parameters (e.g., growth, stock-recruitment relationship) were obtained from previous studies after review by the ALBWG and included in the model as fixed parameters, or estimated within the assessment model (Table 4.1). Based on these inputs, preliminary models were developed and iteratively refined through an analysis of model fits (e.g., total and component negative log-likelihoods) and diagnostic outputs (e.g., R_0 profiles, Pearson residuals) (ALBWG 2014 –

Attachment 4), resulting in a base case model, described below, with several differences from the base case model in the 2011 stock assessment (ALBWG 2011), including 3 years of additional data, new fisheries definitions, and sex-specific growth curves.

4.1 Stock Synthesis

Stock Synthesis is a highly flexible, statistical age-structured population modeling platform that can incorporate multiple data types and account for a variety of biological, fishery, and environmental processes (Methot and Wetzel 2013). Importantly for this assessment, SS can model sex-specific growth but fit to non-sex-specific observations. Although SS was initially developed and used in domestic stock assessments, particularly groundfish assessments, on the west coast of the United States, its use has spread to stock assessments of large pelagic fish like tunas and sharks because of the flexibility it provides for using multiple data types and processes.

The SS platform consists of three subcomponents: 1) a population dynamics subcomponent that simulates the assessed population (i.e., population numbers and biomass at age) using processes such as natural and fishing mortality, and the stock-recruitment relationship; 2) an observational subcomponent that relates the modeled population dynamics to observed quantities including abundance indices and size composition data; and 3) a statistical subcomponent that quantifies the fit of the observations to the simulated population using maximum likelihood methods. The 2014 north Pacific albacore assessment model was implemented using SS version 3.24f (Methot 2000; Methot and Wetzel 2013; http://nft.nefsc.noaa.gov/Stock_Synthesis_3.htm).

4.2 Biological and Demographic Assumptions

4.2.1 Maximum Age

The maximum age bin in the model was 15 years based on the maximum observed age (Wells et al. 2013). This bin served as the accumulator for all older ages. To avoid potential biases associated with the approximation of dynamics in the accumulator age, the maximum longevity was set at an age sufficient to result in near zero fish in this age bin (≈ 1 percent of an unfisher cohort).

4.2.2 Growth

Sex-specific growth curves were used in this model because recent studies have found that north Pacific albacore tuna exhibit sex-specific growth, with male albacore growing to a larger size (Chen et al. 2012; Xu et al. 2014a) (see Section 2.1.3). Candidate sex-specific von Bertalanffy growth models from two recent studies: 1) Chen et al. (2012); and 2) Xu et al. (2014a), were considered for this assessment. Chen et al. (2012) primarily aged otolith samples from the northwestern Pacific while Xu et al. (2014a) included age-at-length data from Chen et al. (2012) as well as Wells et al. (2013), which primarily used otolith samples from the central and eastern Pacific.

These two growth models (Table 4.2) were consistent with different growth hypotheses that explain the observation that the largest-sized albacore tend to be found in areas closer to the equator but very small numbers of albacore are caught in these areas. The Chen et al. (2012) growth model had lower L_{inf} for both sexes relative to the Xu et al. (2014a) growth model. This was consistent with the hypothesis (Growth Hypothesis 1) that the vast majority of adult north Pacific albacore were in subtropical and temperate areas of the northwestern Pacific, where albacore grew to a smaller L_{inf} than the small number of albacore in areas closer to the equator. In contrast, the larger L_{inf} of the Xu et al. (2014a) growth model is consistent with the hypothesis (Growth Hypothesis 2) that north Pacific albacore share a common sex-specific growth model with larger L_{inf} but larger albacore tend to move to the areas nearer the equator and are available to fisheries in those areas. Current biological information on north Pacific albacore does not strongly support

either hypothesis so preliminary models consistent with each hypothesis were developed and compared by the ALBWG.

The base case assessment model was based on Growth Hypothesis 2 and the Xu et al. (2014a) sex-specific growth model because the ALBWG concluded based on the preliminary model results that Growth Hypothesis 2 was better able to explain all of the available size composition data than Growth Hypothesis 1 (using the Chen et al. (2012) growth model). Using Growth Hypothesis 2, the base case model fits all of the size composition data, including fisheries with non-negligible proportions of fish >120 cm (e.g., F16-20). In contrast, using Growth Hypothesis 1 required the assumption that the selectivity of fisheries F16-20 were identical to F8 and so the size composition data from these fisheries were not fitted in the preliminary model. Since Growth Hypothesis 1 based on the Chen et al. (2012) growth model provides an alternate view of growth and productivity in the north Pacific albacore stock, it was used in a sensitivity run (Section 5.6.3) rather than the base case model.

A von Bertalanffy growth function, as parameterized by Schnute (1981), was used to model the relationship between fork length (cm) and age for north Pacific albacore:

$$L_2 = L_{inf} + (L_1 - L_{inf})e^{-K(A_2 - A_1)}$$

where L_1 and L_2 are the sizes associated with ages, A_1 and A_2 , respectively, L_{inf} is the asymptotic length, and K is the growth coefficient.

In this assessment, L_1 was fixed at 43.504 and 47.563 cm for females and males at age 1, respectively (Table 4.2). The L_{inf} and K parameters were also fixed at sex-specific values from Xu et al. (2014a) (L_{inf} - female: 106.570 cm, male: 119.150 cm; K - female: 0.2976 y^{-1} , male: 0.2077 y^{-1}) (Figure 4.1). The coefficients of variation (CVs) of size-at-age at L_1 (CV_1) and L_{inf} (CV_2) were fixed at 0.06 and 0.04 for both female and male albacore in the base case model, based on estimates of these CVs during preliminary runs. The CV_1 parameter was well estimated in the preliminary runs because of the clear modal structure in juvenile size composition data and the model results were not highly sensitive to this parameter. However, the CV_2 parameter was highly influential in the preliminary model results because of an interaction with the L_{inf} parameter. An analysis of conditional age-at-length data found that the variability of size-at-age for older albacore was similar to juvenile albacore and that the CV was approximately 0.04 (Xu et al. 2014a). Sensitivity analyses of the CV_2 parameter and alternative growth models were performed (Table 4.2 and Section 5.6).

4.2.3 Weight-at-Length

Non sex-specific weight-length relationships are used to convert catch-at-length to weight-at-length data (Figure 4.2). A previous study (Watanabe et al. 2006) reported that there were seasonal differences in the relationship between weight (kg) and fork length (cm) of north Pacific albacore. These non sex-specific seasonal weight-at-length relationships were used in this assessment (Table 4.1) and the 2011 assessment (ALBWG 2011) because there are no studies documenting sex-specific differences in the weight-length relationships of north Pacific albacore at present.

4.2.4 Sex Specificity

A sex-specific (2 sex) model was used for this assessment because of known differences in growth of female and male albacore (Chen et al. 2012; Xu et al. 2014a; Section 2.1.3). In addition, males predominate in longline catches of mature albacore sampled scientifically while juveniles <85 cm generally have a sex ratio of 1:1 (Otsu and Uchida 1959; Otsu and Sumida 1968; Foreman 1980). However, there are currently no data on the sex of individual fish caught by commercial fisheries.

As described above, sex-specific growth curves were used in the base case model. However, the base case model did not include sex-specific natural mortality nor selectivity, and sex ratio at birth was assumed to be 1:1.

4.2.5 Natural Mortality

Natural mortality (M) is a difficult parameter to estimate in an assessment model and it was not attempted during this assessment. M was fixed at 0.3 yr^{-1} for both sexes and all ages, i.e., there is no variation with age (Table 4.1). This assumption was used in previous assessments of north Pacific albacore (e.g., ALBWG 2007, 2011) and was taken from north Atlantic albacore assessments (e.g., ICCAT 2010) since productivities of the north Atlantic and north Pacific albacore stocks were similar based on previous assessment results. M cannot be reliably estimated from north Pacific albacore tagging data because tag return rates are low, especially in the western Pacific Ocean (Bertignac et al. 1999), and estimates of M are positively correlated with tag return rates (see Ichinokawa et al. 2008). Although males predominated in longline catches of mature albacore in historical scientific studies (Otsu and Uchida 1959; Otsu and Sumida 1968; Foreman 1980), possibly indicating a higher M for mature females, it is currently unknown whether albacore experience sex-specific rates of M or if sex-specific growth alone can explain this difference. Sensitivity analyses of different M values were conducted (Section 5.6).

4.2.6 Movement

The current stock assessment does not have explicit spatial structure and does not explicitly model the movements of north Pacific albacore. North Pacific albacore are known to exhibit seasonal and ontogenetic movements (e.g., Ichinokawa et al. 2008; Childers et al. 2011), but it is not currently feasible to develop a spatially explicit assessment model due to the lack of well designed, and consistent tagging data. Instead, time-varying selectivity patterns for fisheries were used as a proxy for spatial structure, which helps to compensate for potential biases caused by the lack of explicit spatial structure in the assessment model (Hurtado-Ferro et al. 2014). The collection and pre-processing of fishery data in this assessment are area (i.e., country-gear) specific, especially the Japanese longline fishery, and therefore contain spatial inference (Section 3.3).

4.2.7 Stock Structure

The current stock assessment assumes a single stock of albacore in the north Pacific Ocean from the equator to 55°N latitude and between 120°E and 100°W longitude (Figure 3.2). This assumption is supported by evidence from genetic, tagging, and seasonal fishing pattern studies (Suzuki et al. 1977; Chow and Ushima 1995; Takagi et al. 2001; Ichinokawa et al. 2008).

4.2.8 Recruitment and Reproduction

North Pacific albacore are assumed to have one spawning and recruitment period in the second quarter of the year (Q2) based on recent histological assessments of gonadal status and maturity reported by Chen et al. (2010). In addition, Ueyanagi (1957) estimated that 50% of the albacore at age-5 were mature and that all fish age-6 and older were mature (Figure 4.3). This maturity ogive was used in this assessment because no new information supporting a change in this assumption is available. This maturity ogive was also used in the previous two assessments in 2006 and 2011 (ALBWG 2011).

A standard Beverton and Holt stock recruitment model was used in this assessment. The expected annual recruitment was the function of spawning biomass with steepness (h), virgin recruitment (R_0), and unfished equilibrium spawning biomass (SSB_0) corresponding to R_0 and were assumed to follow a lognormal distribution with standard deviation σ_R (Methot 2012; Methot and Wetzel

2013). Annual recruitment deviations were estimated based on the information available in the data and the central tendency that penalizes the log (recruitment) deviations for deviating from zero. The log-bias adjustment factor was used to assure that the estimated log-normally distributed recruitments are mean unbiased (Methot and Taylor 2011)

Recruitment variability (σ_R) was fixed and rescaled in the final model to match the expected variability of 0.5. The log of R_0 , annual recruitment deviates, and the offset for the initial recruitment relative to virgin recruitment, R_1 , were estimated in the base case model. The choice of estimating years with information on recruitment was based on a preliminary model run with all recruitment deviations estimated (1966-2012). The first few years of size composition data often contain some information on recruitment from early cohorts before 1966 and the variability of recruitment deviations often increases as the information content decreases the further back in time prior to starting year examined (Methot and Taylor 2011). The number of years for which recruitments may be observed for the early cohorts were selected and the initial recruitment deviances were estimated in the model. Ten annual deviations were estimated prior to the start of the model in 1966 (i.e., 1956-1965). The 10-year period was chosen because early model runs showed little information on deviates more than 10 years prior to the beginning of the data. Bias adjustment was used to account for the reduction in information content from the data on recruitment deviations during the early and late periods. This adjustment mostly affects the estimation of uncertainty not the population trajectory.

Steepness of the stock-recruitment relationship (h) was defined as the fraction of recruitment from a virgin population (R_0) when the spawning stock biomass is 20 percent of its virgin level (SSB_0). The steepness parameter, h , is usually poorly estimated because there is little information in the data about this quantity (Magnusson and Hilborn 2007; Conn et al. 2010; Lee et al. 2012). However, Lee et al. (2012) concluded that if the model is correctly specified, then steepness is estimable for relatively low productivity stocks with good contrast in spawning stock biomass. Estimating h within the assessment model for north Pacific albacore is likely to be imprecise and biased because contrast in the spawning biomass over the assessment period is relatively poor. Two independent estimates of steepness for north Pacific albacore (Brodziak et al. 2011; Iwata et al. 2011), based on the life history approach of Mangel et al. (2010), reported values of h ranging from 0.84 to 0.95. Therefore, the ALBWG assumed that the steepness value is 0.9 in this assessment, and performed sensitivity analyses within a plausible range of steepness values. Nevertheless, the ALBWG notes that these steepness estimates are subject to considerable uncertainty and further work is needed to evaluate steepness estimates.

4.2.9 Initial Conditions

A model must assume something about the period prior to the start of the main population dynamics period. Typically, two approaches are used to achieve this assumption. The first approach starts the model as far back as necessary to satisfy the notion that the period prior to the estimation of dynamics was in an unfished or near unfished state. However, this approach is not viable for the north Pacific albacore stock because it has been heavily fished since at least the early 20th century but good catch records from that period are not currently available. Instead, a second approach was used for north Pacific albacore, which is to estimate (where possible) initial conditions assuming equilibrium catch. The equilibrium catch is the catch taken from a fish stock when it is in equilibrium with removals and natural mortality balanced by stable recruitment and growth. The initial fishing mortality rates in the assessment model that remove these equilibrium catches were estimated to allow the model to start at an appropriate depletion level. Initial fishing mortality rates were estimated for the F1 (Japan pole-and-line) and F8 (Japan longline) fisheries, which are responsible for the majority of the historical catches of juvenile and adult albacore, respectively, but

the initial fishing mortality rates were not fit to these historical catches prior to 1966. This approach allowed the model to start in 1966 at a depletion level that was consistent with the abundance indices and size composition data without being overly constrained by relatively poorly known catches in the early years. In addition, the model included estimation of 10 recruitment deviations prior to 1966 to develop a non-equilibrium age structure at the start of the model time frame.

4.3 Fishery Dynamics

4.3.1 Selectivity

The base case model has a sex-specific structure, with sex-specific growth curves. However, we assume that female and male albacore have identical size selectivity for each fishery because sex-specific size composition data are not available. Selectivity curves were fishery-specific and assumed to be a function of size, with the additional assumption that age-0 fish were not selected regardless of their size because age-0 albacore are rarely caught despite intensive fisheries targeting juvenile fish. Selectivity curves were estimated for all fisheries with representative size composition data while selectivity curves for fisheries without representative size composition data were assumed to be the same as fisheries with similar operating characteristics (season, area, gear) and estimated selectivity curves. If specific fisheries had changes in fishery operations or exhibited changes in size composition data consistent with changes in movement patterns, selectivity was allowed to vary with time to account for these changes. Highlights on the parameterization of the selectivity curves are briefly described below but more details can be found in Table 4.3.

Selectivity curves for all surface fisheries (F1, F2, and F7) were assumed to be dome-shaped and were modeled with double-normal selectivity. The double-normal selectivity curve was configured to use four parameters: 1) peak, which is the initial length at which albacore are fully selected; 2) width of the plateau at the top; 3) width of the ascending limb of the curve; and 4) width of the descending limb of the curve. If the estimated width of the plateau at the top was negligible and tended to hit the lower bounds, then that parameter was fixed to a small value.

Selectivity curves for the longline fisheries were assumed to be dome-shaped (F3, F4, F8, F21, F22, and F24) or logistic (F12, F16, F17, and F20), depending on the size of fish caught. Fisheries that caught relatively large proportions of fish >100 cm were assumed to be logistic and these fisheries were predominantly operating in areas nearer the equator (i.e., south of 20°N), where these large albacore tend to be most commonly caught. The dome-shaped selectivity curves for the longline fisheries were modeled as described above. The logistic selectivity curves were configured to use two parameters: 1) size at the inflection point; and 2) width for 95% selection.

The selectivity curves for longline fisheries lacking size composition data (F5, F6, F9, F10, F11, F13, F14, F15, F18, F19, and F23) were assumed to be the same as (i.e., mirrored to) closely related fisheries or fisheries operating in the same area (Table 4.3). For example, the selectivity of F5 and F6 were assumed to be the same as F3 and F4, respectively, because F5 and F6 were identical fisheries to F3 and F4 except that their catch units were in number of fish rather than biomass (t).

Selectivity curves for relative abundance indices were assumed to be the same as the fishery from which each respective index was derived. The selectivities for the S1 and S2 adult albacore indices were assumed to be the same as the F12 and F8 longline fisheries, respectively. The selectivities for the S3 and S4 juvenile albacore indices were similarly assumed to be the same as the F1 and F2 pole-and-line fisheries, respectively. A technical feature of the SS platform allowed the ALBWG to merge the S1 to S4 abundance index data into their respective fisheries in the base case model

because doing so substantially reduced computational time and is equivalent to mirroring these selectivities.

Selectivity curves were allowed to vary over time for fisheries exhibiting important changes in fishery operations or if large changes in fish availability during certain periods was reflected in changes in the size composition data (Table 4.3). For example, selectivity of the Japan pole-and-line fisheries (F1 and F2) varied between two periods (1966-1989 and 1990-2012) because an analysis of their fishery operations showed that their fishing operations were different during these two periods (Kiyofuji 2013). In another example, selectivity for F3 and F4 (Japan longline fisheries) varied between three periods (1966-1983, 1984-1993, and 1994-2012) because changes in the size composition during 1984-1993 were best explained by changes in the movements and availability of large albacore into the area. In this example, time-varying selectivity curves for F3 and F4 were used to model changes in albacore availability and to compensate for potential biases caused by the lack of explicit spatial structure in the assessment model (Hurtado-Ferro et al. 2014). Logistic-shaped selectivity is assumed for the middle period (1975-1992) of Japan longline fisheries F8 to F15 (20-55°N, 130°E-180°) due to the presence of very large fish in the size composition data while the first (1966-1974) and last (1993-2012) periods are modeled with dome-shaped selectivity. This middle period was divided into separate fisheries (F12-15) from the other periods (F8-11) because of the markedly different parameterization of selectivity during this period (Table 4.3).

4.3.2 Catchability

Catchability, q , was estimated (solved analytically) assuming that the survey indices were proportional to vulnerable biomass with a scaling factor of q . It was assumed that q was constant over time for each index.

4.4 Data Observation Models

The current assessment model fits three data components: 1) total catch, 2) relative abundance indices, and 3) size composition data. The observed total catches are assumed to be unbiased and relatively precise, and were fitted assuming a lognormal error distribution with standard error (SE) of 0.05. An unacceptably poor fit to catch occurred if a model removed <99% of the observed total catch from any fishery.

The relative abundance indices were assumed to have lognormally distributed errors with SE in log space, which is approximately equivalent to CV (SE/estimate) in natural space. The CVs of each candidate index were described in their respective papers (Section 3.5). However, the reported CVs for the abundance indices only capture observation errors within the standardization model and do not reflect process errors that are inherent in the link between the unobserved vulnerable population and observed abundance indices. The ALBWG initially assumed that the minimum average CV for any index was 0.2 and indices with average CV <0.2 were scaled to CV=0.2 by adding a constant while indices with CV >0.2 were left unmodified. Input CVs for all indices, including base case and sensitivity run indices are shown in Table 3.3. Preliminary model runs in which CV was estimated (ALBWG 2014) found that the average CV of the S4 index was higher than 0.2, so the average CV of the S4 index was set to 0.3 by using variance adjustment factors (Table 4.4). The effect of higher S4 index CV on model results was investigated using sensitivity runs.

The size composition data were assumed to have multinomial error distributions with the error variance determined by the effective sample size ($effN$). Size measurements of fish are usually not random samples of fish from the entire population, rather they are highly correlated within each set or trip (Pennington et al. 2002). The effective sample size is usually substantially lower than the actual number of fish measured because the variance within each set or trip is substantially lower

than the variance within a population. The initial effective sample size was set to the number of trips from which fish were measured to account for the lower variance within a trip relative to the population. Since many albacore fisheries do not record the number of trips, an analysis of the EPO surface (F7) and US deep-set longline (F20) was used to relate the number of fish or sets sampled to the number of trips. Based on this analysis, we assumed that 80 fish per trip were sampled for surface fisheries while 20 fish per trip and 7 sets per trip were sampled for longline fisheries. The minimum and maximum quarterly sample size was set to 5 and 150 respectively. Size composition records with <5 sample sizes were considered unrepresentative and removed while sample sizes >150 were set to 150. This large dynamic range of samples sizes allowed the ALBWG to preserve contrast in sample sizes between lightly and heavily sampled fisheries in the assessment model.

4.5 Data Weighting

Statistical stock assessment models fit a variety of data components, including abundance indices and size composition data. The results of these models can depend substantially on the relative weighting between different data components (Francis 2011). A statistical approach using the maximum likelihood estimates of variances or effective sample sizes to weight each data component by model fit (Deriso et al. 2007; Maunder 2011) tends to put too much weight on size composition data because numerous important processes such as variability in movements and selectivity are often not modeled or mis-specified. As a result, many assessments now use a subjective scheme to weight different components based on expert knowledge of the data sampling, fishery operations, and biology of the stock, in order to balance or prioritize information from various data components

Relative abundance indices were prioritized in this assessment based on the principle that relative abundance indices should be fitted well and that other data components such as size composition data should not induce poor fits to the abundance indices because abundance indices are a direct measure of population trends and scale (Francis 2011). We adopted a multi-step process to reduce the relative weighting of the size composition data because: 1) preliminary model runs with size composition data at natural weights resulted in very poor fits to the adult abundance indices (S1 and S2); 2) the size composition data were not raised to the catch and may, therefore, have substantial observation errors; and 3) variability in movements and availability were not explicitly modeled but rather were captured using time-blocks of selectivity as proxies for these processes. In the first step, sample sizes of all size composition data components (ranging from 5 to 150) were reduced using a variance adjustment multiplier (0.03) to improve model fit to the adult abundance indices. Preliminary model runs showed that a 0.03 multiplier on the sample sizes was required to match observed adult abundance trends and match observed errors in model fits to adult indices to expected errors in these fits (root-mean-square-error of <0.2). Subsequently, the Pearson residuals of the model fits to each size composition data component were examined to determine if the scale of the residuals matched expectations. Sample size multipliers of each size component were increased in steps (0.045 or 0.06 multipliers) if the scale of the Pearson residuals of a data component was less smaller than expected (i.e., approximately 95% of the residuals should be within ± 2 standard deviations). Details on the weightings of specific data components are in Table 4.4. The effect of these data weightings on model results was investigated using sensitivity runs.

4.6 Model Diagnostics

Model diagnostics were used to assess issues associated with convergence, structure, parameter mis-specification, and data conflicts in the 2014 base case model. The following diagnostic tools were employed in this assessment: 1) model convergence tests, 2) R_0 likelihood profiles, 3) residual analysis, and 4) retrospective analysis.

4.6.1 Model Convergence

Convergence to the global minima was examined by changing initial parameter values and the order of phases used in the optimization procedure. Particular attention was placed on the initial value and estimation phase of parameters, such as R_0 , that influence population scale because these changes force the model to search over a vastly expanded portion of the likelihood surface. In addition, all initial parameter values were randomly jittered by sampling from a uniform distribution centered at input parameter values with upper and lower bounds of $\pm 10\%$. The optimized likelihood and R_0 values were examined from 50 such model runs to ensure that these model runs did not find a solution with better likelihoods.

4.6.2 Likelihood Profile on Virgin Recruitment (R_0)

Likelihood profiling over virgin recruitment (R_0) was used to examine the influence of each data component on the overall population scale (Lee et al. 2014). The un-fished level of recruitment (R_0) is a global scaling parameter in an SS-based model because it is proportional to un-fished biomass. This process is used to assess whether the relative data weightings are appropriate and/or whether the model is mis-specified. The likelihood profile consisted of running a series of models with the $\ln(R_0)$ parameter fixed at a range of values above and below that estimated within the model, and examining the likelihoods of the various data components.

4.6.3 Residual Analysis

Model fit residuals (i.e., differences between observed data and expected values) were examined to evaluate model fit and performance. The residuals were first visually examined for patterns. The variances of residuals were also compared to evaluate the statistical assumptions of the observation model. If the variance of the residuals differs substantially from the assumed variance, then the relative data weightings likely were not appropriate. However, the lack of residual patterns does not ensure that the model is not mis-specified because parameter estimates can change to compensate for the mis-specification (Maunder and Punt 2013).

4.6.4 Retrospective Analysis

Retrospective analysis is used to identify systemic inconsistencies in population estimates given increasing or decreasing data periods. In this assessment, we perform a within-model retrospective analysis by systematically removing the terminal year of data from successive models (1 to 5 years), while maintaining the same model structure between models.

4.7 Sensitivity to Model Assumptions

A series of sensitivity runs were performed to examine the effects of plausible alternative model assumptions on the assessment results, and to aid in the identification of the major axes of uncertainty in this assessment. The sensitivity analyses conducted in this assessment (Table 4.5) can be categorized into two main themes: 1) biology (e.g., growth, natural mortality, steepness) ; and 2) data (e.g., data weighting, start year, alternative indices). For each sensitivity run, female spawning stock biomass (SSB), fishing intensity (1-SPR) trajectories, and where appropriate, model fits to the data, were compared.

4.8 Fishery Impact Analysis

The impact of the surface and longline fisheries on SSB was evaluated. The fishery impact analysis was conducted using the parameterization and assumptions of the base case model and dropping the annual catches (1966-2012) and initial equilibrium fishing mortality for longline and surface fisheries (Table 3.1) from the SS base case data file one-by-one and calculating the SSB time series

for each scenario. The magnitude of differences in the simulated SSB trajectories with and without fishing indicates the impact of the major fishery types on the spawning biomass of north Pacific albacore. Due to the model structure, the Japan, Korea, and Taiwan gillnet, Japan miscellaneous, and EPO miscellaneous fisheries are included as part of the surface fisheries.

4.9 Future Projections

Stock projections were used to assess the impact of current F on future harvest and stock status. In addition, the probability that current F will cause future SSB to fall below a threshold defined as the average of the ten historically lowest SSB estimates (SSB-ATHL) over a 25-yr projection period was estimated (see Ichinokawa 2011a). $F_{SSB-ATHL}$ is the interim biological reference point for north Pacific albacore adopted by the Northern Committee of the WCPFC (Northern Committee 2008) and is defined as the fishing mortality that results in future SSB, falling below SSB-ATHL in at least one year of a 25 year projection period with a 50% probability.

The stochastic future projections are based on an age-structured population dynamics model identical to SS base case model in principle, but implemented in R with coding that was used in the 2011 stock assessment of north Pacific albacore tuna (ALBWG 2011). Each projection is based on 100 bootstrap replicates to estimate parameter uncertainty followed by 10 stochastic simulations of future trends. Detailed algorithms for conducting the projections with options for future scenarios, and reference points, including $F_{SSB-ATHL}$, are described in Ichinokawa (2011b) (<http://cse.fra.affrc.go.jp/ichimomo/>).

Future recruitment was based on random resampling, with replacement, of historical recruitment for three periods: (1) low recruitment (29.1×10^6 recruits), 1983-1989, (2) average recruitment (42.8×10^6 recruits), 1966-2010, and high recruitment (54.8×10^6 recruits), 1966-1975. Projections started in 2011 and continued through 2041 under three levels of fishing mortality (constant $F_{2010-2012}$, constant $F_{2002-2004}$, constant catch averaged for 2010-2012, = 76,445 t) and the three levels of recruitment defined above. Projections with $F_{2002-2004}$ were conducted because 2002-2004 is the reference period for north Pacific albacore CMMs adopted by WCPFC and IATTC. The constant catch scenario was conducted using half the catches, assuming the sex ratio in catches is 1:1.

5.0 STOCK ASSESSMENT MODELLING RESULTS

5.1 Model Convergence

All estimated parameters in the base case model were within the set bounds and the final gradient of the model was $6.00E-6$, which indicated that the model had converged onto a local or global minimum. Based on the results from 50 model runs with different phasing and initial values, the base case model likely converged to a global minimum (i.e., there is no evidence of a lack of convergence to a global minimum) (Fig. 5.1). Total negative log-likelihood from the model run using the phasing and initial parameters from the base case model was the lowest (best) among these runs, and 22 out of 50 model runs also obtained the same negative log-likelihood. In addition, the estimated virgin recruitment in log-scale [$\ln(R_0)$] were similar from runs with total negative log-likelihoods similar to the base case model.

5.2 Model Diagnostics

5.2.1 Likelihood Profiles on Virgin Recruitment (R_0)

Results of the likelihood profiling on virgin recruitment, R_0 , for the abundance indices and size composition data components of the model are shown in Tables 5.1 and 5.2. Changes in the

likelihood of each data component are a measure of how informative that data component is to the overall estimated population scale.

Ideally, catch and relative abundance indices should be the primary sources of information on the population scale in a model (Lee et al. 2014). Since changes in log-likelihoods are small over the range of R_0 examined, the abundance indices in the base case model, even when fully weighted, do not appear to provide much information on population scale (Table 5.1). However, the maximum likelihood estimate of R_0 is approximately 10.77 and is consistent with the likely range of R_0 established by the abundance indices (Table 5.1). Based on these findings, the ALBWG concludes that changes in stock abundance over the assessment period are more closely related to changes in recruitment than fishing mortality since the abundance indices are not informative with respect to population scale in the base case assessment model.

The next most important source of information on scale in the model following the abundance indices is the size composition data for fisheries with logistic selectivity (Lee et al. 2014). In this assessment, the most important size composition data components were expected to be fisheries F12, F16, and F20, which all have logistic selectivity. In addition, examining the influence of F8, which has the largest adult catches from longline fisheries, is also important. The R_0 likelihood profiles for F12, F16 and F20 also show that size composition data from these fisheries do not provide substantial amounts of information on population scale and that $\ln(R_0)$ is likely within the range of 10.4 to 11.0, which is also corroborated by the F8 profile (Table 5.2). Size composition data from fishery F22, which has dome-shaped selectivity and relatively small catch, were found to be the largest influence on R_0 , when, in principle, they should not have a large influence on the R_0 . This finding may point to the need to re-examine this fishery to determine whether more flexibility in its selectivity processes is required or the weighting on this dataset should be reduced further than in the base case model. However, because the estimated R_0 in the base case model was found to be within the uncertainty range expected upon examination of the size composition data components with logistic selectivity, the ALBWG chose not to reconsider the estimation of selectivity of this fishery.

Overall, the R_0 likelihood profile confirm that there is substantial uncertainty in the estimate of population scale of this assessment, which is reflected in the uncertainty in biomass estimates. Nevertheless, the R_0 likelihood profile also show that the $\ln(R_0)$ estimate in the base case model is consistent with all the data components that the ALBWG believes to be important for defining population scale in the assessment model.

5.2.2 Residual Analysis of Abundance Indices

The base case model fit the adult (S1 and S2) abundance indices well (Figure 5.2 and Table 5.3). It was important that the root-mean-squared-error (RMSE) between observed and predicted abundance indices for S1 and S2 were <0.2 , which was the input CV for these indices, because these were the primary indices that provided information on the spawning stock biomass trends.

The base case model fits to the juvenile (S3 and S4) abundance indices were poorer than the adult indices (Figure 5.2 and Table 5.3) but were still considered to be consistent with the model input CVs. The RMSE for S3 was 0.242, which was approximately the mean input CV of 0.25 for the index. In contrast, the RMSE for S4 was 0.385, which was poorer than the sum of the mean input CV and variance adjustment (0.30). The variance adjustment on S4 was not increased to match the RMSE because the ALBWG chose to maintain a reasonably good fit as S4 is the terminal index for juvenile albacore, while acknowledging that the expected fits to this index is poorer.

5.2.3 Residual Analysis of Size Composition Data

Base case model fits to the size composition data were reasonably good. Overall, the model predicted size compositions matched the observations (Figure 5.3). Examination of the input sample size (input N) and model estimated effective sample size ($effN$) also show reasonably good model fits (Table 5.4). A higher $effN$ indicates better model fit, with a mean $effN > 30$ indicating good overall model fit. In addition, $effN$ to input N ratios were all >1 , which indicates that the base case input N did not assume less error than is evident in the model fits.

Pearson residual plots of the model fit to the size composition data did not reveal substantial patterns in residuals (Figure 5.4). Where patterns are evident visually, the scale of the residuals was relatively small, mostly lying within ± 2 standard deviations, partly as a result of the downweighting of the size composition data (Section 4.5).

Although the overall model fits to the size composition data were reasonably good, the largest misfits occurred for fisheries that predominantly caught juvenile albacore (e.g., F1, F2, F3, F7, F21, and F22), especially F1 and F2. The size composition data for F1 and F2 were highly variable, both seasonally and inter-annually, which may be due to changing fishery locations or migration patterns. Juvenile albacore exhibit extensive movement patterns (Ichinokawa et al. 2008, Childers et al. 2011), which will lead to variable selectivity in the base case model because selectivity was used as a proxy for movement (Hurtado-Ferro et al. 2014). In addition, the size composition data of most fisheries were not raised to the catch, which may lead to unrepresentative composition data if the sampling programs were not adequately randomized. However, the potential effects of these size composition misfits on model outputs were mitigated by the downweighting applied to the size composition data in the base case model. The relatively good fits to the size composition data from fisheries catching predominantly adult albacore (e.g., F8, F12, F16, F17, and F20) are evidence that the growth model and overall selectivity patterns used in the base case model adequately represent the data and are consistent with each other.

5.2.4 Retrospective Analysis

Retrospective analyses did not reveal any important pattern in the estimates of spawning biomass and fishing intensity (1-SPR) with the successive elimination of terminal year data (Figure 5.5).

5.3 Model Parameter Estimates

5.3.1 Selectivity

Most of the fisheries with estimated selectivity had dome-shaped selectivity, with logistic selectivity assumed for F12, F16, F17, and F20 only (Figure 5.6 and Table 4.3). This configuration is consistent with the growth hypothesis used in the base case model (Growth Hypothesis 2, Section 4.2.2), which assumes that the largest albacore tend to move south near the equator and are available to fisheries in these areas (i.e., F16, F17 and F20). The F12 fishery is the middle period (1975-1992) of the F8 fishery, when the fishery operated closer to the equator and encountered the large fish in the southern areas. During the middle period of F3 (1984-1993), the fishery fully selects for a wider size range of fish than the early (1966-1983) and late (1994-2012) periods, coinciding with the appearance of large-sized fish in F3 during that period (Figure 3.6), possibly due to increased movement of large-sized fish into the $10^{\circ} \times 10^{\circ}$ area defined for this fishery.

The peak and width of the ascending slope parameters for the fisheries with dome-shaped selectivity are typically precisely estimated while the width of the plateau and descending slope parameters have high uncertainty (Table 4.3). The differences in uncertainty of parameters in a double normal selectivity curve is expected because the width of the plateau and descending slope

parameters are correlated, which increases the uncertainty in these parameters. In contrast, both parameters in the logistic selectivities were relatively precisely estimated (Table 4.3).

5.3.2 Catchability

The catchability coefficient (q) was solved analytically in the base case model as a single value for each index (Table 5.3). Catchability was allowed to vary through time by separating the CPUE from a single fishery into multiple time-series based on an examination of the fishery operations of the fishery (Section 3.5).

5.3.3 Catch-at-Age

Juvenile albacore aged 2 and 3 are the largest component of the north Pacific albacore catch (Figure 5.7). This is likely due to the importance of surface fisheries (primarily troll, pole-and-line, but includes gillnet and other miscellaneous gears).

5.3.4 Sex Ratio

The sex ratio (males/females) estimated in the base case model show that sex ratio is approximately 1:1 until albacore reach age-10+, after which females becomes more common (Figure 5.8). This change in sex ratio is due to higher fishing mortality from longline fisheries on large fish, and the fact that males grow to larger sizes than females. However, the lack of sex ratio observations in the model makes it difficult to provide firm conclusions about the sex ratio estimates. In addition, a better understanding of the differences in natural mortality, if any, between male and female albacore would substantially improve these sex ratio estimates.

5.4 Stock Assessment Results

5.4.1 Biomass

The estimated female spawning biomass has fluctuated widely during the assessment period (1966-2012), ranging from a low of $97,569 \pm 30,203$ (\pm SD) mt in 1993 to a high of $204,401 \pm 73,551$ mt in 1971 (Table 5.5 and Figure 5.9). Importantly, there appear to be two periods when spawning biomass estimates were near historical lows: 1) 1989-1994 ($97,569 - 108,152$ mt); and 2) 2006-2012 ($98,562 - 110,655$ mt). However, the ALBWG notes that even during these periods with historically low spawning biomass, the north Pacific albacore stock was not in a heavily depleted state. Given that virgin spawning biomass (SSB_0) was estimated to be $307,830 \pm 44,956$ mt, the depletion ratios (SSB/SSB_0) during these periods were $0.32 - 0.35$ and $0.32 - 0.36$, respectively (Table 5.5 and Figure 5.9).

Uncertainties in the spawning biomass estimates were relatively large because the virgin recruitment parameter, which largely determines the population scale, was estimated to have had a relatively large uncertainty (Section 5.2.1). In addition, the uncertainties in the early biomass estimates are especially large because there is a lack of abundance index data and only limited size composition data during that period.

The total biomass estimates in the first quarter, which includes all age-1+ male and female albacore, have also fluctuated widely during the assessment period, ranging from a low of 544,126 mt in 1989 to a high of 1,041,570 mt in 1971 (Table 5.5 and Figure 5.9). In the recent period from 2004-2012, total biomass estimates have increased from 627,681 to 669,405 mt.

5.4.2 Recruitment

Estimated recruitment was generally consistent with the biology of the stock and the assumptions in the base case model. Recruitment estimates do not show a substantial trend with respect to spawning biomass (Figure 5.10), which is expected because albacore and other tunas have recruitment variability largely driven by environmental conditions, and a steepness of 0.9 was assumed in this assessment, based on prior analyses (Section 4.2.8). The estimated recruitments are consistent with the expected distribution of recruitment deviations ($\sigma_R = 0.5$), where only 2 estimates (1984 and 1987) were outside of the expected distribution (Figure 5.10).

The estimated recruitments have fluctuated widely during the assessment period (1966-2012), ranging from a low of 21.8 ± 7.4 million fish (\pm SD) in 1987 to a high of 64.6 ± 18.8 million fish in 1971 (Table 5.5 and Figure 5.11). All estimated recruitments during the assessment period were used for future projections except for 2011 and 2012, which were poorly estimated because very little information was available in the data from the terminal years to estimate recruitment. The average recruitment during 1966 – 2010 was 42.8 million fish, which was slightly below virgin recruitment (47.7 million fish). Importantly, there appears to a period of low recruitment during 1983 – 1989, when recruitment averaged 29.1 million recruits, and a period of high recruitment during 1966 – 1975, when recruitment averaged 54.8 million fish. As in other tuna species, the fluctuations in recruitment are strongly influenced by changes in environmental conditions as well as the stock-recruitment relationship.

Uncertainties in the recruitment estimates were large because uncertainty estimated for the virgin recruitment parameter, which largely determines the population scale, was relatively large (Section 5.2.1). In addition, the uncertainties in the early recruitment estimates are especially large because there is a lack of abundance index data and only limited size composition data for this early period.

5.4.3 Fishing Mortality

Fishing mortality-at-age (F-at-age) was estimated for female and male albacore in the base case model (Figure 5.12). The Fs on juveniles were higher than on adults for most of the assessment period but some periods exhibit higher Fs for adults. For example, the current F-at-age, $F_{2010-2012}$ (calculated as the geometric mean of the Fs from 2010 to 2012), is higher on adults than juveniles (Figure 5.13). In contrast, $F_{2002-2004}$ (reference years for current management measures) was higher on juveniles than adults (Figure 5.13). The F-at-age for adult females are also generally lower than adult males because female albacore do not grow as large as male albacore and the longline fisheries tend to have higher selectivity for large-sized albacore (Figure 5.6).

Female spawning potential ratio (SPR) is used to describe the fishing intensity on the stock. The SPR of a population is the ratio of female spawning biomass per recruit under fishing to the female spawning biomass per recruit under virgin conditions (Goodyear 1993). Therefore, $1-SPR$ is the reduction in female spawning biomass per recruit due to fishing and can be used to describe the fishing intensity on a fish stock. The fishing intensity on the north Pacific albacore stock has fluctuated between 0.4 and 0.7 during the assessment period (1966-2012) (Table 5.5, Figure 5.14).

5.5 Biological Reference Points

Kobe plots are presented in Figure 5.15 to illustrate the stock status of the north Pacific albacore stock in relation to several potential MSY-based and MSY-proxy biological reference points, based on the results of the base case model. The Kobe plots are presented for illustrative purposes because biological reference points have not been established for the north Pacific albacore stock, with the exception of the $F_{SSB-ATHL}$ interim reference point used by the Northern Committee of the

Western and Central Pacific Fisheries Commission (NC-WCPFC). $F_{SSB-ATHL}$ is the simulated fishing mortality (assuming identical selectivity to the base case model) on the north Pacific albacore stock, such that future SSB has a 50% probability of being higher than the average of the 10 historically lowest estimated SSBs (SSB-ATHL) threshold, over a 25 year projection period and assuming that recruitments are sampled from throughout the historical period. A Kobe plot based on F_{MED} is not presented because there is little contrast in the SSB time series so interpretation of this reference point would not be meaningful. Although the $F_{50\%}$ Kobe plot appears to show that overfishing has occurred over much of the 1966-2012 period, the ALBWG considers a conclusion of overfishing based on this reference point to be unreasonable given the model structure and assumptions employed in the assessment.

Based on an evaluation of the estimated current F ($F_{2010-2012}$) against various F -based reference points, including $F_{SSB-ATHL}$, the north Pacific albacore stock is not currently experiencing overfishing (Table 5.6). The point estimate (\pm SD) of maximum sustainable yield (MSY) is 105,571 \pm 14,759 t and the point estimate of spawning biomass to produce MSY (SSB_{MSY} , adult female biomass) is 49,680 \pm 6,739 t. Importantly, the SSB-ATHL threshold (i.e., the average of the ten historically lowest SSB estimates) is estimated to be 117,835 t, which is more than twice the SSB_{MSY} level. The ratio of $F_{2010-2012}/F_{MSY}$ is estimated to be 0.52 and the ratio of $F_{2010-2012}/F_{SSB-ATHL}$ is estimated to be 0.72. $F_{2010-2012}$ (current F) is below F_{MSY} and all MSY-proxy reference points except F_{MED} and $F_{50\%}$ (Table 1) and all ratios are lower than ratios estimated using $F_{2002-2004}$, consistent with the intent of previous ALBWG recommendations for conservation.

Although no biomass-based reference points have been developed for this stock, there is little evidence from this assessment that fishing has reduced SSB below reasonable candidate biomass based reference points (Figure 5.15), so the stock is likely not in an overfished condition at present.

The $F_{SSB-ATHL}$ reference point is the interim reference point adopted by the Northern Committee of the WCPFC (NC-WCPFC). The ALBWG notes three issues with the $F_{SSB-ATHL}$ interim reference point: (1) $F_{SSB-ATHL}$ is interpreted as the fishing mortality, F , that will lead to 50% of future SSB falling below the SSB-ATHL threshold level during a specified projection period and the probability of falling below the threshold was calculated as the proportion of future projection replicates in which estimated female SSB is below the SSB-ATHL threshold, (2) the time frame used to calculate the SSB-ATHL threshold was the model time frame (1966-2012), which because of changes in the spawning biomass trajectory means that there is a low SSB period in the 2000s, resulting in the use of SSBs estimated in 2007 through 2010 in the threshold calculation against which current F ($F_{2010-2012}$) is evaluated; and (3) $F_{SSB-ATHL}$ is extremely conservative if it is intended to be interpreted as a limit reference point for the stock since the estimated SSB-ATHL threshold (117,835 t) is more than twice the estimated biomass level necessary to support MSY (49,680 t), i.e., $SSB-ATHL > 2 \times SSB_{MSY}$.

5.6 Sensitivity to Model Assumptions

The following sensitivity analyses were performed to examine the effects of plausible alternative model assumptions on the assessment results, and help identify the major axes of uncertainty in this assessment (see Table 4.5 for details).

5.6.1 Sensitivity 01 – Growth Hypothesis 1

The growth model used in this assessment is a major axis of uncertainty (Section 4.4.2). Growth hypothesis 1 was considered to be a plausible alternative for this assessment but was not used in the base case model because it could not fit size composition data from longline fisheries operating in areas south of 20°N, nearer the equator. However, using growth hypothesis 1 results in a similar SSB trajectory and scale for most of the time period (Figure 5.16). The main difference between the

two models is in the SSB trends during the early part of the assessment, prior to start of the abundance index data. The estimated spawning depletions and fishing intensities (1-SPR) were also similar for both models.

5.6.2 Sensitivity 02 – CV of L_{inf}

The CV of L_{inf} is highly influential on the estimated scale of the north Pacific albacore stock (Figure 5.17). Increasing the CV of L_{inf} is similar to increasing the L_{inf} parameter by increasing the expected proportion of large fish and results in lower SSB, lower depletion ratio, and higher fishing intensity estimates. However, the model fits are better (lower total negative log-likelihoods) in the base case model than models runs with larger CVs, and the estimated CV of L_{inf} (0.0407) is similar to the assumed CV in the base case model (0.04). Based on these results, the ALBWG concludes that base case assumptions for the CV of L_{inf} are appropriate and consistent with other model components.

5.6.3 Sensitivity 03 – Non Sex-Specific Growth

The use of a non sex-specific (combined sex) growth model strongly influences the results of the stock assessment (Figure 5.18). The combined sex growth model has a smaller L_{inf} parameter (Table 4.2), which interacts with the CV of L_{inf} . Using a combined sex growth model results in higher SSB, higher depletion ratio, and lower fishing intensity, if the CV of L_{inf} is kept the same as the base case model (i.e., 1-sex 0.04 CV2 in Figure 5.17). However, the estimated CV of L_{inf} (0.062) in the combined sex growth model run was different from the base case model (0.04) because L_{inf} is smaller than used in the base case model. Similar to sensitivity 02, a larger CV of L_{inf} leads to lower SSB, lower depletion ratio, and higher fishing intensity estimates. The effect of the CV of L_{inf} was larger than the effect of using non sex-specific growth alone.

5.6.4 Sensitivity 04 – Stock-Recruitment Steepness Parameter

Results of the 2014 stock assessment were relatively insensitive to the assumed stock-recruitment steepness (h) (Figure 5.19). Changing the assumed steepness resulted in negligible differences in the SSB, depletion ratio, and fishing intensity estimates. Model fits were similar, although models with higher steepness values appeared to marginally improve the fit (i.e., total negative log-likelihoods for the four runs were: Base $h=0.9$, -327.493 ; $h=0.75$, -327.074 ; $h=0.85$, -327.359 ; and $h=0.95$, -327.617). This insensitivity to the value of h is likely due to the relatively undepleted state of the stock, which results in the stock being on the flatter part of the stock recruitment curve.

5.6.5 Sensitivity 05 – Natural Mortality

The assumed rate of natural mortality (M) was highly influential on the estimated scale of the 2014 north Pacific albacore stock assessment. A higher M results in higher SSB, higher depletion ratio, and lower fishing intensity estimates (Figure 5.20). Model fits were similar, although models with lower M values appeared to be slightly better fit (i.e., total negative log-likelihoods for the four runs were: Base $M=0.30$, -327.493 ; $M=0.25$, -327.667 ; $M=0.35$, -327.363 ; and $M=0.40$, -327.211).

5.6.6 Sensitivity 06 – Alternative Juvenile Abundance Indices

Changing the juvenile abundance indices to the Japan LLS indices (S6 and S7) had limited effects on model results (Figure 5.21). However, using the EPO surface indices (S8, S9 and S10) in place of the S3 and S4 indices in the base case model resulted in a moderate increase in the estimated scale of the stock and changed the SSB trends near the end of the assessment period slightly (Figure 5.20). In general, all the juvenile abundance indices (base case and alternatives) exhibited similar trends and fit the model well and it was expected that the model results were similar for these sensitivity runs.

5.6.7 Sensitivity 07 – CV of Juvenile Abundance Indices

Stock assessment results were relatively insensitive to the input CVs of the S3 and S4 juvenile abundance indices (Figure 5.22). There were only minimal changes to the estimated SSB time series, spawning depletion, and fishing intensity when the CVs of both indices were fixed at 0.2 or estimated. In addition, the model fits to the indices were relatively similar for both runs. Based on these results, the ALBWG concludes that base case assumptions for input CVs on the juvenile indices are appropriate and consistent with other model components.

5.6.8 Sensitivity 08 – Alternative Adult Abundance Indices

Changing the adult abundance indices had substantial effects on model results, with changes in both trend and scale (Figure 5.23). The alternative adult indices only begin in 1991 and 1995 for the US (S11) and Taiwan (S5) longline indices, respectively. Therefore the estimated SSB trends prior to 1990 are highly similar to the base case model because the same early adult indices were used, but diverge after 1990. All three models exhibit an increase in SSB during the 1990s followed by a decrease (albeit at different rates and to different levels). In addition, the alternative adult indices resulted in a slightly lower estimated population scale.

5.6.9 Sensitivity 09 – Start Year

Changing the start year of the model and hence including extra catch data (start year: 1952), or disregarding some early size composition data (start year: 1975) did not substantially change the model results (Figure 5.24). There were no available size composition data prior to the start of the base case model in 1966 so adding catch data alone from 1952 forward was not highly informative, especially since the stock has been heavily fished since the early 20th century.

5.6.10 Sensitivity 10 – Size Composition Weighting

Size composition data weighting is a major axis of uncertainty in this assessment. Changing the weighting of the size composition data components affected the trend and scale of the estimated population dynamics of the north Pacific albacore stock (Figure 5.25). Increasing the weighting of the size composition data led to higher and lower estimated recruitment deviations in the early and later periods of the assessment, respectively. These differences caused substantially higher estimated SSBs in the early period but the terminal SSBs, depletion ratios, and fishing intensities were only slightly different than estimated in the base case model.

Importantly, increasing the weighting of the size composition data substantially degraded the fit to the adult abundance index in the recent period (1993-2012) (Figure 5.26). The adult abundance index exhibits an increasing abundance trend during 1993-1999 but increasing the weight of the size composition data resulted in a predicted decreasing abundance trend instead. Since the most important aspect of the Francis (2011) approach that we employed is that relative abundance indices in the model should be well fit as they are a direct measure of population trends and scale, and that other data components such as size composition data should not be allowed to induce poor fits to the abundance indices, the ALBWG chose to downweight the size composition data components in the base case model. The results of this sensitivity analysis demonstrate that the weighting of the size composition data are consistent with the Francis (2011) approach.

5.7 Fishery Impact Analysis

Surface fisheries (primarily troll, and pole-and-line, but includes gillnet and other miscellaneous gears), which tend to catch juvenile fish, have generally had a larger impact on the north Pacific

albacore stock than longline fisheries, which tend to remove adult fish (Figure 5.27). However, the impact of longline fisheries has increased since the early 1990s.

5.8 Future Projections

Stochastic stock projections show projected female spawning stock biomass for each of the three harvest and three recruitment scenarios (Figures 5.28 and 5.29). The north Pacific albacore stock performs better under the constant $F_{2010-2012}$ harvest scenario than either the constant $F_{2002-2004}$ harvest scenario (Figure 5.28) or the constant catch scenario (Figure 5.29). Although a constant catch scenario was conducted, it is inconsistent with current and past management approaches and it may be unrealistic for this stock because catch is largely dependent on recruitment. Assuming average historical recruitment and fishing at a constant current F , median female SSB is expected to remain relatively stable between the 25th and median historical percentiles over both the short- and long-term, with a 13% probability that current SSB falls below the SSB-ATHL threshold during a 25-yr projection period (2011-2036). In contrast, if a low recruitment scenario is assumed, then median female SSB declines under both harvest scenarios below the 25th historical percentile and the probability that it falls below the SSB-ATHL threshold in the 25-yr projection period increases to 65%. The high recruitment scenario is more optimistic, with median SSB increasing above the historical median SSB and the estimated probability of breaching the SSB-ATHL threshold is correspondingly low at 3% (Figure 5.28). In the constant catch scenario (Figure 5.29), stock performance is consistent with expectations based on the recruitment used: it performs poorly in a low recruitment scenario relative to an average recruitment scenario whereas it performs well with a high recruitment scenario relative to average recruitment. However, the constant catch scenario (Figure 5.29) is inconsistent with current management approaches and it may be unrealistic for this stock because catches of north Pacific albacore are largely dependent on annual recruitment, given the dominance of surface fisheries harvesting juvenile north Pacific albacore.

6.0 STOCK STATUS

6.1 Current Status

The base case assessment model results were used to determine trends in population biomass, spawning biomass, recruitment, and fishing intensity of the north Pacific albacore tuna stock from 1966 through 2012. Estimates of total stock biomass (age-1 and older) and female spawning biomass (SSB) exhibit similar long term declines from the early 1970s to 1990 followed by a recovery through the 1990s and a leveling off in the 2000s (Figure 5.9). Female SSB was estimated to be approximately 110,101 t in 2012 and is more than twice as large as the spawning biomass estimated to produce MSY (SSB_{MSY}) of $49,680 \pm 6,739$ t. Stock depletion is estimated to be 35.8% of unfished SSB in the terminal year of the assessment (2012). Average historical recruitment is approximately 42.8×10^6 recruits annually, but there are periods of above and below average recruitment at the beginning of the assessment time frame followed by a 20-yr period of reduced variability around the average since the 1990s (Figure 5.11). Albacore recruitment, as in other tuna species, is probably influenced by both changes in environmental conditions and the stock-recruitment relationship. Estimated fishing intensity (1-SPR, female spawner per recruit relative to the unfished population) increased gradually until the early 2000s and then has declined until recent years (2010-2012; Figure 5.14). The estimated SPR in the terminal year of the assessment is 0.41, which corresponds to a relatively low exploitation level (i.e., $1-SPR = 0.59$). Current fishing mortality was defined as the average of estimates for 2010-2012 to account for uncertainty and fluctuation in estimates of recent years. Although current F -at-age on juvenile fish is lower in the base case model than in 2002-2004, F on adults (50% of age-5 and all fish age-6 and older) is higher on average than 2002-2004 (Figure 5.13). Juvenile albacore aged 2 and 3 are the largest

component of the catch as reflected by the larger impact of the surface fisheries relative to longline fisheries, which remove adult fish (Figure 5.27).

Stock status in relation to MSY-based and MSY proxy reference points is depicted in Kobe plots (Figure 5.15). The Kobe plots are presented for illustrative purposes only since biological reference points have not been established for the north Pacific albacore stock, with the exception of the $F_{SSB-ATHL}$ interim reference point used by the Northern Committee of the Western and Central Pacific Fisheries Commission (NC-WCPFC). $F_{SSB-ATHL}$ is defined as the F that will maintain SSB above the average of the ten historically lowest estimated SSB levels (SSB-ATHL) with a probability of 50% during a 25-yr projection period ((Northern Committee 2008). A Kobe plot using F_{MED} is not presented because interpretation would be hindered by the lack of contrast in the female SSB time series. When current F ($F_{2010-2012}$) is evaluated against various F -based reference points, current F is 28% below $F_{SSB-ATHL}$ and 48% below F_{MSY} and the ratios for most other candidate reference points, except F_{MED} and $F_{50\%}$, are below 1.0 (Table 5.6). In all cases, these ratios are lower than ratios estimated using $F_{2002-2004}$, which is the expected intent of previous ALBWG recommendations. Based on this analysis, the ALBWG concludes that the north Pacific albacore stock is not currently experiencing overfishing. Although no biomass-based reference points have been developed for this stock, there is little evidence from this assessment that fishing has reduced SSB below reasonable candidate biomass-based reference points (Figure 5.15), supporting the conclusion that the stock is likely not in an overfished condition at present given average historical recruitment.

6.2 Conservation Advice

Based on the results of the stock assessment, the north Pacific albacore stock is not experiencing overfishing and is probably not in an overfished condition. The current exploitation level ($F_{2010-2012}$) is estimated to be below that of $F_{2002-2004}$, which had led previously to the implementation of conservation and management measures (CMMs) for the north Pacific albacore stock in the eastern Pacific (IATTC Resolution C-05-02 supplemented by Resolution C-13-03) and the western and central Pacific Oceans (WCPFC CMM 2005-03). The probability that current F will lead to SSB falling below the SSB-ATHL threshold is well below 50% under both average and high historical recruitment scenarios, but rises to 65% if a low recruitment scenario is assumed. The ALBWG notes that there is no evidence that fishing has reduced SSB below thresholds associated with the majority of biomass-based reference points and that population dynamics in the north Pacific albacore stock are largely driven by recruitment, which is affected by both environmental changes and the stock-recruitment relationship. The ALBWG concludes that the north Pacific albacore stock is healthy and that current productivity is sufficient to sustain recent exploitation levels, assuming average historical recruitment continues.

7.0 KEY UNCERTAINTIES AND RESEARCH RECOMMENDATIONS

The ALBWG notes that the lack of sex-specific size data, the absence of updated estimates of important life history parameters (natural mortality, maturity), and the simplified treatment of the spatial structure of north Pacific albacore population dynamics are important sources of uncertainty in the assessment. The following recommendations were developed to improve the future iterations of the stock assessment model:

1. Size composition sampling should be raised to the catch (most of the size composition data in the current assessment were not raised) so that observation error and process error can be partitioned and dealt with appropriately;
2. All member countries are encouraged to collect sex ratio information from their fleets;

3. Changes in sex ratio and size by depth should be investigated because the WG suspects that there is either a depth-size-sex or a spatial area-sex-size effect that is important to the population dynamics of this stock;
4. Comprehensive sex-specific age and growth data are needed to improve understanding of growth in the north Pacific albacore stock; and
5. The application of cubic spline functions to estimate selectivity in the assessment model should be investigated. This approach was explored during the 2014 assessment workshop, but there was insufficient time to develop it satisfactorily.

8.0 LITERATURE CITED

- Albacore Working Group (ALBWG). 2014. Report of the Albacore Working Group Workshop, 14-28 April 2014, Southwest Fisheries Science Center, La Jolla, CA, USA. Annex 10. Report of the Fourteenth Meeting of the International Scientific Committee for Tuna and Tuna-like Species in the North Pacific Ocean. Plenary Session, 16-21 July 2014, Taipei, Taiwan.
- Albacore Working Group (ALBWG). 2013a. Report of the Albacore Working Group Workshop, 19-26 March 2013, Shanghai, China. Annex 07. Report of the Thirteenth Meeting of the International Scientific Committee for Tuna and Tuna-like Species in the North Pacific Ocean. Plenary Session, 17-22 July 2013, Busan, Republic of Korea.
- Albacore Working Group (ALBWG). 2013b. Report of the Albacore Working Group Workshop, 5-12 November 2013, Shimizu, Shizuoka, Japan. Annex 4. Report of the Fourteenth Meeting of the International Scientific Committee for Tuna and Tuna-like Species in the North Pacific Ocean. Plenary Session, 16-21 July 2014, Taipei, Taiwan.
- Albacore Working Group (ALBWG). 2011. Stock assessment of albacore tuna in the north Pacific Ocean in 2011. Report of the Albacore Working Group Stock Assessment Workshop, 4-11 June 2011, Shizuoka, Japan. Annex 9 in Report of the Eleventh Meeting of the International Scientific Committee for Tuna and Tuna-like Species in the North Pacific Ocean. Plenary Session, 20-25 July 2011, San Francisco, USA.
- Albacore Working Group (ALBWG). 2007. Report of the Albacore Working Group Workshop, November 28 – December 5, 2006, Shimizu, Japan. Annex 5. Report of the Seventh Meeting of the International Scientific Committee for Tuna and Tuna-like Species in the North Pacific Ocean, Plenary Session 25-30 July 2007, Busan, Korea.
- Bertignac, M., Hampton, J., and Coan, Jr., A.L. 1999. Estimates of exploitation rates for north Pacific albacore, *Thunnus alalunga*, from tagging data. *Fish. Bull.* 97: 421-433.
- Brodziak, J. Lee, H.-h., and Mangel, M. 2011. Probable values of stock-recruitment steepness for North Pacific albacore tuna. Working paper presented at the ISC Albacore Working Group Stock Assessment Workshop, 30 May-11 June 2011, Nat. Res. Inst. Far Seas Fish., Shimizu, Shizuoka, Japan. ISC/11/ALBWG/11: 9 p.
- Chen, D.G., 2011. CIE Review Report for Albacore Tuna Assessment. ISC/12/PLENARY/INFO /14 Review
- Chen, Y. 2011. CIE Independent Peer Review Report on Stock Assessment of albacore tuna, *Thunnus alalunga*, in the North Pacific Ocean. ISC/12/PLENARY/INFO /15.
- Chen, C.-Y., and Cheng, F.-C. 2013. Taiwanese albacore-targeting longline fisheries in the North Pacific Ocean, 1995-2011. Working paper was submitted to the ISC Albacore Working Group Intercessional Workshop, 05-12 November 2013, National Research Institute of Far Seas Fisheries, Shimizu, Shizuoka, Japan. ISC/13/ALBWG-03/01: 28p. Available at: http://isc.ac.affrc.go.jp/pdf/ALB/ISC13_ALB_2/ISC_13_ALBWG_03_01_Cheng&Chen_TWNLL.pdf
- Chen, K.-S., Crone, P.R., and Hsu, C.-C. 2010. Reproductive biology of albacore *Thunnus alalunga*. *J. Fish Biol.* 77: 119–136. doi:10.1111/j.1095-8649.2010.02662.x

- Chen, K.-S., Shimose, T., Tanabe, T., Chen, C.-Y., and Hsu, C.-C. 2012. Age and growth of albacore *Thunnus alalunga* in the North Pacific Ocean. *J. Fish Biol.* 80: 2328–2344. DOI: 10.1111/j.1095-8649.2012.03292.x
- Childers, J., Snyder, S., and Kohin, S. 2011. Migration and behavior of juvenile North Pacific albacore (*Thunnus alalunga*). *Fish. Oceanogr.* 20: 157–173. doi:10.1111/j.1365-2419.2011.00575.x
- Chow., S., and Ushiyama, H. 1995. Global population structure of albacore (*Thunnus alalunga*) inferred by RFLP analysis of the mitochondrial ATPase gene. *Mar. Biol.* 123: 39-45.
- Clemens, H.B. 1961. The migration, age, and growth of Pacific albacore (*Thunnus germon*), 1951-1958. *Calif. Dept. Fish Game Fish. Bull.* 115: 1-128.
- Conn, P.B., Williams, E.H., Shertzer, K.W., 2010. When can we reliably estimate the productivity of fish stocks? *Can. J. Fish. Aquat. Sci.* 67: 511–523.
- Cordue, P.L. 2011. Review of the 2011 North Pacific Ocean albacore tuna stock assessment. ISC/12/PLENARY/INFO/16
- Cosgrove, R., Arregui, I., Arrizabalaga, H., Goni, N., and Sheridan, M. 2014. New insights to behaviour of North Atlantic albacore tuna (*Thunnus alalunga*) observed with pop-up satellite archival tags. *Fish. Res.* 150: 89– 99.
- Deriso, R.B., Maunder, M.N., and Skalski, J.R. 2007. Variance estimation in integrated assessment models and its importance for hypothesis testing. *Can. J. Fish. Aquat. Sci.* 64: 187-197.
- Foreman, T.J. 1980. Synopsis of biological data on the albacore tuna, *Thunnus alalunga* (Bonnaterre, 1788), in the Pacific Ocean. *Inter-Am. Trop. Tuna Comm., Spec. Rep.* 2: 17-70.
- Francis, R.I.C.C. 2011. Data weighting in statistical fisheries stock assessment models. *Can. J. Fish. Aquat. Sci.* 68: 1124–1138. doi:10.1139/F2011-025
- Goodyear, C.P. 1993. Spawning stock biomass per recruit in fisheries management: foundation and current use, p. 67-81. In Smith, S.J., Hunt, J.J., and Rivard, D. [ed.] Risk evaluation and biological reference points for fisheries management. *Can. Spec. Publ. Fish. Aquat. Sci.* 120.
- Hurtado-Ferro, F., Punt, A.E., and Hill, K.T. 2014. Use of multiple selectivity patterns as a proxy for spatial structure. *Fish. Res.* 158: 102–115. doi: 10.1016/j.fishres.2013.10.001
- Ichinokawa, M. 2011a. Future projection for the North Pacific albacore, based on stock assessment by Stock Synthesis conducted in 2011. Working paper submitted to the ISC Albacore Working Group Stock Assessment Workshop, 30 May-11 June 2011, Nat. Res. Inst. Far Seas Fish., Shimizu, Shizuoka, Japan. ISC/11/ALBWG/14: 16p.
- Ichinokawa, M. 2011b. Operating manual and detailed algorithms for conducting stochastic future projections with R packages of 'ssfutur'. Nat. Res. Inst. Far Seas Fish., Shimizu, Shizuoka, Japan, 10 p. Available at: <http://cse.fra.affrc.go.jp/ichimomo/>
- Ichinokawa, M., Coan, Jr., A.L., and Takeuchi, Y. 2008. Transoceanic migration rates of young North Pacific albacore, *Thunnus alalunga*, from conventional tagging data. *Can. J. Fish. Aquat. Sci.* 65: 1681–1691.

Ijima, H., and Satoh, K. 2014. Abundance indices of albacore tuna for the Stock Synthesis III by Japanese longline fishery in the north west Pacific Ocean. Working paper presented at the ISC Albacore Working Group Workshop, 14-28 April 2014, Southwest Fisheries Science Center, La Jolla, USA. ISC/14/ALBWG/01: 10 p. Available at: http://isc.ac.affrc.go.jp/pdf/ALB/ISC14_ALB/ISC-14-ALBWG-01_JPNLLGLM.pdf

Ijima, H., Kiyofuji, H., and Okamoto, H. 2013. Abundance indices of albacore tuna by Japanese longline fishery in the north Pacific Ocean. Working paper submitted to the ISC Albacore Working Group Intercessional Workshop, 05-12 November 2013, National Research Institute of Far Seas Fisheries, Fisheries Research Agency, Shimizu, Shizuoka, Japan. ISC/13/ALBWG-3/02: 13 p. Available at: http://isc.ac.affrc.go.jp/pdf/ALB/ISC13_ALB_2/ISC_13_ALBWG_03_02_JPN_LL_CPUE.pdf

International Commission for the Conservation of Atlantic Tunas (ICCAT). 2010. Report of the 2009 ICCAT albacore stock assessment session. Collect. Vol. Sci. Pap. ICCAT, 65: 1113-1253.

Iwata, S., Sugimoto, H. and Takeuchi, Y. 2011. Calculation of the steepness for the North Pacific Albacore. Working paper submitted to the ISC Albacore Working Group Stock Assessment Workshop, 30 May-11 June 2011, Nat. Res. Inst. Far Seas Fish., Shimizu, Shizuoka, Japan. ISC/11/ALBWG/18: 6 p.

Kimura, S., Nakai, M., and Sugimoto, T. 1997. Migration of albacore, *Thunnus alalunga*, in the North Pacific Ocean in relation to large oceanic phenomena. Fish. Oceanogr. 6: 51-57.

Kiyofuji, H., and Uosaki, K. 2010. Revision of standardized CPUE for albacore caught by the Japanese pole and line fisheries in the northwestern North Pacific albacore. Working paper presented at the ISC Albacore Working Group Workshop, 12-19 October 2010, Southwest Fisheries Science Center, NOAA, La Jolla, USA. ISC/10-3/ALBWG/07, 11 p.

Kiyofuji, H. 2014. Update standardized CPUE for North Pacific albacore caught by the Japanese pole and line fishery. Working Paper submitted to the ISC Albacore Working Group Meeting, 14-28 April 2014, Southwest Fisheries Science Center, La Jolla, USA. ISC/14/ALBWG/06: 10 p. Available at: http://isc.ac.affrc.go.jp/pdf/ALB/ISC14_ALB/ISC-14-ALBWG-06_IPPLCPUE.pdf

Kiyofuji, H., and Ijima, H. 2013. Standardized CPUE for albacore caught by the Japanese pole and line fishery in the northwestern North Pacific Ocean. Working paper submitted to the ISC Albacore Working Group Workshop, 5-12 November 2013, National Research Institute of Far Seas Fisheries, Shimizu, Shizuoka, Japan. ISC/13/ALBWG-03/03: 18 p. Available at: http://isc.ac.affrc.go.jp/pdf/ALB/ISC13_ALB_2/ISC_13_ALBWG_03_03_JPN_PL_CPUE.pdf

Kiyofuji, H., Ijima, H. and Satoh, K. 2014. North Pacific albacore catch and size composition from the Japanese longline fishery. Working Paper submitted to the ISC Albacore Working Group Meeting, 14-28 April 2014, Southwest Fisheries Science Center, La Jolla, USA. ISC/14/ALBWG-01/07: 5 p.

Langley, A., Briand, K., Kirby, D.S., and Murtugudde, R. 2009. Influence of oceanographic variability on recruitment of yellowfin tuna (*Thunnus albacares*) in the western and central Pacific Ocean. Can. J. Fish. Aquat. Sci. 66: 1462-1477.

Lee, H.-H., Piner, K.R., Methot Jr., R.D., and Maunder, M.N. 2014. Use of likelihood profiling over a global scaling parameter to structure the population dynamics model: An example using blue marlin in the Pacific Ocean. Fish. Res. 158: 138-146. doi: 10.1016/j.fishres.2013.12.017

- Lee, H.-H., Maunder, M.N., Piner, K.R., and Methot, R.D. 2012. Can steepness of the stock–recruitment relationship be estimated in fishery stock assessment models? *Fish. Res.* 125– 126: 254– 261. doi:10.1016/j.fishres.2012.03.001
- Magnusson, A., and Hilborn, R., 2007. What makes fisheries data informative? *Fish Fish.* 8: 337–358.
- Maunder, M.N. 2011. Review and evaluation of likelihood functions for composition data in stock-assessment models: estimating the effective sample size. *Fish. Res.* 109: 311-319.
- Maunder, M.N., and Punt, A.E. 2013. A review of integrated analysis in fisheries stock assessment. *Fish. Res.* 142: 61-74.
- Mangel, M., Brodziak, J., and DiNardo, G. 2010. Reproductive ecology and scientific inference of steepness: a fundamental metric of population dynamics and strategic fisheries management. *Fish and Fisheries* 11: 89-104. doi: 10.1111/j.1467-2979.2009.00345.x
- Matsumoto, T., and Uosaki, K. 2011. Review of developing Japanese albacore fishery data to apply to stock synthesis model. Working paper submitted to the ISC Albacore Working Group Stock Assessment Workshop, 19-26 March 2011, National Research Institute of Far Sea Seas Fisheries, Shimizu, Shizuoka, Japan. ISC/11/ALBWG/08: 43 p. Available at: http://isc.ac.affrc.go.jp/reports/alb/alb_2011.html
- Method, R.D. 2000. Technical description of the Stock Synthesis assessment program. NOAA Tech. Memo. NMFS-NWFSC-43, 46 p.
- Methot Jr., R.D. 2012. User Manual for Stock Synthesis Model Version 3.24f Updated October 3, 2012. National Marine Fisheries Service, Northwest Fisheries Science Center, Seattle, WA, USA. Available at: <http://nft.nefsc.noaa.gov/SS3.html#About>
- Methot Jr., R.D., and Taylor, I.G. 2011. Adjusting for bias due to variability of estimated recruitments in fishery assessment models. *Can. J. Fish. Aquat. Sci.* 68: 1744-1760.
- Methot Jr., R.D., and Wetzel, C.R. 2013. Stock synthesis: a biological and statistical framework for fish stock assessment and fishery management. *Fish. Res.* 142: 86-99.
- Nishikawa, Y., Honma, M., Ueyanagi, S., and Kikawa, S. 1985. Average distribution of larvae of oceanic species of scrombroid fishes, 1956–1981. *Far Seas Fish. Res. Lab. S Series* 12.
- Northern Committee (NC). 2008. Fourth Regular Session, Tokyo, Japan, 9-11 September 2008, Summary Report. Western and Central Pacific Fisheries Commission, Kolonia, Pohnpei, Federated States of Micronesia, 41 p. <http://www.wcpfc.int/system/files/documents/meetings/northern-committee/4th-regular-session/summary-report/NC4%20Summary%20Report%20%28Preliminary%20version%29-edited%20clean.pdf>
- Otsu, T., and Sumida, R.F. 1968. Distribution, apparent abundance, and size composition of albacore (*Thunnus alalunga*) taken in the longline fishery based in American Samoa, 1954-65. *U.S. Fish Wild. Serv., Fish. Bull.* 67: 47-69.
- Otsu, T., and Uchida, R.N. 1959. Sexual maturity and spawning of albacore in the Pacific Ocean. *Fish. Bull.* 50(148): 287-305.

- Polovina, J.J., Howell, E., Kobayashi, D.R., and Seki, M.P. 2001. The transition zone chlorophyll front, a dynamic global feature defining migration and forage habitat for marine resources. *Prog. Oceanogr.* 49: 469–483.
- Ramon, D., and Bailey, K. 1996. Spawning seasonality of albacore, *Thunnus alalunga*, in the South Pacific Ocean. *Fish. Bull.* 94: 725-733.
- Satoh, K., Matsumoto, T., and Uosaki, K. 2014. Review of Japanese albacore catch data for the North Pacific albacore stock assessment in April 2014. Working paper submitted to the ISC Albacore Working Group Workshop, 14-18 April 2014, Southwest Fisheries Science Center, La Jolla, USA. ISC/14/ALBWG/01/2: 13 p. Available at: http://isc.ac.affrc.go.jp/pdf/ALB/ISC14_ALB/ISC-14-ALBWG-02_JPN_Catch_by_fishery.pdf
- Schnute, J. 1981. A versatile growth model with statistically stable parameters. *Can. J. Fish. Aquat. Sci.* 38: 1128-1140.
- Suzuki, Z., Warashina, Y., and Kishida, M. 1977. The comparison of catches by regular and deep tuna longline gears in the western and central equatorial Pacific. *Bull. Far Seas Fish. Res. Lab., Japan.* 15: 51-89.
- Takagi, M., Okamura, T., Chow, S., and Taniguchi, N. 2001. Preliminary study of albacore (*Thunnus alalunga*) stock differentiation inferred from microsatellite DNA analysis. *Fish. Bull.* 99: 697-701.
- Teo, S.L.H., Lee, H.-H., and Kohin, S. 2010. Time series associated with albacore fisheries based in the Northeast Pacific Ocean. Working paper submitted to the ISC Albacore Working Group Meeting, 12-19 October 2010, Southwest Fisheries Science Center, NOAA, La Jolla, California, USA. ISC/10/ALBWG-3/02: 17 p. Available at: http://isc.ac.affrc.go.jp/pdf/ALB/ISC10_ALB_3/ISC-10-ALBWG-3-WP02.pdf
- Ueyanagi, S. 1969. Observations on the distribution of tuna larvae in the Indo-Pacific Ocean with emphasis on the delineation of the spawning areas of albacore, *Thunnus alalunga*. *Bull. Far Seas Fish. Res. Lab.* 2: 177–256.
- Ueyanagi, S. 1957. Spawning of the albacore in the Western Pacific. *Rep. Nankai Reg. Fish. Res. Lab.* 6: 113-124.
- Uosaki, K., Kiyofuji, H., and Matsumoto, T. 2011. Review of Japanese albacore fisheries as of 2011. Working Paper submitted to the ISC Albacore Working Group Stock Assessment Workshop, 4-11 June 2011, National Research Institute of Far Sea Seas Fisheries, Shimizu, Japan. ISC/11/ALBWG/13: 16 p.
- Watanabe, H., Kubodera, T., Masuda, S. and Kawahara, S. 2004. Feeding habits of albacore *Thunnus alalunga* in the transition region of the central North Pacific. *Fish. Sci.* 70: 573–579.
- Watanabe, K., Uosaki, K., Kokubo, T., Crone, P. Coan, A., and Hsu, C.-C. 2006. Revised practical solutions of application issues of length-weight relationship for the North Pacific albacore with respect to the stock assessment. Working paper submitted to the ISC Albacore Working Group Workshop, November 28-December 5, 2006, Shimizu, Shizuoka, Japan. ISC/06/ALBWG/14: 20 p.
- Waterhouse, L., Sampson, D.B., Maunder, M. and Semmens, B.X. 2014. Using areas-as-fleets selectivity to model spatial fishing: Asymptotic curves are unlikely under equilibrium conditions. *Fish. Res.* 158: 15-25. doi: 0.1016/j.fishres.2014.01.009

- Wells, R.J.D., Kohin, S., Teo, S.L.H., Snodgrass, O.E., and Uosaki, K. 2013. Age and growth of North Pacific albacore (*Thunnus alalunga*): Implications for stock assessment. *Fish. Res.* 147: 55– 62. DOI: 10.1016/j.fishres.2013.05.001
- Yabuta, Y., and Yukinawa, M. 1963. Growth and age of albacore. *Rep. Nankai Reg. Fish. Res. Lab.* 17: 111-122.
- Yoshida, H.O. 1968. Early life history and spawning of the albacore, *Thunnus alalunga*, in Hawaiian waters. *Fish. Bull.* 67: 205-211.
- Xu, Y., Sippel, T., Teo, S.L.H., Piner, K., Chen, K.-S., and Wells, R.J. 2014a. A comparison study of North Pacific albacore (*Thunnus alalunga*) age and growth among various sources. Working Paper submitted to the ISC Albacore Working Group Meeting, 14-28 April 2014, La Jolla, USA. ISC/14/ALBWG/04: 13 p. Available at: http://isc.ac.affrc.go.jp/pdf/ALB/ISC14_ALB/ISC-14-ALBWG-04-AGE-GROWTH_YI_etal_finalversion.pdf
- Xu, Y., Teo, S.L.H., and Holmes, J. 2014b. An update of the standardized abundance index of US and Canada Pacific albacore troll and pole-and-line fisheries on the West Coast of North America (1966-2011). Working Paper submitted to the ISC Albacore Working Group Meeting, 14-28 April 2014, La Jolla, USA. ISC/14/ALBWG/03: 8 p. Available at: http://isc.ac.affrc.go.jp/pdf/ALB/ISC14_ALB/ISC-14-ALBWG-03-USCA_CPUE_INDEX_Yi_etal-finalversion.pdf
- Zainuddin, M., Kiyofuji, H., Satoh, K., and Saitoh, S.-I. 2006. Using multi-sensor satellite remote sensing and catch data to detect ocean hot spots for albacore (*Thunnus alalunga*) in the northwestern North Pacific. *Deep-Sea Res. II* 53: 419–431.
- Zainuddin, M., Saitoh, K., and Saitoh, S.-I. 2008. Albacore (*Thunnus alalunga*) fishing ground in relation to oceanographic conditions in the western North Pacific Ocean using remotely sensed satellite data. *Fish. Oceanogr.* 17: 61–73.

TABLES

Table 3.1. Fishery Definitions used in the 2014 assessment of north Pacific albacore.

Spatial Boundaries										
Fishery Number	Fishery Code	N-S	E-W	Primary Gear	Seasons	Catch Unit	Size of Fish ^A	Time Range	Secondary Catches Included	Notes
F1	JPPL_Q12	10-55°N	120°E-120°W	Pole-and-Line	Jan-Mar; Apr-June	Weight		1975-1992	Japan, Korea and Taiwan Gillnet (GN); Japan Miscellaneous (JPM)	
F2	JPPL_Q34	10-55°N	120°E-120°W	Pole-and-Line	July-Sept Oct-Dec	Weight		1993-2012		
F3	JPLLSw_Q12	25-35°N	130-140°E	Longline	Jan-Mar; Apr-June	Weight	Small	1966-2012		
F4	JPLLSw_Q34	25-35°N	130-140°E	Longline	July-Sept; Oct-Dec	Weight	Small	1966-2012		
F5	JPLLSn_Q12	25-35°N	130-140°E	Longline	Jan-Mar; Apr-June	Number of fish	Small	1966-2012		
F6	JPLLSn_Q34	25-35°N	130-140°E	Longline	July-Sept; Oct-Dec	Number of fish	Small	1966-2012		
F7	EPO	20-55°N	110°W-160°E	Troll, Pole-and-line	Jan-Dec	Weight		1966-2012	Mexico purse seine; US Sport; US Miscellaneous	
F8	JPLLLNw_Q14	20-55°N	130°E-180°	Longline	Jan-Mar; Oct-Dec	Weight	Large	1966-1974, 1994-2012	Korea (KR) longline, 1971-1975, 1994-2012	Excludes JPN LLS (F3-F6) area
F9	JPLLLNw_Q23	20-55°N	130°E-180°	Longline	Apr-May; July-Sept	Weight	Large	1966-1974, 1994-2012		Excludes JPN LLS (F3-F6) area
F10	JPLLLNn_Q14	20-55°N	130°E-180°	Longline	Jan-Mar; Oct-Dec	Number of fish	Large	1966-1974, 1994-2012		Excludes JPN LLS (F3-F6) area
F11	JPLLLNn_Q23	20-55°N	130°E-180°	Longline	Apr-May; July-Sept	Number of fish	Large	1966-1974, 1994-2012		Excludes JPN LLS (F3-F6) area
F12	JPLLLNw_Q14	20-55°N	130°E-180°	Longline	Jan-Mar; Oct-Dec	Weight	Large	1975-1993	Korea (KR) longline, 1975-1993	Excludes JPN LLS (F3-F6) area
F13	JPLLLNw_Q23	20-55°N	130°E-180°	Longline	Apr-May; July-Sept	Weight	Large	1975-1993		Excludes JPN LLS (F3-F6) area
F14	JPLLLNw_Q14	20-55°N	130°E-180°	Longline	Jan-Mar; Oct-Dec	Number of fish	Large	1975-1993		Excludes JPN LLS (F3-F6) area
F15	JPLLLNw_Q23	20-55°N	130°E-180°	Longline	Apr-May; July-Sept	Number of fish	Large	1975-1993		Excludes JPN LLS (F3-F6) area
F16	JPLLLSw_Q14	10-20°N	130°E-180°	Longline	Jan-Mar;	Weight	Large	1966-2012		

					Oct-Dec					
F17	JPLLLSw_Q23	10-20°N	130°E-180°	Longline	Apr-May; July-Sept	Weight	Large	1966-2012		
F18	JPLLLSn_Q14	10-20°N	130°E-180°	Longline	Jan-Mar; Oct-Dec	Number of fish	Large	1966-2012		
F19	JPLLLSn_Q23	10-20°N	130°E-180°	Longline	Apr-May; July-Sept	Number of fish	Large	1966-2012		
F20	USLLd	10-25°N	130-170°W	Longline	Jan-Dec	Weight	Large	1966-1978, 1981-1984, 1987-2012	China and other countries longline fisheries (CNO)	Deep set fishery targeting bigeye tuna
F21	USLLs	25-45°N	130-170°W	Longline	Jan-Dec	Weight	Large	1966-1978, 1981-1984, 1987-2000, 2005-2012		Shallow set fishery targeting swordfish; closed by regulation 2001-2004
F22	TWNLLa	25-55°N	145°E- 130°W	Longline	Oct-Dec; Jan-Mar	Number of fish		1995-2012		Taiwan albacore targeting fishery
F23	TWNLLb	0-25°N	120°E- 95°W	Longline	Jan-Mar; Apr-June	Number of fish		1995-2012	JPLL EPOS - south of 25°N	Taiwan non- albacore targeting fishery
F24	JPLL_EPON	25-55°N	120°W- 180°	Longline	Oct-Dec; Jan-Mar	Number of fish		1966-2012		

A – Relative size information provided only if size was a criterion used to define a fishery

Table 3.2. Abundance (CPUE) index descriptions and decisions concerning use in 2014 stock assessment model.

Criterion	Japan LLS	Japan LLL 1975-1992	Japan LLL 1993-2012	Japan LL EPON
Spatial distribution (latitude, longitude)	10° x 10°; 25-35°N, 130-140°E	20-35°N, 130°E-180° (excluding JPN LL-S area)	10-35°N, 130°E -180° excluding JPN LL-S area)	25-35°N, 140-180°W
Size/age range	Small average sized fish with 70-80 cm peak; range 56-116 cm; skewed distribution	Larger average sized fish, range 70-120 cm, peak 100 cm	Larger average sized fish, range 70-120 cm, peak 100cm	Variable size fish, 72-126 cm range, peak 108 cm, skewed to smaller sizes
Contribution to total catch	2-18%	6-22%	11-28%	>0-12% (100-6000 t)
Temporal coverage of data	1975-present	1975-1992	1993-2012	1975-2000
Temporal consistency in size composition	Seasonal changes in size; small in Q1/Q2, larger fish in Q3/Q4, but main catch period is Q1/Q2	Consistent size composition among seasons but in 1980s some interannual differences show up, especially in Q2	Consistent size composition among seasons after 2000 some interannual differences show up, especially in Q1 and Q2 (smaller fish than captured historically)	Plots to come of quarterly size compositions and size composition within core area
Targeting	Primary target species	Bycatch species but seasonally targeted in Q1/Q4	Bycatch species but seasonally targeted in Q1/Q4	Bycatch species
Supporting Working Paper	ISC/13/ALBWG-03/02 ISC/13/ALBWG-03/05	ISC/13/ALBWG-03/02 ISC/13/ALBWG-03/05	ISC/13/ALBWG-03/02 ISC/13/ALBWG-03/05	ISC/13/ALBWG-03/02 ISC/13/ALBWG-03/05
CPUE Decision	Use as sensitivity run but not in base case (S6, S7)	Main adult index in base case model (S1)	Main adult index in base case model (S2)	Not used in base case and will not be used as sensitivity run
Rationale	Based on small spatial area (10 x 10). Early period through 1980s shows declining trend, inconsistent with JPN LL-large; Decline may be related to catchability change not removed by standardization; will investigate cutting into 2 periods and standardizing separately.	Operates over large area of Pacific, long time series, consistent effort in space and time, standardization seems to have accounted for catchability changes	Operates over large area of Pacific, long time series, consistent effort in space and time, standardization seems to have accounted for catchability changes	May have been effort changes in time series that affect catchability and has not been removed by standardization. Index ends in 2000. Not considered representative owing to catchability changes and lack of knowledge concerning target size.

Table 3.2. Continued.

Criterion	TWN LL	Japan DWPL	USLLd	EPO
Spatial distribution (latitude, longitude)	145°E-130°W, 25-40°N – Area A 130°E-110°W, 0-25°N – Area B+C	10-55°N, 130°E-175°W	DS - S of 30°N, 180°-140°W SS - N of 25-30°N, 140-175°W	30-50° N, 120-130°W
Size/age range	60-115 cm – Area A (Group 1) 80-130 cm Areas B+C (Group 2)	Smaller average sized fish, range 50-100 cm; peaks vary by quarter	Deep set: range 80-125 cm, peak 110 cm Shallow set: range 60-125 cm, peak 85 cm	Range 50-90 cm, peak at 65 cm, secondary peak at 77 cm
Relative contribution to catch	>0-10%	14-67%	<1%	5-40%
Temporal coverage of data	1995-2011	1972-2012	1991-2012	1966-2011 – CPUE
Temporal consistency in size composition	Data prior to 2003 are not considered representative of size composition of catch; 2003 onwards data are considered representative	Seasonal changes between Q2 and Q3; large fish in Q2 in 1970s and early 1980s not seen later; may be related to change in fishing grounds	Seasonal consistency in size data within each fishery component. Deep-set stable over long term, shallow less so due to other factors (regulations)	Size composition consistent throughout time series
Targeting	Group 1 target albacore and these sets primarily in Area A; Group 2 target bigeye and these sets largely in Areas B+C	Based on distant water fleet targeting ALB	Non-target for both components	Target species of Canada and US troll/pole-and-line fisheries in eastern Pacific Ocean.
Supporting Working Paper	ISC/13/ALBWG-03/01	ISC/13/ALBWG-03/03		ISC/13/ALBWG-03/06
CPUE Decision	Do not use in base case or as sensitivity run (S5)	Main juvenile index in base case model (S3, S4)	Use deep-set as sensitivity run as has alternate trend in 2000s (S11); shallow set component not used at all.	Use coastal index in sensitivity run as alternate juvenile index (S8, S9, S10).
Rationale	Large spike in CPUE (for Group 1) in late 1990s at beginning of time series, may be related to concentration of effort into small spatial area and inability to remove catchability change during standardization. Needs further investigation. Trends consistent with JPN LL-large in 2000s	Shows coherence with longline index; lower variability than EPO troll; covers large spatial area and temporal period and captures main juvenile size classes; not affected by target switching to SKJ since based on DW vessels. Fishing grounds relatively constant over time series	Relatively small spatial scale and probably on edge of adult distribution so may not be representative of whole stock; regulation changes affected shallow set component and may have affected deep set component.	Index based on small coastal area with high concentration of effort; affected by both stock abundance and migration rate from WCPO and less representative of stock as a whole. Cannot account for migration rate in standardization. Assessment model is not spatially-explicit.

Table 3.3. Standardized values and input CVs of north Pacific albacore annual abundance indices developed for the 2014 base-case model. Units are weight (JPPL fisheries) and number of fish (JPLL, all other indices). Season refers to annual quarters in which majority of catch is made in the underlying fishery, where 1 = Jan-Mar, 2 = Apr-June, 3 = July-Sept, and 4 = Oct-Dec.

Season	S1 JPLLLN 1975-92		S2 JPLLLN 1992-12		S3 JPPL 1975-1989		S4 JPPL 1990-2012		S5 - TWNLLa	
	CPUE	CV	CPUE	CV	CPUE	CV	CPUE	CV	CPUE	CV
	1 and 4		1 and 4		1 and 2		3 and 4		1 and 2	
1972					1.00095	0.2426				
1973					1.17797	0.30087				
1974					1.53736	0.28392				
1975	21.7971	0.20316			1.21214	0.26029				
1976	27.9512	0.20378			1.30298	0.28073				
1977	29.1526	0.20296			0.70085	0.24899				
1978	26.3465	0.20348			1.08613	0.31924				
1979	22.9145	0.20106			1.06246	0.28771				
1980	22.8578	0.19975			0.97872	0.23249				
1981	22.0833	0.1985			0.57422	0.22481				
1982	19.4026	0.19851			0.88105	0.20925				
1983	17.6146	0.19808			0.92007	0.24103				
1984	15.0077	0.19754			1.27886	0.24053				
1985	12.8628	0.19712			1.29541	0.26595				
1986	14.5181	0.1976			0.88796	0.22096				
1987	20.4145	0.20234			0.53933	0.251				
1988	12.9191	0.19975			0.62286	0.16695				
1989	12.6763	0.1975			0.94069	0.18031				
1990	14.3893	0.19956					0.60273	0.18091		
1991	13.4898	0.19905					0.58362	0.19215		
1992	16.4691	0.20027					0.68533	0.23186		
1993			11.2599	0.19702			0.74507	0.18303		
1994			14.7421	0.19793			1.53368	0.19501		
1995			16.3807	0.19846			1.28329	0.18765	26.97560	0.22004
1996			21.1598	0.2007			1.52723	0.22657	41.97689	0.19288
1997			21.3035	0.20134			1.39403	0.22237	41.38511	0.19425
1998			23.6528	0.20243			1.20692	0.20163	17.99401	0.22912
1999			23.7244	0.20231			1.74071	0.21979	18.42419	0.24236
2000			25.2935	0.20443			0.79418	0.19989	17.53034	0.23251
2001			21.188	0.20096			0.94928	0.21304	10.80661	0.25617
2002			17.6526	0.19948			1.73794	0.22371	10.54262	0.26379
2003			13.9778	0.19751			1.28954	0.23034	11.91201	0.26736
2004			15.5525	0.19943			0.8699	0.19438	6.64921	0.38562
2005			16.626	0.19906			0.43896	0.17885	7.63460	0.36515
2006			19.6531	0.20051			0.48099	0.18007	11.69596	0.35945
2007			21.4762	0.20095			0.8859	0.19724	11.48768	0.33761
2008			14.2337	0.19757			0.41569	0.18121	15.28117	0.28288
2009			20.7563	0.20075			1.19995	0.19084	13.20841	0.27777
2010			18.0541	0.1992			0.56475	0.17780	21.55885	0.24353
2011			18.8964	0.19975			0.87609	0.18205	18.63538	0.24894
2012			19.7088	0.20022			1.19422	0.20963		

Table 3.3. Continued.

Season	S6 JPLLS 1975-88		S7 JPLLS 1989-2012		S8 EPO 1966-78		S9 EPO 1979-98		S10 EPO 1999-2012		S11 USLLd	
	CPUE	CV	CPUE	CV	CPUE	CV	CPUE	CV	CPUE	CV	CPUE	CV
	1 and 2		1 and 2		3		3		3		1 and 4	
1966					62.14973	0.20588						
1967					86.28644	0.20871						
1968					72.28511	0.20234						
1969					61.83722	0.20071						
1970					84.79845	0.20795						
1971					69.25752	0.21117						
1972					50.25199	0.19018						
1973					46.07107	0.19249						
1974					56.02865	0.19636						
1975	22.0024	0.22187			68.56263	0.19549						
1976	27.4177	0.22745			50.41051	0.19141						
1977	17.7642	0.20781			34.84447	0.19491						
1978	5.1683	0.18506			53.89192	0.20238						
1979	5.1380	0.18401					41.2260	0.18610				
1980	14.2956	0.20196					25.4627	0.19149				
1981	7.5362	0.19004					45.5932	0.18578				
1982	11.3024	0.19550					49.8730	0.17859				
1983	13.3829	0.20037					47.5884	0.16127				
1984	13.5126	0.20501					60.6728	0.17890				
1985	10.1736	0.19336					67.1287	0.17096				
1986	13.9172	0.20252					32.1341	0.21052				
1987	8.4656	0.19351					22.5126	0.24910				
1988	7.9320	0.19152					53.1185	0.25373				
1989			31.5993	0.23065			23.5917	0.23174				
1990			30.0392	0.21095			31.1465	0.23696				
1991			27.1258	0.21425			30.4731	0.28826			0.6370	0.20250
1992			31.1363	0.22627			62.8494	0.20100			0.4636	0.20569
1993			56.1833	0.23603			51.9172	0.17187			0.8014	0.19719
1994			38.5954	0.19450			71.3800	0.19028			1.0217	0.19633
1995			39.0686	0.19745			36.5627	0.18051			1.5684	0.18923
1996			46.7599	0.19776			51.6534	0.18191			1.8433	0.18358
1997			54.0259	0.20147			48.5596	0.17714			2.0707	0.18930
1998			44.6327	0.19703			85.9409	0.17391			1.5272	0.18570
1999			34.4612	0.19322					42.9120	0.20331	1.8532	0.18370
2000			44.5231	0.19755					45.7539	0.19806	0.5365	0.20165
2001			30.7704	0.19232					61.0606	0.19254	0.9320	0.19315

2002	36.9496	0.19393	81.2548	0.19424	0.2589	0.20366
2003	45.9981	0.19690	88.2863	0.18820	0.2128	0.20589
2004	20.2431	0.18780	101.0463	0.19064	0.1733	0.20625
2005	23.8228	0.19022	56.4344	0.19402	0.1578	0.20520
2006	33.7676	0.19225	83.5074	0.19887	0.1052	0.20775
2007	39.9302	0.19654	66.9787	0.20426	0.0877	0.20949
2008	26.6095	0.19012	59.6743	0.22565	0.1109	0.20734
2009	35.3659	0.19313	69.8722	0.19848	0.0572	0.21280
2010	25.4066	0.18910	56.4578	0.20878	0.1452	0.20635
2011	23.8848	0.18873	49.3892	0.20296	0.2239	0.20352
2012	37.7344	0.19182			0.1946	0.20374

Table 3.4. Sex ratio by latitude of longline catches made by Japanese training vessels, including both pole-and-line and longline gears, 1987-present. Data are aggregated across gear and years.

Latitude band	Sex ratio (males/females)	Sample size
10-25°N	4.78	2,288
> 25°N	1.93	1,259

Table 4.1. Key life history parameters and model structures used in the base-case model.

Parameter	Value	Comments	Source
Natural mortality (M)	0.3 y ⁻¹	Non sex-specific, non age-specific, fixed parameter	ICCAT (2010)
Length at age 1 (L ₁)	Female: 43.504 cm Male: 47.563 cm	Fixed parameter	Xu et al. (2014a)
Asymptotic length (L _∞)	Female: 106.57 cm Male: 119.15 cm	Fixed parameter	Xu et al. (2014a)
Growth rate (K)	Female: 0.29763 y ⁻¹ Male: 0.20769 y ⁻¹	Fixed parameter	Xu et al. (2014a)
CV of L ₁	0.06	Non sex-specific, fixed parameter	ALBWG (2014)
CV of L _∞	0.04	Non sex-specific, fixed parameter	ALBWG (2014)
Weight-at-length – Q1	$W_L \text{ (kg)} = 8.7 * 10^{-5} L \text{ (cm)}^{2.67}$	Non sex-specific, fixed parameters	Watanable et al. (2006)
Weight-at-length – Q2	$W_L \text{ (kg)} = 3.9 * 10^{-5} L \text{ (cm)}^{2.84}$	Non sex-specific, fixed parameters	Watanable et al. (2006)
Weight-at-length – Q3	$W_L \text{ (kg)} = 2.1 * 10^{-5} L \text{ (cm)}^{2.99}$	Non sex-specific, fixed parameters	Watanable et al. (2006)
Weight-at-length – Q4	$W_L \text{ (kg)} = 2.8 * 10^{-5} L \text{ (cm)}^{2.92}$	Non sex-specific, fixed parameters	Watanable et al. (2006)
Maturity	50% at age-5, 100% age-6+	Fixed parameters	Ueyanagi (1957)
Fecundity	Proportional to spawning biomass	Fixed parameters	Ueyanagi (1957)
Spawning season	2	Model structure	Ueyanagi (1957); Chen et al. (2010)
Spawner-recruit relationship	Beverton-Holt	Model structure	

Spawner-recruit steepness (h)	0.9	Fixed parameter	Brodziak et al. (2011); Iwata et al. (2014); ALBWG (2014)
Log of Recruitment at virgin biomass $\ln(R_0)$	10.7727	Maximum likelihood estimate	
Recruitment variability (σ_R)	0.5	Fixed parameter	
Initial age structure	10 y	Estimated	
Main recruitment deviations	1966-2012	Estimated	
Selectivity	Dome-shaped: F1, F2, F3, F4, F7, F8, F21, F22, & F24 Logistic: F12, F16, F17, & F20 Shared selectivity: F5, F6, F9, F10, F11, F13, F14, F15, F18, F19, & F23	Estimated (see Table 4.3)	ALBWG (2014)
Catchability		Solved analytically	

Table 4.2. Von Bertalanffy growth curves used in the 2014 north Pacific albacore base-case model and sensitivity runs.

Study	Sex	L_1 (cm)	L_{inf} (cm)	K (y^{-1})	Model
Xu et al. (2014a)	Female	43.504	106.57	0.29763	Base case
	Male	47.563	119.15	0.20769	Base case
	Sex-combined	45.628	112.379	0.2483	Sensitivity 03
Chen et al. (2012)	Female	41.979	103.5	0.340	Sensitivity 01
	Male	45.443	114.0	0.253	Sensitivity 01

Table 4.3. Selectivity parameters used in the base-case model. Estimated parameters are shown in bold, with estimated CVs (%) in parentheses. The optional initial and final parameters for all double-normal selectivity curves were fixed at -999 and ignored by the model. The 1975-1992 period of F8 is modeled as a separate fishery, F12, with a different selectivity.

Fishery	Years	Parm 1 - Size at peak	Parm 2 - Plateau width	Parm 3 - Ascending slope	Parm 4 - Descending slope
Dome-shaped (Double-normal)					
F1	1966-1989	86.124 (2.8)	-8	5.950 (3.8)	3.909 (15)
	1990-2012	81.911 (4.3)	-8	5.783 (5.8)	4.229 (19)
F2	1966-1989	84.993 (4.7)	-8.107 (257)	7.052 (8.5)	2.623 (78)
	1990-2012	54.975 (5.5)	-0.950 (30)	3.310 (37)	4.136 (28)
F3	1966-1983	74.175 (5.1)	-7.815 (332)	3.662 (32)	7.116 (12)
	1984-1993	78.092 (5.2)	1.199 (2785)	4.365 (20)	4.413 (2696)
	1994-2012	75.180 (1.9)	-8.682 (101)	3.443 (15)	5.894 (5.3)
F4	1966-1988	104.92 (9.2)	-1.052 (585)	4.979 (21)	2.455 (1313)
	1989-2012	98.546 (6.0)	-2.576 (159)	4.853 (14)	4.023 (61)
F7	1966-1974	63.576 (5.0)	-8	3.214 (33)	5.347 (11)
	1975-1987	64.228 (3.2)	-8	4.202 (10)	5.732 (4.9)
	1988-1995	60.977 (4.5)	-8	3.168 (27)	5.612 (7.3)
	1996-2012	65.694 (2.7)	-2.878 (52)	3.492 (13)	4.858 (13.9)
F8	1966-1974	118.493 (6.1)	-5.842 (936)	6.624 (4.2)	-2.818 (1041)
	1993-2012	116.986 (6.3)	-6.214 (803)	6.317 (4.2)	2.221 (353)
F21	1966-2004	99.920 (19)	1	6.181 (18)	2.677 (5221)
	2005-2012	82.262 (13)	1	5.237 (24)	4.355 (1981)
F22	1966-2012	87.808 (4.0)	1	5.255 (7.5)	5.063 (1380)
F24	1966-2012	111.5 (12)	-2.118 (340)	6.153 (10)	2.406 (457)
Logistic (Asymptotic)					
		Parm 1 - Size at inflection	Parm 2 - Width for 95% selection		
F12	1975-1992	112.576 (7.3)	24.927 (12)		
F16	1966-1984	119.399 (3.3)	11.572 (13)		
	1985-1992	126.632 (5.2)	8.435 (23)		
F17	1966-1984	119.984 (4.9)	11.468 (20)		
	1985-1992	126.775 (3.5)	8.806 (14)		
F20	1966-2012	109.827 (4.0)	15.318 (12)		
Mirrored Selectivity					
	Mirrored to				
F5	F3				
F6	F4				
F9, F10, F11	F8				
F13, F14, F15	F12				
F18	F16				
F19	F17				
F23	F20				

Table 4.4. Variance adjustment factors used in the base case model. Fisheries with neither abundance indices nor size composition data are not shown.

Fishery	Additional CV for indices	Multipliers on sample size for size composition data
F1	0.0	0.03
F2	0.1	0.03
F3	-	0.03
F4	-	0.03
F7	-	0.045
F8	0.0	0.03
F9	-	0.03
F12	0.0	0.03
F13	-	0.03
F16	-	0.06
F17	-	0.06
F20	-	0.06
F21	-	0.06
F22	-	0.06
F24	-	0.06

Table 4.5. Sensitivity analyses conducted on the 2014 base case model for north Pacific albacore.

Sensitivity Run Number	Sensitivity Name	Description
Sensitivity to Biological Assumptions		
01	Growth hypothesis 1	Use Chen et al. (2012) sex-specific growth model. Assume F16-20 selectivity identical to F8 and not fit to F16-20 size composition data. This allows us to remove the approximate correct number of fish from F16-20 but assume that the vast majority of adult albacore are in more subtropical and temperate waters (e.g., F8) and hence do not grow as large as the fish from F16-20. Therefore, size composition data from F16-20 are likely not to be highly informative on the population dynamics.
02	CV of L_{inf}	The CV of L_{inf} is estimated or fixed at higher (0.06 & 0.08) levels. Lower CV levels were not investigated because CV values smaller than the base case model (0.04) was considered unreasonable.
03	Non sex-specific growth	Use Xu et al. (2014) non sex-specific growth model that combined data from Wells et al. (2014) and Chen et al. (2012). Model structure is otherwise identical to base-case model.
04	Stock-recruitment steepness	Use alternative values for the steepness parameter ($h = 0.75, 0.85, 0.95$).
05	Natural mortality	Use alternative values for the natural mortality parameter ($M=0.25, 0.35, \text{ and } 0.45$).
Sensitivity to Data Inputs		
06	Alternative juvenile indices	Use the S6 and S7 (Japan longline) and S8-10 (EPO surface) indices instead of S3 and S4 (Japan pole-and-line) indices as indicators of juvenile population trends.
07	CV of juvenile indices	The average CV of the F1 and F2 index is estimated or fixed at 0.2 using the variance adjustment parameters.
08	Alternative adult indices	Use the S11 (US longline) and S5 (Taiwan longline albacore-targeting) indices instead of S2 (Japan longline) index (1993-2012) as an indicator of adult population trends
09	Start year	Start year of the model is changed to 1952 (earliest available catch data) or 1975 (start of relative abundance data). The 1952 model assumed that all catches during 1952-1965 were assigned to three largest fisheries: Japanese pole-and-line (F1, F2), Japanese longline (F8, F9), and EPO surface (F7) fisheries. It was also fit to the initial equilibrium catch, calculated as the catch from 1952-1954.
10	Size composition weighting	Change the relative weighting of the size composition data by 10-fold (higher and lower) or using the natural weight (variance adjustment = 1.0) of the data.

Table 5.1. Relative negative log-likelihoods of abundance index data components in the 2014 base-case model over a range of fixed levels of virgin recruitment in log-scale [$\ln(R_0)$]. Likelihoods are relative to the minimum negative log-likelihood (best-fit) for each respective data component. Colors indicate relative likelihood (green: low negative log-likelihood, better-fit; red: high negative log-likelihood, poorer-fit). Maximum likelihood estimate of $\ln(R_0)$ is 10.77.

$\ln(R_0)$	S3	S4	S2	S1	Sum
10.0	0.39	0.30	0.94	0.20	0.98
10.1	0.39	0.22	0.98	0.16	0.90
10.2	0.38	0.16	1.02	0.13	0.84
10.3	0.35	0.13	1.01	0.08	0.73
10.4	0.23	0.00	0.72	0.02	0.11
10.5	0.20	0.02	0.63	0.00	0.00
10.6	0.19	0.10	0.64	0.00	0.08
10.7	0.17	0.15	0.52	0.03	0.02
10.8	0.15	0.22	0.40	0.10	0.02
10.9	0.12	0.29	0.29	0.19	0.03
11.0	0.09	0.34	0.20	0.28	0.07
11.1	0.07	0.38	0.12	0.39	0.11
11.2	0.05	0.42	0.07	0.50	0.17
11.3	0.03	0.44	0.03	0.60	0.25
11.4	0.01	0.46	0.01	0.69	0.32
11.5	0.00	0.47	0.00	0.78	0.40

Table 5.2. Relative negative log-likelihoods of size composition data components in the 2014 base-case model over a range of fixed levels of virgin recruitment in log-scale [$\ln(R_0)$]. Likelihoods are relative to the minimum negative log-likelihood (best-fit) for each respective data component. Colors indicate relative likelihood (green: low negative log-likelihood, better-fit; red: high negative log-likelihood, poorer-fit). Maximum likelihood estimate of $\ln(R_0)$ is 10.77.

$\ln(R_0)$	F1	F2	F3	F4	F7	F8	F12	F16	F17	F20	F21	F22	F24	Sum
10.0	1.26	1.11	1.38	0.17	0.00	0.57	0.1	0.33	1.24	0.22	0.00	0.00	0.52	2.19
10.1	1.22	1.06	1.38	0.14	0.08	0.36	0.06	0.29	1.15	0.11	0.01	0.07	0.47	1.70
10.2	1.19	1.01	1.38	0.11	0.16	0.16	0.03	0.26	1.06	0.05	0.01	0.14	0.43	1.29
10.3	1.16	0.95	1.38	0.09	0.24	0.00	0.01	0.21	0.97	0.03	0.03	0.21	0.39	0.98
10.4	1.06	0.85	1.19	0.08	0.30	0.40	0.00	0.14	0.81	0.09	0.07	0.33	0.35	0.99
10.5	0.97	0.76	1.03	0.06	0.39	0.27	0.01	0.12	0.69	0.10	0.12	0.51	0.32	0.64
10.6	0.80	0.64	0.76	0.04	0.48	0.01	0.05	0.08	0.60	0.09	0.19	0.77	0.34	0.16
10.7	0.67	0.53	0.53	0.02	0.57	0.01	0.06	0.06	0.44	0.07	0.32	1.13	0.30	0.00
10.8	0.53	0.41	0.32	0.01	0.66	0.02	0.08	0.05	0.32	0.03	0.48	1.58	0.26	0.06
10.9	0.37	0.30	0.15	0.01	0.75	0.11	0.11	0.02	0.23	0.01	0.67	2.11	0.24	0.37
11.0	0.23	0.20	0.05	0.00	0.83	0.20	0.13	0.00	0.17	0.00	0.86	2.64	0.22	0.83
11.1	0.15	0.14	0.00	0.00	0.89	0.23	0.14	0.01	0.12	0.01	1.03	3.12	0.17	1.33
11.2	0.10	0.09	0.00	0.00	0.94	0.25	0.15	0.03	0.08	0.02	1.19	3.55	0.12	1.82
11.3	0.06	0.05	0.01	0.00	0.99	0.27	0.16	0.05	0.05	0.03	1.33	3.92	0.07	2.28
11.4	0.03	0.02	0.04	0.00	1.02	0.29	0.16	0.07	0.02	0.04	1.45	4.24	0.03	2.71
11.5	0.00	0.00	0.07	0.00	1.06	0.31	0.17	0.08	0.00	0.06	1.55	4.51	0.00	3.10

Table 5.3. Analytical estimates of catchability, mean input variance, variance adjustment, and model fit (root-mean-square-error; RMSE of predictions to observations) for juvenile (F1 and F2) and adult (F8 and F12) annual abundance indices in the 2014 base-case model.

Index	Years	Catchability (q)	Mean Input CV	Variance Adjustment	Input CV + Var. Adj.	RMSE
S1	1975 – 1992	5.51E-03	0.20	0.0	0.20	0.140
S2	1993 – 2012	2.13E-03	0.20	0.0	0.20	0.169
S3	1972 – 1989	3.26E-06	0.25	0.0	0.25	0.242
S4	1990 – 2012	2.55E-06	0.20	0.1	0.30	0.385

Table 5.4. Mean input variances (input N after variance adjustment) and model estimated mean variance (*effN*) of the size composition data components of the base-case model. Harmonic means of the *effN* and the ratio of input N to *effN* are also provided. A higher *effN* indicates a better model fit. Number of observations corresponds to the number of quarters in which size composition data were sampled in a fishery.

Fishery	Number of observations	Mean input N after var adj	Mean <i>effN</i>	Harmonic mean <i>effN</i>	Mean (<i>effN</i> /inputN)
F1	60	3.01	30.5	8.6	10.4
F2	55	1.75	22.1	5.6	14.2
F3	75	2.95	40.9	14.4	17.2
F4	33	1.75	65.9	31.9	44.0
F7	87	3.70	59.6	29.4	27.0
F8	58	4.03	113.3	58.6	29.2
F12	36	3.83	77.6	52.5	21.9
F16	39	1.84	58.8	41.7	36.9
F17	31	1.77	53.3	41.4	34.8
F20	63	2.37	60.7	32.2	30.8
F21	24	1.45	50.8	32.2	35.1
F22	21	4.56	62.6	28.6	14.5
F24	29	1.46	46.7	16.1	29.8

Table 5.5. Total biomass (Q1, age-1+), female spawning biomass (Q2), depletion (SSB/SSB₀), recruitment, and fishing intensity (1-SPR) estimated in the base-case model. Estimated virgin biomass (SSB₀) and recruitment are 307830 mt and 47.7 million fish, respectively.

Year	Total biomass age-1+ (mt)	Female spawning biomass (mt)	Depletion (SSB/SSB ₀)	Recruitment (x1000 fish)	Fishing intensity (1-SPR)
1966	899,456	139,228	0.45	50,537.0	0.41
1967	951,406	164,889	0.54	54,486.8	0.48
1968	966,449	177,937	0.58	59,871.9	0.41
1969	994,753	181,150	0.59	63,686.5	0.43
1970	1,020,990	193,164	0.63	46,592.6	0.39
1971	1,041,570	204,401	0.66	64,594.1	0.49
1972	1,030,080	200,361	0.65	50,895.5	0.56
1973	1,003,480	196,493	0.64	52,900.1	0.57
1974	968,680	191,260	0.62	47,159.3	0.62
1975	920,028	177,447	0.58	57,292.8	0.55
1976	898,853	170,102	0.55	45,402.4	0.68
1977	847,231	157,892	0.51	28,591.9	0.44
1978	837,454	156,534	0.51	32,730.1	0.60
1979	764,258	152,627	0.50	37,601.1	0.51
1980	721,195	155,319	0.50	40,204.8	0.57
1981	685,437	149,945	0.49	36,673.7	0.59
1982	657,945	132,120	0.43	44,253.5	0.59
1983	647,888	117,339	0.38	28,703.3	0.49
1984	652,088	113,733	0.37	22,928.3	0.57
1985	615,636	113,676	0.37	29,530.2	0.52
1986	582,631	113,683	0.37	34,707.4	0.46
1987	572,276	118,629	0.39	21,777.2	0.49
1988	558,071	116,638	0.38	30,306.7	0.47
1989	544,126	108,152	0.35	35,982.5	0.47
1990	545,348	102,713	0.33	47,141.0	0.54
1991	560,335	103,931	0.34	36,436.4	0.40
1992	604,220	102,318	0.33	49,896.7	0.49
1993	636,216	97,569	0.32	52,865.6	0.48
1994	687,085	100,397	0.33	50,955.3	0.55
1995	723,459	111,198	0.36	32,868.5	0.50
1996	746,677	118,794	0.39	56,358.9	0.53
1997	751,680	123,192	0.40	36,547.7	0.62
1998	737,880	129,443	0.42	34,848.9	0.58
1999	713,760	134,877	0.44	53,898.1	0.71
2000	666,198	121,487	0.39	47,087.8	0.59

Table 5.5. continued.

Year	Total biomass age-1+ (mt)	Female spawning biomass (mt)	Depletion (SSB/SSB ₀)	Recruitment (x1000 fish)	Fishing intensity (1-SPR)
2001	679,665	120,367	0.39	41,338.5	0.59
2002	684,978	119,047	0.39	36,654.8	0.65
2003	658,252	111,833	0.36	32,209.0	0.62
2004	627,681	113,844	0.37	52,770.9	0.66
2005	605,744	112,767	0.37	40,429.7	0.54
2006	629,541	110,282	0.36	39,417.0	0.54
2007	644,255	106,245	0.35	41,918.4	0.66
2008	629,823	98,562	0.32	44,596.2	0.53
2009	649,248	105,012	0.34	38,401.7	0.60
2010	651,095	109,212	0.35	42,968.3	0.53
2011	661,489	110,655	0.36	48,285.0	0.57
2012	669,405	110,101	0.36	45,436.3	0.59

Table 5.6. Potential reference points and estimated F-ratios (Reference Point/F) using $F_{2010-2012}$ and $F_{2002-2004}$ (reference years for north Pacific albacore CMMs adopted by the IATTC and WCPFC) to assess current stock status, associated spawning biomass and equilibrium yield for north Pacific albacore when exploited at $F_{2002-2004}$ or $F_{2010-2012}$. Median SSB and yield are shown for $F_{SSB-ATHL}$ as this simulation-based reference point is a non-equilibrium based concept.

Reference Point	Reference Point Ratio	Female Spawning Biomass (t)	Equilibrium Yield (t)
$F_{2010-2012}$ (Fcurrent in the 2014 assessment)			
$F_{SSB-ATHL}$	0.72	100,344	90,256
F_{MSY}	0.52	49,680	105,571
$F_{0.1}$	0.51	73,380	93,939
F_{MED}	1.30	156,291	74,640
$F_{10\%}$	0.63	22,867	96,590
$F_{20\%}$	0.71	54,530	105,418
$F_{30\%}$	0.81	86,192	99,612
$F_{40\%}$	0.94	117,855	89,568
$F_{50\%}$	1.13	149,517	77,429
$F_{2002-2004}$ (Reference for existing CMMs)			
$F_{SSB-ATHL}$	0.85	87,164	97,079
F_{MSY}	0.76	47,916	101,429
$F_{0.1}$	0.56	57,140	92,923
F_{MED}	1.34	156,291	69,288
$F_{10\%}$	0.71	22,867	93,303
$F_{20\%}$	0.80	54,530	101,135
$F_{30\%}$	0.92	86,192	94,712
$F_{40\%}$	1.07	117,855	84,296
$F_{50\%}$	1.29	149,517	72,059

FIGURES

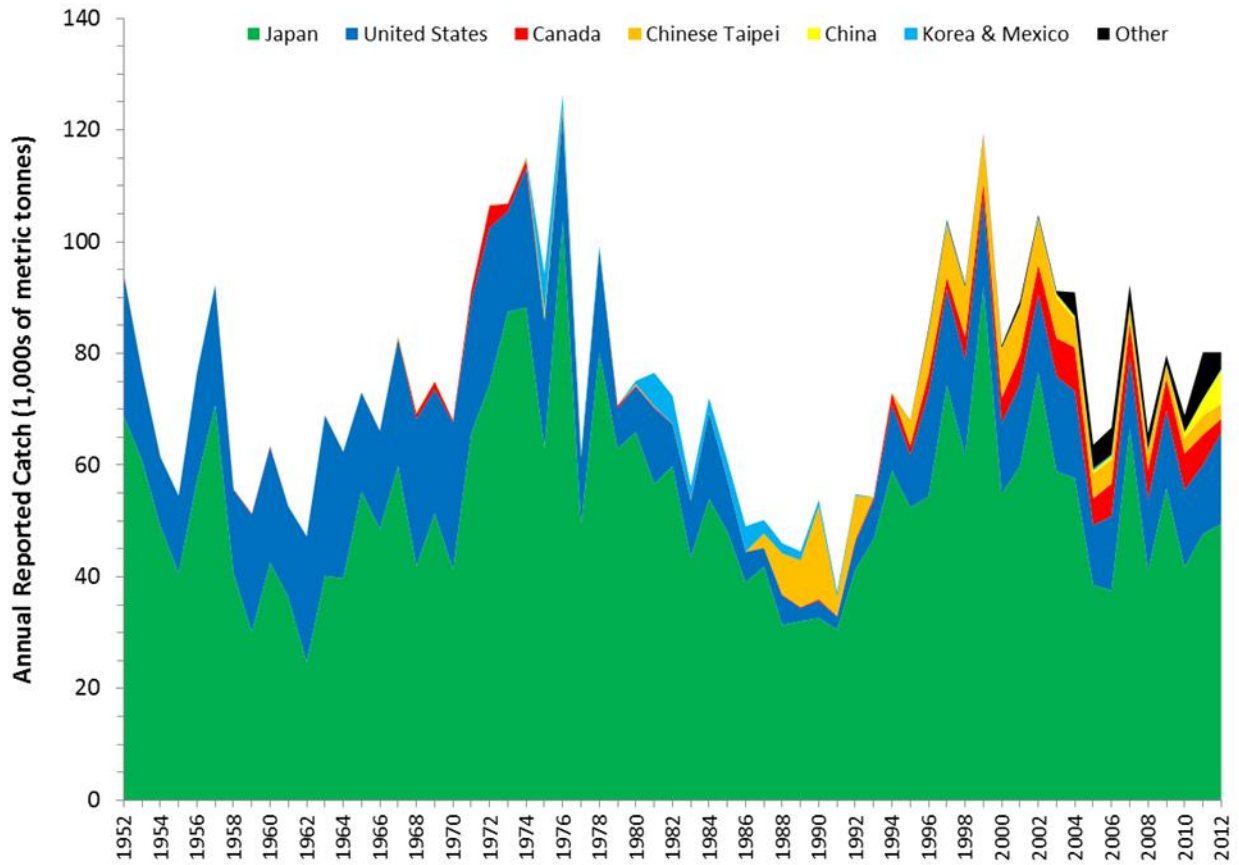

Figure 2.1. Total annual reported catch of north Pacific albacore (*Thunnus alalunga*) by ISC member countries and non-member countries, 1952-2012. Non-ISC member countries are grouped in the Other category and include Tonga, Belize, Cook Islands, Ecuador, Vanuatu, Vietnam and longline vessels flying flags of convenience.

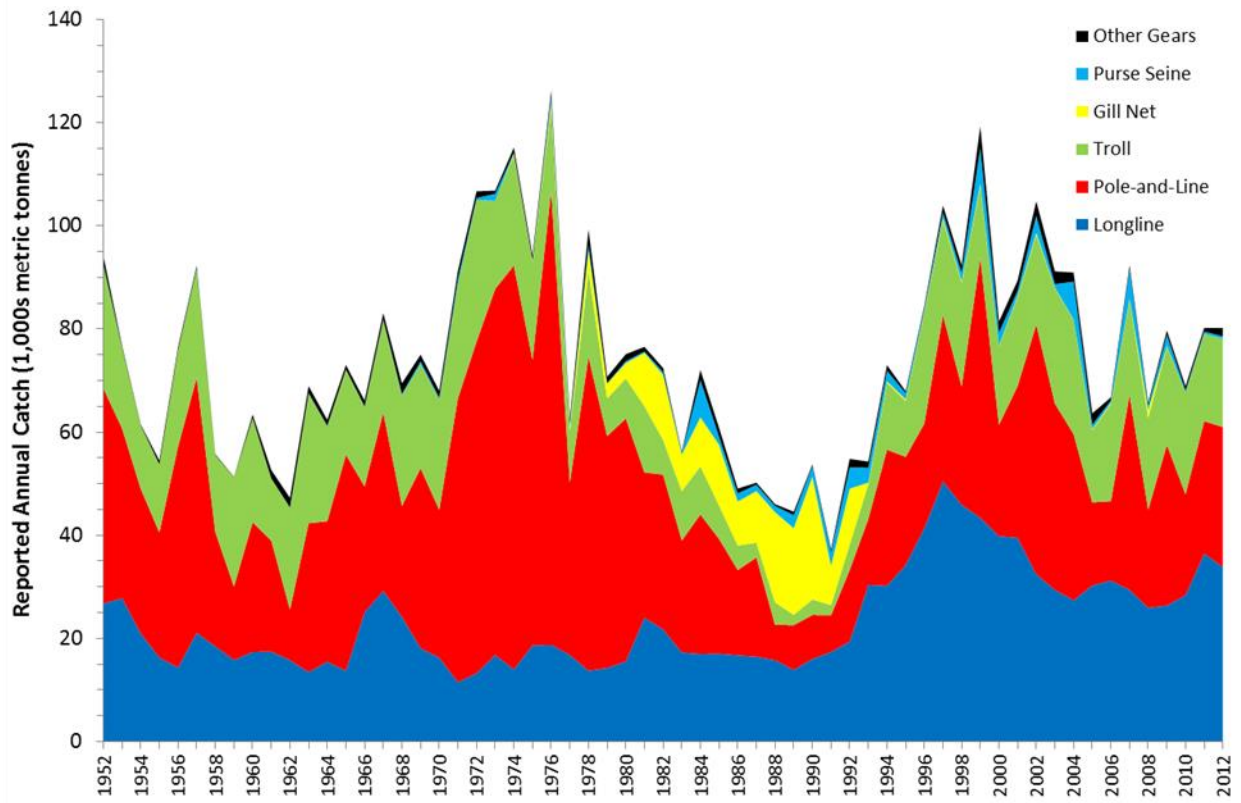

Figure 2.2. Catches of north Pacific albacore by major gear types, 1966-2012. The Other Gears category includes set nets, recreational, hand line, and harpoon.

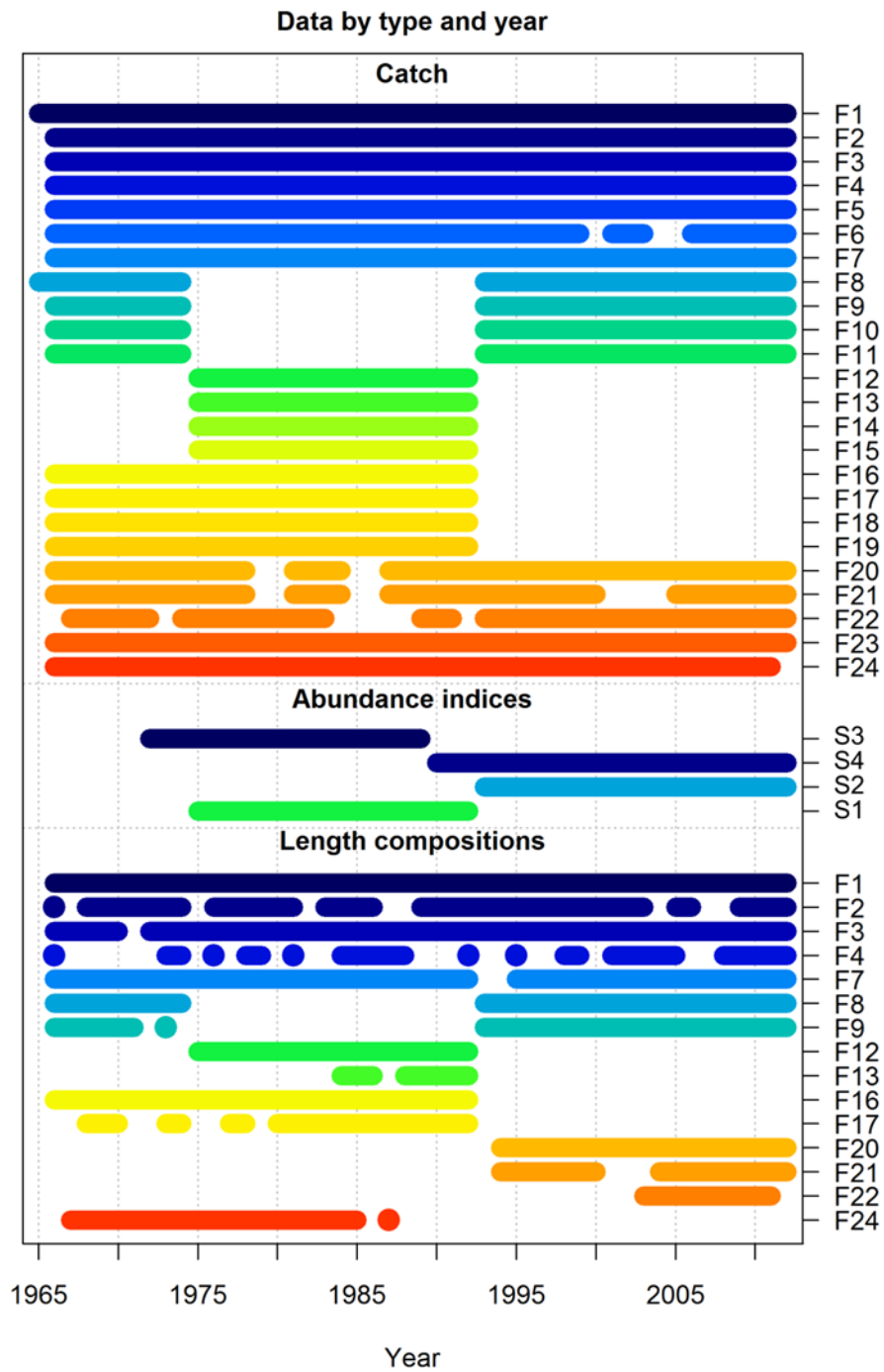

Figure 3.1. Temporal coverage and sources of catch, abundance indices, and length composition data by fishery used in the 2014 assessment of north Pacific albacore tuna. See the text and Table 3.1 for fishery codes.

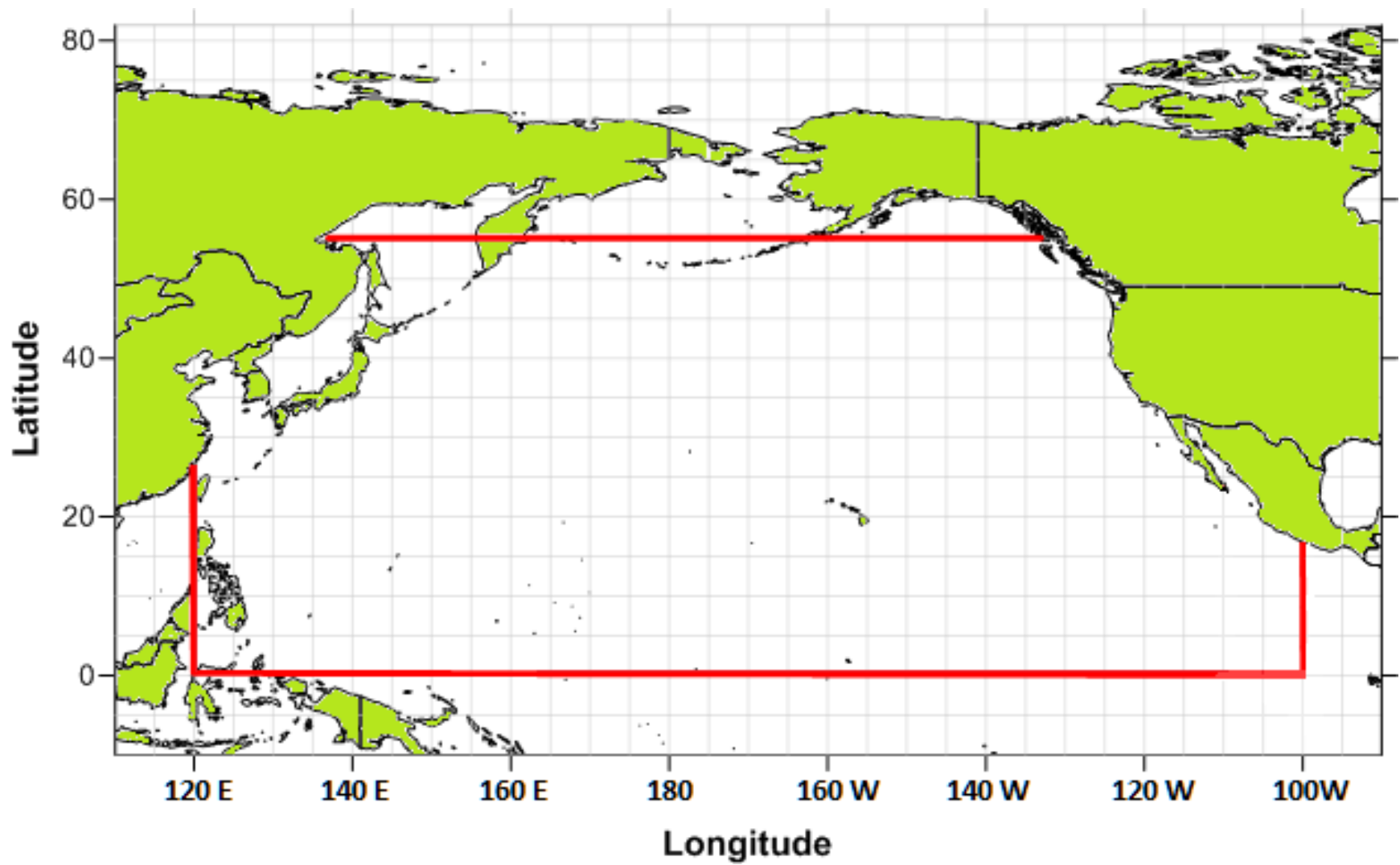

Figure 3.2. Spatial domain (red box) of the north Pacific albacore stock (*Thunnus alalunga*) and the 2014 stock assessment.

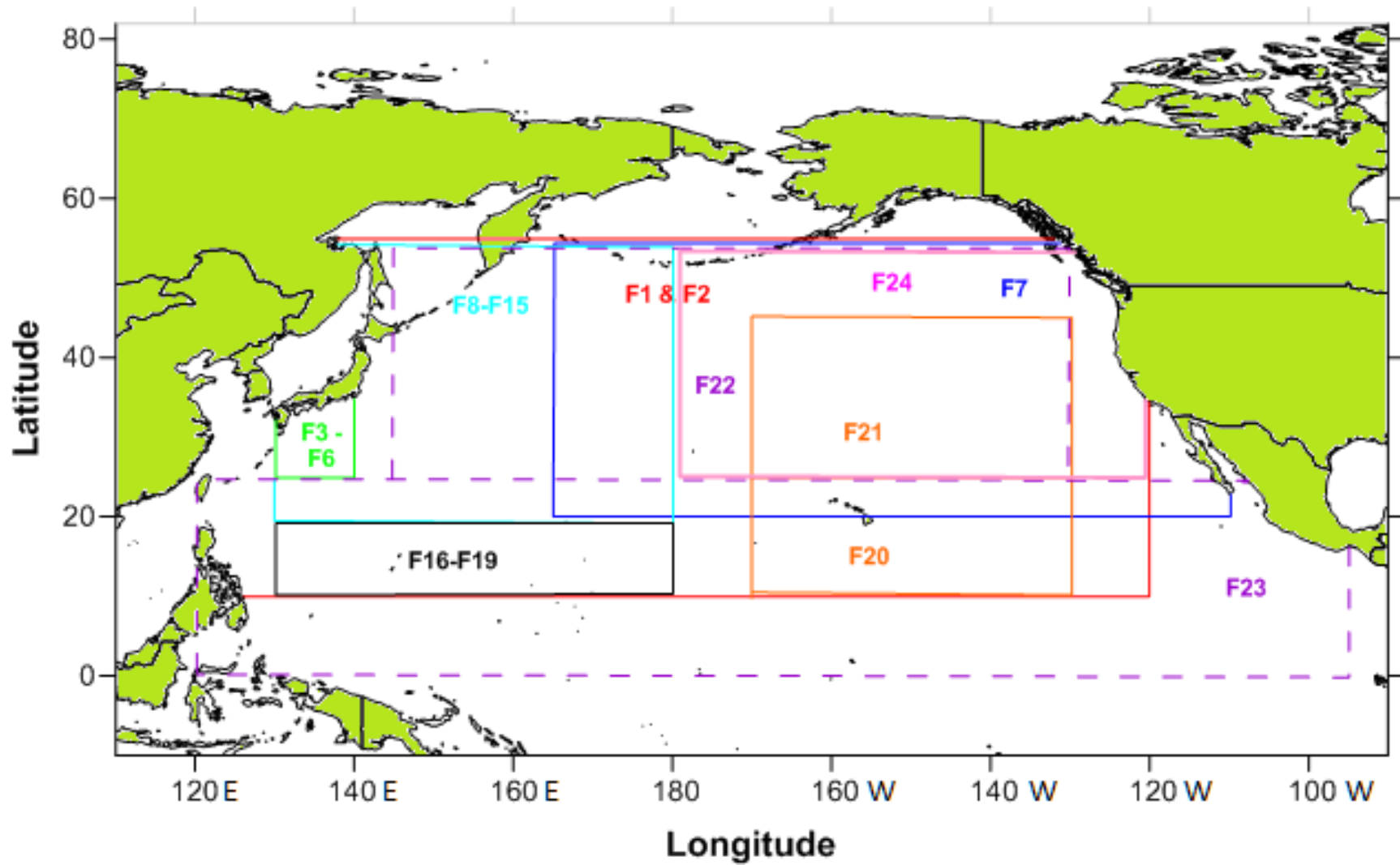

Figure 3.3. Operational areas of 24 fisheries defined for the 2014 north Pacific albacore tuna (*Thunnus alalunga*) stock assessment. See text and Table 3.1 for fishery descriptions.

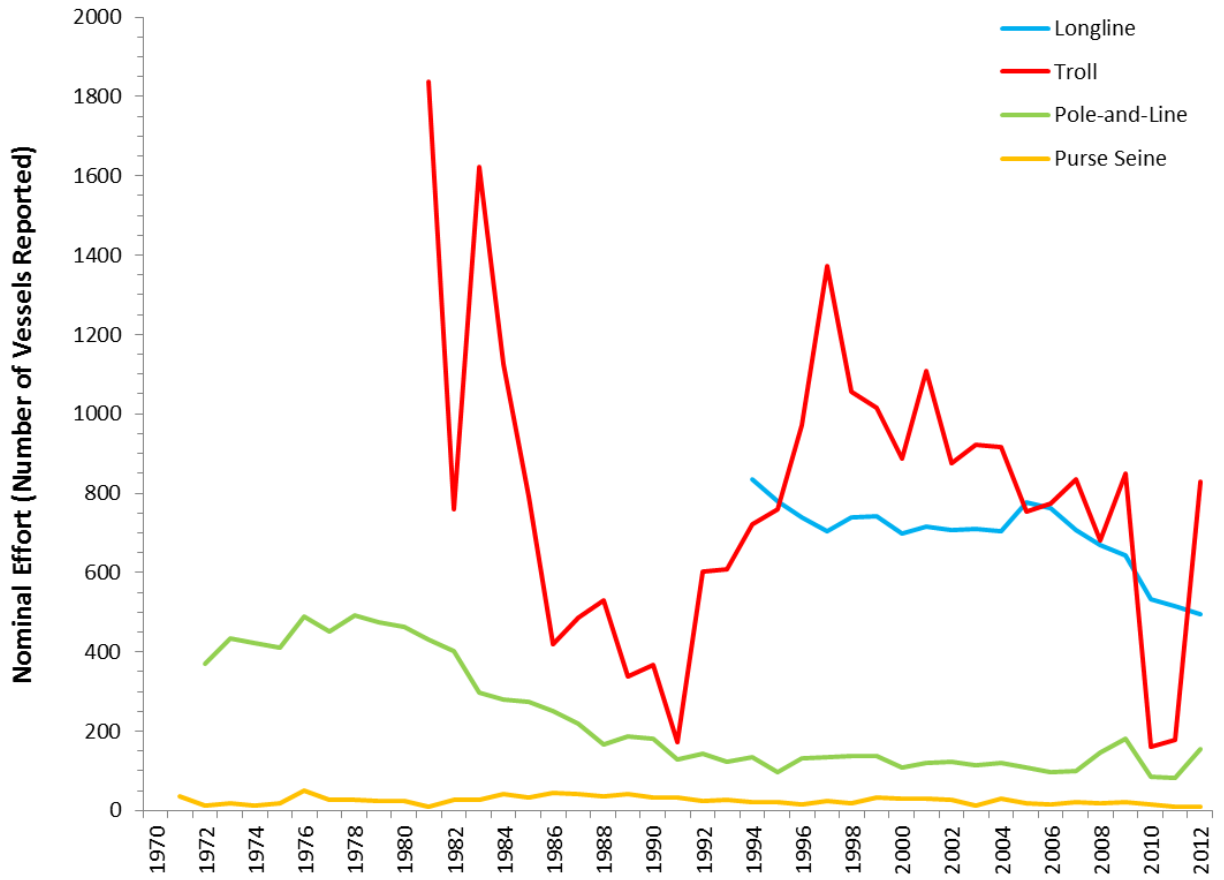

Figure 3.4. Nominal effort of ISC member countries (1970-2012) measured as the number of vessels reported for the major gear types catching north Pacific albacore, *Thunnus alalunga* compiled by the ALBWG. Records of the number of longline vessels prior to 1994 are incomplete and not shown.

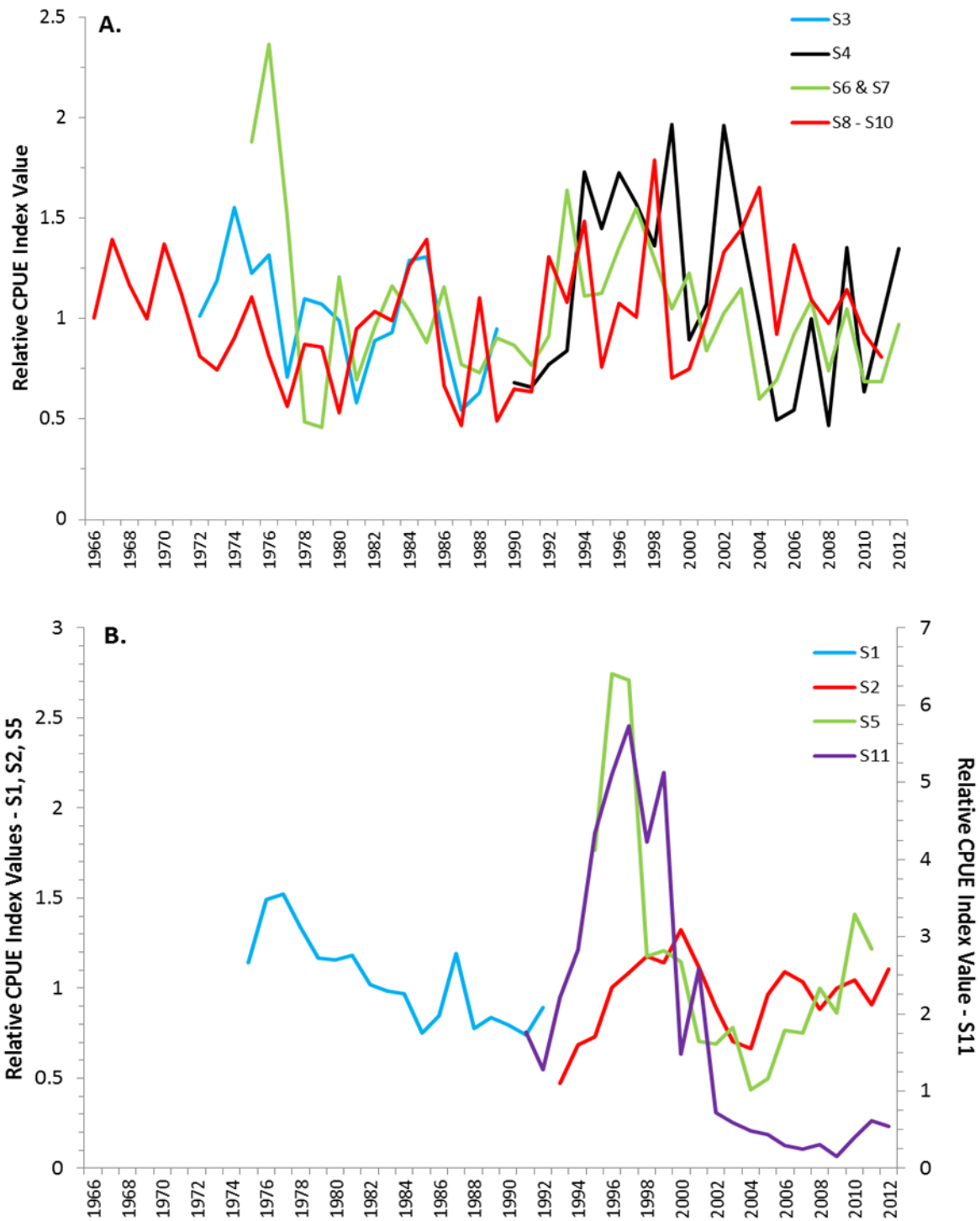

Figure 3.5. Comparison of trends in the primary juvenile (S3, S4, S6, S7, S8, S9, S10) abundance indices (A - top panel) and the primary adult (S1, S2, S5, S11) abundance indices (B - bottom panel) considered for the 2014 base case model. The values for each index are shown relative to the median of each time series to remove scaling effects. The base case model was fitted to S1, S2, S3, and S4. Note that indices S6 and S7 (JPLLS 1975-1988, 1989-2012) and indices S8-S10 (EPO 1966-1978, 1979-1998, 1999-2012) were standardized separately but are shown as one index for display purposes. See text and Table 3.3 for description of indices.

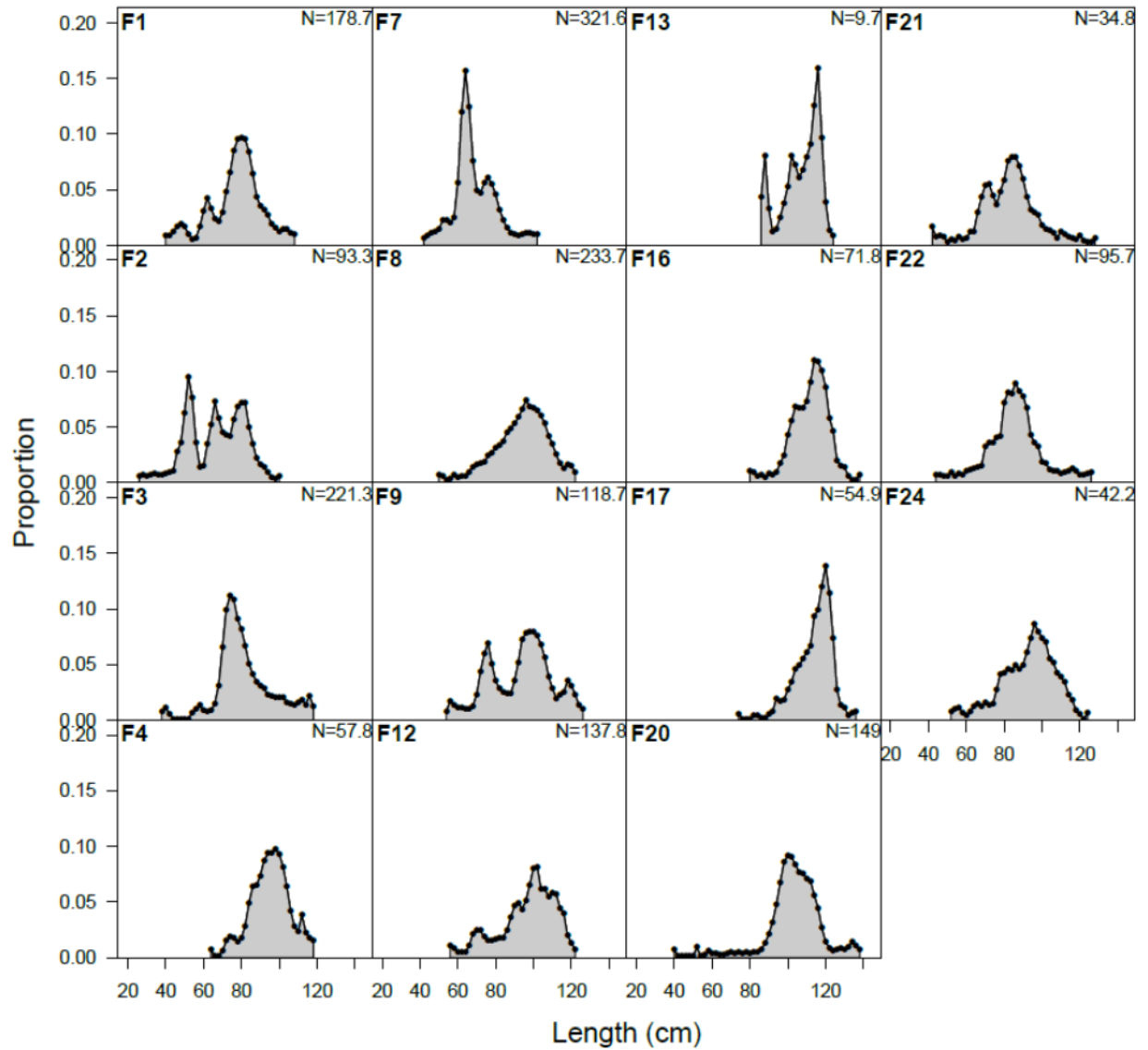

Figure 3.6. Observed proportions at length (FL) from fisheries for which size composition data are collected. Samples are aggregated across year and sex by fishery and season. See Table 3.1 for fishery descriptions. N is the input sample size for each fishery.

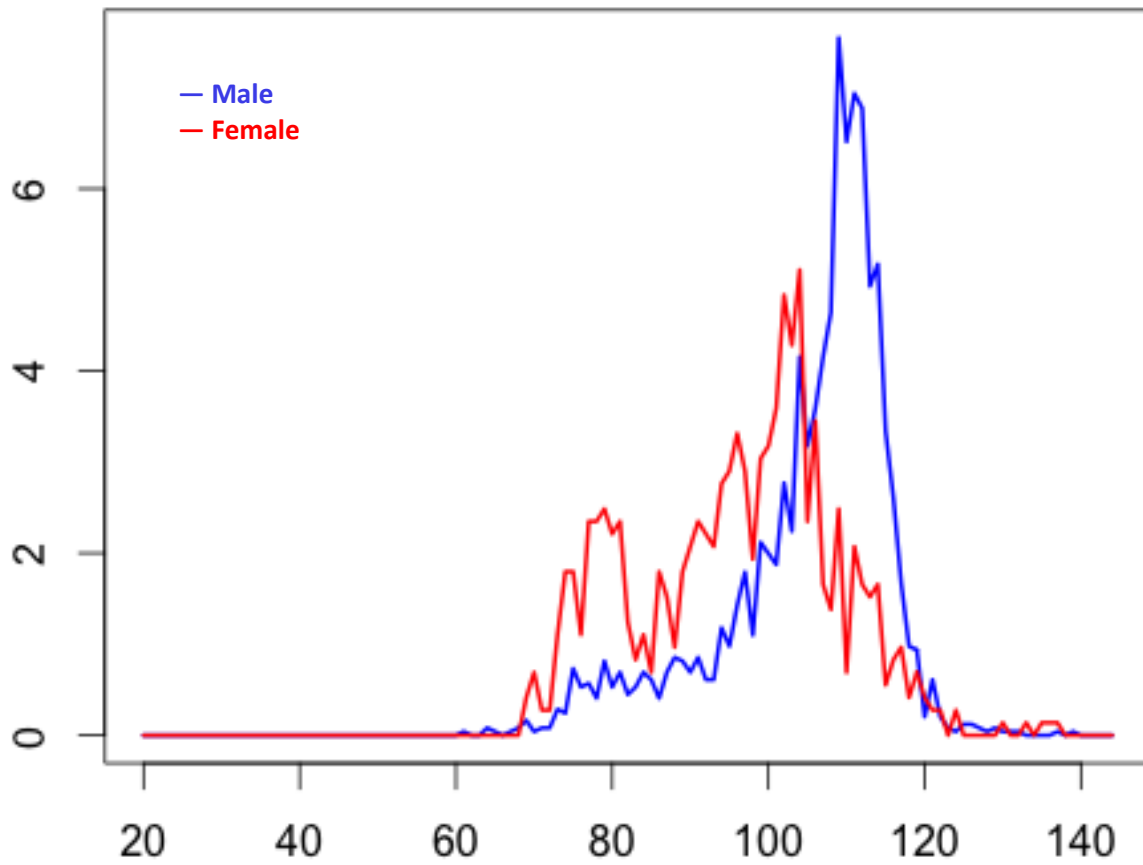

Figure 3.7. Proportion of males and females by length (fork length in cm) sampled in Japanese training vessel longline catches from 1987 to the present. Data are aggregated across years and fishing areas.

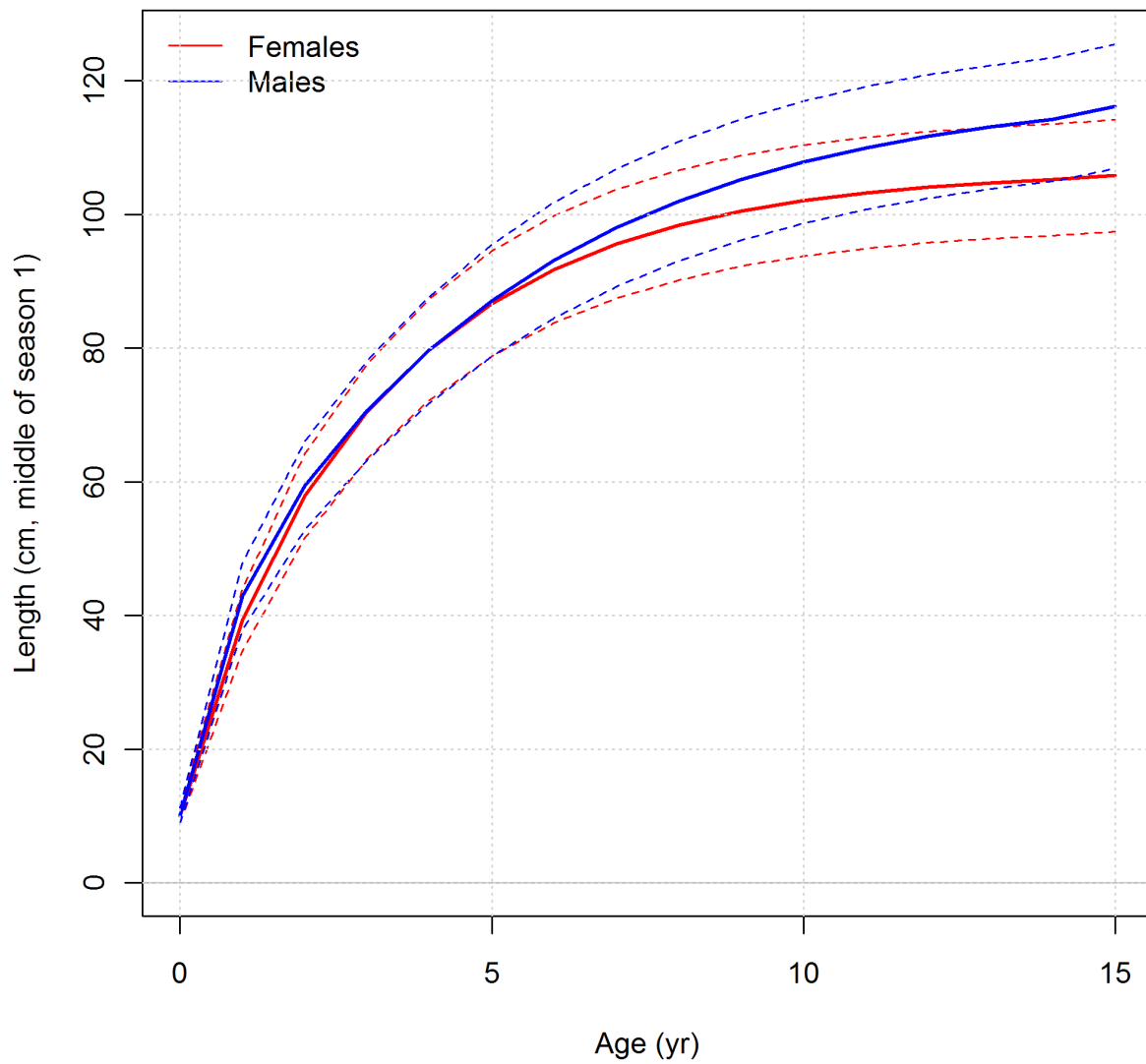

Figure 4.1. Growth model of north Pacific albacore used in the 2014 base case model. Dashed lines indicate 95% confidence intervals. Based on sex-specific growth model by Xu et al. (2014a). See Tables 4.1 and 4.2 for detailed parameters.

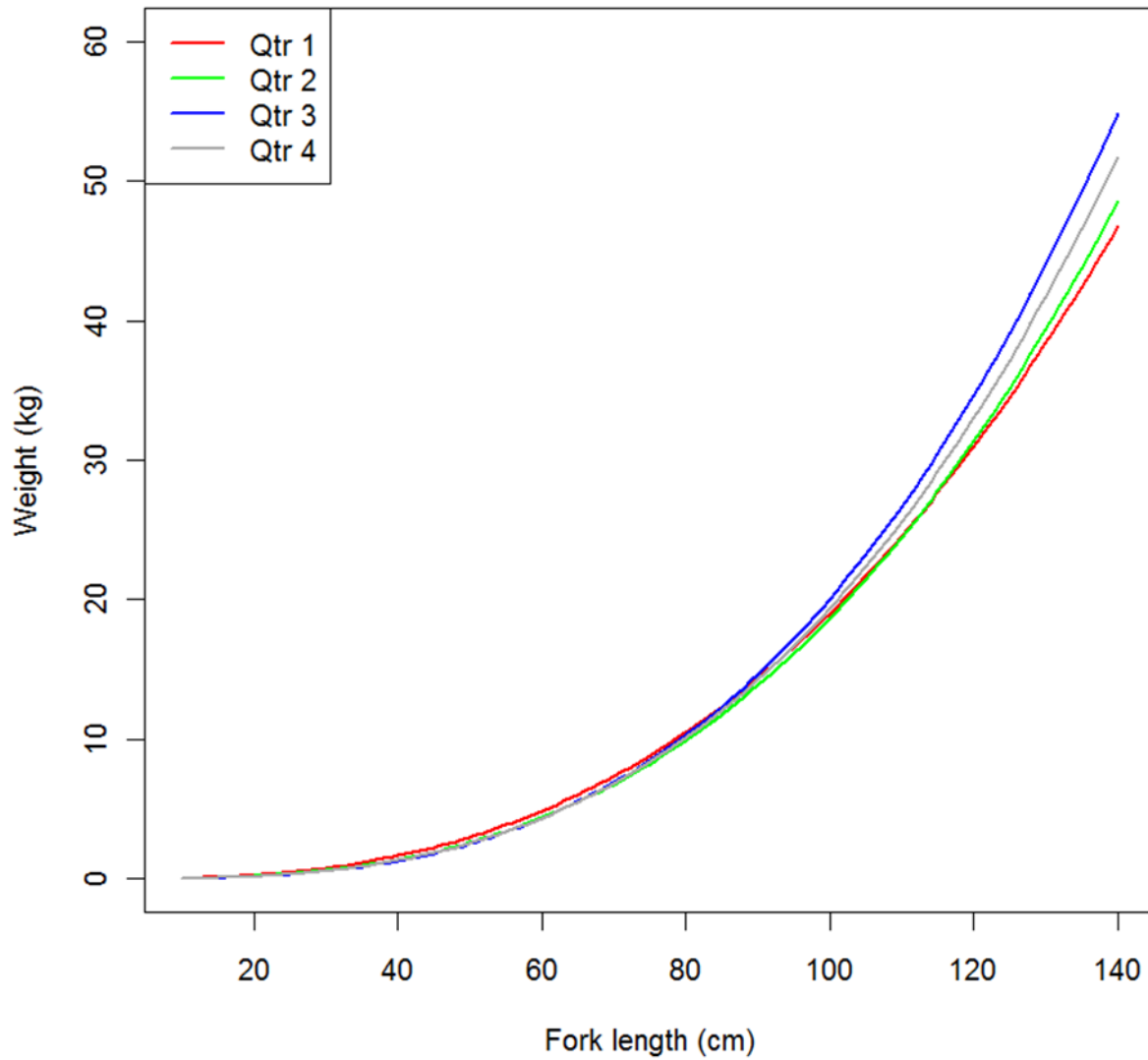

Figure 4.2. Seasonal weight at length relationships of north Pacific albacore used in the 2014 base case model. Based on Watanabe et al. (2006). Male weight-at-length relationships are assumed to be identical to female relationships. See Tables 4.1 for detailed parameters.

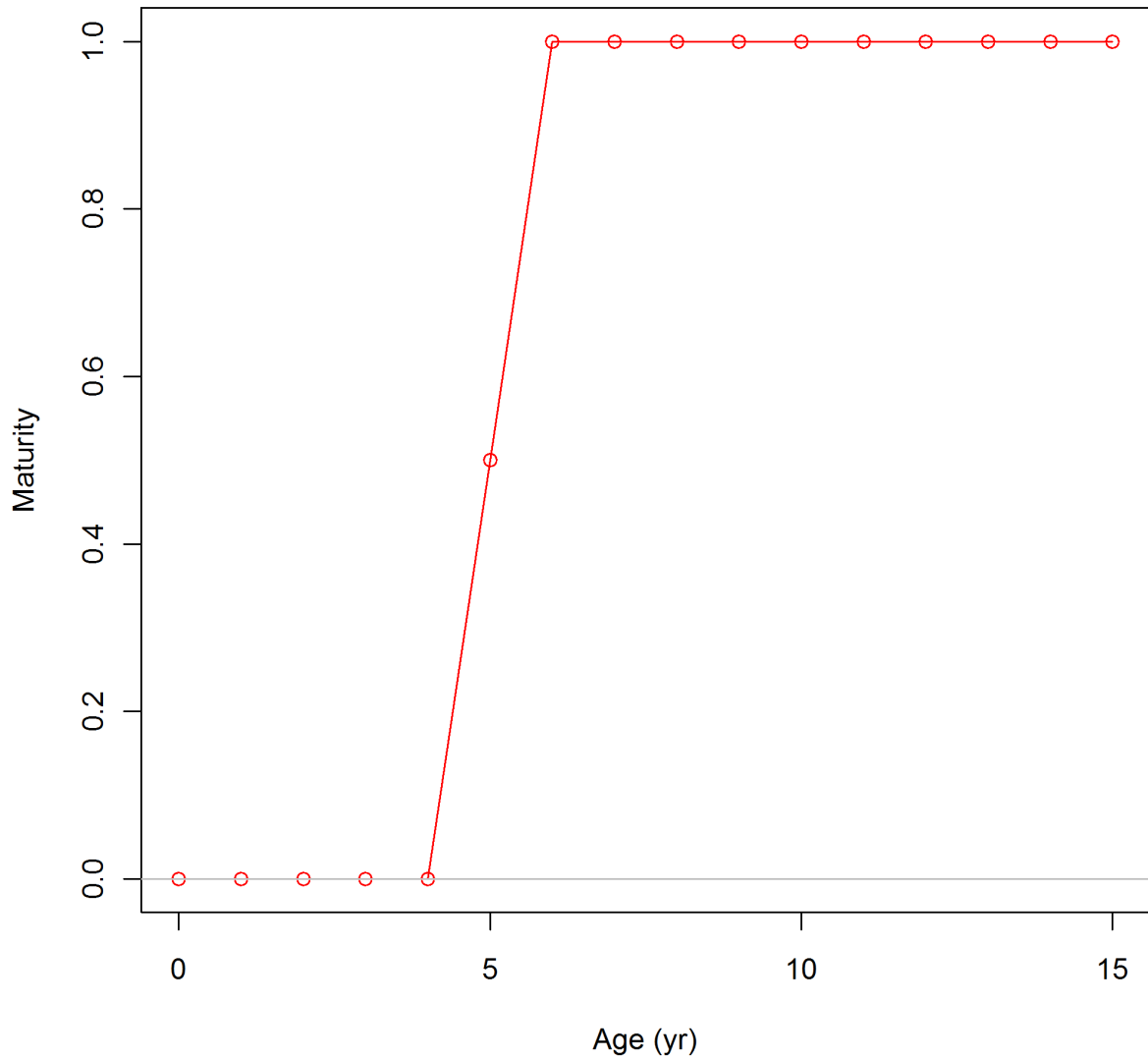

Figure 4.3. Maturity at age for female north Pacific albacore used in the 2014 base-case model. Based on Ueyanagi (1957). See Table 4.1 for detailed parameters.

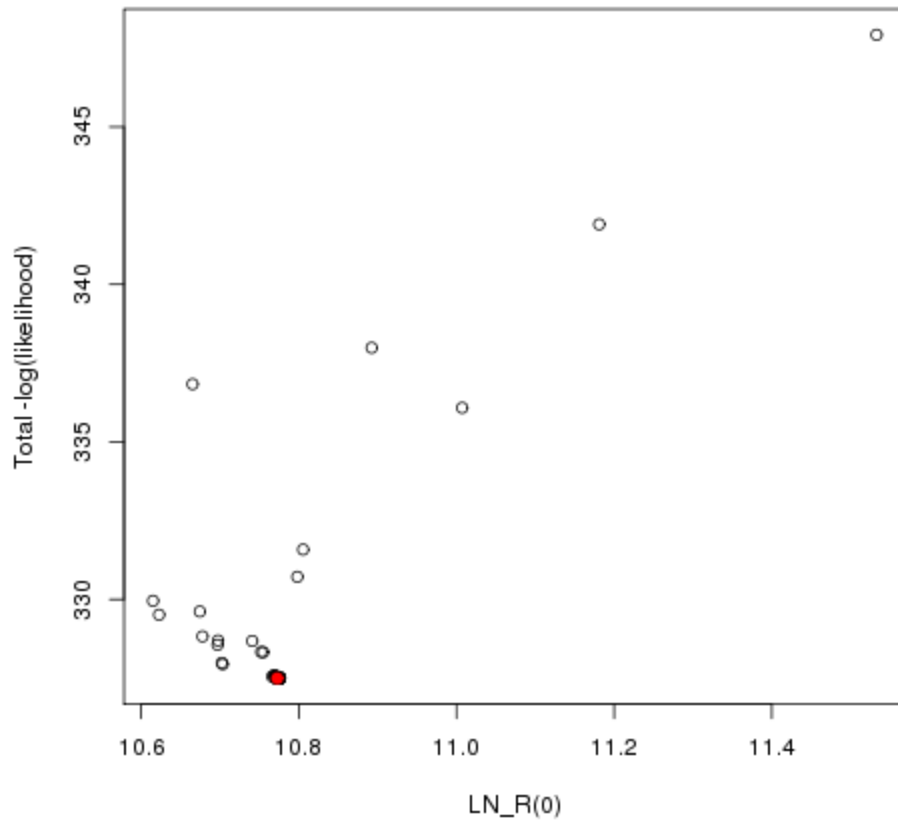

Figure 5.1. Total negative log-likelihood and estimated virgin recruitment in log-scale [$\ln(R_0)$] from 50 model runs with different phasing and initial values of $\ln(R_0)$ and other important parameters, as well as randomly jittered initial values for all estimated parameters in the base-case model. Red closed circle indicates results from model run using initial parameters and phasing from the 2014 base case model, which has the lowest total negative log-likelihood (-327.493) of all 50 model runs.

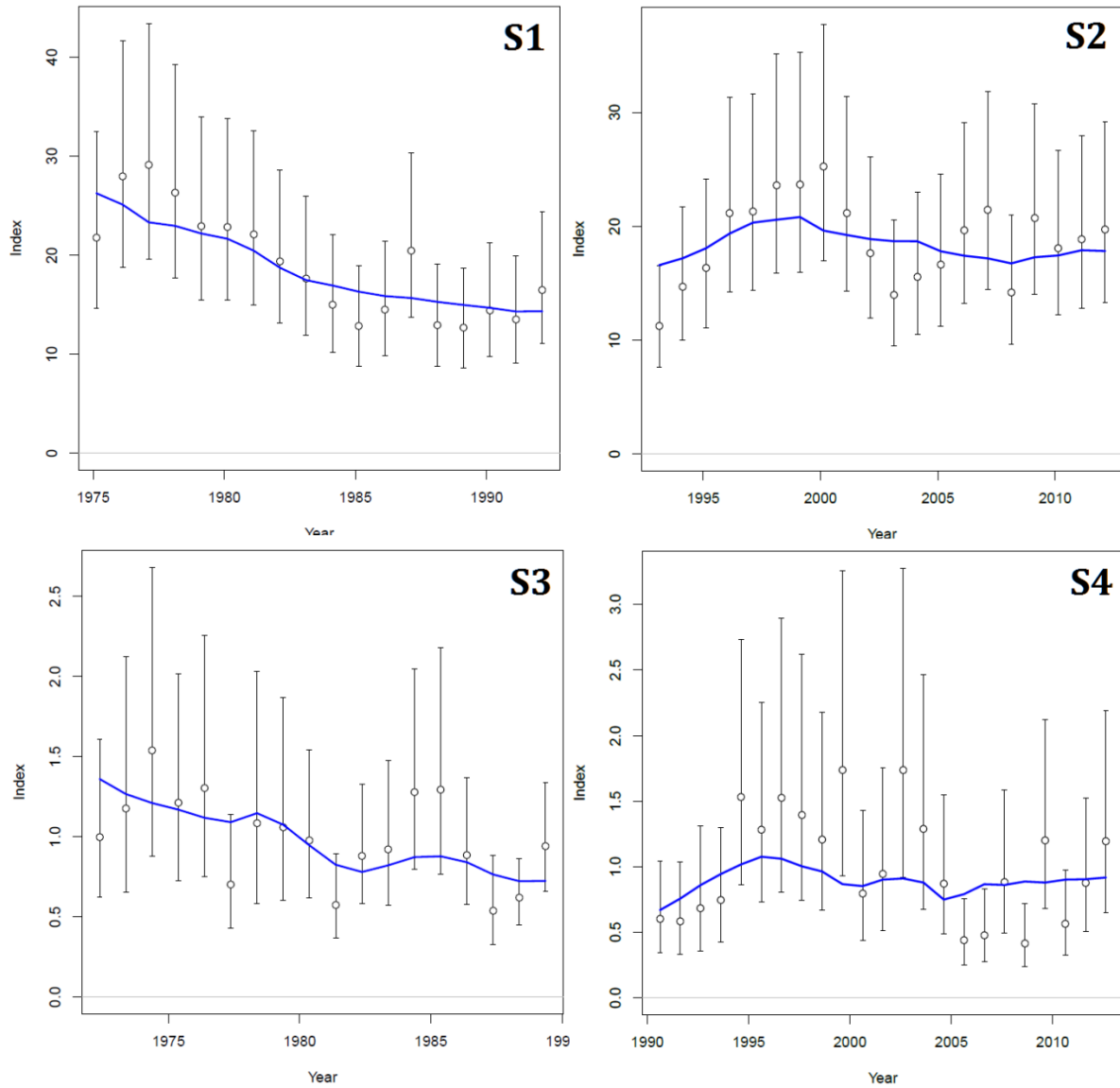

Figure 5.2. Observed (open circles) and predicted (blue line) relative abundance from adult (S1 and S2) and juvenile (S3 and S4) abundance indices in the 2014 base case model. Error bars indicate 95% confidence intervals.

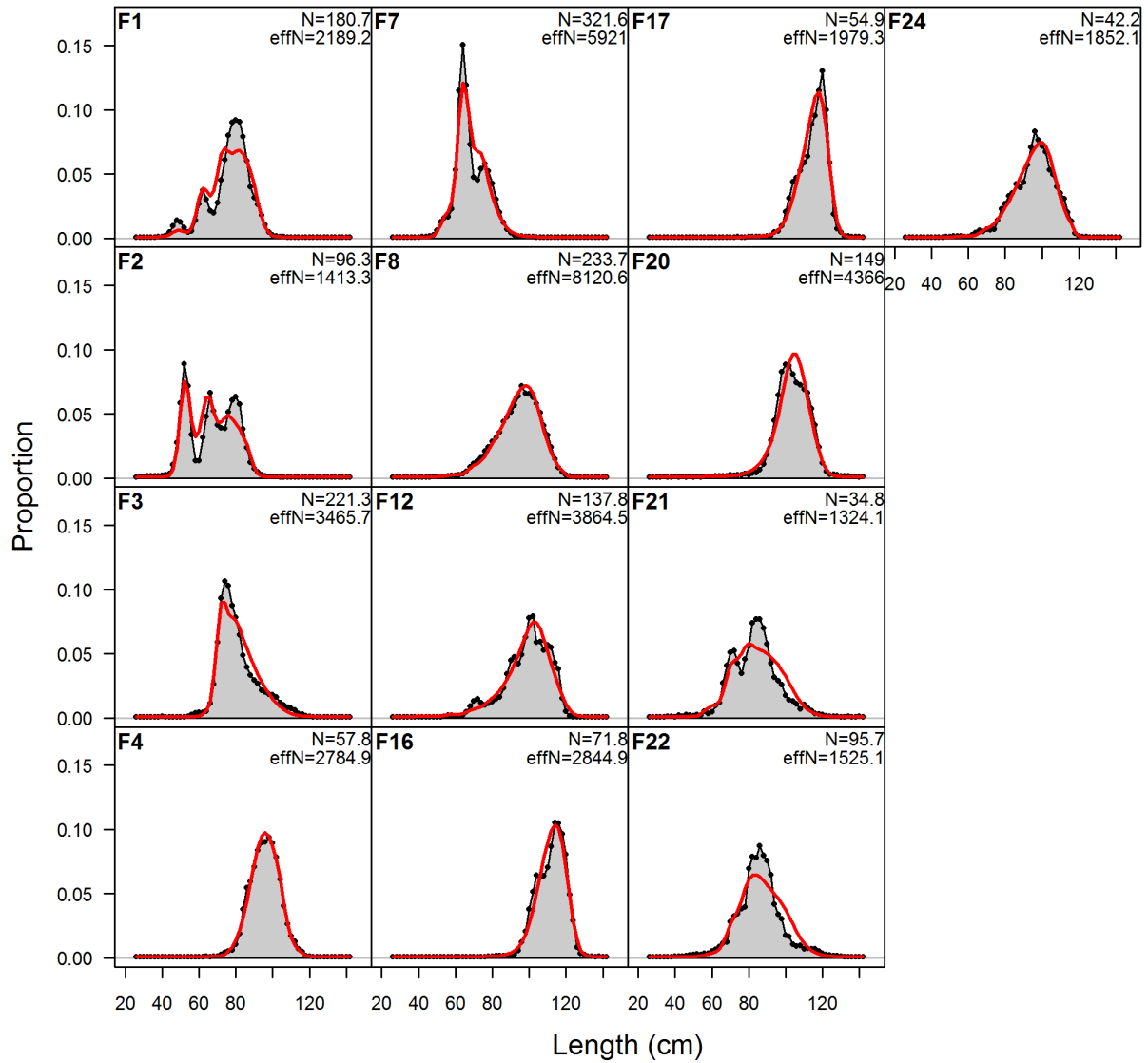

Figure 5.3. Observed (grey) and model predicted (red line) overall size compositions for fisheries in the 2014 base-case model. Only fisheries with size composition data fitted in the model are shown.

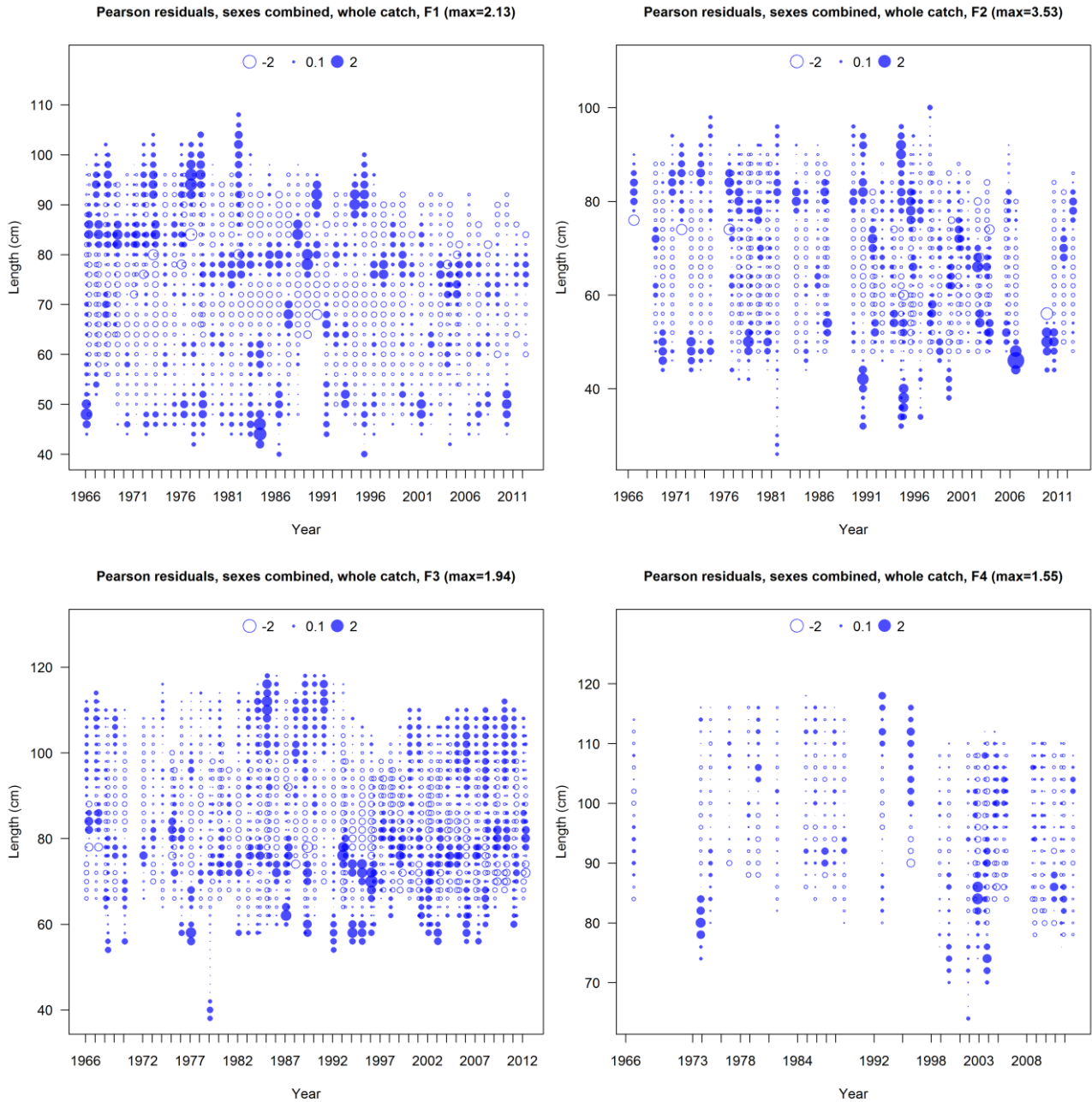

Figure 5.4. Pearson residuals of model fit to size composition data from fisheries in the 2014 base-case model. Filled and open circles represent observations (i.e., proportions at size) that are larger and smaller than model predictions, respectively. Area of circles are proportional to absolute values of residuals. Only fisheries with size composition data fitted in the model are shown.

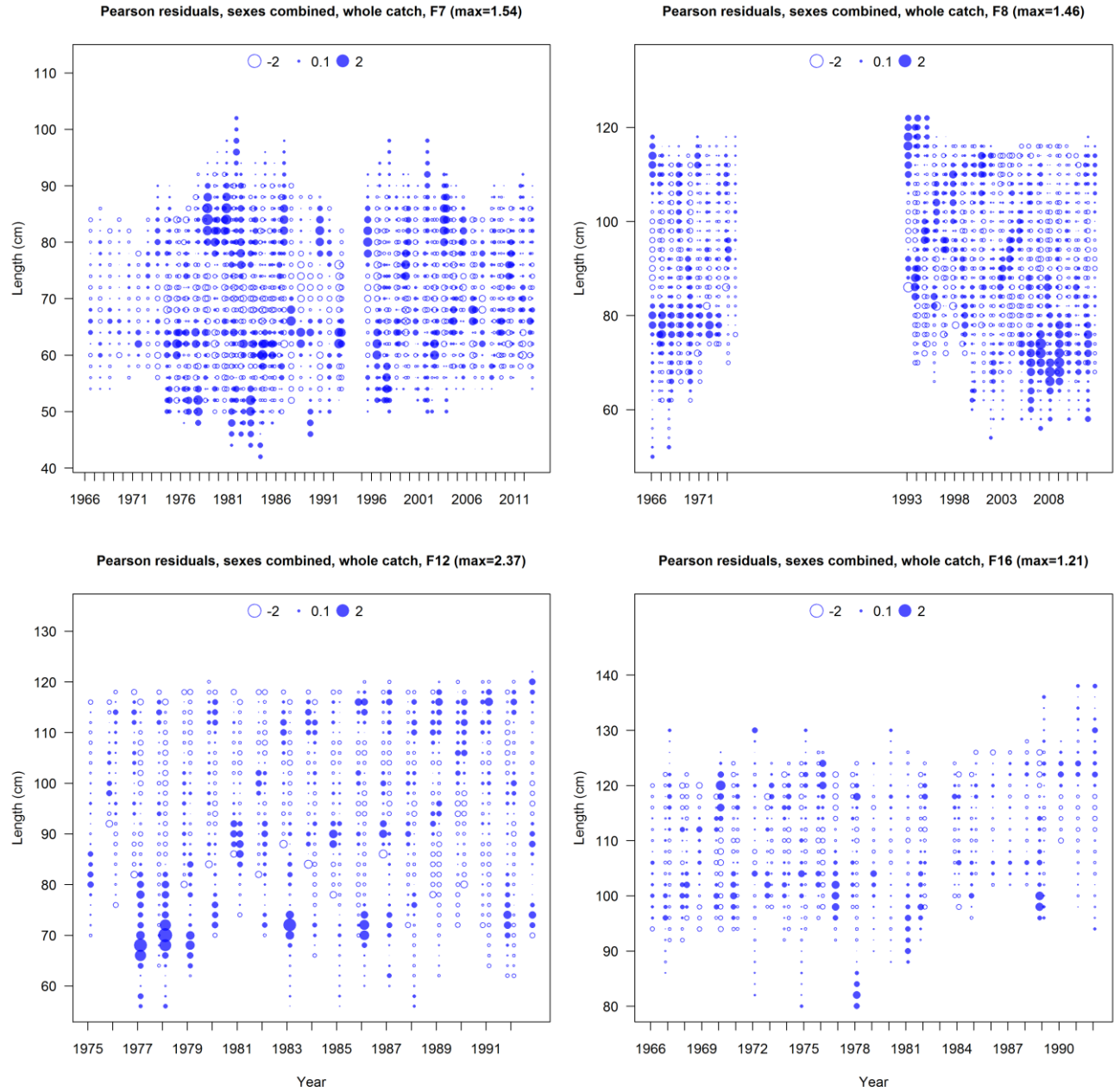

Figure 5.4. Continued.

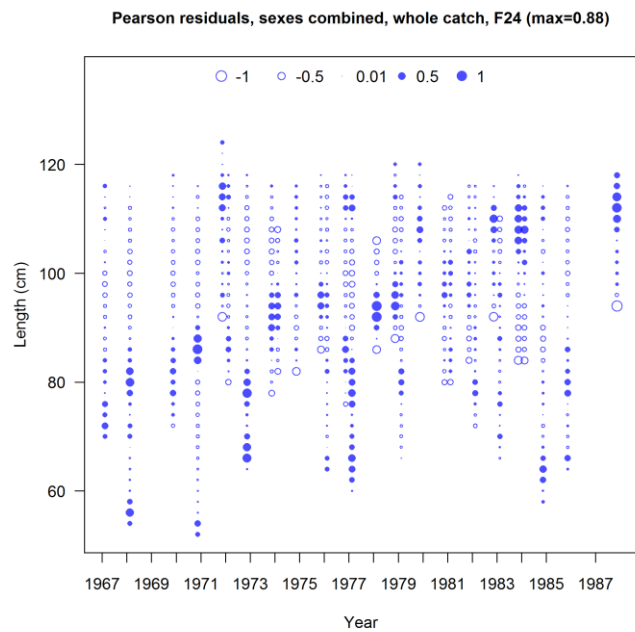
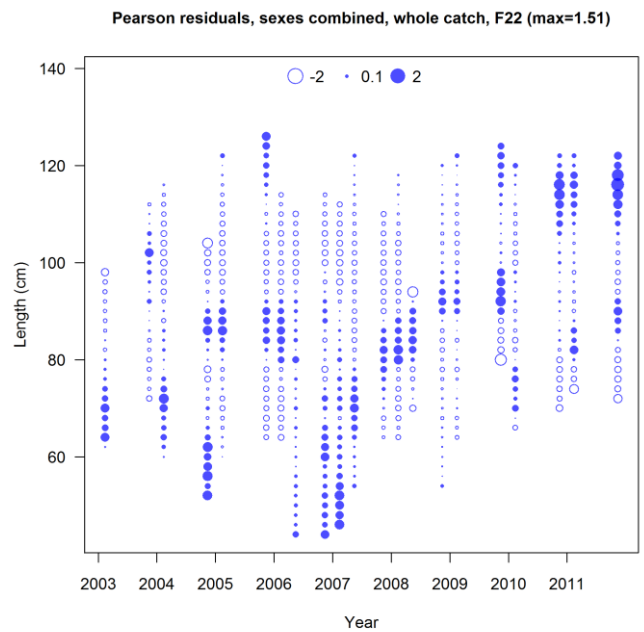
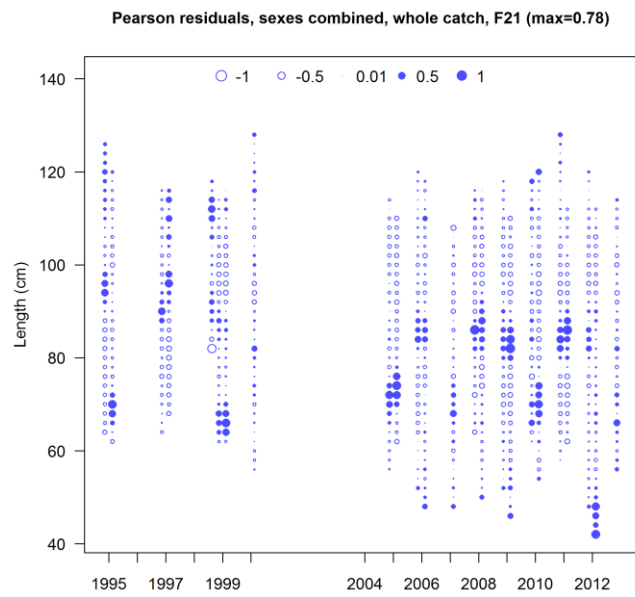
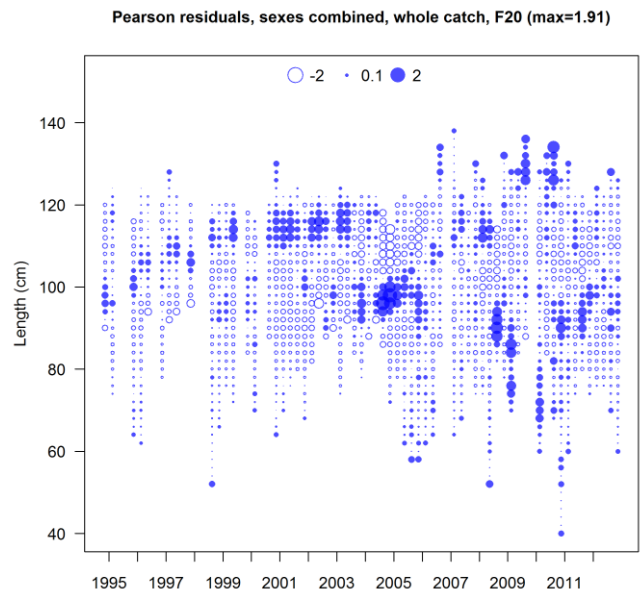
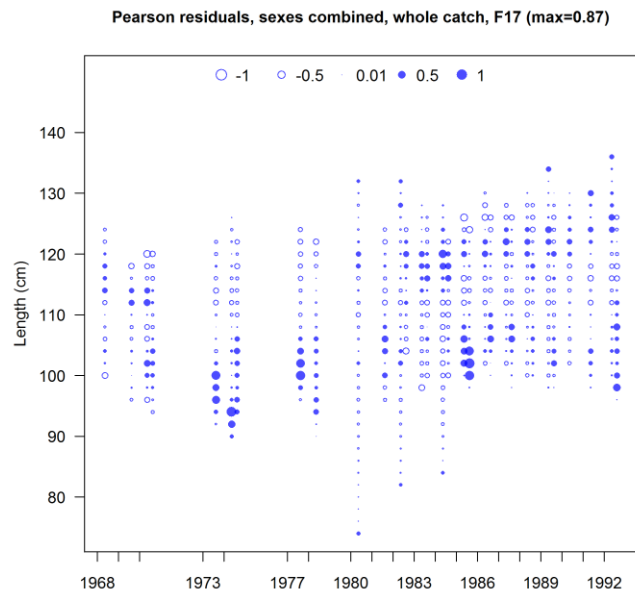

Figure 5.4. continued.

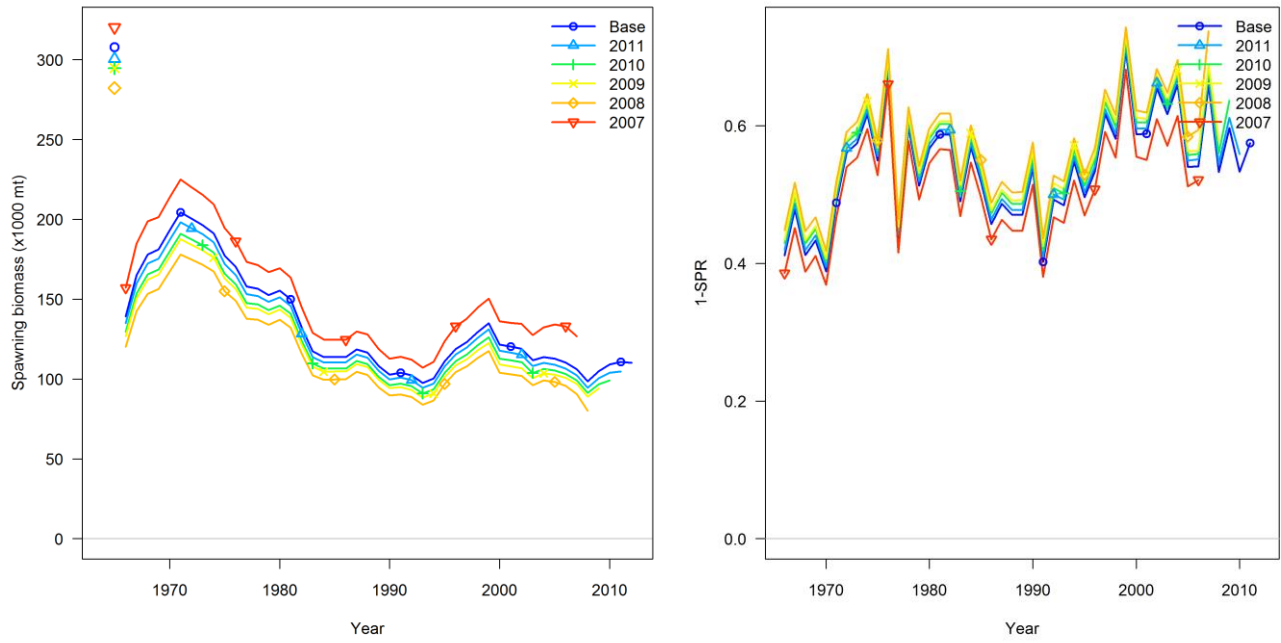

Figure 5.5. Five year retrospective analyses of female north Pacific albacore spawning biomass and fishing intensity (1-SPR) for the 2014 base-case model. Colors indicate different ending year of the retrospective models, with the base model ending in 2012.

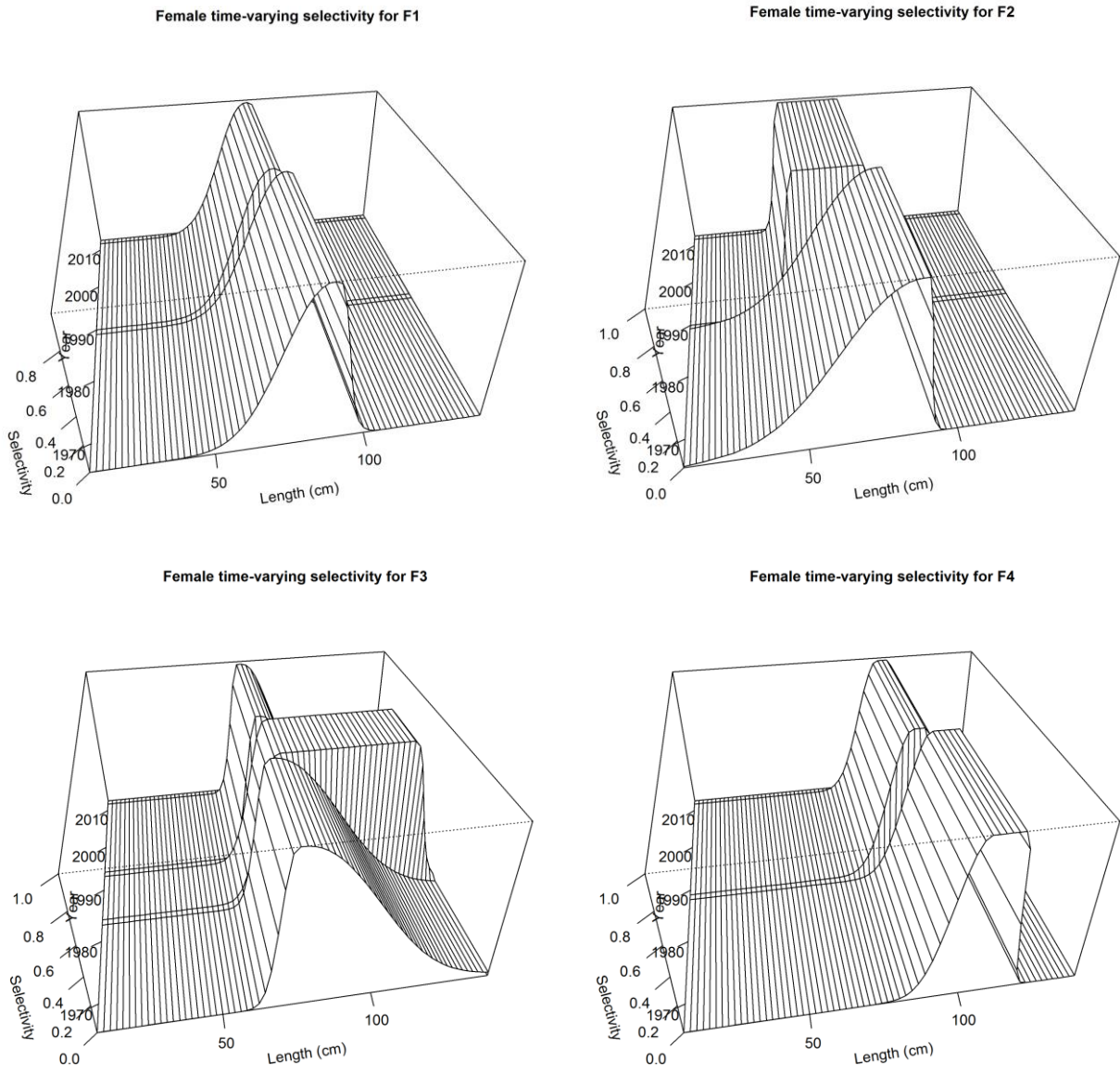
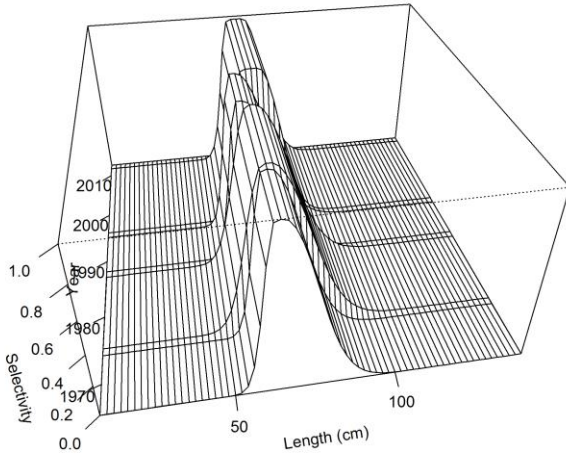
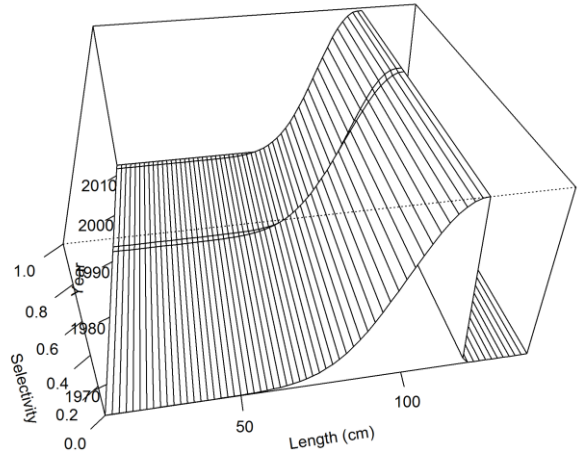

Figure 5.6. Size selectivity for fisheries estimated in the 2014 base-case model. Selectivity patterns are displayed as 3-dimensional plots to show time-varying selectivity. Male selectivity is identical to female selectivity in the base-case model. Only fisheries with size composition data fitted in the model are shown.

Female time-varying selectivity for F7



Female time-varying selectivity for F8



Female ending year selectivity for F12

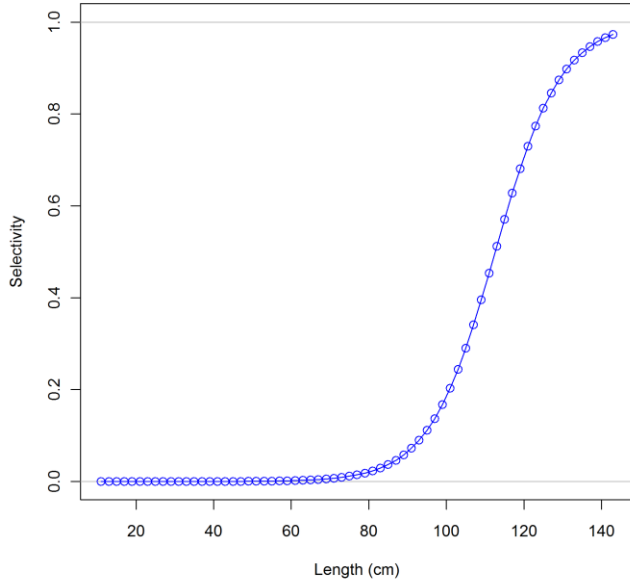

Female time-varying selectivity for F16

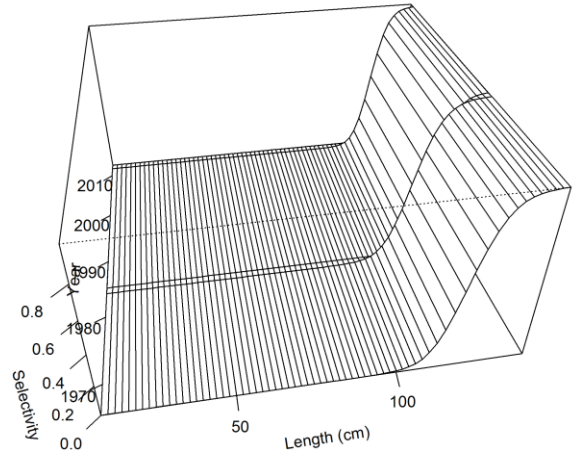
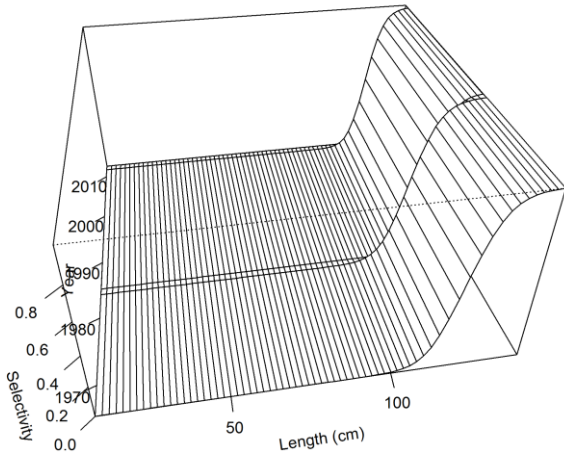
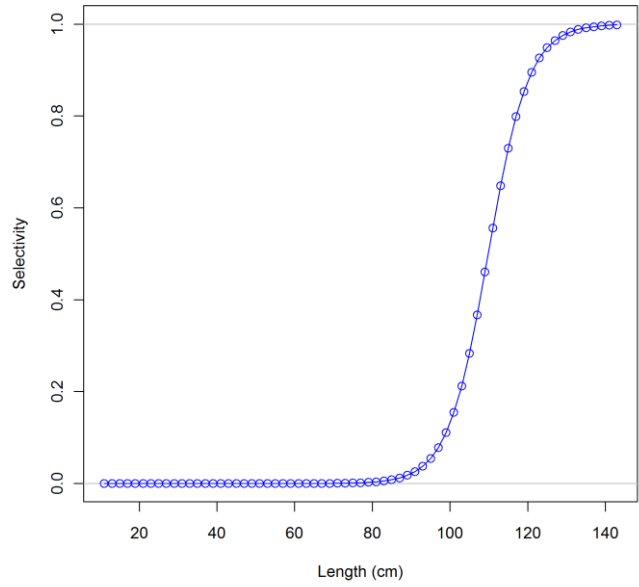

Figure 5.6. continued.

Female time-varying selectivity for F17



Female ending year selectivity for F20



Female time-varying selectivity for F21

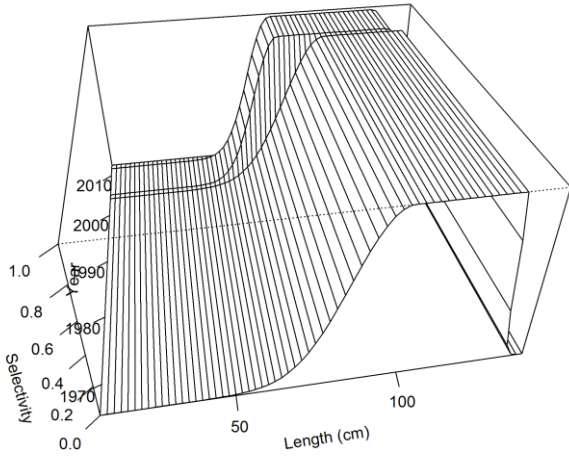

Female ending year selectivity for F22

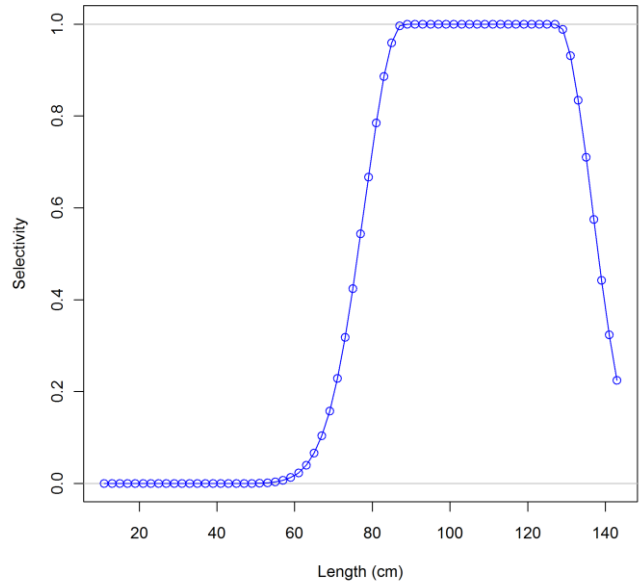

Female ending year selectivity for F24

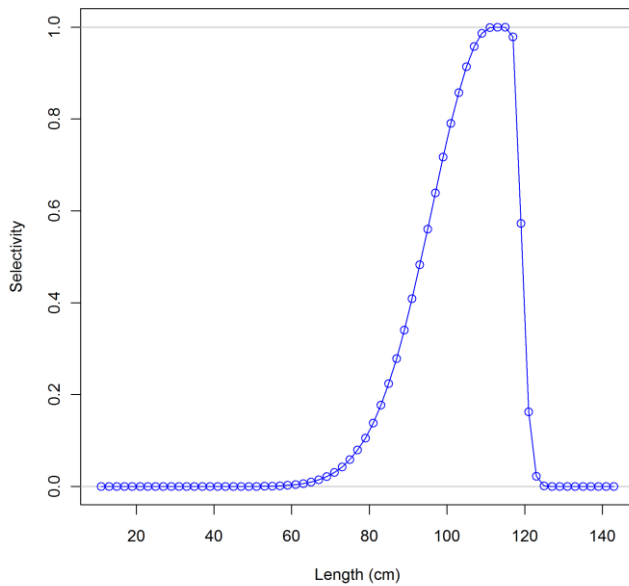

Figure 5.6. continued.

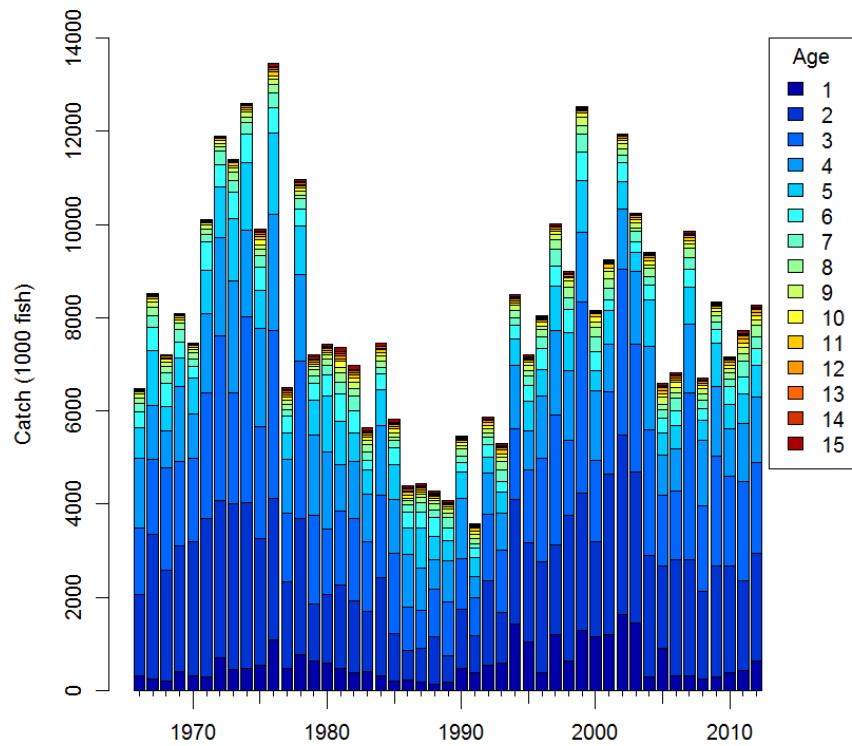

Figure 5.7. Historical catch-at-age (numbers of fish) estimated by the 2014 base-case model. The assessment model was parameterized with 15 age classes based on the oldest observed age of 15 years.

Sex ratio of numbers at age (males/females)

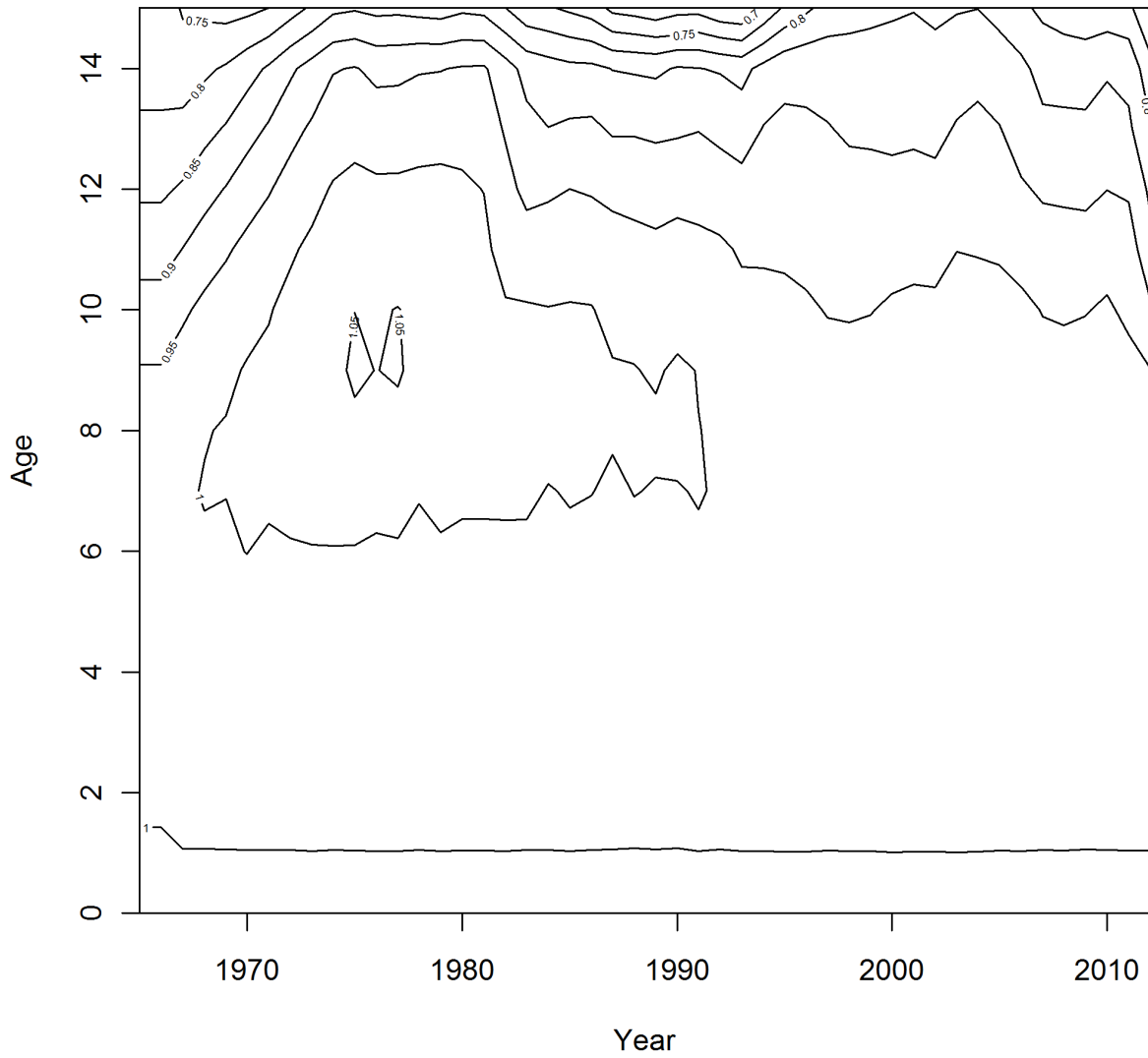

Figure 5.8. Sex ratio (male/female) of numbers at age estimated in the 2014 base-case model.

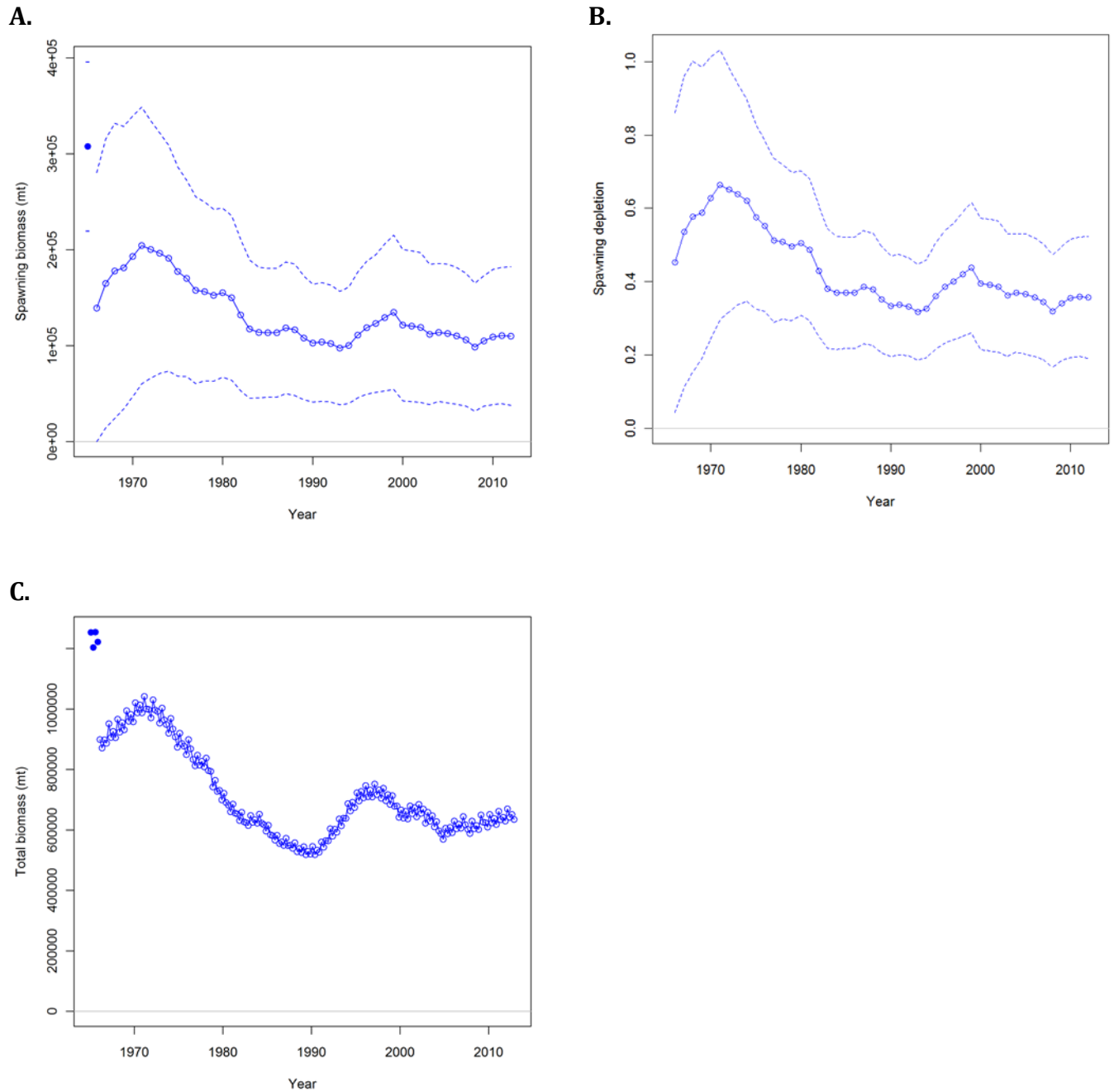

Figure 5.9. Estimated female spawning biomass (A), spawning depletion (SSB/SSB_0) (B), and seasonal total biomass (age-1+) (C) of the 2014 base-case model. Dashed lines indicate 95% confidence intervals and closed circle and error bars in upper panel indicate estimated virgin spawning biomass (SSB_0) and 95% confidence intervals respectively. Total biomass is estimated quarterly so there are four estimates per year (C) whereas female spawning stock biomass (A) is only estimated once annually at the beginning of the second quarter (spawning season).

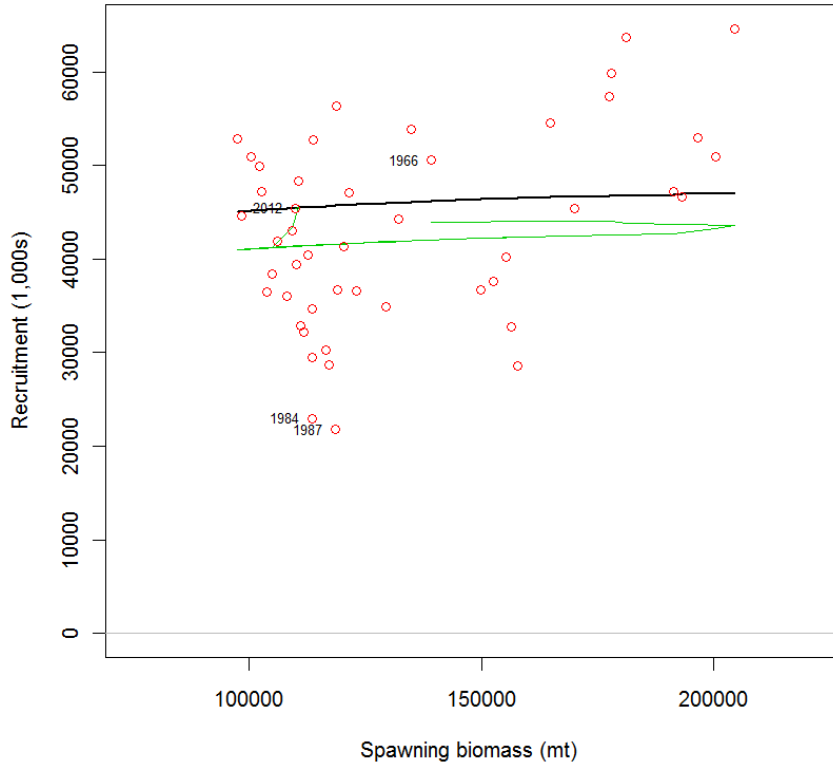

Figure 5.10. Spawning stock-recruitment curve in the 2014 base-case model. Red open circles indicate estimated recruitment. Black line indicates expected recruitment (i.e., from stock-recruitment relationship) and green line indicates expected recruitment after bias adjustment due to the lack of information on recruitment in the early and late periods. Year labels indicate the initial and final years, as well as years with recruitment deviations larger than the σ_R of 0.5.

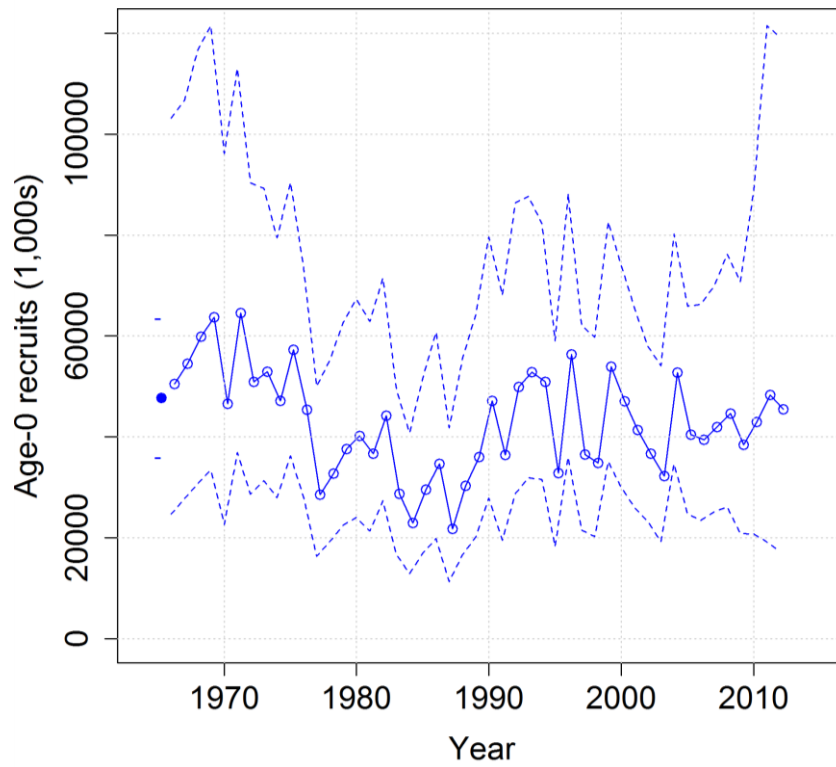

Figure 5.11. Estimated recruitment of the 2014 base-case model. Dashed lines indicate 95% confidence intervals and closed circle and error bars in upper panel indicate estimated virgin recruitment (R_0) and 95% confidence intervals respectively.

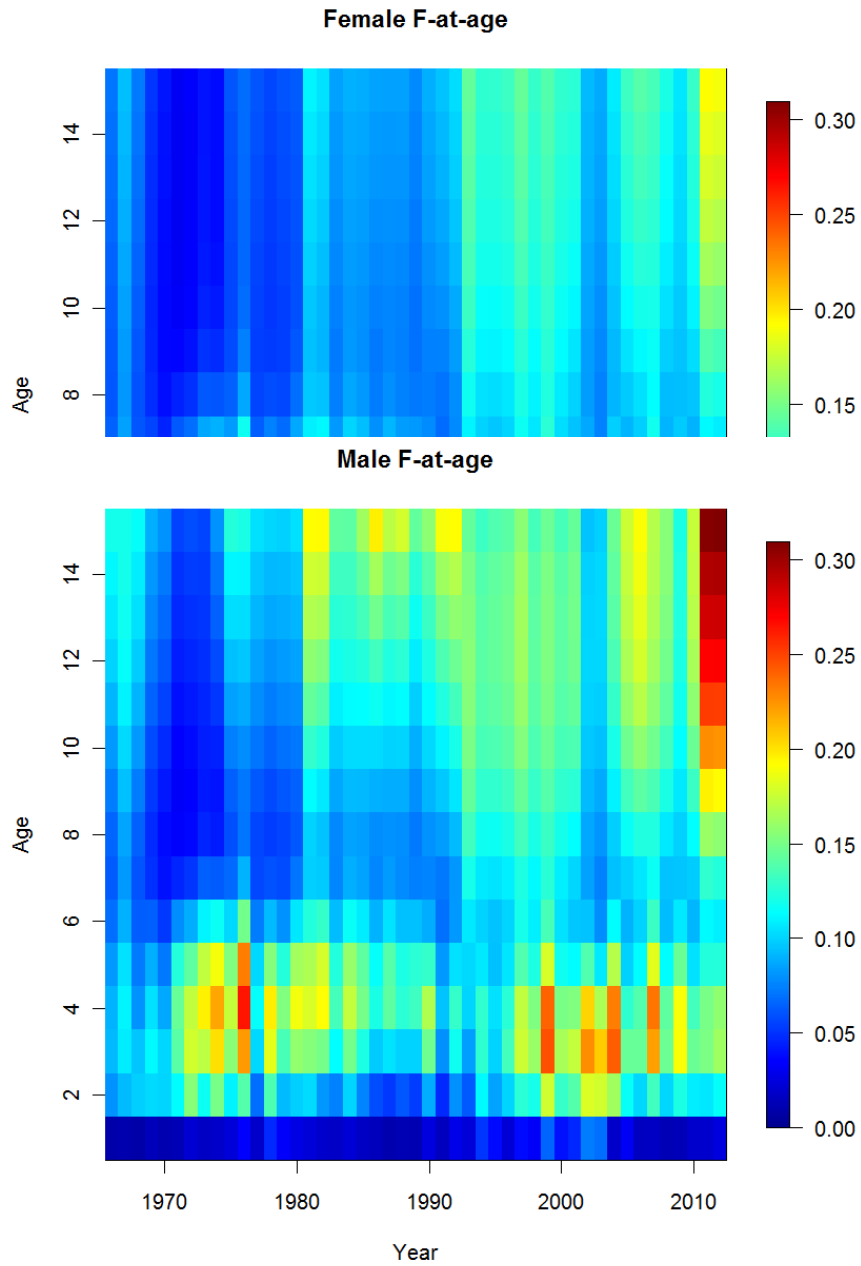

Figure 5.12. Fishing mortality at age (F-at-age) estimated in the 2014 base-case model for female (top) and male (bottom) north Pacific albacore tuna. Both panels are on the same scale.

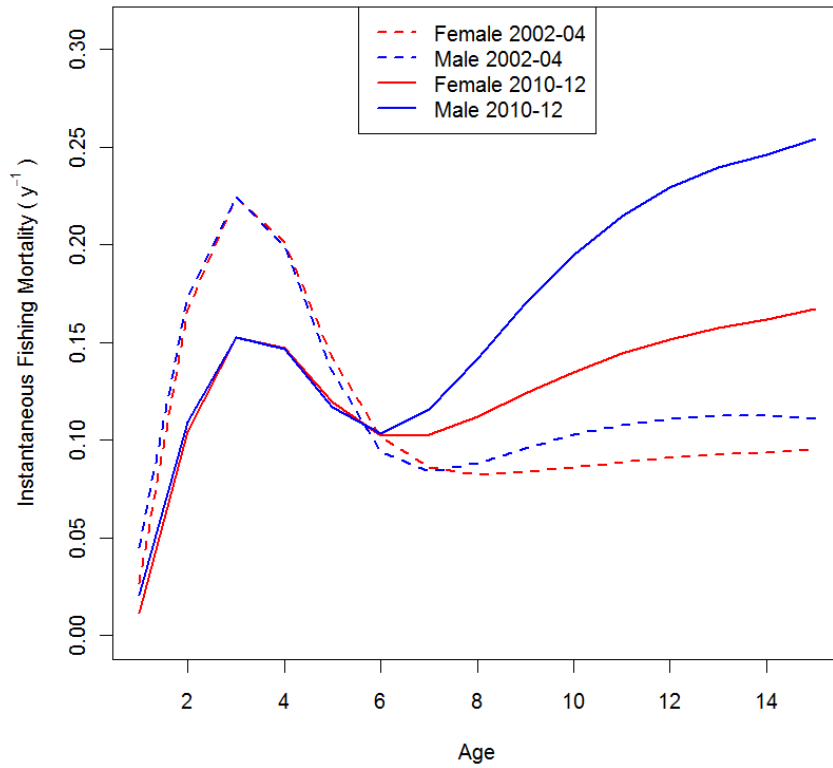

Figure 5.13. Estimated instantaneous fishing mortality at age for the last 3 years of the 2014 base-case model (current F ; $F_{2010-2012}$) and $F_{2002-2004}$ (reference years for current management measures). The F s for the periods were calculated as the geometric mean of the F s for each year within the period.

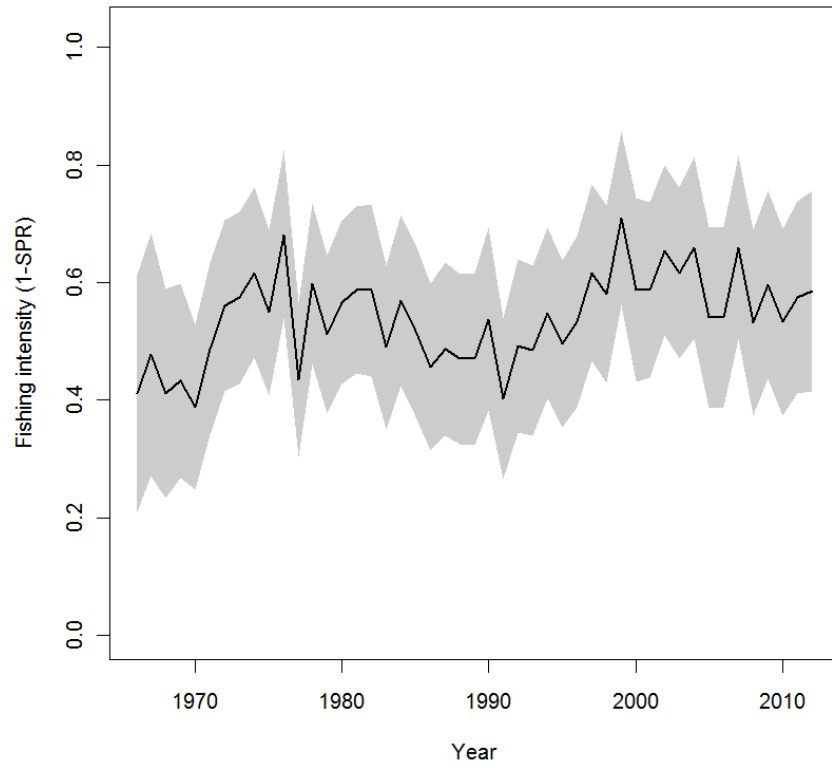

Figure 5.14. Estimated fishing intensity (1-SPR) from the 2014 base-case model. Black line indicate maximum likelihood estimate while grey area indicate 95% confidence intervals.

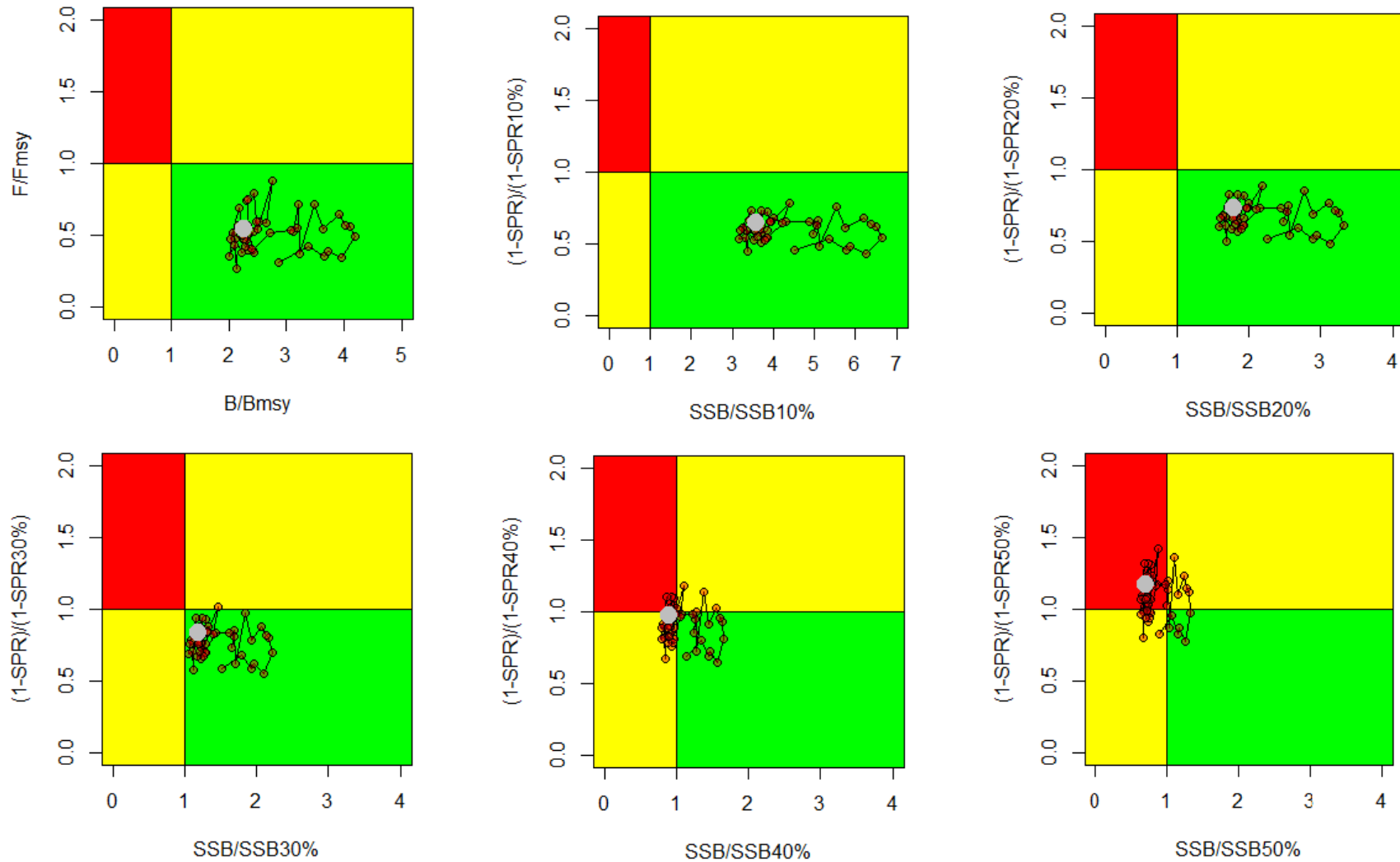

Figure 5.15. Alternative Kobe plots showing north Pacific albacore (*Thunnus alalunga*) stock status based on $F_{current}$ ($F_{2010-2012}$) relative to MSY-based reference points (top left) and MSY proxies consisting of SPR-based fishing intensity reference points ($F_{10\%-50\%}$) for the 2014 base case model. Grey dots are the terminal year of the assessment (2012). These plots are presented for illustrative purposes since reference points have not been established for the north Pacific albacore stock. See the text of the assessment report regarding comments on the interim reference point $F_{SSB-ATHL}$.

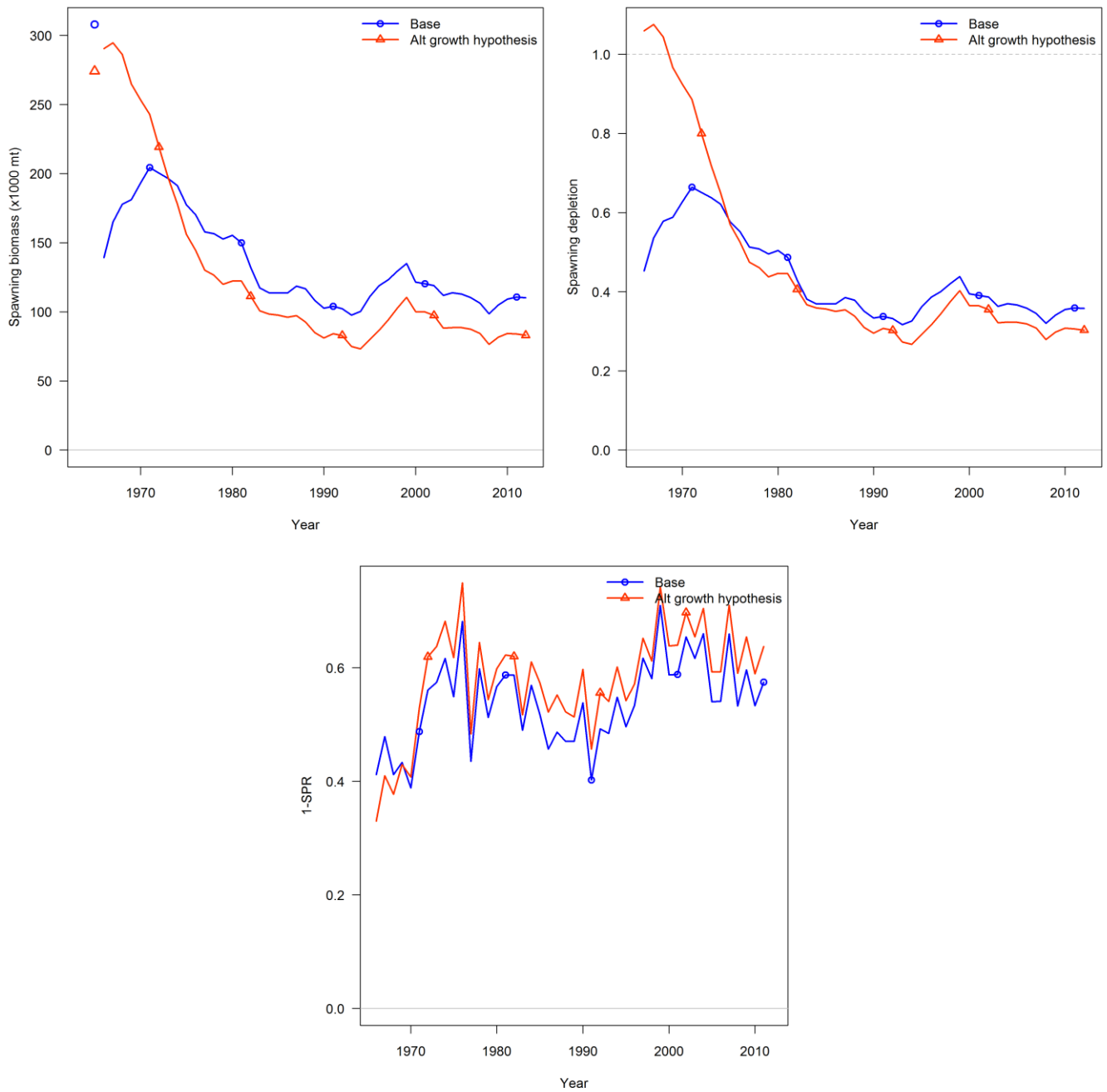

Figure 5.16. Estimated spawning biomass (upper left), spawning depletion (upper right), and fishing intensity (1-SPR) (lower) for the 2014 base-case model (blue) and a sensitivity run using the alternative growth hypothesis (Sensitivity 01 - Growth hypothesis 1). See Table 4.5 for details on sensitivity runs.

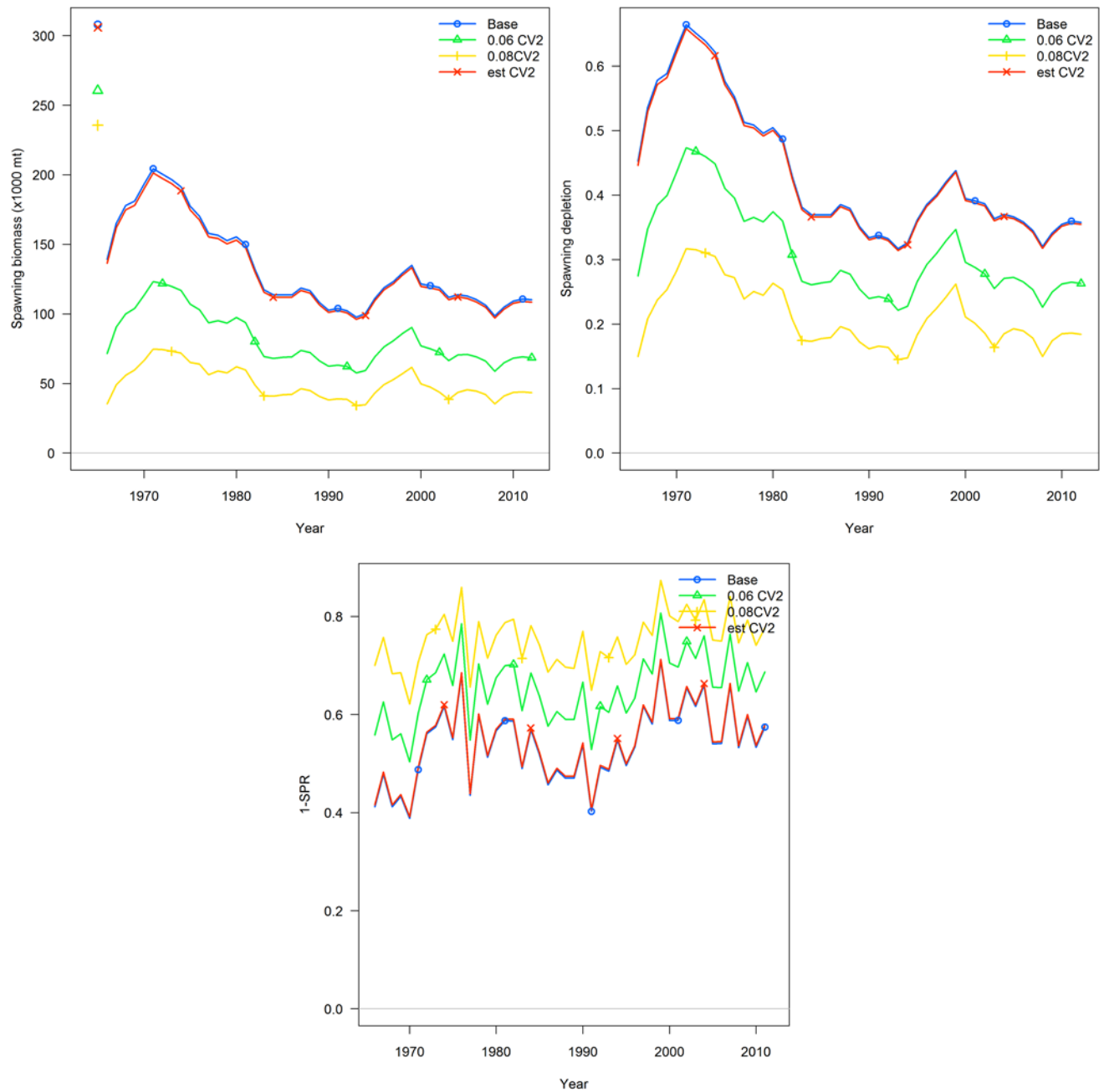

Figure 5.17. Estimated spawning biomass (upper left), spawning depletion (upper right), and fishing intensity (1-SPR) (lower) for the base-case model (blue) and sensitivity runs using different CVs of L_{inf} (Sensitivity 02 – CV of L_{inf}). See Table 4.5 for details on sensitivity runs. Total negative log-likelihoods for the four runs are: Base – 327.493; 0.06 CV2 – 329.421; 0.08 CV2 – 333.435; and est CV2 – 327.488.

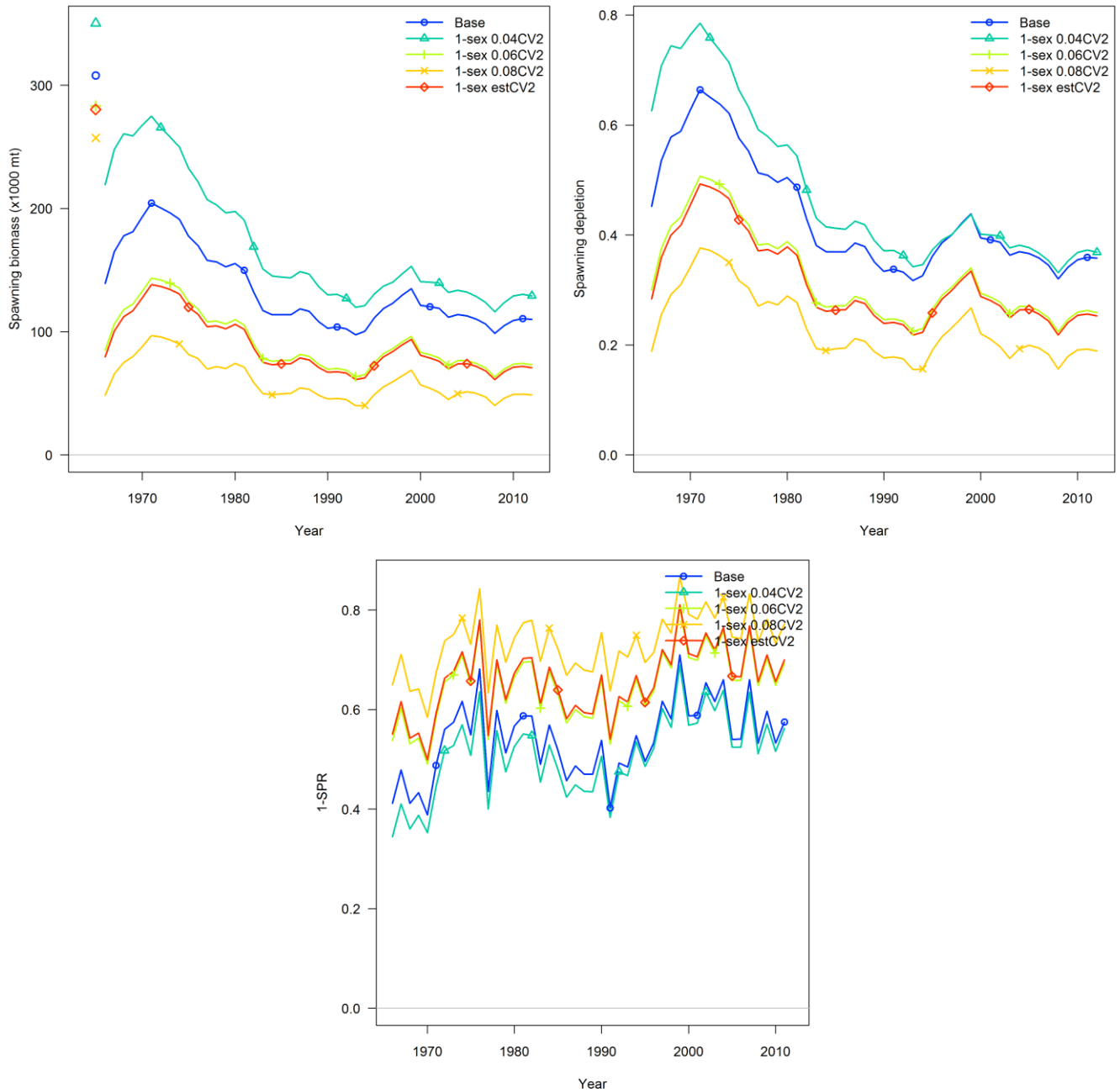

Figure 5.18. Estimated spawning biomass (upper left), spawning depletion (upper right), and fishing intensity (1-SPR) (lower) for the 2014 base-case model (blue) and sensitivity runs using non sex-specific growth model with different CVs of L_{inf} (Sensitivity 03 – non sex-specific growth). See Table 4.5 for details on sensitivity runs. Total negative log-likelihoods for the five runs are: Base – 327.493; 1-sex 0.04 CV2 – 342.168; 1-sex 0.06 CV2 – 327.417; 1-sex 0.08 CV2 – 330.12; and 1-sex est CV2 – 327.39.

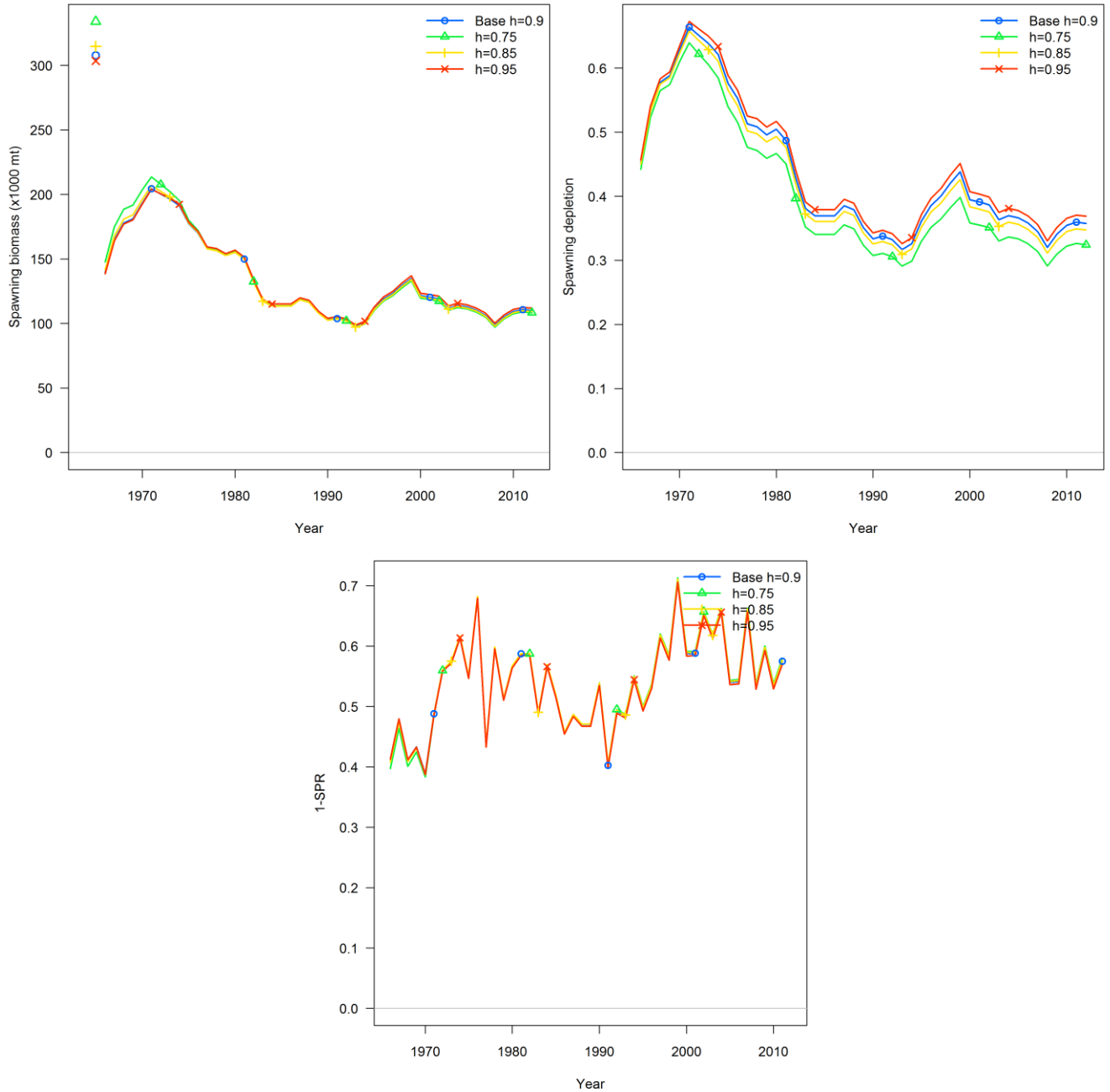

Figure 5.19. Estimated spawning biomass (upper left), spawning depletion (upper right), and fishing intensity (1-SPR) (lower) for the 2014 base-case model (blue) and sensitivity runs using different stock-recruitment steepness (h) values (Sensitivity 04 – steepness). See Table 4.5 for details on sensitivity runs. Total negative log-likelihoods for the four runs are: Base $h=0.9$ – 327.493; $h=0.75$ – 327.074; $h=0.85$ – 327.359; and $h=0.95$ – 327.617.

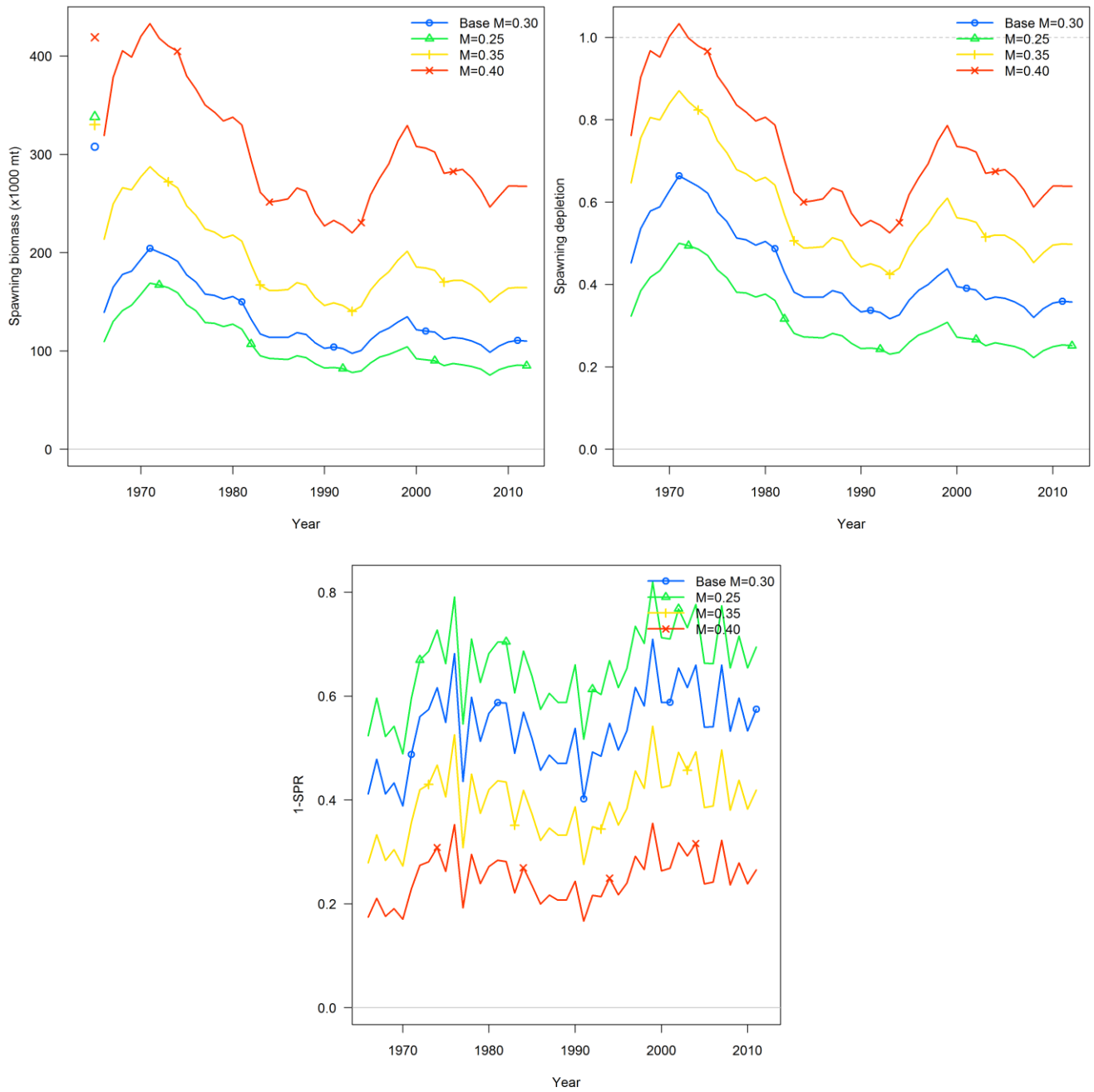

Figure 5.20. Estimated spawning biomass (upper left), spawning depletion (upper right), and fishing intensity (1-SPR) (lower) for the 2014 base-case model (blue) and sensitivity runs using different natural mortality (M) values (Sensitivity 05 – natural mortality). See Table 4.5 for details on sensitivity runs. Total negative log-likelihoods for the four runs are: Base M=0.30 – 327.493; M=0.25 – 327.667; M=0.35 – 327.363; and M=0.40 – 327.211.

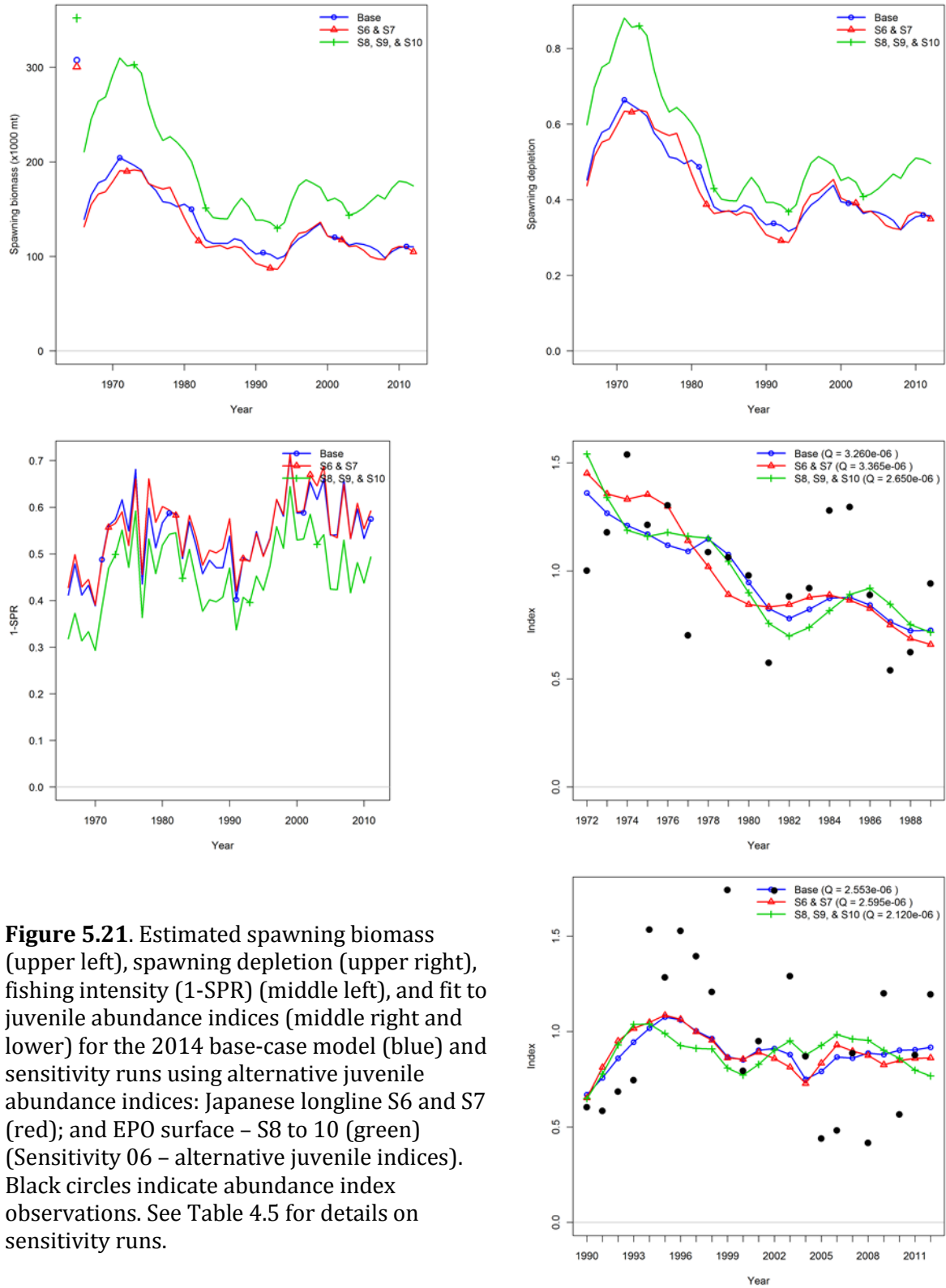

Figure 5.21. Estimated spawning biomass (upper left), spawning depletion (upper right), fishing intensity (1-SPR) (middle left), and fit to juvenile abundance indices (middle right and lower) for the 2014 base-case model (blue) and sensitivity runs using alternative juvenile abundance indices: Japanese longline S6 and S7 (red); and EPO surface – S8 to 10 (green) (Sensitivity 06 – alternative juvenile indices). Black circles indicate abundance index observations. See Table 4.5 for details on sensitivity runs.

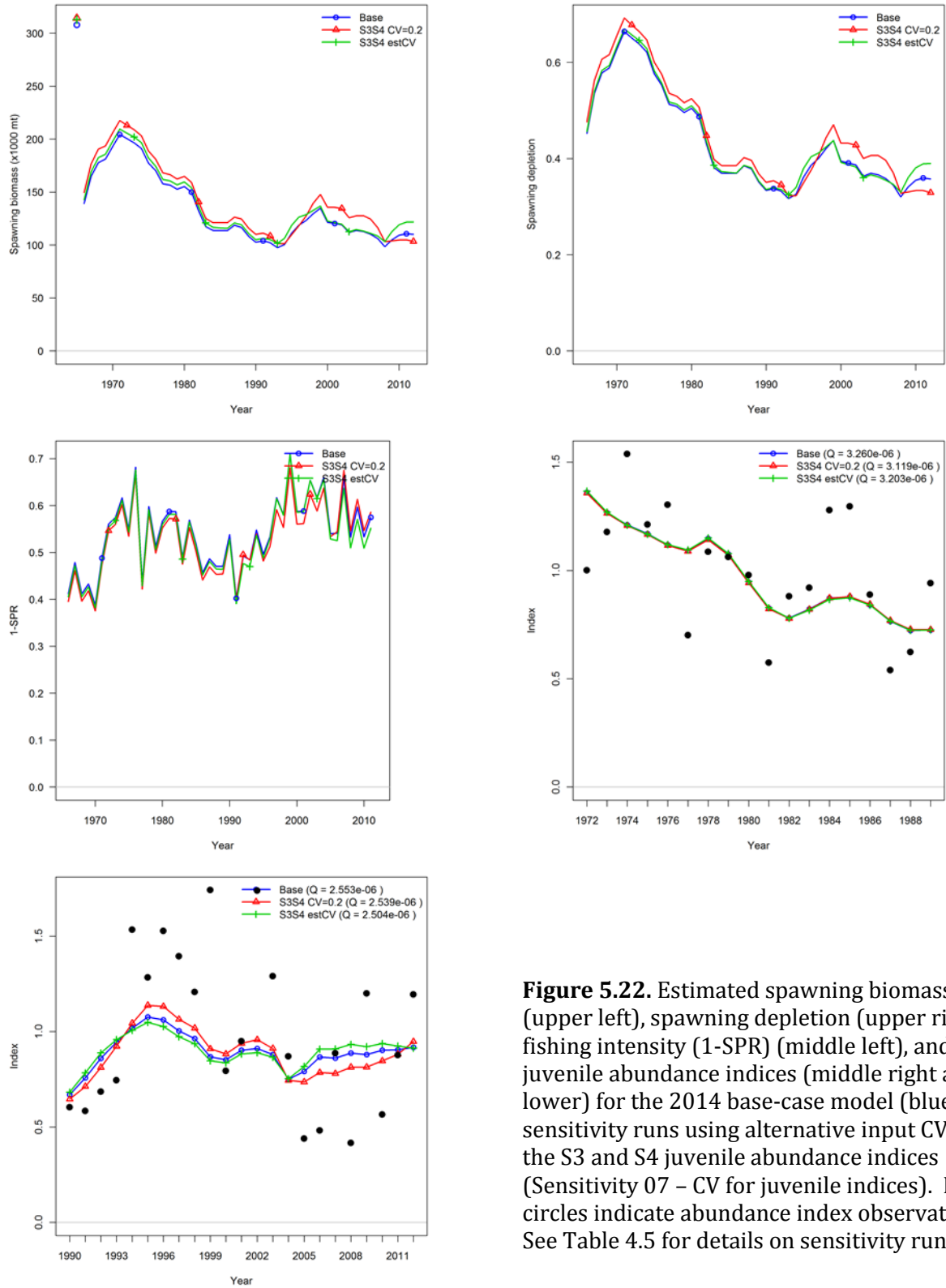

Figure 5.22. Estimated spawning biomass (upper left), spawning depletion (upper right), fishing intensity (1-SPR) (middle left), and fit to juvenile abundance indices (middle right and lower) for the 2014 base-case model (blue) and sensitivity runs using alternative input CVs for the S3 and S4 juvenile abundance indices (Sensitivity 07 – CV for juvenile indices). Black circles indicate abundance index observations. See Table 4.5 for details on sensitivity runs.

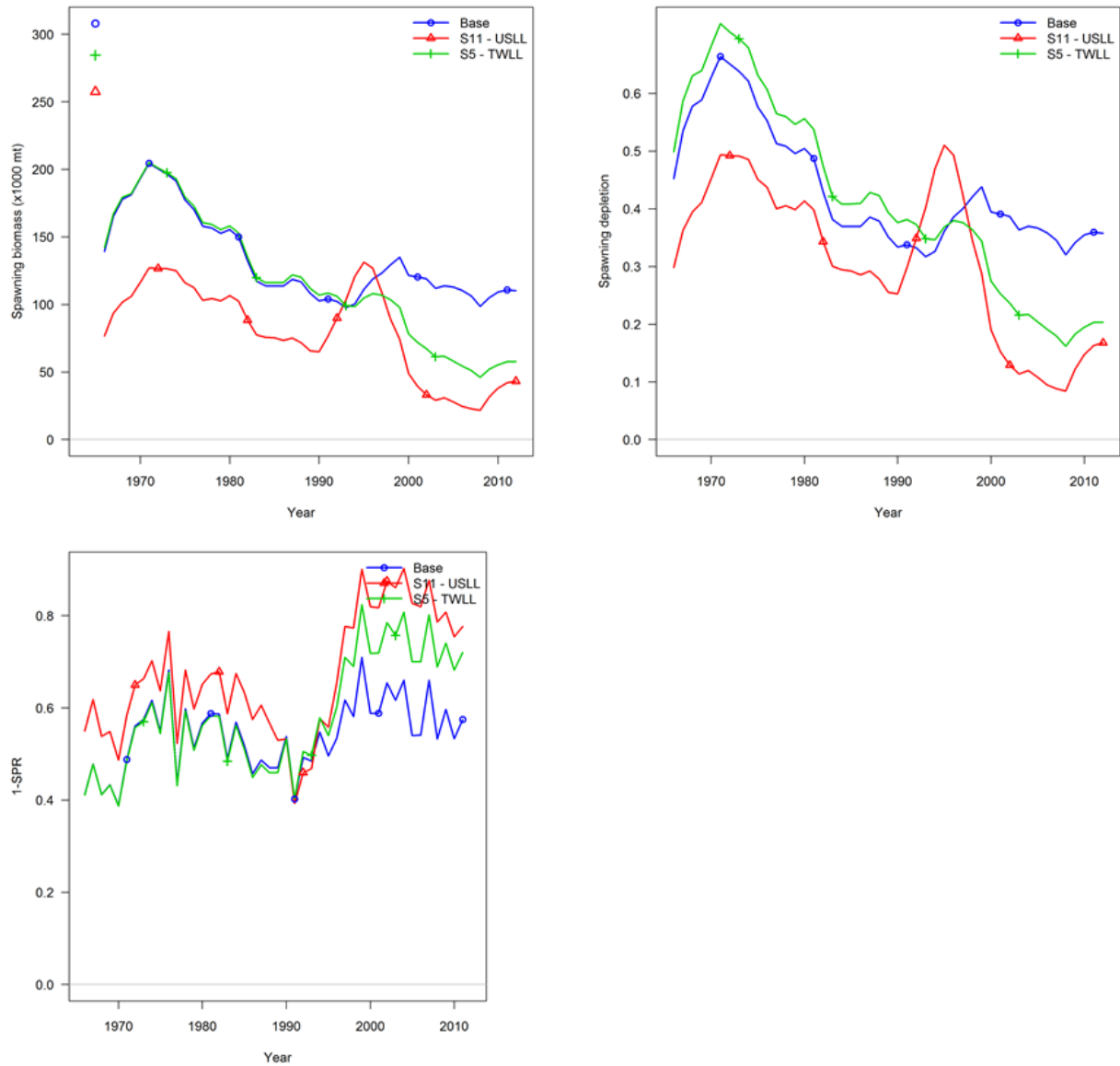

Figure 5.23. Estimated spawning biomass (upper left), spawning depletion (upper right), and fishing intensity (1-SPR) (lower left) for the 2014 base-case model (blue) and sensitivity runs using alternative adult abundance indices: US longline – S11 (red); and Taiwan longline albacore-targeting – S5 (green) (Sensitivity 08 – alternative adult indices). See Table 4.5 for details on sensitivity runs.

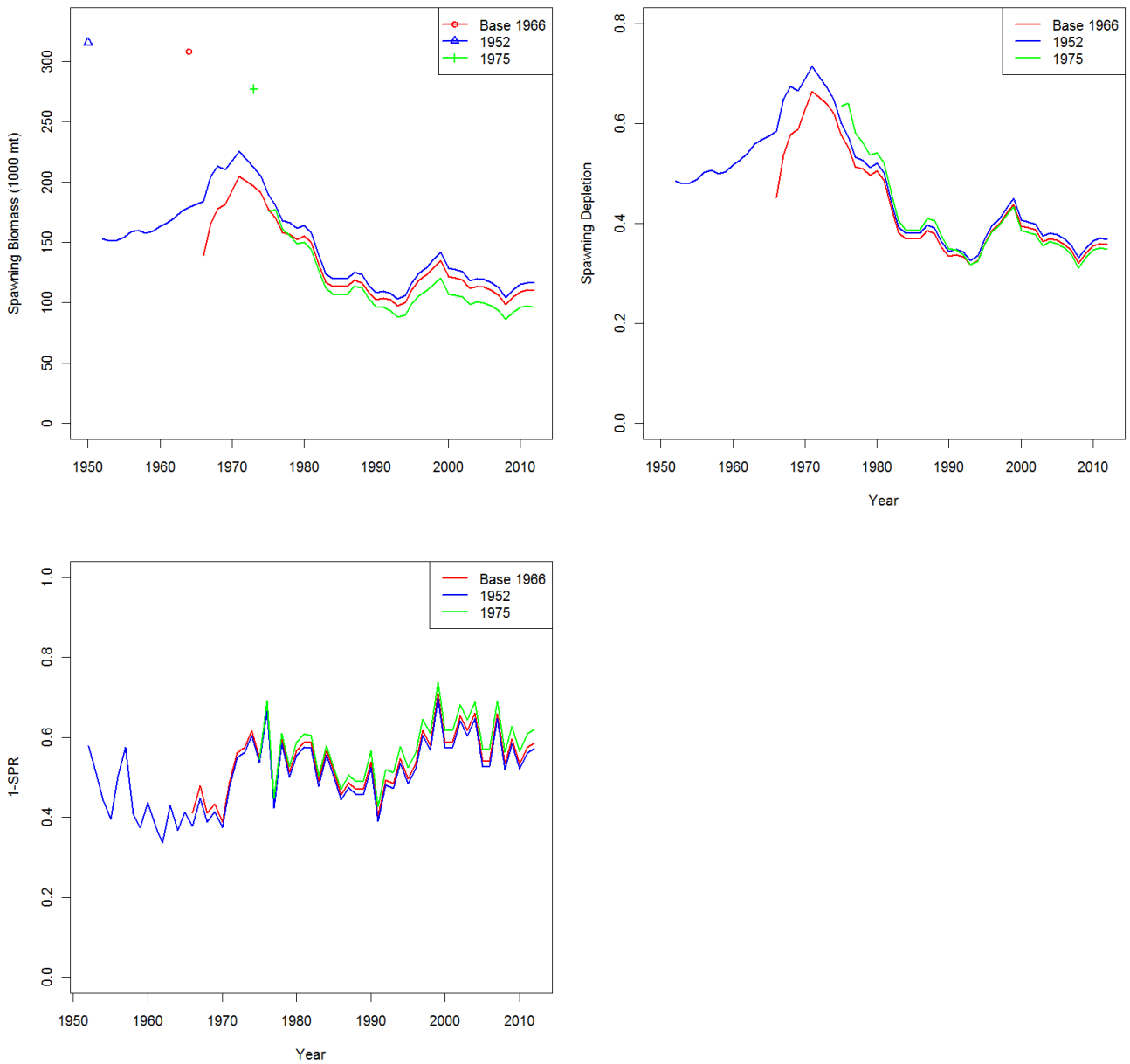

Figure 5.24. Estimated spawning biomass (upper left), spawning depletion (upper right), and fishing intensity (1-SPR) (lower left) for the 2014 base-case model (red) and sensitivity runs using alternative start years for the model (Sensitivity 09 – start year). See Table 4.5 for details on sensitivity runs.



Figure 5.25. Estimated spawning biomass (upper left), spawning depletion (upper right), fishing intensity (1-SPR) (lower left), and recruitment (lower right) for the 2014 base-case model (blue) and sensitivity runs using alternative variance adjustments for size composition data (Sensitivity 10 – size composition weighting). See Table 4.5 for details on sensitivity runs.

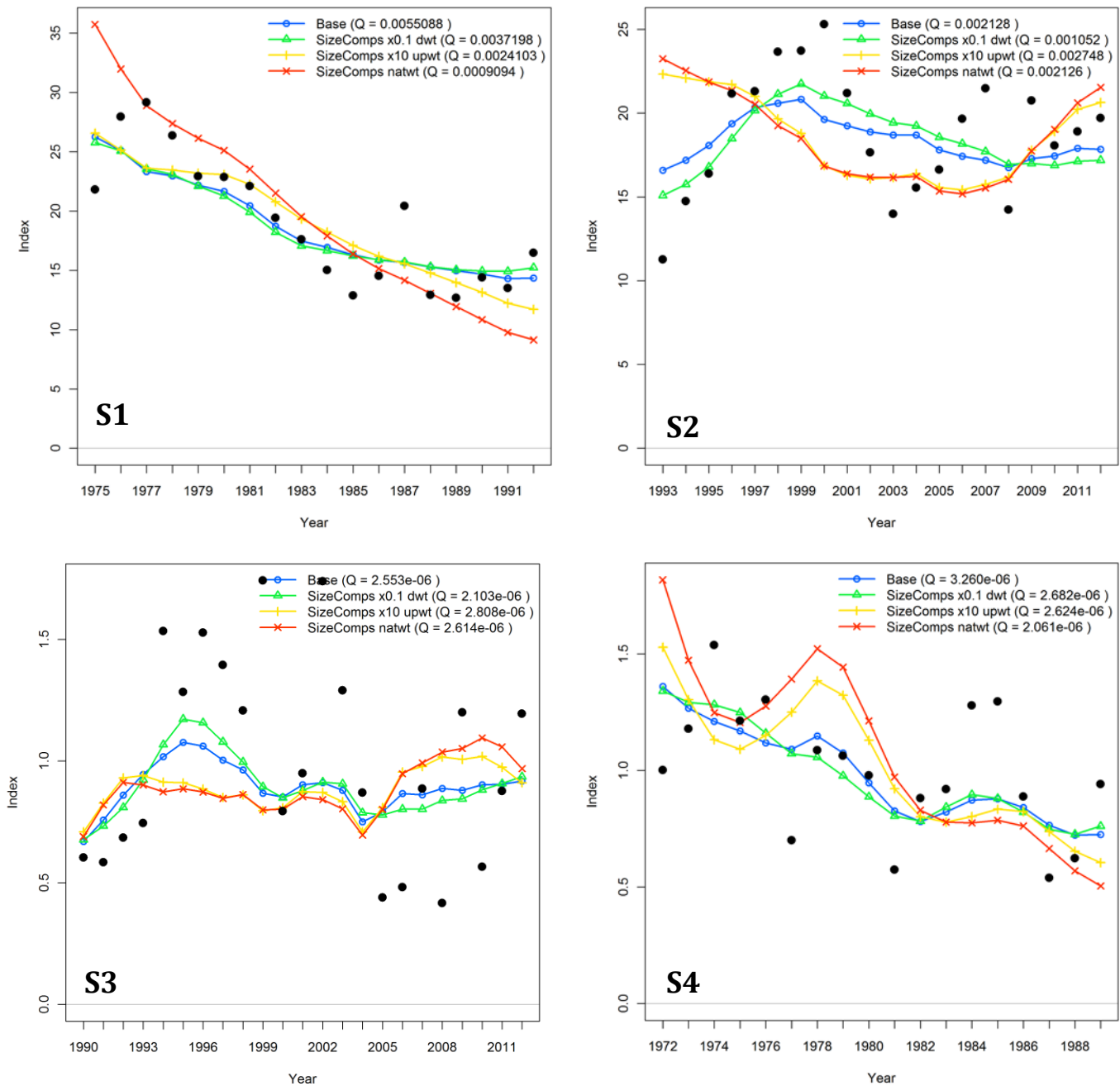

Figure 5.26. Model fits to adult – S1 and S2 (upper) and juvenile – S3 and S4 (lower) indices for the 2014 base-case model (blue) and sensitivity runs using alternative variance adjustments for size composition data (Sensitivity 10 – size composition weighting). Black circles indicate abundance index observations. See Table 4.5 for details on sensitivity runs.

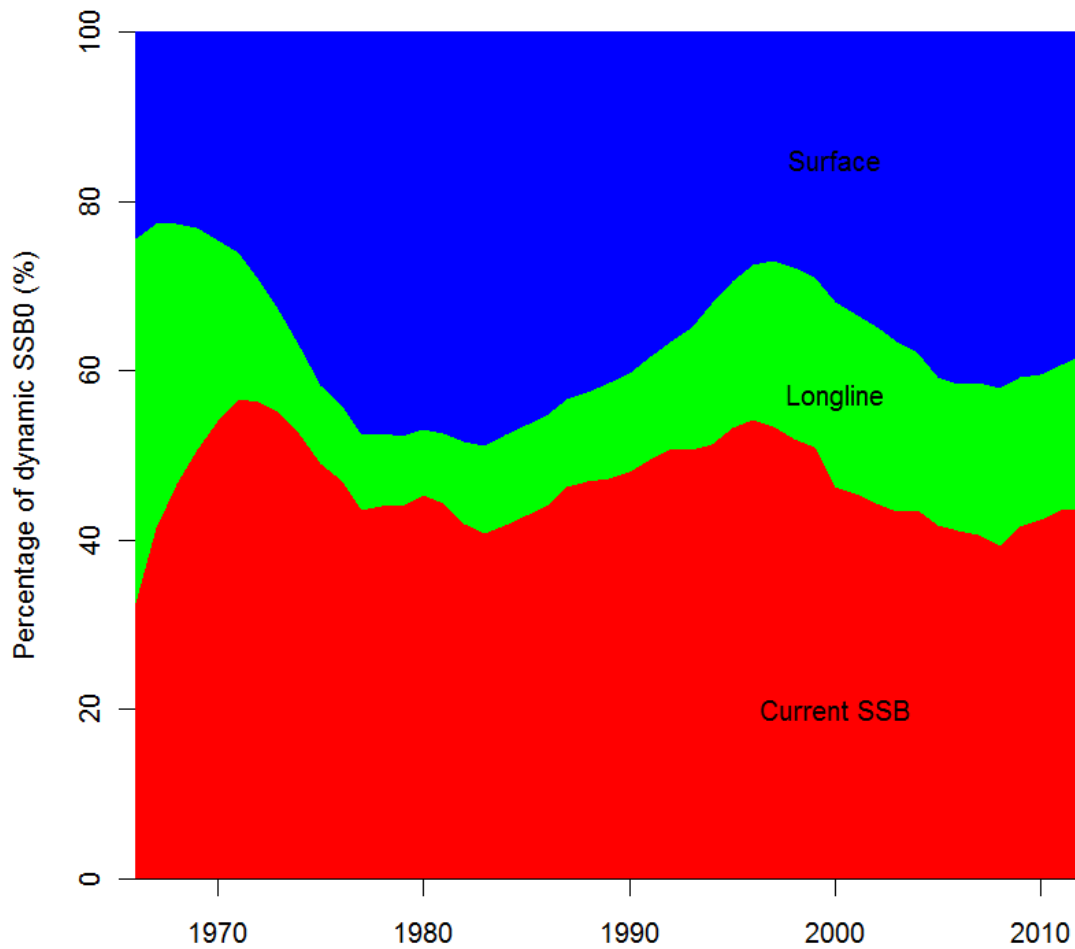

Figure 5.27. Fishery impact analysis showing current female albacore spawning stock biomass (SSB) (red) estimated by the 2014 base case model as a percentage of the dynamic virgin spawning biomass (SSB_0). Shaded areas show the portions of the fishing impact attributed to longline (green) (US, Japan, Taiwan, Korea, China, and others) and surface (blue) (US, Canada, Japan) fisheries (primarily troll and pole-and-line gear, but includes gillnet and all other gears except longline).

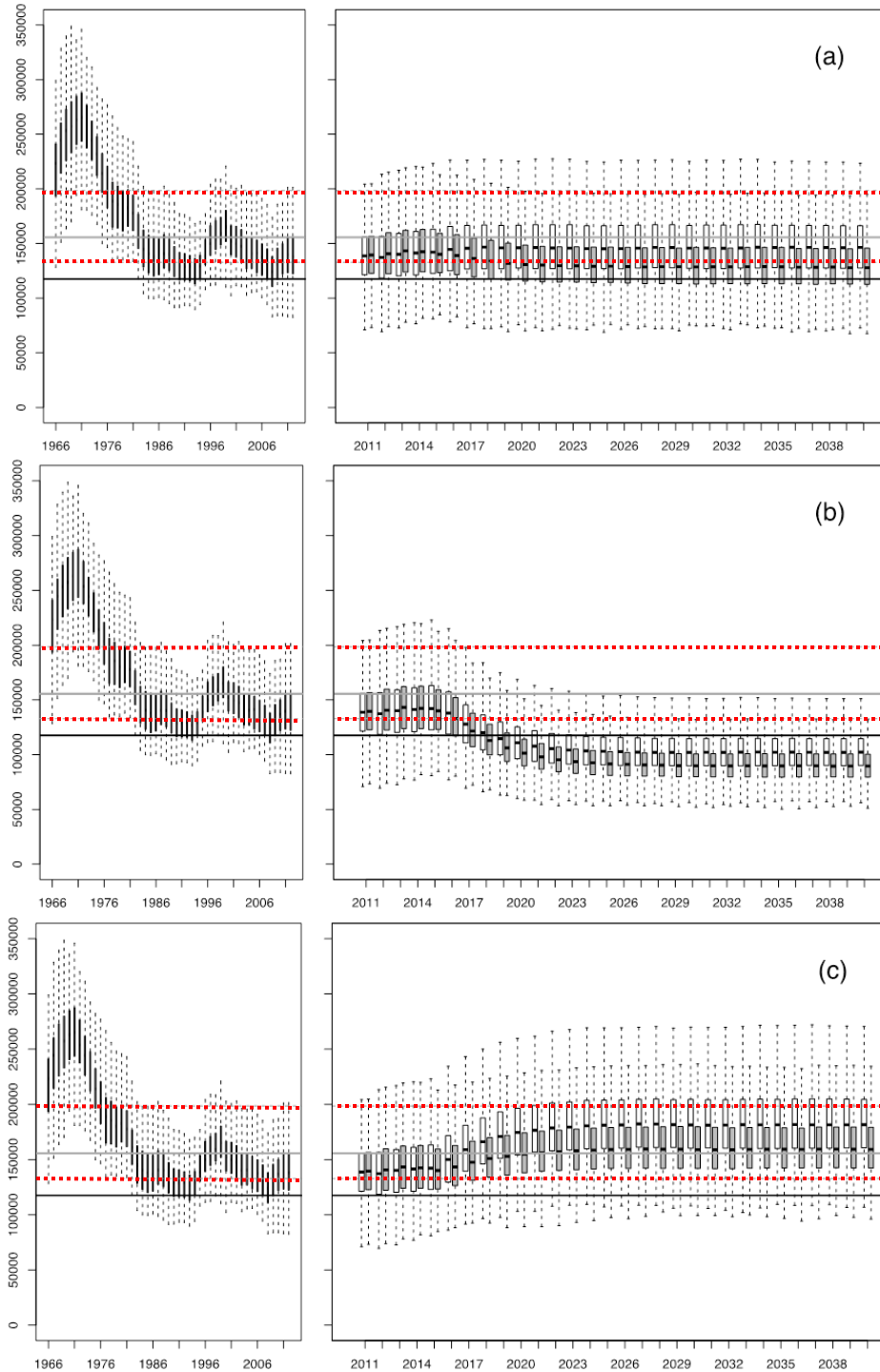

Figure 5.28. Historical (left) and future trajectories of north Pacific albacore (*Thunnus alalunga*) female spawning biomass (SSB) based on two constant harvest scenarios ($F_{2002-2004}$ - gray boxplot; $F_{2010-2012}$ - white boxplot) for average historical recruitment (a), low historical recruitment (b) and high historical recruitment (c) scenarios. The solid gray and red dashed lines represent median, 25% and 75% quartiles of past SSB, respectively. The solid black line is the average of 10 lowest estimated historical female SSB values, i.e., the SSB-ATHL threshold. Outlier values are excluded from these figures.

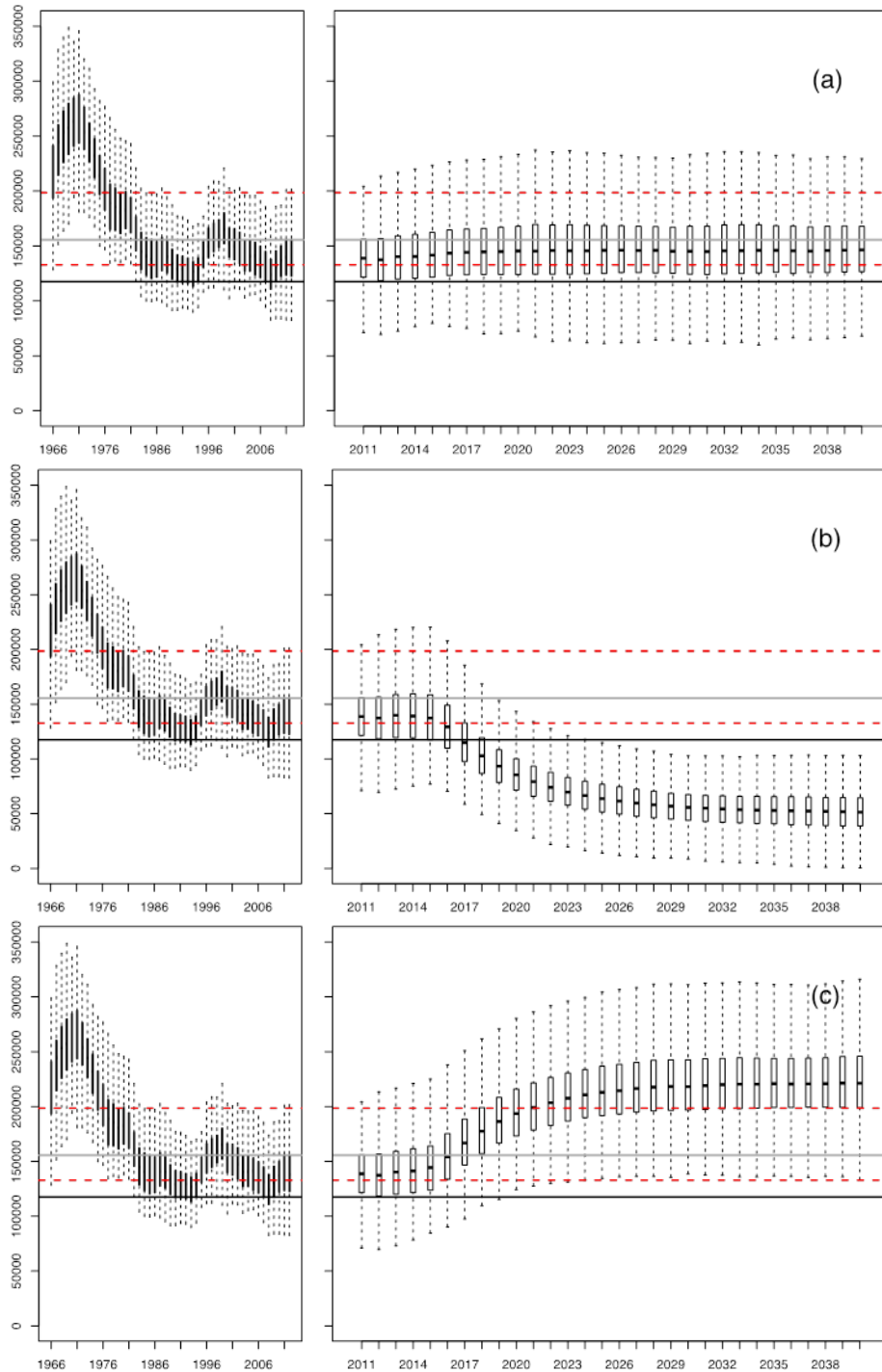

Figure 5.29. Historical (left) and future trajectories of north Pacific albacore (*Thunnus alalunga*) female spawning biomass (SSB) based on a constant catch harvest scenario (average of catches in 2010 to 2012, = 76,445 t) for (a) average historical recruitment, (b) low historical recruitment, and (c) high historical recruitment scenarios. The solid gray and red dashed lines represent median, 25% and 75% quartiles of historical SSB, respectively. The solid black line is the average of 10 lowest estimated historical female SSB values, i.e., the SSB-ATHL threshold. Outlier values are not shown in these figures.

APPENDIX A

Stock Synthesis starter file (starter.ss) used in the base case model of the north Pacific albacore tuna stock assessment in 2014.

```
# V3.24f
NPALB_dat_20140423.txt
NPALB_ctl_20140423.txt
0 # 0=use init values in control file; 1=use ss2.par
1 # run display detail (0,1,2)
1 # detailed age-structured reports in SS2.rep (0,1)
1 # write detailed checkup.sso file (0,1)
3 # write parm values to ParmTrace.sso (0=no,1=good,active; 2=good,all; 3=every_iter,all_parms)
1 # write to cumreport.sso (0=no,1=like&timeseries; 2=add survey fits)
0 # Include prior_like for non-estimated parameters (0,1)
1 # Use Soft Boundaries to aid convergence (0,1) (recommended)
1 # Number of bootstrap datafiles to produce
10 # Turn off estimation for parameters entering after this phase
10 # MCMC burn interval
2 # MCMC thin interval
0 # jitter initial parm value by this fraction
-1 # min yr for Spbio_sdreport
-1 # max yr for Spbio_sdreport
0 # N individual STD years
#vector of year values
0.0001 # final convergence criteria (e.g. 1.0e-04)
0 # retrospective year relative to end year (e.g. -4)
1 # min age for calc of summary biomass
1 # Depletion basis: denom is: 0=skip; 1=rel X*B0; 2=rel X*Bmsy; 3=rel X*B_styr
1 # Fraction (X) for Depletion denominator (e.g. 0.4)
4 # (1-SPR)_reporting: 0=skip; 1=rel(1-SPR); 2=rel(1-SPR_MS); 3=rel(1-SPR_Btarget); 4=notrel
0 # F_std reporting: 0=skip; 1=exploit(Bio); 2=exploit(Num); 3=sum(frates)
0 # F_report_basis: 0=raw; 1=rel Fspr; 2=rel Fmsy ; 3=rel Fbtgt
999 # check value for end of file
```

APPENDIX B

Stock Synthesis control file (NPALB_ctl_20140423.txt) used in the base case model of the north Pacific albacore tuna stock assessment in 2014.

```
#V3.24f
#_data_and_control_files: NPALB_dat_20140423.txt // NPALB_ctl_20140423.txt
#_SS-V3.24f-safe-Win64;_08/03/2012;_Stock_Synthesis_by_Richard_Methot_(NOAA)_using_ADMB_11
#
# FltNum      FleetID  Description          Additional Catch Included
# 1           F1      Japan Pole-and-Line Quarter 1 & 2   Japan, Korea & Taiwan Gillnet and Japan Miscellaneous
# 2           F2      Japan Pole-and-Line Quarter 3 & 4
# 3           F3      Japan Longline Area 1, Quarter 1 & 2, catch in metric tons
# 4           F4      Japan Longline Area 1, Quarter 3 & 4, catch in metric tons
# 5           F5      Japan Longline Area 1, Quarter 1 & 2, catch in 1000s of fish
# 6           F6      Japan Longline Area 1, Quarter 3 & 4, catch in 1000s of fish
# 7           F7      EPO Surface fisheries
# 8           F8      Japan Longline Area 2 & 3, Quarter 1 & 4, catch in metric tons (1966-1974, 1993-2012)   Korea
Longline (1966-1974, 1993-2012)
# 9           F9      Japan Longline Area 2 & 3, Quarter 2 & 3, catch in metric tons (1966-1974, 1993-2012)
# 10          F10     Japan Longline Area 2 & 3, Quarter 1 & 4, catch in 1000s of fish (1966-1974, 1993-2012)
# 11          F11     Japan Longline Area 2 & 3, Quarter 2 & 3, catch in 1000s of fish (1966-1974, 1993-2012)
# 12          F12     Japan Longline Area 2 & 3, Quarter 1 & 4, catch in metric tons (1975-1992) Korea Longline (1975-
1992)
# 13          F13     Japan Longline Area 2 & 3, Quarter 2 & 3, catch in metric tons (1975-1992)
# 14          F14     Japan Longline Area 2 & 3, Quarter 1 & 4, catch in 1000s of fish (1975-1992)
# 15          F15     Japan Longline Area 2 & 3, Quarter 2 & 3, catch in 1000s of fish (1975-1992)
# 16          F16     Japan Longline Area 4, Quarter 1 & 4, catch in metric tons
# 17          F17     Japan Longline Area 4, Quarter 2 & 3, catch in metric tons
# 18          F18     Japan Longline Area 4, Quarter 1 & 4, catch in 1000s of fish
# 19          F19     Japan Longline Area 4, Quarter 2 & 3, catch in 1000s of fish
# 20          F20     US Longline Deep-Set   Japan Longline Area 6 and China and Others Longline
# 21          F21     US Longline Shallow-Set
# 22          F22     Taiwan Longline, albacore targeting
# 23          F23     Taiwan Longline, non-albacore targeting
# 24          F24     Japan Longline Area 5
# XX          S1      Japan Longline Index, Area 2 & 3, (1975-1992) (put into model as index of F12)
# XX          S2      Japan Longline Index, Area 2 & 3, (1993-2012) (put into model as index of F8)
# XX          S3      Japan Pole-and-Line Index, (1972-1989) (put into model as index of F1)
# XX          S4      Japan Pole-and-Line Index, (1990-2012) (put into model as index of F2)
#
# See Table 3.1 and 3.2 in stock assessment report for details
#
1 #_N_Growth_Patterns
1 #_N_Morphs_Within_GrowthPattern
#_Cond 1 #_Morph_between/within_stdev_ratio (no read if N_morphs=1)
#_Cond 1 #vector_Morphdist (-1_in_first_val_gives_normal_approx)
#
1 # number of recruitment assignments (overrides GP*area*seas parameter values)
0 # recruitment interaction requested
#GP seas area for each recruitment assignment
1 2 1
#
#_Cond 0 # N_movement_definitions goes here if N_areas > 1
#_Cond 1.0 # first age that moves (real age at begin of season, not integer) also cond on do_migration>0
#_Cond 1 1 1 2 4 10 # example move definition for seas=1, morph=1, source=1 dest=2, age1=4, age2=10
#
8 #_Nblock_Patterns
1 1 3 1 1 2 1 2 #_blocks_per_pattern
```

```

# begin and end years of blocks
1993 2012
1989 2012
1975 1987 1988 1995 1996 2012
2005 2012
1990 2012
1975 1997 1998 2012
1985 2012
1984 1993 1994 2012
#
0.5 #_fracfemale
0 #_natM_type: 0=1Parm; 1=N_breakpoints; 2=Lorenzen; 3=agespecific; 4=agespec_withseasinterpolate
#_no additional input for selected M option; read 1P per morph
1 # GrowthModel: 1=vonBert with L1&L2; 2=Richards with L1&L2; 3=age_speciific_K; 4=not implemented
1 #_Growth_Age_for_L1
999 #_Growth_Age_for_L2 (999 to use as Linf)
0 #_SD_add_to_LAA (set to 0.1 for SS2 V1.x compatibility)
0 #_CV_Growth_Pattern: 0 CV=f(LAA); 1 CV=F(A); 2 SD=F(LAA); 3 SD=F(A); 4 logSD=F(A)
3 #_maturity_option: 1=length logistic; 2=age logistic; 3=read age-maturity matrix by growth_pattern; 4=read age-
fecundity; 5=read fec and wt from wtatage.ss
#_Age_Maturity by growth pattern
0 0 0 0 0.5 1 1 1 1 1 1 1 1 1 1
5 #_First_Mature_Age
1 #_fecundity option:(1)eggs=Wt*(a+b*Wt);(2)eggs=a*L^b;(3)eggs=a*Wt^b; (4)eggs=a+b*L; (5)eggs=a+b*W
0 #_hermaphroditism option: 0=none; 1=age-specific fxn
2 #_parameter_offset_approach (1=none, 2= M, G, CV_G as offset from female-GP1, 3=like SS2 V1.x)
1 #_env/block/dev_adjust_method (1=standard; 2=logistic transform keeps in base parm bounds; 3=standard w/ no
bound check)
#
#_growth_parms
#_LO HI INIT PRIOR PR_type SD PHASE env-var use_dev dev_minyr dev_maxyr dev_stddev Block Block_Fxn
0.1 0.8 0.3 0.3 -1 99 -1 0 0 0 0 0 0 # NatM_p_1_Fem_GP_1
10 60 43.504 44 -1 99 -6 0 0 0 0 0 0 # L_at_Amin_Fem_GP_1
100 160 106.57 146.46 -1 99 -6 0 0 0 0 0 0 # L_at_Amax_Fem_GP_1
0.01 0.4 0.29763 0.149 -1 99 -6 0 0 0 0 0 0 # VonBert_K_Fem_GP_1
0.01 0.3 0.06 0.1 -1 99 -6 0 0 0 0 0 0 # CV_young_Fem_GP_1
0.01 0.3 0.04 0.08 -1 99 -5 0 0 0 0 0 0 # CV_old_Fem_GP_1
-10 10 0 0.3 -1 99 -1 0 0 0 0 0 0 # NatM_p_1_Mal_GP_1
-10 10 0.089184 40.2 -1 99 -6 0 0 0 0 0 0 # L_at_Amin_Mal_GP_1
-10 10 0.111578 146.46 -1 99 -6 0 0 0 0 0 0 # L_at_Amax_Mal_GP_1
-10 10 -0.3598 0.149 -1 99 -6 0 0 0 0 0 0 # VonBert_K_Mal_GP_1
-10 10 0 0.1 -1 99 -6 0 0 0 0 0 0 # CV_young_Mal_GP_1
-10 10 0 0.08 -1 99 -5 0 0 0 0 0 0 # CV_old_Mal_GP_1
-2 2 8.7e-005 8.7e-005 -1 99 -3 0 0 0 0 0 0 # Wtlen_1_Fem
-2 4 2.67 2.67 -1 99 -3 0 0 0 0 0 0 # Wtlen_2_Fem
1 10 5 5 -1 99 -3 0 0 0 0 0 0 # Mat50%_Fem
-5 5 -3.746 -3.746 -1 99 -3 0 0 0 0 0 0 # Mat_slope_Fem
0 3 1 1 -1 99 -3 0 0 0 0 0 0 # Eggs/kg_inter_Fem
0 3 0 0 -1 99 -3 0 0 0 0 0 0 # Eggs/kg_slope_wt_Fem
-2 2 8.7e-005 8.7e-005 -1 99 -3 0 0 0 0 0 0 # Wtlen_1_Mal
-2 4 2.67 2.67 -1 99 -3 0 0 0 0 0 0 # Wtlen_2_Mal
-4 4 0 1 -1 99 -3 0 0 0 0 0 0 # RecrDist_GP_1
-4 4 0 1 -1 99 -3 0 0 0 0 0 0 # RecrDist_Area_1
-4 4 -4 1 -1 99 -3 0 0 0 0 0 0 # RecrDist_Seas_1
-4 4 0 1 -1 99 -3 0 0 0 0 0 0 # RecrDist_Seas_2
-4 4 -4 1 -1 99 -3 0 0 0 0 0 0 # RecrDist_Seas_3
-4 4 -4 1 -1 99 -3 0 0 0 0 0 0 # RecrDist_Seas_4
-4 4 1 1 -1 99 -3 0 0 0 0 0 0 # CohortGrowDev
#
#_Cond 0 #custom_MG-env_setup (0/1)
#_Cond -2 2 0 0 -1 99 -2 #_placeholder when no MG-envron parameters

```

```

#
#_Cond 0 #custom_MG-block_setup (0/1)
#_Cond -2 2 0 0 -1 99 -2 #_placeholder when no MG-block parameters
#_Cond No MG parm trends
#
#_seasonal_effects_on_biology_parms
27 31 0 0 0 35 39 0 0 #_femwtlen1,femwtlen2,mat1,mat2,fec1,fec2,Malewtlen1,malewtlen2,L1,K
-2 2 0 0 -1 99 -2 # F-WL1_seas_1
-2 2 -0.80235 -0.80235 -1 99 -2 # F-WL1_seas_2
-2 2 -1.42139 -1.42139 -1 99 -2 # F-WL1_seas_3
-2 2 -1.1337 -1.1337 -1 99 -2 # F-WL1_seas_4
-2 2 0 0 -1 99 -2 # F-WL2_seas_1
-2 2 0.061726 0.061726 -1 99 -2 # F-WL2_seas_2
-2 2 0.113195 0.113195 -1 99 -2 # F-WL2_seas_3
-2 2 0.089505 0.089505 -1 99 -2 # F-WL2_seas_4
-2 2 0 0 -1 99 -2 # M-WL1_seas_1
-2 2 -0.80235 -0.80235 -1 99 -2 # M-WL1_seas_2
-2 2 -1.42139 -1.42139 -1 99 -2 # M-WL1_seas_3
-2 2 -1.1337 -1.1337 -1 99 -2 # M-WL1_seas_4
-2 2 0 0 -1 99 -2 # M-WL2_seas_1
-2 2 0.061726 0.061726 -1 99 -2 # M-WL2_seas_2
-2 2 0.113195 0.113195 -1 99 -2 # M-WL2_seas_3
-2 2 0.089505 0.089505 -1 99 -2 # M-WL2_seas_4
#
#_Cond -4 #_MGparm_Dev_Phase
#
#_Spawner-Recruitment
3 #_SR_function: 2=Ricker; 3=std_B-H; 4=SCAA; 5=Hockey; 6=B-H_flattop; 7=survival_3Parm
#_LO HI INIT PRIOR PR_type SD PHASE
5 15 10.7727 11.4 -1 99 1 # SR_LN(R0)
0.2 1 0.9 0.9 -1 99 -4 # SR_BH_steep
0 2 0.5 0.5 -1 99 -1 # SR_sigmaR
-5 5 0 0 -1 99 -1 # SR_envlink
-5 5 0.0515384 0 -1 99 1 # SR_R1_offset
0 0 0 0 -1 99 -1 # SR_autocorr
0 #_SR_env_link
0 #_SR_env_target_0=none;1=devs;_2=R0;_3=steepness
2 #do_recdev: 0=none; 1=devvector; 2=simple deviations
1966 # first year of main recr_devs; early devs can precede this era
2012 # last year of main recr_devs; forecast devs start in following year
1 #_recdev phase
1 # (0/1) to read 13 advanced options
1956 #_recdev_early_start (0=none; neg value makes relative to recdev_start)
3 #_recdev_early_phase
0 #_forecast_recruitment phase (incl. late recr) (0 value resets to maxphase+1)
1 #_lambda for Fcast_recr_like occurring before endyr+1
1957 #_last_early_yr_nobias_adj_in_MPD
1974 #_first_yr_fullbias_adj_in_MPD
2009 #_last_yr_fullbias_adj_in_MPD
2011 #_first_recent_yr_nobias_adj_in_MPD
0.75 #_max_bias_adj_in_MPD (-1 to override ramp and set biasadj=1.0 for all estimated recdevs)
0 #_period of cycles in recruitment (N parms read below)
-5 #min rec_dev
5 #max rec_dev
0 #_read_recdevs
#_end of advanced SR options
#
#_placeholder for full parameter lines for recruitment cycles
# read specified recr devs
#_Yr Input_value
#

```

```

# all recruitment deviations
#DisplayOnly 0.0299441 # Early_InitAge_10
#DisplayOnly 0.0372355 # Early_InitAge_9
#DisplayOnly 0.0127798 # Early_InitAge_8
#DisplayOnly -0.0529008 # Early_InitAge_7
#DisplayOnly -0.112007 # Early_InitAge_6
#DisplayOnly 0.00955519 # Early_InitAge_5
#DisplayOnly 0.299368 # Early_InitAge_4
#DisplayOnly -0.100482 # Early_InitAge_3
#DisplayOnly -0.0745617 # Early_InitAge_2
#DisplayOnly 0.371593 # Early_InitAge_1
#DisplayOnly 0.140432 # Main_RecrDev_1966
#DisplayOnly 0.211908 # Main_RecrDev_1967
#DisplayOnly 0.307952 # Main_RecrDev_1968
#DisplayOnly 0.374396 # Main_RecrDev_1969
#DisplayOnly 0.0644953 # Main_RecrDev_1970
#DisplayOnly 0.394295 # Main_RecrDev_1971
#DisplayOnly 0.162291 # Main_RecrDev_1972
#DisplayOnly 0.207266 # Main_RecrDev_1973
#DisplayOnly 0.0990777 # Main_RecrDev_1974
#DisplayOnly 0.297137 # Main_RecrDev_1975
#DisplayOnly 0.0665647 # Main_RecrDev_1976
#DisplayOnly -0.392084 # Main_RecrDev_1977
#DisplayOnly -0.256452 # Main_RecrDev_1978
#DisplayOnly -0.116355 # Main_RecrDev_1979
#DisplayOnly -0.0503454 # Main_RecrDev_1980
#DisplayOnly -0.140353 # Main_RecrDev_1981
#DisplayOnly 0.0549684 # Main_RecrDev_1982
#DisplayOnly -0.370121 # Main_RecrDev_1983
#DisplayOnly -0.592554 # Main_RecrDev_1984
#DisplayOnly -0.339475 # Main_RecrDev_1985
#DisplayOnly -0.177941 # Main_RecrDev_1986
#DisplayOnly -0.647031 # Main_RecrDev_1987
#DisplayOnly -0.315346 # Main_RecrDev_1988
#DisplayOnly -0.138196 # Main_RecrDev_1989
#DisplayOnly 0.135888 # Main_RecrDev_1990
#DisplayOnly -0.122611 # Main_RecrDev_1991
#DisplayOnly 0.193005 # Main_RecrDev_1992
#DisplayOnly 0.254648 # Main_RecrDev_1993
#DisplayOnly 0.215513 # Main_RecrDev_1994
#DisplayOnly -0.230777 # Main_RecrDev_1995
#DisplayOnly 0.303752 # Main_RecrDev_1996
#DisplayOnly -0.131834 # Main_RecrDev_1997
#DisplayOnly -0.182655 # Main_RecrDev_1998
#DisplayOnly 0.250853 # Main_RecrDev_1999
#DisplayOnly 0.122495 # Main_RecrDev_2000
#DisplayOnly -0.00709523 # Main_RecrDev_2001
#DisplayOnly -0.12659 # Main_RecrDev_2002
#DisplayOnly -0.251461 # Main_RecrDev_2003
#DisplayOnly 0.240963 # Main_RecrDev_2004
#DisplayOnly -0.0247452 # Main_RecrDev_2005
#DisplayOnly -0.0484855 # Main_RecrDev_2006
#DisplayOnly 0.0158466 # Main_RecrDev_2007
#DisplayOnly 0.0837097 # Main_RecrDev_2008
#DisplayOnly -0.0708821 # Main_RecrDev_2009
#DisplayOnly -0.00837128 # Main_RecrDev_2010
#DisplayOnly 0.0604381 # Main_RecrDev_2011
#DisplayOnly 0 # Main_RecrDev_2012
#
#Fishing Mortality info
0.1 # F ballpark for tuning early phases

```

```

-2010 # F ballpark year (neg value to disable)
3 # F_Method: 1=Pope; 2=instan. F; 3=hybrid (hybrid is recommended)
4 # max F or harvest rate, depends on F_Method
# no additional F input needed for Fmethod 1
# if Fmethod=2; read overall start F value; overall phase; N detailed inputs to read
# if Fmethod=3; read N iterations for tuning for Fmethod 3
5 # N iterations for tuning F in hybrid method (recommend 3 to 7)
#
#_initial_F_parms
#_LO HI INIT PRIOR PR_type SD PHASE
0 4 0.346259 0.5 -1 99 1 # InitF_1F1
0 1 0 0 -1 99 -2 # InitF_2F2
0 1 0 0 -1 99 -2 # InitF_3F3
0 1 0 0 -1 99 -2 # InitF_4F4
0 1 0 0 -1 99 -2 # InitF_5F5
0 1 0 0 -1 99 -2 # InitF_6F6
0 1 0 0 -1 99 -1 # InitF_7F7
0 4 1.36986 0.5 -1 99 1 # InitF_8F8
0 1 0 0 -1 99 -2 # InitF_9F9
0 1 0 0 -1 99 -2 # InitF_10F10
0 1 0 0 -1 99 -2 # InitF_11F11
0 1 0 0 -1 99 -1 # InitF_12F12
0 1 0 0 -1 99 -2 # InitF_13F13
0 1 0 0 -1 99 -2 # InitF_14F14
0 1 0 0 -1 99 -2 # InitF_15F15
0 1 0 0 -1 99 -1 # InitF_16F16
0 1 0 0 -1 99 -2 # InitF_17F17
0 1 0 0 -1 99 -2 # InitF_18F18
0 1 0 0 -1 99 -2 # InitF_19F19
0 1 0 0 -1 99 -2 # InitF_20F20
0 1 0 0 -1 99 -2 # InitF_21F21
0 1 0 0 -1 99 -2 # InitF_22F22
0 1 0 0 -1 99 -2 # InitF_23F23
0 1 0 0 -1 99 -2 # InitF_24F24
#
#_Q_setup
#_Q_type options: <0=mirror, 0=float_nobiasadj, 1=float_biasadj, 2=parm_nobiasadj, 3=parm_w_random_dev,
4=parm_w_randwalk, 5=mean_unbiased_float_assign_to_parm
#_for_env-var:_enter_index_of_the_env-var_to_be_linked
#_Den-dep env-var extra_se Q_type
0 0 0 0 # 1 F1
0 0 0 0 # 2 F2
0 0 0 0 # 3 F3
0 0 0 0 # 4 F4
0 0 0 0 # 5 F5
0 0 0 0 # 6 F6
0 0 0 0 # 7 F7
0 0 0 0 # 8 F8
0 0 0 0 # 9 F9
0 0 0 0 # 10 F10
0 0 0 0 # 11 F11
0 0 0 0 # 12 F12
0 0 0 0 # 13 F13
0 0 0 0 # 14 F14
0 0 0 0 # 15 F15
0 0 0 0 # 16 F16
0 0 0 0 # 17 F17
0 0 0 0 # 18 F18
0 0 0 0 # 19 F19
0 0 0 0 # 20 F20
0 0 0 0 # 21 F21

```

```

0 0 0 0 # 22 F22
0 0 0 0 # 23 F23
0 0 0 0 # 24 F24
#
#_Cond 0 #_If q has random component, then 0=read one parm for each fleet with random q; 1=read a parm for each year
of index
#_Q_parms(if_any)
#
#_size_selex_types
#discard_options:_0=none;_1=define_retention;_2=retention&mortality;_3=all_discarded_dead
#_Pattern Discard Male Special
24 0 0 0 # 1 F1
24 0 0 0 # 2 F2
24 0 0 0 # 3 F3
24 0 0 0 # 4 F4
5 0 0 3 # 5 F5
5 0 0 4 # 6 F6
24 0 0 0 # 7 F7
24 0 0 0 # 8 F8
5 0 0 8 # 9 F9
5 0 0 8 # 10 F10
5 0 0 8 # 11 F11
1 0 0 0 # 12 F12
5 0 0 12 # 13 F13
5 0 0 12 # 14 F14
5 0 0 12 # 15 F15
1 0 0 0 # 16 F16
1 0 0 0 # 17 F17
5 0 0 16 # 18 F18
5 0 0 17 # 19 F19
1 0 0 0 # 20 F20
24 0 0 0 # 21 F21
24 0 0 0 # 22 F22
5 0 0 20 # 23 F23
24 0 0 0 # 24 F24
#
#_age_selex_types
#_Pattern ___ Male Special
10 0 0 0 # 1 F1
10 0 0 0 # 2 F2
10 0 0 0 # 3 F3
10 0 0 0 # 4 F4
10 0 0 0 # 5 F5
10 0 0 0 # 6 F6
10 0 0 0 # 7 F7
10 0 0 0 # 8 F8
10 0 0 0 # 9 F9
10 0 0 0 # 10 F10
10 0 0 0 # 11 F11
10 0 0 0 # 12 F12
10 0 0 0 # 13 F13
10 0 0 0 # 14 F14
10 0 0 0 # 15 F15
10 0 0 0 # 16 F16
10 0 0 0 # 17 F17
10 0 0 0 # 18 F18
10 0 0 0 # 19 F19
10 0 0 0 # 20 F20
10 0 0 0 # 21 F21
10 0 0 0 # 22 F22
10 0 0 0 # 23 F23

```



```

10 0 0 # 24 F24
#_LO HI INIT PRIOR PR_type SD PHASE env-var use_dev dev_minyr dev_maxyr dev_stddev Block Block_Fxn
27.5 130 86.1243 90 -1 99 2 0 0 0 0 5 2 # SizeSel_1P_1_F1
-9 4 -8 -3 -1 99 -4 0 0 0 0 5 2 # SizeSel_1P_2_F1
-1 9 5.94996 4.6 -1 99 3 0 0 0 0 5 2 # SizeSel_1P_3_F1
-1 9 3.90861 3 -1 99 4 0 0 0 0 5 2 # SizeSel_1P_4_F1
-999 -999 -999 -5 -1 99 -2 0 0 0 0 0 0 # SizeSel_1P_5_F1
-999 -999 -999 -5 -1 99 -2 0 0 0 0 0 0 # SizeSel_1P_6_F1
27.5 130 84.9934 90 -1 99 2 0 0 0 0 5 2 # SizeSel_2P_1_F2
-9 4 -8.10708 -3 -1 99 4 0 0 0 0 5 2 # SizeSel_2P_2_F2
-1 9 7.05164 4.6 -1 99 3 0 0 0 0 5 2 # SizeSel_2P_3_F2
-1 9 2.62329 3 -1 99 4 0 0 0 0 5 2 # SizeSel_2P_4_F2
-999 -999 -999 -5 -1 99 -2 0 0 0 0 0 0 # SizeSel_2P_5_F2
-999 -999 -999 -5 -1 99 -2 0 0 0 0 0 0 # SizeSel_2P_6_F2
27.5 130 74.1754 90 -1 99 2 0 0 0 0 8 2 # SizeSel_3P_1_F3
-9 4 -7.8156 -3 -1 99 4 0 0 0 0 8 2 # SizeSel_3P_2_F3
-1 9 3.6621 4.6 -1 99 3 0 0 0 0 8 2 # SizeSel_3P_3_F3
-1 9 7.11589 3 -1 99 4 0 0 0 0 8 2 # SizeSel_3P_4_F3
-999 -999 -999 -5 -1 99 -2 0 0 0 0 0 0 # SizeSel_3P_5_F3
-999 -999 -999 -5 -1 99 -2 0 0 0 0 0 0 # SizeSel_3P_6_F3
27.5 130 104.92 90 -1 99 2 0 0 0 0 2 2 # SizeSel_4P_1_F4
-9 4 -1.05158 -3 -1 99 4 0 0 0 0 2 2 # SizeSel_4P_2_F4
-1 9 4.97927 4.6 -1 99 3 0 0 0 0 2 2 # SizeSel_4P_3_F4
-1 9 2.45495 3 -1 99 4 0 0 0 0 2 2 # SizeSel_4P_4_F4
-999 -999 -999 -5 -1 99 -2 0 0 0 0 0 0 # SizeSel_4P_5_F4
-999 -999 -999 -5 -1 99 -2 0 0 0 0 0 0 # SizeSel_4P_6_F4
1 80 1 1 -1 99 -4 0 0 0 0 0 0 # SizeSel_5P_1_F5
-80 -80 -80 -80 -1 99 -4 0 0 0 0 0 0 # SizeSel_5P_2_F5
1 80 1 1 -1 99 -4 0 0 0 0 0 0 # SizeSel_6P_1_F6
-80 -80 -80 -80 -1 99 -4 0 0 0 0 0 0 # SizeSel_6P_2_F6
27.5 100 63.5762 66 -1 99 2 0 0 0 0 3 2 # SizeSel_7P_1_F7
-9 4 -8 -3 -1 99 -4 0 0 0 0 3 2 # SizeSel_7P_2_F7
-1 9 3.21434 4 -1 99 3 0 0 0 0 3 2 # SizeSel_7P_3_F7
-1 9 5.34682 5 -1 99 4 0 0 0 0 3 2 # SizeSel_7P_4_F7
-999 -999 -999 -5 -1 99 -2 0 0 0 0 0 0 # SizeSel_7P_5_F7
-999 -999 -999 -5 -1 99 -2 0 0 0 0 0 0 # SizeSel_7P_6_F7
27.5 140 118.493 89 -1 99 2 0 0 0 0 1 2 # SizeSel_8P_1_F8
-9 4 -5.84208 -3 -1 99 4 0 0 0 0 1 2 # SizeSel_8P_2_F8
-4 9 6.62366 6 -1 99 3 0 0 0 0 1 2 # SizeSel_8P_3_F8
-4 9 -2.81847 3 -1 99 2 0 0 0 0 1 2 # SizeSel_8P_4_F8
-999 -999 -999 -5 -1 99 -2 0 0 0 0 0 0 # SizeSel_8P_5_F8
-999 -999 -999 -5 -1 99 -2 0 0 0 0 0 0 # SizeSel_8P_6_F8
1 80 1 1 -1 99 -4 0 0 0 0 0 0 # SizeSel_9P_1_F9
-80 -80 -80 -80 -1 99 -4 0 0 0 0 0 0 # SizeSel_9P_2_F9
1 80 1 1 -1 99 -4 0 0 0 0 0 0 # SizeSel_10P_1_F10
-80 -80 -80 -80 -1 99 -4 0 0 0 0 0 0 # SizeSel_10P_2_F10
1 80 1 1 -1 99 -4 0 0 0 0 0 0 # SizeSel_11P_1_F11
-80 -80 -80 -80 -1 99 -4 0 0 0 0 0 0 # SizeSel_11P_2_F11
27.5 140 112.576 89 -1 99 2 0 0 0 0 0 0 # SizeSel_12P_1_F12
0.01 50 24.9267 6 -1 99 3 0 0 0 0 0 0 # SizeSel_12P_2_F12
1 80 1 1 -1 99 -4 0 0 0 0 0 0 # SizeSel_13P_1_F13
-80 -80 -80 -80 -1 99 -4 0 0 0 0 0 0 # SizeSel_13P_2_F13
1 80 1 1 -1 99 -4 0 0 0 0 0 0 # SizeSel_14P_1_F14
-80 -80 -80 -80 -1 99 -4 0 0 0 0 0 0 # SizeSel_14P_2_F14
1 80 1 1 -1 99 -4 0 0 0 0 0 0 # SizeSel_15P_1_F15
-80 -80 -80 -80 -1 99 -4 0 0 0 0 0 0 # SizeSel_15P_2_F15
27.5 130 119.399 89 -1 99 2 0 0 0 0 7 2 # SizeSel_16P_1_F16
0.01 50 11.5724 6 -1 99 3 0 0 0 0 7 2 # SizeSel_16P_2_F16
27.5 130 119.984 89 -1 99 2 0 0 0 0 7 2 # SizeSel_17P_1_F17
0.01 50 11.468 6 -1 99 3 0 0 0 0 7 2 # SizeSel_17P_2_F17
1 80 1 1 -1 99 -4 0 0 0 0 0 0 # SizeSel_18P_1_F18

```

```

-80 -80 -80 -80 -1 99 -4 0 0 0 0 0 0 # SizeSel_18P_2_F18
1 80 1 1 -1 99 -4 0 0 0 0 0 0 # SizeSel_19P_1_F19
-80 -80 -80 -80 -1 99 -4 0 0 0 0 0 0 # SizeSel_19P_2_F19
27.5 130 109.827 89 -1 99 2 0 0 0 0 0 0 # SizeSel_20P_1_F20
0.01 50 15.3179 6 -1 99 3 0 0 0 0 0 0 # SizeSel_20P_2_F20
27.5 130 99.9199 89 -1 99 2 0 0 0 0 0 4 2 # SizeSel_21P_1_F21
-9 4 1 -3 -1 99 -4 0 0 0 0 0 4 2 # SizeSel_21P_2_F21
-4 9 6.1808 6 -1 99 3 0 0 0 0 0 4 2 # SizeSel_21P_3_F21
-4 9 2.67754 3 -1 99 2 0 0 0 0 0 4 2 # SizeSel_21P_4_F21
-999 -999 -999 -5 -1 99 -2 0 0 0 0 0 0 # SizeSel_21P_5_F21
-999 -999 -999 -5 -1 99 -2 0 0 0 0 0 0 # SizeSel_21P_6_F21
27.5 130 87.8082 89 -1 99 2 0 0 0 0 0 0 # SizeSel_22P_1_F22
-9 4 1 -3 -1 99 -4 0 0 0 0 0 0 # SizeSel_22P_2_F22
-4 9 5.25474 6 -1 99 3 0 0 0 0 0 0 # SizeSel_22P_3_F22
-4 9 5.06285 3 -1 99 2 0 0 0 0 0 0 # SizeSel_22P_4_F22
-999 -999 -999 -5 -1 99 -2 0 0 0 0 0 0 # SizeSel_22P_5_F22
-999 -999 -999 -5 -1 99 -2 0 0 0 0 0 0 # SizeSel_22P_6_F22
1 80 1 1 -1 99 -4 0 0 0 0 0 0 # SizeSel_23P_1_F23
-80 -80 -80 -80 -1 99 -4 0 0 0 0 0 0 # SizeSel_23P_2_F23
27.5 130 111.5 89 -1 99 2 0 0 0 0 0 0 # SizeSel_24P_1_F24
-9 4 -2.11805 -3 -1 99 4 0 0 0 0 0 0 # SizeSel_24P_2_F24
-4 9 6.15264 6 -1 99 3 0 0 0 0 0 0 # SizeSel_24P_3_F24
-4 9 2.4062 3 -1 99 2 0 0 0 0 0 0 # SizeSel_24P_4_F24
-999 -999 -999 -5 -1 99 -2 0 0 0 0 0 0 # SizeSel_24P_5_F24
-999 -999 -999 -5 -1 99 -2 0 0 0 0 0 0 # SizeSel_24P_6_F24
#_Cond 0 #_custom_sel-env_setup (0/1)
#_Cond -2 2 0 0 -1 99 -2 #_placeholder when no enviro fxns
1 #_custom_sel-blk_setup (0/1)
27.5 130 81.9106 90 -1 99 5 # SizeSel_1P_1_F1_BLK5repl_1990
-9 4 -8 -3 -1 99 -5 # SizeSel_1P_2_F1_BLK5repl_1990
-1 9 5.78324 4.6 -1 99 5 # SizeSel_1P_3_F1_BLK5repl_1990
-1 9 4.22922 3 -1 99 5 # SizeSel_1P_4_F1_BLK5repl_1990
27.5 130 54.9759 90 -1 99 5 # SizeSel_2P_1_F2_BLK5repl_1990
-9 4 -0.949802 -3 -1 99 5 # SizeSel_2P_2_F2_BLK5repl_1990
-1 9 3.30984 4.6 -1 99 5 # SizeSel_2P_3_F2_BLK5repl_1990
-1 9 4.13608 3 -1 99 5 # SizeSel_2P_4_F2_BLK5repl_1990
27.5 130 78.0924 90 -1 99 5 # SizeSel_3P_1_F3_BLK8repl_1984
27.5 130 75.1795 90 -1 99 5 # SizeSel_3P_1_F3_BLK8repl_1994
-9 4 1.19811 -3 -1 99 5 # SizeSel_3P_2_F3_BLK8repl_1984
-9 4 -8.68185 -3 -1 99 5 # SizeSel_3P_2_F3_BLK8repl_1994
-1 9 4.36492 4.6 -1 99 5 # SizeSel_3P_3_F3_BLK8repl_1984
-1 9 3.44261 4.6 -1 99 5 # SizeSel_3P_3_F3_BLK8repl_1994
-1 9 4.41259 3 -1 99 5 # SizeSel_3P_4_F3_BLK8repl_1984
-1 9 5.89351 3 -1 99 5 # SizeSel_3P_4_F3_BLK8repl_1994
27.5 130 98.5464 90 -1 99 5 # SizeSel_4P_1_F4_BLK2repl_1989
-9 4 -2.57647 -3 -1 99 5 # SizeSel_4P_2_F4_BLK2repl_1989
-1 9 4.85284 4.6 -1 99 5 # SizeSel_4P_3_F4_BLK2repl_1989
-1 9 4.02335 3 -1 99 5 # SizeSel_4P_4_F4_BLK2repl_1989
27.5 100 64.2277 66 -1 99 5 # SizeSel_7P_1_F7_BLK3repl_1975
27.5 100 60.9772 66 -1 99 5 # SizeSel_7P_1_F7_BLK3repl_1988
27.5 100 65.6936 66 -1 99 5 # SizeSel_7P_1_F7_BLK3repl_1996
-9 4 -8 -3 -1 99 -5 # SizeSel_7P_2_F7_BLK3repl_1975
-9 4 -8 -3 -1 99 -5 # SizeSel_7P_2_F7_BLK3repl_1988
-9 4 -2.87752 -3 -1 99 5 # SizeSel_7P_2_F7_BLK3repl_1996
-1 9 4.20164 4 -1 99 5 # SizeSel_7P_3_F7_BLK3repl_1975
-1 9 3.16822 4 -1 99 5 # SizeSel_7P_3_F7_BLK3repl_1988
-1 9 3.49165 4 -1 99 5 # SizeSel_7P_3_F7_BLK3repl_1996
-1 9 5.73156 5 -1 99 5 # SizeSel_7P_4_F7_BLK3repl_1975
-1 9 5.6121 5 -1 99 5 # SizeSel_7P_4_F7_BLK3repl_1988
-1 9 4.85778 5 -1 99 5 # SizeSel_7P_4_F7_BLK3repl_1996
27.5 140 116.986 89 -1 99 5 # SizeSel_8P_1_F8_BLK1repl_1993

```

```

-9 4 -6.21365 -3 -1 99 5 # SizeSel_8P_2_F8_BLK1repl_1993
-4 9 6.31733 6 -1 99 5 # SizeSel_8P_3_F8_BLK1repl_1993
-4 9 2.2206 3 -1 99 5 # SizeSel_8P_4_F8_BLK1repl_1993
27.5 130 126.632 89 -1 99 5 # SizeSel_16P_1_F16_BLK7repl_1985
0.01 50 8.43478 6 -1 99 5 # SizeSel_16P_2_F16_BLK7repl_1985
27.5 130 126.775 89 -1 99 5 # SizeSel_17P_1_F17_BLK7repl_1985
0.01 50 8.80571 6 -1 99 5 # SizeSel_17P_2_F17_BLK7repl_1985
27.5 130 82.2621 89 -1 99 5 # SizeSel_21P_1_F21_BLK4repl_2005
-9 4 1 -3 -1 99 -5 # SizeSel_21P_2_F21_BLK4repl_2005
-4 9 5.23708 6 -1 99 5 # SizeSel_21P_3_F21_BLK4repl_2005
-4 9 4.35583 3 -1 99 5 # SizeSel_21P_4_F21_BLK4repl_2005
#_Cond No selex parm trends
#_Cond -4 # placeholder for selparm_Dev_Phase
1 #_env/block/dev_adjust_method (1=standard; 2=logistic trans to keep in base parm bounds; 3=standard w/ no bound
check)
#
# Tag loss and Tag reporting parameters go next
0 # TG_custom: 0=no read; 1=read if tags exist
#_Cond -6 6 1 1 2 0.01 -4 0 0 0 0 0 0 #_placeholder if no parameters
#
1 #_Variance_adjustments_to_input_values
#_fleet: 1 2 3 4 5 6 7 8 9 10 11 12 13 14 15 16 17 18 19 20 21 22 23 24
0 0 1 0 0 0 0 0 0 0 0 0 0 0 0 0 0 0 0 0 0 0 0 0 #_add_to_survey_CV
0 0 0 0 0 0 0 0 0 0 0 0 0 0 0 0 0 0 0 0 0 0 0 0 #_add_to_discard_stddev
0 0 0 0 0 0 0 0 0 0 0 0 0 0 0 0 0 0 0 0 0 0 0 0 #_add_to_bodywt_CV
0.03 0.03 0.03 0.03 1 1 0.045 0.03 0.03 1 1 0.03 0.03 1 1 0.06 0.06 1 1 0.06 0.06 0.06 1 0.06 #_mult_by_lencomp_N
1 1 1 1 1 1 1 1 1 1 1 1 1 1 1 1 1 1 1 1 1 1 1 1 #_mult_by_agecomp_N
0 0 0 0 0 0 0 0 0 0 0 0 0 0 0 0 0 0 0 0 0 0 0 0 #_mult_by_size-at-age_N
#
1 #_maxlambdaphase
1 #_sd_offset
#
23 # number of changes to make to default Lambdas (default value is 1.0)
# Like_comp codes: 1=surv; 2=disc; 3=mnwt; 4=length; 5=age; 6=SizeFreq; 7=sizeage; 8=catch;
# 9=init_equ_catch; 10=recrdev; 11=parm_prior; 12=parm_dev; 13=CrashPen; 14=Morphcomp; 15=Tag-comp; 16=Tag-
negbin
#like_comp fleet/survey phase value sizefreq_method
1 8 1 1 0
1 12 1 1 0
1 1 1 1 0
1 2 1 1 0
4 1 1 1 0
4 2 1 1 0
4 3 1 1 0
4 4 1 1 0
4 7 1 1 0
4 8 1 1 0
4 9 1 0 0
4 12 1 1 0
4 13 1 0 0
4 16 1 1 0
4 17 1 1 0
4 20 1 1 0
4 21 1 1 0
4 22 1 1 0
4 24 1 1 0
9 1 1 0 0
9 8 1 0 0
11 1 1 0 1
13 1 1 100 1
#

```

```

# lambdas (for info only; columns are phases)
# 1 #_CPUE/survey:_1
# 1 #_CPUE/survey:_2
# 0 #_CPUE/survey:_3
# 0 #_CPUE/survey:_4
# 0 #_CPUE/survey:_5
# 0 #_CPUE/survey:_6
# 0 #_CPUE/survey:_7
# 1 #_CPUE/survey:_8
# 0 #_CPUE/survey:_9
# 0 #_CPUE/survey:_10
# 0 #_CPUE/survey:_11
# 1 #_CPUE/survey:_12
# 0 #_CPUE/survey:_13
# 0 #_CPUE/survey:_14
# 0 #_CPUE/survey:_15
# 0 #_CPUE/survey:_16
# 0 #_CPUE/survey:_17
# 0 #_CPUE/survey:_18
# 0 #_CPUE/survey:_19
# 0 #_CPUE/survey:_20
# 0 #_CPUE/survey:_21
# 0 #_CPUE/survey:_22
# 0 #_CPUE/survey:_23
# 0 #_CPUE/survey:_24
# 1 #_lencomp:_1
# 1 #_lencomp:_2
# 1 #_lencomp:_3
# 1 #_lencomp:_4
# 0 #_lencomp:_5
# 0 #_lencomp:_6
# 1 #_lencomp:_7
# 1 #_lencomp:_8
# 0 #_lencomp:_9
# 0 #_lencomp:_10
# 0 #_lencomp:_11
# 1 #_lencomp:_12
# 0 #_lencomp:_13
# 0 #_lencomp:_14
# 0 #_lencomp:_15
# 1 #_lencomp:_16
# 1 #_lencomp:_17
# 0 #_lencomp:_18
# 0 #_lencomp:_19
# 1 #_lencomp:_20
# 1 #_lencomp:_21
# 1 #_lencomp:_22
# 0 #_lencomp:_23
# 1 #_lencomp:_24
# 0 #_init_equ_catch
# 1 #_recruitments
# 0 #_parameter-priors
# 1 #_parameter-dev-vectors
# 100 #_crashPenLambda
0 # (0/1) read specs for more stddev reporting
# 0 1 -1 5 1 5 1 -1 5 # placeholder for selex type, len/age, year, N selex bins, Growth pattern, N growth ages,
NatAge_area(-1 for all), NatAge_yr, N Natages
# placeholder for vector of selex bins to be reported
# placeholder for vector of growth ages to be reported
# placeholder for vector of NatAges ages to be reported
999

```