

KNC Model 3666 Automatic Pressure Calibration System



Product Description

The Model 3666 Automatic Pressure Calibration (APC) System by King Nutronics Corporation is a portable secondary standards laboratory capable of generating and controlling test and calibration pressures up to 10,000 psig with an accuracy of $\pm 0.1\%$ of the indicated value (IV) throughout its operating range.

Available in four configurations, the Model 3666 APC System is designed for fast, efficient testing and calibration of pressure gauges, vacuum gauges, switches, transmitters, transducers, and other pressure sensing devices. The test system components are housed in rugged, compact aluminum cases and can be easily transported to the location of instruments requiring calibration, which simplifies service and maintenance procedures.

The 3666-2K-1 APC System operates at pressures up to 2,000 psi, and consists of a control unit, a nitrogen supply cylinder, and an accessory kit containing all equipment required for use and maintenance of the system. The 3666-10K-1, 3666-10K-2, and 3666-10K-3 APC Systems operate at pressures up to 10,000 psi, and include the control unit, nitrogen supply cylinder, accessory kit, and a separate pressure intensifier. A conversion kit enables the 3666-2K-1 APC System to be upgraded to 3666-10K-1 specifications. See below for more information regarding the APC System components.

Operation of the Model 3666 APC System is driven by microprocessor circuitry incorporated in the control unit. An alphanumeric front panel display prompts the operator through the measurement process and performs all necessary calculations, saving time and effort. Precise direct readings can be displayed using the following measurement units: psig, inches of mercury, inches of water, feet of seawater, kilopascals, and kilograms-per-square-centimeter. A handheld remote control module displays measurements and enables operation of the test set up to 10 feet from the control unit.

A convenient thermal printer built into the control unit can be used to generate hard copies of test and calibration data, eliminating time-consuming manual data logging. The control unit also incorporates an IEEE-488/GPIB interface, permitting automated calibration of the 3666 APC System using the King Nutronics 3689-A Precision Pressure Standard System. Quick-disconnect fittings are used on all pneumatic connections, enabling fast system setup.



Control Unit

The Model 3666 APC control unit contains the electronics that drive the system, all operator controls and interfaces, and a thermal printer.

During operation, the control unit accepts pressurized dry nitrogen from a supply cylinder or pressure intensifier, or vacuum from an external source, and meters precisely controlled pressure or vacuum to the unit under test, as shown in the diagram below. In "normal mode" the control unit electronics permit coarse and fine adjustment of the delivered pressure/vacuum for faster testing. The operator can also specify a tolerance range and pass/fail criteria for the pressure/vacuum delivery. In the "calibration lab" mode, pressure/vacuum is delivered at the exact level specified by the operator.



An easily readable vacuum-fluorescent front panel display provides information such as the target pressure, actual pressure, and pass/fail status for the unit under test. Hard copies of test and calibration results can be quickly generated using the built-in printer.

A self-test of the electronic components is executed each time the 3666 APC control unit is powered-up. If a malfunction is detected, its cause and location is shown on the front panel display, simplifying service.

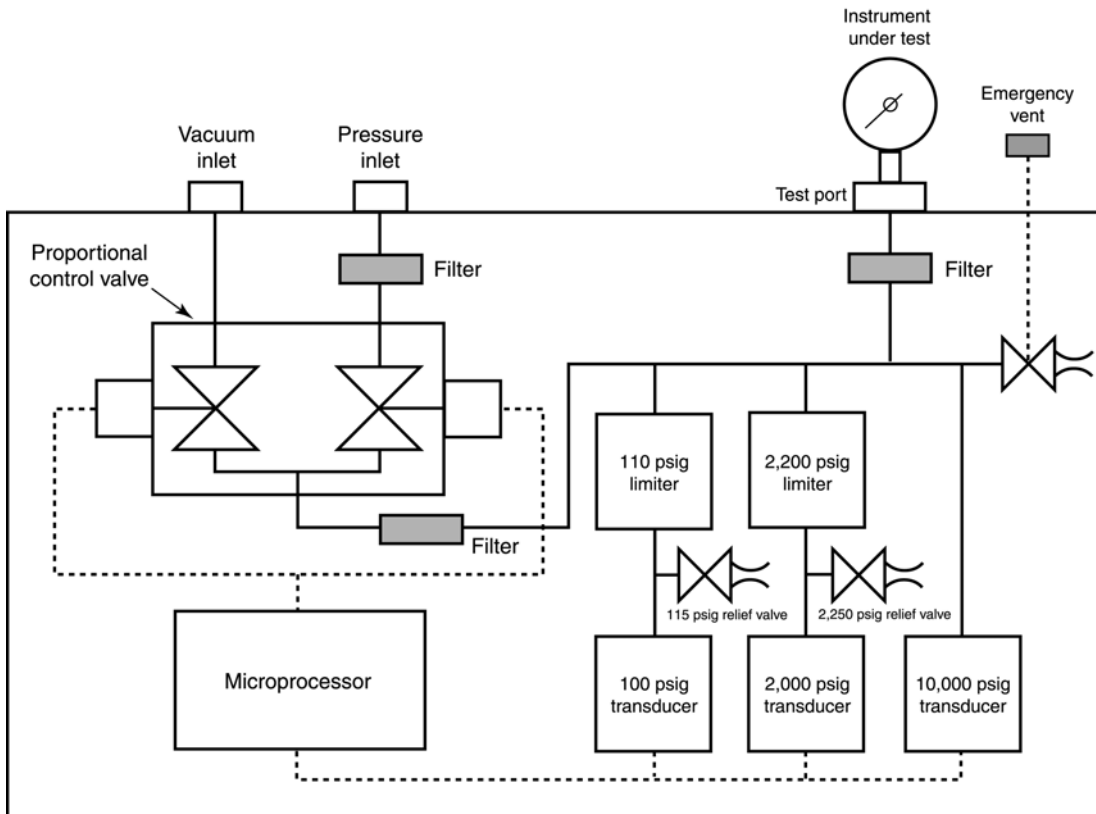

Pressure Intensifier (P/N 3666-17-1)



The Model 3666-17-1 Pressure Intensifier is an electrically powered device that accepts low pressure gaseous nitrogen from 500 to 2,216 psi and boosts the pressure up to 10,000 psig in 1,000 psig increments for use by the Model 3666 APC control unit.

During operation, pressure from a motor-driven hydraulic pump is routed to a booster pump containing a differential area piston, as shown in the diagram below. Hydraulic pressure applied to the large end of the piston drives it forward to compress the supplied nitrogen in the small end. The compressed nitrogen is routed to an accumulator, and the pumping cycle is repeated until a transducer senses that the desired pressure has been reached in the accumulator.

Check valves prevent the flow of compressed nitrogen back to the supply cylinder or the escape of gas from the accumulator while the piston cycles. No gas is consumed during operation, which conserves the nitrogen in the supply cylinder.

Discharge pressure from the accumulator is set in 1,000 psi increments via a PRESSURE SET switch on the front panel of the unit, which controls the cycling of the booster pump based on the signals from the transducer. A pressure gauge permits the operator to monitor the pressure in the accumulator during operation.

A front panel-mounted PRESSURE valve allows the operator to control the delivery of gas from the accumulator discharge port to the Model 3666 APC control unit, while a VENT valve permits pressure in the discharge line to be safely vented without disturbing the hose connections.

The Model 3666-17-1 Pressure Intensifier requires minimal maintenance. A dipstick and OIL LEVEL CHECK switch mounted on the front panel permit convenient monitoring and topping-up of the hydraulic oil used to drive the booster pump without removing the chassis from the case.

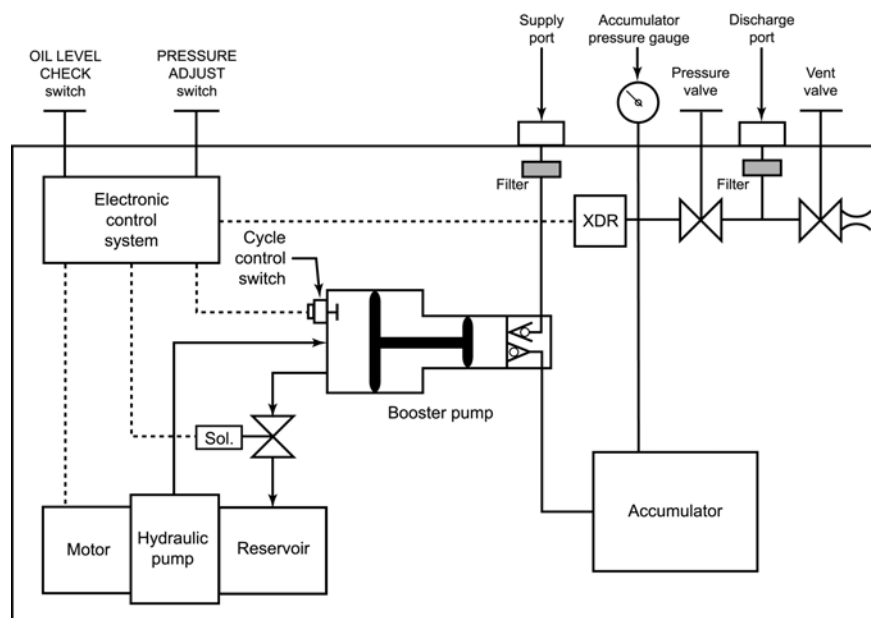

Accessory Kit

All equipment necessary for operation of the 3666 APC System is housed in a rugged aluminum carrying case lined with shock-absorbent material. Accessories included with the Model 3666 APC System include high pressure delivery hoses, a low pressure supply hose, a jumper hose (P/N 3666-10K-1, 3666-10K-2, and 3666-10K-3 only), two fluid separators, a liquid trap, and an adapter kit containing an assortment of quick-disconnect fittings compatible with most gauges and pressure switches encountered in the field. All hoses included with the APC System are terminated with high quality quick-disconnect fittings for simple equipment setup. A continuity tester is also included for testing the actuation of pressure switches.



In addition, the Accessory Kit includes a selection of spare parts required for maintenance of the Model 3666 APC System, such as packings and seals for the control elements and a spare printer tape.

Nitrogen Supply Assembly

The Nitrogen Supply Assembly for the Model 3666 APC System consists of a compact aluminum gas cylinder conforming to ICC and DOT regulations, a shrouded manifold assembly, and a heavy-duty nylon retaining belt. The cylinder capacity is 60 scf of gaseous nitrogen at 2,216 psi.

The manifold assembly incorporates a pressure gauge for convenient monitoring of the nitrogen supply, a bleed valve for venting the supply hose prior to being disconnected, and a rupture disc for safety. The manifold outlet is terminated with a quick-disconnect fitting for simple connection to the supply hose.

Handheld Remote Control Module

The handheld remote control module plugs into a jack on the front panel of the control unit and duplicates a number of functions and displays, enabling the operator to perform tests and measurements from up to 10 feet away from the Model 3666 APC System.

The remote control module incorporates two LED displays for the target and actual pressure and LED indicators that allow the operator to monitor the pass/fail status of a test. Advance, Measure, and Abort keys on the remote control module, and an Increase/Decrease touch-sensitive panel provide fingertip control of the test process.

The remote control module is stored in the control unit case lid for convenience.



General Specifications

Characteristics	Specifications
Temperature range: Operating Storage Humidity (operating)	+10° to +50° C -55° to +75° C 5 to 90% RH, from 0°C to +50°C
Fluid medium	Dry nitrogen or other inert gas
Port configuration	Quick-disconnect coupling
Case type/construction	Heavy-duty drawn aluminum with removable lid
Case color	FED-STD-595, Color 13531
Case dimensions, inches (W x H x D)	18 x 12 x 11
System shipping weight (approx.): P/N 3666-2K-1 P/N 3666-10K-1	175 lbs. 225 lbs.

Control Unit Specifications

Characteristics	Specifications
Range: P/N 3666-2K-1 ¹ P/N 3666-10K-1 ¹ P/N 3666-10K-2 ² P/N 3666-10K-3 ²	25 in-Hg vacuum; 0 to 2,000 psig (two quartz transducers) 25 in-Hg vacuum; 0 to 10,000 psig (three quartz transducers) 25 in-Hg vacuum, 0 to 10,000 psig (three strain gauge transducers) 25 in-Hg vacuum, 0 to 10,000 psig (three strain gauge transducers)
Accuracy: 0 to 5 psig 5 to 10,000 psig Vacuum Absolute	0.005 psig max. error 0.1% IV 0.2% IV or ±0.02 in-Hg, whichever is greater 0.1% IV above 10 in-Hg absolute
Resolution: Below 100 psig 100 to 1,000 psig 1,000 to 10,000 psig	0.001 psig 0.01 psig 0.1 psig
Display	Alpha-numeric vacuum-fluorescent
Input power: Voltage Fuse type	115 VAC, 50-60 Hz 3AG, 2 Amps
Weight	34 lbs.

¹ Type 3666 Control Unit.

² Type 3666C Control Unit

Pressure Intensifier Specifications (P/N 3666-17-1)

Characteristics	Specifications
Type	Electric motor driven
Discharge pressure	1,000 to 10,000 psig (adjustable)
Minimum supply pressure	500 psig
Input power: Voltage Fuse type	115 VAC, 50-60 Hz 3AG, 2 Amps
Oil Capacity Type	34 oz MIL-H-5606
Weight	45 lbs.



Nitrogen Supply Cylinder Specifications

Characteristics	Specifications
Type	ICC-3AA (aluminum cylinder)
Operating pressure	2216 psig
Capacity	60 scf at 2216 psig
Dimensions, inches (nominal):	
Diameter	7.25
Height	28
Weight	30 lbs.

Accessory Kit Specifications

Characteristics	Specifications
Part no.:	
2,000 psi system	3666-6-1
10,000 psi system	3666-6-3
Weight	32 lbs.
High pressure hoses (qty. 2):	
Standard length	10 feet
Pressure:	
Operating	3,000 psig
Proof	4,500 psig
Burst (minimum)	12,000 psig
Construction	Teflon-lined stainless steel
End configuration	High pressure quick-disconnect, female-to-male termination
Supply hose:	
Standard length	5 feet
Pressure:	
Operating	3,000 psig
Proof	4,500 psig
Burst (minimum)	12,000 psig
Construction	Teflon-lined stainless steel
End configuration	High pressure quick-disconnect, female-to-female termination
Fluid separator assemblies:	
Pressure:	
Operating	10,000 psig
Proof	15,000 psig
Burst (minimum)	40,000 psig
Capacity	3.0 cubic inches (fluid side)
Port configuration	High pressure quick-disconnect, one female, one male
Standard diaphragm material	Buna-N
Maximum error	0.01 psig
Liquid trap:	
Capacity	0.5 cubic inches
Operating pressure	10,000 psig
Port configuration	High pressure quick-disconnect
Jumper hose (10,000 psi system only):	
Standard length	5 feet
Pressure:	
Operating	10,000 psig
Proof	15,000 psig
Burst (minimum)	40,000 psig
Construction	Stainless steel capillary sheathed in Teflon-lined braided stainless steel hose
End configuration	High pressure quick-disconnect, male-to-male termination

