

UNCLASSIFIED

AD 402 626

*Reproduced
by the*

DEFENSE DOCUMENTATION CENTER

FOR

SCIENTIFIC AND TECHNICAL INFORMATION

CAMERON STATION, ALEXANDRIA, VIRGINIA



UNCLASSIFIED

NOTICE: When government or other drawings, specifications or other data are used for any purpose other than in connection with a definitely related government procurement operation, the U. S. Government thereby incurs no responsibility, nor any obligation whatsoever; and the fact that the Government may have formulated, furnished, or in any way supplied the said drawings, specifications, or other data is not to be regarded by implication or otherwise as in any manner licensing the holder or any other person or corporation, or conveying any rights or permission to manufacture, use or sell any patented invention that may in any way be related thereto.

633-3

TM-1042/104/00

CATALOG OF ASTIA

AD No. 402626

TECHNICAL MEMORANDUM

(TM Series)

ASTIA AVAILABILITY NOTICE

Qualified requesters may obtain copies of this report from ASTIA.

This document was produced by SDC in performance of U. S. Government Contracts

A Simplified Queueing Model
for the 465L System
by
S. Gorenstein
March 15, 1963

SYSTEM
DEVELOPMENT
CORPORATION
2500 COLORADO AVE.
SANTA MONICA
CALIFORNIA

The views, conclusions or recommendations expressed in this document do not necessarily reflect the official views or policies of agencies of the United States Government.

Permission to quote from this document or to reproduce it, wholly or in part, should be obtained in advance from the System Development Corporation.

Although this document contains no classified information it has not been cleared for open publication by the Department of Defense. Open publication, wholly or in part, is prohibited without the prior approval of the System Development Corporation.



ASTIA
RECEIVED
MAY 3 1963
RECEIVED
TISIA

TABLE OF CONTENTS

	Page
1. <u>INTRODUCTION</u>	3
2. <u>THE MESSAGE PATH</u>	9
3. <u>THE DISTRIBUTION FUNCTION OF THE TIME IN THE SYSTEM</u>	22
4. <u>LAPLACE-STIELTJES TRANSFORMS OF THE VARIOUS DISTRIBUTION FUNCTIONS</u> . 29	29
5. <u>SUMMARY AND CONCLUSIONS</u>	30
APPENDIX I. AVERAGE WAIT OF AK MESSAGE IN EDTTCC OUTPUT QUEUE TO RCC	32
APPENDIX II. DERIVATION OF THE DISTRIBUTION FUNCTION AND ERROR ESTIMATE	35
APPENDIX III. MOMENTS	43
APPENDIX IV. UNEXPENDED SERVICE TIME FOR EXPONENTIAL SERVICE . . .	47
GLOSSARY	48
REFERENCES	53

A SIMPLIFIED QUEUEING MODEL FOR THE 465L SYSTEM

by

S. Gorenstein

1. INTRODUCTION

1.1 DESCRIPTION OF SACCS

The Strategic Air Command Control System (SACCS, Air Force number 465L) consists of a data- and communications-transmission network, computer-based data- and communications-processing centers, and data-display complexes. The data-transmission network will interconnect a system of computer-based data centers (Data Processing Centrals or DPC's), communications-processing centers (called Electronic Data Transmission Communications Centrals, or EDTCC's), many remotely located message-input and message-output centers (called Remote Communications Centrals, or RCC's), and Simplex Remote Communications Centrals (SRCC's). Each command post feeds information about local aircraft and missile status and disposition, logistics, maintenance, weather, and missile and aircraft readiness, into its designated RCC or SRCC.

Messages are introduced into the system by manually operated input keyboards. In addition, messages may also be introduced directly and automatically from other equipments and systems. Messages are automatically converted into digital-computer language, encrypted or decrypted by cryptographic equipment, converted to or from digital form into audible frequencies by a modulator-demodulator (Data Modem), and transmitted or received. RCC's can communicate with each other through EDTCC's. However, their main function is that of exchanging information with the main command post by means of EDTCC's.

March 15, 1963

4

TM-1042/104/00

An EDTCC* forms a nucleus for a larger group of RCC's and SRCC's. Each of the four zone-of-interior headquarters bases has an EDTCC that serves as a central control for the outlying RCC's and SRCC's. Messages are received from and sent out to each communications central through the facilities of the EDTCC. When a message is received, it is automatically checked for validity and then transferred to temporary and/or permanent storages. All incoming messages to the EDTCC are automatically switched and routed to the designated locations. Pertinent information is automatically transferred to the on-line computer (DPC) by the EDTCC for filing and updating. Each EDTCC contains a programmed message-switching device which can receive messages, analyze them as to their disposition, and then route them to RCC's, computer (DPC's), or the display devices.

The data displays are accomplished by the Data Display Central (DDC).

From the RCC input keyboard, messages enter the system at the various wings and squadrons and the information flows through the EDTCC, wherein messages are routed to the next appropriate point in the system. If the messages are formatted, the information will flow to the DPC, where it will be used to update specific files. In some cases, the information will force specific displays which will bring to the attention of control personnel at SAC and Numbered Air Force Headquarters the existence of deviant situations requiring their attention and possible further action.

* We have simplified the discussion of the EDTCC by avoiding detailed description of its sequences and their priorities. These are more fully covered in reference (6).

1.2 PURPOSE OF THE STUDY

The purpose of this study is to make a preliminary investigation of the time it takes, under EWO conditions, for information to be displayed from the time of entry into the 465L system. That is, if a message is ready to be entered into a RCC at an airbase, what can we say about how long it will take until it is displayed at SAC headquarters? The problem as posed above really encompasses many problems since not all messages go through the same equipment configuration, and different types of messages may follow different paths through the same equipment. Here only one particular kind of message will be examined: one that enters a RCC, passes through two EDTCC's,* is processed by the DPC and then becomes part of a wall display (see Figure 1).

The second EDTCC enters the path again because all displays are transmitted by the DPC through its associated EDTCC. This path will cover a variety of message types, that is, the kind that requires information from bases to build up a wall display. Probably most of the messages of the system fall into this class.

The system is a very complicated one and has operating rules that would be difficult and time-consuming to incorporate into a model that would exactly describe the system behavior. In order to get a feel for the times involved and an approximation to the system's behavior, a simplified model is here

* Note: It has been proposed that almost all RCC's have a primary connection to the headquarters EDTCC. This would remove EDTCC #1 from the message path and reduce the time in the system. The analysis would not be affected. The waiting and service times contributed by EDTCC #1 would simply become zero.

March 15, 1963

6

TM-1042/104/00

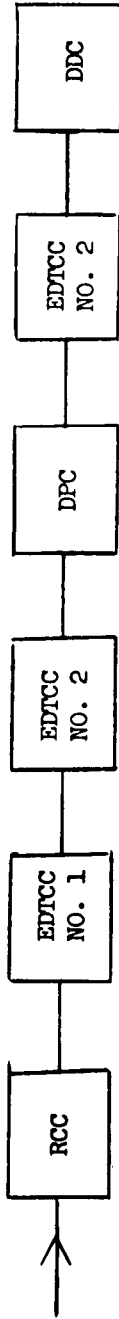

Figure 1. MESSAGE PATH CONSIDERED HERE

March 15, 1963

7

TM-1042/104/00

adopted, one that lends itself to analysis, because much more is known about its behavior than about one based on other assumptions.

The prime assumption made is that messages enter the system according to the Poisson law, and wait in turn for an exponential service at each service stage. In this case, the departures from a service unit again obey the Poisson law (for single or multichannel service) with the same parameter as they did when they came to the service unit. (See references 3 and 9.)

The physical process described by the Poisson law can be viewed as follows: instantaneous changes of state can occur at any time; these changes are due to the occurrence of a random event (in our case, generation of a message) and we are interested in the total number of messages. We are assuming the process is stationary (those forces influencing the system remain unchanged with the passage of time; this will be true, for example, during an Emergency War Order (EWO) condition, while not true in general) and future changes are independent of the past. See reference (5), pp. 364 and following, for a more complete description. It has been shown that telephone traffic can be approximated by the Poisson law, and that the length of telephone conversations follows the exponential law (see reference 5, pp. 218 and following). Use of the exponential distribution for 465L is a pessimistic assumption in that it assigns probabilities to longer messages than can exist in the system. No attempt is made here to justify these assumptions for the 465L system, but they do appear to introduce reasonable and mathematical simplifications.

By this assumption, the same Poisson arrival process is repeated for each servicing element. If there are several sources feeding an element, each obeying

the Poisson law with different parameters, the sum obeys the Poisson law with parameter equal to the sum of the individual parameters. We are thus led to a tandem queueing process where the sum of times spent in the various units will yield the time in the system.

We assume that each of the queueing processes which form the whole system is in the stationary state. This state will exist if the input rate, λ , is less than the service rate, μ , or $\frac{\lambda}{\mu} = \rho < 1$. Should this condition not be met, queues will become infinite, as will the waiting time.

Without the Poisson-exponential assumptions, the problem becomes formidable, since further analysis is required to determine the output distribution resulting from other input and service distributions.

The effect of the priority assigned to alert messages is not considered, since EWO starts after the alert.

The above program is substantially followed in the ensuing sections. It is recognized that this does not result in an exact description of the system. We hope to extend the investigation in subsequent documents and obtain output distributions under different assumptions.

The present results will appear in two documents. This one, which contains general results for arbitrary parameters, and another which will be classified and will contain specific figures for the estimated message traffic and service times.

2. THE MESSAGE PATH

2.1 A DIAGRAM OF THE MESSAGE PATH

Figure 2 is a chart of the message path considered, showing where queues may occur. Each box does not represent a complete piece of equipment, but a service point of the system, and may include parts of different equipment complexes. Notations above the chart show where the equipment starts and ends, and also cover interactions of equipment.

Where a box is in dotted lines, it refers to a service which involves equipment interaction.

Queues form where there are lines joining boxes. Where boxes are adjacent to one another, no queues have been considered.

The numbers in the boxes are the same as those in the list (Section 3) of waiting and services times being summed.

Where the number is followed by A, this time is not included in a message's time in the system but does contribute to a waiting time the message may have to undergo.

2.2 A DESCRIPTION OF THE MESSAGE PATH

A message is entered into a RCC keyboard and is transferred to that keyboard's line store for transmission. It then goes through the RCC to an EDTCC. Before the next message can be transmitted from the RCC, the previous one must be acknowledged by the EDTCC. The message is then transmitted to the headquarters)* and thence to the DPC, which updates the data files that make up the displays.

* See note on page 3 .

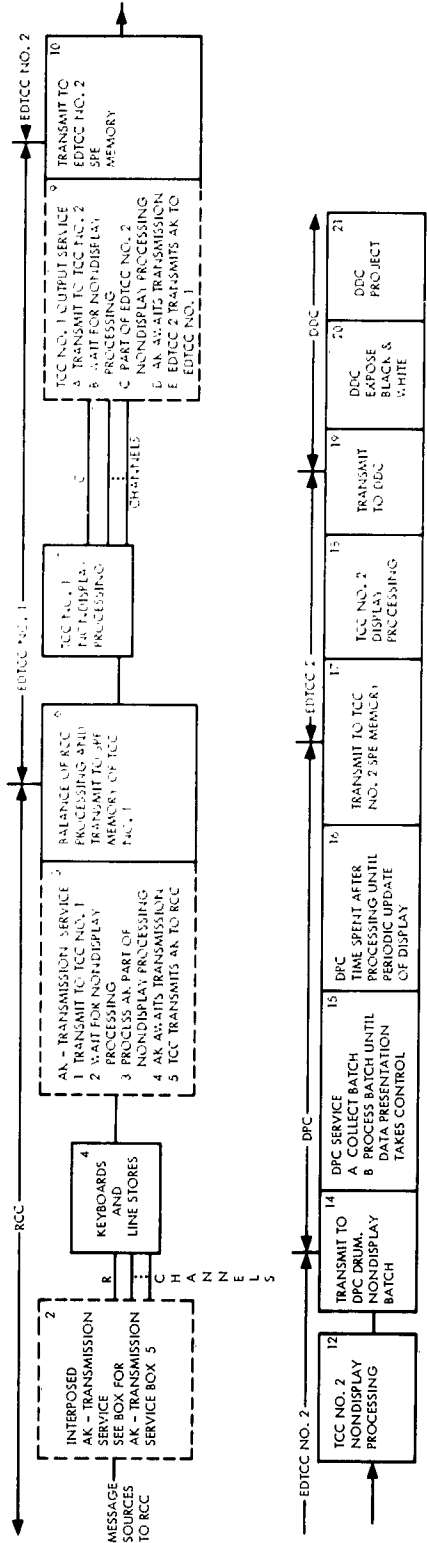

FIGURE 2 QUEUES CONSIDERED IN MESSAGE PATH

March 15, 1963

11

TM-1042/104/00

Wall displays are transmitted from the DPC through the headquarters EDTCC to the DDC and projected.

The following is a more detailed description of the path of a message of the type considered.

The message is considered to enter the system the moment it is in the form of a message, that is, when it is ready to be entered into a RCC (or SRCC) keyboard. The keyboards may be located at the RCC or remotely located at TSA (Subscriber A) equipment which is serviced through a RCC. The RCC keyboards (including the associated TSA keyboards) are considered as a multiple-channel service point, and messages queue in front of them for service (entry into the system through the keyboard). The message is transferred from the keyboard to its associated line store, and may have to wait for transmission to the stored program element (SPE) of the EDTCC.

Transmission from the line store is in a prescribed order, #1, #2, etc.,* and can take place only after an acknowledgement is received from the EDTCC for the transmission of the previous message. (This disturbs the first-come, first-served process, but the effect will be negligible, and is not considered in the model.) The keyboard can accept another message only after its previous message has been acknowledged. The multiple-channel (keyboards), first-come, first-served queue at the RCC does not exactly describe the situation and is a bit

*Keyboards #1 and #2 may have priority buttons, which when depressed cause the message seeker to return to line store #1 after completing its current transmission from a line store.

optimistic since, while it may be true that at the TCC itself an alternate keyboard can be used to service a queue, remote keyboards are not available for locally generated messages and vice versa.

Also, there is another difficulty. The first message in a queue may be denied access to a keyboard, not only because they are all being used (the usual queueing waiting time) but also because one or more line stores contain unacknowledged messages while the other keyboards are being used, which means some keyboards are locked while messages are waiting to be entered.

Since the additional delay, when it occurs, amounts to the time to receive and acknowledge messages, we will account for this effect in the model by having each message pass through an acknowledge-transmission service before its entry into the keyboard. This will more than compensate for any blocking delay that may occur.

The message, after it enters the line store, awaits the service of messages in lower-numbered line stores and may be preceded by an AK message which the RCC has to send to the EDTCC. Since the latter are only two-character messages, the processing will be very fast, so we can safely ignore its effect. (However it can be taken into account by adding to the service time an amount computed as follows:

Let λ_{RT} be the message-traffic rate from RCC to EDTCC, and λ_{TR} be the message-traffic rate from EDTCC to RCC. Then, the average service time can be increased by

$$\frac{\lambda_{TR}}{\lambda_{RT}} \times \text{time to process 2 AK characters}$$

since each message from EDTCC to RCC will require an AK from RCC to EDTCC.)

March 15, 1963

13

TM-1042/104/00

The message, therefore, goes through what might be called an AK-transmission service and must wait for the AK-transmission service of messages ahead of it. We ignore the minor effect of this AK-transmission service not being first-come first-served; otherwise each keyboard would require separate treatment. (We also assume that the effect of limited queuing space in the line store has been accounted for by the AK-transmission service injected to account for locked keyboards.)

However, it is not necessary to include an AK time for the message in the total time in the system, since a particular message's AK time is not part of its time in the system. It affects only the messages behind it.

The AK-transmission service consists of the transmission to the EDTCC, the EDTCC processing of the AK message, its transmission to the RCC, and the time it takes for the RCC to recognize the AK and start transmission of the next message.

The message then goes through the balance of the RCC processing (link serial-digit generator, horizontal-parity generator, etc.) and is transmitted to the SPE memory (via the EDTCC line unit, input core memory, data buffer).

We account for the interruptions to the output due to AK's from RCC to EDTCC in the manner noted above.

We assume that whatever errors are introduced by overwriting of characters in the EDTCC input core memory are covered by an adjustment of RCC service time. This may also add to blocking, so the number of interposed AK services will be adjusted to account for repeats. According to reference (6), which assumes the same traffic rates as those in reference (2) for the first hour after the alert, it is highly unlikely that there will be such errors, since the EDTCC

March 15, 1963

14

TM-1042/104/00

seems to be able to accept characters from the data buffer quickly enough to prevent overwriting in the input core memory.

We are dealing with a message that will eventually affect a wall display and we assume that it will have to go through two EDTCC's,* #1 and #2. Each EDTCC performs two kinds of processing, nondisplay and display, the former for transmitting messages and the latter for transmitting displays from the DPC to the DDC. The message will have to receive the nondisplay processing in EDTCC #1.

Nondisplay messages (except for alert messages) are processed first-come first-served. Processing consists of message validation, message logging (and generating AK message), addressee interpretation, and assignment of output lines. The AK message is generated early in the processing. Thus, its processing time is less than the processing time of the message that is generating it.

Display messages have priority in processing over nondisplay messages. However, the effect of this priority will depend on how displays are treated in the system. If there is a ready store that is updated in the EDTCC, the number of display messages from the DPC to update the ready store will be larger than if there is no ready store when the volume of display messages will be small and its priority effects can probably be safely ignored. In this model, we will not consider the priority effects, even if there is a ready store

* See note on page 3.

March 15, 1963

15

TM-1042/104/00

since it probably will not be constantly updated, and the DPC batch processing should limit the number of display messages to the EDTCC in any case. The priority effect will be calculated in a later paper.

Therefore, for the nondisplay processing, we will consider both types as one. This will be slightly optimistic, since the display priority will increase the nondisplay waiting time, but for a small volume this increased delay should be negligible. It will be considered in a later paper, if the traffic volume seems to warrant it.

The generated AK message and the outputs to addressees are assigned to output lines. The AK message goes to the head of the queue (if any) for the output line to which it is assigned but does not interrupt a transmission. The addressee outputs join a queue (if any) awaiting transmission from EDTCC #1. There may be a priority system for EDTCC outputs, other than for the alert message, but this has not been decided yet and is not considered here. Outputs to EDTCC #2 can go over two, four, or six channels, and the AK-transmission service is considered to be:

The transmission to EDTCC #2 (multiple channel).

EDTCC #2 processes AK.

EDTCC #2 transmits AK (multiple channel).

EDTCC #1 recognizes AK.

As in the RCC, we also consider the interruptions here are due to AK's going to EDTCC #2.

March 15, 1963

16

TM-1042/104/00

The EDTCC output differs from that of the RCC, since here the output service can take place over multiple channels, while in the RCC there is only one transmission line over which the message can travel and one over which the AK can be received. Thus, the output to EDTCC #2 can be considered a c-server process with its Poisson arrival rate.

The AK time (which is needed for the waiting time in the RCC line store and for the waiting time of an EDTCC output to an EDTCC) thus consists of:

Wait for nondisplay processing.

Part of the nondisplay processing.

Wait for completion of transmission of message being transmitted, if any, to RCC (EDTCC).

Transmission to RCC (EDTCC).

RCC (EDTCC) recognizes AK.

The message then goes to EDTCC #2* where it again receives a nondisplay processing as in EDTCC #1 and may, as mentioned, encounter a priority system for outputs. However, the output this time joins the queue to the DPC. The transmission takes place one word at a time on receipt of a data demand signal from the DPC. Since we are concerned with a DPC operation for EWO, DPC will be constantly doing control functions. Therefore, it is assumed data will always be accepted by the DPC and stored in a drum field for regular messages. Here we consider a transmission to the DPC drum as a service. The message arrives at the DPC and is collected in the drum field with other nondisplay messages until the DPC processing of the previous batch is completed. Thus, the batch

*See note on page 3 .

collection time is the same as the entire processing time for the previous batch. Since the latter is assumed to be exponentially distributed, it follows (see Appendix IV) that the unexpended processing time has the same distribution. The unexpended processing time is the time that a message must stay in a batch (average α_{BC}).

It may happen that the DPC outputs will be generated during the batch processing, or at the completion of a batch's processing. If the former, the batch-processing time (average α_{BP}) for that particular display which our message will affect will be less than the entire batch-processing time (average α_{BC}). Otherwise, it will be the same.

The batch receives its processing and it is recommended that the resulting displays should be noted in a display-output table. Then, data presentation takes control (or it may come in during a batch's processing), and displays are output to the EDTCC destined for the DDC.

Since it is uncertain at present how the ready store will operate, we will not consider its effect on the system. But a crucial part of the system is the way displays arrive at the DDC (see references (10) and (12)). We now have to deal with outputs to the DDC wall displays (see reference (10) for a complete description of DDC operation). Here, the processing is complicated and, for the first time in this analysis, we do not use the Poisson-exponential assumptions. The DDC wall displays can be considered as a two-stage service, expose and then process, each with a constant holding time. All displays must go through the expose stage before proceeding to the second, the group display generators (GDG). (There are three or four GDG's.) However, each display can

March 15, 1963

18

TM-1042/104/00

be projected only by a designated half of a GDG, and if a display is awaiting expose service, it cannot enter service unless the half of the GDG which projects it is free. If it cannot enter, it blocks all those behind it, and as indicated in references (10) and (12), circumstances might arise under which infinite queues build up.

It is, therefore, extremely important that the displays are output from the DPC display-output table in such a manner that blocking does not occur. In this table there will be merged those displays requiring periodic updates, those forced in the processing by system criteria (comparison between system's actual state and some requirements, a particular message, etc.), and requested displays. They should be output so that the six or eight halves of the GDG's are addressed in order, that is, displays destined for the same GDG half should be spaced so that they have in between them displays for the other halves. In addition, some minimum time between the same outputs should be imposed for the nonperiodic outputs. This will prevent the build-up of queues to the DDC by requests or forced displays that repeat one another within a short period of time. Another benefit is that displays will not take place so fast that an observer cannot absorb the information and is only distracted by a flickering screen. If this is done, there will be no blocking.

Since the printout-display traffic is light and the EDTCC display processing is fast, printout displays can be merged into a DPC-display-output schedule so that there is no waiting in the EDTCC for display processing (or, this wait will be small and can be ignored).

This whole area requires further study so as to:

- 1) establish a periodic update schedule.
- 2) establish minimum times between updates.
- 3) determine merits of having or not having a ready store.

This latter decision can be extremely important since one can substantially reduce the traffic to the EDTCC and DDC by scheduling outputs from the DPC output table, and obviate the use of the ready store entirely.

It is obviously advantageous to keep the displays in the DPC as long as possible before the actual projection, so that it is up-to-date when transmitted and so that traffic to the EDTCC is reduced by combining outputs of the same display if they come close to one another, that is, within the minimum time between updates or during a delay while other displays are being transmitted.

At this time, it is not known how the display outputs will be programmed, so we will assume they will be programmed in this manner, that is, so that there is no blocking.

We are interested in the time spent in the DPC from the completion of processing until the periodic display is transmitted. The processing of the data in the message with which we are concerned will be completed somewhere in the interval between the periodic transmission, and we assume it is equally likely to happen anywhere in that interval, that is, it follows a uniform distribution over α seconds, where α seconds is the time between periodic updates. Let R be the time the message data is held before transmittal as a display.

Then,

$$\begin{aligned}
 P[R \leq x] &= \frac{1}{\alpha} xH(x) - \frac{1}{\alpha} (x-\alpha) \Pi(x-\alpha), \text{ or} \\
 &= \frac{x}{\alpha}, \quad 0 \leq x \leq \alpha \\
 &= 1 \quad x > \alpha,
 \end{aligned}$$

where the function H is defined as

$$\begin{aligned}
 H(x) &= 1, \quad x \geq 0 \\
 &= 0, \quad x < 0.
 \end{aligned}$$

The result of this heuristic argument is proved by Wishart (14). Then, when the time comes for it to be displayed, it will be transmitted to the EDTCC and thence to the DDC. We assume that there will be no delay in the transmission, that is, that message traffic from DPC to EDTCC will be light and will not interfere (i.e., be assigned a lower priority) with display traffic. It is also assumed that the EDTCC will be able to accept displays from the DPC as generated, since the traffic will be controlled as described above, and it will be in the DPC input sequence often enough so that the delay, if any, will be negligible. It goes through an EDTCC display processing and to the output line to the DDC. Since the DPC has already scheduled the outputs, there should be no queues after leaving the DPC, since displays have a priority in the EDTCC, and they are coming out in sequence.

Thus, the assumptions made that the display outputs from the DPC will be ordered according to the GDG half to which they are addressed, and a minimum time between outputs set so that there will be no queue, lead to a constant

time from leaving the DPC to projection at the DDC. This constant time is the sum of the various times designated by β listed in the next section, numbers 17 through 21.

2.3 REMARKS ON PARAMETRIC DATA

The traffic rates are given parametrically, and studies have been going on to determine what these are. In addition to the message traffic, there will be additional traffic generated by errors. That is, for example, if a message from an RCC arrives at an EDTCC with an error, the EDTCC will request a repeat. This means that the message will remain at the RCC until the EDTCC receives it correctly or it is directed to an alternate EDTCC. In our model this extra transmission will be considered as an addition to the AK-transmission service, that is, the average AK-transmission service will be increased to account for the error-generated traffic.

Another effect of errors would be to possibly keep keyboards locked while the same message and its AK were travelling back and forth (limit three times for one EDTCC before switching to another EDTCC). Therefore, the interposed AK service before the RCC keyboard might not be enough to account for locked keyboards under high error rate conditions. However, if error probabilities are known, then the average number of AK's per message can be determined, and that many AK services can be interposed before the RCC Keyboard.

For example, if the error rate is 5%, then 5% of the messages leaving the RCC will arrive in error and require retransmission. Then the transmission-acknowledge service time will be increase by 5% and each message will require

1.05 AK's instead of one. Therefore, 1.05 AK services will be interposed before the RCC keyboard to account for locked keyboards.

Also, reliability questions have not been considered; that is, we assume an operating system in a working state.

3. THE DISTRIBUTION FUNCTION OF THE TIME IN THE SYSTEM

We now proceed to calculate the distribution function of the time in the system. It was originally intended to sum all the waiting and service times with the use of LaPlace-Stieltjes transforms of the distribution functions, but since there were so many involved, it was decided to make use of the Central Limit Theorem. Let X_1, X_2, \dots, X_n be independent random variables, with means m_i and variances σ_i^2 , possessing absolute central moments of the order $2 + \delta$, $\delta > 0$,

$$\mu_{2+\delta}^{(1)}, \mu_{2+\delta}^{(2)}, \dots, \mu_{2+\delta}^{(n)}$$

Let

$$Y = \sum_{i=1}^n X_i$$

$$\sigma_{(n)}^2 = \text{Variance } \sum_{i=1}^n X_i = \sum_{i=1}^n \sigma_i^2$$

$$m = \sum_{i=1}^n m_i$$

If the limit, for any positive δ ,

$$\lim_{n \rightarrow \infty} W_{n, \delta} = \frac{\mu_{2+\delta}^{(1)} + \mu_{2+\delta}^{(2)} + \dots + \mu_{2+\delta}^{(n)}}{\sigma(n)^{2+\delta}} = 0,$$

then the probability of the inequality

$$\frac{Y - m}{\sigma} \leq t$$

tends uniformly to the limit

$$\frac{1}{\sqrt{2\pi}} \int_{-\infty}^t e^{-\frac{u^2}{2}} du.$$

(See Uspensky 13.)

In other words, the distribution function of the standardized sum of the random variables is asymptotically normal.

In Appendix III it is shown that the distribution functions we are dealing with do meet the limit condition above. It, therefore, seems reasonable to assume that some finite sum will be approximated by the normal distribution. Appendix II contains a derivation of the distribution function used to approximate the sum of the times in the various parts of the system, and a bound on the error introduced by using the normal distribution to approximate the finite sum of random variables. As derived in Appendix II, the probability that the time spent in the system by the data in the message from entry to wall display is less than or equal to x is equal to $F_S(x)$,

$$F_s(x) = \Phi\left(\frac{x-m-\beta-\alpha}{\sigma}\right) + \frac{\sigma}{2} \left\{ \frac{x-m-\beta}{\sigma} \left[\phi\left(\frac{x-m-\beta}{\sigma}\right) - \phi\left(\frac{x-m-\beta-\alpha}{\sigma}\right) \right] - \phi\left(\frac{x-m-\beta-\alpha}{\sigma}\right) + \phi\left(\frac{x-m-\beta}{\sigma}\right) \right\}$$

where $\Phi(x)$ is the normal distribution function and $\phi(x)$ the normal density function, with mean 0 and variance 1, and can be easily calculated from available tables. m is the sum of the means of the various exponential service times and waiting times, $\frac{\alpha}{2}$ the mean of a uniform distribution, and β the sum of the constant delays in the system. Should it turn out that the bound on the error caused by using the normal approximation is not small enough, it will be possible to compute the distribution by means of the LaPlace-Stieltjes transforms. (Section 4.) Since there are so many, the computation will be time consuming, and the resulting distribution will be complicated, thereby requiring more computations to obtain probabilities.

The times to be summed are the following:

DESCRIPTION	DISTRIBUTION FUNCTION	MEAN
1. Waiting time before interposed EDTCC No. 1 AK service to account for locked keyboards.	$1 - \rho_{TA} e^{-\mu_{TA}(1-\rho_{TA})x}$	$\frac{\rho_{TA}}{\mu_{TA}(1-\rho_{TA})}$
2. EDTCC No. 1 AK service consisting of: a) Message transmission time to EDTCC No. 1 SPE memory.	$1 - e^{-\mu_{TA}x}$	$\alpha_{TA} = \frac{1}{\mu_{TA}}$ a) α_{RTI}

DESCRIPTION	DISTRIBUTION FUNCTION	MEAN
<p>b) Wait for EDTCC nondisplay processing.</p> <p>c) Part of EDTCC No. 1 nondisplay processing (until AK generated).</p> <p>d) AK wait for completion of transmission of message being transmitted, if any, to RCC.</p> <p>e) Transmit AK to RCC No. 1 and RCC recognize it.</p> <p>α_{TA} = the sum of the means of 2a, b, c, d, e.</p> $= \alpha_{RTI} + \frac{\rho_{TN}}{\mu_{TN} (1-\rho_{TN})}$ $+ \alpha_{TNA} + \gamma_{TRA} + \alpha_{TRA}$		<p>b) $\frac{\rho_{TN}}{\mu_{TN} (1-\rho_{TN})}$</p> <p>c) α_{TNA}</p> <p>d) γ_{TRA} (Appen. I)</p> <p>e) α_{TRA}</p>
<p>3. Waiting time before RCC No. 1 keyboards.</p>	$P_{R_0} = \frac{\rho_k^r e^{-\rho_k}}{r! (r-\rho_k)}$ <p>where</p> $P_{R_0} = \frac{1}{\sum_{n=0}^{r-1} \frac{\rho_k^n}{n!} + \frac{\rho_k^r}{r! (r-\rho_k)}}$ <p>or, in simpler notation</p> $1 - Ae^{-Bx}$ <p>(see Saaty (11), p.116)</p>	<p>$\frac{A}{B}$</p>

DESCRIPTION	DISTRIBUTION FUNCTION	MEAN
4. RCC No. 1 keyboard service.	$1 - e^{-\mu_k x}$	$\alpha_k = \frac{1}{\mu_k}$
5. Waiting time before EDTCC No. 1 AK service.	$1 - \rho_{TA} e^{-\mu_{TA}(1-\rho_{TA})x}$	$\frac{\rho_{TA}}{\mu_{TA}(1-\rho_{TA})}$
6. RCC process and transmit to EDTCC SPE memory.	$1 - e^{-\mu_{RTI} x}$	$\alpha_{RTI} = \frac{1}{\mu_{RTI}}$
7. Wait for EDTCC No. 1 nondisplay processing.	$1 - \rho_{TN} e^{-\mu_{TN}(1-\rho_{TN})x}$	$\frac{\rho_{TN}}{\mu_{TN}(1-\rho_{TN})}$
8. EDTCC No. 1 nondisplay processing.	$1 - e^{-\mu_{TN} x}$	$\alpha_{TN} = \frac{1}{\mu_{TN}}$
9. Wait for EDTCC No. 1 output service to EDTCC No. 2 c channels where EDTCC No. 1 output service consists of:	$1 - \frac{P_{T_0} \rho_{TTO}^c e^{-\mu_{TTO}(c-\rho_{TTO})x}}{c! (c-\rho_{TTO})}$ <p>where</p> $P_{T_0} = \frac{1}{\sum_{n=0}^{c-1} \frac{\rho_{TTO}^n}{n!} + \frac{\rho_{TTO}^c}{c!(c-\rho_{TTO})}}$ <p>or, in simpler notation</p> $1 - D e^{-Fx}$	$\frac{D}{F}$

DESCRIPTION	DISTRIBUTION FUNCTION	MEAN
a) Message transmission time to EDTCC No. 2 SPE memory.		a) α_{TTI}
b) Wait for nondisplay processing.		b) $\frac{\rho_{TN}}{\mu_{TN} (1-\rho_{TN})}$
c) Part of EDTCC No. 2 nondisplay processing (until AK generated).		c) α_{TNA}
d) AK wait for output to EDTCC No. 1.		d) γ_{TRA} (App. I)
e) Transmit AK to EDTCC No. 1, and EDTCC No. 1 recognize it.		e) α_{TTA}
Total average EDTCC - EDTCC output service, the sum of the means of 9a, b, c, d, e		α_{TTO}
10. Transmit to EDTCC No. 2 SPE memory.	$1 - e^{-\mu_{TTI}x}$	$\alpha_{TTI} = \frac{1}{\mu_{TTI}}$
11. Wait for EDTCC No. 2 nondisplay processing.	$1 - \rho_{TN} e^{-\mu_{TN}(1-\rho_{TN})x}$	$\frac{\rho_{TN}}{\mu_{TN}(1-\rho_{TN})}$
12. EDTCC No. 2 nondisplay processing.	$1 - e^{-\mu_{TN}x}$	α_{TN}
13. Wait for output to DPC drum, nondisplay batch.	$1 - \rho_{TC} e^{-\mu_{TC}(1-\rho_{TC})x}$	$\frac{\rho_{TC}}{\mu_{TC} (1-\rho_{TC})}$

DESCRIPTION	DISTRIBUTION FUNCTION	MEAN
20. DDC expose (black and white).	$H(x-\alpha_{DE})$	α_{DE}
21. DDC project.	$H(x-\alpha_{DP})$	α_{DP}

Let $\beta = \alpha_{CT} + \alpha_{TD} + \alpha_{TS} + \alpha_{DE} + \alpha_{DP}$, the sum of the constant service times above (17 through 21).

4. LAPLACE-STIELTJES TRANSFORMS OF THE VARIOUS DISTRIBUTION FUNCTIONS

The following is a list of the LaPlace-Stieltjes transforms of the distribution functions to be summed. If it should turn out that the error bound in using the normal approximation is too high, it will be possible to take the product of these transforms to get the LaPlace-Stieltjes transform of the distribution function of the sum. The numbers refer to the list in Section 3.

1. $1 - \frac{\rho_{TA} s}{s + \rho_{TA} (1 - \rho_{TA})}$

7. $1 - \frac{\rho_{TN} s}{s + \mu_{TN} (1 - \rho_{TN})}$

2. $\frac{\mu_{TA}}{s + \mu_{TA}}$

8. $\frac{\mu_{TN}}{s + \mu_{TN}}$

3. $1 - \frac{As}{s+B}$

9. $1 - \frac{Ds}{s+F}$

4. $\frac{\mu_k}{s + \mu_k}$

10. $\frac{\mu_{TTI}}{s + \mu_{TTI}}$

5. Same as 1.

11. Same as 7.

6. $\frac{\mu_{TN}}{s + \mu_{RTI}}$

12. Same as 8.

<p>13. $1 - \frac{\rho_{TC}}{s + \mu_{TC}(1 - \rho_{TC})}$</p> <p>14. $\frac{\mu_{TC}}{s + \mu_{TC}}$</p> <p>15. $\frac{\mu_{BC}}{s + \mu_{BC}}, \frac{\mu_{BP}}{s + \mu_{BP}}$</p> <p>16. $\frac{1}{\alpha s} - \frac{e^{-\alpha s}}{\alpha s}$</p>	<p>17. $e^{-\alpha_{CT} s}$</p> <p>18. $e^{-\alpha_{TD} s}$</p> <p>19. $e^{-\alpha_{TS} s}$</p> <p>20. $e^{-\alpha_{DE} s}$</p> <p>21. $e^{-\alpha_{DP} s}$</p>	<p>} sum of these</p> <p>} $\alpha's = \beta$</p>
--	--	--

5. SUMMARY AND CONCLUSIONS

This paper has aimed to derive, under simple assumptions, a distribution function for the time in the system of the data in a message entering at a RCC and ending in a wall display; that is, the probability that this time is less than or equal to t is given by the function derived, equation (8) of Appendix II. This equation is given in parametric form, and the actual computation of this probability, based on traffic rates and equipment operating (service) times, will appear in a subsequent document.

Of course, without actual numbers it is hard to make judgments, but a crucial part of the system appears to be the operation of the display subsystem. (See reference 10.) A blocking effect, which reduces the system capability, can take place in the display equipment if the displays are permitted to arrive in some random fashion. This blocking effect can be eliminated entirely by sequentially ordering the outputs to the wall-display equipment, and this ordering can take place either in the DPC or in the EDTCC. (See reference 12.) However, it seems more efficient to do it in the DPC since it can then be transmitted with the most up-to-date information.

March 15, 1963

31

TM-1042/104/00

Also, from a preliminary review (10) it seems that the display traffic may be too much for the equipment and that some method should be devised to reduce traffic. A tentative suggestion is to set some minimum time between specific display updates, depending on the importance of the particular display and the ability of an observer to note rapid changes in a display. For example, a particular display will not be updated more often than once every two minutes. This limitation on displays should be made to limit traffic so that infinite queues cannot build up.

Another recommendation that would reduce the time in the system would be to have the RCC line stores capable of storing a message from any keyboard, not only their own, and to have 32 line stores, the maximum number, rather than the same number as there are keyboards. This would reduce the possibility of a keyboard being locked, which now occurs when there is a message in its line store. Thus, an operator could continue to put a message in the keyboard, although the previous one wasn't acknowledged. With the present system, the operator must wait for an acknowledge message to unlock the keyboard.

APPENDIX I

AVERAGE WAIT OF AK MESSAGE IN EDTCC OUTPUT QUEUE TO RCC

The AK message receives priority over all other messages (except for alert message) in the EDTCC's output to the RCC, except that it does not interrupt a transmission in progress, nor does it wait for an AK for a previous message to be received from the RCC before being transmitted. The EDTCC output can be in one of three possible states when an AK is to be transmitted.

- 1) Transmitting a data message.
- 2) Awaiting an AK.
- 3) Neither - call this idle.

If, for the purposes of determining the average wait of the AK for transmission, we consider a queue to the RCC with an arrival rate of λ_{TRD} (for data messages) and a double service consisting of 1) and 2) above, with mean service times of α_{TRD} and α_{RTA} respectively, then the total average service time for this queue is the sum denoted by α_{TRDA} . The traffic intensity is

$$\rho_{TRDA} = \lambda_{TRD} \alpha_{TRDA}.$$

This is a two-stage queue, and a message must go through both stages before another message can enter service. We are interested in the average wait of an AK message, γ_{TRA} .

When an AK arrives at the output from the EDTCC to the RCC, the probability of being in state 1) or 2) is ρ_{TRDA} , since this is the probability of a

regular message having to wait at all. This probability comes from this queue-waiting-time distribution:

$$P [\text{Waiting time} \leq x] = 1 - \rho_{\text{TRDA}} e^{-\mu_{\text{TRDA}} (1 - \rho_{\text{TRDA}}) x}$$

$$\begin{aligned} P [\text{Server is busy}] &= 1 - P [\text{no waiting}] = 1 - P [\text{waiting time} \leq 0] = \\ &= 1 - [1 - \rho_{\text{TRDA}}] = \rho_{\text{TRDA}}. \end{aligned}$$

Since an AK will have to wait if and only if the EDTCC output is in state 1, we are interested in this probability. The time spent in each service state is proportional to the average time of each service. The probability of being in state 1) is $\frac{\alpha_{\text{TRD}}}{\alpha_{\text{TRDA}}} \rho_{\text{TRDA}}$,

and the probability of being in state 2) is $\frac{\alpha_{\text{RTA}}}{\alpha_{\text{TRDA}}} \rho_{\text{TRDA}}$.

The probability of being in state 3) is, $1 - \rho_{\text{TRDA}}$.

We can now compute γ_{TRA} .

$$\gamma_{\text{TRA}} = \alpha_{\text{TRD}} \left(\frac{\alpha_{\text{TRD}}}{\alpha_{\text{TRDA}}} \rho_{\text{TRDA}} \right) + 0 [\text{Prob. of being in state 2}] + \quad \text{I-1}$$

$$0 [\text{Prob. of being in state 3}].$$

This follows from

$$E[X] = \sum_{k=1}^n E[X|Y=k] p[Y=k].$$

The first term of equation I-1 is based on the assumption that the transmission time of a message is exponentially distributed. In this case, the

March 15, 1963

34

TM-1042/104/00

unexpended transmission time has the same distribution as the transmission time itself.

Or, if this exponential assumption is not made, then certainly the average AK wait for transmission cannot exceed γ_{TRA} since α_{TRD} is the average time for a complete transmission.

APPENDIX II

DERIVATION OF THE DISTRIBUTION FUNCTION AND ERROR ESTIMATE

We assume that Y , U and C are independent random variables. In the system the times appear in the order stated above: first Y , which takes the system through to the DPC output; then U , the time to the next periodic update of a wall display; then C , the constant time spent going from the DPC to projection on a wall screen. Since the time between updates is assumed to be fixed by a schedule, and not dependent on the time spent in the system to that point, we assume that the time between updates, U , is statistically independent of Y . By the same reasoning we assume that C , the constant time it is assumed to take in going from the DPC to projection onto a wall, is statistically independent of Y and U . Thus, we are able to arrive at the distribution of $S = Y + U + C$ by the convolution of the three distribution functions.

We are interested in the distribution function of the sum $S = Y + U + C$ where

Y = the sum of the exponential service times and the waiting times.

U = the uniformly distributed random variable.

C = the constant service time.

This S represents the total time spent in the system, and we will obtain its distribution function, $F(x) = P[S \leq x]$ = the probability that the time in the system is $\leq x$.

For the distribution of Y , we conjecture from the Central Limit Theorem that the distribution of the standardized variable $N = \frac{Y-m}{\alpha}$ can be approximated

by the normal distribution denoted by $\Phi(x)$, with mean 0 and variance 1. Here $m = E[Y]$ and $\sigma^2 = E[(Y-m)^2]$.

To find the distribution of S, we first put all the variables in the same scale, and determine the distribution of

$$S_{\sigma} = N + \frac{U}{\sigma} + \frac{C}{\sigma}$$

The distribution functions are

$$P[N \leq x] = F_N(x) = \Phi(x) \text{ and} \quad (\text{II} - 1)$$

$$P[U \leq x] = F_U(x) = \begin{cases} 0 & x < 0 \\ \frac{x}{\alpha} & 0 \leq x \leq \alpha \\ 1 & x > \alpha, \end{cases} \quad (\text{II} - 2)$$

or $F_U(x) = \frac{x}{\alpha} H(x) - \frac{(x-\alpha)}{\alpha} H(x-\alpha);$

$$P[C \leq x] = F_C(x) = \begin{cases} 0 & x < \beta \\ 1 & x \geq \beta \end{cases} \quad (\text{II} - 3)$$

or $F_C(x) = H(x-\beta).$

The distribution of $\frac{U}{\sigma}$ is given by

$$F_{\frac{U}{\sigma}}(x) = P\left[\frac{U}{\sigma} < x\right] = P[U \leq \sigma x] = F_U(\sigma x) = \frac{\sigma x}{\alpha} H(\sigma x) - \frac{(\sigma x - \alpha)}{\alpha} H(\sigma x - \alpha)$$

or

$$F_{\frac{U}{\sigma}}(x) = \begin{cases} 0 & \text{for } \sigma x < 0 \text{ or } x < 0 \\ \frac{\sigma x}{\alpha} & \text{for } 0 \leq \sigma x \leq \alpha \quad \text{or } 0 \leq x \leq \frac{\alpha}{\sigma} \\ 1 & \text{for } \sigma x - \alpha > 0 \quad \text{or } x > \frac{\alpha}{\sigma}. \end{cases} \quad (\text{II} - 4)$$

Similarly, the distribution of $\frac{C}{\sigma}$ is given by

$$F_{\frac{C}{\sigma}}(x) = F_C(\sigma x) = H(\sigma x - \beta) \quad (\text{II} - 5)$$

or

$$F_{\frac{C}{\sigma}}(x) = \begin{cases} 0 & \text{for } x < 0 \\ 1 & \text{for } x \geq \frac{\beta}{\sigma} \end{cases}$$

To find the distribution of S_{σ} , we take the convolution of the distribution functions,

$$F_{S_{\sigma}} = F_N * \frac{F_U}{\sigma} * \frac{F_C}{\sigma}.$$

The convolution of F_N and $\frac{F_U}{\sigma}$ is

$$\begin{aligned} F_N + \frac{U}{\sigma}(x) &= \int_{-\infty}^{\infty} F_N(x-t) dF_{\frac{U}{\sigma}}(t) \\ &= \frac{\sigma}{\alpha} \int_0^{\frac{\alpha}{\sigma}} \phi(x-t) dt. \end{aligned}$$

An integration by parts on the last integral yields

$$F_N + \frac{U}{\sigma}(x) = \frac{\sigma}{\alpha} \left[t\phi(x-t) \Big|_0^{\frac{\alpha}{\sigma}} + \int_0^{\frac{\alpha}{\sigma}} t\phi(x-t) dt \right].$$

By the substitution, $z = x-t$,

$$\begin{aligned}
 F_{N + \frac{U}{\sigma}}(x) &= \frac{\sigma}{\alpha} \left[\frac{\alpha}{\sigma} \phi \left(x - \frac{\alpha}{\sigma} \right) - \int_x^{x - \frac{\alpha}{\sigma}} \phi(z) dz \right] \quad (\text{II} - 6) \\
 &= \phi \left(x - \frac{\alpha}{\sigma} \right) + \frac{\sigma}{\alpha} \left[x \left\{ \phi(x) - \phi \left(x - \frac{\alpha}{\sigma} \right) \right\} - \phi \left(x - \frac{\alpha}{\sigma} \right) + \phi(x) \right].
 \end{aligned}$$

The last two terms come from the interesting relation,

$$\int_{-\infty}^x z \phi(z) dz = -\phi(x).$$

The convolution of the right-hand side of equation (II - 6) with $F_{\frac{C}{\sigma}}(x)$ (the distribution function of the constant, that is, the sure event $C = \beta$) results in a translation,

$$\begin{aligned}
 F_{S_{\sigma}}(x) &= \int_{-\infty}^{\infty} F_{N + \frac{U}{\sigma}}(x-t) dF_{\frac{C}{\sigma}}(t) = \int_{-\infty}^{\infty} F_{N + \frac{U}{\sigma}}(x-t) \delta \left(t - \frac{\beta}{\sigma} \right) dt = \\
 &F_{N + \frac{U}{\sigma}} \left(x - \frac{\beta}{\sigma} \right).
 \end{aligned}$$

Therefore, by substitution in equation (II-6),

(II - 7)

$$F_{S_{\sigma}}(x) = \phi \left(x - \frac{\beta + \alpha}{\sigma} \right) + \frac{\sigma}{\alpha} \left[\left(x - \frac{\beta}{\sigma} \right) \left\{ \phi \left(x - \frac{\beta}{\sigma} \right) - \phi \left(x - \frac{\beta + \alpha}{\sigma} \right) \right\} - \phi \left(x - \frac{\beta + \alpha}{\sigma} \right) + \phi \left(x - \frac{\beta}{\sigma} \right) \right].$$

Thus,

$$\begin{aligned}
 F_S(x) &= P[S \leq x] = P[Y + U + C \leq x] = P[Y - m + U + C \leq x - m] = \\
 &= P\left[\frac{Y - m}{\sigma} + \frac{U}{\sigma} + \frac{C}{\sigma} \leq \frac{x - m}{\sigma}\right] = P\left[S_{\sigma} \leq \frac{x - m}{\sigma}\right] = F_{S_{\sigma}}\left(\frac{x - m}{\sigma}\right) \\
 F_S(x) &= \Phi\left(\frac{x - m - \beta - \alpha}{\sigma}\right) + \frac{\sigma}{\alpha} \int_{\frac{x - m - \beta}{\sigma}}^{\frac{x - m - \beta - \alpha}{\sigma}} \left[\Phi\left(\frac{x - m - \beta}{\sigma}\right) - \Phi\left(\frac{x - m - \beta - \alpha}{\sigma}\right)\right] - \\
 &\quad \varphi\left(\frac{x - m - \beta - \alpha}{\sigma}\right) + \varphi\left(\frac{x - m - \beta}{\sigma}\right) \Big\}. \tag{II-8}
 \end{aligned}$$

This is the distribution function we are seeking, and yields the probability that the time in the system is less than or equal to x .

An upper bound for the error, in using the normal distribution to approximate the sum of n independent random variables first derived by Liapounoff, is given by Uspensky (13, p. 296). Improved estimates are given by Berry (1) and by Esseen (4), but there is an error in Berry's computation (see Hsu, 7).

$$\begin{aligned}
 |F_N(x) - \Phi(x)| &\leq C \text{ (some function of certain moments) =} \\
 &C(n) \text{ for all } x \text{ (uniformly).}
 \end{aligned}$$

Therefore,

$$\left|F_N\left(\frac{x - m}{\sigma}\right) - \Phi\left(\frac{x - m}{\sigma}\right)\right| \leq C(n).$$

Since,

$$\begin{aligned}
 F_Y(x) &= P[Y \leq x] = P\left[\frac{Y - m}{\sigma} \leq \frac{x - m}{\sigma}\right] = F_N\left(\frac{x - m}{\sigma}\right), \text{ then} \\
 |F_Y(x) - \Phi\left(\frac{x - m}{\sigma}\right)| &\leq C(n);
 \end{aligned}$$

that is, the error in approximating the distribution function of Y by $\Phi\left(\frac{x-m}{\sigma}\right)$, which we have used, is bounded by this same quantity, $C(n)$.

Also, we have used $N + U$ to approximate $Y + U$, but the error is the same as for using N alone to approximate Y alone, since

$F_Y(x) = \Phi\left(\frac{x-m}{\sigma}\right) + \epsilon(x)$ where ϵ represents the error in the approximation and

$$|F_Y(x) - \Phi\left(\frac{x-m}{\sigma}\right)| = |\epsilon(x)| \leq C(n)$$

$$F_Y(x) * F_U(x) = \left[\Phi\left(\frac{x-m}{\sigma}\right) + \epsilon(x) \right] * F_U(x) = \Phi\left(\frac{x-m}{\sigma}\right) * F_U(x) +$$

$+ \epsilon(x) * F_U(x)$, by linearity of the convolution.

$$|F_Y(x) * F_U(x) - \Phi\left(\frac{x-m}{\sigma}\right) * F_U(x)| = |\epsilon(x) * F_U(x)|$$

$$= \left| \int_{-\infty}^{\infty} \epsilon(x-t) dF_U(t) \right|$$

$$\leq C(n) \int_{-\infty}^{\infty} dF_U(t) = C(n).$$

Thus, the error remains unchanged in the convolution.

The result given by Esseen is the following:

Let X_1, X_2, \dots, X_n be independent random variables. For each i ($i=1, 2, \dots, n$)

let $\mu_2(X_i)$ denote the second absolute central moment of X_i ,

$\mu_3(X_i)$ denote the third absolute central moment of X_i ,

$$\sigma_i = + \sqrt{\mu_2(X_i)},$$

and suppose that $\mu_2(X_i) > 0$ for at least one i .

$$E[X_i] = \alpha_i$$

The sum, $Y = X_1 + X_2 + \dots + X_n$, has mean value

$$M = \alpha_1 + \alpha_2 + \dots + \alpha_n$$

and standard deviation,

$$\sigma = (\sigma_1^2 + \sigma_2^2 + \dots + \sigma_n^2)^{\frac{1}{2}}.$$

Let

$F_N(x)$ be the distribution function of $\frac{Y-m}{\sigma}$,

$$B_{3n} = \frac{1}{n} \sum_{i=1}^n \mu_3(X_i)$$

$$B_{2n} = \frac{1}{n} \sum_{i=1}^n \mu_2(X_i);$$

then

$$|F_N(x) - \Phi(x)| \leq \frac{B_{3n}}{B_{2n}^{3/2}} \frac{1}{\sqrt{n}} 7.5 .$$

The Liapounoff result, given by Uspensky, (13) is,

$$|F_N(x) - \Phi(x)| < \frac{8}{5} W_{n,1} [(\log \frac{1}{3} W_{n,1})^{\frac{1}{2}} + 1.1] + W_{n,1}^2 \log \frac{1}{3} W_{n,1} + \frac{5}{3} W_{n,1}^{2/3} e^{-1/5 W_{n,1} - 2/3}.$$

where we shall suppose n so large that

$$W_{n,1} = \frac{B_{3n}}{B_{2n}^{3/2}} < \frac{1}{20}.$$

The Liapounoff estimate depends on a condition on $W_{n,1}$ (Esseen's does not) which of course depends on the parameter values.

If the condition is just barely met, that is if

$$W_{n,1} = \frac{1}{21},$$

the error is less than .11.

Under the same condition, $W_{n,1} = \frac{1}{21}$,

the Esseen estimate yields, for $n = 16$ (we are adding 17 random variables):

$$|F_n - \Phi| \leq \frac{7.5}{4} \cdot \frac{1}{21} = .09.$$

Of course, these results depend on the value of $W_{n,1}$ which remains to be computed when parameter values are known or estimated.

For a discussion of error bounds see the chapter by R. Fortet, in reference (8).

APPENDIX III

MOMENTS

A. The Moments of the Distributions

To make plausible the use of the Central Limit Theorem, we compute the moments of the distributions we are dealing with and show that they meet the condition on $W_{n, \delta}$ of the Liapounoff Theorem, stated in section III. The condition is repeated here:

$$\lim_{n \rightarrow \infty} W_{n, \delta} = \frac{\sum_{i=1}^n \mu_{2+\delta}^{(i)}}{B_n^{1+\frac{\delta}{2}}} = 0, \quad \delta > 0.$$

B. The LaPlace-Stieltjes Transform

We use the LaPlace-Stieltjes transform to compute the second and fourth moments of the distributions, i.e., $\delta = 2$, and show they meet the condition. The LaPlace-Stieltjes transform of $F(t)$ is $\chi(s)$, is defined as follows:

$$\chi(s) = \int_{-\infty}^{\infty} e^{-st} dF(t) = E(e^{-st}).$$

Then, if the moments exist

$$\chi'(s) = -\int_{-\infty}^{\infty} t e^{-st} dF(t), \quad \chi'(0) = -m_1,$$

$$\chi''(s) = \int_{-\infty}^{\infty} t^2 e^{-st} dF(t), \quad \chi''(0) = m_2,$$

and continuing in the same fashion, $\chi'''(0) = -m_3$,
 $\chi''''(0) = m_4$.

If $\chi(s)$ is analytic in a neighborhood of the origin,
 then

$$\chi(s) = \chi(0) + \chi'(0)s + \frac{\chi''(0)}{2!} s^2 + \dots, \quad |s| < r.$$

Therefore,

$$\chi(s) = \chi(0) - m_1 s + \frac{m_2}{2!} s^2 - \frac{m_3}{3!} s^3 + \frac{m_4}{4!} s^4 - + \dots, \quad |s| > r.$$

Thus, from the power series expansion of the transform, we can get the moments of the distribution.

However, we are interested in the central moments. But since we have positive random variables, it can be seen that the central moments are less than the absolute moments since

$$\mu_k = \int_0^{\infty} (t - m_1)^k dF(t) < \int_0^{\infty} t^k dF(t) = m_k, \text{ for } t, m_1 > 0.$$

Therefore, if the condition holds for the fourth moments in the numerator it will hold for the fourth central moments.

The distributions being summed are of the following types:

<u>Distribution (F(t))</u>	<u>LaPlace-Stieltjes Transform</u>
a) exponential, $1 - e^{-dt}$	$\frac{d}{s+d}$
b) waiting time, $1 - \alpha e^{-bt}$	$1 - \frac{\alpha s}{s+b}$

The power series expansions and moments are

$$a) \quad \frac{d}{d+s} = 1 - \frac{1}{d} s + \frac{1}{d^2} s^2 - \frac{1}{d^3} s^3 + \frac{1}{d^4} s^4 - + \dots, |s| < d$$

$$m_1 = \frac{1}{d}$$

$$m_3 = \frac{6}{d^3}$$

$$m_2 = \frac{2}{d^2}$$

$$m_4 = \frac{24}{d^4} .$$

$$b) \quad 1 - \frac{\alpha s}{b+s} = 1 - \frac{\alpha}{b} s + \frac{\alpha}{b^2} s^2 - \frac{\alpha}{b^3} s^3 + \frac{\alpha}{b^4} s^4 - + \dots, |s| < b$$

$$m_1 = \frac{\alpha}{b}$$

$$m_3 = \frac{6\alpha}{b^3}$$

$$m_2 = \frac{2\alpha}{b^2}$$

$$m_4 = \frac{24\alpha}{b^4} .$$

The variance (second central moment) is given by

$$m_2 - m_1^2, \text{ and for the various distributions, is given by,}$$

$$a) \quad \frac{1}{d^2}$$

$$b) \quad \frac{\alpha(2-\alpha)}{b^2} .$$

Since the normal distribution was used to approximate a sum of types a) and b), it remains to check condition (1) for these types. The condition will obviously hold for these types.

Since the fourth moments are bounded, let M represent an upper bound for the fourth moments, $m_4^{(i)}$, of the distributions, and since the variances are greater than zero, let $m > 0$ represent a lower bound for the variances. Then for $\delta = 2$,

$$\frac{\sum_{i=1}^n \mu_4^{(i)}}{\left(\sum_{i=1}^n \mu_2^{(i)}\right)^2} \leq \frac{\sum_{i=1}^n m_4^{(i)}}{(nm)^2} \leq \frac{nM}{n^2 m^2} = \frac{M}{nm^2}$$

which goes to 0 as $n \rightarrow \infty$.

APPENDIX IV

UNEXPENDED SERVICE TIME FOR EXPONENTIAL SERVICE

Let the random variable X , the service time of a channel, have an exponential distribution function

$$F(x) = 1 - e^{-\mu x}$$

Let

$f_0(x) = 1 - F(x)$, the probability that a service lasts longer than x .

$f_a(x)$ = the probability that a service which lasted for a , will continue for more than x .

Then

$$f_0(a+x) = f_0(a) f_a(x).$$

Thus,

$$e^{-\mu(a+x)} = e^{-\mu a} f_a(x),$$

from which it follows that

$$f_a(x) = e^{-\mu x} = f_0(x).$$

This means that for the exponential distribution, the distribution of the unexpended service time is the same as the service-time distribution and does not depend on how long the service has already lasted.

GLOSSARY

A. TERMS AND EQUIPMENT

- AK Acknowledge message.
- DDC Data Display Central. The display equipment.
- DPC Data Processing Central. The military computer in this system.
- EDTCC Electronic Data Transmission Control Central. A switching and routing center for system messages.
- EWO Emergency War Order. Under this condition, a method of computer operation is prescribed, which the model in this paper is meant to represent.
- RCC Remote Communications Complex. The input keyboards and associated transmission equipment at an air base.
- SPE Stored Program Element. The core storage in the EDTCC.
- SRCC Same equipment as RCC except that the RCC is duplexed.
- TCC Sometimes used instead of EDTCC. Both have the same meaning.
- TSA Digital data transfer system (Subscriber A). A remote keyboard for an RCC.

B. SYMBOLS USED

- λ Arrival rate, usually Poisson.
- α Mean service time, usually exponential.
- μ $1/\alpha$, service rate.
- ρ $\frac{\lambda\alpha}{r}$, traffic intensity where r is number of channels.
- γ Average waiting time.

SYMBOLS USED (cont'd)

λ_R Total arrival rate at RCC, of messages to be transmitted to EDTCC No. 1, Poisson parameter.

α_{TA} Average EDTCC No. 1 AK service time; this is a sum of:

$$\alpha_{RTI} + \frac{\rho_{TN}}{\mu_{TN} (1 - \rho_{TN})} + \alpha_{TNA} + \gamma_{TRA} + \alpha_{TRA}$$

μ_{TA} $1/\alpha_{TA}$ exponential parameter for EDTCC AK service.

ρ_{TA} $\lambda_R \alpha_{TA} = \frac{\lambda_R}{\mu_{TA}}$, traffic intensity, single channel,

Poisson-Exponential queue.

α_k Average RCC keyboard service time.

μ_k $1/\alpha_k$, exponential parameter for RCC keyboard service.

r Number of RCC keyboards.

ρ_k $\lambda_R \alpha_k = \frac{\lambda_R}{\mu_k}$, traffic intensity.

λ_{TN} Arrival rate of nondisplay messages to EDTCC.

α_{TN} Average EDTCC nondisplay processing time.

μ_{TN} $1/\alpha_{TN}$, exponential parameter for EDTCC nondisplay processing.

ρ_{TN} $\lambda_{TND} \alpha_{TND} = \frac{\lambda_{TND}}{\mu_{TND}}$, traffic intensity for EDTCC nondisplay processing.

α_{TNA} Average EDTCC nondisplay-processing time until AK is generated.

SYMBOLS USED (Cont'd)

- μ_{TN} $1/\alpha_{TN}$, exponential parameter for EDTCC nondisplay processing.
- ρ_{TN} $\lambda_{TND} \alpha_{TND} = \frac{\lambda_{TND}}{\mu_{TND}}$, traffic intensity for EDTCC nondisplay processing.
- α_{TNA} Average EDTCC nondisplay-processing time until AK is generated.
- α_{RTI} Average time to transmit information messages from RCC to EDTCC.
- α_{TRA} Average time for transmission of AK from EDTCC to RCC.
- γ_{TRA} Average wait of an AK message from EDTCC to RCC (derived in Appendix I).
- λ_{TTO} Data message traffic rate from EDTCC No. 1 to EDTCC No. 2.
- α_{TTO} Average EDTCC to EDTCC output service; this is the sum of:
- $$\alpha_{TTI} + \frac{\rho_{TN}}{\mu_{TN} (1-\rho_{TN})} + \alpha_{TNA} + \gamma_{TRA} + \alpha_{TTA}$$
- c Number of channels between EDTCC No. 1 and No. 2.
- ρ_{TTO} $\lambda_{TTO} \alpha_{TTO}$.
- α_{TTA} Average acknowledge message transmission time from EDTCC No. 2 to EDTCC No. 1 and recognized by EDTCC No. 1.
- α_{TTI} Average information-message-transmission time from EDTCC No. 1 to EDTCC No. 2 SPE memory.
- λ_{TC} Arrival rate of message from EDTCC No. 2 to DPC.
- α_{TC} Average transmission time from EDTCC to DPC.
- μ_{TC} $1/\alpha_{TC}$
- ρ_{TC} $\lambda_{TC} \alpha_{TC}$.

SYMBOLS USED (Cont'd)

- α_{BC} Average nondisplay-batch collection time (equals average processing time for an entire nondisplay batch).
- α_{BP} Average processing time for type of message considered (may equal α_{BC} if displays are entered in output table after entire batch is processed).
- α Time between periodic updates of a display - constant.
- α_{CT} Time to transmit display from DPC to EDTCC No. 2 - constant.
- α_{TD} EDTCC display-processing time - constant.
- α_{TS} Time to transmit display to DDC - constant.
- α_{DE} Time to expose display (black and white) - constant.
- α_{DP} Time to project display - constant.
- $\beta = \alpha_{CT} + \alpha_{TD} + \alpha_{TS} + \alpha_{DE} + \alpha_{DP}$, the sum of the constant service times.
- m The sum of the average waiting times and exponential service times in the system.

C. KEY TO SUBSCRIPTS

Equipment

T	EDTCC
R	RCC
C	Computer, DPC
S	DDC

March 15, 1963

52

TM-1042/104/00

KEY TO SUBSCRIPTS (cont'd)

Messages

I	Information
A	Acknowledge message
D	Display processing in EDTCC
N	Nondisplay processing in EDTCC
O	Output service
E	DDC expose
P	DDC process

REFERENCES

1. Berry, A. C. The Accuracy of the Gaussian Approximation to the Sum of Independent Variables. Transactions of the American Mathematical Society, 49, 1941, pp. 122-136.
2. Borotto, A., Kadas, S., Rota, P., and Steindler, K. Message Distribution Study--Phase III: First Hour 10C-EWO 465L System Traffic. SDC document FN-LO-445. February 1, 1961. SECRET.
3. Burke, P. J. The Output of a Queueing System. Operations Research, 4, 1956, pp. 699-704.
4. Esseen, C. G. --Fourier Analysis of Distribution Functions. Acta Mathematica, 77, 1945, pp. 1-125.
5. Feller, W. An Introduction to Probability Theory and Its Applications, Volume I. New York: Wiley and Sons, 1950.
6. Gang, M. I. and Rudie, D. D. EDTCC System Performance Analyses and Evaluation. SDC document FN-LO-553, May 9, 1961. SECRET.
7. Hsu, P. L. The Approximation Distributions of the Mean and Variance of a Sample of Independent Variables. Annals of Mathematical Statistics, 16, 1945, pp. 1-29.
8. Kaplansky, I., Hall, M., Hewitt, E., and Fortet, R. Some Aspects of Analysis and Probability. New York: Wiley and Sons, 1958.
9. Reich, E. Waiting Times When Queues are in Tandam. Annals of Mathematical Statistics, 28, 1957, pp. 768-773.
10. Rosenberger, J., Theobald, C., and Walker, D. Analyses and Evaluation of the Data Presentation Subsystem. SDC document FN-LO-599. July 25, 1961, SECRET.
11. Saaty, T. L. Elements of Queueing Theory. New York: McGraw-Hill, 1961.
12. Theobald, C. E. Maximum Mean Traffic Rate for a Cascaded Multichannel Queueing Model. SDC document FN-LO-694. April 19, 1962.
13. Uspensky, J. V. Introduction to Mathematical Probability. New York: McGraw-Hill, 1937.
14. Wishart, D. M. G. Queueing Systems in Which the Discipline is "Last-come First-served." Operations Research, 8, 1960, pp. 591-599.

UNCLASSIFIED

System Development Corporation,
Santa Monica, California
A SIMPLIFIED QUEUEING MODEL
FOR THE 465L SYSTEM.
Scientific rept., TM-1042/104/00,
by S. Gorenstein. 15 March 1963,
53p., 14 refs.

Unclassified report

DESCRIPTORS: Strategic Air Command.

Reports that this study makes a
preliminary investigation of the

UNCLASSIFIED

time it takes, under EWO (Emergency
War Order) conditions, for
information to be displayed from
the time of entry into the 465L
(Strategic Air Command Control
System) system.

UNCLASSIFIED

UNCLASSIFIED