



भारतीय मानक ब्यूरो BUREAU OF INDIAN STANDARDS

MANAK BHAVAN, 9 BAHADUR SHAH ZAFAR MARG, NEW DELHI 110002
Phone: + 91 11 23230131, 23233375, 23239402 Extn 4402; Fax: + 91 11 23235529

व्यापक परिचालन मसौदा

हमारा संदर्भ : सीईडी 46/टी-24
तकनीकी समिति: राष्ट्रीय भवन निर्माण संहिता विषय समिति, सीईडी 46

07 दिसम्बर 2012

प्राप्तकर्ता :

- 1 सिविल इंजीनियरी विभाग परिषद् के रूचि रखने वाले सदस्य
- 2 राष्ट्रीय भवन निर्माण संहिता विषय समिति, सीईडी 46 व सस्टेनेबिलिटी के लिए पैनल, सीईडी 46.पी 19 के सभी सदस्य
- 3 रूचि रखने वाले अन्य निकाय ।

महोदय/महोदया,

निम्नलिखित मसौदा संलग्न है:

प्रलेख संख्या	शीर्षक
सीईडी 46(7830)	भारत की राष्ट्रीय भवन निर्माण संहिता 2005 (SP 7:2005) की संशोधन संख्या 1 (द्वारा नया भाग 11 सततता को पहुँच, को सम्मिलित करना) का मसौदा

कृपया इस मसौदे का अवलोकन करें और अपनी सम्मतियाँ यह बताते हुए भेजें कि यदि यह मसौदा भारत की राष्ट्रीय भवन निर्माण संहिता के भाग के रूप में प्रकाशित हो तो इस पर अमल करने में आपके व्यवसाय अथवा कारोबार में क्या कठिनाइयाँ आ सकती हैं ।

सम्मतियाँ भेजने की अंतिम तिथि : **15 मार्च 2013** ।

यदि कोई सम्मति हो तो कृपया अधोहस्ताक्षरी को उपरिलिखित पते पर संलग्न फॉर्मट में भेजें । हो सके तो कृपया अपनी सम्मतियाँ ई-मेल द्वारा sanjaypant@bis.org.in पर भेजें ।

यदि कोई सम्मति प्राप्त नहीं होती है अथवा सम्मति में केवल भाषा सम्बन्धी त्रुटि हुई तो उपरोक्त प्रलेखों को यथावत अंतिम रूप दे दिया जाएगा । यदि सम्मति तकनीकी प्रकृति की हुई तो विषय समिति के अध्यक्ष के परामर्श से अथवा उनकी इच्छा पर आगे की कार्यवाही के लिए विषय समिति को भेजे जाने के बाद प्रलेख को अंतिम रूप दे दिया जाएगा ।

यह प्रलेख भारतीय मानक ब्यूरो की वेबसाइट www.bis.org.in पर भी उपलब्ध है ।

धन्यवाद ।

भवदीय,

संलग्न: उपरिलिखित

(डी0 के0 अग्रवाल)

वैज्ञानिक 'एफ' एवं प्रमुख (सिविल इंजीनियरी)

फोन/फैक्स : 011-23235529



भारतीय मानक ब्यूरो BUREAU OF INDIAN STANDARDS

MANAK BHAVAN, 9 BAHADUR SHAH ZAFAR MARG, NEW DELHI 110002
Phone: + 91 11 23230131, 23233375, 23239402 Extn 4402; Fax: + 91 11 23235529

**DRAFT IN WIDE
CIRCULATION**

DOCUMENT DESPATCH ADVICE

Reference	Date
CED 46/T-24	07 December 2012

TECHNICAL COMMITTEE:

NATIONAL BUILDING CODE SECTIONAL COMMITTEE, CED 46

ADDRESSED TO:

1. All Members of Civil Engineering Division Council, CEDC
2. All Members of National Building Code Sectional Committee, CED 46 and Panel for Sustainability, CED 46:P19
3. All others interests.

Dear Sir/Madam,

Please find enclosed the following draft:

Doc. No.	Title
CED 46(7830)	Draft Amendment No. 1 to National Building Code of India 2005 (SP 7:2005) (to incorporate a new Part 11 Approach to Sustainability)

Kindly examine the draft and forward your views stating any difficulties which you are likely to experience in your business or profession if this is finally adopted as Part of the National Building Code of India.

Last Date for comments: **15 March 2013** .

Comments if any, may please be made in the format as attached, and mailed to the undersigned at the above address. You are requested to send your comments preferably through e-mail to sanjaypant@bis.org.in.

In case no comments are received or comments received are of editorial nature, you may kindly permit us to presume your approval for the above document as finalized. However, in case of comments of technical nature are received then it may be finalized either in consultation with the Chairman, Sectional Committee or referred to the Sectional Committee for further necessary action if so desired by the Chairman, Sectional Committee.

This document is also hosted on BIS website www.bis.org.in.

Thanking you,

Yours faithfully,

(D.K. Agrawal)
Sc 'F' and Head (Civil Engg)
Telefax: 011 23235529

Encl: as above

FORMAT FOR SENDING COMMENTS ON THE DOCUMENT

[Please use A4 size sheet of paper only and type within fields indicated. Comments on each clause/sub-clause/ table/figure, etc, be stated on a fresh row. Information/comments should include reasons for comments, technical references and suggestions for modified wordings of the clause. **Comments through e-mail to sanjaypant@bis.org.in shall be appreciated.**]

Doc. No.: CED 46(7830)WC **BIS Letter Ref:** CED 46/T-24 **Dated:** 07 December 2012

Title: Preliminary Draft Amendment No. 1 to National Building Code of India 2005 (SP 7:2005) (to incorporate a new Part 11 Approach to Sustainability)

Name of the Commentator/ Organization: _____

Clause/ Para/ Table/ Figure No. commented	Comments/Modified Wordings	Justification of Proposed Change

BUREAU OF INDIAN STANDARDS

DRAFT FOR COMMENTS ONLY

(Not to be reproduced without the permission of BIS or used as an Indian Standard/as an amendment to National Building Code of India)

Draft **AMENDMENT NO. 1**

TO

**NATIONAL BUILDING CODE OF INDIA 2005
(SP 7:2005)**

Add a new part, **Part 11 Approach to Sustainability**, as enclosed.

Draft

NATIONAL BUILDING CODE OF INDIA

PART 11 APPROACH TO SUSTAINABILITY

BUREAU OF INDIAN STANDARDS

IMPORTANT EXPLANTORY NOTE FOR USERS OF CODE

In this part, where reference is made to 'good practice' in relation to design, constructional procedures or other related information, and where reference is made to 'accepted standard' in relation to material specification, testing, or other related information, the Indian Standards listed at the end of this section may be used as a guide to the interpretation.

At the time of publication, the editions indicated in the above Indian Standards were valid. All standards are subject to revision and parties to agreements based on this section are encouraged to investigate the possibility of applying the most recent editions of the standards.

In the list of standards given at the end of this part, the number appearing in the first column indicates the number of the reference in this part. For example:

- a) good practice [11(3)] refers to the Indian Standard given at serial number (3) of the above list given at the end of this Part 11, that is IS 456:2000 Code of practice for plain and reinforced concrete (*fourth revision*)
- b) accepted standard [11(7)] refers to the Indian Standard given at serial number (7) of the above list given at the end of this Part 11, that is IS 9142:1979 Specification for artificial light-weight aggregates for concrete masonry units.
- c) accepted standard [11(10)] refers to the Indian Standard given at serial number (10) of the above list given at the end of this Part 11, that is IS 1725:1982 Specification for soil-based blocks used in general building construction
- d) good practices [11(11)] refers to the Indian Standards given at serial number (11) of the above list given at the end of this Part 11, that is IS 401:2001 Code of practice for preservation of timber (*fourth revision*) and IS 1141:1993 Code of practice for seasoning of timber (*second revision*)

C O N T E N T S

FOREWORD

1 SCOPE

2 TERMINOLOGY

2.1 to 2.38

3 APPROACH TO SUSTAINABILITY

3.1 The Need for Sustainable Development

3.2 Elements of Sustainability

3.3 Life Cycle Sustenance

3.4 Technology Options

3.5 Energy Efficient Design and Processes

3.6 Reduced Embodied and Operational Energy

3.7 Integrated Water Management

3.8 Operation and Maintenance of Services

3.9 Monitoring Compliances

3.10 Corporate Governance

3.11 Disaster Preparedness

4 APPLICABILITY OF THIS PART

5 IMPLEMENTATION OF THIS PART

6 SITING, FORM AND DESIGN

6.1 General

6.2 Site Design and Development

7 EXTERNAL DEVELOPMENT AND LANDSCAPE

7.1 Landscape Design

7.2 Rainwater Harvesting

7.3 Water Elements and Irrigation Practices

7.4 External Access Design

7.5 External Lighting Design

8 ENVELOPE OPTIMIZATION

8.1 Building Envelope

8.2 Envelope Optimization Methods

8.3 Renewable Energy Integration in Envelope

9 MATERIALS

- 9.1 General
- 9.2 Materials and Recommended Sustainable Alternatives
- 9.3 Construction Phase Material Storage and Handling
- 9.4 Construction Waste Management

10 WATER AND WASTE MANAGEMENT

- 10.1 General
- 10.2 Planning and Design of Water Management System
- 10.3 Planning and Design of Waste Water System
- 10.4 Water and Waste Management During Construction
- 10.5 Process Water Requirement and Effluent Treatment
- 10.6 Planning and Design of Solid Waste Management System
- 10.7 Integrated Approach to Water Supply, Water Waste and Solid Waste Management

11 BUILDING SERVICES OPTIMIZATION

- 11.1 General
- 11.2 Concept Development
- 11.3 Natural and Mechanical Ventilation Strategies
- 11.4 Passive Heating Techniques
- 11.5 Passive Cooling Techniques
- 11.6 Pre-Cooling of Ventilation Air
- 11.7 Low Energy Mechanical Cooling Techniques
- 11.8 HVAC System
- 11.9 Electrical System
- 11.10 Lighting
- 11.11 Lifts and Escalators
- 11.12 Good Installation Practices
- 11.13 Commissioning and Handing Over
- 11.14 Operation and Maintenance
- 11.15 Ongoing Performance
- 11.16 Renewable Energy

12 CONSTRUCTIONAL PRACTICES

- 12.1 Pre-Construction Pre-requisites
- 12.2 Planning for Construction
- 12.3 Preparation of Construction Management Plan
- 12.4 Planning, Monitoring and Control of Environmental Descriptors
- 12.5 Work Execution Procedures
- 12.6 Effective Use of Water
- 12.7 Construction Waste Management
- 12.8 Post-construction Closeout
- 12.9 Heritage Buildings and New Construction
- 12.10 Alternate Use, De-construction, Dismantling and Demolition
- 12.11 Disaster Risk Mitigation during Construction

13 COMMISSIONING, OPERATION, MAINTENANCE AND BUILDING PERFORMANCE TRACKING

- 13.1 General
- 13.2 Commissioning and Handover
- 13.3 Operation and Maintenance
- 13.4 Building Performance Tracking (Measurement and Verification)
- 13.5 Operator Skills and Training
- 13.6 Control-System Maintenance

ANNEX A DESIGN STRATEGIES AS PER CLIMATE ZONES FOR VARIOUS SEASONS

ANNEX B PRESCRIPTIVE METHOD FOR ENVELOPE OPTIMIZATION

ANNEX C TRADE-OFF METHOD FOR ENVELOPE OPTIMIZATION

ANNEX D WHOLE BUILDING ANALYSIS METHOD FOR ENVELOPE OPTIMIZATION

LIST OF STANDARDS

BUREAU OF INDIAN STANDARDS**WIDE CIRCULATION DRAFT**

(FOR COMMENTS ONLY)

(Not to be reproduced without the permission of BIS or used as an Indian Standard/as a Part of National Building Code of India)

Draft NATIONAL BUILDING CODE OF INDIA:
PART 11 APPROACH TO SUSTAINABILITY
(Draft SP 7: 2005 - Part 11)

ICS: 0.120; 91.040.01

National Building Code
Sectional Committee, CED 46

Last Date for Comments
15 March 2013

FOREWORD

Ancient civilizations used to build edifices using locally available materials, with great skill, and in harmony with nature. Basham in 'The Wonder that was India' describes how palaces in Mauryan dynasty in second century B.C., were exquisitely built from carved wood of local deodars. In later years the monasteries, temples and *dharmashalas* were built with locally available stones; these have withstood the ravages of time. Edwin Arnold in 'The Light of Asia' describes *Vishramvan*, the palace built with local marble and alabaster for prince Siddharth. The epic Mahabharata describes palace built by Vishwakarma. *Kashi Vishwanath* Temple in Varanasi, was built more than a thousand years ago. Many other ancient monuments in all parts of India are classic examples of sustainable buildings.

The *Taj Mahal*, built more than four hundred years ago, can accommodate 10 000 people with no suffocation, as the stone *jalīs* in the facade induce air movement and enable natural ventilation. The fort in *Mandu* has elaborate rain water harvesting techniques. *Havelis* in northern India were invariably built around a central courtyard, which brought day light in all nooks and corners, but the heat was kept out. Many forts and *havelis* have elaborate provision for evaporative cooling, using *khas*-screens and rain water stored at higher plateaus. Sustainable building has been the way of life in India.

Less than a hundred years ago, industrial revolution came to India and changed many of these traditional sustainable practices in Indian buildings. The insatiable thirst for progress and comfort-at-any-cost, altered the equation with nature for ever. Concrete, steel, glass and later plastics became the dominant construction materials, beyond stone and wood of yesteryears. Power supply, artificial lighting, water supply and disposal, and thermal environmental control within built environment, were desired and obtained.

The new civilizations grew along the river banks, always regarding rivers as sacred. With the industrial revolution, untreated water, effluents from chemical industries and organic waste were discharged into rivers and water bodies, destroying our precious sources of water for domestic use. In addition, the unsustainable development of buildings and industries have led to huge construction waste and solid waste during their operation, which today have become a major problem.

Modern buildings in India consume about 25 to 30 percent of total energy, and up to 30 percent of fresh potable water, and generate approximately 40 percent of total waste. India is now entering the phase of rapid urbanization. Various studies indicate that by 2050, the built foot print of India may become four times the current mass, which may pose a major challenge in preserving our fragile environment. Although the present energy consumption per capita in India is a fraction of that of most developed nations, but with its projected growth, unless enough measures are taken, it may lead to acceleration of environment degradation, contributing to increased carbon footprint leading to global warming and climate change.

Sustainable buildings have demonstrated reduction in energy and water consumption to less than half of the present consumption in conventional buildings, and complete elimination of the construction and operational waste through recycling. The Indian way of life is *aparigraha* (minimum possession), conservation (minimum consumption) and recycling (minimum waste). These three attributes are the guiding principles for sustainable buildings as well. With these attributes and its rich heritage, India can make a substantial contribution in this field and eventually lead the world on the path of sustainability.

Developed nations' approach to sustainability generally concentrates on energy conservation through high technology innovations, and use of products, materials and designs with lower embodied energy. Their green ratings are based on intent, which implies expert inputs and simulation. Indian construction industry will do better using our traditional wisdom and practices, building in harmony with nature through regional common knowledge, consuming as little as necessary, applying low cost technology innovations, using recycled materials, and recognizing performance (not intent) through easily measurable parameters wherever feasible.

Aiming towards such objectives, the National Building Code Sectional Committee, CED 46 reviewed the present contents of the Code. The Sectional Committee observed that, in the Code, due considerations have been given to these important dimensions in building planning, design and construction and during operation through provisions of effective utilization of natural light and ventilation; increased use of renewable energy, material selection including recyclability and reusability aspects; use of low gestation plantations and agriculture and industrial wastes; design approach; proper management practices; efficient electrical and other building services and plumbing services; energy conservation; rain water harvesting; etc. All these have been duly interwoven throughout the Code addressing both the embodied energy and the operational energy involved, as also showing sensitivity towards the concerns such as ozone depletion, global warming, etc. The Committee, however, felt that in keeping with the present needs as well as likely future scenario,

it may be appropriate to completely review all such aspects and give them a special and separate identity in the form of Part 11 of the Code covering sustainability approach to buildings.

This Part 11 'Approach to Sustainability' provides a comprehensive set of requirements, intended to reduce the negative impact of buildings on the natural environment. It can be readily used by the owners, developers/builders, architects, engineers, building services engineers and other building professionals as well as by manufacturers of building materials apart from the Authorities concerning land and building development, government and private construction agencies and academic and research institutions. The intent of this Part is to highlight sustainability measures including those referred to in different Parts/Sections of the Code as may be required as well as to define comprehensive sustainability standards for the building construction and related built environment.

The approach to sustainability is founded on principles consistent with this Code, to adequately protect public health, safety and welfare and to provide requirements that do not unnecessarily increase construction cost nor restrict the use of new materials, products or methods of construction. The benefits of incorporating measures listed in this Part 11 are not only environment friendly, but also result in much better health and productivity of occupants, at minimal additional initial cost over the cost of conventional buildings, while substantially reducing the life cycle cost. This minimal additional cost is offset during a few years usage of the buildings, and vast advantage in cost is accrued during the life cycle of the building.

The measures of sustainable buildings described in this Part of the Code set performance thresholds and incorporate features that allow Authority to customize requirements according to local geographical conditions, environmental priorities and agenda. These are not specific to any rating system and are not intended to provide a single metric indication of overall building performance. The flexibility of these provisions allows the practitioners to easily exercise their engineering judgment in holistically and objectively applying the underlying principles of sustainability to a development or building facility, considering its functionality and required comfort level.

The information contained in this Part has been brought in coherence with the provisions contained in other parts of the Code, as also the concerned Indian Standards on various areas. In preparation of this Part, efforts have been made to take into cognizance the various latest applicable practices followed in the country and abroad, relevant to sustainability in buildings. This has been done by taking into consideration the publications of the American Society for Heating, Refrigeration, Air-conditioning Engineers; Bureau of Energy Efficiency, India; Indian Green Building Council; Indian Society for Heating, Refrigeration, Air-conditioning Engineers; International Organisation for Standardisation; and The Energy and Resource Institute.

WIDE CIRCULATION DRAFT

(FOR COMMENTS ONLY)

(Not to be reproduced without the permission of BIS or used as an Indian Standard/as a Part of National Building Code of India)

Draft **NATIONAL BUILDING CODE OF INDIA: PART 11 APPROACH TO SUSTAINABILITY (Draft SP 7: 2005 - Part 11)**

ICS: 0.120; 91.040.01

**National Building Code
Sectional Committee, CED 46**

Last Date for Comments
15 March 2013

1 SCOPE

1.1 This Part covers the parameters required to be considered for planning, design, construction, operation and maintenance of buildings and relating to land development from sustainability point of view.

1.2 This Part is a supplement to all other Parts/Sections of the Code and shall be read along with the same.

2 TERMINOLOGY

2.0 For the purpose of this Part, the following definitions shall apply.

2.1 Authority Having Jurisdiction – The authority which has been created by a statute and which, for the purpose of the Code/Part, may authorize a committee or an official or an agency to act on its behalf; herein after called the authority.

2.2 Biodiversity – The variability among living organisms from all sources including terrestrial, marine and other aquatic ecosystems and the ecological complexes of which they are a part; this includes diversity within spaces, between species, and of ecosystems.

2.3 Building Environment – The surrounding in which a building operates, including air, water, land, natural resources, flora, fauna, human beings and their inter-relations.

2.4 Building Performance – Ability of a building to fulfil required functions under intended use conditions or behaviour when in use.

2.5 Built Environment – The collection of man-made or induced physical objects located in a particular area or region.

NOTE – When treated as a whole, the built environment typically is taken to include buildings, external works (landscape areas), infrastructure and other construction works within the area under the consideration.

2.6 Disaster – It is a catastrophe, mishap, calamity or grave occurrence in any area, arising from natural or man-made causes, or by accident or negligence which results in substantial loss of life, or human suffering or damage to, and destruction of, property or damage to or degradation of environment, and is of such a nature of magnitude as to be beyond the coping capacity of the community of the affected area.

2.7 Ecosystem – Community of biological organisms and their physical environment, functioning together as an interdependent unit within a defined area.

NOTE – For the purpose of this definition, humans, animals, plants, and micro-organisms are individually all considered biological organisms.

2.8 Embodied Energy – The sum total of energy that is used to extract, process, package, transport and install the material in the building.

NOTE – Embodied energy data is often collected using input and output analysis.

2.9 Emissivity (E) – It is the ratio of the rate of heat emitted by a surface as compared to that of an absolutely black surface under similar conditions. It varies with the temperature of the emitting surface.

2.10 Environmental Impact – Any change to the environment, whether adverse or beneficial, wholly or partially, resulting from environmental aspects of a building.

2.11 Green Roof System – An assembly that supports an area of planting/landscaping, built up on a waterproofed substrate at any level that is separated from the natural ground by a human made structure.

2.12 Heat Island Effect – A phenomenon in which urban air and surface temperature are higher than nearby rural areas due to the replacement of natural land cover with pavement, building, and other infrastructure.

2.13 Horizontal Sun Angle (HSA) – The horizontal angle between the normal of the window and the Sun azimuth angle at a given time (see Fig. 1).

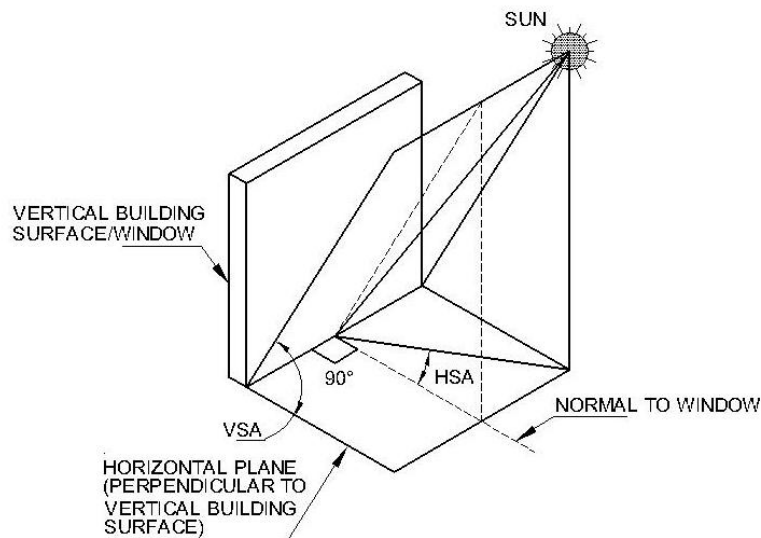

FIG. 1 HORIZONTAL AND VERTICAL SOLAR ANGLE FORMULATION

2.14 Indoor Air Quality (IAQ) – The nature of air in the area where one works or lives that affects the health and well being of building occupants.

2.15 Indoor Environment Quality (IEQ) – The condition or state of the indoor environment.

2.16 Life Cycle Assessment (LCA) – A method of evaluating a product by reviewing the ecological impact over the life of the period.

NOTE – At each stage, the product and its components are evaluated based upon the materials and energy consumed, and the pollution and waste produced. Life stages include extraction of raw materials, processing and fabrication, transportation, installation, use and maintenance, and reuse/recycling/disposal.

2.17 Non-Renewable Source – Resource that exists in a fixed amount that cannot be replenished on a human time scale.

NOTE – Non-renewable resources have the potential for renewal only by the geological, physical and chemical processes taking place over hundreds of millions of years. Non-renewable resources exist in various places in the earth's crust. Examples include iron ore, coal, and oil.

2.18 Renewable Resource – A resource that is grown naturally, can be replenished, or cleansed.

NOTE – Sustainable use of renewable resource implies that the rate of growth, replenishment, or cleansing takes place at a rate equal to or greater than the current rate of

depletion of that resource. Examples include trees in forest, grasses in grassland, and fertile soil.

2.19 Reuse – Using a material, product or component of the waste stream in its original form more than once.

2.20 Recycling – Process to turn the materials, that would otherwise become waste, into valuable resources.

2.21 Skylight Roof Ratio (SRR) – The ratio of the total skylight area of the roof, measured to the outside of the frame, to the gross exterior roof.

2.22 Solar Heat Gain Coefficient (SHGC) – The SHGC is the fraction of incident solar radiation admitted through a window, both directly transmitted, and absorbed and subsequently released inward through conduction, convection and radiation (see Fig. 2).

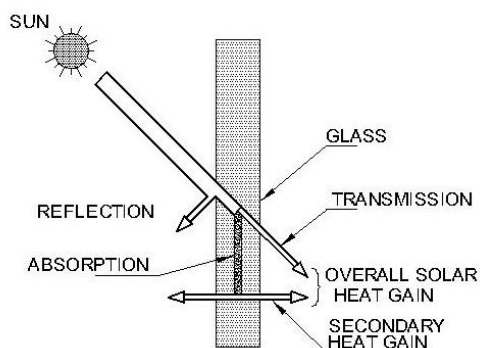

FIG 2 MECHANISM OF SOLAR HEAT GAIN

2.23 Solar reflectance index (SRI) – A measure of material's ability to reject solar heat, as shown by a small temperature rise.

NOTE – SRI of standard black surface (having reflectance of 0.05 and emittance of 0.9) and a standard white surface (of reflectance 0.8 and emittance 0.9) are taken as 0 and 100 respectively.

2.24 Sustainability – The state in which components of ecosystem and their functions are maintained for the present and future generations.

NOTES

1. Sustainability is the goal of sustainable development and can result from the application of the concept of sustainable development.
2. In building construction, it relates to how attributes of activities, materials/products or services used in construction work, or use of construction works, contribute to the maintenance of ecosystem components and functions for future generations.
3. While the challenge of sustainability is global, the strategies for sustainability in building construction are local and differs in context and content from region to region.

4. 'Components of ecosystem' includes plants and animals, as well as humans and their physical environment. For humans, this includes a balancing of key elements of human needs namely the economic environmental, social and cultural conditions for societies' existence.

2.25 Sustainable Buildings – A building that provides the specified building performance requirements while minimizing disturbance to and improving the functioning of local, regional, and global ecosystem both during and after its construction and specified service life.

NOTE – A sustainable building optimizes efficiencies in resource management and operational performance; and, minimizes risks to human health safety and the environment.

2.26 Sustainable Development – Development that meets the need of the present without compromising the ability of future generations to meet their own.

2.27 Thermal Absorptivity – A factor indicating the relative amount of radiation absorbed by a surface as compared to an absorbing black body under the same conditions. Its value is dependent upon the temperature of the source and of the receiving surface.

2.28 Thermal Capacity – The amount of heat necessary to raise the temperature of a given mass by 1 °C. Numerically, the thermal capacity per unit area of surface is the sum of the products of the mass per unit area of each individual material in the roof, wall or floor surface multiplied by its individual specific heat.

2.29 Thermal Conductance (C) – The thermal transmission of a single layer structure per unit area divided by the temperature difference between the hot and cold faces. It is expressed in $W/m^2 K$ (Watt per square meter-degree Kelvin).

NOTE – Thermal conductance is a measure of the thermal transmission per unit area through the total thickness of the structure under consideration. Thermal conductivity on the other hand refers to unit thickness of material. Further, this term applies only to a single layer of material and not to a composite insulation or to a structure made up of several layers of materials or medium.

2.30 Thermal Conductivity (K) – The quantity of heat in the steady state conditions flowing in unit time through a unit area of a slab of uniform material thickness of infinite extent and of unit thickness, when unit difference of temperature is established between its faces unit is W/mK (Watt per meter-degree Kelvin).

NOTE – Thermal conductivity is a characteristic property of a material and its value may vary with a number of factors, including density, porosity, moisture content, fibre diameter, pore size, type of gas in the material, mean temperature and outside temperature range. The conductivity value varies from 0.03 W/mk for insulators to 400 W/mk for metals. Materials with lower conductivity are preferred, as they are better insulators and reduce the external heat gains from the envelope.

2.31 Thermal Reflectivity – The ratio of the reflected heat to that of the total heat incident on a surface at a certain mean temperature range.

2.32 Thermal Resistance (R) – Thermal resistance is reciprocal of thermal conductance. For a structure having plane parallel faces, thermal resistance is equal to thickness (L) of the structure divided by thermal conductivity (K).

$$R = \frac{L}{K}$$

NOTE – The usefulness of the quantity is that when heat passes in succession through two or more components of the building units, the resistance may be added together to get the total resistance of the structure.

2.33 Thermal Resistivity ($1/k$) – The reciprocal of thermal conductivity. It is expressed in mk/W .

2.34 Thermal Transmittance (U) – Thermal transmission through unit area of the given building unit divided by the temperature difference between the air or other fluid on either side of the building unit in steady state conditions. It is also called as U -value. Its unit is $\text{W/m}^2\text{k}$.

NOTE – Thermal transmittance differs from thermal conductance in so far as temperatures are measured on the two surfaces of a building unit in the latter case and in the surrounding air (or other fluid) of the material on the two sides, in the former case. Thermal conductance is a characteristic of the building unit whereas thermal transmittance depends on conductance and surface coefficients of the building unit under the conditions of use.

2.35 Vertical Solar Angle (VSA) – The angle that a plane containing the bottom two points of the window and the centre of the Sun makes with the ground when measured normal to the shaded surface (see Fig. 1).

2.36 Visual Light Transmittance (VLT) – The ratio of total transmitted light to total incident light.

2.37 Volatile Organic Compound (VOC) – The carbon compounds (excluding carbon monoxide, carbon dioxide, carbonic acid, metallic carbides or carbonates, and ammonium carbonate) which participate in atmospheric photochemical reactions. The compounds vaporize at normal room temperatures.

2.38 Waste – Substances or objects which the holder intends or is required to dispose off.

3 APPROACH TO SUSTAINABILITY

3.1 The Need for Sustainable Development

Building construction, occupancy and additions/alterations including preventive and curative maintenance are always energy centric. Large amount of elementary form of energy in the form of water, natural materials, air, etc are consumed for the purpose. While, these elements and their use are inter-dependent and there is need for integrated approach of considering them all together in general design development

and construction practice, the approach towards utilizing them is independent of each other.

With increasing urbanization and rapid rise in people's economic level and consumption pattern in many parts of the country, there is an increasing trend to consume more natural resources per capita. This is evident from the aspirational lifestyles and resulting in changing tastes and expenditure patterns of individuals and societies. This is equally witnessed from modern construction trends and changing sky lines of cities. This is constantly putting tremendous pressure on fragile ecosystem by over exploitation of natural resources adversely affecting biodiversity of our planet. Realizing this fact, there are efforts for a changing approach towards nature initially from 'humanization of nature' to 'naturization of human' and more recently towards sustainable development. The concept is to ensure that every living being on earth will have equal opportunity to utilize the natural and man made resource for survival and to develop for mutual benefits for all time to come. The inclusive aspect of development will come into sharp focus while deciding on choices.

To achieve this, it is important to accept major challenge in controlling and judiciously using natural resources to shrink ecological foot print, famously known as carbon foot print, a measure to understand our consumption patterns. The way to achieve this is by holistically planning our growth needs, one of which is construction and combining them with need based economy, but at the same time without compromising on functionality and essential comforts.

The basic components of building facility, their inter-correlation, tradeoffs and effect on surrounding micro-climatic conditions have to be understood, to achieve the harmony between buildings and ecological surroundings. It is necessary to assess the association of various factors involved, rationalizing the impacts of construction on neighbourhoods or building micro-climatic conditions for sustainability of built environment.

3.2 Elements of Sustainability

The generalized design process towards sustainability should comprise the following steps:

- a) Set the design parameters to be implemented above benchmarking standards given in this Code.
- b) Make the basic performance requirements and set standards, applicable/ selectively adaptable to the climatic zone and geological conditions in which the construction is proposed.
- c) Have deep understanding of requirements of performance and human comfort, considering building type and use, quality of building and plumbing services desired, etc in buildings.
- d) Question the need, identify their optimum levels in long term scenario, and take the design provisions to that level only.
- e) Ensure what is sustainable today, remains that way in decades to come, and ensure the required performance levels of systems designed.

- f) Ensure that sustainability is not only in parts, but also a holistic effort.
- g) Make efforts to maximize the use of traditional wisdom in design, wherever applicable, as it represents the knowledge about the long-term behaviour of materials and technology and their strengths as well as weaknesses.
- h) While having an open approach, assess new materials and technologies for their long-term impact in the context of the country and its development priorities, before accepting them for use.
- i) Take decision making processes to measurable levels wherever feasible, in order to make judicious choices.
- j) Take the savings' benchmark targets closer to the minimum consumption standards; undertake value engineering exercises for deciding among the options.

This process emphasizes the requirement of bottom up approach which invariably considers microclimatic conditions around.

NOTE – The 'bottom up approach' concentrates more on how little is consumed; pursue our understanding of sustainability; uses low technology innovations, materials and practices; recognizes performance to be more important than intent; and necessitates the use of common knowledge and common sense in design decisions. On the contrast, the 'top down approach' concentrates more on how much energy is saved; accepts the understanding of sustainability may not be developed indigenously more readily; uses high technology innovations, materials and practices; is driven by green brand and accompanying recognitions based on intent; and necessitates expert inputs and simulations.

The design process itself can play a significant role in creating built environment respecting all principles of sustainable development. This has to take into account the various climatic zones like hot-dry, warm-humid, composite, temperate and cold climates as well as sun path movements and annual wind directions.

This should also reflect the aspirational needs of barrier free environment by differently abled people including by people under various age groups. Functional requirements of buildings have to also measure up to the required comfort levels demanded for all types of user requirements.

3.3 Life Cycle Sustenance

The process flow from concept, design, construction, commissioning, operation and maintenance, and also decommissioning and disposal at the end of useful life of structure, should be planned and important steps chalked out for sustainable development. This should also take care of possible reuse/recycle of materials/components/structure or part thereof.

3.4 Technology Options

The consequential building envelope to create harmonious development with neighbourhood and building environments poses one of the biggest challenges in selection of building materials, technologies and practices. It may be a combination of natural and manmade materials with least embodied energy and also leading to use of fast renewable resources. The trade-off between choice of the materials and

technologies and their effect on environment has to be balanced. As a holistic approach, all efforts should be made towards:

- a) Encouraging and harnessing building materials out of agricultural, industrial and bio-wastes, which has an enormous scope.
- b) Encouraging indigenous environment-friendly and acceptable cost-effective technologies and practices in identifying and pursuing sustainable developments.
- c) Identifying and encouraging appropriate technologies for more research and development applications.
- d) Making building construction more indigenous, more adaptable to climatic zones of India and also executable to achieve the basic provisions for sustainable development.
- e) Encouraging use of traditional technologies and local vernacular design and construction practices, which have stood the test of time which may be blended with the modern technology applications.

3.5 Energy Efficient Design and Processes

All efforts need to be made towards optimum and efficient use of energy sources for life sustenance. The increasing thrust on using non-fossil fuel energy for all needs have to be given priority consideration. The tapping of renewable sources of energy for lighting, heating, cooling and ventilation needs, deserve special attention. For example, an improved day light factor will reduce the day lighting needs by means of supplementary lighting. India with over 95 percent of the clear design sky available, the design has to fully utilize the associated benefits. While deciding on the energy choices, life cycle cost analysis including tangible and intangible benefits should be made and not look at the onetime initial capital expenditure alone.

3.6 Reduced Embodied and Operational Energy

All designs, materials and technologies, construction practices should be selected and employed aimed at reducing the overall embodied and operational energy involved in construction and operation of the built facility.

3.7 Integrated Water Management

Considering an ever increasing demand for water, efforts are needed to substantially reduce water consumption in buildings. Integrated and sustainable water management focusing on least anthropogenic water discharge from human activities should be pursued. The use of water conserving fixtures, landscaping, rain water harvesting, aquifer recharging and waste-water recycling need to be given due consideration.

3.8 Operation and Maintenance of Services

This should involve use of efficient building and plumbing services components and fixtures tailor-made to meet sustainability objectives and creating sufficient

awareness among the users of building facility and its services, during the occupancy stage.

3.9 Monitoring Compliances

The measures adopted during design, construction and occupancy stages should be monitored against design norms as per this Code at periodic time interval to ensure sustainability.

3.10 Corporate Governance

The concerned top management concerned should ensure association of all concerned including the training needs, for implementing provision for sustainable development at all stages. The environmental impact assessment should be carried out and remedial measures based on the findings should be taken during the life cycle of the buildings.

3.11 Disaster Preparedness

3.11.1 General

Disaster preparedness as a part of approach to sustainability is in addition to the normal considerations of structural safety, health safety, fire safety and public safety taken into account for building planning, design and construction. The disasters may be natural disasters such as earthquake, floods, cyclone, tsunami, landslides and avalanches; and man-made disasters such as nuclear, chemical, and biological disasters, and terrorism.

Also man made or natural disasters can trigger combined form of disasters and any disaster can lead to series of disasters. The severity index is another important factor which will be governed by geomorphology and climatic zone wherein the construction is proposed. Refer *National Building Code of India: Part 6 Structural Design* for structural design of buildings against various loads, forces and effects using various material streams.

3.11.2 Approach

The approach to disaster mitigation and management should be holistic and integrated with emphasis on prevention, mitigation and preparedness rather than being relief centric. The approach should emphasize on preparedness through planning, protection, training and partnership measures.

These efforts are aimed to conserve developmental gains as also minimize losses to lives, livelihood and property with clear cut focus on protection of environment. The approach shall be towards integrating disaster management as a part of design development, construction practices and management, and operation and

maintenance. The required awareness should be achieved through displays, mock drills and training.

The disaster risk identification and mitigation should consist of identifying risks during construction, risks during occupancy stages/operations and preparing disaster preparedness plan. The occupancy type, density of occupancy and any specific/strategic aspects should be considered while working out disaster preparedness plan for the sustainable buildings for least damages or losses.

3.11.3 Disaster Risk Assessment and Mitigation.

The preparation of disaster preparedness plan should comprise the following steps:

- Step 1: Identify the geomorphology and climatic zone related disasters
- Step 2: Identify population and business related disasters.
- Step 3: Carry out hazard analysis including possible combining effects of multi-disasters. Also include the effect on micro-climatic and environment surroundings. Coastal zones which are also seismically severe, seismic zones of high intensity and landslide sensitive areas should receive special attention.
- Step 4: Identify the socio-political hazards which are part of man-made disasters.
- Step 5: Prepare a disaster risk reduction plan. Allocate sufficient budgetary provisions.
- Step 6 : The disaster resistant building construction and infrastructure development features shall form part of submittal to the Authority for statutory approvals.
- Step 7: Establish/nominate a responsible senior person/safety officer as controller for application and monitoring of disaster preparedness plan for whole construction site.
- Step 8: Carry out all constructions, installations and operations in line with the disaster resistant features for each of the vulnerabilities.
- Step 9: Prepare and have mock drills at regular intervals for creating awareness and response preparation.
- Step 10: Prepare operation manual for post-construction and operations.

The basic action plan should focus on capacity building, communication, co-ordination, role of information technology, role of every individual working at site and role of emergency response cell of local/state level authorities. The possible after-effects on micro-climatic conditions and mitigation plan should form integral part of disaster preparedness plan for least damage to human life loss and built environment.

4 APPLICABILITY OF THIS PART

4.1 Where a building is erected, this Part of the Code may be applied to such buildings being erected.

If the existing structures are to be renovated or added and/or altered then such parts of building may be applied under the provisions of this Part. However owner will have opportunity to get existing as well new parts of buildings equally evaluated under the provisions of this Code.

4.2 This Part of the Code may also be applied to the development projects.

5 IMPLEMENTATION OF THIS PART

5.1 Provisions for building planning, design including material selection and structural design, construction, operation and maintenance have been covered in *National Building Code of India: Part 0 to Part 10*. These also allow various options to be exercised, for example while various building materials have been listed therein along with their quality requirements for compliance, the choice may rest with the owner/ building professionals, say for walling or masonry units, the options could be: use of common burnt clay bricks, perforated clay bricks, hollow clay bricks, fly ash lime bricks, fly ash clay bricks, calcium silicate bricks, solid/hollow concrete blocks, light weight concrete blocks, autoclaved aerated concrete blocks, preformed foam concrete blocks or any other alternative specified. This Part 11 discusses such options from sustainability point of view for guiding in their appropriate selection. Similar explanation applies to other materials as also other aspects in planning, design, construction, operation and maintenance. However, once a choice of material, design methodology, construction technique/methodology, operation and maintenance related options, etc, is made, the provisions given in this Part for the same shall be complied with. This Part 11 also prescribes provisions to be necessarily complied with so as to help achieve the objective of sustainability.

This Part should, therefore, be implemented in light of the above while following the approach given in **3**. The Authority may require submission and verification of relevant documents while applying for building permit, to demonstrate compliance to the requirements of various provisions under this Part.

6 SITING, FORM AND DESIGN

6.1 General

Before initiating the formal design process, it is critical to evaluate all the passive design options to take advantage of local site and climatic conditions. Passive techniques are very cost effective, help a building integrate better with its immediate environment and most importantly do not create any negative impact on the environment unlike active systems that may cause various negative impacts including ozone depletion and global warming. The objective, therefore, is to encourage passive design strategies for every building as a means to reduce overall energy consumption before pursuing active and mechanical means in an effort to not

only save energy but also allow buildings and its operations to seamlessly integrate with its immediate environment while minimizing the overall negative impact on the environment.

The provisions under **6.2** cover the requirements for the development of building and building sites that encourages sustainable building practices including siting, form and design approach towards sustainable development. The purpose includes providing directions that establish objectives for siting and form of residential, mercantile, industrial or other building occupancy developments early in the design stage so as to address sustainability through design. These objectives include but are not limited to energy conservation, water conservation and reduced greenhouse gas emissions.

6.2 Site Design and Development

6.2.1 Site Assessment Prior to Design

The responsible design professional shall prepare an assessment of the onsite natural resources and pre-site conditions. The person shall:

- a) establish if there are any protection areas such as floodplains; forest department areas; water bodies such as sea, lakes, rivers, wetlands, tributaries and/or streams; public parks and recreation areas (unless otherwise used for the purpose of the park); and agricultural land (unless serving an agriculturally related purpose such as storage, processing, transport, etc) and demonstrate that no critical natural resource is impacted by the project and/or dredging operations;
- b) establish the degree to which the existing soil at site and hydrology has been disturbed prior to development and demonstrate various site erosion protection measures taken including measures to preserve top soil and existing vegetation, minimize soil disturbance; and
- c) identify and ensure removal of existing invasive vegetation on site and that no invasive vegetation is planted post completion.

A site assessment report for the building/development project shall be prepared.

6.2.2 Building Orientation and Shading

The development shall plan on locating, orienting and shading the building so that:

- a) there is a provision for external shading of the south façade during the peak summer season;
- b) there is a provision for vertical shading to prevent direct solar radiation and glare due to low altitude sun angles, specially on the eastern and western facades;
- c) the building is oriented with the long sides facing north and south whenever the site and location permit such orientation; and

- d) there is a protection for the building envelope against thermal losses, drafts and degradation by natural elements such as wind and materials such as dust, sand, snow, rainwater, hail, etc.

The responsible design professional shall carry out building orientation and shading studies and establish the optimal building orientation for the project and ensure appropriate shading design. Orient buildings and design shading devices to optimize use of solar energy. A report showing both the optimal orientation and the choice of the proposed orientation of the building together with the design approach for decision making shall be prepared.

6.2.3 Thermal Massing

The responsible design professional shall carry out building thermal massing studies to evaluate the impact on thermal mass on the energy performance of the building based on the local/equivalent weather data. A report showing both the optimal thermal massing and the choice of the proposed wall material of the building together with the design approach for decision making shall be prepared.

6.2.4 Reduced Building Footprint in Multi-Storeyed Building Designs

The requirements for open spaces (within a plot) as specified in **8** of *National Building Code of India: Part 3 Development Control Rules and General Building Requirements* shall be complied with. In any case, at least 30 percent of the open spaces shall be maintained as softscapes on ground.

6.2.5 Reduced Building Volume

For air conditioned buildings, efforts shall be made in design to reduce building volume by reducing floor to floor and floor to ceiling height without compromising from a daylighting, performance and utility point of view.

6.2.6 Building Form Development Plan

A report shall be submitted on the evolution of the form of the building based on scientific logic. The plan shall be in line with the decision making process of the project team and a narrative shall be prepared.

6.2.7 Natural Ventilation and Cooling

A report illustrating the evaluation of the various natural ventilation and cooling studies for the project, shall be prepared. In addition, for high-rise buildings, wind analysis shall be carried out to evaluate the impact on wind movement and natural air flow changes because of the new building proposed to be erected. Strategies may include application of cross-ventilation, and taking into account prevalent wind patterns, seasonality, stack effect and other principles. A narrative on how these aspects have been factored in the design shall be prepared.

6.2.8 Optimal Daylighting

A day lighting analysis study based on the proposed form of the building for the project shall be carried out and documented. It shall be demonstrated that at least 50 percent of the regularly occupied areas of the building achieve sufficient day lighting with a minimum day lighting factor of 2 percent. For details of day lighting harvesting methods and calculations, refer to **8.1.3.2**.

6.2.9 Define Building Service Life in Terms of Minimum Component Service Life

A building service life plan shall be prepared along with the design and construction documents. The plan shall clearly indicate the design service life and the minimum design service life shall be not less than 60 years for the structure itself and not less than 10 years for various components, equipment and systems within the building. However, if it is part of a larger community development plan approved by the Authority, a lower design service life not below 25 years shall be permitted for the building structure. All plan shall include dismantling, de-mounting and re-use plan.

6.2.10 Life Cycle Assessment (Optional)

The materials and assemblies may be selected based on their carbon footprint (GHG emission potentials) and/or a Life Cycle Assessment of the embodied energy of the product. For more details on LCA analysis of building materials, refer **9.1.4**.

7 EXTERNAL DEVELOPMENT AND LANDSCAPE

7.1 Landscape Design

The landscape planning and design shall be in accordance with *National Building Code of India: Part 10 Landscaping, Signs and Outdoor Display Structures: Section 1 Landscape Planning and Design*. In addition, the provisions given in **7.1.1** to **7.1.3** shall be followed.

7.1.1 Landscape Design

Proper landscaping helps in maintaining natural capacity of site for stormwater management, filtration, groundwater recharge and maintenance of soil structure thereby contributing to soil organic matter, and preventing erosion. It helps in moderating microclimate through evaporation, transpiration and the uptake and storage of carbon in trees and other vegetation.

7.1.1.1 Microclimatic conditions

Microclimatic conditions play an important role in landscape design and in working out irrigation requirements, as it accounts for the environmental conditions specific to the landscape, including temperature, wind and humidity. For example, a water body can increase the humidity and a wind funnel can increase the evapo-transpiration rate and hence the irrigation requirement. The microclimatic conditions may be taken into account in landscape irrigation calculations by applying a microclimate factor.

The average microclimate factor is 1.0 and this refers to conditions where the landscape evapo-transpiration rate is unaffected by buildings, pavements, reflective surfaces and slopes. Higher Microclimate factor conditions occur where evaporative potential is increased due to landscapes surrounded by heat-absorbing and reflective surfaces or are exposed to particularly windy conditions. Examples of high microclimate factor areas include parking lots, west sides of buildings, west and south sides of slopes, medians, and areas experiencing wind funnel effects. Areas with low microclimate factor include shaded areas and areas protected from wind. North sides of buildings, courtyards, areas under wide building overhangs and north sides of slopes.

7.1.1.2 Barrier free external landscape

The external landscape shall be barrier free to enable access in the permitted areas to all.

7.1.1.3 External noise reduction/mitigation practices

Need for reducing the noise at site shall be assessed. If so required, appropriate measures may be taken for noise abatement, such as quieter pavement or road surfacing, dense foliage, earth berms, barriers or screens, and scheduling maintenance activities when site users are not present. Walls, fences and vegetation may also be used to break, guide, deflect or filter the wind and thereby alter its effects. Noise may be reduced with use broad-leaved trees more than with the conifers and this further improves when foliage extends close to the ground. The best location for a noise barrier is either very close to the source or very close to the receiver while the worst position for attenuation is halfway between them. Provisions of *National Building Code of India: Part 8 Building Services: Section 4 Acoustics, Sound Insulation and Noise Control*, shall be followed.

7.1.1.4 Building shadow considerations on landscape

Vegetation provides climate moderating benefits as well as benefits to human health. Most vegetation require sunlight in varying degrees for their growth and maintenance. The Buildings by their design, shade certain parts of the external areas for some part of the day or other. External landscapes shall be designed taking the shading pattern of the buildings into consideration. For instance the north side external areas of the building tend to be shaded for large parts of the day, while the South side has access to sunlight for most times of the day, the choice of vegetation should be based on the availability of sunlight along different solar exposures and the requirement of various species of vegetation. Vegetation also has the potential to reduce the energy consumption of a building by providing shading and a cool microclimate. Vegetation and/or vegetated structures shall be kept in strategic locations around buildings to reduce energy consumption and costs associated with indoor climate control.

7.1.2 Hard Landscape Design

7.1.2.1 Pervious paving design

Pervious paving helps in holding rain water, reducing the rate of storm water flow, infiltrating storm water into the ground for reuse and also helps in filtering the rain water. Besides helping in storm water management, pervious paving helps in reducing the heat Island effect. For sustainable site planning, perviousness in the paved areas of the site may be maximized.

However, the rain water harvesting potential of pervious paving is subject to local geo-morphological formations and the use of the same should be assessed based on local conditions. For example, in coastal areas, where the water table may be high and the water absorptive capacity is low, pervious paving may not be as effective.

7.1.2.2 Heat island effect and parking design

The heat island effect raises the localized temperature, impacting local climate/microclimate. Plants and animals that are sensitive to large fluctuations in day time and night time temperatures may not thrive in areas affected by heat island. Heat islands also exacerbate air pollution as smog is produced faster at higher temperatures and as rising temperatures lead to increased cooling requirements, requiring energy and causing associated emissions.

Open parking areas consisting of concrete and asphalt absorb heat and contribute substantially to the heat island effect. Shading and/or use of light-coloured/high-albedo materials and/or open grid pavement for the site's non-roof impervious surfaces, including parking lots, walkways, plazas, etc shall be made to help in reducing the heat island effect.

7.1.2.3 Post-occupancy maintenance

A site maintenance plan shall be developed that outlines the long-term strategies and identifies short-term actions to achieve sustainable maintenance goals. The Plan should address issues such as plant maintenance, integrated pest management, soil management and fertilizer use, site safety and irrigation allotment and schedule.

7.1.3 Soft Landscape Design

7.1.3.1 Preserving top soil

Healthy soils allow rainwater to penetrate, preventing excess runoff, sedimentation, erosion, and flooding. Soils also help clean and store water, and recharge groundwater. By storing water and slowing the delivery of water to plants, healthy soils play a significant role in vegetation health. In areas of previously disturbed soils, soil function shall be restored to rebuild ability of soils to support healthy plants, biological communities, and water storage and infiltration. In existing soils, depending upon the requirement, the need of soil compaction, organic matter levels, and the balance of soil organisms shall be addressed. It shall be ensured that adequate soil volume is made available for proper plant growth. In order to protect soil horizons and maintain soil structure, existing hydrology, organic matter, and

nutrients stored in soils, the disturbance to healthy soil shall be limited. Typically, the first 200 mm soil depth is most conducive for plant growth, and is considered as top soil. Where healthy top soil is being disturbed due to construction activities like excavation, the top soil should be stripped and stacked on one side till further use. Refer 4 of *National Building Code of India: Part 10 Landscaping, Signs and Outdoor Display Structures: Section 1 Landscape Planning and Design*, for further details regarding protection of landscape during construction.

7.1.3.2 Ecological design/conserving bio-diversity

A diverse range of species, especially native plants can provide habitat for native fauna, including important pollinator species (for example, insects, birds and bats) that are necessary for plant reproduction, including cultivation of crops. Also, biodiversity in landscapes helps in retaining soil nutrients and is more resistant to attacks by pests. The following considerations shall be used:

- a) *Protection and use of existing vegetation* – Such sites shall be selected that do not include habitat for threatened or endangered species. Site may be designed to minimize disruption to existing habitats. Trees designated as important by concerned local, state or central authorities shall be preserved. Mature trees are significant community resources because of their cultural, aesthetic, or historic relevance and shall be preserved. Transplantation for mature trees within the site or to another site shall be explored, where vegetation clearing is necessary for construction.
- b) *Use of vegetation that promotes a regional identity and a sense of place* – Native plants which are endemic to the location and appropriate non-native plants adapted to site conditions, climate, and design which support biodiversity, reduced pesticide use and water conservation, shall be used. Only non-invasive plants that are nursery grown, legally harvested or salvaged for reuse from on or off-site shall be used.
- c) *Conservation of native endangered species* – Native vegetation that is endangered in the locality may be planted to conserve/enhance the gene pool of native vegetation and promote biodiversity.

7.1.3.3 Landscape design for controlling solar gain

Vegetation placed in strategic locations around buildings provides an opportunity to reduce energy consumption and costs associated with indoor climate control for cooling. Trees, shaded trellises, green roofs, green facades and green walls may be used individually or in conjunction with other measures to increase shading both on the ground and on the building surface. Deciduous trees allow access to the sun in winter and provide shade in summer. Vegetation provides significant opportunities in conserving building energy consumption, specially if the west, south-west, south-east and east facades of the building are shaded. For Buildings with natural ventilation, the vegetation species shall be carefully chosen such that they provide shade, but do not significantly block cool breezes or any convective air currents.

7.1.3.4 Vertical landscaping and roof gardens

Green walls or vertical landscaping along with a roof garden may be provided as it helps in conserving energy by providing shading, reduces heat island effect, helps (specially in dense urban areas) in maintaining a certain biomass critical for human health and also helps in reducing storm water flow rates through bio-retention.

7.1.3.5 Urban agricultural practices/social forestry

Growth of cities puts a significant pressure on natural resources resulting in drastic reduction of green open spaces, depletion of trees, heat island effects, and floods and other natural disasters, further aggravated by the effects of climate change. Proper attention may be given to the potentials of urban forestry and agriculture for contributing towards urban greening, heat reduction, storage of excess storm water and maintaining flood plains free from construction. Large scale developments that exceed 10 hectares should be encouraged to fulfil minimum 5 percent bio-capacity required to sustain themselves.

7.2 Rainwater Harvesting – Surface Runoff

7.2.1 Rainwater Harvesting

Rainwater harvesting refers to collection and storage of rain water and also other activities aimed at harvesting surface and ground water, prevention of losses through evaporation and seepage and all other hydrological studies and engineering interventions, aimed at conservation and efficient utilization of the limited water endowment of physiographic unit such as watershed. In general, rain water harvesting is the activity of direct collection of rain water. The rain water collected can be stored for direct use or can be recharged into the ground water. While enough measures should be taken voluntarily, the Authority should encourage and appropriately provide for ensuring rain water harvesting in outdoor built environment.

The system of collection of rainwater and its conservation for future needs has traditionally been practiced in the country, such as through *baoris*, step wells, lakes, tanks, roof top collection systems, etc to meet the domestic and irrigation demands. This also helps to arrest ground water decline and augment ground water table, beneficiate water quality in aquifers, conserve surface water runoff during monsoon, reduce soil erosion and inculcate a culture of water conservation.

Two broad approaches to rain water harvesting are:

- a) *Storing rain water for direct use* – Under this approach, for domestic and irrigation purposes, the rainwater is directly collected either in the natural or man-made structures such as *Nadi*, *Tanka*, *kund*, sand filter bed, pond, rooftop rain water collection structure, etc.

Roof rain water collection system augments the water demands by collecting rain water from the roof and diverting it to specially designed storage or recharge tanks, as per the requirement. On sloping roofs, evaporation losses

are small, so collection efficiency may be of the order of 85 percent. Rainwater may be collected from any kind of roof. Tiled or metal roofs are easier to use for the purpose and a smooth surface for the roof will help in water flow and collection.

To reduce contamination of rooftop rainwater, the necessary actions and precautions as given below shall be followed:

- 1) Avoid overhanging of trees above the roof to prevent leaves and bird droppings falling on the roof.
 - 2) Do not allow the first rainfall to enter the tank by diverting it away from tank; although human or animal coli forms are not involved, bird droppings or lizard faeces, and other air borne dirt are also to be washed away from the roof.
 - 3) Filter the water on entering the tank by suitable filter and also cleaning the filter and tank regularly.
 - 4) Seal tanks to keep out sunlight (to prevent algae growth), mosquitoes, lizards, birds, etc.
 - 5) Disinfect tanks once in a year with bleaching powder.
- b) *Recharging groundwater aquifers* – This approach involves use of various kinds of recharge structures, which not only arrest the water but also promote water percolation through soil strata to recharge the depleting aquifers. Structures like percolation tank, anicuts, gabion, etc facilitate the recharge of underground aquifers. However, meteorological and hydrological investigations along with geo-technical investigations shall be carried out before selecting the best suited method for ground water recharge. Direct injection of rainwater through deep bore wells should be avoided for quality control reasons.

For rainwater harvesting a reference to **5.5.12** of *National Building Code of India: Part 9 Plumbing Services: Section 1 Water Supply, Drainage and Sanitation* may be made. For further details, reference may also made to good practice [11(1)].

7.3 Water Elements and Irrigation Practices

7.3.1 Design and Post Occupancy Maintenance of Water Features

The site maintenance plan (see **7.1.2.3**) shall include appropriate maintenance activities for the water features taking care of the following considerations:

- a) Use of chemicals likely to harm aquatic life, such as chlorine and bromine shall be avoided.
- b) Maintenance activities to ensure that the water features do not create habitat for mosquitoes, shall be included.
- c) Water features shall be designed such that they match or mimic water in the natural environment; and water features that are incompatible with the local ecological context (*for example*, a lake in a desert) shall be avoided.
- d) Volumes of rainwater or water from other non-potable sources available on

site for use in water features shall be estimated, and water features shall be so designed that these are integrated with the site so as to utilize this water on site, and not require additional water from potable water sources.

- e) Non-potable water from sources such as rain water from rooftops, gray water, reclaimed water or storm-water basins shall be collected and used for non-potable applications.
- f) Design and maintain water features as natural ecosystems with water source(s), plants and aquatic organisms appropriate for local conditions.
- g) Water quality may be enhanced in created water features with biologically-based water treatment including with the use of certain beneficial bacteria, enzymes, mineral, and oxygen-based additives, specially during initial establishment.
- h) Natural swimming pools or other water features intended for human contact may require additional treatment methods such as ozonation or thermal treatment.

7.3.2 Water Conservation and Irrigation Practices

Selecting efficient irrigation systems, planting vegetation appropriate for site conditions and climate, and using captured rainwater or gray-water can reduce water waste and conserve sources of potable water. Typically, half of irrigation water may get wasted as a result of evaporation, wind, improper system design, and over-watering requiring the following considerations which may be followed:

- a) Low-water-demand vegetation (xeriscape) and high-efficiency equipment (for example, drip irrigation) and/or climate based controllers for irrigation systems should be used.
- b) If turf grasses are to be used, they should be selected, to be regionally appropriate and to minimize post-establishment requirements for irrigation. The turf area should not exceed 30 percent of the total landscaped area.
- c) Reuse gray-water, captured rain water and/or condensate water for irrigation to decrease potable water use for irrigation as well as to create a net benefit to the local watershed by making the landscape part of the natural water-treatment process.
- d) If gray-water or wastewater is to be recycled for landscape irrigation, tests should be conducted to determine suitability for reuse.
- e) Irrigation systems should be so designed that trees, shrubs and ground cover are irrigated in separate hydrazones such that watering can be discontinued zone by zone as plants become established.
- f) A sub surface drainage system shall be planned in areas covered with turf to collect excess water for reuse.

7.4 External Access Design

7.4.1 Reduced Environmental Impacts from Parking Facilities

Open parking areas, if largely made of concrete and asphalt, absorb heat and contribute substantially to the heat island effect. This shall be mitigated by following the considerations given below:

- a) Rendering these areas white or light in colour instead of black, so that they may reflect a lot of sunlight back to space rather than absorbing it.
- b) Providing shade and/or using light-coloured/high-albedo materials and/or open grid pavement for the site's non-roof impervious surfaces, including parking lots, walkways, plazas, etc.
- c) Limiting the net paved area of the site under parking, roads, paths, or any other use so as not to exceed 25 percent of the site area or net imperviousness of the site not to exceed the imperviousness factor as prescribed in **5.5.11.2.1** of the *National Building Code of India 2005: Part 9 Plumbing services: Section 1 Water Supply, Drainage and Sanitation*, whichever is more stringent.

Additionally the following shall be complied with:

- 1) More than 50 percent of the total paved area shall have pervious paving/open grid pavement/grass pavers, or
- 2) A minimum 50 percent of the total paved area (including parking) shall have shading by vegetated roof/pergola with planters, or
- 3) A minimum 50 percent of the total paved area (including parking) shall be topped with finish having solar reflectance of 0.5 or higher.

7.4.2 Long term Public and Private Transportation Plan

The long term public and private transportation plan shall take care of the following considerations:

- a) Incorporating urban transportation as an important parameter at the urban planning stage rather than being a consequential requirement;
- b) Encouraging integrated land use and transport planning in cities so that travel distances are minimized and access to livelihoods, education, and other social needs, specially for the marginal segments of the urban population is improved;
- c) Improving access of business to markets and the various factors of production;
- d) Bringing about a more equitable allocation of road space with people, rather than vehicles, as its main focus;
- e) Encouraging greater use of public transport and non-motorized modes;
- f) Enabling the establishment of quality focussed multi-modal public transport systems that are well integrated, providing seamless travel across modes;
- g) Establishing enforcement mechanisms to ensure efficiency and enhanced safety for the transport system users;
- h) Establishing institutional mechanisms for enhanced coordination in the planning and management of transport systems;
- i) Introducing intelligent transport systems for traffic management;
- j) Addressing concerns of road safety and trauma response;
- k) Reducing pollution levels through appropriate travelling practices, better enforcement, stricter norms, technological improvements, etc;
- l) Building capacity (institutional and manpower) to plan for sustainable urban

transport and establishing knowledge management system.

7.4.3 Bicycle Lanes and Pedestrian Access – Safety and Comfort

Construction of cycle tracks and pedestrian paths in cities enhances safety and thereby enhances use of non-motorized modes. The safety concern of cyclists and pedestrians should be addressed by encouraging the construction of segregated rights of way for bicycles and pedestrians. Apart from improving safety, the segregation of vehicles moving at different speeds helps improve traffic flow, increase the average speed of traffic and reduce emissions resulting from sub-optimal speeds. Such segregated paths are useful not only along arterials, to enable full trips using non motorist transport but also as a means of improving access to major public transport stations. Such access paths, coupled with safe bicycle parking places, may be provided for promoting an increased use of public transport. Creative facilities like shade giving landscaping, provision of drinking water and resting stations along bicycle corridors should also be encouraged to help mitigate, the effect due to adverse weather conditions. The use of the central verge along many roads, along with innovatively designed road crossings, may be considered for developing as cycle tracks. At busy intersections and high traffic corridors, pedestrian crossing shall be constructed.

Following are some of the features which should be considered while designing pedestrian and cycle/cycle-rickshaw friendly environment:

- a) Design and construction ensuring safety and comfort of the users.
- b) Use of following climatic design features for streets and public spaces to make them comfortable for pedestrians, cyclists and public transport users, based on local climate:
 - 1) Planting of deciduous trees all along the pedestrian/cycling path to provide adequate shade in summer and allow solar access in winter.
 - 2) Considerations to overhangs, arcades and closely built buildings providing shading and comfort in summer to the public realm.
 - 3) Orientation of streets to allow the desirable directional wind flow through streets and public spaces in summer and block undesirable winds in winter, to ensure comfort in the public use areas.
- c) Signalization of junctions and mid-block crossings on roads to allow safe crossings at grade.
- d) Multi-modal interchange and provision of good para-transport options and walkability at the neighbourhood level as the most important factor in reducing use of private modes and also reducing transportation demand and the following to be provided so that people can walk or cycle easily for short trips as well as for accessing mass transport stations:
 - 1) Fast and convenient interchange between modes (distances between modal changes to be as per multimodal integration and connectivity requirements).
 - 2) Closest convenient interchange access at stations for pedestrians, non-motorized modes and public/para-transport modes, preferably within 50 m of station exits.

- e) Proper street grid density as a critical requirement in urban design to ensure small blocks and an interconnected street network to provide a walkable, public transport friendly neighbourhood as per the following:
 - 1) Street grid density of 7-10 km centre-to-centre/km² for residential-mixed use neighbourhoods and 13-20 km centre-to-centre/km² for commercial-mixed use neighbourhoods to provide adequate connectivity and frequent directional changes for pedestrians.
 - 2) Direct and shortest route/access to station through provision of cut-throughs for pedestrians and non-motorized transport through blocks above 200 m in length with a view to making smaller block sizes.
 - 3) Signalization of junctions and mid-block crossings on roads to allow safe crossings at grade at a maximum frequency of 200 m.
- f) Provisions of dedicated lanes and signal prioritization for pedestrians, non-motorized transport and public transport on major corridors so as to provide priority and congestion-free movement for these modes.
- g) Adequate street lighting for pedestrians and bicycles to ensure their safety; minimum illuminance being 30 lux for non-shopping areas and 20 lux for shopping areas, bus stops and signalized crossings.
- h) Commercial/hawking zones at regular intervals in accordance with the local byelaws/ masterplan (within 5 minute walk from every home in the city) to encourage walkability and increased street activity and to provide safety.
- i) Amenities for public transport users:
 - 1) Amenities at-grade crosswalks (and overpasses on highways) at intervals of 80-200 m, aligning with location of transit stops, type of street/land use activities and neighbouring building entries and destinations,
 - 2) Dustbins, letter-boxes, signages and other public amenities at street corners for high usability.
 - 3) Accessible public toilets at every 500m-800m distance, preferably located close to bus stops for easy access by pedestrians and public transport users.
- j) Barrier free environment to make public streets and crosswalks fully navigable by all persons including the persons with disability and the aged with disabilities or reduce mobility.
- k) Vertical mixing of uses such that all non-work trips are reduced to be under 500 m walking distance such that vehicular trips may be eliminated for daily errands; for example through mixed convenient/ community shopping uses with residential uses to reduce dependency on private vehicle and shifting all short trips from private vehicle to walking, cycle-rickshaw or public transport.

7.4.4 Off Street Parking

The off street parking shall be planned taking care of the following objectives:

- a) To relieve congestion on streets by providing convenient off-street parking and loading facilities in proportion to the demand created by the use;

- b) To provide for the safe and orderly movement of traffic through proper design and location of adequate parking, loading, and manoeuvring areas;
- c) To protect neighbourhoods and surrounding land uses from vehicular parking, loading and traffic congestion, noise and dust, through proper aesthetic design and location of entries, parking areas, and landscaping;
- d) To promote businesses, industries and commercial activities by providing safe, convenient, attractive parking facilities and environments; and
- e) To encourage the use of efficient forms of transportation.

7.4.5 Discouraging Subsidized Parking in Public Realm

Subsidized parking in public roads and spaces, specially in urban areas with high traffic density or having likely projected high traffic density should be discouraged to reduce private vehicle usage and inducing a modal shift towards public transport. Parking management may be used as a demand management tool rather than a supply based tool, with the following considerations:

- 1) Discouragement to the use of car as a feeder or a general mode of transport, with park and ride facilities being only at stations of mass rapid transport system (MRTS).
- 2) Providing parking only for servicing rather than for access, and only emergency vehicle access to be provided which can be done through provision of mountable kerbs, etc on pedestrian dominated streets.
- 3) No free or subsidized parking in public space, and actual parking cost to be defined by market forces.
- 4) Enforcement of parking caps in areas with mass rapid transport access.
- 5) Park once-and-walk facilities in busy markets and residential/mixed use areas.
- 6) Strict enforcement of parking through self-regulating design.

7.4.6 Providing Neighbourhood Connectivity, Walkability and Safety

At the site design and block design level, several measures should be taken for reducing transportation demand and promoting walkability, and ensuring that the neighbourhood is a safe walkable place. These measures should include the following:

- a) Vertical mixing of housing and community based uses to ensure vibrancy and safety.
- b) Based on local climate, minimum 2-hour daylight access to neighbouring buildings to be ensured through provision of required street width-to-height ratios, in accordance with *National Building Code of India: Part 3 Development Control Rules and General Building Requirements*.
- c) Block sizes and paseos – For blocks where any one side is greater than 200 m in length, a public access cut-through for pedestrians and non-motorized transport (NMT) shall be provided. This ensures connectivity and walkability in the neighbourhood enabling short local trips to be made on foot.

- d) The setbacks and boundary wall for commercial properties should be designed so as to also promote safety and encourage pedestrian communication.

6.4.7 Ecology of Streets

As streets constitute about 20 to 25 percent of the impervious cover of the city, they have a large detrimental effect on the heat island effect and ecological character of a city. The following design components should be integrated in street design:

- a) Planting of trees as an essential component for all streets to provide shade to pedestrians and reduce solar gain.
- b) Use of high albedo (diffused reflectivity) materials for paving and increasing greenery around to reduce heat island effect.
- c) Decreasing impervious surfaces through permeable paving, tree planting zones, etc to increase ground water infiltration and prevent seasonal flooding.
- d) Integrate natural storm water filtration and absorption into street design through bio-filtration beds, bio-swales and detention ponds.

7.5 External Lighting Design

7.5.1 Landscape Lighting Design – Allowable Lighting Power Density (LPD)

Light pollution can disrupt circadian rhythms and melatonin production, which has been linked to serious health concerns. Reasonable use of outdoor lighting restores dark night skies and preserves the ambiance of the night. Whether outdoor light is directly adjacent to a species habitat or located at some distance is an important consideration, as through sky glow, the combined effects of artificial lighting on vast numbers of nocturnal species have the potential to disrupt the functioning of entire ecosystems by disturbing balances in competition and predation. The landscape lighting should be designed such that light fixtures emit minimum light as per the specified total fixed lumens and only light the areas as required for safety and comfort. In addition, the lighting shall be efficient complying with the requirements of maximum LPD given in Table 1.

Table 1 Maximum Lighting Power Densities for Building Exteriors

(Clause 6.5.1 and 6.5.3)

SI No.	Area to be Lit	LPDs Max
(1)	(2)	(3)
1)	Uncovered Parking Areas	
	i) Parking lots and drives	1.6 W/m ²
2)	Building Grounds	
	i) Walkways less than 10 feet wide	3.28 W/linearmetre
	ii) Walkways 10 feet wide or greater	

	Plaza Areas	2.15 W/m ²
	Special feature areas	
	iii) Stairways	10.76 W/m ²
3)	Building Entrances and Exits	
	i) Main entries	98.52 W/linear metre of door width
	ii) Other doors	65.68 W/linear metre of door width
4)	Canopies and Overhangs	
	i) Canopies (free standing and attached and overhangs)	13.45 W/m ²
5)	Outdoor Sales	
	i) Open Areas (including vehicle sales lots)	5.38 W/m ²
	ii) Street frontage for Vehicle sales lots in addition to "open areas" allowance	65.68 W/linear metre
6)	Building Facades	2.15 W/m ² for each illuminated wall or surface or 16.42 W/linear metre for each illuminated wall or surface length
7)	Automated Teller Machines (ATMs) and night depositories	270 W per location plus 90 W per additional ATM per location
8)	Entrances and Gatehouse inspection stations at guarded facilities	13.45 W/m ² of uncovered areas covered areas are included under the 'Canopies and Overhangs'
9)	Loading areas for law enforcement, fire, ambulance and other emergency service vehicles	5.38 W/m ² of uncovered areas covered areas are included in the 'Canopies and Overhangs'
10)	Drive-up windows at fast food restaurants	400 W per drive-through
11)	Parking near 24- hour retail entrance	800 W per main entry
12)	Landscaped areas, including individual house courtyards, terraces	2.15 W/m ²

7.5.2 External Signage Design

External signage may be designed to address the following main issues related to overall sustainability:

- a) The signage shall be classified as external lit and internal lit and further classified based on functional requirements such as emergency, way finding, etc. The requirements of each type of signage are different and should be evaluated based on the same. The recommended lighting power density is 129.17 W/m², max for internally illuminated signage, and 24.76 W/m², max for externally illuminated signage.
- b) Illuminated signage forms a substantial part of upward directed lighting. Efforts should be made to shield the lighting.
- c) Paints, adhesives, etc used in the signage should be of low VOC.
- d) Fabrication of the signage should be using materials locally available and having a recycled content.

7.5.3 External Lighting

The facades may be lit with fixtures that are shielded, with less than 10 percent lumens above 90° from the nadir (see Fig. 3) and the lighting power density of the façade lighting may be as given in Table 1.

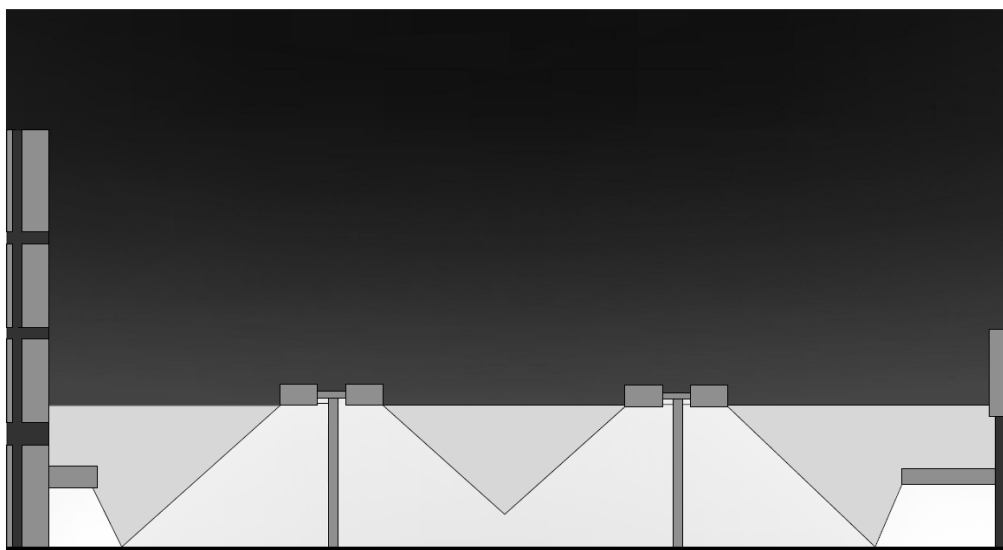

FIG. 3 FAÇADE LIGHTING USING SHIELDED FIXTURES

7.5.4 Light Trespass Allowance

The light trespass allowance may vary for different site surroundings, and a light should also vary for different settings depending upon the requirements. The site settings may be kept as:

- a) *Dark* – For rural setting.
- b) *Low lighting setting* – For residential areas/sub-urban areas and townships.
- c) *Medium-lighting setting* – For medium rise buildings, high rise buildings, commercial/office areas and high density for non-commercial area.
- d) *Highlighting setting* – For malls, entertainment areas and city centre areas.

8 ENVELOPE OPTIMIZATION

8.1 Building Envelope

The building envelope should be utilized to conserve energy substantially. Well designed building envelope maximizes daylight, natural ventilation (access to fresh air) and views to the exterior, and enables to modulate solar heat gain and control/reduce noise. The building envelope may also be designed to integrate systems for renewable and rainwater harvesting. In general, the design strategies drawn from long experience in the country in its various climatic zones may be taken into account (see Annex A for guidance).

Building envelope components and their configuration largely determine the amount of heat gain or loss and wind that enters inside the building. The primary components of building envelope which affect the performance of a building, are:

- a) Walls,
- b) Roof,
- c) Fenestration (openings with or without glazing),
- d) Floor, and
- e) Surface finishes.

8.1.1 Walls

Walls are a major part of the building envelope, which are exposed to external environment conditions such as solar radiation, outside air temperature, wind and precipitation. The construction of wall and thereby its heat storing capacity and heat conduction property has a major impact on indoor thermal comfort in naturally ventilated buildings and on cooling loads in air conditioned buildings. The wall material, thickness, finishes should be selected according to climate zone and building's comfort requirement. Wall properties that determine heat transfer are thermal conductivity, thermal resistivity, thermal absorptivity, emissivity, thermal reflectivity and thermal capacity (see 2).

8.1.1.1 Enhancement of thermal performance of walls

Thermal performance of walls can be improved by following ways:

a) Thermal insulation - Applying insulation on wall surface

Thermal insulation plays an important role in reducing the thermal conductance or U value of walls. The effect of insulation is to reduce heat gain and heat loss. Insulation should always be placed on the hotter side of the surface. In hot climate zone, insulation should be placed on the external side of wall composition. Insulation also controls the interior mean radiant temperature (MRT) by isolating the interior surfaces from the impacts of exterior conditions. Insulation along with infiltration control is important for reducing heating and cooling loads in skin load dominated buildings such as residences. In buildings, that are internal load dominated, use of excessive insulation may lead to higher energy consumption for cooling when the outdoor is cooler than indoors. These may be further supplemented through natural and/or mechanical ventilation. Thermal insulation may be made from a variety of materials and in several forms. Broadly they may be divided into following five categories:

- 1) Rigid or semi rigid blocks and boards,
- 2) Boards with impact or weather resistant surfaces suitable as exterior grade material,
- 3) Loose fill,
- 4) Foam and dry spray, and
- 5) Blankets, felts or sheets.

When specifying insulation, its key properties such as thickness, density, thermal resistivity/thermal conductivity value at specified temperature, fire resistance, moisture resistance, (structure open/closed cell), etc should be specified. Insulation should be applied as per manufacturers' recommendations and in a manner so that it achieves rated insulation in terms of thermal resistance or R value. Compressing the insulation reduces the effective R value and thermal performance of the construction assembly.

- b) *Thermal mass (Increasing wall thickness)* – Thermal mass in walls enables time delay in impact of external environment on internal conditions. Thermally massive walls have high thermal capacity, and thermal storage capacity increases with increasing compactness, density and specific heat capacity of the materials. Walls (and other building elements such as roof and floor) can be used for thermal storage. The effectiveness of storing heat or coolness can be increased by creating a flow of fluid through the storage media.

Thermal mass is particularly effective in hot–dry climate with larger diurnal range. The building mass stores heat during daytime when outside temperature is high, and releases it to the inside space during night when outdoor temperature is cooler. Thermal mass is also used in storing heat during daytime in cold climates, to release it into the space during night, to warm it up when outdoor conditions are colder. Materials such as concrete, brick and water have thermal storage capacity and can be used for such application. Storage mass exposed to direct sunlight should be dark in colour to allow larger absorption. It is generally more efficient to have thicker rather than thinner storage mass. The optimum thickness varies between 100mm and 200mm.

NOTE – There are ongoing developments based on research, regarding use of improvised materials with special properties such as phase changing characteristics which may be considered in future along with their implications from sustainability point of view.

- c) *Air cavities (Providing air cavities in walls)* – Air cavities in wall reduces solar heat gain factor. Performance is improved if the cavity is ventilated. Heat is transmitted through air cavity by convection and radiation. Cavity represents resistance that is not proportional to the thickness of the cavity. For thicknesses greater than 20 mm, the resistance to heat flow is nearly constant. Air cavity, however, may not be treated as replacement for higher insulation where needed as per the design requirements.
- d) *Surface finishes (applying light coloured paints on walls)* – Surface colour and finish plays an important role in heat gain and loss from a structure. If external surface of a building is painted with light colour, it will reflect solar radiation. But if the emissivity of the surface colour in the long wave region is high, the heat flux into the building is considerably reduced. For example, whitewash has a lower reflectivity than aluminium, but will stay cooler when exposed to high solar radiation, due to its high emissivity in the low temperature. The

effect of colour on external surfaces is more evident in lighter structure, which offers low resistance to heat flow, and because of low thermal capacity.

8.1.2 Roofs

The Roofs of buildings receive thrust of heat throughout the day. Predominantly used construction practices in the country specially in urban areas, mainly involve reinforced cement concrete (RCC) as the roofing element, which has high thermal conductivity. If the roof is exposed to solar heat, the temperature inside will also rise as the day progresses. When buildings are air conditioned, the purpose of the system is to maintain inside the building, a lower temperature than the ambient. If the roof slab is exposed to solar heat, it will allow continuous heat inside the building which in turn will add to the air conditioning load. If the roof is protected from heat, incidence by suitably insulating the roof from the heat the conditions inside can be controlled to a large extent so that the atmosphere inside the building remains below the ambient temperature throughout the day. The function of roof insulation is to insulate the building against heat in flow from outside during the day. The options for roof insulation are given in 8.1.2.1 to 8.1.2.3. The roof insulation provided shall achieve the minimum requirements specified in 3.2.8 of National Building Code of India: Part 8 Building Services: Section 3 Air-Conditioning, Heating & Mechanical Ventilation. Some traditionally adopted methods of roof construction like stone *patti* and jack-arched roof may be used after evaluating their thermal performance.

8.1.2.1 Over-deck insulation

In this system a thermal barrier or insulation is provided over RCC roof, so that the amount of heat of the Sun reaching the RCC slab of the roof is substantially reduced to prevent the slab from getting excessively heated up. In contrast if the thermal barrier is provided under RCC roof, as in under-deck insulation, some heat passes through it and heats up the ambience of the room. This decreases the comfort level of the room and if the building is air-conditioned, increases the air-conditioning load. Over-deck insulation is, therefore, considered advantageous over under-deck insulation in hot climates. Over-deck Insulation material should have adequate compression resistance, low water absorption, resistance to high ambient temperature and low thermal conductivity. Over-deck insulation applications may be carried out by either of the following methodologies:

a) *Use of preformed insulation materials* – Preformed insulation materials used are classified as given below which may be laid, over the roof surface as per the manufacturers' recommendations:

- 1) Expanded polystyrene sheet.
- 2) Extruded polystyrene sheet.
- 3) Polyurethane/polyisocyanurate sheet.
- 4) Perlite board.

b) *In-situ application using spray applied polyurethane* – This is applied directly over the roof by spraying. This insulation has advantage of non-interference with internal construction/operational activities of a building, jointless cover

to the roof surface due to seamless and monolithic nature of spray, and speedy application. However, this insulation needs to be treated with proper water proofing treatment ensuring no water ingress into the insulation, as in case of the waterproofing treatment getting damaged, the water ingress into the insulation may lead to deterioration and adversely affecting the insulation properties.

- c) *Conventional roof insulation practices* – There are a number of traditional roof insulation practices followed in the country which have been effectively employed. These may include mud *phuska* and brick bat *coba*.
- d) *Other traditional practices of roof insulation* – Inverted earthen pots may also be used for roof insulation. In this system burnt clay pots are placed in inverted positions and covered with filler material. The air trapped inside the pots act as insulator and renders insulating property to roof. Suitable water proofing treatment needs to be additionally applied. See also 9.2.4.1.1 (m)

The thermo-physical properties of different roof constructions are given in Table 2 and Table 3 for Flat Roof and Sloped Roof respectively.

Table 2 Typical Thermal Performance of Flat Roof Constructions

SI No.	Specification of Roof	U Values
(1)	(2)	(3)
		W/(m ² .K)
i)	100 mm RCC	3.59
ii)	100 mm RCC + 100 mm lime concrete	2.78
iii)	100 mm RCC + 50 mm foam concrete + waterproofing	1.08
iv)	50 mm RCC + 25 mm expanded polystyrene	1.08
v)	50 mm expanded polystyrene + 50 mm RCC + waterproofing	0.62
vi)	25 mm expanded polystyrene + 50 mm RCC	1.09
vii)	100 mm RCC + 50 mm cinder concrete + 50 mm brick tile	2.07
viii)	100 mm RCC + 75 mm cinder concrete + 50 mm brick tile	1.76
ix)	115 mm RCC + 50 mm Mud <i>Phuska</i> + 50 mm brick tile	2.31
x)	115 mm RCC + 75 mm Mud <i>Phuska</i> + 50 mm brick tile	2.01
xi)	150 mm clay unit	3.15
xii)	137.5 mm clay unit	2.99
xiii)	150 mm clay unit + 100 mm lime concrete	2.21
xiv)	137.5 mm clay unit + 100 mm lime concrete	2.14
xv)	100 mm cellular unit + 85 mm lime concrete	2.27
xvi)	125 mm cord unit + 85 mm lime concrete	2.13
xvii)	154 mm lime concrete using stone aggregate + 76 mm stone slab	3.07
xviii)	88.9 mm concrete using brick aggregate + 25.4 mm Kota stone slab on each side	3.65
xix)	50.8 mm lime concrete using ballast aggregate + 114 mm reinforced brick and bitumen wash on top	2.45
xx)	50.8 mm lime concrete using brick ballast aggregate + 50.8 mm RCC slab + bitumen wash on top surface	4.02
xxi)	100 mm RCC + Inverted clay pots with mud <i>phuska</i>	2.344

xxii)	100 mm RCC + Extruded polystyrene 25mm-36kg/m ³	0.749
xxiii)	100 mm RCC + Extruded polystyrene 30mm-36kg/m ³	0.658
xxiv)	100 mm RCC + Extruded polystyrene 40mm-36kg/m ³	0.528
xxv)	100 mm RCC + Extruded polystyrene 60mm-36kg/m ³	0.380
xxvi)	100 mm RCC + Extruded polystyrene 75mm-36kg/m ³	0.312
xxvii)	100 mm RCC + Expanded polystyrene 25mm-24kg/m ³	0.931
xxviii)	100 mm RCC + Expanded polystyrene 30mm-24kg/m ³	0.823
xxix)	100 mm RCC + Expanded polystyrene 40mm-24kg/m ³	0.670
xxx)	100 mm RCC + Expanded polystyrene 60mm-24kg/m ³	0.482
xxxi)	100 mm RCC + Expanded polystyrene 75mm- 24 kg/m ³	0.409
xxxii)	100 mm RCC + Phenolic foam 25mm-32 kg/m ³	0.725
xiii)	100 mm RCC + Phenolic foam 30mm-32 kg/m ³	0.641
xxxiv)	100 mm RCC + Phenolic foam 40mm-32 kg/m ³	0.511
xxxv)	100 mm RCC + Phenolic foam 60mm-32 kg/m ³	0.363
xxxvi)	100 mm RCC + Phenolic foam 75mm-32 kg/m ³	0.301
xxxvii)	100 mm RCC + Polyurethane spray 25mm-42+ 2 kg/m ³	0.664
xxxviii)	100 mm RCC + Polyurethane spray 30mm-42+ 2 kg/m ³	0.579
xxxix)	100 mm RCC + Polyurethane spray 40mm-42+ 2 kg/m ³	0.460
xL)	100 mm RCC + Polyurethane spray 60mm-42+ 2 kg/m ³	0.319
xLi)	100 mm RCC + Polyurethane spray 75mm-42+ 2 kg/m ³	0.259
xLii)	100 mm RCC + Polyisocyanurate spray 25mm-42+ 2 kg/m ³	0.664
xLiii)	100 mm RCC + Polyisocyanurate spray 30mm-42+ 2 kg/m ³	0.579
xLiv)	100 mm RCC + Polyisocyanurate spray 25mm-42+ 2 kg/m ³	0.460

Table 3 Typical Thermal Performance of Sloped Roof Constructions

SI No.	Specification of Sloped Roof	U Values
(1)	(2)	(3)
		W/(m ² .K)
i)	0.625 cm AC sheet	5.47
ii)	0.625 cm AC sheet + 2.5 cm air space + insulating board	2.44
iii)	0.625 cm AC sheet + air space + 5 cm fibre glass + 0.625 hard board	1.40
iv)	0.625 cm AC sheet + air space + 5 cm sandwich of fibreboard/ expanded polystyrene	0.65
v)	0.625 cm AC sheet + air space + 2.5 cm sandwich of fibreboard/ expanded polystyrene	1.22
vi)	0.3 cm GI sheet	6.16
vii)	2.5 cm tile + 2.5 cm bamboo reinforcement	3.56
viii)	5 cm tile + 2.5 cm bamboo reinforcement	3.20
ix)	2.5 cm thatch roof + 2.5 cm bamboo reinforcement	2.38
x)	5 cm thatch roof + 2.5 cm bamboo reinforcement	1.69
xi)	Mangalore tiles on wooden rafters	4.07

NOTE: Thermal conductivity values are indicative and many other/traditional practices may be employed for achieving desired thermal properties.

Thermal properties of some commonly used insulating materials and building materials are given in Table 4.

Table 4 Thermal Properties of Building and Insulating Materials at Mean Temperature of 50 °C

SI No.	Type of Material	Density	Thermal Conductivity	Specific Heat Capacity
(1)	(2)	(3)	(4)	(5)
		(kg/m ³)	(W/mK)	(kJ/kgK)
<i>Building Materials</i>				
1	Burnt brick	1 820	0.811	0.88
2	Mud brick	1 731	0.750	0.88
3	Dense concrete	2 410	1.74	0.88
4	RCC	2 288	1.58	0.88
5	Limestone	2 420	1.80	0.84
6	Stale	2 750	1.72	0.84
7	Reinforced brick	1 920	1.10	0.84
8	Brick tile	1 892	0.798	0.88
9	Lime concrete	1 646	0.730	0.88
10	Mud Phuska	1 622	0.519	0.88
11	Cement mortar	1 648	0.719	0.92
12	Cement plaster	1 762	0.721	0.84
13	Cinder concrete	1 406	0.686	0.84
14	Foam slag concrete	1 320	0.285	0.88
15	Gypsum plaster	1 120	0.512	0.96
16	Cellular concrete	704	0.188	1.05
17	AC sheet	1 520	0.245	0.84
18	GI sheet	7 520	61.06	0.50
19	Timber	480	0.072	1.68
20	Timber	720	0.144	1.68
21	Plywood	640	0.174	1.76
22	Glass	2 350	0.814	0.88
23	Alluvial clay (40 percent sands)	1 958	1.211	0.84
24	Sand	2 240	1.74	0.84
25	Black cotton clay (Madras)	1 899	0.735	0.88
26	Black cotton clay (Indore)	1 683	0.606	0.88
27	Tar felt (2.3 kg/m ²)	-	0.479	0.88
<i>Insulating Materials</i>				
1	Expanded polystyrene	16.0	0.038	1.34
2	Expanded polystyrene	24.0	0.035	1.34

3	Expanded polystyrene	34.0	0.035	1.34
4	Foam glass	127.0	0.056	0.75
5	Foam glass	160.0	0.055	0.75
6	Foam concrete	320.0	0.070	0.92
7	Foam concrete	400.0	0.084	0.92
8	Foam concrete	704.0	0.149	0.92
9	Cork slab	164.0	0.043	0.96
10	Cork slab	192.0	0.044	0.96
11	Cork slab	304.0	0.055	0.96
12	Rock wool (unbonded)	92.0	0.047	0.84
13	Rock wool (unbonded)	150.0	0.043	0.84
14	Mineral wool (unbonded)	73.5	0.030	0.92
15	Glass wool (unbonded)	69.0	0.043	0.92
16	Glass wool (unbonded)	189.0	0.040	0.92
17	Resin bonded mineral wool	48.0	0.042	1.00
18	Resin bonded mineral wool	64.0	0.038	1.00
19	Resin bonded mineral wool	99.0	0.036	1.00
20	Resin bonded mineral wool	16.0	0.040	1.00
21	Resin bonded mineral wool	24.0	0.036	1.00
22	Exfoliated vermiculite (loose)	264.0	0.069	0.88
23	Asbestos mill board	1 397.0	0.249	0.84
24	Hard board	979.0	0.279	1.42
25	Straw board	310.0	0.057	1.30
26	Soft board	320.0	0.066	1.30
27	Soft board	249.0	0.047	1.30
28	Wall board	262.0	0.047	1.26
29	Chip board	432.0	0.067	1.26
30	Chip board (perforated)	352.0	0.066	1.26
31	Particle board	750.0	0.098	1.30
32	Coconut pith insulation board	520.0	0.060	1.09
33	Jute fibre	329.0	0.067	1.09
34	Wood wool board (bonded with cement)	398.0	0.081	1.13
35	Wood wool board (bonded with cement)	674.0	0.108	1.13
36	Coir board	97.0	0.038	1.00
37	Saw dust	188.0	0.051	1.00
38	Rice husk	120.0	0.051	1.00
39	Jute felt	291.0	0.042	0.88
40	Asbestos fibre (loose)	640.0	0.060	0.84

For thermal performance of flat and sloped roofs with use of various other considerations of materials and for thermal properties of building and insulating materials, refer good practice [11(2)] and SP41 Handbook on Functional Requirements of Buildings.

- e) *Other over-deck insulation systems* – There are other systems employing use of highly reflective and emissive materials that stay cooler in the summer thereby reducing energy costs, improving occupant comfort, cutting

maintenance costs, increasing the life of the roof, and contributing to the reduction of heat island effect and associated smog. Roofs with slopes less than 20 degree slope have a minimum initial solar reflectance of 0.70 and minimum emittance of 0.75. Cool roofs should be designed to have a minimum solar reflectance of 0.70 and a minimum thermal emittance of 0.75 or alternatively should achieve a minimum solar reflective index (SRI) of 82. Various types of cool roof systems are:

- 1) *Roof coatings* – These may be field applied or factory applied. Field applied roof coatings are applied directly onto the roof surface and may require an appropriate primer. Factory applied coatings are applied in factory and include coatings applied to metal sheets. Specialized white elastomeric coatings may be used for sloped roofs and cool colour polymer coatings may be used for roof tiles, and these can be sprayed on existing roofs.
- 2) *Broken china mosaic terracing* – Well graded broken pieces of glossy glazed tiles may be used for conducive cool roofing as cost-effective option.
- 3) *Modified Bitumen* – It is bitumen (asphalt or tar) modified with plastic and layered with reinforcing materials then topped with a surfacing material.
- 4) *Cool colours* – Cool colour roofing materials are created by integrating pigments that reflect infrared energy, even though their colour may still absorb some of the visible spectrum. In this way, roofing products can be dark coloured and still be cool.
- 5) *Traditional methods* – Lime wash also renders similar property but has limited life and has to be reapplied.

8.1.2.2 Green roof system

Green roofs have the potential to improve the thermal performance of a roofing system through shading, insulation, evapo-transpiration and thermal mass, thus reducing energy demand of building for space conditioning. The green roof moderates the heat flow through the roofing system and helps in reducing the temperature fluctuations due to changing outside environment. If widely used, green roofs can reduce the problem of heat island effect which in turn reduces the energy consumption in urban areas. Green roof systems comprise a lightweight growing medium, plants and a root repellent layer in addition to the regular components of a roof. The additional components and thickness of the growing medium provides thermal insulation, while the green cover lowers ambient temperatures through evapo-transpiration. There are three types of green roofs, as follows:

- a) *Intensive green roof* - It is like a conventional garden or park with almost no limit on the type of available plants including trees and shrubs.
- b) *Extensive green roof* - It is designed for little maintenance or human intervention once it is established.

- c) *Modular block green roof* - It is designed in modular units which interlock and each module contains drainage systems and plants.

8.1.3 Fenestration

8.1.3.1 Of all the elements of building envelope, windows and glazed areas are most vulnerable to heat gains. Windows are required to bring inside natural daylight and wind, however, with light it also bring in heat. Proper location, sizing and detailing of windows and shading form is therefore a very important aspect in a solar passive building design. Primary factors/components of a window which have significant impact on energy and cost of the building are window size and placement, glazing, frame, shading (external and internal), and screens or *jalis*.

8.1.3.1.1 Window size and placement

The following may be taken into consideration:

- a) *Height of window head* – The higher the window head, the deeper will be the penetration of daylight.
- b) *Sill height (height from floor to the bottom of the window)* – The optimum sill for good illumination as well for good ventilation should be between the workspace and head level of a person. For carrying out any task, the suitable work plane levels shall be in accordance with **4.1.3.3** of *National Building Code of India: Part 8 Building Service: Section 1 Lighting and Ventilation*. Strip windows provide more uniform daylight. Punched windows should be paired with work areas to avoid creating contrasts of light and dark areas. Windows close to task areas should be with optimum visual transmission with good insulation performance as they may be source of thermal discomfort. Small horizontal openings close to the floors and the ceiling are extremely effective in reducing the window area to reduce heat ingress and provide adequate daylight levels in the space. In case of larger windows, glazing selection and shading effectiveness are quite important to control glare and heat gain.
- c) *Use of separate apertures for view and daylight* – For good day lighting and glare control, window should have clear glass with for maximum daylight penetration and tinted glass below the clear glass for glare control. The structure in between the two provides a visual break and an opportunity to attach light shelf or shading device.
- d) *Window wall ratio (WWR)* – Window to wall ratio is the net glazing area (window area minus mullions and frame or approximately 80 percent of opening) divided by gross exterior wall area. Gross wall area is the overall area of a wall including openings such as windows and doors, with measurement taken horizontally from outside surface to outside surface and measured vertically from top of the floor to the top of the roof (see Fig. 5).

NOTE – The above represents only one approach in the entire range of window to wall ratio. The issue is primarily of window to wall ratio, and not window to glazing ratio.

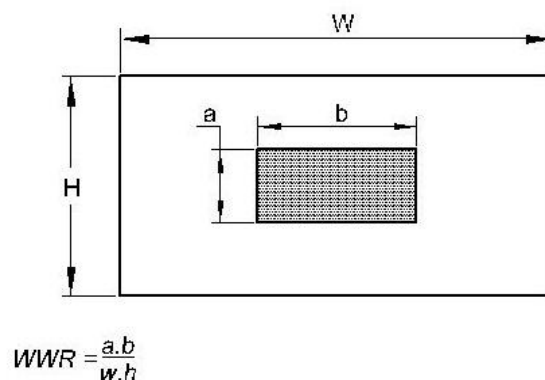
**FIG. 4 WINDOW WALL- AREA**

Screens make effective windows which reduce heat ingress and yet allow the Air movement.

8.1.3.1.2 Glazing

The most commonly used glazing material in openings is glass, though recently polycarbonate sheets are being used for skylights. The primary properties of glazing that impact energy use are:

- a) Visible transmittance (affecting daylight),
- b) Visible reflectance (affecting heat and light reflection),
- c) Thermal transmittance or U value (affecting conduction heat gains),
- d) Solar heat gain (affecting direct solar gain),
- e) Spectrum selectivity (affecting daylight and heat gain),
- f) Glazing material, and
- g) Glazing colour (affecting the thermal and visual properties of glazing systems).

Use of insulated glazing units (IGU) may be considered in appropriate cases. IGU are hermetically sealed, multiple pane assemblies consisting of two or more glazing layers held and bonded at their perimeter by a space bar typically containing a desiccant material. The glazing used in IGUs may be clear, tinted or coated or reflective. The spacer serves to separate the panes of glass and to provide a surface for primary and secondary sealant adhesion. As heat transfer at the edge of the IGU is greater than its centre, the choice of material for spacer is critical to the performance of IGU. The hermetically sealed space between glass panes may be filled with air or other alternatives such as argon and krypton.

While selecting a glazing, attention should be given to the following:

- 1) Selecting between dual pane and single pane glazing.
- 2) Selecting a spectrally selective glazing.
- 3) Balancing the conflict between glare and light.
- 4) Trading off window size and glazing selection.

- 5) Dark glass not necessarily providing good solar control.
- 6) Not depending on glazing alone to reduce heat gain and discomfort.
- 7) Selection of frame for glazing. (See **8.1.3.1.3**)
- 8) Varying the selection of facade, if possible.

8.1.3.1.3 Frame

The type and quality of window frame affects air infiltration and heat gain/heat loss characteristics of window. Window frames are usually made of aluminium, steel, wood, PVC, fibreglass or composites of these materials. Wood, fibreglass, and vinyl frames are better insulators than metal. Some frames are designed with internal thermal breaks that reduce heat flow through the frame. These thermally broken frames can resist heat flow considerably better as compared to those without thermal breaks.

For further details, reference may be made to **9.2.3.2**.

8.1.3.1.4 Shading devices

Direct sunlight can cause glare. Controls are therefore necessary to allow diffused natural light. Windows shading devices may be employed which help in keeping out the heat, block uncomfortable direct Sun, and soften harsh daylight contrasts. Shading devices are also critical for visual and thermal comfort and for minimizing mechanical cooling loads. The three main ways of controlling direct sunlight:

- a) External shading and screens/*jalis*,
- b) Internal shading, and
- c) Use of solar control glass.

8.1.3.2 Design for windows in air-conditioned and non air-conditioned spaces

8.1.3.2.1 Windows in air-conditioned buildings

Window (including both glazing and frame) affects the energy performance of a conditioned space by impacting the HVAC energy consumption of the building and by the Lighting energy consumption. Following are major types of energy flow which occur through a window impacting the HVAC energy consumption (see *also* Fig. 5):

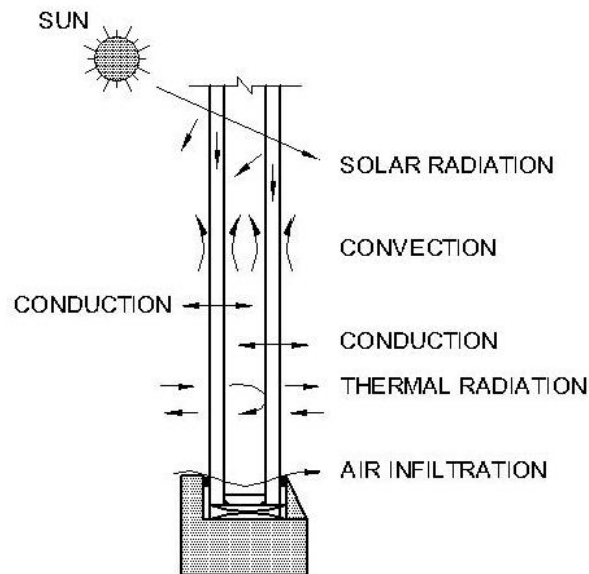

FIG. 5 TYPICAL FLOW OF SOLAR HEAT AND AIR INFILTRATION

- a) *Non-solar heat losses and gains in the form of conduction, convection, and radiation* – The non-solar heat flow through a window occurs due to the temperature difference between the indoor and outdoor. Window loses heat to the outside during the winter season and gains heat from the outside during the summer season, adding to the energy needs in a building.
- b) *Solar heat gains in the form of radiation* –The direct solar radiation entering into a conditioned space adds to the cooling load in summers and reduces heating load in winters in a building.
- c) *Infiltration* – Infiltration is the uncontrolled leakage of air into a space from the outside through joints and cracks around window frame, sash and glazing. The air tightness of a window depends on both the characteristics of the window such as sash type and overall quality of window construction and the quality of the installation.

Following are various parameters, related to the thermal performance of a window which should be considered to achieve energy efficiency in a air conditioned building:

- 1) *U factor of fenestration* – The U factor of a single pane window is mainly due to the thin films of still air on the interior and moving air on the exterior glazing surfaces. The glazing itself doesn't offer much resistance to heat flow. Double glazing units, help reduce the U factor by creating still air spaces. In addition to the normal double glazed windows, other options aimed at decreasing U factors, such as low-emittance (low-E) coatings and gas fills, may also be available.

A low-E coating is a microscopically thin, virtually invisible, metal or metallic oxide coating deposited on a glazing surface. The coating may be applied to one or more of the glazing surfaces facing an air space in a multiple-pane window. The coating limits radiative heat flow between

panes by reflecting heat back. In case of air filled panes, the air-gap between window panes can be filled with gases which have better thermal resistance property than air such as argon and krypton.

For details regarding window frames and their thermal performance, reference may be made to **8.1.3.1.3**.

- 2) *Solar heat gain coefficient (SHGC) of fenestration* – Additional glazing layers provide more barriers to solar radiation, thus reducing the SHGC of a window. Tinted glazings, such as bronze and green, provide lower solar heat gain coefficients compared to the clear glass. Spectrally selective glazings, including some low-E coated glazings with low solar heat gain, block out part of the heat from the Sun while maintaining higher visible transmittances.
- 3) *Shading and adjusted SHGC* – Exterior or interior shading devices such as awnings, louvered screens, sunscreens, venetian blinds, roller shades, and drapes can complement and enhance the performance of windows with low SHGC. Many shading devices have an advantage that they can be adjusted to vary solar heat transmission with the time of day and season.

Exterior shading devices are more effective than interior devices in reducing solar heat gain because they block radiation before it passes through a window. Light-coloured shades are preferable to dark ones because they reflect more, and absorb less, radiation.

- 4) *Projection factor(PF)* – The projection factor for horizontal overhang and vertical fins may be taken as follows:

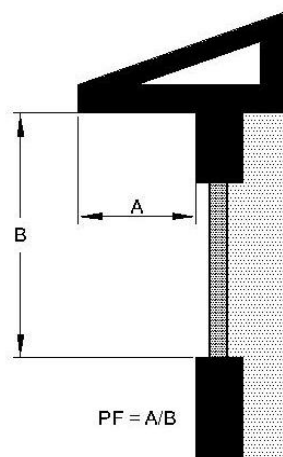

FIG. 6 PROJECTION FACTOR FOR HORIZONTAL OVERHANG

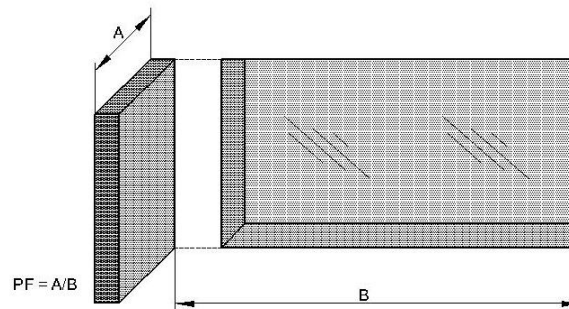

FIG. 7 PROJECTION FACTOR FOR VERTICAL FIN

- i) For horizontal overhang – Projection factor for overhang is calculated by measuring the depth of the overhang (A) and dividing that by the distance from the bottom of the window to the lowest point of the overhang (B) (see Fig. 6).
- i) SHGC for a window having an external shading device can be calculated by multiplying the SHGC value of the window with the M factor given in Table 5 for different projection factors for different orientations. The factor M is the relative reduction in the annual solar cooling load for overhangs and/or vertical fins with the given projection factor.
 - ii) For vertical fins – Projection factor for vertical fin is calculated by measuring depth of the vertical fin and dividing it by the distance from the window jamb to the farthest point of the external shading projection (see Fig. 6).

Table 5 M Factor for Different Projection Factors for Different Orientations
(Clauses 7.1.3.2.1(4)(ii) and B-3)

Location	Orientation	Overhang M Factor for the Projection Factor				Vertical Fin M Factor for Projection Factor				Overhang + Vertical Fin M factor for projection factors			
		0.25 to 0.49	0.50 to 0.74	0.75 to 0.99	More than 1.00	0.25 to 0.49	0.50 to 0.74	0.75 to 0.99	More than 1.00	0.25 to 0.49	0.50 to 0.74	0.75 to 0.99	More than 1.00
(1)	(2)	(3)	(4)	(5)	(6)	(7)	(8)	(9)	(10)	(11)	(12)	(13)	(14)
15° North Latitude or greater	N	0.88	0.80	0.76	0.73	0.74	0.67	0.58	0.52	0.64	0.51	0.39	0.31
	E/W	0.79	0.65	0.56	0.50	0.80	0.72	0.65	0.60	0.60	0.39	0.24	0.16
	S	0.79	0.64	0.52	0.43	0.79	0.69	0.60	0.56	0.60	0.33	0.10	0.02
Less than 15° North Latitude	N	0.83	0.74	0.69	0.66	0.73	0.65	0.57	0.50	0.59	0.44	0.32	0.23
	E/W	0.80	0.67	0.59	0.53	0.80	0.72	0.63	0.58	0.61	0.41	0.26	0.16
	S	0.78	0.62	0.55	0.50	0.74	0.65	0.57	0.50	0.53	0.30	0.12	0.04

- 5) *Impact on lighting energy consumption* – During day time when natural light outside, is available in abundance, window can be utilized as a tool to harness natural light from Sun and sky to light the space. Buildings, in which artificial lighting is integrated with the day lighting, can reduce their

energy consumption significantly. Good day lighting in a building depends upon the following factors:

- i) *Window Wall Ratio (WWR)* – See 8.1.3.1.1(d)
- ii) *Visible Light Transmittance (VLT) of glazing.*
- iii) *Day-lighting and window design* – Day lighting is utilization of light from the sun and sky to complement or replace electric light. Appropriate fenestration and lighting controls can be used to modulate daylight admittance and to reduce electric lighting, while meeting the occupants' visual comfort.
- iv) *Day-lit perimeter zone for vertical fenestration* – The day-lit zone associated to a window can be defined as an area having a depth which is twice the window height (measured from ground) and having the width which is equal to the window width plus 1.0 m on each of the vertical sides of window as indicated in the Fig. 8.

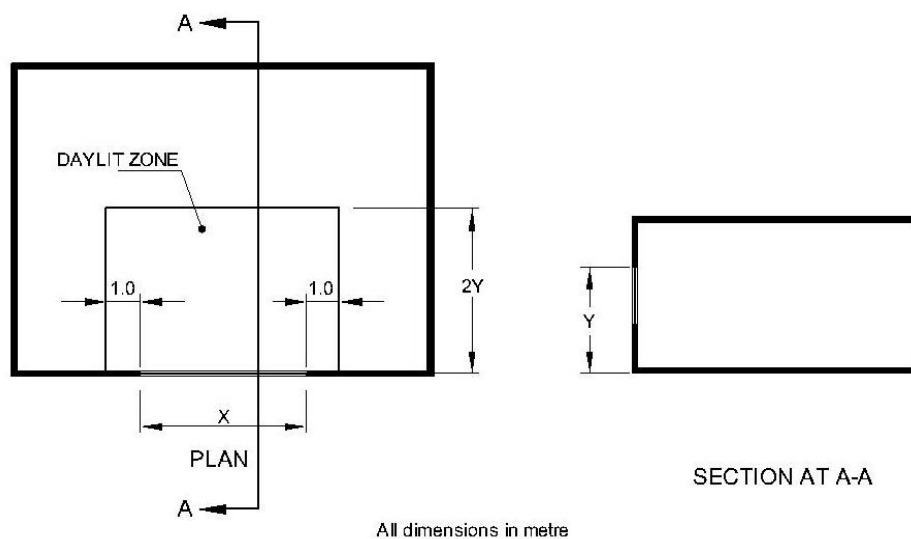

Dimension of Day-lit perimeter: Depth (m) = $2 \times Y$; Width (m) = $X + 1 + 1$.

FIG. 8 DAY-LIT PERIMETER ZONE ASSOCIATED TO A WINDOW

The fenestration area, located above 1.0 m but below 2.2 m is considered as vision window area. The vision window area is usually provided with the glass with lower VLT in order to reduce glare.

The fenestration area located above 2.2 m is considered as daylight window area. Larger the daylight window area more will be the daylight penetration into a space. The daylight window area is usually provided with glass with higher VLT so as to receive daylight to the greater depths of the space. The daylight window area can be designed in form of light shelves, as shown in Fig. 9, which enhance the penetration of daylight.

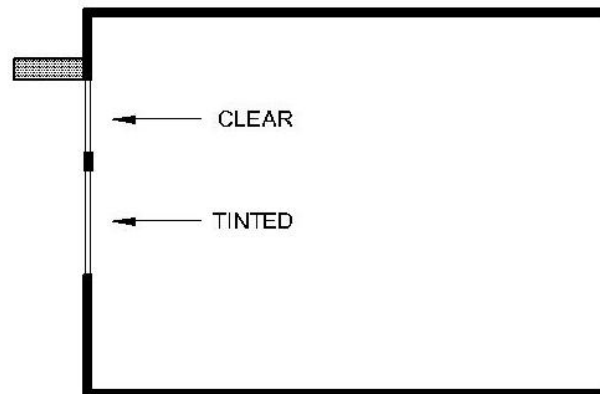

FIG. 9 ARRANGEMENT SHOWING VISION WINDOW AREA AND DAY LIGHT WINDOW AREA

The following should be determined and shall conform to the requirements of this Code:

- a) *U*-factor for a fenestration product (including the sash and frame).
- b) The SHGC for a fenestration product (including the sash and frame).
- c) Air leakage through fenestration, shall not exceed 2.0 litres/s m².
- d) Window wall ratio on a facade, correlated to the visible light transmittance of the glazing which shall not exceed 60 percent.

NOTE – It may be noted that screens make effective windows which reduce heat ingress and yet allow the air movement and may be used.

8.1.3.2.2 Window design guideline for non-conditioned buildings

As compared to air-conditioned space, the window design in non-conditioned buildings takes a different approach. The glazing system for windows in non-conditioned spaces is usually single glazed units as the windows will be opened to allow ventilation thus there is less relevance to install double glazing units with low SHGC and *U*-factor values.

In the non-conditioned buildings the shading device plays a crucial role in the thermal performance of a window. Windows on facades, facing different cardinal directions, should be provided by the shading devices which can cut the direct incident solar radiation for the critical solar angles.

In the non-conditioned buildings, penetration of direct solar radiation needs to be regulated. The critical Horizontal Solar Angle (HSA) and Vertical Solar Angle (VSA) (see Fig.1) for fenestrations located on the cardinal directions should be cut down by designing appropriate shading devices. The horizontal solar angle at critical hours can be cut by the vertical fins provided as external shading device. The vertical solar

angle at critical hours can be cut by the horizontal fins provided as external shading device.

The maximum permissible WWR on a facade should not exceed 60 percent. Window opening requirement for naturally ventilated low rise residential and office buildings are:

- a) Window openings, in order to allow outside air to enter the space, should orient between 45° to the East-West direction to optimize heat and solar heat gain
- b) Location of window openings, in order to facilitate cross ventilation, should be located opposite to each other on walls parallel to each other. The location of windows should be preferably on east and west walls functioning as inlet and outlet openings to maximize ventilation of the space, subject to the orientation options available.
- c) In order to achieve the required air change per hour in a given space, cross ventilation and stack ventilation mode of natural ventilation should be used.

The external shading devices can be designed in various ways to stop the solar radiation entering through the window. The Fig.10 shows the commonly used shading devices.

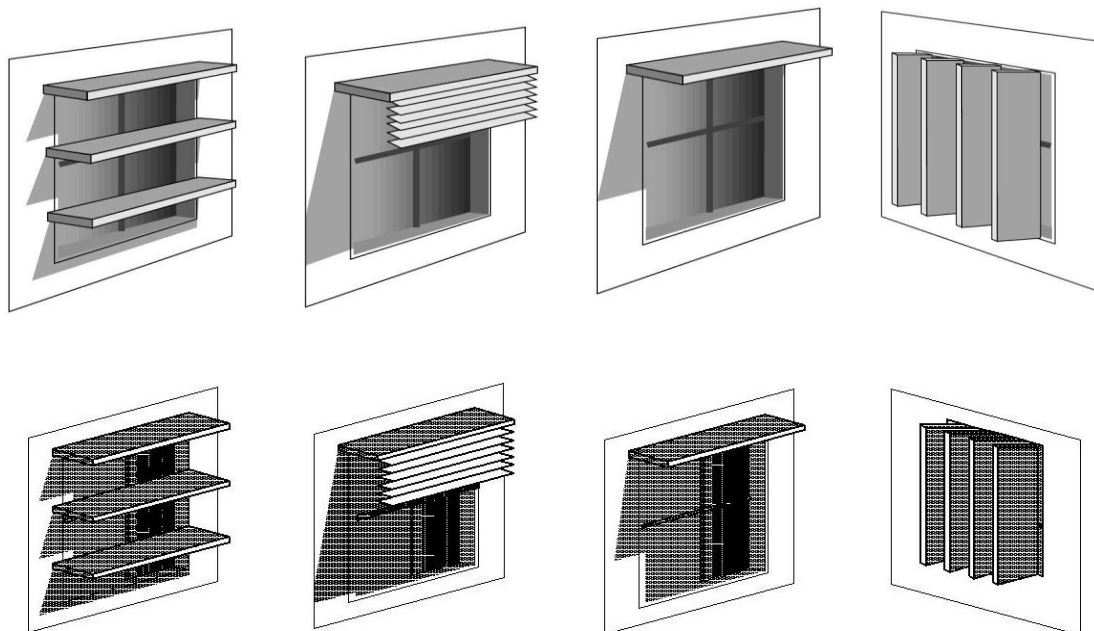

FIG. 10 COMMONLY USED SHADING DEVICES

Example to design shading device for a window

Design of shading device for a window of height 1.5 m and width 3.0 m to cut the HSA of 45° and VSA of 60° should be as follows:

Design of shading device to cut the VSA

The vertical solar angle of 60° can be cut by providing a single horizontal overhang of length 866 mm or it can be cut by providing two horizontal projections 60 mm thick each of length 416 mm placed at a distance of 750 mm as shown in Fig. 11.

The length and spacing can be calculated either by the drafting softwares by graphical method or by manually calculating using the following formula:

Depth of shading device = Spacing between the shading device $\times \tan (90^\circ - \text{VSA})$

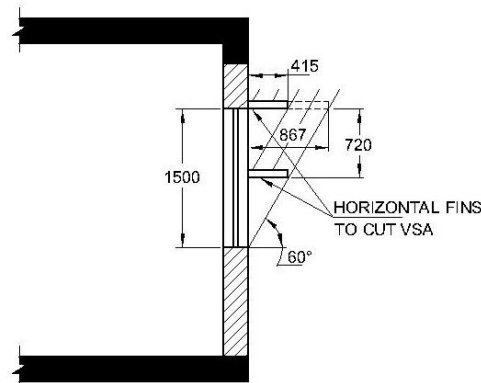

SECTION IN ELEVATION

All dimensions are in millimetres

FIG. 11 DESIGN OF SHADING DEVICE TO CUT VSA

For a given VSA either of the values for depth or spacing between shading overhangs can be selected to get the value of the other.

Design of shading device to cut the HSA

The horizontal solar angle of 45° can be cut by providing a single vertical fin of length 3000 mm or it can be cut by providing four vertical fins 60 mm thick each of length 705 mm placed at a distance of 705 mm as shown in Fig. 12.

The length and spacing can be calculated either by the drafting softwares by graphical method or by manually calculating using the formula:

Depth of vertical fins = Spacing between the vertical fins $\times \tan (90^\circ - \text{HSA})$

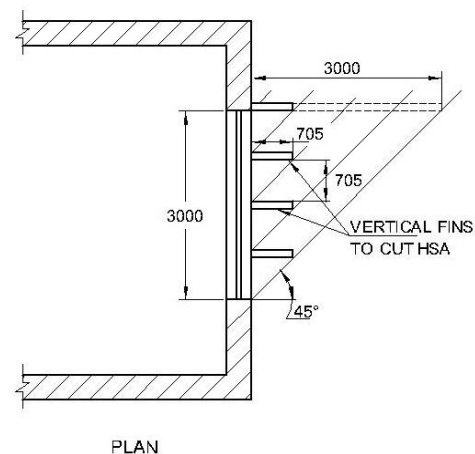

All dimensions are in millimetres

FIG. 12 DESIGN OF SHADING DEVICE TO CUT HSA

For a given HSA either of the values for depth or spacing between vertical fins can be selected to get the value of the other.

It is desirable to break single overhang with larger depth into multiple overhangs of smaller length. It enhances the amount of daylight penetration in the space. Fig. 13 shows the comparison between amount of daylight penetration for two shading devices, one with single deep overhang and the other with multiple smaller overhangs. Another alternative is use of screens which make effective window/opening protection which reduce heat ingress and yet allow the air movement.

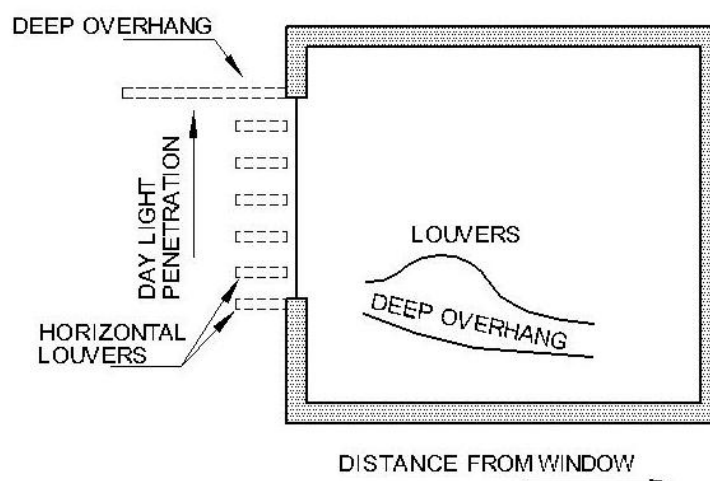

FIG. 13 COMPARISON OF DAYLIGHT PENETRATION WITH USE OF TWO SHADING DEVICES NAMELY DEEP OVERHANGS AND LOUVERS

Window design for natural ventilation – Windows are required to achieve natural cooling through ventilation. Optimized window design helps to achieve thermal comfort with no additional financial investment. Optimized window design helps to

reduce dependence on air conditioning where natural ventilation is possible and helps in reducing discomfort in naturally ventilated spaces. Following are the general guidelines for achieving effective natural ventilation:

- a) Naturally ventilated buildings should take advantage of the predominant wind originating from east and west directions to maximize cross ventilation. Stack ventilation can be enhanced by providing openings on the opposite side of the wall, where the inlet opening should be located at the bottom most part of the wall and outlet openings should be on the topmost part of the wall in order to increase the height difference between the two (see Fig. 14).
- b) Naturally ventilated buildings should have a narrow floor width; and it is difficult to naturally ventilate buildings with floor depth more than 15m.
- c) For total area of openings (inlet and outlet) of 20 to 30 percent of floor area, the average indoor wind velocity that may be achieved is around 30 percent of outdoor wind velocity. Even on increasing the size of window further, the maximum indoor wind velocity does not exceed 40 percent of outside wind velocity.

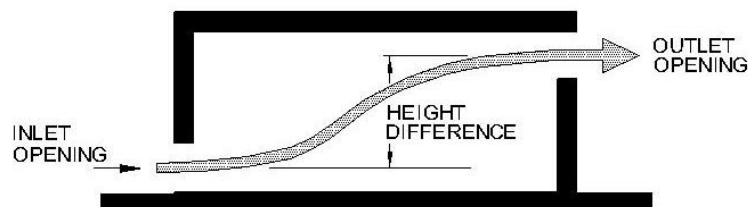

FIG. 14 ARRANGEMENT OF OPENINGS IN WALLS FOR ENHANCED VENTILATION

- d) To enhance physiological cooling, the bottom side of the opening may be kept at 85 percent of the height of the room taken from ceiling or as per Table 6 for the related pattern of activities.

Table 6 Critical Height Requirement for Physiological Cooling

Pattern of Activities	Recommended Height of the Bottom Side of Opening
Sitting on chair	0.75 m
Sitting on bed	0.60 m
Sitting on floor	0.40 m

- e) Clerestory or vented skylight provides an opening for stale air to escape in a buoyancy ventilation strategy. The light well of the skylight may also act as a solar chimney to augment the flow.
- f) Openings in lower part of the structure, such as basement windows, should be provided to complete the ventilation system.

8.2 Envelope Optimization Methods for Energy Efficiency

Envelope optimization methods are important tools for optimizing the design of building envelope from energy efficiency point of view. Any of the following envelope optimization methods may be employed to achieve the objective:

- a) *Prescriptive method* – This method specifies a set of prescriptive requirements for building systems and components. Compliance with these requirements can be achieved by meeting or exceeding the specific levels described for each individual element of the building systems. Envelope optimization using this method shall be carried out in accordance with Annex B.
- b) *Trade-off method* – This is a systems-based approach, where the thermal performance of individual envelope components can be reduced if compensated by higher efficiency in other building components (for example, using higher wall insulation could allow for a less stringent U-factor requirement for windows, or vice versa). These trade-offs typically occur within major building systems – roofs, walls, fenestrations, overhangs, etc. This method offers the designer more flexibility than strictly following the prescribed values for individual elements. The thermal performance of one envelope component such as the roof can fail to meet the prescriptive requirements as long as other components perform better than what is required to make necessary compensation. Trade-offs are permitted only between building envelope components. It is not permitted, for instance, to make trade-offs against improvements in the lighting or HVAC systems. However, this makes using the envelope trade-off option more complicated than the prescriptive method. It is necessary to calculate the surface area of each exterior and semi- exterior surface; all areas are required to be calculated separately for each orientation. Envelope optimization using this method shall be carried out in accordance with Annex C.
- c) *Whole building analysis method* – This method models the thermal, visual, ventilation, and other energy-consuming processes taking place within the building to predict its energy performance. The simulation programme takes into account the building geometry and orientation, building materials, building façade design and characteristics, climate, indoor environmental conditions, occupant activities and schedules, HVAC and lighting system and other parameters to analyze and predict the energy performance of the building. This may be done using computer simulation, which can be accomplished with a variety of computer software tools and in many cases may be the best method for guiding a building project to be energy-efficient. However, this approach does require considerable knowledge of building simulation tools and very close communication between members of the design team. Envelope optimization using this method shall be carried out in accordance with Annex D.

8.3 Renewable Energy Integration in Envelope

8.3.1 Integration of Solar Thermal Technologies

Solar collectors that convert the solar energy directly into usable heat can be aesthetically integrated with the building envelope or they may be mounted on the roof of building.

8.3.2 Integration of Photo-Voltaic Technologies

Building integrated photovoltaic (BIPV) system is the integration of photovoltaic (PV) into the building envelope. The PV modules can be designed and installed to serve the double purpose of building skin replacing conventional building envelope materials and power generation. By avoiding the cost of conventional materials, the incremental cost of photovoltaic is reduced and its life-cycle cost is improved. A complete BIPV system includes the following:

- a) the PV modules (which may be thin-film or crystalline, transparent, semi-transparent, or opaque nature);
- b) a charge controller, to regulate the power into and out of the battery storage bank (in stand-alone systems);
- c) a power storage system, generally comprising utility grid in utility-interactive systems or, a number of batteries in stand-alone systems;
- d) power conversion equipment including an inverter to convert the DC output of PV modules to AC compatible with the utility grid;
- e) backup power supplies such as diesel generators (optional), typically employed in stand-alone systems; and
- f) appropriate support and mounting hardware, wiring, and safety disconnects.

Not only solar photovoltaic technologies but other ways of producing renewable energy may also be integrated in to design, depending upon suitability to geomorphological conditions.

9 MATERIALS

9.1 General

Building materials choices are important in sustainable design because of the extensive network of activities such as extraction, processing and transportation steps required for making a material, and activities involved thereafter till building construction and even thereafter. These activities may pollute the air, soil and water, as well as destroy natural habitats and deplete natural resources.

One of the most effective strategies for minimizing the environmental impacts of material usage is to reuse existing buildings. Rehabilitation of existing building, their shell and non-shell components, not only reduces the volume of solid waste generated and its subsequent diversion to landfills but also the environmental impacts associated with the production, delivery and use or installation of new building materials.

The use of rapidly renewable materials, recycled materials minimizes the adverse impact of natural resource consumption in the manufacture of new building

materials. The use of local materials supports the local economy and reduces the negative impact of transportation.

9.1.1 *Environmental Concerns and Human Health and Safety Aspects related to Building Materials*

Increased demand for building materials creates a major and diversified impact on the environment. Excessive extraction of raw material diminishes non-renewable natural resources very rapidly. Even during some extraction process, waste is generated whose disposal may pose problems. Sometimes extraction processes may also affect the wildlife. Transportation of building materials from one place to another is also a major indirect factor leading to harmful effects. During manufacturing or processing of some materials like plastic, harmful gases are generated, which are dangerous for human health and environment. There are many frequently used building materials like reconstituted wood products, paints, glues, carpet and upholstery, which may release gases, fumes, etc, from the chemical components used, even long after the installation. These volatile organic compounds (VOCs) affect the environment and human health and may cause headaches, dizziness, respiratory problems and even major diseases in human and other living beings.

9.1.2 *Minimizing Green House Gas (GHG) Emission*

Construction sector in the country is a major consumer of energy resulting in the largest share of CO₂ emissions in the atmosphere. Cement, steel and bricks, the largest and bulk consumption items in the construction industry, are contributors of large CO₂ emissions. It is estimated that close to a tonne of CO₂ is emitted during the production of every tonne of cement, resulting in very high GHG emission. Similarly, concrete, which is a very widely used construction material has very high GHG emission. Minimizing the consumption of such conventional materials which may contribute to substantial GHG emission, by using alternative materials and alternative methods and techniques can considerably reduce energy and CO₂ emissions.

9.1.3 *Building Material*

An ideal sustainable building material is not only environment friendly, causes no adverse impact on health of occupants, is readily available, can be reclaimed, can be recycled and is made from renewable raw material, but also uses predominantly renewable energy in its extraction, production and transportation. Practically, this kind of ideal material may not be available, hence when selecting sustainable materials, it may be best to choose materials which fulfill most of these criteria.

9.1.4 *Life Cycle Assessment (LCA) of Building Materials*

LCA of building materials intends to assess the potential environmental impacts at every stage in the life cycle of a material (see Fig. 15) – right from the raw material sourcing, processing, manufacturing and finishing, up to the product installation, maintenance and ultimately reuse/recycle/demolition. It is a tool to determine the

environmental suitability of any building material for a thorough understanding of the environmental impact and the improvement which can be employed at every stage of a material, so as to make a decision for its selection after evaluation of criteria such as embodied energy, performance and durability.

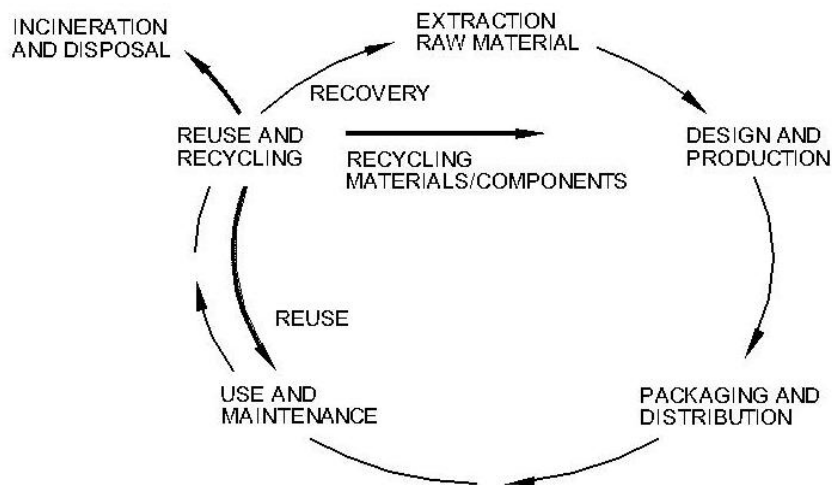

FIG. 15 LIFE CYCLE OF BUILDING MATERIAL

A description of life cycle analysis with respect to various relevant criteria is given below:

- a) *Embodied energy* - Embodied energy is an important factor to be considered in the life cycle assessment of a material. Minimizing embodied energy means minimizing the impact on the environment. In any building construction use of materials with low embodied energy should be considered.

Table 7 gives classification of building materials based on their energy intensity and gives the comparative embodied energy for a few building materials.

Table 7 Classification of Materials Based on Energy Intensity

SI No.	Category of material	Energy intensity (Range) (GJ/t)	Examples
i)	Very High energy	>50	Aluminium, stainless steel, plastic, copper, zinc.
ii)	High energy	5-50	Cement, steel, glass, bitumen, solvents, cardboard, paper and lead.

iii)	Medium energy	1-5	Lime, gypsum plaster board, burnt clay brick, burnt clay brick from improved vertical shaft kiln, soil cement block, aerated block, hollow concrete block, gypsum plaster, concrete block, timber, wood products, particle board, medium density fiber board, cellulose insulation, <i>in-situ concrete</i> .
iv)	Low energy	<1	Sand, aggregate, fly ash, cement stabilized earth block, straw bale, bamboo, stone.

NOTES

1 While comparing embodied energy of building materials, the total quantity by mass of the material times the embodied energy value per unit mass (energy intensity) of the material to be installed for same surface area of the building may be compared.

2 The values given in the table are comparative values, and in case of substantial difference in the transportation component of the materials in question, the same should also be taken into account while calculating the embodied energy.

- b) *Resource reuse and upgradation* – It includes saving a material from disposal and utilizing it by renovating, repairing, restoring, or generally improving the appearance, performance, quality, functionality, or value of a product. Efforts should be made to reuse existing, previously occupied buildings – including the structure, envelope and elements, after removing or replacing the elements which have risk of failure/contamination during construction or occupancy. Upgradation of systems should be done in the areas of energy and water efficiency where the previously installed systems are not environment friendly or efficient.
- c) *Recycled content* – To reduce the demand for virgin materials, effort should be made to use the products with identifiable recycled content, including from those coming from industrial and post-consumer utilization, with a preference for the later.
- d) *Reusable or recyclable* – Effort should be made to select materials that can be easily dismantled and reused or recycled at the end of their useful life. Consider installation techniques which allow easy dismantling and reuse of materials.
- e) *Natural, plentiful* – Effort should be made to use materials which are bio-based and naturally harvested from sustainably managed sources.
- f) *Bio-degradable* – Consider using materials which are bio-degradable so that they can be harmlessly disposed at the end of their life cycle.
- g) *Indigenous or locally available* – Effort should be made to use building materials, components, and systems which are found locally or regionally, saving energy and resources for transportation of materials to the project site, which in turn reduces environmental impacts.
- h) *Rapidly renewable material* – Effort should be made to use materials which replenish substantially faster than traditional extraction demand (for example, timber which can be planted and harvested in less than a 10-year cycle) to reduce the demand for limited/finite resources.
- i) *Materials compliant with clean air and clean water* – Effort should be made to select those materials that emit few or no carcinogens, reproductive toxicants, VOCs, etc. Such materials that enhance the indoor environment quality and

consume less water, do not cause water contamination, pollution as well as help in reducing water consumption should be considered for use.

9.2 Materials and Recommended Sustainable Alternatives

For quality requirements of building materials reference shall be made to **National Building Code of India: Part 5 Building Materials**. General guidelines and considerations for use of different structural and surface finishing materials and with alternatives for helping in sustainable construction, are given under **9.2.1** and **9.2.2**.

9.2.1 Structural Materials

9.2.1.1 Cement concrete

Concrete is a strong, durable material and provides good thermal mass to buildings. However, manufacture of cement used in it is a high energy-intensive process and source of pollution, requiring also, high energy for its transportation due to centralized production. Extraction and mining of aggregates also result in natural habitat destruction or deforestations. Following are the recommended alternatives to conventional concrete:

- a) *Use of pozzolanas and other mineral admixtures for cement replacement in cement concrete and other cement matrix products*
 - 1) *Use of fly ash and slag in cement concrete* – Pozzolanas like fly ash or ground slag may be used to replace certain percentage of ordinary portland cement in cement concrete in accordance with the good practice [11(3)] or cement manufactured by using mineral admixtures like fly ash or ground slag may be used, in accordance with the good practice [11(3)].
 - 2) *Rice husk ash (RHA)* – Rice husk ash, a waste from rice industry, is pozzolanic in nature and may be used for part replacement of cement in accordance with the good practice [11(3)].
 - 3) *Ready mixed concrete (RMC)* – RMC provides opportunity for use of pozzolanas and slag in greater quantities while maintaining strict quality control. Also, there are advantages of RMC over conventional concrete such as reduction noise and dust pollution, apart from better quality control. Preference may be given to use of RMC if the RMC manufacturing plant is nearby. The manufacture, quality control delivery, etc of RMC shall be done in accordance with the good practice [11(4)].
 - 4) *Geopolymer concrete* – It is made with fly ash, ground granulated blastfurnace slag (GGBS), fine aggregates and coarse aggregates and catalytic liquid system (CLS). This concrete uses no Portland cement and utilizes waste products. It has good resistance to chloride penetration and acid attack. However, geopolymer concrete is a future sustainable material option as it is in development stage. It could be designed and developed for a specific use in a project for which specialist literature may be referred.

- 5) *Other cement concrete mix and products/cement matrix products/lime-pozzolana mixtures* – Various cement concrete mix and products, other cement matrix products, lime-pozzolana mixtures, etc, used in buildings having waste based mineral admixtures such as fly ash and slag may be produced or used. The requirements of such products and for their utilization shall be in accordance with accepted standards and good practice [11(5)] which also includes list of accepted standards for mineral admixtures for use in such products as may be applicable.
- b) *Use of recycled aggregate*- Crushed concrete are most common form of recycled aggregates which should be considered for use in concrete. The recycled concrete aggregate should be intended to offer the same level of strength and durability as conventional aggregate from natural resources. In the concrete mix, both virgin aggregate from natural resources and recycled aggregate may be mixed with hydrated cement paste. Such mix may have reduced specific gravity and increased porosity compared to concrete using similar virgin aggregate from natural sources. It is recommended that *recycled aggregate* be batched in a pre-wetted and close-to-saturated surface dry condition. Recycled aggregate may be used in concrete for bulk fills, bank protection, base/fills of drainage structures, pavements, sidewalks, kerbs and gutters, etc. Up to 30 percent of natural crushed coarse aggregates can be replaced by the coarse recycled concrete aggregate, in fresh concrete. This percentage can be increased up to 50 percent for pavements and other areas which are under pure compression. Also refer good practices [11(3)]. For quality requirements for other/artificial aggregates such as cinder as fine aggregate, in line, broken burnt clay bricks as coarse and fine aggregates, artificial light weight aggregates, etc, reference may be made to the accepted standards[11(6)].
- c) *Precast/prefabricated/partially prefabricated concrete elements* – Precast concrete can be used in construction in the form of building elements which are assembled at site and made monolithic by pouring *in-situ* concrete. The products are manufactured by casting concrete in a reusable mould or form which is then cured in a controlled environment, transported to the construction site, and erected at place. Precast concrete elements break the structural span into smaller segments resulting in reduced steel requirement. Precast concrete roofing techniques like plank and joist roofing system, ferrocement roofing channels, precast arch panels, precast waffle units, L-panels are among roofing systems which may have comparatively less embodied energy than conventional RCC roof.
- d) *Use of light weight concrete*
- 1) *Preformed foam concrete* – Preformed foam concrete may be considered for use for the levelling of floors, sprayed onto horizontal surfaces or in hollow cavities as light weight filler.
 - 2) *Ferrocement* – Ferrocement is a thin cement mortar laid over wire mesh (which acts as reinforcement). It uses minimal material (particularly steel) which is reduced compared to conventional RCC.
- e) *Use of light weight aggregates in concrete* – These are usually used in masonry blocks, slabs or floor beam units which are relatively strong. Light

weight blocks help to reduce structural loading of building. These may be foamed blast furnace slag, bloated clay aggregate, sintered fly ash aggregate, cinder aggregate, etc. Mineral insulating aggregate in concrete like light expanded clay, pumice and expanded perlite have the lower moisture absorption coefficient, and are therefore best suited to products used for insulation. Fossil meal and exfoliated vermiculite, perlite or slag due to very high moisture absorption coefficient is preferred for high temperature equipment insulation. If artificial lightweight aggregate is used for making lightweight concrete, the same shall be in accordance with the accepted standard [11(6)].

f) Commonly used masonry concrete blocks:

- 1) *Solid and hollow concrete blocks* – Hollow concrete block masonry uses lesser concrete as compared to solid concrete blocks and provides better thermal insulation due to cavity. Filling of the cores with concrete or concrete with steel reinforcement offers much greater tensile and lateral strength to structures, wherever required.
- 2) *Autoclaved cellular (aerated) concrete blocks* – These are made by mixing fly-ash, lime, cement and gypsum, with foaming agent like aluminium powder which gives them the lightweight and good insulation property. These are lightweight blocks which can be useful to reduce dead load on structure, particularly of high rise buildings.
- 3) *Lightweight concrete blocks* – These blocks are lightweight and manufactured like normal concrete blocks using light weight aggregates.
- 4) *Preformed foam cellular concrete blocks* – These have considerably better thermal insulation properties than normal concrete which is as high as $0.1W/m^2k$ for densities of approximately $650 kg/m^3$.
- 5) *Concrete stone masonry blocks* – Precast concrete stone block masonry which uses recycled stone is a viable option. It can be made with waste stone pieces which could be locally available, and lean cement concrete.

These blocks may be specially useful in places where there is scarcity of good quality clay required for burnt clay brick manufacture. The design mix of concrete blocks can also be done using fly ash as replacement of certain percentage of cement by volume. The concrete blocks shall be in accordance with the accepted standards [11(7)] and masonry construction using these blocks shall be in accordance with good practice [11(8)].

9.2.1.2 Burnt clay bricks and tiles

Bricks are made of clay which is abundant and generally sourced locally. They are durable and provide thermal mass to buildings. They are used for applications such as wall masonry, cladding, flooring and roof tiling. In many cases bricks can improve the indoor climate by regulating and stabilizing moisture levels.

Clay building waste being inert, its disposal has no detrimental effects on the environment. Exceptions are coloured and pigmented brick and ceramic tiles containing heavy metals, fire proof bricks containing soluble chrome and bricks from chimneys which have absorbed large amount of aromatic hydrocarbons during their

life span. These products have to be separated and disposed off by following special precautions.

The burnt clay products have high durability, and these have high potential for their reuse as the energy needed to remove and clean up old material only represents approximately 0.5 percent of the energy required for the manufacture of new bricks and tiles. However, the recovery for reuse of bricks is facilitated if a weak or medium-strength mortar has been used. Ceramic tiles or expanded clay pellets cannot be recycled and have to be usually more down-graded for uses such as for use as fill. Clay tiles and bricks can be broken up and used as fill, and aggregate in concrete in accordance with the good practice [11(3)].

Brick and clay manufacturing is a medium to high energy-intensive and polluting process depending on the firing temperatures and type of kilns used in firing. Preference should be given to locally manufactured bricks and tiles to reduce transportation energy. The vertical shaft brick kiln technology which substantially reduces both the embodied energy and resultant emissions from brick production may be used. The consumption of energy in the kilns can be reduced considerably by the use of bricks with different firing temperatures, in different parts of the building.

The following other types of bricks may also be used as sustainable alternatives:

- 1) *Hollow/perforated bricks* – These types of bricks save the amount of material used and provide better thermal insulation due to the presence of air cavities. These bricks when provided with reinforcements, can be used for structural applications and also in the form of filler blocks to replace concrete in the tensile zone.
- 2) *Low and medium-fired bricks* – Clay bricks which are burnt between 350 °C to 500 °C are low-fired bricks, and bricks burnt at slightly higher temperature like 500 °C to 800 °C are medium-fired bricks. Low-fired bricks are highly absorbent and hence recommended for use in internal walls or inner layer of external cavity walls (where they act as a moisture regulator), etc. The medium-fired bricks although comparatively more durable, may be used in similar applications as above.
- 3) *Burnt clay flyash bricks* – They are lower in embodied energy, provide better thermal property as compared to conventional burnt clay bricks and also utilize flyash, an industrial waste product.
- 4) *Flyash lime bricks* – These are flyash based and use bricks lime as the binder, along with accelerator in required proportion. These have good thermal properties. These are mostly used as masonry units and as fillers in pre-fabricated floor slabs.
- 5) *Red mud burnt bricks* – Red mud is a waste product from aluminium extraction industry. It contains mainly oxides of aluminium, iron and titanium. Red mud and flyash partly replace clay in these bricks. The alumina content gives a nice red tone to the brick. They have high compressive strength and are suitable for all types of construction. The presence of 4 to 5 percent of alkali in red mud also results in better plasticity and better bonding in these bricks.

- 6) *Lato bricks* – These are strong bricks (south western region of India) made of laterite soil mixed with cement or lime, and are moulded under pressure instead of being fired.

For quality requirements of bricks, reference shall be made to the *National Building Code of India: Part 5 Building Materials*.

9.2.1.3 *Traditional efficient building materials*

Each region in the country has developed unique ways of using locally available building material such as stone, timber, bamboo and soil. These building technologies have been developed over time, based on availability of natural materials, climatic considerations and culture. These techniques are not only environment-friendly and energy efficient but are also cost effective as they involve the use of materials which are locally available reducing cost and energy on transportation.

9.2.1.3.1 *Earth construction*

Earthen buildings are easily recyclable, fire resistant, bio-degradable, non-toxic, and have good thermal and sound absorption and moisture regulating properties. This type of construction can easily use onsite earth or locally available material depending on the quality of the earth available. Two main ways of making earthen buildings are ramming where the earth is rammed between shuttering to make walls, and use of earth block (adobe), where the earth is first pressed into blocks and dried before use. Stabilizers such as cement or lime may be added to improve durability. Straw, sawdust and light weight act as reinforcement as well as increase the insulation value. Well mixed, homogeneous earth construction is structural properties. Various options/considerations in this area are:

- a) *Adobe bricks* – These were made earlier with sand and clay mixed with a small proportion of water. Straw and/or grass are included as binder. Mixture is either poured into moulds and allowed to dry or it is pressed into blocks using hydraulic or lever press. Adobe can be made from wide range of soils but require plastering as they are not water-resistant. They have low structural strength but can be easily used for load bearing structures if built between timber/concrete frames.

Stabilized adobe block construction is a new improved system of construction in which stabilization is done by adding fibres (plant or animal fibres), binders (cement, lime, pozzolanas, etc) and sometimes water proofing agents (bitumen, natural and synthetic resins). This kind of construction is suitable for areas with higher rainfall, condensation, flooding, etc. Proportion of soil content in stabilized adobe blocks may be: coarse sand 40-75 percent; clay 10-25 percent; silt, 15-25 percent; and fine gravel, 0-10 percent.

- b) *Adobe pouring construction* – In this system earth is compacted to an extent that the air gaps are eliminated, bulk density is considerably increased and the tendency of development of cracks and to absorb water is reduced.

Adhesion of soil particles with one another increases the mechanical strength and improved water resistant, requiring no surface treatment. The ratio of wall thickness to the wall height should be between 1:8 and 1:12. Symmetrical and geometrical forms are preferred in use of this material.

- c) *Compressed earth blocks (CEB)* – In this type of construction, blocks are manufactured by compacting raw earth using stabilizer such as cement or lime. Compressed earth blocks are generally cuboidal in shape and can be made in solid, hollow or interlocked pattern. Thickness to height ratio of walls constructed with CEB should not be greater than 1:16 and wall thickness not less than 200 mm. This kind of construction can bear load up to three stories. The appropriate particle size distribution of the soil is a critical factor in using these blocks and soil analysis is specially recommended before considering CEB construction. Natural earth plasters with natural additives can also be used on unstabilized walls. These blocks have high compressive strength and provide good thermal mass. CO₂ emission is nil in the production of these blocks if produced by manual operated compression machines and very low in case of other machines.
- d) *Soil based building blocks* – These blocks with appropriate combination of soil cement and flyash (say 5 percent cement:15 percent flyash:80 percent locally available soil) are cost effective and environmentally sustainable material. While in general building construction, soil based blocks may be used as a substitute for bricks, their use should be avoided in the case of isolated load bearing columns, piers and such other heavily loaded structures. These may be made in accordance with the good practice [11(10)].

9.2.1.3.2 Cob walls

Cob walls are a traditional system of wall construction done with soil along with sufficient clay, rough sand, small stones, straw and water. Cob when formed as one mass is called monolithic adobe. Cob is suitable for construction wherever there is sufficient clay in soil/sand (preferably 30 percent). Dug out earth during construction can also be used for construction of cob walls. Unlike adobe brick buildings, cob walls do not require mortar joints, and therefore provide additional strength to the building. Plastering can be done in a 1:3 (lime:sand), for exterior and interior finishes.

Cob wall has good thermal mass properties, is fire resistant; can be integrated with other materials such as straw, light clay, timber frame, adobe, conventional wooden-framed structure; and can be easily moulded into any form.

9.2.1.4 Stone

Stone is a durable and abundant resource. It has much lower embodied energy as compared to brick and concrete as it is natural material and hence requires much less energy in processing. Stone is good in compressive strength but low in tensile strength. It is used as masonry, cladding, and flooring. Stone aggregates are used in concrete mixes. However, mining (quarrying) for stone may cause natural habitat destruction, deforestation and pollution.

Sustainable methodology should be the use of locally available (excavated) and undressed stone to the maximum possible extent subject to compliance to the environmental rules/regulations relating to its mining, etc.

For quality requirements of stones, reference shall be made to *National Building Code of India: Part 5 Building Materials*.

9.2.1.5 Timber

Timber is a building material which is used for structural as well as non-structural applications. It is a material with low embodied energy, is renewable, reusable, versatile, as well as varied in colour, pattern, grain, durability and strength. It is reusable and convertible into other sizes, and has a long life in indoor applications. However, over-harvesting of timber leads to adverse environmental effects such as natural habitat destruction, reduction in oxygen generation, soil erosion and silting of rivers. Due to the such properties of timber, its use may be desirable. However, it is recommended to use timber harvested from sustainably managed forests or social/agro-forestry plantations or reclaimed (salvaged) timber. Secondary species of timber after proper treatment may be used for relevant applications. Timber should be properly seasoned and preservative treated. Timber is prone to fire, moisture ingress and termite and other insect attack. Therefore appropriate treatment is required with least amount of toxic and chemical content, depending upon the end applications. The seasoning and treatment of timber shall be done in accordance with the good practices [11(11)]. For structural timber small dimensional timber from saw milling waste and forestry waste can be utilised for the design of built-up structural components.

Reconstituted wood products are high in embodied energy (due to manufacturing process involved) as well as have toxic formaldehyde contents. However, these products can be considered due to high waste utilization benefits. Prefer using such products that have lower formaldehyde emission.

Use of techniques, like finger jointing which enables utilization of smaller sized timber jointed together through this technique to yield desired larger pieces, may be employed.

For interior applications, use of reconstituted wood or other lignocellulosic panel products made from agricultural or industrial wastes (such as phospho-gypsum, bagasse, cotton stalk, rice-husk, coir fibre, pine needles, sisal fibre and wood residues) should be preferred. For partitioning, panelling, cladding, false-ceiling applications and flooring, the appropriate reconstituted wood or other panel products such as plywood, block boards, particle boards, fibre boards, etc, made from secondary species of wood or plantation timber or from other lignocellulosic ingredients may be used. Reference may be made to accepted standards [11(12)] for compliance and for criteria for making such products eligible to apply for BIS

Eco-Mark Certification in accordance with the provisions laid down in these standards.

9.2.1.6 Plastics

Plastics are highly refined petroleum products. Plastics are materials with very high embodied energy, are non-biodegradable and may release harmful toxic gases during manufacturing processes or if burnt. Their disposal is a major problem yet, due to its light weight and flexibility, plastic has become a widely used material. It has various applications in the exteriors and interiors of buildings. The plastics are majorly used as insulation and as water proofing material [refer **9.2.4.1.1(e)**]. UPVC (unplasticized polyvinyl chloride) window frames are also used for their light weight and thermal properties [refer **9.2.3.2**]. The following recommendations may be considered from sustainability point of view:

- a) Use of plastics should be limited as far as possible or preference given to plastic products made with recycled content or renewable resources.
- b) Natural and renewable insulation materials should be preferred over plastic based insulation material.
- c) If required to be used for interiors flooring, furniture and partitions products made with recyclable plastics should be preferred.

Other options where plastics may be used for appropriate applications, may be:

- 1) *Rice husk plastic wood* – It may be used in door and window frames, furniture and structural supports as it is moisture and termite resistant, highly workable, and meets the requirements of structural timber.
- 2) *Natural fibre composite panels and door shutters* – These are composites of natural fibres in laminate, faced on plastic wood.
- 3) *Fibre-reinforced plastic (FRP)* – These are used to strengthen building components structural members for rehabilitation purposes.

9.2.1.7 Metals

Metals are recyclable, reusable, very durable, light-weight and can easily be moulded into any shape and form. Metals have limited reserves and very high embodied energy due to high consumption of energy to extract metals from its ore. All metals and metal alloys can in principle be recycled and reused. Through recycling of steel, copper, zinc and lead from waste, energy consumption can be reduced by substantially. The metal can be added to new processes in varying proportions, depending upon the end product and its quality requirements.

Steel and aluminium are the two maximum used materials in buildings, followed by brass as (building hardware), zinc and copper (cladding and electrical cables). Steel is used mainly as reinforcement material in concrete or as structural member in steel buildings. Steel building can be dismantled and reused easily unlike concrete. Steel buildings are more earthquake resistant and preferred in earthquake prone areas rather than concrete/masonry buildings. Steel sheets are used for roofing, walls and accessories. Aluminium is used in applications such as, door and window frames,

cladding, and roofing sheets. The following recommendations may be considered from sustainability point of view:

- a) Use salvaged metal sections as far as possible.
- b) Use scrap steel and aluminium for non-structural applications.
- c) Use metals with verified recycled content.

The recycled content of metals varies with the type of furnace used for processing. With electric arc furnace the recycled content can be as high as 90-100 percent, whereas with BOF (basic oxygen furnace) it is about 30 percent. Where feasible, bolted sections should be preferred instead of welded as it helps in reusing the metal sections later; and the sections used should be light-weight, efficient and well designed.

Iron, aluminium, magnesium and titanium can be considered abundant and relatively benign metals, with high recycle potential, even if the environmental consequences of their extraction and production are quite severe. Steel is easy to recover and recycle. Steel with zinc coating or zinc and aluminium alloy increase strength and life of the structure. Virgin chrome, nickel, copper and zinc, however, should be used very sparingly or not at all as natural resources are limited. Copper, nickel and tin can be reclaimed from alloys in which they are the main component. The use of mercury, cadmium and lead should be highly restricted because of their high toxicity. All metals in the long term should be kept within closed cycles, in order to minimize their loss during production or during the life cycle of the building.

9.2.1.8 Bamboo

As an enduring, versatile renewable resource having low embodied energy, bamboo can contribute to sustainable developments and poverty alleviations. It provides healthier environment by sequestration of carbon.

As a building material, it had been abundantly used in the country for traditional huts and hermitages for long besides as scaffolds. With the understanding of its physical and mechanical properties, it has been recognized as an engineering material with scope of designing and constructing moderate houses and other buildings and structures to sustain among others the lateral forces including earthquake forces, etc. Bamboo can be used as structural material in buildings in accordance with *National Building Code of India: Part 6 Structural Design: Section 3B Bamboo and Part 7 Constructional Practices and Safety*. Bamboo can replace reinforced steel in tensile zone in certain applications and within limitations. Bamboo-jute composite panels, bamboo boards, bamboo lathe based partitions, flooring boards are also products which can be used for sustainable constructions.

9.2.1.9 Mortar

Mortar is a material used to bind as well as to fill the gaps between the bricks or blocks used in masonry construction. Mortar is a mixture of sand, a binder such as cement or lime, and water and is applied as a paste which then sets and hardens. The options available may be:

- a) *Lime mortar* – Lime mortar is mixture of sand, slaked lime and water. This kind of lime mortar, sets very slowly. The speed of setting of mortar can be increased by using impure limestones in the kiln, or a pozzolanic material such as calcined clay. Bricks bonded with hydraulic lime can usually be re-used. Lime mortar is easily workable and when hardened is less brittle and rigid than cement mortar, minimizing the problems of cracks. Hydraulic lime mortar is porous, permeable and thus moisture regulating. Lime mortar is produced at lower temperatures than cement and therefore requires less energy resulting in 20 percent less CO₂ emission.
- b) *Cement mortar* – Portland cement mortar is a mixture of Portland cement, with sand and water. Cement mortar is stronger and more impermeable than lime mortar and is therefore more commonly used for construction of load bearing masonry walls. However, manufacturing of cement is one of the major causes of the green house gas emission. Such mortars having as large replacement of Portland cement as possible by alternative but effective materials, is desirable. For this, use of Portland pozzolana cement or Portland slag cement in place of Portland cement in the mortar shall be preferred.
- c) *Mud mortar* – Mud mortar is prepared by simply mixing soil with water until it is in a plastic (workable) state. Once applied, a mud mortar sets quite rapidly on drying without the need for curing. The beneficial characteristics of mud mortars including good bond to compatible surfaces and ease of preparation allow them to be used in a range of applications such as cob walls, adobe blocks in wall construction, masonry, monolithic walls, and even in flat roofs. However, it has low tensile strength and is subject to shrinkage that causes large number of micro-cracks in the mortar reducing its bond strength and the strength of the whole structure. In addition, mud mortars are liable to increased erosion and loss in strength if used in humid or wet conditions. Performance of mud mortars can be improved with various additives such as straw to reduce the shrinkage and cement to increase bond strength (but increases structural cracks which can be compensated for by inserting shrinkage joints).
- d) *Lime sand mortar* – Lime sand mortars are a blend of sand and lime to which cement and water is added on site. Cement helps to give mortar early strength and durability, lime helps to achieve greater strength and elasticity over time, and sand acts as an inexpensive filler.
- e) *Lime pozzolana mortar* – The pozzolana traditionally used in the country is *surkhi* (made by burning clayey soils in a field kiln). Such mortar may be weaker than Portland cement mortar but has better waterproofing properties and has been widely used in dam construction. The use of rice husk pozzolana is also a resource efficient option. Combination of pozzolana containing burnt clay and rice husk can also be used. Flyash can also be used in the preparation of lime-pozzolana mortar. Mixture of lime-fly ash-sand with 5 percent addition of calcined gypsum can lead to good quality mortars.

NOTE – There are other technologies and materials available locally which use no cement and use flyash and binding agents. These options may be and used if performance parameters are met.

For preparation and use of masonry mortars other than mud mortar, reference may be made to good practices [(13)] and for mud mortar to [11(14)].

9.2.1.10 Glass – Refer 9.2.3.1.

9.2.2 Surface Materials

9.2.2.1 Floor and floor coverings

Stones, ceramic tiles, vitrified tiles, bamboo, linoleum, terrazzo, metal tiles, recycled or reclaimed wood and floorings with high recycled content may be some eco-friendly materials if used with due consideration to sustainability. Following are recommendations on use of various floor covering materials which may replace conventional materials:

- a) *Finish concrete flooring* – Concrete floor is highly durable, low in maintenance and can cope with water and chemicals. This flooring can be a resource efficient option where the main slab is finished with topping layer of concrete admixed with colourants and sealers. The finishing layer should be stamped with patterns and grid lines to prevent cracks and for improved appearance. Water dispersed acrylic sealers having lower VOC may also be used.
- b) *Resilient flooring (bamboo and linoleum flooring)* – Bamboo is a natural, renewable, hard wearing and economical option for flooring. Bamboo flooring can be of solid bamboo (made with only bamboo) or bamboo mat board with or without wood veneers. Linoleum flooring is made with reusable and natural occurring material like cork, linseed oil, wooden flour and pine resin. Both the flooring material require frequent maintenance and can cause indoor pollution if they are VCT (vinyl composition tile) or polyvinyl tile sheet based (release of toxic materials in their production). Refer accepted standard and good practices [11(15)] for linoleum flooring.
- c) *Terrazzo in-situ flooring and tiles* – These tiles may contain up to 60 percent recycled content (crushed stones) mixed with cement. It is a low embodied energy, inert and highly durable and low maintenance flooring. Adhesive used for tiles laying should be of low VOC, non-toxic in nature. Cement mortars with acrylic additives are the better options for adhesive. Refer accepted standards and good practices [11(16)].
- d) *Ceramic/vitrified tiles* – These are durable, have low maintenance requirement and can have high recycled content (clay mixed with up to 95 percent recycled content like recycled glass and crushed stone and feldspar), and are water resistant and may also be recyclable depending upon the pigments added. Ceramic and vitrified tiles have higher embodied energy as compared to terrazzo tiles as there is firing process involved in their manufacturing. Also, these tiles may have pigments (metal oxides), many of which are environmental pollutants, hence rules for proper disposal need to be followed. Low VOC and non-toxic option for adhesive for laying these tiles should be used. Cement mortar with acrylic additives is most suitable and safer option. Refer accepted standard [11(17)].
- e) *Wooden flooring* – Timber or reconstituted panel products used for manufacture of wooden flooring shall comply with the **9.2.1.5**. For protective

coating of these products water dispersed urethanes having low VOC (than solvent based), and not having toxic urea formaldehyde should be used. Prefer using acid cured varnishes and low VOC adhesive. Finishing of these materials (laminates, veneer or coatings) shall also be of low VOC.

- f) *Stones* – Limestone, marbles, granites are some common stones that last longer than the manufactured tiles. Refer **9.2.1.4** for stone properties and sustainable alternative.

9.2.2.3 External and internal wall finishes

Selection of materials for external wall finishing is important as it affects the thermal and acoustic insulation of the building and materials for internal wall have effect on indoor air quality (IAQ). Following are recommendations from sustainability point of view:

- a) *Plaster* – Plaster not only acts as a protective covering over walls and provide finishing, but also plays important role in indoor environmental quality of building. There are several alternatives in plaster available, depending on the surface to be plastered, climate of the place, elasticity, etc. The usual binders are lime, cement and gypsum or the mixtures of these substances. Fibre, mineral fibre, perlite, hacked straw, or even hair from cow, pig and horse are sometimes added for better binding, elasticity and /or insulation. Pigments if added are generally metallic oxides, which should be fine grained and calciferous. For external plastering or plastering in rooms such as bathrooms, water proofing agents are sometimes added to plaster. The grain size of sand in plaster shall depend on the surface quality required and layers of plasters to be used. The raw material availability of the different component of plaster is generally good. Lime and gypsum based products have good moisture regulating properties. Waste of Lime and cement based plaster, being inert can be used as fill. Pure lime plaster can be ground up and used to improve the soil. Dumping sulphur and gypsum waste can lead to sulphur pollution which can be reduced by adding lime. Features of various plasters having effect on sustainability are as follows:

- 1) *Lime plaster* – It is a very old and sustainable method of plastering which require higher degree of skill for good quality work. It is composed of lime, sand and water and is also suitable for use with clayey soils (Lime: soil should be between 1:10 and 1:5). In the making of lime-pozzolana plaster, *surkhi* (made by grounding waste bricks to fine powder), fly ash or rice husk ash can be used in lime mortar in the ratio of 1:1:1 (1 Lime putty: 1 *surkhi/flyash/rice husk ash*: 1 sand). Lime can also be obtained from fertilizer industry (as on industrial waste). Lime plasters have low VOC and have approx 25 to 28 percent lower carbon dioxide emissions, have lower embodied energy and can contain 50 to 65 percent post-industrial use recycled content. It has wide applicability in restoration of heritage buildings. It is most suitable for internal use but can also be used externally. However, for external use it should be protected against driving rain and continuous dampness, otherwise it may get damaged due to its high porosity. For

external use, lime to sand ratio of 1:3 should be used. Lime plaster helps the walls to retain their moisture regulatory properties.

- 2) *Cement plaster* – This is mostly used as an external plaster and can be used on brick masonry, solid concrete walls, concrete block masonry, stone masonry, etc. For internal plaster, the proportions can be 1:6 (cement:sand), whereas for external use they may vary between 1:3 to 1:4 (depending upon the surface to be plastered and the climatic conditions). For application of cement plaster, reference may be made to good practice [11(18)].
 - 3) *Cement-lime plaster* – This plaster is used quite a lot externally. It is somewhat stronger than lime plaster and more elastic than pure cement plaster. In cement and cement-plaster, 30 to 50 percent of the binder is cement. For applications of cement-lime plaster, reference may be made to good practice [11(18)].
 - 4) *Gypsum plasters* – It is a dry mixture of gypsum and mineral fillers. Gypsum plastering is mainly for internal use especially as a moisture regulating layer, usually having a mix of one part of gypsum and two parts sand. This sets in 10 to 30 minutes. Lime can be added to make the gypsum plaster usable for longer time. Gypsum is a natural mineral, has quality to absorb pollutant and can also be easily percent recycled completely. This plaster has good compressive strength, and thermal, acoustic and fire resistant properties. Gypsum can be obtained from either natural resources or it can be obtained as industrial by-product or as a product with recycled content. For materials for plaster, requirements and application, reference may be made to accepted standards and good practices [11(19)].
 - 5) *Clay plaster* – Clay plaster is a natural, breathable material which is created by composing rocks and minerals, mixed with sand and water to create a workable mix for plastering. It is bio-degradable, absorbs odours, has good sound and thermal insulation properties, is fire resistant and has good temperature regulation properties. Plastering with clay is a quicker method than with traditional gypsum plastering. Long drying time means that it is workable for longer period. However, it is not as strong as other plasters in shear and compressive strength.
 - 6) *Sulphur plaster* – This can be produced by melting sulphur at temperature from 120 °C to 150 °C. Sand, wood flour or the equivalent can be added. It has waterproofing properties but cannot be used over materials with high lime content.
- b) *Mineral and fibre based sheeting/boards* – There are three main types of mineral based sheeting: cement based, calcium silicate based and gypsum based. Raw materials for all the three are abundant. Apart from the binder, they contain fibrous reinforcement. When they are mounted, the joints should be filled with filling material based on plastic binders, mainly PVAC glue or acrylate glue. Production of these sheets is relatively low in pollution. Calcium silicate and gypsum products are also good moisture regulators. Features of such boards having effect of sustainability are as follows:

- 1) *Fibre cement sheets/boards* – These are suitable for all modern and conventional constructions for both internal and external uses as they have high resistance against moisture, fire and termite. It may contain up to 35 percent fly ash and 5 percent recycled pulp and other recycled content, has a long life span, requires little maintenance and is economical. High embodied energy in its creation is compensated by the use of fly ash and recyclable waste. For requirements for some of these sheets reference may be made to accepted standards [11(20)].
 - 2) *Calcium silicate sheet* – These can be used as both internal and external cladding. The sheeting is produced with up to 92 percent by mass of quartz mixed with lime and cellulose fibre. Vermiculite can be used as aggregate. Calcium silicate products can be crushed and recycled as aggregate in concrete. If it is finely ground it can be used in mortars and plaster. The waste is inert and can be used as fill.
 - 3) *Gypsum plaster board* – These boards are manufactured from 95 percent gypsum with possible addition of fiberglass reinforcement (about 0.1 percent by mass). The substances such as calcium lignosulphate, ammonium sulphate and an organic retardant may also be added to a total of about 1 percent by mass. Pure gypsum sheeting is not too strong; hence, some lime and a large percentage of wood shavings are added to increase strength. The sheeting products are used mainly for internal cladding, and may be covered by wall papers or thin fiberglass woven sheeting for painting. Pure gypsum plaster board is too weak to be dismantled and re-used but it can be broken and recycled and used as 5-15 percent of raw material. However, since gypsum industry is very centralized, it makes it uneconomical to recycle. Refer **9.2.2.3(a)(4)** for properties of gypsum plaster. For requirement and use of different gypsum plaster boards and material for their manufacture, reference may be made to accepted standards and good practices [11(21)].
- c) *Grit wash* – This finish uses waste stone pieces and aggregates like marbles, granites, stones mixed with cement, etc. This is a permanent finish requiring less maintenance.
- d) *Paints and coating* – Generally paints and coatings contain large quantity of VOC and create pollution indoors as well as outdoors (due to release of volatiles by oxidation of both solvent and water based paints). Water based acrylic paints are better option over solvent based oil paints because of durability and lower toxic release. Paints made from natural raw ingredients such as milk protein, minerals, bee wax, natural wax, lime, chalk, talcum, earth and clay pigments and plant oils and resins, should be preferred as they have little to no smell and low VOCs.
- e) *Timber* – Refer **9.2.1.5**.
- f) *Stone cladding* – Stones can also be used as external wall finishes. However, stone fixing has to be carefully considered for high seismic zone and high rises.

- g) *Metal composite panels (MCP)* - These are formed by bonding two metal skins to a highly engineered plastic core placed between them, creating a sandwich panel. The bonding process occurs under very precise conditions of temperature, pressure and tension resulting in a metal/plastic composite sheet. MCP is used for cladding of building exteriors, entryways, canopies, soffits and facias. Metal skins may be of aluminum, zinc, copper, stainless steel, and titanium. MCPs can be finished in different colours. MCPs are flexible, durable, light weight and easy to install and maintain, fire resistant, weather proof and flexible with low emissivity and high reflectance.

MCPs having high percentage of recycled content and made out of reused plastic core should be preferred.

- h) *Wallpapers* – Wall papers are for internal use. Wall papers like grass cloth wall paper, bamboo wall paper and jute wall paper are some eco-friendly biodegradable wall papers. The grass cloth wallpaper is hand-made from woven natural grasses and therefore is sustainable and manufactured from renewable resources.

9.2.3 Building Fenestration and Detailing

9.2.3.1 Glazing

Glass is a high embodied energy mineral material. Its usage is in skylights, windows, glazing systems, flooring, infill panels for doors. Glass helps to get in natural daylight to interior spaces and provides views. Glazing if not chosen and positioned in a building properly may lead to lot of heat ingress/egress.

Glass shall be selected with high recycled content and shall be so sized as to minimize wastages. Use of glazing in fenestration shall be in accordance with **8.1.3**.

9.2.3.2 Door-window frame

Frames made of stone, wood, steel, aluminium and UPVC are generally used for building construction. Use of stone frame should be preferred in the area where they are locally available as they provide an economical, durable, and termite proof frame. Wooden frames provide better insulation than metal frames. Metal frame although recommended for its durability, high recyclability, light weight and for larger spans, has high heat conductivity. Metal frames are required to be detailed with thermal break (low conductive material) to reduce their conductivity. Frames of plastic and aluminium can be made of profiles filled with foamed insulation of polyurethane to offset high heat conductivity. Composite products are now being available which use either aluminium with UPVC or timber with aluminium, where timber is the insulating material. Inferior quality timber can be used in that case, as the outer layer of aluminium provides weather protection to the same.

Plastic windows are usually made of unplasticized polyvinyl chloride (UPVC) stabilized by cadmium, lead and tin compounds and added colour pigments. All these products have very limited reserves, and cause high level of pollution during processing.

The manufacture of an aluminium and UPVC door and window frame uses very high energy input than a timber door and window frame window. Both UPVC and aluminium windows can be reused if they are initially installed for easy dismantling. Pure aluminium frames can be recycled. Special precautions should be taken to dispose off wastes which contain cadmium, lead or tin. Considerations given in **9.2.1.6** may be followed.

Defective doors of solid timber can usually be recycled or composted but laminated products should be disposed off with special precautions or recycled in incinerators that filter the fume. Considerations given in **9.2.1.5** may be followed for selection of timber for frames. For requirements of wooden frames including such frames eligible for BIS Certification for Eco-Marking, reference may be made to accepted standard [11(22)]. Depending upon the availability or otherwise of various alternatives and their suitability for sustainable considerations, use of precast reinforced concrete door and window frames may be considered as they are highly durable and also eligible for eco marking; for quality requirements of this frame, reference may be made to accepted standard [11(23)].

9.2.4 Climatic Materials

Climatic changes is the prime factor affecting longevity of the building, maintenance of a safe and eco-friendly environment and durability of building materials. There are several historic buildings which have existed for centuries due to the reason that they were built with durable materials to withstand different climatic conditions of the places in which these were built. These materials can be used for (a) Climate responsive designs as well as for (b) reducing the harmful impact on environment.

9.2.4.1 Thermal insulation materials

The thermal insulation of walls and roof shall be done in accordance with **8.1.1** and **8.1.2**. Thermal insulation materials are used for making a building resistant to heat ingress and egress. A thermal insulator is a poor conductor of heat and has low thermal conductivity. Thermal resistance, thermal conductivity, thermal transmittance, stability, density of materials, long life, fire resistance, lack of odour, low chemical activity, ability to cope with moisture and good thermal resistance are some factors which have to be considered in selecting materials for thermal insulation.

9.2.4.1.1 Types of thermal insulation materials

Insulation materials may be divided into organic and non-organic groups (mineral fibres, glass wool, perlites) according to their raw materials. Organic materials can be subdivided into more environmental friendly for example natural materials (cork, cotton and wool) and less environment friendly for example synthetic materials (polyurethane rigid foam and polystyrene). Some thermal insulation material may be reflective and some high in embodied energy, which may get offset by saving in the operational energy of the building over their life span.

- a) *Mineral wool* – Mineral wool products are light and have extremely good thermal insulation values. When used as insulation both glass and rock wool need a barrier of suitable material sheeting partly to avoid dust and partly because the material cannot regulate moisture as required. Exposure to mineral wool fibres may cause skin problems, itching, eye damage and respiratory irritation. Raw materials are abundant for the main constituents of glass wool and rock wool. The production of glass wool occurs in relatively closed processes where emissions are little and limited to formaldehyde and dust. Large amounts of phenol, ammonia, formaldehyde and dust are released during the production of rock wool, and large amounts of wastes are produced. For requirements of bonded mineral wool, reference may be made to accepted standard [11(24)].
- 1) *Glass wool* – Made from silica sand, limestone, boron, recycled glass (approximately 70 percent), phenol formaldehyde resin or acrylic resin, it is a lightweight and fire resistant insulation material commonly used for duct and wall insulation. Glass wool is a high embodied energy product as glass is melted at higher temperature to make the fibre. Glass wool is easily recyclable and possesses good acoustic insulation properties.
 - 2) *Rock wool* – It is a light weight high embodied energy and fire resistant product, made from natural rock basalt primarily under high heat. It is denser than glass wool so *R* value is higher than glass wool. Rock wool may contain 10 percent recycled content in the form of building waste and 15 percent recycled content from waste from industry (slag from the steel production process). For requirements, reference may be made to accepted standard [11(23)].
 - 3) *Cotton* – This is a rapidly renewable product made from both natural fibres as well as industrial waste from recycled cotton textiles. Cotton is also a good sound insulator, requires little energy to manufacture as well as is non-toxic. Waste cotton, a high water absorbing material should be protected by moisture/vapour barrier.
 - 4) *Natural wool* – It is made with recyclable and renewable source and is non-toxic and bio-degradable. It does not contain any synthetic fibres but has a disadvantage that it absorbs VOC.
- b) *Cellulose fibres* – These can have very high recycled content and can be made from waste papers (about 90 percent recycled papers) or pulverized pulp and are cost-effective. They can also be made from different types of cellulosic materials like card boards, waste papers, old newspapers, cotton, straw, saw dust and hemp. These fibres have very low embodied energy, but they need to be treated for fire retardance (such as by boric acid). This product may be reused and recycled but should not be incinerated.
- c) *Plastic* – Many plastics have good water-proofing and high thermal insulation properties (when produced as foam). As a sealant, plastic can take many forms such as paint, sheeting, paper, sealing strips and mastics. The materials are foamed up using chlorofluorocarbons and carbon dioxide, and fire retardants and stabilizers are added. It is recommended to use products which do not use CFCs or HCFCs as blowing agents during manufacturing.

Depending upon how the materials are built in, polystyrene can emit extra monomers of styrene while polyurethane can release small amounts or unreacted isocyanates and amines. Ashes from the furnaces and plastic waste which is not recycled needs to be disposed off safely to prevent seepage into the ground water or soil. Properties of polystyrene are as follows:

- 1) *Extruded polystyrene* – This material has very high *R*-value per unit thickness, good moisture resistance, and high compressive strength and is light in weight. It is commonly used in wall and roof insulation.
 - 2) *Expanded polystyrene* – It is a light weight and has high *R*-value, but it has low compressive strength and is not moisture resistant.
- d) *Autoclaved aerated (cellular) concrete blocks* – Refer **9.2.1.1(g)(2)**.
 - e) *Preformed foam cellular concrete blocks* – Refer **9.2.1.1(g)(4)**. These have better water resistance.
 - f) *Hollow concrete block* – Refer **9.2.1.1(g)(1)**.
 - g) *Reflective Insulation materials* – These comprise highly reflective materials like aluminium foil. It may retard the heat transfer up to 97 percent. It is very effective in warmer climates, requires less area, acts as a vapour barrier also, and is non- toxic. However, it has less compressive strength and requires some backing support.
 - h) *Perlite and pumice products* – Perlite is a natural glass of volcanic origin. It is pulverized and expanded in rotating kilns at about 900 to 1200 °C, which increases it's volume from five to twenty times. It is used either as loose fill insulation or as aggregates in mortar and light weight concrete blocks. Perlite absorbs water, hence moisture preventive materials like bitumen or silicon are sometimes added. It can be used for thermal insulation of buildings, refrigerating rooms and high temperature insulations.
 - i) *Vermiculite products* – Vermiculite is formed through the disintegration of mica, which liberates lime and takes up water. When vermiculite is heated to 800 to 1 100 °C, it swells to become a light porous mass which can be used as an independent loose insulation or as an aggregate in a lightweight concrete in the proportion of 6:1 (vermiculite to cement). Prefabricated slabs can be made in varying thickness from 15 mm to 100 mm using this material. Vermiculite is useful for high temperature areas and equipment. It easily absorbs large amount of moisture, even more than untreated perlite. As normal wall insulation, it has a tendency to settle, hence needs to be compressed substantially after filling into the wall cavity.
 - j) *Saw dust and wood shavings* – Saw dust and wood shavings which are wastes from timber industry or carpentry can be used for thermal insulation in walls or ceilings. Saw dust has hygroscopic property due to which it easily absorbs moisture, and then releases it in air and therefore is moisture regulating. Saw dust and wood shavings are chemically inert, non-toxic. However they are not fire resistant, and the same can be improved by adding pulverized clay.
 - k) *Traditional techniques* – Following vernacular techniques have generally been used effectively for thermal insulation of building in the country:

- 1) *Straw-bale insulation* – Straw bale walls (bales of straw commonly of wheat, rice, rye and oats which are agricultural wastes after harvesting) have good sound insulation properties. These should be packed tightly for improving fire resistance. Straw bale is biodegradable, low embodied energy, non-toxic, easily available, cost effective and rapidly renewable product. These walls are porous in nature hence exposed walls require protection from rain in the form of plaster (generally lime plaster) and deep eaves/verandas.
- 2) *Inverted earthen pot insulation* – Shading the roof top with inverted earthen pot is an easy and cost effective method to reduce solar gain. In this method roof is covered by inverted earthen pots, the top of earthen pot can be covered with a layer of earth or lime mortar finish or can be left uncovered. By virtue of air trapped within them they provide good insulation. Earthen pots painted with white paints further reduce the heat load. Pots made with earth are recyclable and locally/regionally available.
- 3) *Brick bat coba* – This system involves laying mortar with broken brick (which may be waste brick pieces) as aggregates and ground brick with lime or cement as binding matrix. A thick mass of brick bats provide the thermal insulation for roof of the building.
 - a. *Mud phuska* – For this, good quality earth suitable for brick making not containing excessive clay or sand, free from stones, *kankar*, vegetable matter and other foreign matter should be used. In this system a layer of puddled mud is mixed with grass straw applied on a sand-bitumen waterproofing layer which is then consolidated and plastered with cow-dung mortar. Tile bricks are laid flat on plastered surface and the joints are grouted with cement mortar. All materials are readily available, economical and non-toxic. Laying of mud phuska shall be done in accordance with the good practice [11(26)].
 - l) *Broken Ceramic mosaic tiles* – Broken ceramic tiles can be used as a cost effective external roof finish to reflect the incident solar radiation. Broken ceramic light-coloured tiles reflect heat off the surface because of high solar reflectivity and effectively utilize the waste ceramic tiles.
 - m) *Cavity wall insulation* – Cavity wall consists of two layers of masonry separated by a hollow space that work as a thermal insulation as well as provide better sound insulation. Cavity wall made with fly ash concrete blocks or blocks with high recycled content or internal wall with under burnt clay bricks makes it more environmental friendly. Hollow space between the two walls can be filled with the insulation materials. Rat trap bond is a cavity wall construction technique with added advantage of economy in brick use (of about 25 percent). However, these walls occupy more floor area.

9.2.4.1.2 Covering or finishing materials for thermal insulation

These are used to protect and help to elongate the life and usefulness of the insulation from weather, water vapour condensation, chemical attack and sometimes even from fire. Additionally, appearance coverings are utilized to provide the desired aesthetics. These may include:

- a) *Weather Barriers* – These should be installed on the outer surface of thermal insulation to protect the insulation from the weather such as rain, snow, sleet, dew, wind, solar radiation, atmospheric contamination and mechanical damage. Metals, plastics, paints and coatings and roofing felt are few weather barriers.
- b) *Vapour retarders* – These are materials which retard the passage of moisture or vapour into the insulation. Laminated foil-scrim membranes and metal and plastic sheets are vapour retarders.

9.2.4.2 *Moisture and air regulating materials*

Moisture and air regulation in sustainable building is essential to get better indoor environmental quality as well as to protect building and building components from damage. Insulation and other components aimed at controlling seepage of moisture and air to and from building shall be included in the building envelope design. Common air sealing materials include caulks, expanding foams, weather-stripping of doors and windows, gaskets, door sweeps. Another environment friendly technique is to use high recyclable moisture regulating materials like adobe brick and mud construction.

9.2.4.3 *Water proofing materials*

Water proofing materials resist liquid water passing through, but may allow water vapour to pass through. They can be categorized on the basis of application (cold applied or injection type) or on the basis of their types or state (layer type or fluid type).

- a) *Cement based waterproofing products* – These are suitable for both negative and positive water pressures. They contain no solvent. They are however low on elasticity and prone to cracking.
- b) *Plastic-Polymer products* – Plastics polymers have good water proofing properties and have been successfully used due to their light weight, elasticity and non-porous nature. However, there are major limitations from sustainability point of view using plastic products (refer 9.2.1.6). Some examples are coal-tar, bitumen, ethylene propylene diene monomer (EPDM), polyurethane and PVC, which are briefly described below:
 - 1) *Polymer modified bitumen* – These are available as hot-applied fluid products and as sheet membranes.
 - 2) *Polyurethanes/urethane membranes* – These are typically fluid-applied and remain elastomeric (flexible) throughout their useful life. This group of waterproofing membrane materials is commonly referred to as fluid-applied elastomers.
 - 3) *Thermoplastics (PVC) waterproofing membranes* – These are available in sheet forms are typically applied with heat-welded seams.
 - 4) *Asphaltic membranes* – These are typically consist of emulsified (liquid) asphalt and reinforcing fabric, fiberglass or organic, applied in layers.

- c) *Brick bat coba* – It provides water-proofing up to some extent. Brick bats coba may be made cost effective by using waste generated during construction or demolition. It works more efficiently if used in combination with other water proofing material. The disadvantages of using brick bat coba are increase in dead load on slab as well as thickness as compared to other water proofing materials. Also see 9.2.4.1.1(k)(3)
- d) *Bentonite clay* – Bentonite is sedimentary clay composed of weathered and aged volcanic ash. It has the capacity of quickly absorbing large amounts of water and swelling to many times in volume. When the surroundings dry out again, the clay releases its moisture. It is useful as an absorbent waterproof membrane on foundations and foundation walls made of brick and concrete. It is available in rigid, flexible and granular form.
- e) *Other waterproofing membrane materials* – These may be materials such as butyl rubber, crystalline and cementations products. Besides, there are some eco-friendly organo silicone products based on nano-technologies which also work as waterproofing materials.

9.3 Construction Phase Material Storage and Handling

It is essential for construction industry to have proper material handling and storage to provide a continuous flow of materials and components and ensure that materials are available when needed and to avoid wastage. For storage and withdrawal of construction materials from storage places, first in first out policy should be followed. Care has to be taken in storing moisture sensitive construction phase materials like cement, plaster of Paris (POP), gypsum board, wood and other lignocellulosic materials based products, as well as steel components/materials which may get corroded in the presence of moisture. Inflammable, volatile materials may need proper segregated storage. There may be some materials or components which require to be stored/stacked in a manner so as to avoid undue stress over them and ensuring safety of the personnel. For guidance on proper stacking and storage of building materials, a reference may be made to good practices [11(27)].

9.3.1 Handling of Material and Equipments

Handling materials involves diverse operations of crane, truck and manual handling. The efficient handling and storing of materials is vital considering continuous flow through the workplace, and availability. Improper handling may cause severe damages. The workers should be aware of the potentiality of the injuries and hazards due to unsafe or improper handling. During mechanical shifting of materials, one should avoid overloading the equipment.

To reduce potential accidents associated with workplace equipment, employees need to be trained about the proper use and limitations of the equipments. The operating manuals of major handling equipments for example conveyors, cranes, slings and industrial trucks should be referred before using these equipments. Periodic inspection and checking of handling equipments should be carried out by the authorized persons only.

9.4 Construction Waste Management - Refer 12.7 for details.

10 WATER AND WASTE MANAGEMENT

10.1 General

10.1.1 The country has been well endowed with large freshwater reserves. However, with the increasing population, industrial activity and pollution, surface and groundwater has been overexploited during the past few decades. As a result, the country is faced with immense water scarcity. Growth of the country's economy is driving increased water usage across sectors. Waste water generation is increasing significantly and in the absence of proper measures for treatment and management, the existing freshwater reserves get polluted. Further, increased urbanization is driving an increase in per capita water consumption in towns and cities. Urbanization is also resulting in change in consumption patterns and increased demand for water-intensive agricultural crops and industrial products.

10.1.2 Sustainable approach to water and waste management requires planning and design of building functions to integrate issues of water and waste management system at the early stages of project evolution, their management during construction activity and subsequently during occupancy and use of building. At the scale of building complex or at township level, the opportunities for water efficiency and waste management are large. Sustainable approach for water and waste management should, therefore, include such management aspects in respect of external development and landscaping (see 7.3). The sustainable approach should finally adopt an integrated approach to water supply, water waste and solid waste management aimed to create built facilities with zero anthropogenic waste design solution. Following are the broad aspects for achieving sustainable water and waste management:

- a) *Conceptualization, planning and design stage* – Water is essential to create livable neighbourhoods and public spaces. The function of a water supply system is to provide water from a source identified through considered selection, treat the same to render it suitable for its intended use, and deliver it to the user at the time and in the quantity desired. Major considerations during planning and design include yield and quality of raw water sources; topography, geology, population density of service areas; intended uses of water; and treatment of waste water. Since these considerations may vary from project to project, all water and waste management system solutions are unique.

Planning and design of water and waste management system needs a holistic approach. The system should integrate functions, water supply systems, waste water system (including grey water use), storm water management (including rain water harvesting) and solid waste management and waste to energy systems. The complexity of holistic design process requires coordinated decision-making process.

- b) *Construction stage* – Objective of construction stage is to create the built facility. The concerns of efficient water use and waste have a potential to be ignored. It is essential to establish systems for water and waste management so that the project teams monitor water consumption, control wastes and

dispose off in an environmentally appropriate manner. There is a scope for selection of materials and technologies, which are water efficient. Value engineering of material and technology selection should be undertaken so that the solutions are appropriate to the project peculiarities as well as environmental constraints. Construction including in environmentally sensitive sites, necessitates compliance to legal and statutory requirements for water and waste management.

- c) *Performance during use and corrective action* – Building projects are planned, designed and executed in accordance with the anticipated functional use. However, it is reasonable to expect some variance during use. Building use is a dynamic process and functional use is constantly evolving during life of a building. Also, engineering system designs are optimum solutions based on assumptions, which can only be validated during actual use. Design of systems should be done within a considered tolerance of functional use. The performance of water consumption should be monitored during use and compared with the benchmarks (industry specific, building specific or established standards) given in the Code and corrective actions undertaken. In this respect, it is important to design systems that facilitate monitoring. Appropriate metering and corrective improvements should be integrated in the system design detailing. It may be desirable to design water system taking functional homogeneity into account and facilitate function specific corrections.

10. 2 Planning and Design of Water Management System

10.2.1 *Planning and Design of Water Supply System*

Planning and design process begins with use analysis for demand assessment, identification of project constraints and water sourcing. Inputs on these parameters are critical design brief contents. Hot water systems are energy intensive building component. Opportunities for waste recovery, temperature setting and selection of technologies that use clean fuels need to be included in the planning and design approach for hot water systems. While the systems may be designed efficiently, the strategies for water efficiency and conservation need to be built into the system design. Finally, system components need to be integrated as part of sustainable planning and design approach. Fig. 16 gives a typical scheme showing general components of water management system. This shall also incorporate fire water requirements.

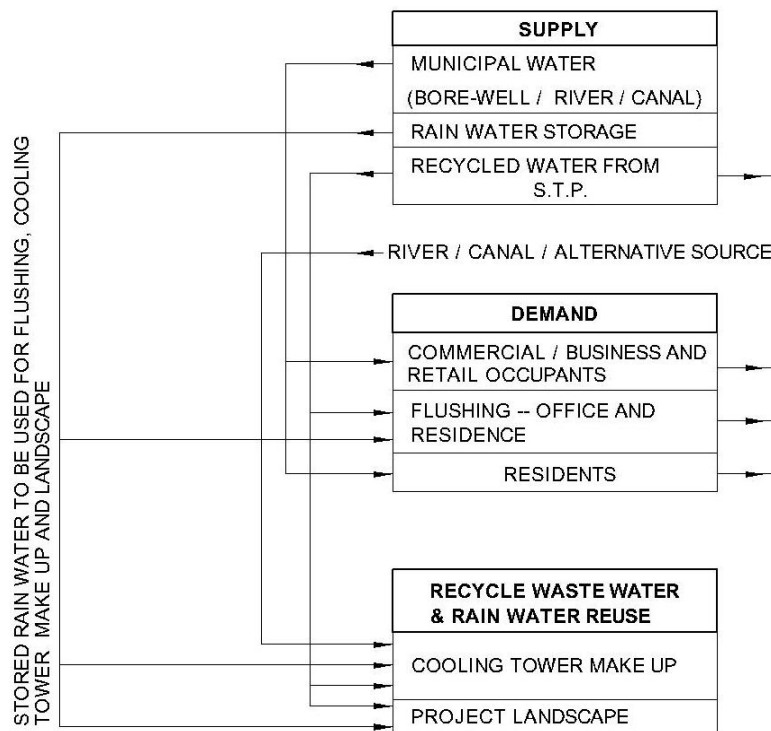

FIG. 16 TYPICAL SCHEME SHOWING GENERAL COMPONENTS OF WATER MANAGEMENT SYSTEM

A reasonably accurate estimate considering a calendar year long demand-supply assessment including demand fluctuations of the amount of water that should be supplied, is needed early in the planning stage of project development. The average daily demand is specially important since it may be used to assess the ability of available sources to meet continuing demands and to size raw water storage facilities that may be required to meet sustained demands during dry periods. Later, during the actual design process, the peak demand is required to properly size pumps and pipelines, estimate pressure losses, and determine water storage requirements so that it may be planned to store sufficient water and cater for daily water demand. Uses of water include agricultural, industrial, household, recreational and environmental activities. Almost all of these human uses require fresh water.

10.2.1.1 Availability of water

The water availability and the associated features and constraints are as follows:

- a) *Surface water* – Surface water is water in river, lake or fresh water wetland. Surface water is naturally replenished by precipitation and naturally lost through discharge to the oceans, evaporation, evapo-transpiration and sub-surface seepage. Although the only natural input to any surface water system is precipitation within its watershed, the total quantity of water in that system at any given time is also dependent on many other factors. These factors include storage capacity in lakes, wetlands and artificial reservoirs, the permeability of the soil beneath these storage bodies, the runoff

characteristics of the land in the watershed, the timing of the precipitation and local evaporation rates. All these factors also affect the proportions of water lost.

Human activities can have a large impact on these factors. These often include increase in storage capacity by constructing reservoirs and decrease by draining wetlands, increase in runoff quantities and velocities by paving areas and channelizing stream flow. Also surface water may be lost (for example, become unusable) through pollution.

The total quantity of water available at any given time is an important consideration. Some users have an intermittent need for water. For example, many farms require large quantities of water in the spring, and very less or no water in the winter. To supply such a farm with water, a surface water system may require a large storage capacity to collect water throughout the year and release it in a short period of time. Other users have a continuous need for water, such as a power plant that requires water for cooling. To supply to such a power plant with water, a surface water system needs enough storage capacity to fill in for use later when average stream flow is below the power plant's need. However, over a long term the average rate of precipitation within a watershed is the upper bound for average consumption of natural surface water from that watershed.

Natural surface water can be augmented by importing surface water from another watershed through a canal or pipeline. It can also be artificially augmented from any of the other sources; however in practice the quantities of such water are negligible.

- b) *Under river flow* – Throughout the course of the river, the total volume of water transported downstream will often be a combination of the visible free water flow together with a substantial contribution flowing through sub-surface rocks and gravels that underlie the river and its floodplain called the hyporheic zone. For many rivers in large valleys, this unseen component of flow may greatly exceed the visible flow. The hyporheic zone often forms a dynamic interface between surface water and ground water, receiving water from the ground water when aquifers are fully charged and contributing water to ground water when ground waters are depleted.
- c) *Ground water* - Sub-surface water, or groundwater, is fresh water located in the pore space of soil and rocks. It is also water that is flowing within aquifers below the water table. Sometimes it is useful to make a distinction between sub-surface water that is closely associated with surface water and deep sub-surface water in an aquifer.

Sub-surface water can be understood in the same terms as surface water: that is, in terms of inputs, outputs and storage. The critical difference is that due to its slow rate of turnover, sub-surface water storage is generally much larger compared to inputs than it is for surface water. This difference causes a tendency to use sub-surface water unsustainably for a long time. However, over long term the average rate of seepage above a sub-surface water source is the upper bound for average consumption of water from that source.

The natural input to sub-surface water is seepage from surface water. The natural outputs from sub-surface water are springs and seepage to the oceans. If the surface water source is also subject to substantial evaporation, a sub-surface water source may become saline. In coastal areas, use of a sub-surface water source may cause the direction of seepage to ocean to reverse which can also cause soil salinization. People can also cause sub-surface water to become unusable through pollution. The input to a sub-surface water source can be increased by building reservoirs or detention ponds.

- d) *Desalination* – Desalination is an artificial process by which saline water (generally sea water) is converted to fresh water. The most common desalination processes are distillation and reverse osmosis. Desalination is currently expensive compared to most alternative sources of water. It may be economically viable only for high-valued uses, such as household and industrial uses, in arid areas.

10.2.1.2 Project constraint and source constraints

Quality aspects of demand depend upon functional requirements, occupancy type, pattern of use, variety of uses involved, occupant use behaviour, cold and hot water quality requirements (temperature, pressure, etc), etc.

Water quality requirements are directly related to intended use. The fresh water is intended mostly for human consumption, whereas treated waste water is intended to be used for non-potable uses. All the water supplied shall meet or exceed appropriate water quality requirements as applicable for its use. Requirements include microbiological, chemical, radiochemical, and aesthetic requirements that are applicable to quality of water for its respective uses.

The quality of available water sources is often a very important factor in water system planning and design. The quality of water for respective uses such as for domestic, flushing, irrigation, process and construction requirements shall be in accordance with accepted standards and good practice [11(28)].

For estimation of Water Demand for respective types of occupancy, reference shall be made to *National Building Code of India: Part 9 Water Supply, Drainage and Sanitation*. Cold and hot water proportion are drawn based on the local climatic condition of the region, type of occupancy and the general use pattern in the local region.

10.2.2 Water Sourcing

Based on the functional assessment of need, availability, environmental concerns and their optimization, the water sourcing is decided. Following are alternative sources of water that are generally suitable for domestic/building water systems:

- a) Direct connection to an existing water system,
- b) Indirect connection to an existing water system (water hauling),
- c) Development of groundwater resources,
- d) Development of surface water resources, and

e) Revamping of traditional water sources.

In the vast majority of cases, in view of operation and maintenance considerations it may be desirable to connect to an existing water supply system.

During the planning stage of project development, each potential source should be carefully evaluated in light of the water quantity and quality requirements. The final choice of source depends on many factors, such as the following:

- 1) Proximity and capacity of existing systems,
- 2) Necessary institutional arrangements for obtaining water from existing systems,
- 3) Yield and quality of available ground and surface water sources, and
- 4) Level of operation and management activity that is reasonable for the water system being designed.

The source of water is an important factor in deciding which environmental regulations apply, which shall be complied with. For the purpose, the sources may be classified as groundwater, groundwater under the influence of surface water, and surface water. Generally, surface water and groundwater under the influence of surface water, are regulated together.

Source selection should depend upon environmental considerations, reliability, cost and water treatment facilities.

10.2.3 Hot Water Systems Planning and Design Approach

Water heating is a thermodynamic process using an energy source to heat water above its initial temperature. Typical domestic uses of hot water are cooking, cleaning and bathing. In industry, both hot water and water heated to steam have many uses. Appliances for providing a more-or-less constant supply of hot water are variously known as water heaters, boilers, heat exchangers, calorifiers or geysers. In domestic installations, potable water heated for uses other than space heating is known as domestic hot water. The most common energy sources for heating water are fossil fuels namely natural gas, liquefied petroleum gas, oil or sometimes solid fuels. These fuels may be consumed directly or by the use of electricity (which may be derived from any of the above fuels or from renewable sources). Alternative energy such as solar energy, heat pumps and hot water heat recycling may also be used as available, usually in combination with backup systems supplied by gas, oil or electricity.

Alternative of water systems such as electric, gas fired, oil fired and solar hot water systems; and hot water system using heat recovery are evaluated based on the availability and limitation of the fuel feed. Large centralized hot water generation on electrical power should be discouraged and alternative clean and energy efficient fuels with efficient hot water generator should be evaluated in the project having high hot water requirement.

10.2.4 Strategies for Water Efficiency

Efficient use of water is one of the underlying principles for sustainability in water management. Selection of water efficient products should be considered for both cold and hot water systems. Use of low flow fixtures for faucets, water closets, bath showers, hand-held bidet sprays, dish washers, aerators and clothes washers should be considered. One of the important considerations to ensure performance of low flow products is to design systems with correct pressures.

Low flow fittings should be considered mainly for areas with direct water consumption/human usage such as for wash basin taps, sink taps, and shower head, bath faucet and other faucet taps. Situations where water is filled for other requirements such as bath tub fillers, washing machine and for situations where water is filled, stored, used or situation where quantity of water supply may form the intent for which water is being drawn, need not be provided with water saving features/use. The strategy of water efficiency shall also include low flush and dual flush cistern/flushing mechanism.

Technologies for high efficiency toilets and waterless urinals are emerging technological solutions but they need to be validated in the realistic use environment. It is important to ensure that the user's functional needs and satisfaction is not compromised. Social attitudes and user habits may need analysis while selecting such products. Dual piping is another strategy for efficient use of water. Planning and design approach to recycled water use should be integrated with dual piping systems and waste water reuse systems. In such cases, control of contamination in potable supply pipe shall be ensured.

10.2.5 Strategies for Water Conservation

Water conservation strategies aim to conserve the scarce water resource. Storm water is a major opportunity for conservation. Rain water harvesting and rain water recharge, and rain water storage/use have a significant scope for conservation, specially at the neighbourhood level of developments. Rain water can be harvested by adopting the means of:

- a) Storing rainwater for ready use in containers above or below ground
- b) Charging rain water into the soil (ground water recharging) to improve the underground water table. This needs to be critically planned as recharge is governed by stratification, ground water table level and ground water quality.

While water conservation strategies are most desirable in water-deficient areas, the maintenance of rainwater harvesting system assumes importance, else, they may not perform during raining days. For details reference may be made to **7.2**.

10.2.6 Sustainable Design Detailing of Water Supply System Components

Project context is the key determinant of selection of system technologies and their integration with other engineering systems. For a system to be sustainable, the aspects of integrated performance, reliability, maintainability, life cycle performance including under adverse conditions and capability to undergo corrections during the use phase of the buildings, shall be considered. Pre-validation of integrated system performance is desirable. It is also desirable to consider implications of procurement,

contractually assigned responsibilities and technical support during and installation procedures. Quality assurance and quality control systems shall be employed to guide system design and execution.

10.3 Planning and Design of Waste Water System

This involves, quantity and quality assessment study, study of domestic water use-profile and scope of recycled water use, system conceptualization and integration with other water systems; planning for collection, treatment systems (combined and independent sewage and sullage treatment plant), treatment of on-site grey water and reuse. Sludge drying and use for manure, recycle and hygiene considerations.

10.3.1 Treated Waste Water Use for Landscape and Irrigation

To reduce fresh water consumption for landscape/irrigation, it is suggested to use alternative sources of water, such as grey water, reclaimed water and collected rainwater. Grey water is untreated household waste water from bathroom sinks, showers, bathtubs, and clothes washing machines. Grey water systems pipe carry this used water to a storage tank for later outdoor watering use. Reclaimed water is waste water that has been treated to levels suitable for non-potable uses. Collected rainwater is rainwater collected in cisterns, barrels or storage tanks.

Appropriate systems to monitor the quality of treated waste water in accordance with the standard practices should be provided analyzing building use. Required safeguards should be provided and records of treated waste water parameters should be monitored on regular basis.

Proper techniques for landscaping and irrigation in respect of selection of appropriate species, use of efficient irrigation systems, etc can result in substantial water saving (see also 7.1 and 7.3).

10.4 Water and Waste Management During Construction

10.4.1 Water Use During Construction

Water from only authorized sources should be used for construction. Use of potable water for construction should be avoided unless required for specific purposes. It is suggested to consider use of treated waste water from appropriate sources with quality of treated waste water parameters confirming the quality required for use in construction activity. *Water quality for concreting work shall be in accordance to National Building Code of India: Part 6 Structural Design: Section 5A Concrete.* For sourcing of water, reference should be made to the statutory environmental provisions, if applicable. Inadvertent use of non-potable construction water for drinking purpose shall be prevented by proper distinct systems with appropriate markings. Wastage of construction water in piping network as well as storage tanks shall be prevented. Monitoring of water consumption shall be done by maintaining logs to control wastage and ensure its efficient use. Water efficient construction technologies should be considered along with other implications while deciding on the technology for respective construction activity.

10.4.2 Control and Use of De-watering Output

De-watering is essential for carrying out construction works below water table. The extent of de-watering is decided on structural considerations. Assigning responsibility within the organization shall ensure control of excessive de-watering. De-watering operations generate enormous amount of water. Organizations should explore to use water obtained as a result of de-water either at the site of construction or at another location productively.

10.4.3 Management of Waste Water

Construction sites may have a constraint of not having a waste-water disposal, hence, the arrangements have to be made within the construction site. It is imperative that the opportunities are identified to reduce the water consumption and re-use waste-water. In the absence of appropriate waste-water disposal facilities, unhygienic and unsightly conditions may prevail which may cause water borne diseases and act as breeding ground for mosquitoes. Wastewater at construction sites may contain residues of construction materials (such as cement, sand, bentonite slurry, etc), oils and domestic waste. It should be possible to treat water, specially containing residues of construction materials and re-use the same in construction. However, disposal of other forms of wastewater should be planned in suitable manner at site after appropriate treatment.

10.4.4 Waste Management During Construction - Refer 12.7.

10.5 Process Water Requirement and Effluent Treatment

Certain processes, such as pharmaceuticals, hospitals, industrial processes, etc., need water quality specific to their needs. Water for such processes is to be provided in accordance with industry standards applicable to the respective industries as well as the applicable statutory environmental provisions. Therefore, planning and design of water supply schemes for such processes shall adhere to the concerned regulations and standards.

Effluent treatment of some special processes is a cause of concern. The impact of treatment of water for supply as well as process effluent shall be assessed through Environmental Impact Assessment (EIA). Environmental Management Plans (EMP) should be developed to mitigate the adverse environmental impacts. In such situations, it is desirable to establish proper Environmental Management System to ensure compliance to the norms through defined managerial responsibility. For such special process facilities, proper water and effluent quality testing laboratory shall be established and records maintained to control compliance parameters.

10.6 Planning and Design of Solid Waste Management System

Solid waste generated in buildings, if not managed properly may result in unhygienic conditions, spread of foul smell, unsightly conditions and hazards such as fire within the buildings, and hindrance in productive use of building. The solid waste has also bearing on the functional planning of buildings. Collection and movement of solid waste often overlaps with building circulation and, hence can cause interference with the use, that may be prohibited in occupancies such as hospitals and hotels. Thus,

the interventions during planning and design are critical for solid waste management. Fig. 17 shows a schematic diagram indicating solid waste management system.

The cumulative effect of improper solid waste management in buildings and it's in discriminate dumping in landfill sites, is an environmental problem of immense proportions. While reduction of solid waste is aimed during building use, as a part of solid waste management it should be considered to utilize the considerable scope of using solid waste as a resource for waste recycled products and energy. For this, solid wastes recycle facilities should be considered for building complexes. The aim should be to reduce the burden on municipal waste disposal facilities and thereby, reduce the need for transportation of wastes. Solid waste processing may include sorting out various materials and compacting for effective onward transport to re-cycling plants.

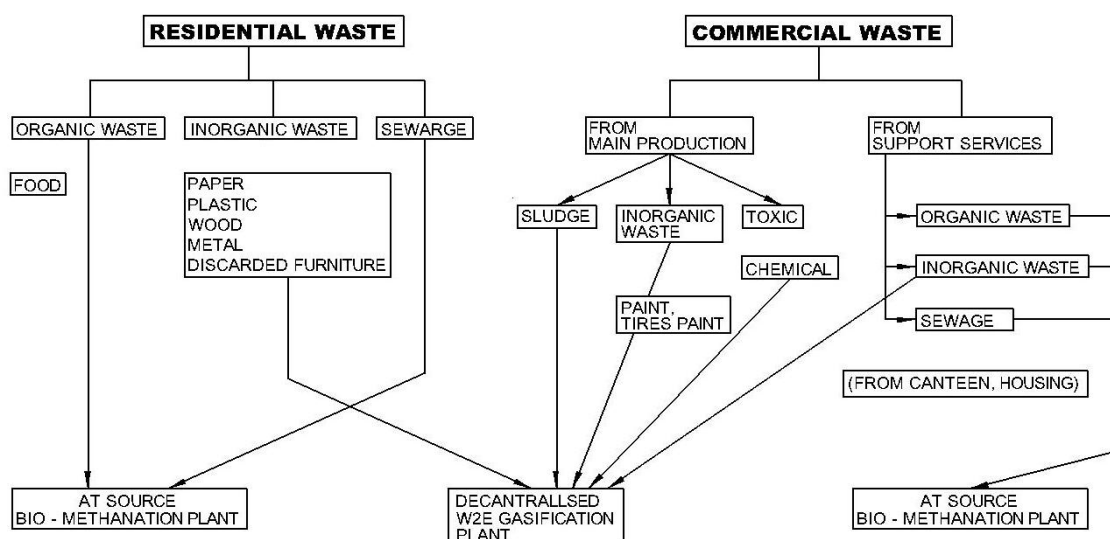

FIG. 17 TYPICAL SCHEMATIC DIAGRAM INDICATING SOLID WASTE MANAGEMENT SYSTEM

10.6.1 Documentation of Nature of Waste and Quantification

For proper planning and design of solid waste management, study of various functional areas shall be carried out. The study should include identification of solid waste that may be generated during use, their characteristics and the anticipated quantities. It may be desirable to study similar projects and take cognizance of their experiences while undertaking such identification.

It may also be desirable to study the socio-cultural context affecting behavioural aspects of users to anticipate extent of their participation in solid waste management process and appreciation of systems implemented. In planning solid waste management system from sustainability point of view, the role, responsibilities and response of users should be considered. The context of users, characteristics of waste and expected quantities shall be documented for making strategic decisions.

10.6.2 Identification of Strategies for Solid Waste Management

Considering the solid waste characteristics, expected quantity, socio-cultural context of users and possible technological solutions, strategic planning of solid waste management shall be developed. Technological and managerial alternatives shall be explored and compared. Reference shall be made to the statutory provisions governing building use and the environment. While developing strategies, the following aspects shall be considered:

- a) Solid waste minimization;
- b) Space requirement for collection, movement to sorting and for disposal, including on-site processing and off-site transport in accordance with legal provisions;
- c) Effectiveness of possible alternatives;
- d) Environmental sensitivity for solid waste processing and constraints of off-site disposal;
- e) Organizational constraints of building occupants to participate and involve in management of solid waste; and
- f) Economic considerations of technology and their reliability.

The strategic approach to solid waste management shall be documented as a report that shall form a basis of planning and engineering services design.

10.6.3 Solid Waste System Planning

Documented strategic approach should lead to planning of the system as the preliminary design begins to evolve. Design configuration shall consider solid waste management also as one of the functions of the building. Planning and design shall include appropriate physical space requirements for:

- a) Provision for collection at suitable locations for solid waste to facilitate the occupancy functions;
- b) Need for ventilation, washing, isolation and provision for persons performing duties of waste collection;
- c) Provision of appropriate containers for wastes;
- d) Circulation planning for solid waste from individual collection locations to central facility (for example, waste chutes, physical movement through service corridors, etc);
- e) Segregation space with necessary illumination, ventilation, washing and other provisions for performing segregation duties at appropriate location(s); and
- f) Treatment facility within the building or building complex for compacting for recycling and disposal (for transport to city level facility), composting for biodegradable waste, re-cycled materials, and heat recovery during disposal through thermal chambers.

A schematic plan for solid waste management shall be developed and coordinated with the building plan. Schematic plan shall also indicate technologies employed in the process of solid waste management after due consideration to alternatives, cost implications to the project; statutory approvals that may be needed; specifications of civil and engineering works needed to be executed, contractual conditions for

executing agencies; etc. Documented plan shall be the basis for preparing detailed designs.

10.6.4 Design Detailing of Solid Waste System Elements

Design of solid waste system shall coincide with detailed architectural and engineering design. While physical space requirements are necessary for the architectural design, design calculations for engineering services requires inputs from various elements of waste management. Design detailing should be adequate to ensure information needed for vendor selection and tender action.

System design detailing shall ensure that the components are compatible with each other. For instance, the design of segregation facility shall consider aggregate space requirement arising out of various collection locations. Similarly, the quality of finishes should be compatible with the nature of waste and the processes needed.

From sustainability considerations, it is desirable that the representative group and other stakeholders review the proposed solid waste management system, including technical and managerial component, so that the performance is assessed from multiple standpoints.

10.6.5 Provisions for Waste(s) Requiring Special Management

Wastes generated in special occupancies and processes need safe handling and disposal in accordance with industry practices, and statutory and environmental laws. Buildings are required to make special provisions, physical spaces and measures to collect, segregate, transfer and dispose off the waste. Management system should be established for disposal of such special wastes. Management systems should define delegation of responsibilities, prerequisite competencies, procedures, protection for personnel performing waste management duties and procedures for emergencies and disaster management. Issues related to wastes requiring special management shall be taken care of as follows:

- a) *Bio-medical Hospital waste management* – Hospital wastes include human parts, infectious materials and radioactive materials. Each of the waste types shall be collected and segregated at designated locations as per norms applicable. The circulation route for waste shall be segregated from other hospital circulations. Location for further processing of waste for final disposal shall be defined at the master planning stage. Special care shall be taken for ventilation exhaust so that the same does not mix with air intakes in hospital ventilation system. The hospital waste shall be treated using appropriate technologies like incineration, autoclaving, microwave or hydroclave and also as per the statutory laws and procedures.
- b) *Management of radioactive waste* – Disposal of radioactive waste shall be carried out strictly in accordance with the Board of Radiation & Isotope Technology (BRIT)/ Atomic Energy Regulatory Board (AERB) regulations/guidelines. In such cases, proper records shall be maintained as required by the regulatory Authority concerned.

- c) *Management of toxic and chemical waste* – Toxic chemical wastes shall be disposed off according to the relevant regulations, standards and best industry practices. Specific arrangements shall be provided for management of emergencies such as control of spread of toxic fumes and emergency health care to the exposed populations.
- d) *Management of inflammable and combustible wastes* – Combustible and inflammable waste is a potential source for fire hazards in buildings. Collection, segregation and handling of such wastes shall not be carried out in vicinity of any source of ignition. Adequate provisions for spread of smoke and fire-resisting enclosures shall be provided at locations for collection and segregation. Necessary fire protection measures, such as portable extinguishers, fire hydrants and sprinklers should be provided considering fire risk, damage potential and statutory provisions. Provisions under explosives act shall be followed for storage and disposal, as applicable.

10.7 Integrated Approach to Water Supply, Water Waste and Solid Waste Management

Significant liquid and solid waste generation is witnessed and recorded in the urban areas of the country. The municipal solid waste generation ranges from 0.25 to 0.66 kg/person/day with an average of 0.45 kg/person/day. In addition, large quantities of solid and liquid wastes are generated by industries. Most of the wastes generated find their way into land and water bodies, emitting gases like methane and carbon dioxide resulting in bad odour, and air and water pollution as well as increasing in the emission of greenhouse gases, if not properly treated. This problem can be significantly mitigated through adoption of treatment and processing before disposal and adopting waste to energy technologies. It not only reduces the quantity of wastes, but also improves its quality to meet the required pollution control standards and regulations, besides generating substantial quantity of resources and energy.

11 BUILDING SERVICES OPTIMIZATION

11.1 General

Optimization of electro-mechanical services is one of the important aspects towards achieving a sustainable building. Reduction in heating, cooling and lighting loads through climate-responsive designs and conservation practices can enhance the energy efficiency of a building. In addition, an integrated project delivery (IPD) approach results in a well-designed, cost effective solution wherein all building systems and components can in coherence facilitate overall functionality as well as required environmental performance. The passive design features and proper initial planning helps in reduced energy demand and, therefore, the same should be carefully analyzed prior to actual sizing of equipment where provided.

11.2 Concept Development

In addition to achieving the optimum energy performance, the building should also provide the desirable thermal and visual comfort to its occupants. Incorporating solar passive techniques in a building optimizes building performance by minimizing the use of artificial energy and thereby minimizing load on conventional systems for heating, cooling, ventilation, lighting, etc.

Solar passive techniques that can be adopted in different climate zones of India are:

- a) landscaping (to reduce heat island effect);
- b) optimum building orientation;
- c) arrangement and shape of buildings;
- d) effective surface to volume ratio;
- e) location and size of openings on building facade;
- f) glazing type and performance;
- g) shading devices on windows and judicious selection of building materials.

Prior to developing the design drawings, the design team shall carry out a thorough review of the fundamental assumptions, owner's brief and available resources on site, in an integrated manner, addressing the key target issues such as the following:

- 1) *Building orientation* – Building orientation affects many aspects ranging from energy performance to visual simulation of the building. Building location and its exposure to solar direct radiation affect the HVAC design, day-lighting strategies and the overall energy demand.
- 2) *Building envelope* – Building envelope provides a starting point for determining heat transfer coefficients for external walls/ceiling/roof and glazing (see 8 for details).
- 3) *Harvest site energy* – Project shall explore the use of natural resources such as daylight, variations in ambient temperature (economizer cycles) to reduce cooling/heating demand and utilize solar/wind energy. For large projects, the master planning team should explore district level solutions and identify potential site integrated opportunities.
- 4) *Design assumptions and internal load assessment* – Energy demand reduction may be accomplished by carefully analyzing the initial design assumptions and by reducing internal heating and/or cooling loads and interior lighting improvement. It can be achieved through multiple design strategies such as reducing the overall building footprint, reviewing the indoor temperature design criteria to allow for a wider acceptable band, on-demand operation of utilities (using sensors to link the operation to an established criterion), climate responsive envelope, etc.
- 5) *Maximize efficiency* – Energy consumptions should be optimized to avoid over-sizing of equipment rating. It may be achieved by analyzing the estimated monthly and annual energy consumption profiles of the building and compare the same with building peak loads. Computer based design tools may be used to identify feasible energy conservation measures for a building.

11.3 Natural and Mechanical Ventilation Strategies

The term natural ventilation is used to describe air movement caused by naturally produced pressure differences due to wind and the stack effect. Natural ventilation is achieved by infiltration and/or by allowing air to flow in and out of a building through doors and windows openings. Typically, preferred mode of ventilation in non-air conditioned spaces is by natural draft or convection. A thorough assessment of natural versus mechanical ventilation strategy should be performed to minimize the need for artificial cooling by lowering the space temperatures (of attics) as well as eliminate/minimize the need for mechanical blowers. For this, validation through computer simulation may be helpful. Following are some of the important aspects which may be considered for the purpose:

- a) *Stack effect* – Convective air currents may be induced in a building by exploiting temperature difference between a space and the environment adjacent to it as the lighter warm air rises to be replaced by cooler air. This phenomenon may be specially useful for ventilation in tall buildings, vertical passages such as stairwells, elevators, and shafts. This helps in reducing the fan power energy demand.
- b) *Wind-induced pressure differences* – Wind pressure on a building depends on wind direction, speed, shape of the building and location of its openings. The spatial cooling techniques may be explored through windows/openings to induce airflow from the windward side and outflow on the leeward side. This is specially suited for tall buildings.
- c) *Night purging* – Night purging takes advantage of the diurnal variation in temperatures to lower the cooling demand of the space. In regions, where a significant difference exists between day and night temperatures, this technique is useful for dissipating heat by flushing the indoor space through ambient cool air.
- d) *Wind towers* – Use of wind towers may be explored in hot and dry climates for cooling. The function of this tower is to catch cooler breeze that prevail at a higher level above the ground and direct it into the interior of the buildings. Wind towers operate in many ways depending on the time of day and wind availability.

11.4 Passive Heating Techniques

Passive heating is the spontaneous warming effect resulting from the absorption of solar radiation wherein solar energy is exploited to induce heat flow from the affected surface to indoor air, as well as promote heat storage within the building structure. In the climatic zones requiring indoor space heating, it may be explored to use the following strategies:

- a) *Direct gain method* – Controlled sun may be permitted into the habitable spaces through an opening to directly heat the floor, walls or other internal components and objects, which, in turn, heat the air within the room. Some examples of building materials that enable direct solar gain by acting as thermal storage mass are concrete, bricks, stone and water. The high thermal mass is usually located in the internal or external walls, floors or other built-in structures that receive sun directly.

- b) *Indirect gain* – A thermal storage wall may be placed between the glazing and habitable space which prevents solar radiation from directly entering the living space. The solar energy incident on wall is absorbed by the wall and then indirectly transmitted to the habitable space over a longer time.
- c) *Trombe wall* – Trombe wall is a thick solid wall with vents at its lower and upper ends. This wall may be placed directly behind the glazing with an air gap in between. The vents act as inlets of warm air into the room and as outlets for flushing out cool air from the room.
- d) *Solar chimneys* – This system is a kind of modified trombe wall that is incorporated into the roof. A solar chimney is essentially a collector panel with minimum thermal inertia on the south façade of the building. It absorbs incident solar radiation and heats up the air inside the space.
- e) *Sunspaces/Solaria* – A sunspace is an integration of direct gain and thermal storage concepts. Solar radiation admitted into the sunspace heats up the air, which by convection and conduction through the mass wall reaches the habitable space. It essentially consists of a greenhouse constructed on the south side of the building with a thick mass wall linking the two.

11.5 Passive Cooling Techniques

Passive cooling systems rely on natural heat sinks to remove excess heat energy from a building. They derive cooling directly from evaporation, convection and radiation without using electrical energy. All strategies rely on diurnal changes in temperature and relative humidity. The applicability of each system depends upon the prevailing climatic conditions.

The building envelope can be designed to effectively exchange heat with the surrounding ambient air. In order to have an appreciable net heat flux between two bodies, the temperature difference should be significant (typically at least 7 °C). Some of the techniques are as follows:

- a) *Nocturnal cooling* – In this technique, night sky cooling may be very effectively used to dissipate the heat stored in building envelope so that it is regenerated to store the day heat gain. Such buildings will require high thermal mass and application is ideally suited for day use buildings such as offices.
- b) *Roof pond with movable insulation* – A water body on the roof may provide cooling wherein during summers it is covered with insulation with a surface finish of low absorptivity. During the day time, this minimizes the solar radiation impact on the roof, as the water in the pond holds the heat gain and further increases the time lag. During the night, insulation is removed and the heat stored in the day time is exchanged with the night sky. In winter, the operation of the movable insulation is reversed to allow heat gain in daytime and reduce heat loss during the night.
- c) *Courtyards* – Due to incident solar radiation in courtyards, the air gets warmer and rises. Cool air from ground level flows through louvered openings of rooms thereby inducing airflow.

11.6 Pre-Cooling of Ventilation Air

To conform to the IAQ requirements, it is necessary to introduce outside air for ventilation of conditioned spaces. This enables reduction in internal air-contaminants, as well as dilutes odour from occupants. The introduction of hot and humid air leads to significant increase in cooling/heating load and, therefore, strategies, as follows, may be considered to minimize the energy demand:

- a) *Demand controlled ventilation* – Carbon dioxide or air quality sensors may be used to check the level of pollutants in the occupied space and provide the indication to building management system to control the opening of outside air dampers thereby effectively providing ventilation on demand.
- b) *Heat Recovery* – Pre-cooling of hot/cold outdoor air can be achieved by recovering energy from exhaust streams of a building (toilet/pantry/atrium) through either heat recovery wheel, run around coils, cross plate heat exchangers or heat pipes. This helps in lowering the installed capacity of cooling/heating equipment.
- c) *Economizer Cycles* – In certain climates, air and/or water side economizer cycles may be used to take advantage of lower ambient air temperatures. Outside air load may be reduced by pre-treating the air and possibly combining strategies like earth air tunnel and adiabatic cooling.

11.7 Low Energy Mechanical Cooling Techniques

It is desirable to explore possibility of using low energy cooling/heating techniques for indoor space as an alternate for compressor driven energy intensive conventional air-conditioning systems. Passive systems in combination with mechanical systems may also be suitably hybridized to offer systems that have significant lower energy consumption in comparison to conventional HVAC systems. The following alternative technologies may be considered for implementations to comply with the comfort criterion:

- a) *Evaporative cooling* – It is suited for hot climates with low humidity. The cooling of air is achieved by simple evaporation of water in air. In high humid climates, evaporative cooling may have little thermal comfort benefit beyond the increased ventilation and air movement it provides. Various types of evaporative coolers are as follows:
 - 1) *Direct (single stage) evaporative cooling (open circuit)* – It lowers the temperature of air by using latent heat of evaporation thereby changing water to vapour state.
 - 2) *Indirect evaporative cooling (closed circuit)* – It is similar to direct evaporative cooling, but uses a heat exchanger. In addition, in indirect evaporative cooling, the cooled moist air does not come in direct contact with the conditioned environment. Efficiency of these systems is low as compared to direct evaporative cooler.
 - 3) *Two-stage evaporative cooling or indirect-direct system* – It does not produce humidity levels as high as that by traditional single-stage evaporative coolers, but operate at a lower efficiency. Two stage evaporative coolers combine indirect with direct evaporative cooling.
 - 4) *Passive (or natural) downdraft evaporative cooling (PDEC) system* - It is a low energy passive system. PDEC system do not need the blower and

require only pump for re-circulating water. Some designs may even eliminate the re-circulation pump and utilize the pressure in the supply water line to periodically surge water over the pads thereby eliminating the requirement for any electrical energy input.

- b) *Desiccant dehumidification/cooling systems* – Desiccant dehumidification/cooling technology provides a tool for controlling humidity levels for conditioned air spaces.
- c) *Geothermal heating and cooling* – Geothermal heat pumps (GHP) use the constant temperature of the earth as the exchange medium instead of the outside air temperature. As the ground is warmer than ambient air during winters and cooler than ambient air during summers, GHP harnesses this phenomenon by exchanging heat with the earth through a ground to water/air heat exchanger. Thus it helps in meeting indoor heating/cooling demand and also hot water generation for small scale buildings like homes and commercial establishments. Geothermal heat pumps can be classified as closed looped system and open loop system. The pipes can be installed in three ways, namely, vertically, horizontally and in a pond or lake, depending upon the availability of land area and soil type at the chosen site.
- d) *Earth air tunnel system* – As earth temperature remains constant throughout the year at a depth of 4m to 5m, an earth air tunnel (EAT) is created by burying a pipe at this depth. Ambient air, thus sucked from one end is passed through EAT and depending on the ambient temperature, air gets cooled in summer and heated up in winter. This cooled/heated air is then supplied to the various areas in the building for meeting space cooling/heating demand and can provide recommended thermal comfort to the building occupants.
- e) *Radiant cooling or thermally active building systems* – These systems work on the principle of thermal storage of energy (heating/cooling) within the building structure components such as slabs, false ceiling, walls, etc. Further the building components radiate the heat/coolness to the building interiors thereby off-setting the heating or cooling loads. These systems specially work best in climates with high diurnal variations. These systems can be integrated with the HVAC system or can operate independently.

11.8 HVAC System

The following may be considered with regard to planning, design and installation of HVAC system:

- a) *Equipment Sizing* – As the air-conditionings systems account for nearly 50-60 percent of annual electricity bill for a conditioned building, prior to equipment selection, it is important to optimally size the cooling and heating equipment of the building. As the internal loads may not peak simultaneously at any given time, a suitable diversity factor may be considered for sizing the equipment or multiple smaller machines may be installed for ensuring operation at highest efficiency point in spite of variation in demand.

- b) *Unitary Equipment* – The unitary products like window air-conditioners and split units are ideally suited for standalone smaller applications like houses and shops. However, the IAQ and energy efficiency needs a special attention. These shall conform to relevant Indian Standard specifications.
- c) *Variable Refrigerant Flow Systems* – These are popular systems for middle size establishments like shops and large residences and can provide a superior performance over conventional unitary equipment/package units. However, the IAQ, redundancy and long refrigerant pipe lengths required, need a special attention.
- d) *Central Plants* – These are ideally suited for all medium and large scale projects that require air-conditioning wherein the chilled water is transported to remote air terminal units for heat transfer. The water chilling machines (chillers) are categorized with respect to type of compressor and heat transfer mechanism. Their selection calls for a careful review in terms of anticipated variation in load, part load efficiency, redundancy etc. The benefits of central plants include highest efficiency, reduced maintenance costs and overall lower total installed capacity (due to overall diversity) in comparison to other options.
- e) *Water Chilling Machines (Chillers)* – Chillers may be used either singularly or in groups and in either air-cooled or water-cooled options. As a guideline, air-cooled chillers are recommended as last option when water is either in scarce supply and/or expensive. Water-cooled chillers are more energy efficient than their air-cooled chillers but do require a cooling tower which demands a supply of suitably treated water. They have a longer operational life and are often selected for larger capacity applications. It is worthwhile to explore possibility of hybrid cooling options or closed cell cooling towers to reduce energy consumption. The use of recycled water from a sewage/effluent treatment plant for cooling tower make-up is desirable.

There are two recognized methodologies to determine chiller efficiency namely coefficient of performance (COP) and integrated part load value (IPLV). This offers a mathematical way to rate and compare single chillers but is not suitable for multi-chiller configurations. With energy modelling, multi-chiller configurations may be simulated with greater accuracy. Early use of recognized modelling software in the design process may help in addressing common design shortcomings such as, the tendency to over-size chiller installations.

Parameters that need to be optimized while designing a chiller-water plant include flow rates and temperatures, pumping options, plant configuration and control methods. For each specific consideration, the design professional should understand the owner's need, objectives and implement the chiller plant options to best satisfy them.

It is also worthwhile to look at other energy saving strategies like Heat recovery (heat pumps/de-superheater), low flow applications (higher ΔT) on chiller and condenser, low approach cooling towers, series counter flow configuration, use of variable frequency drives, advanced controls, water economizers, lower fouling factors, higher chilled water temperature, etc for reducing the energy demand.

- f) *Refrigerants* – Manufacturers and designers should adopt balanced approach while selecting refrigerants. Some of the key criteria to be considered are as follows:
- 1) Ozone depletion potential (ODP);
 - 2) Global warming potential (GWP);
 - 3) Energy efficiency- part load, full load, system;
 - 4) Flammability; and
 - 5) Toxicity.

One of the most widely used refrigerants is HCFC-22 (R-22) for air conditioning applications. Some of the alternatives to R-22 are not pure (single component) refrigerants but mixtures of refrigerants. HFC blend R-410a is also one of the most popular alternatives, having zero ODP. R410a has higher GWP and the efficiency of the system tends to be lower and it degrades more rapidly at higher ambient temperatures as compared to that of R22. Hydrocarbons particularly Propane has also been used as a refrigerant in air conditioners. For ODP and GWP of different refrigerants, reference may be made to Table 8.

Table 8 ODP and GWP Values of Different Refrigerant Types (100 year values)

Chlorofluorocarbons	ODP	GWP	Common Building Applications
CFC-11	1.000	4,680	Centrifugal chillers
CFC-12	1.000	10,720	Refrigerators, chillers
CFC-114	0.940	9,800	Centrifugal chillers
CFC-500	0.605	7,900	Centrifugal chillers, humidifiers
CFC-502	0.221	4,600	Low temperature refrigeration
Hydro Chlorofluorocarbons			
HCFC-22	0.040	1,780	Air conditioning, chillers
HCFC-123	0.020	76	CFC-11 replacement
Hydrofluorocarbons			
HFC-23	~0	12,240	Ultra-low-temperature refrigeration
HFC-134a	~0	1,320	CFC-12 or HCFC-22 replacement
HFC-245Fa	~0	1,020	Insulation agent, centrifugal chillers
HFC-404a	~0	3,900	Low-temperature refrigeration
HFC-407c	~0	1,700	HCFC-22 replacement
HFC-410a	~0	1,890	Air conditioning
HFC-507a	~0	3,900	Low-temperature refrigeration
Natural Refrigerants			
Carbon dioxide (CO ₂)	0	1.0	
Ammonia (NH ₂)	0	0	
Propane	0	3	

- g) *Chilled Water Pumping Systems* – In a central plant, the pumping systems contribute to second largest energy consumption source and it should be carefully analyzed for selection for highest efficiency point and required head only. It is recommended to install variable frequency drives for all large applications. There are following two types of chilled water pumping system options:

- 1) *Primary-Secondary (Decoupled) System* – In this system, flow rate through each chiller remains constant and yet accommodates a reduction in pumping energy, since the system water flow rate varies with the load.
 - 2) *Primary Only Variable Flow (PVF) System* – In this system, flow varies through evaporator. It helps in saving on initial as well as operating costs/energy. The control strategy/priorities of a PVF system are significantly different from that of a primary-secondary system.
- h) *Thermal energy storage (TES)* – TES is a technique ideally suited for utilizing advantage of differential power tariff and power rationing during peak load hours. This becomes a tool for use by the designer as conventionally peak load may be considered as refrigeration load for selecting equipment capacity; thus, in such case most part of day refrigeration machine operates at part loads or kept idle. To overcome this shortcoming, concept of thermal energy storage may be evaluated to store the energy during the time when load is less than installed capacity and releases the energy when the load is more.

Thermal storage systems may be suitable for situations wherein, due to water shortage the usage of water cooled chillers are limited. The air-cooled chillers may run during nights when the ambient temperatures are lower. Also, the technique may help reduce the size of the refrigeration equipment, installed electrical sub-station equipment and power back up requirement. It is also recommended to evaluate the option of placing ice storage tanks in parallel/series arrangement.

- i) *Vapour absorption system* – Alternate sources of energy particularly waste steam/heat may be used for refrigeration. One such system uses water as the refrigerant and lithium bromide as the absorber. It has less moving parts and hence results in lower power consumption. Vapour absorption system may also utilize waste heat from the diesel generating sets/bio-waste using heat recovery boilers or heated water from the solar panels to produce cooling in buildings.

Vapour absorption machines may also be considered in co-generation systems.

- j) *Air handling units* – Choice of air handling units with supply and return/exhaust air fans may help in energy saving. During free cooling conditions when the ambient temperature is comfortable, the supply fan draws all outside air, whereas the return/exhaust fan exhausts the air from the conditioned area. The air handling unit with dual speed motor may be used so as to meet the varied air quantities for various seasons. This can work in tandem with a variable frequency drive.

The air handling units work in sequence with heat recovery wheel with which the fresh air drawn may be cooled by return air resulting in energy saving while maintaining the IAQ levels which requires higher outside air. Toilet exhaust fans may be connected with an infrared sensor/timer or such other means which, facilitates operation only during occupancy.

- k) *Server rooms/data centre* – Facilities such as server rooms and data centre that require round the clock operation and high energy demand are beyond the purview of this document. However, as smaller server and hub rooms are part of every building that has multiple computers, for such installations use of dual fluid precision units may be considered. When the chiller is in operation the unit is running in chilled water mode and shifts to direct expansion (DX) mode when the chiller is not functional. When the chilled water temperature is maintained higher, it can run on both chilled water and refrigerant mode so as to meet the duty conditions. The blowers may be of variable volume type or with electronically commutated (EC) motors to meet varying duty conditions.
- l) *Fans and Blowers* – Proper selection of a fan for a given application requires consideration of the following factors:
- 1) Required air flow (volume);
 - 2) System pressure drop at required flow;
 - 3) Operating point;
 - 4) Type of installation namely, ducted or free flow;
 - 5) Air flow configuration, for example direction of inlet and outlet flow;
 - 6) Nature of air to be handled namely, clean, contaminated or hot; and
 - 7) Space constraints.

It is recommended to select high efficiency fans and couple them with equally efficient motors (preferably high efficiency/ EFF 1 type). Use of EC motors can also be a viable option for lower rating fans. Other factors such as type of belts (V or flat), airflow (axial/centrifugal/mixed mode), fan types (backward/forward/plug) and use of guide vanes, may be considered appropriately.

- m) *Air distribution* – The design of an air distribution system should take into consideration the factors of occupant variables and space conditions so that occupants' heat loss is maintained at a comfortable rate. Occupant variables include activity level, metabolic rate and clothing levels. Space conditions are influenced by dry bulb and radiant temperatures, relative humidity and air velocity. Various types of air distribution methodologies that may be adopted on a project are:
- 1) *Mixing air systems*- To improve the efficiency of such mixing air systems, a careful analysis of the energy savings accrued due to improved COP such as the increase in fan power should be carried out for effective implementation. Most mixing air systems tend to be designed using a constant volume flow in the occupied zone. A good strategy for optimizing energy usage should be to examine the feasibility of incorporating a pressure independent, variable air volume system. Such systems can constantly monitor the air flow needs in any occupied zone and continuously modulate the air flow to the occupied zone.
 - 2) *Variable air volume systems* – Cabins and conference areas which have partial usage may be provided with variable air volume units so that they may be operated based on the usage which further results in energy

saving. Variable air volume units coupled with motion sensors enables closure of the units to the minimum levels to enhance energy efficiency.

Open areas may also be provided with variable air volume units for various zones so that the zones may be operated based on the usage. They may be actuated by a motion sensor so that the VAV will close to the minimum position in the un-occupied areas. Variable air volume unit further facilitates change of temperature set points during various seasons. Zones located in the building periphery which have the direct solar exposure should be equipped with variable air volume units.

- 3) *Displacement Systems* – In the case of displacement systems, while evaluating the primary air flow, complete mixing is not assumed. Only direct heat infiltration into the occupied space from all the fabric load is considered for the room sensible heat evaluation. All fabric loads from walls and glazing above the occupied zone, the loads from the ceiling, lighting, etc should be accounted for, for determining the return air heat gain. This results in significantly lower primary air requirement, leading to smaller fan and fan motor sizes. In addition, due to the higher primary air temperature, the COP of the refrigeration system may be significantly improved.

The ventilation efficiency of the displacement system is generally about twenty percent higher as compared to a mixing air system. This permits the use of lesser volumes of outside air for ventilation. As the primary air is admitted directly into the occupied zone, it shall be done at very low air speeds to avoid uncomfortable drafts. This results in low outlet velocity, low noise levels and pressure drops leading to quieter operation, improved thermal comfort, increased energy savings and improved IAQ.

- 4) *Under-floor air distribution systems* – A well-designed system requires less energy and is more flexible in providing and maintaining building services than traditional overhead systems. Low operational static pressures in the under floor air supply plenum may help to reduce central fan energy use. In such system, the thermal exchange with surroundings is reduced leading to better efficiency. For improved thermal comfort and maximized energy savings, it is also possible to provide under-floor VAV terminal units. A ducted system facilitates the use of under-floor VAV Units, particularly in perimeter zones or in special zones that are subject to load variations. It is desirable to insulate the under-floor to prevent thermal gain, specially if the floor below is at elevated temperatures, and also to prevent condensation on the ceiling slab below.
- 5) *Chilled beam and slabs systems* – Chilled beams and slabs are increasingly finding acceptance for energy efficient, comfortable, quiet operation in a robust system with very few moving parts and low maintenance needs. The system benefits from the increased density and energy carrying capacity of water, hence are more energy efficient than forced air systems.

- n) *Ducting* – The ductwork should be appropriately sized and balancing dampers need to be installed to reduce velocity losses. Ducts with larger cross sectional areas have much lower resistance and can reduce fan energy significantly. Duct having cross-sectional shapes such as round or oval can further reduce losses. Lower air speeds in duct reduce energy needs and noise. Ducts should be insulated and sealed but indoor air quality issues should also be considered. Factory made ducts with good workmanship may result in the lower leakage losses.
- o) *Variable speed drives* – Variable frequency drives (VFDs) are used for energy saving. These drives may be used for the primary and secondary chilled water circulation pump sets by sensing the temperature and pressure differential in the chilled water lines. Two way motorized valves in the air handling units may be actuated by a thermostat which vary the flow according to the loads resulting in pressure changes which may be sensed and used for changing the speed of the pump sets.

Variable speed drives are used for the air-handling units. Variable air volume units regulate the airflow for various zones based on the occupancy and temperature by a variable air volume unit, which gives a pressure signal for the VFD to change the speed of the air handling unit.

A demand controlled ventilation system uses a variable speed drive operating based on the opening and closure of the fresh air dampers controlled by the carbon dioxide sensors. A typical basement exhaust system may use a variable speed drive controlled by carbon monoxide sensors centrifugal/screw chillers with variable speed drives.

Projects in composite climate with 24 h working schedules may incorporate free cooling systems.

- p) *Controls* – Usage of accurate/sensitive controls may save power by 10 to 20 percent. Building control system plays an important part in the operation of a building and determines whether many of the sustainable design aspects included in the original plan actually function as intended. The main objective is to improve the quality and supply of information on the air-conditioning system and to thereby reduce the operating costs. The system can establish basis which may be used as bench mark for energy efficient operation subsequently.

11.9 Electrical System

Efforts should be made to select electrical installations and systems which are energy efficient, while complying with the Indian Standards for the same which provide apart from efficiency, the various other important requirements including relating to performance and safety.

The requirements for energy efficient design of electrical installations in buildings are classified under the following four categories:

- a) Minimizing losses in the power distribution system,
- b) Reduction of losses and energy wastage in the utilization of electrical power,
- c) Reduction of losses due to the associated power quality problems, and
- d) Appropriate metering and energy monitoring facilities.

The active energy efficiency measures include making use of energy saving equipment, low energy lighting, efficient motors, low loss transformers, efficient appliances, suitable power carrying devices and optimized electrical distribution. These active measures along with high efficiency standby emergency generating plants using diesel, natural gas, alternate fuel, etc coupled with high efficiency uninterruptible power supply (UPS) systems contribute towards sustainable development.

Passive features include good practices like simple switching off (to turn off a device when not in use), paying attention to vampire electric loads (associated with electronic appliances like computers), etc.

Some of the recommended design criterions that may be adopted are as follows:

- 1) The transformer selection may be done in accordance with minimum efficiency performance standard (MEPS).
- 2) Higher voltage distribution systems should be employed for high-rise buildings to suit the load centres at various locations.
- 3) The locations of distribution transformers and main LV switch boards should preferably be sited at their load centres.
- 4) To reduce energy losses in the conductors of cable and bus-bar trunking, their appropriate selection should be done based on voltage drop calculations.
- 5) Reduction of energy losses in the conductors of cables and bus-bar trunking may be kept in mind in the choice of conductor cross-section.
- 6) Use of sandwich type bus ducts (stacked configuration) in place of multiple runs of cables and use of dual-bus design with bus coupler is recommended for better fault current withstanding capacity, avoidance of fire hazard, and ensuring higher reliability with low energy loss in the main power distribution system.
- 7) The copper loss of every main circuit connecting the distribution transformer and the main incoming circuit breaker of a LV switchboard should be minimized.
- 8) The effective current-carrying capacity of neutral conductors should have ratings not less than those for the corresponding phase conductors.
- 9) The maximum copper loss in every feeder circuit should not exceed 1.5 percent of the total active power transmitted along the circuit conductors at rated circuit current.
- 10) The maximum copper loss for every single-phase or three-phase final circuit over 32A should not exceed 1.0 percent of the total active power transmitted along the circuit conductors at rated circuit current.
- 11) Any motor control centre (MCC) or motor for air conditioning installations, having an output power of 5 kW or greater, with or without

- variable speed drives, should also be equipped, if necessary, with appropriate power factor correction or harmonic filtering devices to improve the power factor to a minimum of 0.85 and restrict the total harmonic distortion (THD).
- 12) All electrically driven equipment and motors forming part of a vertical transportation system should preferably comply with the energy efficiency requirements for lift and escalator installations.
 - 13) Every motor having an output power of 5 kW or greater may be sized by not more than 125 percent of the anticipated maximum system load unless the load characteristic requires specially high starting torque or frequent starting.
 - 14) A variable speed drive (VSD) shall be employed for motor in a variable flow application.
 - 15) Motor users should insist on appropriate rewinding practices for any rewound motors.
 - 16) Individual power factor correction capacitors should be installed across the terminals of each transformer.
 - 17) The total power factor for any circuit should not be less than 0.85.
 - 18) The power factor correction device should preferably be installed at the source motor control centre or distribution board just upstream of the circuit in question.
 - 19) Office equipments and electrical appliances should have desired energy efficiency levels complying with relevant Indian Standards.
 - 20) Consumers should be encouraged to select and purchase office machinery/equipment, for example personal computers, monitors, printers, photocopiers, facsimile machines, etc, complete with power management/energy saving feature.
 - 21) Consumers should be encouraged to select and purchase energy efficient electrical appliances such as refrigerators, room coolers, washing machines, etc complying with relevant Indian Standards.
 - 22) Designers are encouraged to incorporate into their design all available latest demand side management (DSM) programmes in order to reduce the maximum demand and the electrical energy consumption in buildings.
 - 23) All single-phase loads, especially those with non-linear characteristics, in an electrical installation with a three-phase supply should be evenly and reasonably distributed among the phases.
 - 24) A system approach to measure and verify energy savings in the electrical distribution installations in buildings (specially high rise and commercial ones) should be adopted.
 - 25) Wherever conventional fossil fuel based captive generation systems are deployed scoping for heat recovery systems, including tri-generation, may be explored.
 - 26) To achieve peak demand avoidance programmable logic controller (PLC) controlled automatic electrical distribution systems should be opted for.

11.10 Lighting

Lighting has a significant impact on building loads and energy usage. The lighting design should focus on providing high quality visual environment with an emphasis on energy efficiency. With efficient lighting technologies and moderated interior illuminance, it is possible to design high quality lighting at connected power level that are much lower than that a conventional building. Renewable energy sources should be emphasized for lighting in the outdoor having access to ample sunlight.

11.10.1 Day-lighting and Controls

The optimal use of daylight shall be made to reduce the load of the electric lighting system by dimming or switching off luminaires when natural light provides ample illuminance for the task performed in the space. Daylight harvesting has a significant energy saving potential if it is integrated with the building design after comprehensive understanding of site, building orientation, weather conditions, materials and system design. Design for daylighting shall be done in accordance with the *National Building Code of India: Part 8 Building Services: Section 1 Lighting and Ventilation*.

11.10.2 Artificial Lighting

Lamps, luminaires, ballasts and the controlling systems should be monitored for achieving energy efficiency through artificial lighting. Factors that play crucial role in designing an energy efficient lighting system are:

- a) Reflectance,
- b) Design of interior spaces,
- c) Efficiency of lighting systems,
- d) Task lighting,
- e) Controlling systems, and
- f) Monitoring and maintenance.

Reference may also be made to the National Lighting Code.

11.11 Lifts, Escalators and Travelators

To minimize the environmental impact, the materials used for manufacture of lifts, escalators and travelators should be recyclable, shall not have a potential for depleting ozone layer, shall not be hazardous, and shall be easily disposable at the end of life cycle. As power consumption during utilization phase has the maximum environmental impact, lifts and escalators to be installed shall be energy efficient.

In case of high rise buildings with multiple lifts having peak traffic demand, to increase the efficiency, the destination control system wherein passengers key-in their destination before entering the elevator and which optimizes the number of trips made by the lifts, may be installed. The controller groups the people such that the stops are minimized and travel time reduced.

Electrical traction lifts should be preferred over hydraulic lifts. In addition, the machine used should be energy efficient, such as gearless machine. The motor should be permanent magnet synchronous motor with efficiency not less than 80 percent and

power factor not less than 0.9. The brake liner material should be environment friendly.

It is also recommended to provide lifts with regenerative drives. The efficiency of the drive in both motoring and generating mode should not be less than 0.8. LED lights should be preferred for illumination.

The planning, design and installation of lifts and escalators shall be done in accordance to the *National Building Code of India: Part 8 Building Services: Section 5 Installation of Lifts and Escalators*.

11.12 Good Installation Practices

For installation of equipments and other installations, good installation practices with stringent quality control measures should be followed which also results in easy maintenance and energy saving, subsequently.

11.13 Commissioning and Handing Over

Commissioning is a systematic process to ensure that the installed systems perform according to the design intent and the owner's operational needs. A commissioning plan should be created early in the design phase. The readings should be logged and tabulated properly. The operation and maintenance staff shall be adequately trained by qualified personnel so that the staff has all the information and skill needed to optimally operate and maintain the systems. Operation and maintenance manuals with as-built drawings should be obtained from the contracting agency(ies).

11.14 Operation and Maintenance

The operation and preventive maintenance schedule should be diligently complied with. Operation should be specially focussed, from sustainability point of view, in areas which can result energy saving. Such savings shall be aimed at without compromising the design intent.

11.15 Ongoing Performance

Regular maintenance, required cleaning, periodic calibration, monitoring emissions and leaks, purge operation, record keeping, proper refrigerant levels, etc help in continued peak performance of operation.

11.16 Renewable Energy

All efforts should be made to utilize in the building, the renewable energy available in various forms. Following aspects may be considered for the purpose:

- a) *Solar energy utilization* – Solar energy may be utilized in building through the following applications:

- 1) Solar water heating systems – Hot water requirement in buildings may be met through use of various types of solar water heating systems. Major types of water heating systems are:

- i) Flat plate collector: Single glazed, double glazed;
- ii) Evacuated tube collectors; and
- iii) Water heating with solar concentrators.

Considering the possibility of overcast conditions, or maintenance of collector, etc, the solar water heating system should be fitted with auxiliary heating system using conventional sources of energy such as electricity or gas. Application of auxiliary heating should be determined in such a way to avoid heating of excess amount of water. For example, if the heating is provided in a tank, it keeps the entire amount of water at the set point temperature, irrespective of the requirement/usage, resulting in wastage of energy.

In case of buildings where roof area is not sufficient to cover entire requirement of solar water heating, specially in case of high rise buildings, solar concentrators may be used for focusing solar energy over smaller area.

Decision about single glazed, double glazed, evacuated tube, concentrating type, etc shall be done as per the local site conditions, solar radiation, ambient temperature, wind velocity, shading of neighbouring buildings and other similar features.

Capacity of such systems should be determined as per the average requirement instead of peak requirement, as the later increases the investment involved and reduces the financial payback period.

- 2) *Solar steam systems for cooking, laundry, etc* – Steam can be generated on the roof top of buildings through use of solar concentrators. Steam generated through such concentrators can be used to meet requirement of steam in buildings such as for cooking and laundry, and to meet the energy demand for other applications such as for heating/pre-heating of air and disinfection/sterilization of instruments. Specifications of such systems shall be determined according to availability of solar radiation, size and concentration ratio of the concentrator, ambient temperature, steam storage for operation during off-sunshine hours. Wherever such systems are used/installed, attempts should also be made to recover condensate or warm water after its application.
- 3) *Solar assisted refrigeration/air conditioning systems* – It should be also attempted to utilize solar energy to operate vapour absorption or vapour adsorption based refrigeration/air-conditioning systems. Similar to solar water heating systems, such systems may also be designed with auxiliary heat supply provisions so that they may also operate during overcast days.

- 4) *Solar Photovoltaic Systems* – Solar photovoltaic (PV) systems are direct energy conversion systems that convert solar radiation into electric energy. Roof of buildings as well as other exposed areas such as of parking shade, can be installed with solar PV system. Major considerations while designing a building integrated PV system are:
- i) Sufficient spacing between consecutive rows of modules as per the sun-path diagram;
 - ii) Inclination of modules to match requirements as per latitude;
 - iii) Periodic cleaning of dust from the cover of modules;
 - iv) Matching of specifications of PV modules, array, power conditioning unit (PCU)/inverter, battery storage and wiring; and
 - v) Checking of operating point of PCU/inverter, depth of discharge of batteries.

Components of solar PV systems and factors of performance are as follows:

- *PV modules* – These contain solar cells. Efficiency of cells and module should be as high as possible. Currently, cells having 16 percent efficiency are commonly used and suggested.
 - *Charge controller/inverter/PCU* – It is part of PV system that matches the output of PV modules with acceptable form of electricity by battery bank or load or grid. Since considerable power loss may take place in this unit, efficiency of inverter/PCU should be more than 90 percent at full load and not less than 85 percent at 25 percent load.
 - *Battery bank* – It is where energy can be stored in batteries for use during off-sunshine hours. When operating in stand-alone mode, usually additional one day energy storage capacity is provided in the battery bank. Location and type of batteries should be such that they do not affect indoor air quality. If kept indoor, the space should be sufficiently ventilated with fresh air with no recirculation of air.
- b) *Wind energy utilization* – If sufficient wind velocity exists at the site, it should be attempted to make use of available wind velocity through installing wind turbine for power generation. Usually wind velocity increases with height, hence wind turbines may be installed on the roof of high rise buildings or between two buildings causing venturi effect due to their shapes, with due care towards structural safety considerations. Hourly wind data of whole year at the site should be the basis of machine selection, and not just wind velocity during few days of the year.

Annual power output from the turbine should be more than power output equivalent to full load output for 20 percent of the whole year. However, exact

number in this regard shall be governed by the cost of wind turbine, cost of electricity and other case specific variables.

The visual disturbance caused by the rotating wind turbine, acoustic disturbance to neighbouring area and to occupants of buildings should be considered while selecting machine and its location.

At some locations where wind and solar radiation both are available, and specially when wind is available during the time when there is no or less solar radiation, hybrid wind-solar PV systems can also be considered. Wind-energy systems may also be operated in hybrid mode with other sources of electricity such as diesel generating (DG) sets to ensure availability of power throughout the year.

- c) *Waste Utilization* – It should be attempted to make full utilization of all wastes, specially waste heat and bio-degradable solid waste.
- 1) *Waste heat utilization* – Waste heat available from different sources such as exhaust gases and cooling water of electricity generators, or any other process going on in the building that discharges solid, liquid or gaseous hot waste, may be utilized directly through heat recovery methods for heating applications such as space heating, service hot water, etc. Alternatively, the waste heat available can also be utilized for operating vapour absorption or vapour adsorption refrigeration/air-conditioning systems.
 - 2) *Solid Waste Utilization* - Bio-degradable solid waste generated within the building, such as kitchen waste, human excreta, branches and leaves of trees, grass cuttings should be utilized through anaerobic digestion process to produce combustible gas. This gas may be utilized to replace some fuel requirement in the building. Manure is a by-product of such bio-gas digester that may be used to improve the economics of utilizing solid waste. Other alternatives of anaerobic digestion, such as briquetting for direct combustion, gasification may also be used as per properties and availability of solid waste.
- d) *Bio-Fuels* – The term bio-diesel or bio-fuels is usually referred to liquid fuels that are not obtained from fossil based sources of energy such as crude oil, but are obtained from plant species.

In case of buildings where open space is available, attempts should be made to grow such plants and use their oil to substitute some of the conventional fuel. For example, DG sets may use a blend of bio-diesel and diesel or may even operate on 100 percent bio-diesel.

Similarly, other possibilities of obtaining combustible fuel, such as from vegetable waste oil of restaurants and hotels should also be explored and utilized, wherever possible.

- e) *Hydropower* – The flow of tides of an ocean or a stream is harvested to produce hydropower. As the water is released from the upper reservoir to the lower reservoir it generates power using the hydro-kinetic energy of the water flowing through a generator. The ability to use hydropower is limited on an individual building scale. On rare occasions, buildings can take advantage of streams to generate hydropower on site.
- f) *Other Renewable Energy Sources* – Depending upon climatic location and site specific features, possibility of exploiting other renewable energy sources as geothermal heating and cooling systems should also be considered.

12 CONSTRUCTIONAL PRACTICES

The framework for sustainable construction practices includes the following issues:

- a) Pre-construction pre-requisites;
- b) Planning for sustainable construction;
- c) Preparation of sustainable construction management plan;
- d) Planning, monitoring and control of environmental descriptors;
- e) Sustainable work execution procedures;
- f) Effective use of water;
- g) Construction waste management ;
- h) Post-construction closeout;
- i) Construction methodology for heritage buildings; and
- j) Alternative use, de-construction, dismantling, demolition.

12.1 Pre-Construction Pre-requisites

Sustainable construction bears upon developing the design proposal, which is efficient in terms of functional performance as well as detailed out to ensure that the material resources and construction technologies are used efficiently during construction stage. Frequent changes to the design during construction stage often lead to wastage and other resources, rework and redundant handling and construction processes. Construction practices to execute design proposals, which inherently cause higher wastages and do not facilitate efficient planning should be avoided. The pre-construction stage proposal development should incorporate certain pre-requisites that lead to sustainable construction practices.

12.1.1 Architectural and structural Design

Architectural design should be detailed out so that use of materials and technologies may be planned in advance. Design detailing should facilitate planning of procurement of materials in sizes, volumes and lots, such that the wastage during construction is least. It is desirable that the design is consistent with the available material sizes, shapes and volumes. Design should, therefore coordinate to incorporate quality and quantity aspects from the point of view of construction.

Design detailing should facilitate procurement process. Storage of materials at site for unduly long period may adversely affect its quality and short supply may lead to

interruptions in interfacing activities. Thus, the efficient procurement process ensures optimum procurement.

Structural design is critical in ensuring optimum use of materials. Inadequate rigor in design analysis can lead to over-sizing of structural members, while uncertain quality assurance and control may render structural members unsuitable due to permanent construction defects.

It may be desirable to develop building designs through digital models so that the dimensional coordination and interfacing between architectural, structural and engineering services is ensured with an aim to avoid improper execution during construction stage. Application of 'modular coordination' is desirable in mass repetitive construction works especially using mechanized or industrialized construction techniques.

Drawings generated as 'good for construction' must be reviewed for coordination coordinated across various disciplines before their release for construction. Coordination between architectural drawings, structural drawings and engineering services (mechanical, electrical, plumbing) drawings, etc shall be assessed in plans and sectional details. It may be desirable to undertake three-dimensional clash analysis using appropriate information technology tools and software. Therefore, all efforts should be made at design stage to ensure that the time and resources are not wasted during construction stage work.

12.1.1 *Inclusion of Sustainable Construction Needs in Feasibility Report*

Feasibility report directs planning, design and execution of a project. It acts as a reference boundary for the project within which the project is viable. It details out the manner in which objectives of the project are achieved. Project requirements shall be accomplished within the planned resources. In light of the significance of feasibility report, it is essential that the sustainability objectives, both in terms of operational phase of the project as well as the construction phase, should be highlighted. As a result of that, the resources, technical procedures and benchmarks may be established for execution to be viable within the overall sustainability parameters of the project.

Specifically, benchmarks for the energy consumption, water utilization, waste generation, reuse of waste generated during construction and operation phase should be established in the feasibility report for sustainable construction.

12.1.3 *Construction Methodology*

For sustainable construction practice, it is essential that the physical execution of works should only be undertaken when the construction methodology is established, and reviewed for its reliability under the risk environment that may prevail under specific conditions of the project. Construction methodology details out process of execution, its work flow, deployment of various resources, planning for eventualities and contingency measures. In absence of an established sustainable construction methodology, the efficacy of work procedures may not be ensured.

It is desirable to evolve construction methodology on digital models so the physical developments at site may be simulated under working conditions. Information tools that identify inter-disciplinary clashes are identified. In many a cases, it may be necessary to plan in a predetermined manner for the structural considerations, failing which the stability may be jeopardized. It is essential for construction works that involve a fair amount of pre-fabrication, especially off-site, so that the fabrication is compatible and the installation procedures are fail-safe during the installation as well until the stage when structure is capable to endure itself independently.

12.1.4 Mitigation of Impacts Due to Materials and Technologies Deployed

Construction materials and technologies used at site may impact the environment, specially during processing of materials, such as cutting, mixing, fabrication, etc causing noise, dust and sometimes release of fumes. Such materials and technologies need to be identified and procedures planned to mitigate impacts.

12.1.5 Deployment of Plants, Equipments and Machineries

Selection of efficient plants, equipments and machineries and their proper scheduling of operation are key considerations for sustainable deployment. While selection, it is essential to ensure that plants, equipments and machineries have their performance ensured not in isolation but also when considered in relation to the supporting plants, equipments and machineries. For example, the selection of excavator of a certain capacity is linked to the availability to earth transportation out of site and the clear working space available for the excavator and the transportation vehicles. Having selected an optimum set of plants, equipments and machineries, it is essential that their operation is scheduled such that their combined performance is maximized. Failure to deploy plants, equipments and machineries in an efficient and effective manner may result in undesirable loss of fuel and consequent noise and air pollution.

12.1.6 Procurement Policy

In order to ensure sustainable construction, the organizations involved should have a resolve and commitment to procure processes, services, works and supplies of that help in achieving the objective of sustainability. Since sustainability is project and context specific, the policy should entail requirements in respect of sustainability pertinent to the project.

12.1.7 Contractual Obligations towards Sustainable Construction

Contracts determine obligations of individuals and organizations. In this respect, therefore, the contracts shall make it obligatory on the part of the supplier (work, services or supplies) to follow sustainable practices and processes. The scope of such obligations shall include the relevant issues described under **12** of this Part. in this section. Contractually binding obligations ensure system-wide responsibilities so that necessary mitigation resources may be budgeted within the project scope.

12.1.8 Assignment of Responsibility for Sustainability Practices during Construction

The responsibility for sustainability practices during construction shall be clearly assigned, also explicitly assigning liabilities that may accrue on account of lapses. This strengthens the responsibility delegation and also act as deterrent for slackness while discharging duties. Liabilities may include contingencies for risks known as well as management reserves towards unknown risks.

12.2 Planning for Construction

Pre-construction pre-requisites are important inputs to the planning for construction in a sustainable manner. Planning processes describe the approach towards the construction. A proper planning, considering peculiarities of project, helps ensure successful execution. The planned processes towards sustainable construction may be far more effective than spontaneous actions taken without comprehensive planning at early stages. Also, cost for mitigations and possible alternative strategies for mitigation may be better analyzed for arriving at managerial decisions.

12.2.1 Identification of Sustainability Issues during Construction

The procedure to identify sustainability issues during construction, should include the areas of analysis given in **12.2.1.1** to **12.2.1.5** and other applicable concerns in respect of project scope and context of site and environment.

12.2.1.1 Construction methods review and impact on sustainability

Design details determine the construction procedures. It is desirable to prepare a construction methodology and review the same from the point of view of its impact on the suitability to achieve quality, control of wastages, safety, resource optimization, energy conservation, water use, site contamination and pollution.

12.2.1.2 Consideration to environmental impact assessment

Environmental Impact Assessment (EIA) report systematically identifies the risks and impacts and recommends mitigation measures. Framework of EIA is defined in accordance with the statutory requirements and, hence, it is essential to consider the impacts so identified. Construction methodology and processes shall take cognizance of EIA report and Environmental management plan (EMP).

12.2.1.3 Considerations to social impact assessment

Construction activities have significant impact on the socio-cultural interests of the populations surrounding the project sites. Continuance of human activities, especially related to their economic sustenance, livelihood and socio-cultural aspects, need special sensitivity. Dealing with social impacts during construction stage need managerial decisions to provide privileges to the affected populations and undertake actions to contribute towards deployment of social infrastructure. Such initiatives should be planned for.

12.2.1.4 Prevention and management of construction disasters

Disasters shall be prevented during construction stage. Construction teams shall analyze potential hazards and plan for their prevention and management during disasters. Disasters endanger life of workers and populations in and around the sites, cause disruptions to work, lead to loss of material and other resources. Efforts in prevention of disasters is often insignificant as compared to the problems in facing consequences. Deep excavation, scaffolds, shuttering and hoisting operations are known to cause disasters at sites. In addition to the disasters that may be caused due to the activities on site, there may be environmental conditions that may cause disasters during construction works since works may not have attained the stage of adequate stability and endurance to counter the impinging environmental conditions. Floods, landslides, cyclones, high winds and earthquakes may need special attention for disaster preparedness.

12.2.1.5 Identification of training needs and workforce training

Sustainable construction practices require specific processes to be followed in respect of planning, monitoring and control. Involvement of workforce at all levels need training to deal with sustainability issues during construction. Project management functional responsibilities shall include identification of processes, competencies of persons involved in discharge of such duties, assessment of performance and conduct training program. The effectiveness of training programme shall be assessed through performance appraisal system and corrections made as needed. Training need assessment frequency should be determined based on the type of work and the human resource competencies.

12.3 Preparation of Construction Management Plan

Having identified sustainable issues specific to the project, a comprehensive planning needs to be documented in a management plan. The Management plan documents the approach to site management, project management processes, systems for management, site organization, data inputs to determine effectiveness of management systems and site planning.

12.3.1 Establishment of Construction Project Management Processes

Objectives of sustainable construction can only be realized through effective project management processes. Time, cost, quality, scope, risk, procurement, human resource, health and safety are some of the basic project management processes that shall be elaborated. Reference should be made to good practices [11(29)] for detailing out construction project management processes.

12.3.2 Establishment of Management Systems

Management systems define organizational commitment, organizational structure, resource allocation, relevant critical planned processes, procedures for monitoring and control to ensure continual improvement. The approach of management systems is preventive with an objective to achieve excellence in terms of absence of

non-conforming works. Management systems approach sustains on documented voluntary initiatives due monitoring thereof, and the same way be considered,

Reference should be made to appropriate Indian Standards for developing and complying the above systems.

12.3.3 *Establishing Site Organization Structure*

Establishing site organization structure, considering management systems and involvement of other agencies in construction, is very critical. Interfaces across various agencies involved in construction need clarity for effective coordinated decisions which can lead to prevention of wastage of resources, reworks, rejections, delays and such other non-conformities detrimental to quality of work.

12.3.4 *Establishing Energy Consumption Data Collection, Analysis, Documentation System and Creating Benchmarks*

Monitoring of performance of management systems and processes of execution need establishment of indicators so that specific improvements may be achieved. In this respect, energy consumption monitoring is fundamental. At construction sites, electricity and diesel are primary sources of energy and their consumption shall be monitored so as to improve methods and the operation of equipments is energy efficient. Data collected should be analyzed with respect to processes of significance in terms of consumption and pollution. Database so generated can also be used for establishing project specific, organization specific or process specific benchmarks for future reference. Appropriate documentation of fuel consumption logs, energy metering and execution processes shall be planned and assigned organizational responsibility. Site management decisions shall take cognizance of energy consumption data.

12.3.5 *Overall Construction Site Planning*

Improper site planning is often reason for redundant material handling, processes involving unnecessarily long lead, wastage during multiple handling, inefficient deployment of equipments, etc. Circulation and movement of workers and visitors can be reason for unsafe working conditions. Following issues, therefore, need specific attention while undertaking site planning.

- a) Layout of roads and services;
- b) Deployment of plants, equipments and machineries;
- c) Location of temporary structures, fabrication area and storage areas;
- d) Work area demarcation and safe surrounding;
- e) Emergency plan and medical facility;
- f) Control of site dereliction;
- g) Prevention and management of top soil; and
- h) Storage of chemicals, fuels and explosives.

12.3.6 *Location of Infrastructure for Labourers*

Labour is at the bottom of the organizational structure of construction practices. Project organizations may tend to ignore the interests of labour and tend to be indifferent to their needs. Indifferent and ignored labour, on the other hand, can cause inherent inefficiencies in the system and lead to unreliable performance. Infrastructure for labour needs to be planned and budgeted suitably considering the following:

- a) Policy and location of labour camps;
- b) Policy for deployment of labour from local communities;
- c) Labour movement;
- d) Social infrastructure for labour;
- e) Health, hygiene, amenities and waste disposal ; and
- f) Training need assessment, training infrastructure and effectiveness monitoring.

12.3.7 *Setting Up of Health and Hygiene Infrastructure*

Health and hygiene infrastructure is needed for the construction site as well and the labour infrastructure, specially if labour camps are off site. In addition to the construction project specific injury and emergency treatment facilities, facilities shall be provided for conducting periodic health check ups for the workers so that the effects of construction activities on the health are monitored. Medical facilities shall be established with suitable expert physicians and paramedics, availability of appropriate medicine supplies, diagnostic facilities and organized record keeping.

As a part of hygiene infrastructure, potable water supply, waste water disposal and solid waste disposal (non-construction) are planned in a proper manner. In order to determine the standards, the needs of vulnerable groups, such as children, shall be considered.

12.3.8 *Location of Facilities for Hazardous Materials*

In special cases, the facilities for hazardous materials may be provided very carefully. There may be a case for locating such facilities off-site. Specific statutory guidelines in respect of such requirements shall be referred to. The facilities and the handling procedures shall be well established.

12.4 Planning, Monitoring and Control of Environmental Descriptors

Environmental impact assessment (EIA) undertakes characterization of the existing status of the land, water, air, biological and socio-economic environment in the project area and its surroundings. It seeks to identify potential environmental impacts of the project, and formulation of an effective environmental management plan (EMP) to prevent, control and mitigate the adverse environmental impacts, and ensuring the compliance with the environmental legislations. Thus, the scope for planning, monitoring and control of environmental descriptors during construction phase is identified and described in the EIA and EMP. Construction agencies shall develop further and detail out their respective compliance requirements accordingly.

Depending on the nature of project, construction agencies shall be required to establish infrastructure and procedures for soil monitoring, water quality monitoring, ambient air quality monitoring, noise monitoring, tree counting and traffic survey, with a view to required controls thereon.

12.4.1 Soil Monitoring

Soil samples from representative locations in the site and study area shall be collected and analysed for important relevant physical and chemical parameters. Soil monitoring should be carried out in at least three locations including one at the project site.

12.4.2 Water Quality Monitoring

Water quality monitoring shall be conducted at representative locations in the study area for surface and ground water. Samples shall to be collected and analysed for important relevant physical, chemical and bacteriological parameters. Water quality monitoring locations should include at least three surface water (if exists in the study area) and three groundwater locations.

12.4.3 Ambient Air Quality Monitoring

Ambient air quality in respect of suspended particulate matter (SPM), respirable particulate matter (RPM), SO₂, NO_x, and CO, shall be monitored at representative locations in the site and study area at a frequency of twice a week at each location adopting a 24-hourly schedule (8-hourly for CO). The monitoring locations shall be located on the basis of predominant wind directions, land use pattern and height of the proposed stacks. At least one station shall be located at the maximum pollution deposition area due to the proposed stacks of generators. The number of air quality monitoring locations should be at least five including one at the project site.

12.4.4 Noise Monitoring

Ambient noise level monitoring shall be carried out at representative locations in the site and study area over a period of 24 h to obtain hourly equivalent continuous noise (L_{eq}) levels as well as day and night time L_{eq} to compare with the standards. Noise monitoring should be carried out for at least six locations including one at the project site, one at the boundary of the project site and one at the nearest residential/sensitive area.

12.4.5 Tree Counting

Survey shall be conducted to assess existing trees in the project site in respect of numbers, species and girth size.

12.4.6 Traffic Survey

Traffic survey for continuous 24 h has to be carried out to measure number and type of vehicles passing on the existing main roads giving access to the project.

12.5 Work Execution Procedures

Work execution procedures should be described in a manner so that there is least wastage, rework and repair and acceptable performance is achieved. In this respect, the reference to relevant Indian standards for materials and completed works; quality assurance verification; material handling, storage, and protection; work procedures including working on materials/fabrication, placing/installation; inspection and testing procedures; and protection after completion of work, need to be specifically addressed. In addition to these considerations, the relevant works should be specific attention as given below:

- a) *Excavation and Sub-structure Works* – Issues related to noise and vibrations during excavation, piling, rock cutting, etc; control of damages to surroundings; prevention of collapse; and, control of excessive dewatering and sustainable use of de-watered water need to analyzed, risks identified and methodologies detailed out prior to undertaking such works.
- b) *Concrete Work Procedures* – Soundness and stability of formwork and other enabling structures; suitability of concrete mix to the prevailing environmental conditions; avoidance to undesirable cutting, etc for laying services and embedded items; providing requisite cover to the reinforcements; proper curing; and, allowance of setting time are essential for meeting the expected performance of concrete works. In general, for concrete works, good practices [11(30)] shall be followed.
- c) *Steel, Aluminium and other Metal Works* – Noise control during cutting, welding, hammering and fabrication operations; prevention of waste; reuse of cut metal sections (for example cut reinforcement bars reused in other locations depending on requirement); collection and disposal of scrap; fire and injury prevention during welding; prevention of collapse due to unstable installation operations; and safety of workmen are critical aspects that need special mention in procedures.
- d) *Masonry Works* – Wastage during on-site handling of materials; execution in proper plumb, plane and alignment to avoid wastage of finishing material for making up for the defects; and, filling up of joints to attain requisite *U* and *R*-value characteristics need particular attention.
- e) *Surface Finishing and Furnishing* – Preparation of finishing base; environmental conditions during and after finishing/furnishing works; and, application procedure for surface undulations are essential considerations to realize desirable surface characteristics as well as service life of finishes and furnishings.
- f) *Handling and Use of Chemicals* – Working conforming to the prescribed procedures; protection against spillage and human body contact; supply and use log describing quantities and authorized person(s); and, prevention of reaction which are explosive, exothermic causing fire or

release of toxic fumes or creating corrosive reactions to the surrounding works, should be specifically identified and planned.

- g) *Handling and Use of Oils* – Avoidance of fire by preventing conditions leading to ignition; spillage polluting the works and sites; use of appropriate containers for storage and handling; and contingency procedures for limiting damage due to spillage and neutralizing the effects should be specifically highlighted in procedures.

12.6 Effective Use of Water - Refer 10.4.

12.7 Construction Waste Management

12.7.1 Construction and demolition activities generate large quantities of solid waste. Diversion to landfill sites is one of the major issues in handling of construction waste. Increase in waste generation and improper land filling with construction wastes have major impacts like ground water pollution through leaching. Construction organizations shall systematically pre-empt and identify wastes that may be generated and plan to re-use, re-cycle and handle wastes in an appropriate manner. Monitoring of waste and its disposal through an established procedure also create opportunities to prevent wastages in construction processes and lead to conservation of resources.

By proper disposal, waste materials which are likely to be dumped in landfills can be converted into value added products. Some construction waste materials can be diverted product for re-use, whereas others can be recycled into another usable material. Many construction waste materials can either be used onsite or sent to other sites/industries for reuse/recycle/reconversion into useful products.

One of the important approaches to reduce waste and effect waste utilization is to evolve design details such as optimizing use of materials and employing technologies aiding in the same. Durable materials and high performance technologies need lesser maintenance and deliver better service life. Proper construction waste planning is, therefore, recommended before starting the construction or demolition which involves identification, segregation, proper storage, reuse/recycling and finally the proper disposal of remnant waste materials.

12.7.2 *Identification, Segregation and Storage of wastes*

It is very difficult and costly to reuse or recycle the waste materials which is in mixed form and not segregated at right time during the construction. Storing of segregated waste in labelled containers/bins, and monitoring of stored waste bins periodically by the trained/skilled personnel may prevent wastage. Waste should be stored within the site and such area should be chosen where further shifting is not required.

12.7.3 *Reuse and Recycling*

Reuse and recycling not only reduces the land filling load but is also economical and eco-friendly step in construction. Reuse increases the life of building materials. It is

desirable to locate nearby recycling units for construction waste recycling to reduce the cost as well as adverse environmental impact.

Brick bats and concrete, especially from piling works, have a potential to be used as sub-grade works for paving, etc. Excavated earth and boulders may often be reused at site or used elsewhere through the network of specialist agencies. However, topsoil should be isolated, preserved and reused at the same site or at another location where there is a demand for fertile topsoil for landscaping. Wastes, such as metal and plastics, should be disposed off for re-cycling. Other wastes, such as cellulosic materials, timber, etc that are biodegradable, should be disposed off at authorized designated locations.

12.7.4 Handling and Disposal of waste

All construction wastes shall be stored or handled in such a way so as to avoid unnecessary decay or deterioration. Bio-degradable waste during construction shall be collected separately and treated with bio-methanation, organic waste compactors, etc or subjected to composting.

Construction waste is generally inert in nature (does not contain chemical or biochemical pollution), but proper training is required to handle the construction waste because improper handling may cause accidental damage to the handling person. The person segregating the construction waste should be properly equipped for safety aspects. Spillage of construction waste during transportation should be prevented. There are different sustainable techniques of waste disposal available and should be practiced.

12.8 Post-Construction Closeout

Project closeout is a very significant stage from the sustainability considerations. While project management closeout should ensure that the contractual obligations are complied with, the consequences of construction activities should also be appropriately determined. At this stage, the obligations of the project, in terms of physical delivery of works as enshrined in the briefing documents as well as environmental commitments towards sustainability, shall be ensured.

12.8.1 Disposal of Structures and Infrastructure for Construction

Building and other structures and other infrastructures may need to be demolished/reconstructed partly or completely. These including their mechanical, electrical, plumbing installations, etc may have to be disposed off in a manner so as to facilitate re-use of materials, components, installations, etc by the same organization at another construction site or their re-cycle. In case the materials do not have re-claim value, possibility should be explored for their use as backfill materials; otherwise off site disposal may be resorted to in an appropriate and authorized manner.

12.8.2 Closure of Tube Wells

Abandoned tube wells are a risk to life. These shall be closed properly. In may also be explored to reuse the same as a part of water harvesting system.

12.8.3 Restoration of Dereliction Caused to Site

While controlled site dereliction is a good construction practice, the site should be restored deploying appropriate methods. Project budget should include apportionment of resources towards restoration. Such restoration activities may continue for a long time even after physical completion of project, and hence, the commitment towards such efforts is essential. It shall be ensured that the areas, which are under restoration, are well protected during this period.

12.8.4 Re-use of Top Soil

Re-use of top soil as a resource is an important sustainability consideration. In case the construction site does not leave adequate space for storage of top soil, it is important to identify another location in vicinity for proper storage until it can be reused at the same site or in case it is found not possible to use in the same site, it is taken to other nearby site for use as top soil. Value of top soil should not be compared in financial terms but rather as a scarce natural resource.

12.9 Heritage Buildings and New Construction

Heritage buildings should be given special attention during construction of a new building, specially if it is situated in close vicinity, complying with the requirements of proper architectural controls in accordance with **18** of *National Building Code of India: Part 2 Administration*. The following may also be considered while planning and executing such works:

- a) Heritage contents, their characteristics and other building elements that need to be undertaken as scope of work
- b) Construction techniques including diversion of utility services
- c) Competence and experience of execution agency to handle such works involving the use of traditional materials and technologies
- d) Approval of structural and chemical investigation and local understanding, of the heritage structure if it has merit of cultural significance.
- e) Project management processes especially pertaining to time, cost, procurement and risk assessment, risk management and risk preparedness strategy, using the sequences appropriate to traditional works.
- f) Scheduling of activities including review processes and inspections by designated competent persons
- g) Planning for enabling works and safety such as scaffolds, protection measures for other adjoining works
- h) Site management including circulation diversions
- i) Contingencies for unexpected damages to works and unforeseen structural behaviour
- j) Prevention of fire, flooding and other such emergencies and disasters during works

12.10 Alternate Use, De-construction, Dismantling and Demolition

Built facilities are created to facilitate certain functions. Due to changes in functional use over a period, deterioration in physical condition of building elements, etc the productivity may decline below threshold. As a result such buildings may be rendered unsuitable in spite of previous renovations. In such situations, effort should be made to re-use of facilities with renovations or remodel for alternate use retaining most of the building and its facilities. Effort may be made to evolve a flexible design so as to make it suitable to varied functional uses.

If design configuration and residual service life is not consistent with functional requirements and particularly considering the safety of the building, the built facility should be de-constructed so as to retrieve as many buildings assemblies/materials/installations for re-use and re-cycle, as possible. While working on design details, it shall be ensured that the design should facilitate deconstruction. During the process of de-construction, least damage should be caused to the assemblies, materials and installations. In case of complex structure, such operations shall be undertaken under expert supervision and with proper enabling works.

If built facilities were not designed to facilitate de-construction, the dismantling should be resorted to in such a manner as to maximize retrieval of materials. Demolition operations shall be planned considering safety of workers; and avoiding Damage to adjoining properties; Noise, vibrations and air pollution; disruption to continuance of activities in the vicinity; etc. The demolition shall be carried out in accordance with good practices [11(31)].

12.11 Disaster Risk Mitigation during Construction

Sustainable construction practices shall address risks during construction stage from natural and man-made disasters. Natural disasters such as earthquakes, landslides, cyclones, flooding, etc shall be considered during construction planning and adequately taken into consideration in risk mitigation through the construction methods statement, generally developed by the construction project management team and/or construction agency. Reference shall also be made to the *National Building Code 2005 of India: Part 6 Structural Design* for technical measures for natural disaster mitigation.

In addition to the natural disasters, the risk mitigation against man-made disasters shall also be carried out. Deep excavations causing cave-in due to the lack of proper protection, earth saturation caused due to leaking city sewers/water mains are common man-made disasters. Similarly, fire collapse of structural slabs leading to progressive collapse of slabs below, hoisting of space frames, trusses and concrete segments and operations involving coordinated lifting/hoisting using multiple cranes are some typical situations that may turn disasters. Such operations and processes should have 'fail-safe' detailing as also back-up plan to deal with disasters. Necessary resource deployment shall be part of such disaster planning.

Reference shall also be made to *National Building Code of India: Part 11 Constructional Practices and Safety* for safety during various construction operations.

13 COMMISSIONING, OPERATION, MAINTENANCE AND BUILDING PERFORMANCE TRACKING

13.1 General

While the guidelines covered for commissioning and handing over, operation and maintenance and building performance tracking are applicable to majority of building occupancy types, many of these are particularly suited to buildings with high energy consumption such as large office buildings, hospitals, hotels, retail malls, etc.

13.2 Commissioning and Handover

Commissioning of building services typically includes natural ventilation, renewable energy systems, metering installation, plumbing and HVAC systems commissioning, etc. Commissioning stage should record the consumption of energy (such as power consumed by fan motors) and water used by plumbing and other systems that will help in reviewing and improving the systems for efficient operation. The commissioning stage helps in identifying any remaining site activities and the training activities that need to be coordinated. It helps in bringing to attention various common problems encountered such as key pieces of hardware are missing, not installed, or defective; installation of sensors, scanners, and other monitoring devices in the wrong locations; and improper coding of the sequence of controls for equipment. These and other problems should be identified and corrected during the commissioning process. Required resources should be allocated to commission the systems after they are installed to ensure that they work as intended. A complete and thorough commissioning of the building shall be done to ensure that the systems will work as intended.

13.2.1 Commissioning Process

Typically, the first step in the commissioning process should involve formation of a commissioning team that comprises the owner, users, occupants, operation and maintenance (O&M) staff, and design professionals and owners. The next step is the preparation of the project requirements, which should address building systems such as lighting, air-conditioning, water systems, etc as well as the design intent and the functional specifications for the key building systems. The project design document should include a commissioning plan. Prior to the handover stage, the commissioning team should verify the installation of the systems, conduct functional performance testing, training of the O&M personnel, etc. A post occupancy commissioning report shall be provided to the owner and/or relevant authorities once the necessary tests have been conducted and the areas that need correction have been rectified.

13.2.2 Handover

During the handover stage, records of meter readings for the different building systems, and other data should be provided to the asset management team. A

simple guide for occupants will help the team understand the working of the systems in the building.

13.3 Operation and Maintenance

O&M programmes that focus on improving energy efficiency of building systems can help save energy without a significant capital investment. From small to large sites, these savings can represent significant savings each year, and can be achieved with minimal cash outlays.

Building maintenance is a wide subject covering not only maintenance of building services but also the maintenance of all other aspects including the structure itself. Effective operation and maintenance is one of the most cost-effective methods for ensuring reliability, safety and efficiency of a building. Inadequate maintenance of energy-using systems is one of the major causes of energy waste. Energy losses from steam, air and water leaks, uninsulated lines, maladjusted or inoperable controls and from poor maintenance are often considerable. Also, inadequate maintenance of systems that consume water, including plumbing and HVAC systems (as applicable), can result in excessive usage of water. Good maintenance practices result in substantial savings in consumption of energy and water, and should be considered as a resource.

Traditionally, O&M is carried out on a reactive basis, where maintenance is only provided when equipment or systems fail. On the contrary, a preventative maintenance program, that prescribes regular checks of equipment at scheduled intervals, helps to improve system performance and extend its useful life. Predictive maintenance programs go a step further where rather than following a set schedule of maintenance, checks are used to predict when equipment may be in need of maintenance prior to it experiencing any damage. Such predictions are based on analysis of known factors, for example 'stressors' that can impact the performance of the system. The O&M plan should be complemented by a review of the building operation with one year after the majority of the building area has been occupied. The design and construction/installation teams should also review the O&M manual with the asset management team.

13.3.1 Requisites of an O&M Program

A competent O&M program requires the participation of staff from operations, maintenance, engineering, training and administration. The successful implementation of an O&M programme requires cooperation, dedication, and participation at all levels including among managers, practitioners, and other technical staff. The O&M plan should be a living document, that is, it is amended as the other requirements change. The intention should be to update O&M document periodically as new procedures and technologies are developed and employed. A web-based version can also be implemented for incorporating updates as frequently as possible.

Revisions to the O&M programme should be considered throughout the assessment process while considering all potential energy savings, and also when capital-

intensive projects are being evaluated. Changes to O&M procedures and practices should be considered beyond the scope of repair and regular maintenance. Auditors who conduct performance review of the facility should take a holistic approach, and should consider:

- a) how the activities that are undertaken within the building can be used to optimize energy efficiency in existing operations, and
- b) how the newly implemented measures can improve the performance of the building.

Activities related to O&M should be included in the implementation plan; responsibilities should be designated to individuals; and time lines should be outlined for completing these activities. Training of the staff and awareness programmes should be developed to ensure that there is full compliance among staff for the new procedures to ensure effective implementation of the energy efficiency programme. The O&M plan should refer to the manufacturer's recommendations on equipment operation and maintenance. O&M actions and activities should only be carried out by trained personnel.

13.4 Building Performance Tracking (Measurement and Verification)

Subsequent to the commissioning and handover stage, regular monitoring of the performance shall be carried out which will provide information on whether the set environmental performance and targets have been met or not. As part of the measurement and verification (M&V) process, an ongoing monitoring of the energy and water systems should be carried out. This will ensure ongoing accountability of energy and water consumption during the life of building. Some of the main attributes of a building performance tracking (measurement and verification) system include:

- a) Monitoring of technical and energy performance during first three to five years of occupancy, to ensure that the performance targets during the operation of the building are in line with the expected performance parameters. Energy metering may be provided for the following applications:
 - 1) Lighting (interior and exterior);
 - 2) Air conditioning (heating/cooling);
 - 3) Hot water systems;
 - 4) Renewable energy systems;
 - 5) Energy meters for pumping of municipal water, grey water and irrigation water;
 - 6) Miscellaneous equipment such as elevators, computers escalators; etc.
- b) Conducting an occupant survey annually for the first three years of the building. This will help in obtaining feedback from the users regarding the effectiveness of the designed systems, as well as identifying possible areas of improvement. These survey will also provide information about any enhancements or modifications.

Monitoring the performance of plumbing, sanitation and irrigation systems in terms of the water consumed when the building is in operation is an important aspect of the performance tracking system. Metering the water consumed by these systems will help in determining whether the water consumption by the building is in an efficient manner or not. Similarly, measuring and tracking the discharge of water by the building, whether it is storm water, sewage, or otherwise, will provide information on whether the re-use of water is taking place efficiently or not. Refer **10** for design of water efficient systems.

An energy management and control system (EMCS) is one method of tracking the performance of the energy consumed by the different building systems. EMCS systems typically consist of electronic devices with microprocessors and communication capabilities and utilize widespread use of powerful, low-cost microprocessors and standard cabling communication protocols. EMCS provides a building operator, manager or engineer with basic background information and recommended functions, capabilities, and best practices that will enable the control systems to be fully optimized, resulting in improved quality of life of building occupants and users and more reliable and energy efficient facilities.

13.4.1 Functions and Capabilities of an EMCS

An EMCS may be known as building automation system (BAS), building management system (BMS), energy management system (EMS), and facility management system (FMS). In this Part of the Code, the EMCS referred comprises the sensors, transmitters, data acquisition and data processing performed at the user (building) level as well as data and control systems that are more global to full campus control schemes. EMCS may also have a global supervisory controller to perform high-level tasks (for example, resetting temperature set-points based on building conditions and scheduling on/off times). The hardware generally consists of a distributed computer environment with smart controllers strategically located throughout the system (buildings and base-wide network). Several network terminals or computers can be attached to these networks to provide a man-machine interface (MMI).

Depending on its capabilities, EMCS can perform a wide variety of functions. At a minimum, the EMCS has a sensor(s) to measure control variable(s) (for example, temperature and flow rates), a controller with the capability to perform logical operations and produce control outputs, and a controlled device(s) that accepts the control signals and perform actions (for example, move dampers and valves).

13.5 Operator Skills and Training

Performance problems result from errors in installation and operation of complex building heating/cooling and other systems. Without the right skill sets and proper training, building operators and managers may not be able to manage the facility optimally even with the most advanced building management systems. One of the key ways to enhance building operations and maintenance performance and thereby achieving the efficiency goals of buildings/facilities is handling by well trained

building operators and managers. To operate buildings efficiently, in addition to a good controls infrastructure, the following may be desirable:

- a) Increasing the skill level of operators and maintenance personnel; this can be accomplished by providing the building operators with frequent proper training and incentives for performing well.
- b) Providing adequate engineering supervision of work by technicians to ensure that knowledge of fundamental processes is properly applied for operation and maintenance actions.
- c) Providing operators with system performance feedback; this can be achieved by providing easy-to-use system diagnostic information to correct problems and to understand the cost impacts of improper operations.
- d) Providing incentives for achieving efficiency goals.
- e) Educating everyone who influences the decisions relating to planning, budget, design, and procurement of energy and related systems.

13.6 Control-System Maintenance

Maintenance of the control system is critical in ensuring its performance after installation and commissioning. Many factors can cause degradation of the control systems performance post-commissioning such as:

- a) Overrides of automatic control by operations staff, a frequent problem, generally driven by customer complaints;
- b) Drift or failure of sensors;
- c) Failure of actuators;
- d) Corroded or failed wires and their connections;
- e) Improper changes to control schedules (sometimes temporary changes become permanent changes by oversight); and
- f) Degradation or failure of controlled devices.

These problems can be prevented by good operation and maintenance practices, such as a reporting system for all overrides, periodic re-commissioning of the control system, and maintenance of the control system and the physical components it actuates. Automated fault detection and diagnostic tools, alarms, plots of trend data, and maintenance tracking systems may be used to help in identifying performance degradation, faults and the need for maintenance and for compliance of recommendations of these tools and taking action, by the maintenance personnel.

It is recommended that the control system specifications include requirements for maintenance documents and a maintenance plan. The facility should also consider contracting for maintenance support if it is not provided in-house. In procuring maintenance support, the organization should ensure that the maintenance contract requires maintenance of all systems in a manner that ensures continuous, or nearly continuous proper operation of all controls and controlled devices. This requires frequent, periodic inspection, testing, and evaluation of systems and equipment followed by the correction of any defects found. System inspection, testing and evaluation can be automated *via* continuous monitoring tools.

ANNEX A (Clause 8.1)

DESIGN STRATEGIES AS PER CLIMATE ZONES FOR VARIOUS SEASONS

Summer period

Necessitates	Hot Dry Climate	Warm Humid Climate	Moderate Climate	Composite Climate	Cold Climate
Reduction in the ingress of heat during the day (by insulation, thermal mass, buffer spaces, orientation, shading, etc).	√	√	√	√	√
Introduction of naturally (through use of courtyard, wind towers, properly positioned windows, etc) or mechanically pre-cooled air, into the building with adequate air-flow during the day	√	√ (substantive increase recommended)		√	√
Adequacy of airflow of naturally (through the use of courtyard, wind towers, properly positioned windows, etc) or mechanically pre-cooled air during the night.	√	√(substantive increase recommended)	√(naturally only)	√	√
Reduction of the temperature variation within the building during the day/night, in comparison to temperature variation in the ambient temperature.	√			√	√
Adequacy air changes, as required by the activities within building, and the density of the occupancy.	√	√(substantive increase recommended)	√	√	√

Winter period

Necessitates	Hot Dry Climate	Warm Humid Climate	Moderate Climate	Composite Climate	Cold Climate
Reduction in the ingress of cold into the building during the day, as well as during the night (by insulation, buffer spaces, orientation, weather stripping, etc).	√	√		√	√ (substantive reduction recommended)
Reduction in the air changes, without compromising with the minimum requirements for the activities, as well as for the density of the occupancy.	√		√		√(substantive reduction recommended)
Reduction in the egress of heat from within the building spaces during the day as well as during the night.	√			√	√(substantive reduction recommended)
Adequacy of natural ventilation/air changes in all spaces, as per requirement of maintaining indoor air quality		√		√	

Marginal reduction in the ingress of cold into the building during the day as well as during the night.			√		

Monsoon period

Necessitates	Hot Dry Climate	Warm Humid Climate	Moderate Climate	Composite Climate	Cold Climate
Reduction in the ingress of heat from outside into the building (by insulation, thermal mass, buffer spaces, orientation, shading etc).	√	√	√	√	√
Substantive increase in the airflow/velocity/air changes during the day as well as the night.	√	√	√	√	√
Reduction of humidity within the building throughout the day and night (using dehumidifiers, desiccant cooling, etc)	√	√	√	√	√
Substantive increase in the natural ventilations in all spaces.		√			

ANNEX B

[Clause 8.2(a) C-1 and D-1]

PRESCRIPTIVE METHOD FOR ENVELOPE OPTIMIZATION**B-1 ROOFS**

Roofs shall comply with either the maximum assembly U factor or the minimum insulation R -value in Table 9. R -value is for the insulation alone and does not include building materials or air films. The roof insulation shall not be located on a suspended ceiling with removable ceiling panels.

Table 9 Roof assembly U -factor and Insulation R -value Requirements

SI No.	Climate Zone	24-Hour use buildings		Daytime use buildings	
		Hospitals, Hotels, Call Centers, etc		Other Building Types	
		Maximum U -factor of the overall assembly ($W/m^2 - ^\circ C$)	Minimum R -value of insulation alone ($m^2 - ^\circ C/W$)	Maximum U -factor of the overall assembly ($W/m^2 - ^\circ C$)	Minimum R -value of insulation alone ($m^2 - ^\circ C/W$)
(1)	(2)	(3)	(4)	(5)	(6)
i)	Composite	U-0.261	R-3.5	U-0.409	R-2.1
ii)	Hot and Dry	U-0.261	R-3.5	U-0.409	R-2.1
iii)	Warm and Humid	U-0.261	R-3.5	U-0.409	R-2.1
iv)	Moderate	U-0.409	R-2.1	U-0.409	R-2.1
v)	Cold	U-0.261	R-3.5	U-0.409	R-2.1

Cool roofs with slopes less than 20° shall have an initial solar reflectance of not less than 0.70 and an initial emittance not less than 0.75.

B-2 OPAQUE WALLS

Opaque walls shall comply with either the maximum assembly U -factor or the minimum insulation R -value in Table 10. R -value is for the insulation alone and does not include building materials or air films.

Table 10 Opaque Wall Assembly U -factor and Insulation R -value Requirements

SI No.	Climate Zone	Hospitals, Hotels, Call Centers (24-Hour)		Other Building Types (Daytime)	
		Maximum U-factor of the overall assembly (W/m ² - °C)	Minimum R-value of insulation alone (m ² - °C/W)	Maximum U-factor of the overall assembly (W/m ² - °C)	Minimum R-value of insulation alone (m ² - °C/W)
(1)	(2)	(3)	(4)	(5)	(6)
i)	Composite	U-0.440	R-2.10	U-0.440	R-2.10
ii)	Hot and Dry	U-0.440	R-2.10	U-0.440	R-2.10
iii)	Warm and Humid	U-0.440	R-2.10	U-0.440	R-2.10
iv)	Moderate	U-0.431	R-1.80	U-0.397	R-2.00
v)	Cold	U-0.369	R-2.20	U-0.352	R-2.35

B-3 VERTICAL FENESTRATION

Vertical fenestration shall comply with the maximum area weighted *U*-factor and maximum area weighted SHGC requirements of Table 11. Vertical fenestration area is limited to a maximum of 60 percent of the gross wall area for the prescriptive requirement.

Table 11 Vertical Fenestration *U*-factor and SHGC Requirements

SI No.	Climate	Maximum U-factor W/m ² - °C	Maximum SHGC	
			WWR ≤ 40%	40% < WWR ≤ 60%
(1)	(2)	(3)	(4)	(5)
i)	Composite	3.30	0.25	0.20
ii)	Hot and Dry	3.30	0.25	0.20
iii)	Warm and Humid	3.30	0.25	0.20
iv)	Moderate	6.90	0.40	0.30
v)	Cold	3.30	0.51	0.51

Alternative overhangs and/or side fins may be applied in determining the SHGC for the proposed design. An adjusted SHGC, accounting for overhangs and/or side fins is calculated by multiplying the SHGC of the unshaded fenestration product times a multiplication (*M*) factor. If this exception is applied, a separate *M* Factor shall be determined from Table 5 for each orientation and unique shading condition.

Vertical fenestration areas located more than 2.2 m above the level of the floor are exempt from the SHGC requirement in Table 11, if the following conditions are complied with:

- a) The total effective aperture for the elevation is less than 0.25, including all fenestration areas greater than 1.0 m above the floor level; and
- b) An interior light shelf is provided at the bottom of this fenestration area, with an interior projection factor (PF) not less than:
 - 1) 1.0 for *E-W, SE, SW, NE, and NW* orientations
 - 2) 0.5 for *S* orientation, and
 - 3) 0.35 for *N* orientation when latitude is $< 23^\circ$.

B-3.1 Minimum Visible Transmission (VLT) of Glazing for Vertical Fenestration.

To permit the use of available day lighting in place of electric lighting, glazing products used in offices, banks, libraries, classrooms with predominant daytime usage, shall have the minimum VLT, defined as function of WWR, where effective aperture is greater than 0.1, equal to or greater than the minimum VLT requirements of Table 12. Table 12 also indicates recommended VLT ranges for daylight applications in such spaces.

Table 12 Minimum Visual Light Transmission Light Transmission Requirements

SI No.	Window Wall Ratio	Minimum VLT
(1)	(2)	(3)
i)	0-0.3	0.27
ii)	0.31-0.4	0.20
iii)	0.41-0.5	0.16
iv)	0.51-0.6	0.13
v)	0.61-0.7	0.11

B-4 SKYLIGHT

Skylights shall comply with the maximum *U*-factor and a maximum SHGC requirement of Table 13. Skylight area is limited to a minimum of 5 percent of the gross roof area for the prescriptive requirement.

Table 13 Skylight U-Factor and SHGC requirements (U-factor in)

SI No.	Climate	Maximum U-factor (in W/m ² °C)		Maximum SHGC	
		With Curb	w/o Curb	0-2% SRR	2.1-5% SRR
(1)	(2)	(3)	(4)	(5)	(6)
i)	Composite	11.24	7.71	0.40	0.25
ii)	Hot and Dry	11.24	7.71	0.40	0.25
iii)	Warm and Humid	11.24	7.71	0.40	0.25
iv)	Moderate	11.24	7.71	0.61	0.4
v)	Cold	11.24	7.71	0.61	0.4

ANNEX C

[Clause 7.2(b)]

TRADE-OFF METHOD FOR ENVELOPE OPTIMIZATION

C-1 The building envelope complies with the code if the building envelope performance factor (EPF) of the proposed design is less than the standard design, where the standard design exactly complies with the criteria in Annex B. The envelope performance factor shall be calculated using the following equations:

$$EPF_{Total} = EPF_{Roof} + EPF_{Wall} + EPF_{Fenest}$$

where

$$EPF_{Roof} = c_{Roof} \sum_{s=1}^n U_s A_s$$

$$EPF_{Wall} = c_{Wall,Mass} \sum_{s=1}^n U_s A_s + c_{Wall,Other} \sum_{s=1}^n U_s A_s$$

$$EPF_{Fenest} = c_{1Fenest,North} \sum_{w=1}^n SHGC_w M_w A_w + c_{2Fenest,North} \sum_{w=1}^n U_w A_w +$$

$$c_{1Fenest,NonNorth} \sum_{w=1}^n SHGC_w M_w A_w + c_{2Fenest,NonNorth} \sum_{w=1}^n U_w A_w +$$

$$c_{1Fenest,Skylight} \sum_{s=1}^n SHGC_s A_s + c_{2Fenest,Skylight} \sum_{s=1}^n U_s A_s$$

where

EPF_{Wall} , EPF_{Fenest} & EPF_{Roof}	= Envelope performance factor for walls, fenestration and roofs respectively;
A_s , A_w	= The area of a specific envelope component referenced by the subscript 's' or for windows reference by the subscript 'w';
$SHGC_w$, $SHGC_s$	= The solar heat gain coefficient for windows and skylights;
M_w	= A multiplier for the $SHGC_w$ that depends on the projection factor of an overhang or side fin as given in Table 5;
U_s	= The U -factor for the envelope component referenced by the subscript 's';
c_{Roof} , $c_{wall, mass}$, $c_{wall, other}$, and $c_{fenest, north}$ $c_{fenest, non-north}$ $c_{fenest, skylight}$	= A coefficient for the roof, wall, window and skylight class of construction. Values of c are taken from Table 14 to Table 18 for each class of construction.

Table 14 Envelope Performance Factor Coefficients – Composite Climate

SI No.	Building Component	Daytime Occupancy		24-Hour Occupancy	
		U-factor (W/m ² .K)	SHGC	U-factor (W/m ² .K)	SHGC
(1)	(2)	(3)	(4)	(5)	(6)
i)	Mass Walls	6.01	-	13.85	-
ii)	Curtain Walls, Other	15.72	-	20.48	-
iii)	Roofs	11.93	-	24.67	-
iv)	North Windows	-1.75	40.65	-4.56	58.15
v)	Non-North Windows	- 1.25	54.51	0.68	86.57
vi)	Skylights	-96.35	311.71	-294.66	918.77

Table 15 Envelope Performance Factor Coefficients – Hot Dry Climate

SI No.	Building Component	Daytime Occupancy		24-Hour Occupancy	
		U-factor (W/m ² .K)	SHGC	U-factor (W/m ² .K)	SHGC
(1)	(2)	(3)	(4)	(5)	(6)
i)	Mass Walls	5.48	-	15.01	-
ii)	Curtain Walls, Other	6.38	-	22.06	-
iii)	Roofs	11.14	-	25.98	-
iv)	North Windows	-2.40	36.57	-1.49	56.09
v)	Non-North Windows	- 1.86	46.79	1.187	81.79
vi)	Skylights	-96.27	309.33	-295.81	923.01

Table 16 Envelope Performance Factor Coefficient – Warm Humid Climate

SI No.	Building Component	Daytime Occupancy		24-Hour Occupancy	
		U-factor (W/m ² .K)	SHGC	U-factor (W/m ² .K)	SHGC
(1)	(2)	(3)	(4)	(5)	(6)
i)	Mass Walls	6.42	-	9.60	-
ii)	Curtain Walls, Other	14.77	-	19.71	-
iii)	Roofs	9.86	-	14.11	-

iv)	North Windows	-1.58	34.95	-7.29	64.19
v)	Non-North Windows	- 1.00	43.09	-6.48	76.83
vi)	Skylights	-96.11	305.45	-295.45	893.55

Table 17 Envelope Performance Factor Coefficient – Temperate Climate

SI No.	Building Component	Daytime Occupancy		24-Hour Occupancy	
		U-factor	SHGC	U-factor	SHGC
		(W/m ² .K)		(W/m ² .K)	
(1)	(2)	(3)	(4)	(5)	(6)
i)	Mass Walls	2.017	-	3.11	-
ii)	Curtain Walls, Other	2.72	-	4.11	-
iii)	Roofs	5.46	-	5.86	-
iv)	North Windows	-3.10	29.66	-11.95	62.14
v)	Non-North Windows	- 2.98	34.86	-11.62	68.45
vi)	Skylights	-96.21	298.82	-294.12	876.70

Table 18 Envelope Performance Factor Coefficient – Cold Climate

SI No.	Building Component	Daytime Occupancy		24-Hour Occupancy	
		U-factor	SHGC	U-factor	SHGC
		(W/m ² .K)		(W/m ² .K)	
(1)	(2)	(3)	(4)	(5)	(6)
i)	Mass Walls	5.19	-	5.19	-
ii)	Curtain Walls, Other	6.76	-	6.76	-
iii)	Roofs	5.69	-	5.67	-
iv)	North Windows	1.55	9.13	1.55	9.13
v)	Non-North Windows	- 1.13	16.32	-1.13	16.32
vi)	Skylights	-93.44	283.18	-93.44	283.18

ANNEX D

[Clause 8.2(d)]

WHOLE BUILDING ANALYSIS METHOD FOR ENVELOPE OPTIMIZATION

D-1 A building complies with the whole building performance requirement when the estimated annual energy use of the proposed design is less than the standard design, even though it may not comply with the specific requirements of the prescriptive requirements given in Annex B. Annual energy use for the purposes of the whole building performance method shall be calculated in kilowatt-hours (kWh) of electricity use per year.

D-2 SIMULATION GENERAL REQUIREMENTS

A simulation program may be used for the analysis of energy consumption in buildings to model the following:

- a) Energy flows on an hourly basis for all 8 760 h in the year;
- b) Hourly variations in occupancy, lighting power, miscellaneous equipment power, thermostat set points and HVAC system operation, defined separately for each day of the week and holidays;
- c) Thermal mass effects;
- d) Ten or more thermal zones;
- e) Part-load and temperature dependent performance of heating and cooling equipment;
- f) Air-side and water-side economizers with integrated control; and
- g) All the standard design characteristics specified in this chapter.

The simulation program shall use hourly values of climatic data, such as temperature and humidity from representative climatic data, for the city in which the proposed building is to be located. For cities or urban regions with several climatic data entries, and for locations where weather data are not available, the designer shall select available weather data that best represent the climate at the construction site.

The proposed design and standard design shall be calculated using the following:

- a) Same simulation program,
- b) Same weather data, and
- c) Same building operation assumptions (thermostat set points, schedules, internal gains, occupant loads, etc).

D-3 CALCULATING THE ENERGY CONSUMPTION OF THE PROPOSED DESIGN AND THE STANDARD DESIGN.

The simulation model for calculating the proposed design and the standard design shall be developed in accordance with the requirements in Table 19. The HVAC system type and related performance parameters for the standard design shall be determined from Table 20 and the following rules:

- a) All HVAC and service water heating equipment in the standard design shall be modelled at the minimum efficiency levels, both part load and full load.
- b) Where efficiency ratings, such as energy efficiency ratio (EER) and COP, include fan energy, the descriptor shall be broken down into its components so that supply fan energy can be modelled separately.
- c) Minimum outdoor air ventilation rates shall be the same for both the standard design and the proposed design.
- d) The equipment capacities for the standard design shall be sized proportionally to the capacities in the proposed design based on sizing runs; that is, the ratio between the capacities used in the annual simulations and the capacities determined by the sizing runs shall be the same for both the proposed design and standard design. Unmet load hours for the proposed design shall not differ from unmet load hours for the standard design by more than 50 hours.

Components and parameters not listed in Table 20 or otherwise specifically addressed in this Part of the Code shall be identical to those in the proposed design. Where there are specific requirements in this Part of the Code the component efficiency in the standard design shall be adjusted to the lowest efficiency level allowed by the requirement for that component type.

Table 19 Modelling Requirements for Calculating Proposed and Standard Design

Case	Proposed Building	Standard Design
1. Design Model	<p>a) The simulation model of the proposed design shall be consistent with the design documents, including proper accounting of fenestration and opaque envelope types and area; interior lighting power and controls; HVAC system types, sizes, and controls; and service water heating systems and controls.</p> <p>b) When the whole building performance method is applied to buildings in which energy-related features have not yet been designed (e.g. a lighting system), those yet-to-be-designed features shall be described in the proposed design so that they minimally comply with applicable mandatory and prescriptive requirements.</p>	The standard design shall be developed by modifying the proposed design as described in this table. Except as specifically instructed in this table, all building systems and equipment shall be modelled identically in the standard design and proposed design.
2. Space Use Classification	The building type or space type classifications shall be chosen in accordance with this code. More than one building type category may be used in a building if it is a mixed-use facility.	Same as proposed design.
3. Schedules	The schedules shall be typical of the proposed building type as determined by the designer.	Same as proposed design
4. Building Envelope	<p>All components of the building envelope in the proposed design shall be modelled as shown on architectural drawings or as installed for existing building envelopes.</p> <p><i>Exceptions:</i> The following building elements are permitted to differ from</p>	The standard design shall have identical conditioned floor area and identical exterior dimensions and orientations as the proposed design, except as noted in (a),(b), (c), and (d) below:

	<p>architectural drawings:</p> <p>a) Any envelope assembly that covers less than 5% of the total area of that assembly type (e.g., exterior walls) need not be separately described. If not separately described, the area of an envelope assembly shall be added to the area of the adjacent assembly of that same type.</p> <p>b) Exterior surfaces whose azimuth orientation and tilt differ by no more than 45° and are otherwise the same may be described as either a single surface or by using multipliers.</p> <p>c) For exterior roofs other than roofs with ventilated attics, the reflectance and emittance of the roof surface shall be modelled.</p> <p>d) Manually operated fenestration shading devices such as blinds or shades shall not be modelled. Permanent shading devices such as fins, overhangs, and light shelves shall be modelled.</p>	<p>a) <i>Orientation</i> – The baseline building performance shall be generated by simulating the building with its actual orientation and again after rotating the entire building 90°, 180°, 270°, then averaging the results. The building shall be modelled so that it does not shade itself.</p> <p>b) Opaque assemblies such as roof, floors, doors, and walls shall be modelled as having the same heat capacity as the proposed design but with the minimum <i>U</i>-factor required in B-1 and B-2.</p> <p>c) <i>Fenestration</i> — Fenestration areas shall equal that in the proposed design or 40% of gross above grade wall area, whichever is smaller, and shall be distributed uniformly in horizontal bands across the four orientations. No shading projections are to be modelled; fenestration shall be assumed to be flush with the exterior wall or roof. Manually operated fenestration shading devices such as blinds or shades shall not be modelled. Fenestration <i>U</i>-factor shall be the minimum required for the climate, and the solar heat gain coefficient shall be the maximum allowed for the climate and orientation.</p> <p>d) <i>Roof albedo</i> – All roof surfaces shall be modelled with a reflectivity of 0.30</p>
5. Lighting	<p>Lighting power in the proposed design shall be determined as follows:</p> <p>a) Where a complete lighting system exists, the actual lighting power shall be used in the model.</p> <p>b) Where a lighting system has been designed, lighting power shall be determined.</p> <p>c) Where no lighting exists or is specified, lighting power shall be determined for the appropriate building type.</p> <p>d) Lighting system power shall include all lighting system components shown or provided for on plans (including lamps, ballasts, task fixtures, and furniture-mounted fixtures).</p>	<p>Lighting power in the standard design shall be determined using the same categorization procedure (building area or space function) and categories as the proposed design with lighting power shall be set equal to the maximum allowed for the corresponding method and category in power for fixtures not included in the lighting power density calculation shall be modelled identically in the proposed design and standard design. Lighting controls shall be the minimum required.</p>
6. HVAC System	<p>The HVAC system type and all related performance parameters, such as equipment capacities and efficiencies, in the proposed design shall be determined as follows:</p> <p>a) Where a complete HVAC system exists, the model shall reflect the actual system type using actual component capacities and efficiencies.</p> <p>b) Where an HVAC system has been designed, the HVAC model shall be consistent with design documents. Mechanical equipment efficiencies shall be adjusted from actual design conditions to the standard rating</p>	<p>The HVAC system type and related performance parameters for the standard design shall be determined from Table 20. Equipment performance shall meet the requirements of this code.</p>

	<p>conditions if required by the simulation model.</p> <p>c) Where no heating system exists or no heating system has been specified, the heating system shall be modelled as electric resistance. The system characteristics shall be identical to the system modelled in the standard design.</p> <p>d) Where no cooling system exists or no cooling system has been specified, the cooling system shall be modelled as an air-cooled single zone system, one unit per thermal block. The system characteristics shall be identical to the system modelled in the standard design.</p>	
7. Service hot water	<p>The service hot water system type and all related performance parameters, such as equipment capacities and efficiencies, in the proposed design shall be determined as follows:</p> <p>a) Where a complete service hot water system exists, the model shall reflect the actual system type using actual component capacities and efficiencies.</p> <p>b) Where a service hot water system has been designed, the service hot water model shall be consistent with design documents.</p> <p>c) Where no service hot water system exists or is specified, no service hot water heating shall be modelled.</p>	<p>The water heating system shall be of the same type of the proposed design.</p> <p>For residential facilities, hotels and hospitals the standard design shall have a solar system capable of meeting 20% of the design load.</p> <p>Systems shall meet the prescribed efficiency requirements of equipments, pipe insulation and incorporate heat traps.</p>
8. Miscellaneous load	<p>Receptacle, motor, and process loads shall be modelled and estimated based on the building type or space type category.</p> <p>These loads shall be included in simulations of the building and shall be included when calculating the standard design and proposed design. All end-use load components within and associated with the building shall be modelled, unless specifically excluded, but not limited to, exhaust fans, parking garage ventilation fans, exterior building lighting, swimming pool heaters and pumps, elevators and escalators, refrigeration equipment, and cooking equipment.</p>	<p>Receptacle, motor and process loads shall be modelled the same as the proposed design. The water heating system shall be of the same type of the proposed design.</p>
9. Modelling limitations to the simulation program	<p>If the simulation program cannot model a component or system included in the proposed design, one of the following methods shall be used with the approval of the authority having jurisdiction:</p> <p>a) Ignore the component if the energy impact on the trade-offs being considered is not significant.</p> <p>b) Model the component substituting a thermodynamically similar component model.</p> <p>c) Model the HVAC system components or systems using the standard design's HVAC system in accordance with Section 6 of this table.</p> <p>Whichever method is selected, the</p>	<p>Same as proposed case</p>

	component shall be modelled identically for both the proposed design and standard design models.	
--	--	--

Table 20 HVAC System Map

Residential		Non Residential		
	More than 3 Stories	Less than 3 floors or less than 7 500 m ²	4 or 5 floors or less than 7 500 m ² or 5 floors or less and 7 500 – 15 000 m ²	More than 5 floors or more than 15 000 m ²
Code	PTAC	PSZ	RHFS	RHFS
System Type	Packaged terminal air-conditioner	Packaged rooftop air-conditioner	Central cooling plant with constant volume AHU for each zone	Central cooling plant with constant volume AHU for each zone
Fan control	Constant volume	Constant volume	Constant volume air handler for each zone	Variable volume air handler
Cooling type	Direct expansion	Direct expansion	Chilled Water*	Chilled Water*
Heating type	Electric resistance	Electric resistance	Electric resistance	Electric resistance

NOTE – If the proposed building has an air cooled chiller/system then the budget building shall have Air cooled chiller otherwise the budget case shall have water cooled centrifugal chillers.

LIST OF STANDARDS

The following list records those standards which are acceptable as 'good practice' and 'accepted standards' in the fulfilment of the requirements of the Code. The standards listed may be used by the Authority as a guide in conformance with the requirements of the referred clauses in the Code.

(1)	IS 15792:2002	Guidelines for artificial recharge to ground water
	IS 15797:2008	Guidelines for roof top rain water harvesting
(2)	IS 3792:1978	Guide for heat insulation of non-industrial buildings (<i>first revision</i>)
(3)	IS 456:2000	Code of practice for plain and reinforced concrete (<i>fourth revision</i>)
(4)	IS 4926:2003	Code of practice for ready-mixed concrete (<i>third revision</i>)
(5)	IS 455:1989	Specification for Portland Slag cement (<i>fourth revision</i>)
	IS 456:2000	Code of practice for plain and reinforced concrete (<i>fourth revision</i>)
	IS 457:1957	Code of practice for general construction of plain and reinforced concrete for dams and other massive structures
	IS 458:2003	Specification for precast concrete pipes (with and without reinforcement) (<i>fourth revision</i>)
	IS 459:1992	Specification for unreinforced corrugated and semi-corrugated asbestos cement sheets (<i>third revision</i>)
	IS 1332:1986	Specification for precast reinforced concrete steel lighting poles (<i>first revision</i>)
	IS 1343:2012	Code of practice for prestressed concrete (<i>second revision</i>)
	IS 1489 (Pt 1):1991	Specification for Portland-pozzolana cement: Part 1 Fly ash based (<i>third revision</i>)
	IS 1489 (Pt 2):1991	Specification for Portland-pozzolana cement: Part 2 Calcined clay based (<i>third revision</i>)
	IS 1592:2003	Specification for asbestos cement pressure pipes and joints (<i>fourth revision</i>)
	IS 1626(Pt 1):1994	Specification for asbestos cement building pipes and pipe fittings, gutters and gutter fittings and roofing fittings: Part 1 Pipe and pipe fittings (<i>second revision</i>)
	IS 1626(Pt 2):1994	Specification for asbestos cement building pipes and pipe fittings, gutters and gutter fittings and roofing fittings: Part 2 Gutters and gutter fittings (<i>second revision</i>)

IS 1626(Pt 3):1994	Specification for asbestos cement building pipes and pipe fittings, gutters and gutter fittings and roofing fittings: Part 3 Roofing accessories (second revision)
IS 1727:1967	Methods of test for pozzolanic materials (first revision)
IS 2096:1992	Specification for asbestos cement flat sheets
IS 2098:1997	Specification for asbestos cement building boards
IS 2117:1991	Guide for manufacture of hand-made common burnt clay building bricks (second revision)
IS 2185(Pt 1):2005	Specification for concrete masonry units : Part 1 Hollow and solid concrete blocks (third revision)
IS 2185(Pt 2):1983	Specification for concrete masonry units : Part 2 Hollow and solid light-weight concrete blocks (first revision)
IS 2185(Pt 3):1984	Specification for concrete masonry units : Part 3 Autoclaved cellular (aerated, concrete blocks (first revision)
IS 2185(Pt 4):2008	Specification for concrete masonry units : Part 4 Preformed foam cellular concrete blocks
IS 2541:1991	Code of practice for preparation and use of lime concrete (second revision)
IS 3115:1992	Specification for lime based blocks (second revision)
IS 3370(Part 1):2009	Code of practice for concrete structures for storage of liquids: Part 1 General requirements (first revision)
IS 3370(Part 2):2009	Code of practice for concrete structures for storage of liquids: Part 2 Reinforced concrete structures (first revision)
IS 3466:1988	Specification for masonry cement (second revision)
IS 3812(Part 1):2003	Specification for pulverized fuel ash: Part 1 For use as Pozzolana in cement, cement mortar and concrete (second revision)
IS 3812(Part 2):2003	Specification for pulverized fuel ash: Part 2 For use as admixture in cement mortar and concrete (second revision)
IS 4098:1983	Specification for lime-pozzolana mixture (first revision)
IS 4139:1989	Specification for calcium silicate bricks (second revision)
IS 4926: 2003	Code of practice for ready-mixed concrete (second revision)
IS 5817:1992	Code of practice for preparation and use of lime pozzolana mixture concrete in buildings and roads (first revision)
IS 5820:1970	Specification for precast concrete cable cover

IS 6041:1985	Code of practice for construction of autoclaved cellular concrete block masonry (first revision)
IS 6042:1969	Code of practice for construction of lightweight concrete block masonry
IS 6066:1994	Recommendations for pressure grouting of rock foundations in river valley projects (second revision)
IS 6072:1971	Specification for autoclaved reinforced cellular concrete wall slabs
IS 6073:2006	Specification for autoclaved reinforced cellular concrete floor and roof slabs (first revision)
IS 6908 :1991	Specification for asbestos cement pipes and fittings for sewerage and drainage
IS 8229:1986	Specification for oil-well cement (first revision)
IS 9142:1979	Specification for artificial light-weight aggregates for concrete masonry units
IS 9375:1979	Specification for precast reinforced concrete plant guards
IS 9627:1980	Specification for asbestos cement pressure pipes (light duty)
IS 9872:1981	Specification for precast concrete septic tanks
IS 9893:1981	Specification for precast concrete lintels and sills
IS 10049:1981	Code of practice for manufacture of lime based blocks
IS 10262:2009	Guidelines for concrete mix proportioning (first revision)
IS 10359:1982	Code of practice for manufacture and use of lime-pozzolana concrete blocks for paving
IS 10360:1982	Specification for lime-pozzolana concrete blocks for paving
IS 10772:1983	Specification for quick setting lime-pozzolana mixture
IS 11293(Part 1):1985	Guidelines for design of grout curtains: Part 1 Earth and rockfill dams
IS 11293(Part 2):1993	Guidelines for design of grout curtains: Part 2 Masonry and concrete dams
IS 11650:1991	Guide for manufacture of common burnt clay building bricks by semi-mechanized process (first revision)
IS 12089:1987	Specification for granulated slag for manufacture of Portland slag cement
IS 12440:1988	Specification for precast concrete stone masonry blocks
IS 12592: 2002	Specification for precast concrete manhole cover and frame
IS 12894:2002	Specification for pulverized fuel ash lime bricks

		(first revision)
	IS 13000:1990	Specification for silica-asbestos cement flat sheets
	IS 13008:1990	Specification for shallow corrugated asbestos cement sheets
	IS 13757:1993	Specification for burnt clay fly ash building bricks
	IS 14862:2000	Specification for fibre cement flat sheets
	IS 14871:2000	Specification for products in fibre reinforced cement - long corrugated or asymmetrical section sheet and fittings for roofing and cladding
	IS 15288:2003	Specification for silica fume
	IS 15648:2006	Specification for pulverized fuel ash for lime pozzolana mixture application
	IS 15916:2010	Code of practice for building design and erection using prefabricated concrete (<i>under print</i>)
	IS 15917:2010	Code of practice for building design and erection using mixed/composite construction (<i>under print</i>)
(6)	IS 2686:1977	Specification for cinder as fine aggregates for use in lime concrete (First revision)
	IS 3068:1986	Specification for broken brick (burnt clay) coarse aggregates for use in lime concrete (second revision)
	IS 3182:1986	Specification for broken brick (burnt clay) fine aggregates for use in lime mortar (second revision)
	IS 9142:1979	Specification for artificial light-weight aggregates for concrete masonry units
(7)	IS 9142:1979	Specification for artificial light-weight aggregates for concrete masonry units
(8)	IS 2185	Specification for concrete masonry units
	(Part 1):2005	Part 1 Hollow and solid concrete blocks (<i>third revision</i>)
	(Part 2):1983	Part 2 Hollow and solid lightweight concrete blocks (<i>first revision</i>)
	(Part 3):1984	Part 3 Autoclaved cellular (aerated) concrete blocks (<i>first revision</i>)
	(Part 4):2008	Part 4 Preformed foam cellular concrete blocks
	IS 12440:1988	Specification for precast concrete stone masonry blocks
(9)	IS 2572:2005	Code of practice for construction of hollow concrete block masonry (<i>first revision</i>)
	6041:1985	Code of practice for construction of autoclaved cellular concrete block masonry (<i>first revision</i>)
	6042:1969	Code of practice for construction of lightweight concrete block masonry
(10)	IS 1725:1982	Specification for soil-based blocks used in general

		building construction
(11)	IS 401:2001	Code of practice for preservation of timber (<i>fourth revision</i>)
	IS 1141:1993	Code of practice for seasoning of timber (<i>second revision</i>)
(12)	IS 303:1989	Specification for plywood for general purposes (Third revision)
	IS 710:2010	Specification for marine plywood (second revision)
	IS 1328:1996	Specification for veneered decorative plywood (Third revision)
	IS 1658:1977	Specification for fibre hardboards (<i>second revision</i>)
	IS 1659:1990	Specification for block boards (<i>third revision</i>)
	IS 3087:1985	Specification for wood particle boards (medium density) for general purposes (<i>first revision</i>)
	IS 3097:1980	Specification for veneered particle boards (<i>first revision</i>)
	IS 3129:1985	Specification for low density particle board (<i>first revision</i>)
	IS 3308:1981	Specification for wood wool building slabs (<i>first revision</i>)
	IS 4990:1993	Specification for plywood for concrete shuttering work (<i>second revision</i>)
	IS 5509:2000	Specification for fire retardant plywood (<i>second revision</i>)
	IS 12406:2003	Specification for medium density fibreboards for general purposes (<i>first revision</i>)
	IS 12823:1990	Specification for prelaminated particle boards
	IS 13958:1994	Specification for bamboo mat board for general purposes
	IS 14587:1998	Specification for prelaminated medium density fibre board
	IS 14588:1999	Specification for bamboo mat veneer composite for general purposes
	IS 14616:1999	Specification for laminated veneer lumber
	IS 14842:2000	Specification for coir veneer board for general purposes
	IS 15380:2003	Specification for moulded raised high density fibre (HDF) panel doors
	IS 15476:2004	Specification for bamboo and corrugated sheets
	IS 15491:2004	Specification for medium density coirboards for

		general purposes
	IS 15877:2010	Specification for coir faced block boards
	IS 15878:2010	Specification for coir hardboard for general purposes
(13)	IS 2250:1981	Code of practice for preparation and use of masonry mortars (First revision)
	IS 4443:1980	Code of practice for use of resin type chemical resistant mortars (First revision)
	IS 4832	Specification for chemical resistant mortars:
	(Part I):1969	Part I Silicate type
	(Part 2):1969	Part II Resin type
	(Part 3):1969	Part III Sulphur type
(14)	IS 13077:1991	Guide for preparation and use of mud mortar in masonry
(15)	IS 653:1992	Specification for linoleum sheets and tiles (<i>third revision</i>)
	IS 1198:1982	Code of practice for laying, fixing and maintenance of linoleum floor (<i>first revision</i>)
(16)	IS 1237:1980	Specification for cement concrete flooring tiles (<i>first revision</i>)
	IS 1443:1972	Code of practice for laying and finishing of cement concrete flooring tiles (<i>first revision</i>)
	IS 2114:1984	Code of practice for laying in-situ terrazzo floor finish (<i>first revision</i>)
(17)	IS 15622:2006	Specification for pressed ceramic tiles
(18)	IS 1661:1972	Code of practice for application of cement and cement-lime plaster finish (<i>first revision</i>)
(19)	IS 2547	Specification for gypsum building plaster
	(Part 1):1976	Part 1 Excluding premixed lightweight plaster (<i>first revision</i>)
	(Part 2):1976	Part 2 Premixed lightweight plaster (<i>first revision</i>)
	IS 12679:1989	Specification for by-product gypsum for use in plaster, blocks and boards
(20)	IS 14862:2000	Specification for fibre cement flat sheets
	IS 14871:2000	Specification for products in fibre reinforced cement long corrugated or asymmetrical section sheets and fittings for roofing and cladding
(21)	IS 2095	Specification for gypsum plaster boards

	(Part 1):1996	Part 1 Plain gypsum plaster boards
	(Part 2):2001	Part 2 Coated/laminated gypsum plaster boards
	(Part 3):1996	Part 3 Reinforced gypsum plaster boards (<i>second revision</i>)
	IS 8272:1984	Specification for gypsum plaster for use in the manufacture of fibrous plasterboards (<i>first revision</i>)
(22)	IS 4021:1995	Specification for timber door, window and ventilator frames
(23)	IS 6523:1983	Specification for precast reinforced concrete door and window frames (<i>first revision</i>)
(24)	IS 8183:1993	Specification for bonded mineral wool (<i>first revision</i>)
(25)	IS 3677:1985	Specification for unbonded rock and slag wool for thermal insulation (<i>second revision</i>)
(26)	IS 2115:1980	Code of practice for flat roof finish: Mud phuska (<i>second revision</i>)
(27)	IS 4082:1996	Recommendations on stacking and storage of construction materials and components at site (<i>second revision</i>)
	IS 7969:1975	Safety code for handling and storage of building materials
(28)	IS 10500:1991	Drinking water (<i>first revision</i>)
	IS 11624:1986	Guidelines for the quality of irrigation water
	IS 8188:1999	Treatment of Water for Cooling Towers – Code of Practice
	IS 201:1992	Quality tolerances for water for textile industry (<i>second revision</i>)
	IS 2724:1964	Quality tolerances for water for pulp and paper
	IS 2725:1964	Quality tolerances for water for rayon-manufacturing industry
	IS 3328:1993	Quality tolerances for water for swimming pools (<i>first revision</i>)
	IS 4221:1967	Quality tolerances for water for tanning industry
	IS 4251:1967	Quality tolerances for water for processed food industry
	IS 4700:1968	Quality tolerances for water for fermentation
	IS 8914:1988	Quality tolerances for water for vitreous enamel industry (<i>first revision</i>)
	IS 10392:1982	Specification for feed water and boiler water for low

		and medium pressure boilers
	IS 10496:1983	Specification for feed water, boiler water and condensate for high pressure boilers
	IS 13891:1994	Quality tolerances for fresh water for fish culture
	IS 3957:1966	Quality tolerances for water for ice manufacture
(29)	IS 15883(Part 1):2009	Guidelines for Construction Project Management: Part 1 General
(30)	IS 456:2000	Code of practice for plain and reinforced concrete (<i>fourth revision</i>)
	IS 1343:2012	Code of practice for prestressed concrete (<i>second revision</i>)
(31)	IS 4130:1991	Safety code for demolition of buildings

ced46\ced46-tech\ced46-T24\wc\07-12-2012