



A KYOCERA GROUP COMPANY

Thermal Management of Surface Mounted Tantalum Capacitors

Ian Salisbury

AVX-Kyocera Group Company Limited, Paignton, England, TQ4 7ER

ABSTRACT

This paper covers thermal management of surface mounted tantalum capacitors, and explores the thermal characteristics and how these are modified by the thermal interconnection substrate. The paper explores the different methods of mounting to reduce the thermal resistance to the PCB, also the affect of the design of connection pads on the PCB to reduce the thermal stress on the capacitor.

Introduction

Surface mount technology has evolved over the past decade. The main attention has been focused on the affect on the mounted device of the mechanical stress induced by environmental changes such as temperature, humidity and mechanical flexing of the printed circuit board, and how these effect the electrical and mechanical function. In applications such as d.c. converters and power supplies where the capacitor is stressed with high ripple currents the thermal considerations now become important. In order to review the thermal management of the capacitor we have to understand the construction of the present surface mount tantalum capacitor and the options of mounting the capacitor to the PCB.

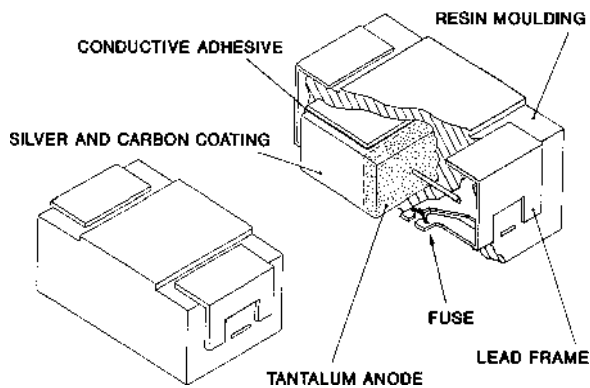

Figure 1. Mechanical Construction of a Tantalum Capacitor

The tantalum anode is made up of fine tantalum powder, which is pressed into a block, and then fired at high temperature generally between 1500 and 2000c to sinter the particles together. The sintered porous block contains about 50% by volume of tantalum, the rest being air. At the time of pressing the anode, a tantalum wire is inserted into the tantalum block and during the high temperature sinter is fused to the tantalum powder, this wire forms the anode positive connection to the capacitor.

The next stage is to form the dielectric over the tantalum metal surface. This is formed electrochemically by placing the anode in an electrolyte and passing an electrical current through the anode and electrolyte, very similar to a standard plating process. The tantalum pentoxide dielectric is formed by oxygen transfer from the water to the tantalum metal, forming a very stable dielectric tantalum pentoxide. To complete the capacitor the cathode electrode which is the negative connection, has to be added to the block. This is achieved by filling remaining space within the block with a conductor, the most common material used is

manganese dioxide. The tantalum block is then coated with carbon and silver at its lower end, away from the anode wire, to make a mechanically strong connection to the anode block.

The tantalum anode is then assembled to a metal lead frame, the anode wire is welded to the lead frame, and the cathode end of the block is connected by a conductive adhesive to the other end of the lead frame. The whole assembly is resin molded to provide mechanical and environmental protection.

Discussion

Generally capacitors are not considered as a heat generating device, and in most applications the internal heating is small. However, in cases where large ripple currents occur or where the ambient temperature is close to the maximum category temperature, then the thermal management is important to ensure that the tantalum capacitor anode does not overheat, and result in adverse reliability.

Specification of the thermal design limits by the component manufacture is not an easy process, as the capacitor manufacture can only give the worst case conditions for the capacitor in free air at maximum category temperature. This paper covers the elements which effect the thermal dissipation of the capacitor when mounted onto the printed circuit board.

Heating within a capacitor can occur from two conditions. Under normal operations, heating is a combination of the d.c. leakage current and the a.c. component of the signal. In general the d.c. leakage is very small and therefore the heating effect from this small current is not considered significant in this paper. But the ripple currents will be covered in detail as these can be a significant cause of heating.

The other condition is a fault condition. If a circuit is likely to malfunction and allow a reverse voltage on the capacitor in excess of the allowed reverse voltage rating or allow a large positive voltage pulse in excess of the rated working voltage, then the capacitor is likely to fail and become low resistance. Under these fault conditions the capacitor can pass high current, this of course is only possible if the power supply has the capability of supplying large currents. With these large currents flowing through the internal resistance of the failed capacitor, heating will occur and can cause burn damage to the equipment. If the circuit has the capability of

causing the capacitor to fail, the use of a fused capacitor will eliminate any likelihood of causing burn damage to the equipment.

**BINARY FUSE TYPES
GRAPH BLOW TIMES AGAINST AMPS**

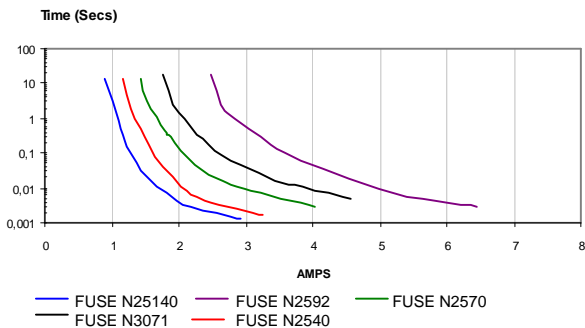

Figure 2. Fused Capacitor

The fusing conditions are set to open-circuit the capacitor under fault conditions thus preventing any damage to the circuit or equipment. These conditions can be adjusted to suit the application.

The main cause of heating is from the a.c. ripple currents. As a world leader in the manufacture and supply of tantalum capacitors, we are involved in many applications where the correct thermal design of the printed circuit board and the correct method of surface mounting is a major consideration to obtain the least thermal stress on the capacitor. Our recommended ripple ratings are published in our data sheets and technical notes, and these values are set by defining the maximum temperature rise under worst case conditions.

In order to thermally design a surface mounted capacitor into an electronic system we have to define the factors which effect their thermal management. These are:

1. Voltage and Current ratings
2. Equivalent series resistance
3. Physical size of capacitor
4. Ambient operating temperature
5. Method of assembly by the user
6. Encapsulation used on the PCB
7. Thermal design of equipment

From this list, the component manufacturer only has control of the first 3 factors, Voltage Rating, Equivalent Resistance and Physical Size, the other factors are in the hands of the equipment manufacturer.

If we consider each of the factors in turn, we can build up a thermal model which will help the system designer to design his assembly, with the least thermal stress.

Voltage and Current Ratings

Although Voltage Ratings of the capacitor are not directly related to thermal requirements they do limit

the stress on the dielectric and the correct choice of voltage working has to be made. The design limits for voltage operation are defined by the dielectric strength of the capacitor, which is controlled during manufacture. The general rules are:

1. The d.c. working voltage of the capacitor must not be exceeded by the positive peak of the applied a.c. voltage and d.c. bias voltage.
2. The sum of the applied d.c. bias voltage and negative peak of the a.c. voltage must not allow a voltage reversal in excess of that defined by:
 - (a) 10% of the rated reverse d.c. working voltage to a maximum of 1.0v at a temperature of 20c.
 - (b) 3% of the rated working voltage to a maximum of 0.5v at a temperature of 85c.
 - (c) 1% of the category d.c. working voltage to a maximum of 0.1v at a temperature of 125c.

The maximum a.c. ripple voltage (E max) for the application can be calculated by the formula:

$$E_{max} = Z\sqrt{(P_{max}/R)}$$

P = Max permissible power watts
 R = Equivalent series resistance, ohms
 Z = Impedance ohms at application frequency

Ripple Current

In an a.c. application, heat is generated within the capacitor body by the a.c. component of the signal. Using the formula below it is possible to calculate the maximum a.c. ripple current.

$$I_{max} = \sqrt{(P_{max}/R)}$$

I = rms ripple current in amps
 R = Equivalent series resistance, ohms
 P = Power dissipated in watts

The ability to calculate the maximum ripple ratings depends on the allowed power and the equivalent resistance.

Equivalent Series Resistance

The information on ESR in the data sheets is based on the maximum ESR value agreed in the international specifications for each product range. In practice, however, the capability of the manufacture is much better than these values. Also significant developments have been made by AVX, and a new range of low ESR capacitors has been designed, and are now available on the market as TEJ range.

The graph below gives the typical relationship between ESR and frequency.

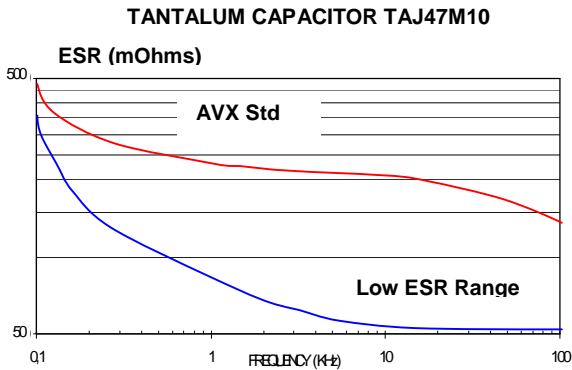

Figure 3. ESR vs Frequency

The International agreed ESR for this capacitor is 1.5 ohms, so it can be seen that significant improvements have been made in reducing the ESR. As discussed earlier, the heat generated by the a.c. signal within the capacitor is I^2R , and by defining the typical ESR of the standard product a close approximation to the true power can be calculated. If this power is too large then selection from the new range of low ESR devices can be made to reduce the power.

Physical Size

As electrical energy is dissipated within the body of the capacitor its temperature will rise, and we express this as the thermal impedance in deg C per watt. In free air the capacitor body will only be in contact with air to transfer its heat away, therefore as the surface area decreases (with case size) the power it is able to dissipate, will reduce for the same temperature rise.

The present physical size range of tantalum capacitors available to the industry ranges from R case size, a very small board area chip 2mm by 1.2mm known as 0805 (this expression is derived from the inch unit the size being 0.08 by 0.05 inches), to the larger E size 7.3mm by 4.1mm. In theory the different case sizes will have different thermal impedances.

The thermal impedance of each case size was measured by suspending the capacitor in free air using fine wires 0.005 inch dia. Wire of poor thermal conductivity was used to reduce the heat loss from the capacitor to a minimum. These fine wires were used to supply electrical energy to the capacitor.

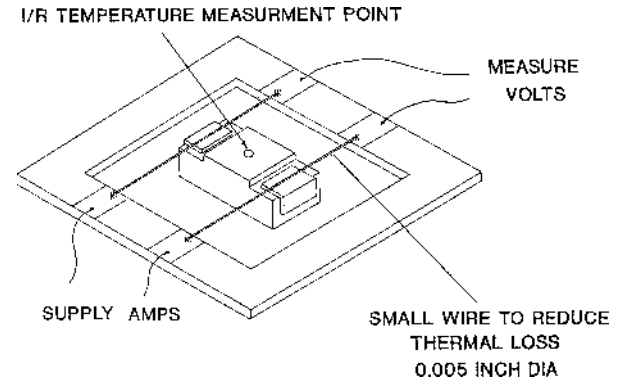

Figure 4. Test Method to define Thermal Impedance

The capacitor was electrically broken down by applying reverse voltage until the capacitor failed to a low impedance, then by increasing the current and measuring the volt drop across the capacitor, power in the package can be calculated.

The temperature of the outside surface was then measured by using an infrared probe. The advantage of the infrared probe is that no heat loss occurs, as there is no physical contact to the capacitor body, as would be the case if a thermocouple was used.

**THERMAL IMPEDANCE GRAPH
A,B,C & D CASE SIZE IN FREE AIR**

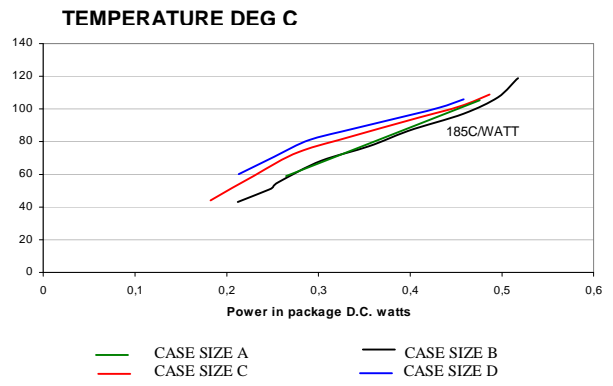

Figure 5. Thermal Impedance Graph Case Size A,B,C & D, In Free Air

In the study of the thermal impedance of the various case sizes, all units showed the same thermal impedance. We know from the theory that this is not correct. The reason for this result is that the heat loss along the fine wires, although low, was high in comparison to the small capacitor body, and the results indicate that we are measuring the thermal impedance of the supporting fine wires. This illustrates how sensitive heat loss from the small capacitor body to the surrounding air environment can be. In the rest of the paper we consider this effect.

Methods Of Surface Mounting

Surface mounted capacitors are assembled on to the various types of substrates using different materials and methods for the electrical connection and mechanical holding of the capacitor to the printed

circuit board. Three most common methods of assembly to the printed circuit board are Solder, Conductive resin and Wire bonding.

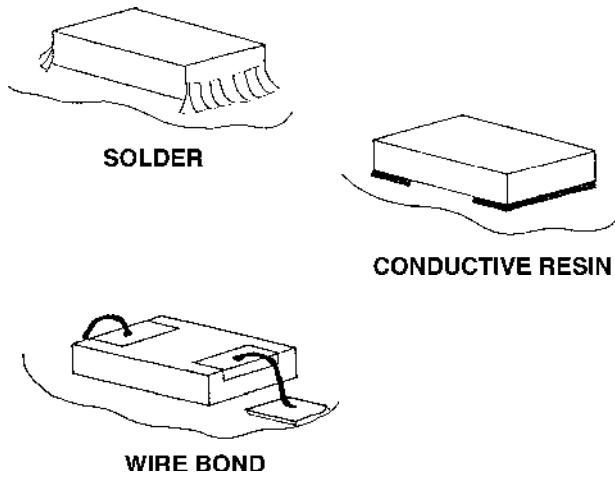

Figure 6. Drawing of the three methods of connection to PCB

These three methods will modify the thermal impedance from that of free air. The wire bonding will be closer to free air, and the solder assembly will have the lowest thermal impedance, as solder has a better thermal conductivity than conductive resin.

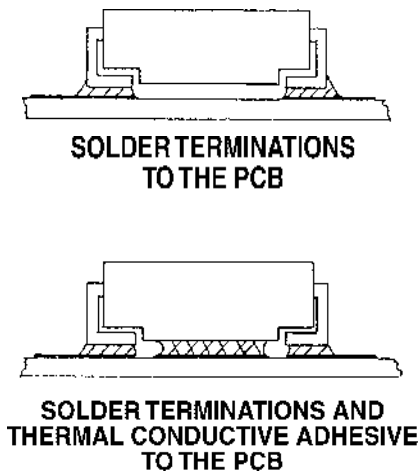

Figure 7. Drawing of Mechanical Attachment

If the capacitor is only in contact with the printed circuit board via the electrical connection pads, and an air space is allowed between the capacitor body and the printed circuit board, this will have a worse thermal impedance than if the capacitor body is thermally coupled to the printed circuit board. The area of copper on the board and the thermal conductivity of the substrate will also affect the thermal impedance.

THERMAL IMPEDANCE GRAPH C CASE SIZE CAPACITOR BODY

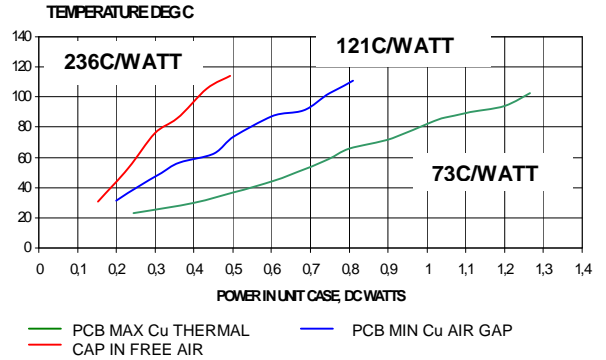

Figure 8. Thermal Impedance Graph - C Case Size Capacitor Body

The above graph illustrates the significant effect that the method of mounting and the design of the printed circuit board has on the thermal impedance.

Thermal Impedance Model

Thermal impedance of the capacitor can be modeled by combining two elements, Thermal resistance and Thermal capacitance.

THERMAL IMPEDANCE MODEL

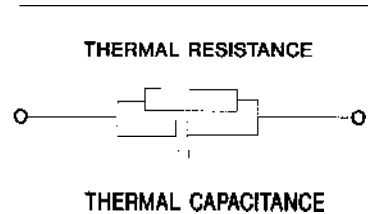

Thermal Capacitance Cth is a measure of the capability to accumulate heat, like a capacitor accumulates charge. For a given body, Cth depends on the specific heat-c, volume-v, and density-d, according to the relationship,

$$C_{th} = c \cdot D \cdot v$$

the resulting temperature increase ΔT when the body has accumulated the heat Q is given by

$$\Delta T = 1 \Delta Q / C_{th}$$

The thermal resistance Rth, quantifies the capability of a given path to transfer heat. The general definition of resistance of the thermal path includes the three different modes of heat dissipation, Conduction, Convection and Radiation.

Thermal Resistance Paths

Arrows - indicate conduction and radiation heat dissipation paths

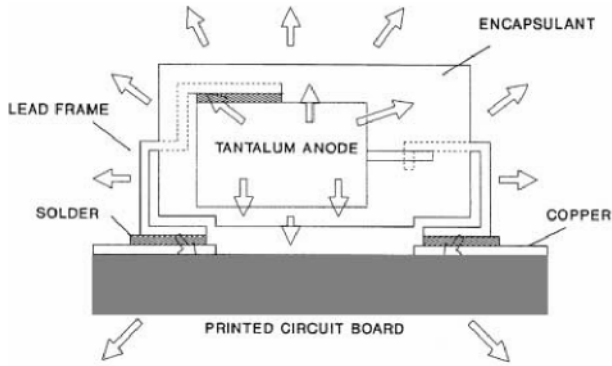

Figure 9. Thermal Dissipation from the Mounted Chip

The temperature increase above the reference and the heat flow is given by the equation

$$R_{th} = \frac{\Delta T}{\Delta P} = \frac{\Delta T}{\Delta Q / A \cdot t} \quad \text{where } \Delta Q = \text{heat}$$

$$\Delta t = \text{time}$$

To illustrate how each cell contributes to the thermal impedance of the assembled capacitor on the printed circuit board we have to examine each thermal path. The Tantalum anode which generates the heat by the ripple current $P = I^2 \cdot R$ as discussed earlier in this paper, and other paths which allow heat to flow, the equivalent circuit diagram as follows:

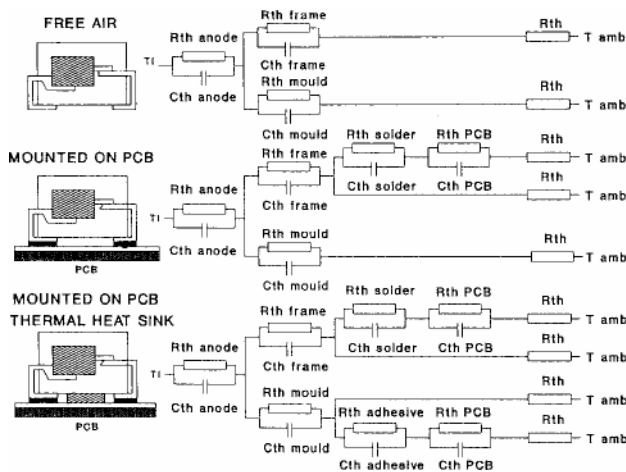

Figure 10. Dia Equivalent Thermal Circuit

Free Air

The thermal equivalent circuit for a capacitor in free air is a very simple model, the heat generated can be transferred through the body material and the lead frame to the ambient, and this is the dissipation data given in the manufacturers data sheet.

Capacitor mounted on a PCB

When the capacitor is soldered down to the PCB, the thermal path is changed in two ways. First the body surface exposed to free air is reduced, as the body surface facing the PCB will not have the same

thermal impedance as that of free air, secondly the heat transmitted through the leads can now be conducted to the PCB by the joint of the leads to the PCB. If this solder, it will have a very much better thermal impedance than that of conductive resin.

The PCB will also dissipate heat to the surrounding air.

Capacitor thermally mounted to the PCB

In the third equivalent thermal circuit diagram, a thermal compound has been added under the body of the capacitor, to simulate the adhesive used to hold the capacitor to the PCB. The thermal conductivity of the material will effect the thermal impedance of the assembly.

In order to quantify the significance of each of these thermal routes, the following tests were developed.

Two sample PCB 50mm square were designed, one with minimum copper, the other to have maximum copper over the surface.

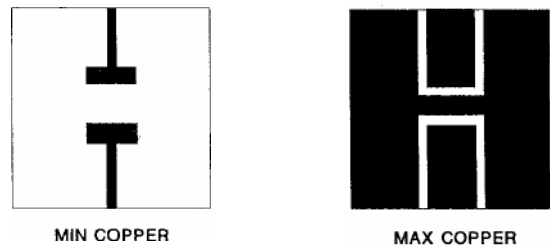

Figure 11. PCB Test Boards

Two areas of the design need explanation. The copper tracks connected to the leads of the capacitor were increased on the second board to study the effect of thermal transfer down the leads, also a copper track was placed under the capacitor, to study the effect of the heat flow through the capacitor body to the PCB.

Capacitors mounted as illustrated in the thermal diagram Figure 10 were electrically loaded, and the body temperature was measured by an infrared probe thus avoiding heat loss via the temperature measurement probe.

In order to illustrate the affect of each thermal path, I am going to review a case study on a "C" case size capacitor, to highlight the significance of each of the thermal paths.

First test was to define the thermal impedance R_{th} of the three equivalent circuits, Free air, Mounted on a PCB with min copper and mounted on a PCB with max copper with thermal compound between capacitor body and PCB.

In order to derive the thermal impedance of the "C" case size body, a capacitor was electrically broken

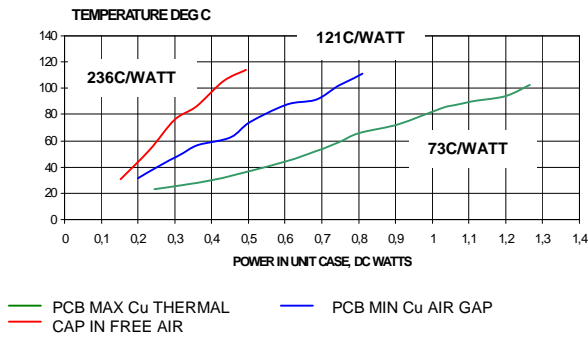

Figure 12. Thermal Impedance Graph - C Case Size

down by applying a reverse voltage, then increasing the d.c. power in the capacitor body and recording the body surface temperature. A plot of power to temperature was made for each of the three conditions, from these tests the Thermal impedance in deg C/Watt can be found. The results show clearly that significant changes can be made by the mounting method and the design of the PCB. The free air thermal impedance was 236 C/Watt, whereas the best mounting method was 73 C/Watt, a significant improvement.

To separate the variables a further test was made using a fixed power of 0.7 watts, and measuring the temp with time for the various methods of mounting. This will give the Cth for the various assemblies.

TEMPERATURE RISE WITH TIME FOR C CASE ELECTRICAL LOADING 0,7 WATTS.

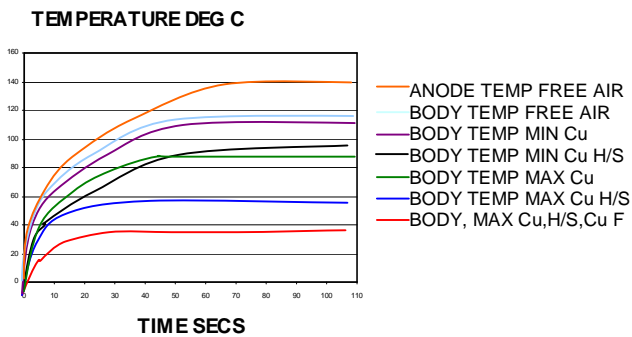

Figure 13. Temperature Rise with Time

The first measurement is the anode temperature within the resin body in free air. This was achieved by drilling a small hole through the resin body and focusing the infrared probe beam on the tantalum anode deep within the capacitor. The second measurement was taken on the outside surface of the resin molding. Results indicated that the temperature difference was 18c. The effect of mounting the capacitor on the PCB with the minimum copper only lowered the body temperature by 5c compared with free air. By adding the thermal compound between the capacitor body, a further 10c was achieved. Moving the capacitor to the PCB with the max copper at the termination solder joint gained a further 5c.

The surprising result came when the thermal compound was added between the capacitor body and the PCB coated with copper, giving a temperature drop of 15c.

The large drop in temperature when the capacitor body was thermally coupled to the copper on the PCB, and the small temperature drop obtained when the capacitor was soldered to the PCB, indicated that this was confirmed by calculation of the thermal conductivity of copper and Nio 42. Capacitors were then manufactured with copper terminations and the measured results confirmed a further 8c temperature drop.

All the above tests were made by d.c. current on the short circuit capacitor with 0.7 watts being dissipated within the capacitor body.

**TEMPERATURE RISE WITH RIPPLE VOLTAGE
5V AC RIPPLE, 1,5 AMPS RIPPLE CURRENT
C CASE SIZE, TEMP TOP OF BODY.**

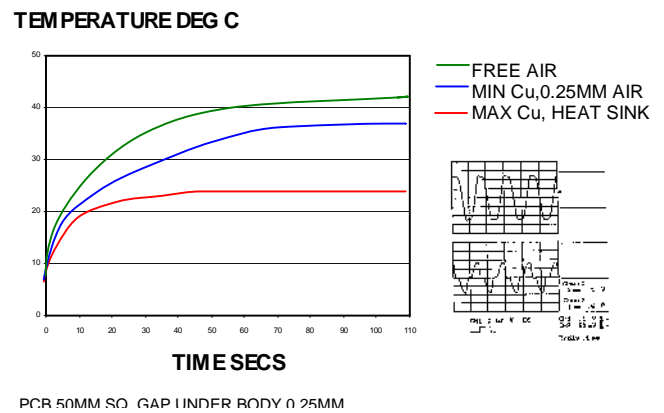

PCB 50MM SQ GAP UNDER BODY 0.25MM

Figure 14. Temperature Rise with Ripple Current

In order to relate these results to capacitors loaded with a.c. ripple current, a 20 volt rated capacitor was biased at 10v d.c. with a ripple voltage of 5v a.c. The feeding voltage generator was of low impedance allowing a 1.5 amp a.c. peak to peak current. Figure 14 illustrates the reduction in temperature in the capacitor due to the improved thermal design of the PCB and thermal heat sinking of the capacitor body to the PCB.

By plotting these results onto the thermal impedance graph Figure 8 it can be seen that the

**THERMAL IMPEDANCE GRAPH
C CASE SIZE CAPACITOR BODY**

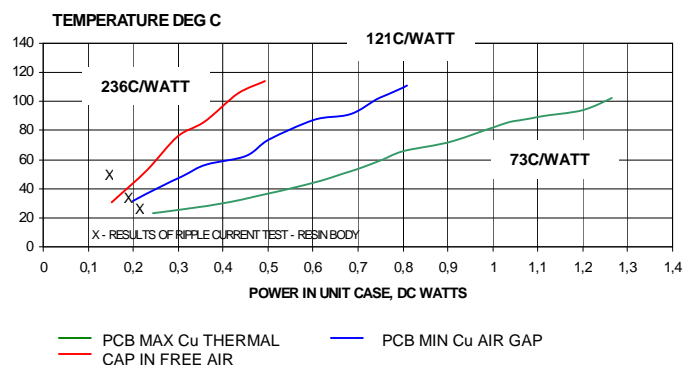

Figure 15. Thermal Impedance Graph with Ripple Current

power level of between 0.15 or 0.19 watts is being dissipated during this test. This illustrates the benefit of good PCB design, and making good thermal contact between the capacitor body and the PCB can significantly reduce the capacitor temperature rise above ambient, and improve the thermal capacitance C_{th} to minimize the temperature under pulse conditions.

It has been demonstrated that the larger capacitor is not affected to the same extent on mounting as the smaller capacitor, but what effect does the size of substrate have? In order to check this the printed circuit board was mapped using the infrared probe at 5mm intervals.

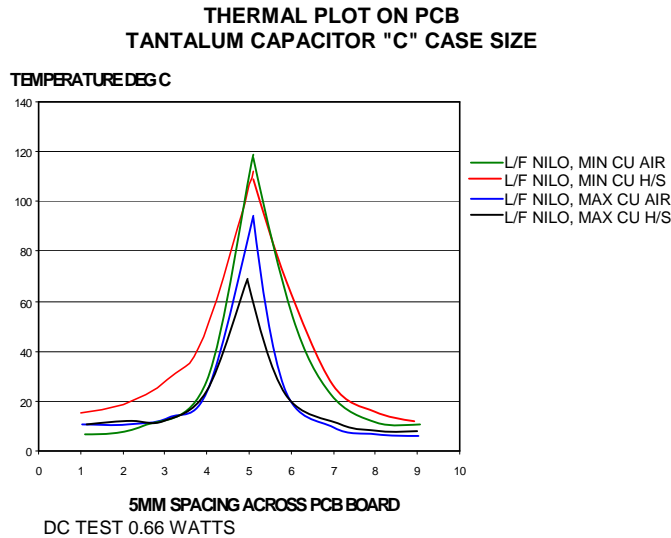

Figure 16. Thermal Plot Across Printed Circuit Board - C Case Size

From Figure 16 it can be seen that 80% of the temperature drop occurs within 5mm of the capacitor body, and the effect of the max copper PCB design reduced the temperature rise.

The next test was to measure the thermal impedance for different size boards, 10mm sq, 20mm sq, 30mm sq, 40mm sq, 50mm sq, and the results plotted of deg c per watt to PCB area.

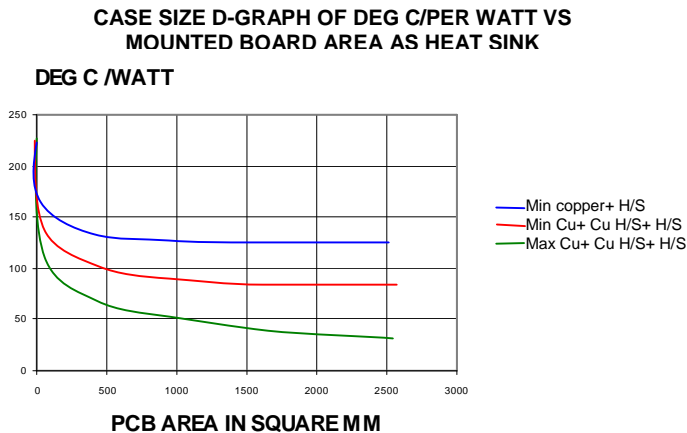

Figure 17. Thermal Rating to PCB Area

Summary

Results reported in this paper confirm that in applications where high power is dissipated within the capacitor, the design of the PCB and the thermal coupling of the capacitor to the PCB is very important in reducing thermal stress on the capacitor.

The thermal diagram above for the three methods of mounting, has had the temperature added for the anode, package and ambient. This clearly shows the significant reduction in temperature by the use of a copper heat sink on the PCB and the use of a thermal conductive adhesive for mounting the capacitor. Using this method of attachment, a reduction of 40% in the thermal stress can be achieved.

Thermal capacitance can be improved, so that the resulting temperature increase with time can be reduced, this is important in pulse applications as it reduces the thermal cycling stress within the capacitor body. To improve thermal design the following assembly design rules should be used.

1. Add a copper pad "radiator" on the PCB under the glue pad of the capacitor and extend this pad 5mm either side of the capacitor, using the maximum thickness of copper possible on the PCB.
2. Use a thermally conductive adhesive to hold the capacitor to the PCB, this will achieve a good thermal path from the capacitor body to the copper heat sink on the PCB.
3. Use the largest plan area device possible, to get a large area in contact with the PCB.

Using the above design rules the temperature increase of the capacitor will be reduced. This will also reduce the change in capacitance, DF, and Leakage current as these have a positive temperature coefficient. This will in turn improve the circuit stability under the operating conditions.

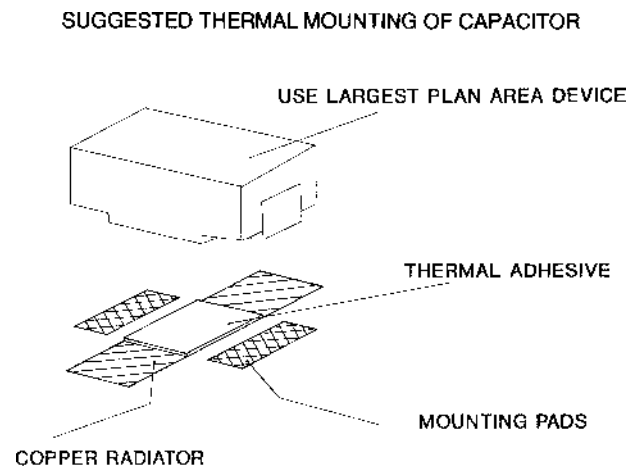

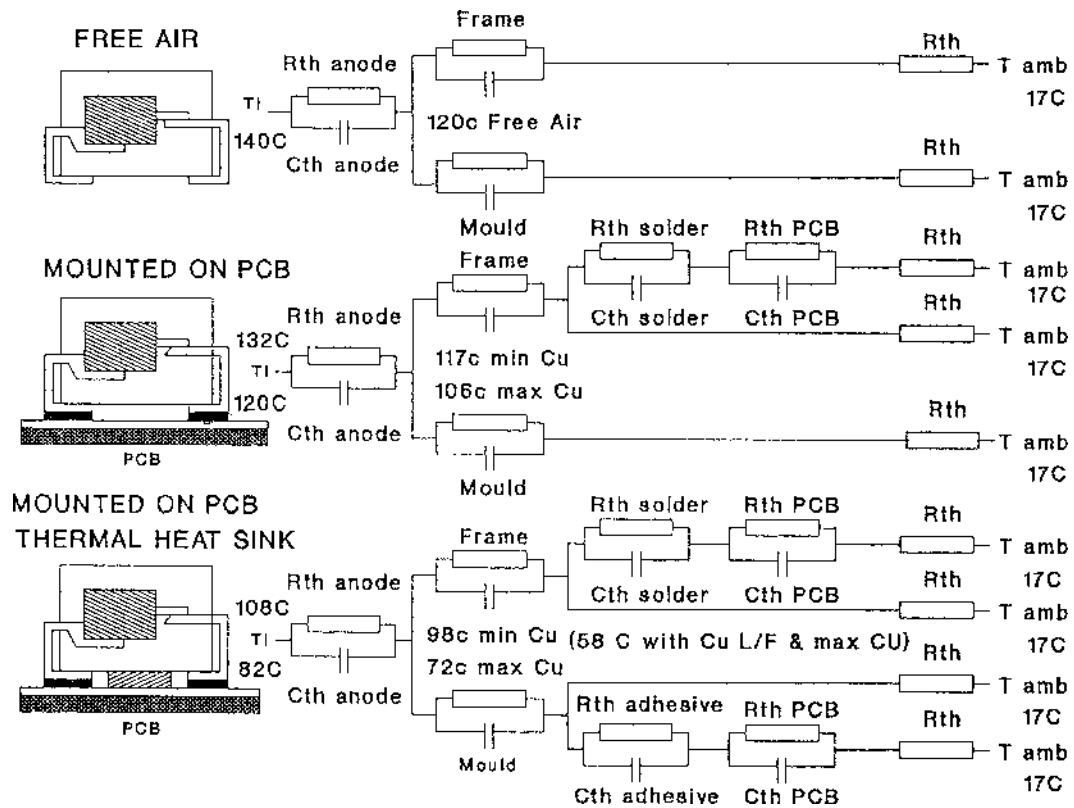

Figure 18. Equivalent Thermal Circuit with Temperatures

NOTICE: Specifications are subject to change without notice. Contact your nearest AVX Sales Office for the latest specifications. All statements, information and data given herein are believed to be accurate and reliable, but are presented without guarantee, warranty, or responsibility of any kind, expressed or implied. Statements or suggestions concerning possible use of our products are made without representation or warranty that any such use is free of patent infringement and are not recommendations to infringe any patent. The user should not assume that all safety measures are indicated or that other measures may not be required. Specifications are typical and may not apply to all applications.

© AVX Corporation