



EQUIPMENT SPECIFICATIONS AND CERTIFICATIONS MANUAL



Table of Contents

Bowling Ball Specifications	3	Regulation Bowling Lane	26
Material		Synthetic Products	
Surface		Composition Length	
Weight		Width	
Hardness		Surface	
Cleaning		Lane and Approach Markings or Designs	
Devices		Designs and Logos	29
Mechanical Aids		Special Events	
Ball Manufacturing Specifications	5	Non-commercial Centers (Universities, Fraternal, Military, and Other)	
Physical Specifications		Synthetic Bowling Lane	30
Marking		Identification	
Center of Gravity (CG) Marking Location		Gaps and Drop Off	
Approval Logos		Surface	
Drilling Specifications	6	Pin Deck Area	32
Holes		Composition	
Balance		Edge Boards	
Determining the Center of Grip		Synthetic Edge Strip	
Plugs and Designs		Synthetic Pin Decks	
Two-Handed Techniques	8	Pin Spots	
Two-handed Delivery		Tail Plank	
Two-handed Approach		Other Pit Area Specifications	35
Holes		Round Gutters	
Determining the Grip Center		Flat Gutters	
Bowling Ball Submittal Specifications	10	Reinforced Flat Gutters	
Bowling Ball USBC Requirements	11	Flat Gutter Molding (Solid Hardwood)	
Bowling Ball Testing Fee Schedule	11	Reinforced Flat Gutter Molding	
USBC Tenpin Specifications	14	Kickbacks	
Material		Kickback Plates	
Adhesives		Rear Cushion	
Finish and Coatings		Pit	
Coating Thickness		Technical Specifications for Fully-Automatic Pinsetting Devices	40
Synthetic Pin Core Filling		Technical Specifications for Automatic Scoring Device	
Synthetic Pin Balance		Technical Specifications for Automatic Foul Detecting Device	42
Synthetic Radius of Gyration		Lane Certification/Inspection	43
Synthetic Pin Center of Gravity		A. Application/Inspection	
Hardness Consistency		B. Issuance	
Design		C. Representation	
Durability		D. Retention	
Controlled Weight Pins	17	E. Penalty for Noncompliance	
Densified Tenpin	17	F. Noncompliance Procedures	
Bowling Pin Dimensions	18	G. Miscellaneous	
Bowling Pin Measurements	19	Lane Dressings and Lane Dressing Measuring Equipment	46
Bases		Technical Specifications for Lane Dressing	
Base Attachments		Technical Specifications for Lane Dressing Tape Take-Up Device	
Label and Marking		Lane Dressings and Lane Dressing Measuring Equipment	46
USBC ® Registered Service Mark		Technical Specifications for Ultraviolet-Sensitive Tape Reader	
New Pin Submission Timeframe		Lane Dressings and Lane Dressing Measuring Equipment	49
Pin Permit Renewal Timeframe		Manufacturers Field Test Program for Products	49
USBC Tenpin Approval Process	24	Manufacturers Field Test Program for Pins	50
Bowling Pin Testing Fee Structure	25		
USBC Process For Product Testing			
USBC Scoring Level Policy			

Bowling Ball Specifications

Any bowling ball used in USBC certified competition must be approved and identifiable as a ball listed in the "approved bowling ball" list located on the Equipment Specifications page on www.BOWL.com. Additionally, for identification purposes, each ball must have some form of serial number (this may be engraved or re-engraved by the bowler); the ball's original brand and product name logos must be engraved on each ball. No additional logos or designs may be added to a previously-approved ball without approval from the USBC.

Since all bowling balls manufactured prior to the creation of the ball list (January 1991) have been previously approved, the acceptance of the balls is at the discretion of the tournament director and/or league official.

Material

1. The ball shall be constructed of solid material i.e., no liquids and without voids in its interior.
2. Any material added to or included in the coverstock shall be equally distributed throughout the entire coverstock of the ball, except for materials used in logos and other required markings.
3. The density of any piece/component in a ball (e.g. core, coverstock, weight block, etc.) shall not exceed 3.80 g/mL (i.e., no pure metals or high density materials).
4. Following approval of the ball, the introduction of substances that are not comparable to the original material used in manufacturing of a bowling ball is prohibited. Likewise, altering a bowling ball in any way so as to increase its weight or cause it to be off balance outside the specifications is prohibited.

Surface

The surface of the ball shall be free of all depressions or grooves of specific pattern, except for holes or indentations used for gripping the ball, identification lettering and numbers, and incidental chipping or marking caused by wear. Engraved pictures, logos, and/or designs **from the manufacturer** are not considered grooves of specific pattern.

No foreign material may be placed on the outer surface of the ball.

If the surface friction of the ball is altered by sanding or polishing, the entire surface of the ball must be sanded or polished in the same manner.

Plugs, grips, and/or tape may not extend beyond the surface of the ball.

Weight

The weight of the ball shall not exceed 16.00 pounds. There is no minimum weight.

Hardness

1. The surface hardness of bowling balls shall not be less than 72 (measured with Shore durometer, type D) at room temperature (68-78 degrees Fahrenheit).
2. The use of chemicals, or other methods, to change the hardness of the surface of the ball after it is manufactured is prohibited.

Cleaning

Cleaners may be used provided:

1. They do not affect the hardness of the ball
2. They are totally removed from the ball before delivery

Any cleaner or polish that is used in certified competition must be approved by USBC and be found on the "Approved Cleaners and Polishes" list in the Equipment Specifications page on www.BOWL.com. All cleaning products must display the appropriate logo. (See figures 1,2)



Figure 1



Figure 2

Devices

Movable devices are not permitted in a ball except that a device for changing the finger span or the size of finger and thumb holes may be inserted, providing the device is locked in position during delivery and cannot be removed from the ball without destroying the device. (Excluding tape in a gripping hole.)

Removable devices shall be permitted provided:

1. Such devices are used for changing the span, pitch, or size of the gripping holes
2. Such devices are constructed of a non-metallic material
3. Such devices are locked in position during delivery
4. No device shall be employed for the purpose of adjusting the static balance of the ball
5. No voids shall be permitted under the device
6. Density does not exceed 1.5 g/mL

Mechanical Aids

A bowling ball must be delivered entirely by manual means and shall not incorporate any device, either in the ball or affixed to it, which is either detached at the time of delivery or is a moving part in the ball during delivery. Any person whose hand, or major portion thereof, has been amputated may use special equipment to aid in grasping and delivering the ball provided the special equipment is in lieu of the amputee's hand (see USBC rule book for further clarification).

Ball Manufacturing Specifications

The USBC Equipment Specifications and Certification Committee may establish specifications for a bowling ball as to roundness, size, materials, and physical properties. A manufacturer producing any new ball shall submit samples to the USBC Equipment Specifications Department for testing. Any re-released ball must meet all current specifications.

Physical Specifications

At time of manufacture, all balls must meet the following technical specifications when tested at room temperature (68-78 degrees Fahrenheit):

Specification	Minimum	Maximum
Circumference	26.704"	27.002"
Diameter	8.500"	8.595"
Roundness	None	0.010" total run out
Hardness	72	None
Radius of gyration**	2.460"	2.800"
Differential radius of gyration*	None	0.060"
Coefficient of restitution*	0.650	0.750
Coefficient of friction*	None	0.320
Mohs' Hardness	None	6.0
Surface Roughness – Ra	None	50 µin

*These specifications are for balls weighing 13.00 pounds or greater.

** This is a manufacturing design specification

Marking

Each ball must be uniquely identifiable by the following:

1. Brand name/logo
2. Ball name
3. Individual serial number
4. USBC star logo (As of March 1, 2006) Figure 3a

XYZ123
USBC★

USBC★
XYZ123

USBC★XYZ123

Figure 3a

Center of Gravity (CG) Marking Location

The center of gravity of an undrilled ball must be clearly identifiable by a unique mark or indicator.

Pin and Low RG Axis

The pin of a bowling ball indicates where the top of the weight block is within the ball. One end of the low RG axis of the ball should be located within a 1 inch radius of the center of the pin. Exceptions to this would include “pancake” type core designs.

Preferred Spin Axis (PSA), High RG Axis

The PSA is the axis about which a ball will migrate to and spin around when energy is added to the bowling ball; this will always be the high RG axis of the ball. For ball manufacturing specifications, this term applies to only undrilled balls with asymmetrical core designs. The PSA of a bowling ball should be clearly identifiable (if applicable) by a unique mark or indicator. The PSA should be within a 1.5 inch radius of the center of the marking or indicator on the ball. Balls with a measured intermediate differential of 0.000 in – 0.003 in should not have a PSA marking or indicator. A PSA marking or indicator is optional for balls with a measured intermediate differential of 0.004 in – 0.009 in. A PSA marking or indicator is required for balls with a measured intermediate differential of 0.010 in or greater.

Approval Logos

All boxes in which approved bowling balls are distributed must be clearly marked with the following approval logo which must be a minimum of 1 1/2” inches in diameter (See Figure 3b):

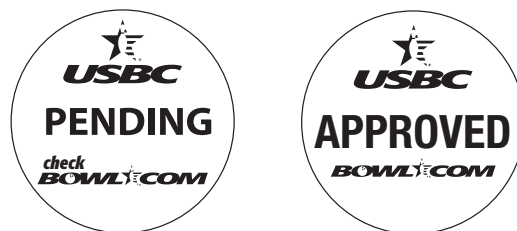

Figure 3b

Drilling Specifications

Holes

The following limitations shall govern the drilling of holes in the ball:

1. Holes or indentations for gripping purposes shall not exceed five and shall be limited to one for each finger and one for the thumb, all for the same hand. The player is not required to use all the holes in any specific delivery, but they must be able to demonstrate, with the same hand, that each hole can be used simultaneously for gripping purposes. Any hole that cannot be reasonably shown to be used with a single hand would be classified as a balance hole.
2. One hole for balance purposes not to exceed 1 ¼ inches in diameter. This hole may not exceed 1 ¼ inches at any point through the depth of the hole.

3. No more than one vent hole to each finger and/or thumb hole not to exceed 1/4 inch in diameter. USBC considers a vent hole to be any non-gripping hole that intersects with a gripping hole at any depth. Any hole intended for use as a balance hole that intersects with a gripping hole will instantly be considered a vent hole. This hole may not exceed 1/4 inch at any point throughout the depth of the hole.
4. One mill hole for inspection purposes not to exceed 5/8 inch in diameter and 1/8 inch in depth.

Balance

The following tolerances shall be permissible in the balance of a bowling ball used in certified competition:

1. 10.01 pounds or more:
 - a. Not more than three ounces difference between the top half of the ball (finger hole side) and the bottom half (side opposite the finger holes).
 - b. Not more than one ounce difference between the sides to the right and left of the finger holes or between the sides in front and back of the finger holes.
 - c. A ball drilled without a thumb hole may not have more than three ounces difference between the top half and bottom half of the ball.
 - d. A ball used without any holes or indentations may not have more than one ounce difference between any two halves of the ball.
2. For a ball weighing 10.0 pounds to 8.0 pounds:
 - a. Not more than two ounces difference between the top half of the ball (finger hole side) and the bottom half (side opposite the finger holes).
 - b. Not more than 3/4 ounce difference between the sides to the right and left of the finger holes or between the sides in front and back of the finger holes.
 - c. A ball drilled without a thumb hole may not have more than two ounces difference between the top half and bottom half of the ball.
 - d. A ball used without any holes or indentations may not have more than 3/4 ounce difference between any two halves of the ball.
3. For a ball weighing less than 8.0 pounds:
 - a. Not more than 3/4 ounce difference between the top half of the ball (finger hole side) and the bottom half (side of the finger holes).
 - b. Not more than 3/4 ounce difference between the sides to the right and left of the finger holes or between the sides in front and back of the finger holes.
 - c. A ball drilled without a thumb, without finger holes, or without any gripping holes or indentations may not have more than 3/4 ounce difference between any two halves of the ball.

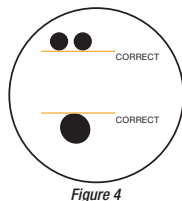

BLACK - THUMB/FINGER HOLES

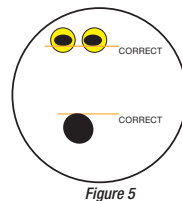

BLACK - THUMB HOLE OR INSIDE FINGER HOLES

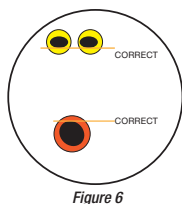

ORANGE -- THUMB SLUG OR SLEEVE
BLACK - INSIDE THUMB/FINGER HOLES

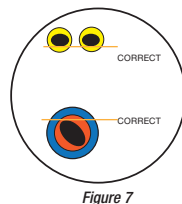

BLUE - INTERCHANGEABLE THUMB OUTER SLEEVE, IF PRESENT
ORANGE - INTERCHANGEABLE THUMB INSERT
BLACK - INSIDE THUMB/FINGERHOLES

Determining the Center of Grip

The center of grip is to be determined by measuring from the front edge of each finger hole to the front edge of the thumb hole. If more than two fingers holes are used, the center of grip will be determined by averaging the distance between each finger hole and the thumb hole. (See Figures 4, 5, 6, & 7.)

Plugs and Designs

1. Ball plug may be used for the purpose of redrilling a ball. A slug may only be used in place of plugging a thumb or finger hole. The hole drilled through the slug must be complete, leaving no void at the base of the slug.
2. In all cases, there shall be no interior voids.
3. Plugs and designs must be made of material similar to, although not exactly the same as, the original material out of which the ball was made. Plugs and designs must comply with other specifications of a bowling ball.
4. No foreign material may be placed on the outer surface of the ball or in the weight hole, including but not limited to tape, paint, or whiteout.
5. Density may not exceed 1.5 g/mL.

Two-Handed Techniques

Two-handed Delivery

Both hands impart force on the ball to get it down the lane; normally done by swinging the ball between one's legs. Differing greatly from the two-handed approach, this style is most commonly used when youth start to learn how to bowl. Individuals who deliver the ball from the chest using both hands would be considered to be using a two-handed delivery.

Two-handed Approach

Not to be confused with the two-handed delivery, this style places both hands on the ball and are left on the ball throughout the swing until the release. An evolution of the thumb-less technique, this can be done with or without the thumb on the dominant hand in the ball.

It's important as it relates to USBC rules regarding averages and drilling specifications to know which hand is the dominant hand. This is determined by the side of the body by which the ball swings and, if utilized by the player, the hand which is used to grip the bowling ball.

This particular style has been made popular as it enables the bowler to create additional revolutions.

Holes

The limitations governing the drilling of holes in the ball can be found on page 6. Note that for two-handed techniques, the holes or indentations for gripping purposes must be used and be capable of being used by the same hand.

Determining the Grip Center

The following eight examples show specifically how to determine grip center as it relates to two handed and thumbless bowling. Remember that all balance requirements as well as traditionally drilled bowling balls are listed on page 7.

Note: the ball must be in specification for balance and hole requirements as the ball rests in the bowler's hand. A ball may be in specification if oriented one particular way but not another. Compare Figures 11 and 14.

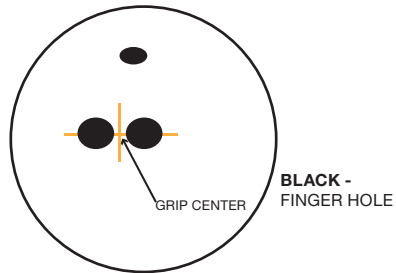

Figure 8

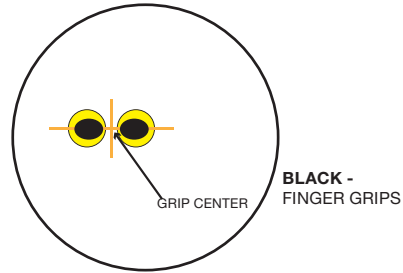

Figure 9

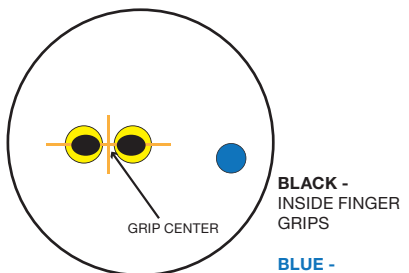

Figure 9

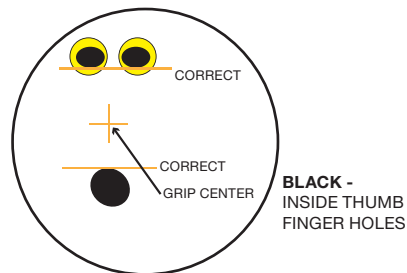

Figure 10

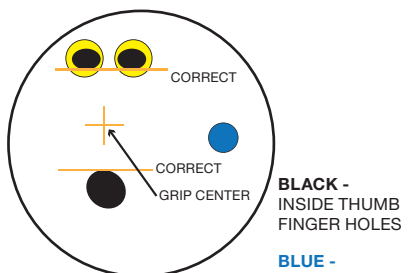

Figure 11

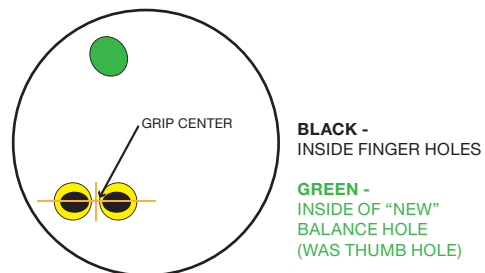

Figure 12 -ALLOWED FOR HOLE REQUIREMENTS, BUT MUST ALSO MEET PROPER STATIC WEIGHTS

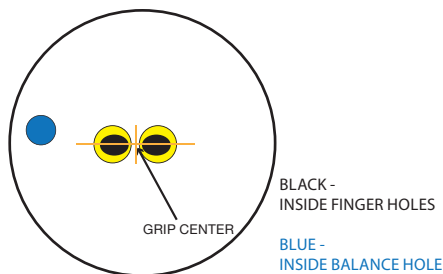

Figure 13

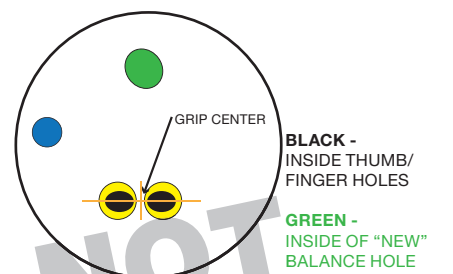

Figure 14

Bowling Ball Submittal Specifications

1. Bowling ball manufacturers shall comply with all USBC Equipment Specifications and Certifications Manual specifications in the production of balls for each brand produced and offered for sale, and assume responsibility for such compliance by any other individual, firm, corporation or agent authorized or licensed by the ball manufacturer to use the approved ball formula and manufacturing procedure on the manufacturers' behalf.
2. Manufacturers must submit two balls of the same model for testing. These balls are subject to the following requirements:
 - Weight:
 - One sample to be between 13.00 and 14.40 pounds
 - One sample to be at least 15.00 pounds
3. USBC possesses the right to announce ball approval and/or denial in its publications on www.BOWL.com or through any other media as USBC deems necessary to inform its members of any such action.
4. All boxes in which approved bowling balls are distributed must be clearly marked with the USBC approval logo. All published advertisements will include the USBC approval logo or approval pending logo. The approval pending logo shall be used advising USBC members that the ball is pending USBC approval and to check www.BOWL.com for its status.
5. Any USBC approved bowling ball may be revoked and withdrawn by USBC at any time by notice of cancellation or revocation to the ball manufacturer, in writing, at its last known address, when USBC determines that balls being produced do not comply with current USBC specifications and requirements in the USBC Equipment Specifications and Certifications Manual.
6. USBC may withhold approval of any bowling ball to preserve the essential character and integrity of the sport of bowling or for fairness of play. In addition, "USBC Approved" status may be revoked and withdrawn if USBC determines through testing and analysis of scientific data that such bowling balls may affect the essential character or integrity of the sport of bowling or fairness of play. In the event of a withdrawal, the ball manufacturer shall terminate production and distribution of any ball marketed as "USBC Approved" as of the date determined by USBC. The ball manufacturer will be responsible to pay for outside laboratory fees when additional, independent, scientific testing and analysis is required.
7. All product testing and approval is specific to that particular place of manufacture. If manufacturing of a previously approved product changes locations, that equipment must be re-tested. All testing fees shall apply. Any equipment which has shifted manufacturing facilities shall be deemed unapproved until the completion of testing by USBC. Any equipment release prior to USBC approval shall be subject to fines as outlined in the Bowling Ball Testing Fee Schedule.
8. Allow 15 business days for bowling ball approval.

Bowling Ball USBC Approval Requirements

1. Each ball model submitted for approval must meet all of the physical specifications. Additional testing for balls that fall within specified ranges on certain physical specifications will be required as follows:
 - a. Coefficient of friction (for balls weighing 13.00 pounds or greater)
 - i. Eight additional balls must be submitted (specific weight to be determined by USBC) for balls with a measured coefficient of friction between 0.290 and the maximum 0.320.
 - ii. All eight additional samples must be below the maximum coefficient of friction specification of 0.320.
 - b. Coefficient of restitution
 - i. Eight additional balls must be submitted (specific weight to be determined by USBC) for balls with a measured coefficient of restitution between 0.739 and the maximum of 0.750.
 - ii. All eight additional samples must be below the maximum coefficient of restitution specification of 0.750.
 - c. Radius of gyration
 - i. Eight additional balls must be submitted (specific weight to be determined by USBC) for balls with a measured radius of gyration between the minimum of 2.447" and 2.473" or between 2.787" and the maximum of 2.813".
 - ii. In the case of low end of the specification, the average radius of gyration (about a specific axis) of all samples of similar weight must be no lower than 2.460". In the case of the high end of the specification, the average radius of gyration (about a specific axis) of all samples of similar weight must be no higher than 2.800".
 - d. Differential radius of gyration – for brand new core designs only
 - i. Eight additional balls must be submitted (specific weight to be determined by USBC) for balls with a measured differential radius of gyration between 0.050" and the 0.061".
 - ii. The average differential radius of gyration of all samples of similar weight must be no higher than 0.055" for the ball to be approved without participation in the optional supplemental testing process.
 - iii. If through the supplemental testing process it can be proven that balls are not designed above the maximum specification of 0.060" and have less than 0.6% rate of non-conforming balls, the ball will be approved.
 - e. Surface Roughness
 - i. Eight additional balls must be submitted (specific weight to be determined by USBC) for balls whose measured surface roughness, Ra, is between 42 μ in and 65 μ in.
 - ii. The average surface roughness of all samples of similar weight must be less than the maximum surface roughness specification of 50 μ in.
2. Each ball model submitted for approval must meet all of the marking specifications. Additional testing for balls that do not meet the marking requirements is as follows:
 - a. Pin and Low RG axis
 - i. Eight additional balls must be submitted (specific weight to be determined by USBC) for balls whose low RG axis is not within a 1" radius of the center of the pin.
 - ii. All eight additional samples must have the low RG axis within a 1" radius of the center of the pin.
 - b. PSA and High RG axis
 - i. Eight additional balls must be submitted for balls where the center of the PSA marking is not within a 1.5" radius of the high RG axis of the ball.
 - All eight additional samples must have the high RG axis within a 1.5" radius of the PSA marking.

- ii. Eight additional balls must be submitted for balls that have a PSA marking and the measured intermediate differential is 0.000" - 0.003".
 - All eight additional samples must have an intermediate differential of 0.000" - 0.003" and the PSA marking removed or have an intermediate differential of 0.004" or greater.
 - iii. Eight additional balls must be submitted for balls that do not have a PSA marking and the measured intermediate differential is 0.010" or greater.
 - All eight additional balls must have a PSA marking that is within a 1.5" radius of the high RG axis or an intermediate differential of 0.003"-0.009".
 3. Balls which are not approved based on marking requirements only may be corrected and resubmitted for approval. For pin and Low RG axis resubmissions, the corrected ball must be submitted with a different color pin. Balls which are not approved will not be reconsidered for approval unless the ball is resubmitted with a name and/or significant color change. Balls resubmitted must meet all current specifications. In addition, one of the following changes must occur:
 - a. Core/Weight block design change
 - b. Coverstock change
 4. Authority for approval or rejection of bowling balls is vested in the USBC Equipment Specifications Department based solely on the test results. If a manufacturer wishes to dispute the decision on a bowling ball, the issue may be appealed to the USBC Equipment Specifications and Certifications Committee within 30 days. The committee will make their final decision at the next scheduled meeting.

Bowling Ball Testing Fee Schedule

1. All bowling balls intended for use in any USBC certified competition shall be submitted for and required to obtain USBC approval prior to use in any USBC certified competition. All bowling balls produced and offered for sale to USBC members for use in certified competition shall comply with current USBC specifications and requirements.
2. A USBC Equipment Specification Bowling Ball Application Sheet must accompany all bowling balls submitted for approval.
3. The following fees apply to bowling ball testing:

Testing

- a. Basic test fee for initial approval: \$400 per ball (13-16 pounds)
- b. Basic test fee for balls manufactured only under 13 pounds: \$200
- c. Balls needing additional testing prior to approval:
 - i. Surface Roughness: \$500
 - ii. Total Differential / COR / RG (more than one axis): \$400
 - iii. COF / RG (1 axis)/ other: \$350
- d. Balls tested on an expedited basis: \$1,000
- e. Non-high-performance balls (plastic, polyester) that are manufactured by the same manufacturer and are previously approved for another brand: \$100

Regulation

- a. Fees for balls released prior to USBC approval: \$4,000 per ball plus any amounts expended to correct the non-compliant ball release, any damages incurred by USBC together with any legal fees incurred by USBC
- b. Fees for failure to identify a USBC approved ball with either the USBC approval or pending logo in any advertisement, bowling publication or other: \$750 per occurrence plus any legal fees incurred by USBC
- c. Fees for identifying, in a bowling publication or other or on any ball or ball box, a ball as USBC approved when it is not: \$750 per occurrence plus any legal fees incurred by USBC
- d. Fees for any ball found to not have the same core and/or coverstock as that which was previously approved: \$4,000 per ball plus any amounts expended to correct the non-compliant ball release and any legal fees incurred by USBC
- e. Fees for any second quality ball (X-Comp, X-Blem, X-Out, etc.) found to not have the same core and/or coverstock as the original first quality model: \$4,000 per ball plus any legal fees incurred by USBC
- f. Fees for any ball found to not have the same required markings (Figures 3a and 3b) as that which was previously approved: \$2,000 per ball plus any amounts expended to correct the non-compliant ball release and any legal fees incurred by USBC

Notes

Late fee charge of 1.5% per month will apply for all outstanding invoices not paid within 30 days.

4. The ball manufacturer will be responsible for all shipping costs, including the return of additional test balls when required.

5. Failure to remit payment in a reasonable amount of time will result in revocation of approval status and cessation of approval testing on new products.

USBC Tenpin Specifications

Material

- A. USBC approved pins shall be made of new (unused), sound, hard wood and must comply with all technical specifications.

Editor's Note: *Sound means the wood shall be free of any decay that has advanced to a point where it can be recognized by color or softening of the wood and shall not have the following defects:*

1. Cracks due to drying of the wood
 2. Skip, torn or chipped grain in ball zone exceeding a two-square-inch area or having a maximum depth greater than 1/8 inch
 3. Open glue joints in laminated pins due to either uneven facing surfaces, inadequate glue pressure or poor gluing
 4. Cross grain exceeding slope of 1 inch in 10 inches
 5. Knots and bark pockets with maximum dimension exceeding 1/4 inch in neck, 3/8 inch at pin bottom, 1 inch in head and 1 3/4 inches in ball zone
 6. Each pin may be constructed of one piece, or two or more laminated pieces, provided that all lamination runs parallel to the vertical axis of the pin.
- B. Any pin that is not made of wood shall be classified as synthetic and must be submitted to USBC for testing and approval before it can be used in certified competition. Approval agreements of any synthetic pin must be manually signed by an authorized company representative and countersigned by a designated USBC officer.
 1. Manufacturer's specifications for (type of pin) dated to produce following or additional physical properties: type of material tensile strength p.s.i., tear min. die (ASTM), elongation min., modulus of compression min. (at percent), scleroscope hardness min/max/mean (Hardness values effective after hours, or days mold, air, or forced cure time.) test on Shore (Model C-2) scleroscope with diamond head hammer. Calculations obtained from average of 10 readings varying 1 to 1.5 inches apart at 4 3/4 inches above the pin base.
 2. Thickness (if applicable): individual measurement points, amount and tolerances to be established by laboratory test and mutual agreement.

Adhesives

Adhesives used in laminating pins should be of such types that they will withstand the forces of temperature, moisture and play that occur in service of a bowling pin, and they should be sufficiently durable to provide satisfactory quality joints during the life of the pin. Only adhesives conforming to the quality required by commercial standards, or federal specifications for the appropriate adhesive, should be used.

It is advisable to obtain certification from the adhesive manufacturer that the adhesive is accept-

able for laminating wood for bowling pins.

The bonding quality of the glue must not be affected by any process presently being used in the manufacture of any USBC approved plastic-coated pins.

Mixing, spreading, storage, working and assembly life should be in accordance with the manufacturer's recommendations.

Each lot of adhesive should be certified as conforming to the applicable specifications.

Gluing procedures should conform to those described in the Forest Products Laboratory (U.S. Department of Agriculture) manual entitled "Fabrication and Design of Glued Laminated Wood Structural Members."

Finish and Coatings

Pins used in USBC certified competition shall only bear the name and trademark of the original manufacturer or distributor and be marked "USBC Approved." Except for reasonable wear, neck markings and color, the pins in each set must be uniform in appearance including finish and labels.

The coating shall be solid color and/or transparent (clear) with the exception of neck markings, identifications symbols and names, which must be contrasting color. The material shall establish, upon laboratory test and mutual agreement, its own physical property specifications, some of which may include: tensile strength, yield, tear, elongation, hardness and others if applicable.

At no time may a pin be painted or any supplemental finish be applied that has not been evaluated and approved by USBC.

Note: For permit renewals, all coatings and finish materials must meet a percent similarity specification. If pins fail to meet these specifications, USBC will conclude the pin is a different pin than was initially submitted, therefore denying permit renewal.

Coating Thickness

Coating thicknesses of plastic-coated pins will be developed independently with each manufacturer. These tolerances are individually applicable at the head, neck, ball line and base locations based on the average of 10 equidistant measurements around the pin. In addition, the measured coating must fall within the maximum/minimum tolerance for each of the 10 measurements.

Coating Average	Tolerance
0.001-0.075"	± 0.015"
0.075-0.100"	±0.020"
0.101 and greater	±0.025"

Synthetic Pin Core Filling (if applicable)

Physical properties	Tensile strength
Material	Yield p.s.i.
Weight of fill material as oz plus/minus oz	Tear p.s.i.
Density	Elongation percent

Synthetic Pin Balance

Pins to be balanced around the vertical axis with a maximum tolerance of five grams

Synthetic Radius of Gyration

Pins will set their own radius of gyration and tolerance based on the samples submitted at time of testing provided the tolerance does not exceed plus/minus 0.094 inch.

Synthetic Pin Center of Gravity

Pins will set their own center of gravity and tolerance based on the samples submitted at time of testing provided the tolerance does not exceed plus/minus 5/32 inch.

The manufacturer of pins described herein shall have a device approved by USBC to pinpoint the exact center of gravity. A daily spot check of pins in production to ensure specification compliance is mandated.

Hardness Consistency

Hardness determinations of the coating shall be established by a scleroscope hardness test. Minimum and maximum hardness values shall be established for each specific plastic coating, which shall be calculated from 10 measurement readings from 1 to 1.5 inches apart at the largest diameter on the pin, 4.75 inches above the pin base. The specification for each pin will be set at the average of these readings with a tolerance of plus/minus 10.

Design

The top of the pin shall have a uniform arc with a radius of 1.273 inches. A plus/minus tolerance of 1/32 inch shall be permitted. The taper from station to station shall be gradual so that all lines have a graceful curve.

Durability

Field tests by USBC must indicate that newly submitted pins will remain in play for at least 1,000 impact games per set if they are wood core and 2,000 impact games per set if they are synthetic. An impact game is predicated on usage in automatic pinsetting devices using 20 or 21 pins, i.e. each 10 frame game is equal to ½ impact game.

Wood core:

Coating loss at the ball line not to exceed 5 percent
Breakage not to exceed 2 percent at the neck

Synthetic:

1. Breakage not to exceed 5 percent in the area from the shoulder to and including the base
2. Breakage not to exceed 2 percent at or above the neck

Controlled Weight Pins

Controlled weight pins may be classified as USBC approved upon compliance with the following requirements:

1. To control the weight of wood core tenpins in order to provide uniformity within applicable weight requirements, the pin may be constructed with voids in its core, provided that such voids do not affect the pin balance around the longitudinal axis or appreciably alter pin performance characteristics through its normal life. The pin must otherwise conform to all specifications for a wood core plastic-coated pin.
2. Any void in a pin must extend through the center block. If not, the void must be balanced by an equal and oppositely placed void on the same axis and such axis must not be oblique to the longitudinal axis.
3. The manufacturer shall employ a USBC accepted device to check such pins accurately for center of gravity tolerances.
4. Spot checks of pins in production shall be made daily to ensure that they meet specification.

Densified Tenpin

A bowling pin shall be classified as densified when by a separate manufacturing operation, it has an area or areas where the wood is compressed, or impregnated and compressed, and the wood is stabilized at the increased density so that it does not recover at the relative humidity that occurs in service. The density shall be increased sufficiently so that the hardness (as measured by the Janka ball test, ASTM D-143-52, Sections 83-87) of the densified portion shall be at least 75 percent more than the undensified wood of the same pin.

The hard wood used in such modification in the ball line area must meet USBC material criteria. All densified tenpins must meet the USBC specifications for wood core plastic-coated pins.

Bowling Pin Dimensions

STATION	SPECIFICATION	TOLERANCE	
		Maximum	Minimum
13 1/2" Above Base	Diameter 2.547"	2.578"	2.516"
12 5/8" Above Base	2.406"	2.437"	2.375"
11 3/4" Above Base	2.094"	2.125"	2.063"
10 7/8" Above Base	1.870"	1.901"	1.839"
10" Above Base	1.797"	1.828"	1.766"
9 3/8" Above Base	1.965"	1.996"	1.934"
8 5/8" Above Base	2.472"	2.503"	2.441"
7 1/4" Above Base	3.703"	3.734"	3.672"
5 7/8" Above Base	4.563"	4.594"	4.532"
4 1/2" Above Base	4.766"	4.797"	4.735"
3 3/8" Above Base	4.510"	4.541"	4.479"
2 1/4" Above Base	3.906"	3.937"	3.875"
3/4" Above Base	2.828"	2.859"	2.797"
Base – with 5/32" radius – Flat Diameter	2.031"	2.062"	2.000"

OTHER SPECIFICATIONS	SPECIFICATIONS	TOLERANCE	
		Maximum	Minimum
Weight		3 lbs, 10 oz	3 lbs, 6 oz
Height	15" (15.000")	15.031"	14.969"
* Hole Depth (Standard, not specification)	2" (2.000")	2.031"	1.969"
Hole Size 27/64" (0.422")	0.453"	0.406"	
* Cup Diameter (Standard, not specification)	3/4" (0.750")	0.781"	0.734"
Radius at Base	5/32" (0.156")	0.187"	0.125"
Center of Gravity	5 15/16" (5.781")	5.937"	5.625"
		5 15/16"	5 5/8"
Radius of Gyration	13.90"	13.20"	14.60"
Moisture Content		12%	6%
Coefficient of Restitution	0.670"	0.735"	0.605"
Pin Coating Thickness	>0.004"		

Approved by the Equipment Specs Committee and effective May 1, 2010, the new specifications are as follows:

	PIN BASE	PIN COAT	CLEARCOAT
	% OF SIMILARITY	% OF SIMILARITY	% OF SIMILARITY
Acceptance Specification	95.75	92.50	95.00
Warning Specification	96.50	94.00	95.50

Bowling Pin Measurement Specifications

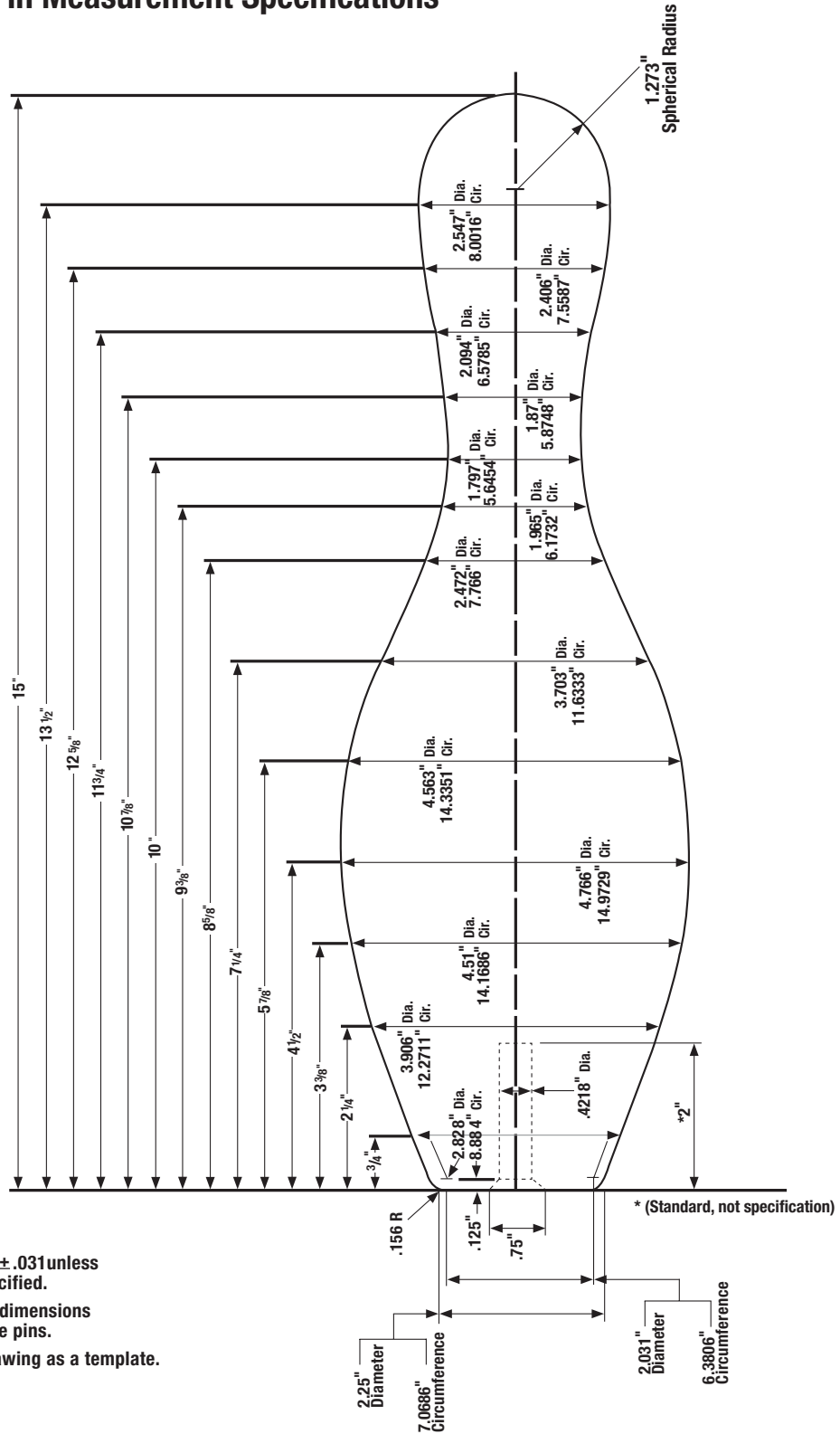

- All tolerances ± .031 unless otherwise specified.
- Use indicated dimensions to manufacture pins.
- Do not use drawing as a template.

Figure 15

Bases

No part of the base shall protrude beyond the base attachment, but that portion of the base within the base attachment may be recessed as much as .025 inches. As an alternate specification, the area of the base within the base attachment may be concave so that it is recessed at least .025 inch at the junction with the base attachment, gradually declining toward the center to a depth of .125 inch. When any portion of the pin protrudes beyond the base attachment, such pin is unacceptable for USBC certified competition until necessary corrections have been made to comply with the foregoing specifications.

All pins shall be rounded at the outer edge of the base by the manufacturer on a $\frac{5}{32}$ inch (.156) radius with a plus or minus tolerance of $\frac{2}{64}$ inch (.031). The diameter of the base, exclusive of the rounded edge, shall not be less than two inches. For the life of the pin, any base diameter less than two inches is unacceptable for USBC certified competition.

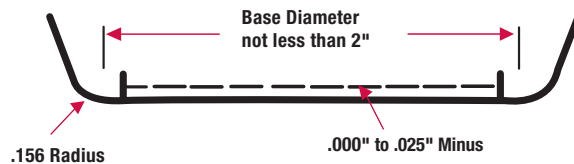

Figure 16

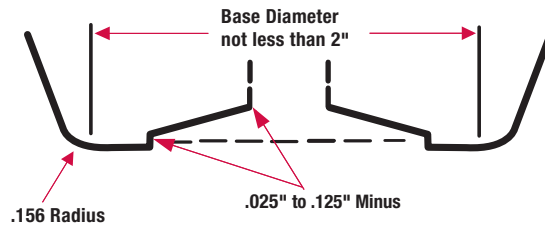
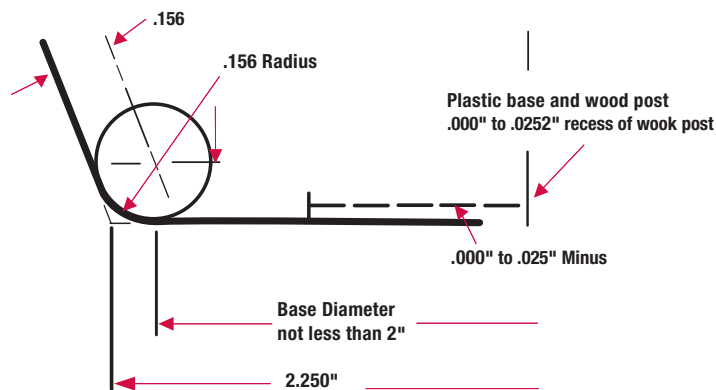

Figure 17



Pivot point of .156" radius is located .156 from bottom and side of pin as shown. So arc is tangent to both bottom and side of pin

Figure 18

Base Attachments

Base attachments must be USBC approved and manufactured in accordance with the specifications established by the USBC Equipment Specification and Certification Committee (see specs for Base Attachments).

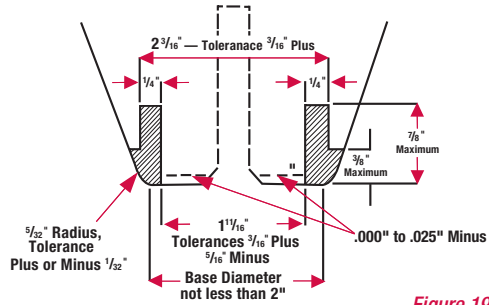

Figure 19

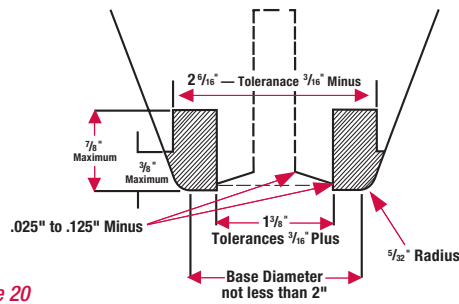

Figure 20

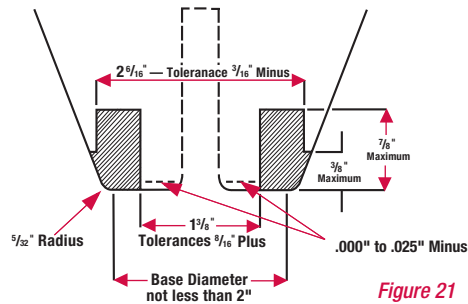

Figure 21

Label and Marking

Pins manufactured for USBC certified competition shall bear the name and trademark of the original manufacturer or distributor and be marked "USBC Approved." All pins shall bear two labels for the life of the pin. One half of the pin shall be the designated area for a manufacturer's label and it shall include the following items in its design:

1. The trade name.
2. The USBC Permit Number under which USBC approval was authorized.
3. The USBC Certification Mark in a size measuring at least $\frac{3}{4}$ inch in diameter.
See Certification Mark below.

The following designation (in full or acceptable abbreviation form) must appear on the manufacturer's label when applicable:

1. "Controlled Weight"
2. "Densified"
3. "Plastic Coated"
4. Reference to type of reinforcement (i.e. "nylon reinforced")
5. Synthetic

Manufacturers or distributors shall use a distinctive label, reserved exclusively for pins meeting USBC specifications. In addition to the manufacturer's label, a second label shall be a special "USBC Label" made in conformity to design provided by the USBC. It shall be affixed diametrically opposite the manufacturer's label and not measure less than 2" in diameter.



Figure 22



Figure 23

USBC[®] Registered Service Mark

United States Bowling Congress is the owner of the following certification marks applied to tenpins by the manufacturer to certify the tenpins meet USBC specifications.

Tenpins having the proper certification mark are approved for use in certified USBC competition.

1. Applies to all tenpins



Figure 24

2. Applies to approved plastic-coated wood tenpins



Figure 25

3. Applies to approved synthetic tenpins



Figure 26

4. Applies to all test pins



Figure 27

New Pin Submission Timeframe

May 1 – Letter of intention to test must be submitted to USBC. Products must be in USBC testing area at the same time.

May 15 – Pins must pass threshold and ramp tests.

August 1 – All products being tested must be installed.

Pin Permit Renewal Timeframe

June 1 – Any pins received after this date will be subject to an expedited fee.

July 31 – This is the last day for approvals for the upcoming season. Any pins received after this date will be approved for the following season.

USBC Tenpin Approval Process

Any pin used in certified competition must have a permit number.

The USBC possesses the right to spot check pins during the course of the year. USBC approval may be revoked if it is determined that the production pins are significantly different than the submitted test pins being produced or do not comply with current specifications and requirements in the USBC Equipment Specifications and Certification Manual.

New Pin Submission

- Completed application
- Four pins submitted for threshold testing
- 40 pins submitted for Bowl Score testing
- Adequate number of pins to complete field testing (See USBC Process for Product Testing)

Permit Renewal and/or Label Change

- Completed application
- Four pins submitted for threshold testing

Manufacturers With Change Of Address Or A Production Lapse Of Greater Than Six Months

- Completed application
- Four pins submitted for threshold testing
- 40 pins submitted for Bowl Score testing

Bowling Pin Testing Fee Structure

1. All bowling pins intended for use in any USBC certified competition shall be submitted for and required to obtain approval prior to use in any USBC certified competition. All bowling pins produced and offered for sale to proprietors for use in certified competition shall comply with current USBC specifications and requirements.
2. A USBC Equipment Specification Bowling Pin Application Sheet must accompany all bowling pins submitted for approval.
3. The following fees apply to bowling pin testing:
 - Testing
 - a. Threshold testing per permit number
 - i. Basic fee: \$400
 - ii. Expedited fee: \$1,000
 - b. Pins needing additional testing prior to approval:
 - i. Bowl Score: \$1,000
 1. Bowl Score expedited fee: \$2,000
 - ii. COR: \$45 per pin
 - iii. RG: \$45 per pin
 - c. Field test: \$5,000 fee
 - i. Manufacturer must pay for the full set of control pins
 - ii. Manufacturer must pay for the full set of test pins
 - Regulation
 - a. Fees for pins released prior to USBC approval: \$4,000 per permit number plus any amounts expended to correct the non-compliant pin release and any damages incurred by USBC
 - b. Fees for failure to identify a USBC approved pin with either the USBC approval or test pin logo in any advertisement, bowling publication or other: \$750 per occurrence plus any legal fees incurred by USBC
 - c. Fees for identifying, in a bowling publication or other, a pin as approved when it is not: \$750 per occurrence plus any legal fees incurred by USBC

NOTE: Late fee charge of 1.5% per month will apply for all outstanding invoices not paid within 30 days.

4. The pin manufacturer will be responsible for all shipping costs, including the return of additional test pins when required.

USBC Process For Product Testing

1. Official test may be conducted in any Dallas/Fort Worth area commercial center agreeable to the proposer and USBC provided that at least 250 bowlers conduct their schedule on the same group of lanes.
2. The test product is to be installed on pairs of lanes which coincide with the selected leagues. Installation can be side by side or staggered at the option of the proposer.
3. The leagues selected for durability data must bowl at least 28 weeks, which will provide for lane schedule equity of all teams.
4. Scoreability data will be compiled weekly in the following manner:
 - a. Computer input will record all scores on a weekly basis
 - b. Scoring comparisons are based on the average of a minimum of 250 individual bowlers who complete a minimum of 12 games on both the test product and the approved (control) product
5. Product acceptability is based on the test product qualifying within the criteria adopted as "USBC Scoring Level Policy for Approval."
6. Test specifications including lane maintenance procedures, product and lane dressing evalua-

tions shall be agreed upon by the proposer and USBC prior to commencement of the test.

USBC Scoring Level Policy

250 bowlers must complete 12 or more games on the control products and the test product.

Bowler's averages on the test product and control product are arranged side by side, and the mean difference in average between the test product and control product is calculated.

The data is tested for normality in order to determine the statistical test used:

- Data is normally distributed – Paired-t Test
- Data is not normally distributed – Wilcoxon Signed Rank Test

Statistical test is evaluated for two criteria:

- The mean of the difference must fall between -3 and +2
- The confidence interval around the mean of the difference must include 0

The product will pass provided the two statistical criteria are met.

Regulation Bowling Lane

A regulation bowling lane, including flat gutters, kickbacks and approach, must be constructed of wood and/or other materials which have been tested according to USBC procedures for the specified time period and approved.

Note: For areas beyond the pin deck not covered in the USBC Equipment Specifications and Certification Manual, standard installation procedures are acceptable unless, upon inspection, it is deemed that an area in question may affect specifications and/or scoring. In these instances, the USBC Equipment Specifications and Certification Department should be contacted.

Synthetic Products

All non-wood material used in the manufacturing of lane components must be presented to USBC for evaluation and possible testing before use in certified competition. If approved, they may not be altered by the use of coatings, etc. unless these coatings have been presented to USBC for evaluation and possible testing. In addition, all products must contain an approval label with the following requirements:

1. The label must be permanent, lasting the life of the product.
2. The label must be clearly visible after the product is installed in the bowling center.
3. The label must identify the company as the manufacturer.
4. The label must contain an approval number assigned by USBC and state that it is "USBC Approved."

Approach

Extending from and exclusive of the foul line there shall be an unobstructed level approach which shall be:

1. Not less than 15 feet in length.
2. Free from depressions exceeding 1/4 inch.
3. Not less than the width of the lane.

Foul Line

The foul line shall be:

1. Not less than 3/8 inch nor more than 1 inch in width.
2. At a minimum, the entire width of the lane.
3. Distinctly marked upon or embedded between the lane and approach.

It may be required the the foul line be plainly marked on the walls, posts, division boards or any point on a line with the regular foul line.

(For more information on the foul line see the section on Automatic Foul Detecting Device.)

USBC Regulation Bowling Lane Dimensions

Typical Cross Section of Bowling Lane — Round Gutters from foul line to pin deck area.

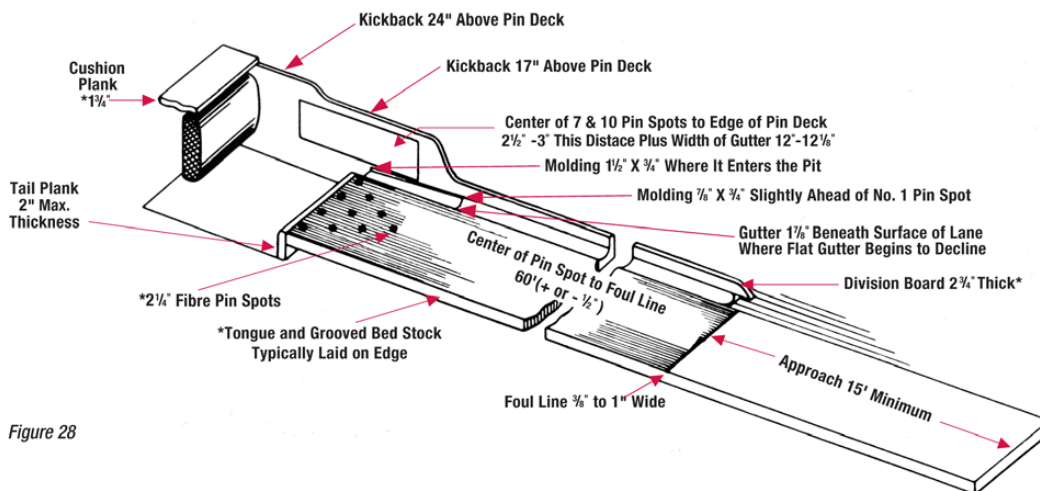

Figure 28

* NOTE: This particular measurement is not an USBC specification but is an accepted Standard for installing bowling lanes.

Composition

The lane must be constructed entirely of wood and/or synthetic materials which have been approved by USBC.

Length

1. The overall length of a regulation lane, including the pin deck, has a reference dimension of 62 feet, 10 3/16 inches, measured from the lane side of the foul line to the rear edge of the pin deck (not including the tail plank).
2. It must be 60 feet, plus/minus 1/2 inch, from the lane side of the foul line to the center of the No. 1 pin spot.
3. It must be 34 3/16 inches, plus/minus 1/16 inch, from the center of the No. 1 pin spot to the rear edge of the pin deck (not including the tail plank).

Width

The lane shall be 41 1/2 inches, plus/minus 1/2 inch, wide.

Surface

1. The surface must be free of all continuous grooves or ridge.

2. On the surface of the lane/panel for all initial installations, there shall be a limit of 40/1000 of an inch over a 42-inch span for each of the following:
 - a. Crosswise Measurements
 - i. Crosswise Tilt
 - ii. Crowns
 - iii. Depressions
 - b. Lengthwise Measurement
 - i. Lengthwise Tilt
3. There shall be no crosswise tilt in excess of the 40/1000 inch over the width of the lane.
4. The same lane finish coating shall be applied from edge board to edge board.
5. The coefficient of friction of all lane surfaces shall not exceed 0.29 when measured with a USBC approved device.
 - a. All bowling lane finish coatings as well as all synthetic lane surfaces must be submitted to USBC for coefficient of friction testing before use in certified competition.
6. All lane surface coatings must bear labels stating "This product complies with USBC specifications when applied as directed by the manufacturer."

USBC Regulation Bowling Lane Dimensions

Typical Cross Section of Bowling Lane — Round Gutters from foul line to pin deck area.

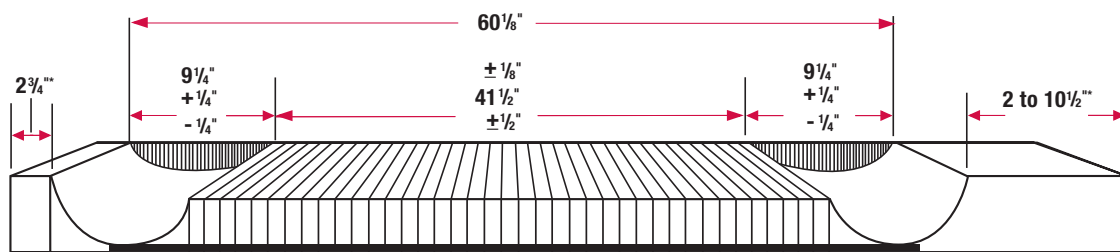

NOTE: This particular measurement is not a USBC specification but is an accepted standard for installing bowling lanes.

Figure 29

Lane and Approach Markings or Designs

Lane and approach markings shall only be permitted in accordance with the following specifications:

1. Measured from the foul line, a maximum of seven guides may be embedded in or stamped on the approach at each of the following points: 2-6 inches; 3-4 feet; 6-7 feet; 9-10 feet; 11-12 feet; and 14-15 feet. Each series of guides shall be parallel to the foul line and each guide shall be circular in shape and shall not exceed $\frac{3}{4}$ inch in diameter.
2. At a point 6-8 feet beyond the foul line and parallel thereto, there may be embedded in or stamped on the lane a maximum of 10 guides. Each guide shall be uniform, circular in shape, and shall not exceed $\frac{3}{4}$ inch in diameter.
3. At a point 12-16 feet beyond the foul line, there may be embedded in or stamped on the lane a maximum of seven targets. Each of the targets shall be uniform and may consist of one or more dowels, darts, diamond, triangles, or rectangular designs. The overall surface covered by each target shall not be more than $1\frac{1}{4}$ inches in width and six inches in length. Each target must be equidistant from one another and set in a uniform pattern.
4. At a point 33-44 feet beyond the foul line, there may be a maximum of four targets. Each target must be uniform in appearance and shall not be wider than a single board or longer than 36 inches.
5. Embedded markings or designs shall be of wood, fiber or plastic and shall be flush and level with the surface of the lanes and approaches.

6. When the markings are stamped on wood lanes, they shall be applied to the bare wood and then covered with lacquer, urethane, or similar liquid transparent material generally used in resurfacing. All such installations in any one center shall be uniform as to design and measurements and at least on natural pairs of lanes.
7. Glow/Cosmic bowling may only be certified on lanes that meet all of the specifications listed under **Lane and Approach Markings or Designs**.
8. Glow/Cosmic lane designs must only be visible in glow conditions.
9. In an area within two inches, but not closer than one-half inch of the foul line, there may be an advisory about crossing the foul line. The wording/lettering/symbols of the advisory may be 1 to 1½ inches tall. The advisory shall run parallel to, and shall not extend more than two inches from the edge of the foul line. The advisory must be first submitted to the USBC Specifications Department for prior approval.
10. For certification process, a center shall have each lane numerically numbered and not duplicated. The number may or may not be visible to the general public but must be easily seen by the inspector, e.g. on the back side of the masking unit.

Designs and Logos

Special Events

Some special events (such as PBA events, televised events, etc.) may be allowed to imprint or display (physically or virtually) designs or logos on the playing area (lane, approach, etc.) while still maintaining USBC certified status. This requires prior written consent from USBC. All other lane specifications must be met in accordance with this manual (e.g. no decals above the surface of the lane, etc.). Contact the USBC Equipment Specifications and Certification Department for an application sheet, association fees, and more information.

Non-commercial Centers (Universities, Fraternal, Military, and Other)

Non-commercial bowling centers may be allowed to imprint or display (physically or virtually) designs or logos, such as school mascots or crests, within the approved area on the approach while still maintaining USBC certified status. (See Figure 30)



Figure 30

The approved logo area is defined as the approach area between the first and second sets of dots from the back of the approach, with a 6" buffer on each side.

Note: See page 24 for definitions of acceptable locations of approach markings or dots. (See Figure 31.)

Bowling Lane with Safe Area for logo

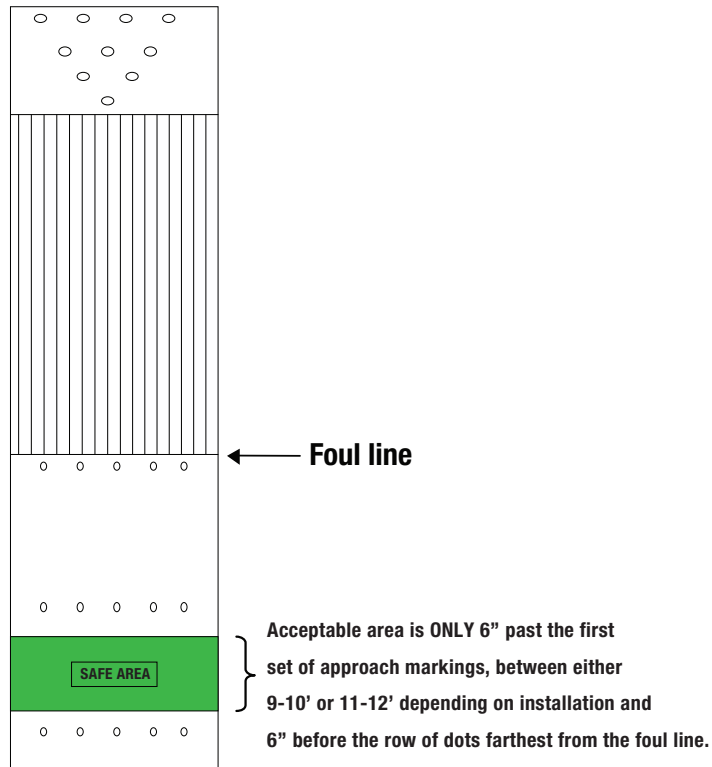

Figure 31

The logo must not cover any of the approach markings. The logo itself must be placed within or under the top surface so as to not have a different texture or feel. This requires prior written consent from USBC. All other lane specifications must be met in accordance with this manual (e.g. no decals above the surface of the lane, etc.).

Synthetic Bowling Lane

All synthetic bowling lanes must be USBC approved and meet all specifications for regulation bowling lanes in addition to the following:

Identification

On synthetic lane surfaces, each panel must have at least one label that meets all of the following requirements:

1. The label, identifying the manufacturer, must be permanent, lasting the life of the product and clearly visible after it is installed.
2. The label must contain an approval number assigned by USBC and state "USBC Approved."
3. The color of the label can be similar to the colors used in the pattern as long as they are

visible upon inspection.

4. The label must be located on the lane per manufacturer's agreement with USBC.
5. The size of the label shall be limited to the width of the board (approximately 1 1/16 inches) and shall not exceed 2 inches in length.

USBC approval is based on specifications and sample material provided at the time of application and the foregoing conditions. Any modifications or anticipated change in construction, materials, and/or installation procedures must be reported to USBC to ensure continued approval under these terms.

Gaps and Drop Off

On synthetic lane surfaces, either panelized or overlay, where two panels meet, the following specifications must be met:

1. The leading edge of one panel shall be flush with, or not more than 40/1000 inch below the trailing edge of the adjoining panel at any point across the width of the lane.
2. The leading edge of the first panel shall be flush with, or not more than 80/1000 inch below the trailing edge of the foul line at any point across the width of the lane.
3. The gap between the leading and trailing edge of adjoining panels, across the width of the lane, shall not exceed 50/1000 inch at the time of installation.

(See Figure 32)

Surface

The surface of a synthetic lane may not be altered (coated) with any material unless first tested and approved. All new synthetic surfaces submitted to USBC for testing/approval must meet a minimum SWARD Hardness of 35. All samples not meeting a "minimum average" of 45 with require an additional sample(s). The SWARD Hardness method of testing may be found in the Procedures Manual.

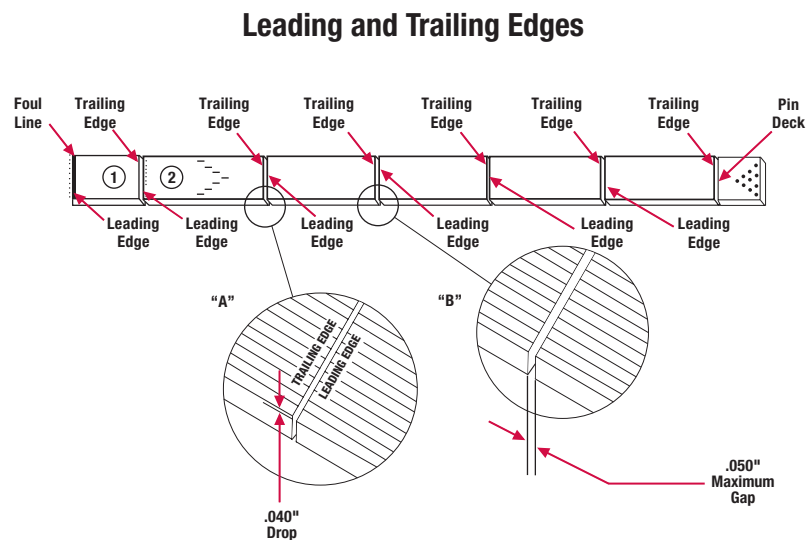

Figure 32

Pin Deck Area

Composition

The pin deck may be constructed entirely of hardwood. Synthetic materials, alone or in combination with other materials, may be used provided these materials have been tested and approved by USBC.

Edge Boards

The edge boards must be rounded on a radius of not more than $5/32$ inch. If the radius is removed, such radius must be restored. The edge board may be constructed entirely of hardwood without testing. Synthetic materials, alone or in combination with other materials, may be used provided these materials have been tested and approved by USBC.

Edge Strip Specifications

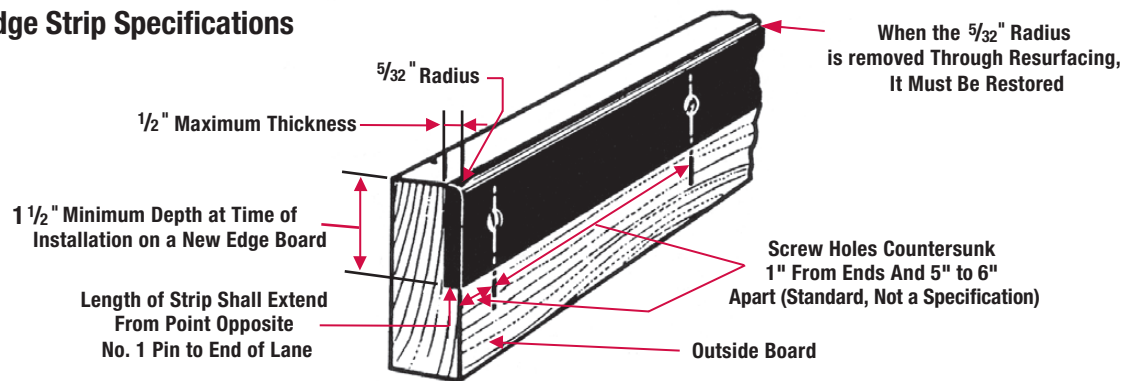

Figure 33

Synthetic Edge Strip

A synthetic edge strip, measuring not more than $1/2$ inch in thickness and:

1. not less than $1 1/2$ inches in depth, at time of installation on a new edge board
2. not less than one inch in depth, at time of installation on an existing edge board

A synthetic edge strip may be attached to the side of the pin deck nearest the gutters and at a minimum, shall extend from a point opposite the No. 1 pin to the pit. It must be installed vertically so the synthetic material exposed on the pin deck surface is not in excess of $1/2$ inch.

Synthetic Pin Decks

If the pin deck surface includes the tail plank, the end of the lane must be visibly identified with a minimum mark of at least two inches in length on the 10-pin side of the pin deck for the life of the pin deck.

If nonwood pin decks are in use with either wood or nonwood lane surfaces, the leading edge of the pin deck must be flush to, with not more than $40/1000$ inch below, the trailing edge of the adjoining lane section across the width of the lane.

The gap between the pin deck and the adjoining lane section, across the width of the lane, shall not exceed $50/1000$ inch at time of installation.

Pin Spots

There must be 10 visible pin spots on the pin deck that meet all specifications.

All pin spots, upon which the pins must be set, shall be clearly identified for the life of the pin deck and be $2\frac{1}{4}$ inches in diameter, plus/minus $\frac{1}{16}$ inch, and meet the following location specifications:

1. Spaced 12 inches, plus/minus $\frac{1}{16}$ inch, (non accumulative) in an equilateral triangle.
2. 3 inches, plus/minus $\frac{1}{16}$ inch, from the center of 7, 8, 9 and 10 pin spots to the pit (not including the tail plank).
3. $2\frac{3}{4}$ inches, plus/minus $\frac{1}{4}$ inch, from the center of the 7 and 10 pin spots to the adjacent side of the pin deck.
4. $12\frac{1}{16}$ inches, plus/minus $\frac{1}{16}$ inch, from the center of the 7 and 10 pin spots to the nearest kickback.
5. The No. 1 pin spot shall be equidistant from both edges of the lane kickbacks with a tolerance of plus/minus $\frac{1}{8}$ inch, and never less than 30 inches from its center to the kickbacks.
6. $31\frac{3}{16}$ inches, (reference dimension) from center of the No. 1 pin spot to a perpendicular line drawn through the centers of the back row of spots.
7. $34\frac{3}{16}$ inches from the center of the No. 1 pin spot, to the pit (not including the tail plank).

Pin Spots on Pin Deck

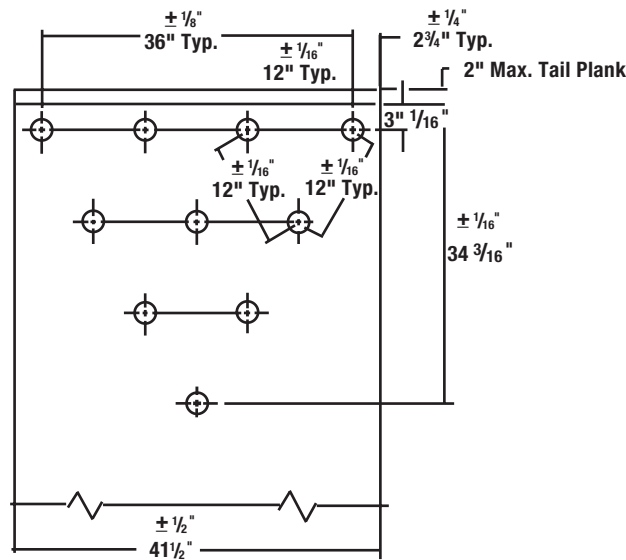

Figure 34

Tail Plank

A tail plank, not to exceed two inches in thickness, may be attached to the rear of the lane. The tail plank may be constructed entirely of hardwood without testing but synthetic materials, alone or in combination with other materials, must be approved by USBC before use.

The exposed edge of the tail plank may be covered with a piece of synthetic material which must have a radius of 5/8 inch, plus/minus 1/8 inch at the intersection of the top edge and rear face of the tail plank. At no time may there be more than five inches of flat playing surface, including the tail plank, in back of the centers of 7, 8, 9, and 10 pin spots.

Reinforced Tail Plank

Optional Methods

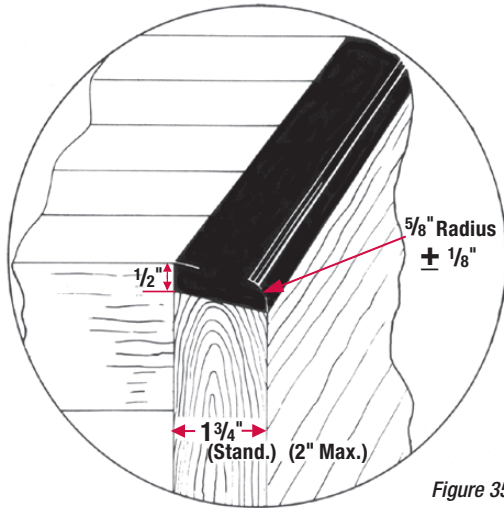

Figure 35

Fibre or Phenolic Applied on Slanting Joint

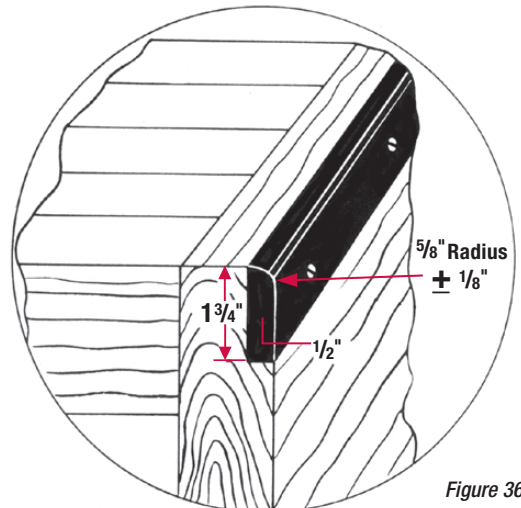

Figure 36

Fibre or Phenolic Applied on Right Angle Joint

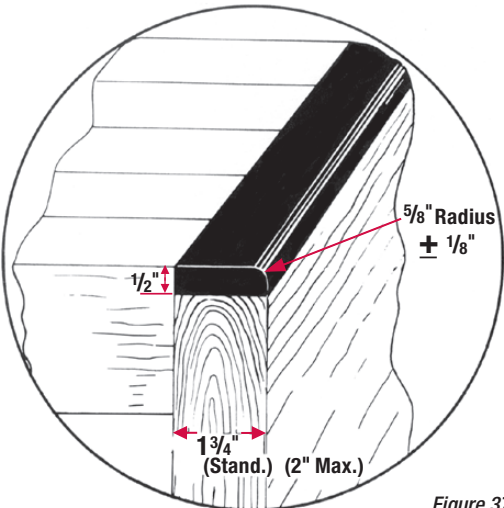

Figure 37

Fibre or Phenolic Applied on Exposed Edge

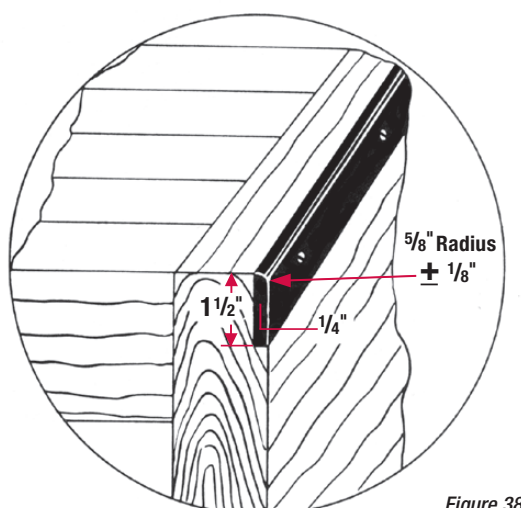

Figure 38

Fibre or Phenolic Applied on Right Angle Joint

Other Pit Area Specifications

Gutters shall be placed on each side of the lane and shall begin at the foul line and extend parallel with the lane to the pit.

Round Gutters

1. The width shall be 9¼ inch, plus/minus ¼ inch.
2. They must be concave in shape.
3. They must measure at least 1 7/8 inch in depth at the center at time of manufacture.

Flat Gutters

Flat gutters must be constructed of wood or other materials which have been tested and approved according to USBC procedures for the specified time period.

1. The width shall be 9¼ inches, plus/minus ¼ inch, including the molding.
2. From a point opposite or within 15 inches ahead of the No. 1 pin spot, the gutter must have square bottoms and must be at least 1 7/8 inch beneath the surface of the lane.
3. Opposite the center of the rear row of pin spots, the depth shall be 3½ inches, plus/minus 1/8 inch.

Reinforced Flat Gutters

1. The dimensions shall be the same as flat gutters.
2. The reinforcing material may cover the entire length and width of the bottom, or be four inches, plus/minus ½ inch, in width and cover the total length.
3. If vulcanized fiber reinforcing is used, it shall not exceed 3/16 inches in thickness.
4. If laminated phenolic reinforcing, Grade "C" or "CE" is used, it shall not exceed 1/8 inch in thickness.

See Figures 39-42.

Flat Gutter Molding (Solid Hardwood)

A strip of molding extending the entire length of the flat gutter shall be securely fastened to the bottom of the flat gutter. The molding may be constructed entirely of hardwood without testing. Synthetic materials, alone or in combination with other materials which have been approved by USBC after testing, may be used.

1. They may not exceed 7/8 inch high, at the leading edge, gradually increasing to a maximum of 1½ inches high opposite the 7 and 10 pin spots. (Measured from the top surface of the flat gutter to the top of the molding.)
2. They may not exceed ¾-inch in width.
3. The top exposed edge shall be rounded to a radius of 5/8 inch, plus/minus 1/8 inch.

Reinforced Flat Gutter

Optional Methods

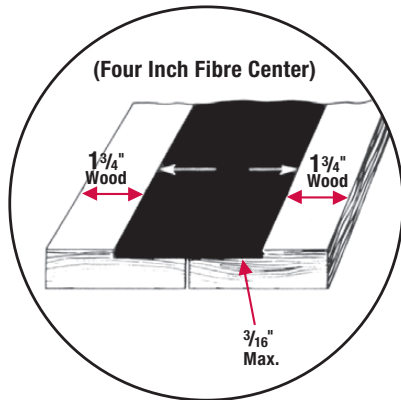

Figure 39

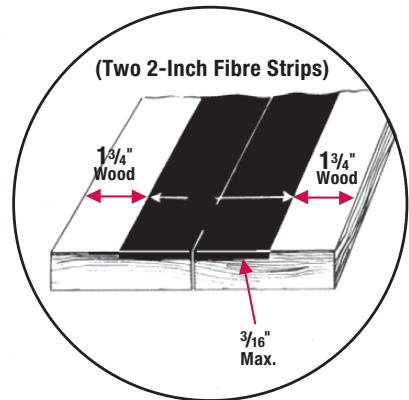

Figure 40

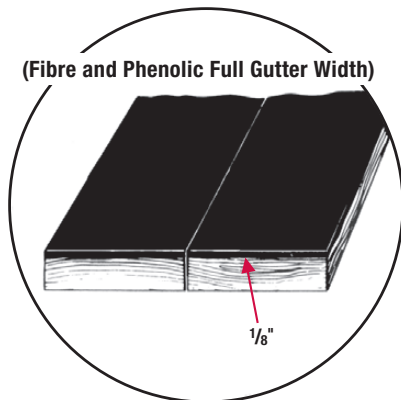

Figure 41

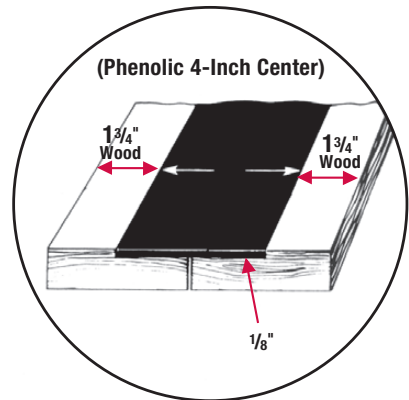

Figure 42

Reinforced Flat Gutter Molding

1. They must meet all physical dimensions of solid hardwood flat gutter molding.
2. The wearing surface may be reinforced from the pit to at least the point opposite the No. 1 pin spot.
3. If vulcanized fiber is used, it may not exceed $\frac{1}{4}$ inch when used on the side or $\frac{1}{2}$ inch thick when used on the top. (See drawings – figures 43-46)
4. If laminated phenolic material Grade "C" or "CE" is used, it shall be $\frac{1}{8}$ inch thick. See Figures 43-46.

Kickbacks

The kickback may be constructed entirely of hardwood without testing. Synthetic materials, alone or in combination with other materials which have been approved by USBC after testing, may be used. The kickbacks, or side partitions, shall be placed parallel to the lane and shall meet the following requirements:

1. It shall extend from a point opposite or within 15 inches ahead of the No. 1 pin spot to the rear cushion wall.
2. The distance between the wood faces of the two kickbacks shall be 60 1/8 inches, plus/minus 1/8 inch.
3. The height above the lane shall be 20½ inches, plus/minus 3½ inches.

The kickbacks, behind the tail plank, may be covered with impregnated fiber glass, hard vulcanized fiber, or laminated phenolic (Grade "C" or "CE").

Kickback Plates

The kickbacks may be covered with a single layer of reinforcing material, not to exceed 3/16 inch in thickness. The following materials may be used:

1. Hard vulcanized fiber.
2. Laminated phenolic (Grade "C" or "CE").
3. Rigid thermoplastic vinyl copolymer.

Other materials may be used provided they have been tested and approved by USBC.

Rear Cushion

The rear cushion shall in all cases be covered with material of a dark color and shall be so constructed as to prevent the pins from rebounding onto the lane. (For pit and rear cushion measurements on automatic pinsetting devices, see section on Automatic Pinsetting devices in this manual.)

Reinforced Flat Gutter Molding

Optional Methods

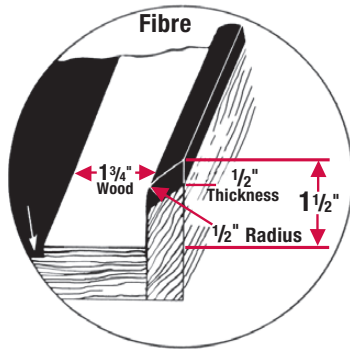

Figure 43

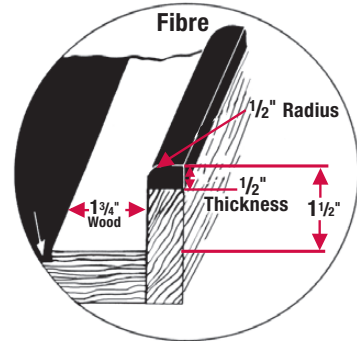

Figure 44

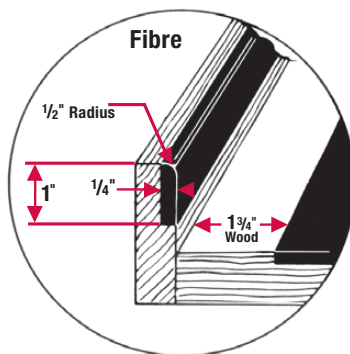

Figure 45

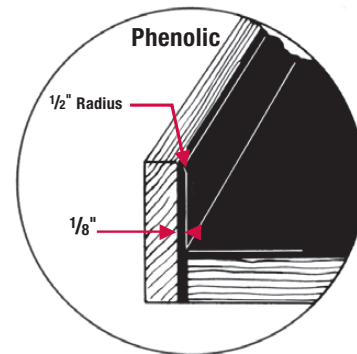
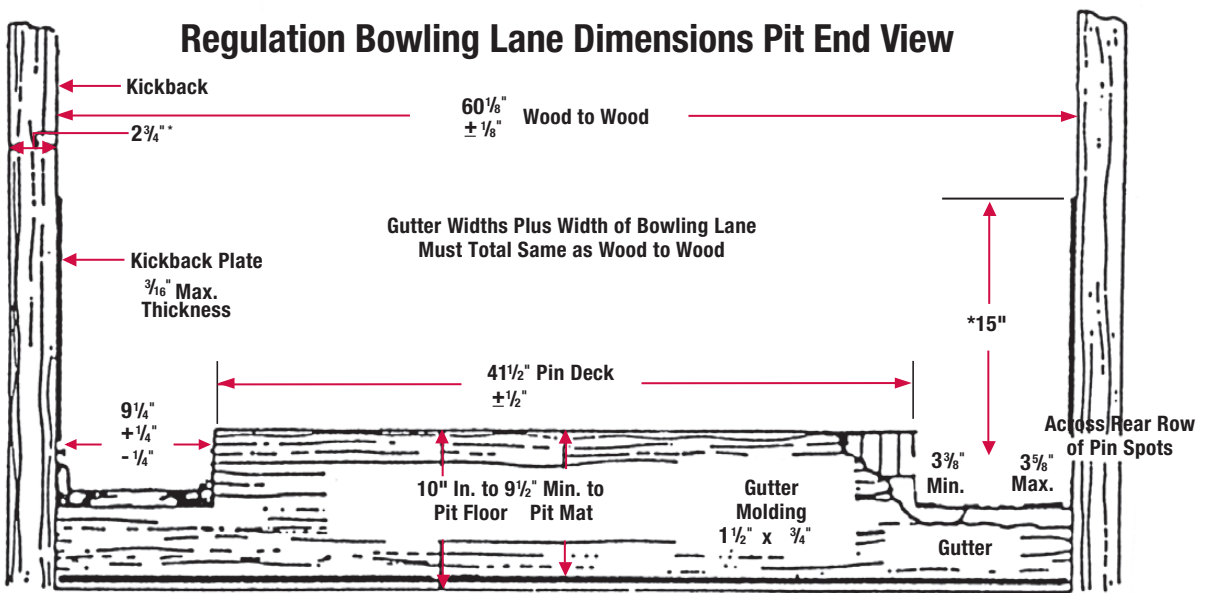

Figure 46

Pit

1. For lanes without automatic pinsetting devices, there shall not be less than 10 inches from the pit floor to the top of the lane and it shall not be less than 9 1/2 inches from the top of the pit mat to the top of the lane. The pit shall not be less than 30 inches in depth from the rear edge of the lane (including the width of the tail plank as a portion of the measurement) to the face of the rear cushion.
2. For lanes with automatic pinsetting devices, see the section on Automatic Pinsetting Devices.



* Note: These are not specifications but accepted standards for installing bowling lanes.

Figure 47

Regulation Bowling Lane Dimensions Side View – Pit End

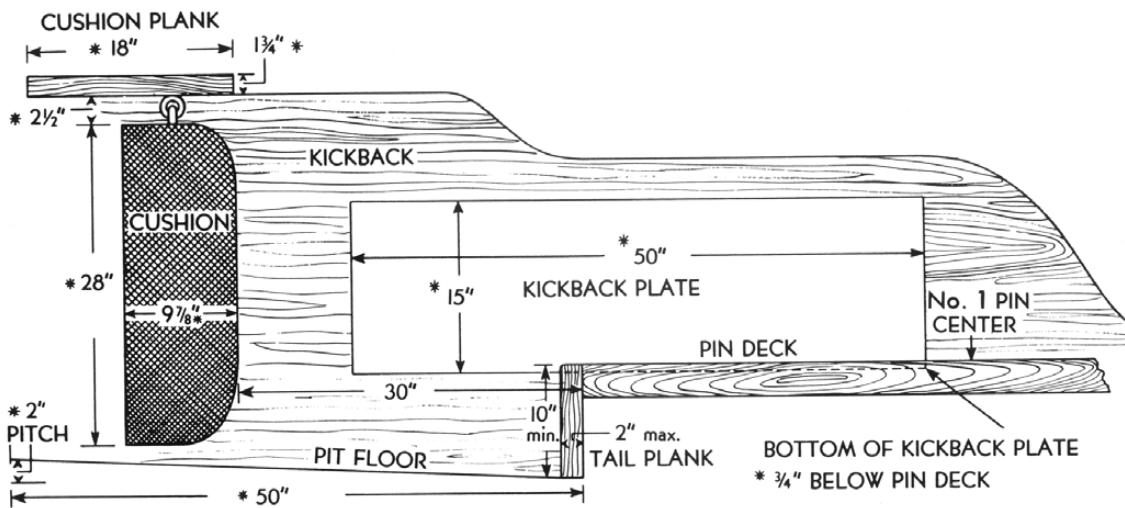

Figure 48

Technical Specifications for Fully-Automatic Pinsetting Devices

All automatic pinsetting devices must be USBC approved and meet the following specifications:

1. Be designed to operate under all situations normally arising in a certified league or tournament.
2. Be constructed so it can be installed on any USBC regulation lane except where approval has been obtained to modify or alter one or more of the specifications in the pit area.
3. Such device must perform entirely automatic. A push button may be installed to operate the device in the event of certain emergencies. Such push button to be installed where it is easily accessible to the bowler or scorer. An emergency shall be considered if and when the machine is unable to pick up a pin which has moved more than $1\frac{3}{4}$ inches off the pin spot (measured from center of spot to center of moved pin); or when pins are left standing at the conclusion of the third delivery in the 10th frame plus an occasional machine malfunction.
4. It must conform with all provisions of USBC rules and regulations pertaining to pinfall. The device must be able to return any pin to the same position to which it has been moved by a previous delivery, except when an emergency shall have been considered, as described in requirement three.
5. The machine must be able to operate under permissible voltage fluctuations existing in the community where it is installed and in use.
6. The completed installation must comply with the requirements of the state or local inspection authorities.
7. There shall be a minimum of three seconds between the time the ball reaches the pit and activates the cushion or back stop and the pin table descends and contacts the standing pins.
8. The pit floor at the tail plank shall measure not less than $4\frac{3}{4}$ inches below the pin deck surface.
9. The minimum distance from the end of the lane to the nearest point of the cushion shall be 25 inches. The measurement includes the width of the tail plank.
10. Each automatic pinsetting device shall be equipped with a curtain or other pin-arresting device. The curtain and the cushion shall be so located and constructed that no pins may rebound from the curtain or cushion onto the pin deck. (See Figures 49-54, page 36)
11. Each automatic pinsetting device shall, on the first ball cycle, place the bowling pin completely on the pinspot of the pindeck.
12. In establishments using pinsetting devices, such devices must be checked annually, by the local association manager or authorized representative, at the time lanes are being checked for certification to determine if pins are spotted correctly.

Pit Measurements — Automatic Pinsetting Device

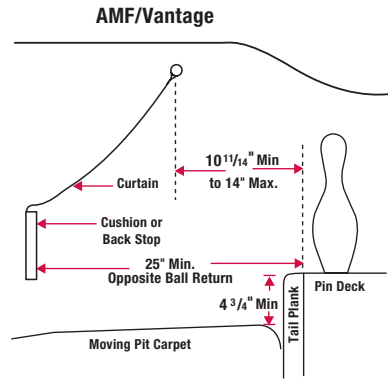

Figure 49

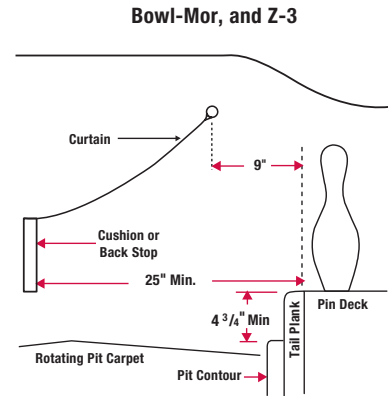

Figure 50

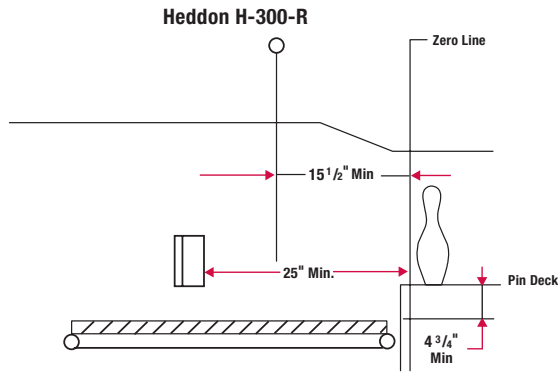

Figure 51

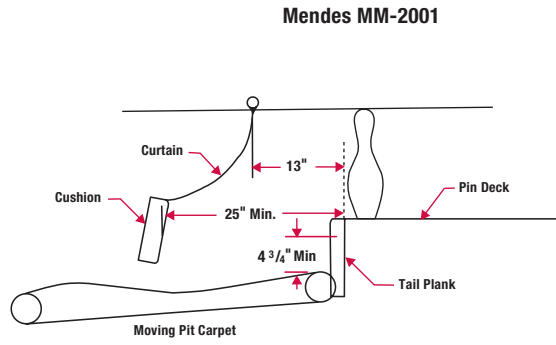

Figure 52

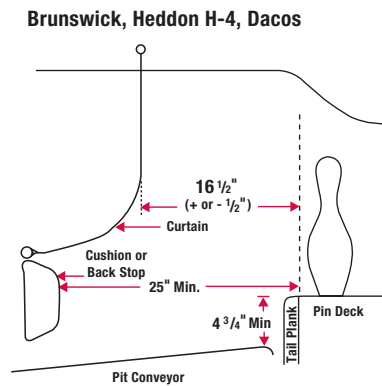

Figure 53

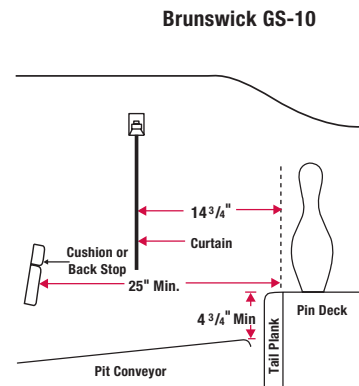

Figure 54

Technical Specifications for Automatic Scoring Device

An automatic scoring device which meets the following specifications and has been approved by USBC may be used in certified competition.

1. This device must record scores in accordance with USBC General Playing Rules.
2. Any such device attached to approved equipment for automatically setting pins shall not affect their operational aspects to the point of altering scoreability.
3. Such device must detect and score off-spot pins so they will not be improperly registered as pins knocked down. An off-spot pin shall be defined as a pin that has moved, but one that an approved pinsetting device is still able to pick up and respot.
4. A means of manual correction must be provided which is easily accessible to the bowler or scorer to allow for correction of a score for incidents such as bowling out of turn, illegal or improper pinfall, provisional balls, late starts, dead balls, blinds, handicaps, out-of-range pins (a pin which has moved and cannot be picked up by an approved pinsetting device), malfunction of the device, etc.
5. The device must accommodate the existing pattern of bowling where the bowlers and/or team bowl on a pair of lanes, alternating after each frame.
6. The device must provide a printed record which can be audited frame by frame. This shall include the exact pinfall on each delivery.
7. Safeguards must be provided which prohibit the inadvertent loss of scores from the device by human error or other equipment failure.
8. An automatic foul detector may be incorporated into the Automatic Scoring device if so desired.
9. Each scoring device is to be individually presented to the USBC Equipment Specifications Department for evaluation.

Technical Specifications for Automatic Foul Detecting Device

Each certified bowling center must have an approved automatic foul detecting device or provision to station a judge at the foul lines during USBC certified competition. If an automatic foul detecting device is used, it must be USBC approved and meet the following specifications:

1. The foul detecting device must be entirely automatic. No manually operated push buttons, switches, levers, or other devices will be accepted.
2. Any equipment necessary to the operation of an automatic foul detection device must be flush with the division board if mounted therein.
3. The automatic foul detecting device must be able to operate under permissible voltage fluctuations existing in the community where the device is installed and in use.

4. The automatic foul detecting device must be equipped with a visible signal. Such light signal shall be visible to the scorekeeper and bowler and shall remain visible for not more than 15 seconds or less than 10 seconds. It is also recommended that a sound signal be provided. Such signal should be of sufficient intensity to be heard at the bowler settee area.
5. The beam of the foul detecting device shall not be set more than $\frac{1}{4}$ inch beyond the approach side of the foul line.
6. The completed installation must comply with the requirements of the state or local inspection authorities.

Lane Certification/Inspection

A. Application/Inspection

1. When a bowling center requests certification, the association manager shall ensure an inspection is done. The lanes and equipment would be measured and inspected for compliance with physical specifications. In addition, USBC may authorize military personnel to perform annual inspections of bowling centers located within the boundaries of overseas U.S. military installations.
2. When completed, all required inspection information, together with an application for a bowling center certificate signed by the bowling center's authorized representative, shall be sent to USBC Headquarters.
3. Inspections may be made as early as April 1 prior to the start of the season and no later than August 31 after the start of the season for which the certificate is to apply. In addition, inspections cannot be made prior to any resurfacing or alteration of the lanes scheduled to be completed by August 31 of that season.
4. Certificates issued shall expire on August 31 following the season for which issued, unless a noncertified center requests certification and is inspected after December 15 or a certified center resurfaces and is inspected after December 15. When certificates are issued for such centers, they may be renewed effective August 1 of the next season without further inspection.
5. The fees payable to USBC shall be \$3 for the first four lanes, plus 50 cents for each additional lane for initial certifications of a new bowling center. Any request for certification following non-issuance for the prior season, or withdrawal, will be considered an initial certification.
6. The fees payable to local associations for measurement and inspection shall not exceed \$5 for each lane, which includes two additional inspections, if necessary. For each additional visit needed to complete the certification process, the local association may charge a fee not to exceed \$20.

NOTE: Local associations collecting certification fees in other than U.S. currency shall charge the equivalent of U.S. funds for the amounts referred to in Items 5 and 6.

B. Issuance

On submission of an application, if it is determined that the terms of certification and all other requirements have been met, a certificate will be issued.

C. Representation

A certificate issued to a bowling center shall be displayed in the center. By doing so, the owner and all operational personnel represent that its best effort will be given to ensure that all bowling equipment, lane dressing and its distribution meets and continues to meet all requirements for certified competition.

D. Retention

In addition to compliance with all other terms and conditions of the certification requirements, retention of a certificate shall be subject to the following:

1. If dressing is used, it shall meet specifications and must comply with the following:
 - a. Dressing must be distributed from edge board to edge board for the entire distance that dressing is applied. (In the application of this rule, buffing the lane is considered applying dressing.)
 - b. Following any application of dressing, in the dressed portion of the lane there shall be a minimum of three units of dressing at all points on the lane surface.
 - c. Any stripping (cleaning) of dressing from the lanes must be uniform from edge board to edge board and at least from the headpin to the distance to which dressing has been applied.
2. The lane surfaces shall not be altered or conditioned to create a ball path or otherwise affect the course of the ball or pinfall by use of abrasives, dressings or any other materials or methods. (For example, and without intending any limitation of the rule, the resurfaces, owner, manager and maintenance personnel are specifically prohibited from creating grooves or tracks in the lane to form a continuous ball path even through within allowable tolerances.)
3. Any adjustment or modification of lane maintenance equipment to create the conditions described in Item 2 above is specifically prohibited.
4. Any local association representative designated by the association manager, as well as any authorized representative of USBC, shall be permitted at any time to inspect a certified center for compliance with bowling equipment specifications and lane dressing requirements, and to inspect all equipment the center uses to maintain its lanes.

NOTE: *Although there is a minimum requirement, additional inspections can be performed at the discretion of the local association. Should an inspection note noncompliance, additional inspections should be performed until compliance is met.*

NOTE: *Inspection information obtained shall be recorded on report form(s) provided by USBC.*

- a. A minimum of one complying inspection per season shall be required from each center.
- b. A copy of the inspection report(s) shall be submitted to center management and USBC Headquarters within 10 days.
- c. References to inspections in this item shall mean unannounced inspections of randomly selected lanes, including measurement of lane dressing applied before bowling

Failure to comply with any of the foregoing shall constitute grounds for score denials and suspension or withholding of membership of all persons involved, including owners, managers and maintenance personnel, and shall also constitute grounds for the action set forth in the noncompliance procedures of this chapter.

E. Penalty for Noncompliance

Anyone who attempts or directs another to alter lanes to create a ball path or otherwise affect the course of the ball or pinfall, or permits any of the foregoing to occur, is liable for suspension of membership. A nonmember found to have taken or permitted such actions may be denied membership until his/her application is approved by USBC Headquarters.

F. Noncompliance Procedures

The following procedure will apply when lane dressing, surface requirements or bowling equipment specifications are noncompliant:

1. The local association and the bowling center will be notified of the decision and its right to appeal.
 - a. If there is no appeal, the decision will be final.
 - b. If there is an appeal, it will be case handled by USBC Headquarters.
 - c. If there is a certificate withdrawal, the bowling center and each league/tournament will be notified that following completion of the current schedule, any future leagues/tournaments will not be certified until the certificate has been reinstated.

NOTE: *References to bowling center notices in this section shall mean notice to the owner and/or any other representative designated by the owner. References to leagues/tournaments shall mean those bowling or scheduled to bowl in the center which have applied for certification or are certified.*

G. Miscellaneous

1. In the event a certificate is temporarily suspended or withdrawn, any bowler who withdraws from a league in the bowling center shall be deemed to have done so for satisfactory reason for the purposes of Rule 114a.
2. None of the provisions of the certification requirements shall be interpreted to limit any action that may be taken when it is deemed necessary to protect the integrity of bowling. In such cases, USBC may conduct a hearing in the matter. The Board of Directors may authorize issuance of membership to members of leagues desiring to be certified and committed to bowl in a bowling center in which a bowling center certificate is not in effect. All members of such leagues must apply for membership.
3. Privileges and services will be provided to members of such leagues, but shall not include recognition of averages, all pins-over-average awards, all national recognition awards, 11-in-a-row, 300 games and 700 and 800 series or better. Such privileges and services may not be extended for more than one season, or longer than one year.

Lane Dressings and Lane Dressing Measuring Equipment

Technical Specifications for Lane Dressing

Only lane dressings containing a USBC approved additive added by the dressing manufacturer, and meeting the following requirements, shall be acceptable for use on lanes where certified competition is conducted:

1. The specification for UV content shall be 300-367 ppm by weight.
2. The dressing-additive mixture shall be so homogenized as to assure a storage life of not less than six months without noticeable separation of the additive.
3. The dressing-additive mixture shall comply with safety standards and shall not be harmful to health.
4. All dressing containers shall bear the USBC approved logo.
5. A one-liter sample of oil shall be supplied to USBC upon request for evaluation of UV additive content and homogenous characteristics. The purpose of the additive is to provide a bowling surface condition enabling accurate measurement and recording of the relative amount of dressing across the width of the lane. There shall be no deviation from an approved additive/dressing without prior written approval from the USBC.
6. All lane conditions must have a viscosity between 12 cP (centipoises) and 81 cP @ 21.1° C (70° F) when using a Brookfield LVDV +II Pro Viscometer equipped with an LV1 spindle using the guard leg at all times in order to maintain the % torque at the recommended value in the 10-100 range while set at 60 RPM.
7. All lane conditioner manufacturers are required to include in the Regulatory Section of their product's MSDS that the lane conditioner meets all United States Federal Government CFR (Code of Federal Regulations) Title 21 requirements for GRAS (Generally Regarded as Safe) relating to product human contact and possible human ingestion. For more information on these statutes, please contact USBC Equipment Specifications Department or consult CFR title 21.

Technical Specifications for Lane Dressing Tape Take-Up Device

These specifications establish the requirements for the lane dressing take-up device to be employed to apply the tape described in USBC specifications for lane dressing pick-up tapes to, and remove it from, the surface of a bowling lane.

1. By mechanical action, the device shall apply one layer of tape to and across the width of a lane, with the adhesive side on the lane surface. A second mechanical action shall pick up the original tape and simultaneously affix a second like tape to the first tape, adhesive sides together, so as to encapsulate the lane dressing picked up by the first tape between the two layers of tape.
2. The device shall accept two rolls of the tape on separate spools. The free ends of the tapes, affixed together, shall be held firmly in place while the tape from one spool is applied to and rolled across the lane by means of a flexible wheel, guided by a channel provided by the device running across the width of the lane. Then, as the first tape is removed from the lane surface and picked up by the device, the second tape shall be dispensed from its spool and affixed, adhesive sides together, to the first tape. The combined sample can then be removed from the device.
3. The part of the device holding the free end of the tapes during dispensing shall have a holding force of not less than five pounds to assure that the tapes will not pull free while being applied and picked up.
4. The device shall be capable of superimposing the second tape on the first with no more than 1/16 inch misalignment.

5. The device shall be capable of performing 10,000 operations as specified without failure or excessive wear. Lubrication, if required, at 100-hour usage intervals, shall suffice to assure effective operation of the device.
6. The device shall be capable of being cleaned by wiping with a cloth.
7. The device shall be designed and manufactured to “best commercial practice” and shall be operational without damage after being subject to the following tests:
 - a. Vibration: 0.01” displacement, 1 Hertz per second to 400 Hertz per second applied to any of four sides. At least two vibration tests, each of one minute duration, must be satisfactorily met.
 - b. Shock: 4 Gs when applied to any of six sides.
8. Unless otherwise specified by USBC, all examinations and tests shall be made at the following environmental conditions:
 - a. Operating: +30 to +100 degrees Fahrenheit
 - b. Storage: -30 to +165 degrees Fahrenheit

Only a device approved by USBC as meeting these requirements shall be employed for application of the tape on lanes where certified competition is conducted.

The manufacturer of an approved device shall be responsible for continuing compliance with these requirements and USBC reserves the right to perform any inspection and/or test which it deems appropriate to assure that the device does comply.

To that end, unless waived by USBC, the manufacturer shall supply one device out of each 500 units manufactured for visual and mechanical inspection by USBC, at the manufacturer’s site or as directed by USBC. Such device may be selected at random by USBC from the production line. At USBC’s discretion, the device may be subject to the environmental extremes and/or vibration and/or shock requirements of these specifications. Failure of the device to pass all requirements of these specifications shall constitute a basis for withdrawal of approval.

The manufacturer may recommend improved design changes. However, once approval has been given by USBC, no modification may be made to the device without prior written USBC approval.

Lane Dressings and Lane Dressing Measuring Equipment

Technical Specifications for Ultraviolet-Sensitive Tape Reader

These specifications establish the requirements for an instrument (the reader) capable of measuring the amount of ultraviolet-sensitive additive in lane dressing which has been encapsulated as described in USBC specifications for lane dressing pick-up tape.

1. The reader shall accept a one-inch wide, two-layer tape which has encapsulated the lane dressing and shall provide reading of the ultraviolet-sensitive additive in the lane dressing within the accuracies herein specified.
2. The ultraviolet sensing device within the reader shall be sensitive to 435 nanometer light and shall operate in the linear portion of the curve to provide a linear output of the read-out over its projected range. Detection shall be linear from 0.005 to 5 cc of percent nonvolatile material per square foot with a concentration of 0.033 percent ultraviolet tracer in the dressing. The reader’s sensitivity shall be capable of differentiating between 0.00835 cc per square foot.
3. The output reading shall be displayed to provide a comparison of the relative amount of

- additive encapsulated along the length of the tape.
4. The reader shall include a drive tape advancement mechanism that shall advance the tape in 1 1/16 inch increments with cumulative error of not more than 0.5 inch in 42 inches. The manual mechanism shall have detents at 1 1/16 inch increments.
 5. The tape path shall be constructed to minimize any sideward tape movement, while permitting hand feed of the tape until engaged by the drive mechanism, at which time the drive will advance the tape as specified in Item 4.
 6. The tape path shall be readily cleaned and constructed to prevent an accumulation of fluorescent debris.
 7. Stray light shall not present interference in a brightly lit room or in direct sunlight.
 8. The control for driving the tape shall be easily accessible to the operator and the reader shall otherwise be constructed to assure operator convenience, including the position of switches, lamps, controls, and overall size of the reader.
 9. The light source shall be a 375 nanometer ultraviolet light.
 - a. On the front panel, an indicator will show the primary power is on and another shall indicate when the ultraviolet light is functioning.*
 10. With the unit at ambient temperature the stabilization time, from the time the unit is turned on until the unit can make accurate readings, shall be approximately 45 minutes. Verification shall be conducted by repeatable tests using the same tape and obtain readings produced previously plus/minus 2.
 - a. The readout indications for a test tape shall be repeatable after the unit has been operational for one hour without readjustment of the "null" control. Output shall be plus/minus 0.1 of the original reading.*
 - b. There shall be no noticeable change in the output reading when the AC input is varied between 105 and 125 VAC.
 11. The reader shall be capable of 500 hours operation with no adjustment of internal controls, during which time the output shall remain linear with no distortion over the required range of the reader.
 12. There shall be one external "null" adjustment allowing for setting the readout device to zero.*
 13. Unless otherwise specified by USBC, all examinations and tests shall be made at the following environmental conditions:
 - a. Operating: +30 to +100 degrees F
 - b. Storage: -30 to +165 degrees F
 - c. Relative humidity: 90 percent maximum; no minimum
 - d. Altitude: Sea level to 8,000 feet
 14. The units shall be designed and manufactured to "best commercial practice" and shall be operational, without internal adjustments, and shall have no mechanical failures (damage) after being subjected to the following tests:
 - a. Vibrations: 0.01" of displacement from, 1 to 400 Hertz/second when applied to any of six sides.
 - b. Shock: 2 Gs when applied to any of six sides.

**Applies to Original Black Box Reader.*

Only a USBC approved device meeting the foregoing requirements shall be employed for evaluation of sample tapes taken from lanes on which certified competition is conducted.

The manufacturer of an approved device shall be responsible for continuing compliance with the foregoing requirements and USBC reserves the right to perform any inspection and/or test which it deems appropriate to assure that the device does so comply.

To that end, unless waived by USBC, the manufacturer shall supply one device out of each 250 units manufactured for visual, electrical and mechanical inspection by USBC, at the manufacturer's site or as directed by USBC. Such device may be selected at random by USBC from the production line.

At USBC's discretion, the device may be subjected to the environmental extremes and/or vibration and/or shock requirements of these specifications. Failure of the device to pass all requirements of these specifications shall constitute a basis for withdrawal of approval.

The manufacturer may recommend improved design changes. However, once approval has been given by USBC no modification may be made to the device without prior written USBC approval.

Lane Dressings and Lane Dressing Measuring Equipment

Technical Specifications for Lane Dressing Pick-up Tape

These specifications establish the requirements for the lane dressing pick-up tape to be employed with the take-up device described in USBC specifications for lane dressing take-up device.

1. The tape shall be one-inch wide, substantially transparent when applied to a surface, having an adhesive side which, when rolled (with the take-up device) on and across a bowling lane, shall have the property of picking up all lane dressing from the lane surface. When a second like tape is affixed to the first tape, adhesive sides together, it shall effectively encapsulate the picked-up dressing. The combined tapes must permit comparative measurement of the ultraviolet-sensitive additive encapsulated along the tapes length by use of the reader device. (See specifications for ultraviolet-sensitive reader.)
2. The tape shall have a usable life of not less than 18 months, including at least six years subsequent to its application to a lane surface as described.
3. Unless otherwise specified by USBC, the tape shall perform as above after being subjected to the following environmental conditions:
 - a. Operating: +40 to +100 degrees F
 - b. Storage: -30 to +165 degrees F

Manufacturers Field Test Program for Products

This program is for the purpose of evaluating test products (excluding automatic scoring devices and automatic pin spotters) in the field for durability and scoring by the USBC. To conduct a manufacturer's field test, the following guidelines must be met:

1. Proposer shall notify the USBC Equipment Specifications Department not less than 30 days prior to the proposed installation date. The proposed location, with address, telephone number and a contact person at the center, date of installation, number of lanes and a full description of the test product must accompany the request.
2. USBC has the right to have their personnel present during the installation or at any time thereafter. The product must meet all USBC installation certification specifications

for the duration of the installation. USBC representatives will inspect the installation for verification of acceptable tolerances before allowing any certified competition to be conducted on the test product. They will inspect the installation at a minimum of every four months.

3. The proposer may have a maximum of 16 lanes per test. These test lanes may be divided between two bowling centers, but may include no more than half the lanes per center. Testing must be done on pairs of lanes (two lanes, four lanes, six lanes, etc.).
4. Each proposer may have a maximum of five field tests underway at one time. A field test may last a maximum of 1½ years before its termination or entering into an official USBC test. If the official USBC test is not started in that time period, the product must be removed or USBC certification will be withdrawn. If the official USBC test is started in that time period, the product can remain in use until the conclusion of the test and the USBC Equipment Specifications and Certification Committee's decision.
5. The Equipment Specifications Department has the right to refuse a field test if they feel the concept is inappropriate or compromises the integrity of the game. The proposer may provide supporting laboratory data as an appeal to the USBC Equipment Specifications and Certification Committee.
6. USBC can require the field test to be terminated at any time and have the test product removed from certified competition and an approved product reinstalled. All cost of the installation or removal of the test product will be the proposer's responsibility. Possible termination reasons could be, but are not limited to, product failure which could affect scoreability, product effects on scoreability compared to approved products, product creates a hazard to bowlers or bowlers' equipment, or at the request of the center ownership.
7. Before installation of the test product, a field test agreement must be completed in full and returned to the USBC Equipment Specifications Department.

Manufacturers Field Test Program for Pins

1. Only pins that have passed the threshold stage and official ramp scoring test may be eligible for a field test.
2. Proposer shall notify the USBC Equipment Specifications Department not less than 60 days prior to placing the pins into the field test. The proposed location, with address, telephone number and a contact person at the center, starting date and number of lanes and pins used, must accompany the request. A field test agreement form must be completed in full and returned to the USBC Equipment Specifications Department before starting the test.
3. ALL pins to be used in the field test must be submitted to the USBC Equipment Specifications Department not less than 60 days prior to the proposed start of the test. These pins will be tested by staff to ensure they meet all specifications and within the same parameters (i.e., scoring, center of gravity, weight) of those pins that passed the official ramp test. These pins must have permanent test pin labels when received by staff. Once tested and approved for the field test, staff will then permanent mark identification numbers on each pin.
4. Staff reserves the right to inspect the pins at any time during the test.
5. The test must be conducted in an area of the country acceptable to the USBC Equipment Specifications Department.
6. Length of test is limited to one year.

7. The USBC Equipment Specifications Department has the right to refuse a field test if they feel the concept is inappropriate or compromises the integrity of the game. The proposer may provide supporting data as an appeal to the USBC Equipment Specifications and Certification Committee.
8. USBC may terminate the field test at any time and have the pins removed from certified competition. All costs of placing the pins in play or removal of the test pins will be the proposer's responsibility. Possible reasons for termination could be, but are not limited to: pin failure, scoreability, poor pin performance in pinsetters, unacceptable to bowlers or at the request of the center ownership.



**621 Six Flags Drive
Arlington, TX 76011
800.514.2695**