

**SpaceX** is based on the philosophy that through simplicity, reliability and low cost can go hand-in-hand. By eliminating the traditional layers of management internally, and subcontractors externally, we reduce our costs while streamlining decisions and delivery. Likewise, by keeping the vast majority of manufacturing in-house we reduce our costs, keep tighter control of quality, and ensure a closed feedback loop between the engineering and manufacturing teams.

The Falcon launch vehicles have been designed to eliminate the main causes of launch vehicle failures – separation events and engines. Our vehicles have only two stages for minimum staging events and make use of either one engine per stage for simplicity or multiple engines for propulsion redundancy. To ensure manufacturing reliability and system performance, we have a full quality assurance program, an exhaustive acceptance test program, and a hold-before-launch system to prevent a liftoff with an underperforming first stage.

The Falcon launch vehicles are designed to serve a broad market that includes NASA and US Air Force missions with their stringent reliability requirements.

### **NASA's Choice To Resupply the Space Station**

In December 2008, NASA announced the selection of SpaceX's Falcon 9 launch vehicle and Dragon spacecraft to provide cargo resupply services to the International Space Station (ISS). The \$1.6 billion contract represents a minimum of 12 flights, with an option to order additional missions for a cumulative total contract value of up to \$3.1 billion.

NASA cited SpaceX's significant strengths as follows:

- First-stage engine-out capability
- Dual redundant avionics system
- Structural safety factor in excess of industry standards
- Enhanced schedule efficiencies
- Reduced overall technical risk to ISS cargo supply

### **Falcon Design Features That Enhance Reliability:**

- Two-stage design for minimum number of separation events
- Redundant stage and fairing separation systems
- Dual redundant avionics system
- Propulsion redundancy and simplicity
- First-stage engine-out capability on Falcon 9
- Simplest possible turbopump design – one shaft drives both LOX and RP-1
- Robust structure with high margins
- Hold-before-liftoff system
- Limited number of independent subsystems:
  - High-pressure kerosene tapped from turbopump to drive thrust vector control hydraulic system
  - Turbopump exhaust gas is used for roll control on Falcon 1

**SpaceX** has developed a family of launch vehicles and spacecraft that increase the reliability and reduce the cost of both manned and unmanned space transportation, ultimately by a factor of ten.

The performance of our Falcon line of launch vehicles, powered by SpaceX-developed Merlin engines, provides for light, medium and heavy lift capabilities to launch spacecraft into any altitude and inclination, from low Earth orbit to geosynchronous to planetary missions.

As the first rockets developed in the 21st century, the Falcon series takes advantage of the latest technologies, as well as 50 years of “lessons learned” in the aerospace industry. By implementing an automated countdown, simplifying systems and delivering fully integrated rockets to the launch pad, SpaceX has developed launch procedures requiring crews that are an order of magnitude smaller than standard.

Incorporating hundreds of innovations in technical design and launch operations, along with a low-overhead corporate environment, SpaceX is demonstrating that through simplicity, both reliability and low cost can be achieved in commercial spaceflight.

The chart below provides a few examples of payloads and orbits our vehicles can accommodate. Please contact us with your specific needs.

**Vehicles, Orbits and Payloads**

VEHICLE	ORBIT	FROM CAPE CANAVERAL	FROM KWAJALEIN
Falcon 1	Low Earth Orbit	--	420 kg (9.1°)
Falcon 1e	Low Earth Orbit	--	1010 kg (9.1°)
Falcon 9	Low Earth Orbit	10,450 kg (28.5°)	--
“	Geosync. Transfer Orbit	4,540 kg (28.5°)	--
Falcon Heavy	Low Earth Orbit	53,000 kg (28.5°)	--
“	Geosync. Transfer Orbit	19,000 kg (28.5°)	--

- Falcon 1 is the world's first privately developed liquid fuel rocket to achieve Earth orbit. It provides the lowest cost per flight to orbit of a production rocket.
- Falcon 9 offers breakthrough reliability derived from the nine-engine first-stage configuration, and is the first American launch vehicle since the Saturn V to offer true engine-out redundancy and reliability.
- Dragon is the first privately developed spacecraft to return from Earth orbit, address cargo and crew transport requirements, and serve as a free-flying spacecraft to provide a versatile platform for in-space research, demonstrations and testing.



Falcon 1



Falcon 1e



Dragon Spacecraft



Falcon 9



Falcon Heavy

**Falcon 1** is the world's first privately developed liquid fuel rocket to achieve Earth orbit. Designed from the ground up, the two-stage, liquid oxygen and rocket-grade kerosene (RP-1) powered vehicle provides reliable and cost-efficient transport to low Earth orbit. The Falcon 1 first stage is designed for recovery and reuse.

Length:	21.3 m (70 ft)	Mass:	27,670 kg (61,000 lb)
Width:	1.7 m (5.5 ft)	1st Stage Thrust (vacuum):	418 kN (94,000 lbf)



Length:	24.7 m (81 ft)	Mass:	35,180 kg (77,555 lb)
Width:	1.7 m (5.5 ft)	1st Stage Thrust (vacuum):	569 kN (128,000 lbf)



### First Stage

- Flight pressure stabilized architecture developed by SpaceX provides optimization between a fully pressure stabilized design and a heavier isogrid design.
- Powered by a single SpaceX Merlin turbopump engine, the simplest possible design for a pump-fed engine.
- Hold-before-liftoff system enhances reliability. After engine start, Falcon 1 is held down until all vehicle systems are verified to be functioning normally before release for liftoff.
- Stage separation occurs via a pneumatic pusher system, released by dual initiated separation bolts, which have a zero failure track record in prior launch vehicles.

### Second Stage

- Tanks are precision machined from aluminum plate with integral flanges, minimizing the number of welds necessary. Major circumferential welding is performed by an automated welding machine, reducing the potential for error and ensuring consistent quality.
- Powered by a single SpaceX Kestrel engine, featuring a simple pressure-fed system, and dual redundant igniters for added reliability of restart.

### Payload Accommodation

- Benign flight environment.
- Large available volume for this payload class.
- Standard mechanical interface with a low-shock, flight-proven separation system.

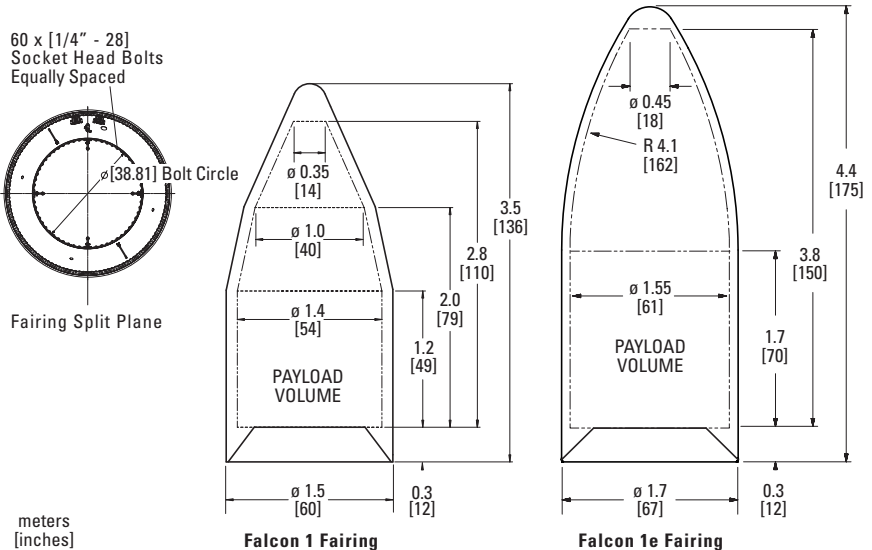

FALCON 1

# FALCON 9

**Falcon 9** is a flight-proven two-stage, liquid oxygen and rocket-grade kerosene (RP-1) powered launch vehicle. It is in the Evolved Expendable Launch Vehicle (EELV) class with a 5.2 m (17 ft) fairing. Falcon 9 can deliver large payloads to low Earth orbit (LEO), geosynchronous transfer orbit (GTO), and destinations beyond.

Falcon 9 offers breakthrough reliability derived from the nine-engine, single-tank first-stage configuration. Falcon 9 is the first American launch vehicle since the Saturn V to offer true engine-out redundancy and reliability.

Length:	69.2 m (227 ft)	Mass at liftoff:	480,000 kg (1,058,000 lb)
Width:	3.6 m (12 ft)	Thrust at liftoff:	5.6 MN (1,260,000 lbf)



## First Stage

- Tank walls and domes are made from aluminum-lithium chosen for its superior performance and high strength-to-weight ratio.
- Tank is friction stir-welded, the highest strength and most reliable welding technique available.
- Powered by nine SpaceX Merlin engines.
- Hold-before-liftoff system enhances reliability. After engine start, Falcon 9 is held down until all vehicle systems are verified to be functioning normally before release for liftoff.

## Second Stage

- Tank is a shorter version of the first-stage tank and uses most of the same tooling, material and manufacturing techniques – resulting in significant cost savings in vehicle production.
- A single Merlin engine, with a larger vacuum nozzle for efficiency, powers the Falcon 9 upper stage. For added reliability, the engine has dual redundant pyrophoric igniters and four injection ports to ensure engine ignition.

## Payload Accommodation: 5.2 meter Fairing

meters  
[inches]

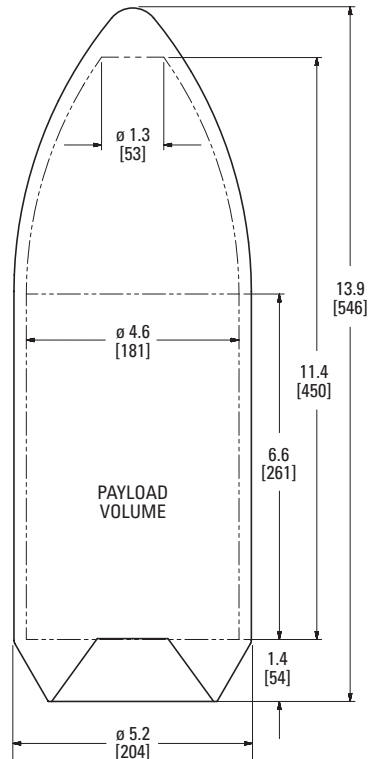
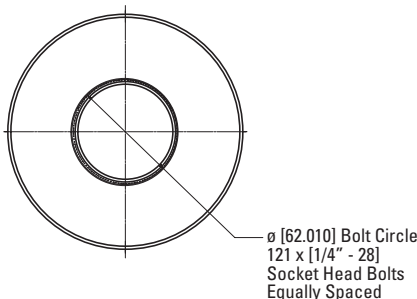

**Falcon Heavy**, the world's most powerful rocket, represents SpaceX's entry into the heavy lift launch vehicle category. With the ability to carry satellites or interplanetary spacecraft weighing over 53 metric tons to low Earth orbit (LEO), Falcon Heavy can lift nearly twice the payload of the next closest vehicle, the US Space Shuttle, and more than twice the payload of the Delta IV Heavy.

The first stage is made of three nine-engine cores, which are used as the first stage of Falcon 9. With the stage already designed to support the additional loads of this configuration and with common tanking and engines across both vehicles, development and operation of the Falcon Heavy will be highly cost-effective.

Length:	69.2 m (227 ft)	Mass at liftoff:	1,400,000 kg (3,100,000 lb)
Width:	3.6 m (12 ft)	Thrust at liftoff:	17 MN (3,800,000 lbf)



**First Stage (core and boosters)**

- Tank walls and domes are made from aluminum-lithium chosen for its superior performance and high strength-to-weight ratio.
- Each core powered by nine SpaceX Merlin engines.
- Cross-feeding of propellant leaves the core stage nearly full upon booster separation.
- Hold-before-liftoff system enhances reliability. After engine start, Falcon is held down until all vehicle systems are verified to be functioning normally before release for liftoff.

**Second Stage**

- Tank is a shorter version of the first-stage tank and uses most of the same tooling, material and manufacturing techniques – resulting in significant cost savings in vehicle production.
- A single Merlin engine, with a larger vacuum nozzle for efficiency, powers the Falcon Heavy upper stage. For added reliability, the engine has dual redundant pyrophoric igniters and four injection ports to ensure engine ignition.

**Payload Accommodation: 5.2 meter Fairing**

meters  
[inches]

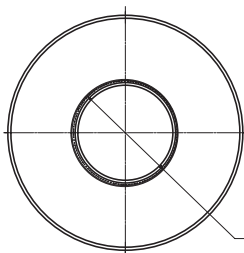

ø [62.010] Bolt Circle  
121 x [1/4" - 28]  
Socket Head Bolts  
Equally Spaced

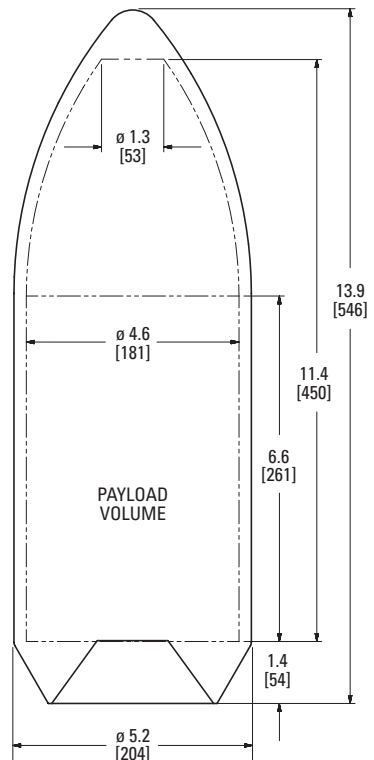



<b>Customer</b>	<b>Date<sup>†</sup></b>	<b>Vehicle</b>
DARPA Demo Flight 1	√ March 24, 2006	Falcon 1
DARPA Demo Flight 2	√ March 20, 2007	Falcon 1
DoD ORS Office, ATSB (Malaysia) & NASA	√ August 2, 2008	Falcon 1
Falcon 1 Flight 4	√ Sept. 28, 2008	Falcon 1
ATSB (Malaysia)	√ July 13, 2009	Falcon 1
Falcon 9 Inaugural Flight	√ June 4, 2010	Falcon 9
NASA COTS – Demo C1	√ Dec. 8, 2010	Falcon 9 / Dragon
NASA COTS – remaining	2011	Falcon 9 / Dragon
ORBCOMM – multiple flights	2011-2014	Multiple
MDA Corporation (Canada)	2012	Falcon 9
NASA Resupply to ISS – 12 flights	2012-2015	Falcon 9 / Dragon
Falcon Heavy Demo Flight	2012	Falcon Heavy
SES (Europe) – 2 flights	2013	Falcon 9
Thaicom (Thailand)	2013	Falcon 9
NSPO (Taiwan)	2013	Falcon 9
DragonLab – 2 flights	2014-2015	Falcon 9 / Dragon
Space Systems/Loral	2014	Falcon 9
CONAE (Argentina) – two flights	2014-2015	Falcon 9
Spacecom (Israel)	2014	Falcon 9
Astrium (Europe)	2015	Falcon 1e
Bigelow Aerospace	2014	Falcon 9
Iridium – multiple flights	2015-2017	Falcon 9

# TO ORBIT



September 28, 2008 – Falcon 1 becomes the first privately developed liquid fuel rocket to achieve Earth orbit.

July 13, 2009 – Delivery of our first commercial satellite to orbit for ATSB of Malaysia.

June 4, 2010 – SpaceX successfully completed the first flight of our nine-engine Falcon 9 launch vehicle for delivering larger payloads to LEO and beyond.

December 8, 2010 – Second Falcon 9 launch and fully successful inaugural flight of the Dragon, which became the first private spacecraft to return to Earth from orbit.

Designed for the highest levels of reliability, SpaceX's Falcon vehicles lead the world market in providing the lowest cost to orbit of any launch system.



SpaceX offers open and fixed pricing for all customers, including a best price guarantee. Modest discounts are available for contractually committed, multi-launch purchases. Prices are in US dollars.

Please contact us for details at [sales@spacex.com](mailto:sales@spacex.com)

### Standard Launch Prices for 2013 Missions

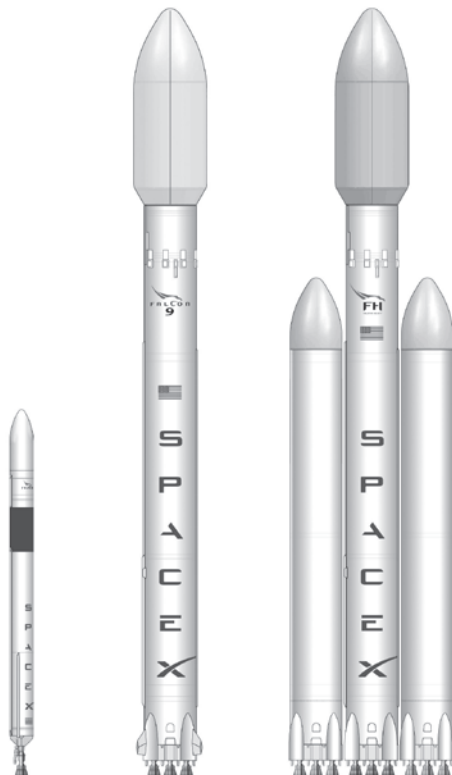

**Falcon 1e**  
**\$10.9M\***

**Falcon 9**  
**\$54M to \$59.5M**

**Falcon Heavy**  
**\$80M to \$125M**

\*Falcon 1e is on hold until early 2012.