

A New Standard Volume Indicator and Reference Level

H. A. Chinn, D. K. Gannett, and R. M. Morris

Copyright © 1940 IRE now IEEE. Reprinted from *Proceedings of the I.R.E.*, Vol. 28, 1940 January, pages 1...17.

This material is posted here with permission of the IEEE. Such permission of the IEEE does not in any way imply IEEE endorsement of any of Audio Engineering Society's products or services. Internal or personal use of this material is permitted. However, permission to reprint/republish this material for advertising or promotional purposes or for creating new collective works for resale or redistribution must be obtained from the IEEE by sending a blank email message to pubs-permissions@ieee.org.

By choosing to view this document, you agree to all provisions of the copyright laws protecting it.

John G. (Jay) McKnight, Chair
AES Historical Committee
2006 Aug 21

A New Standard Volume Indicator and Reference Level*

H. A. CHINN†, MEMBER, I.R.E., D. K. GANNETT‡, MEMBER, I.R.E.,
AND R. M. MORRIS§, ASSOCIATE, I.R.E.

Summary—In recent years it has become increasingly difficult to correlate readings of volume level made by various groups because of differences in the characteristics and calibrations of the volume indicators used. This paper describes a joint development by the Columbia Broadcasting System, National Broadcasting Company, and Bell Telephone Laboratories which resulted in agreement upon, and standardization in the respective broadcast and telephone plants of a new copper-oxide-rectifier type of volume indicator having prescribed dynamic and electric characteristics; a new reference level based on the calibration of the new instrument with a single-frequency power of 1 milliwatt; and a new terminology, the readings being described in "v." It is hoped that other users of volume indicators will join in the adoption of these new standards.

The paper gives in considerable detail the technical data and considerations on which was based the choice of the characteristics of the new volume indicator and the other features of the new standards. Particular attention is paid to the technical data supporting the decision to make the new volume indicator approximately a root-mean-square rather than a peak-reading type of instrument.

INTRODUCTION

THE student of electrical engineering, when introduced to alternating-current theory, learns that there are three related values of a sine wave by which its magnitude may be expressed. These are the average value, the root-mean-square (or effective) value, and the peak (or crest) value. Certain fundamental electrical measuring devices provide means for determining these values. As the student's experience broadens, he becomes familiar with complex, non-sinusoidal periodic waves and finds that these waves have the same three readily measured values. He learns how to determine from the problem under consideration whether the average, the root-mean-square, or the peak value of the wave is of primary importance.

If the student later enters the field of communication engineering, he immediately encounters waves which are both very complex and nonperiodic. Examples of typical speech and music waves are shown in the oscillograms of Fig. 1. When an attempt is made to measure such waves in terms of average, root-mean-square, or peak values, it is found that the results can no longer be expressed in simple numerical terms, as these quantities are not constant but variable with time and, moreover, are apparently affected by the characteristics of the measuring instrument and the technique of measurement. However, the communications engineer is vitally concerned with the magnitude of waves of the sort illustrated, as he must design and operate systems in which they are amplified by

vacuum tubes, transmitted over wire circuits, modulated on carriers, and otherwise handled as required by the various communication services. He needs a practical method of measuring and expressing these magnitudes in simple numerical fashion.

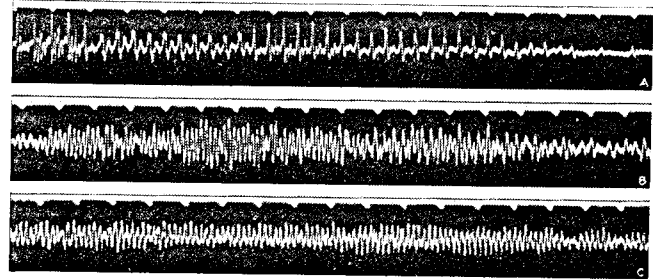

Fig. 1—Examples of program wave forms.
A—Male speech ("How many")
B—Male solo with orchestral accompaniment
C—Dance orchestra

Note: Frequency of timing waves is 60 cycles per second.

This need may be better appreciated by considering the communication systems employed for broadcasting. These are very complicated networks spread over large geographical areas. A typical network may include 15,000 miles of wire line and hundreds of amplifiers situated along the line and in the 50 to 100 connected broadcast stations. Every 15 minutes during the day the component parts of such a system may be shifted and connected in different combinations in order to provide for new points of origin of the programs, and for the addition of new broadcast stations and the removal of others from the network. In whatever combination the parts of the system are put together, it is necessary that the magnitude of the transmitted program waves, at all times and at all parts of the system, remain within the limits which the system can handle without impairment from overloading or noise. To accomplish this, some convenient method of measuring the amplitude of program waves is needed.

These considerations led to the conception of a fourth value, known as "volume," whereby the magnitude of waves encountered in electrical communications, such as telephone speech or program waves, may be readily expressed. This value is a purely empirical thing, evolved to meet a practical need. It is not definable by means of a precise mathematical formula in terms of any of the familiar electrical units of power, voltage, or current. Volume may be defined in terms of the reading of an instrument known as a volume indicator, which has specified dynamic and

* Decimal classification: R243. Original manuscript received by the Institute, June 29, 1939; revised manuscript received, August 14, 1939. Presented, Pacific Coast Convention, San Francisco, Calif., June 29, 1939, and Fourteenth Annual Convention, New York, N. Y., September 20, 1939.

† Columbia Broadcasting System, Inc., New York, N. Y.

‡ Bell Telephone Laboratories, Inc., New York, N. Y.

§ National Broadcasting Company, New York, N. Y.

other characteristics and which is calibrated and read in a prescribed manner. Because of the rapidly changing character of the program wave, the *dynamic characteristics* of the instrument are fully as important as the value of sine-wave power used for calibration. The readings of volume have been customarily expressed in terms of decibels with respect to some volume level chosen as the "reference" level.

In the past, because of a lack of complete understanding of the matter, there has been little uniformity in the design and use of volume indicators, although attempts have been made by some organizations toward standardization. The devices used were of the root-mean-square and peak-reading types having slow, medium, or high pointer speeds; half- or full-wave rectifiers; critically to lightly damped movements, and reference to levels based on calibrations with 10^{-9} , 1, 6, 10, $12\frac{1}{2}$, or 50 milliwatts in 500 or 600 ohms. This great array of variables led to considerable confusion and lack of understanding, especially when an attempt was made to correlate the measurements and results of one group with those of another.

To remedy this situation, the Bell Telephone Laboratories, the Columbia Broadcasting System, and the National Broadcasting Company entered upon a joint development effort during January, 1938, with the object of pooling their knowledge and problems, of pursuing a co-ordinated development program, and of arriving at a uniform practice of measuring volume levels. The outcome of this work is a new volume indicator, a new reference volume level, and new terminology for expressing measurements of volume level. The results of this development work have been discussed with, and approved by, more than 24 other organizations, and were presented at an open round-table conference at the Annual Convention of the Institute of Radio Engineers on June 17, 1938. During May, 1939, it was adopted as standard practice by the above two broadcast companies and the Bell System, and it is hoped that they will be joined by others. It is the purpose of this paper to describe the new standards and the considerations which led to their adoption.

EARLY HISTORY OF VOLUME INDICATORS

As a background for understanding the present development, it will be helpful to review briefly the early history of volume indicators. The particular occasion for the development of the first volume indicator was the setting up of the public-address system which enabled the ceremonies attendant upon the burial of the Unknown Soldier on Armistice Day, 1921, to be heard by large audiences at Arlington, New York, and San Francisco.¹ It was noted in some of the preliminary tests that distortion due to overloading of an amplifier was more objectionable when heard in

a loud speaker than when heard in an ordinary telephone receiver. Consequently, to avoid overloading the telephone repeaters when they were used on the public-address circuits, a device was proposed which would give visual indication on an instrument when the speech level was such as to cause the telephone repeaters to overload.

Further development of this idea led to the experimental device which was used in the Armistice Day ceremonies and which later, with no fundamental change, became the well-known 518 and 203 types of volume indicator. This device consisted of a triode vacuum tube functioning as a detector, to the output of which was connected a direct-current milliammeter. Associated with the input was a potentiometer for adjusting the sensitivity in 2-decibel steps. The method of using the device was to adjust the potentiometer so that the maximum movement of the milliammeter needle reached the mid-scale point on an average of about once every 10 seconds, occasional greater deflections being disregarded. The volume level was then read from the setting of the potentiometer which was marked in decibels with respect to a reference volume level.

The reference level was chosen as that level of speech which, when transmitted into the long telephone circuits, would cause the telephone repeaters with which they were equipped to be just on the verge of overloading as evidenced by audible distortion. The gains of the telephone repeaters were normally adjusted so that the level at their outputs was 10 decibels higher than at the sending end of the circuit. Reference volume was therefore specifically defined as 10 decibels below the maximum speech level which could be satisfactorily transmitted through the particular amplifier and vacuum tubes used in the telephone repeaters. This level was determined experimentally and the potentiometer steps of the volume indicator were marked accordingly. This reference volume was also approximately the volume delivered over a short loop by the then standard subscriber's telephone set when spoken into with a fairly loud voice.

It is apparent that the volume indicator was born in response to a definite need, and it has filled an important niche in the rapidly growing radio broadcast industry and in other communication fields. Large numbers of volume indicators similar to this early type have continued in service to the present time.

Frequently, it is characteristic of a rapidly expanding art that at first standards multiply, and finally a point is reached where simplification and agreement upon a single standard becomes imperative. This has occurred in connection with volume indicators and since the development of the first one, a variety of instruments have been produced by the various manufacturers and have come into service in the plants of the different companies. These instruments had differ-

¹ W. H. Martin and A. B. Clark, "Use of public address system with telephone lines," *Trans. A.I.E.E.*, vol. 42, p. 75; February, (1923).

ent calibrations and characteristics and there was little correlation between their readings.

A further divergence occurred, regarding the philosophy of the calibration of the original type of volume indicator. One view recognized no correlation between the point at which the galvanometer was normally read on peaks (the 30-division point on the scale, Fig. 12) and the power of 6 milliwatts used for calibration. When calibrating the instrument on 6 milliwatts of sine-wave energy in 500 ohms, the galvanometer would read 22 divisions with the associated sensitivity switch on step zero. There was not intended to be any correlation between this calibrating power and reference volume. Nevertheless, many people were led by this technique of calibration to refer to the volume indicator as a 6-milliwatt instrument. This idea was furthered by the fact that the vacuum tube, to whose speech-carrying capacity the reference volume was originally referred, has a nominal full-load capacity on sine waves of 60 milliwatts. The reference volume being defined as 10 decibels below the maximum output of this tube, it was natural to try to relate this reference volume to the corresponding figure of 6 milliwatts for sine waves.

A second view was based on the experimental fact that when the potentiometer controlling the sensitivity was set at "0 decibels," a sine-wave potential of 2.5 volts (root-mean-square) applied to the volume indicator caused a deflection to mid-scale (scale reading of 30 divisions). This was equivalent to 12.5 milliwatts in a 500-ohm circuit, and the supporters of this view therefore referred to the volume indicator as a 12.5-milliwatt instrument.

Thus the same volume indicator, having the same sensitivity and giving the same readings of volume level, was variously referred to as a 6-milliwatt and a 12.5-milliwatt device. This increased the difficulty of co-ordination between the plants of the different companies which are interconnected in rendering broadcast service.

Some degree of standardization of the technique of reading volume levels had already been made within different organizations both here and abroad. The importance of the present development lies not only in the particular merits of the proposed standards, but also in the fact that they have been jointly developed and adopted by three of the larger users of volume indicators, and have been approved by many others. Thus there is a good prospect that the needed standardization is about to be realized, and that all will shortly use the same instruments, the same reference levels, the same terminology, and the same nominal value of circuit impedance.

CHOICE OF PEAK VERSUS ROOT-MEAN-SQUARE TYPES

General

The first important decision to be made and one which would affect the entire character of the develop-

ment was whether the new volume indicator should be of the root-mean-square or of the peak-reading type. These two types of instrument represent two schools of thought. The peak-reading instrument is favored for general use by many European engineers and is specified by the Federal Communications Commission for use as modulation monitors in this country. The root-mean-square type has, however, been commonly employed in this country on broadcast program networks and for general telephone use. In view of the importance of the decision and the difference of opinion that has existed, the data on which the choice was made are given below in considerable detail.

In accord with common practice, the terms "root-mean-square" and "peak-reading" are used rather loosely throughout this paper. The essential features of a root-mean-square instrument are some kind of rectifier or detector and a direct-current milliammeter. The latter is not especially fast, generally requiring tenths of a second to reach substantially full deflection. If a sufficiently slow wave is applied, say one whose frequency is one or two cycles per second, the instrument can follow it and the true peaks of the wave will be indicated, but when much higher frequency waves are applied, such as the complex speech or program waves, the instrument is too slow to indicate the instantaneous peaks but averages or integrates whole syllables or words. As shown by tests and practical experience, it is of secondary importance whether the detector actually has a root-mean-square (or square-law) characteristic, or has a linear or some intermediate characteristic.

A peak-reading instrument capable of truly indicating the sharpest peak which might occur in a high-quality program wave would have to respond to impulses lasting only a very small fraction of a millisecond. Cathode-ray oscilloscopes or gas-tube trigger circuits are capable of doing this and, therefore, might be used as peak-reading volume indicators. However, the so-called peak-reading volume indicators used in practice, designed to give a visual indication on an instrument, are far from having the above speed although they are much faster than the root-mean-square instruments. They generally respond to impulses whose duration is measurable in hundredths or thousandths of a second and, therefore, truly indicate the peaks of sine-wave voltage whose frequency does not exceed, say, 50 to 100 cycles per second. They are similar to the root-mean-square instruments in that they are not fast enough to indicate the instantaneous peaks of speech or program waves but tend to average or integrate a number of peaks of the wave.

A feature of the usual peak-reading instrument which from the analytical standpoint is of secondary importance, is that it is usually given a characteristic of very slow decay as well as rapid response. This is

usually accomplished by a circuit such as illustrated in Fig. 2 which shows the principle of the experimental instrument used in the tests described later. The 0.01-microfarad condenser is charged through a full-wave vacuum-tube rectifier, the rates of charge and discharge being determined by the resistances. The direct-current amplifier and direct-current milliammeter indicate the charge on the condenser. The advantage of making the discharge rate of the condenser very slow is that the direct-current milliammeter need not then be particularly fast and, moreover, the ease of reading the instrument is greatly increased.

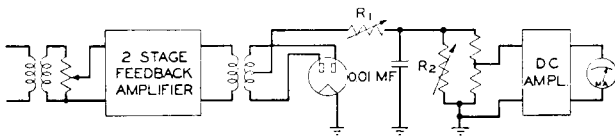

Fig. 2—Schematic diagram of experimental peak-reading volume indicator.

From the above analysis it is seen that the root-mean-square and the peak-reading instruments are essentially similar and differ principally in degree. Both indicate peaks whose durations exceed some value critical to the instrument and both average or integrate over a number of peaks the shorter, more rapid peaks encountered in speech or program waves. Either may have a linear or a square-law detector, or one of some intermediate characteristic. The important difference between the two types lies in the speed of response as measured by the length of impulses to which they will fully respond, that is, in the time over which the complex wave is integrated.

A general-purpose volume indicator may be called upon to serve a number of uses, such as:

- (a) Indication of a suitable level for a speech or program wave to avoid audible distortion when transmitted through an amplifier, program circuit, radio transmitter, or the like.
- (b) Checking the transmission losses or gains in an extended program network by simultaneous measurements at a number of points on particular peaks or impulses of the program wave which is being transmitted.
- (c) The indication of the comparative loudness with which programs will be heard when finally converted to sound.
- (d) The indication of a satisfactory level to avoid interruption of service due to instantaneous overloads tripping protective devices in a radio transmitter, damage to sound recording systems, etc.
- (e) Sine-wave transmission measurements.

These services are different in nature and the ideal requirements for an instrument for each may not necessarily be the same. One instrument to serve them all must, therefore, be a compromise. From the standpoint of the companies engaged in this development, items (a), (b), and (c) in the above list were considered

to be the most important and therefore attention was first directed to the relative merits of the two types of volume indicators with respect to them.

Aural Distortion Due to Overload

Tests of volume indicators as overload indicators with aural distortion as the criterion (item (a)) had previously been made on a number of occasions and more tests were undertaken during the present development. The general procedure in such tests is to determine for some particular amplifier the volume level at its output at which distortion due to overloading can just be heard by a number of observers on each of a variety of programs. The volume levels thus determined are read on the various volume indicators which are being compared. The best instrument is considered to be the one whose readings are most nearly alike for all the programs when overloading can just be detected.

The sole criterion of distortion due to overloading is the judgment of observers, since it is the final reaction on listeners which is of importance. This judgment is not subject to exactness of measurement, but is in fact somewhat of a variable, even with conditions unchanged and with the most experienced observers. For significant results to be obtained, therefore, a careful technique of conducting the tests is required, many observations must be made, and statistical methods of analyzing the resultant data must be employed.

The arrangement of equipment and circuits used in these tests is shown in simplified form in Fig. 3. A source of program, which may be a phonograph pickup, a direct microphone pickup, or a program circuit, is connected through control circuits to the amplifier which is to be overloaded, and thence through additional circuits to a loud speaker. The loud speaker employed in the tests reported here was a special high-quality two-unit loud speaker having a response which is substantially flat from 40 to 15,000 cycles per second.² Including the power amplifier used with it, the over-all response of the system was substantially uniform from 40 to 11,000 cycles.

The arrangement of the circuit is such that the volume level at the output of the test amplifier may be raised or lowered while keeping the over-all gain of the system constant. Two controls are provided for this purpose. One, operated by a key, transfers a 15-decibel loss from ahead to behind the test amplifier. This permits comparing a test condition with a reference condition in which the load on the amplifier is 15 decibels lower, while the loudness with which the program is heard remains the same for either condition. The other control, represented in Fig. 3 by the coupled attenuators, permits the load on the amplifier for the test condition to be varied, also without changing the

² E. C. Wente and A. L. Thurax, "Auditory perspective—loud speakers and microphones," *Elec. Eng.*, vol. 53, pp. 17-24; January, (1934).

loudness. The volume indicators to be compared are connected for convenience, to a point where the volume level is unaffected by the controls. Their readings are corrected for each test by the measured loss or gain between the point where they are situated and the output of the test amplifier, so as to express the levels which would be read at the amplifier output.

Two techniques were employed for conducting tests with this equipment. In one, the individual method, a single observer at a time listens to the program and adjusts the volume level at the output of the amplifier by means of the coupled attenuators, until he determines the point at which distortion due to overloading is just audible, when the key is operated from the reference to the test condition. This is repeated for a number of different programs and observers until a large number of observations have been obtained. The volume levels indicated by the different volume indicators at the amplifier output are determined for each observation. These are found to have a considerable spread, due not only to the differences in the nature of the programs but also to differences in the acuity of perception of the distortion by the various observers. The method of analyzing the data is described later.

In the second technique, the group method, a group of observers simultaneously listens to a program which is repeated with the key operated alternately to the test and reference positions. The two conditions are distinguished to the observers (but not identified as to which is which) by a letter associated with each condition in an illuminated sign. The letters *A*, *B*, and *C* are used, two being chosen at random for each test. A vote is taken as to which condition, designated

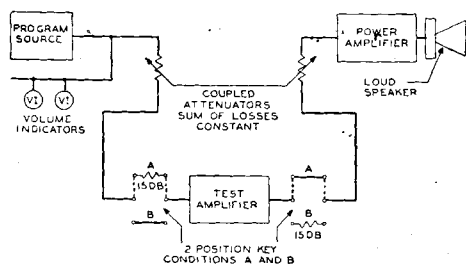

Fig. 3—Arrangements for determining volume level at which overload of amplifiers is audible.

by one of the two letters employed in the particular test, is preferred with respect to freedom from distortion. A number of such tests, covering the range from a level below the point where distortion can be detected by anyone to a level high enough for all to observe distortion, establishes a curve between the per cent of observers correctly choosing the reference condition as having the least distortion, and the amplifier output level as read by each volume indicator used in the tests. Similar curves are determined for a number of kinds of program material, and for purposes of comparison the overload point for each program is taken

from the point on the curve for each volume indicator, where 80 per cent³ of the observers voted correctly.

As noted, judgment tests of this sort require many observations and checks to obtain reliable results. A larger volume of data is available for the individual method, so the results from tests made by that method have been chosen to be reported here. Some tests have also been made with the group method and, while the results are less conclusive, they substantiate those recorded below.

Tests by the individual method to compare peak-reading and root-mean-square volume indicators have been carried out a number of times during the past two years. In each of these tests a number of observers have taken part and a number of samples of program material of a variety of types have been employed. For the majority of the tests, the sources of program were high-quality recordings, convenient because of the ease and exactness with which the programs could be repeated. For some of the tests, however, actual speakers and musical instruments were employed with direct microphone pickup.

A number of the types of volume indicators in common use were represented in these tests. Since the 700A volume indicator was common to all of the tests, it has been chosen to represent the root-mean-square type of volume indicator in the data presented below. The peak-reading type was represented by the especially constructed experimental instrument, whose fundamental circuit is shown in Fig. 2. The resistances controlling the rates of charge and discharge of the condenser were adjustable, permitting a range of characteristics to be obtained. The adjustments for which the data referred to below were obtained, correspond to a rate of charge of the condenser such that impulses of single frequency applied to the input for 0.025 second would give a reading within 2 decibels of the reading obtained with a sustained wave of the same amplitude. The rate of discharge of the condenser was about 19 decibels per second. These rates are generally similar in magnitude to those specified by the International Consulting Committee on Telephone Transmission (the C.C.I.F.) for broadcast service, and by the Federal Communications Commission for modulation monitors.

The direct-current amplifier and direct-current milliammeter which indicates the charge on the condenser included features, not shown in the simplified sketch, which made the response logarithmic. The instrument had a substantially uniform decibel scale covering a range of 50 decibels.

The data from four different series of tests, made at different times, were collected in one body, and distribution curves were plotted showing the relative frequency of occurrence among the data of the different levels at which incipient overload was detected.

³ W. B. Snow, "Audible frequency ranges of music, speech and noise," *Jour. Acous. Soc. Amer.*, vol. 3, pp. 155-166; July, 1931.

Curves for tests on a Western Electric 94B amplifier, which is an amplifier designed with negative feedback and therefore having a relatively sharp cutoff, similar to a radio transmitter, are illustrated in Fig. 4. It will be noted that the curve obtained with the root-mean-square volume indicator has a slightly greater spread than that for the peak-reading volume indicator. Twelve different observers took part in these tests, and 13 samples of program were employed, including male and female speech, dance music, piano, violin, and brass-band selections.

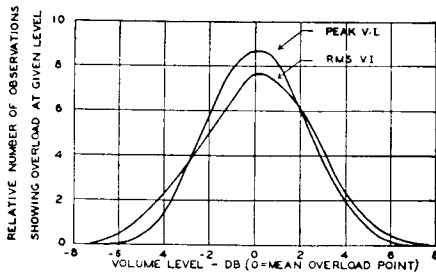

Fig. 4—Distribution of overload points.

The data may more readily be interpreted when plotted in the form of cumulative distribution curves, obtained by integrating the above distribution curves. Cumulative curves for the data just referred to are shown in Fig. 5. For convenience and ease of interpretation, these curves have been plotted on "probability" rather than rectangular co-ordinates, as probability co-ordinates have the property of making data whose distribution follows a normal law⁴ form a straight line. It will be noted that the experimentally determined points actually fall so nearly on straight lines that it is reasonable to assume straight lines to represent them. It is likely that, with a greater volume of data, still greater conformity to the straight lines drawn would be obtained.

In order to superpose the curves for the two volume indicators, the levels are plotted in decibels with respect to the average overload level determined from the tests. When calibrated to read alike on the same sine-wave power, the experimental peak-reading instrument (with the adjustments described above) reads on the average 7.4 decibels higher on actual programs than the root-mean-square instrument used in the tests.

Now let it be imagined that the test amplifier is the one critical link in a broadcast network and that an operator is given the duty of satisfactorily adjusting the volume levels through the amplifier using either of the two volume indicators tested. If he lets the louder portions of the programs just reach the volume level marked "0 decibel" on the curves, it will make no difference which volume indicator he uses. In either case, on the average, half of the listeners will hear distortion when the program is loudest. However, this result would probably be considered too poor, so

⁴ The "normal" law has the form $y = Ae^{-ax^2}$.

suppose the maximum level is lowered 3.5 decibels. Referring to the curves, it is seen that if the peak-reading volume indicator is used, only about 5 per cent of the listeners will now, on the average, hear distortion on the loudest program passages, while if the root-mean-square instrument is used, about 10 per cent will hear distortion. To reduce the latter figure to 5 per cent would require lowering the maximum volume level another decibel. Thus with this criterion, the peak instrument has a slight advantage, as it would permit the transmission of a 1-decibel higher average volume level for the same likelihood of distortion being heard.

The above statements assume that the observers and programs used in the tests just described were representative of the listening public and the programs they hear. Actually, the observers were trained by experience in making many tests and were no doubt much more critical than the average listener. Moreover, the conditions under which the tests were performed, with the availability of frequent comparison with the undistorted reference condition, were more conducive to critical detection of overload than are average listening conditions. These facts, together

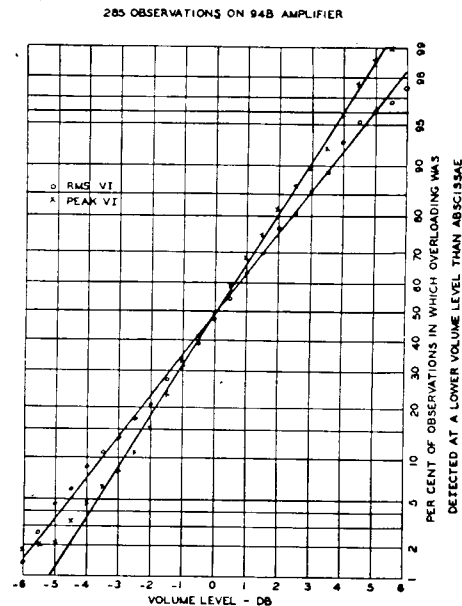

Fig. 5—Comparison of peak versus root-mean-square volume indicators as overload indicators (using Western Electric 94B amplifiers).

with the inevitable inability of the control operator in practice to make his adjustments perfectly in anticipation of the coming changes in the programs, tend to make the real practical advantage of one instrument over the other considerably less than shown by the tests. A further factor reducing the importance of the small differences shown by the tests is the growing use of volume-limiting amplifiers at critical points in a broadcast system, such as at the radio broadcast stations, which automatically prevent the transmission of excessive levels.

Another cumulative distribution curve is shown in Fig. 6, representing similar tests on a Western Electric 14B program amplifier. This is a simple push-pull triode amplifier without negative feedback and therefore having a more gradual cutoff than the 94B. (The gain-versus-output-power-level curves at 1000 cycles per second are shown in Fig. 7 for the two amplifiers.) It will be seen from Fig. 6 that the data for the two volume indicators show no significant difference and that the single curve equally well represents either set of data in the region of interest. Somewhat fewer data are represented by this curve and the agreement with the normal law is not quite so close as in the previous case.

The peak-reading instrument with the adjustment used in these tests, although having characteristics

in the form which most directly indicates the comparative performance of the two types of volume indicators. However, a breakdown of the data with respect to the types of program may be of interest and is shown in Tables I and II for the data on the 94B amplifier shown previously in Figs. 4 and 5.

179 OBSERVATIONS ON 14B PROGRAM AMPLIFIER

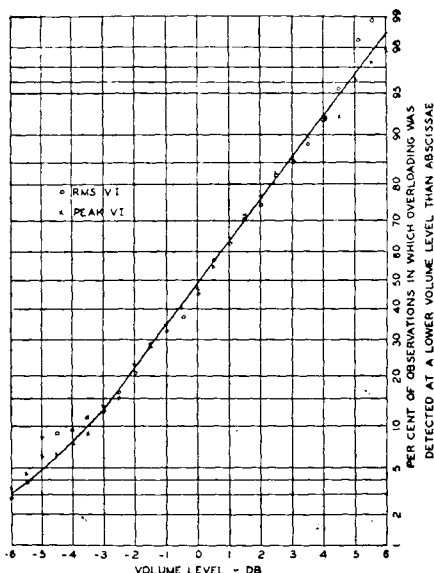

Fig. 6—Comparison of peak versus root-mean-square volume indicators as overload indicators (using Western Electric 14B program amplifiers).

similar to those usually proposed for this type of device, is still far too slow in response to indicate the true instantaneous peaks of the program wave. The question naturally arises, therefore, whether any greater difference would be indicated if the peak-reading instrument were made sufficiently fast in response to indicate the actual instantaneous peaks. To check this point, some tests similar to those described above were made, using a gas-tube trigger circuit capable of measuring the true instantaneous peaks. The results of these tests, using the 94B amplifier, are shown in Fig. 8. Although a smaller number of observations are included in these data, the results show conclusively that there is no substantial difference between the experimental peak-reading volume indicator and the faster trigger-tube arrangement, in their performance on actual program waves.

The data from the tests have been presented above

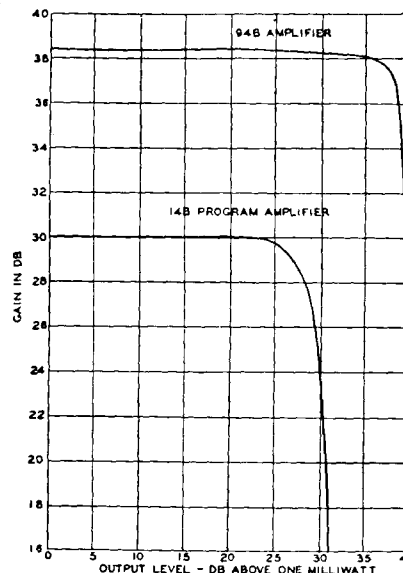

Fig. 7—Gain-versus-load characteristics of amplifiers.

It will be observed in Table I that the average overload points for the different types of programs fall within a range of about 2 decibels for either volume

41 OBSERVATIONS ON 94B AMPLIFIER

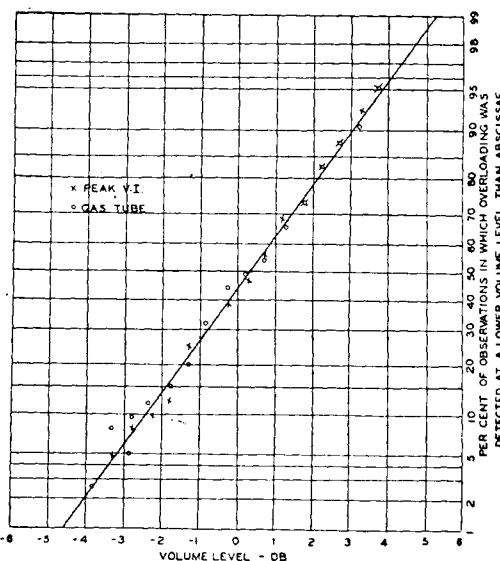

Fig. 8—Comparison of experimental peak-volume indicator with gas-tube-trigger device as overload indicator.

indicator. However, it will be noted that with the root-mean-square instrument the average overload point for speech is about 2 decibels lower than for music, while there is no significant difference with the peak instrument. This undoubtedly is because speech waves have a higher "peak-factor" (ratio of peak to root-mean-square values) than music.

Table II shows the spread of the overload points (difference between highest and lowest values) for the various tests on each type of program whose average is given in Table I. Most of the types of program show a significantly narrower spread for the peak than the root-mean-square instrument. For comparison with values taken from Figs. 5 and 6, discussed above, these spreads should be divided by two to show the difference between the lowest and the mean values.

TABLE I
AVERAGE OVERLOAD POINTS OF DIFFERENT KINDS OF PROGRAM
MEASURED AT THE OUTPUT OF THE 94B AMPLIFIER

Character of Program	Number of Tests	Total Number of Observations	Average Overload Point ¹	
			Root-Mean-Square Volume Indicator	Peak Volume Indicator
Male speech	8	81	22.1	31.9
Female speech	8	82	22.8	30.1
Piano	5	40	24.1	30.9
Brass band	4	25	24.1	31.0
Dance orchestra	5	42	24.7	29.4
Violin	1	15	25.8	31.1
Average speech	16	163	22.4	31.0
Average music	15	122	24.5	30.5
Grand average	31	285	23.3	30.7

¹ These tests antedated the new standards, and the values given are in decibels with respect to a reference point based on a single-frequency calibration of 0.006 watt in 600 ohms.

TABLE II
SPREAD OF OVERLOAD POINTS WHOSE AVERAGES
ARE GIVEN IN TABLE I

Character of Program	Root-Mean-Square Volume Indicator	Peak Volume Indicator
	decibels	decibels
Male speech	6.1	3.7
Female speech	4.6	2.5
Piano	3.6	4.9
Brass band	4.0	3.9
Dance orchestra	3.7	2.4
All types	7.3	5.9

It is concluded from the tests just described that the disadvantage in using root-mean-square instead of peak-reading volume indicators for controlling volumes to avoid aural distortion due to overloading, is substantially none when the overloading device does not have too sharp an overloading characteristic, and only slight when it does overload sharply. The explanation probably lies in the physiological and psychological factors involved in the ear's appreciation of overload distortion, which permit to pass unnoticed considerable amounts of distortion on rarely occurring instantaneous peaks of very short duration.

Peak Checking

A very important use of volume indicators is that of checking the transmission losses or gains along a program network by measurements made on the transmitted program material (item (b) in the list given earlier). The program circuits which make up the large program networks, are in continuous use for many hours each day and during that period are switched together in many combinations as required by the operating schedules. It is not convenient to interrupt service for sine-wave transmission measurements, hence, to check the transmission conditions

during service hours, it is the custom to take simultaneous readings at two or more points in the program networks on particular impulses of whatever program wave is being transmitted, co-ordinating these readings by the use of an order wire. On such readings, the root-mean-square type of instrument is far superior to the peak-reading type, because of phase distortion and slight nonlinearity in the program circuits. These effects are undetectable to the ear, but change the wave shape of the program peaks sufficiently to cause serious errors in the readings of the peak-type instrument. On the other hand they have no noticeable effect on the root-mean-square instruments.

Tests were made on this effect by taking readings on several kinds of programs at the beginning and end of a program circuit extending from New York to Chicago and return (about 1900 miles). The circuit was lined up so that either volume indicator read the

TABLE III
ERRORS RESULTING FROM USE OF PEAK-TYPE VOLUME INDICATOR
ON A LONG PROGRAM CIRCUIT

	Upper Frequency Limit of Program	
	5000 Cycles	8000 Cycles
	Decibels	Decibels
Male speech	-3.5	-4.5
Female speech	-1.5	-3.0
Dance orchestra	-2.0	-1.5
Brass band	-3.0	-2.0
Piano	-0.5	-1.5

same at both ends of the circuit on a 1000-cycle sine wave. In all the tests, the readings obtained on program material with the root-mean-square instrument at the two ends of the circuit agreed within a very few tenths of a decibel. The readings of the peak instrument, however, disagreed by the values shown in Table III, when the program material was applied to the circuit at the normal maximum operating level.

It is of interest that the errors shown by Table III are affected by the frequency range of the program material transmitted, being greater for the broader band. The frequency range was controlled by the use of low-pass filters inserted between the source of program and the line before the point at which the sending-end levels were read. Tests were also made of the effect of a 180-degree phase reversal at the center of the loop. This was found to increase the errors in some cases and to decrease them in others.

The large errors indicated in the table are, of course, intolerable. The effect of the line on the reading of the peak instrument is partly due to the cumulative effects of the slight nonlinearity in the many vacuum-tube amplifiers and loading coils in the circuit, and partly to phase changes which alter the wave front and amplitude of the peaks. It might be thought that phase changes which destroy some peaks would tend to create others. However, a Fourier analysis of a sharp peak will show that an exact phase relationship must exist between all of the frequency components. The probability that phase shift in a line will chance to cause all of the many frequency components of a

complex wave to align themselves in the relationship necessary to create a peak where none existed before; is very slight—indeed infinitesimal compared to the probability of the occurrence of a peak in the original wave.

Loudness

Another important consideration is the correlation between volume levels and the comparative loudness of different types of programs (item (c) in the list given earlier). This was tested by a method similar to the "group method," described above in connection with the tests on aural overload distortion. A group of observers was permitted to listen to alternate repetitions of a test program and a reference program, and was asked to vote upon which appeared the louder. A particular selection of male speech was used as the reference program for all of the tests and its level was kept constant. The test programs included several different types and several samples of each type of program. The samples of program were about 30 seconds in length. Each test program was presented at a number of levels covering a range from a low level where all the observers judged the reference program to be the louder to a higher value where all of them judged the test program to be the louder.

Thus, a curve was established for each type of program between the per cent of observers judging the test program to be the louder, and the level of the test program. A sample of such a curve is shown in Fig. 9. The 50 per cent point on the curve is interpreted as indicating the level of the test program at which it appears to the average observer to have the same loudness as the reference program. The test program is then set at this "equal-loudness" volume level and the levels of both test and reference programs are read with each of the types of volume indicators of interest. In this way, the figures given in Table IV were determined.

TABLE IV

Type of Program	Volume Indicator Readings for Same Loudness as Male Speech	
	New Volume Indicator	Peak Volume Indicator
Male speech	0	0
Female speech	-0.1	-2.2
Dance orchestra	+2.8	-2.2
Symphony orchestra	+2.7	-2.3
Male singing	+2.0	-2.5

It is evident from the figures in the table that there is no significant advantage for either type of volume indicator where loudness is the criterion.

Table IV shows that when the new volume indicator is used the musical programs must be 2 to 3 decibels higher than speech to sound equally loud. It is of interest to note that according to Table I this same difference was shown to exist between the average overload point of the 94B amplifier on speech and music, when measured with the root-mean-square

volume indicator. This would seem to indicate that if allowance is made for this difference between speech and music in controlling the volume levels to avoid overloading, they will also then sound equally loud to the listeners.

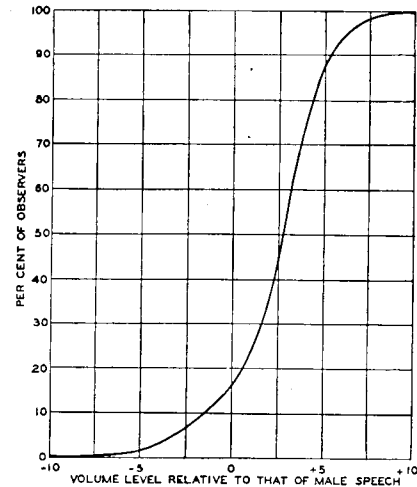

Fig. 9—Per cent of observers choosing symphony music at indicated volume levels to be louder than the male speech reference.

Choice of Type

The tests of aural distortion due to overload showed so slight a disadvantage for the root-mean-square instrument and the experiments on peak checking showed such a marked advantage for this type as compared with the peak instrument, that it was decided to develop the root-mean-square type of instrument. Other considerations were, that with the advances in copper-oxide types of instruments, it has become possible to make root-mean-square instruments of sufficient sensitivity for most purposes without the use of vacuum tubes and their attendant need of power supply, an advantage not shared by peak-reading instruments, at least at present. Thus, the root-mean-square instrument has advantages of comparative low cost, ruggedness, and freedom from the need of power supply, and can, moreover, be readily made in portable forms when desired.

DYNAMIC AND ELECTRICAL CHARACTERISTICS

It will be appreciated from the earlier discussion that for a volume indicator to be truly standard, its dynamic and electrical characteristics must be controlled and specified so that different instruments will read alike on the rapidly varying speech and program waves. Therefore, the next step in the development was to determine suitable values for these characteristics.

In deciding upon the dynamic characteristics, an important factor included in the consideration was the ease of reading the instrument and the lack of eye-strain in observing it for long periods.

First, a number of existing instruments were studied, including some experimental models constructed inde-

pendently for the two broadcast companies prior to the start of this joint development. In this, the opinions of technicians, accustomed to reading volume indicators as a part of their regularly assigned duties, were sought, as well as those of the engineers. The instruments studied included a considerable range of speeds of response and of damping. From this work, the following conclusions were reached:

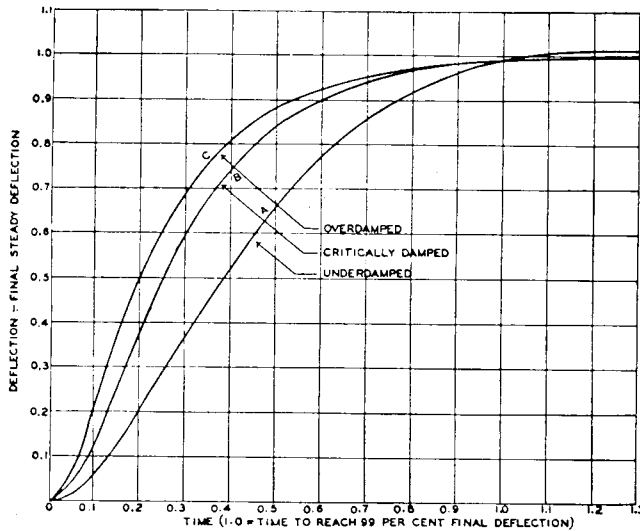

Fig. 10—Effect of damping on instrument characteristics.

(a) For ease of reading and minimum of eye fatigue, the movement should not be too fast. As a result of observations under service conditions and other tests the requirement was adopted that the sudden application of a 1000-cycle sine wave of such amplitude as to give a steady deflection at the scale point where the instrument is to be read, shall cause the pointer to read 99 per cent of the final deflection in 0.3 second.

(b) The movement shall be slightly less than critically damped, so that the pointer will overswing not less than 1 per cent nor more than 1.5 per cent when the above sine wave is suddenly applied.

This last point deserves further discussion. It was noted that on speech or program waves, instruments which were critically damped or slightly overdamped had a more "jittery" action than instruments slightly underdamped, and the strain of reading them was greater. The reason for this will be understood by reference to the theoretical curves shown in Fig. 10. These curves represent, for three different degrees of damping, the deflection versus time following the sudden application of a steady sine wave. Curve A is for a movement underdamped by the amount specified above. Curve B is for a critically damped movement, while curve C is for a movement which is overdamped by the same factor that A is underdamped. It is assumed that the periods of the three movements are so adjusted that all reach a deflection of 99 per cent in the same time and that the sensitivities of each are the same.

It will be noted that the velocity of the pointer in curve A is more nearly uniform than in the other curves, and that the maximum velocity in A is only about half that in C. Because of the lower and more uniform velocity, there will be much less eyestrain in watching pointer A, as it dances about in response to program waves, than either of the others. Moreover, the same curves inverted will equally well represent the motion of the pointers when the applied wave is suddenly stopped. It is evident, by inspection of the region shown near zero, that pointers B and C will start downward very rapidly whereas pointer A will pause for a moment and then start downward more slowly. This is of importance since it is the maximum excursions of the pointer which must be observed in reading volume levels. The tendency to pause at the top of the swing before starting downward makes A easy to read, and the failure to do so explains the observed "jittery" motion of instruments such as B and C.

As a further part of this study, high-speed moving pictures were taken of the available volume indicators, showing their response to suddenly applied sine waves. The pictures were taken at 400 frames a second and included on the edge of each frame was a photograph of a clock device which indicated time in thousandths of a second. From measurements made on these films, the data plotted in Fig. 11 were obtained. It is interesting to observe how lightly damped are the oscillations of the 203C volume indicator, which until the advent of the new instrument has been in use in considerable numbers. The curve for the peak volume indicator on Fig. 11 must not be mistaken for the true speed of

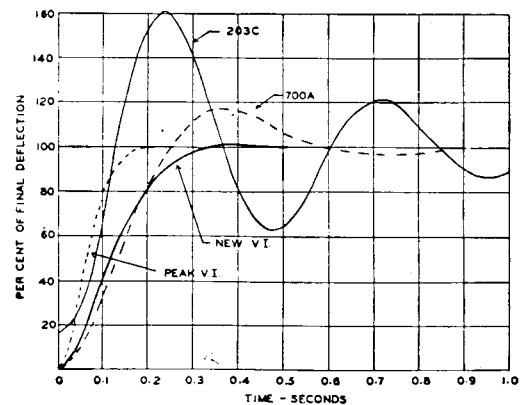

Fig. 11—Deflection of volume indicators to suddenly applied sine wave.

response but is merely the speed with which the instrument reads the charge on the condenser (see Fig. 2). The charge builds up quite rapidly, but the instrument follows in more leisurely fashion as shown. The instrument, as noted earlier, will actually give a reading of 80 per cent on an impulse of sine wave as short as 0.025 second.

The above characteristics were decided upon only after many tests corroborated by field trials under

actual working conditions. The validity of the conclusions reached in the tests of earlier root-mean-square volume indicators was checked with respect to the new instrument by further tests.

The question of whether the rectifier should be half wave or full wave needs little discussion. The oscillogram of the speech wave shown in Fig. 1 shows a very marked lack of symmetry. Evidently if a volume indicator is to give the same reading no matter which way its input is poled, a balanced full-wave rectifier is required.

Throughout this paper, the term "root-mean-square" has been used loosely to describe the general type of instrument under consideration. Some tests were made to determine the actual law of addition of the new volume indicator.

The procedure was based on determining the exponent p in the equation $i = ke^p$ which is equivalent to the actual performance of the instrument for normal deflections. (In the equation i is the instantaneous current in the instrument coil and e is the instantaneous potential applied to the volume indicator.) Two methods were employed. One consisted in determining the ratio of the magnitudes of the sine-wave alternating- and the direct-current potentials which when applied to the volume indicator give the same deflection. The second method consisted in determining the ratio of the single-frequency potential to the potential of each of two equal amplitude, nonharmonically related frequencies which when simultaneously applied give the same deflection.

Without going into the mathematics involved, a number of the new volume indicators were found to have exponents of about 1.2. Therefore, their characteristics are intermediate between linear ($p=1$) and square-law or "root-mean-square" ($p=2$) characteristic. Applying the second method to a Western Electric 1G volume indicator, which is considered to be a "root-mean-square" instrument, the exponent was found to be 1.89.

INSTRUMENT SCALE

Among the more important features to be considered in the development of a volume indicator is the design of its scale. In broadcast studios, volume indicators are under observation almost continuously by the control operators, and the ease and accuracy of reading and the degree of eyestrain are of major importance.

Prior to the adoption of the new standard volume indicator there was a wide variety of volume-level indicator scales in use by the electrical communications industry. This, coupled with the use of a number of different kinds of instruments, reference levels, etc., resulted in considerable confusion when volume measurements were involved.

Volume-level indicators, as already explained, are used (a) as an aid in compressing the wide dynamic range of an original performance to that of the asso-

ciated transmission medium and (b) for locating the upper part of the dynamic range just within the overload point of an equipment during its normal operation. For the first of these uses, a scale having a wide decibel range is preferable. For the latter purpose, a scale length of 10 decibels is usually adequate. Since a given instrument may be used for both applications, neither too large nor too small a range is desirable in a volume-level indicator for the above purposes. A usable scale length covering 20 decibels appears to be a satisfactory compromise.

It is evident that the instrument scale should be easy to read in order that the peak reached by the needle under the impetus of a given impulse may be accurately determined. The instrument scale, therefore, should be as large as practical since, in the case of the broadcast and motion-picture applications, attention is divided between the action in the studio and the volume indicator.

The instrument-scale graduations should convey a meaning, if possible, even to those not technically inclined but who are, nevertheless, concerned with the production of the program material.

Finally, the scale must be properly illuminated so that the relative light intensity on the face of the instrument is comparable to that on the sound stage. Unless this condition prevails, the eye will have difficulty in accommodating itself with sufficient rapidity to the changes in illumination as the technician glances back and forth from the studio to the volume-indicator instrument.

Existing Scales

The volume-indicator scales most commonly employed in the past are shown in Figs. 12, 13, 14, and 15. It is evident that all these scales differ from each other in one or more respects.

The color combinations employed for the scale shown in Fig. 12 and the simplicity of its markings are outstanding virtues. The division markings and the numerals of the main scale are black on a yellow background. The decibel divisions and associated numerals are in red and considerably less conspicuous than the main scale.

However, the 0-to-60 scale, which is used on both of the instruments shown in Figs. 12 and 13, is an arbitrary one bearing no simple relation to the electrical quantity being measured. Because of this, some of the nontechnical persons concerned with program production are prone to request that a certain "effect" which they desired to transmit at a louder-than-normal level, be permitted to swing the indicating needle beyond the normal reference point of "30" on the scale. It is not evident to them from the instrument scale that the normal reading of "30" corresponds to maximum "undistorted" output of the system.

The scale shown in Fig. 14, on the other hand, was primarily intended for steady-state and not volume-

level-measurement purposes. Consequently, this scale has little, if anything, to commend it for program monitoring use. Nevertheless, the simplicity and the fine electrical features of this type of instrument, together with its relatively reasonable cost, has resulted in its general application to volume-indicator service. It is evident, however, that the scale card which con-

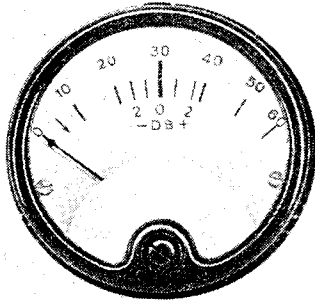

Fig. 12—Scale on 203C volume indicator.

tains all kinds of identification data, is entirely too confusing for quick, accurate observations as the needle swings rapidly back and forth across the scale.

The scale shown in Fig. 15 has the merit of simplicity and easy readability. It is, however, somewhat limited in the decibel range appearing on the scale.

New Scale

Both v_u^5 and markings proportional to voltage are incorporated in the new instrument scale. The need for the former is obvious, but the philosophy which leads to the inclusion of the latter requires an explanation.

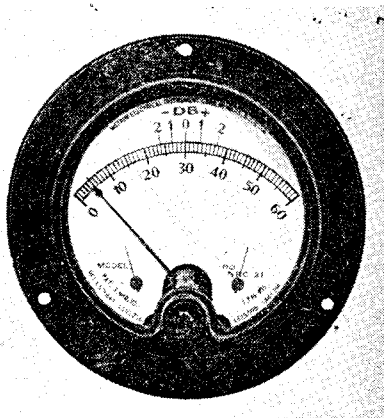

Fig. 13—Scale on type 21 volume indicator.

It is evident, assuming a linear system, that the voltage scale is directly proportional to percentage modulation of a radio transmitter upon which the program is finally impressed. If the system is adjusted for complete modulation for a deflection to the 100

⁵ Defined below.

per cent mark, then subsequent indications show the degree of modulation under actual operating conditions. In the interests of best operation, it may be desirable, of course, to adjust the system for somewhat less than complete modulation when the 100 per cent indication is reached.

In any event, the indications on the voltage scale always show the *percentage utilization of the channel*. This is a decided advantage because everyone involved has a clear conception of a percentage indication. Furthermore, since the scale does not extend beyond the 100 per cent mark (except in the form of a red warning band) and since it is impossible to obtain more than 100 per cent utilization of the facilities, there is no incentive on the part of nontechnical people connected with program origination, to request an extra loud "effect" on special occasions.

Actually, two scales, each containing both v_u and voltage markings, have been devised. One of these known as the type-A scale, Fig. 16, emphasizes the v_u markings and has an inconspicuous voltage scale. The second, known as the type-B, Fig. 17, reverses the emphasis on the two scales. This arrangement permits the installation of the instrument which features the scale that is most important to the user, while retaining the alternate scale for correlation purposes.

The new scale retains the simplicity and the general color scheme of the former Fig. 12 scale. The main divisions markings and the associated numerals are, in each case, in black. The secondary data are smaller (and in one case, are in red) and therefore less conspicuous than the others. All irrelevant markings have been omitted from the scale.

The color of the scale card, which is a deep cream,

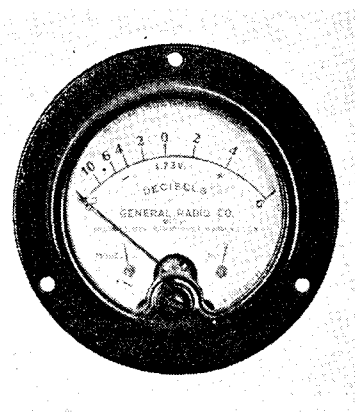

Fig. 14—Scale on type 586 power-level indicator.

seems to be a satisfactory compromise between high contrast and reduced eyestrain and fatigue. This choice is based upon the preference of a large group of skilled observers and upon the reports of certain societies for the improvement of vision. The use of matte-finished instrument cases having fairly high reflection

coefficients, such as light grey, is also desirable for ease of vision.

The location of the "reference" point is such that 71 per cent of the total scale length is utilized as compared to only 42 per cent in former instruments. This feature, combined with the use of a larger sized instrument results in a useful scale more than 2.5 times the length of former scales.

Although the reference point is no longer in the traditional vertical or near-vertical position, it has been found that even those who have long been accustomed to the old arrangement, soon discover the advantages of the new scale. This is attested, in the case of the broadcast application, by the general acceptance of this scale by the personnel of stations located in all sections of the country.

A small but important feature of the new scale is the use of an arc to connect the lower extremities of the vertical black division marks. This arc affords a natural path along which the eye travels as it watches the needle flash up and down the scale. The omission of this arc would result in a number of vertical division marks, hanging in space, as obstacles to the free back-and-forth motion of the eye.

It is evident upon comparison of Figs. 12, 13, 14, and 15 with Figs. 16 and 17 that the dynamic volume range visible on the scale is at least twice as great as on former instruments. This range, as already explained, is a good median value for general use.

Mention was made of the opinions of a group of skilled observers. This group consisted of more than 80 broadcast technicians who, in the performance of

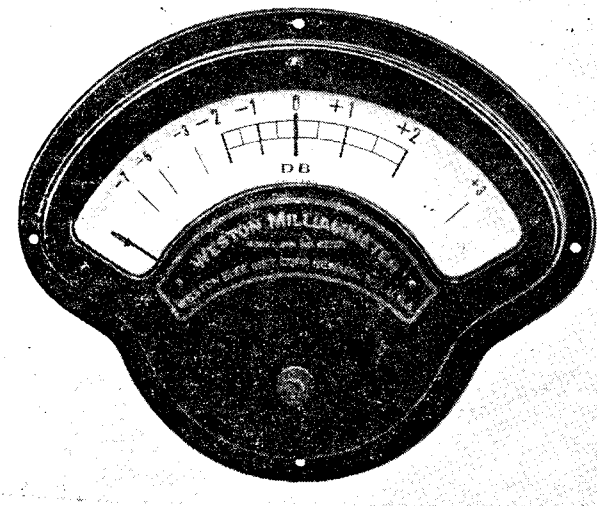

Fig. 15—Type of scale used on 1G and 700A volume indicators.

their duties, watch volume-indicator instruments almost continuously throughout the working day. The opinions of this group were obtained by submitting working models for their individual considerations. It is believed that some of the results of these observations are of interest.

(a) 83 per cent preferred the cream in place of a white scale card.

(b) 90 per cent preferred the "0-100" scale to the "0-60" scale.

(c) 92 per cent preferred the longer scale length (3.5" versus 2.36").

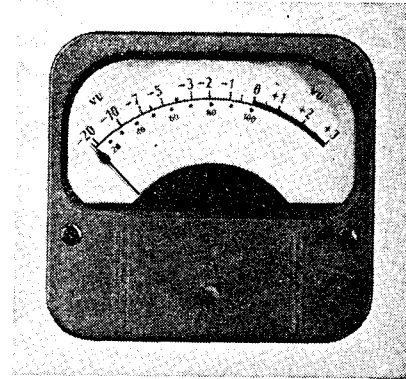

Fig. 16—New volume indicator—A scale.

(d) 97 per cent preferred the numerals placed above the arc.

(e) 50 per cent preferred the spade pointer to the lance type.

(f) 93 per cent agreed on the adequacy of 3-decibel leeway above the reference point.

NEW REFERENCE LEVEL AND TERMINOLOGY

Having agreed on the characteristics of the new standard volume indicator, the interests of complete standardization call for agreement, as well, upon a uniform method of use and a uniform terminology. Agreement upon a uniform method of use must include establishing the reference-volume or zero-vol-

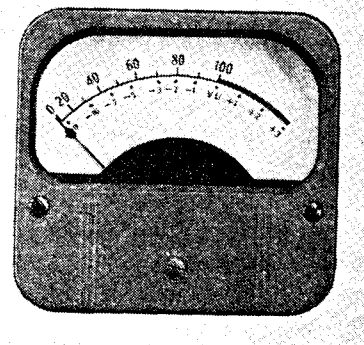

Fig. 17—New volume indicator—B scale.

ume level to which the readings are to be referred and agreeing upon the technique of reading the volume indicator.

It is important to appreciate that "reference volume" is a useful practical concept, but one which is quite arbitrary and not definable in fundamental

terms. For example, it cannot be expressed in any simple way in terms of the ordinary electrical units of power, potential, or current, but is describable only in terms of the electrical and dynamic characteristics of an instrument, its sensitivity as measured by its single-frequency calibration, and the technique of reading it. In other words, a correct definition of reference volume is *that level of program which causes a standard volume indicator, when calibrated and used in the accepted way, to read 0 vu.*⁷

It is especially cautioned that reference volume as applied to program material should not be confused with the single-frequency power used to calibrate the zero volume setting of the volume indicator. If a volume indicator is calibrated so as to read zero on a sine-wave power of, say, 1 milliwatt in a stated impedance, a speech or program wave in the same impedance whose intensity is such as to give a reading of zero will have instantaneous peaks of power which are several times 1 milliwatt and an average power which is only a small fraction of a milliwatt. It is therefore, erroneous to say that reference volume in this case is 1 milliwatt. Only in the case of sine-wave measurements does a reading of 0 vu correspondent to 1 milliwatt.

It should be emphasized that although it is convenient to measure the performance of amplifiers and systems by means of single frequencies there is no exact universal relationship between the single-frequency load-carrying capacity indicated by such measurements, and the load-carrying capacity for speech and program waves expressed in terms of volume level. This relationship depends upon a number of factors such as the rapidity of cutoff at the overload point, the frequency band width being transmitted, the quality of service to be rendered, etc.

It has already been brought out that in the past there have been a multiplicity of reference volumes differing from each other not only because of the various single-frequency calibrations which have been employed, but also because of the dissimilar dynamic characteristics of the different instruments used to measure volume levels. It is also apparent that the introduction of a new volume indicator whose characteristics are not identical with any of its predecessors inherently means the introduction of a new reference volume no matter how it is calibrated. Therefore, there did not seem to be any compelling reason to make the calibration of the new instrument agree with any of the calibrations used in the past. Moreover, to many there seemed to be some advantage in setting the new reference level at a sufficiently different order of magnitude from those which had been in most common use, so that there will be little chance of confusing the new standards with any of those that went before.

After much thought and discussion, it was agreed that the new reference volume should correspond to the reading of the new volume indicator when calibrated with 1 milliwatt in 600 ohms across which the

volume indicator is bridged. Other calibrating values considered were 10^{-16} watt, 6 milliwatts, and 10 milliwatts, in 600 ohms or in 500 ohms. The value chosen was preferred by a majority of a large number of people who were consulted and in addition was found to be the only value to which all could agree. Some of the reasons for choosing 1 milliwatt (10^{-3} watts) were: (a) It is a simple round number, easy to remember; (b) 10^{-3} is a preferred number⁶; (c) 1 milliwatt is a much-used value for testing power for transmission measurements, especially in the telephone plant, so that choice of this value, therefore, permits the volume indicators to be used directly for transmission measurements.

The choice of the standard impedance of 600 ohms was influenced by the fact that, considering all of the plants involved, there is more equipment designed to this impedance than to 500 ohms.

The question may very well be raised why the reference volume has been related to a calibrating *power* rather than to a calibrating *voltage*, inasmuch as a volume indicator is generally a high-impedance, voltage-responsive device. A reference level could conceivably be established based on voltage and the unit of measurement might be termed "volume-volts." However, volume measurements are a part of the general field of transmission measurements, and the same reasons apply here for basing them on power considerations as in the case of ordinary transmission measurements using sine waves. If the fundamental concept were voltage, apparent gains or losses would appear wherever impedance-transforming devices, such as transformers, occur in a circuit. This difficulty is avoided by adopting the power concept, making suitable corrections in the readings when the impedance is other than 600 ohms.

Having chosen the zero point to which the new volume readings would be referred, the next question to be decided was the terminology to be employed in describing the measurements. As has been pointed out, the past custom of describing the volume measurements as so many decibels above or below reference level has been ambiguous because of differences in instruments and standards of calibration. It was thought, therefore, that there would be less confusion in adopting the new standards if a new name were coined for expressing the measurements. The term selected is "vu," the number of vu being numerically the same as the number of decibels above or below the new reference-volume level. It is hoped that in the future *this new term will be restricted to its intended use so that, whenever a volume-level reading is encountered expressed as so many vu, it will be understood that the reading was made with an instrument having the characteristics of the new volume indicator and is expressed with respect to the new reference level.*

⁶ A. Van Dyck, "Preferred numbers," Proc. I.R.E., vol. 24, pp. 159-179; February, (1936).

The procedure for reading the new volume indicator is essentially the same as that which has always been employed, with the exception that, since the instrument is very nearly critically damped, there need be tolerated fewer overswings above the prescribed deflection. One who is familiar with the use of volume indicators will instinctively read the new instrument correctly. The procedure may be described by stating that the adjustable attenuator, which is a part of the volume indicator, should be so adjusted that the extreme deflections of the instrument needle will just reach a scale reading of 0 on the vu scale or 100 on the per cent voltage scale. The volume level is then given by the designations numbered on the attenuator. If, for any reason, the deflections cannot be brought exactly to the 0-vu mark or 100 per cent mark, the reading obtained from the setting of the attenuator may, if desired, be corrected by adding the departure from 0 shown in the vu scale of the instrument.

Since program material is of a very rapidly varying nature, a reading cannot be obtained instantaneously but the volume indicator must be observed for an appreciable period. It is suggested that a period of 1 minute be assumed for program material and 5 to 10 seconds for message telephone speech, so that the volume level at any particular time is determined by the maximum swings of the pointer within that period.

SUMMARY OF CHARACTERISTICS

In the preceding sections of the paper the considerations which led to the selection of the more-important characteristics of the new volume indicator have been discussed in some detail. In this section a summary will be made, first of the fundamental requirements which must be conformed to by any instrument if it is to be a standard volume indicator according to the new standards and second, of other requirements which have been specified for the new volume indicators which are perhaps matters more of an engineering than of a fundamental nature. These requirements are a condensation of the more important features of the specifications for the new instrument. The Weston Electrical Instrument Corporation generously co-operated in the development, but it is emphasized that the specifications are based on fundamental requirements and are not written on the product of a particular manufacturer. The complete requirements are available to any interested party, and, as a matter of fact, at least one other manufacturer has produced an instrument which meets the requirements.

(A) Fundamental Requirements

1. Rectifier

The volume indicator must employ a full-wave rectifier.

2. Scales

The face of the instrument shall have one of the two scale cards shown in Figs. 16 and 17. Both cards shall have a "vu" scale and a "percentage voltage"

scale. The reference point at which it is intended normally to read the instrument is located at about 71 per cent of the full-scale arc. This point is marked 0 on the vu scale and deviations from this point are marked in vu to +3 and to -20. The same point is marked 100 on the other scale which is graduated proportionately to voltage from 0 to 100.

3. Dynamic Characteristics

If a 1000-cycle voltage of such amplitude as to give a steady reading of 100 on the voltage scale is suddenly applied, the pointer should reach 99 in 0.3 second and should then overswing the 100 point by at least 1.0 and not more than 1.5 per cent.

4. Response versus Frequency

The sensitivity of the volume-indicator instrument shall not depart from that at 1000 cycles by more than 0.2 decibel between 35 and 10,000 cycles per second nor more than 0.5 decibel between 25 and 16,000 cycles per second.

5. Calibration

The reading of the volume indicator (complete assembly as shown schematically in Fig. 18) shall be 0 vu when it is connected to a 600-ohm resistance in which is flowing 1 milliwatt of sine-wave power at 1000 cycles per second, or n vu when the calibrating power is n decibels above 1 milliwatt.

(B) Specific Requirements

1. General Type

The volume indicator employs a direct-current instrument with a noncorrosive full-wave copper-oxide rectifier mounted within its case.

2. Impedance

The impedance of the volume indicator arranged for bridging across a line is about 7500 ohms when measured with a sinusoidal voltage sufficient to deflect the pointer to the 0-vu or 100 mark on the scale. Of this impedance 3900 ohms is in the meter and about 3600 ohms must be supplied externally to the meter.

3. Sensitivity

The application of a 1000-cycle potential of 1.228 volts root-mean-square (4 decibels above 1 milliwatt in 600 ohms) to the instrument in series with the proper external resistance causes a deflection to the 0-vu or 100 mark. The instrument, therefore, has sufficient sensitivity to be read at its normal point (0 vu or 100) on a volume level⁷ of +4 vu.

⁷ There should be no confusion because certain instruments deflect to a scale marking of 0 vu when a level of +4 vu is applied to them. As in previous volume indicators, the 0-vu point on the vu scale is merely an arbitrary point at which it is intended nominally to read the instrument, and the rest of the vu scale represents deviations from the 0-vu point. The volume level is read, not from the scale, but from the indications on the associated sensitivity control when the latter is so set as to give a scale deflection to the 0-vu mark. If a deflection other than 0 vu is obtained, the volume level may be corrected by the deviation from 0 vu shown on the instrument scale. In the present art, it is difficult to make an instrument of the desired characteristics having a sensitivity greater than that indicated.

4. Harmonic Distortion

The harmonic distortion introduced in a 600-ohm circuit by bridging the volume indicator across it is less than that equivalent to 0.2 per cent (root-mean-square).

5. Overload

The instrument is capable of withstanding, without injury or effect on calibration, peaks of 10 times the voltage equivalent to a deflection to the 0-vu or 100 mark for 0.5 second and a continuous overload of 5 times the same voltage.

6. Color of Scale

The color of the scale card, expressed according to the Munsell⁸ system of color identification is 2.93 Y (9.18/4.61).

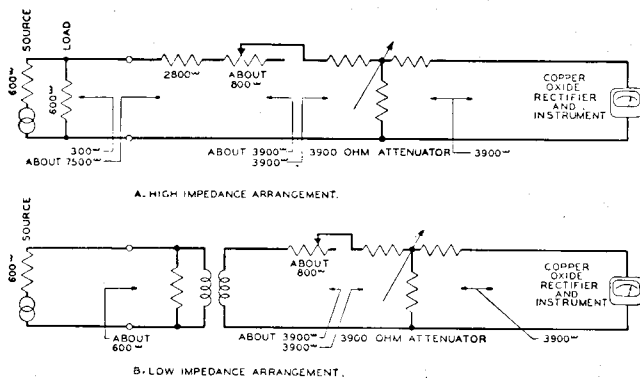

Fig. 18—Circuits for new volume indicator.

7. Presence of Magnetic Material

The presence of magnetic material near the movements of the instruments as now made will affect their calibrations and dynamic characteristics. This is because it has been necessary to employ more powerful magnets than usually required for such instruments to obtain the desired sensitivity and dynamic characteristics, and any diversion of flux to near-by magnetic objects effectively weakens the useful magnetic field beyond the point where these characteristics can be met. The instruments should not, therefore, be mounted on steel panels. (The effect is only slight if they are mounted on 1/16-inch panels with the mounting hole cut away as far as possible without extending beyond the instrument area.)

8. Temperature Effects

In the instruments now available, the deviation of the sensitivity with temperature is less than 0.1 decibel for temperatures between 50 degrees Fahrenheit and 120 degrees Fahrenheit, and is less than 0.5 decibel for temperatures as low as 32 degrees Fahrenheit.

DESCRIPTION OF CIRCUITS

The new instrument by itself does not constitute a complete volume indicator but must have certain

⁸ "Munsell Book of Color," Munsell Color Company, Baltimore, Maryland, (1929).

simple circuits associated with it. Two forms which these circuits may take are illustrated in Fig. 18. One volume indicator may, of course, have both circuits with arrangements to select either by means of a key or switch.

Fig. 18A shows a high-impedance arrangement intended for bridging across lines. As noted above about 3600 ohms of series resistance have been removed from the instrument and must be supplied externally in order to obtain the required ballistic characteristics. This was done in order to provide a point where the impedance is the same in both directions, for the insertion of an adjustable attenuator. A portion of the series resistance is made adjustable as shown by the slide-wire in the diagram. This is for the purpose of facilitating accurate adjustment of the sensitivity to compensate for small differences between instruments and any slight changes which may occur with time. The particular arrangement shown in the diagram has an input impedance of about 7500 ohms and a range of +4 to +26 vu for readings at the 0-vu or 100 mark on the instrument scale.

Fig. 18B shows a low-impedance arrangement in which by adding a transformer the sensitivity has been increased by 10 vu at the expense of decreasing the input impedance to 600 ohms. The circuit is so designed that the impedance facing the instrument is the same as in diagram A, so that the proper dynamic characteristics are obtained. This arrangement, being of low impedance, cannot be bridged across a through

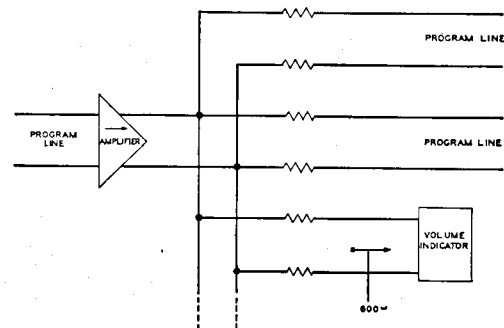

Fig. 19—Program bridge for feeding several lines from one line.

line, but must be used where it can terminate a circuit. It is useful for measuring the transmission loss or gain of a circuit on sine-wave-measuring currents, and also for measurements of volume level where it is connected to a spare outlet of a program bridge circuit, as shown in Fig. 19. Program bridge circuits, one form of which is illustrated in the figure, are commonly employed in the Bell System when it is desired to feed a program from one line simultaneously into a number of other lines. The bridge circuit which is illustrated consists of a network of resistances so designed that the volume level into each of the outgoing lines is the same, that the impedance presented to each is the correct value of 600 ohms, and that the attenuation through the network between any two of the outlets is great.

A picture of a volume indicator which is provided with both of the circuits shown in Fig. 18 is illustrated in Fig. 20.

Fig. 21 shows a group of new standard volume indicators installed in a network key station.

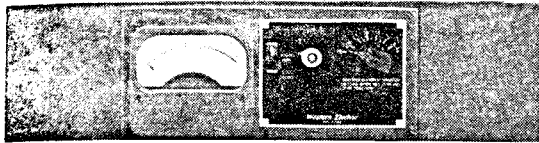

Fig. 20—754B volume indicator equipped with new standard instrument having scale A.

CONCLUSION

This paper has described a new volume indicator which is inexpensive and whose characteristics are thought to represent a good practical compromise for a general-purpose instrument of this kind. It has been commented upon favorably by all who have had any experience with it. It has been adopted as standard by the two largest broadcast companies and the Bell System, and it is hoped that other users of volume indicators will be sufficiently impressed by the merits of the new instrument and by the desirability of standardization in this field to join in its adoption. The new standards are being submitted to the standards committees of the various national organizations for adoption.

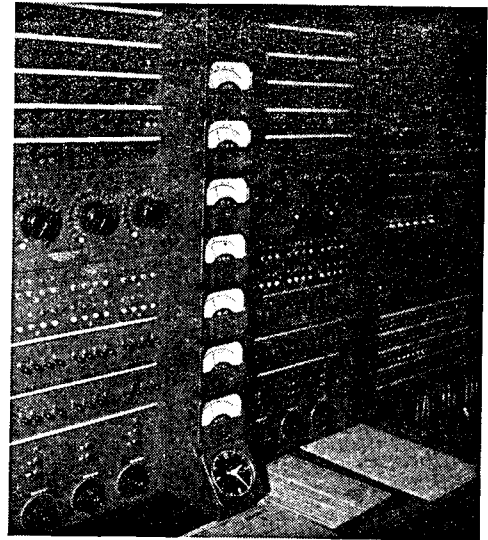

Fig. 21—New standard volume indicators installed at a network key station.

ACKNOWLEDGMENT

Many people contributed to the development which has been described. In particular the authors wish to express their appreciation to Messrs. Robert A. Bradley of the Columbia Broadcasting System, George M. Nixon of the National Broadcasting Company, and S. Brand and Iden Kerney of the Bell Telephone Laboratories, for their important share in the work, and to the Weston Electrical Instrument Corporation for its valued co-operation.