



Miniaturized imaging systems

R. Völkel*, M. Eisner, K.J. Weible

SUSS MicroOptics¹, Neuchâtel, Switzerland

Abstract

Integrated digital micro-cameras are an important feature for next generations of customer products like mobile phones and computers. Key specifications of such micro-cameras are resolution, sensitivity, power consumption, manufacturing and packaging costs—as well as the overall size. Digital micro-cameras used today are rarely smaller than $5 \times 5 \times 5 \text{ mm}^3$. The recent improvements of CMOS image sensors would allow a further miniaturization. However, due to diffraction effects a miniaturization of the optics would drastically reduce resolution and image finesse. How to overcome these limitations of optics? A fascinating approach is to look how nature has successfully solved similar problems in the case of very small creatures. We will explain basic properties of miniaturized imaging systems and show how some of nature's ideas might help to further miniaturize micro-cameras. We will report on microfabrication of refractive microlens arrays, wafer-level packaging and present examples of array imaging systems used for micro-cameras and photolithography applications.

© 2003 Elsevier Science B.V. All rights reserved.

Keywords: Microlens; Fly's eyes; Micro camera; Micro optics; Imaging

1. Optical properties of small-scale lens systems

In the following we will discuss the influence of scale and physical dimensions on the optical properties of image forming systems.

1.1. Aberrations and diffraction limits

The stop number of a lens is given by $F = f/\emptyset$, where f is the focal length and \emptyset is the lens diameter. The diffraction-limited resolution of a lens is given by $\delta x \approx \lambda F$, the depth of focus by $\delta z \approx 4\lambda F^2$ (see Fig. 1). Both values are independent of the lens scale. A downscaling of an imaging

*Corresponding author.

E-mail address: voelkel@suss.ch (R. Völkel).

¹www.suss-microoptics.com.

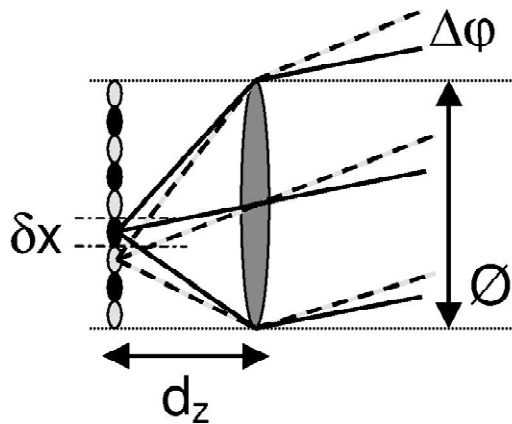

Fig. 1. The diffraction-limited resolution of a lens x is independent of the lens scale. However, downscaling reduces the number of transported image pixels x for a fixed F -number.

system changes the magnitude of the wavefront aberrations, as aberrations are expressed in fractions of the wavelength which remains unchanged. Small lenses have fewer aberrations than large lenses for an equal F -number and wavelength [1]. Aberrations do not have the same weight in micro-optics as they have for macro-optics. For small-scale lens systems, the diffraction limit itself is the important criteria describing and limiting the resolution and image finesse.

1.2. Space-bandwidth product

It was mentioned that a downscaling of a diffraction-limited lens system does not change the size of an image pixel. However, downscaling drastically reduces the number of transported image pixels. For a rough estimation we assume a diffraction-limited lens system that provides a quadratic image field of $I \times I = \phi^2/2$ size. For such an optical system, the number of transported image pixels M is given by:

$$M \approx \frac{I^2}{(\lambda F)^2} = \frac{1}{2} \cdot \frac{\phi^2}{(\lambda F)^2}$$

The number of image pixels M , also referred to as the space-bandwidth product, scales with the square of the lens diameter ϕ for a constant F -number. A miniaturized imaging system is able to image fine details of a scene, but not many. Assuming that the thickness of a lens system is equal to its diameter ϕ , the overall distance from lens-to-image is $d_z = \phi + f = \phi \cdot (1 + F\#)$. Table 1 gives the number of image pixels M for an $F/2.4$ diffraction-limited system of different diameters ϕ .

Table 1
Number of image pixels M for an $F/2.4$ diffraction-limited system of different lens diameters ϕ

Lens diameter	5 mm	2 mm	1 mm	500 μm	200 μm	100 μm
Number of image pixels, M	8,680,556	1,388,889	347,222	86,806	13,889	3,472
Pixels in an image field	2946 \times 2946	1178 \times 1178	589 \times 589	294 \times 294	117 \times 117	58 \times 58
Lens to an image distance, d_z	17 mm	6.8 mm	3.4 mm	17 mm	0.68 mm	0.34 mm

We now better understand why a miniaturization of classical lens systems severely influences the image finesse. In the following we will explain how nature has overcome these fundamental limitations for small animals.

2. Miniaturized imaging systems in nature

Since the Cambrian period about 500 million years ago nature has been exploring and optimizing image-forming systems [2]. For all types of creatures evolution has found appropriate image capturing systems to give them all necessary visual information about their environment.

2.1. Single-aperture eyes

For large vertebrates like humans, eyes are optimized to provide a high resolution, large field of view, focusing ability, color detection and a very large dynamic range to see both in the bright sunshine and in the dark night. Here, the size or volume of the eye is a free parameter for the design. The optical performance is the key issue. Single-aperture eyes—like the human eyes—are similar to photographic or electronic camera systems (see Fig. 3). The eye consists of a flexible lens for focusing, a variable pupil (iris) for fast sensitivity adaptation and the retina, the image detector. The field of vision of a human eye approximates an ellipse about 150° high by about 210° wide. The angular resolution or acuity $\Delta\Phi$ is around 0.6 to 1 min of arc for the fovea. A large single-pupil eye is a perfect solution if miniaturization is not an issue.

2.2. Compound eyes

For small invertebrates having an external skeleton, eyes are very expensive in weight and metabolic energy consume. If the budget is tight, nature prefers to distribute the image capturing to a matrix of some small eye sensors instead of using a single eye. The resolution of such so-called compound or fly's eyes is usually poor compared to the single-aperture eyes [3]. In nature, this lack of resolution is often counterbalanced by additional functionality like a very large view angle, polarization or fast movement detection. Natural eyes are a perfect compromise suited to the requirements of the lifestyle of the animal.

2.3. Apposition and superposition

Compound eyes are multi-aperture optical sensors of insects and crustaceans and generally are divided into two main classes: apposition compound eyes and superposition compound eyes (see Fig. 3). An apposition eye consists of an array of lenses and photoreceptors each of the lenses focusing light from a small solid angle of object space onto a single photoreceptor. Each lens-photoreceptor system is referred to as ommatidia. Apposition eyes have some hundreds up to tens of thousands of these ommatidia packed in non-uniform hexagonal arrays.

The superposition compound eye has primarily evolved on nocturnal insects and deep-water crustaceans. The light from multiple facets combines on the surface of the photoreceptor layer to form a single erect image of the object. Compared to apposition eyes, the superposition eye is much more light sensitive. Some insects use a combination of both types of compound eyes. Variable pigments

switch between apposition (daylight) and superposition (night) or change the number of recruited facets making up the superposition image [4]. A very interesting modification is the neural superposition eye of a housefly, where each ommatidia has seven detector pixels or rhabdomeres. Signals of different adjacent ommatidia interact within the neurons of the fly's brain system. This allows fast directionally selective motion detection, which enables the housefly to maneuver perfectly in three-dimensional space [5].

2.4. Resolution of compound eyes

For a round-shaped apposite compound eye, the observed scene is divided in angular sectors $\Delta\phi$ (see Fig. 3). The angle between the optical axes of two adjacent eyes or ommatidia is referred as the inter-ommatidial angle $\Delta\Phi$. Each eye usually detects only one pixel. The image detection is performed massively parallel. This is a very effective concept for movement detection and large object field observation. A fly almost achieves an observation range of 4π by using two compound eyes on each side of the head.

The key problem of compound eyes is to increase the resolution of a compound eye as a whole, because the eye becomes too big. The diffraction-limited resolution is inversely related to the lens diameter \emptyset . To achieve a higher resolution we have to increase the diameter \emptyset of the eye facets. By doubling the lens diameter \emptyset , the radius of the eye R_{eye} must increase by a factor of four to keep the eye parameter constant.

In conclusion, compound eyes are inherently low-resolution image sensors. For small animals, the limited number of image pixels is the only way to avoid a flooding of the animal's neural system with too much information. However, the low resolution of compound eyes does not allow using this imaging concept within digital micro-cameras.

2.5. Jumping spiders

In contrast to insects, jumping spiders have opted for single-lens eyes, but eight of them (see Fig. 2). Jumping spiders have two high-resolution eyes, two wide-angle eyes and four additional side eyes. The two antero-median eyes provide a magnified image at a high resolution for a rather small visual field [6]. Jumping spiders use these eyes for detailed inspection of objects of interest. It is worth to note that these eyes have a moveable retina. The retina can be moved vertically, laterally and rotationally. The spider can track a prey without moving itself. The two antero-lateral eyes provide a large visual field at a reduced resolution [7]. The small side eyes cover the large field left and right of the spider.

3. Micro-optics

3.1. Micro-optical design

Today's micro-optical design and manufacturing is closely tied to ideas, concepts and technologies developed for semiconductor industry [8,9]. This includes a general restriction to flat building parts (planar lens and receptor arrays), a matrix-oriented patterning (Cartesian coordinates) and pure bulk materials (very limited possibility of index modification). Three main types of microlenses are

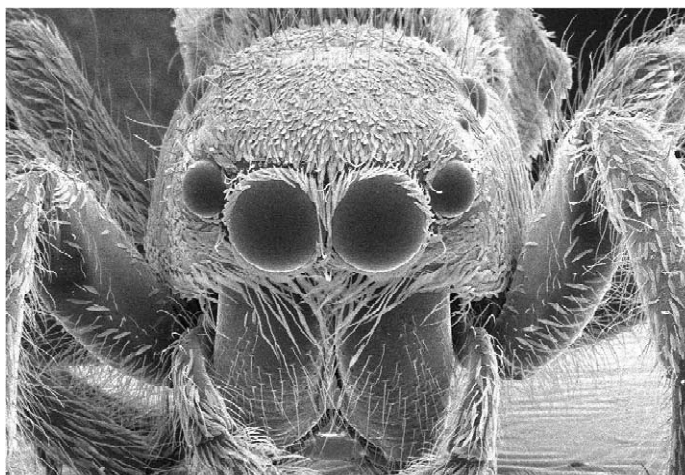

Photograph by Aaron Bell

Fig. 2. SEM picture of the head of a jumping spider. (By courtesy of Aaron Bell, University Hofstra.)

commercially available: diffractive, refractive and graded index microlenses. The separation into different lens types is mainly caused by the limited manufacturing abilities which do not allow implementing diffraction, refraction and index variation of the lens material within the one lens.

3.2. *Microlenses for imaging*

Most animal eyes are based on a combination of curved lens surfaces (see Fig. 3) and a radial symmetric variation of the refractive index within the bulk material [10]. Although such graded index lenses (GRINs) are well suited for imaging tasks, the difficult fabrication process severely limits the assortment of commercially available graded index lenses.

Diffractive microlenses are generally not well suited for imaging tasks. Focal length and efficiency depend strongly on the wavelength of the light and limit the lenses to monochromatic applications. In addition, a finite angular field diameter, low numerical apertures, straylight and ghost images created by spurious diffraction orders will limit their ability for imaging. Nature has never used a diffractive lens for imaging (as far as the authors know).

The most promising manufacturing technique for refractive microlens arrays is the reflow or melting resist technique [11–13]. Photoresist is micro-structured by photolithography and melted. The lens profile is formed by surface tension during the melting (see Fig. 4). The melted resist lens serves as a master for subsequent transfer processes like reactive ion etching or replication in plastic. Aspheric lens profiles are obtained by varying the etch parameters during the reactive ion etching transfer.

3.3. *Apertures and filters*

Apertures, stops, baffles and filters are essential parts of every optical system. They are used to improve the image contrast by blocking aberrant rays, adapting the wavelength spectra and reducing straylight. For miniaturized imaging systems, structured wavelength filters (IR or color filters) and

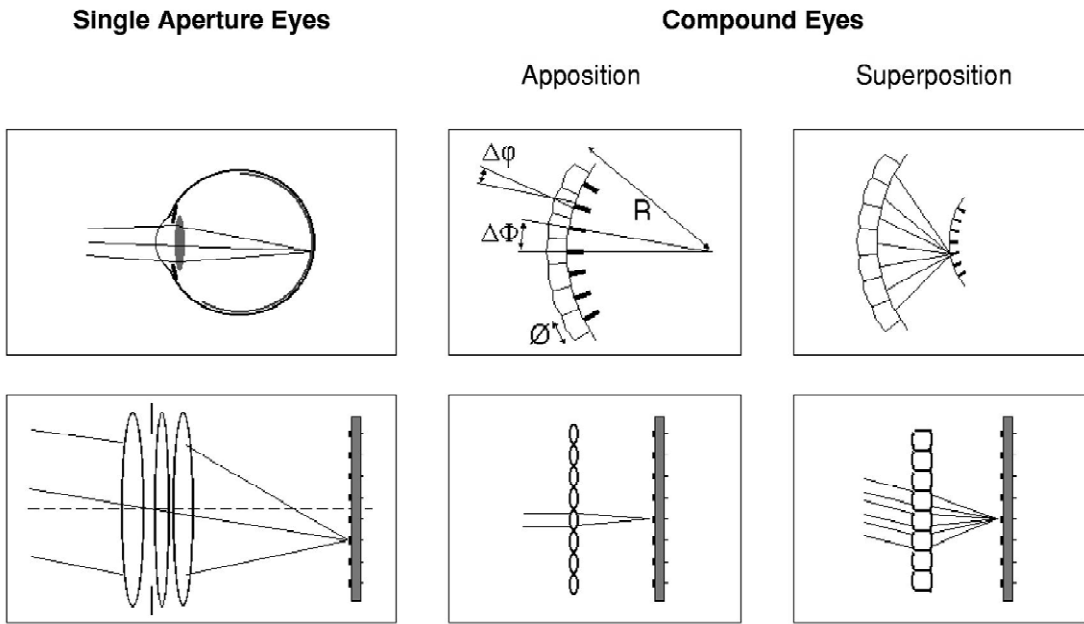

Fig. 3. Different types of natural eye sensors and its technical counterpart.

aperture arrays are realized by thin film deposition, photolithography and consequent etch or lift-off steps.

3.4. Wafer-level packaging of micro-optics

Packaging and alignment of miniaturized lens systems is a rather difficult task. Every micro-optical component has to be aligned according to three lateral and three rotational degrees of freedom. For micro-optics, standard “classical” mounting is not practical and too expensive. The preferred solution is manufacturing of microlenses on a wafer-scale and a wafer-level packaging approach for mounting [14]. A mask aligner is used to align a stack of planar wafers containing both image sensors and optics. The different layers are bonded together by using, e.g., UV-curing epoxy, thermal and fusion

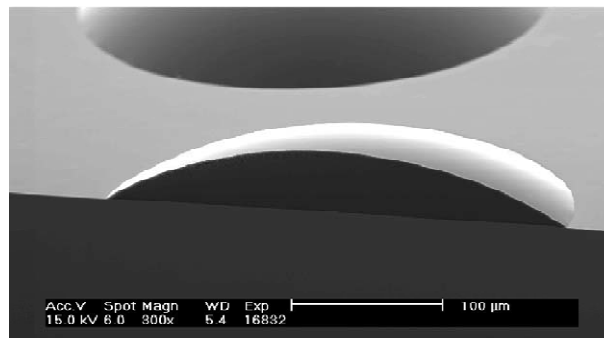

Fig. 4. Refractive microlens fabricated by melting resists technology. (By courtesy of J.-C. Roulet, University of Neuchatel.)

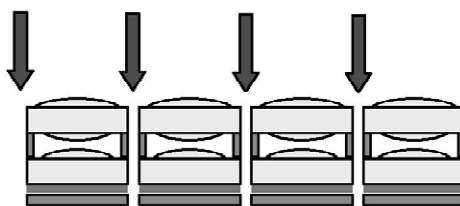

Fig. 5. Wafer-level packaging of optical and electronic layers. A later dicing step is used to separate the wafer into the individual systems or modules.

bonding or thick-film solder glass bonding. A subsequent dicing step is used to separate the wafer stack into the individual systems or modules (see Fig. 5). This method allows a cost-efficient mounting of some hundreds of micro-cameras in one step.

4. Natural design strategies for micro-cameras

In most applications humans have to inspect the resulting micro-camera images. Therefore, the image finesse must be sufficient for humans to identify the observed object or scene. In addition, micro-cameras should have optional wide-angle observation ability. Based on the prior considerations, we derive the following design strategy for image capturing micro-cameras.

(1) The first step for the design is to choose the F -number on the basis of the detector resolution, the desired light gathering ability and the speed of the available optical sub-components.

(2) The next step is to derive the maximum lens diameter \varnothing of the system from the desired overall thickness of the camera system. For an $F/2.4$ system, the image distance is 2.4-times the aperture diameter. The overall thickness is the image distance plus lens and detector thickness.

(3) Knowing lens diameter \varnothing and F /number, the maximum number of transferred pixels M is derived as described above. If the number of image pixels (or angular field) of one single imaging channel is not sufficient for the envisaged application, multiple channels have to be used. Each imaging channel should image only a limited angular section (see Fig. 6). Elliptical lens bases (see Fig. 7) might be used to correct astigmatism for oblique incidence. A superposition of the partial images is performed either within the signal-processing unit (neural superposition) or by spatial superposition in the image plane (see Fig. 6). For spatial superposition, erect imaging is required. Only next neighbor images should superimpose to limit off-axis aberrations.

(4) The resolution of the imaging system should be higher in the center and lower at the rim to provide both, telephoto and wide-angle characteristics.

If we look for examples in nature, we find that the proposed lens design has very much in common with the eyes of jumping spiders. Jumping spiders do not have compound eyes. Their resolution would be too poor to identify a target worth to jump on. To have single-lens eyes as vertebrates, spiders are too small. The spider uses a cluster of single-lens eyes, each pair tailored for a different task. Spiders see almost as sharp as we do and have a good idea what is going on in its surroundings. The natural design concept to distribute the imaging task to an array of different single-lens eyes is the most promising approach for very small micro-camera systems.

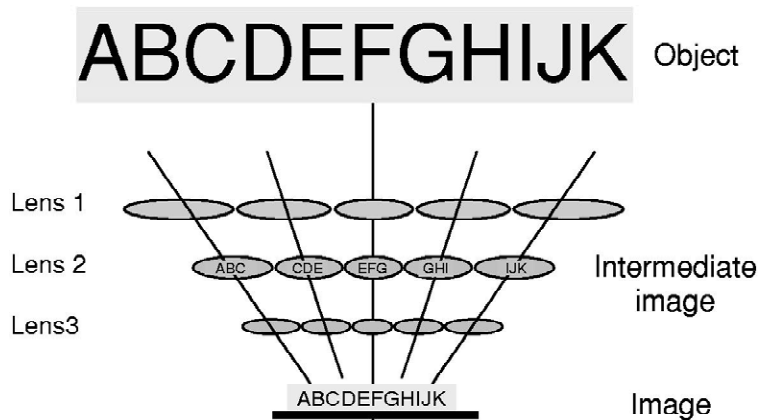

Fig. 6. Miniaturized imaging systems based on spatial superposition of the partial erect images created by adjacent imaging channels. Each imaging channel images only a limited angular section.

5. Miniaturized imaging systems

5.1. Wafer level optics for CMOS imagers

Miniaturized imaging systems based on above design rules and multiple imaging channels are currently investigated [15,16]. Spatial superposition of the partial images created by adjacent imaging channels seems to be the most promising approach. Each imaging channel images only a limited angular section. Elliptical lens bases are used to correct astigmatism for oblique incidence of the light onto the plano-convex microlenses. Wafer-scale lens manufacturing and wafer-level packaging are the key objectives for this approach (see Fig. 8).

5.2. Microlens projection lithography

Microlens projection lithography is a contactless photolithographic technique that has been developed for SUSS mask aligners [17,18]. Microlens projection lithography uses an ultra-flat

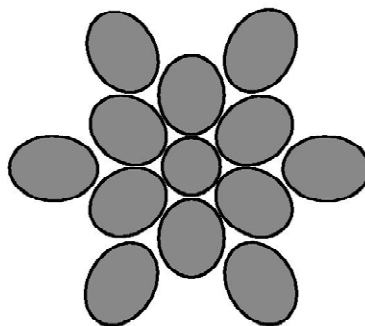

Fig. 7. Lens arrangements for the system shown in Fig. 6. Elliptical lens bases are used to correct astigmatism for oblique incidence.

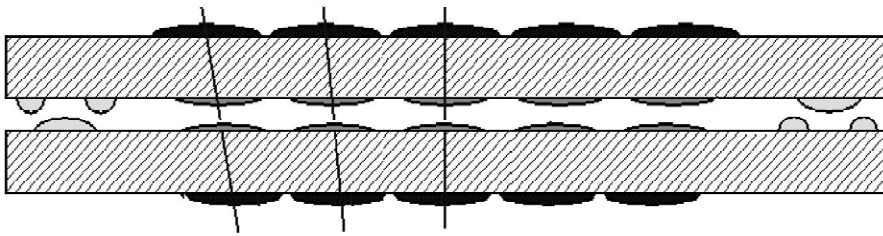

Fig. 8. Wafer-scale lens manufacturing and wafer-level packaging for imaging system.

microlens-based projection system consisting of some 100,000 identical micro-objectives side-by-side. Each micro-objective consists of four microlens layers (see Fig. 9). Wafer-level packaging of the different optical layers ensures a precise alignment of the projection system. Fig. 10 shows the ultra-flat projection system within a SUSS MA150-MPL mask aligner. A fully symmetrical optical design eliminates coma, distortion and lateral color. The lens system is front- and backside telecentric to provide a unit magnification ($+1$) over the whole depth of focus (Fig. 11). Each micro-objective images a small part of the photomask pattern onto the wafer. The partial images from different channels overlap consistently and form a complete aerial image of the photomask. Microlens projection lithography provides a working distance (system-to-substrate) of $WD = 0.8$ mm and a depth of focus, $DOF > 50$ μm for a resolution of 5 μm . Due to the extended DOF and the telecentricity

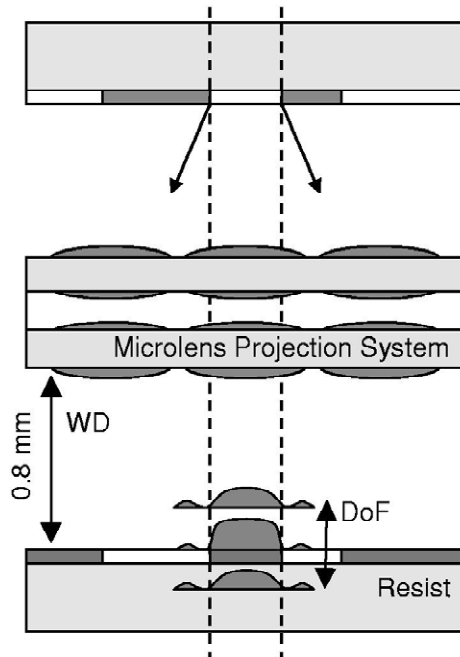

Fig. 9. Microlens projection lithography. An ultra-flat microlens array based projection system is used to project a photomask onto a resist layer. Each micro-objective images a small part of the photomask pattern onto the wafer. The partial images overlap consistently and form a complete aerial image of the photomask. Microlens projection lithography allows photolithography on curved or non-planar substrates, in V-grooves, and holes using an SUSS mask aligner.

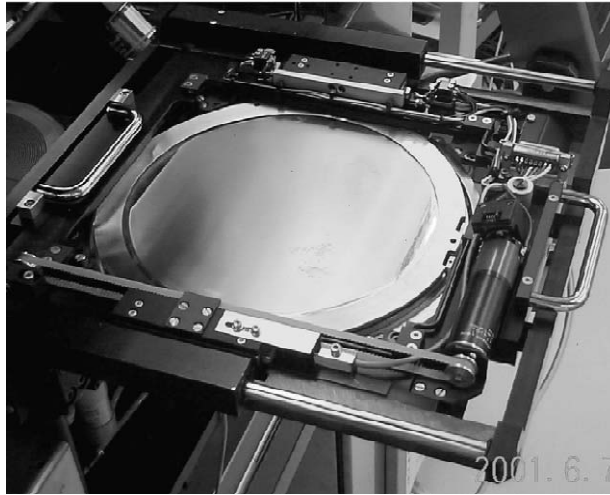

Fig. 10. Ultra-flat projection system integrated into the SUSS MA150-MPLA mask aligner.

microlens projection lithography allows photolithography on curved or non-planar substrates, in V-grooves, and holes.

5.3. *Microlens-based imaging systems for optical networking*

Microlens-based imaging systems are widely used for optical networking. An array of single-mode fibers is collimated by a microlens array (see Fig. 12) (courtesy of Euromicron, Mittenaar, Germany). The collimated beam is focused onto an array of moveable micro-mirrors (MOEMS), a receiver array or another single-mode fiber array. Typical applications are fiber connectors or switches. For single-mode fiber array imaging the core of the sender and receiver fibers represent the object and image pixels. The fundamental limitation of such systems is again the diffraction at the border of the lens which limits the packaging density of fibers and mirrors. For larger fiber-to-fiber distances, the lens diameter has to be significantly increased to transport the light efficiently from sender to receiver fiber.

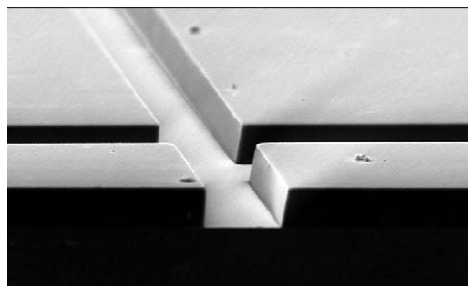

Fig. 11. Print in thick photoresist using an SUSS MA150-MPL mask aligner. Front- and backside telecentricity provides a unit magnification over the whole depth of focus.

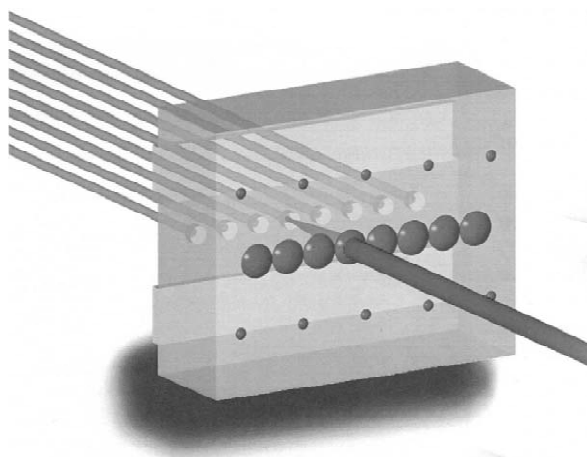

Fig. 12. An array of single-mode fibers is collimated by a microlens array. Microlens arrays are widely used for fiber connectors and switches in optical networking. (By courtesy of Euromicon, Germany.)

6. Conclusion

Miniaturization strategies that have been applied with great success to electronics can not be simply transferred to optical imaging systems. The reason for this is that the diffraction limited spot size of an imaging system does not scale with the actual system dimensions. As a consequence highly miniaturized imaging systems transmit only a small number of image pixels and are useless for most applications. For micro-cameras with standard image formats like VGA or CIF the size of the imaging system is rarely found to be smaller than $5 \times 5 \times 5 \text{ mm}^3$ and remains bulky in relation to the detector chip. A possible way out of this dilemma is to use bio-inspired array imaging systems on the base of microlens array technology. Here the most promising approach is a kind of cluster camera, a combination of single lens systems forming a complete image by spatial or electronic superposition. Miniaturized imaging systems based on similar concepts are under investigation for different applications in electronic imaging and photolithography; however there is still a long way before a “real” micro camera can be integrated into a credit card.

References

- [1] A.W. Lohmann, Scaling laws for lens systems, *Appl. Opt.* 28 (1989) 4996–4998.
- [2] M.F. Land, The optics of animal eyes, *Contemp. Phys.* 29 (5) (1988) 435–455.
- [3] J.S. Sanders, Selected papers on natural and artificial compound eye sensors, in: *SPIE Milestone Series*, Vol. 122, 1996.
- [4] A.W. Snyder, Acuity of compound eyes: physical limitations and design, *J. Comp. Physiol. A* 116 (1977) 161–182.
- [5] N. Franceschini, A. Riehle, A. Le Nestour, Directionally selective motion detection by insect neurons, in: D.G. Stavenga, R. Hardie (Eds.), *Facets of Vision*, Springer Verlag, Berlin, 1989, pp. 360–390.
- [6] M.F. Land, Structure of the retinae of the principal eyes of jumping spiders, *J. Exp. Biol.* 51 (1969) 443–470.
- [7] D.S. Williams, P. McIntyre, The principal eyes of a jumping spider have a telephoto component, *Nature (London)* 288 (1980) 578.
- [8] K. Iga, Y. Kokubun, M. Oikawa, *Fundamentals of Microoptics*, Academic Press/Ohm, New York, 1984.

- [9] H.P. Herzig (Ed.), *Micro-Optics*, Taylor & Francis, 1997.
- [10] K. Iga, S. Hata, Y. Kato, H. Fukuyo, Image transmission by an optical system with a lens-like medium, *Jpn. J. Appl. Phys.* 13 (1974) 79–86.
- [11] Z.D. Popovic, R.A. Sprague, G.A. Neville-Connell, Technique for monolithic fabrication of microlens arrays, *Appl. Opt.* 27 (1988) 1281.
- [12] D. Daly, R.F. Stevens, M. C. Hutley, N. Davies, The manufacture of microlenses by melting photoresist, *J. Meas. Sci. Technol.* 1 (1990) 759–766.
- [13] S. Haselbeck, H. Schreiber, J. Schwider, N. Streibl, Microlenses fabricated by melting photoresist, *Opt. Eng.* 6 (1993) 1322–1324.
- [14] K. Iga, M. Oikawa, S. Misawa, J. Banno, Y. Kokubun, Stacked planar optics: an application of the planar microlens, *Appl. Opt.* 21 (19) (1982) 3456–3460.
- [15] R. Völkel, S. Wallstab, Flachbauendes bilderfassungssystem, German Pat. Offenlegungsschrift DE 199 17 890 A1 (1999).
- [16] European Commission, Project No. IST-2001-34646, WALORI—Wafer Level Optic solution foR compact CMOS Imager, 2002–2005.
- [17] W.B. Hogle, R. Dändliker, H.P. Herzig, Lens array photolithography, GB Pat. Appl. 9224080.3 (1992), US Pat. 08/114,732 (1993).
- [18] R. Dändliker, S. Gray, F. Clube, H.P. Herzig, R. Völkel, Non-conventional fabrication methods for photolithography, *Microelectron. Eng.* 27 (1995) 205–211.