

**CHAPTER RN
REINING HORSE DIVISION**

SUBCHAPTER RN-1 JUDGING.

RN101 General.

RN102 Equipment.

RN103 Scoring.

RN104 Categories of Competition and Class Eligibility.

RN105 Non Pro Conditions.

RN106 Freestyle Reining.

SUBCHAPTER RN-2 PATTERNS.

RN107





CHAPTER RN REINING HORSE DIVISION

For further information regarding the conduct of Reining Horse competitions, contact the National Reining Horse Association (NRHA), 3000 NW 10th St, Oklahoma City, OK 73107-5302; (405) 946-7400 phone; (405) 946-8410 fax.

SUBCHAPTER RN-1 JUDGING.

RN101 General.

1. To rein a horse is not only to guide him, but also to control his every movement. The best reined horse should be willingly guided or controlled with little or no apparent resistance and dictated to completely. Any movement on his own must be considered a lack of control. All deviations from the exact written pattern must be considered a lack of or temporary loss of control and therefore a fault that must be marked down according to severity of deviation. After deducting all faults, set here within, against execution of the pattern and the horse's overall performance, credit should be given for smoothness, finesse, attitude, quickness and authority of performing various maneuvers, while using controlled speed which raises the difficulty level and makes him more exciting and pleasing to watch to an audience. The official guideline for the application for the rules for judging shall be as specified in the NRHA Judges Guide.
2. When copying is available, posting judges scores sheets is mandatory for NRHA approved classes. Score sheets should be posted within one hour of class completion. In the event copies are not an option, judges score sheets must be available for supervised inspection. Original judges score sheets must be returned to the NRHA office with competition results.
3. A reining will be complete and the posted scores will be considered "official" thirty minutes following the last run of the day. Scores must be posted or made available to exhibitors as soon as possible. Score corrections may not be made at any time after the judge has left the grounds.
4. All entries in a class must be drawn for position and must run as drawn. All entries must have a correct exhibitor number displayed. If a rider rides more than one horse, there should be a spread of at least two horses between his/her runs. If an entrant misses his/her turn as determined by the draw, he/she will be disqualified from that go round (except for cases where unusual and truly unavoidable circumstances exist). Each case will be judged on its own merit by the judge(s).
5. Substitution of riders will not be permitted except by agreement of the competition management and in case of injury.
6. A rider may not show more than three (3) horses in a class. (Exception: Arabian, see AR201; Morgan, see MO176.4) A horse may be entered only once per class. In the instance where classes are run concurrently a rider may show three horses per class and a horse may only be shown once.
7. All horses must be ridden astride.
8. It is mandatory for all riders to use appropriate western tack and western attire while showing: this would include a long sleeve shirt, western hat or protective headgear, boots, western saddle and western bridle. (Freestyle reining being exempt based on conditions). Failure to use appropriate attire will result in a score of zero.
9. For purposes of competition in the Reining Division: An individual is eligible to compete as a Junior from January 1 until the end of the calendar year in which they reach the age of 18.

RN102 Equipment.

1. All bits must be free of mechanical device.
2. References to hackamore mean the use of a flexible, braided, rawhide, leather, or rope bosal, the core of which may be either rawhide or flexible cable with a maximum diameter of 3/4" at the cheek. Absolutely no rigid material will be permitted under the jaws, or on the noseband in connection with the bosal, regardless of how padded or covered. Horsehair bosals are prohibited. This rule does not refer to the so-called mechanical hackamore which is illegal.
3. References to snaffle bits mean conventional O-ring, egg-butt, or D-ring with a ring no larger than 4" and no smaller than 2". The inside circumference of the ring must be free of

rein, curb or headstall attachments which would provide leverage. The mouthpiece should be round, oval or egg-shaped, smooth and free of wire. It may be inlaid, but smooth and/or latex wrapped. The bars must be a minimum of 5/16" in diameter, measured 1" in from the cheek with a gradual decrease to center of the snaffle. Optional curb strap is acceptable however curb chains are not acceptable. These requirements remain the same for all classes in which a rider may use a snaffle bit.

4. References to a bit means the use of a curb bit that has a solid or broken mouthpiece, has shanks and acts with leverage. All curb bits must be free of mechanical device and should be considered a standard Western bit. A standard Western bit includes:
 - a. 8 1/2" maximum length shank to be measured as indicated in the NRHA Handbook. Shanks may be fixed or loose.
 - b. Concerning mouthpieces, bars must be round, oval or egg-shaped, smooth and unwrapped metal of 5/16" to 3/4" in diameter, measured 1" from the cheek. They may be inlaid, but must be smooth or latex wrapped. Nothing may protrude more than 1/8 inch below the mouthpiece (bar).
 - c. The port must be no higher than 3 1/2" maximum, with rollers and covers acceptable. Broken mouthpieces, half-breeds, and spades are standard.
 - d. Slip or gag bits, donuts or flat polo mouthpieces are not acceptable.
5. Except for Snaffle Bit and Freestyle Classes, only one hand may be used on the reins, and the hand must not be changed. The hand is to be around the reins; index finger only between split reins is permitted. Violation of this rule results in a penalty score of zero (0).
6. When a curb bit is used, a curb strap or curb chain is required and must be at least 1/2" in width, lie flat against the jaw, and be free of bars, wire, and/or twists.

RN103 Scoring.

1. The scoring will be on a basis of 0-Infinity, with 70 denoting an average performance. Scores will be announced after each horse works. The individual maneuvers are scored in 1/2 point increments from a low of -1 1/2 to a high of +1 1/2 with a score of 0 denoting a maneuver that is correct with no degree of difficulty. Scores will be announced after each horse works.
2. All ties for 1st place will be worked off if the tied exhibitors agree to participate in a run-off. Tied exhibitors have the alternate option of agreeing not to run-off and to be named co-champions but must determine the winner of the awards by a flip of a coin. If they do not agree, the exhibitor(s) who does not want to run-off will forfeit first place to the other. (Exceptions: Freestyle reining - see Freestyle Reining conditions to determine winner or co-champions.
 - a. if a tie occurs after the run-off, the entrants will be named co-champions; will evenly split 1st and 2nd prize money, but must determine the winner of the awards by a flip of a coin. A horse not returning for a run-off without such an agreement will forfeit 1st place prize money regardless of the added money. In the case of a run-off, the contestant(s) not winning the run-off cannot be placed lower than the lowest position for which he/she was tied, i.e., 2nd/3rd. All other ties are not worked off and will involve as many places as there are horses tied, i.e., 4th, 5th, 6th, 7th. The prize money in the previously mentioned example is added together and split equally-four ways.
3. The following will result in result in no score:
 - a. abuse of animal in competition arena and/or evidence that an act of abuse has occurred prior to or during the exhibition of a horse in competition;
 - b. use of illegal equipment, including wire on bits, bosals or curb chains;
 - c. use of illegal bits, bosals or curb chains;
 - d. use of tack collars, tie downs or nose bands;
 - e. use of whips or bats;
 - f. use of any attachment which alters the movement of or circulation to the tail;
 - g. failure to dismount and/or present horse and equipment to the appropriate judge for inspection;
 - h. disrespect or misconduct by the exhibitor
 - i. infraction of any state or federal law which exists pertaining to the exhibition, care and custody of horses within the state or country where an NRHA reining is being held.
 - j. The judge(s) may excuse a horse at any time while in the arena for unsafe conditions or improper exhibition pertaining to either the horse and/or rider.

- k. closed reins are not allowed except as standard romal reins and mecates on snaffle bits and bosals in classes where the use of two hands is allowed.
4. Excess rein may be straightened at any place a horse is allowed to be completely stopped during a pattern. When using a romal the rider's hand shall be around the reins with the wrist kept straight and relaxed, the thumb on top and the hand closed around the reins; no fingers between the reins are allowed. The free hand may be used to hold the romal, provided it is held in a relaxed position and there is at least 16" from free hand to the reining hand. Use of the free hand while holding the romal, to alter the tension or length of the reins from the bridle to the reining hand, is considered to be use of two hands, and a score of 0 will be applied, with the exception of any place a horse is allowed to be completely stopped during a pattern.
5. The following will result in a score of 0:
- a. use of more than index or first finger between reins;
 - b. use of two hands (exception: snaffle bit or hackamore classes designated for two hands) or changing hands;
 - c. use of romal other than as outlined in #4;
 - d. failure to complete pattern as written;
 - e. performing the maneuvers other than in specified order;
 - f. the inclusion of maneuvers not specified, including but not limited to
 - (1) backing more than two strides
 - (2) turning more than 90 degrees (Exception: a complete stop in the 1st quarter of a circle after a canter departure is not to be considered an inclusion of maneuver; a 2 point break of gait penalty will apply.
 - (3) On run in patterns, once beginning a canter a complete stop prior to reaching the first marker.
 - g. equipment failure that delays completion of pattern, including dropping a rein that contacts the ground while the horse is in motion;
 - h. balking or refusal of command where performance is delayed
 - i. running away or failing to guide where it becomes impossible to discern whether the entry is on pattern;
 - j. jogging in excess of one-half circle or one-half the length of the arena while starting a circle, circling or exiting a rollback;
 - k. overspins of more than 1/4 turn;
 - l. fall to the ground by horse or rider. A horse is deemed to have fallen when its shoulder and/or hip and/or underline touches the ground.
 - m. Dropping a rein that contacts the ground while the horse is in motion.
 - n. failure to wear appropriate western attire as outlined in the NRHA Handbook. Western attire may include protective headgear (ASTM/SEI). See GR801.4 and RN101.8.

NOTE: Neither a "no score" nor a 0 is eligible to place in a go round or single go round class. Neither a no score nor a 0 may advance in a multi-go event. In multi go events, finals qualifying horses that get a 0 or a scratch will still be eligible for payouts, with a 0 placing higher than a scratch. In the event not enough horses qualify for total purse distribution, the undistributed portion of the purse will be retained by competition management.

6. The following will result in a \$25 fine, payable to the show organizer.
- a. Failure to have correct exhibitor number displayed
7. The following will result in a five-point penalty:
- a. spurring in front of cinch.
 - b. use of either hand to instill fear or praise.
 - c. holding saddle with either hand.
 - d. blatant disobedience including kicking, biting, bucking, rearing and striking.
8. The following will result in a two-point penalty:
- a. Break of gait.
 - b. Freezing up in spins or rollbacks.
 - c. On walk-in patterns, cantering prior to reaching the center of the arena and/or failure to stop or walk before executing a canter departure.
 - d. On run-in patterns, failure to be in a canter prior to reaching the first marker or break of gait prior to the first marker.

- e. If a horse does not completely pass the specified marker before initiating a stop position.
9. Starting or performing circles or eights out of lead will be judged as follows:
- Each time a horse is out of lead, a judge is required to penalize by 1 point. The penalty for being out of lead is accumulative, and the judge will add 1 penalty point for each 1/4 of the circumference of a circle or any part thereof that a horse is out of lead. A delayed change of lead is a one (1) point penalty from one stride to 1/4 of circumference of a circle and is also cumulative beyond that point.
 - A judge is required to penalize a horse 1/2 of a point for a delayed change of lead by 1 stride where the lead change is required by the pattern description.
10. Deduct 1/2 point for starting circle at a jog or exiting rollbacks at a jog up to 2 strides. Jogging beyond 2 strides but less than 1/2 circle or 1/2 the length of the arena, deduct 2 points.
11. Deduct one-half (1/2) point for over or under spinning up to one-eighth (1/8) of a turn; deduct one (1) point for over or under spinning up to one-quarter (1/4) of a turn.
12. In patterns requiring a run-around, failure to be on the correct lead when rounding the end of the arena will be penalized as follows: For 1/2 the turn or less, 1 point; for more than 1/2 the turn, 2 points.
13. There will be a half point penalty for failure to remain a minimum of 20 feet from the side of the arena when approaching a stop and/or rollback.
14. Judges may not confer as to any penalty or maneuver score prior to submitting a score. If a major penalty (a penalty which results in a no score, a 0, or a 5 point penalty) is unclear, a judge will submit his/her score and ask that the score be held, pending a conference and/or review of the official video at the earliest appropriate time. Should the judges determine via conference or official video replay that a penalty was incurred, it should be applied. If, however, no penalty occurred, the score will be announced as originally submitted. No judge shall be required to change his/her score following a conference or official video replay. Each judge's decision is an individual call and based on individual decision from a conference or official video replay. The use of official video equipment by the judges is only permissible if the judge has reason to believe that all entries have been videotaped.
15. The judge shall have the authority to remove any contestant from a competition he is judging, should said contestant show any disrespect or misconduct as to render himself or the competition in an unprofessional manner.
16. All riders must dismount. The horse must be presented and the bridle dropped by the rider or a designated representative. The horse and equipment must be checked by the designated judge or steward in the arena or in close proximity to the arena during a pre- or post-check. Should the equipment judge detect cause for a no score, the exhibitor or his/her representative, trainer, or guardian may at that time accept the no score and allow the equipment judge to cause the appropriate changes to all score cards or request the other judges confer on the appropriate call. In the case of a youth exhibitor, should a parent, trainer, or guardian not be present, it will be assumed that all parties are aware of this rule and agree to abide by the exhibitor's decision. If requested, the equipment judge will confer with the other judges as soon as practical. Failure to comply with this rule will result in a no score.
17. Judges shall be the sole person responsible to determine if a rider has correctly completed the pattern as written.
18. NRHA permits the judge the option of awarding a re-ride to any contestant who, in the judge's opinion, is unable to complete a pattern for reasons that are out of the rider's control. In the instance where a re-ride is warranted in the judge's opinion, the judge should advise the NRHA Representative and/or Competition Management of such as soon as is possible.
19. An exhibitor or owner in the respective class may request a review of a major penalty applied to a run (penalty score of 0 and 5 point penalty). The judge(s) has the right to deny or honor the request. If honored by the judge(s) he/she must believe the entire class was videotaped by an official videographer. The request must be made no later than 30 minutes after the last run of the day, and before the judge(s) has left the grounds for the day. In cases where a class is run in sections over multiple days, each day's scores will be official thirty minutes after the last run of each section. Exhibitors or owners may not have direct contact with the judge(s) during the entire process of requesting a review. The request

must be submitted to the Competition Steward, Competition Representative, or if need be Competition Management who will take the request to the judge(s).

20. For regulations concerning showing under judges, refer to GR1304.

RN104 Categories of Competition and Class Eligibility.

Class eligibility is based on the rider's and/or the horse's earnings as of January 1 of the current NRHA year. It is the responsibility of the owner and/or rider to be aware of the official earnings of the horse and/or rider as recorded by NRHA. When limits of eligibility are surpassed during the competition year, the exhibitor can complete the year in that specific class or division. Any rider participating in a class or division in which he/she (or the horse he/she is riding) is not eligible will be placed on probation for 30 days for the first offense. Second and subsequent offenses will result in a 30-day suspension and a fine of \$200. When a horse/rider is found to be ineligible, the earnings will be forfeited to the NRHA. NRHA will make corrections to the class placing and earnings in the database. It is the responsibility of the ineligible exhibitor to return all forfeited earnings to the NRHA and all prizes and awards to the Competition Secretary. Earnings in Categories 3, 4, 5, 6, 7 and 8 will be reflected on horse and rider lifetime earnings and will be used for determining eligibility status for the Rookie class only.

1. **CATEGORY 1**—NRHA Approved ancillary classes; World Champion and Top Ten awards to apply

a. **OPEN**—Subject to the general conditions, any rider holding a valid NRHA card may show any horse in the class.

(1) **INTERMEDIATE OPEN**—OPEN to any rider holding a valid NRHA card who has earned less than \$25,000 in NRHA Category 1, 2, 6 and 8 earnings over the previous three calendar years.

(2) **LIMITED OPEN**—Open to any rider holding a valid NRHA card who has earned less than \$7,500 in lifetime NRHA Category 1, 2, 6 and 8 earnings at the start of the NRHA year.

(3) **ROOKIE PROFESSIONAL**- Open to any rider, except those holding an NRHA Non Pro, Youth, or Youth Non Pro card, who has earned less than \$5,000 in NRHA lifetime earnings, all categories, at the start of the NRHA year. Can run concurrent with any Category 1 Open, Intermediate Open, or Limited Open class.

b. **NON PRO**—Open to any rider holding a valid NRHA Non Pro card as defined in the Non Pro section of the NRHA Handbook.

(1) **INTERMEDIATE NON PRO**—Open to any rider holding a valid NRHA Non Pro card who has earned less than \$15,000 in NRHA Category 1, 2, 6 and 8 earnings over the previous three calendar years.

(2) **LIMITED NON PRO**—Open to any rider holding a valid NRHA Non Pro card who has earned less than \$4,500 in Category 1, 2, 6 and 8 earnings over the three previous calendar years.

(3) Open to any rider holding a valid NRHA Non Pro card who is 50 or older as of January 1 of NRHA year. This class may run concurrent with the Category 1 (Non Pro, Intermediate Non Pro, or Limited Non Pro) class.

c. **NOVICE HORSE LEVEL 1** – Subject to the general conditions but restricted to horses that have not earned more than \$5,000 in lifetime earnings in all NRHA categories except 3, 7 and 9. Also available in the Non Pro division, however, the Non Pro division would be restricted to riders with a valid NRHA Non Pro card and would be restricted to the rules of ownership as stated in Non Pro conditions.

d. **NOVICE HORSE LEVEL 2** – Subject to the general conditions but restricted to horses that have not earned more than \$25,000 in lifetime earnings in all NRHA categories except 3, 7 and 9. Also available in the Non Pro division, however, the Non Pro division would be restricted to riders with a valid NRHA Non Pro card and would be restricted to the rules of ownership as stated in the Non Pro conditions.

2. **CATEGORY 2**—NRHA Approved Aged Events (Futurity, Derby and other approved Aged Events)

a. **Level 4 OPEN AGED EVENT**—Any rider holding a valid NRHA card may show in this division.

(1) **Level 3 (INTERMEDIATE) OPEN AGED EVENT**—Open to any rider holding a valid NRHA card who is not in the Top 50 money earners in open classes based on open earnings in Category 2 and 6 events for the previous three calendar years. In

addition, the Top 25 Non Pro riders based on total earnings in Category 2 and 6 events over the previous three calendar years, are not eligible. For members giving up Non Pro cards please refer to the Non Pro conditions.

(2) Level 2 (LIMITED) OPEN AGED EVENT—Open to any rider holding a valid NRHA card who has earned less than \$15,000 in lifetime NRHA Category 2 and 6 earnings at the start of the NRHA year. For members giving up Non Pro cards please refer to the Non Pro conditions.

(3) Level 1 OPEN AGED EVENT – Open to any rider holding a valid NRHA Non Pro or Youth membership card who has earned less than \$50,000 in lifetime NRHA earnings all categories at the start of the NRHA year.

(4) PRIME TIME OPEN - Open to any rider holding a valid NRHA card who is 50 or older as of January 1 of NRHA year. This class may run concurrent with the Category 2 (Open, Intermediate Open or Limited Open) class.

b. Level 4 NON PRO AGED EVENT—Restricted to Non Professional riders and eligible horses as defined in the Non Pro section.

(1) Level 3 (INTERMEDIATE) NON PRO AGED EVENT—Open to any rider holding a valid NRHA Non Pro card who is not in the Top 25 money earners based on total earnings in NRHA Category 2 and 6 events over the previous three calendar years.

(2) Level 2 (LIMITED) NON PRO AGED EVENT—Open to any rider holding a valid NRHA Non Pro card who is not in the Top 125 money earners in Non Pro classes based on Non Pro earnings in Category 2 and 6 events for the previous three calendar years.

(3) Level 1 NON PRO AGED EVENT – Open to any rider holding a valid NRHA Non Pro card who has earned less than \$25,000 in lifetime NRHA earnings all categories at the start of the NRHA year. For members giving up Non Pro cards please refer to the Non Pro conditions.

(4) PRIME TIME NON PRO - Open to any rider holding a valid NRHA Non Pro card who is 50 or older as of January 1 of NRHA year. This class may run concurrent with the Category 2 (Non Pro, Intermediate Non Pro, or Limited Non Pro) class.

3. CATEGORY 3 - YOUTH

a. YOUTH (13 & UNDER)

b. YOUTH (14-18)

c. YOUTH ROOKIE (18 & UNDER) - Open to youthriders who have not earned more than twenty-five (25) points in NRHA Youth Classes. Riders may use a horse without the restrictions of ownership for Youth classes as defined under Youth Conditions. Will not count toward Top Ten Standings. Youth Rookie may be run concurrently only with Youth classes.

4. CATEGORY 4 - Breed Restricted Classes. NRHA approved classes (excluding aged events) restricted by breed.

a. Jr Reining

b. Sr Reining

c. All Age Reining

d. Amateur Reining

e. Youth Reining

f. Open Reining

g. Non Pro Reining

5. CATEGORY 5

a. NRHA approved, NRHA rules to apply, but not for World Champion and Top Ten awards.

b. ROOKIE

(1) Rookie Level 1 – Open to any rider holding a valid NRHA Non Pro card who has earned less than \$200 in lifetime earnings in all NRHA categories except 3,7, and 9 or 50 youth points (excluding points earned in the Youth (10 & Under Short Stirrup class). Riders may use a horse without the restrictions of ownership for Non Pro classes as defined under Non Pro conditions. Horses are to be shown one handed. Rookie reining can only be run concurrent with Rookie level 2 or Prime Time Rookie. In order to offer Rookie Level 1, Rookie Level 2 must also be offered.

(2) Rookie Level 2 – Open to any rider holding a valid NRHA Non Pro card who had earned less than \$500 in lifetime earnings in all NRHA categories except 3, 7 and 9

or 100 youth points (excluding points earned in the Youth (10 & Under Short Stirrup class). Riders may use a horse without the restrictions of ownership for Non pro classes as defined under non pro conditions. Horses are to be shown one handed.

Rookie reining can only be run concurrent with Rookie level 1 or Prime time Rookie.

- c. PRIME TIME OPEN DIVISION—For persons 50 and older as of January 1st.
 - d. PRIME TIME ROOKIE DIVISION—For persons 50 and older as of January 1st. This class must run concurrent with the Rookie class. Money won in Prime Time Rookie competition will not count towards World Champion awards and will be used for determining eligibility status for the Rookie class only.
 - e. SNAFFLE BIT or HACKAMORE—Subject to the general conditions but limited to 3-, 4-, and/or 5-year-old horses to be shown in a smooth snaffle bit with a broken mouthpiece (conventional O-ring, eggbutt or D-ring) with ring no larger than 4" (102 mm) and no smaller than 2" (51 mm). One inch (25 mm) in from the cheek the mouthpiece must be a minimum 5/16" (8 mm) diameter with a gradual decrease to the center of the snaffle. Optional curb strap is acceptable, however curb chains are not acceptable. A flexible, braided rawhide, leather or rope bosal, the core of which may be either rawhide or flexible cable, may be used in lieu of a snaffle bit, but can be no larger than 3/4" (19 mm) in diameter at the cheek; there must be a minimum of a 2-finger space (approximately 1 1/2" [38 mm]) between the bosal and the horse's nose. Absolutely no rigid material will be permitted under the jaws, or on the noseband in connection with the bosal, regardless of how covered or padded. Horsehair bosals are prohibited. Horses entered in this class may be ridden with two hands.
 - (1) Show committees are allowed to offer the following Snaffle Bit or Hackamore classes or any combination of these classes: 3-year-old; 3- and 4-year-old; 4-year-old and under, 5- and under; 4- and 5-year-old. Open and Non Pro divisions may be offered.
 - f. FREESTYLE—see RN107.
 - h. ANCILLARY GELDING INCENTIVE CLASSES - Any ancillary class may offer this division. Entry into this class may be made only after entry into the corresponding class. The added money of the Gelding Incentive class cannot be higher than the added money of the corresponding class. These classes may be jackpotted or may have added money. There may or may not be a judges fee.
6. CATEGORY 6
- a. (NRHA Approved Closed Aged Events, NRHA rules to apply, but not for World Champion and Top Ten awards.)
 - b. Competition in this category is "closed." Closed competitions for these purposes are defined as those not open to all participants other than as described and defined in the NRHA Handbook. Closed Aged Events require entry using specific criteria other than defined in the NRHA Handbook, i.e. specific breeders futurities and derbies that require stallion subscription, foal nomination, breed or gender restrictions, or other such requirements to enter. Entry into the gelding incentive class may be made only after entry into the corresponding class.
 - c. The NRHA Executive Board will act on events applying for approval as a "closed," Category 6 event, but not specifically described herein. The NRHA will consider the merit of any event requesting approval as a "closed" competition.
 - d. The Category 6 classes are to be patterned after the Category 2, classes.
7. CATEGORY 7
- a. Affiliate Championship Finals; require qualification through the NRHA Affiliate Championship program to enter.
8. CATEGORY 8
- a. NGB & FEI COMPETITIONS
 - b. (NGB—National Governing Body, FEI—Federation Equestre Internationale—To include recognized and/or approved events such as World Equestrian Games, Pan Am Games, CRI's—Concours de Reining International, CRIO's—Concours de Reining International Official etc.)
 - c. Recorded events
 - (1) All placings are recorded by NRHA. Non member/non-licensed horses will appear as such in NRHA records.
 - (2) Results to be received from official source.

d. Affiliate Level Classes

(1) The NRHA recognizes the need for diversity in classes held at different levels of competition and in different geographical areas, as well as to generate promotional activity for affiliate groups. This diversity allows for growth and development of affiliates and uniqueness in show management.

(2) Among these types of classes are: Geldings, Green as Grass, Green Reiner, Ladies, Mens, and many additional classes with a variety of individual conditions written by the affiliate or show management. These classes often use NRHA rules with a noted variation in show conditions to accommodate the specific class.

(3) NRHA does not sanction these classes for national competition, but does recognize and encourage their use for the growth and development of the affiliates, the interest of the exhibitors, and the overall management of the reining show. Official NRHA trophies and plaques will not be awarded in Affiliate Level classes. Awards that are offered through an NRHA approved class as an incentive to a specific breed and/or gender.

9. CATEGORY 9 - (Freestyle classes only, NRHA rules to apply, but not for World Champion and Top Ten awards, see Freestyle Reining section of NHRA Handbook)

a. FREESTYLE OPEN - Any rider holding a valid NRHA card may show in this class,

b. FREESTYLE NON PRO - Any rider holding a valid NRHA Non Pro card may show in this class.

RN105 Non Pro Conditions.

1. A Non Pro shall be defined as a person who at the time of Non Pro application has not won in excess of \$100,000 (one hundred thousand dollars) in Category 1, 2 and 6 open reining competition. A Non Pro shall also be defined as a person who has not directly (money) or indirectly (goods or services) received remuneration for showing, training, or assisting in the training of any horse ridden astride, regardless of discipline or breed - this does not include prize money. A Non Pro shall be further defined as a person who has not given lessons for remuneration. An exception exists with respect to a Non Pro applicant that is certified as an instructor in national equine equitherapy as exemplified by the North American Riding for the Handicapped Association (NARHA). The excepted instructor shall only teach students enrolled with an approved organization or students prescribed such rehabilitation by a licensed medical doctor. A Non Pro applicant is excepted under this provision and must have disclosed this information on the Non Pro Declaration that is submitted to the NRHA office. Payment of entry fees and/or expenses by anyone other than the Non Pro, his/her immediate family, or a corporation, partnership or other business entity in which the Non Pro and/or a member of his/her immediate family are the sole and only owner, shall be considered remuneration except for demonstrations, exhibitions, or international team competitions where the Non Pro is representing his/her National Federation, or competition where the Non Pro is representing his/her college or university as an individual or part of a team. A horse shown in Non Pro competition must be solely and completely owned by one of the following:

a. the Non Pro

b. a member or members of his/her immediate family

c. a corporation, partnership, or other business entity provided that the Non Pro and/or a member or members of his/her immediate family are the sole and only owners of that business entity and the ownership of that business entity does not change to include non immediate family members or entities. Ownership will be evidenced by the competition license. Note: NRHA has adopted the following definition of immediate family: husband, wife, parent, step-parent, legal guardian, child, step-child, brother, sister, half brother, half sister, aunt, uncle, niece, nephew, grandmother, grandfather and in-laws, of the same relations as stated above.

It is the responsibility of the Non Pro to file an Immediate Family Form with the NRHA prior to showing an immediate family member's horse. The Non Pro is also responsible for updating that form with any changes. If there is not an Immediate Family Form on file with the NRHA office, a Non Pro may be forfeited out of any NRHA Non Pro classes in which they have shown.

2. Any transaction relating to the sale of a horse to a Non Pro other than by immediate family members, must be at fair market value. The Non Pro is responsible for documenting said transaction in a satisfactory fashion in the event of any protest. If a Non Pro and/or his

or her immediate family member sells a horse and then buys it back, the Non Pro and/or his or her immediate family member cannot show that horse in Non Pro classes for 180 days from the time he or she originally sold the horse.

3. The Executive Board or a committee designated by them shall have the right to review in detail any transaction regarding the purchase or sale of a horse by the holder of a NRHA Non-Professional card if in their judgment there was an intent to misuse the rules of the Association. At the Executive Board or its designated committee's discretion, there shall be a review if a horse is repurchased or resold. Included in the review shall be methods of procurement, all transfer records, canceled checks, and deposit slips if so directed by the Executive Committee. The procurement of mortality insurance and a receipt of payment to a third party is an acceptable proof of sale. The original owner's knowledge of the sale is not necessary for proof of sale involving an agent. All parties to a transaction in violation of these NRHA rules are subject to disciplinary action.

4. Procedure for those applying for Non Pro status:

a. An applicant must complete the official NRHA Non Pro Membership Application, and submit to the NRHA Office with the appropriate fee.

b. Persons applying for non pro status who reside on, work for, or derive monetary sustenance from a horse training and/or showing facility and persons included in advertising for horse facilities and operations or publicly identified in any way with horse facilities must complete Sections A & B of the Non Pro Membership Application.

c. A Non Pro card is a privilege and not a right. The NRHA Non Pro Committee will screen all applicants. The NRHA Non Pro Committee can require at any time a Non Pro to submit his/her card for review of applicability. The NRHA Non Pro Committee can refuse a Non Pro Card to anyone deemed not in compliance with the eligibility criteria set forth in the NRHA Handbook.

d. An applicant must obtain a Non Pro card prior to entering a Non Pro class; applicants must allow thirty days minimum for processing applications. Earnings will not count for top ten purposes and all Non Pro winnings earned prior to approval will be forfeited if it is determined that the Non Pro approval was not granted prior to showing. Failure to comply with the application requirements as specified in the NRHA Handbook may result in disciplinary action.

e. Denial of non pro status may be appealed to the NRHA Board of Directors.

f. A professional (excluding members in the Apprentice program) desiring to obtain Non Pro status may do so after meeting all Non Pro conditions for a period of time equal to the number of years they have not met the Non Pro requirements with a minimum of three (3) years and maximum of five (five) years. The NRHA office may then be notified and the standard Non Pro Membership application and fees may be submitted for approval or disapproval by the NRHA Board of Directors or their designate. The applicant will be notified of the approval or disapproval by the office and shall not show in NRHA Non Pro competition until notified.

g. A professional who attains Non Pro status after fulfilling stated criteria, shall not be eligible for any reining classes or divisions, specifically Limited Non Pro or Intermediate Non Pro, (Category 1 or 2 and 6) for an additional three years.

5. Should a member wish to protest the eligibility of a Non Pro, he may file a protest to the NRHA Office in accordance with the procedures set forth in the disciplinary procedure section of the NRHA Handbook. The protest must be signed by a current NRHA member in good standing. In protests regarding the eligibility of a Non Pro, the 10-day rule for filing such protests is not applicable. In these types of protests, he or she must file within the current or subsequent year of the actual incident. Upon receipt of a validly filed protest, the Non Pro Committee may choose to request the individual in question to voluntarily return his/her Non Pro card. If the individual chooses not to surrender his/her card, the committee shall send the issue to the NRHA Investigation Review Committee established for Non Pros.

6. Renewing Non Pro status:

a. Annual renewal of a Non Pro card will not require a new Non Pro declaration if no change in status has occurred.

b. Following any lapse in NRHA membership a Non Pro will be required to re-file a new Non Pro Declaration, as well as a Supplement form if applicable.

7. Penalty: should the NRHA Executive Board determine a Non Pro has made a false declaration, the Non Pro will forfeit all Non Pro winnings earned during the current year, and be subject to disciplinary procedures. When a horse/rider is found to be ineligible, the earnings and awards will be forfeited to the NRHA. Upon receipt of the earnings, NRHA will redirect the forfeited earnings to the show committee to be redistributed. NRHA will make corrections to the class placing and earnings in the database. It is the responsibility of the exhibitor to return all forfeited earnings to the NRHA and all prizes and awards to the Competition Secretary.

8. Relinquishing Non Pro Status

A Non Pro that gives up his/her Non Pro status, and becomes a professional must notify the NRHA/Federation offices in writing within thirty (30) days of the change. Non Pro earnings in any category/class will not be utilized in determining current eligibility, with the exception of the Rookie Professional class (see definition of Rookie Professional).

9. Non Pro Apprenticeship Exemption

a. A Non Pro may participate in the Apprenticeship Program only once. The Non Pro must complete an Apprenticeship Program Application.

b. An Apprenticeship Program applicant may be subject to a personal interview with the Non Pro Committee.

c. Apprenticeship status must be granted by the NRHA Board of Directors following the recommendation of the Non Pro Committee.

d. The applicant must apprentice with a member of the NRHA Professionals and physically work at that Professional's facility.

e. All NRHA previous Non Pro as well as Open earnings will be used to determine the Apprentice's class eligibility. The Apprentice can only show in Open division classes during the apprenticeship period.

f. All applicants must be at least 18 years of age.

g. There is no earnings limit.

h. Apprenticeship is a 12 month consecutive period. At the end of that time, the apprentice may remain an open rider. In this case, previous Non Pro earnings will be backed out for eligibility purposes. If the Apprentice does remain an Open rider, the Apprentice must then reapply for Non Pro status and is subject to the Non Pro conditions. Any monies won during the 12 consecutive month Apprenticeship shall be applied to his/her Non Pro eligibility.

RN106 Freestyle Reining.

1. Reining maneuvers originated from moves that a cowhorse must use in performing its duties and have been refined to the high level of competition existing today. Freestyle Reining not only provides an opportunity to use these maneuvers creatively, but also to expand them to music by means of choreography. Riders are encouraged to use musical scores which permit them to show the athletic ability of the horse in a crowd appealing way.

2. NRHA rules will apply except where the following rules pre-empt same.

3. REQUIRED MANEUVERS will be defined as follows:

A minimum of 4 consecutive spins to the right. A minimum of 4 consecutive spins to the left.

A minimum of 3 stops. A minimum of 1 lead change at the canter from right to left. A minimum of 1 lead change at the canter from left to right. Exhibitors will only be judged astride.

Exhibitors are allowed to use two hands (as well as one or no hands) and any bit approved by the NRHA rule book, including snaffle bits and bosals approved for use in the Snaffle bit or Hackamore classes. Failure to perform all the required maneuvers or failure to complete the performance within the time limit will result in a 0. Additional maneuvers such as roll-backs, backups, speed variations, and non classical reining maneuvers such as half pass and side pass are appropriate in Freestyle and shall be given appropriate credit. Additional repetitions of required maneuvers are appropriate, but will only add or subtract from the existing scores already given for the required maneuvers, not as additional scores.

4. TIME LIMIT is a maximum of 4 minutes including any introductions. The time limit will be from the beginning of the music or from the beginning of the introduction (whichever is first) and will end with the music.

5. COSTUMES are permitted but not required. Emphasis is placed on performing the reining maneuvers to music.

6. PROPS are permitted but at no time may hinder the judges' view of the horse. The use of props will not add to the score.

7. **JUDGING OF THE FREESTYLE REINING.** Required maneuvers in Freestyle will receive a score based on technical merit from the technical judges utilizing judges score sheets specifically designed for the Freestyle. Transitional maneuvers and other maneuvers not specified as reining maneuvers will be evaluated and scored accordingly in a specified box and counted as a single maneuver score. If an artistic impression judge is used, they must use the score sheet provided by NRHA and are encouraged to include remarks regarding performance. In the event an artistic judge is not used, the technical judges will assess an artistic impression score in the box specified using a –2 to a +2 evaluation.

8. **NUMBER OF JUDGES:** Two or more licensed Reining judges must be used in any Freestyle class that offers \$2000 or more in added money.

In the case of one or two judges being used, they would be required to be NRHA approved. They would judge the technical merit of the ride. As part of the overall score, each judge would weigh the artistic impression of the ride as 10% of the overall ride.

9. **TIE BREAKER JUDGE.** One judge (not to be an artistic impression judge) shall be designated as the tie breaker prior to the Freestyle class. In the event a tie still occurs (or the tie occurs with one judge), the technical merit scores will be tallied to break the tie. In the event a tie remains, the exhibitors tied will be declared co-champions. (Exception—NRHA page #28, rule 14).

10. **VALIDATING REQUIRED MANEUVERS** will be the responsibility of the judges. At least one scribe will be used to assist in verifying the required maneuvers for each horse as they are completed in the pattern.

11. **ELIMINATIONS** are to be used at the discretion of competition management and should use NRHA patterns, NRHA judging rules as applied to Category 1 classes, and NRHA judges. Eliminations may be held without music or costuming, but must allow the use of either one or two hands. The emphasis in the design of any eliminations should be on quality of competition.

12. **APPLAUSE METERS** or Artistic impression judges should not represent more than 20% of the combined score and should only be used in conjunction with (minimum) two NRHA approved judges. When used in scoring, the following formulas should be applied to properly weigh the scores according to the above percentage and still produce a comparable numerical score as when three judges are used.

- a. Score for Judge 1 should be multiplied by 1.2
- b. Score for Judge 2 should be multiplied by 1.2
- c. Score for the Applause Meter should be multiplied by .6. All three scores should then be added to determine the final score for placing.

13. If an open Freestyle Reining class is offered a Non Pro Freestyle class may also be held. Competition management will reserve the right to run them concurrently or separately.

14. **COMPETITION MANAGEMENT** will reserve the right to rule on music or dress which may be inappropriate or offensive to the spirit and nature of the competition. Competition management may also determine the use of special lighting.

15. **EQUIPMENT** used in freestyle must adhere to the following standards:

- a. All equipment must be non-abusive and humane based on Federation and NRHA Rules and guidelines.
- b. Any equipment not specifically covered by or in conflict with standard equipment guidelines must be non-abusive to the horse.

SUBCHAPTER RN-2 PATTERNS.

RN107

1. The following patterns are to be worked as stated, not as drawn. The drawn pattern is just to give the general idea of what the pattern will look like in the arena.

2. Markers will be placed on the wall or fence of the arena as follows:

- a. at the center of the arena
- b. at least 50' (15 meters) from each end wall.

3. Where designated in the Pattern for stops to be beyond a marker, the horse should begin his stop after he passes the specified marker.

4. Each pattern is drawn so that the bottom of the page represents the end of the arena entered by contestants and must be run as such. In the event that an arena has only one gate and it be in the exact middle of the side, that side shall represent the right side of the page the pattern is drawn on.

5. All horses will be judged immediately upon entering the arena and judging will cease after the last maneuver. Any fault incurred prior to the commencement of a pattern will be scored accordingly.
6. All judges' decisions are final.

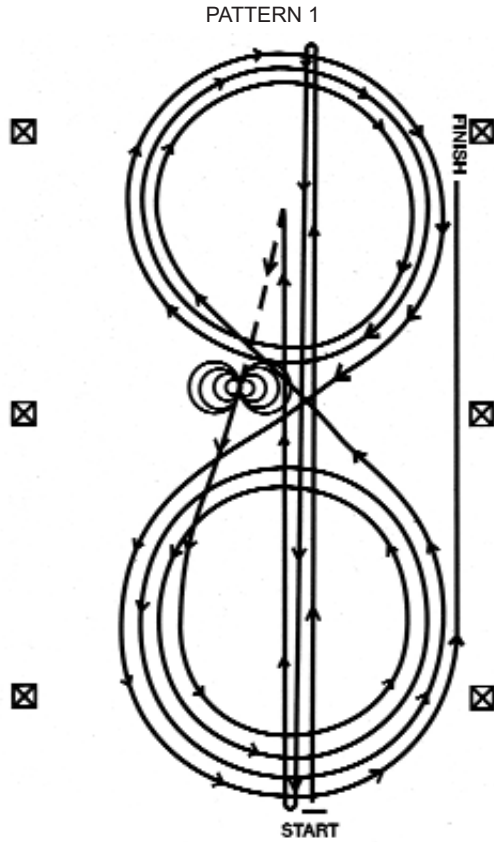

1. Run at speed to the far end of the arena past the end marker and do a left roll back—no hesitation.
2. Run to the opposite end of the arena past the end marker and do a right rollback—no hesitation.
3. Run past the center marker and do a sliding stop. Back up to center of the arena or at least ten feet (three meters). Hesitate.
4. Complete four spins to the right. Hesitate.
5. Complete four and one-quarter spins to the left so that horse is facing left wall of fence. Hesitate.
6. Beginning on the left lead, complete three circles to the left: the first circle large and fast; the second circle small and slow; the third circle large and fast. Change leads at the center of the arena.
7. Complete three circles to the right: the first circle large and fast; the second circle small and slow; the third circle large and fast. Change leads at the center of the arena.
8. Begin a large fast circle to the left but do not close this circle. Run straight up the side of the arena past the center marker and do a sliding stop at least twenty feet (six meters) from wall or fence. Hesitate to demonstrate the completion of the pattern. Rider must drop bridle to the designated judge or steward as designated by the judge.

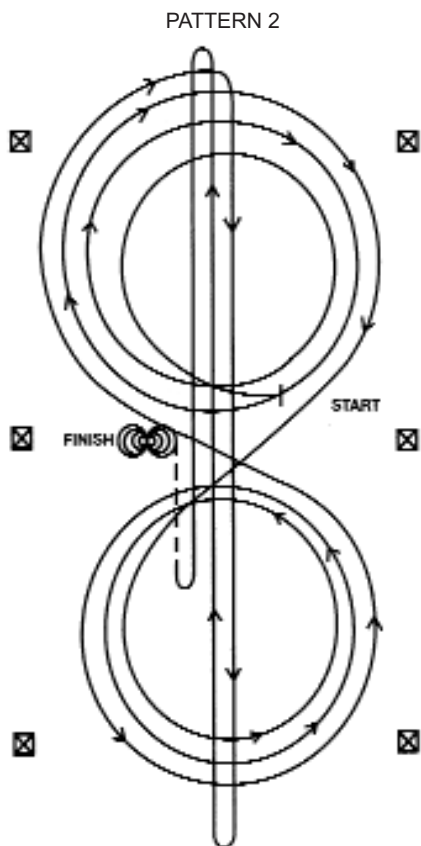

Horses may walk or trot to the center of arena. Horses must walk or stop prior to starting the pattern. Beginning at the center of the arena facing the left wall or fence.

1. Beginning on the right lead, complete three circles to the right: the first circle small and slow; the next two circles large and fast. Change leads at the center of the arena.
 2. Complete three circles to the left: the first circle small and slow; the next two circles large and fast. Change leads at the center of the arena.
 3. Continue around previous circle to the right. At the top of the circle, run up the middle to the far end of the arena past the end marker and do a right roll back—no hesitation.
 4. Run up the middle to the opposite end of the arena past the end marker and do a left roll back—no hesitation.
 5. Run past the center marker and do a sliding stop. Back up to the center of the arena or at least ten feet (three meters). Hesitate.
 6. Complete four spins to the right. Hesitate.
 7. Complete four spins to the left. Hesitate to demonstrate the completion of the pattern.
- Rider must drop bridle to the designated judge or steward as designated by the judge.

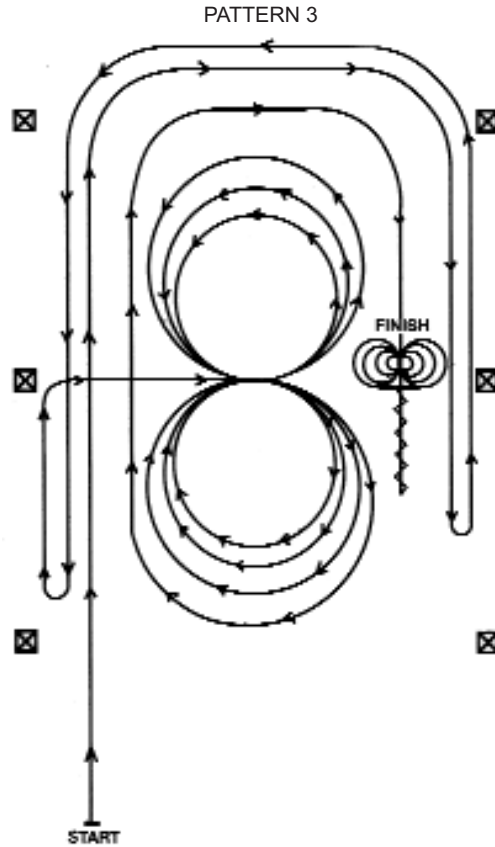

1. Beginning, and staying at least twenty feet from the walls or fence, lope straight up the left side of the arena, circle the top end of the arena, run straight down the opposite or right side of the arena past the center marker and do a left rollback—no hesitation.
2. Continue straight up the right side of the arena staying at least twenty feet from the walls or fence, circle back around the top of arena, run straight down the left side of the arena past the center marker and do a right rollback—no hesitation.
3. Continue up the left side of arena to the center marker. At the center marker, the horse should be on the right lead. Guide the horse to the center of the arena on the right lead and complete three circles to the right: the first two circles large and fast; the third circle small and slow. Change leads at the center of the arena.
4. Complete three circles to the left: the first two circles large and fast; the third circle small and slow. Change leads in the center of the arena.
5. Begin a large fast circle to the right but do not close this circle. Continue up the left side of the arena staying at least twenty feet (six meters) from the walls or fence, circle the top of the arena, run straight down the opposite or right side of the arena past the center marker and do a sliding stop. Back up at least ten feet (three meters). Hesitate.
6. Complete four spins to the right. Hesitate.
7. Complete four spins to the left. Hesitate to demonstrate completion of the pattern. Rider must drop bridle to the designated judge or steward as designated by the judge.

PATTERN 4

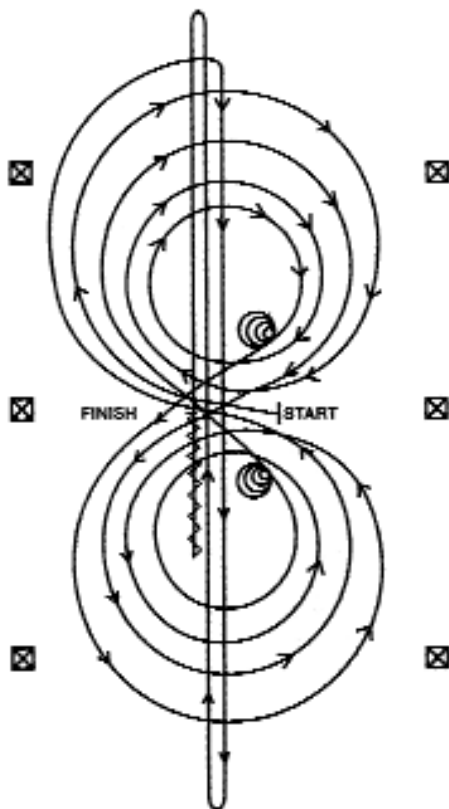

Horses may walk or trot to the center of arena. Horses must walk or stop prior to starting the pattern. Beginning at the center of the arena facing the left wall or fence.

1. Beginning on right lead, complete three circles to the right: the first two circles large and fast; the third circle small and slow. Stop at the center of the arena. Hesitate.
2. Complete four spins to the right. Hesitate.
3. Beginning on the left lead, complete three circles to the left: the first two circles large and fast; the third circle small and slow. Stop at the center of the arena. Hesitate.
4. Complete four spins to the left. Hesitate.
5. Beginning on right lead, run a large fast circle to the right, change leads at the center of the arena, run a large fast circle to the left, and change leads at the center of the arena (figure 8).
6. Continue around previous circle to the right. At the top of the circle, run down the middle to the far end of the arena past the end marker and do a right roll back—no hesitation.
7. Run up the middle to the opposite end of the arena past the end marker and do a left roll back—no hesitation.
8. Run past the center marker and do a sliding stop. Back up to the center of the arena or at least ten feet (three meters). Hesitate to complete demonstration of the pattern. Rider must drop bridle to the designated judge or steward as designated by the judge.

PATTERN 5

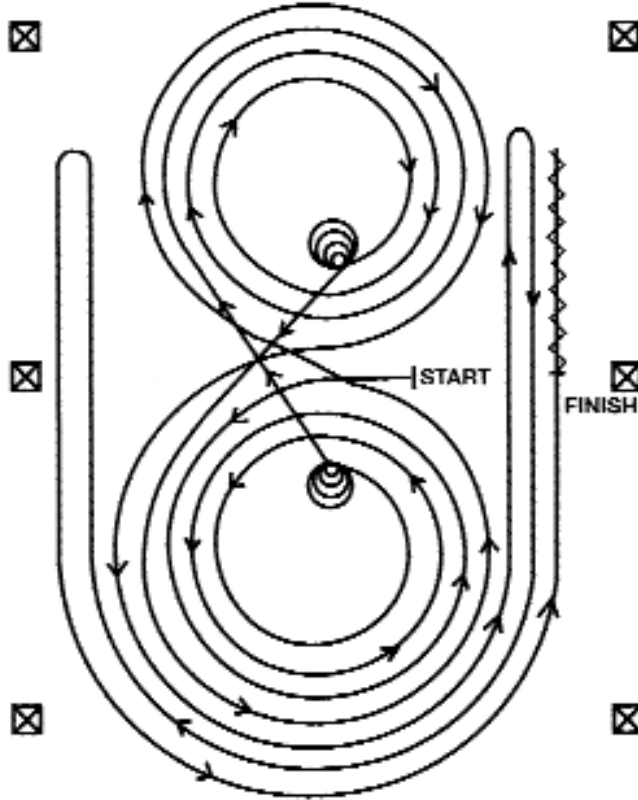

Horses may walk or trot to the center of arena. Horses must walk or stop prior to starting the pattern. Beginning at the center of the arena facing the left wall or fence.

1. Beginning on the left lead, complete three circles to the left: the first two circles large and fast; the third circle small and slow. Stop at the center of the arena. Hesitate.
2. Complete four spins to the left. Hesitate.
3. Beginning on the right lead, complete three circles to the right: the first two circles large and fast; the third circle small and slow. Stop at the center of the arena. Hesitate.
4. Complete four spins to the right. Hesitate.
5. Beginning on left lead, run a large fast circle to the left, change leads at the center of the arena, run a large fast circle to the right, and change leads at the center of the arena (figure 8).
6. Continue around previous circle to the left but do not close this circle. Run up the right side of the arena past the center marker and do a right rollback at least twenty feet (six meters) from the wall or fence—no hesitation.
7. Continue around previous circle but do not close this circle. Run up the left side of the arena past the center marker and do a left rollback at least twenty feet (six meters) from the wall or fence—no hesitation.
8. Continue back around previous circle but do not close this circle. Run up the right side of the arena past the center marker and do a sliding stop at least twenty feet (six meters) from the wall or fence. Back up at least ten feet (three meters). Hesitate to demonstrate completion of the pattern. Rider must drop bridle to the designated judge or steward as designated by the judge.

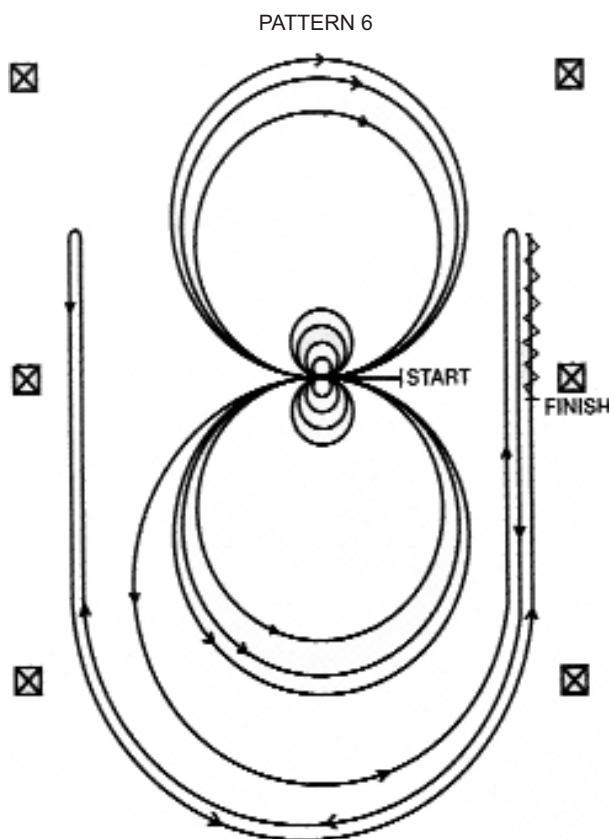

Horses may walk or trot to the center of arena. Horses must walk or stop prior to starting the pattern. Beginning at the center of the arena facing the left wall or fence.

1. Complete four spins to the right. Hesitate.
2. Complete four spins to the left. Hesitate.
3. Beginning on the left lead, complete three circles to the left: the first two circles large and fast; the third circle small and slow. Change leads at the center of the arena.
4. Complete three circles to the right: the first two circles large and fast; the third circle small and slow. Change leads at the center of the arena.
5. Begin a large fast circle to the left but do not close this circle. Run up the right side of the arena past the center marker and do a right rollback at least twenty feet (six meters) from the wall or fence—no hesitation.
6. Continue back around previous circle but do not close this circle. Run up the left side of the arena past center marker and do a left rollback at least twenty feet (six meters) from the wall or fence—no hesitation.
7. Continue back around previous circle but do not close this circle. Run up the right side of the arena past the center marker and do a sliding stop at least twenty feet (six meters) from the wall or fence. Back up at least ten feet (three meters). Hesitate to demonstrate the completion of the pattern. Rider must drop bridle to the designated judge or steward as designated by the judge.

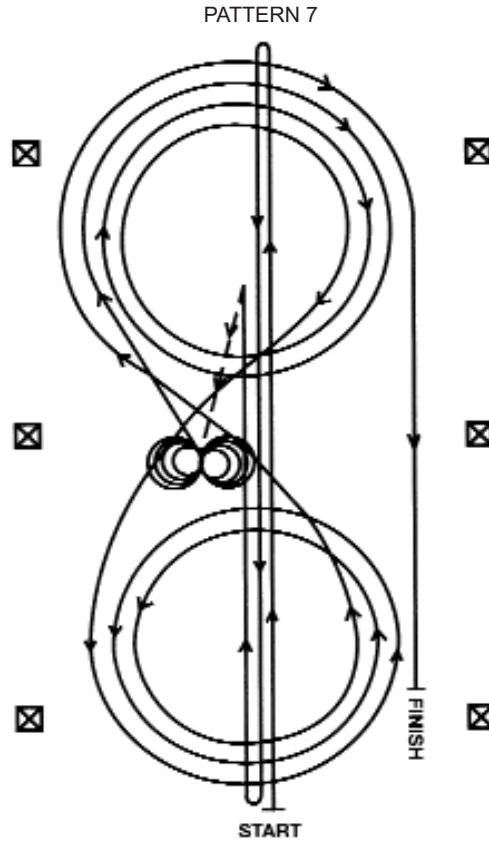

1. Run at speed to the far end of the arena past the end marker and do a left rollback—no hesitation.
2. Run to the opposite end of the arena past the end marker and do a right rollback—no hesitation.
3. Run past the center marker and do a sliding stop. Back up to the center of the arena or at least ten feet (three meters). Hesitate.
4. Complete four spins to the right. Hesitate.
5. Complete four and one-quarter spins to the left so that horse is facing left wall or fence. Hesitate.
6. Beginning on the right lead, complete three circles to the right: the first two circles large and fast; the third circle small and slow. Change leads at the center of the arena.
7. Complete three circles to the left: the first two circles large and fast; the third circle small and slow. Change leads at the center of the arena.
8. Begin a large fast circle to the right but do not close this circle. Run straight down the right side of the arena past the center marker and do a sliding stop at least twenty feet (six meters) from the wall or fence. Hesitate to demonstrate the completion of the pattern. Rider must drop bridle to the designated judge or steward as designated by the judge.

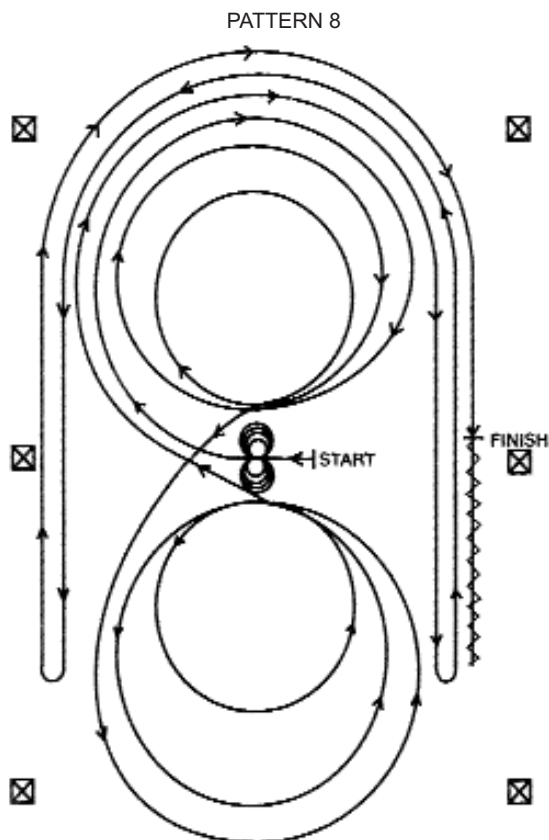

Horses may walk or trot to the center of arena. Horses must walk or stop prior to starting the pattern. Beginning at the center of the arena facing the left wall or fence.

1. Complete four spins to the left. Hesitate.
2. Complete four spins to the right. Hesitate.
3. Beginning on the right lead, complete three circles to the right: the first circle large and fast; the second circle small and slow; the third circle large and fast. Change leads at the center of the arena.
4. Complete three circles to the left: the first circle large and fast; the second circle small and slow; the third circle large and fast. Change leads at the center of the arena.
5. Begin a large fast circle to the right but do not close this circle. Run straight down the right side of the arena past the center marker and do a left rollback at least twenty feet (six meters) from the wall or fence—no hesitation.
6. Continue back around the previous circle but do not close this circle. Run down the left side of the arena past the center marker and do a right rollback at least twenty feet (six meters) from the wall or fence—no hesitation.
7. Continue back around the previous circle but do not close this circle. Run down the right side of the arena past the center marker and do a sliding stop at least twenty feet (six meters) from the wall or fence. Back at least ten feet (three meters). Hesitate to demonstrate the completion of the pattern. Rider must drop bridle to the designated judge or steward as designated by the judge.

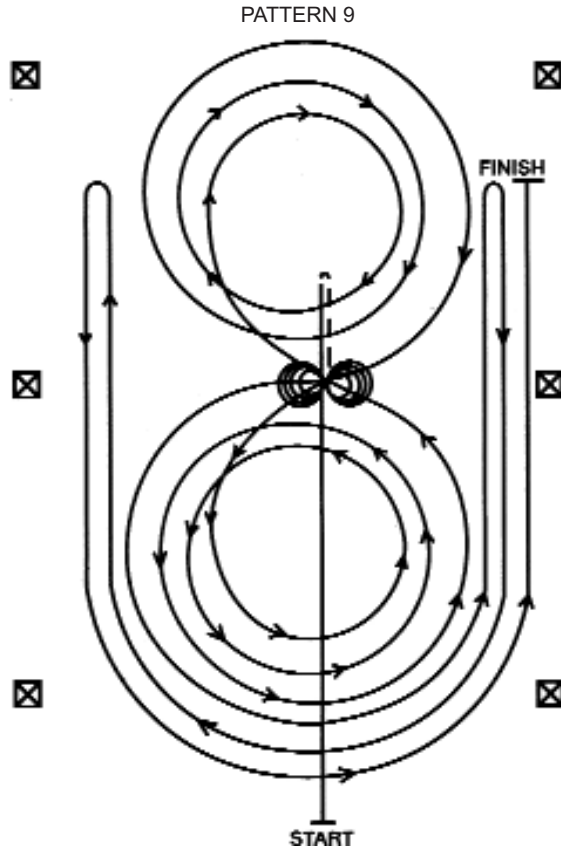

1. Run past the center marker and do a sliding stop. Back up to the center of the arena or at least ten feet (three meters). Hesitate.
2. Complete four spins to the right. Hesitate.
3. Complete four and one-quarter spins to the left so that horse is facing the left wall or fence. Hesitate.
4. Beginning on left lead, complete three circles to the left: the first circle small and slow; the next two circles large and fast. Change leads at the center of the arena.
5. Complete three circles to the right: the first circle small and slow; the next two circles large and fast. Change leads at the center of the arena.
6. Begin a large fast circle to the left but do not close this circle. Run up the right side of the arena past the center marker and do a right rollback at least twenty feet (six meters) from the wall or fence—no hesitation.
7. Continue back around the previous circle but do not close this circle. Run up the left side of the arena past the center marker and do a left rollback at least twenty feet (six meters) from the wall or fence—no hesitation.
8. Continue back around previous circle but do not close this circle. Run up the right side of the arena past the center marker and do a sliding stop at least twenty feet (six meters) from the wall or fence. Hesitate to demonstrate the completion of the pattern. Rider must drop bridle to the designated judge or steward as designated by the judge.

PATTERN 10

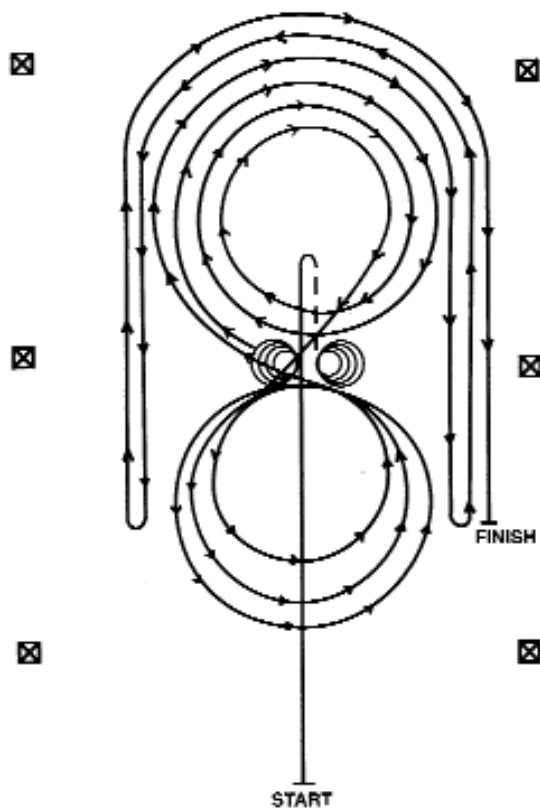

1. Run past the center marker and do a sliding stop. Back up to the center of the arena or at least ten feet (three meters). Hesitate.
2. Complete four spins to the right. Hesitate.
3. Complete four and one quarter spins to the left so that the horse is facing the left wall or fence. Hesitate.
4. Beginning on the right lead, complete three circles to the right: the first two circles large and fast, the third circle small and slow. Change leads at the center of the arena.
5. Complete three circles to the left: the first circle small and slow, the next two circles large and fast. Change leads at the center of the arena.
6. Begin a large fast circle to the right but do not close this circle. Run down the right side of the arena past the marker and do a left roll back at least twenty feet (six meters) from the wall or fence—no hesitation.
7. Continue back around the previous circle but do not close this circle. Run down the left side of the arena past the center and do a right roll back at least twenty feet (six meters) from the wall or fence—no hesitation.
8. Continue back around previous circle but do not close this circle. Run down the right side of the arena past the center marker and do a sliding stop at least twenty feet (six meters) from the wall or fence. Hesitate to demonstrate completion of the pattern. Rider must drop the bridle to the designated judge or steward as designated by the judge.