

Excluding SVO in Ergative Languages: A New View on Mahajan's Generalisation

Antje Lahne*

Abstract

This paper offers a new derivation of Mahajan's Generalisation. The basic idea of the new analysis is that in ergative languages, the external and the internal argument always end up as specifiers of the same head. Consequently, there is no position between them that the verb could possibly fill. In accusative languages, on the other hand, DP_{ext} and DP_{int} end up as specifiers of different heads, so that there is at least one head between them that the verb can fill. The reason for this structural difference is that in ergative languages, in contrast to accusative languages, case assignment dependencies are nested. This in turn is due to the different order of application of Merge and Value operations in the two classes of languages.

1. Introduction

Mahajan (1994; 1997) is the first formal implementation of the empirical generalisation that ergative languages do not exhibit verb-medial basic word order.

(1) *Mahajan's Generalisation (Mahajan 1994; 1997):*

Ergative languages exhibit SOV and VSO order, but not SVO.

The goal of this paper is to derive this generalisation in a minimalist framework.

*For helpful comments and discussion, I would like to thank Petr Biskup, Fabian Heck, Gereon Müller, Marc Richards, the participants of Tarald Taraldsen's seminar on Ergativity in spring 2008 at the university of Tromsø (especially Pavel Caha, Xuan Di, Gillian Ramchand, Michal Starke and Peter Svenonius), and the audience at the workshop "Perspektiven minimalistischer Syntax" (Leipzig, October 2008). Particular thanks goes to Tarald Taraldsen, who brought up the issue, encouraged people to come up with new solutions and allowed me to present this account in his seminar, and to Peter Jurgec, who stayed awake and discussed matters with me a whole blue arctic spring night through. This research was supported by the *2008 Research Grant for the State of Saxony*.

2. Previous Analyses

2.1. Mahajan (1994, 1997)

Mahajan's (1994; 1997) analysis derives the argument structure from the basic word order of languages ("SVO, therefore not ergative"). The analysis correlates two empirical observations: Firstly, only verb-peripheral languages exhibit ergative case marking pattern, whereas SVO languages are never ergative; secondly, the auxiliary *have* usually occurs in SVO languages only. This correlation is shown in table 1.

		ERGATIVITY	AUX 'HAVE'
<i>Mahajan's</i>	VERB-PERIPHERAL LANGUAGES	✓	rare
<i>Generalisation</i>	VERB-MEDIAL LANGUAGES	—	✓

The basic assumption in Mahajan's analysis is a stricter version of Baker's (1988) Uniformity of Theta Assignment Hypothesis.

- (2) *Uniformity of Theta Assignment Hypothesis (UTAH; Baker 1988):*
Identical thematic relationships between items are represented by identical structural relationships between those items at the level of D-structure.
- (3) *Extended UTAH (Mahajan 1994; 1997):*
Identical (thematic) relationships between items not ONLY have identical structural relationships but they are also represented by identical categorial structures. That is, the categories that are involved in representing these structural relationships are also the same.

The starting point of the analysis are the following two analyses: Firstly, in Hindi, the subject is a PP marked with an ergative postposition¹; in French, on the other hand, the subject is an unmarked NP. Secondly, the auxiliary is *have* in French, and *be* in Hindi. This is shown in (4).

- (4) a. Rām-ne vah kitā-bē paṛ^h-īī hē
 Ram-ERG.MASC those book-FEM.PL read-PERF.F.PL be:PRES.PL
 'Ram has read those books' (Hindi)

¹Evidence for the ergative marker being a postposition: (1) it can be separated from the NP by an emphatic marker; (2) it does not appear twice on a coordinated NP.

- b. Jean a cuit les tomates
 Jean has cooked the tomatoes
 ‘Jean has cooked the tomatoes’ (French)

A consequence from the Extended UTAH is that the category of the subject must be the same in (4-a) and (4-b). Mahajan suggests that the subject in French is originally a PP (of which the head corresponds to the Hindi P head *ne* ‘ERG’). The auxiliary *have* is taken to be composed of BE plus an incorporated empty adposition, which originates as the sister of the external argument (Freeze 1992; Kayne 1993). In French, P is incorporated into I, which yields the *have*-auxiliary. In Hindi, on the other hand, P spells out as the ergative marker, as it cannot incorporate into I. This is due to a condition on incorporation which is not fulfilled in verb-final languages like Hindi: Incorporation requires adjacency. The relevant configurations in verb-final and verb-medial languages are shown in (5) and (6).

- (5) Structure in SOV languages:

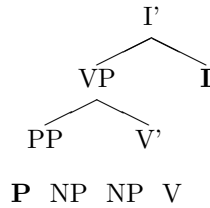

- (6) Structure in SVO languages:

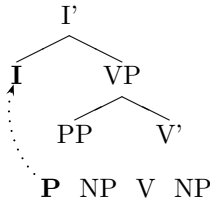

In SOV languages, P and I are not adjacent, so that P-I incorporation is impossible. Thus, I surfaces as *be*, and P surfaces as the ergative marker on NP_{ext}. In SVO languages, on the other hand, P and I are adjacent, so that P, which would otherwise surface as the ergative marker, incorporates into I. P+I then surface as the auxiliary *have*, and the external argument does not bear an oblique case marker; it surfaces with nominative case. Consequently, SVO languages never yield ergative morphology. A second consequence of the analysis is that perfective constructions like (4-b) are always underlyingly ergative.

2.2. Bittner and Hale (1996)

Bittner and Hale's (1996) theory of argument structure also includes an account of Mahajan's Generalisation. In this theory, the basic word order of a language follows from its argument structure ("ergative, therefore not SVO"). The system works in such a way that the case of primary arguments is determined by two heads, K_1 ($=[\text{erg}]=I$) and K_2 ($=[\text{acc}]=v$). Case assignment happens by case binding. If a K cannot case-bind an argument, then the derivation does not crash, but the argument is assigned the default case ($=\text{nom}$). There are two conditions on case binding: K must c-command the argument, and there must be a case competitor (caseless coargument) in the local m-command domain of K . In ergative languages, $K_1=I$ case-binds the external argument, and $K_2=v$ does not determine a structural case. Thus, NP_{int} does not receive structural case, but it is a case competitor for NP_{ext} . The case competitor can become visible to I in two ways: by being remerged as SpecI, and by V-to-I movement (head movement opens barriers). The absence of SVO order in ergative languages can now be derived in the following way (Bittner and Hale 1996: 14): In ergative languages, I case-binds the external argument in NP_{ext} 's base position at the edge of V (the case competitor NP_{int} becomes visible to I if V-to-I movement takes place, which opens the VP barrier). Crucially, there is no motivation for NP_{ext} to move to the edge of I in order to become visible for I . If, however, NP_{ext} does not need to move, then it must not move. This follows from the Last Resort Condition:

- (7) *Last Resort* (Chomsky 1991; 1995):
 Movement must result in feature checking.

As a result, NP_{ext} is not remerged as SpecI; SVO cannot be derived in ergative languages.

A third analysis is proposed by Sauerland (1995): Ergative case features are checked at LF, which is not possible if the subject is in a position higher than the verb.

These accounts, however, have a number of problems, some of which are discussed in detail in Sauerland (1995). In addition, the desideratum is to have an account of the data in a more recent minimalist framework.

3. New Analysis

3.1. Basic Idea

The new analysis basically works in such a way that both ergativity and *SVO result from independent properties of a certain class of languages.

The starting point of the analysis is the observation that a verb-initial word order is a derived word order. It can be derived from both SOV and SVO orders. Deriving VSO from SVO is straightforward: V is raised over S.

- (8) Deriving VSO from SVO
 $S\ V\ O \rightarrow \underbrace{V\ S}\ O$

How is VSO derived in SOV languages? There are two possible ways: Firstly, by moving the verb in one step; secondly, by moving the verb in two steps, via the order SVO. This is shown in a simplified way in (9) and (10).

- (9) Deriving VSO from SOV: one step
 $S\ O\ V \rightarrow \underbrace{V\ S}\ O$

- (10) Deriving VSO from SOV: two steps (via SVO)
 $S\ O\ V \rightarrow S\ \underbrace{V\ O} \rightarrow \underbrace{V\ S}\ \underbrace{O}$

I would like to propose that derivation (10) does not arise in ergative languages. The reason for this is that in ergative languages, the external and the internal argument both end up as specifiers of the same head; consequently, there is no position between them that the verb could possibly fill. In accusative languages, on the other hand, NP_{ext} and NP_{int} end up as specifiers of different heads, so that there is a head between them that the verb can fill. The underlying reason for this different behaviour is that in ergative languages, in contrast to accusative languages, case assignment dependencies are nested, as illustrated in (11). This in turn is due to the different order of application of Merge and Value operations in the two classes of languages.

(11) Case assignment patterns

- a. Case assignment in accusative languages
(pretheoretical, without phases)

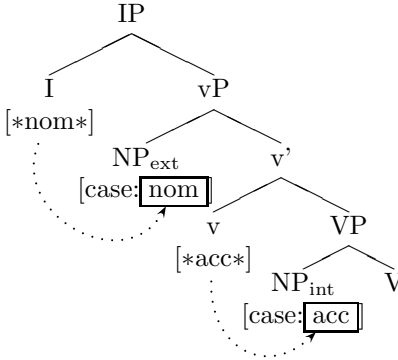

- b. Case assignment in ergative languages
(pretheoretical, without phases)

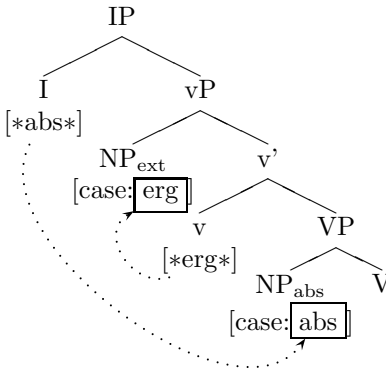

3.2. Theoretical Background

The underlying argument structure is such that *v* assigns internal case (=accusative, ergative), *I* assigns external case (=nominative, absolutive); the internal argument is merged as the sister of *V*, and the external argument as Spec,*v* (e.g. Murasugi 1992). There is only one structural argument encoding feature [case], which has two values: ext(ernal) and int(ernal) (determined with respect to *vP*, the predicate domain). The feature specification [CASE:ext] replaces [abs] and [nom]; and [CASE:int] replaces [erg], [acc] (e.g. Müller 2008).

The principle the new analysis rests upon is the Earliness Principle, which is given in (12).

(12) *Earliness Principle:*

An uninterpretable feature must be marked for deletion as early in the derivation as possible (Pesetsky 1989; Pesetsky and Torrego 2001).

A further relevant notion is the definition of Agree.

(13) *Agree:*

α can agree with β with respect to a feature bundle Γ iff (a), (b) and (c) hold:

- a. α bears a probe feature [$*F*$] in Γ , β bears a matching goal feature [F] in Γ .
- b. α m-commands β .
- c. There is no δ such that (i) and (ii) hold:
 - (i) δ has a feature [F].
 - (ii) δ is closer to α than β (= the path from δ to α is shorter than the path from β to α).

(13) includes the definition of an intervener in terms of path length. Path is defined in terms of cardinality as follows:

(14) *Path:*

The path from A to B is the set of categories C such that (a) and (b) hold:

- (a) C dominates A or B.
- (b) The minimal XP that dominates C is the minimal XP that dominates both A and B.

(14) has three main effects: Firstly, specifier and complement of a head α are equally close to α ; secondly, the specifier of α is closer to α than any category that is further embedded in the complement of α (Pesetsky 1982; Collins 1994); thirdly, elements at the edge of the complement of α are equidistant to α (Chomsky 2001:27).

3.3. Analysis

In what follows, the structures given in the analysis are head-initial. This is in order to show that SVO cannot be derived in ergative languages even if the language is underlyingly head-initial (which in fact advantages verb-medial structures).

The analysis starts with an account of the goings-on at vP stage (section 3.3.1), which follows Müller (2008). This part is important, though Mahajan's Generalisation is a result of what happens at a later stage, as it

introduces the crucial mechanism the new analysis rests upon. Section 3.3.2 is the new part of the analysis. It examines what is going on at I level, and gives the account of why ergative languages do not display SVO order.

3.3.1. *VP/vP*

The context is a simple transitive predicate with NP_{int} , NP_{ext} . I adopt the account of accusative and ergative patterns put forth by Müller (2008). Let me briefly present this account: The common derivational steps for both accusative and ergative language types is that V merges with NP_{int} (see (15)), and then v is merged (see (16)).

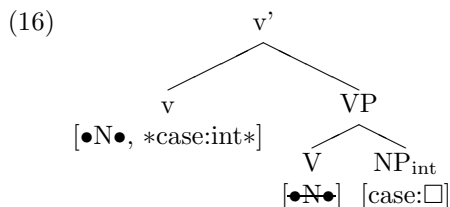
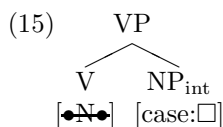

At this point, an indeterminacy in rule application arises: v contains an unsatisfied feature ($[\ast\text{case:int}\ast]$) and a structure-building feature ($[\bullet\text{N}\bullet]$). The next operation could therefore either be $\text{Value}(v, \text{NP}_{\text{int}})$, or $\text{Merge}(v, \text{NP}_{\text{ext}})$. The Earliness Principle has the effect that if Merge and/or Value are possible at a stage of the derivation, then they must apply at once. In other words,

there is a dilemma: Only one operation can apply first, as required by Earliness. [...] I would like to contend that conflicts of this type are real, and must be resolved in a language by giving one Earliness requirement priority over the other in the case of conflict – in other words, in ranking the two requirements. [This] is in fact all that needs to be assumed to derive the core difference between accusative and ergative encoding patterns. (Müller 2008)

Some languages resolve the indeterminacy in rule application by giving Value priority over Merge. The order of feature handling in these languages is thus $[\ast\text{case:int}\ast] \gg [\bullet\text{N}\bullet]$. This finally yields an accusative pattern: At

first, v agrees with NP_{int} in $[*case:int*]$, then NP_{ext} is merged (see (17) and (18)).

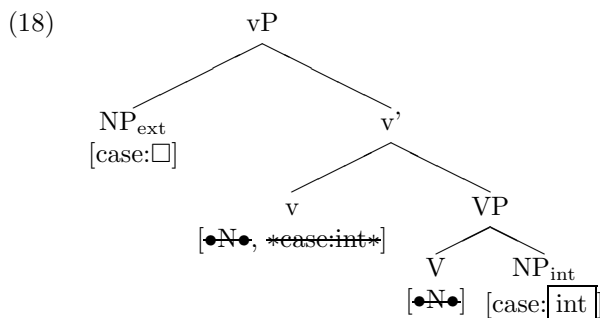
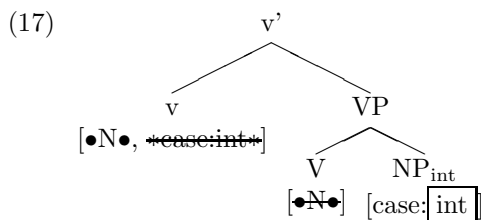

NP_{ext} , which is located at the edge of v , later receives external case from I.

There are also languages that resolve the indeterminacy in rule application by giving Merge priority over Value. In these languages, the order of feature handling on v is thus $[•N•] \gg [*case:int*]$. This gives rise to an ergative pattern. Here NP_{ext} is merged first:

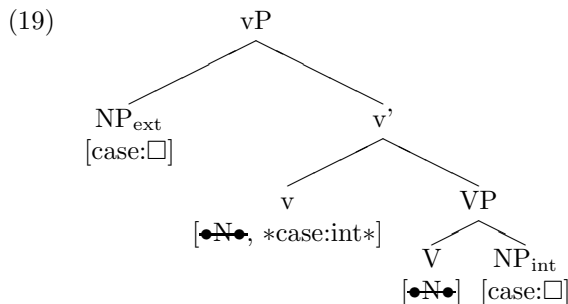

Now $[*case:int*]$ must be assigned. It can, however, not be assigned to NP_{int} , as, the path from v to NP_{ext} is shorter than the path from v to NP_{int} . As a result, NP_{ext} is assigned internal case:

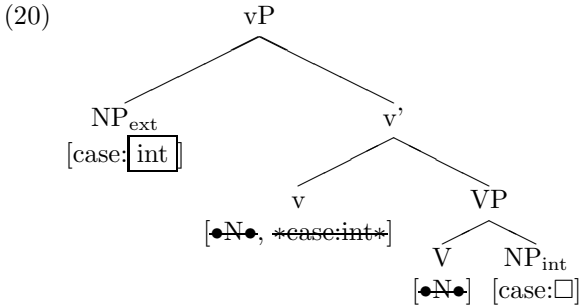

This is the point where the new analysis steps in. Crucially, NP_{int} must be remerged at the edge of v , as the complement of the phase head v is spelled out as soon as the $v\text{P}$ is complete; however, the case feature of NP_{int} has not been valued yet. I assume that there is a shape preservation movement at this stage of the derivation: NP_{ext} is remerged again above NP_{int} , or NP_{int} is not merged as the highest specifier, but tucked in (Richards 1997) lower than NP_{ext} , as shown in (21).

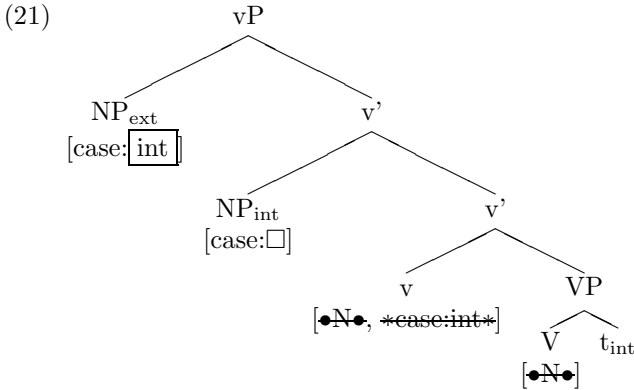

3.3.2. *IP*

Mahajan's Generalisation is a result of what happens at the I level: The feature set of I contains $[\ast\text{case:ext}\ast]$, and can contain an EPP feature $[\bullet\text{N}\bullet]$. Again, an indeterminacy in rule application arises when I is merged: The next operation could either be $\text{Value}(\text{I}, \text{NP}_{\text{int}})$, or $\text{Merge}(\text{I}, \text{NP}_{\text{ext}})$.

It was stated above that in languages finally showing an accusative pattern, the order of operation application is $\text{Value} \gg \text{Merge}$. Thus, the order of feature handling of I is $[\ast\text{case:ext}\ast] \gg [\bullet\text{N}\bullet]$. There are four different

constellations that can arise: In case 1, I has an EPP feature, and v-to-I movement takes place. The derivation proceeds in such a way that I first values the case feature of NP_{ext}, and subsequently NP_{ext} is remerged as SpecI. As the illustration in (22) shows, this yields **SVO**.

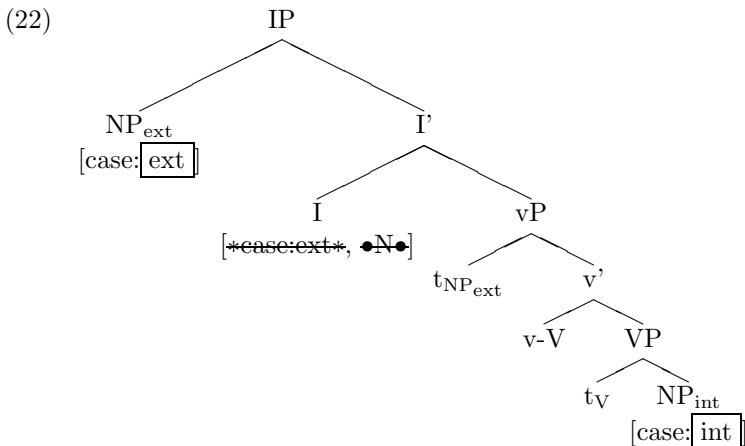

In case 2, I has an EPP feature, but there is no v-to-I movement. The outcome is almost identical to that in case 1, the only difference being that the verb is located in v. Case 3 is a constellation in which I has no EPP feature, and there is no V-to-I movement. As there is no structure building feature present, the indeterminacy in rule application does not arise in the first place. I only values the case feature of NP_{ext} (see (23)). This yields **SVO**.

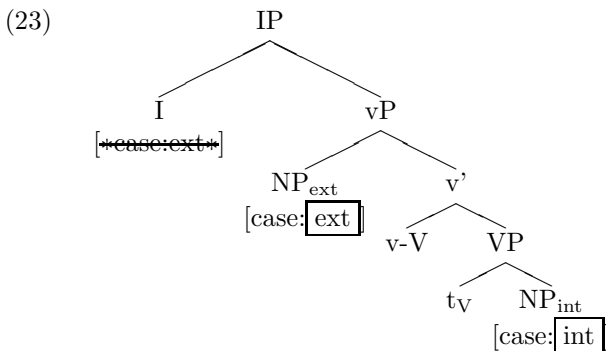

There is a fourth possible derivation in which I has no EPP feature, and there is V-to-I movement. Here V moves to I, but no relevant indeterminacy

in rule application arises – I only values the case feature of NP_{ext} . This yields **VSO**:

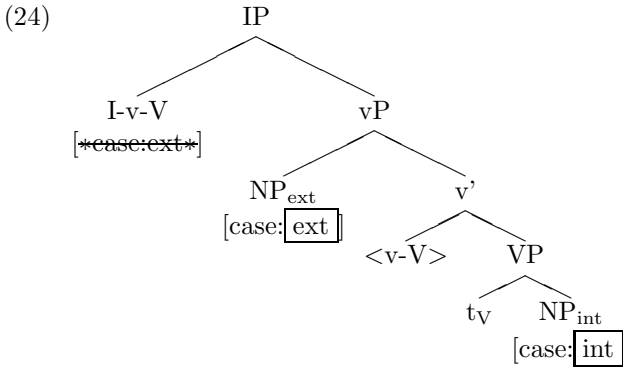

Let us now turn to ergative languages. In languages that finally show an ergative pattern, the order of operation application is Merge \gg Value. Thus, for I, the order of feature handling is [\bullet N \bullet] \gg [*case:ext*]. Again, there is cross-linguistic variation in the presence of an EPP feature and in the occurrence of v-to-I movement, and again, there are four possible derivations: In case 1, I has an EPP feature, and v moves to I. Here the first operation following the head movement is that I remerges NP_{ext} as its specifier. This would yield SVO; however, the subsequent step in the derivation prevents it: [*case:ext*] must be handled next. The derivation encounters the same constellation as within the vP: NP_{ext} is closer to I than NP_{int} . The case feature of the intervening NP_{ext} is, however, already valued this time. Still, I cannot value the case feature of NP_{int} , because NP_{ext} is an defective intervener for Value. This follows from the definition of intervener in ((13)c): NP_{ext} is closer to I than NP_{int} is, and NP_{ext} has feature of the same kind as the feature to be valued. The situation is illustrated in (25). As a result, the derivation crashes.

(25)

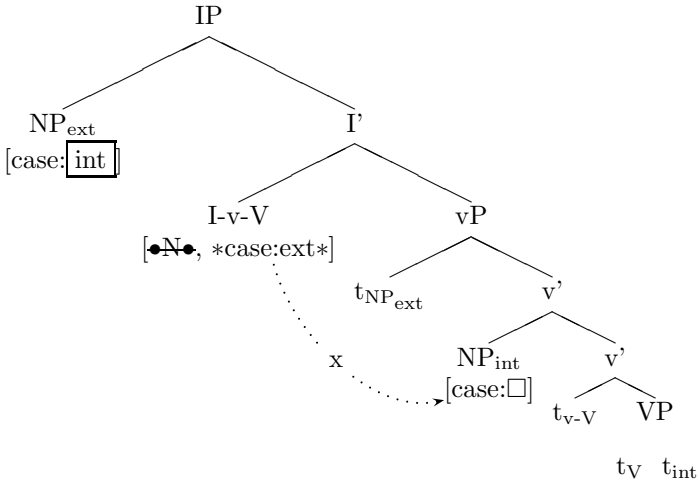

Note the same constellation would not lead to an intervention effect in an accusative language, as unvalued features are handled before structure-building features in this language type, so that the case feature is already dealt with when NP_{ext} is remerged. In case 2, I has an EPP feature, but there is no V-to-I movement. This derivation, too, crashes due to defective intervention: First, I remerges NP_{ext} as its specifier, which would yield SOV. Now the same reasoning as above applies: [*case:ext*] must be handled next, but cannot be handled by agreeing with NP_{int}, as NP_{ext} intervenes (see (26)). This derivation crashes.

(26)

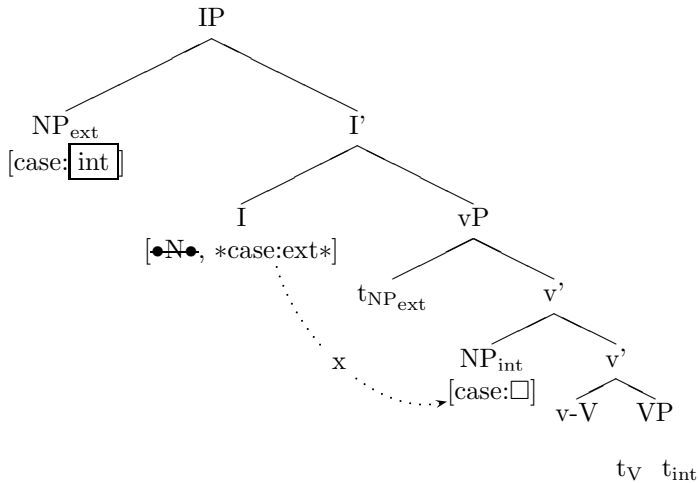

In a third possible derivation, I has no EPP feature, and there is V-to-I movement. No indeterminacy in rule application arises here in the first place: V-to-I movement takes place, and I values the case feature of NP_{ext}. This yields **VSO**.

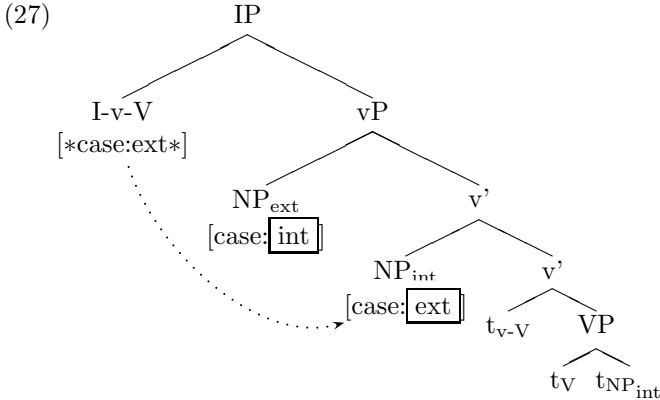

A question that has to be addressed at this point is why NP_{ext} is not a defective intervener for agree in (27). The answer is that NP_{ext} and NP_{int}, both specifiers of v, are *equidistant*. This follows from the definition of *Path* in ((14)b): The node v' in (27) does not count as a step on the path between I and NP_{int}, because the minimal XP that dominates it is vP, which does not dominate I. NP_{ext} and NP_{int} are therefore equidistant from I.

In the fourth and last case, I has no EPP feature, and there is no V-to-I movement. Here again, no indeterminacy in rule application arises. I values the case feature of NP_{int}. This yields **SOV**:

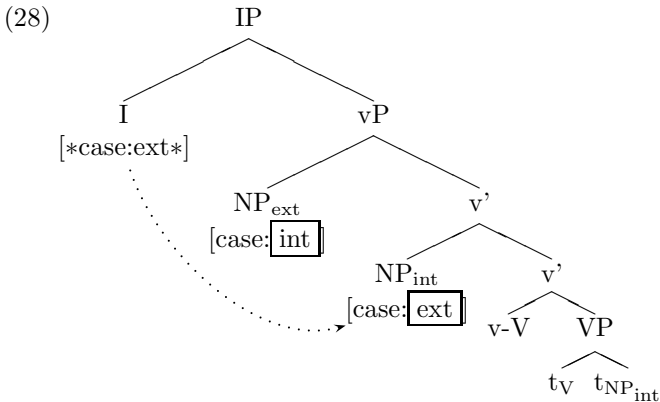

3.4. Consequences

The new analysis makes the strong prediction that there is no EPP feature proper on I in ergative languages. A second prediction is that there is no V-to-I movement in ergative SOV languages. This is arguably true for languages like Adyghe and Burushaski; however, the prediction is not borne out for Hindi (SOV, split-ergative): There is evidence that I has an EPP feature in Hindi, and that the ergative argument is a specifier of I (Anand and Nevins 2006).² These data can, however, be accounted for by assuming that there *is* a way of rescuing the derivation when there is defective intervention: NP_{int} is last-resort-moved to the edge of I and tucked in below the internal argument (due to shape preservation). Then NP_{ext} and NP_{int} are equidistant, and I can assign case to NP_{int}. Again, this yields **SOV**.

Bibliography

- Anand, Pranav and Andrew Nevins (2006): The Locus of Ergative Case Assignment: Evidence from Scope. *In*: A. Johns, D. Massam and J. Ndayiragije, eds, *Ergativity: Emerging Issues*. Kluwer, Dordrecht, pp. 3–25.
- Baker, Mark (1988): ‘Morphological and Syntactic Objects: A Review of Di Sciullo and Williams’, *Yearbook of Morphology* **1**, 259–283.
- Bittner, Maria and Ken Hale (1996): ‘The Structural Determination of Case and Agreement’, *Linguistic Inquiry* **27**(1), 1–68.
- Chomsky, Noam (1991): Some Notes on Economy of Derivation and Representation. *In*: R. Freidin, ed., *Principles and Parameters in Comparative Grammar*. MIT Press, Cambridge, Mass., pp. 417–454.
- Chomsky, Noam (1995): *The Minimalist Program*. MIT Press, Cambridge, Mass.
- Chomsky, Noam (2001): Derivation by Phase. *In*: M. Kenstowicz, ed., *Ken Hale: A Life in Language*. MIT Press, Cambridge, Mass., pp. 1–52.
- Collins, Chris (1994): ‘Economy of Derivation and the Generalized Proper Binding Condition’, *Linguistic Inquiry* **25**(1), 45–61.
- Freeze, R. (1992): ‘Existentials and Other Locatives’, *Language* **68**, 553–595.
- Kayne, Richard S. (1993): ‘Toward a Modular Theory of Auxiliary Selection’, *Studia Linguistica* **47**(1), 3–31.
- Mahajan, Anoop (1994): The Ergativity Parameter: *Have-be* Alternation,

²Marc Richards, p.c.

- Word Order and Split Ergativity. In: *Proceedings of NELS 24*. GLSA, Amherst, pp. 317–331.
- Mahajan, Anoop (1997): Universal Grammar and the Typology of Ergative Languages. In: A. Alexiadou and T. A. Hall, eds, *Studies on Universal Grammar and Typological Variation*. John Benjamins, Amsterdam, pp. 35–57.
- Müller, Gereon (2008): ‘Ergativity, Accusativity, and the Order of Merge and Agree’. Manuscript, Universität Leipzig.
- Murasugi, Kumiko (1992): Crossing and Nested Paths. PhD thesis, MIT, Cambridge, Mass.
- Pesetsky, David (1982): Paths and Categories. PhD thesis, Massachusetts Institute of Technology, Cambridge, Mass.
- Pesetsky, David (1989): ‘Language-particular Processes and the Earliness Principle’. Manuscript, MIT, Cambridge, Mass.
- Pesetsky, David and Esther Torrego (2001): T to C Movement: Causes and Consequences. In: M. Kenstowicz, ed., *Ken Hale: A Life in Language*. MIT Press, MIT, Cambridge, Mass., pp. 355–426.
- Richards, Norvin (1997): What Moves Where When in Which Language?. PhD thesis, Massachusetts Institute of Technology, Cambridge, Mass.
- Sauerland, Uli (1995): The *Lemmings* Theory of Case. In: J. Boro, L. Conway, P. Hsiao and E. Laurençot, eds, *Proceedings of SCIL VII*. MIT Working Papers in Linguistics, Cambridge, Mass.