



Technical Specifications
B&T MP9/TP9

manufactured by Brügger & Thomet AG, Switzerland



Brügger & Thomet AG
P.O. Box 42 • 3608 Thun
Switzerland
Fon +41 33 334 67 00
Fax +41 33 334 67 01
info@brugger-thomet.ch
www.brugger-thomet.ch

TS-MP9.01

Technical Specifications



Table of Contents:

1. General description	3
2. Nomenclature and technical data	4
3. Operating principle	7
4. Compatible ammunition	9
5. Exploded views and parts lists	10
6. Accessories	14
7. Manufacturer's warranty information	20

Related documents

TM-95106

SM-95106

1. General description

The MP9 is a compact, lightweight submachine gun and the perfect tool for personal protection and defense. At the size and the weight of a pistol, the MP9 is offering fire power and effective range of a rifle-sized submachine gun. Although being very small, the MP9 is offering many interfaces to install today tactical accessories such as suppressors and electro-optical aiming devices.

Actually, the MP9 is not only a weapon but a weapon family, including the fully automatic MP9, the semi-automatic TP9, the training weapon MP9-FX for Simunition 9mm FX cartridges and finally the completely inert red MP9-M.

2. Nomenclature and technical data

2.1 Nomenclature



Fig. 2.1

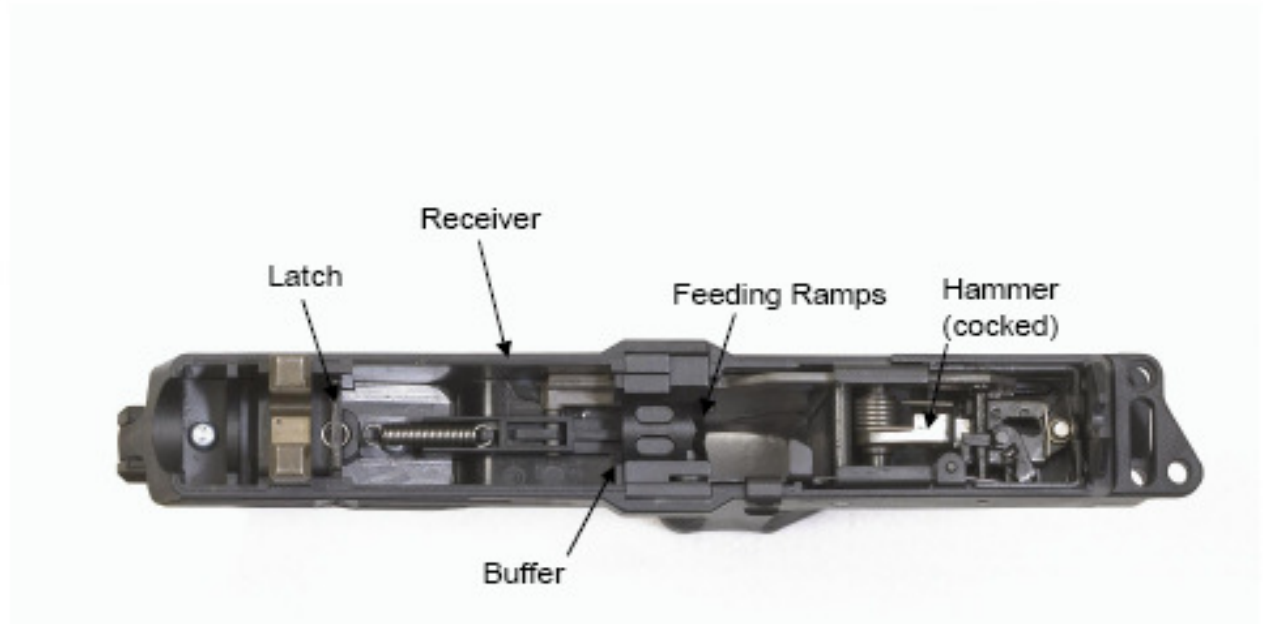
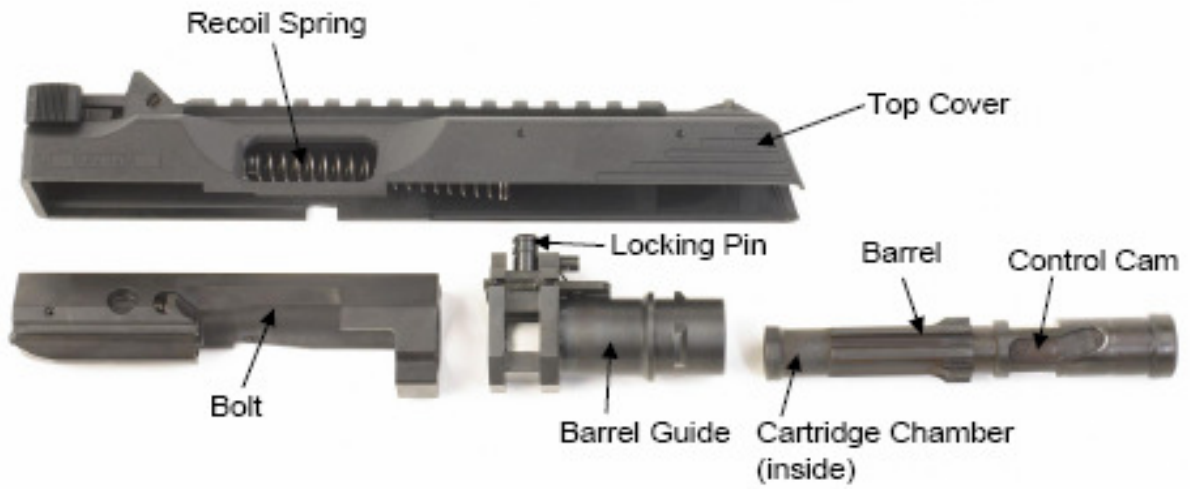

Fig. 2.2

Technical Specifications





2.2 Technical Data



Function:	Locking Rotating Barrel System Locked Closed Bolt Action Blow Back operated Bolt remains open after last shot
Safety System:	Double trigger safety Drop safety
Firing modes:	Semi-Automatic Full-Automatic (MP9 only) Ambidextrous fire selector switch
Magazines:	15, 20, 25 and 30 cartridges High-strength, translucent polymer
Sighting System:	Ghost-ring sight, fully adjustable MIL-STD 1913 Picatinny rail
Length:	523 mm (stock extended) 303 mm (stock closed)
Height:	166 mm (w/o magazine) 173 mm (with 15 round magazine) 246 mm (with 30 round magazine)
Width:	45 mm (stock folded out) 56 mm (stock closed)
Barrel Length:	150 mm
Sight Radius:	190 mm
Weight:	1.4 kg without magazine
Magazine Weight:	240 g 15 cartridges loaded (NATO 124 g) 300 g 20 cartridges loaded (NATO 124 g) 370 g 25 cartridges loaded (NATO 124 g) 440 g 30 cartridges loaded (NATO 124 g)
Colours:	black, green, tan

Ordering informations:

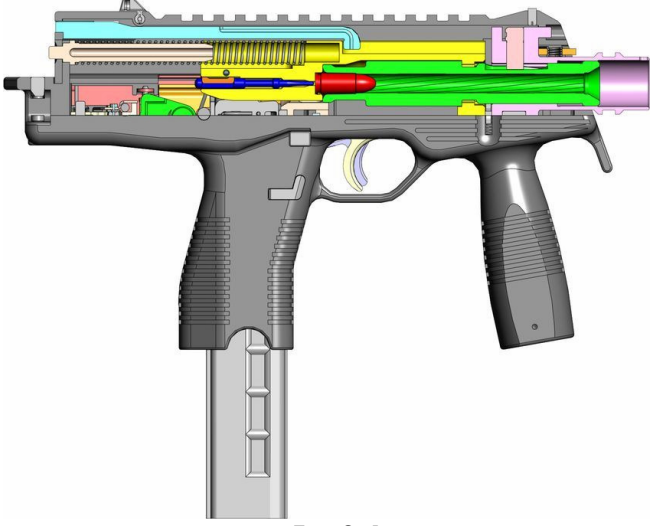
Item	Part number
MP9 cal. 9x19 mm in black, green or tan	BT-30104
Idem with side rail	BT-30104-1
TP9 cal. 9x19 mm in black, green or tan	BT-30105
Idem with side rail	BT-30105-1

3. Operating principle

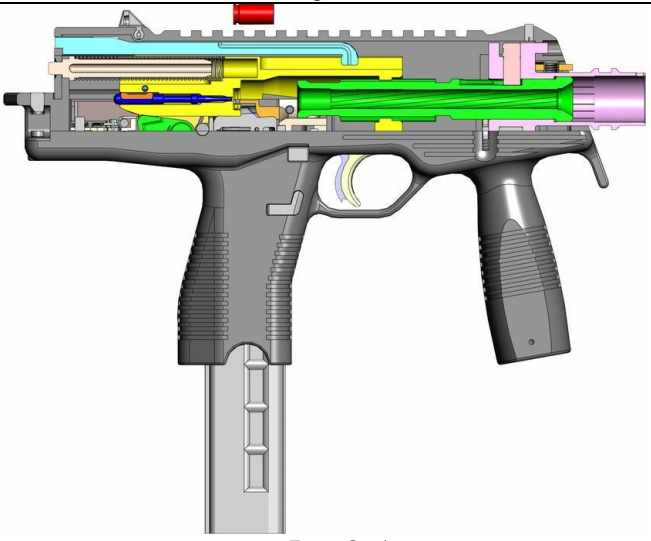
<p>Phase 1: Ready for firing</p> <ul style="list-style-type: none"> - cartridge in chamber - hammer cocked under force of hammer spring 	 <p style="text-align: center;">Fig 3.1</p>
<p>Phase 2: Ignition</p> <ul style="list-style-type: none"> - trigger releases hammer - hammer hits firing pin - firing pin ignites powder in cartridge - gases of burning powder drive bullet through barrel 	 <p style="text-align: center;">Fig. 3.2</p>
<p>Phase 3: Muzzle departure</p> <ul style="list-style-type: none"> - impulse of accelerating bullet drives locked firing unit (barrel and bolt) rearward against force of recoil spring - after muzzle departure of bullet, locked firing unit continues running rearward - barrel starts rotating around his axis, guided by the locking pin of the barrel guide running in the control cam of the barrel - bolt starts pushing hammer down against force of hammer spring 	

<p>Phase 4: Ejection</p> <ul style="list-style-type: none"> - barrel completes rotation and unlocks from receiver - barrel remains in position, bolt continues travelling rearward - extractor pulls empty cartridge case out of chamber and ejector throws it through the ejection port out of the weapon - bolt travels rearward until rearmost position while fully cocking hammer 	<p style="text-align: center;">Fig. 3.3</p> 
<p>Phase 5: Reloading</p> <ul style="list-style-type: none"> - compressed recoil spring pushes bolt back against barrel - forward travelling bolt feeds new cartridge out of magazine into chamber - forward riding bolt locks with barrel - locked firing unit rides to foremost position - disconnecter reengages trigger for next shot - ready for firing as fig. 3.1 	<p style="text-align: center;">Fig. 3.4</p>  <p style="text-align: center;">Fig. 3.5</p>

4. Compatible ammunition

Caliber: 9x19 NATO (also named 9 mm Luger, 9 mm Parabellum)

Cartridge Minimum Length: 27.0 mm recommended

Cartridge Minimum Impulse: 2.3 Ns recommended

Sight-In Distance: 10 m recommended

Point-Blank-Range: 0 m to 100 m (for target dia. 100 mm)

Practical Accuracy (meas.): Standard deviation 19 mm at 25 m (2.5 MOA)

Ballistic Performance:

Cartridge	v3 [m/s]	E3 [J]	Cartridge	v3 [m/s]	E3 [J]
B&T Subsonic 158 grs	270	374	Norma 7.5 g FMJ	344	444
B&T Training 8.0 g	378	570	Olin M882 112 grs	367	490
Corbon +P 115 grs JHP	407	619	PMC 95 grs Starfire	399	492
DAG 6 g Action 3	396	471	PMP 115 grs FMJ	337	426
DAG Action 6.1 g	422	542	Portugal Standard	347	482
DAG Sintox Action 6.1g	422	543	Remington +P 115grs JHP R9MM6	382	547
DAG Subsonic 10 g FMJ	290	421	Remington 124 grs MC R9MM2	337	455
DAG SX-2 bleifrei 8g	361	521	Remington Desintegrator 101 grs	369	448
Federal 115 grs Hi-Shok JHP	351	460	Remington Golden Saber 124 grs JHP	347	483
Federal Hydra-Shok 124 grs	337	455	Remington Golden Saber 147 grs	304	442
Federal Hydra-Shok 124 grs	346	480	RWS Action 1 5.6g / 86 grs	420	495
Federal Hydra-Shok 147 grs	296	419	RWS PRN 8g	331	437
Fiocchi 100 grs FMJTCSP	401	522	Sako KPO 7.4 g	364	489
Fiocchi Subsonic 147 grs FMJHP	294	414	Samson 115 grs FMJ	363	493
Fiocchi Zero Pollution 123 grs	340	462	Samson DICUT 115 grs	371	514
Hirtenberger EMB 5.09g	463	545	SM RUAG 6.4 g SeCa	395	499
Hornady 147 grs XTP	289	398	SM RUAG Subsonic 147 grs BJHP	295	417
Hornady Custom XTP 124 grs	330	436	SM RUAG Swiss P 8 g FMJ	381	580
Hornady Custom XTP 115 grs	351	461	SM RUAG Swiss P Self 6.4 g	392	492
Hornady JHP/XTP 115 grs	339	429	Speer Gold Dot 115 grs GDHP	362	490
Hornady JHP/XTP 124 grs	335	450	Speer Gold Dot 124 grs GDHP	341	359
Hornady JHP/XTP 147 grs	287	394	Speer Gold Dot 147 grs GDHP (Los 1)	309	456
Magtech 115 grs JHP	356	475	Speer Gold Dot 147 grs GDHP (Los 2)	305	445
Magtech Clean Range 124 grs	348	483	Speer Lawman 115 grs FMJ	383	549
Magtech FMC 124 grs	326	426	Triton +P 147 grs BHP	348	580
Magtech FMC-Flat 9.52g / 147grs	303	436			
Magtech JSP-Flat 95 grs (Los 1)	400	493	UMC MC 147 gr	294	412
Magtech JSP-Flat 95 grs (Los 2)	402	499	Winchester Controlled Expans. 147 grs	294	414
MEN 9.5 g	325	501	Winchester Ranger 115 grs JHP	413	637
MEN QD1 5.79g/88grs	426	526	Winchester Silvertip 115grs	365	498
MEN QD2 97 grs	422	562	Winchester SXT 147 grs	295	416

All but not only the listed cartridges provide reliable weapon function.

5. Exploded views and parts lists

5.1 Exploded view MP9

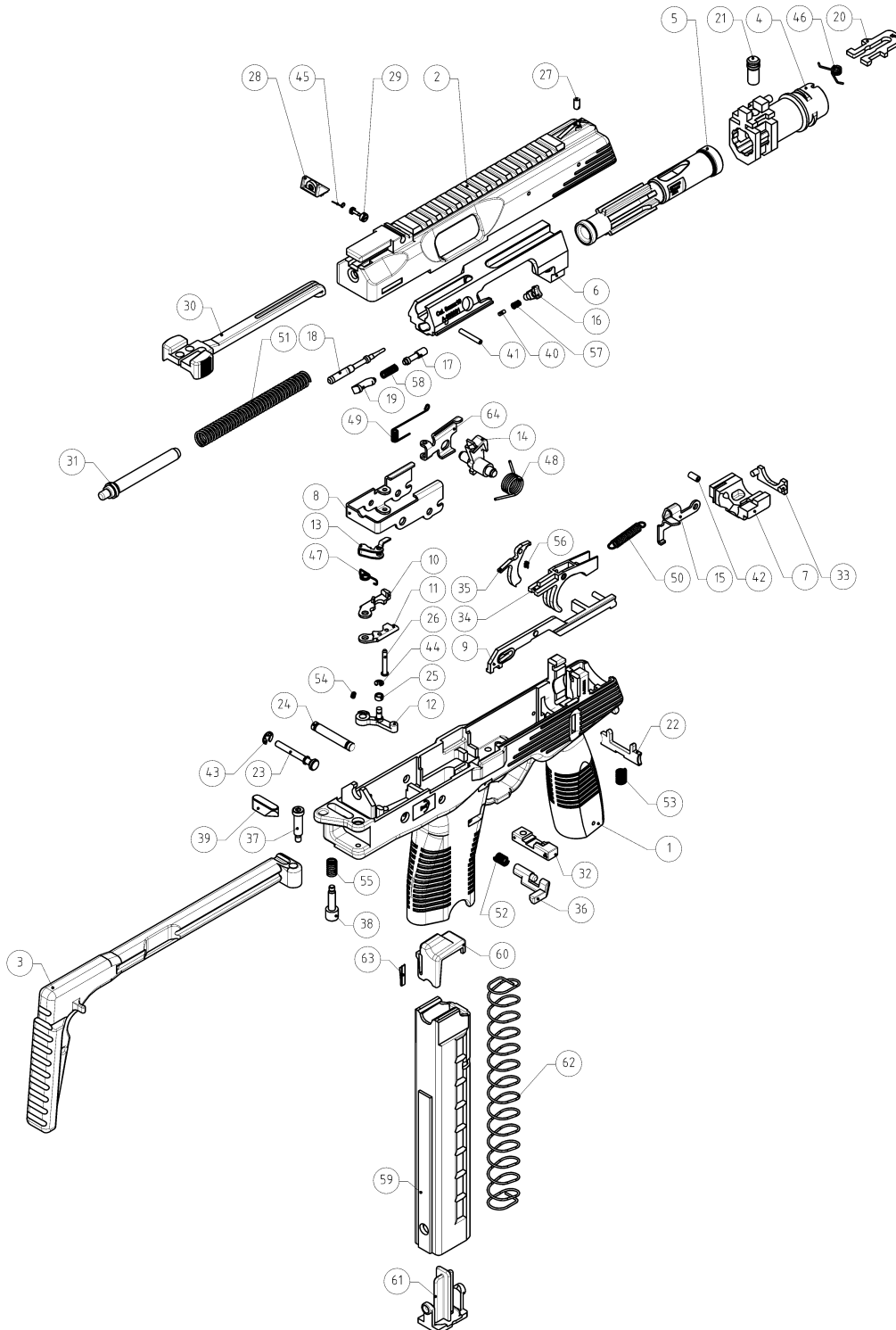

Fig. 5.1

5.2 Partslist MP9

Pos	Description	Part ID	Pos	Description	Part ID
1	Receiver, Empty	BT-30224	33	Buffer	BT-30134
2	Top Cover	BT-30235	34	Trigger	BT-30163
3	Folding Stock	BT-30234	35	Trigger Safety	BT-30265
4	Barrel Guide	BT-30227	36	Magazine Release	BT-30136
5	Barrel	BT-30226	37	Stock Pivot Pin	BT-30116
6	Bolt	BT-30230	38	Stock Release Knob	BT-30184
7	Ramp	BT-30203	39	Locking Bar	BT-30185
8	Trigger Housing	BT-30192	40	Shock Buffer	BT-30195
9	Sear Bar	BT-30146	41	Spiral pin Ø3x20	BT-30276
10	Sear	BT-30141	42	Spiral pin Ø4x8	BT-30275
11	Disconnecter	BT-30159	43	Washer lock Ø4	BT-30267
12	Control Lever	BT-30176	44	Washer lock Ø2.3	BT-30266
13	Drop Safety	BT-30194	45	Rear Sight Spring	BT-30168
14	Hammer	BT-30173	46	Detent Plate Spring	BT-30169
15	Bolt Release Lever	BT-30193	47	Sear Spring	BT-30210
16	Extractor	BT-30167	48	Hammer Spring	BT-30218
17	Extractor Plunger	BT-30165	49	Locking Sear Spring	BT-30219
18	Firing Pin	BT-30113	50	Trigger Spring	BT-30268
19	Connector	BT-30155	51	Recoil Spring	BT-30269
20	Detent Plate	BT-30126	52	Magazine Release Spring	BT-30270
21	Locking Pin	BT-30127	53	Latch Spring	BT-30271
22	Latch	BT-30148	54	Drop Safety Spring	BT-30272
23	Axle Pin	BT-30128	55	Folding Stock Spring	BT-30273
24	Trigger Pin	BT-30132	56	Trigger Safety Spring	BT-30274
25	Roller	BT-30133	57	Extractor Spring	BT-30198
26	Clevis Pin	BT-30199	58	Firing Pin Spring	BT-30277
27	Front Sight	BT-30149	59	Magazine Body 30 rds	BT-30180
28	Rear Sight / Ghost Ring	BT-30229	60	Magazine Follower	BT-30178
29	Adjusting Screw	BT-30151	61	Magazine Plate	BT-30177
30	Charging Handle	BT-30150	62	Magazine Spring	BT-30205
31	Guide Rod	BT-30156	63	Follower Spring	BT-30164
32	Fire Selector	BT-30147	64	Locking Sear	BT-30191

Note: Parts inventory varies for the different models. Indicate model and colour at order.

5.3 Exploded view TP9

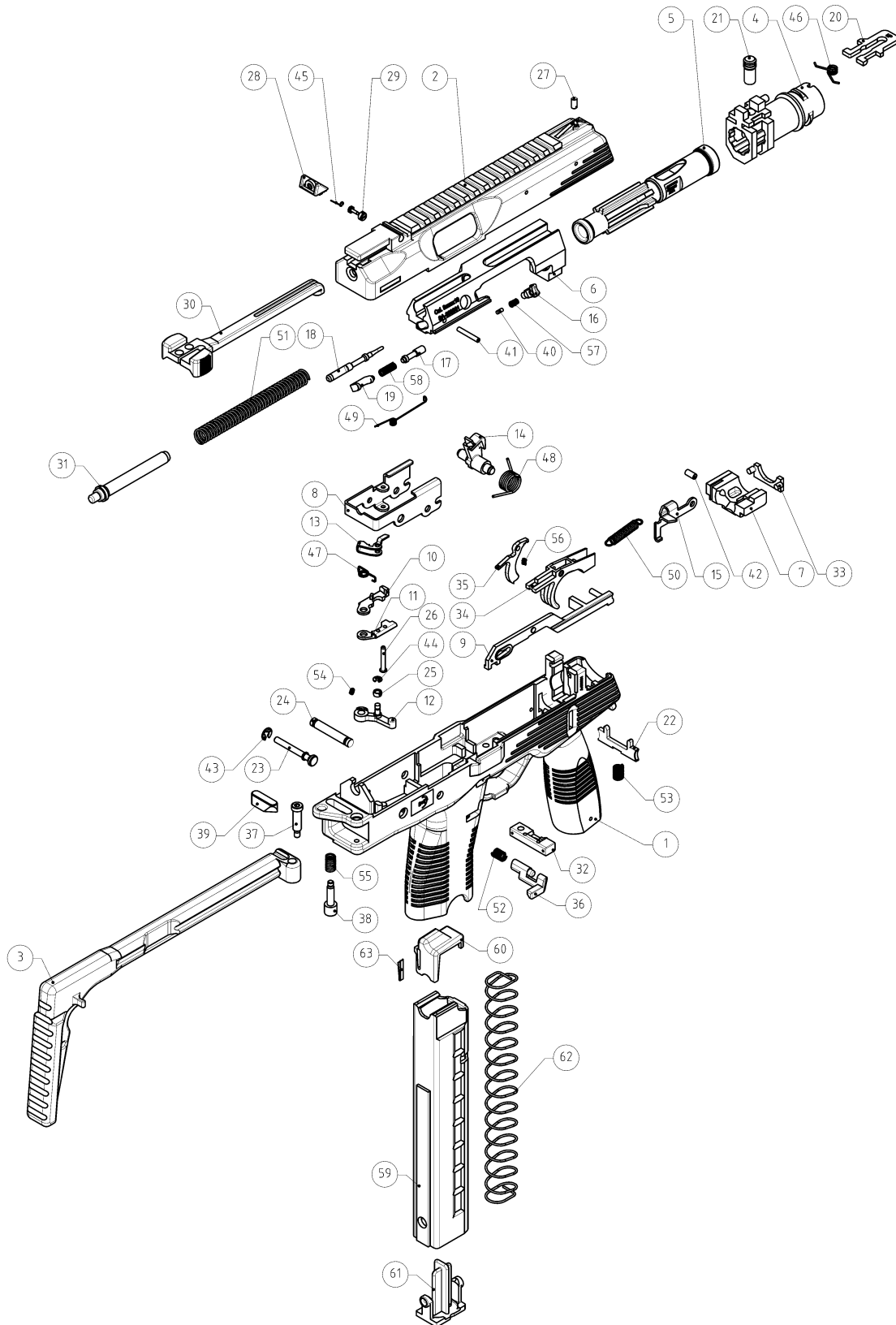

Fig. 5.2

5.4 Partslist TP9

Pos	Description	Part ID	Pos	Description	Part ID
1	Receiver, Empty	BT-30256	33	Buffer	BT-30134
2	Top Cover	BT-30235	34	Trigger	BT-30163
3	Folding Stock	BT-30234	35	Trigger Safety	BT-30265
4	Barrel Guide	BT-30227	36	Magazine Release	BT-30136
5	Barrel	BT-30226	37	Stock Pivot Pin	BT-30116
6	Bolt	BT-30258	38	Stock Release Knob	BT-30184
7	Ramp	BT-30203	39	Locking Bar	BT-30185
8	Trigger Housing	BT-30192	40	Shock Buffer	BT-30195
9	Sear Bar	BT-30146	41	Spiral pin Ø3x20	BT-30276
10	Sear	BT-30171	42	Spiral pin Ø4x8	BT-30275
11	Disconnecter	BT-30160	43	Washer lock Ø4	BT-30267
12	Control Lever	BT-30176	44	Washer lock Ø2.3	BT-30266
13	Drop Safety	BT-30194	45	Rear Sight Spring	BT-30168
14	Hammer	BT-30174	46	Detent Plate Spring	BT-30169
15	Bolt Release Lever	BT-30193	47	Sear Spring	BT-30210
16	Extractor	BT-30167	48	Hammer Spring	BT-30218
17	Extractor Plunger	BT-30165	49	Locking Sear Spring	BT-30222
18	Firing Pin	BT-30113	50	Trigger Spring	BT-30268
19	Connector	BT-30155	51	Recoil Spring	BT-30269
20	Detent Plate	BT-30126	52	Magazine Release Spring	BT-30270
21	Locking Pin	BT-30127	53	Latch Spring	BT-30271
22	Latch	BT-30148	54	Drop Safety Spring	BT-30272
23	Axle Pin	BT-30128	55	Folding Stock Spring	BT-30273
24	Trigger Pin	BT-30132	56	Trigger Safety Spring	BT-30274
25	Roller	BT-30133	57	Extractor Spring	BT-30198
26	Clevis Pin	BT-30199	58	Firing Pin Spring	BT-30277
27	Front Sight	BT-30149	59	Magazine Body 30 rds	BT-30180
28	Rear Sight / Ghost Ring	BT-30229	60	Magazine Follower	BT-30178
29	Adjusting Screw	BT-30151	61	Magazine Plate	BT-30177
30	Charging Handle	BT-30150	62	Magazine Spring	BT-30205
31	Guide Rod	BT-30156	63	Follower Spring	BT-30164
32	Safety Switch	BT-30135			

Note: Parts inventory varies for the different models. Indicate model and colour at order.

6. Accessories

6.1 Standard delivery

Standard delivery includes:

- Weapon with 15 rds magazin
- 30 rds magazine
- cleaning kit
- carrying sling
- hardcase
- operator manual



Fig. 6.1

6.2 Magazines

Capacity:	Part number:
15 rds magazine	BT-30209
20 rds magazine	BT-30296
25 rds magazine	BT-30298
30 rds magazine	BT-30183

6.3 Aimpoint reflex sight

Performance:

- Fast and sure target acquisition;
- doubles hit probability;
- compatible with nighvision devices.

Sight-in distance: 15 m recommended

Point-Blank-Range: 2 m to 100 m (for target dia. 100 mm)

Operation and maintenance: Refer to manufacturer manuals.



Fig. 6.2

6.4 Top Covers with Side Rails

Performance:

- Feature Picatinny Mil-Std 1913 rails on right side (fig. 6.2 with attached light module) or both left and right side;
- complete with iron sights

Part numbers:

BT-30300 with one siderail (right only)

BT-30358 with two siderails (right and left side). Note: Does not work with holsters in section 6.7!

6.5 Sound suppressor

Performance:

- Reduces muzzle flash;
- attachment for underbarrel laser/light module;
- sound reduction (see table below):

Ammunition:	w/o suppressor	w/ suppressor	Sound reduction
9x19 Standard	163.3 dB A	130.1 dB A	33.2 dB A
9x19 Subsonic	158.7 dB A	125.1 dB A	33.6 dB A

Part number: B&T SD-988401



Fig. 6.3

6.6 Brasscatcher

Brasscatcher (fig. 6.3) attaches to siderail topcovers. Recommended in sensitive environment such as vehicles.

Part number: BT-30110

6.7 Holsters

Duty Holster

Part numbers:

BT-30339R Right hand

BT-30339L Left hand



Fig. 6.4

High Ride Holster

Part numbers:

BT-30341R Right hand

BT-30341L Left hand



Fig. 6.5

Tactical Holster

Part numbers:

BT-30332R Right hand

BT-30332L Left hand



Fig. 6.6

6.8 Fix stock

The fix stock is a replacement to the regular folding stock. No permanent modifications to the weapon are required to install it.

Part number: BT-30189



Fig. 6.7

6.9 Training aids



Fig. 6.8

MP9-FX

Force on force training weapon for marking cartridges 9mm FX

Part number: BT-30106



Fig. 6.9

MP9-M

Inert, non-firing model for basic instruction or non-shooting scenario training.

Part number: BT-30289

6.10 Adaptor Light Laser

Provides additional interface for IT M3, M6 and similar laser light modules. Reduces muzzle flip as secondary effect.

Part number: BT-30120



Fig. 6.10

7. Manufacturer's warranty information

- a. The manufacturer's warranty covers the complete system with all genuine components and accessories.
- b. The warranty is valid three years from the date of acceptance of the weapon system by the customer's authority.
- c. The warranty is applicable on all non-conformities in material or workmanship detected during the period.