

Vapor Pressure of Organic Compounds. Measurement and Correlation

Květoslav Růžička, Michal Fulem, Vlastimil Růžička

Department of Physical Chemistry, Institute of Chemical Technology, 166 28 Prague 6, Czech Republic (kvetoslav.ruzicka@vscht.cz, vlastimil.ruzicka@vscht.cz)

List of content:

1. Introduction	1
2. Measurement of Vapor Pressure by a Static Method	2
3. Simple and Controlled Extrapolation of Vapor Pressures Towards the Triple Point	5
4. Thermodynamic Background of the Data Correlation	6
5. Compounds Studied in Our Laboratory	8
6. References	10
Květoslav Růžička & Vlastimil Růžička. List of papers 1994-2004	12

1. Introduction

The vapor-liquid saturation line in a diagram of pressure versus temperature is the main characteristic of the vaporization equilibrium for a one-component system. The vapor pressure p_{sat} is one of the most frequently measured thermodynamic properties for pure organic liquids, and the normal boiling temperature T_b is a basic physicochemical parameter for any substance. Vapor pressure data p_{sat} are needed for a variety of chemical engineering and thermodynamic calculations. Importance of vapor pressure data, in particular for high-boiling organic compounds, became even more evident over the last several decades with raising awareness of the environmental impact of pollutants.

The experimental determination of vapor pressure is relatively easy in the range between 1 and 200 kPa which is usually denoted as a moderate (or medium) pressure region. Most published data have been reported between 5 and 100 kPa and many reliable results are available. The best accuracy can be achieved near the normal boiling temperature; the high quality data measured close to atmospheric pressure have an error below 0.01 percent. Several

compilations were published over the last 30 years (e.g. ¹⁻⁸) that present experimental and/or recommended data for a large quantity of compounds.

Measurements become difficult at low pressures (say $p_{\text{sat}} < 1$ kPa); data are available only for a limited number of substances and often subject to large systematic errors. Differences in reported values usually amount to several tens of percent near the triple point temperature. Various approaches to experimental determination of vapor pressures were reviewed ^{9,10}. The main experimental techniques for determination of vapor pressures in the low-pressure region are the saturation method using a carrier gas and two techniques based on molecular effusion (weighing effusion and torsion effusion methods). Gas-liquid chromatography has also been used, but it is not easy to give the resulting data a rigorous thermodynamic interpretation. Direct static measurement of vapor pressure is a universal technique that can be used over a wide pressure range down to, or in special cases even below, 1 Pa; the most accurate data reported in the low-pressure region were obtained by this technique.

2. Measurement of Vapor Pressure by a Static Method

In our laboratory two recently constructed static apparatuses are available. Static method allows measurement of vapor pressure in the liquid as well in the solid phases over a wide range of temperatures including room temperature. As the inner volume of the apparatuses is evacuated to pressure of about 10^{-5} Pa and the apparatus is regularly checked for tightness by a helium leak detector the static apparatuses allow measurement with compounds sensitive to oxygen and water. In the next two sections the apparatuses and their most recent improvements are described in some more details and the preparation of samples for vapor pressure measurement is discussed.

Apparatus for the vapor pressure measurement

Two static apparatuses internally denoted as STAT3 and STAT4 (see Fig. 1 and Fig. 2, respectively) were recently built in our laboratory. Working ranges of apparatuses STAT3 and STAT4 are given in Table 1.

Apparatus	Pressure range	Temperature range	Accuracy in pressure	Accuracy in temperature
STAT3	0.1 Pa to 13 kPa	40 to 200 °C	0.2 % (0.1-13 kPa) 1 % (10-100 Pa) 3 % (1-10 Pa) 10 % (0.1-1 Pa)	0.02 °C
STAT4	0.1 Pa to 1.3 kPa	-50 to 40 °C	0.05 %	0.02 °C

Both apparatuses are constructed of 1/4" stainless steel internally electrochemically polished tubing with VCR fittings and NUPRO valves (Swagelok Co., USA). Valves taking

control of measuring procedure are computer controlled using HP-VEE program and servo PPN2 (Ekorex, Czech Republic). Pressure is measured by capacitance diaphragm MKS pressure gauges (MKS Baratron™ 616A11TRC-S and MKS Baratron™ 690A11TRA, respectively, MKS Instruments Inc., USA) and sample temperature is measured by the platinum resistance thermometers Burns Engineering 12001-A-12-6-2-A (Burns Engineering Inc., USA) in a four-wire connection. The thermometers Burns Engineering are calibrated at the ice point and/or by comparison to standard platinum resistance thermometer (SPRT). This SPRT is calibrated to the ITS-90 and its calibration is traceable to the National Institute of Standards and Technology (NIST). The accuracy of the measurement of sample temperature is very important and is estimated to be better than 0.02 K. In the case of STAT3 the sample temperature is controlled by metal thermostat built in our laboratory and in the case of STAT4 by liquid thermostat Lauda RK 8 CP (Lauda, Germany). Stability of the sample temperature is within 0.02°C in both cases.

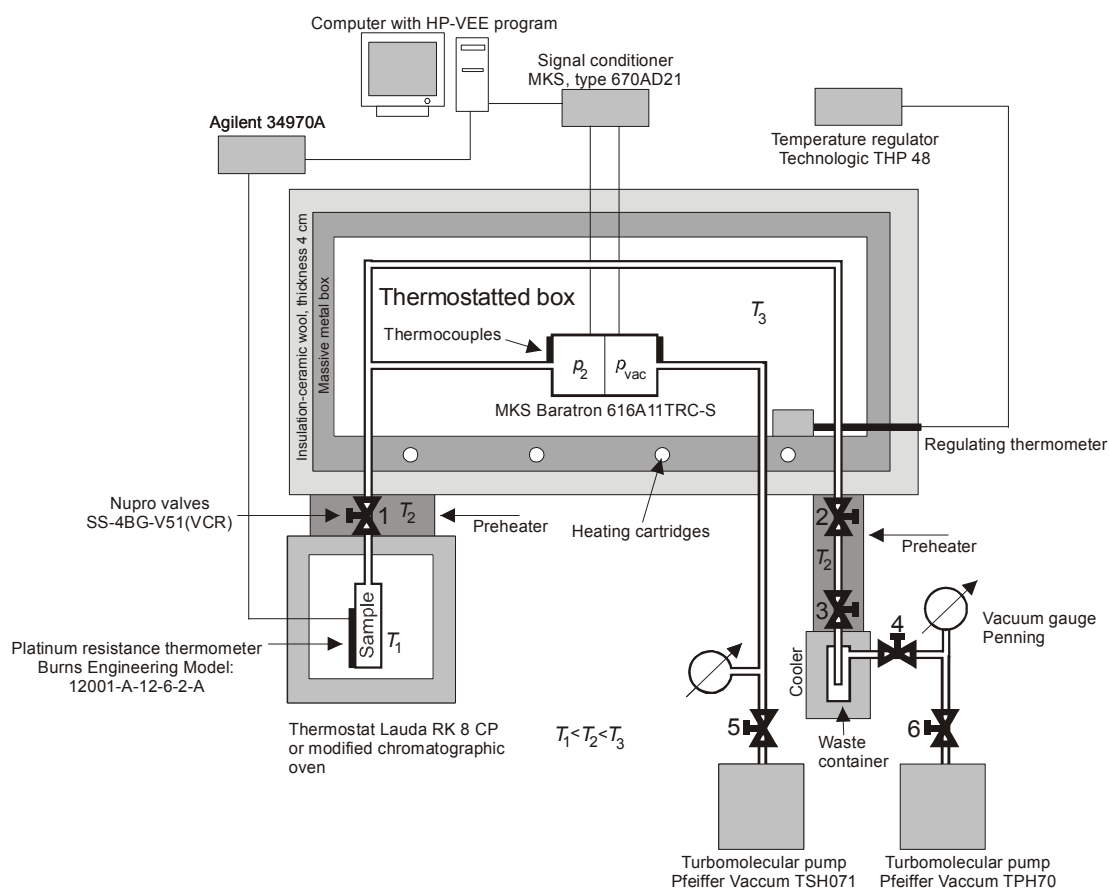

Fig. 1 Apparatus STAT3 for the measurement of vapor pressure. Valve 1 is the container valve; valves 2 and 3 are computer controlled. Valves 3-6 serve for the maintenance of the apparatus.

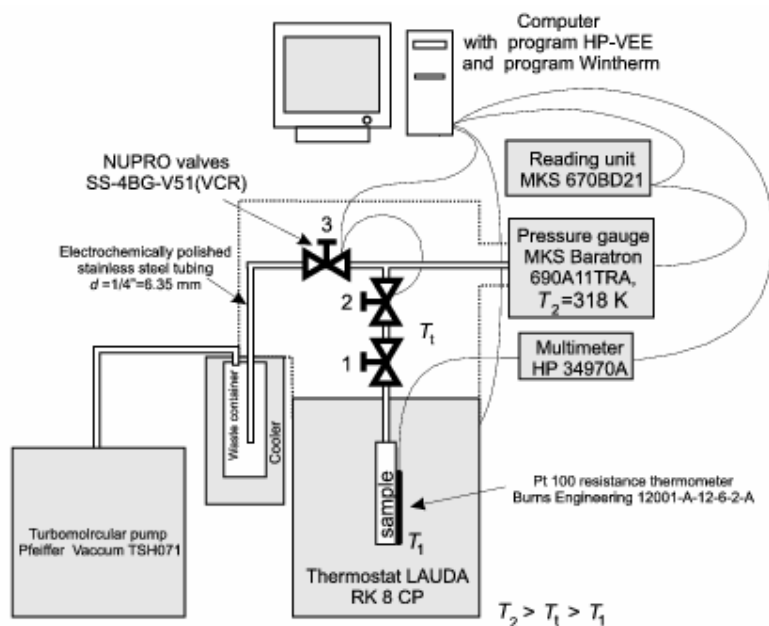

Fig. 2 Apparatus STAT4 for the measurement of vapor pressure. Valve 1 is the container valve; valves 2 and 3 are computer controlled.

Prior to measurement of vapor pressure the apparatuses are checked for tightness by MKS PICO™ vacuum leak detector (MKS Instruments Inc., USA). The apparatuses are evacuated between individual measurement cycles by turbomolecular pumps to a pressure of 10^{-5} Pa. A computer using HP-VEE program monitors the pressure, the temperature of the sample, preheater and thermostatted box (see Fig. 1) and controls the measuring procedure. Experiments are carried out in the given temperature interval by varying the temperature at random in order to avoid systematic errors caused by possible decomposition or insufficient degassing of the sample.

Preparation of samples prior to vapor pressure measurement

Generally, there are two steps in preparation of samples for vapor pressure measurement by a static method. Firstly, since vapor pressure is very sensitive to sample impurities it is often necessary to purify and dry the sample. Secondly, the samples must be perfectly degassed. This step is a prerequisite for correct vapor pressure measurement by a static method. Several methods of degassing are known: the method based on repeated freeze-pump-melt cycles¹¹, degassing using ultrasound, distillation, etc. We developed a new method, which allows handling of compounds without any risk of contamination and loss of the sample during degassing procedure. The method is based on using a semi permeable membrane (e.g. made of polydimethylsiloxan or polyvinyltrimethylsilan) which is permeable only for low molecular weight gases (oxygen, nitrogen, etc.) but not for the sample molecules. This membrane is placed between the sample cell and the vacuum pump to avoid loss of the sample when it is pumped out by a vacuum pump; pressure is maintained at or below 1 Pa. This method proved to be very efficient and easy when using a simple vacuum apparatus.

3. Simple and Controlled Extrapolation of Vapor Pressures Towards the Triple Point

The simplest approach to obtain vapor pressure data in the low-pressure region is an extrapolation from vapor pressures measured in the medium pressure region using an equation with an optimum number of parameters. The input data must be reliable and available over a sufficiently wide temperature interval in order to allow a meaningful extrapolation. The form of the correlation equation used can also largely affect the results.

An alternative approach regarding extrapolation towards low pressures is a combination of p_{sat} in the medium pressure region with the related thermal data by which we understand enthalpy of vaporization ΔH_{vap} and the heat capacity difference $\Delta C_{\text{vap}}^{\circ}$. The latter quantity is defined as

$$\Delta C_{\text{vap}}^0 = C_p^{g0} - C_p^l \quad (1)$$

where C_p^{g0} denotes the heat capacity of an ideal gas and C_p^l that of the liquid. Vapor pressures are related to the thermal properties by the exact thermodynamic relationships, which allow a controlled extrapolation of p_{sat} data in the medium-pressure region down to the triple-point temperature T_t , provided the thermal data are available in the temperature range below that of the p_{sat} data. In extrapolations, enthalpies of vaporization cannot always be used effectively, as reliable calorimetric values at temperatures corresponding to p_{sat} in the low-pressure region are available only for a limited number of compounds. On the other hand, heat capacity differences are more readily accessible since they can be calculated for many compounds in a wide temperature range down to the triple-point temperature by combining calorimetric and spectroscopic data. The simultaneous correlation of medium vapor pressures and $\Delta C_{\text{vap}}^{\circ}$ values can also be useful for determining the frequently required values of ΔH_{vap} at 298.15 K for high boiling compounds. Further combination of the vapor pressure calculated at T_t with the enthalpies of phase transition (solid-liquid, solid-solid) and differences between the heat capacity of an ideal gas and that of the solid makes it possible to calculate vapor pressures along the vapor-solid saturation line.

The method using the thermal data for extrapolating vapor pressures was first described by King and Al-Najjar¹², and further developed by Ambrose and Davies¹³ and Růžička and Majer¹⁴. Thermodynamic background of the method of multi-property simultaneous correlation of vapor pressure and related thermal data is described in the part 3.

Růžička and Majer¹⁵ tested several most frequently used equations for correlating temperature dependence of vapor pressure. The Antoine equation

$$\ln p_{\text{sat}} = A_1 - \frac{A_2}{T + A_3} \quad (2)$$

clearly shows the poorest performance; it fails for most types of compounds both in simple and controlled extrapolation and is not even able to describe adequately the p_{sat} data in the medium-pressure region for compounds with specific interactions. The Antoine equation has a very low flexibility and its use should always be abandoned when the temperature interval of correlation becomes large (say above 50 K) and any kind of extrapolation is foreseen. The only effective

way of using the Antoine equation is determination of two (or more) parameter sets, corresponding to different temperature intervals, with forced continuity of p_{sat} and its first temperature derivative at the boundaries (TRC Thermodynamic Tables^{6,7}).

The Wagner equation¹⁶

$$\ln\left(\frac{p_{\text{sat}}}{p_c}\right) = \frac{T_c}{T} \sum_{i=1}^m A_i \left(1 - \frac{T}{T_c}\right)^{\alpha_i} \quad (3)$$

requires the use of critical parameters that provide for the realistic prediction of the vapor pressure saturation line up to the critical temperature. However, this constraint limits the flexibility of the relationship in low-pressure extrapolations and is both useless and inconvenient for high boiling chemicals that decompose below or near the normal boiling temperature. The number of adjustable parameters in equation (3) is usually four; five adjustable parameters were used exceptionally for correlations of accurate data in a wide temperature range. In all versions of the Wagner equation the first exponent α_1 is equal to 0. The four-parameter forms with either $\alpha_2=1, \alpha_3=2, \alpha_4=5$ or $\alpha_2=1.5, \alpha_3=3, \alpha_4=6$ have been used most often.

The Cox equation¹⁷

$$\ln\left(\frac{p_{\text{sat}}}{p_o}\right) = \left(1 - \frac{T_o}{T}\right) \exp\left(\sum_{i=0}^n A_i T^i\right) \quad (4)$$

can be considered to be the most useful equations for extrapolations toward low pressures; the possibility of changing both the number of parameters and the reference condition T_o and p_o allows one to obtain different forms suitable for particular applications. The three-parameter form with the normal boiling point ($T_o=T_b$ and $p_o=101,325$ kPa) is very dependable in both simple and controlled extrapolation for all organic liquids with the exception of hydrogen-bonded compounds. In the latter case, the four-parameter equation gives very good results for extrapolation when vapor pressures and the thermal data are fitted simultaneously. For compounds decomposing below the normal boiling temperature, a vapor pressure corresponding to a lower temperature can always be used as a reference condition. On the other hand, the use of the critical point allows one to transform the Cox equations into a relationship suitable for description of the complete vapor pressure line. The four-parameter form with reference conditions T_c and p_c is comparable to the Wagner equation and behaves similarly in correlation and extrapolation toward low pressures. The Wagner equations require the use of critical parameters that provide for the realistic prediction of the vapor-pressure saturation line up to the critical temperature. However, this constraint limits the flexibility of the relationship in low-pressure extrapolations and is both useless and inconvenient for high boiling chemicals that decompose below or near the normal boiling temperature.

4. Thermodynamic Background of the Data Correlation

Thermodynamic background for the temperature correlation of vapor pressures and the related thermal data has been described in the literature (Majer et al.,¹⁸; Růžička and Majer,¹⁹) and will be reviewed only briefly here. The parameters of a selected correlation equation can be determined by minimizing a general objective function:

$$S = \sum_{i=1}^t \frac{(\ln p_{\text{sat}}^{\text{exp}} - \ln p_{\text{sat}}^{\text{sm}})_i^2}{\sigma_i^2 \ln p_{\text{sat}}} + K_H^2 \sum_{j=1}^u \frac{(\Delta H'_j{}^{\text{exp}} - \Delta H'_j{}^{\text{sm}})^2}{\sigma_j^2 \Delta H'_j} + K_C^2 \sum_{k=1}^v \frac{(\Delta C'_k{}^{\text{exp}} - \Delta C'_k{}^{\text{sm}})^2}{\sigma_k^2 \Delta C'_k} \quad (5)$$

The three individual sums correspond to the contribution of vapor pressures, enthalpies of vaporization, and heat capacity differences; indices t , u , v indicate the number of data points for each property. In the case when $u = v = 0$, the preceding equation reduces to the common formula for the weighted least squares fitting of vapor pressures alone; K_H , K_C are the factors allowing one to modify the weight of the thermal properties in the correlation; their values differ from unity when the number of data points for individual properties is disproportional or when some data inconsistency is observed. The variances $\sigma^2 \ln p_{\text{sat}}$, $\sigma_i^2 \Delta H'_i$, $\sigma_i^2 \Delta C'_i$ are estimated from the expected errors of experimental data points

The quantities with the superscript "sm" are expressed from the selected vapor pressure equation ($p_{\text{sat}}^{\text{sm}}$); the quantities $\Delta H'^{\text{sm}}$ and $\Delta C'^{\text{sm}}$ are given by equations

$$\Delta H' = R T^2 \left(\frac{d \ln p}{dT} \right)_{\text{sat}} \quad (6)$$

$$\Delta C' = \left(\frac{d \Delta H'}{dT} \right)_{\text{sat}} = R \left[\frac{d}{dT} T^2 \left(\frac{d \ln p}{dT} \right) \right]_{\text{sat}} \quad (7)$$

The quantities with the superscript "exp" relate to experimental vapor pressures ($p_{\text{sat}}^{\text{exp}}$); and thermal data. $\Delta H'^{\text{exp}}$ and $\Delta C'^{\text{exp}}$ can be calculated from ΔH_{vap} and $\Delta C^{\circ}_{\text{vap}}$ as follows:

$$\Delta H' = \frac{\Delta H}{1 + \frac{p_{\text{sat}}}{RT} (B - V^1)} \quad (8)$$

$$\Delta C' = \Delta C^{\circ}_{\text{vap}} - T p_{\text{sat}} \frac{d^2 B}{dT^2} - 2T \frac{d(B - V^1)}{dT} \left(\frac{dp}{dT} \right)_{\text{sat}} - T (B - V^1) \left(\frac{d^2 p}{dT^2} \right)_{\text{sat}} \quad (9)$$

where B is the second virial coefficient and the pressure dependence of the molar volume V^1 is neglected. For ideal gas behavior, $\Delta H'$ and $\Delta C'$ are equal to ΔH_{vap} and $\Delta C^{\circ}_{\text{vap}}$, respectively. This means that at sufficiently low pressures the primed quantities and the thermal data are practically identical and the importance of the pVT correction terms is increasing with increasing vapor pressure. At the normal boiling temperature, the quantities $\Delta H'$ and $\Delta C'$ differ from ΔH_{vap} and $\Delta C^{\circ}_{\text{vap}}$ typically by about 5 and 40 %, respectively. The possibilities of accurately determining the pVT correction terms in Eqs. 8 and 9 are limited for most compounds. In order to avoid distortion of the correlation through uncertainty in estimating the vapor nonideality, it is necessary to confine thermal data to the region where correction terms are not important, that is, $T < T_b - 40$ and $T < T_b - 80$ for ΔH_{vap} and $\Delta C^{\circ}_{\text{vap}}$, respectively.

The simultaneous treatment of vapor pressures and the related thermal data requires that reliable data are available for the respective properties. The data availability has been substantially facilitated over the last few decades by the publication of several comprehensive compilations listing the evaluated data for thermal properties in the form of correlating equations. Calorimetric enthalpies of vaporization were compiled and the recommended data produced for over 650 compounds by Majer and Svoboda²⁰, and experimental heat capacities of

liquid were evaluated and correlated as a function of temperature for more than 2000 compounds by Záborský et al.^{21,22}. Frenkel et al.²³ evaluated ideal gas properties for over 2000 organic compounds and reported recommended values of C_p^{g0} . Bureš et al.²⁴ published a temperature correlation of thermodynamic properties of ideal gas (including spectroscopic C_p^{g0} values) for 3000 organic compounds.

5. Compounds Studied in Our Laboratory

Several families of compounds have been studied so far in our laboratory. A survey of compounds measured with respective references is given in the table.

In several cases we have collaborated with other laboratories where complementary techniques are available. These include E. Hála Laboratory of Thermodynamics, Institute of Chemical Process Fundamentals, Academy of Sciences of the Czech Republic (*ebulliometry*, Karel AIM), Laboratoire d'Instrumentation et de Chimie Analytique en Solution, Université Claude Bernard, 69622 Villeurbanne, France (*static method*, Jacques JOSE, Ilham MOKBEL), Department of Chemistry, Belarusian State University, Minsk, Belarus (*Knudsen effusion method*, Dzmitry H. ZAITSAU, Gennady J. KABO), University of Porto, Faculty of Science, Department of Chemistry, Porto, Portugal (*Knudsen effusion method*, Manuel Joao S. MONTE), Laboratoire de Thermodynamique des Solutions et des Polymères, Université Blaise Pascal, Aubière, France (*calorimetric measurements*, Vladimír MAJER), Institute of Physical Chemistry, Faculty of Chemistry and Physics, Technical University - Bergakademie Freiberg, Freiberg/Sachsen, Federal Republic of Germany (*calorimetric measurements*, H.-G. SCHMIDT, Gert WOLF).

Survey of compounds studied in our lab (vapor pressure measurement was performed in all cases)

Family	Compounds	References	Note
Chlorobenzenes	di-, tri-, penta-chlorobenzenes	Roháč et al. ²⁵	Correlation of own and literature data by SimCor ^a , recommended data
High-boiling and poly-condensed compounds of petroleum interest	phenanthrene, pyrene, benzo[a]pyrene, 1,2,3,4-tetrahydronaphthalene, acenaphthene, 1,2-dihydronaphthalene, dibenzothiophene, 1-phenyldodecane, (5 α)-cholestane, adamantane	Růžička et al. ²⁶ , Mokbel et al. ²⁷	Correlation of own and literature data by SimCor, recommended data from 220 to almost 600 K
Esters of phthalic acid	dimethyl-, diethyl-phthalate	Roháč et al. ^{28,29}	Correlation of own and literature data by SimCor, recommended data
Compounds of pharmaceutical interest	perhydroacenaphthylene, perhydrophenanthrene	Roháč et al. ³⁰	Only vapor pressure data determined by ebulliometry
Metal-organic compounds	diethylzinc, triethylantimony, trimethylgallium, trimethylaluminum, Y(thd) ₃ and Zr(thd) ₄ ^b , trimethylindium	Fulem et al. ³¹⁻³³	Only vapor pressure data determined by static method

^a SimCor = multi-property simultaneous correlation of vapor pressure and related thermal data

^b thd=2,2,6,6-tetramethylheptane-3,5-dionate

6. References

- [1] Ohe, S. *Computer Aided Data Book of Vapor Pressures*, Chem.Soc.Japan: Tokyo, 1976.
- [2] Boublik, T.; Fried, V. Hála, E. *The Vapour Pressures of Pure Substances*, Elsevier: Amsterdam, 1984.
- [3] Dykyj, J.; Repáš, M. *Tlak nasytenej pary organických zlucenin (Vapour Pressure of Organic Compounds)*, Veda: Bratislava, 1979.
- [4] Dykyj, J.; Repáš, M. Svoboda, J. *Tlak nasytenej pary organických zlucenin (Vapour Pressure of Organic Compounds)*, Veda: Bratislava, 1984.
- [5] Daubert, T. E.; Danner, R. P. *Physical and Thermodynamic Properties of Pure Chemicals: Data Compilation*, Hemisphere Publishing Corp.: Bristol, Pennsylvania, USA, 1992.
- [6] *TRC Thermodynamic Tables. Hydrocarbons*, Thermodynamics Research Center, National Institute of Standards and Technology, Boulder, Colorado, 2004.
- [7] *TRC Thermodynamic Tables. Non-Hydrocarbons*, Thermodynamics Research Center, National Institute of Standards and Technology: Boulder, Colorado, 2004.
- [8] Poling, B. E.; Prausnitz, J. M. O'Connell, J. P. *Properties of Gases and Liquids*, McGraw-Hill Professional Publishing: 2000.
- [9] Ambrose, D. *Vapor pressure*, in *Experimental Thermodynamics of Non-reacting Systems*, **1975**, London, Butterworths.
- [10] Wahlbeck, P. G. Comparison and Interrelations for Four Methods of Measurement of Equilibrium Vapor Pressure at High Temperatures. *High Temp. Sci.* **1986**, *21*, 189-232.
- [11] Ambrose, D.; Lawrenson, I. J.; Sprake, C. H. S. The vapour pressure of naphthalene. *J. Chem. Thermodyn.* **1975**, *7*, 1173-1176.
- [12] King, M. B.; Al-Najjar, H. S. A method for correlating and extending vapour pressure data to lower temperatures using thermal data: vapour pressure equations for some n-alkanes at temperatures below the normal boiling point. *Chem. Eng. Sci.* **1974**, *29*, 1003
- [13] Ambrose, D.; Davies, R. H. The correlation and estimation of vapour pressures. III. Reference values for low-pressure estimations. *J. Chem. Thermodyn.* **1980**, *12*, 871-879.
- [14] Růžička, K.; Majer, V. A Simultaneous Correlation of Vapour Pressures and Thermal Data: Application to 1-alkanols. *Fluid Phase Equilib.* **1986**, *28*, 253-264.
- [15] Růžička, K.; Majer, V. Simple and Controlled Extrapolation of Vapor Pressures towards the Triple Point. *AIChE J.* **1996**, *42*, 1723-1740.
- [16] Wagner, W. New vapour pressure measurements for argon and nitrogen and a new method for establishing rational vapour pressure equations. *Cryogenics* **1973**, *13*, 470-483.
- [17] Cox, E. R. Hydrocarbon Vapor Pressure. *Ind. Eng. Chem.* **1936**, *28*, 613
- [18] Majer, V.; Svoboda, V. Pick, J. *Heats of Vaporization of Fluids*, Elsevier: Amsterdam, 1989.

- [19] Růžička, K.; Majer, V. Simultaneous Treatment of Vapor Pressures and Related Thermal Data Between the Triple and Normal Boiling Temperatures for n- Alkanes C5-C20. *J. Phys. Chem. Ref. Data* **1994**, *23*, 1-39.
- [20] Majer, V.; Svoboda, V. *Enthalpies of Vaporization of Organic Compounds, Critical Review and Data Compilation*, Blackwell: Oxford, 1985.
- [21] Zábanský, M.; Růžička, V.; Majer, V.; Domalski, E. S. *Heat Capacity of Liquids. Critical Review and Recommended Values*, J.Phys.Chem.Ref.Data Monograph No. 6, American Chemical Society: Washington, D.C., 1996.
- [22] Zábanský, M.; Růžička, V.; Domalski, E. S. Heat Capacity of Liquids: Critical Review and Recommended Values. Supplement I. *J. Phys. Chem. Ref. Data* **2001**, *30*, 1199-1689.
- [23] Frenkel, M. L.; Kabo, G. J.; Marsh, K. N.; Roganov, G. N. Wilhoit, R. C. *Thermodynamics of Organic Compounds in the Gas State*, TRC, TAMUS: College Station, Texas, 1994.
- [24] Bureš, M.; Holub, R.; Leitner, J. Vonka, P. *Termochemické velicíny organických sloučenin (Thermochemical properties of organic compounds)*, Institute of Chemical Technology, Prague, 1992.
- [25] Roháč, V.; Růžička, V.; Růžička, K.; Poledníček, M.; Aim, K.; Jose, J.; Zábanský, M. Recommended Vapour and Sublimation Pressures and Related Thermal Data for Chlorobenzenes. *Fluid Phase Equilib.* **1999**, *157*, 121-142.
- [26] Růžička, K.; Mokbel, I.; Majer, V.; Růžička, V.; Jose, J.; Zábanský, M. Description of vapour-liquid and vapour-solid equilibria for a group of polycondensed compounds of petroleum interest. *Fluid Phase Equilib.* **1998**, *148*, 107-137.
- [27] Mokbel, I.; Růžička, K.; Majer, V.; Růžička, V.; Ribeiro, M.; Jose, J.; Zábanský, M. Phase equilibria for three compounds of petroleum interest: 1-phenyldodecane, (5 α)-cholestane, adamantane. *Fluid Phase Equilib.* **2000**, *169*, 191-207.
- [28] Roháč, V.; Musgrove, J. E.; Růžička, K.; Růžička, V.; Zábanský, M.; Aim, K. Thermodynamic properties of dimethyl phthalate along the (vapour+liquid) saturation curve. *J. Chem. Thermodyn.* **1999**, *31*, 971-986.
- [29] Roháč, V.; Růžička, K.; Růžička, V.; Zaitsau, D. H.; Kabo, G. J.; Diky, V. V.; Aim, K. Vapour pressure of diethyl phthalate. *J. Chem. Thermodyn.* **2004**, *36*, 929-937.
- [30] Roháč, V.; Čenský, M.; Zala, D.; Růžička, V.; Růžička, K.; Sporka, K.; Aim, K. Vapour pressure and liquid heat capacity of perhydroacenaphthylene and perhydrophenanthrene. *J. Chem. Eng. Data* **2000**, *45*, 1205-1210.
- [31] Fulem, M.; Růžička, K.; Růžička, V.; Hulicius, E.; Šimeček, T.; Melichar, K.; Pangrác, J.; Rushworth, S. A.; Smith, L. M. Vapour pressure of metal organic precursors. *J. Crystal. Growth* **2003**, *248*, 99-107.
- [32] Fulem, M.; Růžička, K.; Růžička, V.; Šimeček, T.; Hulicius, E.; Pangrác, J. Vapour pressure and heat capacities of metal organic precursors, Y(thd)₃ and Zr(thd)₄. *J. Crystal. Growth* **2004**, *264*, 192-200.
- [33] Fulem, M.; Růžička, K.; Růžička, V.; Hulicius, E.; Šimeček, T.; Pangrác, J.; Rushworth, S. A.; Smith, L. M. Measurement of vapour pressure of In based metalorganics for MOVPE. *J. Crystal. Growth* **2004**,

Květoslav Růžička & Vlastimil Růžička. List of papers 1994-2004

- (1) Fulem, M.; Růžička, K.; Růžička, V.; Hulicius, E.; Šimeček, T.; Pangrác, J.; Rushworth, S. A.; Smith, L. M. Measurement of vapour pressure of In based metalorganics for MOVPE. *J. Crystal. Growth* **2004**,
- (2) Fulem, M.; Růžička, K.; Růžička, V.; Šimeček, T.; Hulicius, E.; Pangrác, J. Vapour pressure and heat capacities of metal organic precursors, Y(thd)3 and Zr(thd)4 . *J. Crystal. Growth* **2004**, *264*, 192-200.
- (3) Roháč, V.; Růžička, K.; Růžička, V.; Zaitsau, D. H.; Kabo, G. J.; Diky, V. V.; Aim, K. Vapour pressure of diethyl phthalate. *J. Chem. Thermodyn.* **2004**, *36*, 929-937.
- (4) Růžička, K.; Fulem, M.; Růžička, V.; Zábanský, M. Heat capacities of alkanols III. Some 1-alkanols from C10 to C20. *Thermochim. Acta* **2004**, *421*, 35-41.
- (5) Čenský, M.; Růžička, K.; Růžička, V.; Zábanský, M. Heat Capacities of Alkanols: II. Some Isomeric C5 Alkanols. *Thermochim. Acta* **2003**, *408*, 45-53.
- (6) Fulem, M.; Růžička, K.; Růžička, V.; Hulicius, E.; Šimeček, T.; Melichar, K.; Pangrác, J.; Rushworth, S. A.; Smith, L. M. Vapour pressure of metal organic precursors. *J. Crystal. Growth* **2003**, *248*, 99-107.
- (7) Fulem, M.; Růžička, K.; Růžička, V. Heat capacities of alkanols Part I. Selected 1-alkanols C₂ to C₁₀ at elevated temperatures and pressures. *Thermochim. Acta* **2002**, *382*, 119-128.
- (8) Lipovská, M.; Schmidt, H.-G.; Roháč, V.; Růžička, V.; Wolf, G.; Zábanský, M. Heat capacities of three isomeric chlorobenzenes and of three isomeric chlorophenols. *J. Therm. Anal. Cal.* **2002**, *68*, 753-766.
- (9) Roháč, V.; Fulem, M.; Schmidt, H.-G.; Růžička, V.; Růžička, K.; Wolf, G. Heat capacities of some phthalate esters. *J. Therm. Anal. Cal.* **2002**, *70*, 455-466.
- (10) Zábanský, M.; Růžička, V. Heat Capacity of Liquids. Critical Review. *Fluid Phase Equilib.* **2002**, *194-197*, 817-824.
- (11) Čenský, M.; Lipovská, M.; Schmidt, H.-G.; Růžička, V.; Wolf, G. Heat capacities of hydroxy and aminoderivatives of benzene. *J. Therm. Anal. Cal.* **2001**, *63*, 879-899.
- (12) Zábanský, M.; Růžička, V.; Domalski, E. S. Heat Capacity of Liquids: Critical Review and Recommended Values. Supplement I. *J. Phys. Chem. Ref. Data* **2001**, *30*, 1199-1689.
- (13) Mokbel, I.; Růžička, K.; Majer, V.; Růžička, V.; Ribeiro, M.; Jose, J.; Zábanský, M. Phase equilibria for three compounds of petroleum interest: 1-phenyldodecane, (5 α)-cholestane, adamantane. *Fluid Phase Equilib.* **2000**, *169*, 191-207.
- (14) Roháč, V.; Čenský, M.; Zala, D.; Růžička, V.; Růžička, K.; Sporka, K.; Aim, K. Vapour pressure and liquid heat capacity of perhydroacenaphthylene and perhydrophenanthrene. *J. Chem. Eng. Data* **2000**, *45*, 1205-1210.
- (15) Roháč, V.; Musgrove, J. E.; Růžička, K.; Růžička, V.; Zábanský, M.; Aim, K. Thermodynamic properties of dimethyl phthalate along the (vapour+liquid) saturation curve. *J. Chem. Thermodyn.* **1999**, *31*, 971-986.
- (16) Roháč, V.; Růžička, V.; Růžička, K.; Poledníček, M.; Aim, K.; Jose, J.; Zábanský, M. Recommended Vapour and Sublimation Pressures and Related Thermal Data for Chlorobenzenes. *Fluid Phase Equilib.* **1999**, *157*, 121-142.
- (17) Roháč, V.; Jose, J.; Poledníček, M.; Růžička, V. Sublimation pressures and vapor pressures of dichlorobenzenes (1, 2-, and 1,3) and trichlorobenzene (1,2,4-). *ELDATA: Int. Electron. J. Phys.-Chem. Data* **1998**,
- (18) Roháč, V.; Růžička, V.; Růžička, K.; Aim, K. Measurements of Saturated Vapor Pressure above the Liquid Phase for Isomeric Dichlorobenzenes and 1,2,4-Trichlorobenzene. *J. Chem. Eng. Data* **1998**, *43*, 770-775.
- (19) Růžička, K.; Mokbel, I.; Majer, V.; Růžička, V.; Jose, J.; Zábanský, M. Description of vapour-liquid and vapour-solid equilibria for a group of polycondensed compounds of petroleum interest. *Fluid Phase Equilib.* **1998**, *148*, 107-137.

- (20) Růžička, K.; Majer, V. Simple and Controlled Extrapolation of Vapor Pressures towards the Triple Point. *AIChE J.* **1996**, *42*, 1723-1740.
- (21) Růžička, K.; Majer, V. Simultaneous Treatment of Vapor Pressures and Related Thermal Data Between the Triple and Normal Boiling Temperatures for n- Alkanes C5-C20. *J. Phys. Chem. Ref. Data* **1994**, *23*, 1-39.
- (22) Růžička, V.; Zábanský, M.; Růžička, K.; Majer, V. Vapor pressures for a group of high-boiling alkylbenzenes under environmental conditions. *Thermochim. Acta* **1994**, *245*, 121-144.