

# ISS and STS Commercial Off-The-Shelf Router Testing

William D. Ivancic  
Glenn Research Center, Cleveland, Ohio

Terry L. Bell  
Lockheed Martin Global Telecommunications, Cleveland, Ohio

Dan Shell  
Cisco Systems, San Jose, California

## The NASA STI Program Office . . . in Profile

Since its founding, NASA has been dedicated to the advancement of aeronautics and space science. The NASA Scientific and Technical Information (STI) Program Office plays a key part in helping NASA maintain this important role.

The NASA STI Program Office is operated by Langley Research Center, the Lead Center for NASA's scientific and technical information. The NASA STI Program Office provides access to the NASA STI Database, the largest collection of aeronautical and space science STI in the world. The Program Office is also NASA's institutional mechanism for disseminating the results of its research and development activities. These results are published by NASA in the NASA STI Report Series, which includes the following report types:

- **TECHNICAL PUBLICATION.** Reports of completed research or a major significant phase of research that present the results of NASA programs and include extensive data or theoretical analysis. Includes compilations of significant scientific and technical data and information deemed to be of continuing reference value. NASA's counterpart of peer-reviewed formal professional papers but has less stringent limitations on manuscript length and extent of graphic presentations.
- **TECHNICAL MEMORANDUM.** Scientific and technical findings that are preliminary or of specialized interest, e.g., quick release reports, working papers, and bibliographies that contain minimal annotation. Does not contain extensive analysis.
- **CONTRACTOR REPORT.** Scientific and technical findings by NASA-sponsored contractors and grantees.

- **CONFERENCE PUBLICATION.** Collected papers from scientific and technical conferences, symposia, seminars, or other meetings sponsored or cosponsored by NASA.
- **SPECIAL PUBLICATION.** Scientific, technical, or historical information from NASA programs, projects, and missions, often concerned with subjects having substantial public interest.
- **TECHNICAL TRANSLATION.** English-language translations of foreign scientific and technical material pertinent to NASA's mission.

Specialized services that complement the STI Program Office's diverse offerings include creating custom thesauri, building customized data bases, organizing and publishing research results . . . even providing videos.

For more information about the NASA STI Program Office, see the following:

- Access the NASA STI Program Home Page at <http://www.sti.nasa.gov>
- E-mail your question via the Internet to [help@sti.nasa.gov](mailto:help@sti.nasa.gov)
- Fax your question to the NASA Access Help Desk at 301-621-0134
- Telephone the NASA Access Help Desk at 301-621-0390
- Write to:  
NASA Access Help Desk  
NASA Center for Aerospace Information  
7121 Standard Drive  
Hanover, MD 21076

NASA/TM—2002-211310

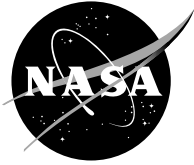

# ISS and STS Commercial Off-The-Shelf Router Testing

William D. Ivancic  
Glenn Research Center, Cleveland, Ohio

Terry L. Bell  
Lockheed Martin Global Telecommunications, Cleveland, Ohio

Dan Shell  
Cisco Systems, San Jose, California

National Aeronautics and  
Space Administration

Glenn Research Center

---

April 2002

## Acknowledgments

The authors would like to acknowledge Cisco Systems for providing the necessary equipment to perform this testing along with significant engineering and research support. We are also greatly appreciative of our colleagues at Goddard Space Flight Center working Internet protocol (IP) in space (<http://ipinspace.gsfc.nasa.gov/>) for providing advice and insight into some of the data link layer issues related to nonreturn-to-zero-inverted (NRZI) encoding and high-level data link control (HDLC). Thanks to Pat Carreon for being the Johnson Space Center/Electronic Systems Test Laboratory (JSC/ESTL) interface of the testing in ESTL (i.e., sponsor). Finally, many thanks to Rick Groh, Dave Stewart, Brian Kachmar, and Norm Melnyk for providing equipment, connectors, piece parts, cables, tools, and documentation from Glenn Research Center via next day mail.

Trade names or manufacturers' names are used in this report for identification only. This usage does not constitute an official endorsement, either expressed or implied, by the National Aeronautics and Space Administration.

Available from

NASA Center for Aerospace Information  
7121 Standard Drive  
Hanover, MD 21076

National Technical Information Service  
5285 Port Royal Road  
Springfield, VA 22100

Available electronically at <http://gltrs.grc.nasa.gov/GLTRS>

## Table of Contents

Summary .....	1
Introduction .....	1
Background.....	2
Goals .....	3
RF Link Quality .....	3
Communication Interfaces.....	3
Network Configurations .....	8
Test Tools and Configurations .....	14
Tests .....	14
PING .....	15
Phase Ambiguity .....	15
All 0's /1's.....	15
TCP Performance .....	16
UDP Performance .....	17
Demonstrations .....	19
Conclusions .....	20
Recommendations .....	21
Appendix .....	23
Test Equipment .....	23
Test Documentation .....	23
High-Level Data Link Control (HDLC) .....	23
UDP Testing Script .....	25
Router Configurations.....	25
UDP Streaming Test Results for December 12, 2000 .....	30
Test Personnel .....	33
References .....	34



# ISS and STS Commercial Off-The-Shelf Router Testing

William D. Ivancic  
National Aeronautics and Space Administration  
Glenn Research Center  
Cleveland, Ohio 44135  
Email: wivancic@grc.nasa.gov, Phone: 216-433-3494

Terry L. Bell  
Lockheed Martin Global Telecommunications  
Cleveland, Ohio 44135  
Email: Terry.L.Bell@grc.nasa.gov, Phone: 216-433-3725

Dan Shell  
Cisco Systems  
San Jose, California 95134-1706  
Email: dshell@cisco.com, Phone: 216-781-0507

## Summary

This report documents the results of testing performed using commercial off-the-shelf (COTS) routers and Internet protocols (IP's) to determine if COTS equipment and IP could be utilized to upgrade NASA's current Space Transportation System (STS), the Shuttle, and the International Space Station communication infrastructure. Testing was performed by NASA Glenn Research Center (GRC) personnel within the Electronic Systems Test Laboratory (ESTL) with cooperation from the Mission Operations Directorate (MOD) Qualification and Utilization of Electronic System Technology (QUEST) personnel. The ESTL testing occurred between November 1 and 9, 2000. Additional testing was performed at NASA Glenn Research Center in a laboratory environment with equipment configured to emulate the STS. This report documents those tests and includes detailed test procedures, equipment interface requirements, test configurations, and test results. The tests showed that a COTS router and standard transmission control protocols and Internet protocols (TCP/IP) could be used for both the Shuttle and the Space Station if near-error-free radio links are provided.

## Introduction

Testing was performed by NASA Glenn Research Center personnel within the Electronic Systems Test Laboratory (ESTL) with cooperation from the Mission Operations Directorate (MOD) Qualification and Utilization of Electronic System Technology (QUEST) personnel. The ESTL testing occurred between November 1 and 9, 2000. Additional testing was performed at NASA Glenn Research Center in a laboratory environment with equipment configured to emulate the Space Transportation System (STS).

Some of the more significant findings are

- Tests showed that a COTS router and standard TCP/IP protocols could be used for both the Shuttle and the Space Station even with delays of 1200 milliseconds so long as near-error-free radio links were provided. However, as the Tracking and Data Relay Satellite System (TDRSS) guaranteed channel quality of  $10^{-5}$  bit error rate (BER), performance was unacceptable.

- High-level data link control (HDLC) framing works well for data links such as those provided by the Shuttle and the International Space Station.
- Nonreturn to zero inverted (NRZI) encoding is mandatory for systems that do not correct for phase ambiguity or do not perform scrambling at the data link layer. NRZI will perform the necessary scrambling and correct for phase ambiguity.
- The current STS communication system requires all users to fix the radio link.

Based upon this testing, it is apparent that NASA would be able to deploy COTS networking and communication equipment and the TCP/IP protocol suite for both Shuttle and Space Station communications if the appropriate resources were brought to fix the data link layer and provide commercial standard interfaces to equipment. Deployment of COTS and IP would significantly reduce costs, eliminate many interface control documents, and reduce development and testing time.

## **Background**

The existing Shuttle and Space Station communications systems utilize nonstandard protocols and numerous unidirectional/simplex RF links. The Shuttle's system was designed using the 1960's and 1970's technology. The Space Station system was designed in the 1980's and borrowed heavily from the Shuttle design. By doing so, the Space Station remained backward, compatible with the Shuttle. The communications architectures of both systems are basically a combination of simplex circuits. The systems were not designed to incorporate multimedia packetized data on the same communication link. This is contrary to commercially based solutions in which various data types and various applications operate, for all practical purposes, on individual circuit-switched networks. There are plans to add high-speed applications such as high definition television (HDTV), voice over Internet protocol (VoIP), and video over Internet protocol (IPTV) to both the Shuttle and Space Station. These new applications are difficult to integrate into the legacy system and will certainly stress its capability to meet performance requirements. In addition, personnel trained to support these one-of-a-kind systems are nearing retirement or have retired. Also, the equipment itself is breaking and the components necessary for repair are no longer available.

By incorporating commercial modems and routers into the communication system, NASA would be able to use today's technology to perform all its communications needs including voice, video, command and control, monitoring, security, and transfer of research data between space and the end user. All of these functions can be performed better than with the current system at a reduced cost, increased reliability, and increased safety so long as the communication standards—both protocol and interface standards—are maintained end-to-end.

An excellent example of applications of COTS equipment to space-based network has been accomplished by the Russians. The Russian International Space Station (ISS) service module network consists of the following COTS products:

- Ethernet LAN running 100 Base-TX
- Cabletron SmartSwitch router
- Shielded cat-5 type cable
- 3Com 3C589D, or Intel Pro/100 PCMCIA Ethernet cards

The Russians are also using virtual private networks (VPN's) for security. Finally, all of the module's flight control systems as well as the operational and payload data systems are connected to the same LAN. The only change to the COTS products was to change the Cabletron router connectors from a commercial connector to ruggedized military connectors. One problem the Russian's are having with this system in integration to the NASA one-of-a-kind custom network.



## Goals

Three groups participated in the testing: Glenn Research Center/Cisco System, the Mission Control Center (MCC), and the ESTL. Each participated with a set of goals.

The ESTL test team's goal is to ensure full operation of any communication system over links that can degrade to  $10^{-5}$  BER. ESTL personnel are there to perform pass/fail testing in order to ensure full compliance.

The MCC personnel's goal was to see if a COTS router could replace the current Orbital Communication Adapter (OCA)<sup>1</sup> and what modifications, if any, are necessary.

Glenn Research Center and Cisco Systems personnel had three goals:

1. Determine if COTS equipment could interface to the STS system without expensive modifications
2. Demonstrate use of COTS data networking equipment and protocols with STS and/or ISS with a 1200 msec delay (600 msec in each link)
3. Demonstrate applications such as VoIP, IPTV, Telnet, and Wireless LAN's

## RF Link Quality

All TDRSS links are guaranteed to operate at only  $10^{-5}$ . That is the specification that the TDRSS contracts to for the Shuttle. Nominal operation however is near-error-free.<sup>2</sup>

The signal-to-noise ratio is not guaranteed nor is it provided. Thus, it is very difficult to determine what modulation and coding is necessary if one wished to bypass the Shuttle modems.

## Communication Interfaces

All testing was performed in the STS portions of the ESTL. Thus, the communication links and the associated hardware interfaces described are for the STS communications system both onboard (space) and at White Sands (ground).

It has been recognized that the predominant effort during test periods at ESTL is directed to get the interfaces working properly. That does not include time spent in preparation for the test. This time is almost exclusively due to the use of custom interfaces. Providing standard interface could eliminate better than the majority of the test and preparation time. This section provides a good illustration of the added work necessary to interface to custom systems.

Figure 1 shows the STS onboard communications system front end. The most appropriate point to incorporate COTS equipment would be at the IF interface using a commercial satellite modem. The interface would be at 647 MHz IF on the forward link and at 1875 MHz on the return link. This is certainly a viable solution technically. Particularly since the Doppler is removed via precompensation and postcompensation at White Sands. By using a COTS modem, all interfaces would be commercial standards and no special connectors or cabling would have to be developed out of the digital portion of the modem. However, this was not considered a viable solution due to the perception of increased risk and cost to change existing proven interfaces. In addition, the detailed electronic drawings indicate that portions of the modulated signal may be used to perform antenna tracking.

---

<sup>1</sup>The OCA is an IBM laptop running Microsoft Remote Access Service (RAS) software and custom interface cards that reside in the docking station. One of the functions the custom cards perform on the Shuttle is to bring the radio link quality up from  $10^{-5}$  to near-error-free.

<sup>2</sup>Near-error-free for this system is defined as a link quality of  $10^{-8}$  or better.

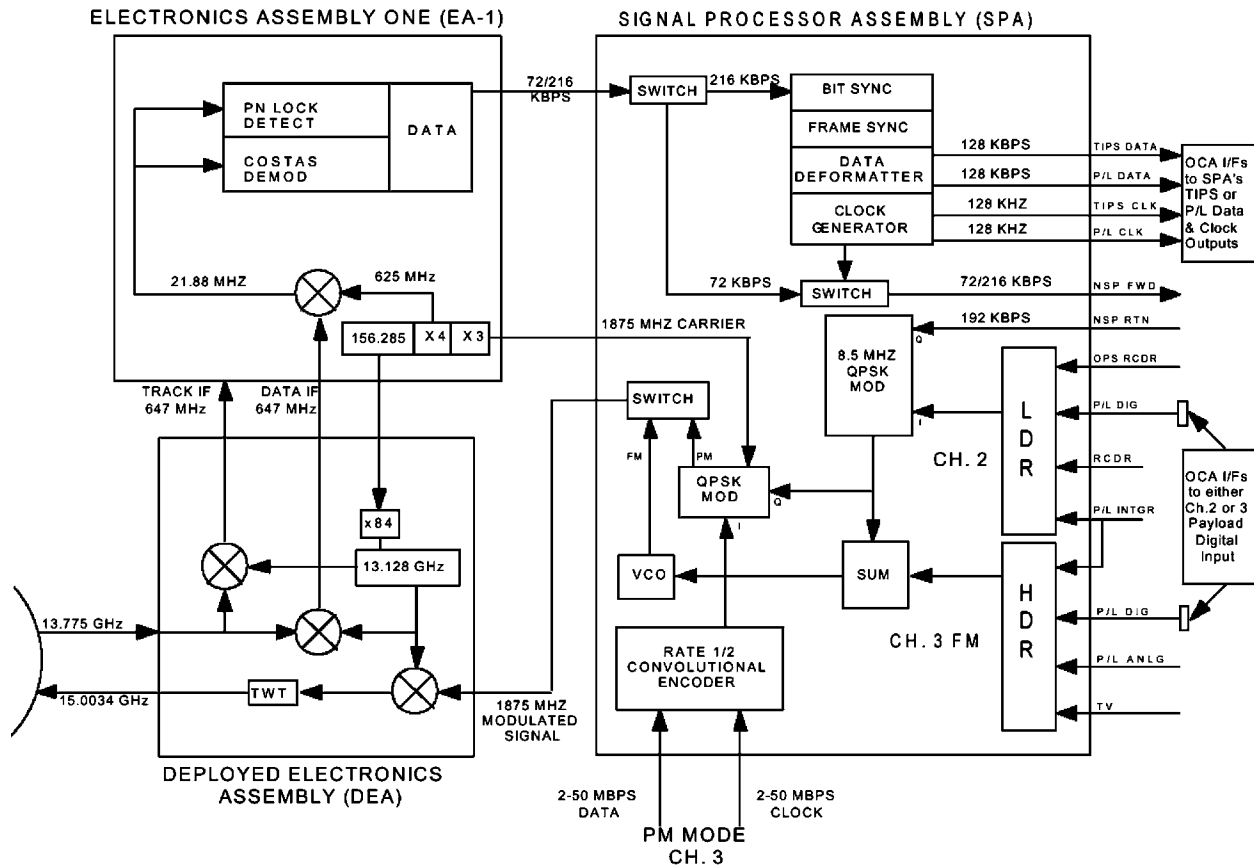

Figure 1.—STS onboard communications system front end.

The next most appropriate point to incorporate COTS equipment is at the digital interface after the modem. Unfortunately there are four different digital interfaces and the electrical and physical characteristic vary for each of the four interfaces both on the ground and onboard STS. One interface is associated with the 128 kbps forward link. Three interfaces are associated with the return link: the channel 2 FM, channel 3 FM and channel 3 PM interfaces. All four links are guaranteed to operate at only  $10^{-5}$  (even the forward error correction (FEC) encoded link). Channel 2 FM and channel 3 FM are straight binary phase shift keying (BPSK), with no coding, no phase ambiguity resolution, and no scrambling. Channel 3 PM is implemented as 5 parallel 10 Mbps convolutional encoders/decoders with an over guaranteed BER of  $10^{-5}$  after FEC.

Figure 2 shows the STS forward link. The space portion would reside onboard the STS. The ground portion would reside at White Sands. The numbers on the interfaces corresponds to the ESTL interface specification.

Onboard the Shuttle, the signal processing assembly (SPA) provides a 128 kbps data stream and 128 kbps clock and interfaces 1 and 2, respectively. Both signals are differential balanced 75 ohm lines with the high state at 2.5 V (+1.0 V, -0.5 V) signal line to signal ground and 0.0 V (+0.5 V, -0.0 V) signal return line to signal ground.

On the ground, the data is provided by the router (interface 3), but the clock is provided by the Shuttle forward link equipment (interface 4). Thus, the router acts as DTE (data terminal equipment) while the Shuttle forward link equipment performs as DCE (data communication equipment). The Shuttle interfaces want to see differential balanced lines at 78 ohms with RS422 signal levels. However, the commercial

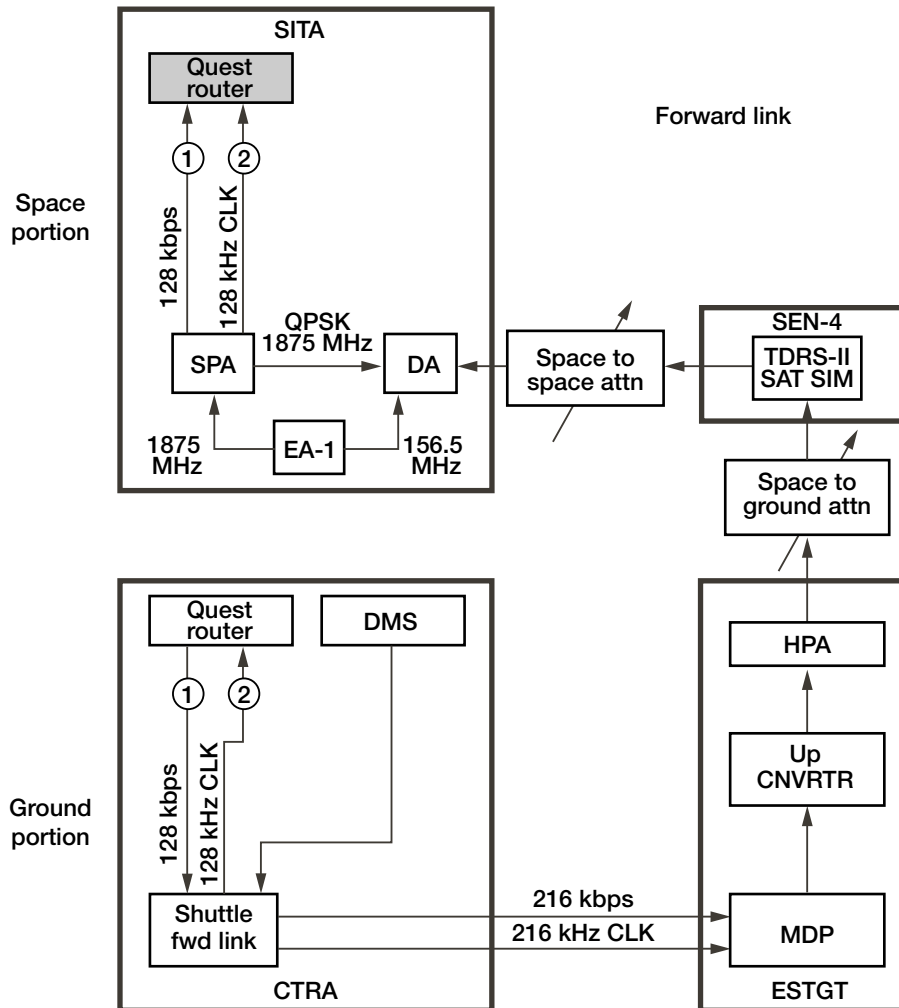

Figure 2.—Forward link.

RS422 specification is for 100 ohms. All connectors are nonstandard connectors and pinouts. Thus, one cannot simply connect the RS422, 37-pin connector to the ground or Shuttle interface. Rather, special cabling and pinouts are required and have to be generated by each user of the system.

Figure 3 shows the return link interfaces onboard the Shuttle and on the ground.

Interfaces 5 and 6 are capable of 8-48 Mbps data and clock, respectively. This is the channel 3 PM interface. The signals into the SPA onboard the Shuttle are single ended into 50 ohms. The data signal, high signal (logic level 1) is +4.5 to +6.5 V while the low level is -0.5 to +0.5 V. Notice that the clock level is different than the data level. The clock level is +3.7 to +6.5 V for logic level 1 and -0.5 to +1.5 V for logic level 0.

Interfaces 7 and 8 are differential balanced lines with logic high at 1.8 to 5.0 V peak-to-peak. Interface 7 is the channel 2 FM interface and is capable of up to 2 Mbps. Interface 8 is the channel 3 FM and is capable of up to 4 Mbps. The clocks for channel 2 FM and channel 3 FM are generated from the data and take place inside the SPA.

Interfaces 9 and 10 are the channel 2 FM data and clock, respectively. Signal levels are compatible with RS422A.

Interfaces 11 and 12 are the channel 3 FM data and clock. Signal levels are 50 ohm transistor transistor logic (TTL) which is quite different than the levels onboard the Shuttle.

Interface 13 and 14 are the channel 3 PM data and clock. Signal levels are differentially balanced emitter coupled logic (ECL). In addition, the balanced signals come from two separate cables that provide the plus (+) and minus (-) signals.

Almost every interface signal level is different for different channel modes and between the ground and the space interfaces (table I). Because of this, special circuitry and cables must be developed either on the ground or in space or both in order to utilize COTS equipment.

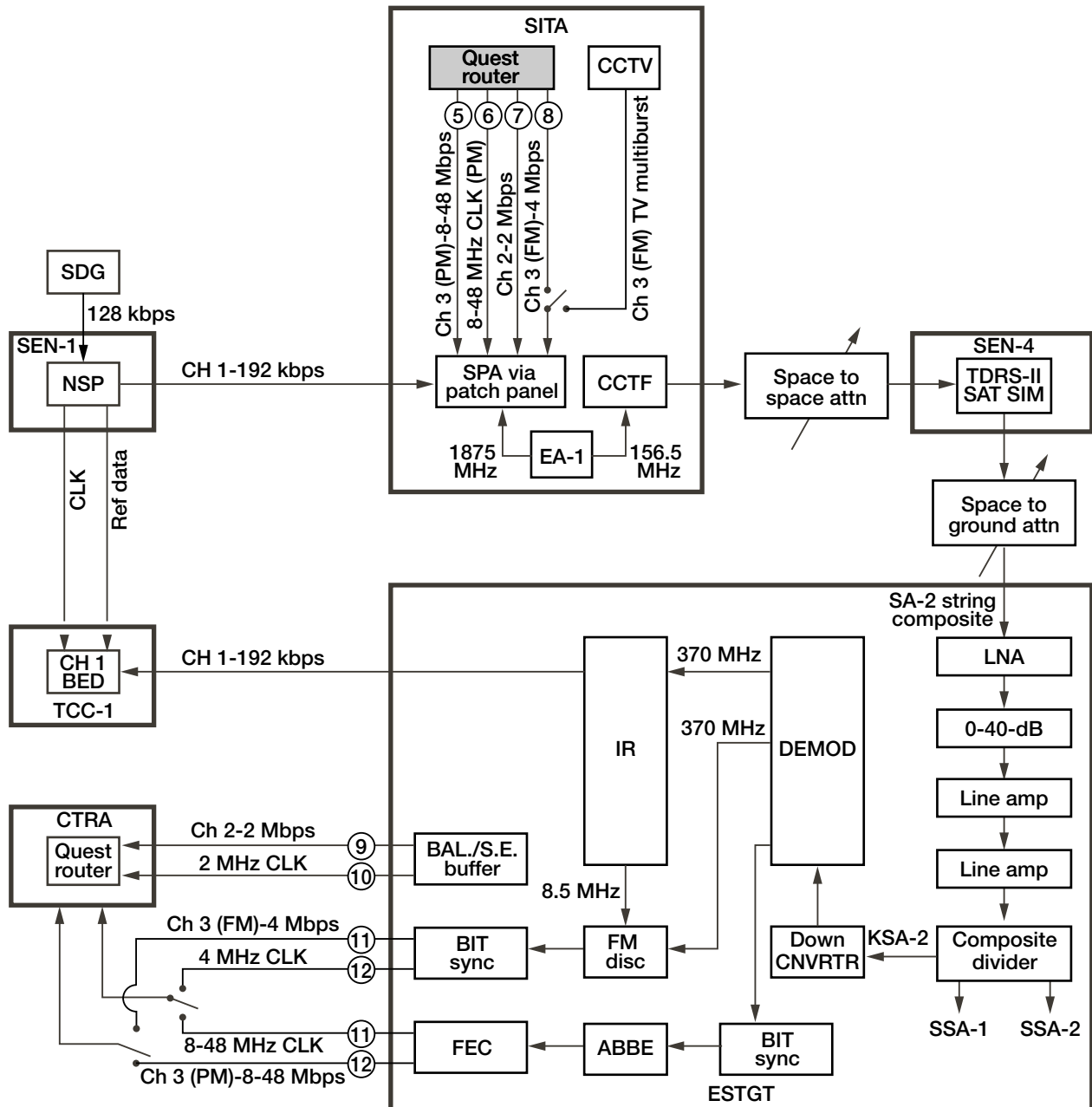

Figure 3.—Return link.

TABLE I.—ESTL/QUEST TEST INTERFACE MATRIX

Int No.	Signal	SOURCE					DESTINATION				
		Source	Level/ Imped.	Signal Desc.	Connector	Cable/ Imped.	Dest.	Level/ Imped.	Signal Desc.	Connector	Interface
1	128 Kbps Fwd data	SPA	See <b>note 1</b> / 75 Ω	Diff. Balanced	Trompeter Patch plug PL75-9	TSP/ 75 Ω (TWC 78-2)	Quest Router	RS422 78 Ω	Diff. Balanced	Trompeter Twinax (See <b>note 4</b> )	
2	128 KHz clock	SPA	See <b>note 1</b> / 75 Ω	Diff. Balanced	Trompeter Patch plug PL75-9	TSP/ 75 Ω (TWC 78-2)	Quest Router	RS422 78 Ω	Diff. Balanced	Trompeter Twinax (See <b>note 4</b> )	
3	128 Kbps Fwd data	Quest Router	RS422a/ 100 Ω	Diff. Balanced	DB37 P	Trompeter Twinax (See <b>note 4</b> )	Shuttle Fwd Link	RS422 78 Ω	Balanced	Trompeter Patch jack J152	Quest Supplied Adapter
4	128 KHz clock	Shuttle Fwd Link	RS422/ 78 Ω	Balanced	Trompeter Patch jack J72-F	TSP/ 75 Ω (TWC 78-2)	Quest Router	RS422 78 Ω	Diff. Balanced	Trompeter Twinax (See <b>note 4</b> )	
5	8-48 Mbps Rtn data	Quest Router	RS422a Or HSSI See <b>note 5</b>	Diff. Balanced	DB37 S	Coax/ 50 Ω	SPA	See <b>note 2</b> / 50 Ω	Single-ended	BNC PL20-3	Quest Supplied Adapter
6	8-48 MHz clock	Quest Router	RS422a Or HSSI See <b>note 5</b>	Diff. Balanced	HD50 S	Coax/ 50 Ω	SPA	See <b>note 2</b> / 50 Ω	Single-ended	BNC PL20-3	Quest Supplied Adapter
7	2 Mbps Rtn data	Quest Router	RS422a/ 100 Ω	Diff. Balanced	DB37 S	Trompeter Twinax (See <b>note 4</b> )	SPA	1.8- 5.0V/ 75 Ω	Diff. Balanced	Trompeter Patch plug PL75-9	Quest Supplied Adapter
8	4 Mbps Rtn data	Quest Router	RS422a/ 100 Ω	Diff. Balanced	DB37 S	Trompeter Twinax (See <b>note 4</b> )	SPA	1.8- 5.0V/ 75 Ω	Diff. Balanced	Trompeter Patch plug PL75-9	Quest Supplied Adapter
9	2 Mbps Rtn data	ESTGT IR	RS422a/ 100 Ω	Diff. Balanced	Trompeter Patch jack J72-F	Twinax/ 100 Ω	Quest Router	RS422 78 Ω	Diff. Balanced	Trompeter Twinax (See <b>note 4</b> )	Bal/S.E. buffer
10	2 MHz clock	ESTGT IR	RS422a/ 100 Ω	Diff. Balanced	Trompeter Patch jack J72-F	Twinax/ 100 Ω	Quest Router	RS422 78 Ω	Diff. Balanced	Trompeter Twinax (See <b>note 4</b> )	Bal/S.E. buffer
11	4 Mbps Rtn data	ESTL Bit sync	TTL/ 50 Ω	Single-Ended	Trompeter Patch jack J3-F	Coax/ 50 Ω	Quest Router	RS422 78 Ω	Diff. Balanced	Trompeter Twinax (See <b>note 6</b> )	
12	4 MHz clock	ESTL bit sync	TTL/ 50 Ω	Single-Ended	Trompeter Patch jack J3-F	Coax/ 50 Ω	Quest Router	RS422 78 Ω	Diff. Balanced	Trompeter Twinax (See <b>note 6</b> )	
13	8-48 MHz clock	FEC	ECL/ 50 Ω (-2V)	Diff. Balanced (See <b>note 3</b> )	Trompeter Patch jack J72-F	Coax/ 50 Ω	Quest Router	HSSI (See <b>note 5</b> )	Diff. Balanced	Coax/ 50 Ω	
14	8-48 Mbps Rtn data	FEC	ECL/ 50 Ω (-2V)	Diff. Balanced (See <b>note 3</b> )	Trompeter Patch jack J72-F	Coax/ 50 Ω	Quest Router	HSSI (See <b>note 5</b> )	Diff. Balanced	Coax/ 50 Ω	

**Note 1:** 0.0v (+0.5v, -0.0v) signal rtn line to signal gnd, Low State: 0.0v (+0.5v, -0.0v) signal line to signal ground, High State: 2.5v (+1.0v, -0.5v) signal rtn line to signal gnd

**Note 2:** Data Logic 1: +4.5v to +6.5v Data Logic 0: -0.5v to +0.5v, Clock Logic 1: +3.7v to +6.5v Clock Logic 0: -0.5v to +1.5v

**Note 3:** Balanced signal comes from two separate cables that provide the (+) and (-) signals

**Note 4:** Trompeter twinax cable PCB0W30PCB-120. Quest will provide AD78 barrel adapter, if needed.

**Note 5:** For rates greater than 8 Mbps, HSSI will be used. HSSI cable cut and diff line brought out to BNC pin connectors. BNC shield to signal ground. Requires translator circuit, TTL 50 Ω to diff ECL. For rates less than 8 Mbps, the RS422 serial interface can be used. Trompeter twinax cable PCB0W30PCB-120. Quest will supply the AD78 barrel adapter, if needed. Requires translator circuit, TTL 50 Ω to diff TTL RS422 standard.

**Note 6:** Trompeter twinax cable PCB0W30PCB-120. Quest will provide AD78 barrel adapter, if needed. Requires translator circuit, TTL 50 Ω to diff TTL RS422 standard.

## Network Configurations

This section documents the test configurations and connectors for a system with and without the satellite channel emulator hardware used to provide delay. The purpose of this section is to document the connector and system configurations. The complexity of the various configurations necessary to test custom systems due to the nonstandard connectors and clock and data generation are illustrated.

Figure 4 shows the network layout when no delay units are used. This is the configuration that would be used in the actual network. The ground and space networks are mirror images. Each router has four serial ports available with two active. Each router had one 100BaseT fast Ethernet network interface card (NIC) and a VoIP module. The VoIP modules used could handle two phones. Other VoIP modules could actually tie into a private branch exchange (PBX). The fast Ethernet interface is connected to a 24-port IP switch, which is used to connect additional hosts as well as a wireless access point to enable wireless communications to the local area network (LAN) via the IEEE802.11 wireless Ethernet specification.

It is possible to implement this configuration with only one serial port on the ground router and one serial port on the space router when RS422 clock rates and signal levels are used by both forward and return links (fig. 16). We utilized two units in order to simplify the clock and connector configurations. In addition, by deploying two units, the architecture is pictorially more representative of an actual system. Also, for a system using a return link with high-speed serial interface (HSSI) rates (up to 50 Mbps) a second serial interface is required.

Figure 5 shows the connector layout for the space-to-ground link when no delay units are in the system. The 37 socket-to-twinax connectors are custom made.

The transmitting serial port on the ground router is setup as a DTE and receives clock from the White Sands<sup>3</sup> equipment on the RS422 station-timing lines (connector 4). When at White Sands, only data is input into the transmit portion of the ground terminal via the station-timing lines (connector 3). The clock is then derived from the data. However, when running back-to-back testing to verify connectors and routing, the clock is required by the space router. This clock is provided by the transmit-timing lines of the RS422 interface. In addition, when running back-to-back, a clock source is needed into the station-timing lines. We provided this by employing an unused serial port on the 4-port NIC to provide just a clock.

The receiving serial port on the space router is configured as a DTE. Clock and data are provided by the STS receiving equipment and are input to connectors 1 and 2 via the receive-data and receive-timing on the RS422 serial interface.

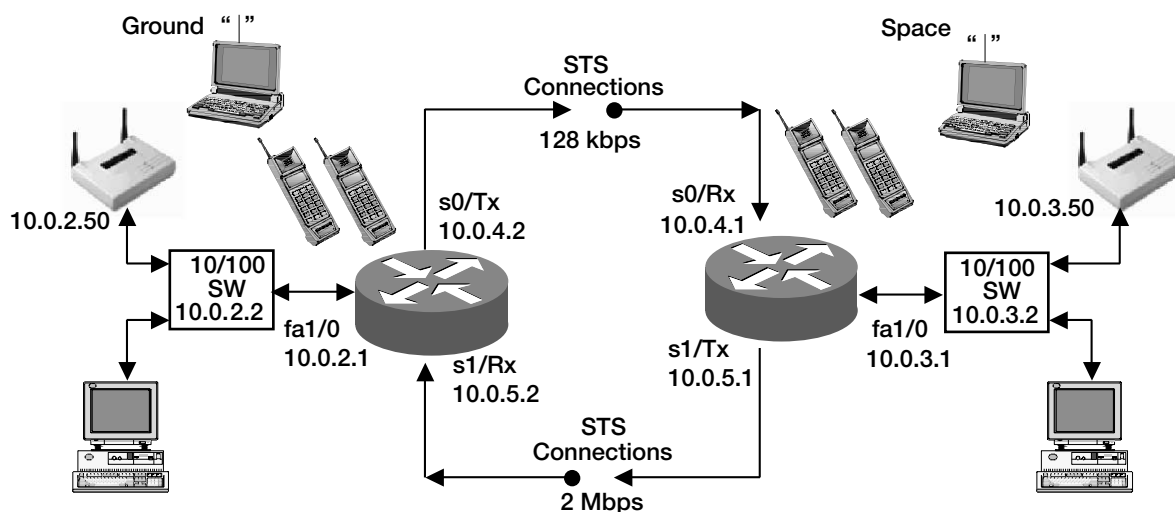

Figure 4.—Network topology without delay units.

<sup>3</sup>For this document, White Sands refers to the White Sands ground portion of the ESTL STS test facility and interfaces. The interfaces in the ESTL are the same as those at the actual White Sands facility. STS refers to the space portion of the network.

Figure 6 shows the connectors for the space-to-ground link when no delay unit is present. The twinax-to-37-pin and twinax-to-37-socket connectors are custom made.

The transmitting serial port on the space router is configured as a DCE and provides clock and data. The Cisco routers can generate clocks at discrete rates. One of those rates is very close to 128 kbps. This is the setting used in the tests. The STS space-to-ground generates its own clock from the data provided. However, when running back-to-back tests with the groundside router, a clock is required. Thus the clock out of the STS router can provide a clock via the return-timing lines.

The receiving serial port on the White Sands router is configured as a DTE. Clock and data are provided by the White Sands receiving equipment and are input to connectors 9 and 10 or 11 and 12 via the receive-data and receive-timing lines on the RS422 serial interface.

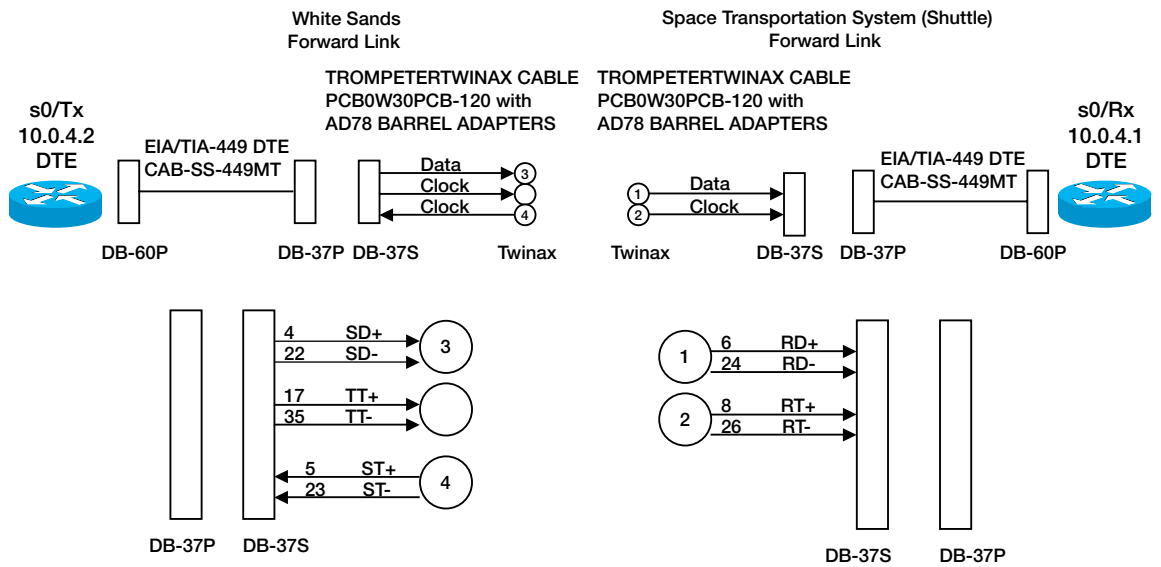

Figure 5.—Connectors for ground-to-space with no delay.

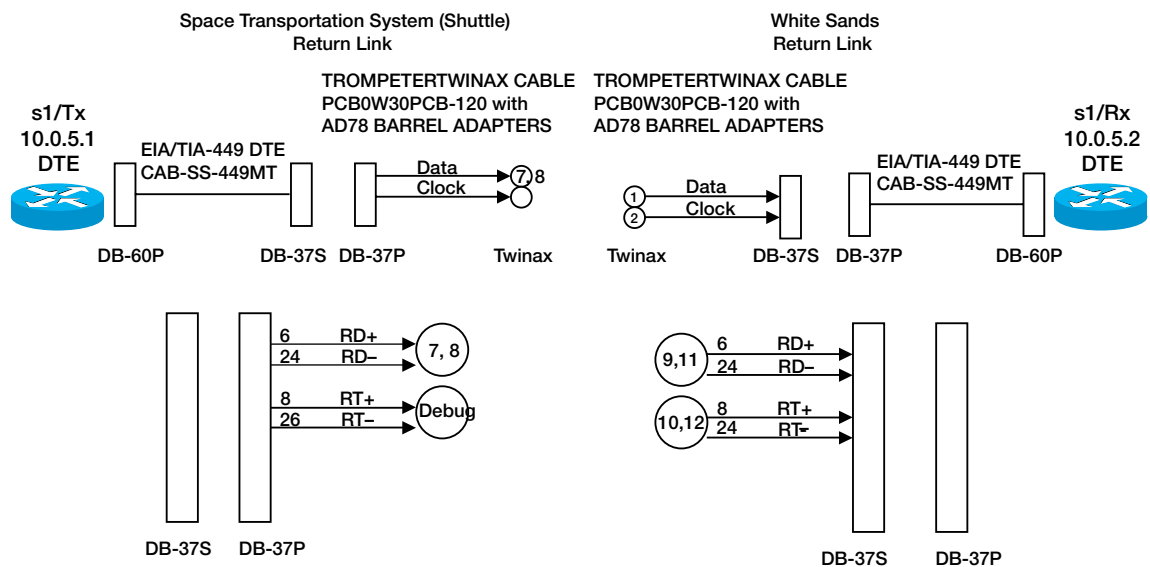

Figure 6.—Connectors for space-to-ground with no delay.

Figure 7 shows the network topology when delay units are inserted into the system. The delay units are Adtech SX/14 satellite channel emulators. As in the no-delay topology, it is possible to implement this configuration with only one serial port on the ground router and one serial port on the space router and one delay unit when RS422 clock rates and signal levels are used by both forward and return links. Again, we utilized two units in order to simplify the clock and connector configurations.

Figure 8 shows the location of the connectors when a delay unit is present and the configuration of the serial ports on the routers. The White Sands transmitting and receiving serial ports are configured as DTE's. The STS receiving port is configured as a DTE while the transmitting serial port onboard STS is configured as a DCE. All DTE ports receive clock whereas the DCE port provides clock.

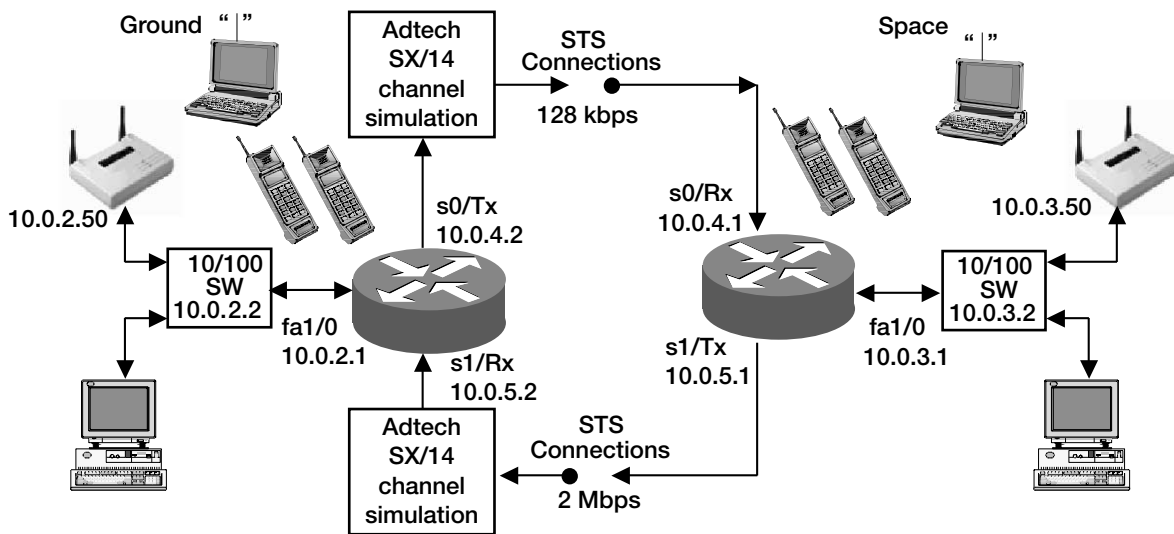

Figure 7.—Network topology with delay units.

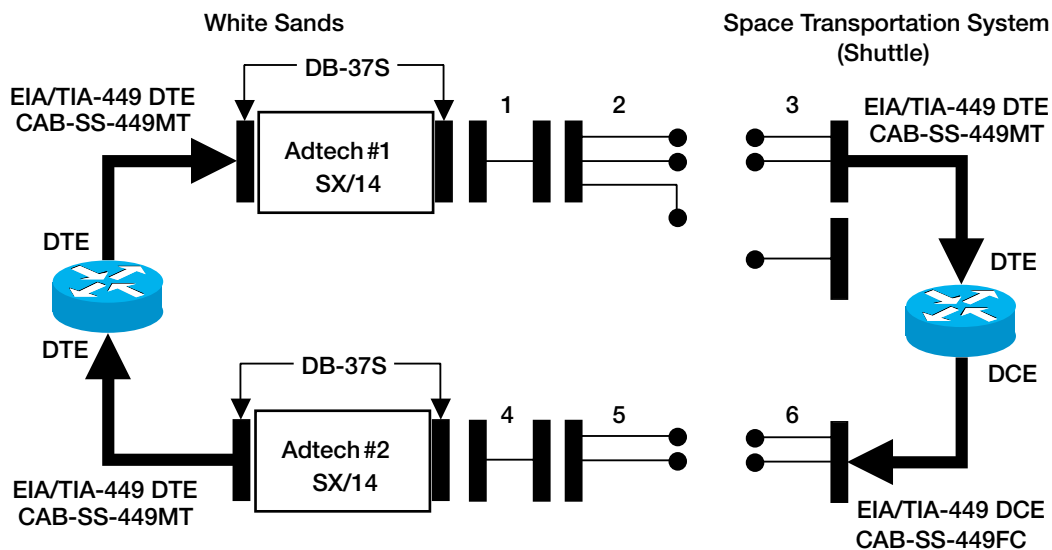

Figure 8.—Connector location with delay units present.



Figure 9 illustrates the configuration of the Adtech SX/14 channel emulators. The ground-to-space delay unit is configured as DTE/to DTE. The channel timing is from the internal synthesizer via the terminal timing input of the “west” connector for back-to-back testing and via the external input when interfaced to the ESTL test facility. The space-to-ground delay unit is configured as DTE/to DCE with channel timing from the internal synthesizer referenced to the DCE receive-timing clock.

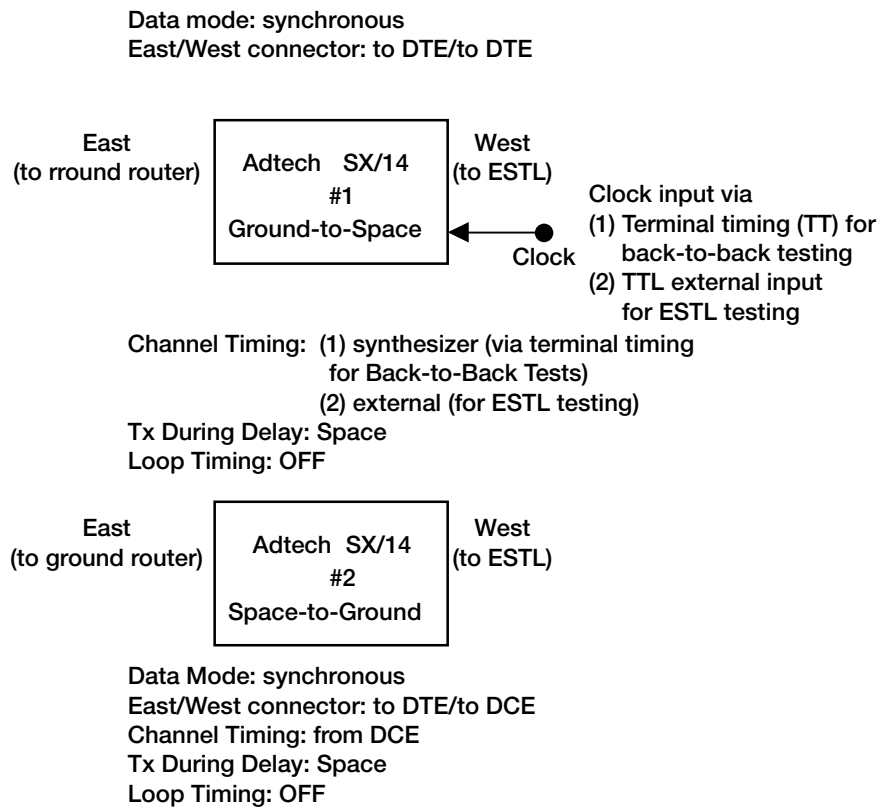

Figure 9.—Adtech SX/14 configurations.

Figure 10 shows the special connectors required for the forward and return links when the Adtech SX/14 channel emulator units are deployed. Note, “S” is socket and “P” is pin. Also note that there is a special connector labeled connector 7. This connector goes to one of the spare serial interfaces on the ground router. That interface is configured as a DCE and provides clock when running back-to-back testing.

Figure 11 illustrates the configuration utilized for back-to-back testing with the delay units present. The clock off serial port 3 of the transmitting serial interface is used to provide clock thereby emulating the White Sands ground terminal uplink equipment. Note, the delay units could also be used for generating errors into either portion of the link. This was the setup used to validate the routing setup within the space and ground based router configurations. This was also the configuration used at Glenn Research Center to troubleshoot the high packet loss seen for UDP testing at BER's of  $10^{-6}$  while at ESTL and to complete testing of multicast protocols using IP/TV (see Testing section for details).

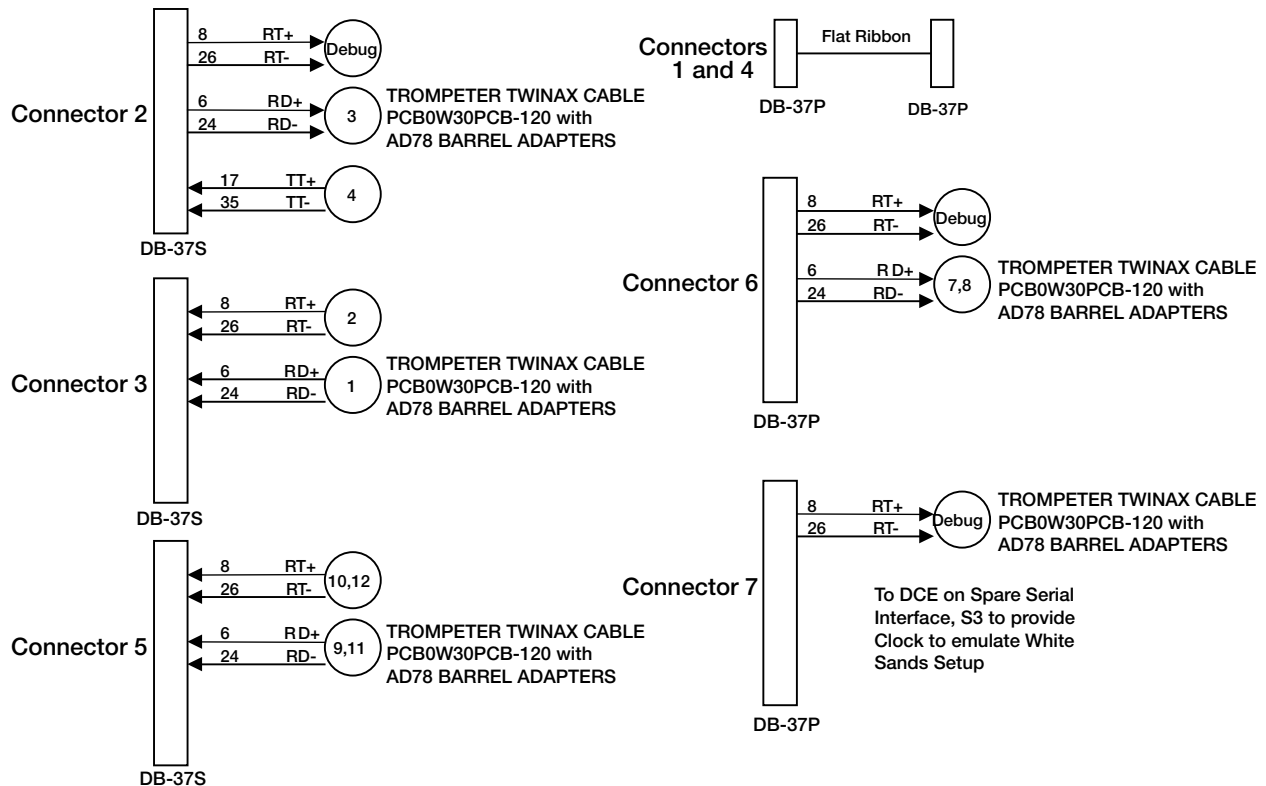

Figure 10.—Forward and return link connectors with delay unit present.



## Test Tools and Configurations

TCP transfers were run using the TCP extensions for selective acknowledgment (SACK) (ref. 1), time-stamps, and large windows (ref. 2). The linux TCP implementation was used at both the sender and receiver. The payload packet size was 1440 bytes as this is typical of Ethernet packets and is small enough to ensure no fragmentation when all TCP extensions are utilized.

We use the network performance application `ttcp` to perform the majority of our tests. The `ttcp` application we used was modified to enable setting of the priority bits for quality of service (QoS) testing. Some example `ttcp` commands are shown below. The “-s” transfers a fixed repeated sequence between hosts as a memory to memory transfer. The “-u” is used for UDP transfer. The “-b” sets the buffer size—this is useful for TCP testing to set the send and receiver buffers thereby tuning the system. A 300,000-byte buffer will result in a 2-Mbps maximum data transfer for a 1.2-second round-trip time. The “-n” sets the number of packets sent. The “-p” sets the priority bit. The “*host*” is the receiving hosts IP address. Finally, the “<filename>” redirects a file to be transferred rather than a memory-to-memory transfer. The “-n” is meaningless when redirection is used.

```
ttcp -s -t -l1440 -b300000 -n5000 -p6 host
ttcp -u -t -l1440 -b300000 -n5000 -p6 host < filename
ttcp -t -l1440 -b300000 -n5000 -p6 host < filename
```

The majority of the tests were performed using the 2-Mbps space-to-ground link for data transfer and the 128-kbps ground-to-space link for acknowledgments.

## Tests

Four tests were performed that provided measurable engineering data. These are described under this test section. These tests include Packet InterNet Gopher (PING) tests, all 0's/1's, TCP performance testing, and UDP performance testing. Unless otherwise stated, the testing was performed using the channel 2 FM, 2-Mbps return-link for file transfer and the 128-kbps forward-link for acknowledgments. Figure 13 shows the detailed network configuration including the addressing.

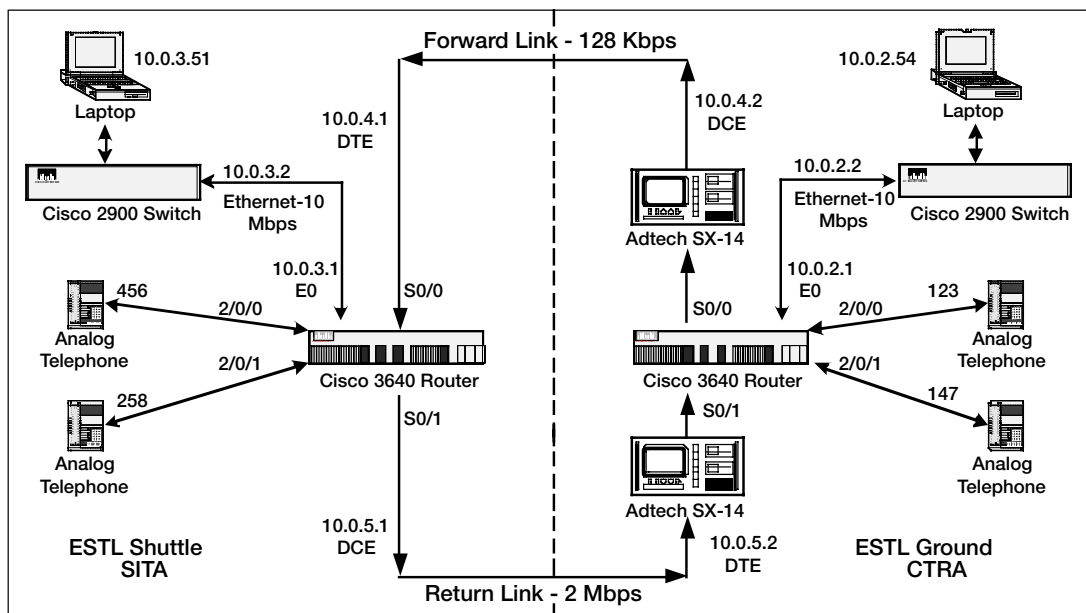

Figure 13.—Test network configuration.

## PING

Packet InterNet Gopher (PING) is part of the standard TCP/IP suite of protocols. PING is extremely useful for debugging network problems. It allows one to check their connectivity with other devices, or to check whether your own TCP/IP stack is working properly. A PING is an echo test that uses the Internet control message protocol (ICMP) to determine if a host is active. A message is sent from one host to another and a reply returned. PING's are used to verify a particular host is up and running as well as to verify routes exist between hosts. PING's also provide the round-trip time measurements.

We used PING's to verify network configurations and setup—particularly to verify correct settings in the delay units. PING's were used prior to all TCP and UDP tests as well as prior to all application demonstrations to ensure correct network configuration.

## Phase Ambiguity

Neither channel 2 FM nor channel 3 FM perform phase ambiguity. COTS router interfaces are not designed to perform phase ambiguity as this is considered a radio modem function. Thus during our initial tests to validate router configuration, the serial interface on the routers were initially configured for HDLC framing and the default channel encoding, NRZL (nonreturn-to-zero level). The polarity of the differential data lines had to be manually inverted relative to the clock lines approximately 50 percent of the time in order to correct the phase ambiguity. This was later corrected by configuring the serial interfaces for nonreturn-to-zero inverted (NRZI)—see All 0's/1's for a detailed explanation.

## All 0's/1's

Neither the channel 2 FM nor channel 3 FM links perform scrambling. Because of this, the data goodput<sup>4</sup> will degrade severely when large strings of 1's or 0's are sent over the RF link.

The serial interfaces on the routers were initially configured for HDLC framing and NRZL encoding. The tests were performed on the space-to-ground 2-Mbps link operating at nominal (near-error-free) performance. File transfers for files containing all 1's or all 0's were run using `ttcp`. The following commands were entered from hosts 10.0.3.51 and 10.0.2.54, respectively:

```
ttcp -t -l1440 -b30000 -n5000 -p6 10.0.2.54 < allones  
ttcp -r -l1440 -b30000 -n5000 -p6
```

For the channel 2 FM unscrambles link, the NRZL encoding resulted in an unusable communication link with approximately 50 percent errors.

The serial interfaces on the routers were then configured for HDLC framing and NRZI encoding. The result was 0 BER. In addition, NRZI encoding corrected for phase ambiguity resolution problem.

NRZI is a differential encoding technique. Differential encoding inherently corrects for phase ambiguity. This comes with some cost, as single bit errors on the transmission path will result in two successive errors in the decoded bit-stream.

---

<sup>4</sup>Goodput refers to the measurement of actual data successfully transmitted from the sender(s) to receiver(s). Goodput is the useful data throughput. It excludes overhead, retransmission, and other unacceptable or redundant data at the receiving host.

## TCP Performance

TCP is the underlying reliable transport protocol for the majority of the Internet services. It is used by application protocols such as FTP (file transfer protocol) (telnet, secure shell, and Web browsing to name a few). TCP was originally designed to be reliable and robust to accommodate military requirements such as satellite communications and nuclear war. As the use of TCP grew, improvements were added to the protocol. One of the critical improvements was to add congestion control algorithms to TCP so that the TCP would perform well on a shared network. Current implementations of TCP assume that a packet loss is the result of congestion. TCP initially increases its transmission rate exponentially. This is called slow start. Once a packet is perceived to have been lost, TCP halves its transmission rate and then continues to grow its transmission rate linearly by approximately one packet every round-trip time. The rate halving and linear rate increase is why TCP will perform very poorly for single flows (only one user on the network) on long-delay, error-prone links.

TCP performance tests were run for nominal links and for links with  $10^{-6}$  BER. The `ttcp` application was used for these tests for both memory-to-memory transfers and file transfers. The buffer size was set to 300,000 bytes at the receiver in order to optimally tune TCP for maximum throughput without going into self-congestion. The packet payload length was set to 1440 bytes to ensure no packet fragmentation due to application of TCP extensions. Large windows, selective acknowledgments and time-stamp options were enabled. A large file of approximately 12 Mbytes of random data was selected for the final tests. The data link used HDLC framing with NRZI encoding. The following commands were entered from hosts 10.0.3.51 and 10.0.2.54, respectively:

```
ttcp -t -l1440 -b300000 -n5000 -p6 10.0.2.54 < vel2posd0  
ttcp -r -l1440 -b300000 -n5000 -p6
```

Figures 14 and 15 show TCP transfers under error-free and  $10^{-6}$  BER conditions over a 1.2 second delay. The maximum throughput for TCP was close to the link speed of 2 Mbps under error-free conditions. However, once errors were introduced, the performance degraded quickly due to the linear rate increase and the long round-trip times. This is evident in figure 15 by the number of retransmissions and the inability of TCP to fill the link. Here, average TCP throughput was approximately 70 kbps for BER of  $10^{-6}$ . Packet loss was approximately 2 percent for a BER of  $10^{-6}$  as read off the router interface counters.

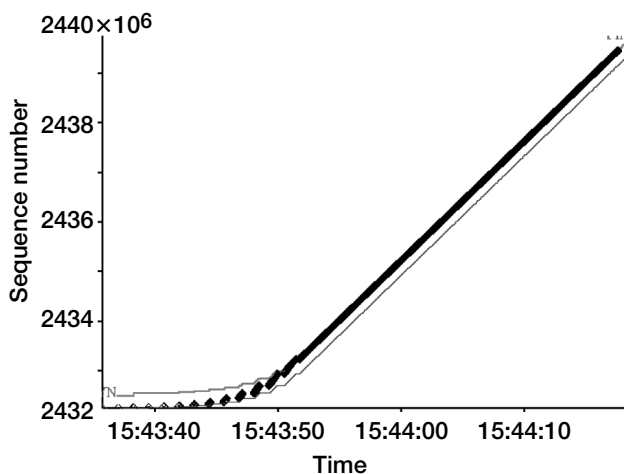

Figure 14.—Tuned TCP/BER = 0.

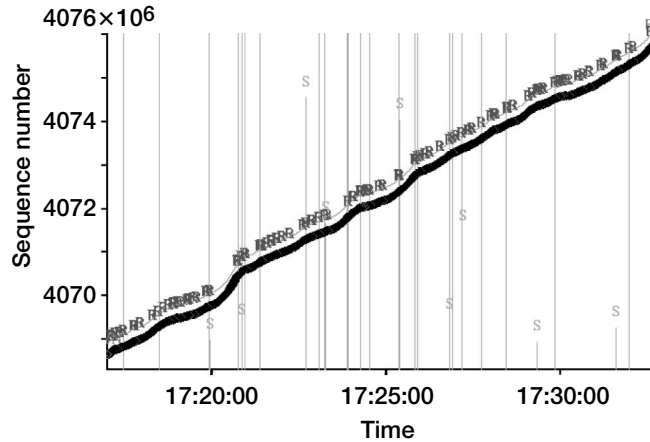

Figure 15.—Tuned TCP/BER =  $1.0^{-6}$ .

The results show that TCP will guarantee delivery of all data, even over a highly errored link with long delays. However, when attempting to transfer large files over error-prone, long-delay links, TCP is not recommended. A rate-based user datagram protocol (UDP) file delivery application may be more appropriate particularly if the link is not shared.

### UDP Performance

The UDP tests were performed in order to get packet throughput numbers for the return and forward links. These tests became the most difficult to perform and resulted in conflicting and initially unexplained performance numbers while testing in ESTL at Johnson Space Center (JSC). The UDP tests were recreated at GRC. The GRC test results should be used for packet throughput. However, the ESTL test did reveal some necessary router configurations necessary to ensure proper operation. The following section contains the detailed test setup at ESTL and GRC as well as the test results.

Figure 13 is representative of the test setup. The fast Ethernet ports on the 3640 routers auto-negotiated with the 2900 Catalyst switches to 100BaseT (100 Mbps). The laptops' Ethernet NIC's also auto-negotiated with the 2900 switches to 100BaseT. The data rate out of the space router's serial port was set to 2,015,232 bps—this was the closest discrete frequency to 2 Mbps that the router could provide. The data link layer protocol was HDLC with NRZI encoding. (It is very important to understand HDLC framing to understand the test results of this section. An explanation of HDLC operation is provided in the appendix.)

The initial return-link throughput measurements were obtained by clearing the counters and then running UPD `ttcp` tests using the following command on host 10.0.3.51:

```
ttcp -u -s -t -l1440 -b30000 -n5000000000 -p6 10.0.2.54
```

This test method turned out to generate misleading results. Since host 10.0.3.51 was operating on a 100 Mbps link and the serial return link was set for approximately 2 Mbps, the router had to drop approximately 98 percent of the packets at the output buffer of the serial card. We did not consider this to be a problem as we were only concerned with counting packets transmitted out of the interface, not dropped at the output buffer. We were mistaken however as apparently the interface could not handle the packet

dropping, HDLC framing, and NRZI encoding as the test results will indicate. This test configuration does not represent real networks as one would never put 100 Mbps of data into a 2-Mbps link. In hindsight, a better test would have been to use a rate-limited transfer application such as DBS (ref. 3) rather than `ttcp`.

The measurement technique used to determine packet throughput was to read out the number of packets transmitted from the space serial port. Once we had sufficient packets transferred, the `ttcp` application was terminated and the packets transited out of the space serial port and the packet received by the ground serial port were recorded along with other meaningful information such as Communications Research Center (CRC) errors and aborts. Assuming no losses, the packet counts should match to within perhaps three or four packets (due to the inability to precisely clear the counters between transmitter and receiver). In addition, `ttcp` was run at the receiving host to get instantaneous throughput measurements and `tcpdump` was run at the receiving host to view any unusual behavior.

Initial test results indicated no packet loss and 2-Mbps throughput at nominal performance and 70 percent packet loss at  $10^{-6}$  BER with the majority of the packets received being rejected due to CRC errors or aborts. This result did not match theory and was most unexpected. In addition, the result did not match the packet loss of approximately 2 percent for TCP operation over a  $10^{-6}$  BER link. Observations of the `tcpdump` real-time data at the receiving hosts showed a starting and stopping of the data flow. This type of bursty behavior is indicative of loss-of-frame synchronization.

Since `-s` option for `ttcp` results in the same payload pattern being transmitted, the GRC team hypothesized the payload errors were resulting in false HDLC frame headers, which would then cause the entire payload to shift and be out of synchronization. However, this should not happen with HDLC as the payload bytes should never match the HDLC flag bytes (see HDLC in appendix).

In order to remove the possibility that the repetitive payload pattern was causing problems, a script was written to continuously transmit any specified file using the UDP capabilities of `ttcp`.

The ESTL test team provided a small file consisting of eight copies of a 127-bit pseudorandom pattern. Results using this small file we saw a packet loss of approximately 2 percent at  $10^{-6}$  BER, which matched our TCP results. However, this packet size was very small and most of the time the link was idle waiting for the transmitting system to loop and reload the file. Thus, we did not have any packet drops at the output buffer of the return-link serial port.

The GRC team ran the same tests at ESTL using the 12 Mbyte file. The results were again 70 percent packet loss at  $10^{-6}$  BER. The GRC team was able to duplicate the 70 percent packet loss with either the ESTL equipment degrading the link or by setting the ESTL equipment for nominal operation and having the Adtech SX/14 provide  $1.0 \times 10^{-6}$  BER.

On December 12, 2000, GRC personnel duplicated the JSC ESTL setup and repeated the UDP streaming tests in GRC's laboratory using the Adtech SX/14 channel emulators to create delay and errors. Setup included using a 100-Mbps source into a fast-Ethernet NIC and outputting via a serial NIC (serial 0/1) at 2 Mbps. GRC personnel noted that if the serial output interface was not overload, a packet loss of approximately 1 to 2 percent resulted at  $10^{-6}$  BER. GRC personnel tested this using a script that basically looped many times through a `ttcp` call where `ttcp` sent a small number of packets. The tests indicate that the Cisco router NT-4 interface cannot perform both the HDLC framing with bit stuffing and packet dropping at the output of the output queue when excessive data is being forced through that link.

By applied committed access rate (CAR) rate-limiting QoS to the input of the output queue, 1 to 2 percent packet loss for UDP packets at  $10^{-6}$  BER was obtained.



For QoS techniques and commands see:

Policing and Shaping Overview

[http://www.cisco.com/univercd/cc/td/doc/product/software/ios120/12cgcr/qos\\_c/qcpart4/qcpolts.htm](http://www.cisco.com/univercd/cc/td/doc/product/software/ios120/12cgcr/qos_c/qcpart4/qcpolts.htm)

Configuring Committed Access Rate

[http://www.cisco.com/univercd/cc/td/doc/product/software/ios120/12cgcr/qos\\_c/qcpart1/qccar.htm](http://www.cisco.com/univercd/cc/td/doc/product/software/ios120/12cgcr/qos_c/qcpart1/qccar.htm)

The results indicated that one can obtain theoretical UDP packet throughput using HDLC framing and NRZI encoding. In addition, CAR rate-limiting should be applied to the input of the output queue on the transmit portion of a WAN link (see appendix for UDP streaming test results).

## Demonstrations

A number of applications were run over the nominal and errored links to demonstrate the ease and extent to which Internet protocols and technologies can be utilized by the Shuttle and Space Station. The applications included telnet, secure shell (ssh), Web-base control, FTP, and VoIP. QoS techniques were also demonstrated.

Telnet and ssh were utilized routinely over the 1.2-second round-trip delay to setup and monitor equipment remotely. The space and ground portions of the ESTL network are located in different rooms. Use of telnet or ssh were used to set up the space side equipment from the ground side and visa versa. Telnet and ssh were able to operate even at  $10^{-5}$  BER. Because of the small packet sizes and small amount of data transfer, link efficiency is not an issue for telnet and ssh.

The tftp application used for testing TCP performance demonstrated the ability to transfer large files. FTP would result in similar performance. Thus, near-error-free links are required for good bandwidth efficiency when using FTP.

VoIP was demonstrated between the space and ground links. The VoIP demonstrated used with G729.R8 compression required 8 to 11 kbps data throughput in each direction when talking (22-kbps duplex). The VoIP also has silence suppression so that no information is transmitted if no one is speaking. NIC cards in the space and ground routers were connected to analog wireless phones. Calls could be made by simply dialing the assigned phone number. Standard VoIP configurations were used. The VoIP performed well at nominal settings. During one call, the return link was degraded until the phone line went dead. This link was then returned to the nominal state resulting in the still open phone line reestablishing connectivity on its own. VoIP also worked at  $10^{-5}$  BER including call setup and teardown. Operation over such poor links is possible because the packets are relatively small and the decompression technology can compensate for some dropped packets. Note,  $10^{-5}$  packet loss is a normal occurrence on a congested network.

Web-based control was demonstrated by remotely configuring the Cisco/Aironet wireless access points. The access points can be controlled and monitored using telnet or a standard Web browser.

A QoS test was done with VoIP and a file transfer running simultaneously. Two configurations were demonstrated. In the first configuration VoIP was given a precedence of 5 while a file transfer was give a precedence of 0. With VoIP having the higher priority process, the file transfer took longer than in case 2. No degradation in voice quality was apparent. In the second configuration, VoIP was given a precedence of 5 while a file transfer was given a precedence of 6. Here, the files transfer occurred more quickly while voice quality degraded with the sound breaking up periodically.

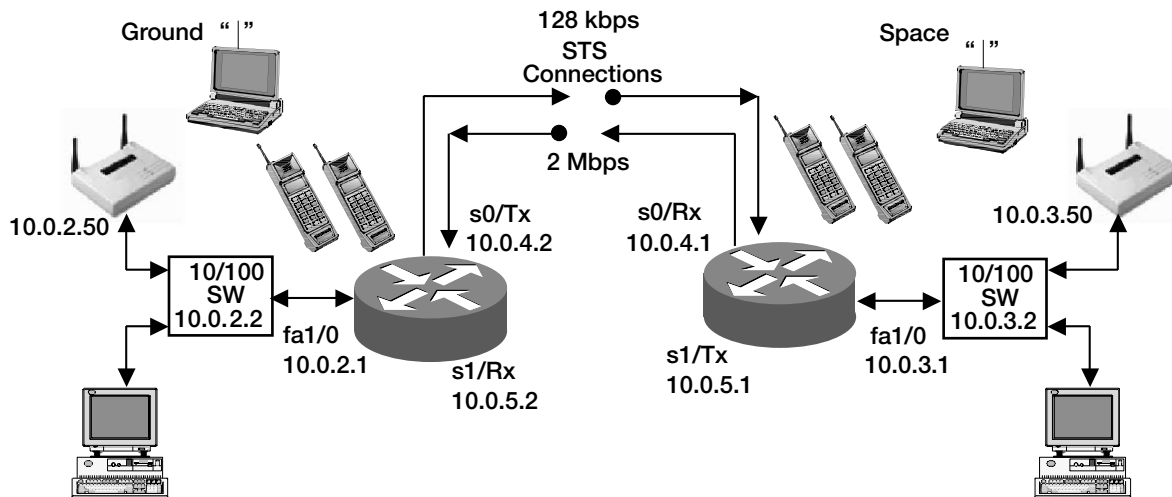

Figure 16.—Network topology supports multicast.

We attempted to run IPTV using the duplex routing over simplex links, but were unsuccessful to date. IPTV uses multicast protocols as the transport delivery protocol. As of May 2001, we have been unable to find a way to trick the simplex links to accept multicast protocol. One alternative, available only if the channel 2 FM or channel 3 FM circuits are used, is to apply only one serial interface on the WAN connection as shown in figure 16. The serial interface cards are capable of handling separate receive and transmit clock rates. The problem with this configuration, however, is that video is a high-rate application. Thus, one would much prefer to use the channel 3 PM, 48-Mbps link. The 48-Mbps link would require use of a high-speed serial interface (HSSI). HSSI interfaces use differential ECL levels. If the topology of figure 16 is used, proper level translation must be performed between the COTS HSSI interfaces and the NASA ground and space equipment.

Work is currently taking place in the commercial sector to develop routing protocols for networks with two separate asymmetric unidirectional links. These technologies directly apply to many NASA mission network topologies including the Shuttle and the Space Station.

## Conclusions

The results of the tests showed that a commercial off-the-shelf (COTS) router and standard TCP/IP protocols could be used for both the Shuttle and the Space Station even with delays of 1200 milliseconds as long as near-error-free radio links are provided. The results also show that high-level data link control (HDLC) framing works well for data links such as those provided by the Shuttle and the International Space Station. In addition, for systems that do not correct for phase ambiguity or do not perform scrambling at the data link layer, nonreturn to zero inverted (NRZI) encoding is mandatory. NRZI will perform the necessary scrambling and correct for phase ambiguity.

## Recommendations

Use of TCP can result in inefficient use of the bandwidth under congested or errored links with long bandwidth delay products. If, and only if, large files are being transferred often and if, and only if, you own and understand the dynamics and bandwidth allocations of the end-to-end network, a rate-based reliable file delivery protocol may be appropriate to deploy to improve link utilization.

Based on the results of this testing, it appears that NASA would be able to deploy COTS networking and communications equipment provided that resources were brought to bear to improve the current channel quality threshold of  $10^{-5}$  BER. The current architecture requires each user to adapt to this channel quality, which precludes the use of COTS and standard interfaces. Bringing the resources to bear to improve the channel quality to at least  $10^{-8}$  BER would allow NASA to utilize COTS networking and communication equipment and the TCP/IP protocol suite for both Shuttle and Space Station communications. Deployment of COTS and IP would significantly reduce costs, eliminate many interface control documents, and reduce development and testing time.



# APPENDIX

## Test Equipment

TABLE II.—TEST EQUIPMENT

QUANTITY	DESCRIPTION
2	Cisco 3640 router with 4 port serial card, VoIP card, 10/100 card
2	Cisco 2900 24-port 10/100 switch
1	Cisco IPTV broadcast server
1	Cisco IPTV control server
2	Adtech SX/14 Data Channel Simulator (to add delay)
2	Linux/Windows Laptop PC's with network performance tools
1	Laptop PC with IPTV client software loaded
2	Aironet Access Points (wireless Ethernet)
2	Wireless Ethernet PCMCIA cards (for laptops)
4	Analog telephones
1	VCR (video source)
1	PC monitor (for IPTV servers)
Numerous	Cables, adapters, and connectors

## Test Documentation

The test results and documentation are available on the Web at <http://ctd.lerc.nasa.gov/5610/relpres.html> as a compressed file. This tarball contains the tests performed at JSC and includes

- linux\_bin: The linux binary files for programs utilized to perform network testing.
- misc: misc files including Excel spreadsheets, PowerPoint presentations, and MSWord Documents
- nov7: Test data run on Nov 7
- nov8: Test data run on Nov 8
- nov9: Test data run on Nov 9
- dec12: Test data run on Dec 12 identifying and correcting 70 percent UPD packet loss at  $10^{-6}$  BER
- router\_configurations: router configurations used for the tests
- scripts: script files used for the tests
- scr: Source file of the programs utilized to perform network testing
- test\_data\_files: test data files

## High-Level Data Link Control (HDLC)

High-level data link control, also known as HDLC (ref. 4), is a bit-oriented data link control protocol, and falls within layer 2, the data link layer, of the open systems interface (OSI) model.

HDLC is a protocol developed by the International Organization for Standardization (ISO) under the ISO standards ISO 3309 and ISO 4335. It supports both half-duplex and full-duplex communication lines, point-to-point (peer-to-peer) and multipoint networks, and switched or non-switched channels. The procedures outlined in HDLC are designed to permit synchronous, code-transparent data transmission. Other benefits of HDLC are that the control information is always in the same position, and specific bit patterns used for control differ dramatically from those in representing data, which reduces the chance of errors.



## UDP Testing Script

```
#!/bin/tcsh
#This script takes a file port a file into tcp for UDP transmission
# command is udp_stream count host file
# count = the number of times the file should be sent
# host = hostname or IP address of the receiving host
# file = the file to be redirected into tcp
#
# tcp -u -l1440 -b300000 $2 < $3
#The tcpdump filename is the 1st and only parameter input and is required.
#
#
echo "There will be $1 sets of tcp UDP file transfers"
set cnt = $1
while ( $cnt >= 1 )
echo "This is a run $cnt counting down"
set cnt = `expr $cnt - 1`
tcp -t -u -l1440 -b300000 $2 < $3
    while ( "`ps -a | grep tcp`" != "" )
        end
    end
echo "DONE"
```

## Router Configurations

Some subtle key-routing configurations and commands that are required to make simplex routing over duplex links work properly include

- Use "static routes" on simplex links
- Use "no keep-alive" on simplex links
- Use "ignore-dcd" on DTE interface (be sure cables are connected first!)
- Set "clock rate" on DCE interfaces
- Use NRZI encoding. It solves all 0's, all 1's, and phase ambiguity problems.
- Use HDLC framing.
- Use the "transmit" command on the receiving interface to transmit on the sending interface.
  - int S1(Rx)
  - transmit int S0(Tx)

```
=====
SHUTTLE ROUTER - named "columbia"
```

```
columbia1#sho conf
Using 1508 out of 129016 bytes
!
version 12.0
service timestamps debug uptime
service timestamps log uptime
no service password-encryption
!
```

```

hostname columbia1
!
enable password cisco
!
!
!
!
!
ip subnet-zero
no ip domain-lookup
!
ip multicast-routing
ip dvmrp route-limit 20000
ip audit notify log
ip audit po max-events 100
cns event-service server
!
!
!
!
voice-port 2/0/0
!
voice-port 2/0/1
!
dial-peer voice 1 pots
destination-pattern 456
port 2/0/0
!
dial-peer voice 10 voip
destination-pattern 123
session target ipv4:10.0.2.1
!
dial-peer voice 2 pots
destination-pattern 258
port 2/0/1
!
dial-peer voice 20 voip
destination-pattern 147
session target ipv4:10.0.2.1
!
process-max-time 200
!
interface Serial0/0
transmit-interface Serial0/1
ip address 10.0.4.1 255.255.255.0
nrzi-encoding
no ip directed-broadcast
ip pim dense-mode
no ip mroute-cache

```



```
no keepalive
ignore-dcd
!
interface Serial0/1
ip address 10.0.5.1 255.255.255.0
nrzi-encoding
no ip directed-broadcast
ip pim dense-mode
no keepalive
clockrate 2015232
!
interface Serial0/2
no ip address
no ip directed-broadcast
shutdown
!
interface Serial0/3
no ip address
no ip directed-broadcast
no keepalive
clockrate 128000
!
interface FastEthernet1/0
ip address 10.0.3.1 255.255.255.0
no ip directed-broadcast
speed 10
!
interface Hssi3/0
no ip address
no ip directed-broadcast
shutdown
!
ip classless
ip route 10.0.0.0 255.0.0.0 Serial0/1
no ip http server
!
!
!
line con 0
password cisco
transport input none
line aux 0
line vty 0 4
password cisco
login
!
!
end
```

=====

**GROUND ROUTER – named “quest”**

```
quest1#sho conf
Using 1490 out of 129016 bytes
!
version 12.0
service timestamps debug uptime
service timestamps log uptime
no service password-encryption
!
hostname quest1
!
enable password cisco
!
!
!
!
ip subnet-zero
no ip domain-lookup
!
ip multicast-routing
ip dvmrp route-limit 20000
ip audit notify log
ip audit po max-events 100
cns event-service server
!
!
!
!
voice-port 2/0/0
!
voice-port 2/0/1
!
dial-peer voice 1 pots
destination-pattern 123
port 2/0/0
!
dial-peer voice 10 voip
destination-pattern 456
session target ipv4:10.0.3.1
!
dial-peer voice 2 pots
destination-pattern 147
port 2/0/1
!
dial-peer voice 20 voip
destination-pattern 258
```

```
session target ipv4:10.0.3.1
!
process-max-time 200
!
interface Serial0/0
ip address 10.0.4.2 255.255.255.0
nrzi-encoding
no ip directed-broadcast
ip pim dense-mode
no ip mroute-cache
no keepalive
ignore-dcd
!
interface Serial0/1
transmit-interface Serial0/0
ip address 10.0.5.2 255.255.255.0
nrzi-encoding
no ip directed-broadcast
ip pim dense-mode
no keepalive
ignore-dcd
!
interface Serial0/2
no ip address
no ip directed-broadcast
shutdown
!
interface Serial0/3
no ip address
no ip directed-broadcast
shutdown
!
interface FastEthernet1/0
ip address 10.0.2.1 255.255.255.0
no ip directed-broadcast
speed 100
full-duplex
!
interface Hssi3/0
no ip address
no ip directed-broadcast
shutdown
!
ip classless
ip route 10.0.0.0 255.0.0.0 Serial0/0
no ip http server
!
!
```

```

!
line con 0
password cisco
transport input none
line aux 0
line vty 0 4
password cisco
login
!
!
end

```

## UDP Streaming Test Results for December 12, 2000

The following are two test results. Rate limiting was set at 1896000 bps. BER was  $10^{-6}$  binominal distribution. In trial 1, no rate limiting was performed. For this short test, packet loss was approximately 78 percent with 17876 packets transmitted and 2367 received. For trial 2, we rate-limited at the input queue of the output buffer. Note, there still was 100 Mbps of data coming into the rate-limiting queue. The packet loss was approximately 2.4 percent with 7397 packets transmitted and 7213 received.

Conclusions:

- HDLC and NRZI perform well even in simplex link.
- The router can only take so much abuse in one functional location or it is overloaded. Therefore, use rate-limiting on the input of the output queues for noncongestion friendly traffic such as UDP.

```

+++++
Router processor can only do so much.
We need to rate-limit UDP traffic and everything works!
+++++

```

Space router cfg details

```

!
access-list 101 permit udp any any eq 5001

```

ip cef

```

interface Serial0/1
ip address 10.0.5.1 255.255.255.0
no ip directed-broadcast
ip accounting access-violations
ip pim dense-mode
rate-limit output access-group 101 1896000 10000 30000 conform-action transmit exceed-action drop
no keepalive
nrzi-encoding
clockrate 2015232
no cdp enable

```

Trial 1 (no rate limit for port 5432)

---

```
[ivancic@katrinajoy dec12]$ tcp -u -s -t -11440 -b300000 -n5000000 10.0.2.200 -p5432
```

```
space#sho int s0/1
Serial0/1 is up, line protocol is up
Hardware is M4T
Internet address is 10.0.5.1/24
MTU 1500 bytes, BW 1544 Kbit, DLY 20000 usec,
  reliability 255/255, txload 128/255, rxload 1/255
Encapsulation HDLC, crc 16, loopback not set
Keepalive not set
Last input never, output 00:00:08, output hang never
Last clearing of "show interface" counters 00:02:33
Input queue: 0/75/0 (size/max/drops); Total output drops: 589211
Queueing strategy: weighted fair
Output queue: 0/1000/64/589211 (size/max total/threshold/drops)
  Conversations 0/2/256 (active/max active/max total)
  Reserved Conversations 0/0 (allocated/max allocated)
5 minute input rate 0 bits/sec, 0 packets/sec
5 minute output rate 780000 bits/sec, 62 packets/sec
 0 packets input, 0 bytes, 0 no buffer
  Received 0 broadcasts, 0 runts, 0 giants, 0 throttles
 0 input errors, 0 CRC, 0 frame, 0 overrun, 0 ignored, 0 abort
17876 packets output, 26300540 bytes, 0 underruns
 0 output errors, 0 collisions, 0 interface resets
 0 output buffer failures, 0 output buffers swapped out
 0 carrier transitions DCD=up DSR=up DTR=up RTS=up CTS=up
ground#sho int s0/1
Serial0/1 is up, line protocol is up
Hardware is M4T
Internet address is 10.0.5.2/24
MTU 1500 bytes, BW 1544 Kbit, DLY 20000 usec,
  reliability 192/255, txload 1/255, rxload 27/255
Encapsulation HDLC, crc 16, loopback not set
Keepalive not set
Transmit interface is Serial0/0
Last input 00:00:07, output never, output hang never
Last clearing of "show interface" counters 00:01:50
Input queue: 0/75/0 (size/max/drops); Total output drops: 0
Queueing strategy: weighted fair
Output queue: 0/1000/64/0 (size/max total/threshold/drops)
  Conversations 0/0/256 (active/max active/max total)
  Reserved Conversations 0/0 (allocated/max allocated)
5 minute input rate 217000 bits/sec, 7 packets/sec
5 minute output rate 0 bits/sec, 0 packets/sec
2367 packets input, 3478486 bytes, 0 no buffer
  Received 0 broadcasts, 0 runts, 0 giants, 0 throttles
14419 input errors, 14416 CRC, 0 frame, 0 overrun, 0 ignored, 3 a
bort
 0 packets output, 0 bytes, 0 underruns
 0 output errors, 0 collisions, 0 interface resets
 0 output buffer failures, 0 output buffers swapped out
```

```
0 carrier transitions DCD=up DSR=up DTR=up RTS=up CTS=up
space#sho interfaces rate-limit
Serial0/1
Output
matches: access-group 101
params: 1896000 bps, 10000 limit, 30000 extended limit
conformed 0 packets, 0 bytes; action: transmit
exceeded 0 packets, 0 bytes; action: drop
last packet: 714104ms ago, current burst: 28564 bytes
last cleared 00:00:52 ago, conformed 0 bps, exceeded 0 bps
```

Trial 2 (rate limit for port 5001)

---

```
[ivancic@katrinajoy dec12]$ tcp -u -s -t -l1440 -b300000 -n5000000 10.0.2.200 -p5001
```

```
space#sho int s0/1
Serial0/1 is up, line protocol is up
Hardware is M4T
Internet address is 10.0.5.1/24
MTU 1500 bytes, BW 1544 Kbit, DLY 20000 usec,
reliability 255/255, txload 81/255, rxload 1/255
Encapsulation HDLC, crc 16, loopback not set
Keepalive not set
Last input never, output 00:00:02, output hang never
Last clearing of "show interface" counters 00:02:16
Input queue: 0/75/0 (size/max/drops); Total output drops: 256470
Queueing strategy: weighted fair
Output queue: 0/1000/64/0 (size/max total/threshold/drops)
Conversations 0/2/256 (active/max active/max total)
Reserved Conversations 0/0 (allocated/max allocated)
5 minute input rate 0 bits/sec, 0 packets/sec
5 minute output rate 491000 bits/sec, 30 packets/sec
0 packets input, 0 bytes, 0 no buffer
Received 0 broadcasts, 0 runts, 0 giants, 0 throttles
0 input errors, 0 CRC, 0 frame, 0 overrun, 0 ignored, 0 abort
7397 packets output, 10876892 bytes, 0 underruns
0 output errors, 0 collisions, 0 interface resets
0 output buffer failures, 0 output buffers swapped out
0 carrier transitions DCD=up DSR=up DTR=up RTS=up CTS=up
```

```
ground#sho int s0/1
Serial0/1 is up, line protocol is up
Hardware is M4T
Internet address is 10.0.5.2/24
MTU 1500 bytes, BW 1544 Kbit, DLY 20000 usec,
reliability 191/255, txload 1/255, rxload 44/255
Encapsulation HDLC, crc 16, loopback not set
Keepalive not set
Transmit interface is Serial0/0
Last input 00:00:20, output never, output hang never
Last clearing of "show interface" counters 00:04:19
Input queue: 0/75/0 (size/max/drops); Total output drops: 0
```

Queueing strategy: weighted fair  
 Output queue: 0/1000/64/0 (size/max total/threshold/drops)  
 Conversations 0/0/256 (active/max active/max total)  
 Reserved Conversations 0/0 (allocated/max allocated)  
 5 minute input rate 271000 bits/sec, 22 packets/sec  
 5 minute output rate 0 bits/sec, 0 packets/sec  
 7213 packets input, 10598850 bytes, 0 no buffer  
 Received 0 broadcasts, 0 runts, 0 giants, 0 throttles  
 580 input errors, 578 CRC, 0 frame, 0 overrun, 0 ignored, 2 abort  
 0 packets output, 0 bytes, 0 underruns  
 0 output errors, 0 collisions, 0 interface resets  
 0 output buffer failures, 0 output buffers swapped out  
 0 carrier transitions DCD=up DSR=up DTR=up RTS=up CTS=up

```
space#sho int s0/1 rate-limit
Serial0/1
Output
matches: access-group 101
params: 1896000 bps, 10000 limit, 30000 extended limit
conformed 7390 packets, 10876644 bytes; action: transmit
exceeded 256470 packets, 377523840 bytes; action: drop
last packet: 77128ms ago, current burst: 29592 bytes
last cleared 00:03:07 ago, conformed 462000 bps, exceeded 16069000 bps
```

## Test Personnel

**Researchers:** W. Ivancic and T. Bell, NASA Glenn Research Center, and D. Shell, Cisco Systems

**QUEST (ESTL Test Sponsor):** P. Carreon, NASA Johnson Space Center Code DV2

**ESTL Test Team Members:**

Test Director	C.A. Lansdowne
Test Conductor	T.B. Jenkins
ESTL Senior Test Engineers	P.D. Hangsleben/F.T. Shetz, Jr.
Test Project Engineers (TPE)	G.L. McKinney
Test Data Coordinator	K.J. Jolley
Quality Assurance Specialist	D.P. Bette

**ESTL Area Engineers:**

CT&RA	P.R. Flores
ESTGT	P.I. Yamaguchi
SEN-1	F.J. Ward
SITA	A.F. Buchanan
TCC-1	P.D. Hangsleben
SLSA	H.M. Ponder, Jr.

**ESTL Systems Support (as required):**

ESTL Intercom System	F.T. Shetz, Jr.
EMACS/EDS	F.R. Sims
Test Technician/Backup	S.L. Connaly/I.A. Vences

## References

1. M. Mathis, J. Mahdavi, S. Floyd, and A. Romanow: TCP Selective Acknowledgement Options. RFC 2018, Oct. 1996.
2. V. Jacobson, R. Braden, and D. Borman: TCP Extensions for High Performance. RFC 1323, May 1992.
3. DBS: Distributed Benchmark System <http://shika.aist-nara.ac.jp/member/yukio-m/dbs/index.html>
4. <http://members.tripod.com/~vkalra/hdlc.html>



**REPORT DOCUMENTATION PAGE**Form Approved  
OMB No. 0704-0188

Public reporting burden for this collection of information is estimated to average 1 hour per response, including the time for reviewing instructions, searching existing data sources, gathering and maintaining the data needed, and completing and reviewing the collection of information. Send comments regarding this burden estimate or any other aspect of this collection of information, including suggestions for reducing this burden, to Washington Headquarters Services, Directorate for Information Operations and Reports, 1215 Jefferson Davis Highway, Suite 1204, Arlington, VA 22202-4302, and to the Office of Management and Budget, Paperwork Reduction Project (0704-0188), Washington, DC 20503.

<b>1. AGENCY USE ONLY (Leave blank)</b>		<b>2. REPORT DATE</b> April 2002	<b>3. REPORT TYPE AND DATES COVERED</b> Technical Memorandum	
<b>4. TITLE AND SUBTITLE</b>  ISS and STS Commercial Off-The-Shelf Router Testing			<b>5. FUNDING NUMBERS</b>  WU-322-20-2A-00	
<b>6. AUTHOR(S)</b>  William D. Ivancic, Terry L. Bell, and Dan Shell				
<b>7. PERFORMING ORGANIZATION NAME(S) AND ADDRESS(ES)</b>  National Aeronautics and Space Administration John H. Glenn Research Center at Lewis Field Cleveland, Ohio 44135-3191			<b>8. PERFORMING ORGANIZATION REPORT NUMBER</b>  E-13112	
<b>9. SPONSORING/MONITORING AGENCY NAME(S) AND ADDRESS(ES)</b>  National Aeronautics and Space Administration Washington, DC 20546-0001			<b>10. SPONSORING/MONITORING AGENCY REPORT NUMBER</b>  NASA TM-2002-211310	
<b>11. SUPPLEMENTARY NOTES</b>  William D. Ivancic, NASA Glenn Research Center, Cleveland, Ohio; Terry L. Bell, Lockheed Martin Global Telecommunications, Cleveland, Ohio 44135; Dan Shell, Cisco Systems, San Jose, California 95134-1706. Responsible person, William D. Ivancic, organization code 5610, 216-433-3494.				
<b>12a. DISTRIBUTION/AVAILABILITY STATEMENT</b>  Unclassified - Unlimited Subject Categories: 17, 61, and 62 Available electronically at <a href="http://gltrs.grc.nasa.gov/GLTRS">http://gltrs.grc.nasa.gov/GLTRS</a> This publication is available from the NASA Center for AeroSpace Information, 301-621-0390.			<b>12b. DISTRIBUTION CODE</b>	
<b>13. ABSTRACT (Maximum 200 words)</b>  This report documents the results of testing performed using commercial off-the-shelf (COTS) routers and Internet Protocols (IP's) to determine if COTS equipment and IP could be utilized to upgrade NASA's current Space Transportation System (STS), the Shuttle, and the International Space Station communication infrastructure. Testing was performed by NASA Glenn Research Center (GRC) personnel within the Electronic Systems Test Laboratory (ESTL) with cooperation from the Mission Operations Directorate (MOD) Qualification and Utilization of Electronic System Technology (QUEST) personnel. The ESTL testing occurred between November 1 and 9, 2000. Additional testing was performed at NASA Glenn Research Center in a laboratory environment with equipment configured to emulate the STS. This report documents those tests and includes detailed test procedures, equipment interface requirements, test configurations and test results. The tests showed that a COTS router and standard Transmission Control Protocols and Internet Protocols (TCP/IP) could be used for both the Shuttle and the Space Station if near-error-free radio links are provided.				
<b>14. SUBJECT TERMS</b>  Satellite; Network; Coding			<b>15. NUMBER OF PAGES</b> 40	
			<b>16. PRICE CODE</b>	
<b>17. SECURITY CLASSIFICATION OF REPORT</b> Unclassified	<b>18. SECURITY CLASSIFICATION OF THIS PAGE</b> Unclassified	<b>19. SECURITY CLASSIFICATION OF ABSTRACT</b> Unclassified	<b>20. LIMITATION OF ABSTRACT</b>	