

Space Shuttle Landing and Rollout Training at the Vertical Motion Simulator

Steven D. Beard¹

NASA Ames Research Center, Moffett Field, CA 94035

Leslie A. Ringo²

NASA Johnson Space Center, Houston, TX 77058

Brian Mader³

United Space Alliance, LLC, Houston, TX 77058

Estela H. Buchmann⁴

SAIC, Moffett Field, CA 94035

and

Thomas Tanita⁵

Boeing Space Exploration, Houston, TX 77058

Landing and rollout training at the NASA Ames Research Center Vertical Motion Simulator (VMS) has been an integral part of the Shuttle Program for almost thirty years. The VMS is a unique, high-fidelity, large amplitude, six degree of freedom motion simulator. It is used for this training as well as for engineering evaluations because its large motion envelope, high-fidelity cockpit, and visuals accurately simulates the motion and visual cueing environments of the Shuttle Orbiter during the touchdown and rollout phase of flight. Training sessions in the VMS are held semi-annually with each session containing unique objectives related to specific mission profiles and maintaining pilot training currency under nominal and off-nominal conditions. The VMS has also been used as the test bed for evaluating the effects of engineering and operational changes implemented by the Shuttle Program to improve the safety and operation of the Orbiter. Throughout the program, the continuous review of simulation models and results has led to systematic improvements to the simulation.

I. Introduction

The National Space Transportation System Requirements identifies NASA Ames Research Center as the Center responsible for the Vertical Motion Simulator (VMS) and outlines the requirement for the VMS to meet the Shuttle Program objectives as “a design evaluation tool for manual monitoring and control of Orbiter flight phases including landing and rollout.”¹ Known potential hazards exist in the landing and rollout, which are documented in the Shuttle Program Hazard Reports. These Hazard Reports define crew training at the VMS as one of the controls to mitigate potential catastrophic consequences in the landing scenario². This is one reason why the Ames VMS is a valued tool for Astronaut pilot training.

In meeting those requirements, the VMS has provided Shuttle landing and rollout training and engineering evaluations for almost three decades. Since the first engineering study simulation that took place in the VMS in

¹ Simulation Engineer, Aerospace Simulation Operations Branch, MS 243-1.

² Chief Engineer, Astronaut Office, Johnson Space Center, 2101 NASA Road One, Houston, TX 77058.

³ Engineering Staff Ascent/Decent Flight Design, United Space Alliance, LLC, Houston, TX 77058.

⁴ Simulation Engineer, SAIC, NASA Ames Research Center, MS 243-6.

⁵ Shuttle Entry FCS Analyst, Boeing Space Exploration, 13100 Space Center Boulevard, HM5-20.

April 1980, more than 65,000 training and engineering runs have been performed. All Orbiter pilots have trained in the VMS prior to their missions.

The VMS has been an important development tool for the Shuttle Program. Unlike most new aircraft development programs that have extensive and rigorous flight test programs prior to becoming “operational,” the Shuttle Program only had five free flight landings during the approach and landing tests prior to the first Shuttle mission. To date, the Shuttle Program has had 121 successful mission landings. As a result of the low number of flights, the VMS has carried the burden that would normally be borne by flight testing. The VMS has also been used as the test bed for determining the effects of various engineering and operational changes implemented by the Shuttle Program on pilot-in-the-loop handling qualities. To date there have been more than 80 Shuttle engineering studies performed on the VMS.

The VMS is a unique, high-fidelity, large amplitude, six degree of freedom motion flight simulator. The large motion envelope of the VMS accurately simulates the touchdown and rollout motion cueing environment necessary for positive transfer of training from the simulator to the actual vehicle. Training simulations in the VMS are held semi-annually, with each session containing unique objectives related to the mission profiles and maintaining pilot training currency for various conditions including emergency landings, challenging environmental conditions, and system failures. The system architecture in the VMS is flexible by design and allows integration of external software modules and unique vehicle-specific hardware. This has enabled the Shuttle Program to use the VMS to develop, test, and evaluate numerous changes that have improved the safety and operation of the Orbiter.

The use of the VMS for landing and rollout training was an outgrowth of its early use to investigate and remedy handling quality issues. The first Shuttle simulation on the VMS investigated a pilot induced oscillation (PIO) the Orbiter encountered during approach and landing tests.³ Prior to use of the VMS, the Ames Flight Simulator for Advanced Aircraft (FSAA) was used for the PIO testing but did not provide the vertical motion cues with enough fidelity to recreate the PIO. When the VMS became operational in 1980, this test was repeated, and the VMS was able to recreate the motion fidelity (primarily vertical cues) necessary to reproduce the PIO. From this time, the VMS has been used extensively by the Shuttle Program for engineering studies as well as pilot training.

Landing and rollout is defined as the phase of flight from Mach 0.95 to touchdown where the Shuttle Commander manually flies the Orbiter. This is a demanding task in many ways. First, the flight crew have been in micro gravity conditions for some length of time and are adapting from prolonged weightlessness to earth’s gravity during approach and landing. Second, the Space Shuttle Orbiter entry flight control system is a three axis rate command feedback control system designed to deal with the changing aerodynamics due to its wide range of environments. This requires years of training by pilots to perfect the precision, small amplitude, low gain input flying required to perform a safe landing.⁴ Lastly, the rapidly decelerating approach and landing profile is unlike any other aircraft and, because it is unpowered, it must be done correctly on the first attempt. For these reasons, the training on the two high-fidelity landing simulators available to the Astronaut Corps, the VMS and the Shuttle Training Aircraft (STA), is critical.

A. The Landing and Rollout Task

The majority of the VMS training is for the approach and landing phase starting at 10,000 ft altitude and ending when the Orbiter comes to a stop following touchdown. The approach and landing segments are illustrated in Fig. 1. During a nominal approach for a lightweight Orbiter, the vehicle is on the outer glide slope (OGS) at an angle of 20 degrees and will transition to a 1.5 degree inner glide slope (IGS). The Shuttle Commander targets a touchdown of the main gear at 195 kts. Once below 120 kts, the Commander will initiate braking until wheel stop.

The STA is a heavily modified Gulfstream II business jet that simulates the handling qualities of the actual Orbiter. It is used to train the Astronaut pilots for approach. STA training runs begin at approximately 35,000 ft and end when the pilot’s eye height is approximately 32 ft above the runway - the same location it would be for an actual Orbiter touchdown. Since the STA is a smaller aircraft than the Shuttle and has a lower pilot eye point upon landing, the training run is completed without the STA touching down. The VMS training is, therefore, the only time, other than in the actual Orbiter, that a Shuttle Commander can “feel” what it is like to touchdown in the Orbiter and practice braking and steering during rollout. The VMS is also used to train pilots on various environmental conditions (such as crosswinds), tire failures, chute failures, and navigational errors without endangering the crew or Orbiter.

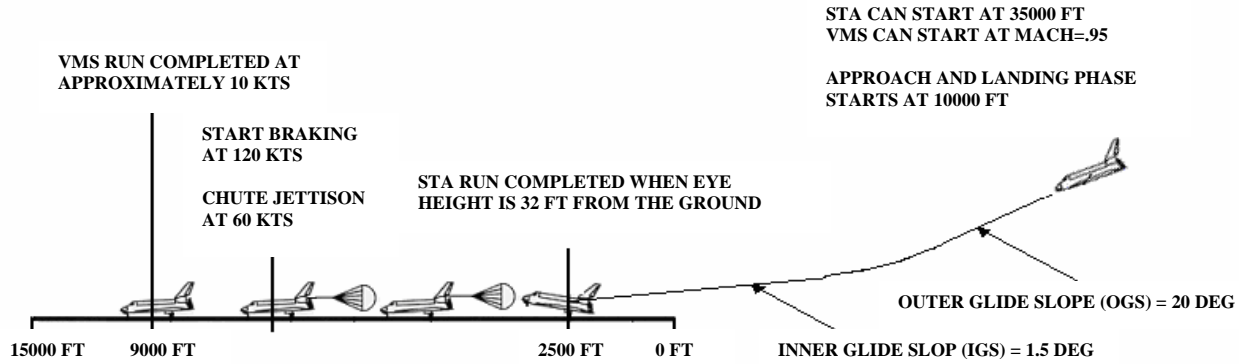

Figure 1. Approach and Landing Task Profile for Light Weight Orbiter

II. Description of the VMS

The VMS combines a high-fidelity simulation capability with an adaptable environment that allows the customization to a wide variety of pilot-in-the-loop research applications. The distinctive feature of the VMS is its unparalleled large amplitude high-fidelity motion capability. The high level of simulation fidelity is achieved by combining this motion fidelity with excellent visual and cockpit interface fidelities. An interchangeable cab arrangement allows different crew vehicle interfaces and vehicle types to be evaluated allowing fast turnaround times between simulation projects. The VMS motion system supplies six degrees of freedom via a combined electro-mechanical/electro-hydraulic servo system, shown in Fig. 2. It is located in, and partially supported by, a specially constructed 120 ft tower. The motion platform consists of a 40 ft long beam that travels ± 30 ft vertically. On top of the beam is a carriage that traverses the 40 ft length of the beam. A sled sits atop the carriage providing ± 4 ft of travel in a third translational degree of freedom. A conically shaped structure is mounted on the sled and rotates about the vertical axis providing yaw motion. A two-axis gimbal allows pitch and roll motion. The Interchangeable Cab (ICab) is attached to the top gimbal ring. The motion capability of the VMS is summarized in Table 1.

The ICab capability in the VMS allows the cockpit to be tailored to the research application. The VMS has five portable ICabs with different out-the-window (OTW) visual fields-of-view. One cab is dedicated to the Space Shuttle Program. The Orbiter cab, or S-Cab (shown in Fig. 3), has a 135-degree OTW field-of-view, representative cockpit displays including the head-up display (HUD), and actual Shuttle rotational hand controllers. McFadden hydraulic force loader systems are used for the brake/rudder pedals.

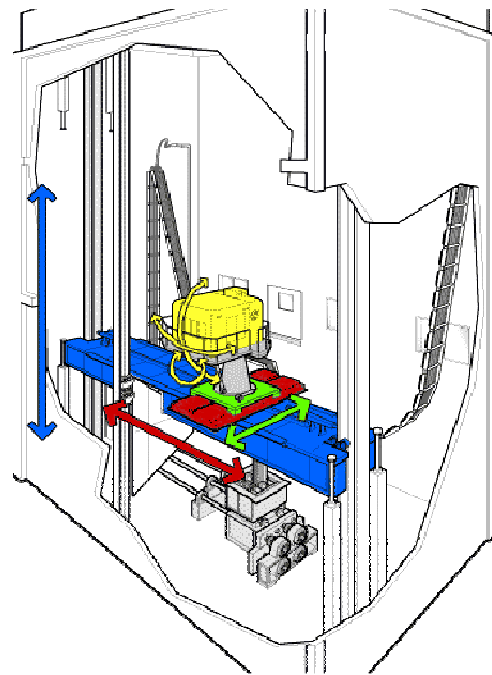

Figure 2. Cutaway Diagram of the VMS Facility

Table 1. VMS Motion Capability

VMS NOMINAL OPERATIONAL MOTION LIMITS			
Axis	Displacement (ft)	Velocity (ft/sec)	Acceleration (ft/sec ²)
Vertical	±30	16	24
Lateral	±20	8	16
Longitudinal	±4	4	10
	(deg)	(deg/sec)	(deg/sec ²)
Roll	±18	40	115
Pitch	±18	40	115
Yaw	±24	46	115

All the essential elements of the simulation are linked with the host environment through a dedicated network and controlled through a fully equipped control room. The flexible simulation architecture makes it convenient to interface with and evaluate custom software and hardware in the loop on the VMS.⁵ This capability has been used for the Shuttle simulation to integrate the Orbiter brake antiskid electronic control unit hardware.



Figure 3. Space Shuttle ICab Cockpit in the VMS

III. History of Shuttle Training and Development on the VMS

A. Evolution of the Shuttle Simulation

Over the course of 30 years, the Shuttle simulation has changed significantly. When the Shuttle simulation first started, the OTW graphics were generated using a terrain board with a camera on an X-Y table (Fig. 4).



Figure 4. Terrain Board

As computer technology improved, the terrain board was replaced with a computer image generator (IG) that produced the OTW scene. The IG has been upgraded four times since replacing the terrain board; the latest IG and display upgrade took place in February 2008. The previous ESIG-3000 IG was replaced with a state-of-the-art EPX-5000 IG (Fig. 5). The displays were also upgraded from CRT interlaced monitors to higher resolution projectors.

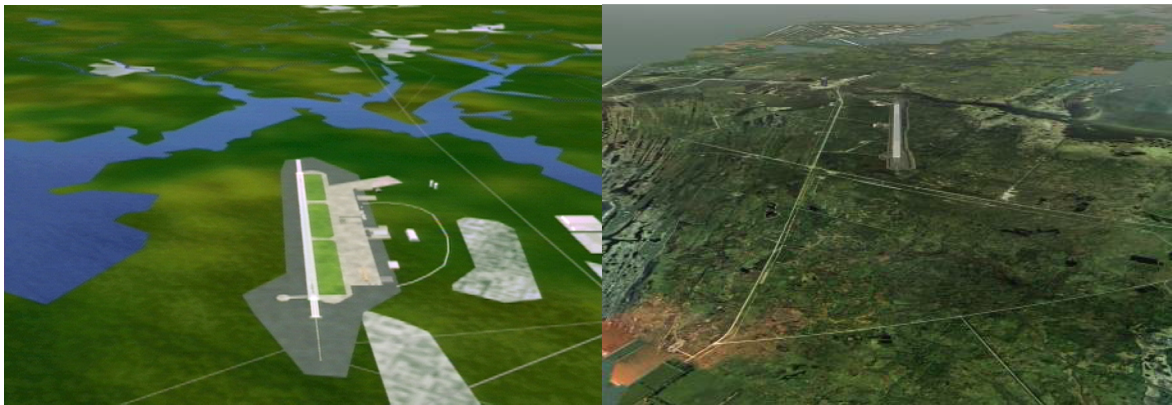

Figure 5. Comparison of the ESIG-3000 and the EPX-5000 Image Generators

The Shuttle ICab cockpit has had two major upgrades over time. The first major upgrade took place prior to the Multifunction Electronic Display Subsystem (MEDS) upgrade to Space Shuttle Orbiter Atlantis in 1999. The MEDS upgrade replaced the cathode ray tube (CRT) displays and the electro-mechanical flight instruments in the actual Orbiter cockpits. As the MEDS upgrades were performed sequentially through the Orbiter fleet, the pilots needed to train on the new MEDS system as well as the old CRT displays and flight instruments. To meet this need, the Shuttle ICab cockpit at the VMS was redesigned to support both the old instruments (on the left Commander seat) and the MEDS configuration (on the right Pilot seat).

The second major VMS Shuttle ICab cockpit upgrade took place after the entire Shuttle fleet completed its MEDS upgrade. Both sides of the VMS Shuttle ICab cockpit were outfitted for MEDS. All heads down displays were upgraded to liquid crystal display (LCD) monitors. Other ICab improvements included a redesign of the pedal assembly to better emulate the actual Orbiter pedal assemblies. It is important to note that although the VMS Shuttle ICab cockpit design is not an exact physical replica of the Orbiter flight deck, it provides the same functionality for training the landing and rollout phase of flight. The displays, controls, and “windows” configurations required to provide quality landing and rollout training are merged together with the ICab physical dimension limitations. This results in the hybrid cockpit shown in Fig. 3.

When the Orbiter fleet upgraded to antiskid avionics in 1988, the VMS was given a spare antiskid electronic control unit that was integrated with the simulation. The actual antiskid unit adds to the fidelity of the braking simulation and is an essential component in braking studies.

Shuttle flight software, math models, and landing hardware system knowledge have been updated regularly throughout the history of the Shuttle Program. The VMS has incorporated these changes to continuously provide an up-to-date high-fidelity landing and rollout simulation. Flight software updates are defined by Operational Increment (OI) requirements. Approximately 27 updates have been incorporated into the Shuttle flight software over the past 30 years. The related landing task OI requirements have been incorporated into the VMS Orbiter model. High-fidelity wind, turbulence, and aero uncertainties models provide required inputs to the simulation.

Critical Math Models are defined to be those owned and under configuration control by the Orbiter Project in the Space Shuttle Program. These Critical Math Models capture the knowledge of the landing systems performance. As new testing and hardware are added to the Orbiter fleet, these Critical Math Models are updated to reflect appropriate changes in performance. Some significant models incorporated in the VMS simulation include:⁶

- Tire Load Sharing
- Main Gear Tire Compression
- Drag Chute
- Main Gear Side Energy
- Main and Nose Gear Normal Loads
- Main and Nose Gear Side Loads
- Main and Nose Gear Drag
- Auto and Beep Trim Derotation
- Nose Wheel Steering and Caster
- Gear Grind
- Roll on Rim
- Main Gear Tire Wear
- Carbon-Carbon Brakes
- Tire CP Shift Due to Braking
- Load Persistence
- Main Gear Tire Failure
- Runway Crown
- Main Gear Tire Spin Up
- Auxiliary Power Units

IV. Landing and Rollout Training

The Shuttle Commander manually flies the Orbiter during the phase of flight from Mach 0.95 to touchdown. This phase of flight encompasses subsonic Terminal Area Energy Management (TAEM) guidance and the Approach and Landing guidance. TAEM has four flight phases: S-turn, acquisition, heading alignment, and prefinal. Approach and Landing guidance has five segments: trajectory capture, outer glide slope (OGS), flare and shallow glide slope, final flare (FF), and touchdown and rollout.⁷

Orbiter landing simulators provide emulations of the heading alignment phase, also referred to as the heading alignment cone (HAC), to touchdown. The Orbiter will intercept the heading alignment cone and spiral down until it is lined up to begin the approach and landing phase (see Fig. 6). The approach and landing phase begins at 10,000 ft as the Shuttle begins a glide slope of 20 degrees for a light weight Orbiter. At approximately 2,000 ft the Orbiter will begin to transition to a 1.5 degree glide slope until the final flare and touchdown of the main gear targeted for 2,500 ft down the runway at a velocity of 195 kts (see Fig. 7). Shortly after touchdown of the main gear, the Pilot will deploy the drag chute. At a velocity of 185 kts, the Commander will derotate at 1.5 degrees/sec until the nose gear touches down. Braking commences after the Orbiter has decelerated below 120 kts. The Pilot will jettison the chute at 60 kts as the Commander brings the vehicle to wheel stop (see Fig. 8).

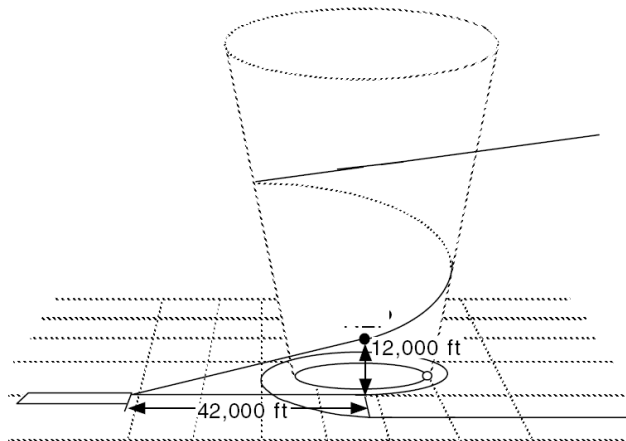

Figure 6. Heading Alignment Cone (HAC) Approach to Runway

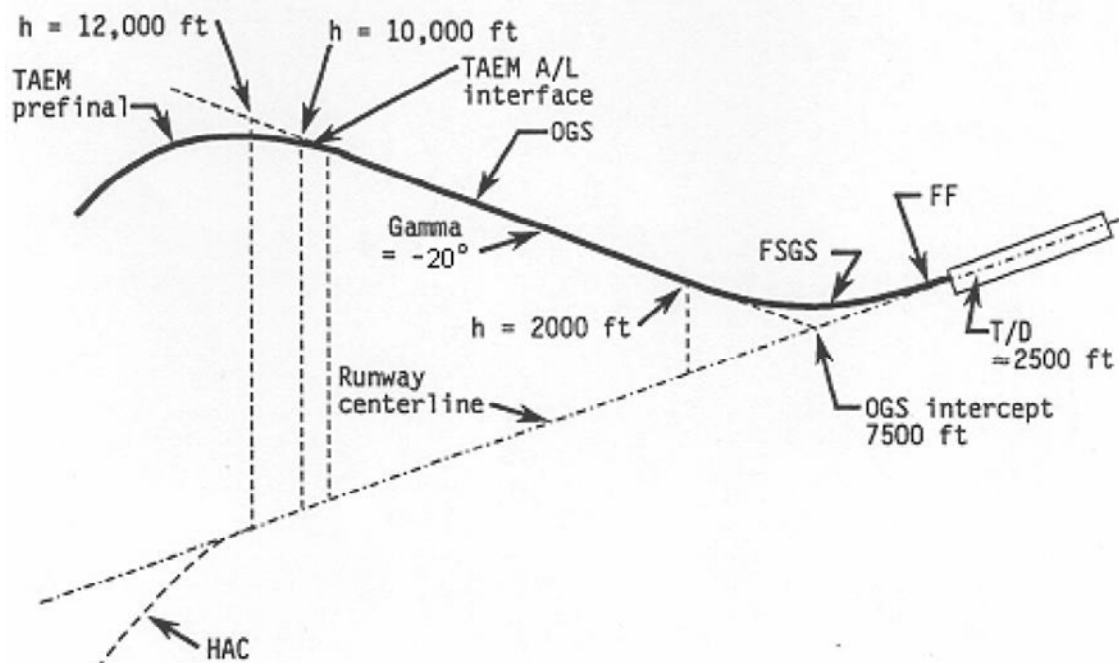

Figure 7. Approach and Landing Phase

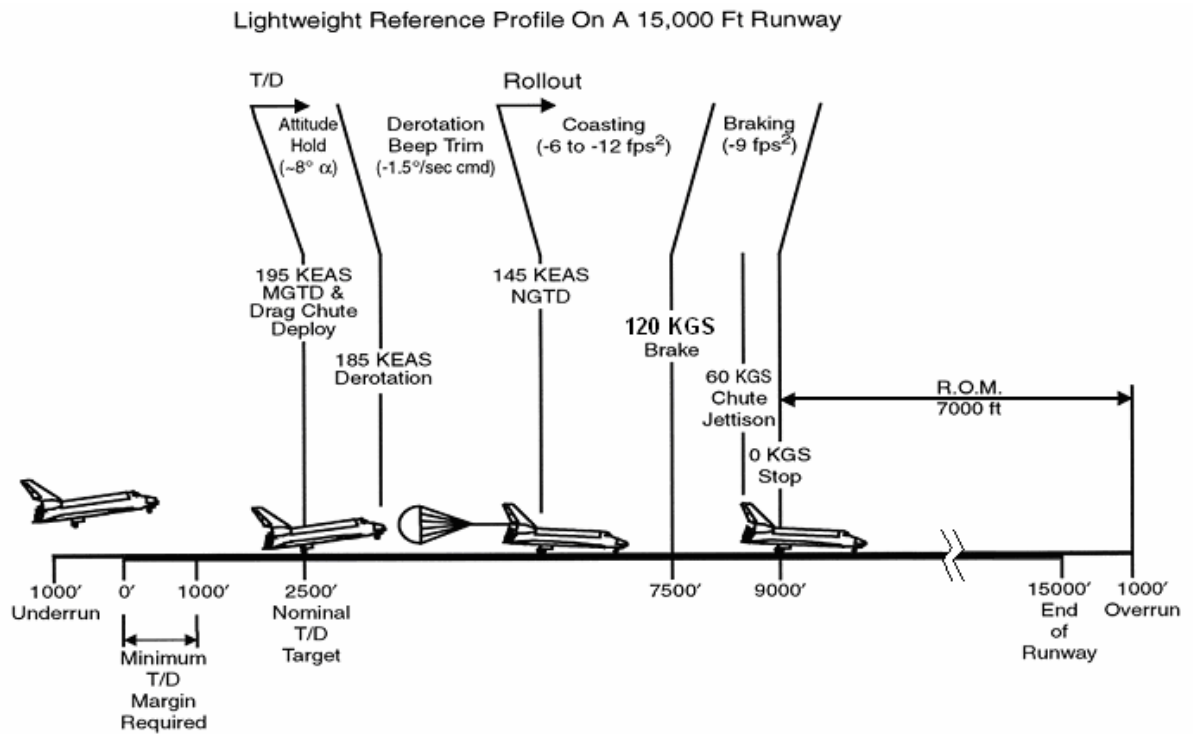

Figure 8. Rollout Representation for a Nominal Light Weight Orbiter

Each of the Shuttle landing simulators, either the VMS or the STA, is unique in its feel and fidelity to an actual Orbiter landing, so the flight crew blends their techniques from training sessions in each to maximize their preparedness for the actual Orbiter landing. Fig. 9 demonstrates how a Shuttle Commander's first nominal approach and landing both in the VMS and STA are representative of an actual Orbiter landing. The abscissa of Fig. 9 shows the distance down the runway, the positive ordinate axis represents the altitude, and the negative ordinate axis represents the rate of change in the altitude. It is difficult to directly compare each of the runs because conditions such as the wind, turbulence, and visibility are not the same for each. The Orbiter data is also more jagged because the data is only recorded at 1 Hz.

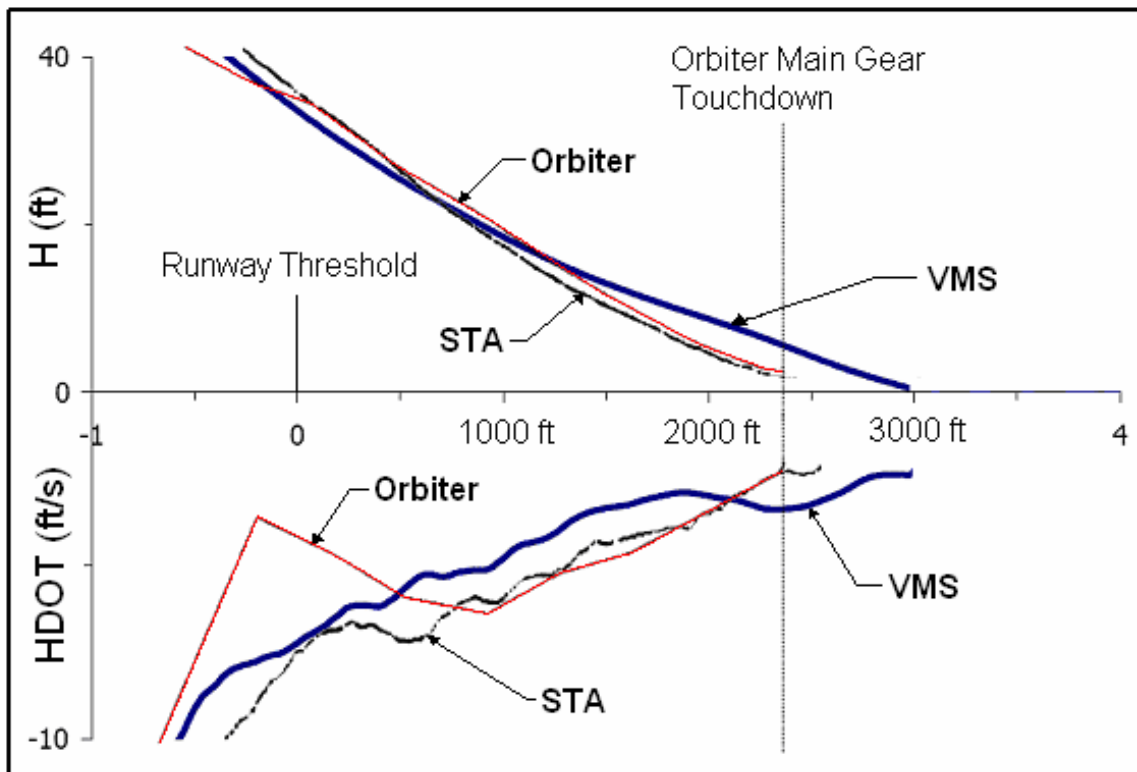

Figure 9. First Nominal End of Mission Approach and Landing on the VMS, STA, and the Orbiter

V. Training/Engineering Sessions

Early in the Shuttle Program the training and engineering sessions on the VMS lasted six weeks, with four weeks dedicated to engineering studies and two weeks to training. Engineering sessions were common, as enhancements were continuously pursued to improve the safety and operation of the Orbiter. Currently, as the Shuttle Program prepares to end in 2010, the focus remains on training with fewer engineering evaluations needed. To increase efficiency in the planning and running of a Shuttle simulation session, engineering studies are combined with training sessions.

The preparation for each training session starts months before the Astronaut pilots arrive at the VMS. The first and the most important step is the Astronaut Office defining the training objectives. The training objectives are then translated into a training matrix that defines the training scenario for each run. When the training matrix is completed, configuration of the simulation at the VMS can begin. A script file for each training run is made and the math model is verified prior to the start of the simulation. Lastly, the Shuttle simulation is run, the data collected and analyzed.

There are three development phases for any training and engineering simulation session. These phases consist of planning, the operational session, and post simulation wrap up. The principal team members in all phases of a VMS Shuttle simulation include NASA Ames VMS personnel, the NASA Johnson Space Center (JSC) Astronaut Office, JSC Engineering, United Space Alliance, LLC (USA), and Boeing Space Exploration.

VI. Planning Phase

A. Training Objectives

Several months prior to the start of each training session, the Astronaut Office defines a list of training objectives. The training objectives are designed to maintain pilot currency for the following landing conditions:⁸

- Nominal Landings, Return to Launch Site (RTL), Transoceanic Abort Landing (TAL), and East Coast Abort Landings (ECAL)
- Crew Resource Management
- Lateral Control Familiarization
- Runway Familiarization
- Single Auxiliary Power Unit (APU) Scenarios
- Tire Failures
- Beep Trim Failures
- Drag Chute Failures
- Antiskid Failures
- Backup Flight Software HUD Scenarios
- Navigational Offsets
- High Crosswind and Blown Forecasts
- Nose Wheel Steering (NWS) Fail/Hardover Conditions
- Close In Aimpoint Landings
- Short Field and Emergency Landing Site (ELS) Speedbrake Settings
- High HAC Wind Conditions
- Multiple Failure Combinations
- 3 Sigma Head and Tail Wind Profiles

Supplementary objectives are added to reflect recent changes to landing tasks. When new objectives are defined, they are coordinated with Flight Directors, the Orbiter Project Office, and landing and rollout engineer specialists to ensure objectives are correctly scoped to the Shuttle Program requirements. Once defined, the training objectives are provided to the USA Approach and Landing Flight Design engineers for training matrix development. The most recent supplementary objective addition involved pilot runway familiarization and brake procedure modification associated with the new temporary runway implemented at Edwards Air Force Base in May 2008. The runway visual scene was implemented at VMS two years prior, allowing the Shuttle Program to prepare for the potential operational effects associated with the shorter and narrower runway. Many objectives are standardized training; however, new capabilities are developed as required.

B. Training Matrix Development

Based on the objectives determined for the training session, USA engineers begin the process of developing the training matrix. The training matrix contains all information necessary to properly configure the simulation. An agreement between the Astronaut Office, the VMS, and USA to standardize the format of the matrix allowed the development of Visual Basic for Applications (VBA) tools for each step of the training matrix lifecycle: production of the matrix, conversion of the matrix content into script files to run on the VMS, pre-simulation checkout of the VMS, and post-simulation analysis reports that are provided to each pilot.

There are two major components defined in the training matrix for each training run: OTW visual definition and vehicle performance. The OTW visual definition contains all visual aspects of the simulation including weather (ceiling and visibility), lighting (day or night), and landing site location. Performance characteristics include mass properties customized to each Shuttle mission configuration, speedbrake setting, aimpoint configuration, wind profile, and landing performance predictions. Once the training objectives are agreed upon, USA engineers generate landing performance predictions for each case on the matrix. These predictions are generated by an in-house, three degree of freedom simulator, which uses the same software that provides real-time landing predictions to the Mission Control Center for an actual Shuttle landing.

After generating landing performance data for each flight specific matrix, USA Flight Design engineers review the data to ensure no flight rule limits are violated. These limits ensure safety of the crew and vehicle by protecting against both low and high energy landing situations. If flight rule limits are violated, the analyst evaluates the use of established energy management techniques for the Space Shuttle, including modifying speedbrake and aimpoint settings. If these techniques do not bring the case within flight rule limits, the wind profile for the delinquent case must be modified to alleviate the violation. When all the performance data have been generated, the training matrix is populated with the data and sent out to the Shuttle landing and rollout engineering community for review.

C. Engineering Study Test Plan Development

Engineering studies typically result from changes to math models, flight software and/or flight rules that require pilot-in-the-loop testing. Evaluating these changes at the VMS is an integral part of the engineering process, as it allows the engineers to assess the integrated performance of the flight software and math models coupled with the pilot-in-the-loop interface. Prior to the Ames session, testing and evaluation is performed using engineering simulators to examine the proposed changes. This often involves months, if not years, of simulation work and trade studies by engineers from Boeing, USA, and NASA Engineering. While not all changes in the subsonic region are tested in the VMS, most changes are not finalized until rigorous testing and analysis has been completed at the VMS facility. This is typically true for those changes that affect the piloted performance of the Orbiter. The overall configuration of the test matrix that is brought to the VMS is a subset of the test matrix used for the initial design of the change. Included in the VMS specific matrix are the test cases that bound the expected vehicle response and performance. The inherent flexibility of the Ames VMS simulator and support systems allows engineers to test multiple configurations of the proposed changes.

D. Pre-Simulation Preparations at the VMS

Preparations at the VMS require the checkout of the Shuttle ICab and the simulation software. The ICab hardware preparations include checking all the buttons, switches and controllers as well as calibration and alignment of the HUDs. The last step in ICab preparation is motion tuning. Sample training runs requiring various motion profiles are flown by an in-house VMS pilot, and the motion gains are adjusted to maximize the motion envelope while maintaining cue fidelity.

Simulation software changes for each training and engineering session are defined either by change requests or a test plan. Typical software changes include implementing a new wind profile, adding a new landing database, correcting a parameter, or a complex math model change such as implementing a new tire model. Periodic software audits also identify software changes required. Constant review of simulation results has led to systematic improvements to the simulation.

Once all of the change requests have been implemented, the Shuttle math model is checked by running a series of static and dynamic checks. The static and dynamic check results are then compared to post simulation checks from the previous session to ensure that the vehicle response dynamics have not changed. Once the in-house verification is complete, responsibility for the final verification is completed by Boeing Entry Integrated Guidance Navigation and Control (GN&C). Boeing Entry Integrated GN&C, in conjunction with JSC Engineering and VMS engineers, verify the VMS Shuttle math models' response by conducting various checkout tests. For sessions that only involve crew training, the following checks are performed:

- Hardware response checks of the flight controls and antiskid box.
- Aeroslices which confirm the aero and atmosphere models.
- Trajectory comparisons to verify vehicle specific performance.
- Gain and phase margin checks to confirm the validity of the flight control system models by opening various control loops and checking the phase and gain margins across those loops.
- Dynamics checks to confirm that the end-to-end system response to step and doublet inputs are within specifications.
- Sim-to-sim comparisons of a specific set of trajectories from the VMS and both the Shuttle Descent Analysis Program (SDAP) and Shuttle Engineering Simulator (SES) to evaluate overall integrated GN&C performance. SDAP and the SES are six degree of freedom simulators used by Boeing and NASA Engineering to support engineering studies and real-time mission analysis.

If the session includes an engineering study, additional checks of the math models pertaining to that study are required. Engineering studies often include changes to existing math models or new math models that will require implementation by the VMS engineers. These models are usually developed previously in the SDAP and the SES. Verification of the engineering study math models may include:

- Review of the VMS math model code.
- Study specific check cases that are developed to exercise specific math models and are run and compared in the VMS, SDAP, and SES. These check cases are used to verify proper implementation of math models, as well as to confirm that the changes do not introduce unwanted effects to the integrated simulation.

Training matrix preparation begins when it is delivered to the VMS two weeks prior to the simulation session. The training matrix typically consists of four to six missions with 25 to 30 training runs for each mission. Each mission has a unique set of mass properties and a specific set of landing sites. For example, a mission to the

International Space Station will have a different set of emergency landing sites than a mission to service the Hubble Space Telescope due to launch inclination.

A script file is generated for each training run from the training matrix, which defines the vehicle and environment configuration. Each training run is then checked for visual scene and performance correctness. The visual scene checkout is labor-intensive and time-consuming. Each runway must be checked under night, day, and dusk conditions. Each lighting condition requires different runway and navigation aid lighting intensities. Currently, the VMS visual database for Shuttle training consists of 21 different landing sites:

- Atlantic City International Airport
- Banjul International, Gambia
- Ben Guerir, Morocco
- Bermuda International
- Cherry Point Marine Corps Air Station
- Dover Air Force Base
- Edwards Air Force Base
- Elizabeth City Coast Guard Air Station
- Francis S. Gabreski Airport
- Halifax International, Canada
- Istres Air Base, France
- Kennedy Space Center
- Moron Air Base, Spain
- Myrtle Beach International Airport
- Oceana Naval Air Station
- Otis Air National Guard Base
- Portsmouth International Airport at Pease
- Wallops Flight Facility
- White Sands Space Harbor
- Wilmington International Airport
- Zaragoza Air Base, Spain

Performance checkout consists of verifying that the mass properties, implemented failures, the vehicle trim position, and landing predictions are met. The performance checkout is performed by using the autopilot and comparing the data to predictions provided on the training matrix. The key parameters that are checked are the normalized touchdown speed, touchdown distance, and the speedbrake settings. No training or engineering studies will begin until all verification steps are completed.

VII. Training/Engineering Operational Phase

The operational phase is essentially the same for training and engineering studies. The only difference is that during engineering studies, debriefs are held at the end of each day to review the recent data and pilot observations. The vehicle and pilot performance are assessed and compared against engineering predictions that were made during the initial analysis development using SDAP and SES. Based on the assessment of the overall progress of the study, recommendations for possible changes and modifications to the engineering matrix, math models, or piloting tasks are made. Milestones and goals can also be reprioritized based on the current assessment of the study.

The first day of the scheduled operational session is reserved for checkout by the Instructor Pilot. The Instructor Pilot is an Astronaut who has been assigned to run the training session. The Instructor Pilot flies each case on the training matrix prepared for the crew scheduled for the next Shuttle mission to verify the integrated configuration of the simulator visuals, motion cues, and vehicle performance. Based on the comments from the Instructor Pilot, the weather, lighting, or other run setup parameters may be adjusted accordingly. The flexibility of the VMS architecture allows for these changes to be rapidly incorporated.

A. Pilot Briefing

A briefing is held prior to a single pilot or crew's training session. This is an opportunity to provide a refresher on the characteristics, handling qualities, landing systems hardware operational descriptions, runways, flight rules, displays, and landing task requirements associated with Shuttle landings. In addition, the briefing provides an opportunity to define training or engineering session objectives, outline VMS safety and operational protocols, and ask questions or get feedback for the training or engineering session the pilot is about to start. A briefing document is updated each session to provide up-to-date information maintained by the Shuttle Program. This brief is authored by the Astronaut Office, JSC Engineering, JSC Training, Boeing, and USA Flight Design.

B. Pilot Training

Pilot training consists of a Commander (in the left seat) and Pilot (in the right seat) flying runs from their training matrix within a four hour session. The Commander and Pilot alternate flying the runs. During the simulation, the flight crew is free to ask questions and make comments. The Instructor Pilot and a team of engineers and trainers from NASA, Boeing, and USA are present to answer questions real-time. The ability to answer the

flight crew’s questions instantly is a valuable training aid because it eliminates any confusion the flight crew may have and reinforces training objectives.

Two types of reports are provided to the pilots after each session. The first report provides feedback on consistency for four nominal runs with the same approach profile co-plotted. The format is similar to the feedback flight crews are given during STA training sessions. The graphs provide altitude, altitude rate, hand controller inputs, and corresponding elevon response plotted against distance to the runway threshold. These graphs allow the pilot to evaluate how the runs were flown compared to the 1.5 degree inner glide slope approach, review applied control inputs, determine if desired landing parameters were achieved, and evaluate the consistency of the four co-plotted runs.

A second report lists the setup conditions of each run completed and the resulting threshold crossing height, altitude rate at touchdown, distance delta from the glide slope at 3000 ft altitude, touchdown speed, lateral distance at touchdown, and the maximum lateral distance observed during the rollout. In addition, deltas from the targeted threshold crossing height and touchdown speed are provided to allow the pilot to note if their approaches are “high” or “low” and “fast” or “slow.” Averages and standard deviations of the nominal landings are also provided. Figure 10 represents the data provided to a pilot after their session. Also included are results for the entire Astronaut Pilot Corps with mission experience, so that the pilot can compare their averages and deviations with experienced pilots.

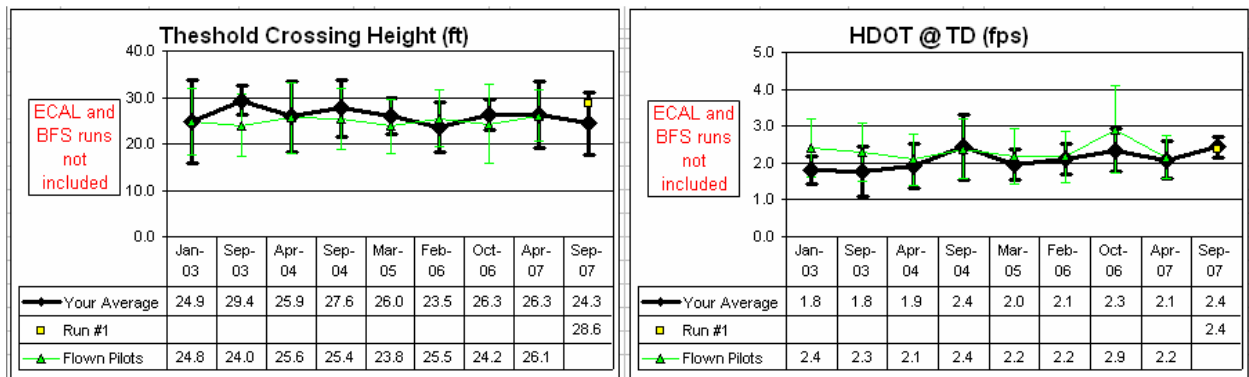

Figure 10. Sample Shuttle Pilot VMS Report

The two reports are used by the Astronaut pilots to evaluate their own technique and performance, and the reports are not used to evaluate pilots compared to each other. These data also allow each pilot to evaluate their first simulation run. The first run is particularly significant as it is the one run most like the actual Orbiter landing. Like a real landing, the Commander will not have had the opportunity for practice approaches to check out or evaluate the landing conditions prior to touchdown. The Commander’s landing skills need to be capable of handling whatever conditions exist on their only attempt. Commanders and their Pilots understand that subsequent personal landing performance may deviate from an actual Orbiter landing as they “learn” the subtleties of the simulator.

Because the Ames VMS architecture is flexible, training sessions at the VMS can be modified during a session to provide assigned Shuttle Commanders and Pilots the desired landing cases they wish to see prior to their mission. In addition, a Commander’s previous mission landing can be replicated with the observed recorded winds, actual mass properties, and weather conditions observed on the day of their landing. This allows the Commanders to re-fly their approach and landing. Commanders provide appropriate feedback that improves the fidelity of the VMS simulation. Providing these landing “emulations” of a Commander’s actual landing typically reinforces the importance of the Ames VMS simulation to the Shuttle Program. Flown Commanders state that the Ames VMS is the valuable asset as it provides the ability to duplicate the real world motion cues that occur during landing and rollout.⁹

An additional benefit of the Ames VMS training session is to provide flight directors and engineers with a chance to view training runs. Though not a requirement, these training sessions allow the landing support team to understand the nuances associated with landing an Orbiter. The experience of observing a VMS training session gives them more insight and understanding of the landing task from the flight crew’s perspective.

VIII. Post Simulation Phase

At the conclusion of a simulation session, all data collected are sent to the Astronaut Office and Boeing for analysis within one week of the session end date. These data consist of 941 time history data points, 782 static

variables data points, and video of every training run. Examples of the time history data include the vehicle states, controller positions, and wind data at 0.040 second intervals of the training run. Examples of the static data include the threshold crossing height, touchdown position, and altitude rate at touchdown. Currently, a two week training session will generate more than 400 data runs.

A. Post-Simulation Wrap-up

At the conclusion of the simulation, the VMS simulation engineer performs post-simulation static and dynamic checks of the simulation math model. The post-simulation dynamic checks are compared to the pre-simulation static dynamic checks to ensure that the math model response has not changed over the course of the simulation session. When the checks are completed, the simulation code is archived, a post-simulation report is written, and the simulation user's guide is updated if necessary.

The post-simulation report documents all aspects of the simulation development and operation. This document provides a historical record of the simulation development and is a good reference when investigating the reasons for past implementations and methods. The simulation user's guide is a set of directions that describes how to operate the simulation. The user's guide is updated only when the operation of the simulation changes.

VMS management requests a post-simulation briefing from the Astronaut Office. The post-simulation briefing is an opportunity for the VMS users to discuss what went well during the simulation and what could be improved. The post-simulation briefing provides valuable feedback that is used to improve the simulation for the next Shuttle training session.

B. Data Reduction at JSC

For training sessions, a copy of the data recorded during the session is kept for reference and minimal post processing is done. Pilot reports given to the pilots after their training session are verified to be correct. These data are then saved to a database to ensure "trending" data for the next session are correct. JSC Engineering also receives the data.

After an engineering session, Boeing works with JSC Engineering to analyze and characterize the data in preparation for post-session debriefings at various Shuttle Program technical and operational boards and panels. Results from the Ames sessions play a major role in characterizing the final implementation of Shuttle math models, flight software changes, and flight rules.

IX. Engineering Studies

The first engineering study simulation at the VMS occurred in April 1980 to investigate a PIO the Space Shuttle encountered during approach and landing tests (ALT). Before the orbital flights of the Space Shuttle, five ALT flights were made to evaluate the low-speed characteristics during the approach and landing. The Orbiter was released from a modified Boeing 747 at 20,000 ft and the flight regime to touchdown was investigated. The fifth landing was on the 15,000 ft concrete runway at Edwards and PIOs in both the pitch and roll axes were experienced near touchdown. In 1978, after the ALT experience, a simulation program was conducted to study the cause and significance of the PIO characteristics using the Ames Flight Simulator for Advanced Aircraft (FSAA) motion-based simulation and the U.S. Air Force/Calspan Total In-Flight Simulator (TIFS).²

The TIFS was able to reproduce the PIO tendency, though the FSAA with limited motion and visual cues produced very little PIO tendency compared to the TIFS. When the VMS came online, another series of simulations were made using the VMS and the TIFS. The VMS had sufficient vertical motion to provide good vertical motion cues but it had the same visual display that was used on the FSAA. The PIO tendency of the VMS was much better than the FSAA. Since the VMS proved that it could produce the necessary vertical cues, further simulations were conducted on the VMS to investigate other control system modifications to improve the low-speed handling qualities.

Over the last 30 years, more than 80 Shuttle engineering studies have been conducted at the VMS with more than 20 flight rules affected as a result. Flight rules are the defined set of requirements, procedures, and guidelines that impact the operational aspects of any Space Shuttle mission. Flight rules can be generic, applied to every flight and every vehicle configuration, or specific to an individual flight. Flight rules are designed to allow the flight crew, mission controllers, and mission designers to operate the vehicle and all systems safely within the limits and tolerances of the Orbiter while still successfully achieving all mission goals. These rules have been thoroughly researched, tested, evaluated, and vetted in the operational world to ensure that correct decisions are made should the Orbiter experience an off-nominal scenario.

The most recent engineering study will be discussed in more detail. The majority of engineering studies can be grouped in the following categories:

- Autoland studies – There were nine engineering studies related to autoland design, evaluation, HUD symbology development, and detailed test objective (DTO) support. A DTO is an in-flight maneuver used to gather aero data. These studies were conducted between April 1980 and September 1992.
- Speedbrake studies – There were seven speedbrake related studies between March 1984 and March 2001. Five dealt with evaluating the control logic for the automatic speedbrake and two dealt with manual emergency landing site speedbrake settings.
- Braking studies – There were five braking studies conducted between August 1988 and September 2007. These studies looked at braking force gains, brake energy at TAL sites, and braking procedures.
- Handling quality studies – There were eight handling quality studies between March 1985 and January 1997. These studies evaluated handling qualities during accelerometer assembly hardovers, rolling out on the Edwards lakebed, subsonic DTO, drag chute deploy, new tire evaluation, low tire pressure, tire failure, differential braking, and strong head and tail surface winds.
- Nose wheel steering studies – There were five nose wheel steering engineering studies between August 1985 and January 2004. These studies evaluated handling characteristics on dry and wet surfaces, compared nose wheel steering to nose wheel caster, investigated modifications to nose wheel steering actuators, and conducted a nose wheel steering recertification.
- Crosswind limit studies – There were nine crosswind limit studies between August 1987 and August 2000. There were four studies that evaluated the crosswind limits for RTLs, two with wind gusts, one with gusts and turbulence, and one specific to the STS-30 mission.
- Drag chute studies – There were ten drag chute related studies conducted between March 1987 and June 1997. These studies evaluated the size, design, performance, limits, and deployment procedures of the chute.
- Tire studies – There were seven tire related engineering studies performed at the VMS between March 1985 and September 2003. These studies evaluated handling qualities with new tires, failed tires, procedures for blown or low pressure tires, tire failure evaluation on lakebed and concrete runways, tire wear reduction techniques, tire wear caused by the KSC runway surface, and tire wear due to load persistence.
- Auxiliary Power Unit (APU) studies – There were five APU studies performed between August 1998 and March 2000. Three APUs provide hydraulic power to the flight control surfaces, braking, and nose wheel steering. These studies evaluated procedures and techniques with an APU failure such as manually setting the speedbrake, preferred landing site with APU failure (lakebed versus concrete runway), increased hydraulic flow rate, and priority rate limiting.
- Derotation studies – There were seven derotation related studies between October 1990 and April 1999. Derotation occurs when the Shuttle pitches forward after main gear touchdown and its nose gear touches the ground. These studies included derotation HUD symbology, effects of different derotation techniques, procedures for landing gear loads, and derotation loads at different airspeeds.

Example: Crew Evaluation of Modified Braking Procedure

The Shuttle Program has performed several braking studies since the antiskid unit was integrated into the simulation in 1994 providing the same braking system response as seen on the Orbiter. The most recent engineering braking study was the crew evaluation of modified braking procedures.

Edwards Air Force Base closed the concrete runway (EDW 04/22) for repairs in May 2008. To provide uninterrupted landing capabilities, a temporary runway was constructed. All operations transitioned to the temporary runway for the duration of repair work on the main runway.¹⁰ The concrete main runway is 15,000 ft long and the temporary runway is 12,000 ft long. Due to the shorter length of the temporary runway, operational techniques to reduce brake energy needed to be evaluated. One option to reduce the brake energy was to delay initiation of the maximum braking profile from 5,000 ft to 4,000 ft remaining to the end of the runway. This option was selected for further study, including pilot evaluation at the VMS, and examined the following four braking scenarios:

1. Initiate braking at 5,000 ft remaining on runway using the drag chute.
2. Initiate braking at 5,000 ft remaining on runway without drag chute.
3. Initiate braking at 4,000 ft remaining on runway using the drag chute.
4. Initiate braking at 4,000 ft remaining on runway without drag chute.

The crew evaluation of modified braking procedures was conducted at the VMS in October 2007 with 130 data runs obtained using the modified braking procedures. Figure 11 displays the total brake energy used to come to a stop as a function of runway remaining when braking was initiated. The brake energy was computed each time step by the VMS software and integrated until wheel stop to calculate the total brake energy.

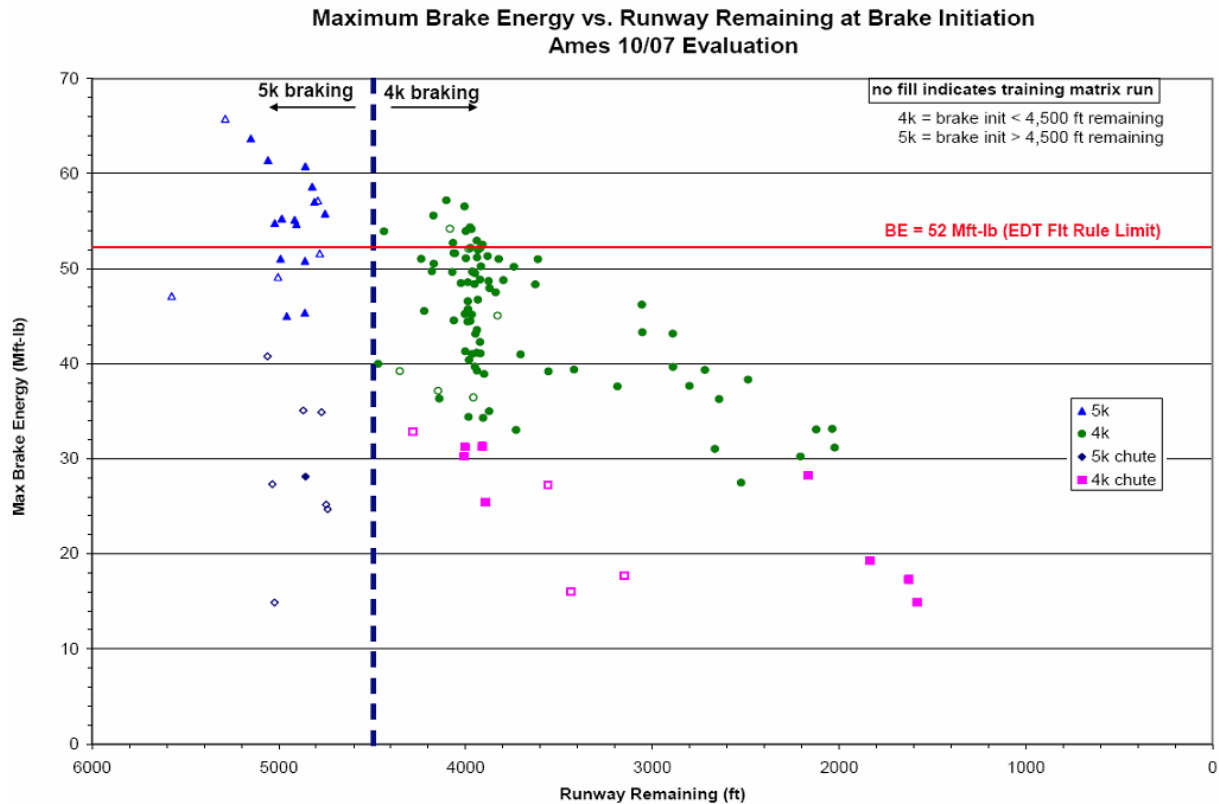

Figure 11: Brake Energy Dispersion

Braking with 4,000 ft runway remaining with a drag chute did not exceed the maximum allowable brake energy. The braking cases without a chute did at times exceed the allowable braking energy with braking initiated at both 4,000 and 5,000 ft of runway remaining. The study found that the brake energy was reduced by at least 14 Mft-lb when using the modified braking procedure.¹¹ The results of the crew evaluation of modified braking procedures engineering study lead to a flight rule change that modified braking procedures for a heavy weight Orbiter landing on the Edwards temporary runway.

X. Conclusion

Landing and rollout training on the VMS has been an integral part of the Shuttle Program over the past 28 years. Every pilot who has flown the Shuttle has trained on the VMS and more than 65,000 landing and rollout training and engineering runs have been completed. It is the only time, other than on the actual Orbiter, a Shuttle pilot can “feel” what it is like to land the vehicle. Experienced Shuttle Commanders have stated that the Ames VMS is the most accurate representation of an actual Shuttle landing from 50 feet through rollout.

The VMS has been used to conduct more than 80 engineering studies that have led to more than twenty Shuttle flight rule changes. The most recent engineering braking study was the crew evaluation of modified braking procedures which resulted in a flight rule change to the braking procedures on the Edwards Air Force Base temporary runway.

The continuous, long-term review of the VMS simulation results has led to systematic improvements to the Shuttle landing and rollout simulation. These improvements have led to better training resulting in improved safety and operation of the Orbiter.

References

- ¹ “Space Shuttle Computer Systems and Software Requirements Book 2 Allocation of Simulation Functions,” NSTS 07700 VOL XVIII BK 2 Revision B, June 14, 1993.
- ² Boeing, “Landing Mishaps Due to Failures of Guidance, Navigation and Control Functions/Landing Aids or Adverse Landing Conditions,” ORBI 211, Houston, TX, January 2005
- ³ Powers, B. G., “Space Shuttle Longitudinal Landing Flying Qualities,” *Journal of Guidance, Control and Dynamics*, Vol. 9, No. 5, 1986, pp. 566, 572.
- ⁴ Mission Operations Directorate Flight Design and Dynamics Division Ascent/Descent Dynamics Branch. “Flight Procedures Handbook – Approach, Landing and Rollout,” NASA JSC-23266, May 2005.
- ⁵ Aponso, B. L., Tran, D. T., and Schroeder, J. A., “Rotorcraft Research at the NASA Vertical Motion Simulator,” AHS Conference, Montreal, Canada, 2008.
- ⁶ Dafler, Wes “Ames Math Model Audit and Change Summary, Dec 2003 – Jan 2004 Engineering Study,” Boeing Space Exploration, Houston, TX, Feb. 2, 2004.
- ⁷ Mission Operations Directorate Flight Design and Dynamics Division Ascent/Descent Dynamics Branch. “Flight Procedures Handbook – Approach, Landing and Rollout,” NASA JSC-23266, May 2005.
- ⁸ Flight Crew Operations Directorate Astronaut Office, “Astronaut Continuation Training Minimum Currency Requirements,” NASA JSC CB-QMR-003, March 2003.
- ⁹ Casper, J., “Pilot Report: Ames Vertical Motion Simulator Orbiter Landing and Rollout Evaluation – 1988,” Astronaut Office, Johnson Space Center, Houston, TX, October, 1988.
- ¹⁰ Mader, B., “Edwards Temporary Runway Alternate Braking Procedure Evaluation Test Plan,” USA Flight Descent Design, Houston, TX, September 2007.
- ¹¹ Jones, R. S., “EDW Temporary Runway Operations SR4113A JSC-MV (Replacement Charts),” JSC Mission Operations Directorate, Flight Director Office, April 17, 2008.
- ¹¹ Space Flight Operations Contract, “Shuttle Crew Operations Manual,” USA007587, Houston, TX, October 15, 2004.