

NASA/TM—2002-211304



Status of Brayton Cycle Power Conversion Development at NASA GRC

Lee S. Mason, Richard K. Shaltens, James L. Dolce, and Robert L. Cataldo
Glenn Research Center, Cleveland, Ohio

January 2002

The NASA STI Program Office . . . in Profile

Since its founding, NASA has been dedicated to the advancement of aeronautics and space science. The NASA Scientific and Technical Information (STI) Program Office plays a key part in helping NASA maintain this important role.

The NASA STI Program Office is operated by Langley Research Center, the Lead Center for NASA's scientific and technical information. The NASA STI Program Office provides access to the NASA STI Database, the largest collection of aeronautical and space science STI in the world. The Program Office is also NASA's institutional mechanism for disseminating the results of its research and development activities. These results are published by NASA in the NASA STI Report Series, which includes the following report types:

- **TECHNICAL PUBLICATION.** Reports of completed research or a major significant phase of research that present the results of NASA programs and include extensive data or theoretical analysis. Includes compilations of significant scientific and technical data and information deemed to be of continuing reference value. NASA's counterpart of peer-reviewed formal professional papers but has less stringent limitations on manuscript length and extent of graphic presentations.
- **TECHNICAL MEMORANDUM.** Scientific and technical findings that are preliminary or of specialized interest, e.g., quick release reports, working papers, and bibliographies that contain minimal annotation. Does not contain extensive analysis.
- **CONTRACTOR REPORT.** Scientific and technical findings by NASA-sponsored contractors and grantees.

- **CONFERENCE PUBLICATION.** Collected papers from scientific and technical conferences, symposia, seminars, or other meetings sponsored or cosponsored by NASA.
- **SPECIAL PUBLICATION.** Scientific, technical, or historical information from NASA programs, projects, and missions, often concerned with subjects having substantial public interest.
- **TECHNICAL TRANSLATION.** English-language translations of foreign scientific and technical material pertinent to NASA's mission.

Specialized services that complement the STI Program Office's diverse offerings include creating custom thesauri, building customized data bases, organizing and publishing research results . . . even providing videos.

For more information about the NASA STI Program Office, see the following:

- Access the NASA STI Program Home Page at <http://www.sti.nasa.gov>
- E-mail your question via the Internet to help@sti.nasa.gov
- Fax your question to the NASA Access Help Desk at 301-621-0134
- Telephone the NASA Access Help Desk at 301-621-0390
- Write to:
NASA Access Help Desk
NASA Center for Aerospace Information
7121 Standard Drive
Hanover, MD 21076

NASA/TM—2002-211304



Status of Brayton Cycle Power Conversion Development at NASA GRC

Lee S. Mason, Richard K. Shaltens, James L. Dolce, and Robert L. Cataldo
Glenn Research Center, Cleveland, Ohio

Prepared for the
Space Technology and Applications International Forum (STAIF-2002)
sponsored by the American Institute of Aeronautics and Astronautics
Albuquerque, New Mexico, February 3–7, 2002

National Aeronautics and
Space Administration

Glenn Research Center

This report contains preliminary findings, subject to revision as analysis proceeds.

Available from

NASA Center for Aerospace Information
7121 Standard Drive
Hanover, MD 21076

National Technical Information Service
5285 Port Royal Road
Springfield, VA 22100

Available electronically at <http://gltrs.grc.nasa.gov/GLTRS>

Status of Brayton Cycle Power Conversion Development at NASA GRC

Lee S. Mason,¹ Richard K. Shaltens,² James L. Dolce,³ and Robert L. Cataldo⁴
National Aeronautics and Space Administration
Glenn Research Center
Cleveland, Ohio 44135

Abstract. The NASA Glenn Research Center is pursuing the development of Brayton cycle power conversion for various NASA initiatives. Brayton cycle power systems offer numerous advantages for space power generation including high efficiency, long life, high maturity, and broad scalability. Candidate mission applications include surface rovers and bases, advanced propulsion vehicles, and earth orbiting satellites. A key advantage is the ability for Brayton converters to span the wide range of power demands of future missions from several kilowatts to multi-megawatts using either solar, isotope, or reactor heat sources. Brayton technology has been under development by NASA since the early 1960's resulting in engine prototypes in the 2 to 15 kW-class that have demonstrated conversion efficiency of almost 30% and cumulative operation in excess of 40,000 hours. Present efforts at GRC are focusing on a 2 kW testbed as a proving ground for future component advances and operational strategies, and a 25 kW engine design as a modular building block for 100 kW-class electric propulsion and Mars surface power applications.

INTRODUCTION

The NASA Office of Space Science (Code S) In-Space Propulsion Program (formerly the Code R Advanced Space Transportation Program) is sponsoring the development of Brayton cycle power conversion technology for future fission propulsion applications. Brayton systems offer a low mass, highly scalable (kilowatts to megawatts) power generation option to support various propulsion architectures. While in-space propulsion provides the major focus, other potential users include NASA's Human Exploration and the Development of Space (HEDS) Enterprise, the Department of Defense, and the commercial satellite industry.

Brayton power converters can be combined with various heat sources including solar receivers, radioisotope heat source modules, or nuclear reactors. In all cases, heat energy is supplied to the Brayton unit where a fraction of the heat is converted into electricity while the remainder is rejected as waste heat. A Brayton converter consists of a turbine, compressor, and alternator in a sealed housing (called a turbo-alternator) and separate heat exchangers for the heat source and the waste heat rejection. An inert gas, typically a mixture of helium and xenon, is used as the cycle working fluid.

A schematic diagram of a closed Brayton cycle conversion system is shown in Figure 1. The heated fluid from the heat source heat exchanger is expanded through the turbine, passed through a gas cooler where waste heat is transferred to a liquid coolant, and pressurized in the compressor before being re-heated by the heat source. A recuperator heat exchanger between the turbine discharge and heat source inlet is often used to improve cycle efficiency. Waste heat transferred to the liquid coolant is rejected via radiator panels to space. The rotary alternator produces three phase, alternating current (AC). A power management and distribution (PMAD) unit provides electrical control for the Brayton, converts the electrical output to direct current (DC) (if required) and distributes the power to the various spacecraft loads.

¹Phone: 216-977-7106, Email: Lee.Mason@grc.nasa.gov

²Phone: 216-433-6138, Email: Richard.Shaltens@grc.nasa.gov

³Phone: 216-433-8052, Email: James.Dolce@grc.nasa.gov

⁴Phone: 216-977-7082, Email: Robert.Cataldo@grc.nasa.gov

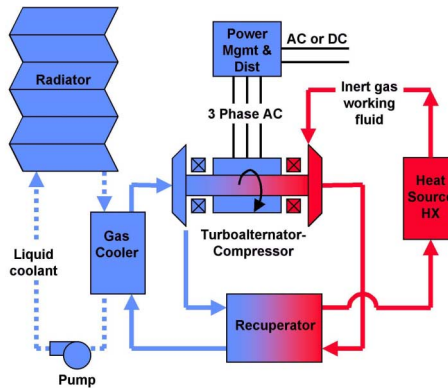

FIGURE 1. Schematic Diagram of Closed Brayton Cycle.

BENEFITS OF BRAYTON TECHNOLOGY

Brayton technology offers numerous benefits for future NASA missions as described in the following sections:

High efficiency—Radioisotope Thermoelectric Generators (RTGs) used on many space probes provide thermal-to-electric efficiencies of about 6 to 7%. Recent testing of a 2 kW Solar Dynamic (SD) power system demonstrated Brayton conversion efficiencies of over 29% using 1970's component technology (Shaltens, 1999). Efficiency improvements can be realized with newer technology and properly selected design parameters including the cycle temperature ratio and compressor pressure ratio. The high efficiency directly translates into reduced heat source and radiator thermal power levels. These reductions result in mass savings for the heat source and radiator and improved launch vehicle packaging.

Attractive electrical output characteristics—Brayton conversion units provide constant power output over the mission life with little or no degradation. The potential for AC power transmission with Brayton could result in considerable conductor mass savings as compared to DC transmission. The rotary alternator of the Brayton unit can be custom configured to provide very high voltage from the windings, perhaps as high as 10,000 Vrms. The high source voltage decreases resistive losses to improve the overall efficiency, reduces the current rating of the transmission cable to lower mass, and opens the possibility for direct drive to high voltage loads such as electric thrusters. The relatively high speed of the alternator rotor (30 to 60 krpm) also contributes to a high frequency output (800 to 1600 Hz) which helps to minimize the transformer mass when converting to different voltage levels.

Scalability to high power—While many static power conversion technologies scale linearly with power level, the turbo-machinery and heat exchangers that comprise Brayton systems do not. High power machines can be very compact and lightweight. Figure 2 presents the improvement in specific mass (kg/kW) with increasing power level for three different space Brayton turbo-alternator designs. The 35 kW turbo-alternator design from the Space Station Freedom (SSF), Solar Dynamic Power Module (SDPM) offers nearly a 3X reduction in specific mass relative to the 2 kW mini-Brayton Rotating Unit (mini-BRU) unit and a 1.5X reduction compared to the 15 kW Brayton Rotating Unit (BRU). This favorable scaling characteristic makes Brayton technology very attractive for high power applications.

Ease of manufacturing—Brayton technology is prevalent in many high power terrestrial applications. Gas turbine electric power plants can provide 100's of megawatts and are in widespread use in North America and Europe. Aircraft auxiliary power units (APUs), that provide 100's of kilowatts, are found in most of today's larger commercial jets. Gas turbine systems are also utilized in large marine propulsion applications. This infrastructure provides a foundation for manufacturing of future space power systems, particularly the turbo-machinery components and heat exchangers. The potential for automated production of Brayton components is contrary to the tedious "hands-on" assembly processes that are characteristic of solar photovoltaic arrays. The ease of manufacturing contributes to both cost and schedule benefits.

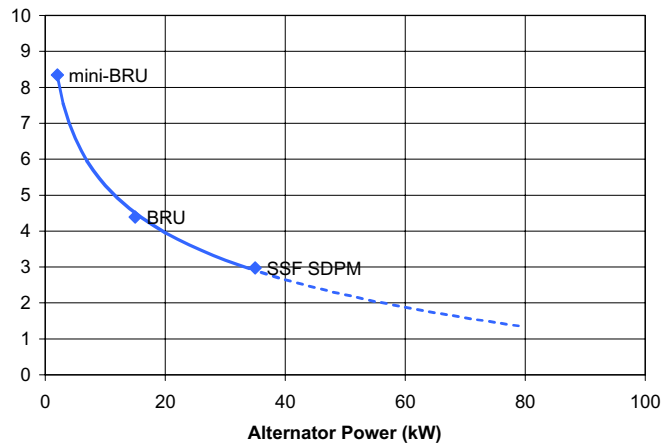

FIGURE 2. Turbo-Alternator Mass Scaling.

High reliability, long life and radiation tolerance—Brayton's potential for high reliability is corroborated by the many thousands of long-operating aircraft APUs. Long life for space Brayton conversion is made possible through the use of non-contacting gas foil bearings, hermetic sealing of the gas circuit preventing working fluid loss, redundant electronic components, and ultraviolet/atomic oxygen protective coatings on all optical surfaces. Radiation degradation is reduced relative to solar photovoltaic arrays since semi-conducting materials are not used on the large exposed surfaces. The constant power output characteristic of Brayton converters assures a stable and reliable power source for the entire mission duration.

POTENTIAL MISSIONS

There are several NASA mission classes for which Brayton cycle power conversion is advantageous including: 1) rovers and robotic science, 2) surface outposts and bases, 3) advanced propulsion vehicles, and 4) earth orbiting satellites.

Rovers and Robotic Science—Robotic science missions will serve as a precursor to human missions for site surveying, engineering data gathering, and technology demonstration. These missions will include orbiters for surface mapping, landers for localized science, and rovers for regional reconnaissance. Current solar photovoltaic technologies limit surface mission duration to about 90 to 120 days. Advanced radioisotope power systems are being developed that will provide constant day/night power in the multi-hundred watt class for 2 to 5 years and beyond. As the science objectives are expanded, power requirements are expected to increase. Candidate applications include science rovers for Mars polar missions to search for evidence of water, remote science landers with deep drilling capabilities, sample return missions, and ultimately, rovers for piloted surface transportation. Power levels are projected in the 1 to 10 kW range.

Surface Outposts and Bases—The outpost will be the initial human emplacement and will include landers, habitats, and resource pilot plants. Nuclear power systems which are unaffected by the day/night cycle and resistant to environmental degradation are strongly favored. Two primary options exist for power generation: 1) smaller, dedicated systems for each element, or 2) a centralized reactor power system that serves multiple elements. The reactor power system is favored to minimize mass and allow for outpost evolution. Aggregate power requirements for the surface outpost are in the 10 to 50 kW range. Follow-on surface bases will establish a semi-permanent or permanent human presence. These missions will include scientific laboratories, habitats with closed loop life support, and resource production plants. Power levels could grow into the multi-hundred kilowatt range.

Advanced Propulsion Vehicles—Future robotic and human missions will rely heavily on advanced propulsion technologies to improve payload fraction and trip time. Electric propulsion systems can provide large propellant mass savings over chemical systems due to their very high specific impulse, but require considerably more

spacecraft power. Power levels associated with nuclear electric propulsion (NEP) vehicles will range from about 100 kW for smaller outer planet science missions to multi-megawatts for large Mars human/cargo missions. Nuclear Thermal Rocket (NTR) technology also offers significant performance advantages over chemical propulsion systems due to the combination of high specific impulse and high thrust. The benefits are enhanced through a bi-modal configuration that utilizes the same reactor core for both propulsion and electric power generation.

Earth Orbiting Satellites—As civil, military, and commercial satellites grow in power level, solar Brayton technology provides a viable alternative to excessively large photovoltaic arrays. Power levels for low earth orbit (LEO) earth observation satellites are projected in the 5 to 10 kW range. Military missions employing space-based radar or space-based laser technologies are expected to range from several kilowatts to over 100 kilowatts, and may require the power system to operate in a pulsed-power mode. Commercial communications satellites in geosynchronous orbit (GEO) in the 15 to 20 kW level are already in use and projections show power levels increasing to more than 50 kW.

BRAYTON HISTORY

Space Brayton technology was introduced in the late 1960's under the Brayton Rotating Unit (BRU) development program. The objective was to design, build, and test a 10.5 kW Brayton conversion system that could be used with either a solar heat receiver or isotope heat source (Davis, 1972). Four separate BRU turbo-alternator units were fabricated and tested, compiling over 40,000 hours of operation. The overall power conversion system included a Brayton Heat Exchanger Unit (BHXU) providing a combined recuperator and gas cooler for the BRU. Near the end of the program, one of the turbo-alternators (BRU-F) was modified with foil bearings and a higher capacity cooling system to produce 15 kW. The BRU program was followed closely by the Brayton Isotope Power System (BIPS) program in the mid-1970's. Under BIPS, a 2 kW mini-BRU and recuperator were developed for isotope power applications (McCormick, 1978). The scaled version incorporated advanced foil bearings and internal stator cooling for greater reliability and simplicity. The mini-BRU was successfully tested for 1000 hours during the BIPS program. A scale comparison of the BRU and mini-BRU units is provided in Figure 3. During the 1980's Space Station Freedom (SSF) program, a 35 kW Brayton Solar Dynamic Power Module (SDPM) underwent significant design and component development before the program was cancelled (Staff, 1993). That design formed the basis for the 1990's 2 kW Solar Dynamic Ground Test Demonstration (SD GTD), which utilized the mini-BRU turbo-alternator and recuperator combined with SDPM derived designs for the concentrator, receiver, and radiator. The SD GTD system compiled 800 hours of operation in a thermal-vacuum environment with simulated solar input (Shaltens, 1999). All of the SD GTD components operated as expected with no failures or degradation. A flight version of the 2 kW solar Brayton power system was nearly completed for a 1998 demonstration on the Mir Space Station, but was cancelled due to Shuttle manifest changes.

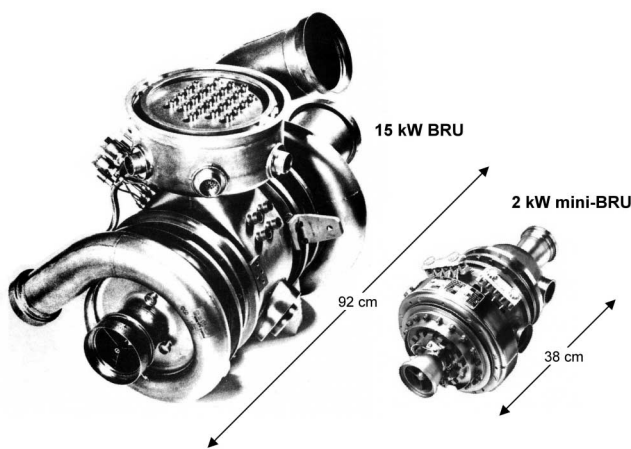

FIGURE 3. Comparison of BRU and Mini-BRU Turbo-Alternators.

CURRENT PROGRAM

The current NASA GRC Brayton power conversion project is pursuing a two-pronged approach to technology development with the primary emphasis on future reactor-powered electric propulsion applications. The first task of the project is the establishment of an in-house Brayton testbed utilizing the 2 kW power conversion unit from the SD GTD project. The second task of the project is the design of a 25 kW-class Brayton converter for a wide-range of potential power and propulsion applications.

The 2 kW Brayton testbed unit, shown in Figure 4, provides an effective tool for refining operations strategies, characterizing subsystem interfaces and evaluating advanced component technologies. A SiC electrical resistance gas heater supplies the heat input for the Brayton converter, in place of the original SD GTD receiver. The heater controller allows thermal simulation of a reactor interface to prove-out startup, transient and shutdown operations. A major focus of this year's activities is the development of a modern breadboard electrical controller. The controller would provide motoring startup capability, speed and voltage control of the Brayton unit, and would interface with potential electric loads. The electrical controller is a key area for technology advancement. Future efforts are planned to address high voltage power transmission (for electric thrusters), multi-Brayton converter operation, digital supervisory control, and autonomous health monitoring. An integrated test of the 2 kW Brayton unit with an ion thruster to demonstrate compatible electrical interfaces has also been proposed. Another area where the 2 kW testbed unit could prove useful is the development of a lightweight Brayton radiator. GRC is pursuing designs for 100 kW-class NEP radiators utilizing advanced composite materials and innovative heat transport techniques. Development of a sub-scale prototype and integration with the 2 kW Brayton unit would demonstrate radiator technology readiness. In the far term, the testbed could serve as a proving ground for advanced high temperature materials. The use of refractory alloys or ceramics for the high temperature elements of the Brayton converter could provide significant system mass and radiator area reductions. As candidate materials are identified, replacement parts could be fabricated for evaluation in the 2 kW unit.

The 25 kW Brayton design studies are meant to provide a starting point for the development of future higher power systems. The 25 kW converter size, as a single unit or in multiples, was chosen to address the widest range of applications from initial Mars surface power plants to robotic NEP to bi-modal NTR. As more focus is given to the mission studies, the nominal converter size may be adjusted. The design effort consists of system studies by GRC and concept development studies by three aerospace contractors: Boeing/Rocketdyne, Pratt & Whitney, and Allison.



FIGURE 4. 2 kW Brayton Testbed Unit at GRC.

The scope of the contractor-led concept studies covers 5 subtasks. Task 1 requires the contractor to develop a conceptual design of a 25 kW converter including state point operating characteristics and physical properties based on existing or near term technology. Tasks 2 through 4 will examine the design and cost impacts of several key performance parameters including higher turbine inlet temperatures (Task 2), higher alternator voltage (Task 3), and increased converter power (Task 4). Task 5 requires the contractors to generate cost estimates and development schedules for the 25 kW converter through engineering demonstration and flight hardware fabrication. The results of these design studies are expected in early '02. Follow-on efforts are anticipated in 2002 and 2003 to generate detailed designs for the fabrication and test of full-scale converter engineering demonstration units.

The GRC analytical studies have examined system configuration options and performance sensitivities. The studies were performed using the Excel-based spreadsheet model, *NUCOPT* (Nuclear Optimization). The model accounts for all the major subsystems: heat source, power conversion, heat rejection, and PMAD. The system studies have focused on a 100 kW NEP application while assuming the use of existing or near term technology. The heat source is based on Marshall Space Flight Center's Safe Affordable Fission Engine (SAFE) heat pipe reactor concept (Houts, 2001) assumed to provide up to 500 kWt with a mass of 489 kg for the reactor, 266 kg for structure and 583 kg for shielding. A 95% efficient heat source heat exchanger provides direct gas heating across the heat pipe condenser sections. The Brayton converters utilize superalloy materials allowing a turbine inlet temperature of 1144K (1600°F). Brayton component efficiencies were assumed as follows: turbine 90%, compressor 80%, recuperator 95%, and alternator 94%. The heat rejection system, consisting of 2-sided radiator panels, heat transport loop, and liquid coolant has an areal density of 6 kg/m² (based on planform area). The 97% efficient PMAD unit accepts 2000 Vrms, 1 kHz alternator output from each of the converters and distributes filtered power to the ion thruster power processing units via a 50 m transmission cable.

The system configuration studies have mainly addressed questions regarding the power conversion architecture. Is a recuperator required? How many converters should be used? What is the impact of carrying a spare converter? Should each converter utilize a dedicated radiator, or should a common radiator be shared among the converters? A reference configuration was developed for the 100 kW NEP application including 3 recuperated-converters, no spares, and dedicated radiators. Including PMAD losses, each converter provides 34.5 kW to meet the 100 kW requirement. Figure 5 shows the system mass and radiator area trade-offs versus reactor thermal power for a range of cycle temperature ratios (turbine inlet divided by compressor inlet temperature (CIT)) and compressor pressure ratios (CPR). The pressure ratio variations produce three distinct local optima for minimum reactor power, minimum radiator area and minimum mass at each temperature ratio (Trat). The two curves have been drawn through the locus of points representing the arithmetic average of the three local optima pressure ratios at each temperature ratio. The selected reference design point has a temperature ratio of 3.0 and compressor pressure ratio of 2.1 resulting in a system mass of 33.3 kg/kWe, radiator area of 200 m², and reactor power of 457 kWt. A 100 kWt reduction in reactor power results in a mass penalty of 7% and a radiator area penalty of 52%.

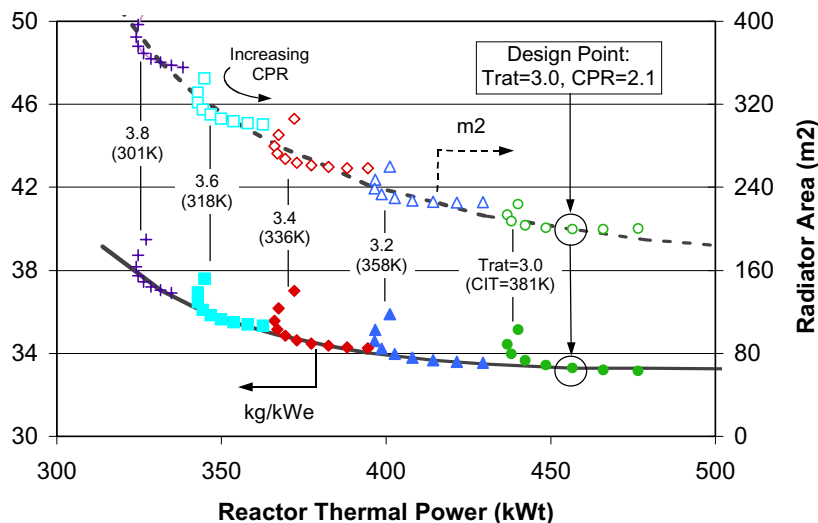

FIGURE 5. Reference Configuration Performance Trade-offs.

Table 1 summarizes the performance sensitivities associated with alternate power conversion architectures. The impact of increasing the number of converters to four is a 7% mass penalty, whereas a decrease in the number of converters to two results in a 8% mass savings. Eliminating the recuperator causes a 27% system mass increase and a dramatic 3X increase in radiator size. The excessively large radiator for the non-recuperated case resulted from the high cycle temperature ratio needed to meet the 500 kWt reactor thermal power constraint. For the configurations that include spares, the converters are sized so that if a loss occurs the remaining converters can still provide full system output power (i.e., 100 kWe). (Operationally, all of the converters would operate at partial power rather than maintaining spare units in a dormant standby condition.) The mass penalty of carrying a spare converter with a shared radiator configuration is 12%, while the mass penalty of carrying a spare converter and dedicated radiator is 18%. Based on these preliminary sensitivity studies, the converter size and the use of spares have a moderate impact on mass, and non-recuperated configurations are not favored.

TABLE 1. Performance Sensitivities Associated with Alternate Power Conversion Configurations.

Configuration	Converter Power (kW)	System Mass (kg/kWe)	Radiator Area (m²)
3 Recup. Converters, No Spares, Dedicated Radiators (3/0/3)	34.5	33.3	200
4 Recup. Converters (4/0/4)	25.9 (75%)	35.7 (107%)	205 (103%)
2 Recup. Converters (2/0/2)	51.8 (150%)	30.5 (92%)	193 (97%)
3 Non-recup. Converters (3/0/3)	34.5 (100%)	42.4 (127%)	610 (305%)
4 Recup. Converters, 1 Spare, Shared Radiator (4/1/1)	34.5 (100%)	37.1 (112%)	200 (100%)
4 Recup. Converters, 1 Spare, Dedicated Radiators (4/1/4)	34.5 (100%)	39.1 (118%)	266 (133%)

CONCLUSIONS

GRC is continuing the development of closed Brayton cycle power conversion as a stable and reliable power source for a variety of NASA missions and applications. Brayton systems, with either nuclear or solar heat sources, offer numerous benefits including high efficiency and long life. Brayton is especially well-suited to high power (100's of kilowatts) and high voltage (1000's of volts) applications such as Nuclear Electric Propulsion. The current GRC project is building on the heritage of previous efforts including the Brayton Rotating Unit, Brayton Isotope Power System, Solar Dynamic Power Module, and Solar Dynamic Ground Test Demonstration projects. The present effort is focusing on an in-house 2 kW advanced technology testbed and a 25 kW-class Brayton converter design. GRC is guiding the development of the high power design effort through analytical studies and hardware demonstrations to evaluate system performance of various configurations and architectures.

REFERENCES

- Davis, J.E., "Design and Fabrication of the Brayton Rotating Unit," NASA/CR-1870, March 1972.
- Houts, M., et. al., "Options for the Development of Space Fission Propulsion Systems," *Proceedings of the 2001 Space Technology and Applications International Forum (STAIF-2001)*, edited by Mohamed S. El Genk, 2001.
- McCormick, J.E., "Brayton Isotope Power System Phase 1 Final Report," Prepared for the Department of Energy, Report Number 31-2919, July 1978.
- Shaltens, Richard S. and Mason, Lee S., "800 Hours of Operational Experience From a 2 kWe Solar Dynamic System," NASA/TM-1999-208840, January 1999.
- Staff of the Solar Dynamic Power Systems Branch, "Solar Dynamic Power System Development for Space Station Freedom," NASA RP-1310, July 1993.

REPORT DOCUMENTATION PAGEForm Approved
OMB No. 0704-0188

Public reporting burden for this collection of information is estimated to average 1 hour per response, including the time for reviewing instructions, searching existing data sources, gathering and maintaining the data needed, and completing and reviewing the collection of information. Send comments regarding this burden estimate or any other aspect of this collection of information, including suggestions for reducing this burden, to Washington Headquarters Services, Directorate for Information Operations and Reports, 1215 Jefferson Davis Highway, Suite 1204, Arlington, VA 22202-4302, and to the Office of Management and Budget, Paperwork Reduction Project (0704-0188), Washington, DC 20503.

1. AGENCY USE ONLY (Leave blank)		2. REPORT DATE January 2002	3. REPORT TYPE AND DATES COVERED Technical Memorandum	
4. TITLE AND SUBTITLE Status of Brayton Cycle Power Conversion Development at NASA GRC			5. FUNDING NUMBERS WU-713-81-50-00	
6. AUTHOR(S) Lee S. Mason, Richard K. Shaltens, James L. Dolce, and Robert L. Cataldo				
7. PERFORMING ORGANIZATION NAME(S) AND ADDRESS(ES) National Aeronautics and Space Administration John H. Glenn Research Center at Lewis Field Cleveland, Ohio 44135-3191			8. PERFORMING ORGANIZATION REPORT NUMBER E-13108	
9. SPONSORING/MONITORING AGENCY NAME(S) AND ADDRESS(ES) National Aeronautics and Space Administration Washington, DC 20546-0001			10. SPONSORING/MONITORING AGENCY REPORT NUMBER NASA TM-2002-211304	
11. SUPPLEMENTARY NOTES Prepared for the Space Technology and Applications International Forum (STAIF-2002) sponsored by the American Institute of Aeronautics and Astronautics, Albuquerque, New Mexico, February 3-7, 2002. Responsible person, Lee S. Mason, organization code 5490, 216-977-7106.				
12a. DISTRIBUTION/AVAILABILITY STATEMENT Unclassified - Unlimited Subject Category: 20 Available electronically at http://gltrs.nasa.gov/GLTRS This publication is available from the NASA Center for AeroSpace Information, 301-621-0390.			12b. DISTRIBUTION CODE	
13. ABSTRACT (Maximum 200 words) The NASA Glenn Research Center is pursuing the development of Brayton cycle power conversion for various NASA initiatives. Brayton cycle power systems offer numerous advantages for space power generation including high efficiency, long life, high maturity, and broad scalability. Candidate mission applications include surface rovers and bases, advanced propulsion vehicles, and earth orbiting satellites. A key advantage is the ability for Brayton converters to span the wide range of power demands of future missions from several kilowatts to multi-megawatts using either solar, isotope, or reactor heat sources. Brayton technology has been under development by NASA since the early 1960's resulting in engine prototypes in the 2 to 15 kW-class that have demonstrated conversion efficiency of almost 30 percent and cumulative operation in excess of 40,000 hours. Present efforts at GRC are focusing on a 2 kW testbed as a proving ground for future component advances and operational strategies, and a 25 kW engine design as a modular building block for 100 kW-class electric propulsion and Mars surface power applications.				
14. SUBJECT TERMS Brayton cycle; Nuclear electric power generation; Nuclear electric propulsion			15. NUMBER OF PAGES 13	
			16. PRICE CODE	
17. SECURITY CLASSIFICATION OF REPORT Unclassified	18. SECURITY CLASSIFICATION OF THIS PAGE Unclassified	19. SECURITY CLASSIFICATION OF ABSTRACT Unclassified	20. LIMITATION OF ABSTRACT	