

National Aeronautics and  
Space Administration

Space Shuttle  
Mission STS-121:  
**The Second Step**





# CONTENTS

Section	Page
<b>STS-121 MISSION OVERVIEW: CONTINUING ON-ORBIT TESTING AND STATION MAINTENANCE</b> .....	<b>1</b>
<b>STS-121 TIMELINE OVERVIEW</b> .....	<b>5</b>
<b>MISSION OBJECTIVES</b> .....	<b>9</b>
<b>LAUNCH AND LANDING</b> .....	<b>11</b>
<b>LAUNCH</b> .....	<b>11</b>
<b>ABORT-TO-ORBIT (ATO)</b> .....	<b>11</b>
<b>TRANSATLANTIC ABORT LANDING (TAL)</b> .....	<b>11</b>
<b>RETURN-TO-LAUNCH-SITE (RTL)</b> .....	<b>11</b>
<b>LANDING</b> .....	<b>11</b>
<b>ABORT ONCE AROUND (AOA)</b> .....	<b>11</b>
<b>MISSION PROFILE</b> .....	<b>12</b>
<b>STS-121 DISCOVERY CREW</b> .....	<b>13</b>
<b>KEY MISSION PERSONNEL</b> .....	<b>18</b>
<b>RENDEZVOUS AND DOCKING</b> .....	<b>19</b>
<b>UNDOCKING, SEPARATION AND DEPARTURE</b> .....	<b>22</b>
<b>SPACEWALKS</b> .....	<b>23</b>
<b>EVA 1</b> .....	<b>23</b>
<b>EVA 2</b> .....	<b>29</b>
<b>EVA 3 (TENTATIVE)</b> .....	<b>30</b>
<b>PAYLOAD OVERVIEW</b> .....	<b>34</b>
<b>EXPERIMENTS</b> .....	<b>44</b>
<b>DETAILED SUPPLEMENTARY OBJECTIVES (DSO)</b> .....	<b>44</b>
<b>DETAILED TEST OBJECTIVES (DTO)</b> .....	<b>47</b>
<b>SHUTTLE (SORTIE) EXPERIMENTS</b> .....	<b>50</b>
<b>EXPERIMENTS DELIVERED TO ISS</b> .....	<b>51</b>

<b>Section</b>	<b>Page</b>
FUNGAL PATHOGENESIS, TUMORIGENESIS AND EFFECTS OF HOST IMMUNITY IN SPACE (FIT).....	52
ANALYSIS OF A NOVEL SENSORY MECHANISM IN ROOT PHOTOTROPISM (TROPI).....	53
<b>SPACE SHUTTLE SAFETY ENHANCEMENTS .....</b>	<b>54</b>
<b>OVERVIEW.....</b>	<b>54</b>
<b>PREPARING THE EXTERNAL TANK RETURN TO FLIGHT EXTERNAL TANK, ET-119 .....</b>	<b>55</b>
<b>ENHANCED SHUTTLE-BASED CAMERA VIEWS.....</b>	<b>59</b>
<b>IN-FLIGHT INSPECTION AND REPAIR .....</b>	<b>66</b>
<b>IMAGERY AND DATA COLLECTION FOR SPACE SHUTTLE LAUNCH AND LANDING .....</b>	<b>72</b>
<b>TILE REPAIR ABLATOR DISPENSER (T-RAD).....</b>	<b>82</b>
<b>CONTINGENCY SHUTTLE CREW SUPPORT (CSCS) .....</b>	<b>83</b>
<b>SHUTTLE REFERENCE DATA .....</b>	<b>85</b>
<b>ACRONYMS AND ABBREVIATIONS .....</b>	<b>98</b>
<b>MEDIA ASSISTANCE .....</b>	<b>115</b>
<b>PUBLIC AFFAIRS CONTACTS .....</b>	<b>116</b>

# FIGURES

Figure	Page
DISCOVERY CREW .....	1
FULL VIEW OF INTERNATIONAL SPACE STATION .....	2
STEVE LINDSEY.....	2
DISCOVERY UNDERSIDE VIEW.....	3
ASTRONAUT MICHAEL E. FOSSUM .....	3
RAFFAELLO IN THE AFT BAY OF DISCOVERY.....	4
OBSS INSPECTION OF DISCOVERY'S NOSE CAP HEAT SHIELD.....	5
INSTALLATION OF LEONARDO WITH CANADARM2 .....	7
DISCOVERY UNDOCKING FROM ISS WITH THE OBSS IN THE HAND-OFF POSITION .....	7
STS-121 DISCOVERY CREW .....	13
STS-121 PATCH.....	14
COMMANDER STEVEN LINDSEY.....	14
PILOT MARK KELLY.....	14
MIKE FOSSUM .....	15
LISA NOWAK.....	15
STEPHANIE WILSON .....	16
PIERS SELLERS.....	16
THOMAS REITER.....	16
LÉOPOLD EYHARTS .....	17
STS-121 AT ANGLE.....	19
RPM START (800 MM LENS) .....	19
SHUTTLE BELLY-UP (400 MM LENS).....	19
ZVEZDA SERVICE MODULE .....	20
RENDEZVOUS APPROACH PROFILE.....	20
APPROACH PROFILE .....	21
IMAGERY OF DISCOVERY UPPER SURFACE USING 400 AND 800 MM DIGITAL CAMERA LENSES.....	21
IMAGERY OF DISCOVERY BELLY USING 400 AND 800 MM DIGITAL CAMERA LENSES .....	21
IUA WITH TUS CABLE ROUTED THROUGH MECHANISM .....	24
ASTRONAUT PIERS J. SELLERS PARTICIPATES IN A SIMULATION .....	24
ENGINEERING MODEL OF THE APFR AND LOAD CELL CONFIGURATION .....	25
ROBOTIC ARM CLIMB POSITION .....	26
FIRST POSITION OF THE ROBOTIC ARM .....	26

Figure	Page
SECOND POSITION OF THE ROBOTIC ARM .....	27
INTERMEDIATE POSITION OF THE ROBOTIC ARM .....	27
THIRD POSITION OF THE ROBOTIC ARM .....	28
FINAL POSITION OF THE ROBOTIC ARM .....	29
ENGINEERING IMAGERY OF THE SO TRUSS SEGMENT BEFORE LAUNCH .....	30
SELLERS AND FOSSUM PRACTICE HAND OVER OF TUS-RA DURING SIMULATED SPACEWALK .....	30
SELLERS AND FOSSUM PRACTICE REPLACING TUS DURING SIMULATED SPACEWALK .....	30
INFRARED CAMERA SIMULATION HARDWARE A .....	31
CONFIGURATION OF THE SAMPLES IN THE DTO PALLET .....	31
RCC REPAIR TOOLS TO BE USED DURING THE TEST .....	32
DISCOVERY PAYLOAD DIAGRAM .....	34
LEONARDO IS LOWERED TOWARD THE CARGO ELEMENT WORK STAND .....	35
CANADARM2 GRASPS THE RAFFAELLO .....	36
TECHNICIANS INSPECT THE MINUS EIGHTY LAB FREEZER FOR ISS .....	38
ESA ASTRONAUT REINHOLD EWALD INSERTS AN EXPERIMENT CONTAINER INTO THE EMCS ENGINEERING MODEL .....	40
PLANT CULTIVATION CHAMBER INSIDE EXPERIMENT CONTAINER .....	40
THE PERCUTANEOUS ELECTRICAL MUSCLE STIMULATOR .....	41
EXTERNAL ACTIVE THERMAL CONTROL SYSTEM PUMP MODULE .....	41
PAL RAMPS .....	55
EXTERNAL TANK WITH PAL RAMPS REMOVED .....	56
ICE/FROST RAMPS .....	57
CURRENT ICE/FROST RAMP .....	58
BIPOD INSTALLATION .....	58
CAMERAS ON THE SPACE SHUTTLE BOOSTERS, EXTERNAL TANK AND ORBITER .....	59
SHUTTLE ORBITER-BASED PHOTOGRAPHY FOR STS-121 ASCENT .....	60
EXTERNAL TANK CAMERA OVERVIEW .....	61
SRB-MOUNTED CAMERAS .....	62
ET RING CAMERA HOUSING INSTALLED .....	62
FORWARD SKIRT AFT-POINTING CAMERA PROTOTYPE HOUSING .....	62
CAMERA CONFIGURATION .....	63
RIGHT-HAND UMBILICAL WELL .....	63
DIGITAL UMBILICAL STILL CAMERA SYSTEM .....	64
EVA FLASH MECHANICAL DESIGN .....	65

Figure	Page
ORBITER BOOM SENSOR SYSTEM INSTALLED ON STARBOARD SILL .....	66
INSPECTION SENSORS .....	68
LCS, ITVC CAMERA, LDRI, AND PAN/TILT UNIT .....	68
ITVC, LCS, AND LDRI IMAGES .....	70
CAMERA TYPES AND LOCATIONS .....	72
SHORT-RANGE TRACKING CAMERA .....	73
LONG-RANGE TRACKER .....	73
KINETO TRACKING MOUNT TRACKER .....	74
MLP DECK .....	75
PAD PERIMETER .....	75
SHORT-RANGE CAMERA CONFIGURATION .....	75
MEDIUM-RANGE CAMERA CONFIGURATION .....	76
LONG-RANGE CAMERA CONFIGURATION .....	76
WB-57 AIRCRAFT .....	77
SRB SEPARATION .....	77
C-BAND RADAR .....	78
X-BAND RADAR .....	79
WING LEADING EDGE IMPACT DETECTION SYSTEM .....	81
WING LEADING EDGE IMPACT DETECTION SYSTEM .....	82
WING LEADING EDGE IMPACT DETECTION SYSTEM .....	82
TILE REPAIR ABLATOR DISPENSER (T-RAD) .....	83
T-RAD DELIVERY SYSTEM .....	83





## STS-121 MISSION OVERVIEW: CONTINUING ON-ORBIT TESTING AND STATION MAINTENANCE



**(5 April 2006) — These seven astronauts take a break from training to pose for the STS-121 crew portrait. From the left are astronauts Stephanie D. Wilson, Michael E. Fossum, both mission specialists; Steven W. Lindsey, commander; Piers J. Sellers, mission specialist; Mark E. Kelly, pilot; European Space Agency (ESA) astronaut Thomas Reiter of Germany; and Lisa M. Nowak, both mission specialists. The crew members are attired in training versions of their shuttle launch and entry suit.**

The crew of Space Shuttle Discovery will continue to test new equipment and procedures that increase the safety of space shuttles during the STS-121 mission. The flight to the International Space Station (ISS) also will

deliver critical supplies and cargo to the complex for repair and future expansion of the outpost.

The focus of the mission is to carry on analysis of safety improvements that debuted on the

first Return to Flight mission, STS-114, and build upon those tests. This mission will continue testing the External Tank designs and processes that minimize potentially damaging debris during launch, ground and flight camera systems to observe the shuttle environment during launch and on orbit, and techniques for in-flight inspection and repair of the shuttle's Thermal Protection System (TPS), or heat shield.

Two spacewalks are planned. They are devoted to maintenance of the space station and additional testing of heat shield inspection and repair materials, tools and techniques.

During the flight, mission managers expect to evaluate the high probability of shuttle consumables supporting an extra day for the mission. If an extra day is available, the crew and flight control team are training for a third spacewalk that focuses on reinforced carbon-carbon (RCC) inspection and repair.



**Backdropped by the Earth below, this full view of the International Space Station was photographed by an STS-114 crew member onboard the Space Shuttle Discovery**

Discovery will be docked to the International Space Station for the majority of the mission. STS-121 is designated Utilization and Logistics Flight-1.1 (ULF-1.1) in the space station

assembly sequence. The mission was added to the sequence as an additional mission to complete Return to Flight on-orbit testing before resuming major assembly of the space station. The mission's objectives for the station will be maintenance work and the delivery of equipment, supplies, experiments and spare parts in support of operations and future station assembly missions.

Discovery will deliver a third crew member to live aboard the station. It will be the first time a three-person crew resides on station for a long duration since the Expedition 6 crew returned to Earth May 4, 2003, in Kazakhstan. Without the space shuttle to ferry equipment to the station after the Columbia accident, only two people could be supported onboard until the necessary provisions were in place. To help deliver tons of supplies, Discovery will carry an Italian-built pressurized cargo container called Leonardo, in its cargo bay.



Steve Lindsey

Commanding the STS-121 mission aboard the Space Shuttle Discovery is Steve Lindsey, an Air Force colonel. Joining him will be Pilot Mark Kelly, a Navy commander, and mission specialists Michael Fossum (Fōs-sūm), Stephanie Wilson, Piers (Peers) Sellers and Navy Cmdr. Lisa Nowak (Nō-wăc). European Space Agency (ESA) astronaut Thomas (Toe-mahs') Reiter (Rīt-ūr) will ride to space with the shuttle crew and remain on the station, joining the Expedition 13 mission already in progress. Reiter is the first ESA long-duration space station crew member and will remain on board for six to seven months to work with the Expedition 13 and Expedition 14 crews under a contract between ESA and the Russian Federal Space Agency, Roscosmos.

Expedition 13 Commander Pavel Vinogradov and Flight Engineer Jeffrey Williams have been aboard the station since arriving on a Russian Soyuz spacecraft on April 1. The station crew members will help with the transfer of supplies to and from the cargo carrier Leonardo and lend their expertise in airlock and robotic system operations.

The mission's top priority is to inspect all of the reinforced carbon-carbon heat protection material on Discovery's wing leading edge panels and to downlink the data for evaluation on the ground. Second on the list of priorities is inspecting all of the shuttle's silicon-based tiles.

The on-orbit inspections will be carried out using a variety of methods, including umbilical well and hand-held photography and video of the external tank after it is jettisoned. En route to the station the day after launch, the crew will use a 50-foot-long Orbiter Boom Sensor System (OBSS) tipped with two types of lasers and a high-resolution television camera to inspect key areas of the wings for any sign of damage that

may have occurred during launch. This boom nearly doubles the length of the robotic capability of the shuttle crane. There are additional inspections using this equipment scheduled the day before and the day of undocking from the space station.



An inspection conducted by the station crew will focus on the underside of Discovery at a distance of 600 feet before docking. The shuttle will be carefully rotated under command of Lindsey through a back-flip allowing the station crew to train cameras on the shuttle as it approaches. This maneuver, the rendezvous pitch maneuver (RPM), was first performed during the STS-114 mission.



**Astronaut Michael E. Fossum, STS-121 mission specialist, participates in a spacesuit fit check in the Space Station Airlock Test Article (SSATA) in the Crew Systems Laboratory at the Johnson Space Center.**

Two 6½ hour spacewalks are scheduled for Sellers and Fossum on the fifth and seventh days of the mission. If an additional day is available, a third spacewalk will be scheduled on the ninth day.

For the first spacewalk, the crew members will use the 50-foot robotic arm inspection boom as a potential work platform for hard-to-reach repair sites on the bottom of the orbiter. They also will begin maintenance of the station's mobile transporter (MT) by safing or replacing a cable cutter on one side of the unit to allow the robotic system to be translated in support of the second spacewalk.

During the second spacewalk, on the other side of the MT, the crew will replace a reel assembly and the detached cable that was inadvertently cut and swap out the cable cutter with a disabled unit. The crew also will install a spare pump for the thermal control system on the outside of the station's Quest airlock for future use. The replacement cable reel and pump module will be delivered on a carrier in Discovery's cargo bay.

If an extra day is available, the third spacewalk will include tasks to test techniques for using an infrared camera for inspecting and materials for repairing the RCC segments that protect the orbiter's nose cone and wing leading edges.

STS-121 is scheduled to launch during a planning window extending July 1 to 19. Discovery will launch from Launch Pad 39B at Kennedy Space Center, Fla., and rendezvous with the International Space Station on flight day 3.

The Leonardo cargo carrier housed in Discovery's payload bay will be berthed to the



**The Multi-Purpose Logistics Module Raffaello stands out in the aft bay of Discovery during the STS-114 mission**

space station Unity module's Earth-facing port on flight day 4. This will be the fourth trip to the station for Leonardo, the first of three such Italian-built cargo carriers to be put into service. Leonardo flew to space for the first time aboard Discovery during STS-102 in February 2001.

Included in Leonardo's cargo is the Minus Eighty Laboratory Freezer for ISS (MELFI) that will store extremely cold research samples, the European Modular Cultivation System for biological science experiments and the oxygen generation system (OGS) that will be activated by a station crew later to supplement oxygen supplies onboard and a new cycle ergometer for the station crew. Equipment and supplies no longer needed on the station will be moved to Leonardo before it is unberthed on flight day 10 and put back into Discovery's cargo bay for return to Earth.

Undocking is set for flight day 11. Discovery's crew will make final preparations for the return home on flight day 12, with landing at the Kennedy Space Center's Shuttle Landing Facility on flight day 13.

# STS-121 TIMELINE OVERVIEW

## (IF ONLY TWO SPACEWALKS ARE CONDUCTED)

### FLIGHT DAY 1:

- Launch
- Payload Bay Door Opening
- Ku-Band Antenna Deployment
- Shuttle Robot Arm Power Up
- External Tank Handheld Video and Wing Leading Edge Sensor Data Downlink

### FLIGHT DAY 2:

- Shuttle Robot Arm Checkout
- Shuttle Robot Arm Grapple of Orbiter Boom Sensor System (OBSS)
- Inspection of Shuttle Thermal Protection System and Wing Leading Edge reinforced carbon-carbon (RCC)
- Spacesuit Checkout
- Orbiter Docking System Outer Ring Extension
- Airlock Preparations
- Rendezvous Tool Checkout

### FLIGHT DAY 3:

- Rendezvous Operations
- Terminal Initiation Engine Firing
- Rendezvous Pitch Maneuver and ISS Digital Photography of Discovery



**Artist's rendering of the OBSS inspection of Discovery's nose cap heat shield.**

- Docking to the International Space Station
- Hatch Opening and Welcoming by Expedition 13 Crew
- Thomas Reiter Soyuz Seatliner Transfer and Installation (becomes part of Expedition 13 crew)
- Recharge Oxygen Orifice Bypass Assembly (ROOBA) Leak Check and Checkout
- Station Robot Arm Grapple of OBSS and Handoff to Shuttle Robot Arm

### FLIGHT DAY 4:

- Station Robot Arm Grapple of Leonardo Multi-Purpose Logistics Module (MPLM) and Installation on Unity Module
- Station Robotic Arm Walkoff from Destiny Laboratory to Mobile Base System
- OBSS Survey of Shuttle Reinforced Carbon-Carbon
- MPLM Ingress and Start of Cargo Transfers

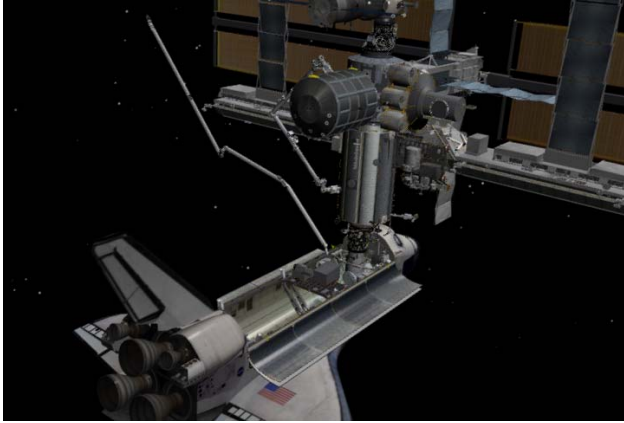

Artist's rendering of the installation of Leonardo with Canadarm2.

### FLIGHT DAY 5:

- EVA 1 (Zenith Integrated Umbilical Assembly Replacement on Mobile Transporter; Orbiter Boom Sensor System Loads Evaluation)
- Cargo Transfers Continue

### FLIGHT DAY 6:

- Cargo Transfers Continue
- Joint Crew News Conference

### FLIGHT DAY 7:

- EVA 2 (Pump Module Transfer to External Stowage Platform-2; Trailing Umbilical System Replacement on Mobile Transporter)
- Station Robot Arm Walkoff from Mobile Base System to Destiny Laboratory
- Cargo Transfers Continue

### FLIGHT DAY 8:

- Cargo Transfers Continue

### FLIGHT DAY 9:

- Crew Off-Duty Period

### FLIGHT DAY 10:

- Final Cargo Transfers
- MPLM Egress and Deactivation
- Station Robot Arm Detachment of MPLM from Unity for Berthing in Discovery Payload Bay
- Station Robot Arm Grapple of OBSS from Shuttle Robot Arm for Final Berthing
- Shuttle Robot Arm/OBSS Late Inspection of Discovery's Port Wing

### FLIGHT DAY 11:

- Final Farewells and Hatch Closing
- Undocking of Discovery from ISS
- Final Separation Maneuver
- Shuttle Robot Arm/OBSS Late Inspection of Discovery's Starboard Wing and Nose Cap
- Crew Off-Duty Period



Artist's rendering of Discovery undocking from ISS with the OBSS in the hand-off position.

**FLIGHT DAY 12:**

- Flight Control System Checkout
- Reaction Control System Hot-Fire Test
- Cabin Stowage
- Deorbit Timeline Review
- Ku-Band Antenna Stowage

**FLIGHT DAY 13:**

- Deorbit Preparations
- Payload Bay Door Closing
- Deorbit Burn
- KSC Landing

**(IF THREE SPACEWALKS ARE CONDUCTED)**

Flight days 1 - 7 would remain the same, but activities on the following days would change.

**FLIGHT DAY 8:**

- Cargo Transfers Continue
- Crew Off-Duty Period

**FLIGHT DAY 9:**

- EVA 3 (RCC Crack Repair Technique Demonstration)

**FLIGHT DAY 10:**

- Cargo Transfers Continue
- Crew Off-Duty Period

**FLIGHT DAY 11:**

- Final Cargo Transfers
- MPLM Egress and Deactivation
- Station Robot Arm Detachment of MPLM from Unity for Berthing in Discovery Payload Bay
- Station Robot Arm Grapple of OBSS from Shuttle Robot Arm for Final Berthing
- Shuttle Robot Arm/OBSS Late Inspection of Discovery's Port Wing

**FLIGHT DAY 12:**

- Final Farewells and Hatch Closing
- Undocking of Discovery from ISS
- Final Separation Maneuver
- Shuttle Robot Arm/OBSS Late Inspection of Discovery's Starboard Wing and Nose Cap

**FLIGHT DAY 13:**

- Flight Control System Checkout
- Reaction Control System Hot-Fire Test
- Cabin Stowage
- Deorbit Timeline Review
- Ku-Band Antenna Stowage

**FLIGHT DAY 14:**

- Deorbit Preparations
- Payload Bay Door Closing
- Deorbit Burn
- KSC Landing





## MISSION OBJECTIVES

Objectives for the STS-121 Space Shuttle mission include (in order of priority):

- Perform orbiter reinforced carbon-carbon (RCC) inspection using the Orbiter Boom and Sensor System (OBSS) attached to the Shuttle Remote Manipulator System (SRMS) and downlink the OBSS sensors data to the ground for evaluation.
- Perform orbiter tile inspection using ISS imagery during the Rendezvous Pitch Maneuver (RPM).
- Perform orbiter RCC inspection of the wing leading edge of both wings and nose cap prior to deorbit and landing to detect micrometeoroid orbital debris (MMOD) damage and downlink the sensor data to the ground for evaluation.
- Transfer mandatory quantities of water from the shuttle to the station.
- Augment Expedition 13 crew, transfer mandatory crew augmentation cargo and perform mandatory tasks consisting of individual equipment liner kit, or Soyuz seatliner (IELK), and Sokol suit checkout.
- Remove and replace the failed trailing umbilical system (TUS)-reel assembly (RA) and interface umbilical assembly (IUA) on the station with the new TUS-RA and IUA. Return the failed TUS-RA on the integrated cargo carrier (ICC) and return the failed IUA on the middeck.
- Berth Multi-Purpose Logistics Module (MPLM) to Unity Node 1. Activate and check out MPLM.
- Perform Detailed Test Objective (DTO) 849 - OBSS/SRMS loads characterization with extravehicular activity (EVA) crew members during an EVA (see "Spacewalk" and "Detailed Supplementary Objectives and Detailed Test Objectives" sections for details).
- Perform DTO 850 - water spray boiler cooling with water/ propylene glycol monomethyl ether (PGME) mixture.
- Transfer critical cargo which includes items to ensure crew and vehicle safety, items that are required to support flight and stage objectives, samples and data collection items for return, hardware for return and refurbishment, and increment science objectives and last flight opportunity items before implementation.
- Perform seven hours of crew handover for augmented crew member.
- Return MPLM to orbiter payload bay.
- Remove the pump module (PM) with fixed grapple bar (FGB) installed from the ICC and install on the external stowage platform 2 (ESP2).
- Transfer and install the oxygen generation system (OGS).
- Transfer and install the Minus Eighty Degrees Laboratory Freezer (MELFI).
- Transfer and install the starboard common cabin air assembly (CCAA) heat exchanger.
- Perform recharge oxygen orifice bypass assembly (ROOBA) checkout.

- Disassemble and exchange cycle ergometer with vibration isolation system (CEVIS).
- Transfer required nitrogen from the orbiter to the station Quest Airlock high pressure gas tank (HGPT).
- Perform Station Development Test Objective (SDTO) 12004-U, shuttle booster fan bypass.
- Transfer remaining cargo.
- Remove and replace the Microgravity Science Glovebox (MSG) front window.
- Swap ISS and orbiter printer.
- Transfer oxygen from the orbiter to the station Quest Airlock HGPT, if required.
- Perform daily ISS payload status checks, as required.
- Reboost ISS with the orbiter to no more than 186.7 nautical miles, or 214.9 statute miles, average orbital altitude, if propulsive consumables are available.
- Perform middeck sortie payload activities.
- Perform ram burn observation (RAMBO) payload operations.
- Perform Maui Analysis of Upper-Atmospheric Injections (MAUI) payload operations.
- Perform an imagery survey of the ISS exterior during an orbiter flyaround after undocking, if propulsive consumables are available.
- Perform U.S. operating segment (USOS)/Russian segment (RS) payload research operations tasks.
- Perform DTO 852, SRMS On-orbit loads, heavy payloads.
- Perform station development test objective (SDTO) 13005-U, ISS structural life validation and extension for orbiter reboost, integrated wireless instrumentation system (IWIS) only if crew time is available.
- Perform station development test objective (SDTO) 13005-U, ISS structural life validation and extension for orbiter undocking, integrated wireless instrumentation system (IWIS) only if crew time is available.
- Perform ISS-approved EVA get-ahead tasks.

# LAUNCH AND LANDING

## LAUNCH

As with all previous space shuttle launches, Discovery on STS-121 will have several modes available that could be used to abort the ascent if needed due to engine failures or other systems problems. Shuttle launch abort philosophy aims toward safe recovery of the flight crew and intact recovery of the orbiter and its payload. Abort modes include:

### ABORT-TO-ORBIT (ATO)

Partial loss of main engine thrust late enough to permit reaching a minimal 105 by 85 nautical mile orbit with orbital maneuvering system engines.

### TRANSATLANTIC ABORT LANDING (TAL)

Loss of one or more main engines midway through powered flight would force a landing at either Zaragoza, Spain; Moron, Spain; or Istres, France. For launch to proceed, weather conditions must be acceptable at one of these TAL sites.

## RETURN-TO-LAUNCH-SITE (RTL)

Early shutdown of one or more engines, and without enough energy to reach Zaragoza, would result in a pitch around and thrust back toward KSC until within gliding distance of the Shuttle Landing Facility. For launch to proceed, weather conditions must be forecast to be acceptable for a possible RTL landing at KSC about 20 minutes after liftoff.

## LANDING

The primary landing site for Discovery on STS-121 is the Shuttle Landing Facility at Kennedy Space Center. Alternate landing sites that could be used if needed due to weather conditions or systems failures are at Edwards Air Force Base, Calif., and White Sands Space Harbor, N.M.

### ABORT ONCE AROUND (AOA)

An AOA is selected if the vehicle cannot achieve a viable orbit or will not have enough propellant to perform a deorbit burn, but has enough energy to circle the Earth once and land about 90 minutes after liftoff.



# MISSION PROFILE

## CREW

<b>Commander:</b>	Steve Lindsey
<b>Pilot:</b>	Mark Kelly
<b>Mission Specialist 1:</b>	Mike Fossum
<b>Mission Specialist 2:</b>	Lisa Nowak
<b>Mission Specialist 3:</b>	Stephanie Wilson
<b>Mission Specialist 4:</b>	Piers Sellers
<b>Mission Specialist 5:</b>	Thomas Reiter

## LAUNCH

<b>Orbiter:</b>	Discovery (OV-103)
<b>Launch Site:</b>	Kennedy Space Center Launch Pad 39B
<b>Launch Date:</b>	No earlier than July 1, 2006
<b>Launch Time:</b>	3:49 p.m. EDT (Preferred in-plane launch time for 7/1)
<b>Launch Window:</b>	5 minutes
<b>Altitude:</b>	122 nautical miles (140 Statute Miles) Orbital insertion; 185 NM (212 SM) rendezvous
<b>Inclination:</b>	51.6 degrees
<b>Duration:</b>	11 days 19 hours 12 minutes

## VEHICLE DATA

<b>Shuttle Liftoff Weight:</b>	4,523,850 pounds
<b>Orbiter/Payload Liftoff Weight:</b>	266,962 pounds
<b>Orbiter/Payload Landing Weight:</b>	225,741 pounds
<b>Software Version:</b>	OI-30

## Space Shuttle Main Engines:

<b>SSME 1:</b>	2045
<b>SSME 2:</b>	2051
<b>SSME 3:</b>	2056
<b>External Tank:</b>	ET-119
<b>SRB Set:</b>	BI-126
<b>RSRM Set:</b>	93

## SHUTTLE ABORTS

### Abort Landing Sites

<b>RTLS:</b>	Kennedy Space Center Shuttle Landing Facility
<b>TAL:</b>	Primary – Zaragoza; alternates Moron and Istres
<b>AOA:</b>	Primary – Kennedy Space Center Shuttle Landing Facility; alternate White Sands Space Harbor

### Landing

<b>Landing Date:</b>	No earlier than July 13, 2006
<b>Landing Time:</b>	10:46 a.m. EDT
<b>Primary landing Site:</b>	Kennedy Space Center Shuttle Landing Facility

## PAYLOADS

- Multi-Purpose Logistics Module (MPLM)
- Integrated Cargo Carrier (ICC)
- Lightweight Multi-Purpose Experiment  
Structure Carrier (LMC)



## STS-121 DISCOVERY CREW

The STS-121 crew was first named in December 2003 after the flight was added to the space shuttle schedule to help accommodate the growing list of requirements originally assigned to the first Return to Flight mission, STS-114. The initial crew included Commander Steven W. Lindsey, an Air Force colonel, Pilot Mark E. Kelly, a Navy commander, and mission specialists Carlos I. Noriega and Michael E. Fossum.

Noriega was replaced by Piers J. Sellers in July 2004 because of a temporary medical condition.

Mission specialists Lisa M. Nowak, a Navy commander, and Stephanie D. Wilson were added to the flight in November 2004.

The mission was declared a crew rotation flight when NASA determined returning to a three-person crew aboard the International Space Station would be possible following the first two shuttle supply missions. Thomas Reiter was added to the flight in July 2005.

Short biographical sketches of the crew follow with detailed background available at: <http://www.jsc.nasa.gov/Bios/> and <http://www.esa.int/esaHS/astronauts.html>





The STS-121 patch depicts the space shuttle docked with the International Space Station in the foreground, overlaying the astronaut symbol with three gold columns and a gold star. The ISS is shown in the configuration that it will be in during the STS-121 mission. The background shows the nighttime Earth with a dawn breaking over the horizon.

Commander Steven Lindsey is a veteran of three spaceflights and a second-time commander who has overall responsibility for the on-orbit execution of the mission, orbiter systems operations, and flight operations including landing the orbiter. In addition, he will fly the shuttle in a procedure called the rendezvous pitch maneuver while Discovery is 600 feet below the station before docking to enable the ISS crew to photograph the orbiter's heat shield. He will then dock Discovery to the station. He will also be heavily involved in inspections of Discovery's heat shield and transferring cargo to and from the shuttle.



**Commander Steven Lindsey**

Pilot Mark Kelly is flying for the second time and will be responsible for systems operations and assisting in the rendezvous and docking to the International Space Station. He will also serve as the intravehicular activity crew member helping to suit up and choreograph spacewalkers Piers Sellers and Michael Fossom during their spacewalks. In addition, he will be heavily involved in inspections of Discovery's heat shield and transferring cargo to and from the shuttle. He will undock Discovery from the station at the end of the mission.



**Pilot Mark Kelly**



Mission Specialist 1 (MS1) Michael Fossum will make his first venture into space. Fossum will perform two to three spacewalks, as EV2 with his colleague Piers Sellers, to test shuttle heat shield inspection and repair techniques. Testing will include evaluating the robotic boom extension as a work platform and testing repair materials and hardware for damaged shuttle heat shield components. He will also continue International Space Station assembly by replacing failed hardware and installing spare parts on the outside of the complex. Fossum will also assist with inspections of Discovery's heat shield. Fossum will be seated on the flight deck for launch and the middeck for landing.



**Mike Fossum**

Mission Specialist 2 (MS2) is astronaut Lisa Nowak, making her first flight into space. She will serve as the flight engineer on STS-121, adding a third set of eyes on orbiter systems for

the commander and the pilot on the flight deck during launch and landing. As a robotic arm operator, she will maneuver her crewmates and hardware during the two to three spacewalks using the shuttle arm on the first and the station arm for the second and third spacewalks. She will also perform heat shield inspections with the orbiter boom sensor system and use the station robotic arm to handoff the boom to the shuttle arm. During the rendezvous, docking and undocking, she will manage computers, lasers, cameras, and the orbiter docking system.



**Lisa Nowak**

Mission Specialist 3 (MS3) is astronaut Stephanie Wilson. She is making her first flight into space. She will serve as the overall lead for transferring supplies from the shuttle's cargo module to the station. She also will serve as a robotic arm operator, using the space station robotic arm to install the Leonardo cargo module onto the station and to handoff the boom to the shuttle arm, and use the orbiter boom sensor system to inspect Discovery's heat shield. Prior to the spacewalks, she will assist with suit-up of the spacewalkers. During the rendezvous, docking and undocking, she will manage the hand-held laser and the orbiter docking system. Wilson will be seated on the middeck for launch and the flight deck for landing.



**Stephanie Wilson**

Mission Specialist 4 (MS4) is astronaut Piers Sellers, a veteran of one spaceflight. His main objective is to lead and perform two to three spacewalks, as EV1 along with his spacewalking colleague, Michael Fossum. During the spacewalks, they will test shuttle heat shield inspection and repair techniques. Testing will include evaluation of the robotic boom extension as a work platform and testing of repair materials and hardware for damaged heat shield components. He will also continue International Space Station assembly by replacing failed hardware and installing spare parts on the outside of the complex. Sellers will be seated on the middeck for launch and landing.



**Piers Sellers**

International Space Station Flight Engineer Thomas Reiter (FE2), representing the European Space Agency (ESA), is flying to the space station aboard Discovery. He will lead the transfer of supplies from the shuttle's cargo module to the space station during the spacewalks and he will assist with suit-up prior to the spacewalks. He is conducting his second long-duration spaceflight mission. He spent 179 days in space in 1995-1996 on a mission to the Russian Mir space station during which he conducted two spacewalks and about 40 European scientific experiments. Reiter is the first ESA astronaut to live aboard the International Space Station for a long-term mission. Reiter will work on the station as part of an agreement between the Russian Federal Space Agency and ESA. Reiter will be on the middeck for launch and remain on the space station until the STS-116 space shuttle, or a Soyuz, mission.



**Thomas Reiter**

ESA astronaut Léopold Eyharts is serving as Reiter's backup for the long-duration space station mission and would be conducting his second spaceflight if needed. His previous mission in 1998 was aboard the Russian Mir space station during which he performed various French experiments in the area of medical research, neuroscience, biology, fluid physics and technology.



**Léopold Eyharts**



# KEY MISSION PERSONNEL

## KEY CONSOLE POSITIONS FOR STS-121

	<u>Flt. Director</u>	<u>CAPCOM</u>	<u>PAO</u>
<b>Ascent</b>	Steve Stich	Steve Frick Rick Sturckow (Wx)	Rob Navias
<b>Orbit 1 (Lead)</b>	Tony Ceccacci	Rick Mastracchio	Kylie Clem (Lead)
<b>Orbit 2</b>	Norm Knight	Lee Archambault	Kelly Humphries
<b>Planning</b>	Paul Dye	Steve Swanson	John Ira Petty Nicole Cloutier Lemasters
<b>Entry</b>	Steve Stich	Steve Frick Rick Sturckow (Wx)	Kelly Humphries
<b>ISS Orbit 1</b>	Annette Hasbrook	Megan McArthur	n/a
<b>ISS Orbit 2 (Lead)</b>	Rick LaBrode	Julie Payette	n/a
<b>ISS Orbit 3</b>	Matt Abbott	Thadd Bowers	n/a
<b>Mission Control, Korolev, Russia</b>	Cathy Koerner	n/a	n/a

**JSC PAO Representative at KSC for Launch** – Kyle Herring

**KSC Launch Commentator** – Bruce Buckingham

**KSC Launch Director** – Mike Leinbach

**NASA Launch Test Director** – Jeff Spaulding



## RENDEZVOUS AND DOCKING

Discovery's approach to the International Space Station during the STS-121 rendezvous and docking process will include a tricky maneuver first demonstrated on STS-114. The orbiter will be commanded to conduct a back flip, enabling station crew members to take digital images of the shuttle's heat shield.



With Commander Steve Lindsey at the controls, Discovery will perform the 360-degree pitch-around maneuver with the orbiter about 600 feet below the station. The flip will take about nine minutes to complete, offering Expedition 13 Commander Pavel Vinogradov and Flight Engineer Jeffrey Williams time to photograph tile surface imagery of Discovery.

The photos will then be downlinked through the station's Ku-band communications system for analysis by systems engineers and mission managers.

The photos will be taken out of windows 6 and 7 in the Zvezda service module with Kodak DCS 760 digital cameras and 400mm and 800mm lenses. The imagery during the rendezvous pitch maneuver (RPM) is among several inspection procedures instituted after the Columbia accident designed to detect and determine the extent of any damage the orbiter's protective tiles and reinforced carbon-carbon surfaces might have sustained.

The sequence of events that brings Discovery to its docking with the station begins with the precisely timed launch of the shuttle, placing the orbiter on the correct trajectory and course for its two-day chase to arrive at the station. During the first two days of the mission, periodic engine firings will gradually bring Discovery to a point about 9½ miles behind the station, the starting point for a final approach.

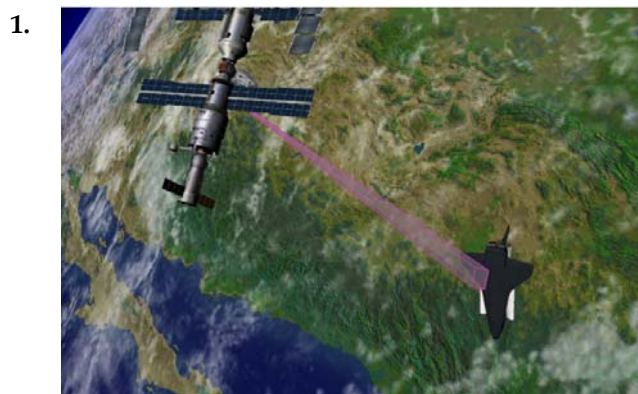

1. 800 mm lens
2. 400 mm lens

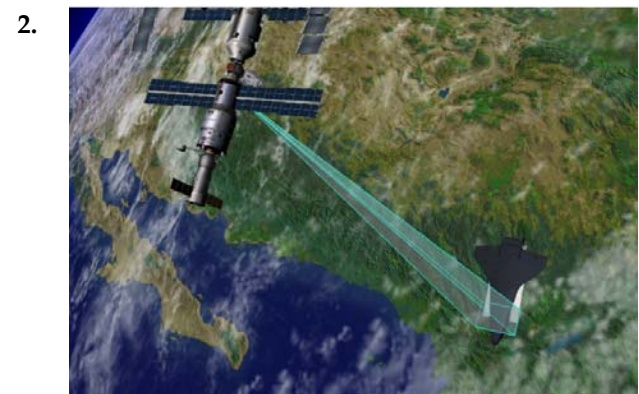

About 2½ hours before the scheduled docking time on flight day 3, Discovery will reach that point, about 50,000 feet behind the ISS. There, Discovery's jets will be fired in a terminal initiation (TI) burn to begin the final phase of the rendezvous. Discovery will close the final miles to the station during the next orbit.

As Discovery moves closer to the station, the shuttle's rendezvous radar system and trajectory control sensor (TCS) will begin tracking the complex, and providing range and closing rate information to the crew. During the final approach, Discovery will execute several small mid-course corrections at regular intervals with its steering jets. That will place Discovery at a point about 1,000 feet directly below the station where Lindsey will take over the manual flying of the shuttle up the R-Bar, or radial vector toward the complex, the imaginary line drawn between the station and the Earth.



Station crew members will use Earth-facing windows in the Zvezda Service Module to take photographs during the Rendezvous Pitch Maneuver.

### Rendezvous Approach Profile

EVENT	
1	1000 FT RANGE RATE GATE (RDOT = -1.3 FPS) TRANSITION TO LOW <sub>2</sub>
2	ORBITER ACQUIRES R-BAR
3	600 FT (RDOT = -0.1 FPS) BEGIN 1 DEG/SEC POSITIVE PITCH AUTO MNVR. MODE TO FREE DRIFT TO PROTECT ISS FROM ORBITER PLUME LOADS AND CONTAMINATION
	ISS PHOTOGRAPHIC SURVEY OPPORTUNITY FROM U.S. LAB WINDOW
	RESUME ATTITUDE HOLD AS ORBITER RETURNS TO R-BAR ATTITUDE AND PILOT BACK TO NOMINAL APPROACH PROFILE
4	TORVA (TWICE) ORBITAL RATE R-BAR TO W-BAR APPROACH

### Space Shuttle Rendezvous Maneuvers

**OMS-1 (Orbit insertion)**- Rarely used ascent burn.

**OMS-2 (Orbit insertion)**- Typically used to circularize the initial orbit following ascent, completing orbital insertion. For ground-up rendezvous flights, also considered a rendezvous phasing burn.

**NC (Rendezvous phasing)** Performed to hit a range relative to the target at a future time.

**NH (Rendezvous height adjust)** Performed to hit a delta height relative to the target at a future time.

**NPC (Rendezvous plane change)** Performed to remove planar errors relative to the target at a future time.

**NCC (Rendezvous corrective combination)** First on-board targeted burn in the rendezvous sequence. Using star tracker data, it is performed to remove phasing and height errors relative to the target at Ti.

**Ti (Rendezvous terminal intercept)** Second on-board targeted burn in the rendezvous sequence. Using primarily rendezvous radar data, it places the orbiter on a trajectory to intercept the target in one orbit.

**MC-1, MC-2, MC-3, MC-4 (Rendezvous midcourse burns)**- These on-board targeted burns use star tracker and rendezvous radar data to correct the post-Ti trajectory in preparation for the final, manual proximity operations phase.



He will slow Discovery's approach and fly to a point about 600 feet directly below the station, and if required, wait for the proper lighting conditions. The rendezvous is designed to optimize lighting for inspection imagery as well as crew visibility for critical rendezvous events.

**Approach Profile**

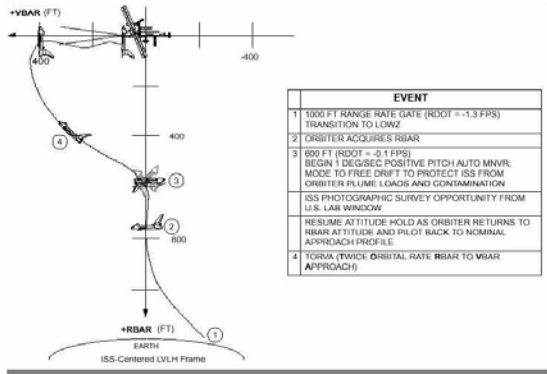

On verbal cue from Pilot Mark Kelly to alert the station crew, Lindsey will command Discovery to begin a nose-forward, three-quarter of a degree per second rotational back flip. At RPM start, the ISS crew will begin of series of photographs for inspection. The sequence of photography mapping provides optimization of the lighting conditions.

Both the 400 and 800 mm digital camera lenses will be used to photograph the required surfaces of the orbiter. The 400 mm lens provides up to 3 inch resolution and the 800 can provide up to 1 inch resolution as well as detect gap filler protrusions of greater than .25 inch. The imagery includes the upper surfaces of the shuttle as well as Discovery's belly, nose landing gear door seals, the main landing gear door seals and the elevon cove with 1 inch analytical resolution. Since the STS-114 mission, additional zones were added for the 800 mm lens to focus on the gap fillers on Discovery's belly when the orbiter is at 145 and 230 degree angles during the flip. There should be enough time for two sets of pictures.

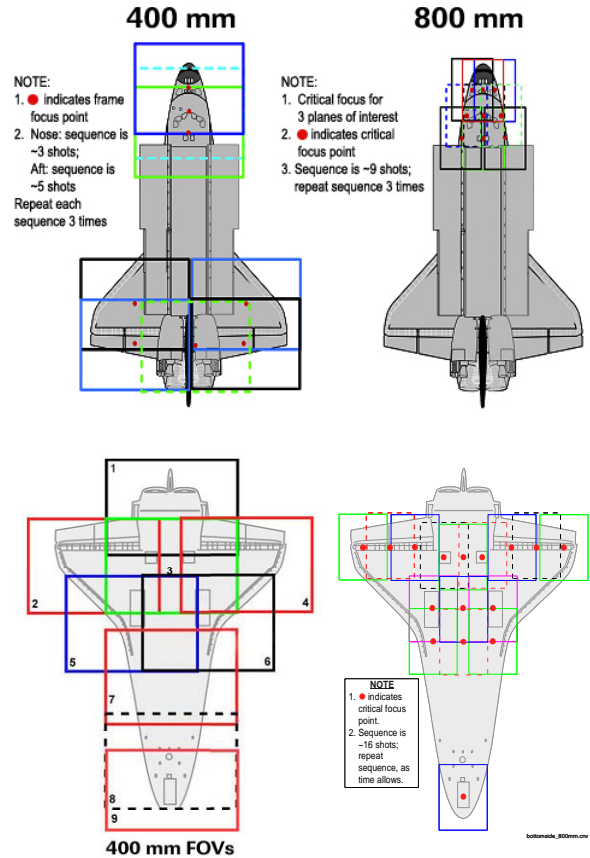

When Discovery completes its rotation, it will return to an orientation with its payload bay facing the station.

Lindsey will then move Discovery to a position about 400 feet in front of the station along the V-Bar, or the velocity vector, the direction of travel for both spacecraft. Kelly will provide Lindsey with navigation information as he slowly inches the shuttle toward the docking port at the forward end of the station's Destiny Laboratory.

Mission specialists Lisa Nowak and Stephanie Wilson also will play key roles in the rendezvous. They will operate laptop computers processing the navigational data, the laser range systems and Discovery's docking mechanism.

Using a view from a camera mounted in the center of Discovery's docking mechanism as a key alignment aid, Lindsey will precisely align the docking ports of the two spacecraft. He will fly to a point where the docking mechanisms are 30 feet apart and pause to check the alignment.

For Discovery's docking, Lindsey will maintain the shuttle's speed relative to the station at about one-tenth of a foot per second (while both Discovery and the station are traveling at about 17,500 mph), and keep the docking mechanisms aligned to within a tolerance of three inches. When Discovery makes contact with the station, preliminary latches will automatically attach the two spacecraft. Immediately after Discovery docks, the shuttle's steering jets will be deactivated to reduce the forces acting at the docking interface. Shock-absorber-like springs in the docking mechanism will dampen any relative motion between the shuttle and the station.

Once that motion between the spacecraft has been stopped, Wilson will secure the docking mechanism, sending commands for Discovery's docking ring to retract and to close a final set of latches between the two vehicles.

## **UNDOCKING, SEPARATION AND DEPARTURE**

Additional inspections of Discovery's heat shield are scheduled on flight day 10, the day before undocking, and flight day 11 immediately following undocking. Therefore, the orbiter will undock with the shuttle robotic arm and OBBS deployed. The OBSS will then

be stowed in Discovery's payload bay after the inspections are completed.

Once Discovery is ready to undock, Wilson will send a command to release the docking mechanism. At initial separation of the spacecraft, springs in the docking mechanism will push the shuttle away from the station. Discovery's steering jets will be shut off to avoid any inadvertent firings during the initial separation.

Once Discovery is about two feet from the station, with the docking devices clear of one another, Kelly will turn the steering jets back on and fire them to very slowly move away. From the aft flight deck, Kelly will manually control Discovery within a tight corridor as the orbiter separates from the station, essentially the reverse of the task performed by Lindsey just before Discovery docked.

Discovery will continue away to a distance of about 450 feet, where Kelly will initiate the first of two separation burns to fly the shuttle above the station. A full flyaround of the station is not planned to conserve time for further inspections of Discovery's heat shield. Once directly above the station, Kelly will fire Discovery's jets to leave the station area. Discovery will station keep at a distance of 40 nautical miles from ISS until the late inspection imagery is reviewed and the Mission Management Team clears the orbiter for landing. This position allows Discovery the opportunity to redock to the station if needed.

# SPACEWALKS

The STS-121 and Expedition 13 crews will work together to accomplish two spacewalks. They will focus on shuttle thermal protection system repair techniques and space station assembly and repair tasks.

A third spacewalk also will be conducted if mission managers determine the shuttle has enough consumables for an extra day for the mission. The third spacewalk would include tests of techniques for inspecting and repairing the orbiter's heat shield, the reinforced carbon-carbon (RCC) segments that protect the orbiter's nose cone and wing leading edges.

Each of the spacewalks by Piers Sellers and Mike Fossum will last 6½ hours. They will be conducted from the station's Quest airlock on flight days 5 and 7. The third spacewalk would be on flight day 9. They would be the 20th, 21st and 22nd Quest-based EVAs in support of space station assembly.

These will be the first spacewalks for Fossum. Sellers conducted three previous spacewalks on the STS-112 shuttle mission to station in October 2002, during which he helped install the starboard one (S1) truss segment.

Sellers will be designated EV1 and will wear the spacesuit with red stripes. Fossum will be designated EV2 and will wear no stripes on his spacesuit. Discovery Pilot Mark Kelly will be the intravehicular activity (IVA) crew member, offering advice and coordinating spacewalk activities from inside the complex.

Mission Specialists Lisa Nowak and Stephanie Wilson will maneuver their crewmates and hardware during the three spacewalks using the shuttle arm on the first and the station arm for the second and third spacewalks.

Expedition 13 crew members Jeffrey Williams and Thomas Reiter will help with the spacewalks. During preparations for the first spacewalk, Williams will join Kelly and Wilson in the Quest Airlock to help with spacewalk preparations. Reiter will assist with preparations for the third spacewalk.

Before each spacewalk, Sellers and Fossum will prepare by exercising on the station's bicycle ergometer. Designed to purge nitrogen from the blood, the procedure involves breathing pure oxygen while exercising vigorously. It prevents the spacewalkers from getting painful decompression sickness, or the bends, during the spacewalk.

## EVA 1

During the first spacewalk, the crew members will test the 50-foot robotic arm boom extension, usually used for remote shuttle thermal protection system (TPS) inspections, as a potential work platform for hard-to-reach repair sites on the bottom of the orbiter for detailed test objective (DTO) 849. They will also begin maintenance of the station's mobile transporter (MT) by safing or replacing a cable cutter and routing a cable on the MT to allow it to be moved before the second spacewalk.

The cable cutter, called an interface umbilical assembly (IUA), is on the top, or zenith side of the MT. A duplicate device on the Earth-facing, or nadir side, of the MT inadvertently cut the nadir cable in December 2005.

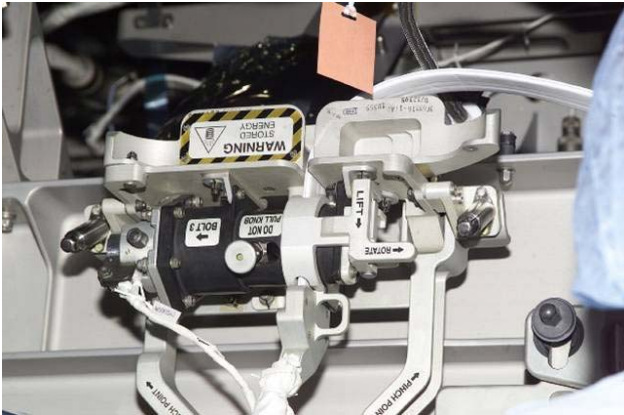

**Engineering photo of the IUA with the TUS cable routed through mechanism before launch and installation on ISS.**

The crew will first work on keeping the zenith IUA from activating in the future by either installing a device to block the cutter from the cable or remove the IUA and replace it with a new unit launched on Discovery. The Expedition 12 crew had tried to safe the zenith IUA during a spacewalk in March by installing a safing bolt, but the bolt could not be inserted. To prevent the cable from being inadvertently cut, that crew removed it from the IUA until the STS-121 crew could work on it. Sellers and Fossum will re-route the Trailing Umbilical System (TUS) cable through the IUA, once it is configured safely, to allow the MT to be moved from worksite 4 (WS4) to worksite 5 (WS5 on the station's truss) in advance of EVA 2.

The next objective of the spacewalk, is to test the new robotic boom as an orbiter tile inspection or repair work platform.



**Astronaut Piers J. Sellers, wearing a training version of the extravehicular mobility unit spacesuit, participates in a simulation. He is anchored on the end of the training version of the space shuttle remote manipulator system (RMS) robotic arm in the Space Vehicle Mockup Facility at Johnson Space Center. Lora Bailey (right), manager, JSC engineering tile repair, assisted Sellers. Astronaut Michael E. Fossum (center), mission specialist, also participated in the test.**

For the test, first Sellers and then both crew members, will work on the end of the boom. They will simulate repair-related movements in at least three different OBSS positions. Sensors installed on the OBSS and imagery from various cameras will provide post-flight information to engineers that will help them evaluate the stability of the boom.

Much of the test will be dedicated to setting up tools and the OBSS for the movements and then reconfiguring at the end. The movements of the spacewalkers for the tests in the three arm positions are scheduled to take about 30 minutes each. The spacewalkers will provide comments about each movement, while the sensors in the load cell record quantitative data for review following the mission.

After leaving the Quest airlock, Sellers and Fossum will first safe the zenith IUA as described above. Then they will move to the pressurized mating adapter (PMA) 1 to retrieve an articulating portable foot restraint (APFR) with a tool stanchion (TS). Next they will work their way down to Discovery's payload bay, hand-over-hand to setup for the test. Once in the payload bay, Sellers will temporarily place the APFR/TS on the integrated cargo carrier (ICC) and Fossum will configure it.

Sellers will then continue set up by deploying a sensor, called a load cell or instrumented worksite interface fixture (IWIF), which he will install later on the OBSS. Commander Steve Lindsey will use a laptop computer inside Discovery, with an RF antenna installed, to activate the sensor.

Nowak and Wilson will then move the shuttle's robotic arm so that the end of the OBSS/SRMS hovers above the starboard sill of the payload bay. There, Sellers will install several safety tethers onto the OBSS. Nowak and Wilson will then move the tip of the OBSS to just above the starboard sill of the payload bay.

Sellers will install the activated load cell and a portable foot restraint attachment device (PAD). Since this will be the first time that crew members interact directly with the OBSS,

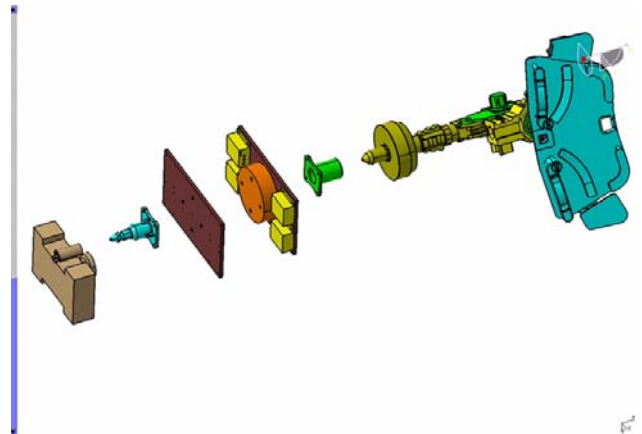

**Engineering model of the Articulating Portable Foot Restraint (APFR) and load cell configuration.**

Fossum will be on hand to physically stabilize the OBSS any time Sellers is performing setup and cleanup activities with it. Next, Sellers and Fossum will work together to move the APFR/TS onto the top of the load cell now on the tip of the OBSS. Sellers will extend the TS and ingress the APFR.

With setup complete, Nowak and Wilson will maneuver the robotic boom into the first test position, with Sellers riding at the end of the OBSS. Fossum will stay in the payload bay and take digital photos during the first test.

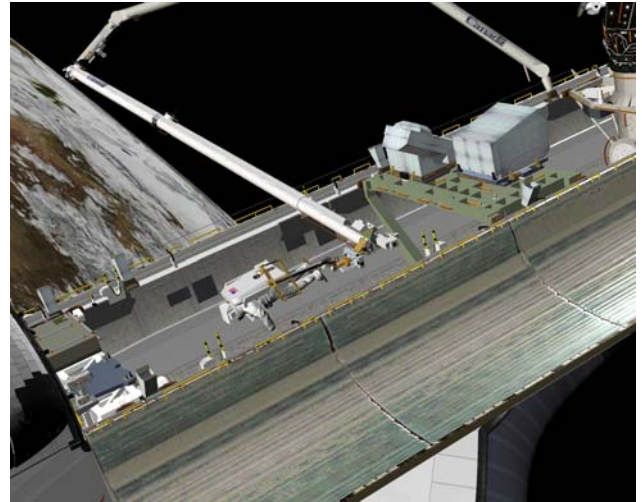

**Graphics show the position where Sellers and later Fossum can climb on to the robotic arm.**

For the first position, the end of the boom is about 14 feet from the payload bay, directly above the position where Sellers got on the boom. Once the boom is in place, Sellers will perform several movements to simulate real inspection or repair actions. The positions will simulate movement of a crew member on the tip of the boom during translation to, and while inspecting a potential damage site on the bottom of the orbiter. They include Sellers simulating taking photographs, laying back slightly to retrieve a tool behind him, reaching

for equipment in front of him, and making positional changes to the APFR and TS.

Due to the addition of the zenith IUA tasks to this EVA, time for the OBSS tests could be reduced. If the IUA task is completed faster than estimated, the arm will be moved into a second boom position for the tests. If there is not enough time, the arm will be moved directly to the payload bay sill for Fossum to attach to the boom and move directly into the third evaluation position.

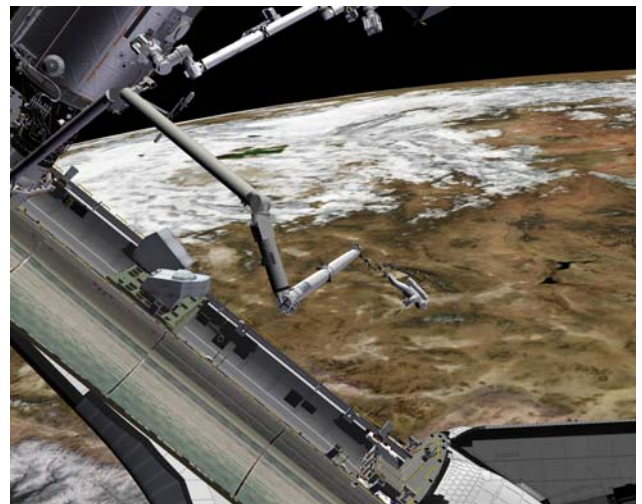
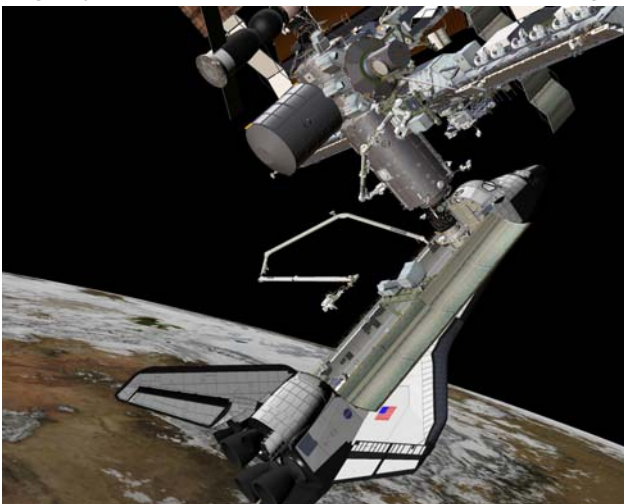

**Graphics show the first position of the robotic arm for the test.**

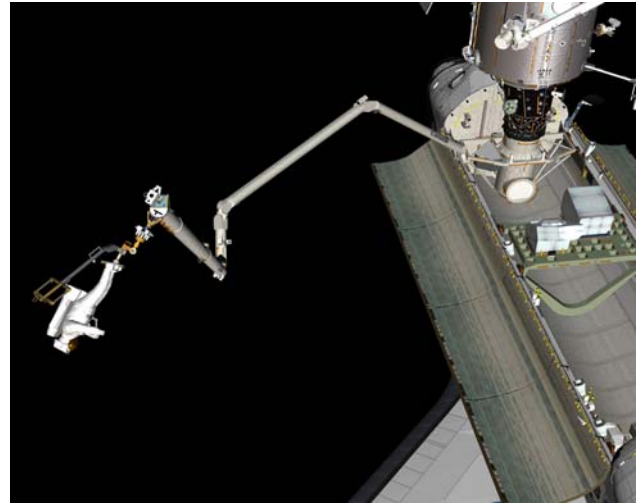
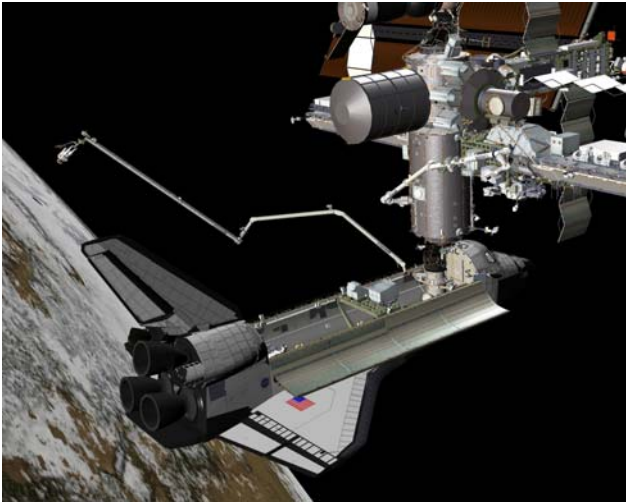

**Graphics show the second position of the robotic arm for the test.**

The second position, where Sellers will perform additional movements, has the end of the OBSS extending about 27 feet to the port and aft of Discovery's payload bay. This position has the SRMS joints in a slightly "weaker" configuration which should result in larger OBSS deflections. Sellers will go through three sets of movements similar to the movements at the first test position. Fossum will reposition himself in the payload bay to watch and document the second round of tests.

Once the tests in the first position are complete, and if time allows, Nowak and Wilson will move the OBSS back to above the sill of the payload bay where Fossum will be waiting. There, Sellers will move off the APFR so Fossum can get on. Then Sellers will hang onto the TS and both will tether themselves in place. Nowak and Wilson will then move the OBSS into an intermediate position and then the third test position.

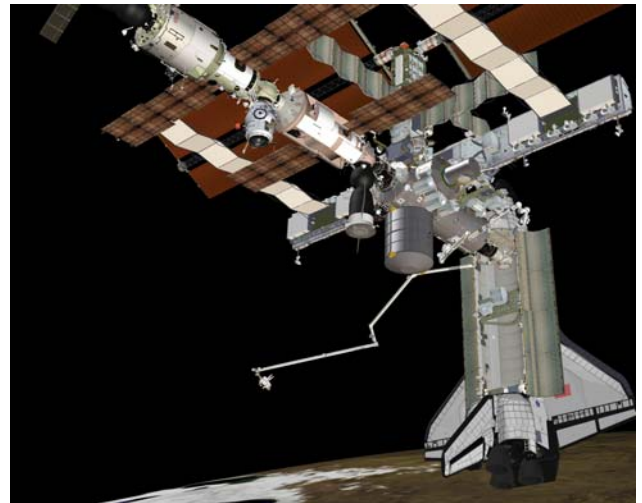
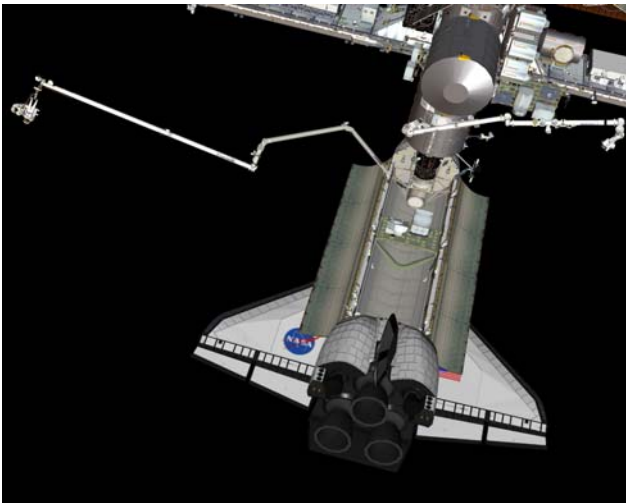

**Graphics show the intermediate position of the robotic arm for the test.**

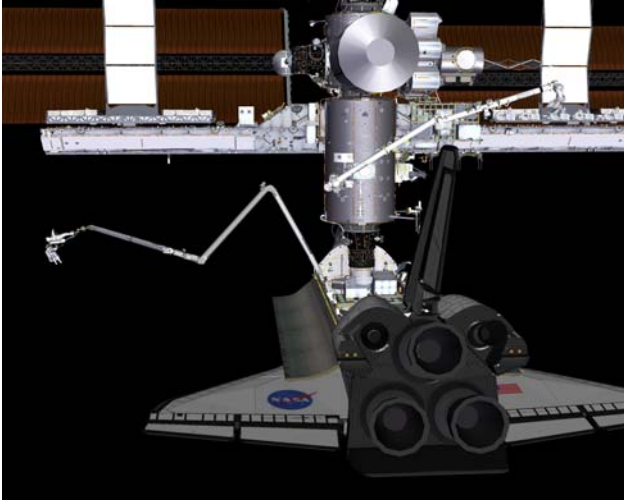

**Graphics show the third position of the robotic arm for the test.**

In the third position the end of the OBSS is 16 feet in front of the station's P1 truss segment. The configuration of the SRMS joints provides a similar "weakness" to those of position 2. The main difference is that both crew members are now on the tip of the OBSS. During the position 3 evaluations, Fossum will make gestures similar to what Sellers did at the first two positions with Sellers now also on the boom. Both crew members will move simultaneously for some of the test.

Once the movements at the third test position are complete, Nowak and Wilson will move the end of the OBSS with both Fossum and Sellers toward the station's P1 truss segment for the final set of tests. At this test position Fossum will simulate repair movements on the P1 truss structure. The P1 truss was selected to represent a TPS damage location somewhere on the orbiter that would need repair. This specific location was chosen because of the SRMS joints that are necessary to reach it. Once again, the joints provide a "weak" configuration that allows for larger OBSS tip deflections. The data resulting from using a "weaker" configuration

is expected to provide the best information in order to gauge the capability of performing a real repair from the OBSS. The movements performed by Fossum will simulate applying tile repair material with an emittance wash applicator (EWA), drilling on an RCC panel, and using a spatula with repair material on an RCC panel.

Once the testing is done in the final OBSS position, Nowak and Wilson will move the arm so the spacewalkers can egress onto Discovery's payload bay sill. With Fossum's assistance, Sellers will cleanup the end of the OBSS by removing the APFR/TS, load cell, PAD and safety tethers. The equipment will be taken back to the airlock with the spacewalkers. Once the OBSS is reconfigured, the arm will be moved higher above the payload bay out of the way.

With the testing complete, Sellers and Fossum will work their way, hand-over-hand, back up to the space station. They will replace the APFR/TS they used onto the PMA 1 and reenter the Quest airlock.



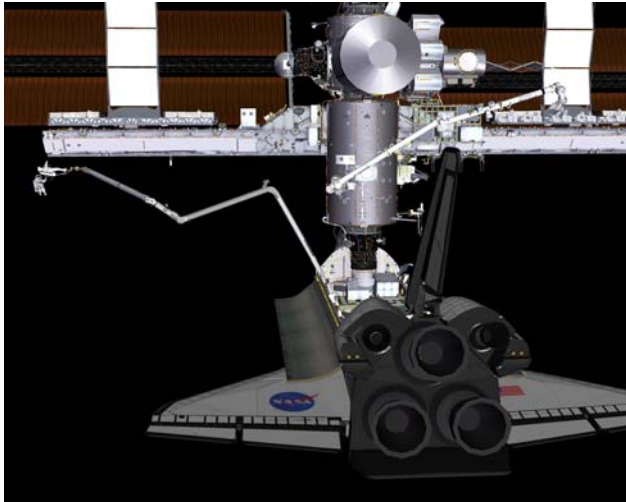

Graphics show the final position of the robotic arm for the test.

## EVA 2

The second EVA will consist of installing the thermal control system's spare pump module and replacing the nadir Trailing Umbilical System – Reel Assembly (TUS-RA). The TUS provides power, data and video to the MT. During EVA 1, the crew re-routed the zenith TUS cable thru the zenith IUA to allow the TUS to be moved from position WS4 to WS5. Before EVA 2, the MT must be moved from WS4 to WS5 because its current position makes it difficult for the crew to change out the nadir TUS-RA.

At the start of EVA 2, both crew members will translate down to the payload bay and prepare the pump module for transfer. The first activity will be for Fossum and Sellers to take the fixed grapple bar (FGB) from the underside of the ICC and install it onto the pump module. The FGB will allow Nowak and Wilson to latch onto the pump module with the station's robotic arm and move it to the worksite at the external stowage platform 2 (ESP2) for installation.

Once the FGB is installed, the crew will release the pump module from the ICC and lift it up to present it to the robotic arm.

During the arm's maneuver, Sellers and Fossum will begin preparation for removing and replacing the TUS-RA. First, they will prepare the payload bay by relocating some APFRs and opening the TUS multi-layer insulation (MLI) cover. Then, they will translate to the starboard zero (S0) truss segment, located above the Destiny Lab. Fossum will prepare the old TUS-RA for removal by releasing electrical connectors and bolts, while Sellers changes out the nadir IUA in preparation for routing the new TUS cable.

Once complete, they will both translate to ESP2 to install the pump module. Nowak and Wilson will present the pump module with the robotic arm. Once Sellers and Fossum have a hold, the arm will release it and move away so the pump module can be set on ESP2 and bolted in place.

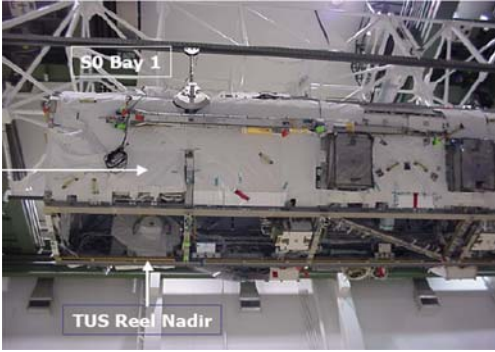

**Engineering imagery of the S0 truss segment before launch shows the original TUS-RA installed inside.**

Next, Fossum will configure the robotic arm with an APFR and, along with Sellers, release and remove the old TUS from S0. Fossum, now mounted on the robotic arm, will be maneuvered down to the payload bay. Because this maneuver will take some time, Sellers will translate to the payload bay and finish preparation tasks for removal of the new TUS-RA. Once both are ready, Sellers will get into an APFR on the ICC and Fossum will hand Sellers the old TUS-RA. Fossum will then maneuver to the new TUS-RA, remove it from its launch location and return to Sellers to swap the 330-pound TUS-RAs.

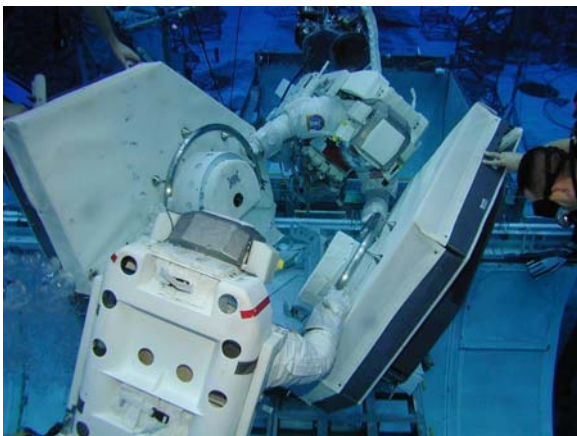

**Sellers and Fossum practice handing over the TUS-RA during a simulated spacewalk in the Neutral Buoyancy Lab.**

Fossum will hand Sellers the new TUS-RA—Sellers will have a one in each hand—and then Sellers will hand Fossum the old TUS-RA. Fossum will put the old reel assembly on the carrier and retrieve the new one from Sellers. Fossum, who is still on the end of the robotic arm, will take the new TUS-RA and begin to maneuver up to S0 to install it. Sellers will complete installation of the old TUS onto its stowage location with the flight support equipment, and then translate back up to S0. Together they will install the new TUS-RA into S0 and route the new cable to the nadir IUA. With the EVA complete, there will be both a zenith and nadir TUS, assuring redundancy for operation of the Mobile Transporter.



**Sellers and Fossum practice replacing the TUS during a simulated spacewalk in the Neutral Buoyancy Lab.**

### **EVA 3 (TENTATIVE)**

Once mission managers determine the shuttle consumables can support an extra day for the mission, the third spacewalk will be performed. It will include tasks that aim to test techniques for repairing and inspecting the RCC segments that protect the orbiter’s nose cone and wing leading edges.

After leaving Quest, Sellers and Fossum will setup tools on the end of the station’s robotic

arm, Canadarm2. Sellers will install an APFR on the end of Canadarm2. Fossum will hand him supplies and tools to attach, including a CRM bag and an Infrared camera.

Sellers will use the infrared (IR) camera as part of DTO 851 to take about 20 seconds of IR video of RCC panels on Discovery's wing leading edge while being transported on the end of Canadarm2 to Discovery's payload bay.

The FLIR Systems ThermaCAM S60 Infrared Camera is being assessed as a way to inspect RCC for damage on-orbit. Depending on how far away the crew member is, the camera's field of view can cover 52 inches, or about two RCC panels, to 83 feet, the entire wing leading edge at a time. The camera can record temperature variances from minus 400-degrees Celsius to 1,200-degrees Celsius. The video is recorded at a 0.6 Hz frame rate and is saved on internal memory and then transferred to a memory card.

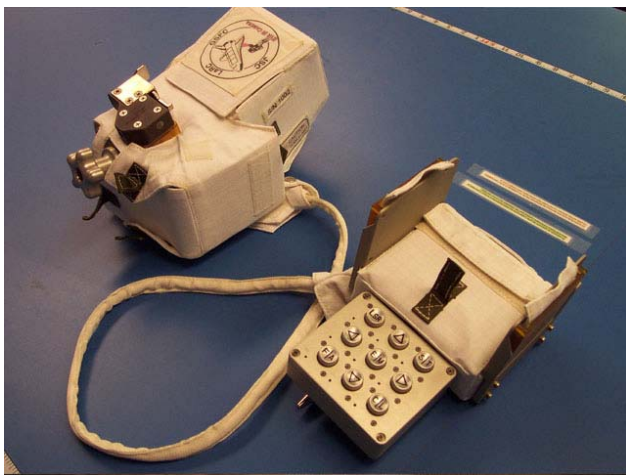

**Infrared camera simulation hardware**

Meanwhile, Fossum will travel hand-over-hand to the cargo bay and begin setting up the worksite. The two will work side-by-side to test repair techniques on a pallet of pre-damaged RCC samples. The pallet includes twelve RCC samples. Eight have various sized

cracks and/or gouges, two are blank slates or "palettes" to be used during repairs of the other samples, and two are pre-damaged samples to be imaged with the IR camera. There are more samples for the crew members to work with than what is required or expected to be completed. The pallet is located in the aft portion of Discovery's cargo bay.

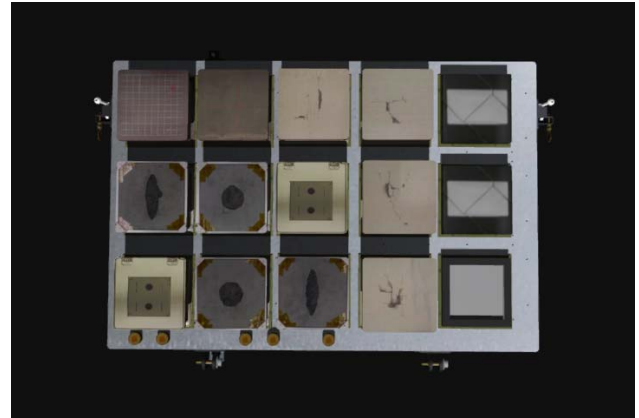

**Artist's rendering shows the configuration of the samples in the DTO pallet.**

Fossum will setup another APFR to position himself next to the pallet and open the pallet's lid. Once in the cargo bay, Sellers will get off the robotic arm to attach the CRM bag to the inside of the pallet's lid and then get back on the arm to begin the repair work.

The RCC crack repair tasks for DTO 848 involve using a pre-ceramic polymer sealant impregnated with carbon-silicon carbide powder, together known as NOAX (short for non-oxide adhesive experimental). The NOAX material is temperature sensitive and the ideal condition for the repairs is when the samples are between 100 and 35 degrees Fahrenheit, with the temperature decreasing.

Therefore the crew members are scheduled to work on the crack repairs with the NOAX material during night portions of their orbit, beginning the repair just after orbital sunset.

The choreography of the spacewalk is planned to optimize two to three day/night passes for crack repair tasks. There is about 2½ hours allotted for the repair technique testing. When the crew leaves the airlock, Mission Control Houston will begin assessing the lighting conditions and use temperature readings of the RCC sample taken by the crew to determine how to proceed with the tasks.

Due to the intricacies of each DTO's requirements, the flight control team will closely monitor the spacewalk to prioritize the order of the tasks real-time. DTO 848 has an overall higher priority than DTO 851 and within each DTO tasks are prioritized individually.

EVA 3 DTO priorities:

1. Two of four RCC crack repair impact damage samples (DTO 848)
2. IR camera wing leading edge imaging (DTO 851)
3. IR camera specific RCC damaged sample imaging (DTO 851)
4. The remaining two RCC crack repair impact damage samples (DTO 848)
5. All remaining RCC repair samples (DTO 848)

Once setup for the spacewalk is complete, if the temperature readings are acceptable, the crew will begin repairing a cracked or gouged RCC sample.

For the tests, Fossum will assist Sellers as he uses a space-hardened caulk gun to dispense the NOAX material. Using one of three manual caulk guns in the crack repair kit, he will dispense the material directly onto the sample. He will then use one of many spatulas, similar

to a putty knife, to work the crack repair material into the pre-damaged RCC sample mounted in the DTO pallet. Additional layers will then be added to the repair by first extruding the material onto the nearby RCC palettes. He will then use the spatula to manipulate the material onto the sample being repaired.



**Engineering models show the various RCC repair tools the crew will use during the test.**

NASA materials experts have estimated that cracks or coating damage as small as 2 inches long and .02 of an inch wide in some locations on the shuttle's wing leading edge could result in catastrophic damage to that wing. The crack filling method is designed to fix the type of damage most likely to be caused by small pieces of foam coming off the redesigned external tank. NOAX can be used at any RCC location, and does not require any physical modification of the RCC before affecting a repair. It is expected to repair cracks or coating losses up to four inches long, but cannot be used to repair large holes.

The spacewalk crew members have had extensive training and experience with the RCC repair methods and the behavior of NOAX at vacuum as well as at various thermal extremes. Since the behavior and working life of NOAX is

temperature dependent, the crew will be in the best posture to determine if an RCC repair is “complete” or if additional work needs to be performed to the repair sample. “Completion” of an RCC repair sample will be determined by the spacewalkers, rather than the ground control team.

Once the first repair is complete, the crew members will move on to working with the next cracked sample, using the same techniques.

Sellers and Fossum will continue repairing the remaining cracked samples with the NOAX material as time permits. If at least the two highest priority RCC impact damage samples have been repaired, there is an additional task for DTO 851 for the crew to complete. It involves taking about 60 seconds of video with the IR camera of two damaged RCC samples on the pallet. Sellers will use the IR camera to record a temperature gradient throughout each RCC sample itself. As with the actual RCC repair tasks, it is preferred that the temperature

is dropping. Therefore, the best imaging will occur by Sellers starting the imaging during direct sunlight and then about 10 seconds later he will shade the samples to provide the desired temperature gradient.

About five hours into the spacewalk, the crew members to begin cleaning up the worksite and preparing to end the spacewalk. Both crew members will inspect each other’s suits for repair material residue. Sellers will get off the robotic arm so Fossum can ride it back to the Quest Airlock. Before getting on the arm Fossum will gather the repair material bag and other tools for Sellers to attach to the robotic arm. Both crew members will close the sample pallet lid. Then while being transported back to Quest, Fossum will use the IR camera to take about 20 seconds of video of Discovery’s wing leading edges again. Meanwhile, Sellers will move hand-over-hand back to Quest. Once at the airlock, Fossum will get off the robotic arm and stow the APFR. Both crew members will then enter the airlock.



## PAYLOAD OVERVIEW

Space Shuttle Discovery will carry a variety of payloads. The flight will carry 28,120 pounds of equipment and supplies in its cargo bay to the International Space Station. Additional items will be carried on the space shuttle mid-deck, which include supplies, food, water and clothing for the crew.

The cargo bay is 60 feet long and 15 feet in diameter, and can carry the cargo equivalent to the size of a school bus. Under the Space Flight Operations Contract with United Space Alliance, Boeing performs the form, fit and function of any cargo that goes into the payload bay. The addition of the 50-foot boom and its suite of sensors called the orbiter boom sensor system are considered to be part of the orbiter and are not considered part of the payload weight listed above. The OBSS is used to conduct inspections of the space shuttle's thermal protection system (TPS).

### MULTI-PURPOSE LOGISTICS MODULE (MPLM) "LEONARDO"

The Leonardo MPLM acts as a moving van for the International Space Station, ferrying scientific experiments and crew supplies to and from the orbiting laboratory.

On this mission, Leonardo will be mounted in the space shuttle's payload bay for launch and remain there until after docking. Once the shuttle is docked to the station, the ISS robotic arm will be used to remove Leonardo from the payload bay and berth it to a Boeing-built common berthing mechanism on the nadir side of the station's Unity Module. During its berthed period to the station, individual components as well as racks will be transferred to the station.

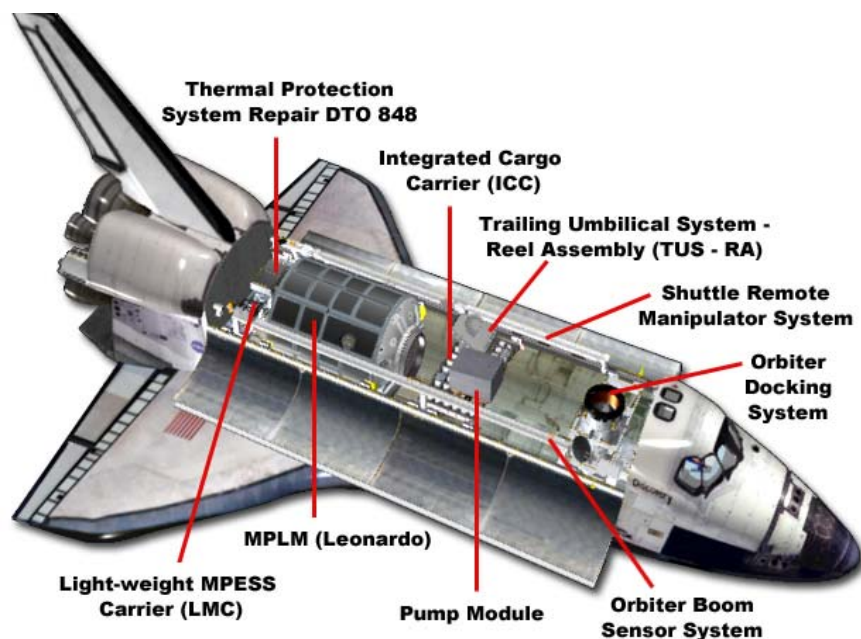

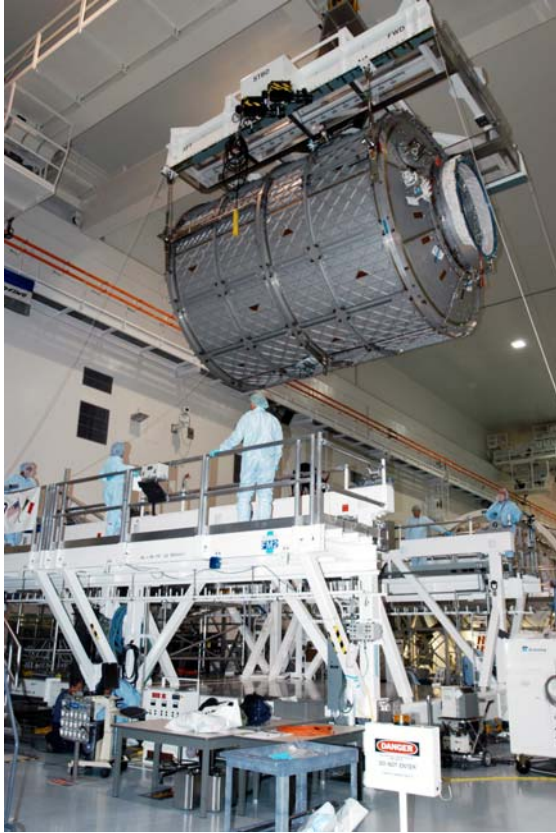

**Workers stand by in the Space Station Processing Facility at NASA's Kennedy Space Center, as the Multi-Purpose Logistics Module Leonardo is lowered toward the Cargo Element Work Stand.**

Leonardo will carry five resupply stowage platforms (RSPs), three resupply stowage racks (RSRs), one EXPRESS (EXpedite the PROcessing of Experiments to the Space Station) transportation rack (ETR), the European modular cultivation system (EMCS), an oxygen generation system (OGS) rack and the MELFI. The OGS, RSRs and ETR are U.S.-built while the MELFI is provided to NASA by the European Space Agency (ESA) as part of the Columbus orbital facility launch barter agreement.

Utility Logistics Flight (ULF) 1.1 is primarily an ISS crew augmentation mission (a third crew

member will arrive on this flight), with the MPLM ferrying more than 5,000 pounds of cargo, a majority of which is food, clothing and crew consumables. The MPLM will have 153 cargo transfer bags (can hold about 1.6 cubic feet per each rectangular-shaped suitcase) to bring supplies into the station. The CTBs are installed in lockers in RSRs in the MPLM and are removed individually by the crew and then stored in the station.

The MPLM will carry two new research facilities; MELFI and EMCS. MELFI is a dedicated rack sized facility while EMCS will be located within EXPRESS Rack No. 2. These two facilities will be installed in the Boeing-built Destiny laboratory.

The EXPRESS rack is a standardized payload rack system that transports, stores and supports experiments aboard the ISS. EXPRESS stands for EXpedite the PROcessing of Experiments to the space station, reflecting the fact this system was developed specifically to maximize the station's research capabilities. With its standardized hardware interfaces and streamlined approach, the EXPRESS rack enables quick, simple integration of multiple payloads aboard the ISS.

The MELFI, which weighs 1,617 pounds, will provide current and future ISS crews with a critical lab freezer capability for maintaining scientific samples and experiments and will ultimately provide greater capability for utilization, life sciences and research.

The EMCS, a ½ EXPRESS rack that weighs 655 pounds, is a large incubator that provides control over atmosphere, lighting and humidity of growth chambers. The first planned experiment will use the chamber to study plant growth.



The MPLM will also transport the 1,465 pound OGS rack that uses water to generate breathable oxygen for crew members. The life-support system is considered a test initiative for future long-duration missions to the moon and Mars. The system - which was designed and tested by engineers from Marshall Space Flight Center and from Hamilton Sundstrand Space Systems International in Windsor Locks, Conn. - will replace oxygen lost during experiments and airlock depressurization and can provide up to 20 pounds of oxygen daily - enough to support six station crew members - although it is initially planned to produce about 12 pounds daily.

The MPLM will also carry a new cycle ergometer with vibration isolation and stabilization (CEVIS). CEVIS will give expedition crews on station better aerobic and cardiovascular conditioning through cycling activities. In addition, the MPLM will carry a common cabin air assembly heat exchanger (CCAA HX) used to cool cabin air and maintain a good cabin temperature; it will replace the one currently on orbit.

Used equipment and a small amount of trash will be transferred to Leonardo from the ISS for return to Earth. The Leonardo logistics module will then be detached from the station and positioned back into the shuttle's cargo bay for the trip home. When in the cargo bay, Leonardo is independent of the shuttle cabin, and there is no passageway for shuttle crew members to travel from the shuttle cabin to the module. The total weight of Leonardo for STS-121 with the cargo, platforms and racks is just less than 21,000 pounds for launch and a little over 17,900 pounds for landing.



**The Canadarm2 grasps the Italian-built MPLM Raffaello to place it back in Discovery's cargo bay during STS-114. The Earth forms the background.**

### History/Background

Leonardo, built by the Italian Space Agency, is the first of three such pressurized modules that serve as the station's "moving vans," carrying laboratory racks filled with equipment, experiments and supplies to and from the ISS aboard the space shuttle.

Construction of the Leonardo module was the responsibility of Altec in Turin, Italy, which is a subsidiary of Alenia Aerospazio. Leonardo was delivered to Kennedy Space Center from Italy in August 1998 by a special Beluga cargo aircraft. The cylindrical module is about 6.4 meters (21 feet) long and 4.6 meters (15 feet) in diameter. It weighs about 9,500 pounds (almost 4.5 metric tons). It can carry up to 10 metric tons of cargo packed into 16 standard space station equipment racks.

Although built in Italy, Leonardo and two additional MPLMs are owned by the U.S. They were provided in exchange for Italian access to U.S. research time on the station. The unpiloted, reusable logistics module functions as a cargo carrier and a space station module when it is flown. To function as an attached

station module as well as cargo transport, Leonardo contains components that provide some life support, fire detection and suppression, electrical distribution and computer functions. Eventually, the modules might also carry refrigerator freezers for transporting experiment samples and food to and from the station.

Leonardo first flew to the space station aboard Discovery on STS-102/5A.1 in March 2001. It flew again aboard Discovery on STS-105/7A.1 in August 2001 and aboard Endeavour on STS-111/UF2 in June 2002. Aboard Discovery, STS-121 will be its fourth flight.

## **OXYGEN GENERATION SYSTEM (OGS)**

The MPLM will transport the 1,465-pound OGS rack to the International Space Station. The system uses water to generate breathable oxygen for six crew members. The system – which was designed and tested by engineers from NASA’s Marshall Space Flight Center in Huntsville, Ala., and from Hamilton Sundstrand Space Systems International in Windsor Locks, Conn. – also will replace small amounts of oxygen lost during experiments and airlock depressurization.

In January 2006, the OGS was shipped from the Marshall Space Flight Center to the Kennedy Space Center, Fla., where it was installed in the MPLM in preparation for its launch on board Discovery.

The oxygen generation system is one of two primary components in the station's regenerative environmental control and life support system. The other component, the water recovery system, is planned for shipment to Kennedy Space Center in early 2007, once testing and design modifications are complete.

Delivering this hardware to the space station is a major step toward achieving the full potential of the complex. Once complete, the regenerative life support system will sustain additional crew members who can conduct more scientific research. It also will provide experience in operating and sustaining a life support system similar to that necessary for future human spaceflight missions farther from Earth.

Once activated, the oxygen generation system will be capable of providing up to 20 pounds of oxygen daily. During normal operations, it will provide 12 pounds daily, enough to support six crew members. The system will tap into the space station's water supply and split the liquid into hydrogen and oxygen molecules. The hydrogen will be vented to space, and the oxygen will be vented into the space station atmosphere. The system is designed to operate with little monitoring.

The water recovery system provides clean water by recycling waste water and urine. The recycled water must meet purity standards before it is used to support crew, payload and spacewalk activities. The oxygen generation and water recovery systems will be packaged into three refrigerator-sized racks for installation in the station's Destiny lab module.

The oxygen generation and water recovery systems both represent a substantial leap from the technology used in earlier eras of space travel. The life support systems on the Mercury, Gemini and Apollo spacecraft in the 1960s were designed to be used once and discarded. Oxygen for breathing was provided from high-pressure or cryogenic storage tanks. Carbon dioxide was removed from the air by lithium hydroxide in replaceable canisters. Contaminants in the air were removed by replaceable filters and activated charcoal

integrated with the lithium hydroxide canisters. Water for the Mercury and Gemini missions was stored in tanks, while fuel cells on the Apollo spacecraft produced electricity and provided water as a byproduct. Urine and waste-water were collected and stored or vented overboard. Today, the station relies on a combination of expendable and regenerative life support technologies in Destiny and the Russian Zvezda Service Module.

As we continue to explore the solar system, advancing life-support technology will remain a focus. On future deep space missions, resupply of oxygen and water will not be possible, due to the distances involved. It will not be feasible to take along all the water and air needed, due to the volume and mass of consumables required for a voyage of months or years. Regenerative life support hardware which can generate and recycle the life sustaining elements required by human travelers is essential for long duration trips into space.

## **MINUS EIGHTY LABORATORY FREEZER FOR ISS (MELFI)**

The MELFI, which weighs 1,609 pounds, will also be flying to the space station on the STS-121 mission. It is a rack-size facility which will provide the space station with refrigerated volume for storage and fast freezing of life science and biological samples. It will also ensure the safe transportation of conditioned specimens to and from the station by flying in fully powered mode in the MPLM. MELFI was designed for an operational lifetime of 10 years, with each continuous mission lasting up to 24 months. MELFI has also been qualified for 15 launches.



**Technicians inspect the Minus Eighty Lab Freezer for ISS (MELFI) at NASA's Kennedy Space Center.**

ESA astronaut Thomas Reiter will be involved in commissioning activities when it arrives at the space station and will also use the facility for storage of samples from the physiology experiments CARD and Immuno. The samples can be stowed in four compartments (dewars), whose temperature can be independently controlled at different levels (-112, -15, 39° F). Each dewar is a cylindrical vacuum-insulated container, having an internal volume of about 75 liters, divided internally in four sectors. Each sector hosts one tray, which can be extracted without disturbing the samples in the other three. MELFI provides standard

accommodation hardware for the insertion of samples of different shapes and sizes.

The MELFI cooling system has been the subject of a very intense technology development program. In particular, the sophisticated cooling machine, which is able to provide the required temperatures while using very limited power (less than 1 kW in the worst case). It is mounted within a complex enclosure, called the cold box, in order to minimize any thermal loss and contamination of the cooling fluid. The cold box contains in addition two heat exchangers, consisting of a total of 10 km of piping.

The cooling machine is designed to be an orbital replacement unit. It can be dismantled from the cold box with the help of dedicated tools, in less than eight hours, allowing the preservation of specimen even in case of machine failures. In order to improve the reliability and availability of the freezer, the present launch configuration includes a spare electronic unit and a spare cooling machine. The cooling fluid is high-purity nitrogen. All the lines and components through which the nitrogen flows are double walled, with high vacuum and multi-layer insulation in between the two walls. This allows maintaining the selected temperature for up to eight hours even without power.

The present launch configuration of MELFI includes the MELFI On-Orbit Commissioning Experiment (MOOCE), also developed by ESA. This will be carried out few weeks after installation to monitor the thermal behavior of one of the compartments. MELFI will be immediately used to store samples processed in, e.g., the human research facility.

Upon arrival to the space station, MELFI will be transferred to the U.S. Destiny Laboratory and will be ready to start its service life.

MELFI was developed by the ESA in the frame of international barter agreements. Two flight units have been supplied to NASA and one the Japan Aerospace Exploration Agency (JAXA). In addition, ESA has delivered to NASA ground units for training and experiments preparation and will provide the necessary spares and sustaining engineering to maintain MELFI for up to 10 years of operations.

EADS- ASTRIUM (France) led the Industrial Team including L'Air Liquide (France), LINDE (Germany), Kayser-Threde (Germany) and ETEL (Switzerland).

## **EUROPEAN MODULAR CULTIVATION SYSTEM (EMCS)**

The EMCS, a ½ Express Rack that weighs 655 pounds, is a large incubator that provides control over atmosphere, lighting and humidity of growth chambers. The first planned experiment will use the chamber to study plant growth.

It is an ESA experiment facility dedicated to biological experiments, with several experiments already planned dealing primarily with the effects of gravity on plant cells, roots and physiology. These types of experiments will help to provide new knowledge about growth processes in plants and have the potential for making improvements in food production techniques on Earth and in space. This will hold benefits for astronauts on longer-term missions such as an expedition to Mars as part of ESA's Aurora program. Experiments with insects or amphibia and studies with cell and tissue cultures are foreseen in the EMCS as well. The ESA astronaut will be involved in the accommodation of the EMCS in an Express Rack in the Destiny.



**ESA astronaut Reinhold Ewald inserts an experiment container into the EMCS Engineering Model.**

The EMCS consists of a gas tight incubator where the humidity and composition of the air, temperature, light, water supply and a number of other parameters will be closely monitored and controlled. It contains two centrifuges, each one with space for four experiment containers. Each experiment container has an internal volume of 60 x 60 x 160 mm with a transparent cover. White light or infrared LED illumination is available for each single container. Video cameras are available for experiment observation. Each centrifuge can be programmed individually to provide from 0.001g up to 2g in weightlessness.

Video, data and command lines will allow experiment control by the station crew and from the ground.

During flight, equivalent ground control experiments may be performed inside dedicated experiment reference models, one located at the Norwegian User Support and Operations Center in Trondheim, Norway, the other at the NASA Ames Research Center in California. The flight unit also provides the potential for 1g control experiments on board the space station.

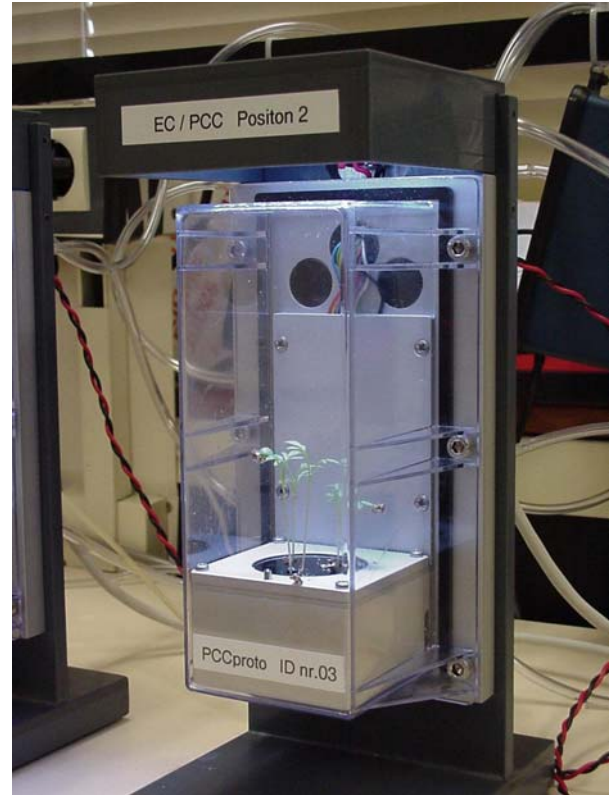

**Plant Cultivation Chamber inside experiment container as part of experiment reference model hardware.**

The first experiments to take place within the EMCS include molecular and physiological analyses of a type of cress (*Arabidopsis*), and the short- and long-term effects of weightlessness on the development of rotifers and nematodes.

The scientific utilization of the EMCS will be carried out in co-operation with the NASA Ames Research Center. EMCS is developed under ESA contract by an industrial team led by the company EADS Space Transportation (Friedrichshafen, Germany). Although it is provided as part of a barter agreement with the United States, European access is also possible.

## PERCUTANEOUS ELECTRICAL MUSCLE STIMULATOR (PEMS)

The PEMS will be flying to the space station on the STS-121 shuttle mission. It will be checked out by the ESA astronaut as part of his scheduled activities.

PEMS is a self-contained device, the purpose of which is to deliver electrical stimulation to non-thoracic muscle groups of the human test subject, thereby creating contractile responses from the muscles. Its main purpose is to support human neuromuscular research. The device can provide either single pulse or pulse trains with two selectable pulse widths and variable amplitudes.



**The Percutaneous Electrical Muscle Stimulator.**

PEMS is portable, and designed to be used in conjunction with other physiological instruments, in particular the Muscle Atrophy Research and Exercise System (MARES). PEMS will be checked out and commissioned in the U.S. laboratory. Eventually PEMS should be used together with the MARES in the European Columbus laboratory after it arrives at the space station.

The PEMS was developed by the Swiss company Syderal. This is a second generation of the PEMS device, the first generation PEMS having flown on the space shuttle in 1996.

## INTEGRATED CARGO CARRIER (ICC)

A second item carried in the payload bay is called the Integrated Cargo Carrier (ICC), which will be located immediately forward of the MPLM. The ICC is a cross-bay platform used to carry items in the payload bay.

This platform will contain orbital replacement units (ORU) for the space station and payload grapple bars. The ORU items include an external active thermal control system pump module for the station's cooling system and a trailing umbilical system reel assembly (TUS-RA).



## EXTERNAL ACTIVE THERMAL CONTROL SYSTEM (EATCS) PUMP MODULE

The EATCS is the space station cooling system that radiates the heat generated on the complex into space. The pump modules circulate liquid ammonia at a constant rate to a network of cold plates and heat exchangers located on the external trusses and U.S. segment modules, respectively. There are two pump modules on the station, one located on the S1 truss and the other on the P1 truss.

The pump module delivered on STS-121 will be transferred from the ICC and stowed on the External Stowage Platform 2 (ESP-2) during the second spacewalk. It is required for assembly operations scheduled on shuttle mission STS-116 or 12A.1 in station assembly terms.

## **TRAILING UMBILICAL SYSTEM – REEL ASSEMBLY (TUS-RA) AND INTERFACE UMBILICAL ASSEMBLY (IUA)**

The mobile transporter is a cart-like device that moves up and down rails along the International Space Station integrated truss serving as a mobile base for the Canadian robotic arm. Its power, video and data go through a set of redundant cables that are part TUS. The TUS reel assembly (TUS-RA) is basically a large spool much like a garden hose reel that pays out cable when the MT moves away and rolls it back up as the MT returns to the center of the truss. Each TUS is equipped with a blade cutter device that can remotely sever the cable in the event it becomes tangled so the MT can continue to operate using the other umbilical. The mobile transporter is used for assembly of large elements of the station. It must be locked down at various work sites before the robotic arm can move anything. When it is locked down, power is provided to the Canadian-built arm and several components on top of the mobile base station and it is much more structurally secure. NASA flight rules require both TUS cables to be intact before translating anything attached to the transporter.

On Dec. 16, the TUS cable No. 1 was cut by the electro-mechanical TUS disconnect actuator (TDA), which is located inside a device called the interface umbilical assembly (IUA). Engineers believe there was a hardware failure of the spring actuated TDA, but cannot confirm it until it is returned for further analysis. Once

the actuator deploys with about 960 pounds of force, it cannot be retracted and the IUA must be replaced since the cable path is blocked. The TUS-RA has to be replaced too whenever the cable is cut since it is too complex to repair on orbit. The two IUAs, which are mounted on the mobile transporter, measure 20 by 18 inches and weigh about 28 pounds each. The replacement IUA will be carried in the mid-deck of the space shuttle while the TUS-RA will be carried in the shuttle's payload bay. The TUS-RA is located on the starboard edge of the S0 truss and measures 5' x 5' x 2.5' and weighs 334 pounds. The TUS-RA cable is about .25 inches thick and 1.6 inches wide and has about 158 feet of usable length on the reel assembly.

If the mobile transporter ever gets stuck between stations, procedures have always allowed for an astronaut to remove a hung cable using a spacewalk; cutting the cable was always a last option. The cable cutter design dates back to the Space Station Freedom days when it was envisioned that large propulsive elements, with potentially explosive hydrazine, were expected to be translated on the mobile transporter. In those days, there was not enough time to complete a spacewalk before the situation would have become dangerous (hydrazine becomes explosive once it freezes), so the cable cutter was placed on station. Today, the station design does not have those explosive dangers so station managers are evaluating the need for the cable cutters. For now, a spacewalk would be conducted to remove the cable in the future if the MT ever gets hung up. Cutting the cable renders the TUS-RA unusable on orbit. Since the cause of the TDA failure is not known, NASA and Boeing have worked out a procedure to install a cable blade blocker, a clamp-like device that prevents the cutter blade from moving.

On the first spacewalk during STS-121, the crew will carry a new IUA without the TDA and a cable blade blocker. When they arrive at the zenith IUA, the astronauts will look at it and if it has not fired, they will install the cable blade blocker. The first spacewalk will focus on the zenith IUA to place it in a configuration using the blocker that allows the mobile transporter to translate. If they are successful, then the astronauts will not have to remove the IUA and can install the IUA on the nadir side, which fired on Dec. 16.

If the blade blocker cannot be installed, then the astronaut will remove the zenith IUA that has not been fired yet and will install the brand new one in its place, then connect the TUS cable. The mobile transporter can translate using only one cable. The astronauts will bring the IUA inside and sometime between the first and second spacewalks, they will fix the zenith IUA by removing the TUS Disconnect Actuator. To remove the TDA, astronauts will remove six bolts and power and data connectors.

Between the first and second spacewalks, the mobile transporter will have to be moved from work site 4 to 5 to allow access to remove the TUS-RA. The mobile transporter is in a position that makes its extremely difficult to pull out the TUS-RA, so the goal of the first spacewalk is to make the mobile transporter operational again using one cable.

On the second spacewalk, the astronauts will go out with the IUA and replace the TUS-RA

and then the IUA. The replacement TUS-RA will be located on the ICC towards the front of the orbiter payload bay. The TUS-RA will be positioned by the shuttle's robotic arm. TUS-RA is about 30 feet from the IUA. The EVA will consist of first installing the TUS-RA and then dragging the cable out of the reel and connecting it to the IUA. The oven-sized TUS-RA requires no bolts for installation and there is a spring loaded handle that snaps into place. The TUS-RA has two pins that slide and rotate about 100 degrees to secure it in place and a third point that latches it in like a tripod. The TUS cable is then snaked along the truss, with the astronauts working their way toward the nadir IUA, which will be replaced. Following both spacewalks, there will be no functional TDAs on either IUA. A TUS-RA and IUA will be brought back and refurbished as spares.

### **LIGHTWEIGHT MULTIPURPOSE EXPERIMENT SUPPORT STRUCTURE CARRIER (LMC)**

A third item carried in the payload bay is called the LMC. The LMC will carry a large box with a lid, a DTO, that astronauts will open up during a tentatively planned spacewalk to conduct several tile and RCC panel repair experiments while on orbit. The experiment will check the proof of concept of tile and RCC panel inspection and repair methods. The LMC is a cross-the-bay carrier. The LMC will weigh 2,103 pounds.



# EXPERIMENTS

Detailed Supplementary Objectives (DSOs) are space and life science investigations. Their purpose is to:

- Determine the extent of physiological deconditioning—loss of physical fitness—resulting from spaceflight
- Test countermeasures to those changes
- Characterize the environment of the space shuttle and/or space station relative to crew health

Detailed Test Objectives (DTOs) are aimed at testing, evaluating or documenting space shuttle systems or hardware, or proposed improvements to the space shuttle or space station hardware, systems and operations.

Such experiments assigned to STS-121 are listed below.

## DETAILED SUPPLEMENTARY OBJECTIVES (DSO)

### DSO 490B BIOAVAILABILITY AND PERFORMANCE EFFECTS OF PROMETHAZINE DURING SPACEFLIGHT (PROTOCOL B)

Promethazine (PMZ) is the anti-motion sickness medication (otherwise referred to as Phenergen®), used to treat space motion sickness (SMS) during shuttle missions. The possible side effects associated with this medication include dizziness, drowsiness, sedation and impaired psychomotor performance, which could affect crew performance of mission operations. Early reports from crew members indicate the central nervous system side effects of PMZ are absent

or greatly reduced in microgravity. Because the body's reaction to drugs and the extent and rate the medication is absorbed in microgravity may be different than on Earth, it could significantly alter drug effectiveness as well as severity of side effects for a given dosage. Therefore, it is important to evaluate how PMZ is absorbed, its effects on performance, and its side effects and effectiveness to determine the optimal dosage and route of administration in-flight. PMZ also affects sleep patterns. During the mission, the crew will wear a device known as an Actiwatch to record sleep and wake data. The crew will complete a Sleep Logbook each morning for analysis postflight.

### DSO 493 MONITORING LATENT VIRUS REACTIVATION AND SHEDDING IN ASTRONAUTS

Latent viruses are important sources of human disease and inhabit more than 90% of the world's adult population. These viruses will be carried by the astronauts into space, and they pose an important health risk especially during long-duration missions. Herpes viruses are the best known examples of latent viruses, and there are eight known human herpes viruses. First experiences with these viruses may result in an acute illness (e.g., chickenpox), and as the symptoms subside, the virus establishes a life-long relationship with its human host. You may go for long periods with no further symptoms. However, several factors, such as stress, may decrease the immune system resulting in an "awakening" of the latent herpes virus. These reactivated viruses may result in no symptoms or may produce significant illness (e.g., shingles). This study investigates the

effects of spaceflight (before, during and after) on the reactivation and shedding of latent viruses in body fluids such as saliva, urine, and blood. Subjects will provide specimens of these fluids for analysis of viruses and substances that allow us to determine if any latent viruses have been reawakened. These include substances produced by the immune system, or by active virus, or by stress. If findings from these studies indicate increased risk of latent viral infections during long space mission, countermeasures will be developed and evaluated for efficacy. Stress intervention and management would be a likely countermeasure candidate; several pharmaceuticals are also available and effective.

#### **DSO 498 SPACEFLIGHT AND IMMUNE FUNCTION (PRE/POST FLIGHT ONLY)**

Astronauts face an increasing risk of contracting infectious diseases as they work and live for longer periods in the crowded conditions and closed environments of spacecraft such as the International Space Station. The effect of spaceflight on the human immune system, which plays a pivotal role in warding off infections, is not fully understood. Understanding the changes in immune function caused by exposure to microgravity will allow researchers to develop countermeasures to minimize the risk of infection.

The objective of this DSO is to characterize the effects of spaceflight on cells which play an important role in maintaining an effective defense against infectious agents. The study's premise is that the space environment alters the essential functions of these elements of human immune response and stressors associated with spaceflight.

Researchers will conduct a functional analysis of neutrophils and monocytes from blood and urine samples taken from astronauts before and

after the flight. They will assess the subjects' pre- and postflight production of cytotoxic cells and cytokine.

This study will complement previous and continuing immunology studies of astronauts' adaptation to space.

#### **DSO 499 EYE MOVEMENTS AND MOTION PERCEPTION INDUCED BY OFF-VERTICAL AXIS ROTATION (OVAR) AT SMALL ANGLES OF TILT AFTER SPACEFLIGHT (PRE/POST FLIGHT ONLY)**

Sensorimotor adaptation to weightlessness during orbital flight leads to perceptual and motor coordination problems upon return to Earth. Researchers hypothesize that there are adaptive changes in how the central nervous system processes gravitational tilt information for the vestibular (otolith) system. Eye movements and perceptual responses during constant velocity off-vertical axis rotation will reflect changes in otolith function as crew members readapt to Earth's gravity. The purpose of this study is to examine changes in spatial neural processing of gravitational tilt information following adaptation to microgravity. Postflight oculomotor and perceptual responses during off-vertical axis rotation will be compared with preflight baselines to track recovery time.

#### **DSO 500 SPACEFLIGHT INDUCED REACTIVATION OF LATENT EPSTEIN-BARR VIRUS (PRE/POST FLIGHT ONLY)**

DSO 500 will study the effects of spaceflight T-cell mediated immunity, especially Epstein-Barr virus (EBV) and reactivation of latent EBV infections. This study will address the mechanisms of the decreased immune function from spaceflight and characterize the replication of latent viruses. Specifically, this study will determine the magnitude of immuno

suppression as a result of spaceflight by analyzing stress hormones. Blood and urine samples are used to analyze the latent viruses.

The successful completion of this study will provide new information on the mechanisms involved in spaceflight-induced EBV reactivation. Correlating the viral reactivation data with the immunological findings will expand the knowledge on the role of the immune system and reactivation of latent viruses in humans during spaceflight.

### **DSO 634 SLEEP-WAKE ACTIGRAPHY AND LIGHT EXPOSURE DURING SPACEFLIGHT**

Spaceflight results in disruption of sleep on short duration missions. The disruption is associated with inappropriately timed light—one dawn and one dusk happen during each 90-minute orbit—or exposure to light that is not intense enough. The success and effectiveness of manned spaceflight depends on the ability of crew members to maintain a high level of cognitive performance and vigilance while operating and monitoring sophisticated instrumentation. Astronauts, however, commonly experience sleep disruption, together with misalignment of circadian phase during spaceflight. Both of these conditions are associated with insomnia and associated impairment of alertness and cognitive performance. Relatively little is known of the prevalence or cause of spaceflight-induced insomnia in short duration missions. This experiment will use state-of-the-art ambulatory technology, an Actiwatch worn on the wrist, to

monitor sleep-wake activity and light exposure patterns obtained in-flight. The crew members will also use sleep logs in the morning to document perceived quality of sleep. These data should help us better understand the effects of spaceflight on sleep as well as aid in the development of effective countermeasures for both short and long-duration spaceflight.

### **DSO 635 SPATIAL REORIENTATION FOLLOWING SPACEFLIGHT (PRE/POST FLIGHT ONLY)**

Spatial orientation is altered during and after spaceflight by a shift of central inner processing—from a gravitational frame-of-reference to an internal, head-centered frame-of-reference—that occurs during adaptation to microgravity and is reversed during the first few days after return to Earth. A previous observation suggested conflicting sensory stimuli caused by an unusual motion environment. This causes a disrupted spatial orientation and balance control in a returning crew member by triggering a shift in central vestibular (inner ear) processing. The short arm centrifuge and posture platform are used to collect the neurovestibular data. The findings of the current investigation are expected to demonstrate the degree to which challenging motion environments may affect how a crew member adapts after the flight. These findings could lead to a better understanding of safe postflight activities and could help designers better understand the characteristics needed for an artificial gravity countermeasure on long duration space station or exploration missions.

## **DSO 637 CHROMOSOMAL ABERRATIONS IN BLOOD LYMPHOCYTES OF ASTRONAUTS (PRE/POST FLIGHT ONLY)**

During spaceflight, crew members are constantly exposed to solar and galactic radiation such as electrons, protons, heavy particles, single particles of high energy (HZE). They are also exposed to secondary radiation created by interactions of primary radiations with nuclei of spacecraft shielding material or the human body. The radiation dosage of each type depends largely on the altitude and inclination of the spacecraft's orbit, effectiveness of the shielding and solar activity during the mission.

Previous studies documented severe damage from single particles of high energy (HZE particles) passing through biological material. Therefore, it can be assumed that despite of their rarity, HZE particles represent a considerable risk for humans in space. The specific effects of HZE particles in humans are not well documented. This investigation studies chromosomal deviations in human blood lymphocytes to assess the potential of ionizing radiation. Blood will be drawn before and immediately after spaceflight. The whole blood will be processed to stimulate the lymphocytes to undergo mitosis. After 48 hours, the cells will be stained and prepared for microscopic analysis. A comparison between pre- and postflight will be made. Because some of the crew members take anti-oxidant vitamins, the data will be correlated with intake information to determine if that affects the results. The data from the study should lead to better radiation protection for crew members.

## **DETAILED TEST OBJECTIVES (DTO)**

### **DTO 702 MADS PCMU TO SSR TELEMETRY**

The objective of the DTO is to demonstrate if the modified Modular Auxiliary Data System (MADS) Pulse Code Modulation Unit (PCMU) hardware using a new solid state recorder (SSR) and low-pass filter can provide telemetry for orbiter vehicle data that was recorded on MADS PCMU during the ascent phase and downlink the recorded data during the on-orbit phase of flight. The ground processing systems, primarily the Mission Control Center front end processor (FEP) were modified to receive the downlinked telemetry and process the data in real time and will be operated during the flight test.

### **DTO 805 CROSSWIND LANDING PERFORMANCE (IF OPPORTUNITY)**

The purpose of this DTO is to demonstrate the capability to perform a manually controlled landing in the presence of a crosswind. The testing is done in two steps.

1. Pre-launch: Ensure planning will allow selection of a runway with Microwave Scanning Beam Landing System support, which is a set of dual transmitters located beside the runway providing precision navigation vertically, horizontally and longitudinally with respect to the runway. This precision navigation subsystem helps provide a higher probability of a more precise landing with a crosswind of 10 to 15 knots as late in the flight as possible.
2. Entry: This test requires that the crew perform a manually controlled landing in the presence of a 90-degree crosswind component of 10 to 15 knots steady state.

During a crosswind landing, the drag chute will be deployed after nose gear touchdown when the vehicle is stable and tracking the runway centerline.

### **DTO 848 ORBITER THERMAL PROTECTION SYSTEM (TPS) REPAIR TECHNIQUES**

Reinforced carbon carbon (RCC) samples will be flown in a thermal protection system sample box located on the upper surface of the LMC (lightweight mission peculiar equipment support structure carrier). If consumables allow an extra day and a third spacewalk, the crew will perform setup activities on the SSRMS (space station remote manipulator system) and the payload bay to allow them to perform RCC sample repairs. The samples within the box provide the crew with the capability to perform RCC crack repairs using a material called NOAX or Non-Oxide Adhesive eXperimental. An applicator similar to a caulking gun will be used to insert the material into the crack. The NOAX will come out of the applicator gun looking like thick, dark-chocolate pudding. The crew will then use a trowel to apply the material, layering it, over the damaged area. The objective is to thoroughly fill the cracks creating a smooth surface and to gather information about how the material responds in zero-G. The samples repaired by the crew will be returned for ground testing.

NOAX combines a pre-ceramic polymer sealant and carbon-silicon carbide powder. It was developed to survive very high temperatures, such as those experienced during re-entry of the shuttle.

### **DTO 849 OBSS SRMS LOADS CHARACTERIZATION WITH EVA CREW MEMBERS**

For this DTO, STS-121 EVA crew members Sellers and Fossum will conduct a spacewalk on the OBSS boom attached to the SRMS. The OBSS boom/SRMS system as an EVA platform is a contingency vehicle inspection capability for current shuttle flights (if OBSS sensors fail) and will be used as the vehicle repair platform starting with ISS flight 10A (delivery of Node 2). The stability of this platform is unlike any EVA platform used on-orbit to date. The purpose of this DTO is to characterize the motion of the boom under inspection and repair-like actions, to verify the inspection capability and to understand the requirements for operational constraints, boom modifications, and/or supplemental hardware that will be required to perform a vehicle repair. The DTO will also help to validate ground simulators that have been developed to train crews and provide engineering data for certification of repair hardware and operations.

The DTO is planned to include several different combinations of crew member configurations, simulated tasks, SRMS positions and APFR positions to gather information on as many variables as possible. The DTO builds from a more stable configuration (stiffer SRMS position with a single crew member) with more benign operations to less stable configurations (less stiff SRMS positions with two crew members) with more aggressive operations. The DTO incorporates special test hardware (Instrumented WIF or IWIF) specifically designed to gather loads and acceleration data at the crew members foot restraint during the DTO. The IWIF uses a load cell and wireless data recorders to gather the DTO data.

The types of crew actions that will be executed during the DTO include camera operations, tool hand-offs, APFR reconfiguration, laying back and leaning forward in the foot restraint, ingressing and egressing the APFR and simulated vehicle repair techniques required by the current vehicle repair methods (scraping, dabbing, drilling, installing overlays, etc.). Three different APFR positions and four SRMS positions are used for the evaluations. One SRMS position will put the crew members near ISS structure to simulate an actual vehicle repair worksite.

### **DTO 850 WATER SPRAY BOILER COOLING WITH WATER/PGME ANTIFREEZE**

Water spray boilers, after spraying water, freeze every time auxiliary power units are shut down and remain frozen for unpredictable amounts of time. A solution is to replace water as the cooling fluid in the water spray boiler tank with an azeotropic mixture of 53 percent water and 47 percent propylene glycol monomethyl ether (PGME). Tests done at White Sands Test Facility in New Mexico show that a water/PGME mixture is not likely to freeze in the conditions seen on orbit. A water/PGME mixture turns to slush at about -40 degrees Fahrenheit and freezes at -54 degrees F.

The plan is to fill only water spray boiler No. 3 water tank with a water/PGME mixture. The primary objective is to confirm ground test results for water spray boiler in the post-ascent, high-vacuum, zero-G environment. A secondary objective is to confirm coolant usage is within predictions.

The pilot will perform the water spray boiler cooling verification.

### **DTO 851 EVA INFRARED (IR) CAMERA**

The criteria for assessing the extent and severity of wing leading edge (WLE) reinforced carbon-carbon (RCC) damage includes cracks, coating loss, and sub-surface separation. The orbiter boom sensor system (OBSS) and EVA digital camera are both capable of detecting certain cracks and coating loss. However, neither of those systems is capable of detecting RCC subsurface separation, or delamination. Infrared (IR) thermography—recording an image of heat—is the most promising technology for detecting RCC subsurface delamination while on orbit.

If consumables allow an extra day and third spacewalk, as time allows, the crew is to retrieve the infrared camera and record video clips of the RCC. The objective is to video the orbiter wing leading edge (WLE) during both day and night passes. This is to be done from a distance that allows multiple WLE RCC panels to be recorded at the same time. The second priority is recording specific RCC samples located within the thermal protection system sample box. The two samples are 6 inch by 6 inch and were purposely damaged on the backside prior to flight. The crew will begin recording the samples while in direct sunlight and then shade the samples a few seconds. This will allow the camera to record the heat flux of the samples, providing information about damage.

### **DTO 852 SRMS ON-ORBIT LOADS, HEAVY PAYLOADS**

The objective of the DTO is to characterize the loads—the weight and force exerted on a structure—that are induced into the SRMS during “non-typical” loaded SRMS operations and to correlate these SRMS loads to math models. “Non-typical” operations are operations that fall outside the current

historical operational information. This includes operations such as heavy payload maneuvering and interaction with a vehicle's motion control system, payloads that don't meet current SRMS requirements or new operational techniques like EVA worksite stabilization at the end of the grappled OBSS. This loads data will be used by the NASA to validate current analytical tools to actual flight information versus simulation to simulation comparisons that are being worked today. This is important information as NASA prepares to provide a stable worksite for crew members to repair the orbiter's thermal protection system.

### **SDTO 12004-4 SHUTTLE BOOSTER FAN BYPASS**

This Station Development Test Objective (SDTO) will optimize cryogenic oxygen savings by operating the booster fan differently within the context of the flight rules and expenditure of other resources (crew time, LiOH, etc.). Shuttle on-orbit cryogenic oxygen margin can be increased on space station missions if the shuttle booster fan (also known as the airlock fan) is bypassed post docking. While docked, sufficient space station/shuttle air circulation will be achieved through the use of the U.S. Laboratory Forward Intermodule Ventilation (USL IMV) fan so that carbon dioxide levels on both the station and shuttle can be controlled during the day by the station. Nominally, while the shuttle is docked to the station, active ventilation has included use of the shuttle booster fan and the station IMV fan. During the overnight period, additional remediation may be required to control carbon dioxide levels in the shuttle. The crew may be instructed to install LiOH on the middeck to supplement the carbon dioxide removal provided by the station, or reconfigure the duct and turn on the booster fan.

### **SDTO 13005-U ISS STRUCTURAL LIFE VALIDATION AND EXTENSION**

The International Space Station structure has a 15-year life requirement. The overall objective is to guarantee safety of the station structure and crew. Specific objectives are to accurately determine structural life usage, to expand station operations and to increase the life of the structure. Structural life estimates are based on worst case loading conditions using finite element models of structures and forcing function estimations. It is desirable to reduce this conservatism through post-flight reconstructions using correlated models, validated forcing functions, measured station response data and actual on-orbit loading conditions. This reconstruction requires actual or educated estimates of input (forcing function) and actual output (on-orbit sensor measurements) of the station response. Measurement of the force input (i.e., thruster firing sequences, video of crew activity) and station response will aid reconstruction of station loads and structural life usage over the life of the station, thus allowing life extension of the structure.

### **SHUTTLE (SORTIE) EXPERIMENTS**

#### **Fungal Pathogenesis, Tumorigenesis, and Effects of Host Immunity in Space (FIT)**

studies the susceptibility to fungal infection, progression of radiation-induced tumors and changes in immune function in sensitized *Drosophila*, or fruit fly, lines.

#### **Effect of Spaceflight on Microbial Gene Expression and Virulence (Microbe)**

will investigate the effects of the spaceflight environment on the infectiousness of three model microbial pathogens identified during previous spaceflight missions as potential threats to crew health.

**Maui Analysis of Upper Atmospheric Injections (MAUI)** observes the exhaust plume of the space shuttle from the ground, leading to an assessment of spacecraft plume interactions with the upper atmosphere.

**Ram Burn Observations (RAMBO)** is a Department of Defense experiment that observes Shuttle Orbital Maneuvering System engine burns by satellite for the purpose of improving plume models. Understanding the spacecraft engine plume flow could be significant to the safe arrival and departure of spacecraft on current and future exploration missions.

## **EXPERIMENTS DELIVERED TO ISS**

**Passive Observatories for Experimental Microbial Systems (POEMS)** will evaluate the

effect of stress in the space environment on the generation of genetic variation in model microbial cells. POEMS will provide important information to help evaluate risks to humans flying in space to further understand bacterial infections that may occur during long-duration space missions.

**Analysis of a Novel Sensory Mechanism in Root Phototropism (Tropi)** will observe the growth and collect samples of plants sprouted from seeds. By analyzing the samples at a molecular level, researchers gain insight on what genes are responsible for successful plant growth in microgravity.



## FUNGAL PATHOGENESIS, TUMORIGENESIS AND EFFECTS OF HOST IMMUNITY IN SPACE (FIT)

**Principal Investigator(s):** Sharmila Bhattacharya, Ph.D., Ames Research Center, Moffett Field, Calif., and Deborah Kimbrell, Ph.D., University of California Davis, Davis, Calif.

**Payload Developer(s):** Ames Research Center

**Increment(s) Assigned:** 13

### Research Summary

This study will investigate the susceptibility to fungal infection, progression of radiation-induced tumors, and changes in immune function in sensitized *Drosophila* (fruit fly) lines.

- This experiment will study the growth of cancerous and benign tumors in sensitized genetic lines (breeds) of *Drosophila melanogaster* (fruit flies) that show an increase in the incidence of tumor formation. The effect of radiation exposure will be coupled to this study.
- In addition, samples of a fungal pathogen that infects flies will be exposed to radiation and the space environment. Space-flown samples will be used post-flight to infect *Drosophila* on the ground and assess changes in the pathogen.
- These studies will provide more information on the interaction between elements of the space environment (space radiation, microgravity) and immune function and tumor growth.

### Research Operations

This experiment requires the crew to monitor the cassette for temperature stability. Researchers will analyze changes in blood cell, hematopoietic organ (lymph gland) and fat body (liver) morphology from postflight samples.

### Flight History/Background

The STS-121 mission will be the first flight for this experiment.

### Web Site

For more information on FIT, visit:

<http://exploration.nasa.gov/programs/station/list.html>

## ANALYSIS OF A NOVEL SENSORY MECHANISM IN ROOT PHOTOTROPISM (TROPI)

**Principal Investigator:** John Kiss, Ph.D., Miami University, Oxford, Ohio

**Payload Developer:** Ames Research Center, Moffett Field, Calif.

**Increment(s) Assigned:** 13

### Research Summary

Plants sprouted from seeds will be videotaped and samples collected to be analyzed at a molecular level to determine what genes are responsible for successful plant growth in microgravity. Insights gained from Tropi can lead to sustainable agriculture for future long-term space missions.

The primary objectives of Tropi are:

- To understand the mechanisms by which plant roots respond to varying levels of both light and gravity.
- To determine how plants organize multiple sensory inputs, like light and gravity.
- To gain insight into how plants grow in space to help create sustainable life support systems for long-term space travel.

### Research Description

Tropi consists of dry *Arabidopsis thaliana* (thale cress) seeds stored in small seed cassettes. *Arabidopsis thaliana* is a rapidly growing, flowering plant in the mustard family.

The seed cassettes will be flown inside the European Modular Cultivation System (EMCS). The seeds will remain dry and at ambient temperature until hydrated by an automated system of the EMCS. At specified times during the experiment, the plants will be stimulated by different light spectrums and by different gravity gradients. The only work required by the crew is to replace videotapes and harvest the plants when they are grown. Once the plants are harvested, they will be stored in the Minus Eighty Degree Laboratory Freezer for ISS (MELFI) until their return to Earth.

### Web Site

For more information on Tropi, visit:

<http://exploration.nasa.gov/programs/station/list.html>

# SPACE SHUTTLE SAFETY ENHANCEMENTS OVERVIEW

## SPACE SHUTTLE DISCOVERY – STS-121/ULF1.1

### SETTING THE STAGE FOR RESUMPTION OF ASSEMBLY

Space Shuttle Discovery is set to resume service to the International Space Station with launch targeted for July 1 during a window extending through July 19. It is a test flight and the second in a series to validate improvements through a structured test program put in place following the Columbia accident in 2003.

While the Return to Flight mission last July completed all mission objectives by resupplying the station and restoring full capability to its attitude control system, during launch a piece of foam was shed from the external tank which clearly was unacceptable for continued operations.

The Space Shuttle Program determined the foam area of concern could safely be removed based on preliminary engineering analysis and testing continues to verify the computer analysis. While the analysis continues, work proceeded on shuttle components in order to be ready to launch as soon as the analysis of completed testing proves it is safe to do so.

Removal of the nearly 40 pounds of foam required extensive work to prove the overall structural integrity of the shuttle system (orbiter, boosters and external tank) prior to flight. The foam “ramps,” as they are known, were put in place early in the shuttle program

because they alleviated the need for this type of analysis and testing via technology that—at the time—did not exist.

Now that supercomputers and advances in technology are available, it is possible to prove the tank structure is more robust to handle any loads that would be experienced during the early minutes of launch.

So Discovery and its seven-member crew is poised once again to return to the International Space Station for a supply mission and to restore the station’s crew to three, which last was supported in early 2003.

The stage will then be set to resume assembly of the ISS with Atlantis in August/September leading toward completing the construction and addition of international partner laboratories and components.

As with every flight remaining before the shuttle is retired at the end of 2010, Discovery’s mission is more than a single flight.

That in turn provides another major stepping-stone to the long range planning in the form of the Vision for Space Exploration announced in January 2004.

NASA has committed itself to excellence in all aspects of its programs by strengthening its culture and improving technical capabilities.



# PREPARING THE EXTERNAL TANK

## RETURN TO FLIGHT EXTERNAL TANK, ET-119

About six hours before Space Shuttle Discovery's launch, the bright orange 15-story-tall fuel tank is loaded with 535,000 gallons of liquid hydrogen and oxygen. Just before liftoff, these super cold liquids are mixed and burned by the shuttle's three main engines, which gulp it at a rate equal to emptying the average size backyard swimming pool in 20 seconds.

The external tank's aluminum skin is a tenth-of-an-inch thick in most places and is covered with polyurethane-like foam averaging an inch thick, which insulates the propellants, prevents ice formation on its exterior, and protects its skin from aerodynamic heat during flight. About 90 percent of the foam is applied by automated systems, while the remainder is applied manually.

### PROTUBERANCE AIR LOAD (PAL) RAMPS

ET-119 is the first external tank to fly without Protuberance Air Load Ramps—manually sprayed wedge-shaped layers of foam along the pressurization lines and cable tray on the side of the tank. They were designed as a safety precaution to protect the tank's cable trays and pressurization lines from air flow that could potentially cause instability in these attached components. Previously, there were two PAL ramps on each external tank. One was near the aft end of the liquid oxygen tank, just above the intertank, and the other was below the intertank, along the upper end of the liquid hydrogen tank. Both ramps extended about 5 feet into the intertank area. The liquid oxygen PAL Ramp was 13.7 feet long and the liquid

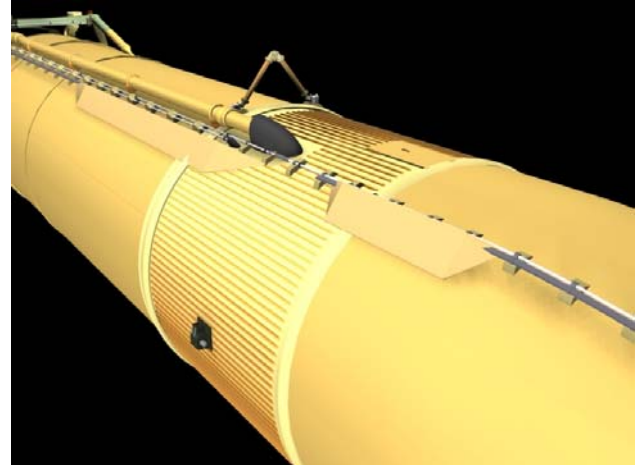

**PAL ramps, manually sprayed wedge-shaped layers of foam along the tank's pressurization lines and cable tray.**

hydrogen PAL Ramp was 36.6 feet long. The weight of foam removed was 37 pounds total.

During the STS-114 mission in July 2005, video analysis indicated a piece of foam – approximately 36 inches long at the longest point and approximately 11 inches wide at its widest point – was lost from the external tank. The location of the foam loss was approximately 15 feet below the flange that joins the intertank to the liquid hydrogen tank, or approximately 20 feet from the top of the liquid hydrogen PAL ramp. The event occurred at 127 seconds into the flight. The imagery review, as well as on-orbit and post-flight inspections, indicated the debris did not impact Discovery.

The external tank project has spent nearly three years testing and analyzing the aerodynamics of the cable trays and pressurization lines to determine the need for the ramps. Enhanced structural dynamics math models were created

to better define the characteristics of this area of the tank and scaled models of the tank were tested in wind tunnels at the Marshall Space Flight Center in Huntsville, Ala.; NASA's Langley Research Center in Hampton, Va.; NASA's Glenn Research Center in Cleveland, Ohio; and at the Canadian National Research Council wind tunnel in Ottawa. A full-scale model of this section of the tank also was tested in a wind tunnel at the Arnold Engineering and Development Center at Arnold Air Force Base, Tenn. Computational fluid dynamics work was completed on full-stack (tank, boosters and orbiter) models to better determine the aerodynamic flow in this area.

Following STS-114, external tanks at NASA's Kennedy Space Center, Florida, were returned to the Michoud Assembly Facility outside New Orleans for detailed inspection of these PAL ramps as part of investigative work to understand and identify the most likely root cause of the foam loss.

Two teams were assigned to review foam performance and determine the most likely root causes. One team, composed of NASA's top government and contractor experts on the space shuttle external tank, investigated the foam loss with the intent of determining root cause. Another team, chartered by the Space Operations Mission Directorate at NASA Headquarters in Washington, performed an independent engineering assessment of work required to resolve the foam loss issue.

Three redesign options were studied as possibilities for future improvements to the external tank. These included removing the PAL Ramp from the tank; modifying the PAL ramp to a smaller configuration (mini-ramp); and installing a trailing edge fence on the back side of the cable tray. The no-PAL Ramp option was chosen because recent testing of

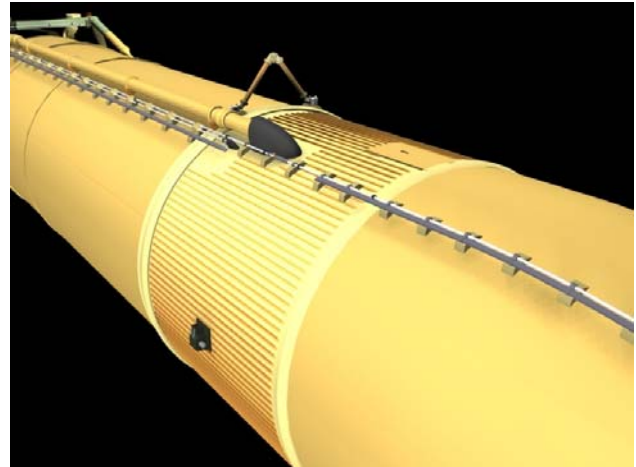

**External tank with PAL ramps removed for the STS-121 mission.**

actual flight hardware demonstrated the current cable tray design did not pose an instability concern.

A detailed verification and validation plan addressed the entire spectrum of changes needed to remove the PAL ramp, including foam elimination and impacts to the attached hardware, including cable trays, pressurization lines and support brackets. Engineering processes included detailed modeling of the tank to validate any changes. Additional tests are planned to ensure that required design safety factors have been maintained on all components.

Rigorous analysis and testing is under way to establish that the external tank can be flown safely without the PAL ramps. Testing to verify aeroelastic, aerodynamic and aerothermal loads was completed, indicating that flying the tank without the PAL ramp did not pose additional instability, pressure or heating concerns.

Wind tunnel testing and computational fluid dynamics testing, using computers to study liquids and gases in motion, will verify that the design environments provided to the External Tank Project envelope the flight environment.

## ICE/FROST RAMPS

The main propulsion system pressurization lines and cable trays are attached along the length of the tank at multiple locations by metal support brackets. These metal brackets are protected from forming ice and frost during tanking operations by foam protuberances called ice/frost ramps. There are 34 ice/frost ramps on the tank, 12 on the liquid oxygen tank, six on the intertank and 16 on the liquid hydrogen tank. The size of the ice/frost ramps is dependent upon location. The smaller ramps on the liquid oxygen tank are roughly 1.5 feet long by 1.5 feet wide by 5 inches high. Each weighs about 12 ounces. The larger ramps on the liquid hydrogen tank are roughly 2 feet long by 2 feet wide by 1 foot high. They weigh approximately 1.7 pounds each.

Ascent/on-orbit imagery from STS-114 indicated foam loss from three liquid hydrogen ice/frost ramps. One piece of foam was approximately 7 inches by 2 inches, in a location approximately 15 feet from the top of the liquid hydrogen PAL ramp.

Nondestructive evaluation techniques and dissection activity on one tank in the inventory (ET-120) which had undergone several pre-flight sequences of cryogenic chill-down and pressurization to flight-like levels revealed cracks in ice/frost ramps. During dissection of one crack, a portion of the base foam was found to have vertical and horizontal cracks which separated into layers near the substrate, or base aluminum skin of the tank.

Options to resolve the ice/frost ramp cracks are being studied, including the possibility of reshaping the ramps to reduce thermal stresses in the foam and to reduce the amount of foam used on each ramp. Wind tunnel tests are being conducted to verify the possibilities for

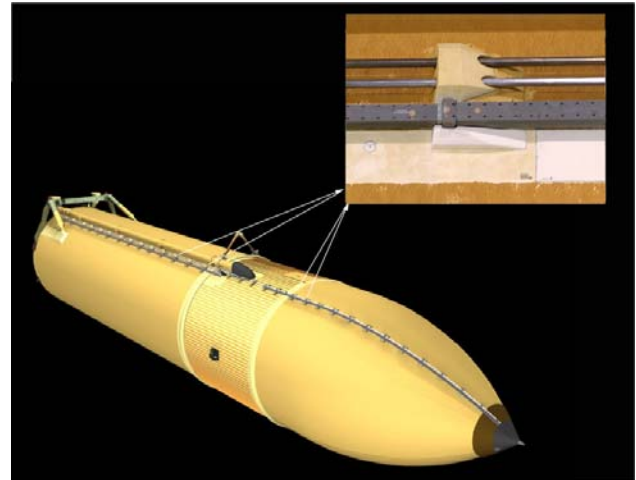

**Ice/frost ramps are foam segments that protect against ice and frost formation. There are 34 ice/frost ramps on the tank.**

any redesign. The Space Shuttle Program management made a decision in April 2006 to fly the ice/frost ramps in their current configuration. The rationale for doing so was based on several factors including the performance of the ice/frost ramps on previous flights. Any design changes would need to be thoroughly tested and certified before modifying the tank. To do otherwise could result in more uncertainty instead of reducing risk of the tank.

Small foam ramps, called ice/frost ramp extensions, have been added to the ice/frost ramp locations where the PAL ramps were removed. The new extensions were added to make the geometry of these ice/frost ramps consistent with other locations on the tank.

Testing and analysis continues for modifications to the ice frost ramp. New cameras will allow better insight into the current ramp performance, which will help in the redesign effort. Flying the current ice/frost ramps limits the design changes on the tank, which has already undergone a significant redesign with the removal of the Protuberance Air Load (PAL) ramp.



**Current Ice/Frost Ramp**

## BIPOD CLOSEOUT

Ascent/on-orbit imagery from STS-114 documented a 7-inch-by-8-inch divot, or lump of missing foam, near the tank's left hand bipod attachment fitting. The bipod fittings use electric heaters to prevent ice buildup—a potential debris source—on bipod fittings. The bipod design requires cabling to operate the heating system and includes eight circuits—four for each bipod fitting—that run from the external tank ground umbilical carrier plate to the heaters which are under the fittings themselves. These fittings connect the external tank to the orbiter through the shuttle's two forward attachment struts.

Analysis indicates a probable cause of the divot during the STS-114 mission was cryoingestion, where gases are pulled or ingested through leak paths into regions under the foam at cryogenic temperatures. These gases condense into liquid during tanking on the launch pad, and later expand back into gases during ascent as the tank structure warms. This rapid expansion can cause increases in pressure under the foam, potentially causing divots to be liberated. For the bipod, the leak path for this gas could have been through the heater or temperature sensor

wiring harness. Another potential contributor to the cryoingestion scenario is the voids found in the material used to bond the wire harnesses to the substrate. These voids can act as reservoirs for the liquid nitrogen ingested through the harness.

To correct these problems, electrical harnesses that service the bipod heaters and temperature sensors were removed and replaced with improved versions that are designed to reduce the potential for nitrogen leakage from the intertank through the cables into the cryogenic region near the bipod fittings. Void spaces beneath the cables were eliminated by using an improved bonding procedure to ensure complete adhesive coverage.

Testing and analysis has confirmed this modification will significantly improve the performance of the foam in the bipod closeout area.



**Bipod Installation**

## INSTRUMENTATION

External Tank ET-119 has the same development flight instrumentation (DFI) suite as External Tank ET-118, which is the fuel tank designated for the STS-115 mission. Instrumentation, to make measurements during flight, includes accelerometers in both the liquid oxygen and liquid hydrogen cable trays.



# ENHANCED SHUTTLE-BASED CAMERA VIEWS

New and modified cameras on the space shuttle solid rockets, external tank and on Discovery will greatly increase the views available to verify that there is no hazardous debris or damage during ascent.

The cameras increase the capability to monitor the ascent environment, including debris, and verify the health of the shuttle's thermal protection system and the redesigned portions of the external tank.

Enhancements include reinstating previously used digital cameras on the shuttle solid rocket boosters; a video camera on the external tank; a remote electronic still camera on the underside of the shuttle to replace a previous film camera in that location; and crew handheld digital photography of the tank that can be processed onboard the shuttle for transmission to the ground.

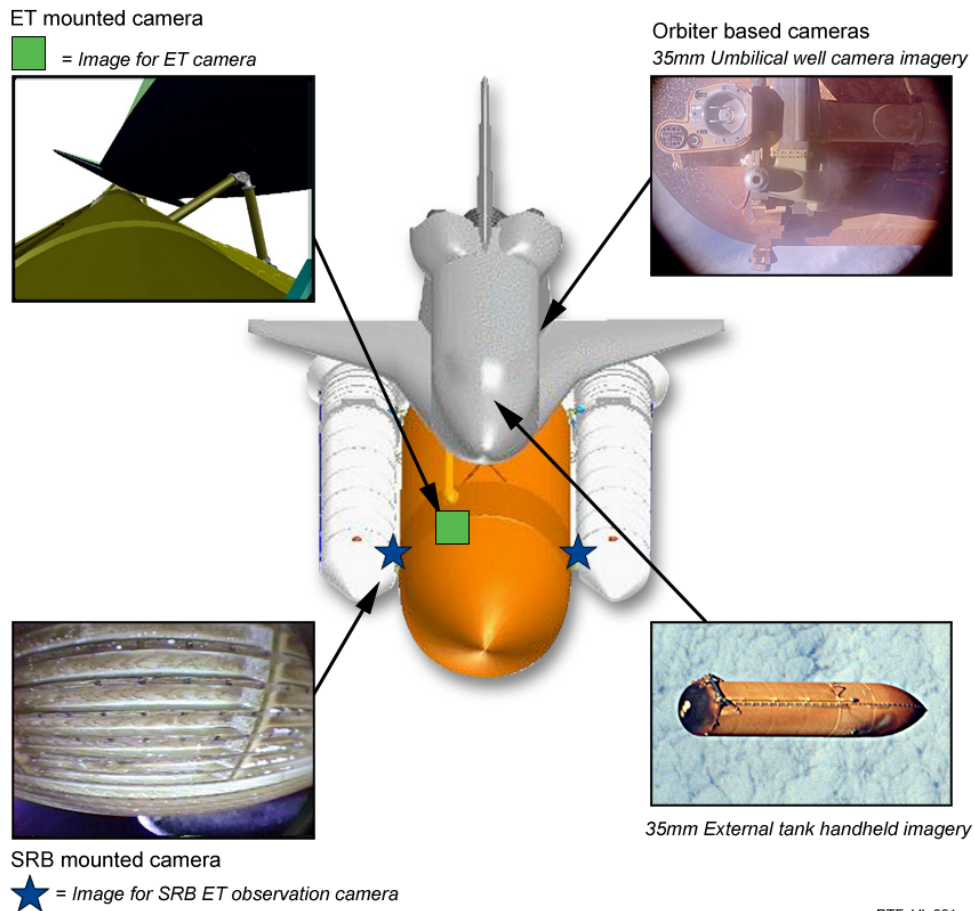

**Cameras on the Space Shuttle Boosters, External Tank and Orbiter**

Together, these steps are part of a project known as the enhanced launch vehicle imaging system (ELVIS).

The tank-mounted camera provides supplementary imaging to that gained through in-flight inspection with the orbiter boom and sensor system. Beginning with STS-121, additional cameras were added to the solid

rockets to provide better views of the wings during ascent.

## EXTERNAL TANK-MOUNTED CAMERA

A television camera on the exterior of the external tank located several feet above the right bipod area in the liquid oxygen feedline fairing housing is the same as used on space shuttle mission STS-114 in July 2005.

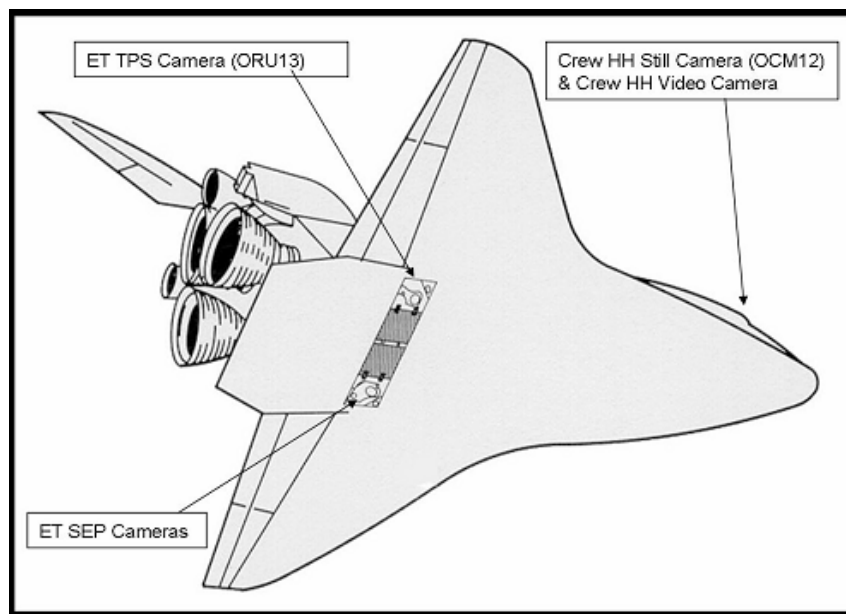

Shuttle Orbiter-Based Photography for STS-121 Ascent

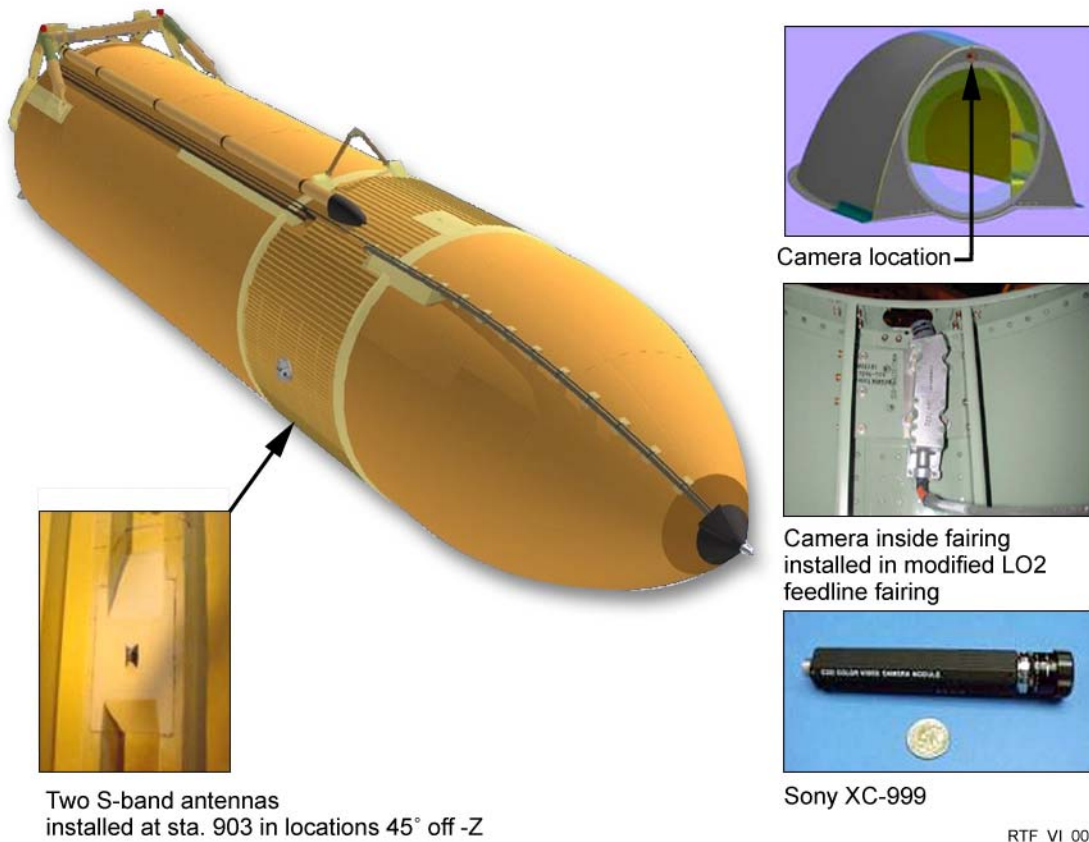

RTF\_VI\_004.png

### External Tank Camera Overview

The camera is a Sony XC-999 secured in a modified, space-hardened housing. It is about the size of two C batteries laid end-to-end and is of a type commonly referred to as a "lipstick" camera. The camera's views will be transmitted to the ground in real time via the ground communications station at Merritt Island, Fla., during the shuttle's climb to orbit.

The transmission occurs through an electronics package located within the central part (intertank) of the external tank, which joins the oxygen and hydrogen tanks. The electronics box houses batteries, a 10-watt transmitter and other equipment. The signal is sent to the ground via antennas located on the exterior back side of the tank, almost directly opposite the camera's location.

The new tank camera is expected to remain in the same configuration for all remaining missions.

### SOLID ROCKET BOOSTER CAMERAS

Previously used cameras – one on the left solid rocket and one on the right – provide views of the intertank for STS-121. The cameras are located just below the nose cone of each booster and do not provide real-time views during launch. Their imagery is recorded for playback after their retrieval from the Atlantic Ocean.

Two additional cameras on each booster are at the tank's attach ring, about one-quarter of the way up each rocket. Another camera has been added to the forward skirt of each booster,

where each rocket's nose cone and main body intersect.

The forward skirt cameras will look aft to provide views of the shuttle wing leading edges. The tank attach ring cameras will look forward to provide views of the wing and fuselage underside tiles. All cameras will record imagery on the rockets for viewing after they have been recovered. They will not provide real-time television views during launch.

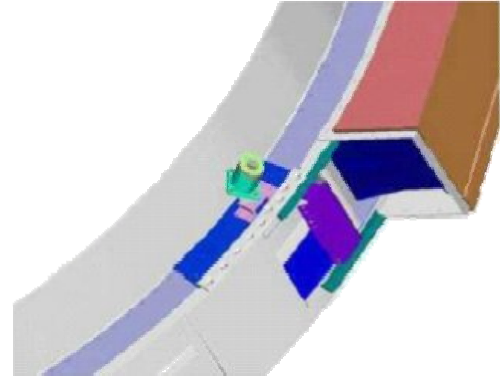

**ET Ring Camera Housing Installed**

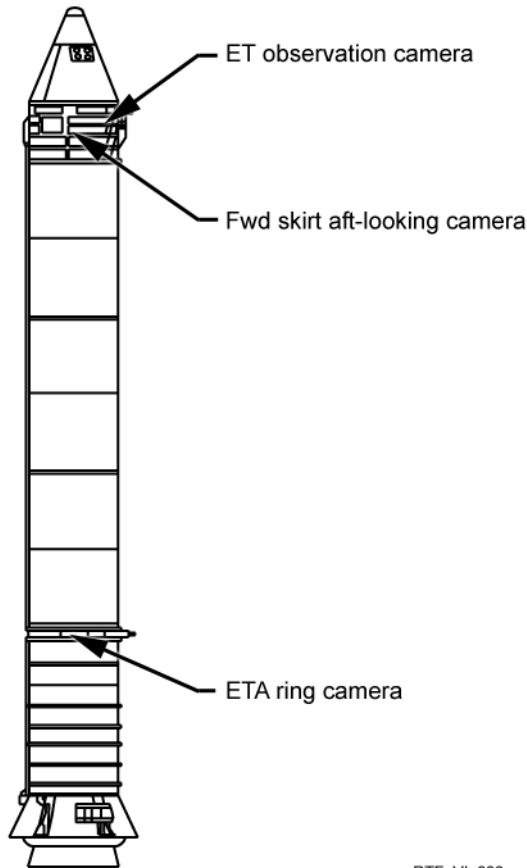

RTF\_VI\_006.png

**SRB-Mounted Cameras**

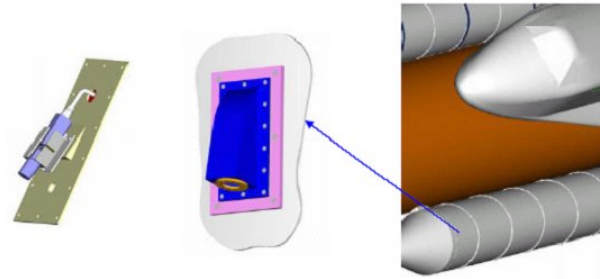

**Forward Skirt Aft-Pointing Camera  
Prototype Housing**

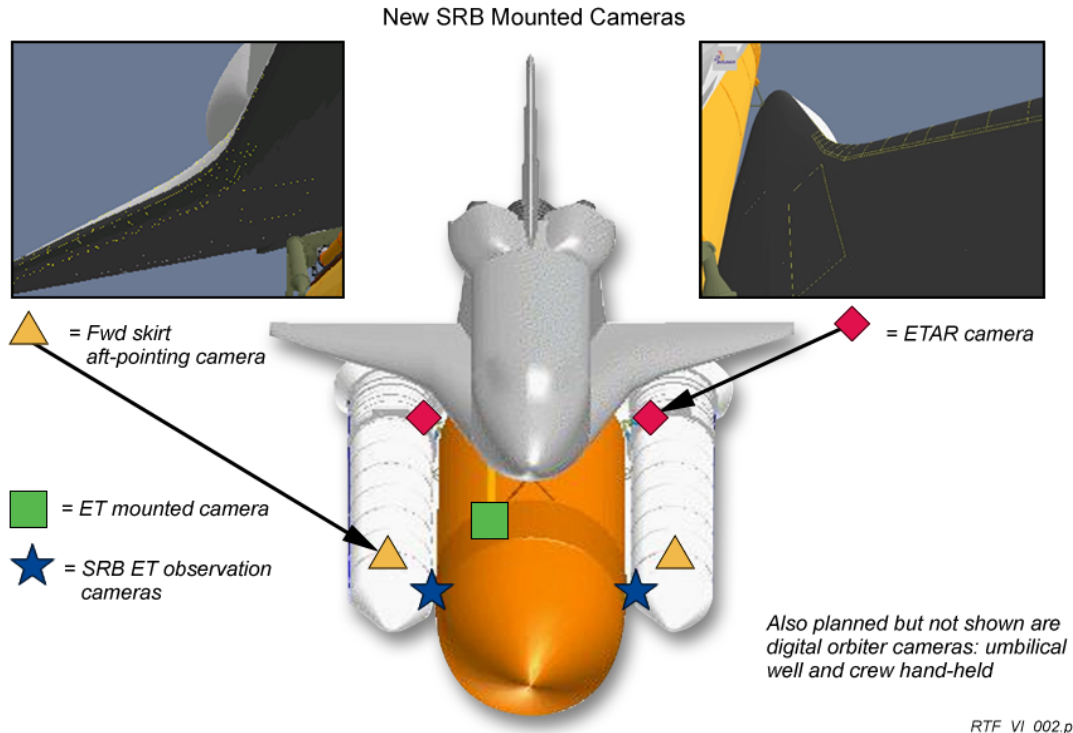

### Camera Configuration

#### EXTERNAL TANK UMBILICAL WELL DIGITAL STILL CAMERA

A 35mm still camera previously located in the right umbilical well on the underside of the orbiter has been replaced with a Kodak DCS760 digital still camera. The new camera will take digital images of the tank after it has separated from the orbiter and feed them to a laptop computer in the crew cabin. The crew then will downlink those images to Mission Control for analysis early in the flight.

The left umbilical well will continue to have two film cameras as has been flown on previous missions to gather movie imagery for use in analysis after it has been returned to Earth.

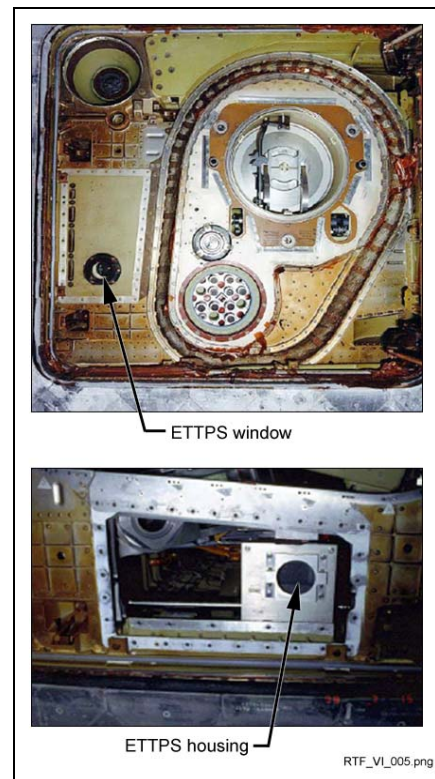

#### Right-Hand Umbilical Well

## CREW HAND-HELD PHOTOGRAPHY

The crew's procedures in photographing the external tank after it has separated from the orbiter have been modified to use a digital still camera Kodak DCS760. The hand-held digital camera has been flown on many past missions, but never before has been used for imagery of the tank after launch. Previously, imagery of the tank was taken by the crew using a hand-held film camera and saved for analysis after the shuttle's return to Earth.

The hand-held digital images of the tank will be transferred to a laptop computer and then transmitted to Mission Control early in the

mission for analysis. Along with the photography taken by the umbilical well digital camera, the handheld digital images will assist ground technicians in characterizing the condition of the tank as it was jettisoned. They will assist in characterizing any foam loss and verifying the flight operation of tank design changes that have been made.

To photograph the tank, the orbiter will be pitched over shortly after the tank has separated to optimize its view from the overhead cabin windows. This maneuver will be done a few minutes earlier to improve the resolution of the imagery.

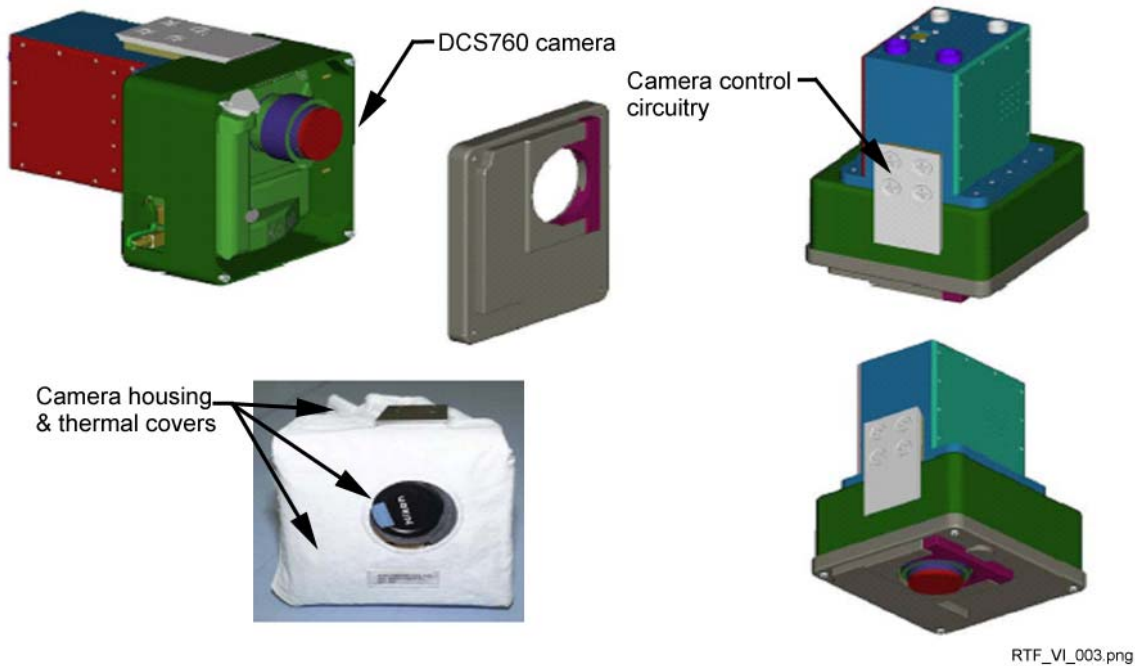

Digital Umbilical Still Camera System

## DIGITAL SPACEWALK CAMERA

A new hand-held digital camera for use by spacewalkers outside the vehicle will be flown on all flights. Previously, cameras used by spacewalkers outside the vehicle had been film cameras. The new extravehicular activity (EVA) camera is a Kodak DCS760 camera, the same camera used for digital imagery inside the shuttle cabin, with some modifications made to equip it for use in the vacuum and extreme temperatures of space. The modifications included a change of lubricants for the camera and a thermal protective covering.

A flash unit also is available for use. The flash has been modified to remain in an air-tight housing for use in the vacuum of space.

Digital images taken during a spacewalk are stored in the memory of the camera and later brought back inside the shuttle cabin. Then, they are fed into a laptop computer in the cabin and transmitted to Mission Control. The digital EVA camera may be used to provide images of an inflight repair performed during a mission, to assist an EVA inspection of potential damage or for other reasons.

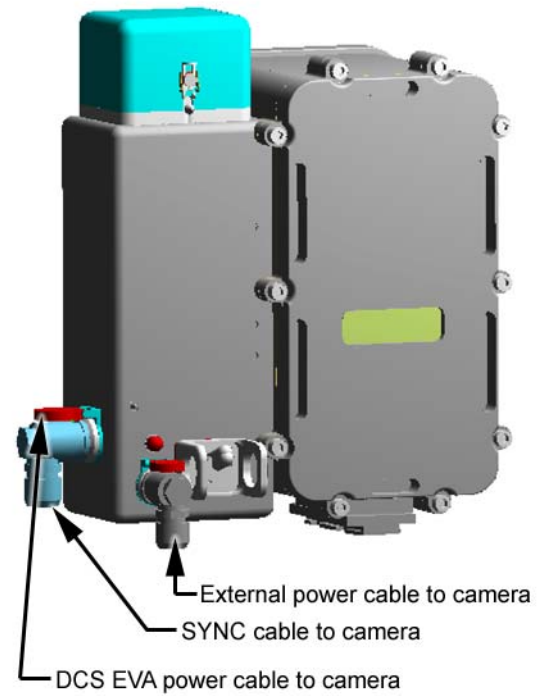

RTF\_VI\_008.png

**EVA Flash Mechanical Design**





# IN-FLIGHT INSPECTION AND REPAIR

In addition to improved cameras on the ground and on the space shuttle, Discovery's astronauts will conduct close-up, in-flight inspections with cameras, lasers, and human eyes.

The primary tool for on-orbit inspection will be a 50-foot-long space shuttle robotic arm extension and associated sensors, known as the Orbiter Boom Sensor System (OBSS). While the shuttle's remote manipulator system (SRMS) is capable of inspecting part of the thermal protection system on its own, the OBSS is used to extend that reach to all critical areas of the shuttle's wing leading edge and underside.

The OBSS was assembled by MD Robotics of Brampton, Ontario, Canada, which manufactures remote manipulator systems for

both the shuttle and the International Space Station. The OBSS combines two 20-foot-long graphite epoxy cylinders originally manufactured as shuttle arm replacement parts. At one end of the boom is a modified electrical grapple fixture, and on the other end are the imagery systems.

The two sections are joined by a rigid fixture, which has an attached modified flight releasable grapple fixture that will be used to hand the boom from the station arm to the shuttle arm during docked operation at the complex. Electrical and data cables run the length of the boom, providing power for the sensors while allowing imagery to be transferred through the shuttle's wiring system to laptop computers and downlink systems in the crew cabin.

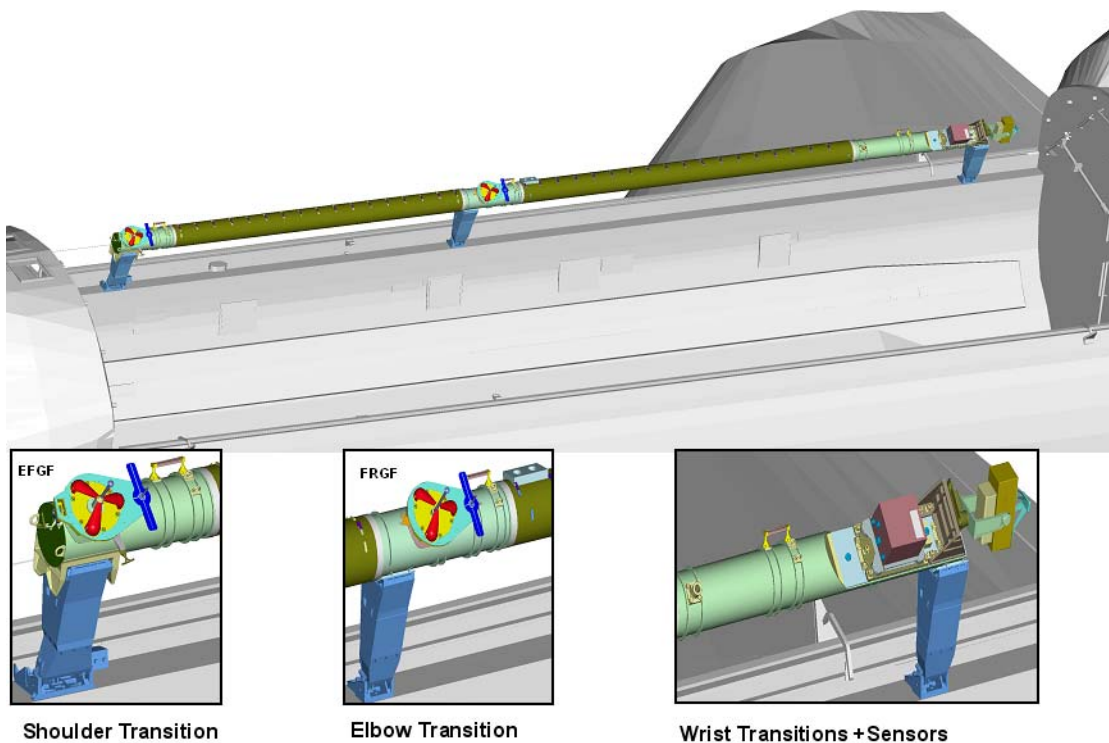

**Orbiter Boom Sensor System Installed on Starboard Sill**

The imagery systems include a laser dynamic range imager (LDRI), a laser camera system (LCS) and an intensified television camera (ITVC). The LDRI and ITVC are attached to the boom using a standard Pan Tilt Unit (PTU) for pointing. The LCS is hard-mounted to the side of the boom just behind the other two instruments.

Manufactured by Sandia National Laboratories, Albuquerque, N.M., the LDRI is comprised of an infrared (not visible to the human eye) laser illuminator and an infrared camera receiver. The LDRI can be used to provide either two- or three-dimensional video imagery data; the two-dimensional imagery may be seen by the shuttle crew on orbit, but three-dimensional data will need to be processed on the ground after being downlinked via the shuttle's high-bandwidth Ku antenna system that transmits the video through the Tracking and Data Relay Satellite System (TDRSS).

The ITVC is the same low-light, black-and-white television camera used in the space shuttle's payload bay. The two imagery systems may not be used simultaneously.

The LCS, manufactured by Neptec of Ottawa, Ontario, Canada, is a scanning laser range finder developed for use aboard the Space Shuttle. The LCS can be used as a 3D camera or to generate computer models of the scanned objects, accurate to a few millimeters at distances of up to 10 meters. Unlike the LDRI, the LCS data is not video, but instead are files collected on a dedicated laptop.

For STS-121, another digital camera has been added to the boom's sensor package. This Integrated Sensor Inspection System Digital Camera (IDC) is packaged with the Laser Camera System and offers high enough resolution to see minute damage on the wing leading edge panels. It is designed to help

distinguish "brown spots" and gap fillers as were seen during inspections on STS-114 last July.

The data is processed on the ground after being downlinked through the orbital communications adapter (OCA) - a high-speed computer modem that uses the Shuttle's Ku antenna system to transmit the data through the TDRSS.

Discovery is scheduled to rendezvous and dock with the International Space Station on flight day 3. As the shuttle pursues the station on flight day 2, the crew will conduct a thorough inspection of Discovery's wing leading edges and nose cone using the OBSS. Three crew members will take turns, working in pairs, to operate the shuttle's robotic arm from the aft flight deck, unberth the OBSS from its cradles on the starboard side of the payload bay and conduct the inspection.

Since the LDRI and LCS must remain within 10 feet of its target to ensure image quality and because the arm and boom must not contact any of the shuttle's surfaces in the process, the astronauts use a combination of automated and manual arm operation modes. The surveys are done using automatic mode with the astronauts monitoring its progress. The astronauts will use the manual arm operation mode to move the OBSS from the end of one sequence to the start of the next.

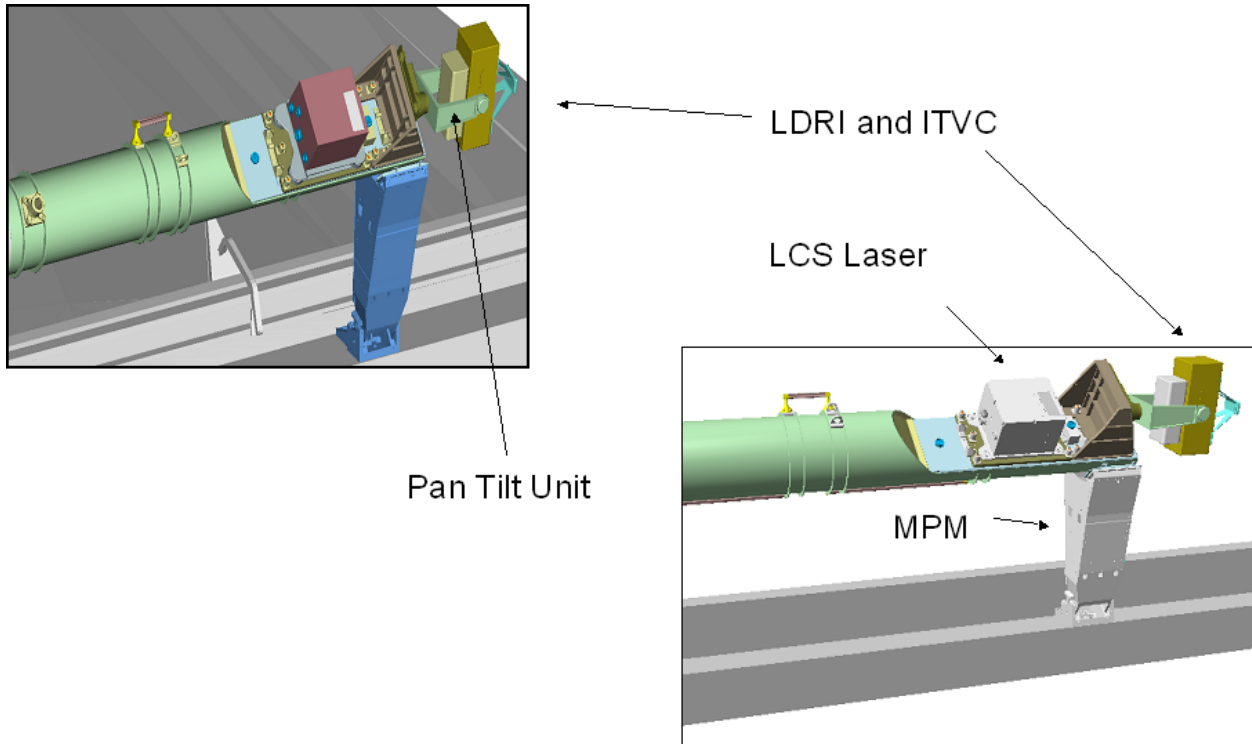

Inspection Sensors

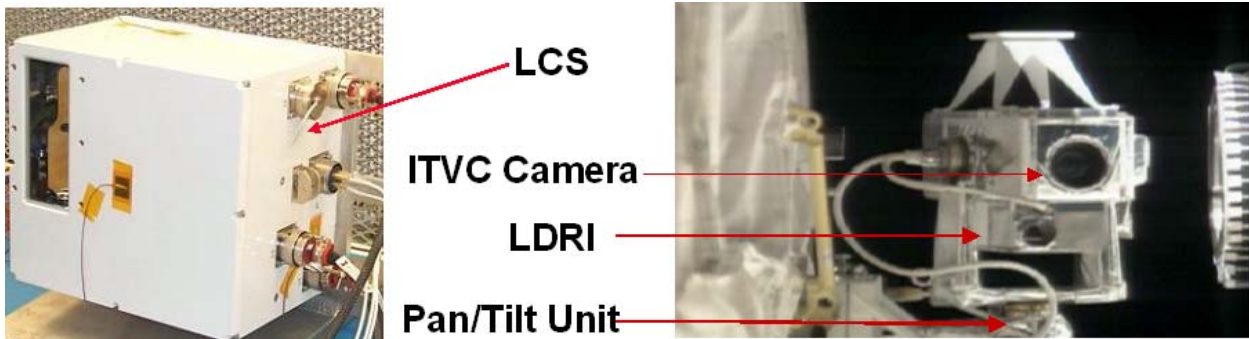

- Neptec Laser Camera System (LCS)
- Triangulates 3D position with a small diameter scanning laser beam
- Sandia Laser Dynamic Range Imager (LDRI)

- Illuminates the FOV with modulated laser light. Images on a camera CCD are processed to provide depth information.
- Designed & flown as an integrated package with an ITVC and pan & tilt unit (PTU)

Mission planners expect the flight day 2 survey of Discovery's wing leading edges and nose cap to take about seven hours to complete, assuming a maximum scan rate of four meters per minute (2½ inches per second). The scans will be broken into 60- to 90-minute blocks, or sequences, corresponding with specific areas of the shuttle's thermal protection skin.

Engineering experts on the ground will review the data both in real time and after processing on the ground to identify any areas that need additional scrutiny.

Discovery's robotic arm is expected to be used without the boom on flight day 2 to conduct video inspections of the upper tile surfaces using the arm's end effector camera. The next day, during the shuttle's rendezvous with the station, as Discovery reaches a point 600 feet below the station, the crew will perform a rendezvous pitch maneuver, a three-quarter-foot per-second backflip, so that its underside faces the station. The station crew will use digital still cameras with 400 and 800 millimeter lenses and a detailed plan to photographically map the shuttle's underside for about 90 seconds before it continues on to docking. The images will be sent to Earth for inclusion in the collection of data that will be used by the Mission Evaluation Room (MER) and Mission Management Team (MMT) to evaluate the condition of the thermal protection system. That data will be part of the compilation of imagery to allow mission managers to make decisions on how the mission should proceed.

After docking and welcome ceremonies are complete, shuttle and station crew members will work together, lifting the OBSS out of the cargo bay using the space station remote manipulator system (SSRMS) and handing it to the shuttle arm for use in additional surveys the following day. The station arm, also known as

Canadarm2, will be brought into play because the geometry of the combined shuttle-station configuration results in obstructions that prevent the shuttle arm from maneuvering the OBSS out of its cargo bay cradles. The flight plan identifies flight day 4 as an additional day for docked surveys, if required, using the OBSS, either to complete parts of the survey that time would not allow on flight day 2, or to supplement the survey with "stop-and-stare" scans of sites of potential interest. Some of Discovery's crew will reserve time for these detailed inspections for the last half of flight day 4 while other crew members are making preparations for the first spacewalk, which will, among other things, test thermal protection system inspection and repair capabilities.

Additional inspections of the orbiter wing leading edges and nose cap prior to deorbit and landing to detect Micrometeoroid Orbital Debris (MMOD) damage has been made a high priority by the Space Shuttle Program. These so-called "late inspections" using the OBSS will be conducted during STS-121. The survey of the port wing will be conducted the day before Discovery undocks from the space station. The starboard wing and nose cap will be inspected immediately after undocking. The sensor data will be downlinked to the ground for evaluation.

After the in-flight data, images and personal reports from the crew are relayed to the ground, engineers and imagery experts will process and integrate the information with that recorded during launch and the climb to orbit. The Space Shuttle Program's Systems Engineering and Integration Office (SE&I) will work closely with the MER to review and evaluate the information and provide separate damage assessments for tiles and the reinforced carbon-carbon panels of the wing leading edges and nose cap.

## THERMAL PROTECTION SYSTEM ON-ORBIT REPAIR TECHNIQUES

Prevention is NASA's first line of defense against damage to the space shuttle's thermal protection system (TPS). Minimizing cannot eliminate all the threats to the shuttle's tiles and reinforced carbon-carbon wing leading edge panels. Orbital debris (or space junk) and micrometeoroids also are capable of causing damage.

Experts from the TPS engineering, mission operations and extravehicular activity organizations at JSC, working in collaboration with their counterparts at other NASA centers and with contractors, identified the issues that needed to be addressed, and devised means of addressing them. Preliminary criteria for damage that must be repaired on orbit was defined, identifying all critical areas that must be reached for inspection, identifying candidate on-orbit repair materials capable of withstanding the stress of entry, and design initial tools and techniques that would allow spacewalkers to repair critical damage to both tiles and reinforced carbon-carbon segments.

The TPS repair systems developed to date fall into two basic categories, mechanical or chemical. Each type has advantages and disadvantages. Mechanical systems rely on prefabricated materials and fasteners that connect them to the shuttles' existing protection systems. Chemical systems rely on materials that are applied in a raw form and develop a chemical adhesive bond when applied to the existing protection systems; these must cure in place before being subjected to re-entry conditions. Mechanical installation methods can be tested and validated on Earth, while chemical methods require testing in space to validate application techniques and material hardening.

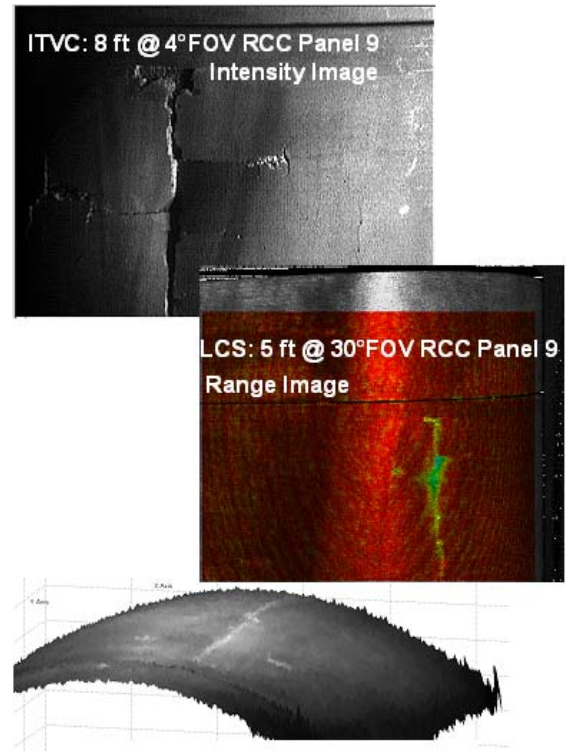

- ITVC
- Good flexibility as a general survey tool
- Low resolution, inherent image defects
- Able to detect small defects under specific conditions
- LCS
- Provides very detailed 3-dimensional information
- Shown to operate while translating
- LDRI
- Valuable performance as both a 2D & 3D imager
- Picture shows an intensity image laid on top of range image, although it appears fuzzy to the untrained eye, it gives a wealth of data

The crack repair option uses a pre-ceramic polymer sealant impregnated with carbon-silicon carbide powder, together known as NOAX (short for Non-Oxide Adhesive eXperimental). It is designed to fix the most likely type of damage caused by small pieces of foam coming off the external tank. NOAX can be used at any RCC location, and does not require any physical modification of the RCC before affecting a repair. A selection of hand tools similar to putty knives would be used to work the material into the crack and to smooth the surface of the repair.

## ACCESS

Access to damaged sites will be accomplished through a variety of means, depending on whether the shuttle is at the International Space Station.

On station missions, techniques are being developed that will allow robotic arm operators to undock and reposition the shuttle for a

station-based spacewalk repair. Spacewalkers would be positioned at the work site by the station's robotic arm using a portable articulating foot restraint (PAFR).

For non-station missions, access may be gained through the use of the shuttle's robotic arm or the arm and its 50-foot boom extension, which is being tested on EVA 1 during STS-121, or through use of the shuttle aid for extravehicular rescue (SAFER). A variety of candidate work platforms are in preliminary stages of development and continue to be evaluated.

## FUTURE WORK

Several other repair concepts have been proposed for both tile and RCC repair. These include flexible adhesive patches and small area repair plugs for RCC, and hardening of the existing tile system coating. Researchers at a variety of NASA centers and contractor laboratories are continuing to develop these approaches for possible future use.

# IMAGERY AND DATA COLLECTION FOR SPACE SHUTTLE LAUNCH AND LANDING

Documenting the space shuttle launches includes a minimum of three different views from ground sites as well as aircraft-based video. These additional views and cameras provide much higher fidelity footage for assessing whether any debris came off the external tank during the first two minutes of flight when the vehicle encounters the highest aerodynamic loads. A total of 107 ground and aircraft-based cameras will document Discovery's launch and climb to orbit.

The ground camera ascent imagery system was upgraded following the Columbia accident and also will include ship and ground-based radar to compliment the strategically placed cameras. In place for launch will be upgraded cameras and high definition television (HDTV) for quick look analysis, and mirrored server capability to more easily and quickly allow the sharing of imagery between KSC, JSC, and Marshall.

## GROUND-BASED IMAGING OF LAUNCH

The three camera sites are designated one, two and six. Site one, northeast of the launch pad, ensures a view of the underside of the right wing as well as the area between the external tank and the orbiter to track any debris during its roll maneuver just after launch. All sites have two film and one HDTV video cameras.

The short-range tracking cameras have 200mm focal length lenses and are loaded with 400 feet of film, running 100 frames per second. In addition to the film cameras around the launch pads, there are 42 fixed cameras with 16mm motion picture film.

TYPE	NO.	
Infrared (IR)	2	
High Speed Digital Video (HSDV)	2	
70 mm	3	
High Definition (HDTV)	19	
National Television Standards Committee (NTSC)	20	
35 mm	29	
16 mm	32	
<b>TOTAL</b>	<b>107</b>	

LOCATION	TYPE	NO.
Launch Pad 39B (Launch platform & launch tower)	16 mm	30
Launch Pad Perimeter	16 mm	2
	35 mm	5
Short Range Tracking Sites (3)	HDTV	3
	35 mm	6
Medium Range Tracking Sites (6)	70 mm	1
	NTSC	1
	HSDV	2
	35 mm	7
	HDTV	6
Long Range Tracking Sites (11)	70 mm	2
	NTSC	4
	HDTV	5
	35 mm	11
WB-57 Aircraft (2)	Infrared	2
	HDTV	2
Operational Television (OTV)	HDTV	3
	NTSC	9
Public Affairs	NTSC	6
<b>TOTAL</b>		<b>107</b>



Medium-range trackers are at six sites, three along the coast and three near the Launch Complex 39 area. They provide three views for triangulation, to better characterize any suspect area. These cameras have 800mm and greater lenses, and can capture 100 frames per second. Three of the cameras have 400 feet of film and two have 1,000 feet. The additional tracking cameras have 150-inch lenses, with 1,000 feet of film. Five of six sites also have HDTV video cameras.

Five long-range trackers have existed north and south of the pads, from Shiloh and Playalinda to Cocoa Beach, ranging from 14 miles north to 20 miles south. These additions will reach as far north as Ponce de Leon Inlet, 38 miles from the launch pads, and south to Pigor, 11 miles from the pads. One of the cameras previously located at Patrick Air Force Base has been converted to be transportable and moved north of the pad.

All the cameras have 400-inch focal length and 100 feet per second capability to provide more data points to better track any debris.

Two of the cameras are part of the distant object attitude measurement system (DOAMS), located at Playalinda Beach and the Cocoa Beach area. A refurbished five-meter focal length telescope has been installed in the Cocoa Beach location. Each of these sites also will have HDTV video cameras.

A unique feature of the tracking telescopes is a robotic camera manned by a technician sitting on top and manipulating a joystick to map the shuttle's track through the sky.





## CAMERAS

A variety of cameras and lenses are used to support ascent imaging, including film and digital cameras.

- 35mm film cameras are used at the pad and on short, medium and long range camera sites and provide the highest resolution dictating they are the primary imagery to meet the minimum size requirements for debris identification during ascent.
- HDTV digital video cameras are co-located with many of the 35mm cameras and provide quick look capability. The digital video data provides the ability to conduct expedited post-launch imagery processing and review (quick look) before the film is processed and distributed.
- National Television Standards Committee (NTSC) – backup sites without HDTV.
- 70mm motion picture film cameras provide “big sky” views.
- 16mm motion picture film cameras are used on the Mobile Launch Platform and Fixed Service Structure of the launch pad.
- Other cameras throughout the launch pad perimeter and other locations provide additional quick look views.

Cameras are either fixed or mounted on a tracker. A variety of trackers are used, the predominant being a Kineto Tracking Mount (KTM) tracker. All of the trackers near the launch pads are remotely controlled. The remaining trackers are remotely or manually controlled on-site.



**Kineto Tracking Mount tracker**

## CAMERA LOCATIONS

The ascent ground cameras provide imagery from the launch platform and on the launch tower itself, as well as from short, medium and long-range sites as mentioned above.

Twenty-two 16mm cameras are on the Mobile Launch Platform...

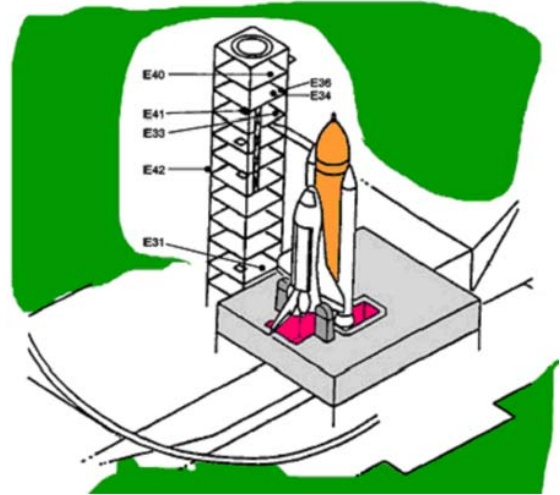

RTF\_IV\_13.png

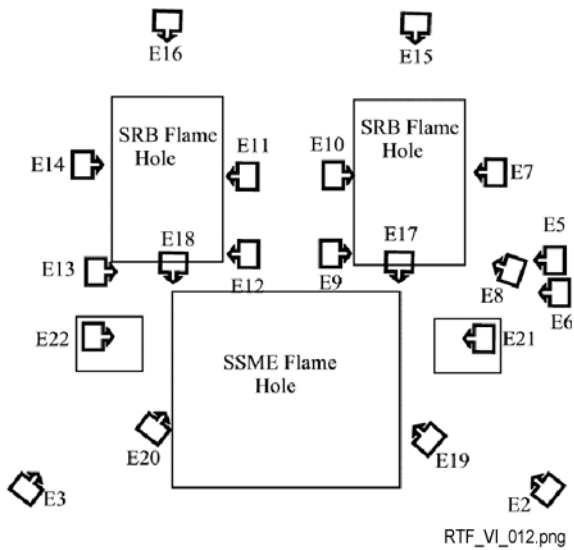

RTF\_VI\_012.png

...and eight 16mm cameras are on the launch tower (Fixed Service Structure).

The three short-range camera sites are within the pad perimeter approximately 422 to 432 yards from the launch pads and include two 35mm cameras and an HDTV camera. These sites provide coverage during the early phases of a launch to image individual portions of the shuttle stack. Once the vehicle clears the launch tower, these cameras can capture larger portions of the shuttle, but lose the ability to image and track small debris.

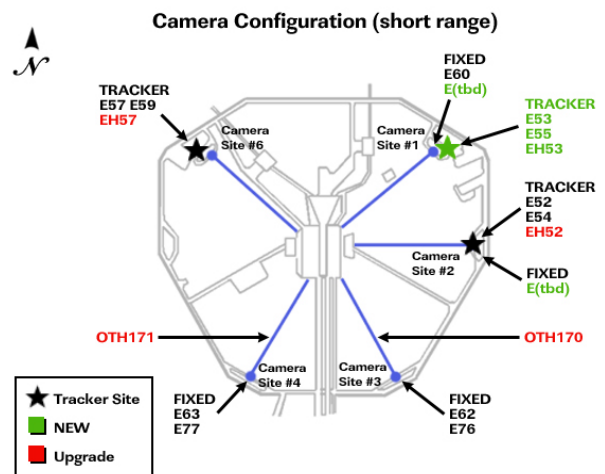

Eleven medium-range sites are one to six miles from the launch pads—seven used for Pad 39A and six for Pad 39B. The medium-range sites each have a 35mm camera while 10 of the 11 incorporate HDTV cameras. Medium-range

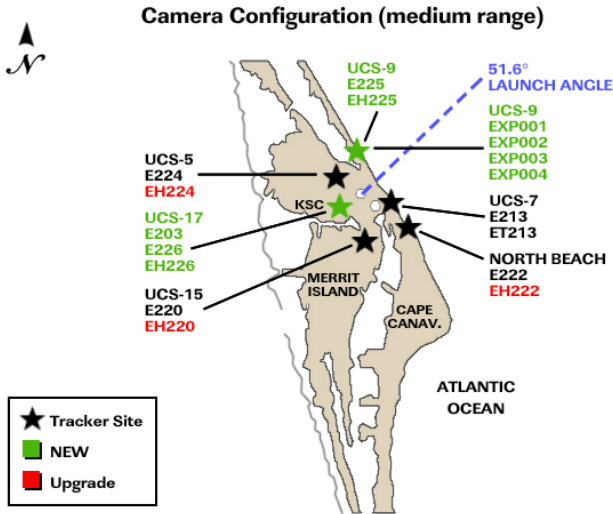

cameras are used from the early phase of ascent until the distance to the shuttle becomes too far to identify and track debris.

Eleven long-range sites are located 4 to almost 40 miles from the launch pads, and support both pads. All these sites have 35mm cameras, and two have 70mm cameras. Five of the 10 sites have HDTV cameras. Long-range cameras are used during early phases of ascent to identify and track debris and continue to be used as long as the vehicle is visible.

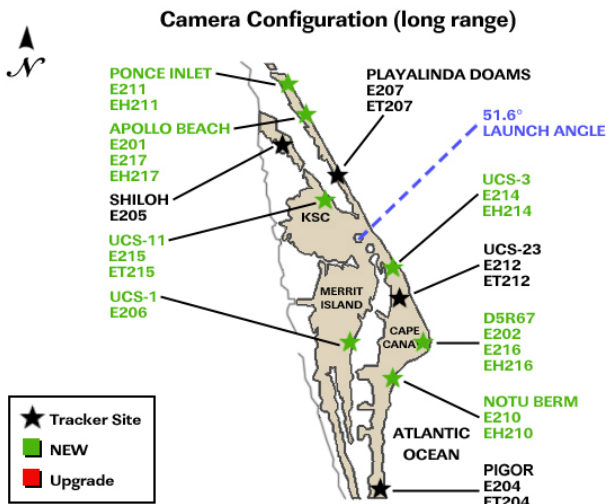

## CAMERA RESOLUTION

- Liftoff to 30 seconds: Objects of 1 inch in diameter or larger, 0.5 foot linear accuracy of debris source and impact location
- 30 seconds to 60 seconds: Objects of 3 inches in diameter or larger, 1 foot linear accuracy of debris source and impact location
- 60 seconds to 90 seconds: Objects of 8 inches in diameter or larger, 3 foot linear accuracy of debris source and impact location
- 90 seconds to booster separation: Objects of 15 inches in diameter or larger, 5 foot linear accuracy of debris source and impact location

## CAMERA OPERATIONS PLAN

All of the cameras are checked pre-launch, and then activated on launch day to capture the ascent imagery. After launch, the 70mm, 35mm and 16mm films are collected and taken to a central location at the Kennedy Space Center. Then they are flown to a processing facility to be developed and copied for delivery to the Johnson Space Center in Houston and the Marshall Space Flight Center in Huntsville, Ala. The delivery occurs in two steps, one the day after launch and the second two days after launch.

The quick look video imagery—HDTV and other formats—is collected and distributed within the first few hours after launch and provided to the image analysis facilities at Kennedy, Johnson and Marshall via a mirrored server available for review between one and eight hours after launch.

About one hour after launch, the quick look imagery consists primarily of views from the short-range cameras and is reviewed by all of the imagery analysis teams. Quick look imagery consisting of HDTV imagery from the medium and long-range sites will be retrieved and made available to the imagery analysis teams and thermal protection system experts approximately eight hours after launch.

## ASCENT IMAGING FROM ABOVE

NASA has implemented an aircraft-based imaging system using agency WB-57 aircraft based near the Johnson Space Center in Houston. The WB-57 ascent video experiment (WAVE) will be used again to provide ascent and entry imagery to enable better observation of the shuttle on days of heavier cloud cover and areas obscured from ground cameras by the launch exhaust plume. WAVE was initiated as a return to flight capability to develop the technical and operational capabilities of obtaining video of the shuttle during launch from an aircraft, which will supplement ground cameras to obtain three useful views.



**WB-57 Aircraft**

WAVE includes a 32-inch ball turret system mounted on the nose of each WB-57. The turret houses an optical bench providing installation for both high definition television and infrared cameras. Optics consists of an 11-inch diameter, 4.2 meter fixed focal length lens. The system can be operated in both auto track and manual modes from a command and control system in the cockpit, which includes monitors for all three cameras, switch panels and

joysticks. All footage will be recorded on board and returned for processing and evaluation shortly after the shuttle launch.

The two imaging cameras are a HDTV color camera (Panasonic AK-HC900) and a near infrared camera (Sensors Unlimited SU640SDV 1.7RT/RS-170). Both share a Celestron fixed field-of-view telescopic lens. In addition, a National Television Standards Committee (NTSC) color acquisition camera will be used during ascent.

Two days before launch the two WB-57s will fly from Ellington Field in Houston to Patrick Air Force Base in Florida.

Two and a half hours before launch, the aircraft will take off from Patrick and enter a holding pattern. One will be positioned north and one south of the shuttle's flight path. They will be in communication with a WAVE Operations Officer in the Range Operations Control Center who in turn will be in communication with the chairperson of the imagery team in the Launch Control Center.



**SRB Separation**

Twenty minutes before launch the aircraft will enter their final circuit, and about five minutes before launch will begin recording video. The WAVE requirement is for imagery acquisition from 60 seconds after liftoff to 15 seconds after

booster separation. However, plans are for the aircraft to track the vehicle from liftoff through main engine cutoff (MECO), 8½ minutes later. The two aircraft should be about 23 miles (37 kilometers) from the shuttle at booster separation.

After launch, the aircraft will return to Patrick, and the video will be taken to Kennedy. There it will be loaded on the mirrored servers about eight hours later.

The WB-57 aircraft operate under direction of JSC. They are the only two WB-57s still flying. Identified as NASA 926 and NASA 928, the high-altitude weather aircraft can fly day and night with a range of 2,500 miles. Two crew members in pressurized suits pilot the plane to altitudes in excess of 60,000 feet. They can carry a payload of about 6,000 pounds.

## RADAR TRACKING

A new wideband and Doppler radar tracking system has been implemented for adequate detection of debris during launch and ascent. Three radars now will digitally record tracking data of the shuttle from launch until signal is lost with the primary timeframe of interest being launch plus 60 seconds to launch plus two minutes.

Data from each radar site will be stored on a hard disk and backed up on CDs/DVDs, as will be the boresight video used by the radar operators to help track the vehicle.

The three radar systems that launch will be in place for one C-band and two Doppler X-band radar systems.

The Wideband Coherent C-band Radar provides high spatial resolution of debris events, and can detect debris events within the



**The 50-foot, C-band radar located at the NDR-1 site north of the Kennedy Space Center**

Shuttle vehicle stack. This radar—called the Navy Midcourse Radar—formerly was located at Roosevelt Roads Naval Station in Puerto Rico.

The two Weibel Continuous Pulse Doppler X-band Radars provide velocity and differential shuttle/debris motion information. Correlation of these two data sets over the three geometries provided for the debris radar system optimizes the insight and probability of detection for very faint debris targets. These radar systems will be located on ships—one on a booster recovery ship downrange of the launch site and the other on a ship south of the ground track.

The radars are capable of resolving debris at or greater than observed signal strength of minus 50 decibels per square meter (dBsm). Shuttle debris sources have been characterized as typically falling within in the minus 30 dBsm to minus 45 dBsm range. The X-band and the C-band radars were flight tested during the launch of Discovery in July 2005 and for three expendable rocket launches site from the NASA Debris Radar (NDR-1) intended to permanently house the systems.



**NASA X-band radar on the fantail of "Freedom Star" - one of two solid rocket booster recovery ships**

The radar data will be analyzed at the NDR-1 site with the C-band data being available in near real-time, while the X-band data (screen captures) will be sent from the ships via satellite link to the site. The southern ship is expected back in port 6 hours after launch, and the data will be transported immediately.

## **WING LEADING EDGE INSTRUMENTATION**

NASA chose to incorporate sensors along the orbiter wing leading edges to compliment thermal protection system inspection by measuring, recording, and transmitting acceleration data to a laptop computer on the flight deck for early transmission to the Mission Control Center.

The Wing Leading Edge Impact Detection System (WLEIDS) is comprised of 88 sensors embedded behind the protective reinforced carbon carbon panels. Sixty six acquire acceleration data and 22 gather temperature measurements during the shuttle's launch phase. The temperature sensor data is used to calibrate the impact sensors.

Battery-powered sensor units inside the wing will measure, record and transmit acceleration and temperature data, along with battery voltage to the laptop computer via a combination of radio relays and cables.

Before launch, the sensor units are loaded with command files that contain the Greenwich Mean Time (GMT) of launch. Shortly before liftoff, the units start taking accelerometer data at 20,000 samples per second per channel and the launch vibrations cause the units to begin storing the data in internal memory. New for STS-121, the sensors will be activated preflight to measure vibration from countdown milestones such as auxiliary power unit start-up and the gimbal checks of the three space shuttle main engines. This data can be used to verify the margin on the launch triggers (settings used to initiate data collection when WLEIDS senses liftoff) to avoid premature start of data storage. Temperature and battery voltage data is stored every 15 seconds.

Ten minutes after launch—after the external tank separates—continuous data collection will stop. Each sensor unit will process the data to determine the peak acceleration forces that particular sensor experienced during ascent. These summary data files, which are more quickly downlinked to the ground than the huge volume of raw data, will be screened to determine whether any potential impact events occurred. Since STS-114, the analysis team has refined its procedures on how to standardize and automate the analysis in order to produce an ascent report as soon as 18–24 hours after launch.

Any measured ascent impacts will be ranked in order of importance for the focused inspection (if required) based on the best measure of impact energy. Since this is only the second flight of the WLEIDS, the data will not

necessarily relate to risk of damage, but will continue to build the database required to validate models in the future.

After processing the data, the system will enter on-orbit mode, meaning only six sensor units (2 on each wing) will collect acceleration, temperature and battery voltage. The other units will become idle. The specific units in each mode will rotate throughout the flight in order to maximize the battery life of the sensors.

About 1½ hours after launch, the crew will connect the wing leading edge system laptop to the onboard computer network and the software will begin to download data from each sensor unit. Commands are sent through the laptop to the 44 sensor units and will download acceleration, temperature and voltage data for each sensor to designated folders on the laptop and, new for STS-121, the designated backup laptop on the LAN.

A small amount of raw data from liftoff also will be downloaded to be used as a baseline for calculations on the ground. Throughout the remainder of the flight, the sensor units will be commanded every six hours to download G-force peaks, time of occurrence, voltage and temperature files.

As an STS-121 detailed test objective, the wing leading edge impact detection system will

investigate its on orbit monitoring capability for micrometeoroid debris (MMOD) detection as long as battery life permits. Future potential software enhancements could increase the on-orbit battery life and the ability to detect small MMOD impacts based on data collected during this, and future flights.

As the data files are written to the laptop, they will be extracted from the laptop via ground control by operators in Mission Control and placed on a server for access and evaluation by experts. The back-up laptop will allow WLEIDS operations to continue in case the crew is not available to reset the primary laptop in the event of a fault.

Based on the data evaluation of summary data, additional raw data will be requested for each potential impact or data event of interest. Raw data can also be requested based on findings from telemetry or other imagery sources. A command will download the specific time period needed for further evaluation. Data from each sensor unit is downloaded at a rate equivalent to two minutes for ½ second of raw data to the laptop, so a complete set of raw data will not be downloaded to the laptop.

After landing, ground operations personnel at Kennedy Space Center will download the remaining raw data for archival and analysis.

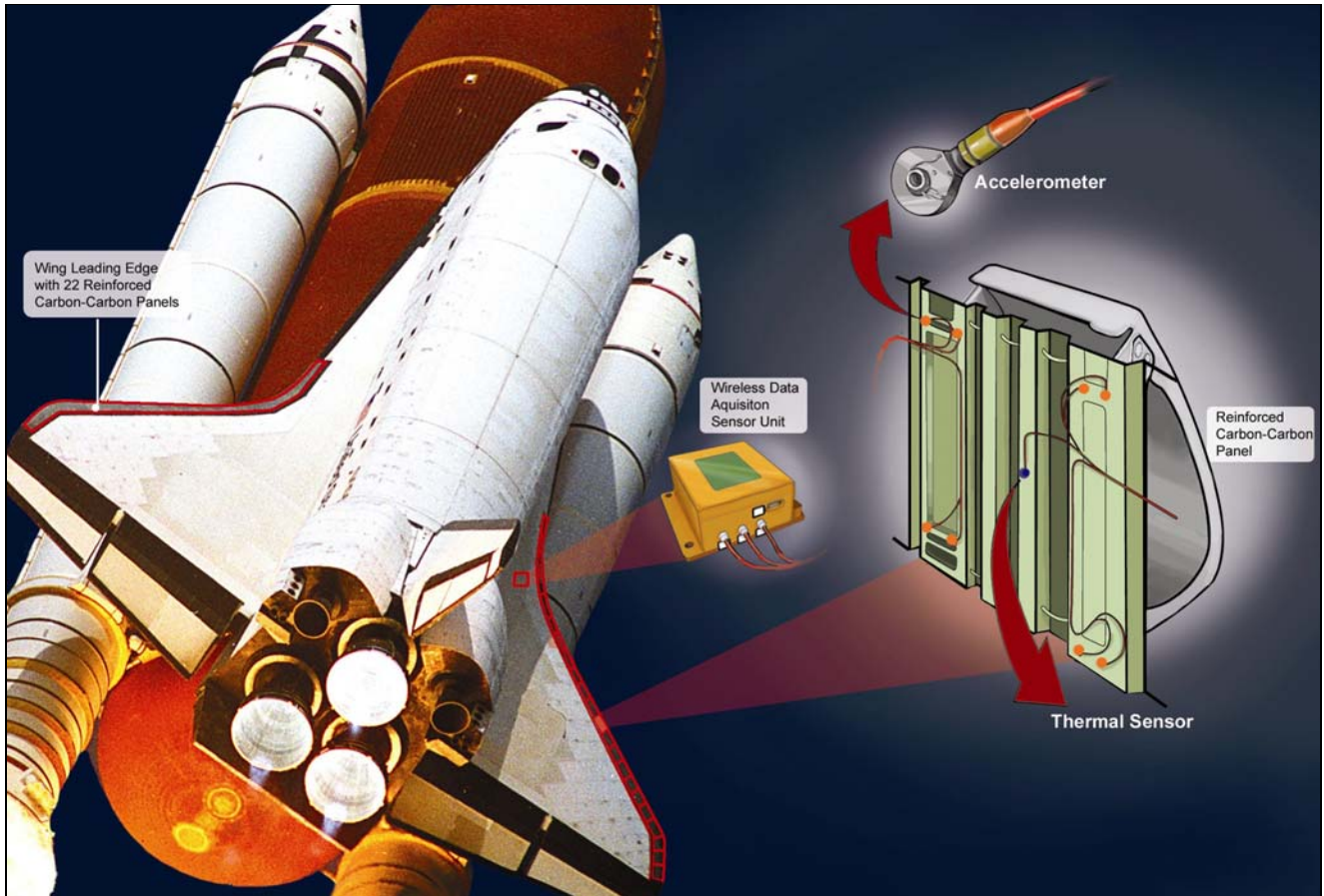

Wing Leading Edge Impact Detection System



## WING LEADING EDGE IMPACT DETECTION SYSTEM

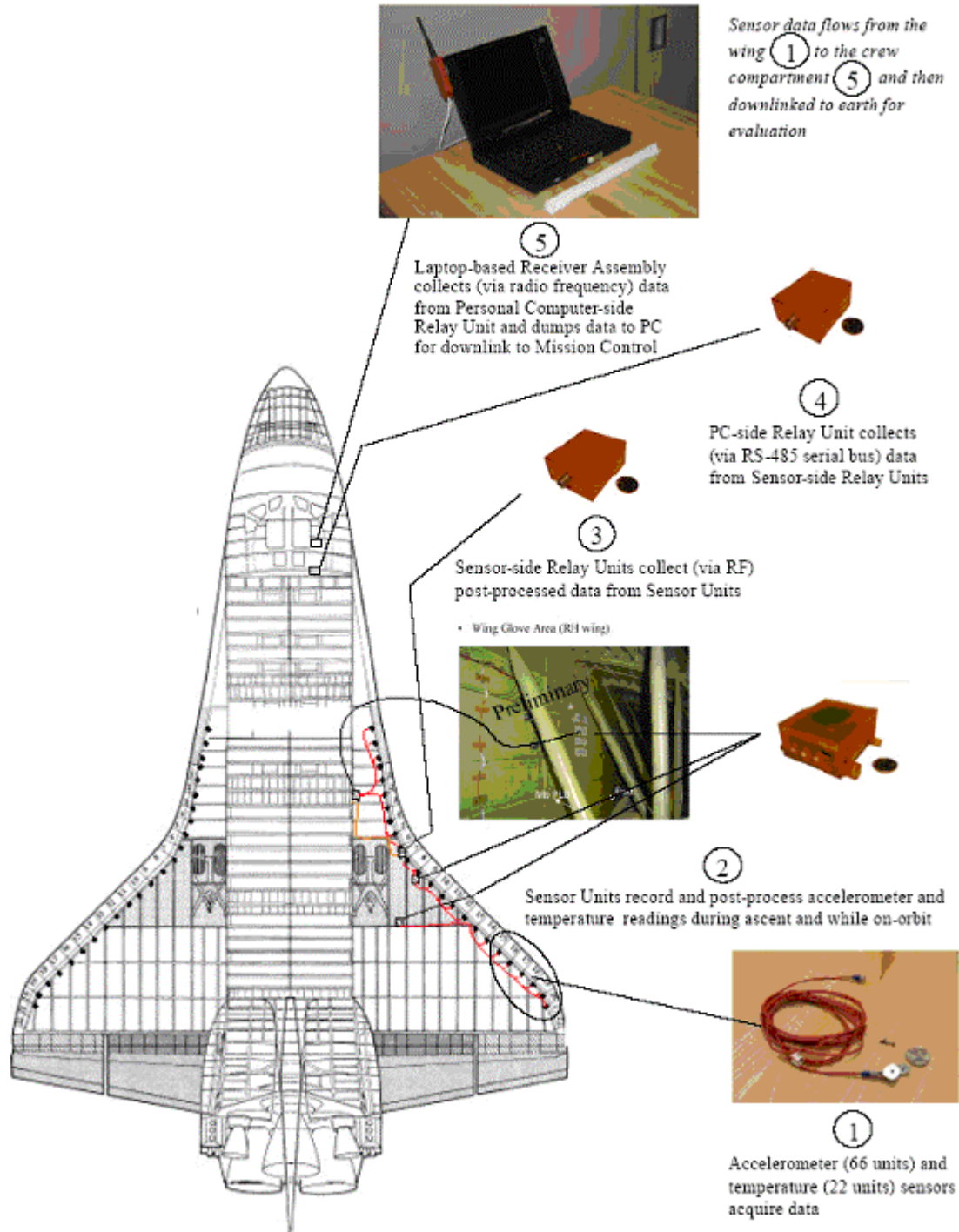



## TILE REPAIR ABLATOR DISPENSER (T-RAD)

NASA engineers have designed the Tile Repair Ablator Dispenser or T-RAD as part of the ongoing development of an in-orbit repair capability for the Space Shuttle. Similar to a caulk-gun, the T-RAD was designed to facilitate the repair of tiles near the orbiter's nose landing gear door, its two main landing gear doors and the external tank attachment doors.

Should tiles in those areas be damaged, an Extra-Vehicular Activity (EVA) crew member will use T-RAD to mix and extrude a two-part silicone-based ablator material into the void in the tile and then work it in smoothly.

The silicone-based material, known as Shuttle Tile Ablator-54 (STA-54), consists of a base material and a catalyst. Once mixed, it resembles the consistency of cake-frosting. However, the material cures to the texture of a pencil eraser within 24 to 48 hours. During re-entry, the STA-54 dissipates heat by charring, thus protecting the shuttle tiles.

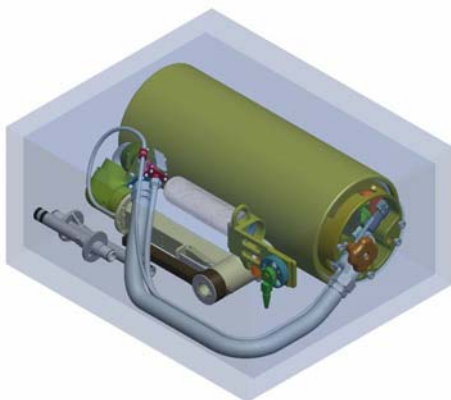

### Tile Repair Ablator Dispenser (T-RAD)

The T-RAD is comprised of a single, carbon dioxide-pressurized vessel separated into two main sections. Its mixing, delivery system consists of a static mixer, a 3-foot length of hose

and an applicator gun that controls the flow of the extruding material. The assembly weighs 55 pounds and is about the same size as a hand-held vacuum.

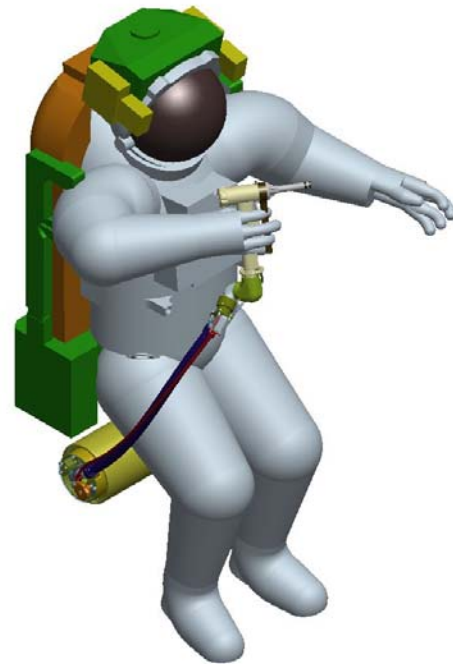

### T-RAD Delivery System

T-RAD replaces the Cure-In-Place Ablative Applicator (CIPAA) that flew on STS-114. The more cumbersome CIPAA system consisted of an EVA backpack with tanks that held the base and catalyst components under pressure, and paired hoses to transport the components to the damaged area. The applicator gun that CIPAA used has been incorporated directly into the T-RAD design.

The T-RAD will not be tested on the STS-121 mission, it is being carried for contingency use if, for some reason, the ISS safe-haven option were unavailable. It also will be manifested on space shuttle flights STS-115 and STS-116 for contingency use.



## CONTINGENCY SHUTTLE CREW SUPPORT (CSCS)

NASA initiated a study to determine the feasibility of rescuing a stranded space shuttle crew at the International Space Station (ISS) in the unlikely event damage would prevent the safe re-entry of the vehicle. The ISS Program conducted an extensive evaluation of the station's capability to provide provisions and life support to a shuttle crew as part of an agency self-imposed contingency case that would ensure a second shuttle was far enough along in processing to be launched to rescue the stranded crew.

This contingency shuttle crew support (CSCS)—also known as safe haven—would be used only as a last resort to return the crew of a critically damaged shuttle. In the unlikely event all new safety measures were unsuccessful, and a shuttle docked to the ISS is deemed unsafe for return to Earth, NASA would consider using CSCS to rescue the crew.

The ISS and Space Shuttle Programs have made the necessary preparations for this option to be available for the next two shuttle flights (STS-121 & STS-115). The Programs will continue to evaluate the capability to enact CSCS for future flights.

Those preparations include investigating ways to appropriately build up critical systems and consumables onboard the station.

The CSCS scenario allows the visiting crew of a critically damaged shuttle to live onboard the space station until a rescue shuttle can be launched. The crews would transfer all of the consumables from the damaged shuttle to the station. Once the shuttle consumables are depleted, the unmanned shuttle will be remotely commanded to undock by Mission Control in Houston and burn up in the Earth's atmosphere.

In the meantime, the next space shuttle in the launch processing flow at the Kennedy Space Center in Florida will become the rescue vehicle and work will focus on it launching and arriving at the station before consumables run out. The number of days the station can support a stranded shuttle crew would be determined, in part, by the consumables already on board, plus what is brought up with the shuttle. The level of consumables onboard the station, including food, water, oxygen and spare parts, will be reviewed and provided up until the day of the first shuttle launch to define the CSCS capability for that particular mission.

NASA's plan of crew support in a contingency calls for a subset of the STS-115 crew to support STS-121 and a subset of the STS-116 crew to support STS-115. The contingency flights are designated STS-300 and STS-301, respectively. The crew members that would support a CSCS case are:

### STS-300

Brent Jett, commander

Chris Ferguson, pilot and backup Remote Manipulator System operator

Joe Tanner, mission specialist 1, Extravehicular 1 and prime Remote Manipulator System operator

Dan Burbank, mission specialist 2 and Extravehicular 2

The Soyuz spacecraft at the space station will remain the emergency rescue vehicle for the ISS Expedition crew.

### STS-301

Mark Polansky, commander and prime Remote Manipulator System operator

Bill Oefelein, pilot and backup Remote Manipulator System operator

Bob Curbeam, mission specialist 1, Extravehicular 1

Christer Fuglesang, mission specialist 2, Extravehicular 2

Detailed biographies on the astronauts are available at: <http://www.jsc.nasa.gov/Bios/>

# SHUTTLE REFERENCE DATA

## SHUTTLE ABORT MODES

### RSLs Aborts

These occur when the on-board shuttle computers detect a problem and command a halt in the launch sequence after taking over from the ground launch sequencer and before solid rocket booster ignition.

### Ascent Aborts

Selection of an ascent abort mode may become necessary if there is a failure that affects vehicle performance, such as the failure of a space shuttle main engine or an orbital maneuvering system. Other failures requiring early termination of a flight, such as a cabin leak, might also require the selection of an abort mode. There are two basic types of ascent abort modes for space shuttle missions: intact aborts and contingency aborts. Intact aborts are designed to provide a safe return of the orbiter to a planned landing site. Contingency aborts are designed to permit flight crew survival following more severe failures when an intact abort is not possible. A contingency abort would generally result in a ditch operation.

### Intact Aborts

There are four types of intact aborts: abort to orbit (ATO), abort once around (AOA), transoceanic abort landing (TAL) and return to launch site (RTLs).

### Return to Launch Site

The RTLs abort mode is designed to allow the return of the orbiter, crew and payload to the

launch site, Kennedy Space Center, approximately 25 minutes after liftoff.

The RTLs profile is designed to accommodate the loss of thrust from one space shuttle main engine between liftoff and approximately four minutes 20 seconds, at which time not enough main propulsion system propellant remains to return to the launch site. An RTLs can be considered to consist of three stages—a powered stage, during which the space shuttle main engines are still thrusting; an external tank separation phase; and the glide phase, during which the orbiter glides to a landing at the Kennedy Space Center. The powered RTLs phase begins with the crew selection of the RTLs abort, which is done after solid rocket booster separation. The crew selects the abort mode by positioning the abort rotary switch to RTLs and depressing the abort push button. The time at which the RTLs is selected depends on the reason for the abort. For example, a three-engine RTLs is selected at the last moment, about 3 minutes, 34 seconds into the mission; whereas an RTLs chosen due to an engine out at liftoff is selected at the earliest time, about 2 minutes, 20 seconds into the mission (after solid rocket booster separation).

After RTLs is selected, the vehicle continues downrange to dissipate excess main propulsion system propellant. The goal is to leave only enough main propulsion system propellant to be able to turn the vehicle around, fly back toward the Kennedy Space Center and achieve the proper main engine cutoff conditions so the vehicle can glide to the Kennedy Space Center after external tank separation. During the downrange phase, a pitch-around maneuver is

initiated (the time depends in part on the time of a space shuttle main engine failure) to orient the orbiter/external tank configuration to a heads-up attitude, pointing toward the launch site. At this time, the vehicle is still moving away from the launch site, but the space shuttle main engines are now thrusting to null the downrange velocity. In addition, excess orbital maneuvering system and reaction control system propellants are dumped by continuous orbital maneuvering system and reaction control system engine thrustings to improve the orbiter weight and center of gravity for the glide phase and landing.

The vehicle will reach the desired main engine cutoff point with less than 2 percent excess propellant remaining in the external tank. At main engine cutoff minus 20 seconds, a pitch down maneuver (called powered pitch-down) takes the mated vehicle to the required external tank separation attitude and pitch rate. After main engine cutoff has been commanded, the external tank separation sequence begins, including a reaction control system translation that ensures that the orbiter does not recontact the external tank and that the orbiter has achieved the necessary pitch attitude to begin the glide phase of the RTLS.

After the reaction control system translation maneuver has been completed, the glide phase of the RTLS begins. From then on, the RTLS is handled similarly to a normal entry.

### **Transoceanic Abort Landing**

The TAL abort mode was developed to improve the options available when a space shuttle main engine fails after the last RTLS opportunity but before the first time that an AOA can be accomplished with only two space shuttle main engines or when a major orbiter system failure, for example, a large cabin pressure leak or cooling system failure, occurs

after the last RTLS opportunity, making it imperative to land as quickly as possible.

In a TAL abort, the vehicle continues on a ballistic trajectory across the Atlantic Ocean to land at a predetermined runway. Landing occurs about 45 minutes after launch. The landing site is selected near the nominal ascent ground track of the orbiter to make the most efficient use of space shuttle main engine propellant. The landing site also must have the necessary runway length, weather conditions and U.S. State Department approval. The three landing sites that have been identified for a due east launch are Zaragoza, Spain; Moron, Spain; and Istres, France.

To select the TAL abort mode, the crew must place the abort rotary switch in the TAL/AOA position and depress the abort push button before main engine cutoff. (Depressing it after main engine cutoff selects the AOA abort mode.) The TAL abort mode begins sending commands to steer the vehicle toward the plane of the landing site. It also rolls the vehicle heads up before main engine cutoff and sends commands to begin an orbital maneuvering system propellant dump (by burning the propellants through the orbital maneuvering system engines and the reaction control system engines). This dump is necessary to increase vehicle performance (by decreasing weight), to place the center of gravity in the proper place for vehicle control and to decrease the vehicle's landing weight. TAL is handled like a nominal entry.

### **Abort to Orbit**

An ATO is an abort mode used to boost the orbiter to a safe orbital altitude when performance has been lost and it is impossible to reach the planned orbital altitude. If a space shuttle main engine fails in a region that results in a main engine cutoff under speed, the



Mission Control Center will determine that an abort mode is necessary and will inform the crew. The orbital maneuvering system engines would be used to place the orbiter in a circular orbit.

### **Abort Once Around**

The AOA abort mode is used in cases in which vehicle performance has been lost to such an extent that either it is impossible to achieve a viable orbit or not enough orbital maneuvering system propellant is available to accomplish the orbital maneuvering system thrusting maneuver to place the orbiter on orbit and the deorbit thrusting maneuver. In addition, an AOA is used in cases in which a major systems problem (cabin leak, loss of cooling) makes it necessary to land quickly. In the AOA abort mode, one orbital maneuvering system thrusting sequence is made to adjust the post-main engine cutoff orbit so a second orbital maneuvering system thrusting sequence will result in the vehicle deorbiting and landing at the AOA landing site (White Sands, N.M.; Edwards Air Force Base; or the Kennedy Space Center). Thus, an AOA results in the orbiter circling the Earth once and landing about 90 minutes after liftoff.

After the deorbit thrusting sequence has been executed, the flight crew flies to a landing at the planned site much as it would for a nominal entry.

### **Contingency Aborts**

Contingency aborts are caused by loss of more than one main engine or failures in other systems. Loss of one main engine while another is stuck at a low thrust setting may also necessitate a contingency abort. Such an abort would maintain orbiter integrity for in-flight crew escape if a landing cannot be achieved at a suitable landing field.

Contingency aborts due to system failures other than those involving the main engines would normally result in an intact recovery of vehicle and crew. Loss of more than one main engine may, depending on engine failure times, result in a safe runway landing. However, in most three-engine-out cases during ascent, the orbiter would have to be ditched. The inflight crew escape system would be used before ditching the orbiter.

### **Abort Decisions**

There is a definite order of preference for the various abort modes. The type of failure and the time of the failure determine which type of abort is selected. In cases where performance loss is the only factor, the preferred modes would be ATO, AOA, TAL and RTLS, in that order. The mode chosen is the highest one that can be completed with the remaining vehicle performance.

In the case of some support system failures, such as cabin leaks or vehicle cooling problems, the preferred mode might be the one that will end the mission most quickly. In these cases, TAL or RTLS might be preferable to AOA or ATO. A contingency abort is never chosen if another abort option exists.

Mission Control Houston is prime for calling these aborts because it has a more precise knowledge of the orbiter's position than the crew can obtain from on-board systems. Before main engine cutoff, Mission Control makes periodic calls to the crew to tell them which abort mode is (or is not) available. If ground communications are lost, the flight crew has on-board methods, such as cue cards, dedicated displays and display information, to determine the abort region.

Which abort mode is selected depends on the cause and timing of the failure causing the

abort and which mode is safest or improves mission success. If the problem is a space shuttle main engine failure, the flight crew and Mission Control Center select the best option available at the time a main engine fails.

If the problem is a system failure that jeopardizes the vehicle, the fastest abort mode that results in the earliest vehicle landing is chosen. RTLS and TAL are the quickest options (35 minutes), whereas an AOA requires about 90 minutes. Which of these is selected depends on the time of the failure with three good space shuttle main engines.

The flight crew selects the abort mode by positioning an abort mode switch and depressing an abort push button.

## SHUTTLE ABORT HISTORY

### **RSLs Abort History: (STS-41 D) June 26, 1984**

The countdown for the second launch attempt for Discovery's maiden flight ended at T-4 seconds when the orbiter's computers detected a sluggish valve in main engine No. 3. The main engine was replaced and Discovery was finally launched on Aug. 30, 1984.

### **(STS-51 F) July 12, 1985**

The countdown for Challenger's launch was halted at T-3 seconds when on-board computers detected a problem with a coolant valve on main engine No. 2. The valve was replaced and Challenger was launched on July 29, 1985.

### **(STS-55) March 22, 1993**

The countdown for Columbia's launch was halted by on-board computers at T-3 seconds following a problem with purge pressure readings in the oxidizer preburner on main

engine No. 2. Columbia's three main engines were replaced on the launch pad, and the flight was rescheduled behind Discovery's launch on STS-56. Columbia finally launched on April 26, 1993.

### **(STS-51) Aug. 12, 1993**

The countdown for Discovery's third launch attempt ended at the T-3 second mark when onboard computers detected the failure of one of four sensors in main engine No. 2 which monitor the flow of hydrogen fuel to the engine. All of Discovery's main engines were ordered replaced on the launch pad, delaying the shuttle's fourth launch attempt until Sept. 12, 1993.

### **(STS-68) Aug. 18, 1994**

The countdown for Endeavour's first launch attempt ended 1.9 seconds before liftoff when on-board computers detected higher than acceptable readings in one channel of a sensor monitoring the discharge temperature of the high pressure oxidizer turbopump in main engine No. 3. A test firing of the engine at the Stennis Space Center in Mississippi on September 2nd confirmed that a slight drift in a fuel flow meter in the engine caused a slight increase in the turbopump's temperature. The test firing also confirmed a slightly slower start for main engine No. 3 during the pad abort, which could have contributed to the higher temperatures. After Endeavour was brought back to the Vehicle Assembly Building to be outfitted with three replacement engines, NASA managers set Oct. 2 as the date for Endeavour's second launch attempt.

### **Abort to Orbit History: (STS-51 F) July 29, 1985**

After an RSLs abort on July 12, 1985, Challenger was launched on July 29, 1985. Five

minutes and 45 seconds after launch, a sensor problem resulted in the shutdown of center engine No. 1, resulting in a safe "abort to orbit" and successful completion of the mission.

## SPACE SHUTTLE MAIN ENGINES

Developed in the 1970s by NASA's Marshall Space Flight Center in Huntsville, Ala., the space shuttle main engine is the most advanced liquid-fueled rocket engine ever built. Its main features include variable thrust, high performance, reusability, high redundancy and a fully integrated engine controller.

The shuttle's three main engines are mounted on the orbiter aft fuselage in a triangular pattern. Spaced so that they are movable during launch, the engines are used – in conjunction with the solid rocket boosters – to steer the shuttle vehicle.

Each of these powerful main engines is 14 feet (4.2 meters) long, weighs about 7,000 pounds (3,150 kilograms) and is 7.5 feet (2.25 meters) in diameter at the end of its nozzle.

The engines operate for about 8½ minutes during liftoff and ascent—burning more than 500,000 gallons (1.9 million liters) of super-cold liquid hydrogen and liquid oxygen propellants stored in the huge external tank attached to the underside of the shuttle. The engines shut down just before the shuttle, traveling at about 17,000 mph (28,000 kilometers per hour), reaches orbit.

The main engine operates at greater temperature extremes than any mechanical system in common use today. The fuel, liquefied hydrogen at -423 degrees Fahrenheit (-253 degrees Celsius), is the second coldest liquid on Earth. When it and the liquid oxygen are combusted, the temperature in the main combustion chamber is 6,000 degrees

Fahrenheit (3,316 degrees Celsius), hotter than the boiling point of iron.

The main engines use a staged combustion cycle so that all propellants entering the engines are used to produce thrust or power—more efficiently than any previous rocket engine. In a staged combustion cycle, propellants are first burned partially at high pressure and relatively low temperature—then burned completely at high temperature and pressure in the main combustion chamber. The rapid mixing of the propellants under these conditions is so complete that 99 percent of the fuel is burned.

At normal operating level, the engines generate 490,847 pounds of thrust (measured in a vacuum). Full power is 512,900 pounds of thrust; minimum power is 316,100 pounds of thrust.

The engine can be throttled by varying the output of the pre-burners, thus varying the speed of the high-pressure turbopumps and, therefore, the flow of the propellant.

At about 26 seconds into launch, the main engines are throttled down to 316,000 pounds of thrust to keep the dynamic pressure on the vehicle below a specified level—about 580 pounds per square foot or max q. Then, the engines are throttled back up to normal operating level at about 60 seconds. This reduces stress on the vehicle.

The main engines are throttled down again at about seven minutes, 40 seconds into the mission to maintain three g's – three times the Earth's gravitational pull – again reducing stress on the crew and the vehicle. This acceleration level is about one-third the acceleration experienced on previous crewed space vehicles.

About 10 seconds before main engine cutoff or MECO, the cutoff sequence begins; about three seconds later the main engines are commanded to begin throttling at 10 percent thrust per second to 65 percent thrust. This is held for about 6.7 seconds, and the engines are shut down.

The engine performance has the highest thrust for its weight of any engine yet developed. In fact, one space shuttle main engine generates sufficient thrust to maintain the flight of 2½ 747 airplanes.

The space shuttle main engine is also the first rocket engine to use a built-in electronic digital controller, or computer. The controller will accept commands from the orbiter for engine start, change in throttle, shutdown, and monitor engine operation. In the event of a failure, the controller automatically corrects the problem or safely shuts down the engine.

NASA continues to increase the reliability and safety of shuttle flights through a series of enhancements to the space shuttle main engines. The engines were modified in 1988, 1995, 1998 and 2001. Modifications include new high-pressure fuel and oxidizer turbopumps that reduce maintenance and operating costs of the engine, a two-duct powerhead that reduces pressure and turbulence in the engine, and a single-coil heat exchanger that lowers the number of post flight inspections required. Another modification incorporates a large-throat main combustion chamber that improves the engine's reliability by reducing pressure and temperature in the chamber.

After the orbiter lands, the engines are removed and returned to a processing facility at Kennedy Space Center, Fla., where they are rechecked and readied for the next flight. Some components are returned to the main engine's prime contractor, Rocketdyne Propulsion &

Power unit of the Boeing Company, Canoga Park, Calif., for regular maintenance. The main engines are designed to operate for 7.5 accumulated hours.

## SPACE SHUTTLE SOLID ROCKET BOOSTERS

The two SRBs provide the main thrust to lift the space shuttle off the pad and up to an altitude of about 150,000 feet, or 24 nautical miles (28 statute miles). In addition, the two SRBs carry the entire weight of the external tank and orbiter and transmit the weight load through their structure to the mobile launcher platform.

Each booster has a thrust (sea level) of about 3,300,000 pounds at launch. They are ignited after the three space shuttle main engines' thrust level is verified. The two SRBs provide 71.4 percent of the thrust at liftoff and during first-stage ascent. Seventy-five seconds after SRB separation, SRB apogee occurs at an altitude of about 220,000 feet, or 35 nautical miles (40 statute miles). SRB impact occurs in the ocean about 122 nautical miles (140 statute miles) downrange.

The SRBs are the largest solid-propellant motors ever flown and the first designed for reuse. Each is 149.16 feet long and 12.17 feet in diameter.

Each SRB weighs about 1,300,000 pounds at launch. The propellant for each solid rocket motor weighs about 1,100,000 pounds. The inert weight of each SRB is about 192,000 pounds.

Primary elements of each booster are the motor (including case, propellant, igniter and nozzle), structure, separation systems, operational flight instrumentation, recovery avionics, pyrotechnics, deceleration system, thrust vector

control system and range safety destruct system.

Each booster is attached to the external tank at the SRB's aft frame by two lateral sway braces and a diagonal attachment. The forward end of each SRB is attached to the external tank at the forward end of the SRB's forward skirt. On the launch pad, each booster also is attached to the mobile launcher platform at the aft skirt by four bolts and nuts that are severed by small explosives at liftoff.

During the downtime following the Challenger accident, detailed structural analyses were performed on critical structural elements of the SRB. Analyses were primarily focused in areas where anomalies had been noted during postflight inspection of recovered hardware.

One of the areas was the attach ring where the SRBs are connected to the external tank. Areas of distress were noted in some of the fasteners where the ring attaches to the SRB motor case. This situation was attributed to the high loads encountered during water impact. To correct the situation and ensure higher strength margins during ascent, the attach ring was redesigned to encircle the motor case completely (360 degrees).

Previously, the attach ring formed a C and encircled the motor case 270 degrees.

Additionally, special structural tests were done on the aft skirt. During this test program, an anomaly occurred in a critical weld between the hold-down post and skin of the skirt. A redesign was implemented to add reinforcement brackets and fittings in the aft ring of the skirt.

These two modifications added about 450 pounds to the weight of each SRB.

The propellant mixture in each SRB motor consists of an ammonium perchlorate (oxidizer, 69.6 percent by weight), aluminum (fuel, 16 percent), iron oxide (a catalyst, 0.4 percent), a polymer (a binder that holds the mixture together, 12.04 percent), and an epoxy curing agent (1.96 percent). The propellant is an 11-point star-shaped perforation in the forward motor segment and a double-truncated-cone perforation in each of the aft segments and aft closure. This configuration provides high thrust at ignition and then reduces the thrust by about a third 50 seconds after liftoff to prevent overstressing the vehicle during maximum dynamic pressure.

The SRBs are used as matched pairs and each is made up of four solid rocket motor segments. The pairs are matched by loading each of the four motor segments in pairs from the same batches of propellant ingredients to minimize any thrust imbalance. The segmented-casing design assures maximum flexibility in fabrication and ease of transportation and handling. Each segment is shipped to the launch site on a heavy-duty rail car with a specially built cover.

The nozzle expansion ratio of each booster beginning with the STS-8 mission is 7-to-79. The nozzle is gimballed for thrust vector (direction) control. Each SRB has its own redundant auxiliary power units and hydraulic pumps. The all-axis gimbaling capability is 8 degrees. Each nozzle has a carbon cloth liner that erodes and chars during firing. The nozzle is a convergent-divergent, movable design in which an aft pivot-point flexible bearing is the gimbal mechanism.

The cone-shaped aft skirt reacts the aft loads between the SRB and the mobile launcher platform. The four aft separation motors are mounted on the skirt. The aft section contains

avionics, a thrust vector control system that consists of two auxiliary power units and hydraulic pumps, hydraulic systems and a nozzle extension jettison system.

The forward section of each booster contains avionics, a sequencer, forward separation motors, a nose cone separation system, drogue and main parachutes, a recovery beacon, a recovery light, a parachute camera on selected flights and a range safety system.

Each SRB has two integrated electronic assemblies, one forward and one aft. After burnout, the forward assembly initiates the release of the nose cap and frustum, a transition piece between the nose cone and solid rocket motor, and turns on the recovery aids. The aft assembly, mounted in the external tank/SRB attach ring, connects with the forward assembly and the orbiter avionics systems for SRB ignition commands and nozzle thrust vector control. Each integrated electronic assembly has a multiplexer/demultiplexer, which sends or receives more than one message, signal or unit of information on a single communication channel.

Eight booster separation motors (four in the nose frustum and four in the aft skirt) of each SRB thrust for 1.02 seconds at SRB separation from the external tank. Each solid rocket separation motor is 31.1 inches long and 12.8 inches in diameter.

Location aids are provided for each SRB, frustum/drogue chutes and main parachutes. These include a transmitter, antenna, strobe/converter, battery and salt-water switch electronics. The location aids are designed for a minimum operating life of 72 hours and when refurbished are considered usable up to 20 times. The flashing light is an exception. It has an operating life of 280 hours. The battery is used only once.

The SRB nose caps and nozzle extensions are not recovered.

The recovery crew retrieves the SRBs, frustum/drogue chutes, and main parachutes. The nozzles are plugged, the solid rocket motors are dewatered, and the SRBs are towed back to the launch site. Each booster is removed from the water, and its components are disassembled and washed with fresh and deionized water to limit salt-water corrosion. The motor segments, igniter and nozzle are shipped back to ATK Thiokol for refurbishment.

Each SRB incorporates a range safety system that includes a battery power source, receiver/decoder, antennas and ordnance.

### **Hold-Down Posts**

Each solid rocket booster has four hold-down posts that fit into corresponding support posts on the mobile launcher platform. Hold-down bolts hold the SRB and launcher platform posts together. Each bolt has a nut at each end, but only the top nut is frangible. The top nut contains two NASA standard detonators (NSDs), which are ignited at solid rocket motor ignition commands.

When the two NSDs are ignited at each hold-down, the hold-down bolt travels downward because of the release of tension in the bolt (pretensioned before launch), NSD gas pressure and gravity. The bolt is stopped by the stud deceleration stand, which contains sand. The SRB bolt is 28 inches long and 3.5 inches in diameter. The frangible nut is captured in a blast container.

The solid rocket motor ignition commands are issued by the orbiter's computers through the master events controllers to the hold-down pyrotechnic initiator controllers on the mobile

launcher platform. They provide the ignition to the hold-down NSDs. The launch processing system monitors the SRB hold-down PICs for low voltage during the last 16 seconds before launch. PIC low voltage will initiate a launch hold.

## SRB Ignition

SRB ignition can occur only when a manual lock pin from each SRB safe and arm device has been removed. The ground crew removes the pin during prelaunch activities. At T minus five minutes, the SRB safe and arm device is rotated to the arm position. The solid rocket motor ignition commands are issued when the three SSMEs are at or above 90 percent rated thrust, no SSME fail and/or SRB ignition PIC low voltage is indicated and there are no holds from the LPS.

The solid rocket motor ignition commands are sent by the orbiter computers through the MECs to the safe and arm device NSDs in each SRB. A PIC single-channel capacitor discharge device controls the firing of each pyrotechnic device. Three signals must be present simultaneously for the PIC to generate the pyro firing output. These signals—arm, fire 1 and fire 2—originate in the orbiter general-purpose computers and are transmitted to the MECs. The MECs reformat them to 28-volt dc signals for the PICs. The arm signal charges the PIC capacitor to 40 volts dc (minimum of 20 volts dc).

The fire 2 commands cause the redundant NSDs to fire through a thin barrier seal down a flame tunnel. This ignites a pyro booster charge, which is retained in the safe and arm device behind a perforated plate. The booster charge ignites the propellant in the igniter initiator; and combustion products of this propellant ignite the solid rocket motor

initiator, which fires down the length of the solid rocket motor igniting the solid rocket motor propellant.

The GPC launch sequence also controls certain critical main propulsion system valves and monitors the engine-ready indications from the SSMEs. The MPS start commands are issued by the on-board computers at T minus 6.6 seconds (staggered start—engine three, engine two, engine one—all about within 0.25 of a second), and the sequence monitors the thrust buildup of each engine. All three SSMEs must reach the required 90 percent thrust within three seconds; otherwise, an orderly shutdown is commanded and safing functions are initiated.

Normal thrust buildup to the required 90 percent thrust level will result in the SSMEs being commanded to the liftoff position at T minus three seconds as well as the fire 1 command being issued to arm the SRBs. At T minus three seconds, the vehicle base bending load modes are allowed to initialize (movement of 25.5 inches measured at the tip of the external tank, with movement towards the external tank).

At T minus zero, the two SRBs are ignited under command of the four on-board computers; separation of the four explosive bolts on each SRB is initiated (each bolt is 28 inches long and 3.5 inches in diameter); the two T-0 umbilicals (one on each side of the spacecraft) are retracted; the on-board master timing unit, event timer and mission event timers are started; the three SSMEs are at 100 percent; and the ground launch sequence is terminated.

The solid rocket motor thrust profile is tailored to reduce thrust during the maximum dynamic pressure region.

## Electrical Power Distribution

Electrical power distribution in each SRB consists of orbiter-supplied main dc bus power to each SRB via SRB buses A, B and C. Orbiter main dc buses A, B and C supply main dc bus power to corresponding SRB buses A, B and C. In addition, orbiter main dc bus C supplies backup power to SRB buses A and B, and orbiter bus B supplies backup power to SRB bus C. This electrical power distribution arrangement allows all SRB buses to remain powered in the event one orbiter main bus fails.

The nominal dc voltage is 28 volts dc, with an upper limit of 32 volts dc and a lower limit of 24 volts dc.

## Hydraulic Power Units

There are two self-contained, independent HPUs on each SRB. Each HPU consists of an auxiliary power unit, fuel supply module, hydraulic pump, hydraulic reservoir and hydraulic fluid manifold assembly. The APUs are fueled by hydrazine and generate mechanical shaft power to a hydraulic pump that produces hydraulic pressure for the SRB hydraulic system. The two separate HPUs and two hydraulic systems are located on the aft end of each SRB between the SRB nozzle and aft skirt. The HPU components are mounted on the aft skirt between the rock and tilt actuators. The two systems operate from T minus 28 seconds until SRB separation from the orbiter and external tank. The two independent hydraulic systems are connected to the rock and tilt servoactuators.

The APU controller electronics are located in the SRB aft integrated electronic assemblies on the aft external tank attach rings.

The APUs and their fuel systems are isolated from each other. Each fuel supply module

(tank) contains 22 pounds of hydrazine. The fuel tank is pressurized with gaseous nitrogen at 400 psi, which provides the force to expel (positive expulsion) the fuel from the tank to the fuel distribution line, maintaining a positive fuel supply to the APU throughout its operation.

The fuel isolation valve is opened at APU startup to allow fuel to flow to the APU fuel pump and control valves and then to the gas generator. The gas generator's catalytic action decomposes the fuel and creates a hot gas. It feeds the hot gas exhaust product to the APU two-stage gas turbine. Fuel flows primarily through the startup bypass line until the APU speed is such that the fuel pump outlet pressure is greater than the bypass line's. Then all the fuel is supplied to the fuel pump.

The APU turbine assembly provides mechanical power to the APU gearbox. The gearbox drives the APU fuel pump, hydraulic pump and lube oil pump. The APU lube oil pump lubricates the gearbox. The turbine exhaust of each APU flows over the exterior of the gas generator, cooling it, and is then directed overboard through an exhaust duct.

When the APU speed reaches 100 percent, the APU primary control valve closes, and the APU speed is controlled by the APU controller electronics. If the primary control valve logic fails to the open state, the secondary control valve assumes control of the APU at 112 percent speed.

Each HPU on an SRB is connected to both servoactuators on that SRB. One HPU serves as the primary hydraulic source for the servoactuator, and the other HPU serves as the secondary hydraulics for the servoactuator. Each servoactuator has a switching valve that allows the secondary hydraulics to power the actuator if the primary hydraulic pressure



drops below 2,050 psi. A switch contact on the switching valve will close when the valve is in the secondary position. When the valve is closed, a signal is sent to the APU controller that inhibits the 100 percent APU speed control logic and enables the 112 percent APU speed control logic. The 100 percent APU speed enables one APU/HPU to supply sufficient operating hydraulic pressure to both servoactuators of that SRB.

The APU 100 percent speed corresponds to 72,000 rpm, 110 percent to 79,200 rpm, and 112 percent to 80,640 rpm.

The hydraulic pump speed is 3,600 rpm and supplies hydraulic pressure of 3,050, plus or minus 50, psi. A high-pressure relief valve provides overpressure protection to the hydraulic system and relieves at 3,750 psi.

The APUs/HPUs and hydraulic systems are reusable for 20 missions.

## Thrust Vector Control

Each SRB has two hydraulic gimbal servoactuators: one for rock and one for tilt. The servoactuators provide the force and control to gimbal the nozzle for thrust vector control.

The space shuttle ascent thrust vector control portion of the flight control system directs the thrust of the three shuttle main engines and the two SRB nozzles to control shuttle attitude and trajectory during liftoff and ascent. Commands from the guidance system are transmitted to the ATVC drivers, which transmit signals proportional to the commands to each servoactuator of the main engines and SRBs. Four independent flight control system channels and four ATVC channels control six main engine and four SRB ATVC drivers, with

each driver controlling one hydraulic port on each main and SRB servoactuator.

Each SRB servoactuator consists of four independent, two-stage servovalves that receive signals from the drivers. Each servovalve controls one power spool in each actuator, which positions an actuator ram and the nozzle to control the direction of thrust.

The four servovalves in each actuator provide a force-summed majority voting arrangement to position the power spool. With four identical commands to the four servovalves, the actuator force-sum action prevents a single erroneous command from affecting power ram motion. If the erroneous command persists for more than a predetermined time, differential pressure sensing activates a selector valve to isolate and remove the defective servovalve hydraulic pressure, permitting the remaining channels and servovalves to control the actuator ram spool.

Failure monitors are provided for each channel to indicate which channel has been bypassed. An isolation valve on each channel provides the capability of resetting a failed or bypassed channel.

Each actuator ram is equipped with transducers for position feedback to the thrust vector control system. Within each servoactuator ram is a splashdown load relief assembly to cushion the nozzle at water splashdown and prevent damage to the nozzle flexible bearing.

## SRB Rate Gyro Assemblies

Each SRB contains two RGAs, with each RGA containing one pitch and one yaw gyro. These provide an output proportional to angular rates about the pitch and yaw axes to the orbiter computers and guidance, navigation and control system during first-stage ascent flight in

conjunction with the orbiter roll rate gyros until SRB separation. At SRB separation, a switchover is made from the SRB RGAs to the orbiter RGAs.

The SRB RGA rates pass through the orbiter flight aft multiplexers/ demultiplexers to the orbiter GPCs. The RGA rates are then mid-value-selected in redundancy management to provide SRB pitch and yaw rates to the user software. The RGAs are designed for 20 missions.

### **SRB Separation**

SRB separation is initiated when the three solid rocket motor chamber pressure transducers are processed in the redundancy management middle value select and the head-end chamber pressure of both SRBs is less than or equal to 50 psi. A backup cue is the time elapsed from booster ignition.

The separation sequence is initiated, commanding the thrust vector control actuators to the null position and putting the main propulsion system into a second-stage configuration (0.8 second from sequence initialization), which ensures the thrust of each SRB is less than 100,000 pounds. Orbiter yaw attitude is held for four seconds, and SRB thrust drops to less than 60,000 pounds.

The SRBs separate from the external tank within 30 milliseconds of the ordnance firing command.

The forward attachment point consists of a ball (SRB) and socket (ET) held together by one bolt. The bolt contains one NSD pressure cartridge at each end. The forward attachment point also carries the range safety system cross-strap wiring connecting each SRB RSS and the ET RSS with each other.

The aft attachment points consist of three separate struts: upper, diagonal and lower. Each strut contains one bolt with an NSD pressure cartridge at each end. The upper strut also carries the umbilical interface between its SRB and the external tank and on to the orbiter.

There are four booster separation motors on each end of each SRB. The BSMs separate the SRBs from the external tank. The solid rocket motors in each cluster of four are ignited by firing redundant NSD pressure cartridges into redundant confined detonating fuse manifolds.

The separation commands issued from the orbiter by the SRB separation sequence initiate the redundant NSD pressure cartridge in each bolt and ignite the BSMs to effect a clean separation.

### **SPACE SHUTTLE SUPER LIGHT WEIGHT TANK (SLWT)**

The super lightweight external tank (SLWT) made its first shuttle flight June 2, 1998, on mission STS-91. The SLWT is 7,500 pounds lighter than the standard external tank. The lighter weight tank allows the shuttle to deliver International Space Station elements (such as the service module) into the proper orbit.

The SLWT is the same size as the previous design. But the liquid hydrogen tank and the liquid oxygen tank are made of aluminum lithium, a lighter, stronger material than the metal alloy used for the shuttle's current tank. The tank's structural design has also been improved, making it 30 percent stronger and 5 percent less dense.

The SLWT, like the standard tank, is manufactured at Michoud Assembly, near New Orleans, by Lockheed Martin.

The 154-foot-long external tank is the largest single component of the space shuttle. It stands taller than a 15-story building and has a diameter of about 27 feet. The external tank holds over 530,000 gallons of liquid hydrogen

and liquid oxygen in two separate tanks. The hydrogen (fuel) and liquid oxygen (oxidizer) are used as propellants for the shuttle's three main engines.



## ACRONYMS AND ABBREVIATIONS

AA	Antenna Assembly
AAA	Avionics Air Assembly
AAC	Aft Access Closure
ABC	Audio Bus Coupler
ABOLT	Acquire Bolt
AC	Assembly Complete
ACBM	Active CBM
ACC	Aft Cargo Carrier
ACO	Assembly and Checkout Officer
ACS	Atmosphere Control System Attitude Control System
ACSM	ACS Moding
ACU	Arm Computer Unit
AD	Active Device Attachment Device
ADF	Air Diffuser
AEA	Antenna Electronics Assembly
AESD	Airlock External Stowage Devices
AFD	Aft Flight Deck
AGB	Adjustable Grapple Bar
AIO	Analog Input/Output
AO	Atomic Oxygen
AOA	Abort Once Around
AOH	Assembly Operations Handbook
AOP	Assembly Ops
APAS	Androgynous Peripheral Attachment System
APCU	Assembly Power Converter Unit
APDS	Androgynous Peripheral Docking System
APFR	Articulating Portable Foot Restraint
APM	Attached Pressurized Module
APPCM	Arm Pitch Plane Change Mode
APS	Automated Payload Switch Auxiliary Power Supply
AR	Atmosphere Revitalization
ARCU	American-to-Russian Converter Units
ARIS	Active Rack Isolation System
ARS	Air Revitalization System
ASCR	Assured Safe Crew Return
ASDA	Area Smoke Detector Assembly

ASL	Atmosphere Sampling Line
ATA	Ammonia Tank Assembly
ATCS	Active Thermal Control System
ATU	Audio Terminal Unit
AUAI	Assemble Contingency System/UHF Audio Interface
AVU	Artificial Vision Unit
AVV	Accumulator Vent Valve
B/U	Backup
BBC	Backup Control Unit
BC	Bus Controller
BCDU	Battery Charge/Discharge Unit
BCU	Backup Control Unit Bus Controller Unit
BDU	Backup Drive Unit
BG	Beta Gimbal
BGA	Beta Gimbal Assembly
BGDTS	Beta Gimbal Deployment Transition Structure
BGHS	Beta Gimbal Housing Subassembly
BIT	Built-In Test
BITE	Built-In Test Equipment
BMRRM	Bearing Motor and Roll Ring Module
BPSMU	Battery-Powered Speaker Mike Unit
BRS	Bottom Right Side
BSP	Baseband Signal Processor
C&C	Command and Control
C&DH	Command and Data Handling
C&M	Control and Monitor
C&T	Command and Telemetry
	Communications and Tracking
C&W	Caution and Warning
C/L	Crew Lock
CA	Control Attitude
CAS	Common Attach System
CB	Control Bus
CBC-D2	Cross Bay Carrier—Deployable, Second Flight
CBC-ND	Cross Bay Carrier—Nondeployable
CBM	Common Berthing Mechanism
CCAA	Common Cabin Air Assembly
CCD	Cursor Control Device
CCMS	Concentric Cable Management System
CCS	Command and Communications Center
CCTV	Closed-Circuit Television
CDDT	Common Display Development Team

CDR	Commander
CDRA	Carbon Dioxide Removal Assembly
CDRS	Carbon Dioxide Removal System
CDS	Command and Data Software
CE	Cargo Element
CETA	Crew and Equipment Transportation Aid
CEU	Control Electronics Unit
CFA	Circulation Fan Assembly
CHeCS	Crew Health Care System
CHX	Condensing Heat Exchanger
CIPA	Cure-In-Place Ablator
CLA	Camera and Light Assembly
CMG	Control Moment Gyroscope
CMG-TA	Control Moment Gyroscope-Thruster Assist
COAS	Crew Optical Alignment Sight
COR	Communication Outage Recorder
COTS	Commercial-Off-The-Shelf
CP	Cold Plate
CR	Change Request
CRPCM	Canadian RPCM
CRT	Cathode Ray Tube
CSA	Canadian Space Agency
	Computer Systems Architecture
CSC	Computer Software Component
CSCI	Computer Software Configuration Item
CTB	Cargo Transfer Bag
CTBE	Cargo Transfer Bag Equivalents
CTVC	Color Television Camera
CVIU	Common Video Interface Unit
CVT	Current Value Table
CVV	Carbon Dioxide Vent Valve
CWC	Contingency Water Collection
DA	Depressurization Assembly
DAIU	Docked Audio Interface Unit
DAK	Double-Aluminized Kapton
DAP	Digital Autopilot
DC	Direct Current
DC-1	Docking Compartment-1
DCAM	Diffusion Controlled Apparatus for Microgravity
DCP	Display and Control Panel
DCSU	Direct Current Switching Unit
DDCU	DC-to-DC Converter Unit
DDCU-E	Digital Current-to-Direct Current/Converter Unit External

DDCU-I	Internal DDCU
DDCU-HP	Digital Current-to-Direct Current/Converter Unit-Heat Pipe
DIO	Discreet Input/Output
DMCS	Docking Mechanism Control System
DMCU	Docking Mechanism Control Unit
DMS-R	Data Management System-Russian
DOF	Degrees Of Freedom
DPA	Digital Preassembly
DPS	Data Processing System
DSAT	Desaturation
DSO	Detailed Supplementary Objectives
DTO	Development Test Objective
E/L	Equipment Lock
EA	Electrical Assembly
EACP	Extravehicular Audio Control Panel
EAIU	EMU Audio Interface Unit
EATCS	External Active Thermal Control System
ECLSS	Environmental Control and Life Support System
ECS	Environmental Control System
ECU	Electronics Control Unit
ED	Extended-height Deployable
EDDA	External Maneuvering Unit Don/Doff Assembly
EEATCS	Early External Active Thermal Control System
EELS	Emergency Egress Lighting System
EETCS	Early External Thermal Control System
EFGF	Electrical Flight-releasable Grapple Fixture
EIA	Electrical Interface Assembly
ELH	Electrical Harness
ELM-ES	Experiment Logistics Module-Exposed Section
ELPS	Emergency Lighting Power Supply
ELS	Emergency Lighting Strip
EMCS	European Modular Cultivation System
EMU	Extravehicular Mobility Unit
	EXPRESS memory Unit
EOM-1	End of Mission Minus 1
EPCE	Electrical Power Consuming Equipment
EPS	Electrical Power System
ER	Express Rack
ESA	European Space Agency
	External Sampling Adapter
ESP	External Stowage Platform
ESPAD	ESp-2 Attachment Device
ESSMDM	Enhanced Space Station Multiplexer/Demultiplexer



ESU	End Stop Unit
ETI	Elapsed Time Indicator
ETR	Express Transportation Rack
ETSD	Extravehicular Tool Storage Device
EU	Electronics Unit
EV	Extravehicular
EVA	Extravehicular Activity
EV-CPDS	Extravehicular-Charged Particle Directional Spectrometer
EVR	Extravehicular Robotics
EVSU	External Video Switching Unit
EXPRESS	EXpedite the PROcess of Experiments to the Space Station
EXT	Experimental Terminal
	External
FAWG	Flight Assignments Working Group
FC	Firmware Controller
FCB	Functional Cargo Block
FCC	Flat Controller Circuit
FCT	Flight Control Team
FCV	Flow Control Valve
FD	Flight Day
FDA	Fault Detection and Annunciation
FDI	Failure Detection and isolation
FDIR	Failure, Detection, Isolation and Recovery
FDS	Fire Detection and Suppression
FEPS	Front-End Processor System
FET	Field Effect Transistor
FGB	Fixed Grapple Bar
	Functional Cargo Block
FHRC	Flex Hose Rotary Coupler
FOR	Flight Operations Review
FPMU	Floating Potential Measurement Unit
FPP	Floating Point Potential
FPU	Fluid Pumping Unit
FQDC	Fluid Quick Disconnect Coupling
FR	Flight Rule
FRAM	Flight Releasable Attachment Mechanism
FRD	Flight Requirements Document
FRGF	Flight Releasable Grapple Fixture
FSE	Flight Support Equipment
FWCI	Firmware Configuration Item
FWD	Forward
GAS	Get Away Special

GFE	Government-Furnished Equipment
GFI	Ground Fault Interrupter
GJOP	Generic Joint Operations Panel
GLA	General Lighting Assembly General Luminare Assembly
GLONASS	Global Navigation Satellite System
GMT	Greenwich Mean Time
GNC	Guidance and Navigation Computer Guidance, Navigation, and Control
GPC	General Purpose Computer
GPS	Global Positioning System
GSE	Ground Support Equipment
GUI	Graphical User Interface
HAB	Habitat Module
HC	Hand Controller
HCA	Hollow Cathode Assembly
HCI	Human Computer Interface
HCOR	High-Rate Communications Outage Recorder
HCU	Heater Control Unit
HDPCG	High Density Protein Crystal Growth
HDR	High Data Rate
HEPA	High Efficiency Particulate Unit
HGA	High Gain Antenna Hollow Cathode Assembly
HHL	Handheld Lidar
HLA	High Level Analog
HPGT	High Pressure Gas Tank
HRF	Human Research Facility
HRFM	High Rate Frame Multiplexer
HRM	High Rate Modem
HX	Heat Exchanger
I/F	Interface
I/O	Input/Output
IAC	Internal Audio Controller
IAS	Internal Audio System
IATCS	Internal Active Thermal Control System
IBA	Integrated Boom Assembly
ICC	Integrated Cargo Carrier
ID	Identification
IDA	Integrated Diode Assembly
IDRD	Increment Definition Requirements Document
IDS	Integrated Documentation System

IEA	Integrated Equipment Assembly
IELK	Individual Equipment Liner Kit
IFHX	Interface Heat Exchanger
IFM	In-flight Maintenance
IGA	Inner Gimbal Assembly
IMCA	Integrated Motor Control Assembly
IMCS	Integrated Mission Control System
IMS	Inventory Management System
IMU	Impedance Matching Unit
IMV	Intermodule Ventilation
INCO	Instrumentation Communications Officer
INT	Internal
IOC	Input/Output Controller
IOCU	Input/Output Controller Unit
IP	International Partner
IRU	In-Flight Refill Unit
ISA	Internal Sampling Adapter
ISIS	International Subrack Interface Standard
ISO	Inventory and Stowage Officer
ISOV	Intermodule Ventilation Shut-Off Valve
ISPR	International Standard Payload Rack
ISS	International Space Station
ISSSH	International Space Station Systems Handbook
ISSIS	International Space Station Interface Standard
ISSPO	International Space Station Program Office
ITCS	Internal Thermal Control System
ITS	Integrated Truss Segment
ITVC	Intensified Television Camera
IUA	Interface Umbilical Assembly
IVA	Intravehicular Activity
IVSU	Internal Video Switch Unit
JEU	Joint Electronic Unit
JEUS	Joint Expedited Undocking and Separation
JSC	Johnson Space Center
K-BAR	Knee-Brace Assembly Replacement
km	kilometer
KSC	Kennedy Space Center
KYA	Keel Yoke Assembly
LA	Launch Aft
Lab	Laboratory Module
LAN	Local Area Network

LaRC	Langley Research Center
LAT	Latch
LB	Local Bus
LB-RWS	RWS Local Bus
LCA	Lab Cradle Assembly
	Loop Crossover Assembly
LCC	Laser Camera Controller
LCD	Liquid Crystal Display
LCH	Laser Camera Head
LCP	Lower Connector Panel
LCS	Laser Camera System
LDI	Local Data Interface
LDR	Low Data Rate
LDRI	Laser Dynamic Range Imager
LDU	Linear Drive Unit
LED	Light Emitting Diode
LEE	Latching End Effector
LEU	LEE Electronic Unit
L FDP	Load Fault Detection Protection
LGA	Low Gain Antenna
LIS	Laser Interface Software
LLA	Low Level Analog
LMC	Lightweight Multipurpose Carrier
LRU	Line Replaceable Unit
LT	Low Temperature
LTA	Launch To Activation
LTL	Low Temperature Loop
LTU	Load Transfer Unit
LVLH	Local Vertical Local Horizontal
MA	Mechanical Assembly
MAM	Manual Augmented Role
MBE	Metal Bellows Expander
MBS	Manual Berthing System
MBSU	Main Bus Switching Unit
MC	Midcourse Correction
MCA	Major Constituent Analyzer
MCAS	MBS Common Attach System
MCC	Mission Control Center
MCC-H	Mission Control Center-Houston
MCC-M	Mission Control Center-Moscow
MCDS	Multifunction CRT Display System
MCOR	Medium-Rate Communications Recorder
MCS	Motion Control System

MCU	MCU Control Software
MDA	MBS Computer Unit
MDL	Motor Drive Assembly
	Middeck Locker
	Mission Data Lead
MDM	Multiplexer/Demultiplexer
MDPS	Meteoroid and Debris Protection System
MEEP	Mir Environmental Effects Payload
MELFI	Minus Eighty-degree Laboratory Freezer for ISS
MER	Mission Evaluation Room
MET	Mission Elapsed Time
METOX	Metal Oxide
MFCV	Manual Flow Control Valve
MHS	MCU Host Software
MILA	Mode Indicating Light Assembly
MIM	Multi-Increment Manifest
MIP	Mission Integration Plan
MISSE	Materials ISS Experiment
MLI	Multi-Layer Insulation
mm	millimeter
MM/OD	Micrometeoroid/Orbital Debris
MOD	Mission Operations Directorate
MPES	Multipurpose Experiment Structure
MPEV	Manual Pressure Equalization Valve
MPLM	Multipurpose Logistics Module
MPM	Manipulator Positioning Mechanism
MRL	Manipulator Retention Latch
MSD	Mass Storage Device
MSFC	Marshall Space Flight Center
MSG	Microgravity Science Glovebox
MSS	Mobile Servicing System
MT	Mobile Transporter
	Moderate Temperature
MTCL	MT Capture Latch
MTL	Moderate Temperature Loop
MTS	Module-to-Truss Segment
MTSAS	Module-to-Truss Segment Attachment System
MTWsN	Move to Worksite Number
N/A	Not Applicable
N/R	Not Required
NASA	National Aeronautics and Space Administration
NC	Nominal Corrective
NCC	Nominal Corrective Combination

NCG	Non Condensable Gas
NCS	Node Control Software
NET	No Earlier Than
NIA	Nitrogen Interface Assembly
NIV	Nitrogen Introduction Valve
NLP	Narrow-sweep Langmuir Probe
NPRA	Negative Pressure Relief Assembly
NPRV	Negative Pressure Relief Valve
NTA	Nitrogen Tank Assembly
NTSC	National Television Standards Committee
O.D.	Outer Diameter
OBSS	Orbiter Boom Sensor System
OCA	Orbital Communications Adapter
OCAD	Operational Control Agreement Document
OCJM	Operator Commander Joint Position Mode
OCPM	Operator-Commanded POR Mode
OCS	Operations and Control Software
ODA	Orbiter Disconnect Assembly
ODM	Orbiter Arm Drive Mechanism
ODS	Orbiter Docking System
OIU	Orbiter Interface Unit
OIV	Oxygen Isolation Valve
OMI	On-Orbit Maintainable Item
OMS	Orbital Maneuvering System
OPP	OSVS Patch Panel
Ops	Operations
OPS LAN	Operations Local Area Network
ORBT	Optimized RBar Targeting Technique
ORCA	Oxygen Recharge Compressor Assembly
ORU	Orbital Replacement Unit
OTD	ORU Transfer Device
OSE	Orbiter Support Equipment
OSO	Operations Support Officer
OSVS	Orbiter Space Vision System
OSVU	Orbiter Space Vision Unit
OV	Orbiter Vehicle
P&S	Pointing and Support
P/L	Payload
PAD	PFR Attachment Device
PAS	Payload Attach System
PBA	Portable Breathing Apparatus
PC	Personal Computer

PCA	Pressure Control Assembly
PCAM	Protein Crystallization Apparatus for Microgravity
PCBM	Passive Cargo Berthing Mechanism
PCC	Power Converter Controller
PCG-STES	Protein Crystal Growth-Single Thermal Enclosure System
PCM	Phase Change Material
PCMCIA	Personal Computer Memory Card International Adapter
PCMMU	Pulse Code Master Modulation Unit
P-code	Precision code
PCP	Pressure Control Panel
PCVP	Pump and Control Valve Package
PCR	Portable Computer Receptacle
PCS	Portable Computer System
PCT	Post-Contact Thrusting
PCU	Plasma Connector Unit
PCVP	Pump and Control Valve Package
PD	Physical Device
PDA	Payload Disconnect Assembly
PDB	Power Distribution Box
PDGF	Power and Data Grapple Fixture
PDI	Payload Data Interface
PDIP	Payload Data Interface Panel
PDRS	Payload Deployment and Retrieval System
PDU	Power Drive Unit
PEC	Passive Experiment Container
	Payload Experiment Carrier
PEHB	Payload Ethernet Hub Bridge
PEHG	Payload Ethernet Hub Gateway
PEV	Pressure Equalization Valve
PFCS	Pump Flow Control Subassembly
PFE	Portable Fire Extinguisher
PFM	Pulse Frequency Modulation
PFME	Pore Formation and Mobility Experiment
PFR	Portable Foot Restraint
PG	Product Group
PGBA	Plant Generic Bioprocessing Apparatus
PGSC	Portable General Support Computer
PGT	Pistol Grip Tool
PHALCON	Power, Heating, Articulation, Lighting, and Control Officer
PIP	Plasma Impedance Probe
PJAM	Pre-stored Joint Position Autosequence Mode
PLB	Payload Bay
PLBD	Payload Bay Doors

PM	Pump Module
PMA	Pressurized Mating Adapter
PMCU	Power Management Control Unit
PMP	Payload Mounting Panel
PNOM	Procedural Nomenclature
POA	Payload/ORU Accommodation
POC	Point of Contact
POEMS	Passive Observatories for Experimental Microbial Systems
POR	Point of Reference
POST	Power On Self-Test
PPA	Pump Package Assembly
PPAM	Pre-stored POR Autosequence Mode
PPL	Pre-Positioned Load
PPRA	Positive Pressure Relief Assembly
PPRV	Positive Pressure Relief Valve
PRD	Payload Retention Device
PRI	Primary
PRLA	Payload Retention Latch Assembly
Prox-Ops	Proximity Operations
PSP	Payload Signal Processor
PTCS	Passive Thermal Control System Positive Thermal Control System
PTU	Pan/Tilt Unit
PUI	Program Unique Identifier
PV	Photovoltaic
PVCA	Photovoltaic Controller Application
PVCE	Photovoltaic Controller Element
PVCU	Photovoltaic Controller Unit
PVM	Photovoltaic Module
PVR	Photovoltaic Radiator
PVTCS	Photovoltaic Thermal Control System
PWM	Pulse Width Modulator
PWP	Portable Work Platform
PWR	Portable Water Reservoir
PYR	Pitch Yaw Roll
QD	Quick Disconnect
R/F	Refrigerator/Freezer
R/P	Receiver/Processor
R&MA	Restraint and Mobility Aid
RAB	Rack Attachment Block
RACU	Russian-to-American Converter Unit
RAIU	Russian Audio Interface Unit



RAM	Random Access Memory
RAMV	Rheostat Air Mix Valve
RBB	Right Blanket Box
RBI	Remote Bus Isolator
RBVM	Radiator Beam Valve
RCA	Remote Control Amplifier
RCC	Reinforced Carbon-Carbon
RCS	Reaction Control System
RF	Radio Frequency
RFCA	Rack Flow Control Assembly
RFG	Radio Frequency Group
RGA	Rate Gyro Assemblies
RHC	Rotational Hand Controller
RHX	Regenerative Heat Exchanger
RIC	Rack Interface Controller
RJMC	Rotary Joint Motor Controller
RMS	Remote Manipulator System
ROBO	Robotics
ROEU	Remotely Operated Electrical Umbilical
ROFU	Remote Operated Fluid Umbilical
ROOBA	Recharge Oxygen Orifice Bypass Assembly
RPC	Remote Power Controller
RPCM	Remote Power Control Mechanism Remote Power Controller Module
RPDA	Remote Power Distribution Assembly
RPM	Rbar Pitch-over Maneuver
RPOP	Rendezvous and Prox-Ops Program
RS	Russian Segment
RSP	Resupply Stowage Platform
RSR	Resupply Stowage Rack
RSTS	Rack Standalone Temperature Sensor
RSU	Roller Suspension Unit
RT	Remote Terminal
RTL	Ready to Latch
RTD	Resistive Thermal Device
RWS	Robotic Workstation
S/W	Software
SA	Solar Array
SAPA	Small Adapter Plate Assembly
SARJ	Solar Alpha Rotary Joint
SASA	S-band Antenna Support Assembly
SAW	Solar Array Wing
SCA	Switchgear Controller Assembly

SCI	Signal Conditioning Interface
SCMI	Serial Command and Monitoring Interface
SCU	Service and Cooling Umbilical
	Sync and Control Unit
SD	Smoke Detector
SDO	Solenoid Driver Output
SDS	Sample Delivery System
SELS	SFOC Electronic Library System
SEM	Shunt Electronics Module
SFA	Small Fine Arm
SFCA	System Flow Control Assembly
SGANT	Space-to-Ground Antenna
SIGI	Space Integrated Global Positioning System/Inertial Navigation System
SJRM	Single Joint Rate Mode
SLDP	SpaceLab Double Pallet
SLP	SpaceLab Pallet
SM	Service Module
SMCC	Shuttle Mission Control Center
SOC	State of Charge
SOV	Shutoff Valve
SPCE	Servicing Performance and Checkout Equipment
SPD	Serial Parallel Digital
	Spool Positioning Device
SPDA	Secondary Power Distribution Assembly
SPDM	Special Purpose Dexterous Manipulator
SPG	Single-Point Ground
SPM	Solar Power Module
SRAM	Static Random Access Memory
SRMS	Shuttle Remote Manipulator System
SSAS	Segment-to-Segment Attach System
SSBA	Space Station Buffer Amplifier
SSC	Station Support Computer
	Subsystem Computer
SSMDM	Space Station Multiplexer/Demultiplexer
SSOR	Space-to-Space Orbiter Ratio
SSOV	Sample Line Shutoff Valve
SSP	Space Shuttle Program
	Standard Switch Panel
SSPCM	Solid State Power Control Module
SSRMS	Space Station Remote Manipulator System
SSSR	Space-to-Space Station Radio
SSU	Sequential Shunt Unit
STCR	Starboard Thermal Control Radiator

STES	Single Thermal Enclosure System
STS	Space Transportation System
SVS	Space Vision System
SX	Short Extension
TA	Thruster Assist Trunnion Angle
TBD	To Be Determined
TC	Terminal Computer
TCCS	Trace Contaminant Control Subassembly
TCCV	Temperature Control and Check Valve
TCS	Thermal Control System Trajectory Control System
TD	Translation Drive
TDRS	Tracking and Data Relay Satellite
TDRSS	Tracking and Data Relay Satellite System
TEA	Torque Equilibrium Attitude
TFL	Telemetry Format Load
TFR	Translation Foot Restraint
THA	Thermal Housing Assembly
THC	Temperature and Humidity Control Translational Hand Controller
THOR	Thermal Operations and Resources Officer
TI	Terminal Phase Initiation
TIG	Time of Ignition
TM	Torque Motor
TORF	Twice Orbital Rate Flyaround
TORU	Teleoperator Control Mode
TORVA	Twice Orbital Rate +Rbar to +Vbar Approach
TP	Total Pressure
TPL	Transfer Priority List
TPS	Thermal Protection System
TRC	Transmitter Receiver Controller
TRRJ	Thermal Radiator Rotary Joint
TSA	Toolbox Stowage Assembly
TTCR	Trailing Thermal Control Radiator
TUS	Trailing Umbilical System
TUS-RA	Trailing Umbilical System-Reel Assembly
TVCIC	Television Camera Interface Control Television Camera Interface Converter
TVIS	Treadmill Vibration Isolation System
TWMV	Three-Way Mixing Valve
UB	User Bus

UCP	Unpressurized Cargo Pallet
UDG	User Data Generation
UHF	Ultrahigh Frequency
UIA	Umbilical Interface Assembly
UIL	User/Utility Interface Language
UIP	Utility Interface Panel
ULCAS	Unpressurized Logistics Carrier Attach System
ULC-ND	Unpressurized Logistics Carrier—Non-Deployable
ULF-1.1	Utilization Logistics Flight 1.1
UMA	Umbilical Mechanism Assembly
UOP	Utility Outlet Panel
USA	United Space Alliance
USL	U.S. Laboratory
USOS	United States On-Orbit Segment
UTA	Universal Trunnion Attachment
	Utility Transfer Assembly
UTAS	Universal Trunnion Attachment System
VAJ	Vacuum Access Jumper
VBSP	Video Baseband Signal Processor
VCSA	Video Camera Support Assembly
VDA-2	Vapor Diffusion Apparatus—Second Generation
VDS	Video Distribution System
VDU	Video Distribution Unit
VES	Vacuum Exhaust System
VGS	Video Graphics Software
VMDS	Valve Motor Drive Switch
VPMP	Vented Payload Mounting Panel
VRCV	Vent/Relief Control Valve
VRIV	Vent/Relief Isolation Valve
VRS	VES Resource System
VRV	Vent/Relief Valve
VSC	Video Signal Converter
VSSA	Video Support Stanchion Assembly
	Video System Support Assembly
WETA	WVS External Transceiver Assembly
WHS	Workstation Host Software
WIF	Worksite Interface
WLE	Wing Leading Edge
WLP	Wide Langmuir Probe
WMV	Water Modulating Valve
WORF	Window Observational Research Facility
WOV	Water ON/OFF Valve

---

WPP	Water Pump Package
WRM	Water Recovery Management
WS	Water Separator
WV	Work Volume
WVA	Water Vent Assembly
WVS	Wireless Video System
ZSR	Zero-g Stowage Rack



# MEDIA ASSISTANCE

## NASA TELEVISION TRANSMISSION

NASA Television is carried on an MPEG-2 digital signal accessed via satellite AMC-6, at 72 degrees west longitude, transponder 17C, 4040 MHz, vertical polarization. For those in Alaska or Hawaii, NASA Television will be seen on AMC-7, at 137 degrees west longitude, transponder 18C, at 4060 MHz, horizontal polarization. In both instances, a Digital Video Broadcast (DVB)-compliant Integrated Receiver Decoder (IRD) (with modulation of QPSK/DBV, data rate of 36.86 and FEC  $\frac{3}{4}$ ) will be needed for reception. The NASA Television schedule and links to streaming video are available at:

<http://www.nasa.gov/ntv>

NASA TV's digital conversion will require members of the broadcast media to upgrade with an 'addressable' Integrated Receiver Decoder, or IRD, to participate in live news events and interviews, press briefings and receive NASA's Video File news feeds on a dedicated Media Services channel. NASA mission coverage will air on a digital NASA Public Services ("Free to Air") channel, for which only a basic IRD will be needed.

The schedule for television transmissions from the orbiter and for mission briefings will be available during the mission at Kennedy Space Center, Fla.; Marshall Space Flight Center, Huntsville, Ala.; Dryden Flight Research Center, Edwards, Calif.; Johnson Space Center,

Houston; and NASA Headquarters, Washington. The television schedule will be updated to reflect changes dictated by mission operations.

## Status Reports

Status reports on countdown and mission progress, on-orbit activities and landing operations will be posted at:

<http://www.nasa.gov/shuttle>

This site also contains information on the crew and will be updated regularly with photos and video clips throughout the flight.

## Briefings

A mission press briefing schedule will be issued before launch. During the mission, status briefings by a flight director or mission operations representative and Mission Management Team members will occur every day. The updated NASA television schedule will indicate when mission briefings are planned.

## Internet Information

Information on other current NASA activities is available at:

<http://www.nasa.gov/home>

Resources for educators can be found at the following address:

<http://education.nasa.gov>





## PUBLIC AFFAIRS CONTACTS

### HEADQUARTERS WASHINGTON, DC

Allard Beutel  
Public Affairs Specialist  
Space Operations  
202-358-4769

Katherine Trinidad  
Public Affairs Specialist  
Space Operations  
202-358-3749

Joe Pally  
Public Affairs Specialist  
Space Operations  
202-358-7239

Melissa Mathews  
Public Affairs Specialist  
International Partners  
202-358-1272

### JOHNSON SPACE CENTER HOUSTON, TEXAS

James Hartsfield  
News Chief  
281-483-5111

Kyle Herring  
Public Affairs Specialist  
Space Shuttle Program Office  
281-483-5111

Kylie Clem  
Public Affairs Specialist  
International Space Station  
& Mission Operations  
281-483-5111

Lynnette Madison  
Public Affairs Specialist  
Engineering  
281-483-5111

Rob Navias  
Program and Mission Operations Lead  
281-483-5111

### KENNEDY SPACE CENTER FLORIDA

Bruce Buckingham  
News Chief  
321-861-2468

Jessica Rye  
Public Affairs Specialist  
Space Shuttle  
321-867-2468

Tracy Young  
Public Affairs Specialist  
International Space Station  
321-867-2468

### MARSHALL SPACE FLIGHT CENTER HUNTSVILLE, ALABAMA

Dom Amatore  
Public Affairs Manager  
256-544-0034

June Malone  
Public Affairs Specialist  
Space Shuttle Propulsion  
256-544-0034



## **STENNIS SPACE CENTER MISSISSIPPI**

Linda Theobald  
Public Affairs Specialist  
228-688-3249

Paul Foerman  
News Chief  
228-688-1880

Rebecca Strecker  
Public Affairs Specialist  
228-688-3346

## **AMES RESEARCH CENTER MOFFETT FIELD, CALIFORNIA**

Mike Mewhinney  
News Chief  
650-604-3937

Jonas Dino  
Public Affairs Specialist  
650-604-5612

## **DRYDEN FLIGHT RESEARCH CENTER CALIFORNIA**

Alan Brown  
News Chief  
661-276-2665

Leslie Williams  
Public Affairs Specialist  
661-276-3893

## **GLENN RESEARCH CENTER CLEVELAND, OHIO**

Lori Rachul  
News Chief  
216-433-8806

Katherine Martin  
Public Affairs Specialist  
216-433-2406

## **LANGLEY RESEARCH CENTER HAMPTON, VIRGINIA**

H. Keith Henry  
Deputy, Office of Public Affairs  
757-864-6120

## **UNITED SPACE ALLIANCE**

Mike Curie  
Space Flight Operations Contract  
281-483-9251  
321-861-3805

Kari Fluegel  
Houston Operations  
281-280-6959

Tracy Yates  
Florida Operations  
321-861-3956

## **BOEING**

Ed Memi  
Media Relations  
Boeing NASA Systems  
281-226-4029