

NASA TECHNICAL
MEMORANDUM

December 1974

NASA TM X-64855



MSFC SKYLAB EXTRAVEHICULAR ACTIVITY
DEVELOPMENT REPORT

Skylab Program Office

NASA

*George C. Marshall Space Flight Center
Marshall Space Flight Center, Alabama*

ACKNOWLEDGEMENT

Development of the Skylab EVA system was the result of dedicated work by a diverse team of personnel from both government and industry.

The author wishes to thank the staff of the MSFC Neutral Buoyancy Simulator; C.M. Lewis and D.L. Turpen of the Marshall Center; the many flight crew and support personnel at Johnson Space Center that participated in the development; and personnel of: Grumman Aerospace Corp., Teledyne Brown Engineering, URS-Matrix, Martin Marietta Aerospace, and McDonnell Douglas Astronautics-Eastern Division.

Special thanks are given to Harry B. Beazley of Martin Marietta Aerospace for his dedicated assistance in preparation of this report.

TABLE OF CONTENTS

	<u>Page</u>
ACKNOWLEDGEMENT	ii
TABLE OF CONTENTS	iii
LIST OF ILLUSTRATIONS AND TABLES	iv
NON-STANDARD ABBREVIATIONS.....	vii
SECTION I INTRODUCTION	1
SECTION II BACKGROUND	3
A. Workshop Evolution	3
B. ATM Evolution	
SECTION III EARLY CLUSTER CONCEPT - EVA EGRESS FROM AM	9
A. Cluster Configuration	9
B. EVA Requirements and Guidelines	10
C. Workstations and Canister Access	13
D. Transfer and Translation Concepts	36
SECTION IV FINAL WET WORKSHOP CONCEPT - EVA EGRESS FROM LM	49
A. Cluster Configuration	49
B. EVA Requirements and Guidelines	50
C. Workstations and Canister Access	52
D. Transfer and Translation Concepts	65
SECTION V DRY WORKSHOP CONCEPT - EVA EGRESS FROM AM	81
A. Cluster Configuration	81
B. EVA Requirements and Guidelines	82
C. Workstations and Canister Access	84
D. Transfer and Translation Concepts	91
SECTION VI CONCLUSIONS AND RECOMMENDATIONS	123

LIST OF ILLUSTRATIONS AND TABLES

<u>Figure</u>		<u>Page</u>
1	S-IV Stage - Gemini Space Laboratory Concept.....	3
2	S-IVB Spent Stage Laboratory	4
3	Airlock Module Launch Configuration	5
4	Early Clustered Workshop Concept	6
5	Early Simplified ATM Concept Using Apollo CSM	7
6	Early Cluster Solar Array Configuration.....	9
7	ATM Cruciform Solar Array and S-IVB Stage Solar Array..	10
8	Early LM/ATM Configuration and Experiment Package Arrangement	11
9	Gemini-Type Foot Restraints (Dutch Shoes)	14
10	LM/ATM Configuration (June 1967)	15
11	LM-End Workstation Configuration	16
12	Canister Rotation Requirement for H-Alpha 1 Film Magazine Retrieval	17
13	LM-End Workstation Simulation Showing Structural Interference	18
14	LM-End Workstation Evolution	19
15	LM-End Workstation Ingress	20
16	LM-End Film Magazine Retrieval	21
17	LM-End Workstation With Two Diagonal Struts	23
18	Single Rail Sun-End Workstation Mounted on ATM Solar Shield	26
19	Ladder-Type, Telescoping Workstation (Concept IV)	28
20	Combined Translation Rail and Ladder-Type Workstation (Concept IV)	29
21	Variations of Sun-End Workstation Concept IV	30
22	Single Translation Rail, Sliding Workstation Concept ..	31
23	Single Rail Sun End Film Retrieval Simulation	32
24	Dual Rail Workstation Platform Test Configuration	33
25	Modified Dual Rail Workstation Test Configuration	34
26	Sun End Film Retrieval With Canister Rotated 80° Clockwise	34
27	Dual-Rail Platform With Canister Rotated 95° Counterclockwise	35
28	Solar Shield Opening for Combined Translation Rail and Sun-End Workstation Concept	36
29	Concept for Sun-End Workstation On Rotating Solar Shield Section	37
30	ATM Film Retrieval EVA Routes	38
31	Serpentuator Concept	39
32	Serpentuator Concept Evaluation Model	40
33	Serpentuator Umbilical Management and Cargo Carrier Concept	41
34	Roll-Up Extendible-Boom Deployment Concept	41
35	Ei-Storable, Tubular Extendible Member (STEM) Device ..	42
36	Application Technology Satellite (ATS) Boom Deployer ..	43
37	Astro Mast Lattice Boom Deployment Concept	43
38	Single Rail Manual Translation Concept	44
39	Continuous Rail Translation System	45

LIST OF ILLUSTRATIONS AND TABLES (CONT'D)

<u>Figure</u>		<u>Page</u>
40	Cluster EVA Translation Handrail Locations.....	46
41	Final Wet Workshop Orbital Configuration.....	50
42	Proposed Workstation Relocation Concept.....	52
43	LM Hatch Workstation Concepts.....	54
44	Canister Roll Control Panel and Gimbal Lock System...	44
45	Final Wet Workshop LM-End Workstation Configuration..	57
46	Sun-End Workstation Mounted on Rotating Solar Shield Section.....	57
47	Sun-End Workstation Ingress Problems	58
48	Workstation Foot Restraint and Stability Problems....	59
49	Sun-End Workstation Location Design Requirements	60
50	Deployable Sun-End Workstation Concept	61
51	Trolley Translator Device.....	62
52	Trolley Sun-End Workstation Concept	63
53	Deployable Sun-End Workstation With Canister Mounted Hand Holds	64
54	Permanently Mounted Sun-End Workstation	65
55	Final Wet Workshop Sun-End Workstation Configuration.	66
56	Single Rail Translation From LM Hatch	67
57	Proposed Workstation Relocation and Translation Rail Concept	68
58	Proposed Crew and Cargo Carrier Concept	69
59	Parallel Translation Rails and Film Magazine Dolly Concept	69
60	Translator or Trolley System	70
61	LM Interim Stowage Device in LM-A Forward Cabin Loading Position	71
62	LM Interim Stowage Tree Attached to Trolley Translator	72
63	LM-End Film Transfer Flip-Over Device	73
64	Neutral Bucyancy Stability Evaluation of the Trough Foot Restraint Concept	74
65	Parallel Translation Rail Simulation Test	75
66	Parallel Rail Translation Concept and Film Transfer Devices	76
67	EVA Film Retrieval Procedure	78
68	LM/ATM EVA Translation and Film Transfer System	80
69	Skylab EVA Life Support System	82
70	Skylab Cluster Configuration	83
71	ATM Workstation and AM Hatch Orientation	85
72	Skylab ATM Film Retrieval EVA Route	85
73	Proposed Methods of Expanding Airlock Working Volume.	86
74	Universal Foot Restraint	88
75	Canister Rotation Control Panel	89
76	Center Workstation Configuration	90
77	Sun-End Workstation Configuration	90
78	AM Film Magazine Stowage Concepts	91
79	Dry Workshop Film Transfer and Translation Concepts..	93
80	AM External or FAS Workstation Concept	94
81	Prototype Extendible Boom and Clothesline Evaluation.	95
82	Sun-End Film Transfer Concepts.....	96

LIST OF ILLUSTRATIONS AND TABLES (CONCL.)

<u>Figure</u>		<u>Page</u>
83	Proposed Sun End Changes for The Extendible Boom Film Transfer Concept	97
84	FAS Workstation Arrangement for Film Transfer Devices	98
85	Center Workstation Mobility Aids and Film Transfer Provisions	99
86	Transfer and Sun-End Workstation Arrangement	100
87	Film Transfer Boom and Hook	100
88	Film Transfer Boom and Film Tree Receptacle Location Evaluation During Neutral Buoyancy Test	101
89	ATM Sun End Film Retrieval Components	102
90	EVA Lighting Evaluation	103
91	Film Transfer Boom Hook	104
92	Solar Illumination Study	105
93	Center Workstation Film Tree	106
94	Typical Center Workstation Access Doors With Film Magazine Installed	106
95	Sun-End Access Door With Film Magazine Installed ...	107
96	S082 Film Magazine in Sun-End Temporary Stowage Container	107
97-102	Film Retrieval Operations Using Film Transfer Boom .	108
103	Clothesline Assembly and Stowage Container	114
104-107	Film Transfer Operations Using Clothesline Assembly.	115
108-111	Contingency Solar Panel Deployment	119

Table

1	Dry Workshop Film Transfer and Translation Concepts Concepts	92
---	-----------------------------------------------------------------------	----

NON STANDARD ABBREVIATIONS

AAP	Apollo Applications Program
ALSA	Astronaut Life Support Assembly
AM	Airlock Module
AS&E	American Science and Engineering
ATM	Apollo Telescope Mount
ATS	Application Technology Satellite
CM	Command Module
CSM	Command and Service Module
EOP	Emergency Oxygen Pack
EVA	Extravehicular Activity
FAS	Fixed Airlock Shroud
GSFC	Goddard Space Flight Center
H-ALPHA	Hydrogen Alpha
HAO	High Altitude Observatory
HCO-B	Harvard College Observatory "B" Experiment (See S055B)
HCO-C	Harvard College Observatory "C" Experiment (See S083)
IVA	Intravehicular Activity
LEM	Lunar Excursion Module
LM	Lunar Module
LM-A	Lunar Module Ascent Stage
LM/ATM	Lunar Module/Apollo Telescope Mount Concept
LM&SS	Lunar Mapping and Survey Station Module
LSU	Life Support Umbilical
MDA	Multiple Docking Adapter
MSFC	Marshall Space Flight Center
NRL-A	Naval Research Laboratory "A" Experiment (See S082A)
NRL-B	Naval Research Laboratory "B" Experiment (See S082B)
OPS	Oxygen Purge System
OSSA	Office of Space Sciences and Applications
PCU	Pressure Control Unit
PECS	Portable Environmental Control System
PLSS	Portable Life Support System
RM	Resupply Module
SLA	Spacecraft LM Adapter
SOP	Secondary Oxygen Pack
SSE	Spent Stage Experiment
SSESM	Spent Stage Experiment Support Module
STEM	Bi-Storable, Tubular Extendible Member
S052	White Light Coronagraph Experiment (HAO)
S054	X ray Spectrographic Telescope Experiment (AS&E)
S055B	Ultraviolet Spectroheliometer
S056	X ray Telescope Experiment (MSFC)
S082A	Extreme Ultraviolet Spectroheliograph Experiment (NRL)

NON STANDARD ABBREVIATIONS
(Cont'd)

S082B Spectrograph and Extreme Ultraviolet Monitor
Experiment (NRL)

S083 Extreme Ultraviolet Scanning Spectrometer
Experiment

SECTION I INTRODUCTION

Skylab Extravehicular Activity (EVA) system development was begun under the Apollo Applications Program (AAP). The requirement for EVA was established during the mission definition phase of the Apollo Telescope Mount (ATM), Skylab's solar physics observatory. The ATM officially became a part of the AAP design in December 1966.

Initially, EVA was required to allow the crew to service the solar physics experiments by retrieving and replacing the film at intervals throughout the mission. Later, other experiments were added which required EVA. During the Skylab mission, EVA was used for several off-nominal tasks added after launch including the Skylab salvage operation and the observations of Comet Kohoutek.

The EVA systems design changed in consonance with the changes in configuration of the orbital cluster. Three different EVA system designs were made, each reflecting the then current design concept for the cluster. Each time all design approaches to the tasks of equipment transfer and workstation location were reconsidered. Although many EVA system designs changed each time, others withstood the re-examinations and remained essentially unchanged. Thus, the iterations served to strengthen the final design.

This report traces the Marshall Space Flight Center (MSFC) role in the development of Skylab EVA systems from the earliest concepts to the final as-flown configuration. The lessons learned through design, development, and testing of the many approaches which resulted in the flexible, simple EVA system used on Skylab, are indicated.

SECTION II. BACKGROUND

Conceptual orbital laboratory studies related to using an S-IVB spent stage and independent Apollo Telescope Mount (ATM) studies were conducted concurrently under the early Apollo Extension Systems and Apollo Applications Programs (AAP). Each study was relevant to Skylab EVA systems development. By the end of 1966, these studies were combined into a clustered orbiting laboratory concept; the forerunner of Skylab.

A. S-IVB Workshop Evolution

Early in the Saturn Program the Douglas Aircraft Company proposed the use of a spent S-IV stage as a manned space laboratory. The space laboratory and a Gemini capsule with two crewmen were to be boosted by an S-I launch vehicle and inserted into orbit by the S-IV stage. After S-IV hydrogen depletion, the tank would be purged, then filled with stored atmosphere and conditioned for crew entry. Figure 1 shows this early concept.

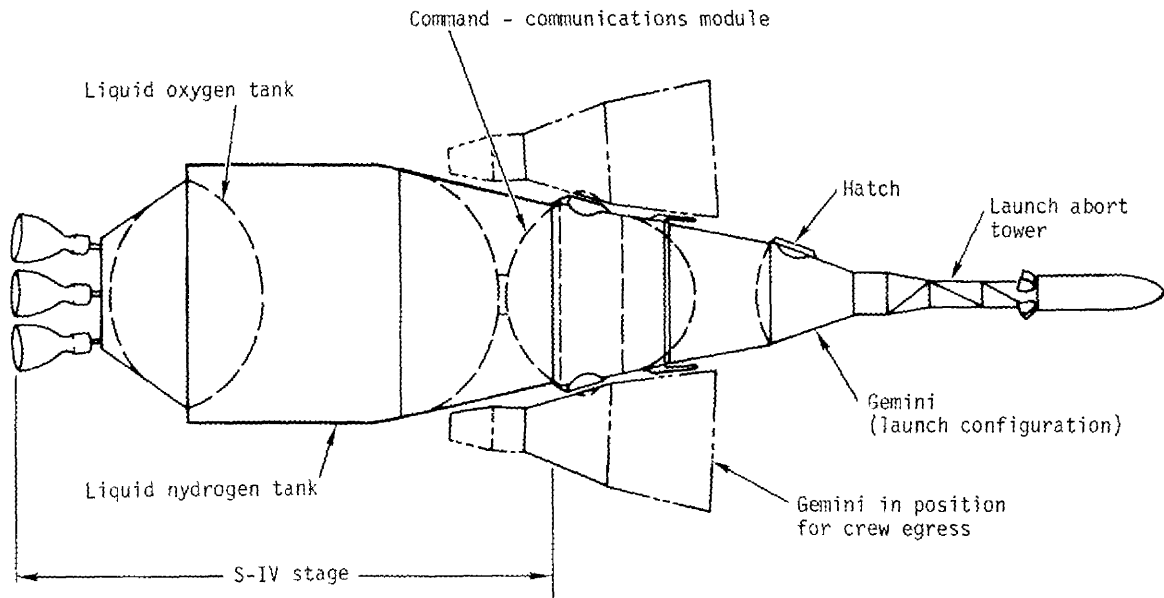

Figure 1. S-IV Stage - Gemini Space Laboratory Concept

A number of different concepts for a space laboratory workshop were subsequently envisioned by study groups; some involving new hardware. However, the Apollo Extensions Support study established that system equipment and module components developed for Gemini and Apollo, with logical modifications, were more than adequate to support the development of an orbiting workshop.

In August 1965, NASA replaced the Apollo Extension Systems Program with the Apollo Applications Program. The latter program involved

design studies of an "in-orbit" conversion of a spent S-IVB stage to a manned shelter and workshop. The ability of man to perform certain functions in space, including EVA and manned spacecraft docking activities, had already been demonstrated during Project Gemini. Further development of this ability required more space than was available in either the Gemini or Apollo spacecraft. This space could be provided by using the S-IVB spent stage.

As a result of these studies on the S-IVB Spent Stage Experiment, NASA determined to develop an orbiting research laboratory without interfering with the Apollo Lunar Landing mission. An appraisal of Gemini hardware applicability for the project resulted in the development of a Spent Stage Experiment Support Module (SSESM) to provide an interconnecting tunnel and airlock between the Apollo command and service module (CSM) and the S-IVB stage. The SSESM was to be launched on a Saturn IB along with a CSM. In orbit, the CSM would separate from the vehicle and dock to the SSESM in the same manner as with a Lunar Excursion Module (LEM) for lunar landing missions (Figure 2). The crew would then proceed to vent and purge the S-IVB hydrogen tank and perform an EVA to remove 72 bolts securing the S-IVB forward dome manhole cover, connect a flexible tunnel extension to complete the pressurized passageway, and connect cryogenic hydrogen and oxygen and electrical telescoping boom umbilicals to the CSM.

The experiments to be performed were mostly biomedical and would be accomplished in the command module (CM). No crew quarters would be set up in the S-IVB, and the basic crew activity would involve familiarization with zero-g locomotion in a controlled and enclosed environment. Additional EVA's would be performed to gain access to the exterior experiment area and to externally stowed equipment. A modified Gemini hatch and sill would be mounted in the SSESM airlock with the

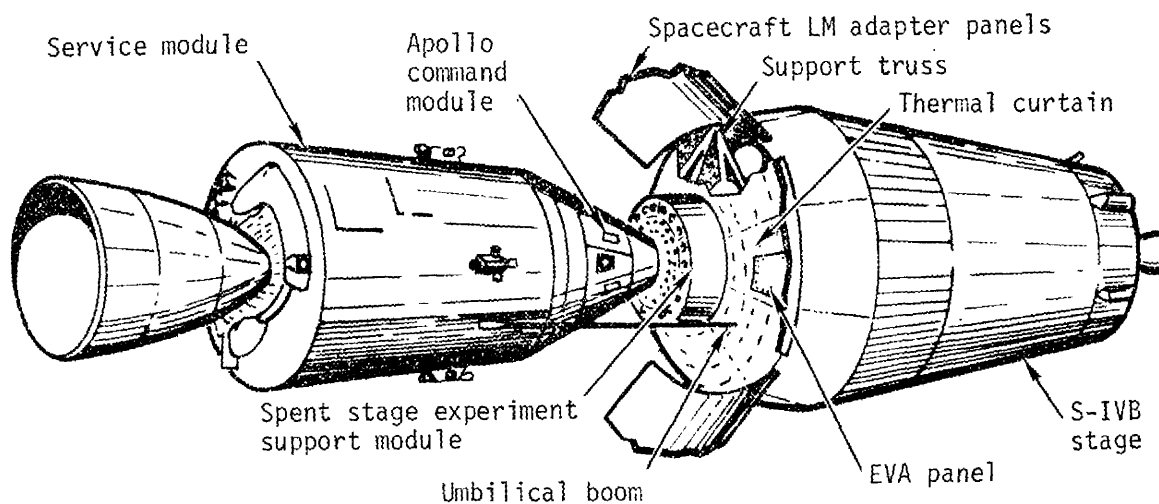

Figure 2. S-IVB Spent Stage Laboratory

hatch window oriented to provide visual contact between the EVA crewman and a crewman positioned in the forward pressurized section of the tunnel. Handholds and restraint fittings would be located at workstations and around the vehicle exterior to aid in EVA operations. A thermal protective curtain enclosing the cavity within the Spacecraft LEM Adapter (SLA) would contain a removable panel for EVA egress.

As the program matured, mission definition and systems requirements underwent considerable evolution. Habitability and experiment provisions were gradually incorporated in design of the S-IVB stage, and the SSES was redesignated the Airlock Module (AM). The Gemini Adapter was replaced by a short, cylindrical pressure vessel with an axial docking port and increased external radiator area to provide more pressurized volume for expendables and experiment launch stowage (Figure 3).

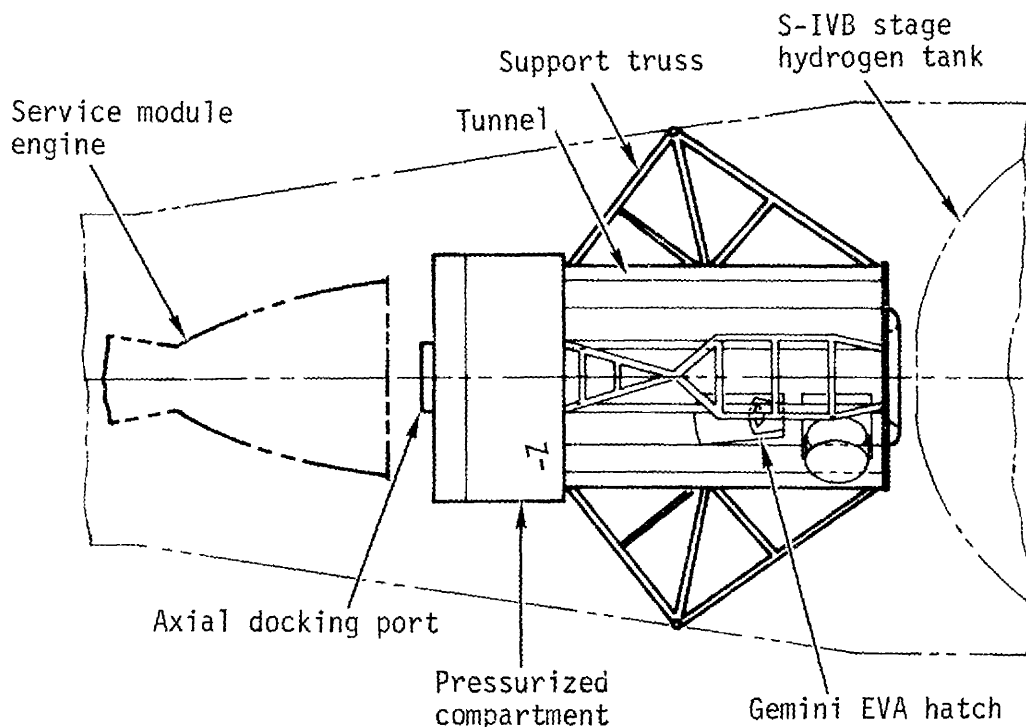

Figure 3. Airlock Module Launch Configuration

Because of problems experienced during EVA on Gemini, concepts were developed for easier removal of the S-IVB forward dome cover and a permanently installed flexible tunnel extension. This would reduce EVA time requirements.

Studies completed during September and October 1966 established the feasibility of combining certain AAP missions. The studies considered a combined configuration consisting of the S-IVB stage, an AM, a

CSM, and the Lunar Module Ascent stage (LM) with an Apollo Telescope Mount (ATM), with provisions for accommodating a Lunar Mapping and Survey Station Module (LM&SS) and a Resupply Module (RM).

In December 1966, a NASA directive defined the requirements and initiated action for design of a clustered configuration concept for the AAP missions. The combined mission would consist of four Saturn IB flights. The first would carry the crew aboard an Apollo CSM along with the LM&SS module. After completion of the LM&SS mission, the unmanned Earth-orbiting laboratory, renamed the "Orbital Workshop," would be launched when the Orbital Workshop achieved orbit, the CSM would rendezvous, attach the LM&SS module and dock. The crew would passivate the S-IVB stage and activate the Orbital Workshop for a 28 day mission. Several months later a second crew would be launched with a RM. After docking the RM to the Orbital Workshop the CSM would prepare to rendezvous with an LM/ATM, launched on the fourth vehicle. With the LM/ATM and CSM docked to the Orbital Workshop, the crew would perform solar astronomy and other experiments during a 56 day mission. The capability for three subsequent revisits to reactivate the workshop and ATM were planned. Figure 4 shows an early on-orbit cluster concept. The

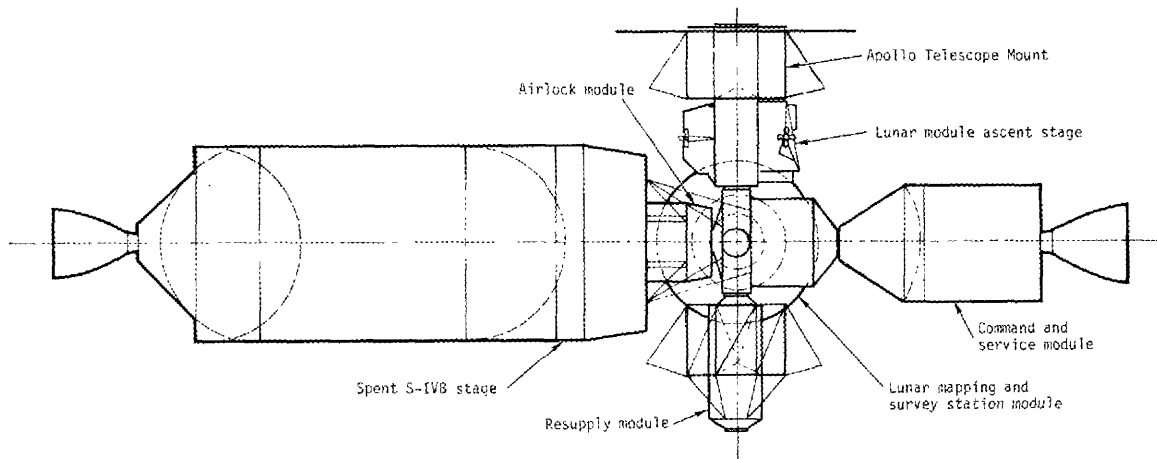

Figure 4. Early Clustered Workshop Concept

modules are docked to a lengthened cylindrical compartment with four radial docking ports in addition to the axial port. This compartment was named the Multiple Docking Adapter (MDA). The AM retained the Gemini hatch for EVA operations.

B. ATM Evolution

A series of feasibility studies to include optical technology experiments on extended Apollo flights culminated in January 1966 when the Office of Space Sciences and Applications (OSSA) sent a request for proposals to NASA centers. The resulting concept was a three-axis

oriented solar research platform mounted in one of the six sections of the Apollo Service Module (Figure 5). Trade off studies conducted in

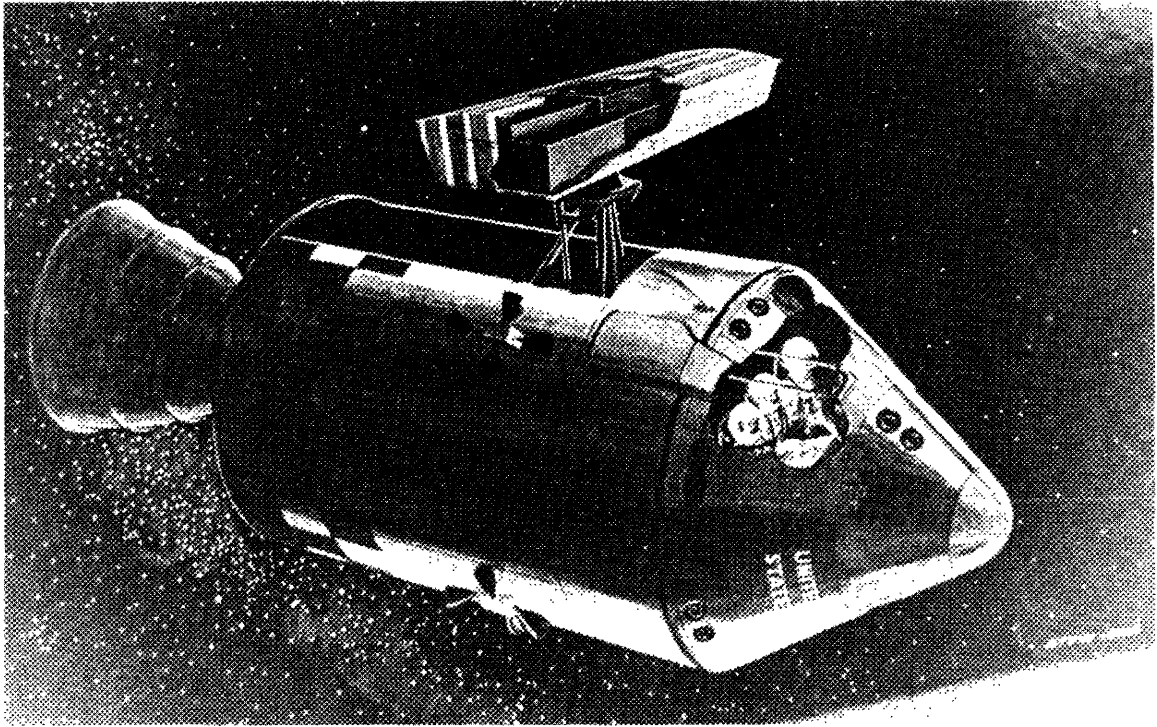

Figure 5. Early Simplified ATM Concept Using Apollo CSM

April 1966 indicated certain advantages for mounting the telescopes to a Lunar Module (LM) instead of the service module. On the basis of these findings MSFC received a request to study the LM configuration with a hard mounted ATM. After completion of the study, NASA assigned the ATM responsibility to MSFC.

A preliminary ATM project development plan, submitted in July 1966, defined the LM/ATM system. The primary design located an experiment package, containing up to four telescopes, in a universal rack which replaced the LM descent stage. Two Saturn IB vehicles were required for the LM/ATM mission. One would carry the unmanned LM/ATM while the other vehicle carried the three man crew aboard an Apollo CSM. After rendezvous and docking, two crewmen would transfer to the LM/ATM, undock from the CSM, and perform the experiments in a free-flying decoupled mode for seven days. At the end of this period they would re-dock, exchange one crewman and undock for another seven day mission. The total mission duration was to be a minimum of 14 days with a design goal to extend the mission to 28 days. An orbital storage period and reactivation for another mission were also considered.

Two alternate concepts were also presented in the project development plan. One study resulted in a configuration where the experiment package was mounted in the LM descent stage engine compartment and extended into the ascent engine-well. The second concept considered the CSM continuously docked to the LM. In this mode the crew would not have to leave the CSM, and emergency re-entry could be accomplished in a short period. This concept allowed a major reduction of LM equipment whose functions could be provided by the CSM. In addition, the CSM could provide more suitable living conditions for the crew.

As the LM/ATM mission evolved, studies were being conducted on the S-IVB spent stage Orbital Workshop. The advantages for longer duration missions by combining the two major AAP missions resulted in a number of clustered configuration concepts. Consideration was given to tethering the LM/ATM to the orbiting cluster by umbilicals carrying cooling fluid, oxygen, and electrical power or by extendable booms. These concepts were subsequently abandoned in favor of hard docking the LM/ATM to one of the Multiple Docking Adapter radial ports. By December 1966, integrating the LM/ATM mission with the S-IVB Spent Stage Experiment had become the primary AAP configuration. The concept for operating the LM/ATM in a free-flying mode was retained as a backup or alternate mission plan.

With the LM/ATM included in the AAP cluster design, EVA was identified as a requirement to retrieve film in order to meet the ATM scientific objectives. The crew would be required to service the ATM experiments by retrieving and replacing the film during EVA's performed at regular intervals throughout each mission. During the EVA systems development, three different systems designs were initiated in response to major cluster configuration changes. All design approaches to the tasks of equipment transfer and workstation location were reconsidered with each change. Although many designs required alteration as the cluster configuration changed, others withstood reexamination and remained essentially unchanged. This reassessment process served to strengthen the final EVA system design for Skylab.

SECTION III. EARLY CLUSTER CONCEPT - EVA EGRESS FROM AM

Upon establishment of a requirement for ATM film retrieval, studies were performed to define the EVA requirements. These included the number, frequency, purpose and duration of tasks to be accomplished. Analyses were then performed to define specific crew tasks and to derive EVA design guidelines and constraints.

The first AAP design guideline specified that EVA would be performed with crew egress and ingress through the AM hatch. This section of the report describes the EVA system development activities performed from early 1967 through mid-1968 while the AM egress guideline was in effect. The initial conceptual studies were accomplished using limited fidelity, inexpensive, "one-g" part-task mockups with a six-degree of freedom mechanical simulator. The objectives of these studies were to investigate ATM canister access, determine optimum locations and configurations for film retrieval workstations, and to develop and evaluate alternative design concepts for crew translation and film transfer.

A. Cluster Configuration

During the period immediately following approval for the combined orbital workshop and LM/ATM missions, the cluster configuration changed rapidly as the various module design concepts evolved. One of the original concepts had a compact solar array arrangement mounted on the ATM and two solar panels deployed from the Spacecraft LM Adapter (SLA) (Figure 6). As the cluster design matured, the compact ATM solar arrays were deleted in favor of a cruciform or "windmill" configuration. Additionally, a set of solar arrays were added to the S-IVB stage replacing the SLA solar panels (Figure 7).

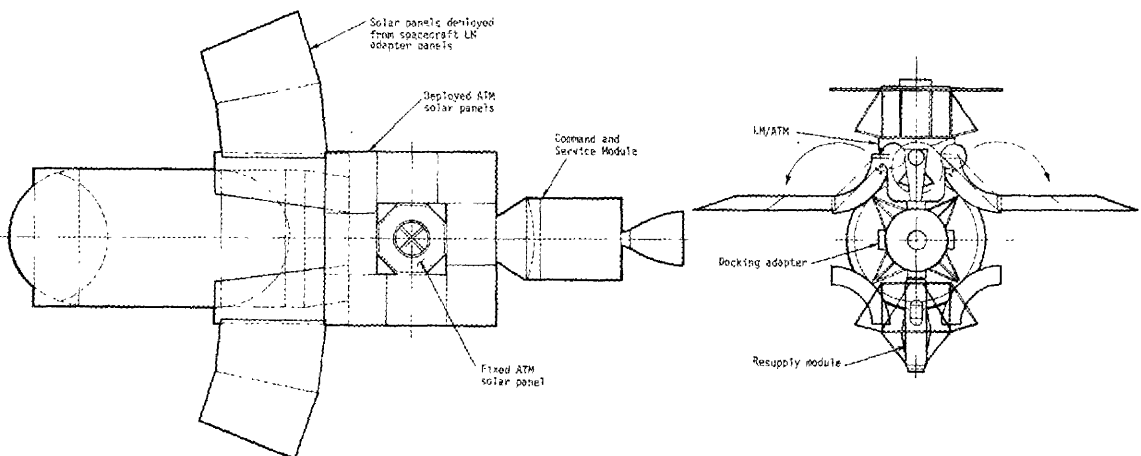

Figure 6. Early Cluster Solar Array Configuration

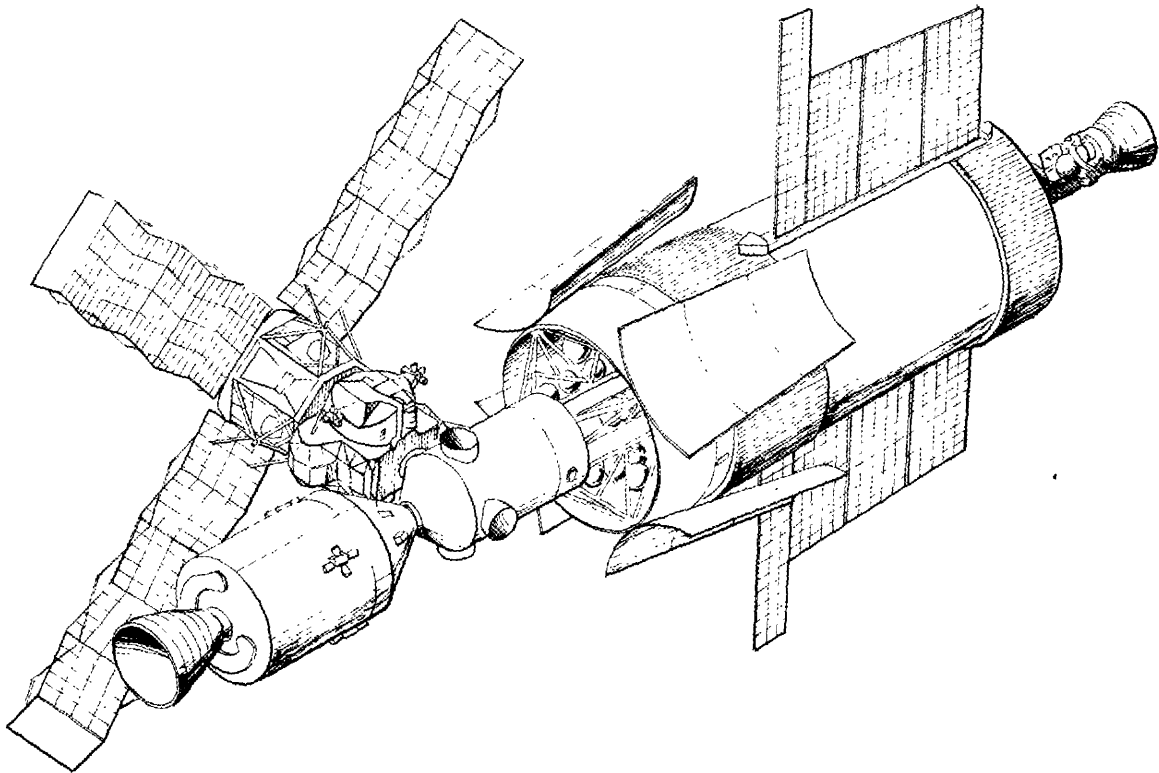

Figure 7. ATM Cruciform Solar Array and S-IVB Stage Solar Array

Subsequent program changes also deleted the RM and LM&SS modules from the clustered workshop missions.

Changes to the LM/ATM configuration affected the earliest film retrieval studies. There were several orientation changes of the LM with respect to the cluster and the ATM as well as changes in the solar array configuration. The addition of thermal protection provisions, a solar shield, and an experiment gimbal system also influenced EVA design concepts. Figure 8 shows one of the LM/ATM configurations of this period along with a view of the canister with the experiment package arrangement.

B. EVA Requirements and Guidelines

The initial studies to establish EVA requirements and guidelines revealed that no adequate specifications were available that directly applied to EVA systems development. At this time there was limited EVA flight experience and man's capabilities in the space environment were uncertain. An intercenter working group was formed to assure continuity in the EVA system design and establish a common base from which to proceed during development of the system. The resulting specifications were included in the AM/ATM EVA Astronaut Support System Requirements and Constraints Document, which served as the original stimulus for EVA system

design and development. As the design matured, the specifications, guidelines and constraints were updated.

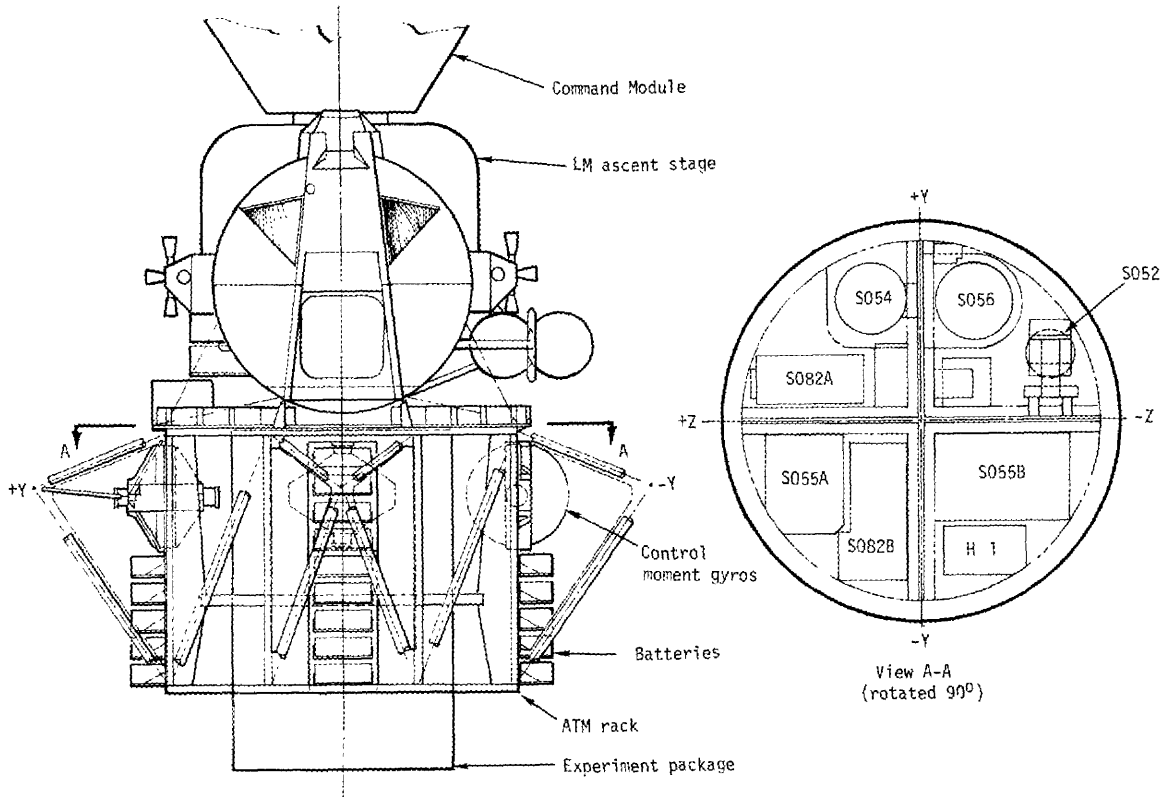

Figure 8. Early LM/ATM Configuration and Experiment Package Arrangement

The following guidelines and constraints were established early in 1967, and were expanded and modified throughout the period extending to mid-1968 while the AM hatch was the primary EVA egress and ingress location. Changes and additions to the original listing are indicated to reflect the growth in the development of the EVA system.

1. Mission

a. A total of four film replacement and retrieval operations were planned. The final EVA would be for retrieval only. EVAs were scheduled for every 14 days of the 56 day mission.

b. Two hours of preparation and one hour of post EVA were required for each EVA (added January 1968).

c. EVAs were to be conducted during both light and dark periods of orbit (added May 1968).

d. Astronaut translation would be allowed during daylight portion of orbit only for the normal mode EVA (added May 1968).

2. Film Cassettes and Stowage

a. There were seven film magazines/cassettes in the ATM canister which required EVA for retrieval and replacement. S052, S054, S056, S083, and H-Alpha 1 magazines would be replaced at the LM end of the canister (S083 added January 1968). S082A, S082B, and S055B magazines would be replaced at the sun end (S055B deleted January 1968).

b. Film cassettes would be color-coded and tethered during replacement operations.

c. Film cassettes would be stowed during launch in either the LM interior or the crew provisions module (added May 1968).

3. Cluster Egress and Ingress

a. EVA egress and ingress would be accomplished from the AM.

b. EVA from the LM would be considered as an alternate method (added January 1968).

4. Life Support System

a. The A6L Block II Apollo pressure suit would be used for EVA (changed to A7L suit in January 1968).

b. An umbilical with 60 foot length capability would be the primary mode of operation.

c. The Lunar Portable Life Support System (PLSS) would be used as a backup mode of operation.

d. The PLSS and Oxygen Purge System (OPS) would be worn as a backup system during umbilical EVA (added January 1968).

e. The umbilical would attach to a Pressure Control Unit (PCU) and contain provisions for oxygen, cooling water, communications, biomedical data, and a mechanical tether (added January 1968).

f. The PLSS or Portable Environmental Control System (PECS) would be used as an alternate mode (added May 1968).

5. Safety

a. EVA astronaut would be continuously monitored.

b. One EVA would be allowed per day and would be performed only when all three crewmen were awake. One crewman would be in the CSM to monitor systems during EVA. One EVA crewman would be located on

standby in the AM (or LM) as a safety backup during the other crewman's film retrieval activity (added January 1968).

c. EVA rest periods would be required at a rate of two minutes after every ten minutes of moderate to moderately heavy activity and two minutes after each period of heavy activity (added January 1968).

d. Translation during EVA would be by use of handrails placed over the structure (modified January 1968).

e. Handrails and other EVA assist hardware would be provided for EVA translation. Translation along handrails required both hands. Maximum translation rate was 2 ft/sec. Nominal rate was 1 ft/sec. (added January 1968 and modified May 1968).

f. Primary mode of translation would be manual using continuous handrails. Semi-automatic or automatic EVA assist hardware would be used only as a possible backup mode of operation (added May 1968).

g. Supplemental lighting would be required for EVA translation and for film retrieval work areas during both daylight and dark portions of the orbit.

h. Utilization of experiment canister roll, pitch and yaw capabilities could be used to aid the crewman in the film replacement task (deleted January 1968).

i. Power to the ATM canister during EVA would be limited to gimbal roll control (added January 1968).

j. ATM gimbal ring would be manually locked during film retrieval and replacement operations (added January 1968).

C. Workstations and Canister Access

The original ATM experiment package configuration required retrieval of four film packages located in the side of the canister and three film packages at the sun end. Preliminary investigations revealed that the canister roll capability could be used to bring the camera access doors to the crewman positioned at a fixed worksite rather than having the EVA crewman maneuver to each camera. Work then began on developing two LM/ATM workstations to provide access to the film packages. These were named the "LM-end workstation" and the "sun-end workstation".

1. LM-end Workstation. Studies and simulations were conducted to investigate access to the four film magazines in the side of the ATM canister and to establish an LM-end workstation design. The ATM quadrant between the -Z and +Y axes was determined to be the most acceptable location for the LM-end workstation (Figure 8). Design concepts were formulated to identify the hardware requirements for assisting the crewman in maneuvering to and entering the workstation, for providing body

restraints while performing the film magazine removal and replacement task, and for access provisions to the instruments within the canister. The Gemini-type "dutch shoe" foot restraints were to be considered as the primary method of restraining the crewman's body at the workstation (Figure 9). The configuration of the ATM rack, canister and solar arrays posed a number of problems and constraints that required resolution. One constraint required electrical disconnect and mechanical locks on the canister gimbals and a mechanical lock on the solar panels for safety during the film retrieval operation. Access to the canister also required removal of a diagonal spar or strut which provided structural rigidity to the rack structure for launch and docking loads.

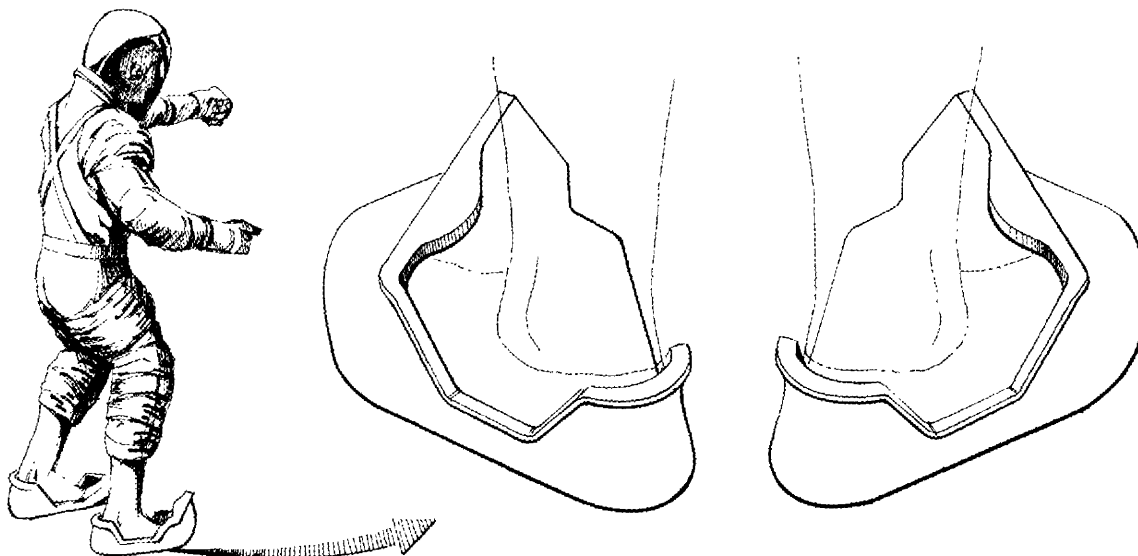

Figure 9. Gemini-Type Foot Restraints (Dutch Shoes)

By June 1967, the LM/ATM and LM-end workstation design had evolved to the configuration shown in Figures 10 and 11. The workstation consisted of a platform attached to the rack structure with a pair of Gemini-type foot restraints. The required mechanical locks, a gimbal rotation switch, tether attach points, floodlights, a guard rail, and provisions for moving the diagonal strut were also incorporated. Mockups of this basic design were built and used to analyze and develop film retrieval procedures and evaluate the hardware concepts for the task in one-g simulations with a multiple degree-of-freedom mechanical simulator.

On August 15, 1967, an astronaut review of the LM-end workstation concept was held to obtain concurrence on the feasibility of the concept, to evaluate the crew interface for the existing hardware and determine requirements for additional restraints and stability equipment. The review progressed through a shirtsleeve walk-through of the task sequence, a one-g pressure suited sequence, and finally, a work session using the six degree-of-freedom mechanical simulator. The primary problem areas

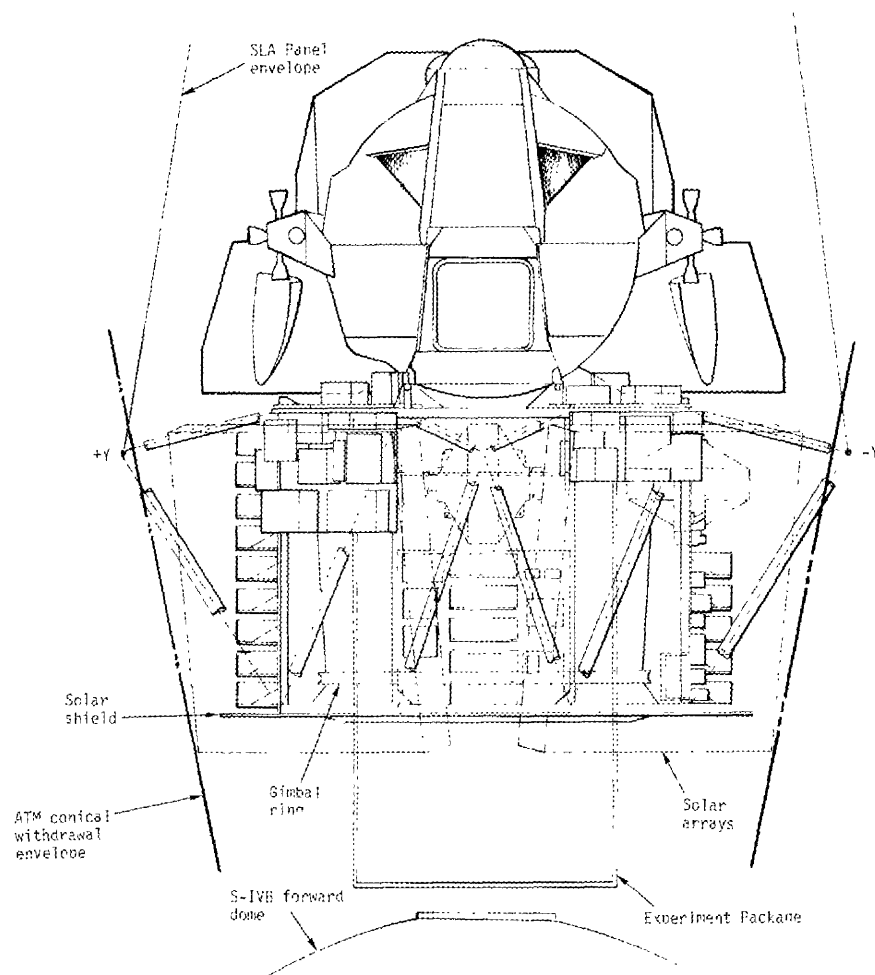

Figure 10. LM/ATM Configuration (June 1967)

identified during the review concerned film package visibility, location and canister access door size and location in relation to the crew work position. Two of the film magazines (H-Alpha 1 and S056) were not within the crewman's reach envelope and would have to be moved. Recommendations were also made to reconfigure the workstation guardrail, provide a continuous translation rail for entry into the workstation, provide a single foot restraint above the platform to aid in removing and stowing the diagonal strut, and define film magazine transfer techniques and temporary stowage provisions. The basic workstation concept was accepted and work proceeded on refining the design and increasing the mockup fidelity for further simulation studies.

The solar panel supporting structure and actuation hardware were still in a definition phase at this time, which delayed design efforts for both the LM-end and the sun-end workstations because of an anticipated hardware impingement problem. Difficulties with access to the film

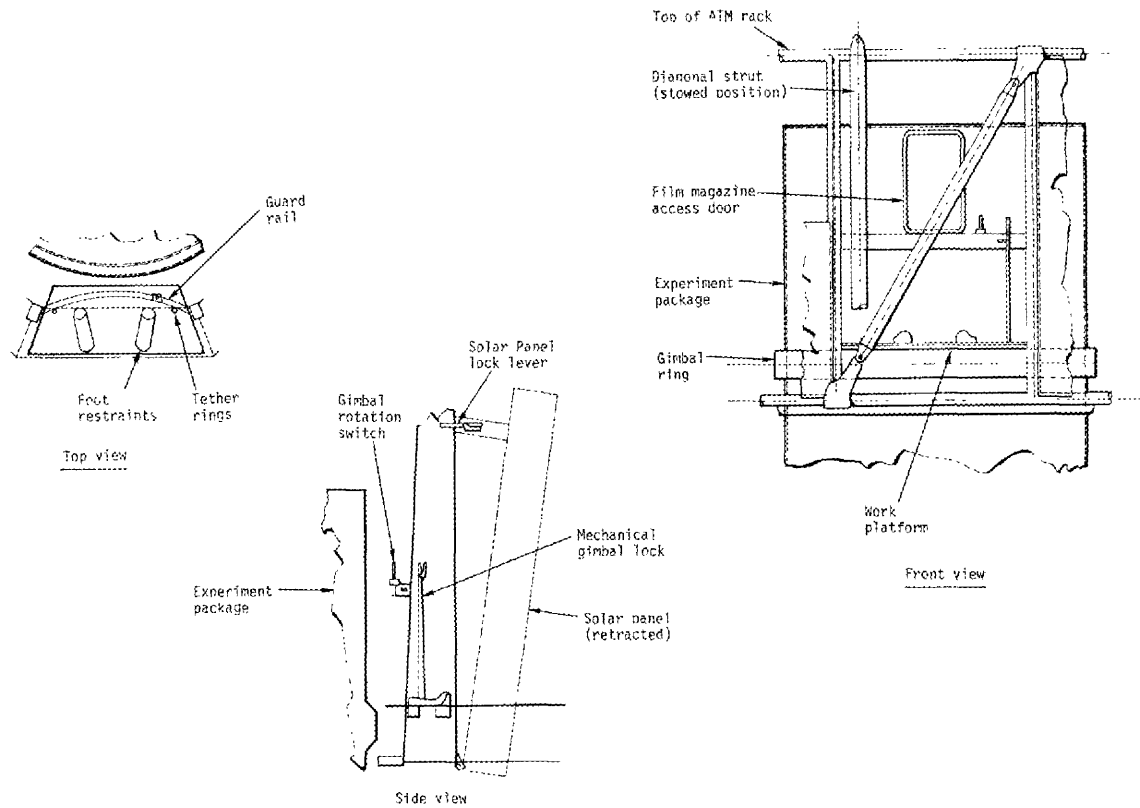

Figure 11. LM-End Workstation Configuration

magazines within the canister also resulted in a number of investigations to establish canister roll requirements for location of the sun end workstation and access door locations at the LM end. Alleviation of the H-Alpha 1 film magazine retrieval problem required a change in the $\pm 95^\circ$ canister roll capability. It was recommended that the magazine retrieval direction be changed as shown in Figure 12. This change required an additional 25 degrees of canister rotation toward the -Y axis. The extension of the limits to 120 degrees was not considered a constraint, but prompted further investigations into the advantages of using maximum canister rotation to facilitate the film removal and replacement task. In addition to the solar panel and canister configuration changes, the shape and location of the solar shield underwent an evolutionary process which also influenced the workstation design concepts.

When preliminary ATM solar array support structural details had been defined, simulation activities on the LM-end workstation concept resumed. A mockup of the solar array support structure was fabricated and attached to the LM-end workstation mockup. In late December 1967, the film retrieval task was performed using the six degree-of-freedom simulator. This task was performed to isolate potential problem areas

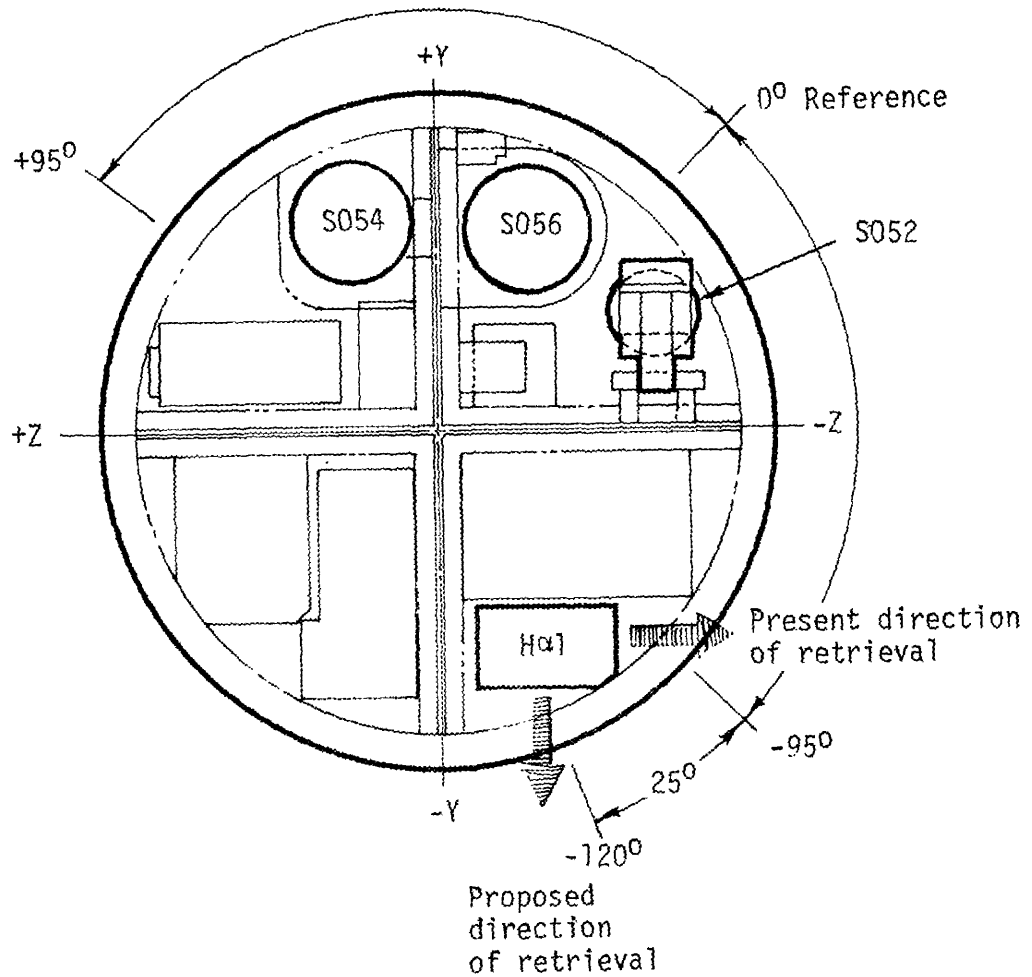

Figure 12. Canister Rotation Requirement for H-Alpha 1 Film Magazine Retrieval

affecting crew safety and task performance with the workstation and solar array support structure interface. During workstation ingress and egress, diagonal strut stowage, and film replacement tasks, the crewman frequently struck the cross beam of the solar array mounting structure with his helmet and other pressure suit components. Release and stowage of the diagonal strut was found to be extremely difficult. With the strut in a stowed position, the horizontal workspace was decreased to below acceptable limits and manipulation of the roll controls was inadequate because the control panel was partially obscured by the strut. Figure 13 illustrates the interference and access problems. An analysis of the simulation activities resulted in recommendations that the cross member beam be raised and that sufficient structure be added to the ATM rack to permit elimination of the diagonal strut.

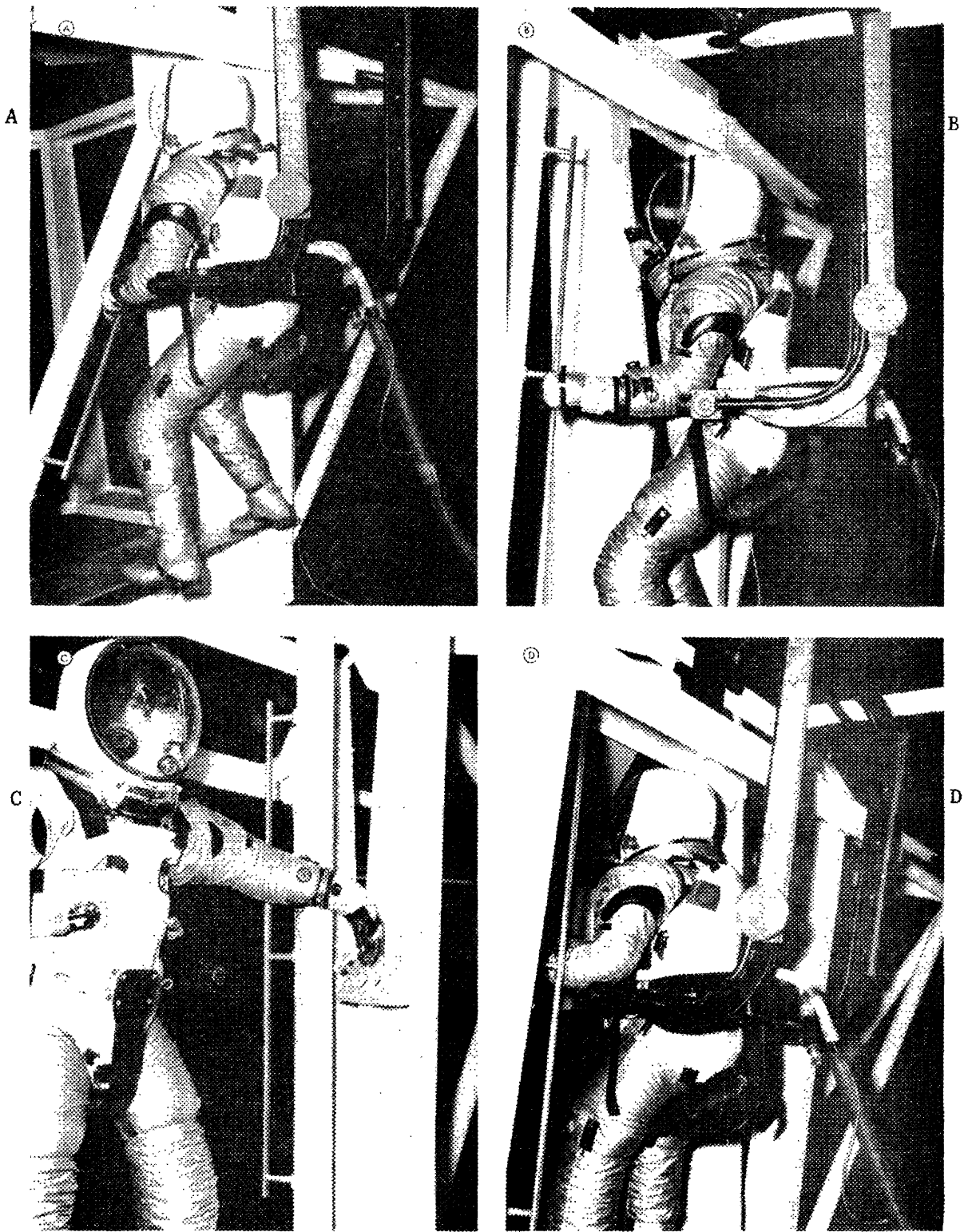

Figure 13. LM-End Workstation Simulation Showing Structural Interference

Simulation activities continued during January 1968 using higher fidelity mockups to resolve the structural interference and spar retraction problems. These activities also verified LM-end workstation crew-assist and film magazine access hardware. Figure 14 illustrates the

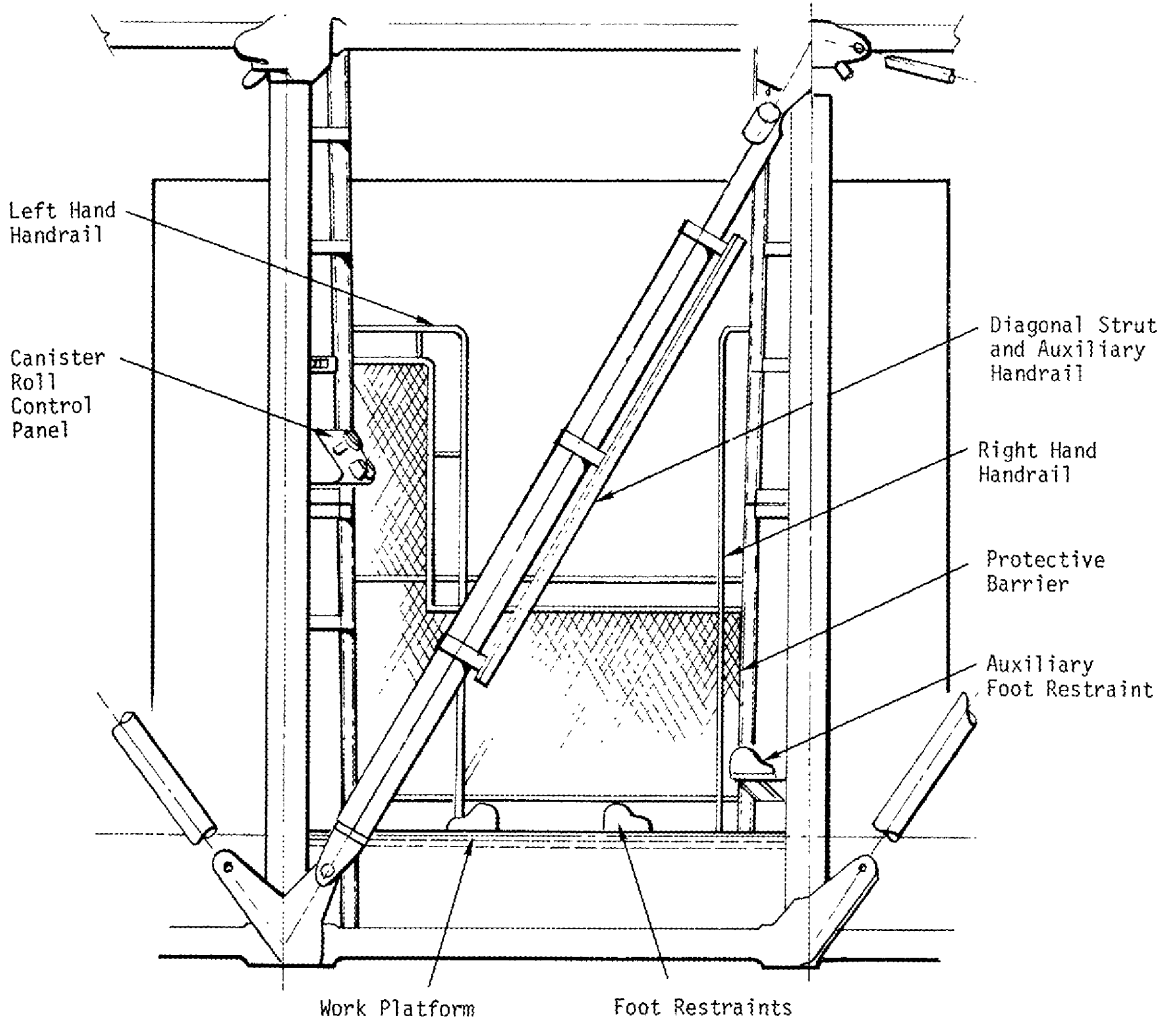

Figure 14. LM-End Workstation Evolution

workstation configuration and Figure 15 shows the task sequence for access to the workstation as performed using the six degree-of-freedom simulator. The crewman engaged and verified the solar panel lock, translated around the solar array structure, manually released and stowed the diagonal strut with use of the auxiliary foot restraint and maneuvered into the workstation foot restraints. Once stabilized, he rotated the canister from the roll control panel to bring the access door into position for film magazine removal. Figure 16 shows the crewman, with the PLSS and OPS backpack attached, removing a film magazine from the canister.

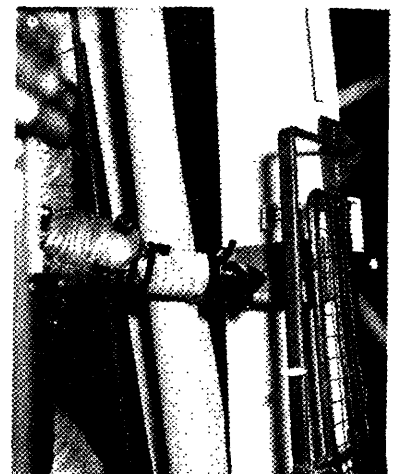
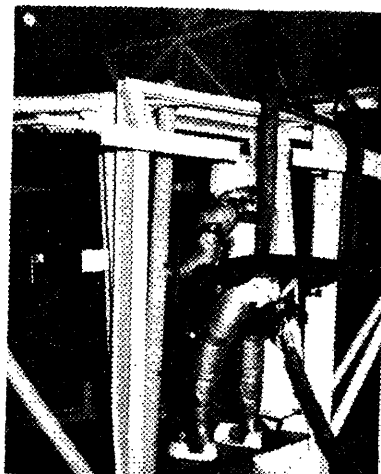
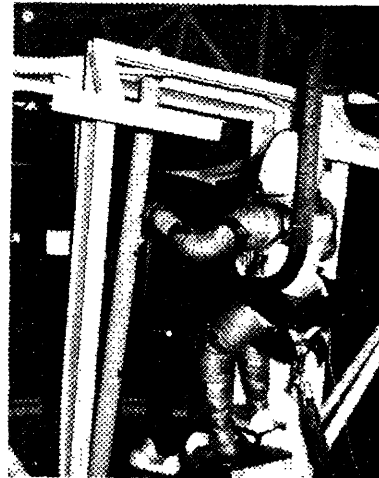
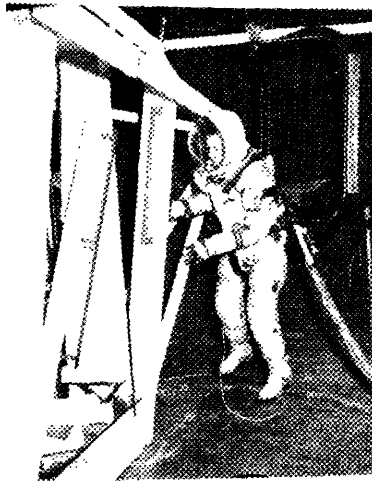
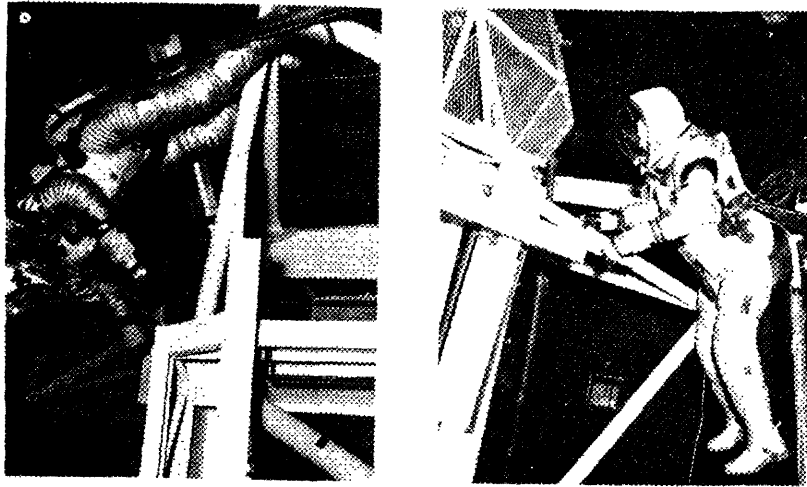

Figure 15. LM-End Workstation Ingress

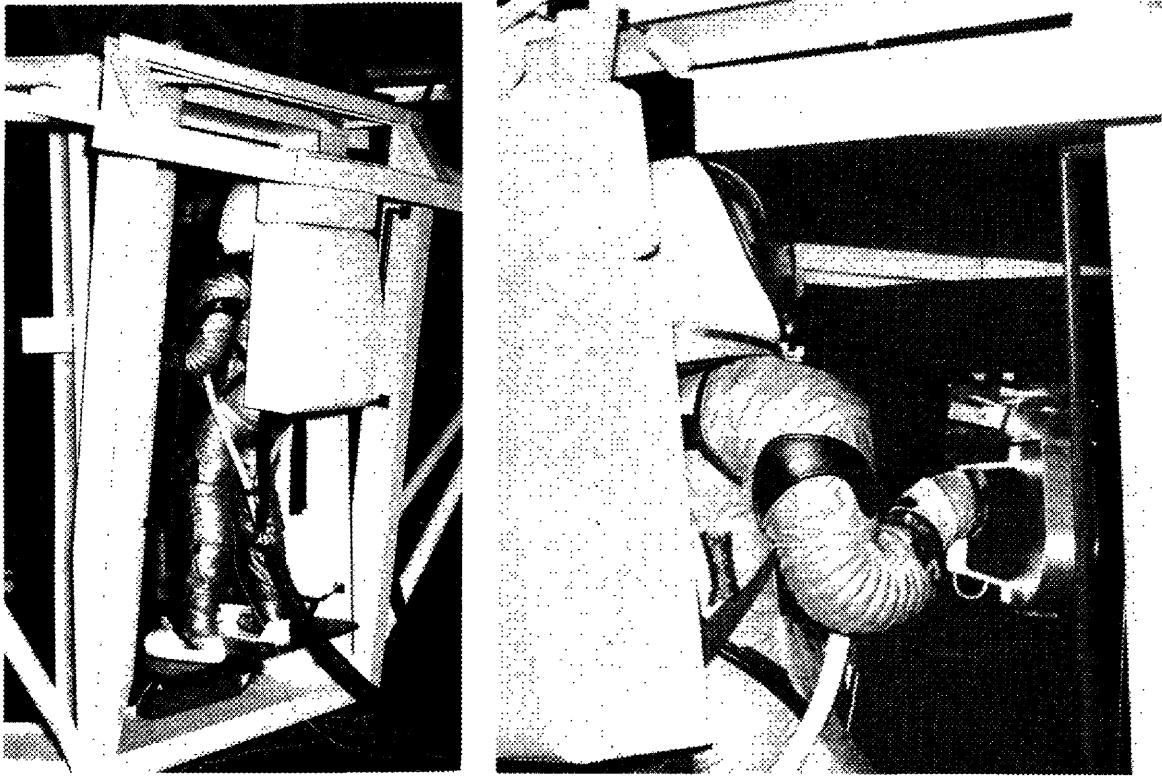

Figure 16. LM-End Film Magazine Retrieval

By February 1968, the development activities on the workstations had resulted in specific design guidelines to facilitate removal and replacement of the film magazines by the crewman. The force, torque and mobility capabilities of the EVA astronaut were baselined and the following guidelines were identified to the experimenters for detail design implementation:

- a. The same handle and locking lever approach should be incorporated, if possible, on all experiments.
- b. The film magazine should be tethered during retrieval and replacement. A tether ring located at the bottom of the film magazine handle is recommended. The diameter of the tether ring opening should be approximately 1 1/2 inches.
- c. The latching mechanism should be designed for one-handed operation.
- d. A direct push or pull by the astronaut, rather than torques, side, or vertical forces would be used to actuate the latching devices.

e. Closed and latched positioning of the magazine would be required. Latched position would be confirmed at the workstation, and mechanical means of confirmation would be used. Electrical indication of latched or unlatched condition would not be acceptable.

f. A detent pin would be provided for launch vibration level stowage.

g. Guide rails would be provided which required the astronaut to perform only coarse location of the magazine on insertion. The guide rails would prevent binding during insertion to the position of precisely located engagement. Initial entrance into the guide rails would be as near the astronaut as possible,

h. Clear visibility of engagement of camera with guide rails would be provided.

i. Special attention would be given to electrical connector design to accommodate connecting and disconnecting forces applied through the latching mechanism.

j. The handle dimensions follow:

(1) Handle length - 5.0 inches, minimum.

(2) Handle crosssection - 1.25 inches by 0.55 inch.

(3) Clearance between handle and mounting surface - 2.5 inches, minimum.

(4) Angle of handle axis to film magazine - 0 to -20 degrees.

As the film magazine interface design continued, the conceptual development of the sun end and LM-end workstations was proceeding toward selection of a feasible design. Many factors combined to complicate the task, but the main difficulty was the seemingly contradictory requirements for optimization of each workstation, in terms of reach and visibility, not just individually, but with respect to other workstations and, in particular, with respect to the crew and cargo transfer system. Interactions between workstations and transfer systems, especially in the "domino effects" of small changes became extremely difficult to analytically predict. Therefore, frequent suited and shirtsleeve simulations, in one g and zero g, began to play an increasing role in the conceptual design of the film retrieval system. Initial development work was performed in one g before the creation of detailed drawings. When a concept appeared promising the development was continued in zero g simulations using neutral buoyancy techniques in the MSFC neutral buoyancy facility.

Continued problems with manual retraction of the LM-end workstation diagonal strut prompted a trade-off study of the potential options. Further analyses had revealed that the ATM rack could not support anticipated launch loads without some type of structural member. Replacing the single strut with two struts was shown in simulation to interface with the film retrieval operation besides adding 75 pounds more weight than the single strut (Figure 17). The single, retractable strut was finally retained, but a pyrotechnic pin removal device and a retraction mechanism that would automatically retract the strut before EVA were added. The solar panel support structure interference had been minimized by raising the cross beam and lowering the canister and foot restraint platform. As a result the auxiliary foot restraint was removed. The canister roll control system and alignment techniques were developed to provide a coarse rate of 7 degrees/sec and a fine rate of 0.7 degrees/sec within the redefined -120 to +110 degree canister roll capability. Accurate positioning of the canister at each film access door could be achieved within ± 1 degree. The manual gimbal lock control provided five lock positions for LM end film retrieval and one position for sun end film retrieval. The five canister door opening sizes and latches were optimum for astronaut reach and visual requirements and the film magazines were compatible with the capabilities of the pressure suited astronaut. By the summer of 1968, the LM-end workstation concept was ready for design verification testing in zero g by neutral buoyancy simulation and in KC-135 flights.

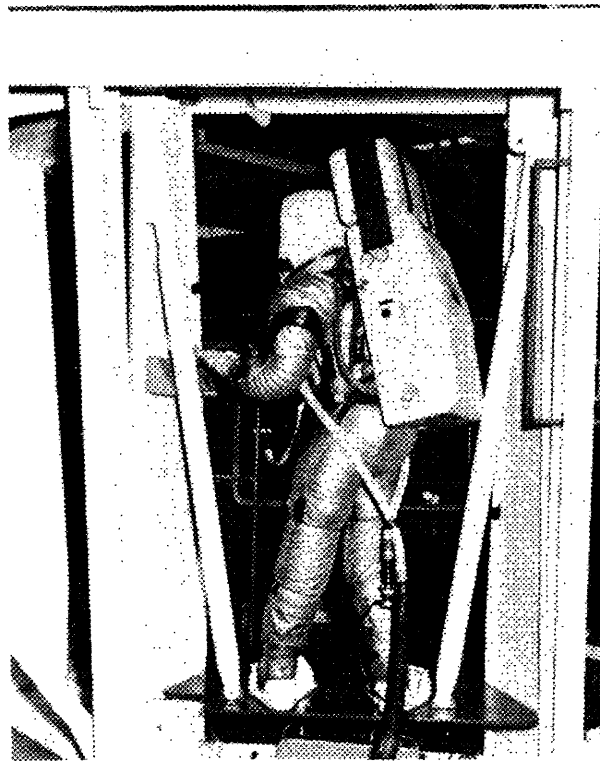

Figure 17. LM-End Workstation with Two Diagonal Struts

2. Sun-End Workstation. The earliest ATM sun end development simulations were conducted during the period from March through June in 1967, using a full-scale mockup of the ATM rack and a multiple degree-of-freedom mechanical zero-g simulator. The objectives of these preliminary simulations were to investigate access to the film magazines in the sun end of the ATM canister, to establish the feasibility of manual film magazine retrieval from the sun end of the ATM, to identify EVA support equipment required to accomplish the magazine handling operation (for example: film magazine storage and transfer, crew and equipment tethers and tether attach points, restraints, accessibility and work envelopes, and lighting requirements), and to identify the tasks and task sequence required for film retrieval.

Two techniques and workstation design concepts for film retrieval were investigated: sun end front access and sun end side access. Results indicated that either workstation configuration was practical for retrieving at least one film magazine, but it was not possible to retrieve all three magazines from either workstation because of the location of the magazines within the canister and the design of the scientific instruments. As a secondary objective, the simulations also considered alternative methods of gaining access to the canister for film retrieval. Sliding doors, single-hinged hatches and double-hinged hatches on the canister access opening were evaluated, and operational configurations of the access doors, door latches and door hinges or rotational devices were proposed.

At a design review meeting held on June 19, 1967 at MSFC, a trade-off study of side versus front access for sun end film retrieval indicated that front end retrieval was superior. The most important considerations were that telescope redesign would be required to make the S055B film magazine accessible from the side, and that the greater distance to be maneuvered with side access as compared with front access posed potential safety hazards. To accomplish film retrieval using only one workstation at the sun end, the design of a film magazine mate and demate mechanism was proposed to solve the reach problem. The mechanism would have to release the film magazine from the scientific instrument and position it near the canister access opening within reach of the crewman. The same mechanism would be used to install the unexposed film magazines in the instrument. This concept was deleted in favor of a simple folding handle attached to the film magazines. Other considerations included the addition of a solar shield structure in the workstation area and requirements for temporary film magazine storage locations, crew and film magazine tethers and tether attach points, and body restraints.

Follow-on studies were conducted during July and August of 1967 to develop the sun end, front access workstation and to evaluate through simulation the feasibility of film retrieval without tethering the crewman to the ATM canister, the suitability of using the Gemini-type foot restraints for body restraint, and methods for erecting and stowing the workstation. The requirements for stowing the workstation and crew body and equipment restraints were necessary because nothing was permitted

to come in contact with thermal surfaces on the exterior of the ATM canister or with the solar panels. The information gained during these early sun end investigations contributed to the establishment of design requirements and guidelines to ensure compatibility with the ATM rack and canister design.

During the latter months of 1967, analyses of translation requirements revealed that designing a feasible concept for crew translation would be extremely difficult due to the location of the sun end workstation at the ATM +Z axis, which was 135 degrees around the canister from the LM-end workstation. Changes to the experiment package deleted the S055B instrument, leaving only the S082A and S082B cameras requiring access from the sun end. The S055B was replaced by an S083 camera that would require film retrieval and replacement from the LM end. The translation studies also recognized that maneuvering through the solar panels was a critical problem. Because of these factors, it was recommended that the sun end workstation be located at the ATM +Y axis; the translation distance would be shorter and the EVA route between the workstations less obstructed and more direct. Analysis of concepts for integrating the translation devices and solar shield with the sun end workstation was also recommended.

The following functional design requirements and constraints were considered basic to the development of the new sun end film retrieval concepts:

- a. The workstation aid would be capable of being deployed or positioned easily from a stowed position to an operational position and then returned to a stowed position.
- b. Deployment or positioning of the workstation aid would be operable with use of Apollo thermal gloves.
- c. Mobility and stability capability would be provided on the retrieval workstation. Such aids would allow the astronaut to use both hands simultaneously.
- d. Tools would not be required to activate the device used to deploy or position the film retrieval workstation.
- e. The workstation would provide easy access to film magazine locations of experiments S082A and S082B and would not interfere with functioning of the experiment apertures or star and sun sensors at the sun end of the canister.
- f. Film magazines would have temporary stowage located for easy access to the astronaut. The stowage area would accommodate a minimum of two magazines.

These design requirements eliminated those concepts, such as shown in Figure 18, that involved permanent mounting of workstation structural members to the sun-end solar shield surfaces. The ideas presented for film magazine stowage and sliding foot restraints were, however, reflected in later concepts. In December 1967, a trade-off study of three proposed concepts was completed. This study resulted in another concept designed to overcome human factors problems revealed in the evaluation of the three concepts. Since the concepts were not named, they were designated as concepts I, II and III. The study was based on the above design requirements and the following constraints, which had evolved from ATM experiment design activities during the preceding few months.

- a. Retrieval workstation could physically contact the thermal surfaces of the ATM solar shield and solar panels.
- b. Experiment thermal control requirements prohibited the mounting of any structures to the canister surface.
- c. The experiment optical systems would not be exposed to any extraneous incident or back-scattering illumination during experiment operation.

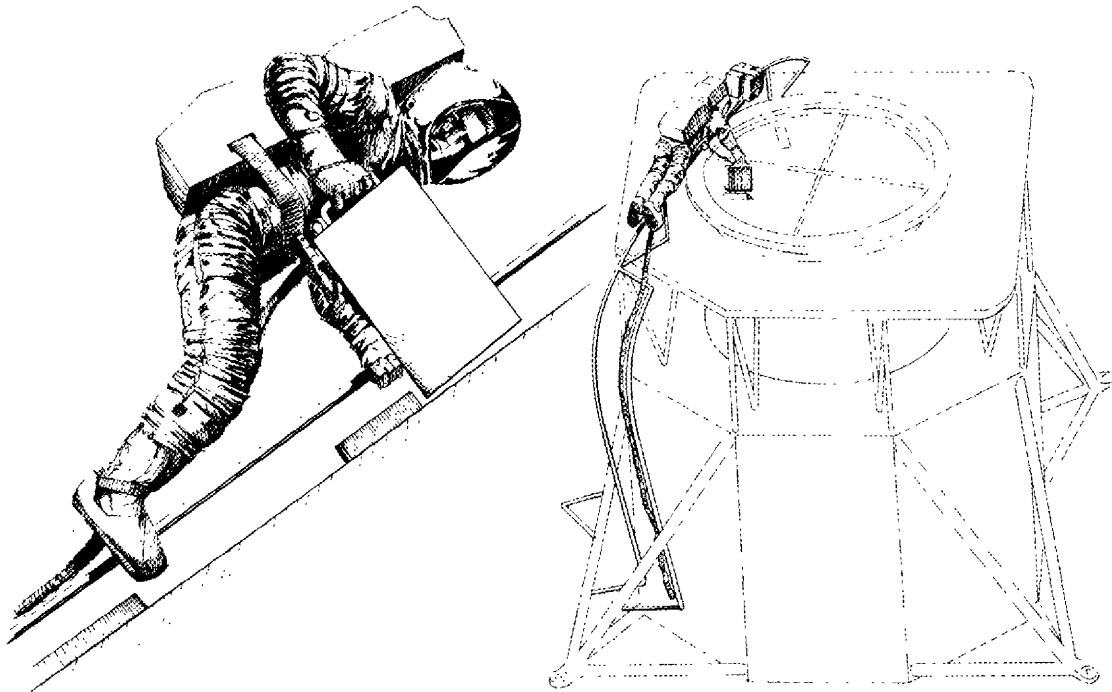

Figure 18. Single Rail Sun-End Workstation Mounted on ATM Solar Shield

d. No device or structure could protrude beyond the sun end of the canister while in the stowed position.

e. The retrieval workstation would be the only means of supporting the astronaut and film magazines.

Concept I consisted of two parallel translation rails with umbilical guides located between the rails at intervals of approximately two feet. Also located between the rails was a supporting tray for film magazines and the roll-control switch box. In translating, the astronaut would push the umbilical past the retainers into the guides as he passed over them. The supporting film magazine tray would be pushed along the rails ahead of the astronaut. For access to the sun end of the canister, the astronaut would unlock the retrieval workstation and rotate it until it locked into place over the sun end. After translating around the bend in the rails the astronaut would insert his feet into foot restraints and operate the roll-control switch, rotating the canister into position for magazine replacement. Upon completion of the task, the astronaut would release his feet from the foot restraints and back down the translation rails, stowing the retrieval workstation by rotating toward the translation rails and locking the device into the stowed position.

Concept II consisted of a travel and supporting ring located approximately three feet from and surrounding the sun end of the canister. The travel and supporting ring was structurally supported to the under side of the ATM rack and the ring. The retrieval workstation was a circular segment stowed along the supporting ring. The circular segment was pivoted around a movable joint and could be locked in place. Attached to this circular segment were two foldable translation rails with the umbilical guides and a support tray for the film cassettes and roll-control switch box. The translation rails formed an extension of the translation rails which ran from the sun end to the LM-end retrieval station. The retrieval workstation was deployed around the travel and support ring and the canister by walking around the ring while holding onto the retrieval workstation. Canister rotation did not have to be performed because the travel and supporting ring encircled the canister.

Concept III consisted of Gemini-type foot restraints, a waist-support bar, and tubular handrails structurally supported on the ATM rack structure. The tubular handrail was located on the lower edge of the horizontal rack structure to provide hand and upper-body support during positioning and reaching movements. The waist-support bar was used for stabilization while positioning into foot restraints. The film-retrieval workstation was rotated and retracted for stowage while not in use.

The basic disadvantages of the three concepts were associated with translation between the solar arrays, with reaching into the canister for film retrieval, with deployment of the device interfacing with the solar shield, and with provisions for temporary film storage devices. Also, the stowage position of the devices interfered with optical systems

and thermal control requirements. Concept IV, resulting from these trade-off studies, seemed to fulfill many of the requirements for a feasible design.

The concept IV device would straddle the translation rail located between the LM-end workstation and the sun end (Figure 19). The ladder type telescoping part of the workstation aid was stowed parallel to the permanently oriented nontelesoping part of the workstation aid. In the stowed position, the telescoping device would not extend above the solar arrays or the canister. To deploy the workstation aid, the astronaut would unlatch and extend the telescoping ladder part of the workstation aid (Step 1), and revolve the hinged ladder until it was a fixed right-angle position located directly above and parallel to the canister (Step 2). The astronaut would then extend and lock the telescoping ladder over the canister (Step 3) to the desired length. The astronaut would then climb onto the ladder, affix body restraints and retrieve the film magazines. He would then retract the ladder device until it returned to its original stowage position parallel and against the nontelesoping part of the device.

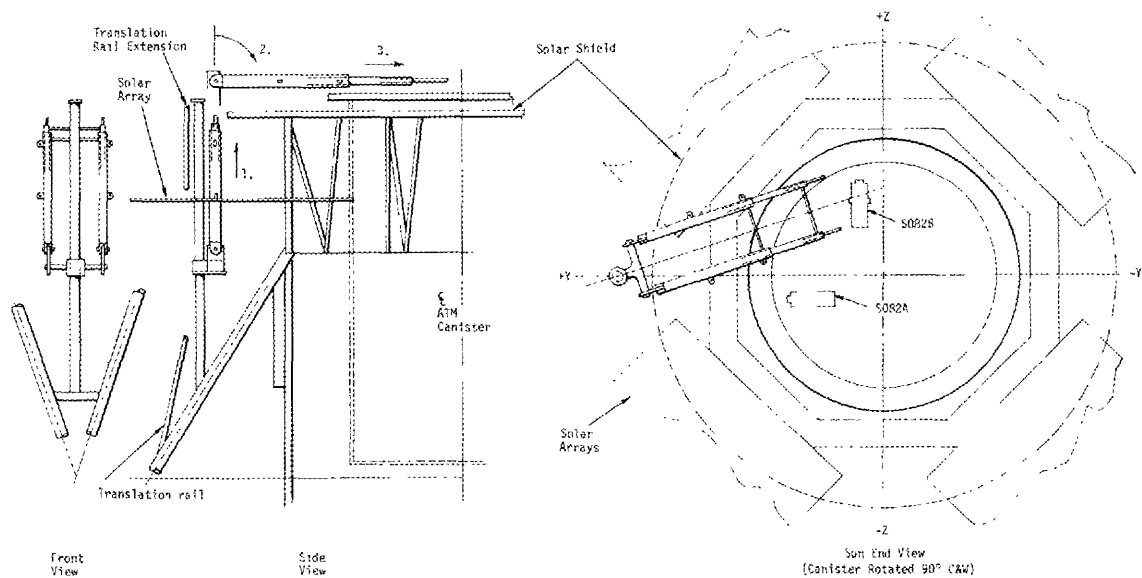

Figure 19. Ladder-Type, Telescoping Workstation (Concept IV)

Refinements of the original concept to integrate crew translation, cargo transfer and workstation hardware were included as shown in Figure 20. Extension of the translation rail over the solar shield and the addition of film magazine racks to the foot restraints provided the crewman with a combined mobility aid and cargo transfer device from the LM-end to the sun end workstation device. The problem of maneuvering the crewman and film magazines safely through the solar arrays to the sun end without mounting hardware to the solar shield or canister seemed to be solved.

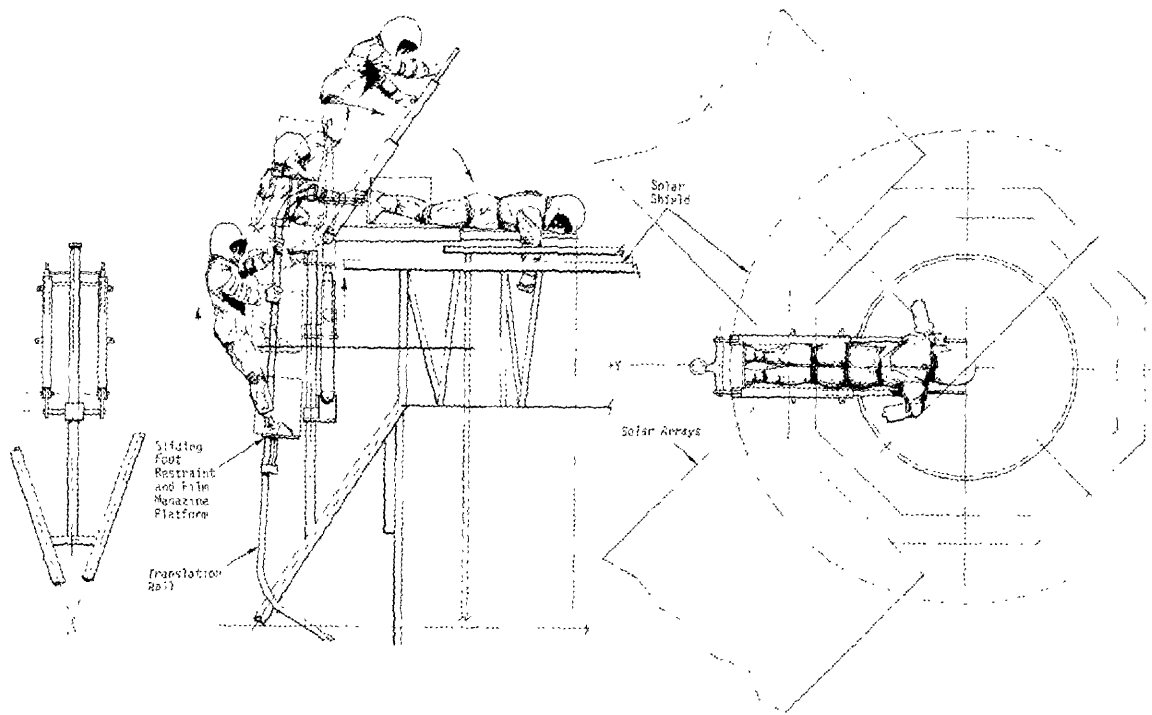

Figure 20. Combined Translation Rail and Ladder-Type Workstation (Concept IV)

The basic idea presented by Concept IV resulted in a number of similar concepts that incorporated various methods of deploying the workstation. Some of the concepts, as shown in Figure 21, included motor-driven devices to assist the crewman in erecting the workstation. Most of these ideas never progressed beyond a simple sketch and are presented here to reflect the thoughts of the designers in finding solutions to the workstation design problem. One of the reasons for eliminating some of these designs was that some hardware extended outside of the ATM withdrawal envelope (Figure 10). Others were simply too complex and would have required unjustifiable effort to develop a reliable, lightweight design.

The concurrent studies and simulations on translation and transfer devices had centered around a manual translation handrail, incorporating a sliding foot restraint platform and sliding film magazine stowage racks. These studies also considered combining the translation and workstation devices into an integrated concept. Various continuous rail concepts were proposed that provided the EVA crewman an unbroken path between the AM hatch and the sun-end workstation. Figure 22 illustrates one of the sliding workstation platform and rail concepts, which was rejected because of the large bend radius required in the rail for directional changes.

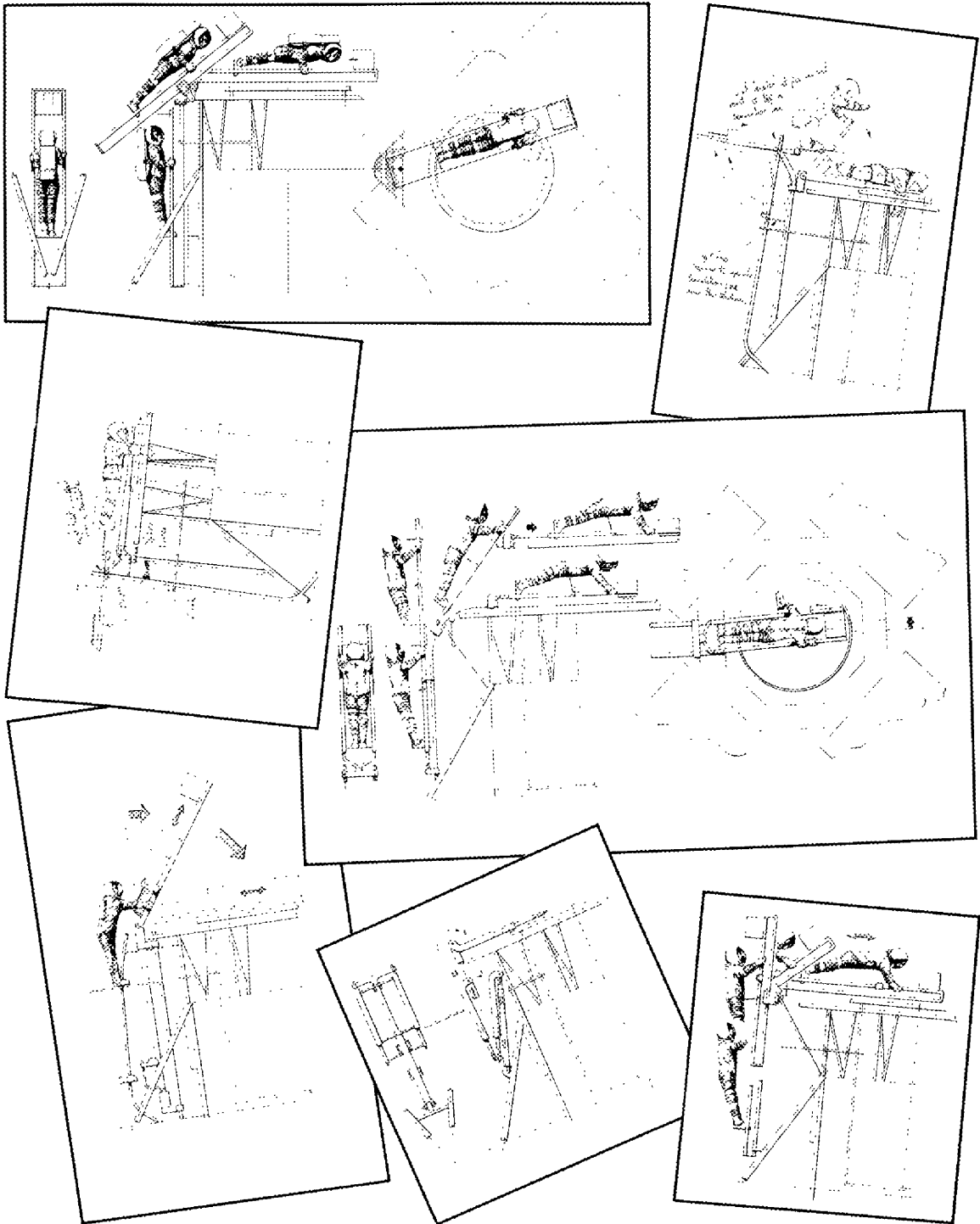

Figure 21. Variations of Sun-End Workstation Concept IV

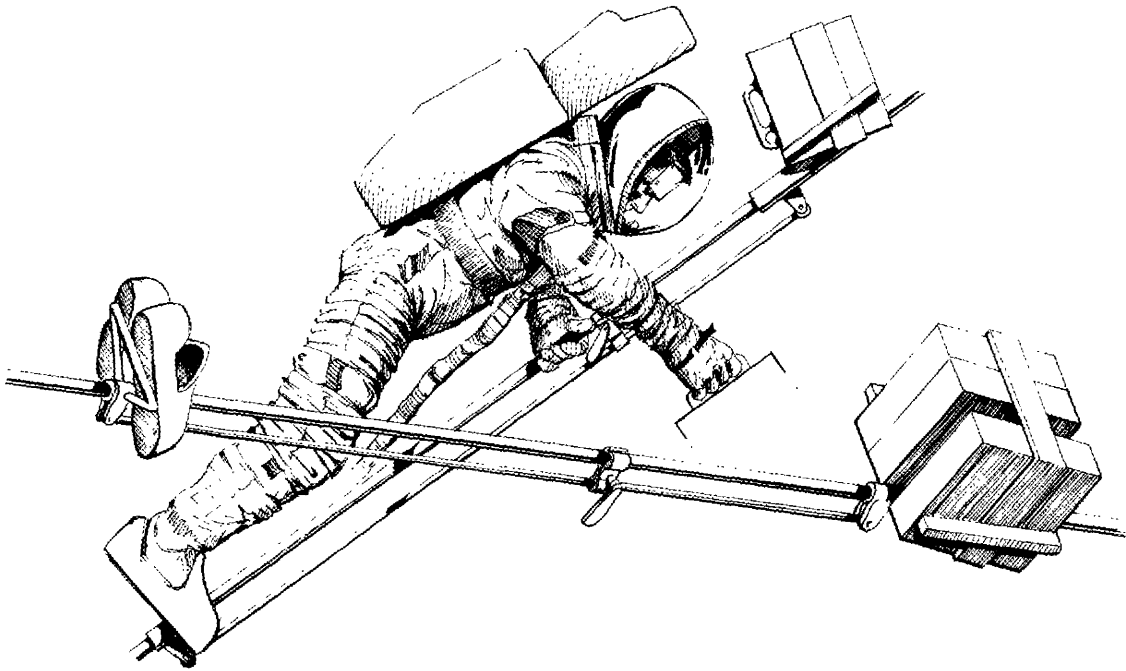

Figure 22. Single Translation Rail, Sliding Workstation Concept

Because of the number of proposed concepts and new techniques, sun-end workstation simulations continued under the following guidelines:

- a. Start with the simplest, single rail concept and add complexity as the task requires.
- b. If two rails are required, determine the optimum separation distance. The Gemini foot restraints require rails spaced greater than 21 inches apart. Also determine if ladder type rungs are required and necessary spacing.
- c. Determine the best placement for film magazine holder.
- d. Determine if both S082A and S082B magazines can be replaced from one position or if the crewman must move between the two.
- e. Determine the angle the workstation must be placed in relation to the canister and if rotation of the workstation is required.
- f. Determine the optimum height of the workstation above the canister.
- g. Determine if the canister gimbal roll requirements need to be increased.

During the spring of 1968, many tests were conducted to investigate the various techniques and requirements and establish feasible workstation concepts.

The earliest of these tests was conducted with a single rail mounted above the canister surface that could be easily relocated to vary the standoff distance and to simulate various degrees of canister rotation. Gemini-type foot restraints and a film magazine container were mounted to slide along the rail. The test subject was suited and pressurized and performed the task in the six degree-of-freedom simulator. Figure 23 shows the test configuration and some of the problems encountered. Considerable difficulty was experienced with the foot restraints and with the crewman's helmet and face plate contacting the rail, stowage container and canister access doors. Any attempt to move off the rail axis to extend his reach resulted in foot disengagement from the foot restraints. His knees also contacted the canister surface and the film magazines were repeatedly bumped against the face of the canister during retrieval. Although the canister magazine locations were within the reach envelope, film magazine retrieval was extremely difficult, especially with the S082B elongated handle, which required the subject to release his hand from the rail and back away for the magazine to clear the canister aperture.

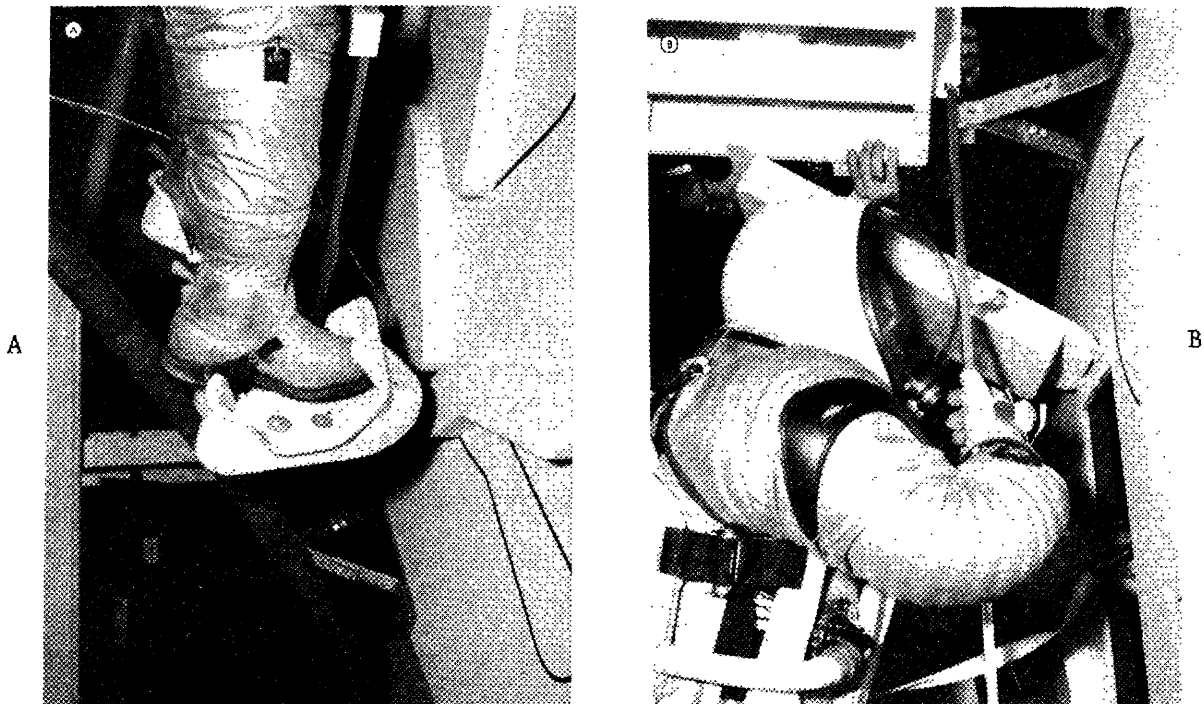

Figure 23. Single Rail Sun End Film Retrieval Simulation

The test fixture was modified to a dual, tubular rail platform, attached to the single translation rail (Figure 24) and oriented to lie between the canister access doors with the canister rotated 80 degrees clockwise. Instead of a toe-out position, the foot restraints were mounted to provide a slight toe-in effect to reduce the tendency of foot disengagement during lateral movement. In addition, Velcro material was added to the heel area for further security. The crewman could move the workstation right or left to facilitate film retrieval. High fidelity S082A and S082B film magazines were made available, complete with guide rail and latching handles.

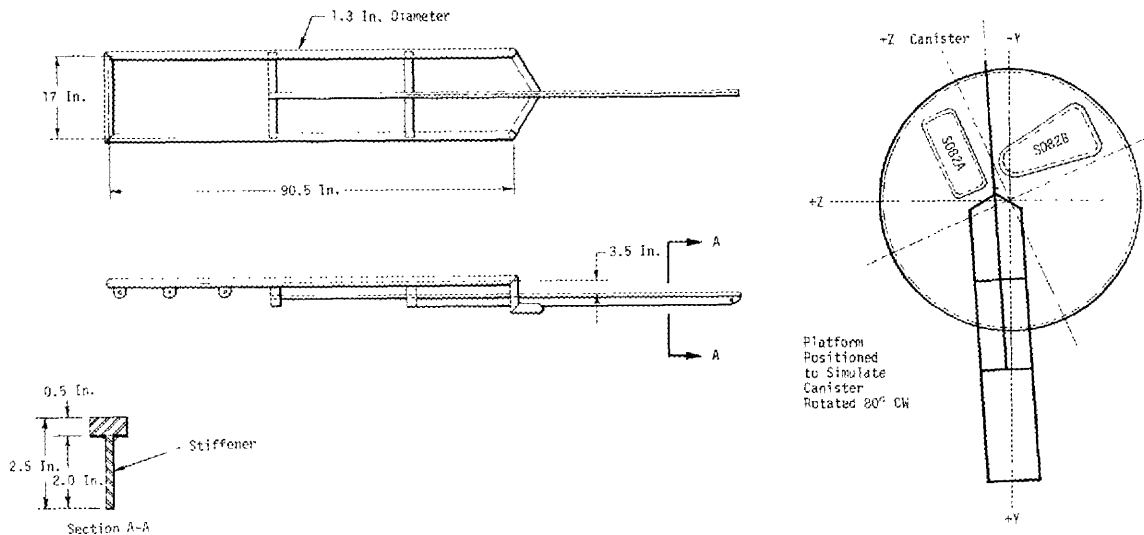

Figure 24, Dual Rail Workstation Platform Test Configuration

Initial simulations with this configuration revealed that the crewman still experienced difficulty with his feet coming out of the foot restraints or his knees contacting the canister surface. The foot platform would bind on the dual rails during translation and handhold areas were inadequate. A number of film magazine modifications, canister door size changes, and hinge relocations were recommended. The workstation was further modified to eliminate the 90 degree bend in the dual rails and provide an extension of the rails for handholds. The workstation was mounted in the vertical plane from the ATM +Y axis across the sun end canister face toward the -Y axis. The dual rails were elevated 9 inches above the canister (Figure 25), while the single rail, which carried a sliding waist tether ring and film magazine stowage container, was elevated 4 inches above the canister surface.

In addition to the 80 degree clockwise canister rotation used in the previous test (Figure 26), 95 degree and 112 degree counterclockwise canister roll positions were investigated for the first time in the final series of simulations. During the tests, the crewman had difficulty

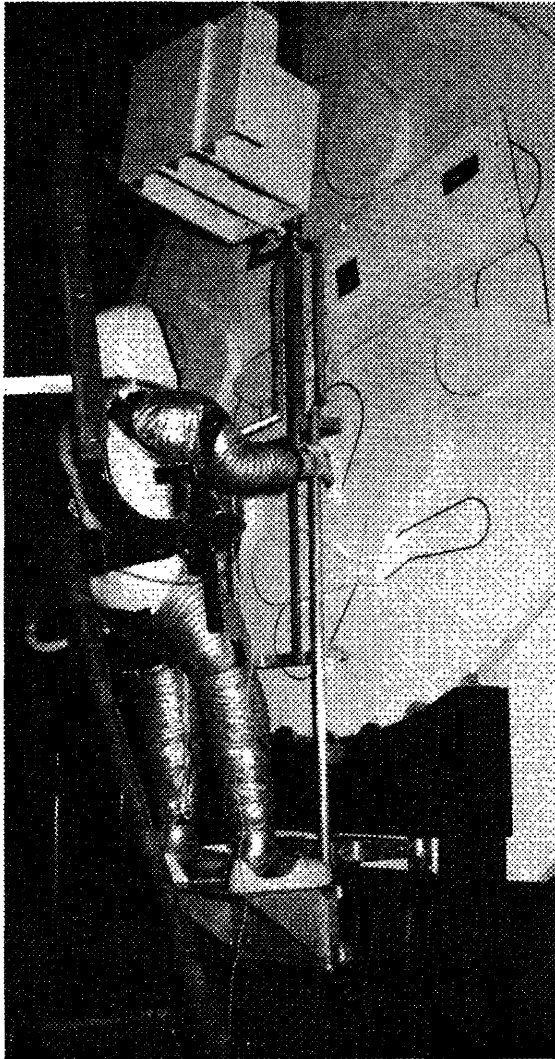

Figure 25. Modified Dual Rail Workstation Test Configuration



Figure 26. Sun End Film Retrieval With Canister Rotated 80° Clockwise

inserting his feet into the foot restraints because of poor visibility. The foot restraints were varied between toe-in and toe-out positions and with different spacing to alleviate the continuing foot disengagement problems. Mounting the foot restraints with a slight toe-in effect appeared to be the most desirable position. The 95 degree counterclockwise canister roll angle proved most effective, as both the S082A and S082B film magazines were accessible without swinging the workstation to the side (Figure 27).

The basic body position to canister access door relationship did not deviate significantly throughout the development of a sun-end workstation. Although the sliding platform concept seemed feasible on the

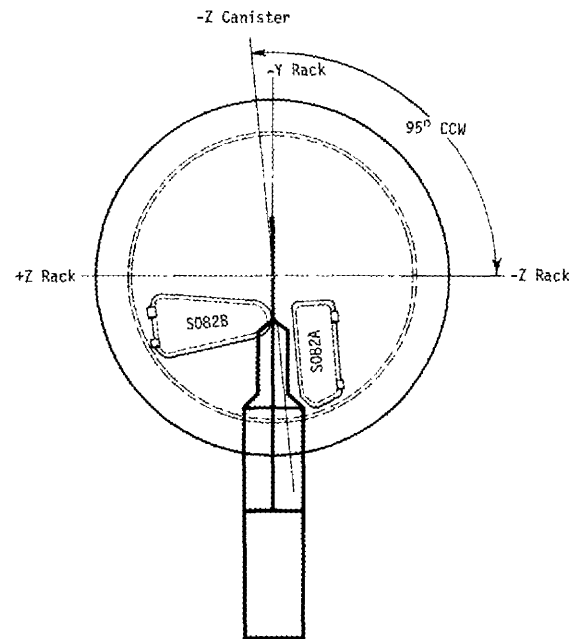
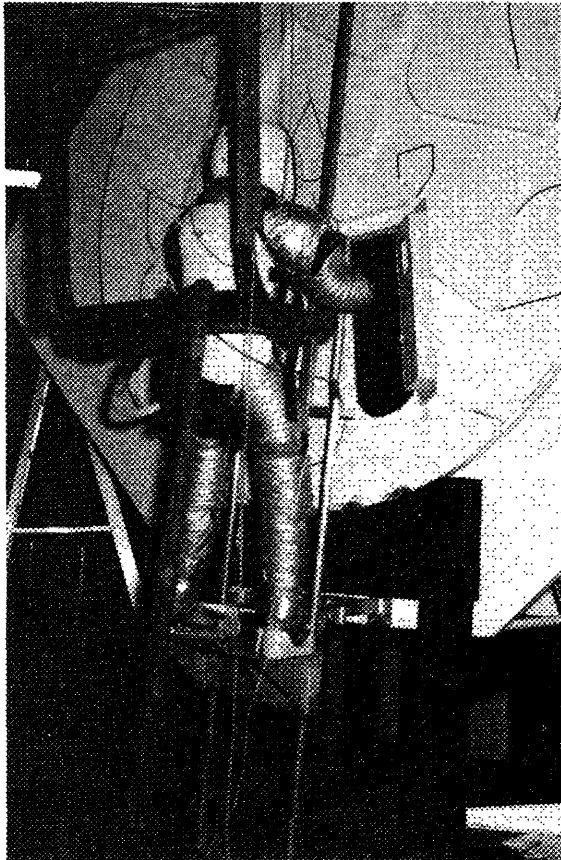

Figure 27. Dual-Rail Platform With Canister Rotated 95° Counterclockwise

basis of the developmental simulation tests, the problems involved in mounting hardware outside of the solar shield for erecting the workstation had not been resolved. Also, it had become apparent that with the canister rotated to the 95 or 112 degree counterclockwise position, translation across the sun-end was no longer required. With this knowledge, the integrated translation rail concepts were reconsidered and by cutting away a portion of the solar shield, adequate clearance for a workstation device combined with the translation rail could be achieved (Figure 28).

On July 19, 1968, a LM/ATM EVA working group meeting was held to review the EVA design criteria, EVA concept trade studies, and egress and ingress considerations. Agreement was reached that changing the primary EVA egress location from the AM hatch to the LM forward hatch would provide the highest probability for EVA mission success consistent with crew safety. Further studies were recommended to determine the optimum locations for the ATM workstations to shorten the EVA translation routes. A proposed sun-end workstation concept, utilizing the advantages of increased canister roll limits, was also presented at the meeting. The device would consist of a two-rail manual translation

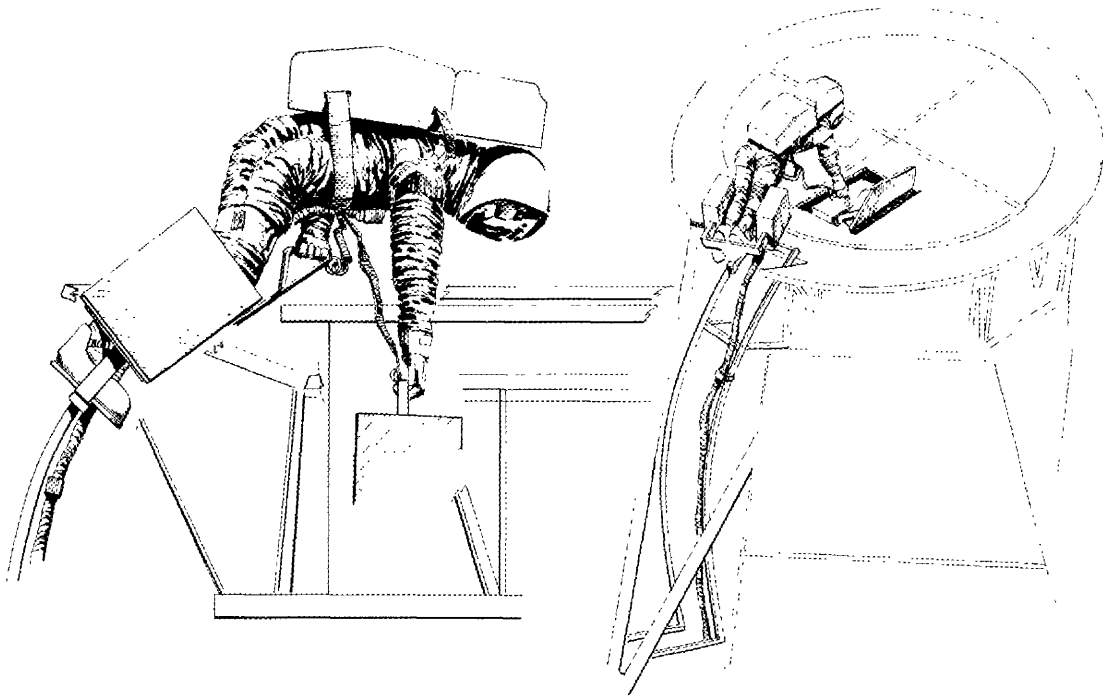

Figure 28. Solar Shield Opening for Combined Translation Rail and Sun-End Workstation Concept

method, leading to the solar shield, with stability augmented by tethers. A rotating section in the solar shield would serve as part of the workstation (Figure 29). The working group agreed that the concept was worthy of further consideration and development was begun in light of the imminent changes required upon approval of the EVA egress relocation.

D. Transfer and Translation Concepts

A major problem in developing the EVA system involved determining how to get the crewman and his cargo to and from the workstations unharmed, without damage to the vehicle exterior, without physically taxing the crewman, and without exceeding the specified EVA time constraints. Preliminary studies were conducted during the early part of 1967 to examine the requirements for equipment to support the EVA tasks. The early wet workshop cluster configuration required suited EVA and IVA throughout the cluster during activation and reactivation. All surfaces were relatively cluttered and presented snag and entanglement hazards for the EVA crewman. The requirement that EVA be conducted from the AM hatch for ATM film retrieval (Figure 30) seemed to compound the problems, and various combinations of umbilical lengths and connection points were analyzed during one-g walk-through simulations. The use of water and gaseous suit cooling loops were considered. An

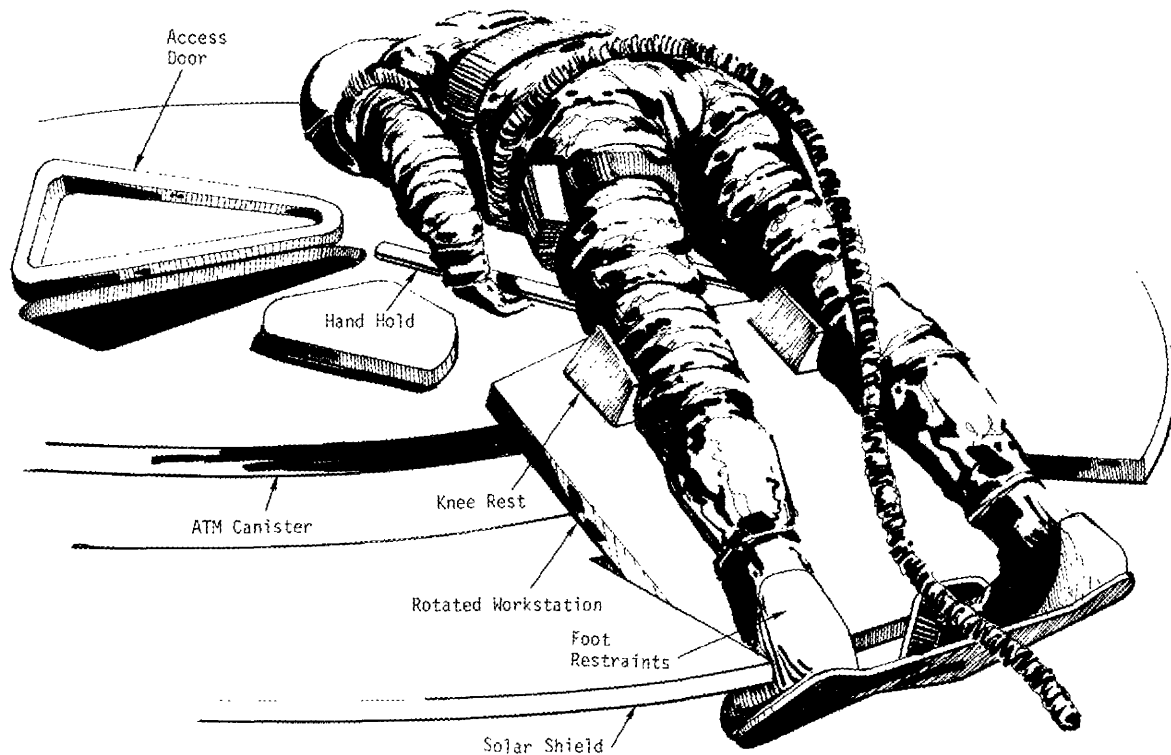

Figure 29. Concept for Sun-End Workstation On Rotating Solar Shield Section

umbilical length of 60 feet with provisions for cooling water and a mechanical tether was selected. Handling and managing the long umbilicals to prevent damage, extended translation over irregular surfaces, and equipment handling posed combined problems for the EVA crewman and indicated that a secure mobility aid system was required. The possibilities for umbilical entanglement created considerable concern because of the lack of experience with long umbilicals.

Evaluation of previous Gemini experience and early AAP workshop equipment transfer studies suggested that the basic mobility aid should be a handrail. A single rail would suffice in most cases, but dual, parallel rails would be preferred for hazardous or frequently traveled routes. The handrail developed for earlier space walks had a rectangular cross-section approximately 1 1/4 inches by 1/2 inch. These findings resulted in the development of concepts to combine mobility aid handrails with these basic dimensions, with crew and umbilical tethers and equipment transfer devices. The major problem encountered in development of a handrail system was the discontinuity required in the rails because of the assembly of the cluster modules on orbit.

In order to shorten the astronaut translation and film transfer distances to and from the AM hatch, it was recommended, during the summer

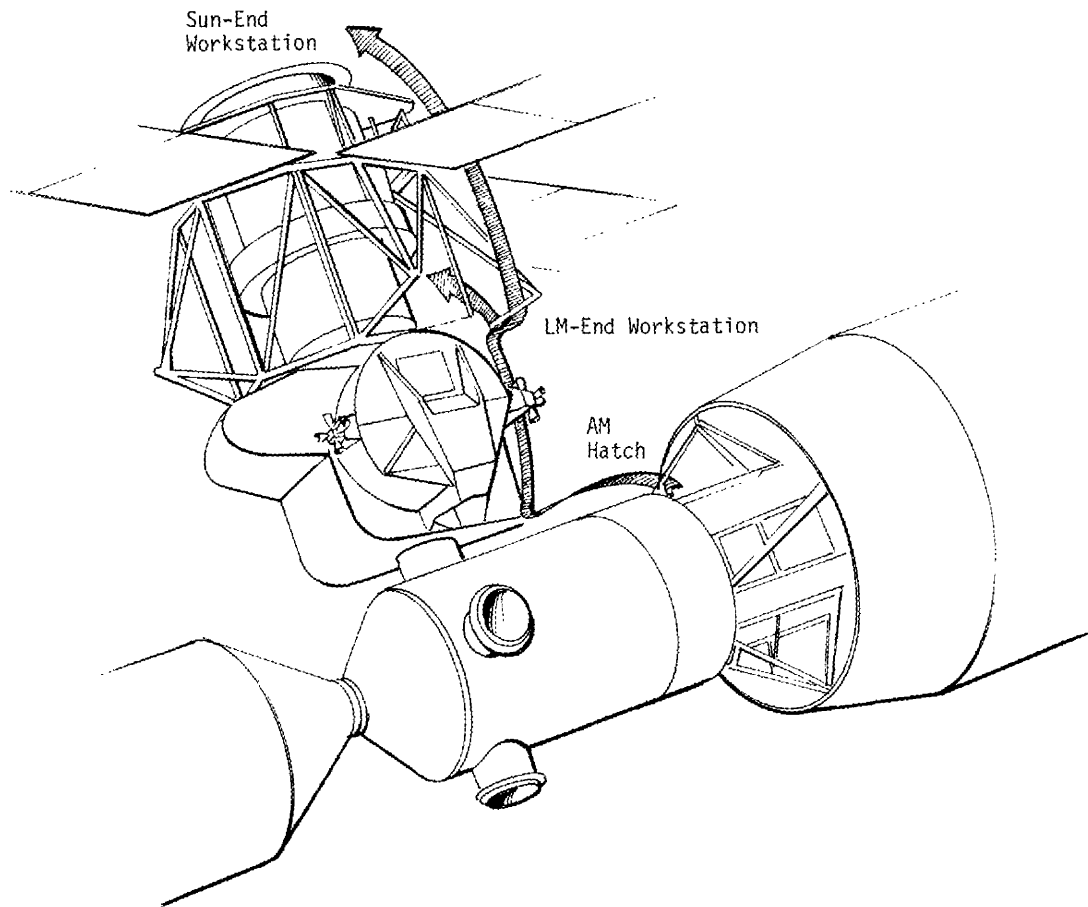

Figure 30. ATM Film Retrieval EVA Routes

of 1967, that film retrieval be conducted from the LM forward hatch rather than the AM hatch. Since the LM contained the ATM experiment controls and had its own independent power source, egress from the LM forward hatch provided additional advantages, particularly with the free-flying, decoupled LM/ATM backup mission still under consideration. The film magazines could be stowed in the LM cabin instead of inside the AM, which would reduce the distance required for transfer and the risk of damage. In anticipation of approval for this change the emphasis on ATM film retrieval EVA studies centered around crew translation and transfer of film magazines in the vicinity of the LM/ATM and between the two workstations.

During this period, however, there was much concern for the total workload to which the crew would be subjected, primarily because of the Gemini EVA experience. Many concepts for crew translation and film magazine transfer were investigated and simulated using the existing workstation concepts. While the most promising concepts being analyzed were rail systems consisting of handrails affixed to the MDA and LM/ATM exterior with umbilical guides and foot restraints, a few designs considered telescoping or extendible booms of various types. Because of

the preoccupation with crew workload, some of the early concepts were highly automated.

One of the earliest automated devices considered was a serpentine actuator or "serpentuator". This device consisted of a series of connected, individually controlled and powered, articulated links with a roll ring base and a payload-control station at its tip (Figure 31).

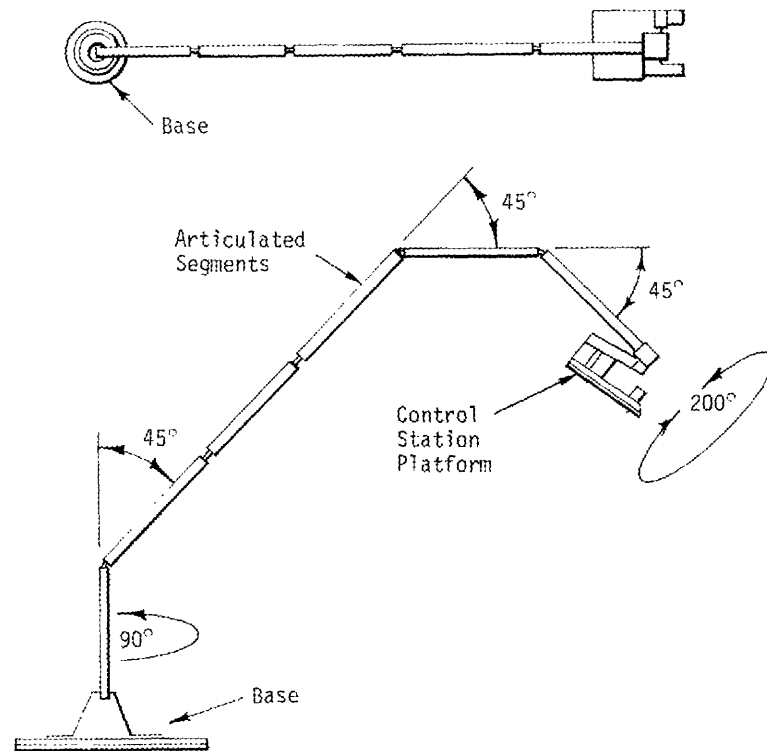

Figure 31. Serpentuator Concept

The serpentuator would pick up the astronaut and seven film magazines at the egress hatch and deliver them to the ATM workstations. Investigations to determine the forces which could be generated by serpentuators of various lengths, diameters and number of segments showed that its payload capability was adequate for the translation task. Studies of the concept were continued to evaluate geometric capabilities, safety aspects and control requirements. Figure 32 shows the serpentuator concept during evaluation with scale models of the cluster to determine reach envelopes. These early studies showed that the serpentuator concept was a feasible transfer and translation device and provided justification for continuing the investigations. Design requirements were identified to provide guidelines for further development. The problems associated with umbilical management during translation on the serpentuator were recognized and several techniques were studied to control the umbilicals. Figure 33 illustrates one of the methods considered along with a concept for the cargo rack and control station platform. Although quite heavy

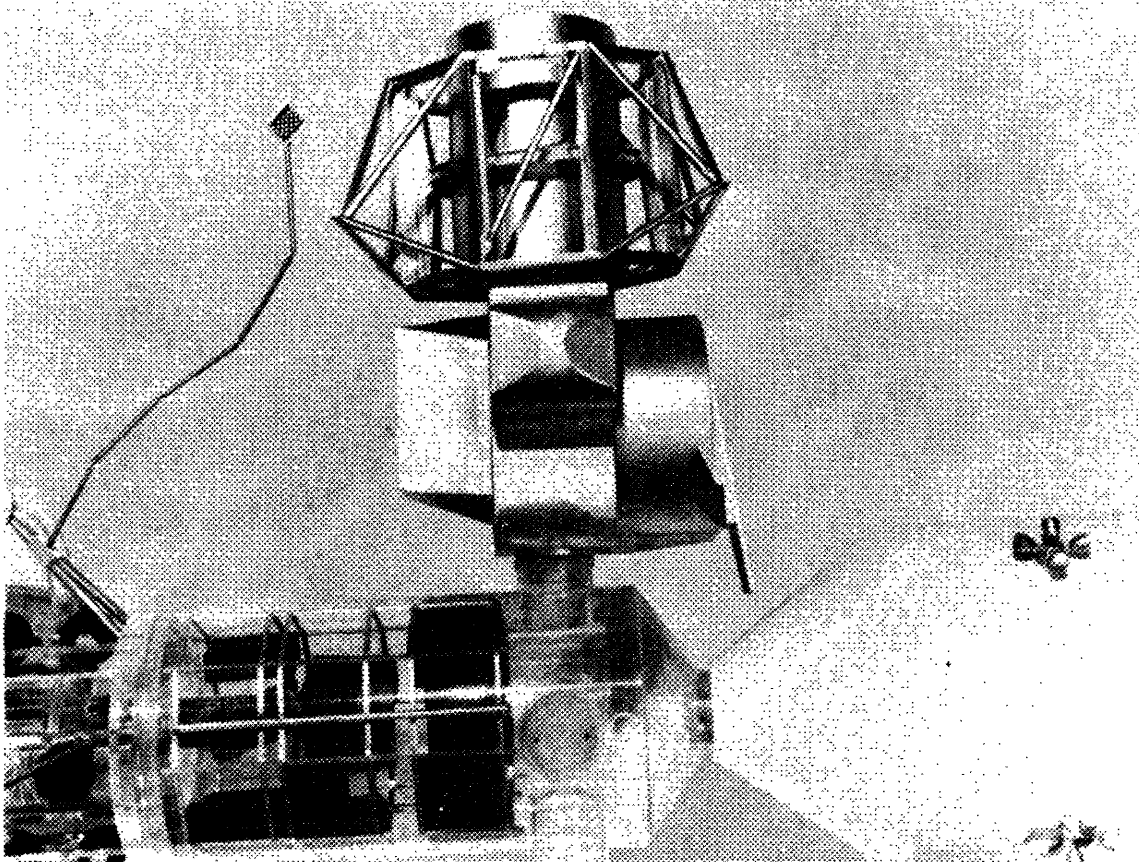

Figure 32. Serpentuator Concept Evaluation Model

and complex, the serpentuator offered considerable savings in crew workload and was, therefore, given initial emphasis over other boom concepts.

"Roll-up" booms, which formerly had been used as antennas and gravity-gradient stabilization devices on unmanned satellites, were also considered for crew translation aids and cargo transfer. Figure 34 shows the deployed configuration of this concept. The boom tip would engage a funnel shaped receptacle at the workstations and provide a continuous rail for hand-over-hand crew translation. Two types of roll-up booms were investigated. The Bi-Storable, Tubular Extendible Member (STEM) system provided a direct path between the AM hatch and the sun end or LM-end workstations. In the stowed position the STEM boom consisted of two flat metal strips wound simultaneously on a single reel (Figure 35). During the deployment the strips formed two columns, one inside the other, and extended in a straight line into the receptacle. The STEM, as it was extended or retracted, would transfer the film.

The Application Technology Satellite (ATS) boom system was similar and deployed in the same manner as the STEM. The ATS boom consisted of a

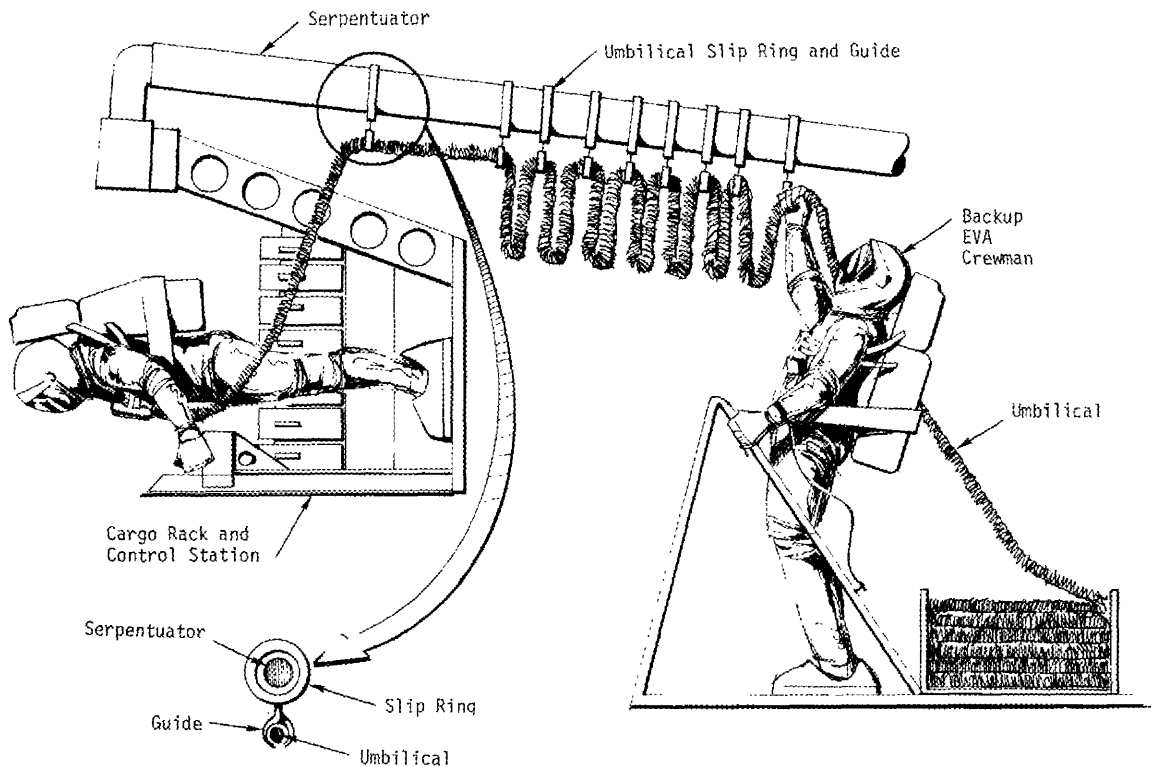

Figure 33. Serpentuator Umbilical Management and Cargo Carrier Concept

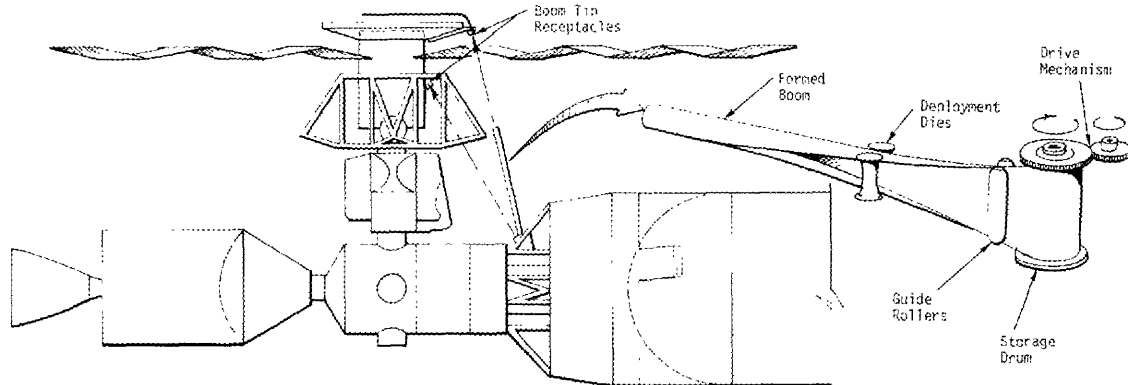

Figure 34. Roll-Up Extendible-Boom Deployment Concept

flat metal strip stowed on a reel (Figure 36). As the strip unrolled, it curled into a tubular shape with an interlocking, rigid seam.

Another mobile boom system, called the Astro Mast or lattice boom, was also investigated as a means of delivering the crewman to both workstations or the LM hatch. It would be mounted on the AM and was made up of a foldable truss structure (Figure 37) stowed in a canister. The

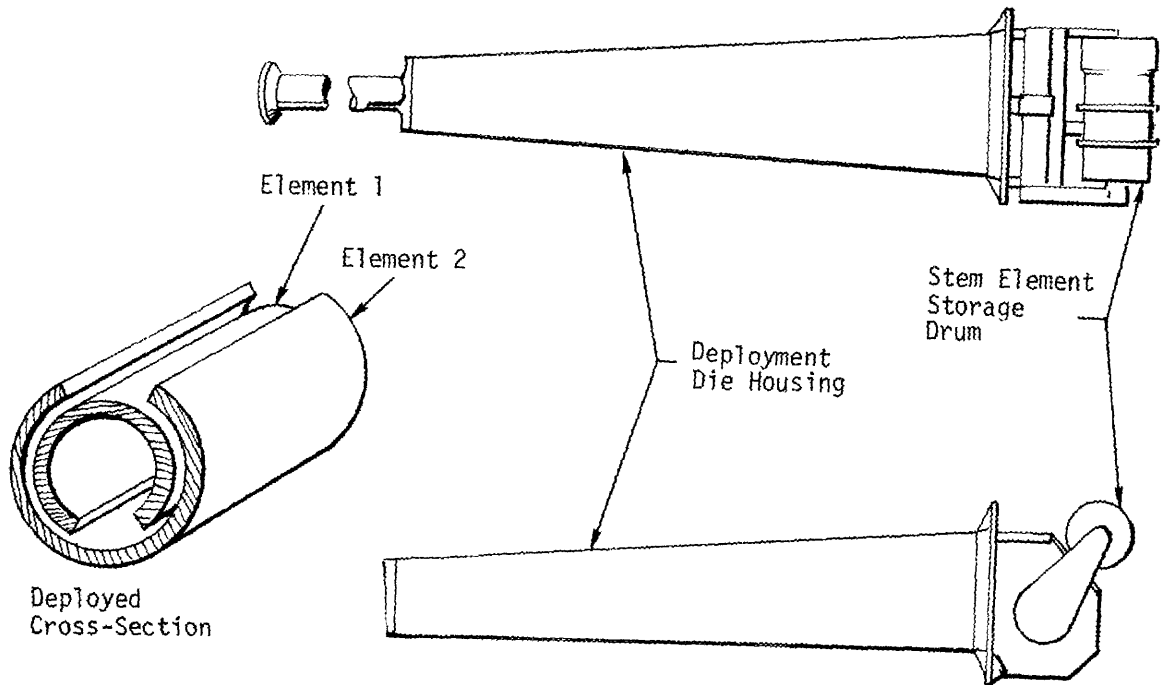

Figure 35. Bi-Storable, Tubular Extendible Member (STEM) Device

bottom element of the boom was rotated, while the upper elements were restricted from rotating during extension of the column. This action forced the truss members to unfold and lock in place. The canister base could be rolled and pivoted to direct the free end of the boom to the desired location. One longeron in each structural section could be constructed shorter than the other two to produce an arc or bend in the column thereby enabling the free end to reach points not attainable by line-of-sight translation.

The boom concepts remained under consideration as a method of cargo transfer and as a crew translation aid throughout the early development period. Manual translation by the crewman using fixed hand-rails was ultimately selected as a primary system because of the complexity of the boom devices, the lack of sufficient bending stiffness, and the potential hazards related to the metal tapes forming the roll-up boom elements. The simpler booms, however, continued to be studied for film magazine transfer. The serpentuator was rejected as a crew and cargo transfer device because of its considerable weight and complexity and the requirement that any mechanically augmented translation device have a manual backup capability.

Toward the end of 1967, the most promising manual translation concept for moving between the sun end and LM-end workstations appeared to be a single rectangular translation rail (0.55 inch by 1.25 inches) with

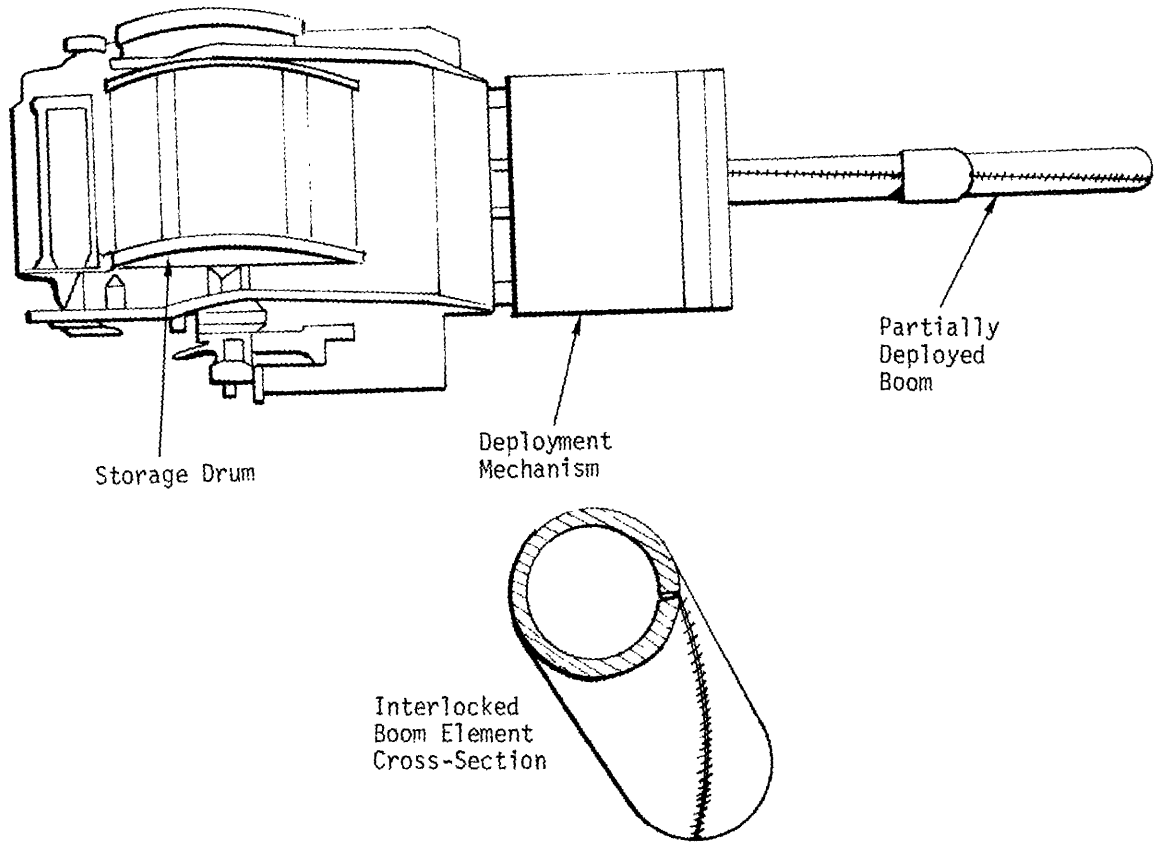

Figure 36. Application Technology Satellite (ATS) Boom Deployer

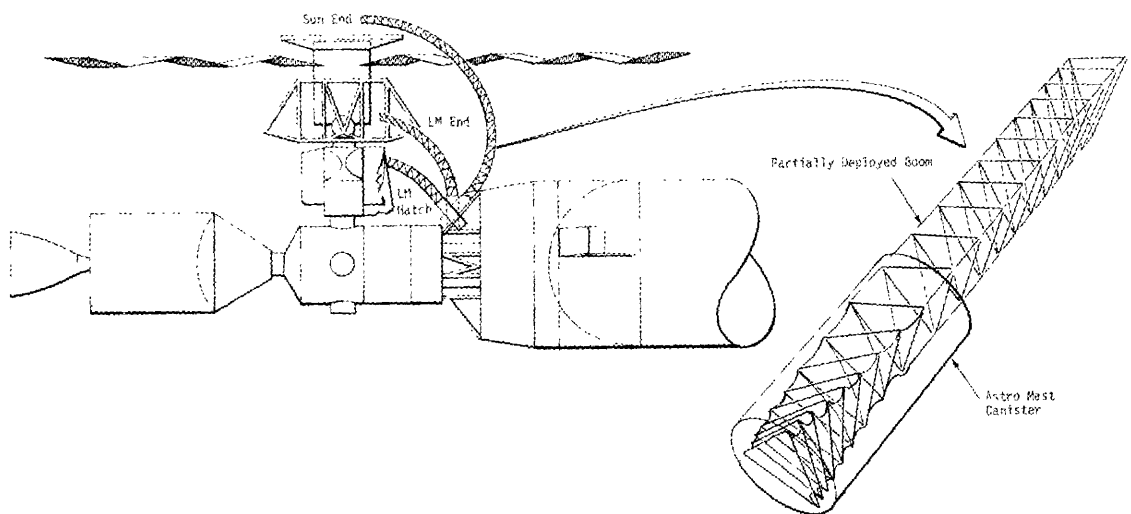

Figure 37. Astro Mast Lattice Boom Deployment Concept

sliding Gemini-type foot restraints and a separate umbilical clip rail (Figure 38), attached to the rack structure at the ATM +Y axis. Design development simulations, both in one g and with the six degree-of-freedom simulator, had proven the feasibility of the basic concept and a neutral buoyancy mockup was prepared for further evaluation.

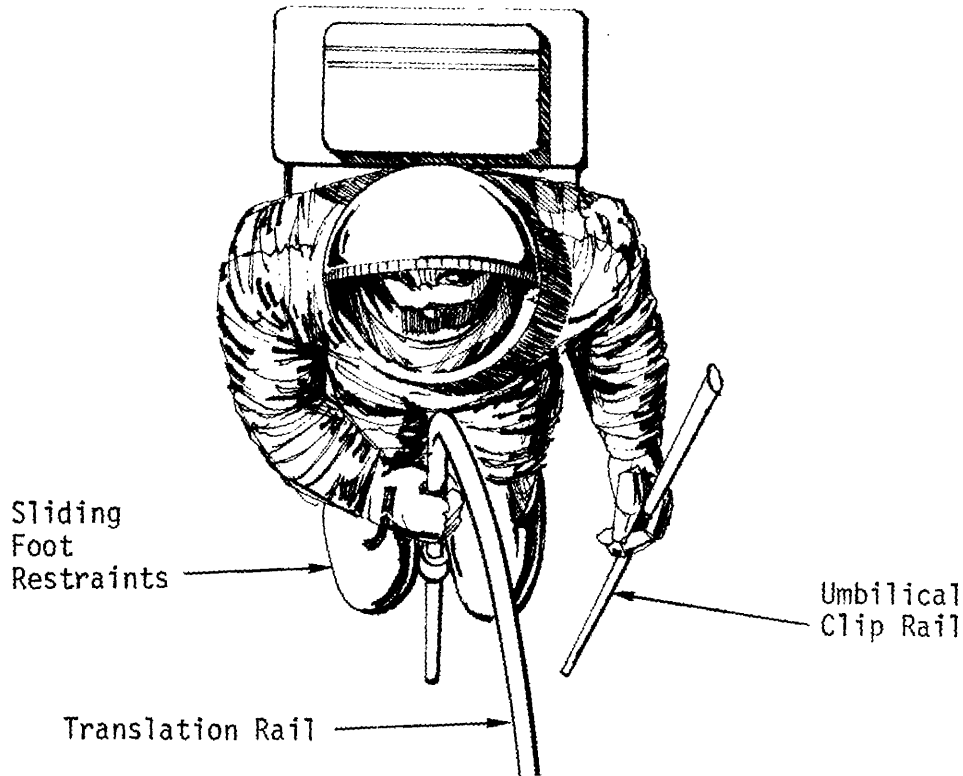

Figure 38. Single Rail Manual Translation Concept

The neutral buoyancy test, performed in December 1967, evaluated the translation task both with and without foot restraints. Examination of the test results revealed the following information:

1. Translation with foot restraints was possible and provided excellent security for the crewman, however, binding of the foot restraints on the rail significantly increased the crewman's workload.
2. The proposed single translation rail concept was inadequate. The umbilical clip rail was used as a translation rail, therefore, a two-rail system appeared more practical.
3. The proposed umbilical clip was not usable because of a reach and balance problem. Since the umbilical must be restrained during translation to prevent entanglement, the restraint system should be located directly in front of the crewman and clipped between the translation rails.

The knowledge gained from these early simulations, while performed with low-fidelity mockups, revealed that the concept of manual translation using handrails was feasible and worthy of further development. It also became apparent that there were many advantages to integrating the sun end workstation with the translation device located between the workstations. In early 1968, consideration was given to film transfer by means of a sliding platform, which held the film magazines, attached to a single continuous translation rail running from the ATM hatch to the LM/ATM (Figure 39). The experience with sliding foot restraints and the problem of erecting the rail system, however, led to de-emphasis of such devices in favor of simpler means of translation. Although the idea of a continuous rail was subsequently dropped, some of the features of the system found their way into design concepts for the combined sun end workstation and translation device (Figure 29).

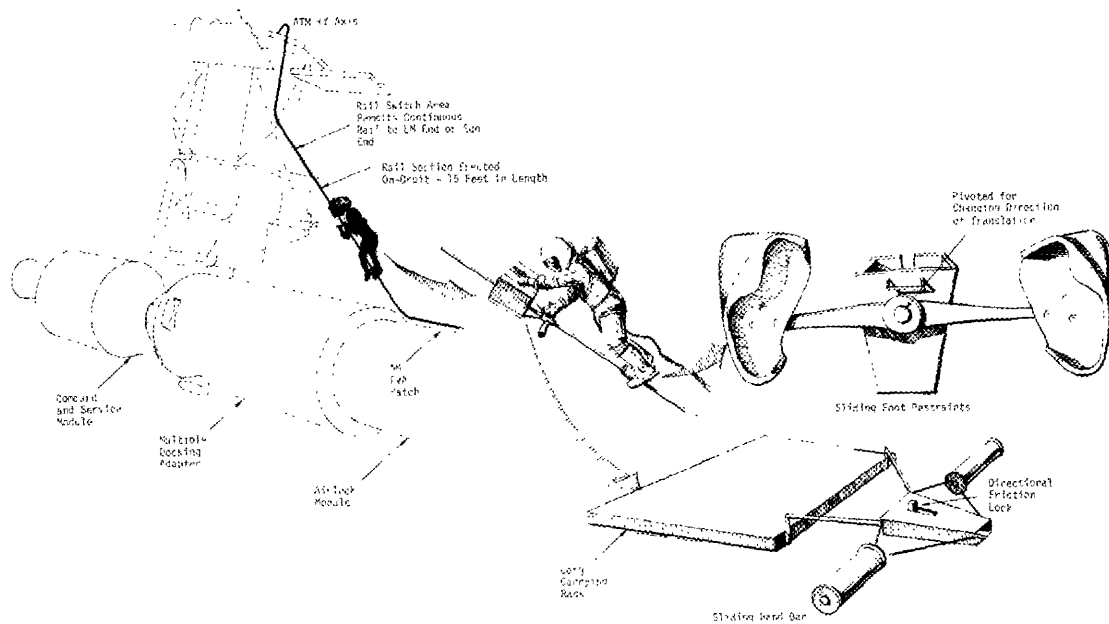

Figure 39. Continuous Rail Translation System

As development progressed and understanding of man's ability to conduct orbital EVA increased, the complexity of the translation and transfer concepts decreased. The use of handrails for crew translation between the AM hatch and the LM/ATM workstations became the primary or baseline mode and work centered around refining the proposed routes across the cluster surfaces. Figure 40 shows the handrail locations for access to the MDA docking ports and the LM/ATM as envisioned before the EVA egress changed to the LM hatch. Development of concepts for cargo transfer, however, were still continuing with emphasis on mechanical assistance devices to supplement the manual transfer of film magazines.

The application of smaller STEM booms and telescoping rails were proposed as a means of film magazine transfer.

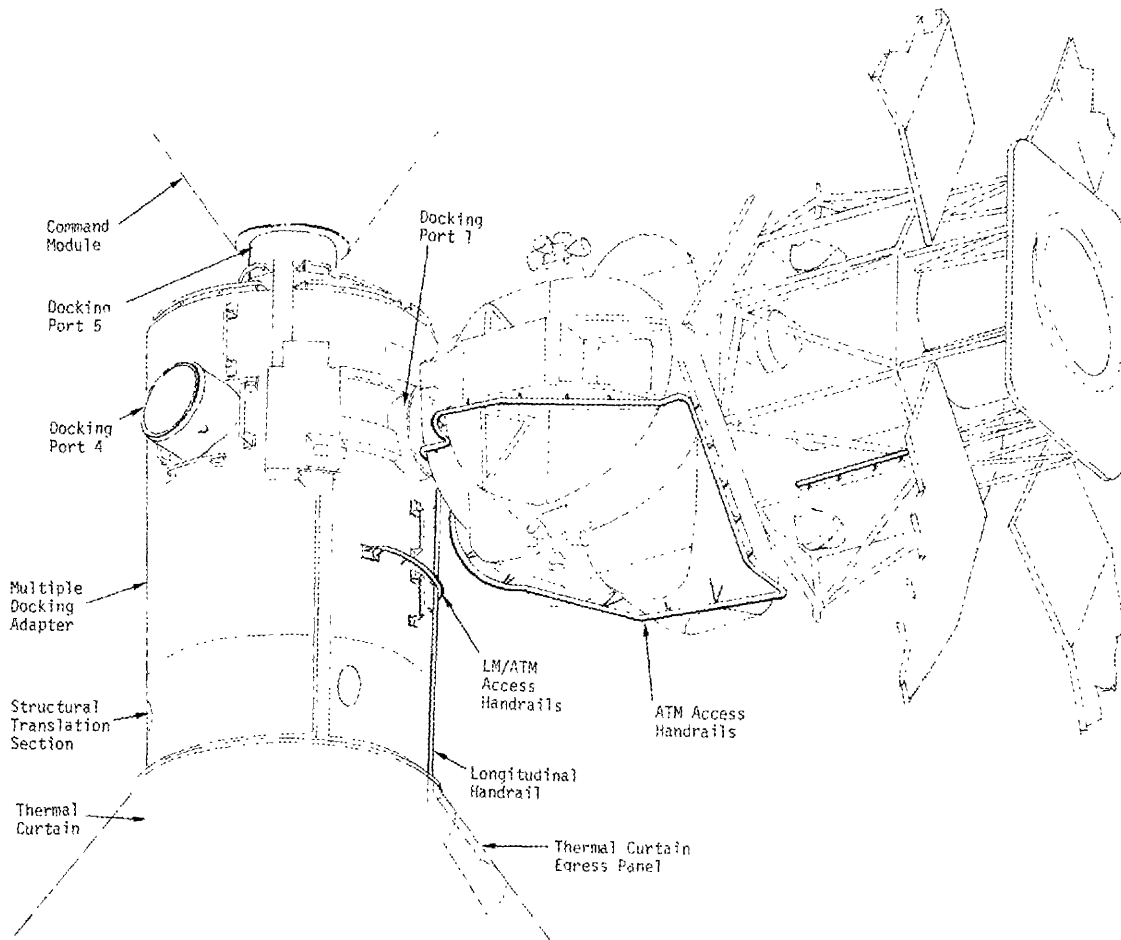

Figure 40. Cluster EVA Translation Handrail Locations

Concurrently with the concept definition activities for translation and transfer methods, studies were being performed that identified the operational advantages of changing the EVA egress and ingress point from the AM hatch to the LM forward hatch. These studies determined the following advantages for using the LM hatch:

1. Manual translation task minimized.
2. Cargo handling and transfer minimized.
3. Exposure time minimized for both cargo and crew.
4. Design of cargo translation device simplified.

5. Umbilical handling and control simplified.

6. Minimum length of umbilical required.

During the summer of 1968, it was recommended that this change be adopted as a new baseline by the intercenter EVA working group.

SECTION IV. FINAL WET WORKSHOP CONCEPT - EVA EGRESS FROM LM

The change to EVA egress from the LM forward hatch shortened the translation distance to the ATM workstations, but required re-evaluation of the workstations and their relationship to crew translation methods and film magazine stowage and transfer techniques. The locations of the workstations with respect to the LM hatch still involved considerable translation distance around the complex ATM rack structure and through the solar arrays. Although the LM-end workstation had reached an advanced stage of development, the sun-end workstation was still in a conceptual phase, and the entire EVA film retrieval task required re-examination to provide an integrated system.

This section of the report describes the EVA system development from the change over to egress from the LM hatch in mid-1968 to the finalization of the wet workshop system in mid-1969. Design studies continued during this period with the various one-g mockups and multiple degree-of-freedom simulators. However, zero-g simulation techniques, using the neutral buoyancy facility at MSFC and KC-135 aircraft, began to play an increasing role in the development of promising design concepts. Final verification of the candidate concepts was normally performed in neutral buoyancy simulations, while the KC-135 flights were used to verify special aspects of the equipment. The aircraft technique provided approximately 30 seconds of zero g during each parabolic flight maneuver and involved those tests where zero g or dynamic response were the most important considerations. Such tests included: umbilical stowage evaluation, package transfer and mass handling studies and film magazine operations.

A. Cluster Configuration

The final wet workshop mission still required four Saturn IB launch vehicles. Unmanned rendezvous and remote docking of the LM/ATM had been developed, however, and no longer required a crewman on board. The number of docking ports on the MDA was reduced to a single axial port and two radial ports - one for the LM/ATM and one spare port for a CSM. The solar array systems were refined, and the SLA panels would be jettisoned during launch. The final wet workshop orbital configuration is shown in Figure 41.

The lunar module ascent stage was modified to accommodate film magazine and umbilical stowage for the film retrieval operations and re-designated the "LM-A". The plans for an alternate mission with the LM/ATM docked with the CSM were continued to provide a contingency mission in the event of problems with the workshop mission.

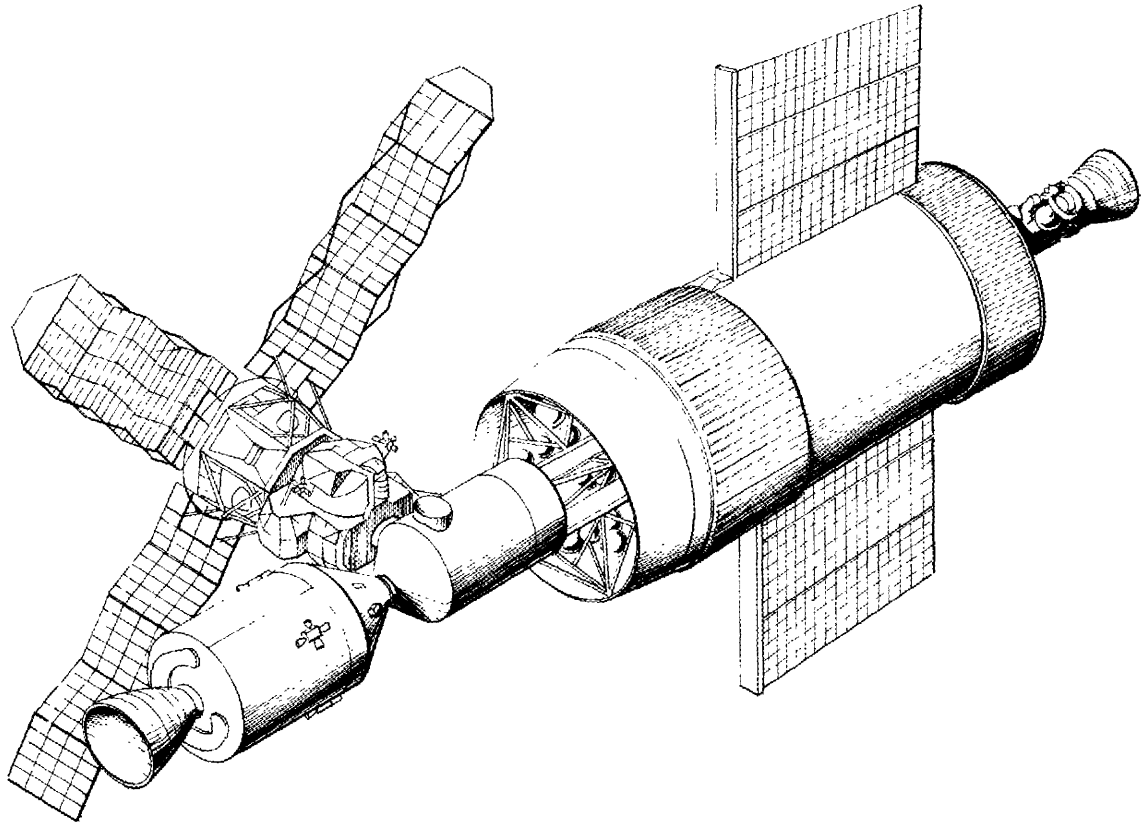

Figure 41. Final Wet Workshop Orbital Configuration

B. EVA Requirements and Guidelines

The continuing design development of vehicle systems, ATM experiment instruments, and astronaut life support systems, combined with a better understanding of man's EVA capabilities, served to eliminate some constraints on EVA system design and to clarify some of the more limiting requirements. One of the most significant changes was the conversion of the S083 experiment from a film camera to a video data retrieval system. This modification left four film magazines requiring removal and replacement from the LM end. Design evolution of the portable life support systems as a backup mode to umbilical EVA resulted in the Portable Environmental Control System (PECS) as a proposed replacement for the lunar PLSS. The PLSS was rejected because it could only be used one time and had to be recharged on the ground. The cost of developing the PECS promoted consideration of performing EVA with life support umbilicals alone. The use of the PECS, however, remained under evaluation as the life support studies continued and required that clearance envelopes for the suited crewmen consider the possibility of using the backpack.

The following requirements and guidelines reflect change to the listing in the preceding section as applicable to this period in the EVA system development:

1. Mission

a. The maximum time for EVA would be three hours, exclusive of preparation and post EVA requirements.

b. Equipment would be designed to allow performance of EVA during both daylight and dark periods of orbit.

2. Film Cassettes and Stowage. A maximum of six film magazine/cassettes required EVA for retrieval and replacement. S052, S054, S056, and H-Alpha 1 magazines would be replaced at the LM end of the canister. S082A and S082B magazines would be replaced at the sun end.

3. Cluster Egress and Ingress. EVA egress and ingress would be accomplished from the LM forward hatch.

4. Life Support System

a. The A7L pressure suit, Emergency Oxygen Pack (EOP), PCU and life support umbilical would be used during EVA.

b. The sizing of translation aids, translation paths and workstations would not preclude the use of the PECS.

5. Safety

a. Direct line of sight between crewmen would not be required at all times.

b. EVA translation would preclude the crewman from impairing operation or causing damage to ATM components and experiment instruments (deleted April 1969).

c. EVA translation would preclude the crewman from impairing operation or causing damage to the pressure suit and life support equipment, including umbilicals, as well as the ATM components, including experiment instruments and solar arrays (added April 1969).

d. Crew restraint systems would incorporate redundant methods of release. Release mechanisms would be the quick-action type and designed for one-hand, EVA operation with gloves.

e. Umbilical management would be performed by the backup crewman. This did not exclude the possible requirement for tethering the umbilical to the handrails.

f. Power to the ATM canister during EVA would be limited to gimbal roll control, sun-end aperture door activation and lighting.

C. Workstations and Canister Access

One possible solution to further reducing the translation distances between the egress hatch and the ATM workstations was presented for consideration at the July 19, 1968, LM/ATM EVA working group meeting. It was proposed that the LM-end workstation be moved to a position only 45 degrees from the LM hatch and the sun-end workstation be located directly underneath the hatch (Figure 42). While the working group studies the impact of relocating the workstation, development proceeded to refine the existing concepts and establish design guidelines for EVA operations at the LM hatch.

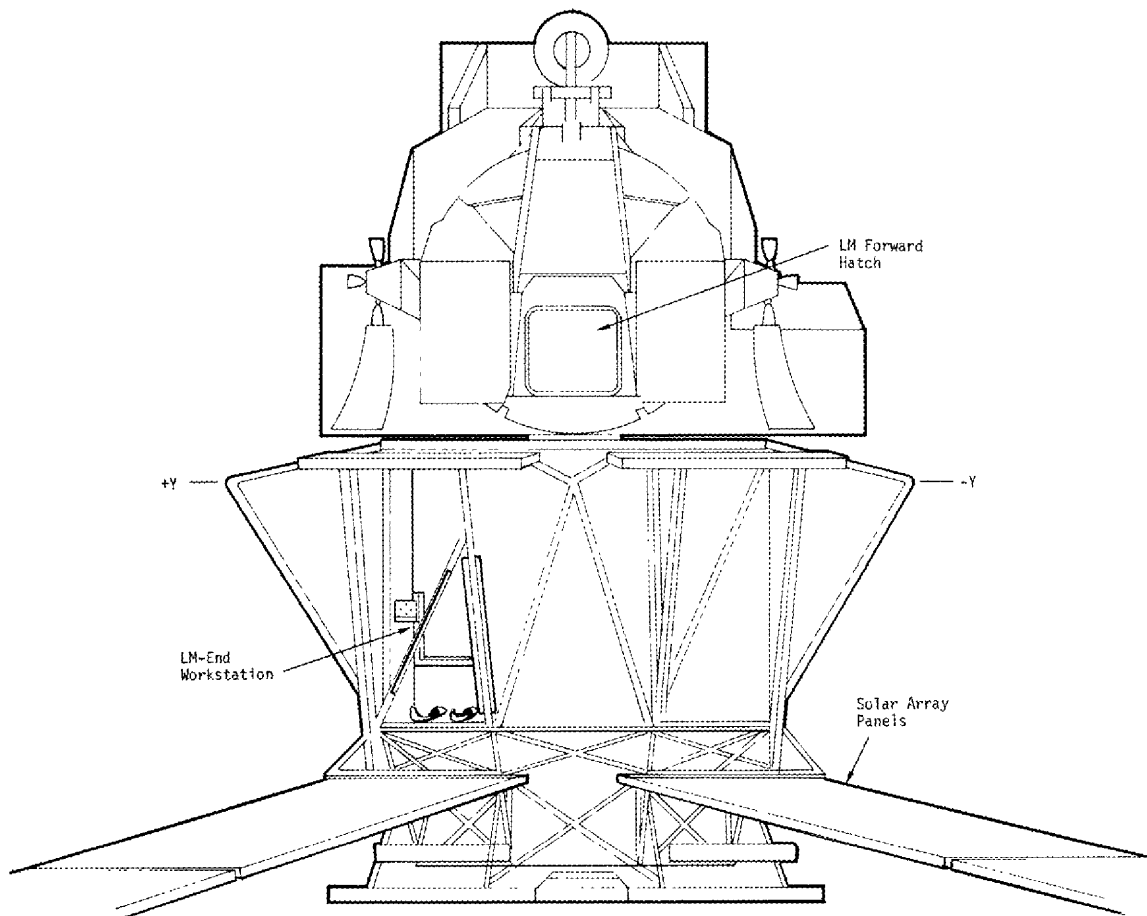

Figure 42. Proposed Workstation Relocation Concept

1. LM Hatch Workstation - During the fall of 1968, the AAP Program Office approved the change for EVA egress from the LM hatch. This necessitated the development of a new workstation just outside of the LM hatch, to facilitate the handling and transfer of film magazines through the hatch. The LM hatch workstation would require provisions for body restraints compatible with hatch accessibility and the film transfer and crew translation devices being developed.

As a result of preliminary studies, four possible workstation locations were identified and entitled "workstations A, B, C and D". Workstations A, B and C incorporated the Gemini-type foot restraints mounted in different positions on the ATM outrigger truss and on the LM forward cabin above the hatch. Workstation D consisted of the proposed manual rail translator device or "trolley" located in its launch stowage position near the LM hatch. A one-g evaluation was performed using the multiple degree-of-freedom simulator to select the two best concepts for further study with respect to reach and vision envelopes and to identify possible locations for film transfer devices (Figure 43). The results indicated that workstation A demonstrated the most efficient crew utilization factors, while workstation D, located on the trolley translation device, was the most deficient because of vision and reach obstructions. A variety of alternate trolley locations along the rail were evaluated with no improvement in reach capability. It was concluded that the severe position limitations imposed by the operational envelope of the trolley system prohibited its use as an adequate workstation. Workstations B and C were found to be about equal, each having some advantages over the other. On the basis of objective data and subjective comments obtained during the test, workstations A and C were selected for further investigation.

Subsequent evaluations and trade-off studies of the two concepts were performed with various foot restraint positioning in conjunction with the candidate film magazine transfer and crew translation devices. Although workstation C demonstrated significant advantages in some respects, workstation A was ultimately chosen as the preferred concept because it provided the best solution to LM hatch egress, workstation ingress, and translation device access. The reach and visibility afforded by workstation A was also the more compatible with the film magazine handling requirements, both during transfer through the hatch and while loading the transfer devices. Upon completion of these preliminary evaluations, the designs were refined and hardware was fabricated for verification testing in neutral buoyancy.

The development of optimum hand hold and handrail locations at the workstation and integration with the film transfer devices continued into mid-1969. As this work progressed, definition studies were completed on the Saturn V-launched "dry workshop" and the decision was made, in July 1969, to redefine the AAP configuration. The new Saturn V workshop would eliminate the LM-A from the cluster and therefore removed the requirement for the LM hatch workstation.



Workstation A

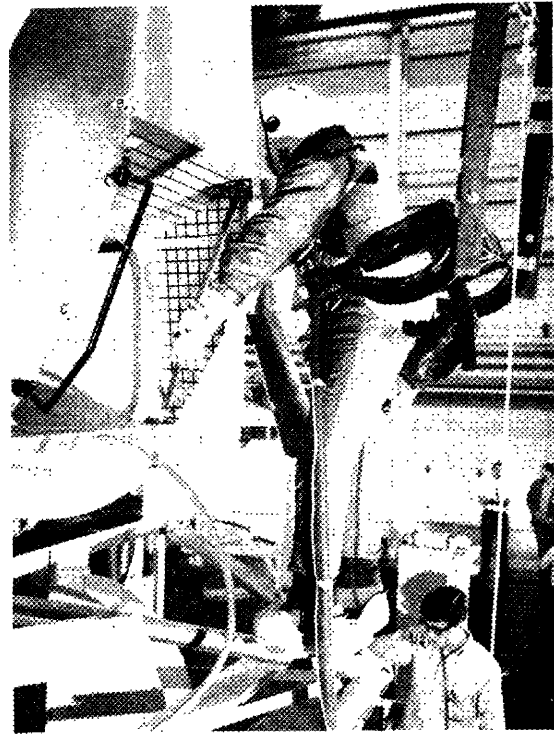

Workstation B

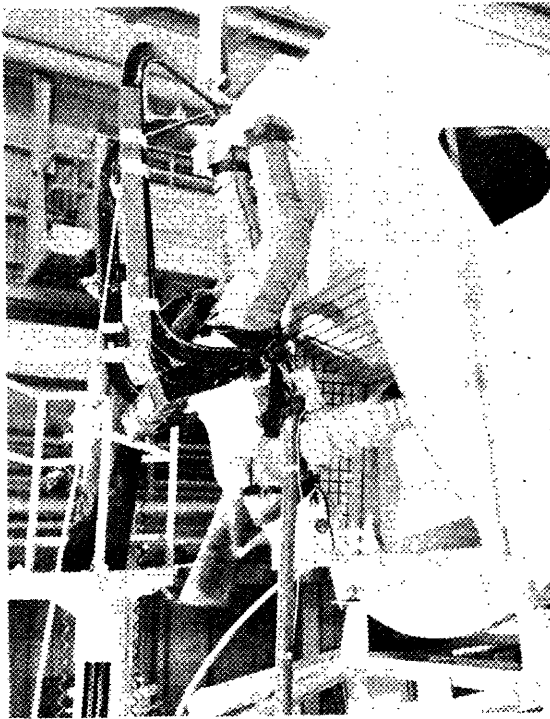

Workstation C

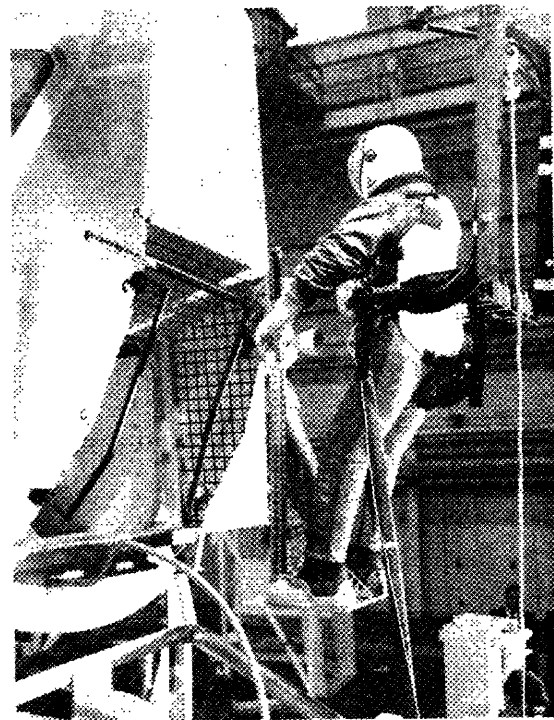

Workstation D

Figure 43. LM Hatch Workstation Concepts

2. LM-End Workstation. The relocation of the LM-end workstation to the ATM quadrant nearest the LM hatch was accomplished with little effect on the workstation itself. The primary changes involved redefinition of the canister roll angle requirements and gimbal lock positions. The design effort concentrated on developing the workstation to achieve compatibility with the translation and film transfer concepts. During an astronaut evaluation of the workstation in March 1969, the canister roll control panel and gimbal lock controls at the LM-end workstation were located in an acceptable position, but there was concern over a crewman's ability to properly align the canister with pushbutton controls in order to engage the gimbal lock. The roll controls had to align the canister to within ± 0.1 inches at five canister positions with minimum crewman effort and error possibility. Since the gimbal lock system design had already been established, and hardware was being fabricated, a new integrated roll control panel was conceived to satisfy the alignment requirements (Figure 44). An optical target reference was developed to aid in positioning the canister for gimbal lock engagement. Further studies left some doubt as to the mechanical lock pin capabilities because of tolerance buildup at the roll ring hole, and investigations began to assess alternate methods of fulfilling the locking requirements.

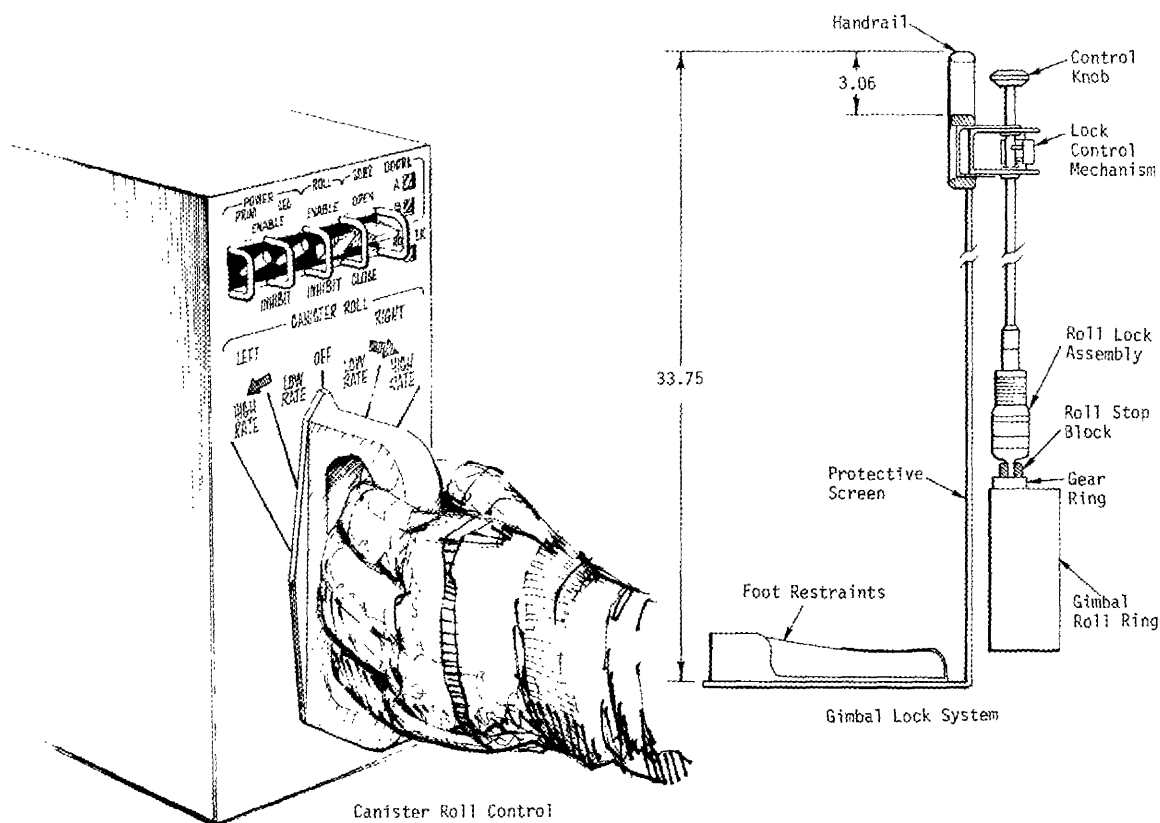

Figure 44. Canister Roll Control Panel and Gimbal Lock System

While refinements to the workstation continued in preparation for an astronaut crew station review, the decision was made to convert to the dry workshop. Since the principal EVA requirements for film retrieval were to remain the same, the objective for EVA system development became maximum use of existing hardware with minimum modification for the dry workshop.

The crew station review was held during August 1969, and primarily involved those elements of the EVA system which were applicable to the dry workshop. Figure 45 shows the LM-end workstation mockup configuration for the one-g phase of the review. The most significant difficulty encountered with the LM-end workstation was the canister rotation and locking system. While the handle-type control was preferred over the push-button method, the crewmen felt that an automatic indexing system to provide automatic "stop and lock" capability at each film access door would markedly reduce the workload at the workstation and eliminate the need for an optical alignment system with dependence upon astronaut visual ability. The suggestion was discussed, but it was decided that implementation would be difficult and would cause a serious impact on the existing hardware design. Deletion of the manual gimbal locking mechanism, however, was under evaluation at the time of the review. The feasibility of using the electrical canister roll brake, which was actuated by the "Roll-Inhibit" switch on the rotation control panel to provide a positive canister lock, had already been demonstrated. Because analysis of the complex circuitry that prevented inadvertent canister rotation during film retrieval had not been completed, the manual lock was retained. Film magazine handling presented problems and the restraint provisions were considered adequate.

3. Sun-End Workstation. At the July 1968 working group meeting a new sun-end workstation concept was presented and recommended for further development. The concept, as proposed, incorporated the Gemini-type foot restraints arranged to slide on the translation rails (Figure 29), with the rotating section of the solar shield providing the workstation restraints. During development of the concept, it was decided to eliminate the sliding foot restraints because of the binding problems experienced in previous tests. Also, the Gemini-type foot restraints had to be individually sized to fit each crewman's boots. This prompted the design of a more universal method of restraining the crewman's feet. The basic idea of combining the solar shield and workstation components was retained, but the foot restraint design called for attachment to the solar shield section and consisted of two toe restraint bars and a "T" shaped heel restraint called the "goat's horn" (Figure 46). Knee rests and a folding handrail with tether rings completed the concept. The workstation hardware was fabricated for installation on the one-g ATM sun-end mockup so that the concept could be evaluated with a pressure suited crewman in the six degree-of-freedom simulator.

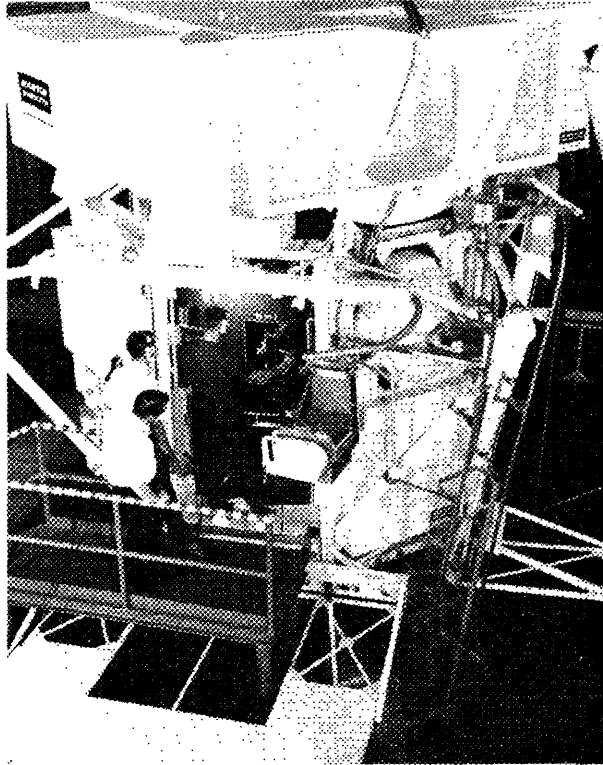

Figure 45. Final Wet Workshop LM-End Workstation Configuration

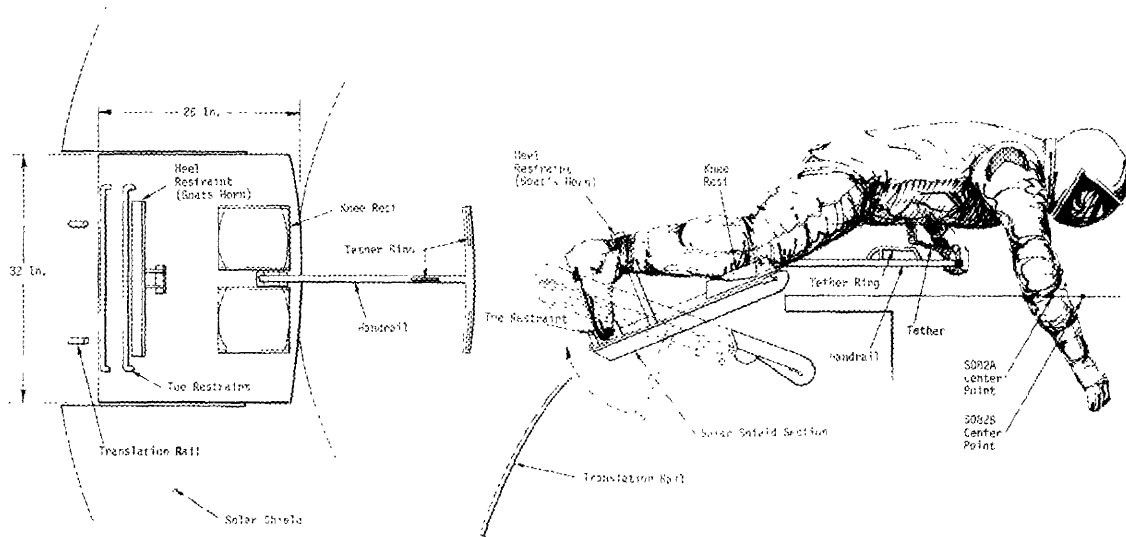

Figure 46. Sun-End Workstation Mounted on Rotating Solar Shield Section

During the simulation test, the subject encountered moderate difficulty in transferring from the parallel translation rails and across the workstation. The helmet interfered with the heel restraint, and the handholds were inadequate for workstation ingress (Figure 47). The crewman experienced extreme difficulty in attempting to enter the workstation foot restraints because of poor visibility, insufficient handholds, and the foot restraint configuration. After locating himself in the workstation, the crewman found that his boots tended to slip out of the foot restraints while he reached to open the canister doors or retrieve the film magazines. Since his knees were approximately six inches above the knee rests, excessive effort was required to reach the magazines. Also the handrail did not provide sufficient stability to perform the task (Figure 48). After evaluation of the test results, it was determined that the foot restraint concept was inadequate, and a different handhold arrangement would be required. The test, however, provided additional information on the workstation design requirements with respect to canister rotation, foot restraint position and reach envelope.

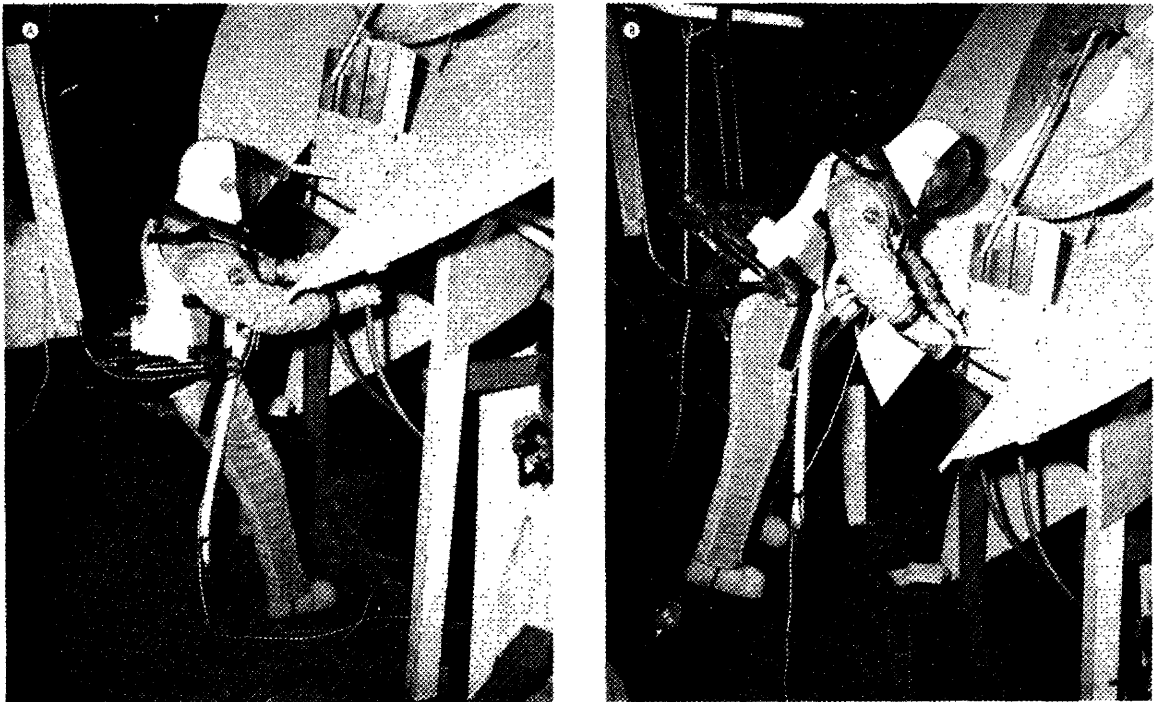

Figure 47. Sun-End Workstation Ingress Problems

By early September 1968, further studies resulted in definition of the sun-end workstation design requirements for optimum location of the crewman (Figure 49). All of the earlier workstation designs, while avoiding the permanent mounting of structure to the ATM sun-end surfaces, could not locate the crewman properly. The location and shape of the solar shield constantly interfered with the workstation location. The structure required for mounting the folding platform type of workstations to clear the

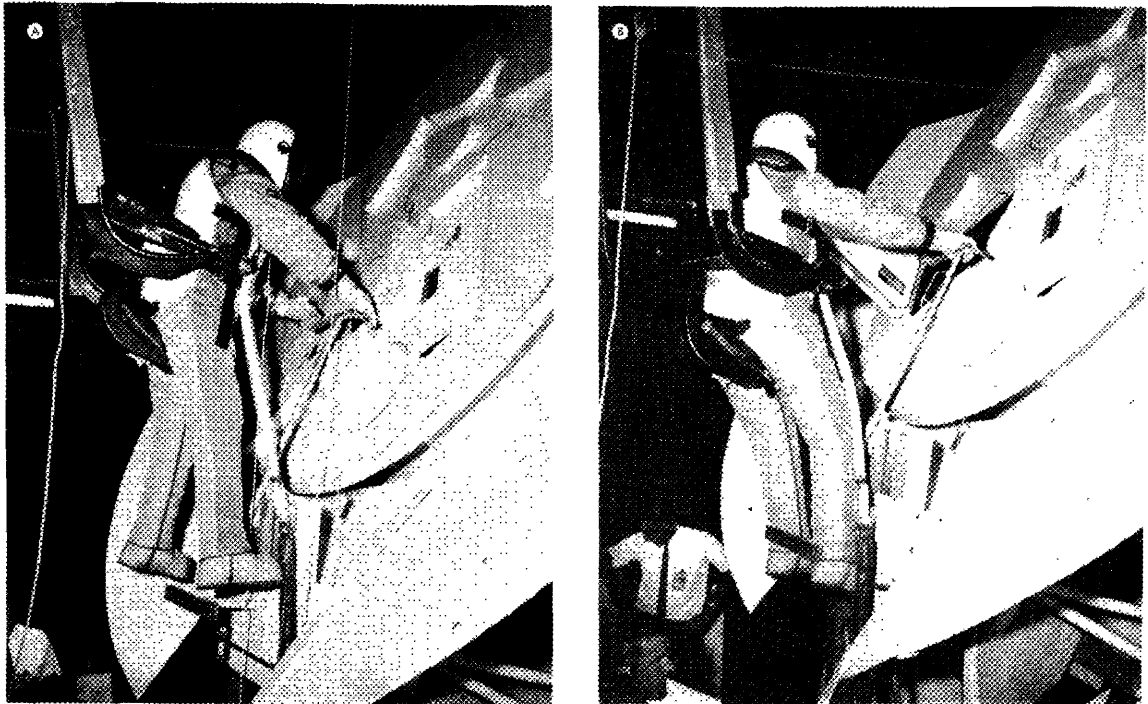

Figure 48. Workstation Foot Restraint and Stability Problems

solar shield violated the envelope restrictions imposed by the launch configuration of the SLA shroud and the ATM conical withdrawal envelope. Two possible solutions were investigated. One solution required cutting a section of the solar shield to allow mounting of a workstation closer to the canister. If the workstation was situated below the LM hatch, an opening in the shield would remove the thermal protection for a control moment gyro at that location. Therefore, the incorporation of such an approach seemed remote. The second solution involved continuation of the design of a deployable workstation. Because of the crew positioning, restraining, and stabilization problem, it was recommended that the workstation be deployed remotely at the LM end before the crewman translated to the sun end.

The proposed concept (Figure 50) reverted to the Gemini-type foot restraints which required a cut away in the solar shield section for proper crewman positioning. Handrails and a temporary storage rack for the film magazines were incorporated in the deployable solar shield workstation. Although the concept appeared feasible for access from the parallel rails, the translation and cargo transfer studies being performed concurrently had resulted in a promising concept for a manual rail translator device which would also serve as the sun-end workstation and, therefore, delayed further evaluation of the deployable workstation. Attention then centered on development of the translator or "trolley" concept.

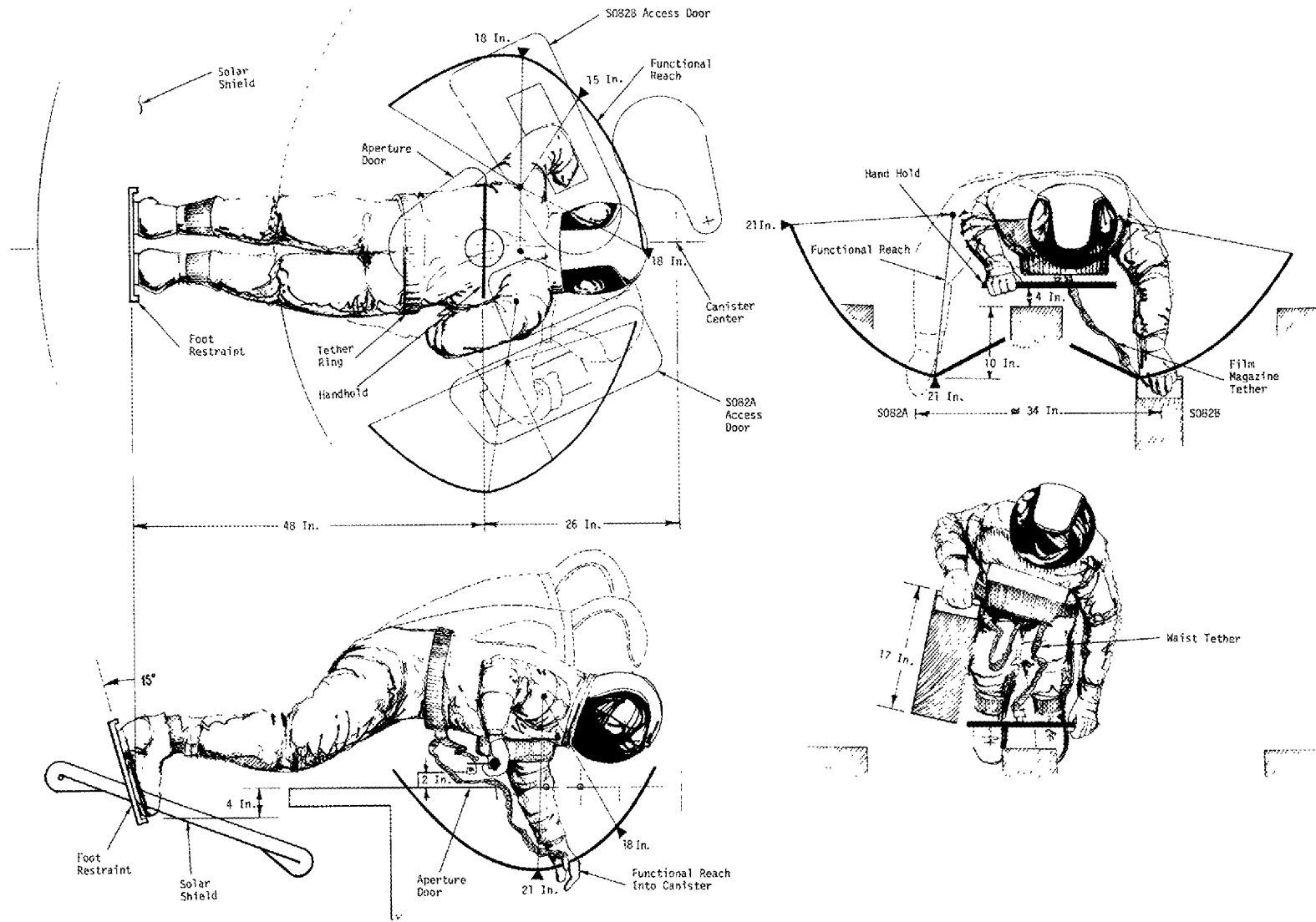

Figure 49. Sun-End Workstation Location Design Requirements

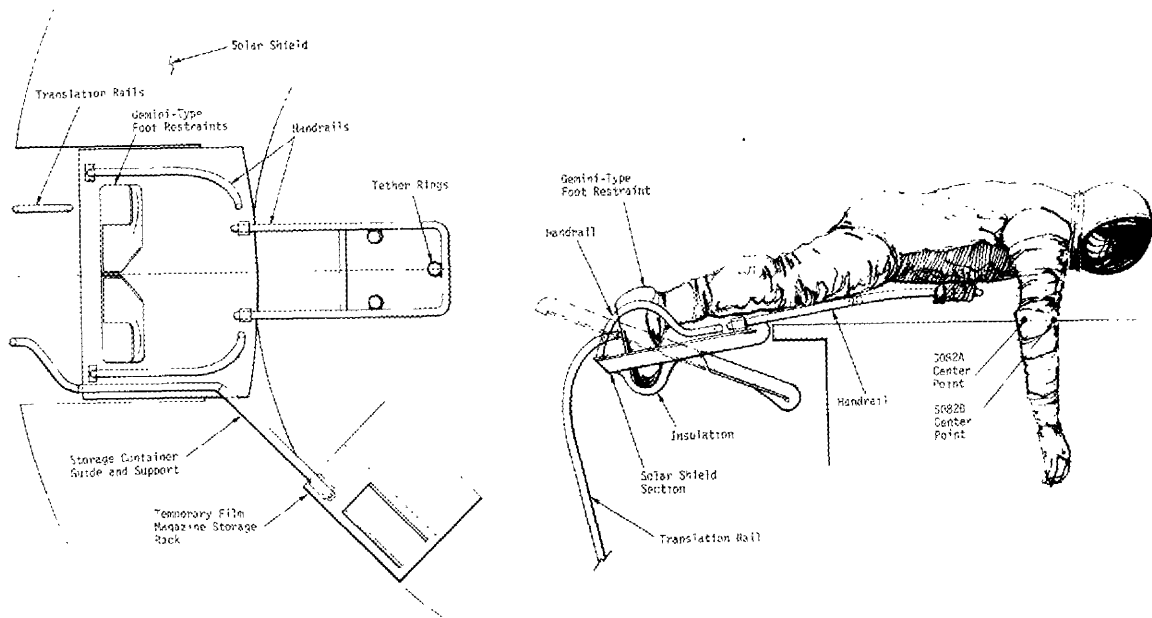

Figure 50. Deployable Sun-End Workstation Concept

The trolley concept offered the primary advantage of an integrated translation, film transfer and sun-end workstation device, incorporating the necessary tether attach points, hand holds and foot restraints (Figure 51). A translation rail, extending from the LM hatch, through the solar arrays and across the solar shield, provided a path to the sun end. The crewman would translate on the trolley to the sun end and lock the device to the rail to prevent lateral movement. He would then release and slide the foot restraint support forward through the translator body, thereby extending the hand holds and tether points across the face of the canister (Figure 52). With the canister rotated into position and the translator extended, the proper body relationship to the access doors and film magazines would be achieved. Rotating the film magazine carrier from its travel position on the foot restraint support would place the magazines within reach of the crewman for the retrieval operation. The translation and film transfer provisions of the trolley are discussed in Section IV.D. of the report.

As the concept was developed, it became necessary to provide structural supports for the translator rail on the solar shield surface. Modifications to the shield would also be required to provide clearance for the rail where it passed through the solar arrays and a flattened area to bring the trolley closer to the canister surface. The necessity for these modifications initiated a further analysis of the thermal control constraints which had prohibited the mounting of hardware on the ATM sun-end surfaces.

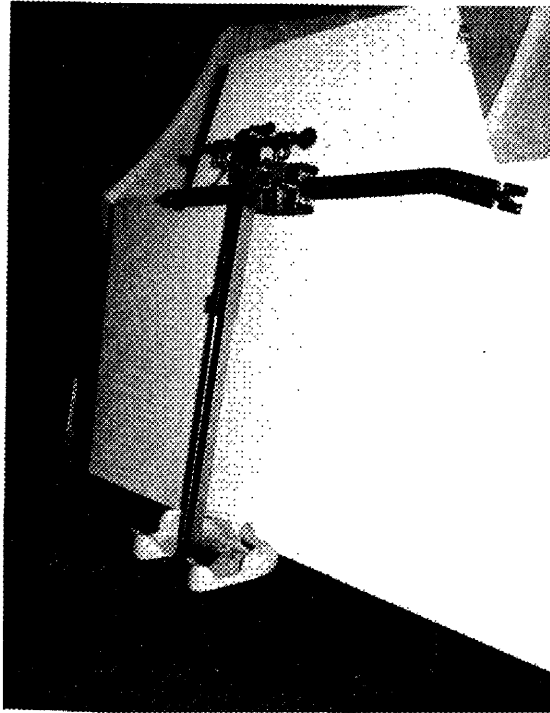

Figure 51. Trolley Translator Device

During January and February of 1969, the workstation development activities concentrated on preparation of an astronaut evaluation of the EVA system. The primary objectives were to demonstrate workstation concepts together with the two candidate film transfer and translation concepts, parallel rail system and trolley. This would determine the most feasible complete EVA film retrieval and replacement system for final design development. Because of the design requirements imposed by the translation concepts, problems were still being encountered in developing a workable sun-end workstation concept. With the workstation located directly below the LM hatch, the optimum canister rotation had been established at 24 degrees counter-clockwise, which placed the workstation centerline between the S082A and S082B film magazines within the canister. The major problems involved modification of the solar shield to provide clearance for the trolley or proper location for foot restraints and achieving stability for the crewman without attaching hand holds to the canister surface. It was determined that the solar shield would have to be flattened over a 56 degree arc in order for the crewman to reach into the canister with the translator device. The alternate parallel rail translation concept required that the solar shield workstation platform be relieved or "dimpled" for proper positioning of the foot restraints.

The sun-end workstation concept selected for use with the parallel rail system retained the basic concept of deploying the workstation by rotating a section of the solar shield, but incorporated a new hand hold

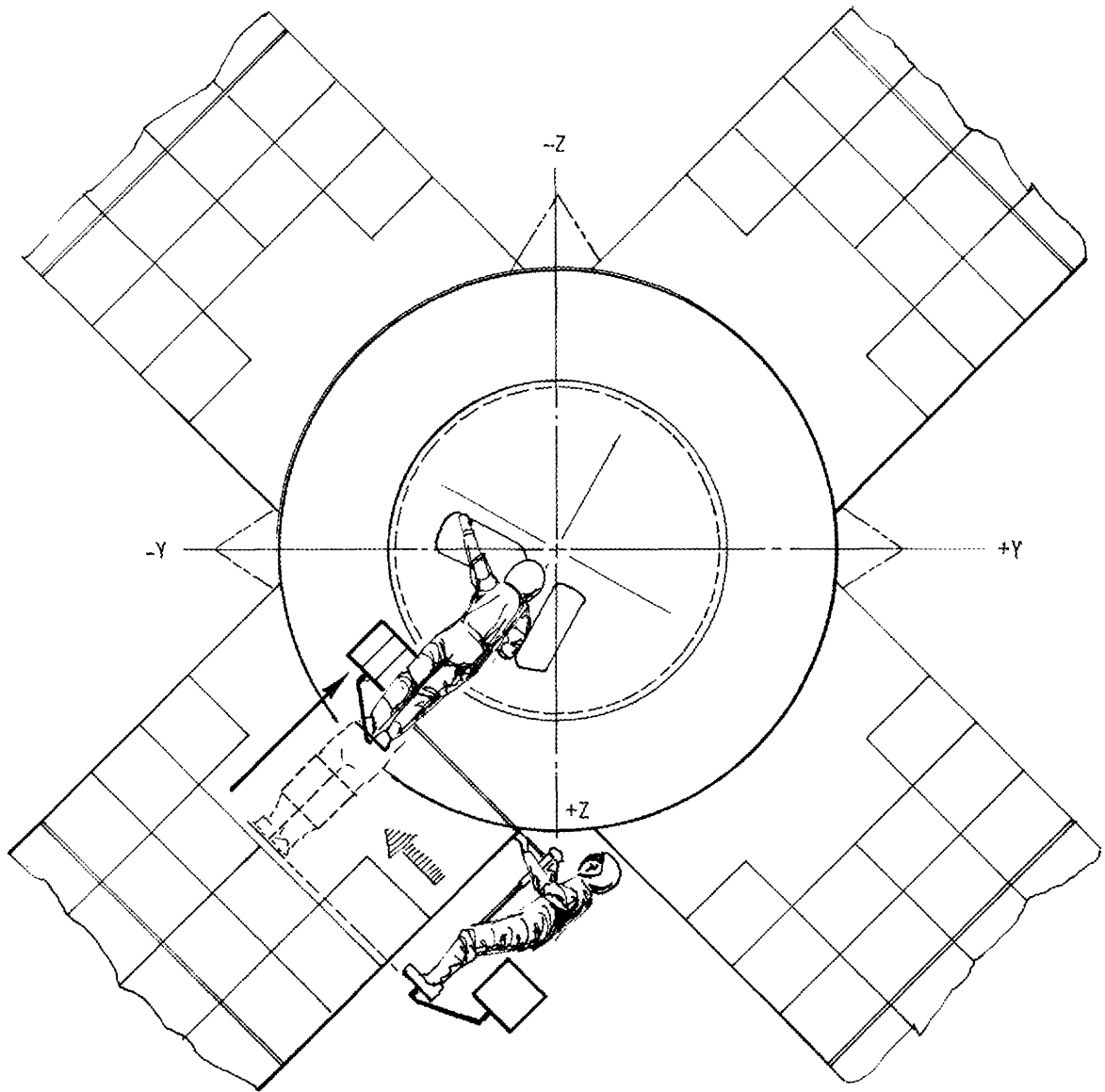

Figure 52. Trolley Sun-End Workstation Concept

and handrail configuration (Figure 53). Egress into the workstation was facilitated by the two handrails, which formed a continuous path with the translation rails once the workstation was rotated into position. Additional analyses and tests conducted on the canister thermal control systems in conjunction with the trolley mounting requirements had shown that the thermal effects of small hardware items mounted on the ATM sun-end surfaces were lower than had previously been anticipated. Also, any optical problems caused by light reflection from such hardware could be adequately controlled through surface coatings. As a result, the constraint was relaxed and two hand holds with tether rings were attached directly to the canister surface.

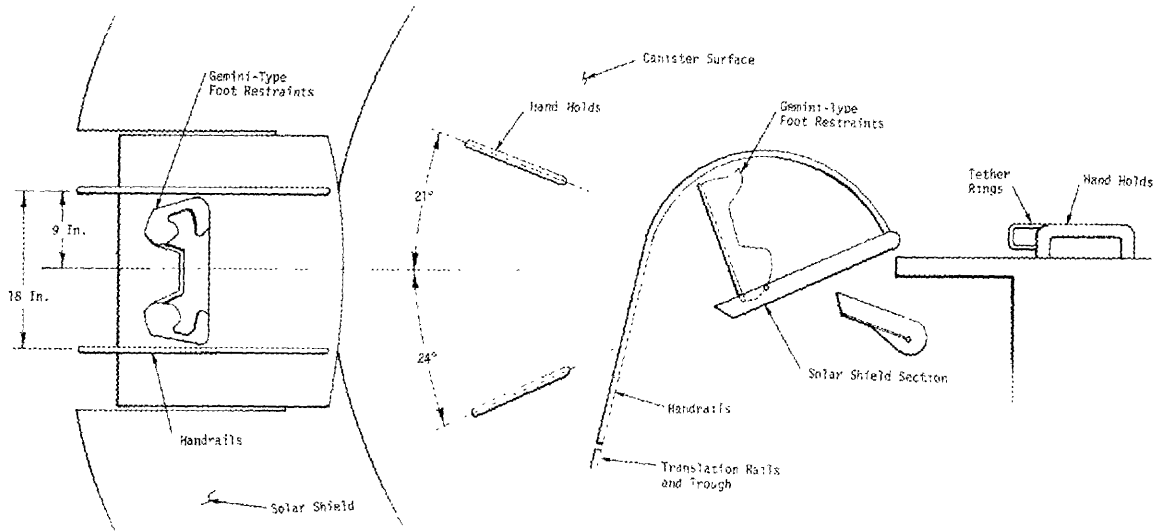

Figure 53. Deployable Sun-End Workstation with Canister Mounted Hand Holds

The crew evaluation, conducted in the MSFC neutral buoyancy facility during March 1969, was divided into two phases with an interval of two weeks between phases so that improvements could be made and additional astronauts could participate in the test. The problems experienced with the sun-end workstation were associated with location of the film transfer devices, hand holds and handrails. The Sun-end workstation was modified for the second phase of the evaluation to provide a location for a film transfer device (skateboard) rail and a reconfigured hand hold on the canister surface. The rotating solar shield section was eliminated because of the discontinuity with the translation rails and the foot restraint was permanently attached to the solar shield (Figure 54). Analysis of the crew evaluation tests resulted in selection of the parallel translation rails as the preferred EVA system design concept, and design effort concentrated on developing the workstation to achieve compatibility with the translation and film transfer equipment.

By August 1969, the sun-end workstation concept had been refined for the astronaut crew station review. Figure 55 shows the workstation configuration for the one-g phase of the review.

The crew experienced visibility, reach and equipment clearance problems during the review, because of the position of the S082 magazine protective canisters and foot restraints. The review also revealed that greater sensory feedback to the astronaut through the A7L pressure suit was required. Detents and over-center latches used on the canister access doors and film transfer devices needed more lock-unlock "feel". Visual feedback to indicate completion of a task, proper placement and direction of rotation in the form of higher visibility flags, more positive detents, painted instructions and color coding were also recommended for the film retrieval operation.

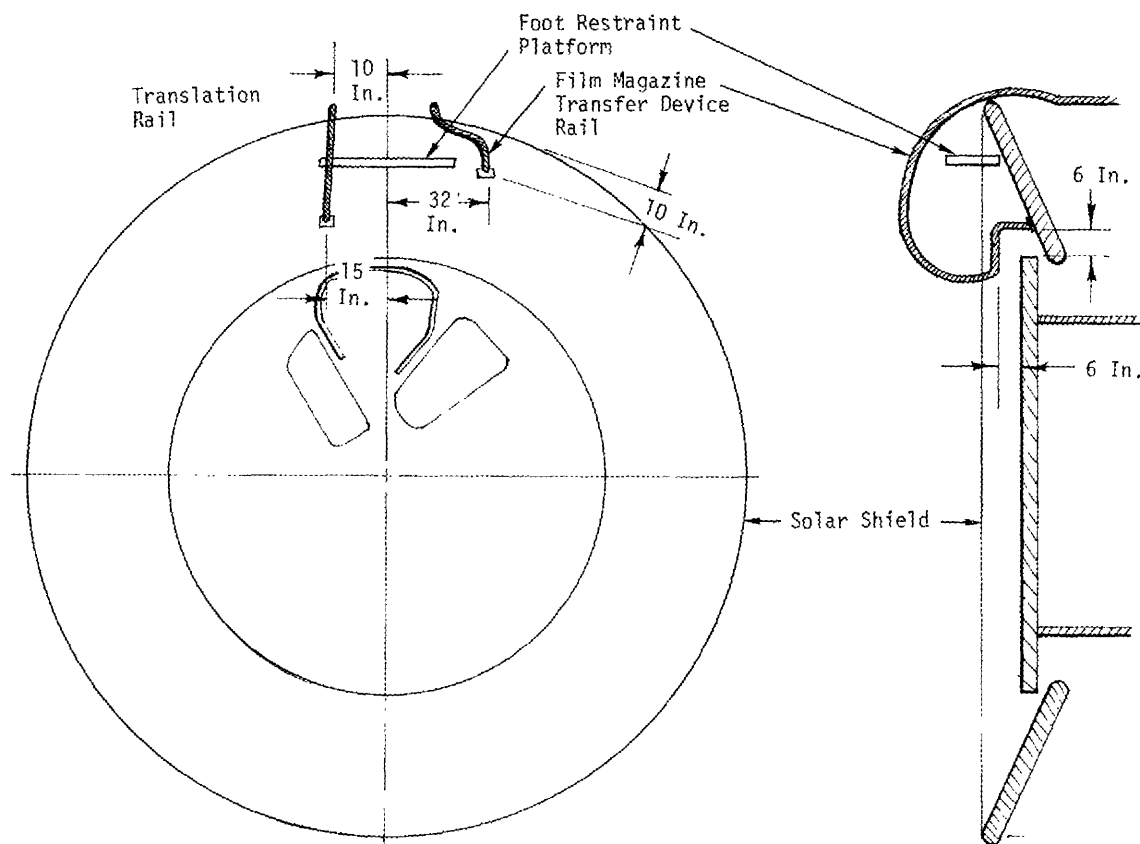

Figure 54. Permanently Mounted Sun-End Workstation

The simulations for the crew station review, although performed with the wet workshop configuration, had considered the dry workshop EVA requirements and provided the basis for proceeding with development of the system. Analyses of the review comments retained only those items relevant to EVA with the dry workshop, and work began to incorporate the results into the new configuration.

D. Transfer and Translation Concepts

The primary emphasis during this period in the EVA system development centered on establishing a feasible means of transporting the crewman and the film magazine cargo from the cluster egress location to the ATM workstations. When the decision was made to use the LM hatch for EVA egress, attention shifted to the use of rail systems which were simpler in design and construction than the earlier boom or serpentuator concepts. From the previous investigations, a manual translation system using fixed handrails was considered superior to any of the mechanical devices demonstrated thus far.

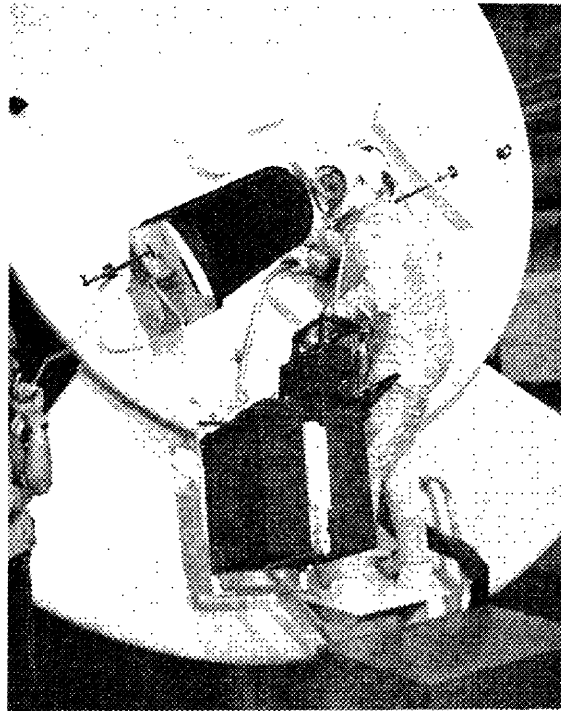

Figure 55. Final Wet Workshop Sun-End Workstation Configuration

The orientation of the LM hatch to the workstations still posed the problem of translating a considerable distance around the ATM and its hazardous structure and delicate components. Figure 56 illustrates a single translation rail concept and the distances involved in reaching the LM-end and sun-end workstations from the LM hatch. Cargo transfer would be very complex with this orientation. As a result, it was recommended that the LM-end workstation be moved to a position only 45 degrees from the LM hatch and the sun-end workstation positioned directly underneath the hatch. This could allow a simpler translation rail system for interconnecting the workstations (Figure 57). A means of protecting the solar arrays with a curtain was also envisioned. The method of film transfer conceived for the manual translation rail system would be a platform or dolly transport film carrier sliding along the handrail and propelled by the crewman.

The requirement that a translation system must preclude damage to ATM components or crew life support systems established a design for a combined cargo transfer and crew translation device. The proposed crew and cargo carrier would transport the crewman and film magazines along a single handrail from the LM hatch to the workstations (Figure 58). The carrier would restrain the crewman as he manually pulled himself and the carrier along the rail, thus avoiding crewman contact with the solar arrays. Since the concept offered the advantage of simultaneous transfer of both crew and equipment, work proceeded to develop a prototype for further evaluation as an alternate method to the rail translation and film magazine dolly concept.

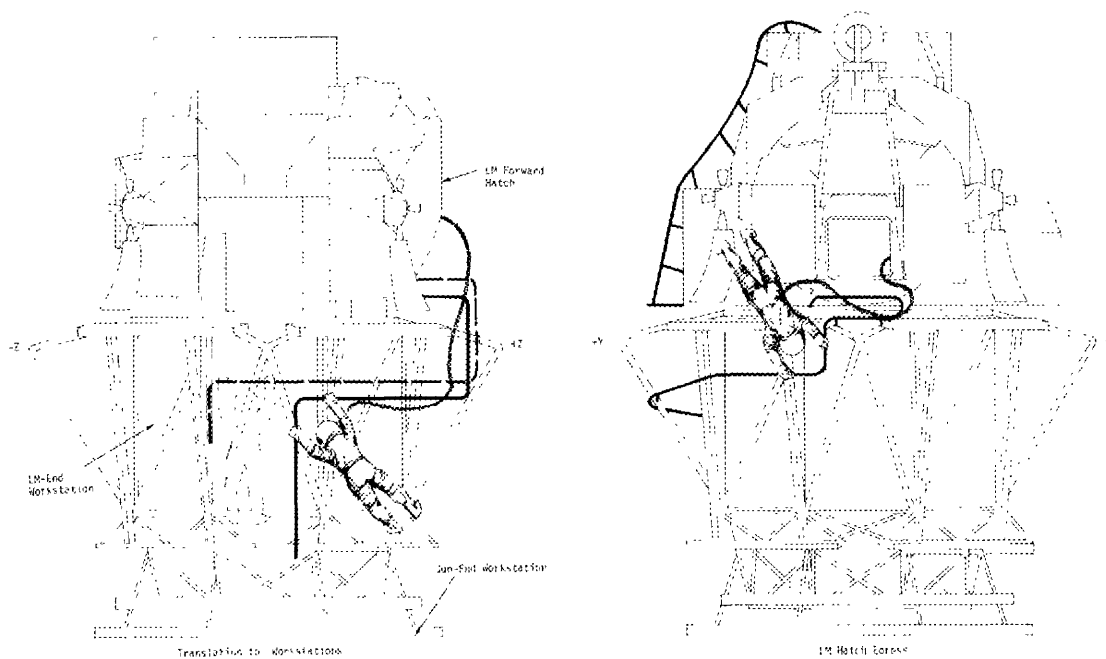

Figure 56. Single Rail Translation From LM Hatch

The change to egress from the LM hatch also required that a workstation be developed at the hatch so that the film magazines could be transferred from their stowage position within the LM-A to an interim location outside of the LM-A. During the period while EVA was performed from the AM hatch, two factors had prompted moving the stowage provisions for the film magazines to the LM-A. In the event the alternate mission became necessary, (the LM/ATM operating in a decoupled mode) it would be more advantageous to have the replacement film stowed in the LM-A. In addition, the MDA had been filled with workshop and experiment equipment. As a result, the LM-A was modified to include a Crew Provisions Stowage Module (CPSM) surrounding a docking tunnel extension, with space for the film magazines and EVA life support equipment.

When approval for relocating the workstations was received, it was decided to pursue development of the two most promising translation concepts - the parallel translation rail with the film magazine dolly or "skateboard" and the single rail crew and cargo carrier. The proposed parallel rail concept consisted of two translation rails extending from the LM hatch, across the side of the ATM outrigger truss, and down to the sun end with a deviation to bring the rails close enough for a crewman to transfer to the LM-end workstation (Figure 59). A film magazine dolly platform would slide along one of the rails and could be locked in position for film replacement. From previous translation evaluations and simulation tests on similar systems, the concept as proposed, would not provide adequate restraint for the crewman's feet while he passed through the solar arrays, nor adequate body control while he used one hand to propel the dolly. As the concept evolved, the rails were straightened and the addition

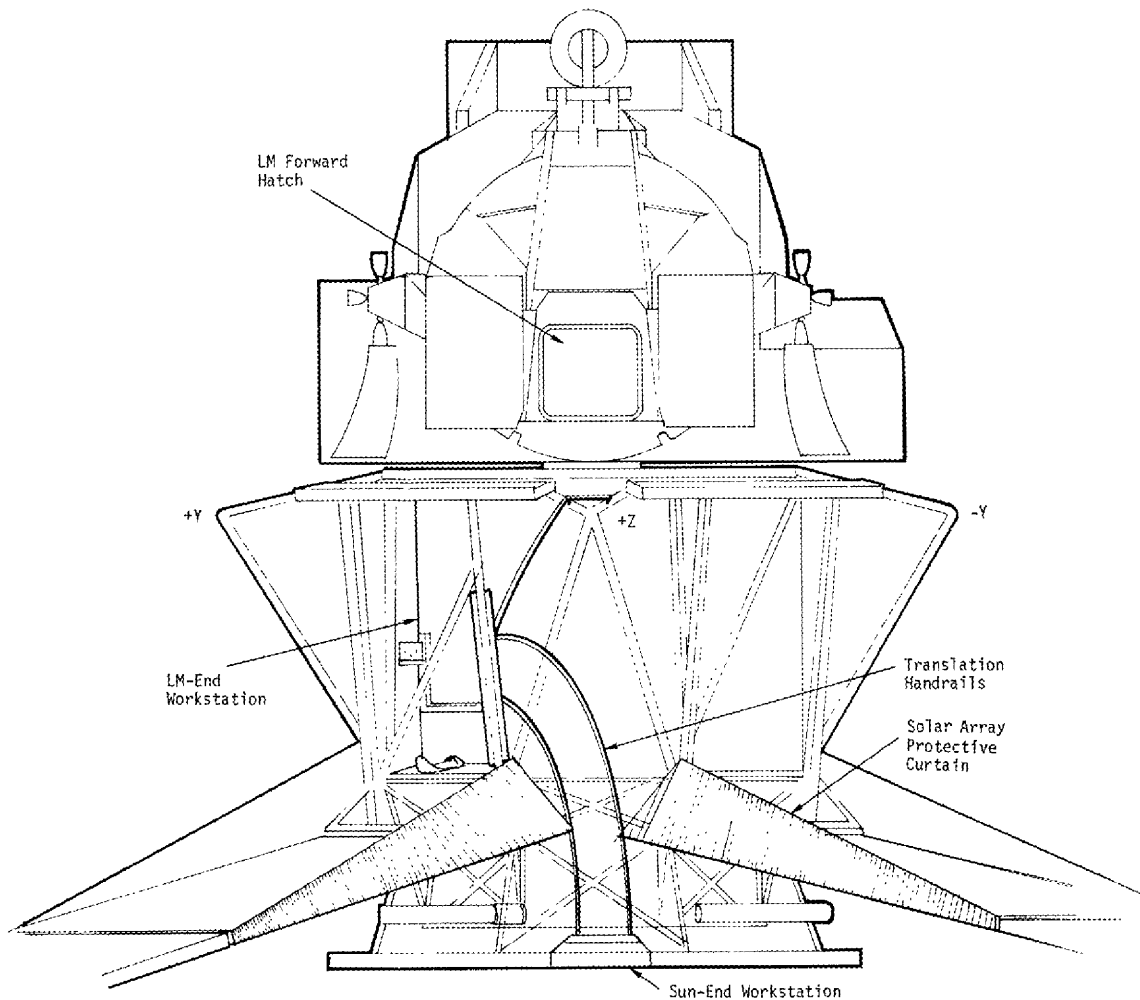

Figure 57. Proposed Workstation Relocation and Translation Rail Concept

of a trough between the rails was suggested as a means for foot restraint. Feasibility studies were then conducted in zero-g with the KC-135 aircraft to evaluate the ease of translation and stability with the trough. These studies showed that the concept had merit but further evaluation in neutral buoyancy in conjunction with the LM/ATM mockup would be required to assess the trough as part of the translation system.

Trade-off studies performed on various aspects of the proposed crew and cargo carrier concept established the methods of locomotion and film magazine transfer. The resulting design approach for locomotion was selected because it was the least complex and required the least physical exertion. The crewman located in a plane perpendicular to the translation

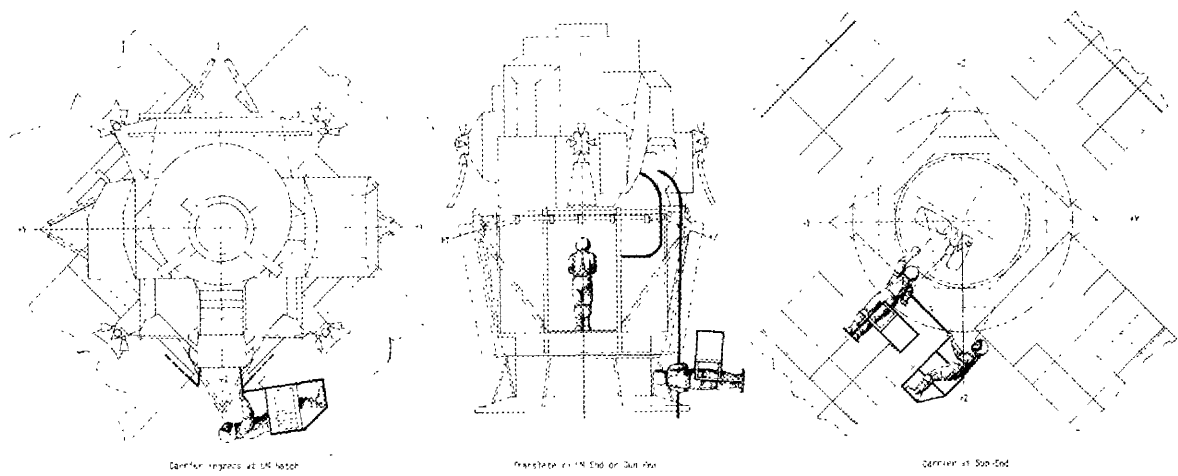

Figure 58. Proposed Crew and Cargo Carrier Concept

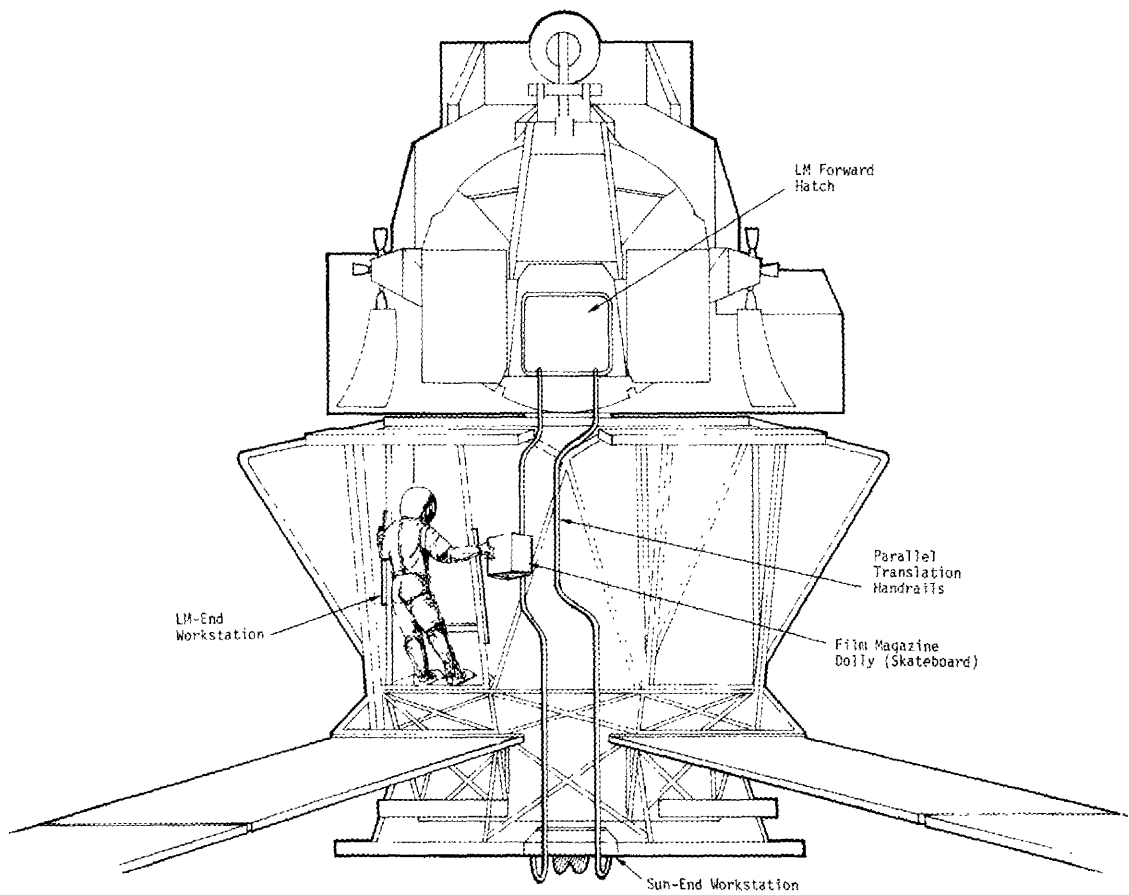

Figure 59. Parallel Translation Rails and Film Magazine Dolly Concept

rail would force the device along the rail with manual, hand over hand movements. A manually activated locking device would be required to lock the carrier at any intermediate point along the translation path. The cargo container would be fixed to the carrier, large enough to carry four film magazines to the LM end, and adaptable to carry two magazines to the sun-end. The carrier would be stowed adjacent to the LM hatch for launch and orbital operations with the container hinged to swing into a position that could be reached by the crewman in the workstations. The container would also include radiation protection for the film. The cargo carrier was designed to fulfill these requirements and was named the translator or "trolley" (Figure 60).

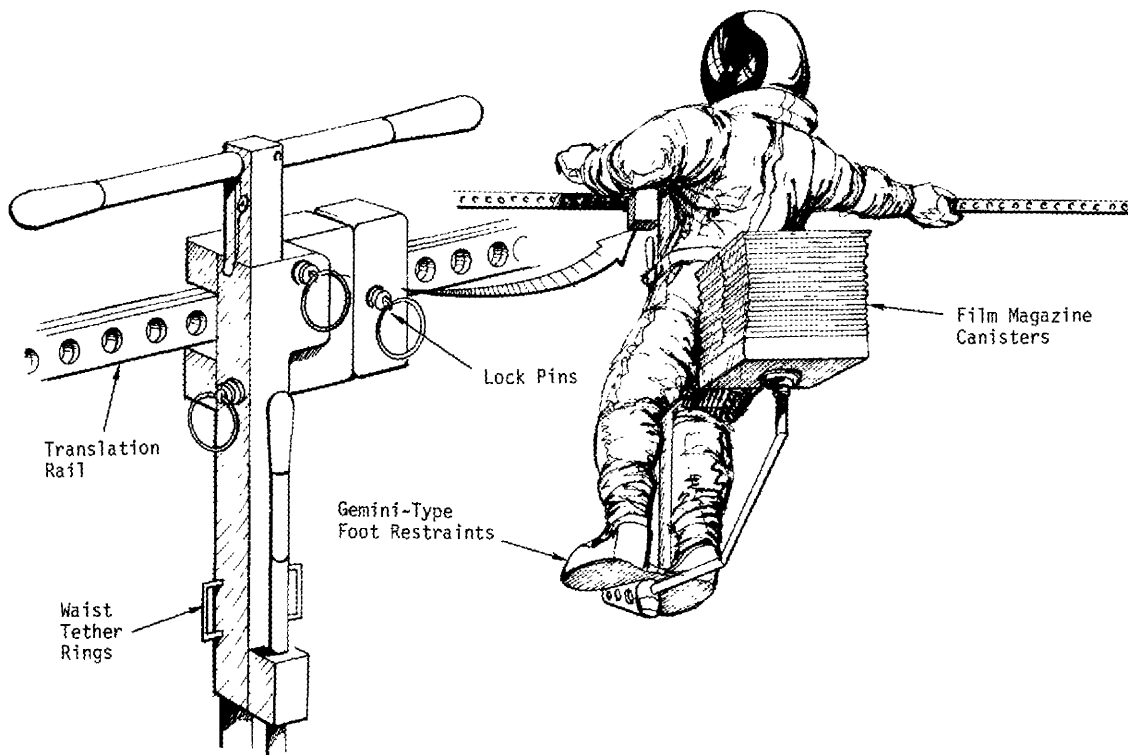

Figure 60. Translator or Trolley System

The translator design trade-off studies also considered methods of umbilical management during film retrieval. A stowage drum mounted on the translator was rejected because it imposed high metabolic loads for winding and unwinding the umbilical and would interfere with task performance. Film retrieval would also be difficult at the sun end from the translator. The accepted method would use the backup crewman to feed the umbilical out of the LM hatch and to control tension in the umbilical to prevent entanglement while the primary crewman clipped and unclipped the umbilical during translation. This method would relieve the primary crewman of the heavy burden of umbilical management.

A prototype trolley was fabricated and tested with several rail configurations to determine the optimum rail cross-section and allowable bend radius. Numerous problems were encountered with binding in the roller system while negotiating twists and bends in the rail. During December 1968, the trolley system was evaluated in conjunction with the development of the LM hatch workstation concepts (Figure 43). Although the trolley was considered unacceptable for use as the LM hatch workstation, development continued on the trolley as a sun-end workstation device.

Concurrent studies of transfer of the film magazines from inside the LM-A to the LM hatch workstation had involved devices for handling more than one magazine at a time. One of the designs selected for further development, on the basis of KC-135 zero-g simulations, was called the LM interim stowage device or "LM tree". The concept provided a secure mounting platform for a complete set of ATM film magazines and could be loaded within the LM-A during the pre-EVA preparations (Figure 61). The zero-g simulations had demonstrated the feasibility of the backup crewman passing the loaded LM tree through the hatch to the primary crewman at the workstation without exceeding the reach limits imposed by foot restraints and waist tethers. In addition, the LM tree could easily be adapted for installation on the trolley translator device. Figure 62 shows this concept at the LM hatch workstation. Results of simulation tests, conducted in January 1969, disclosed that placement of the tree on the trolley was extremely difficult because the proximity of the device to the crewman inhibited accessibility and alignment. Film magazine transfer at the LM-end workstation was unacceptable as the crewman could not reach the stowed S052 magazine on the trolley mechanism.

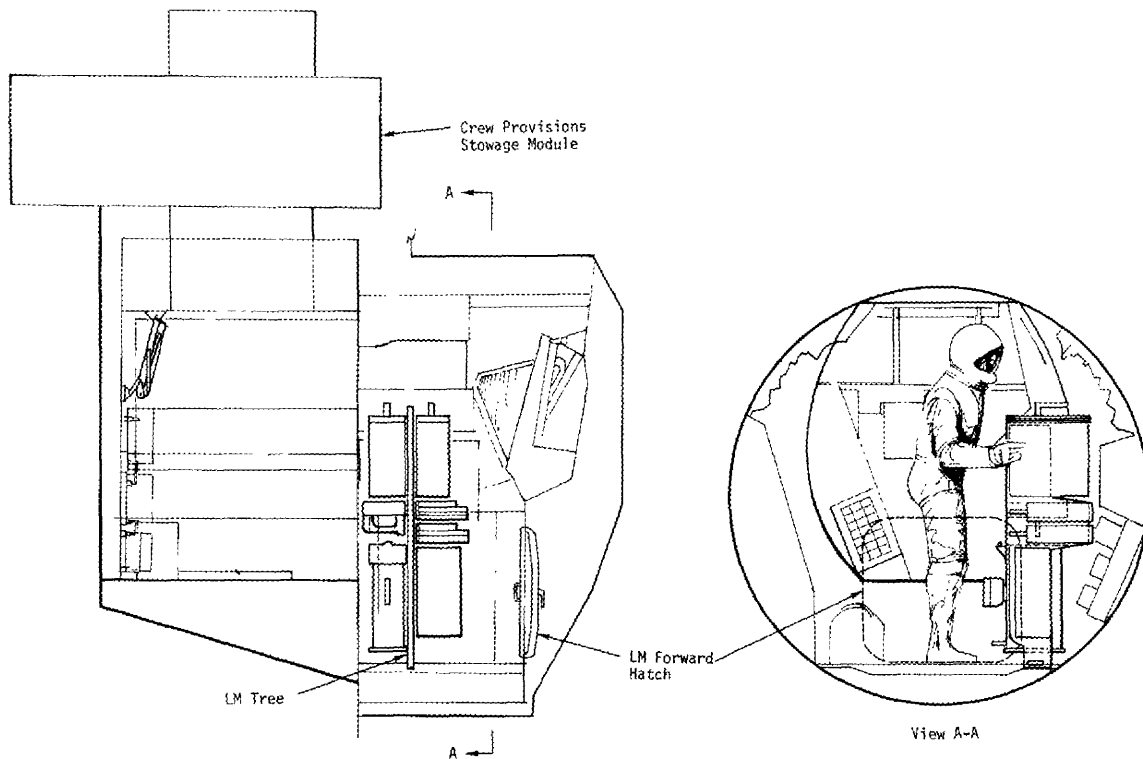

Figure 61. LM Interim Stowage Device in LM-A Forward Cabin Loading Position

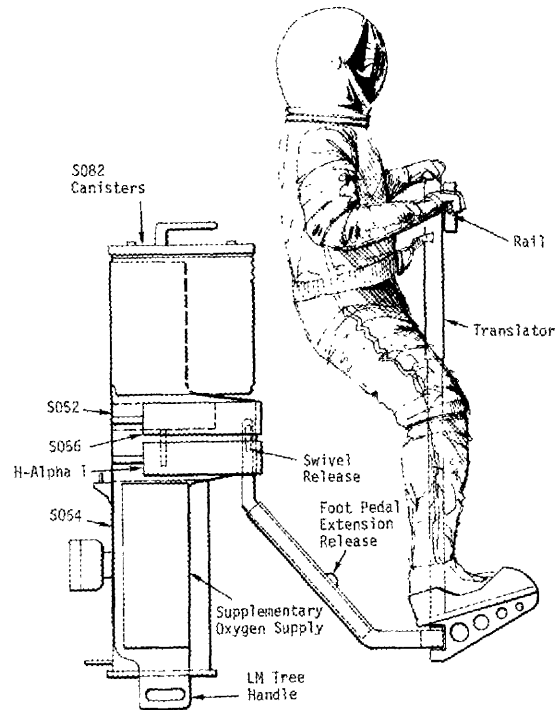
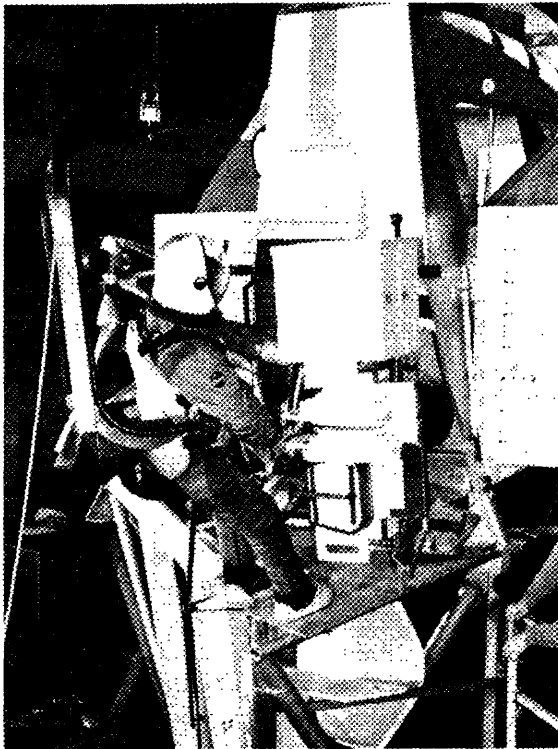
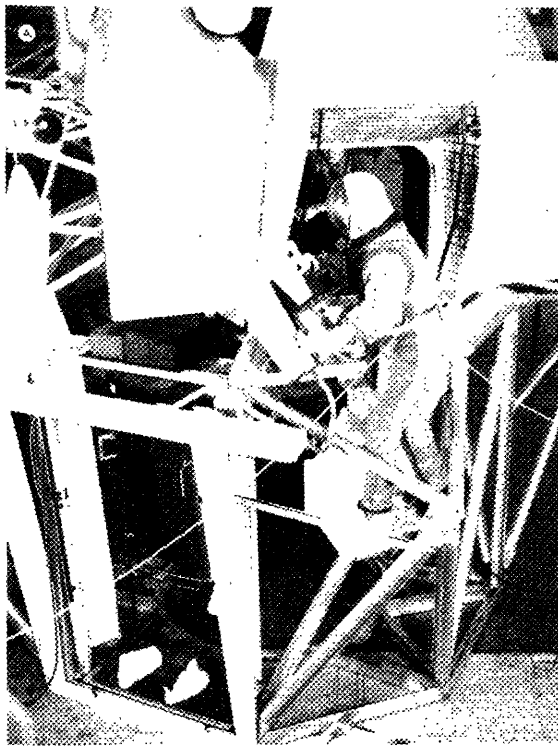

Figure 62. LM Interim Stowage Tree Attached to Trolley Translator

The same series of simulation tests were also to evaluate a pivoting arm concept for film transfer from the LM hatch to the LM-end workstation and to determine the location for a temporary film stowage platform at the LM end. The pivoting arm or "slip-over device", located at the left side of the hatch, was designed to carry a film magazine tree with the replacement magazines for the LM end. The crewman at the LM end would transfer the magazines from the device to the stowage platform at the right side of the workstation for the removal and replacement operation. Figure 63 illustrates the concept during performance of the test. Although the crewman's right arm blocked his vision while he positioned the film package on the device, the task was executed with ease and was considered a one hand operation. The relative position of the device to the crewman at the LM-end workstation and the location of the temporary stowage platform proved adequate.

A comparison of the evaluation results for the flip-over device and the trolley indicated the superiority of the flip-over device for transporting film magazines from the LM hatch to the LM end. Subsequent trade studies resulted in selection of the slip-over device for LM-end film retrieval. Investigations continued to determine the best locations for the magazines on the device and to incorporate locking and actuation mechanisms. It was also decided to use the trolley cargo carrier for transporting only the sun-end film magazines in their protective canisters. One advantage of the slip-over device was that it would fulfill the LM-end film transfer requirements for either the trolley concept or the parallel rail concept.



LM Hatch Position

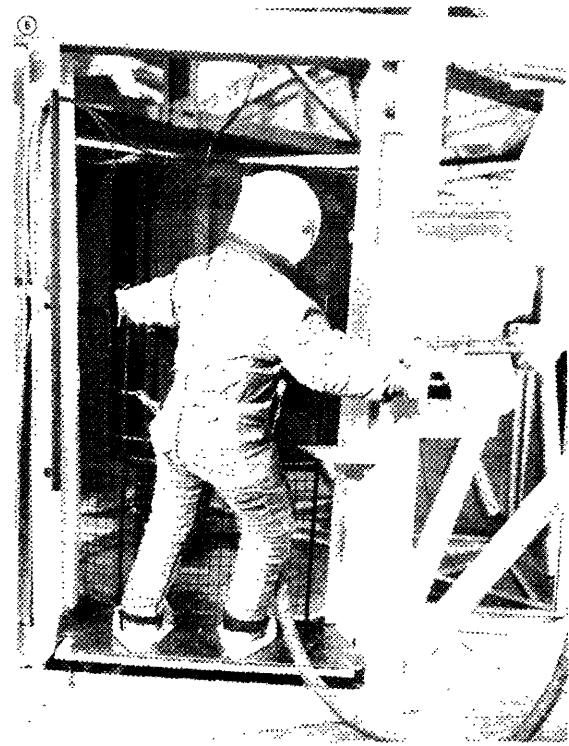

LM End Position

Figure 63. LM-End Film Transfer Flip-Over Device

Feasibility tests with the parallel rail and trough concept were performed in the neutral buoyancy facility during January 1969. The tests included translations from the LM hatch to each of the workstations, a stability evaluation of the trough foot restraint, and a simulated emergency retrieval of an immobilized crewman from the sun end. While attempting to transfer into the LM-end workstation, the crewman could not reach the workstation handrails without first grasping the surrounding equipment racks or solar array backup structure. During translation between the LM-end and the sun-end workstations, the trough controlled the crewman's feet as he passed through the solar arrays. However, the shape of the trough handrails did not provide an adequate grip for carrying a film magazine. When the crewman inadvertently released the handrails, it was possible to regain a hand hold by exerting torque with his feet against the trough (Figure 64). Analysis of the test results showed that the trough was an acceptable method of restraining a crewman's feet while he passed through the solar arrays, but the handrail and hand hold configuration needed to be revised. This test also provided the first indication that umbilical clips or guides did not appear necessary if the backup crewman maintained a slight tension on the umbilical from the LM hatch.

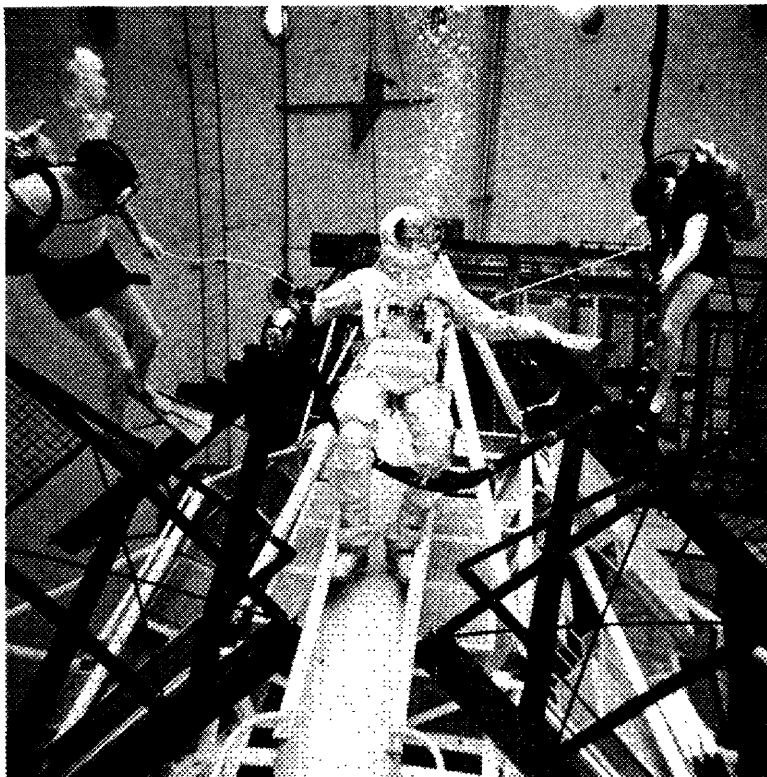
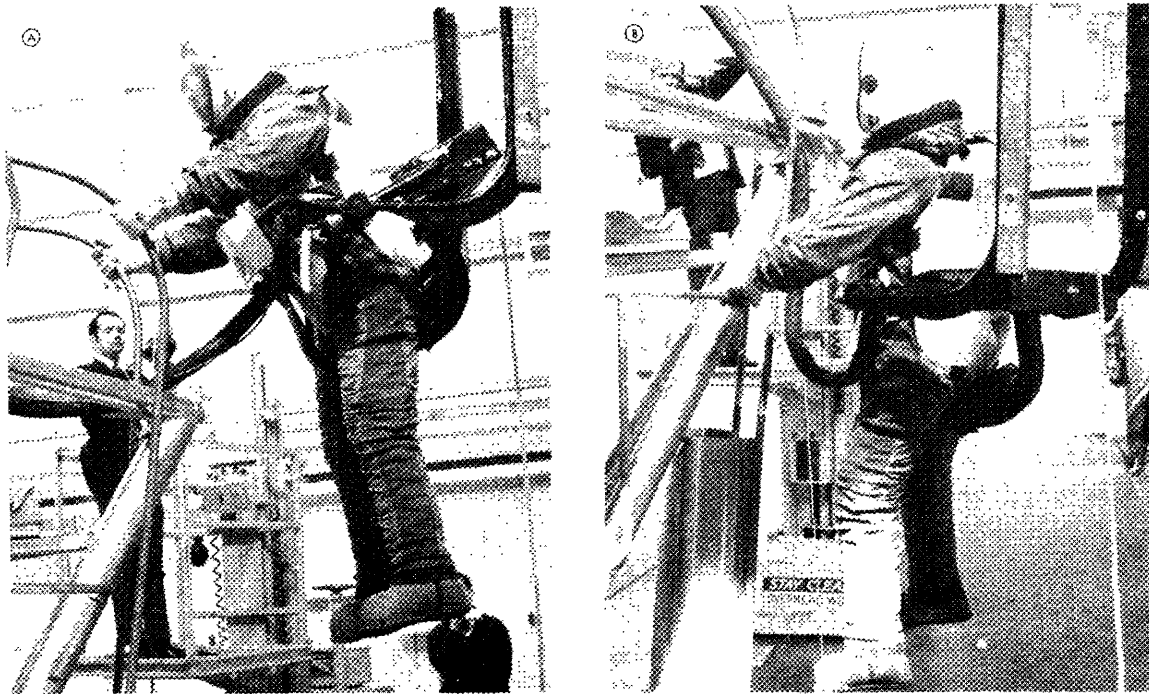

Figure 64. Neutral Buoyancy Stability Evaluation of the Trough Foot Restraint Concept

Development of the parallel rail concept continued through February 1969, in preparation of an astronaut evaluation. During multiple degree-of-freedom simulations with the one-g mockup, translation across the apex of the ATM outrigger truss, straddled by the parallel handrails, proved to be the best route from the LM hatch to the other workstation. The lateral transfer from the parallel rail system into the LM-end workstation was solved by the addition of a "T-bar" handrail at the truss structure. Figure 65 illustrates the parallel rail concept for translation between the LM hatch and LM end. With the translation route established, studies continued to select a compatible technique for the sun-end film transfer. Previous experience with the film carrier dollies resulted in a film transfer device called the "skateboard". One of the parallel handrails was modified to provide a continuous track between the LM hatch and the sun end on which the skateboard could be manually propelled. The two film magazines in their canisters would be attached to the skateboard at the LM hatch workstation and pushed or pulled along the track by the crewman. While the crewman replaced the LM-end magazines, the skateboard could be locked on the track adjacent to the workstation. At the sun end the skateboard would be located on the left side of the workstation within reach of the crewman.



Translating Across Outrigger Truss Lateral Translation to LM End With
T-Bar Handrail

Figure 65. Parallel Translation Rail Simulation Test

The configuration of the parallel rail translation and film transfer system, as it appeared for the March 1969 astronaut evaluation, is shown in Figure 66. The trough was fabricated of open-wire mesh and renamed the "coal chute". The envisioned method of actuating the flip-over device was by a hand crank operated at the LM hatch workstation. The film magazines were arranged in two packages on film trees, one for the LM end and one for the sun end. The components of the system were installed on the neutral buoyancy mockup so that the astronauts could perform the complete film retrieval task sequence. The translator or trolley device was fabricated as a separate part task mockup for the neutral buoyancy evaluation and consisted of several feet of straight section rail and one 90 degree bend about a 12-inch radius.

The astronaut evaluation was conducted in two phases during March 1969, and resulted in selection of the parallel rail system as the preferred design concept. Although the trolley system provided excellent control of astronaut body position and allowed simultaneous transfer of both crew and equipment, it was quite complex, rather heavy, and the evaluation indicated that considerable development would be required to provide an easy rolling system. Cocking in the roller system from off-center loads applied by the crewman, especially in negotiating the curved section, was the basic problem. The combination of design, neutral buoyancy environment and operational characteristics made movement of the trolley along the rail extremely difficult and required an excessive expenditure of energy. In addition, the

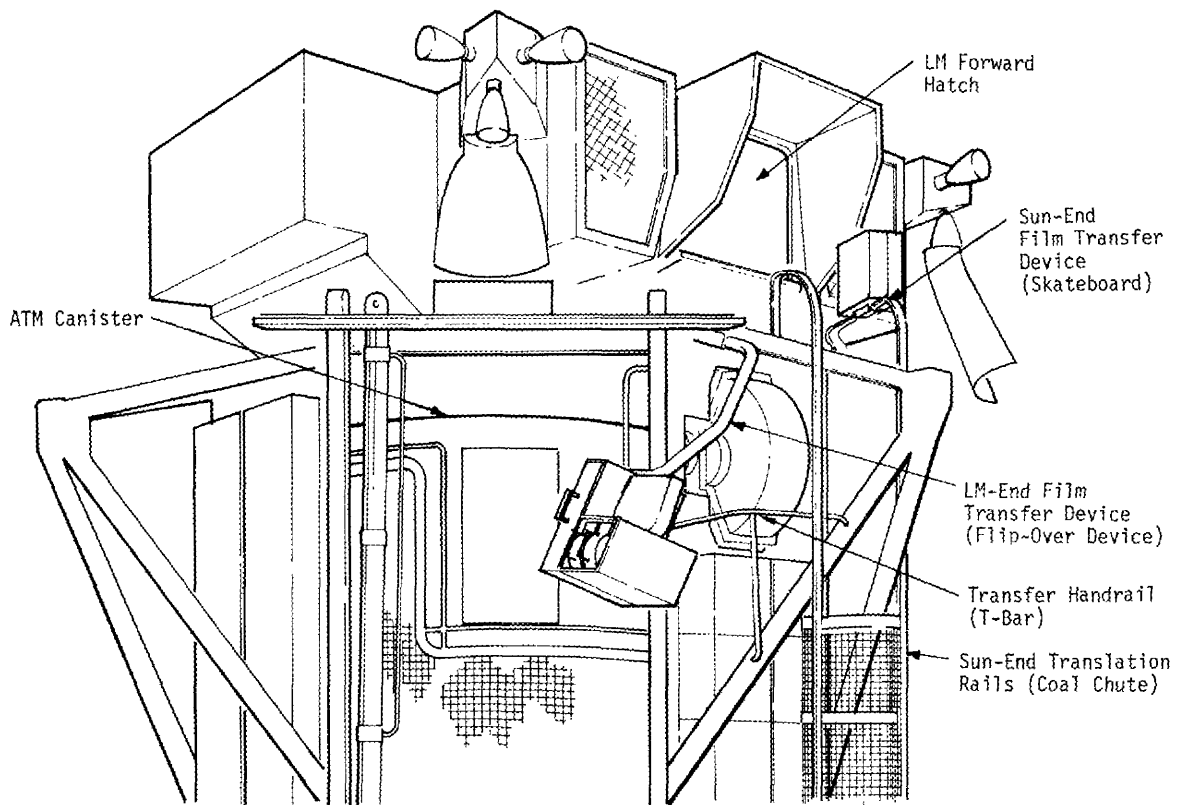

Figure 66. Parallel Rail Translation Concept and Film Transfer Devices

interface problems with the workstations and the necessity for flattening a segment of the ATM solar shield were contributing factors to the decision that development cease on the trolley.

The evaluation of the parallel rail system also included a backpack concept as an alternate or contingency method of sun-end film transfer. The backpack was eliminated from further consideration because it was too difficult to put on. A number of recommendations made by the astronauts for improving the parallel rail system were analyzed for possible incorporation in the design. The primary comments concerned establishing the optimum number of film magazines to be transferred at one time, making refinements in locating and operating the flip-over device, improving the parallel handrail configuration, and revising the film package latch mechanisms. It was also suggested that an alternate means of propelling the skateboard be devised.

Development and verification tests continued through the summer of 1969 in preparation for an astronaut crew station review. Analyses of the film retrieval operations were performed to define a procedure which would eliminate unnecessary changes in the crewman's body position while translating, transferring the film magazines, and during ingress and egress of the workstations. Figure 67 illustrates the preferred EVA film retrieval procedure as developed for the review. The hardware modifications included

an actuation lever with a locking mechanism for deploying the flip-over film transfer device, a magnetic film magazine retaining system with safety latches for the LM-end film tree, a tethering system for magazine handling at the workstations, and a revised translation system handrail configuration. The skateboard was outfitted with a crank-operated drum and cable system to evaluate the feasibility of using the backup crewman at the LM hatch to assist in the sun-end film transfer. The components of the EVA translation and film transfer system are identified in Figure 68.

The crew station review was held during August 1969. Because of the recent decision to launch a dry workshop, the review emphasized the film retrieval operations at the LM-end and sun-end workstations, the film package transfer equipment, and the crew translation provisions which could be used for the dry workshop. Translation, during the review, was accomplished with a minimum of problems, and the coal chute foot control system was not necessary for body restraint. The film magazine tethering system increased the crew workload, particularly at the LM end, where extensive tangling interfered with the operation. The temporary magazine stowage provisions were not within a comfortable reach envelope, and the S082 canister position substantially increased workloads at the sun end. The results of the review were incorporated in guidelines for design development of the dry workshop concept.

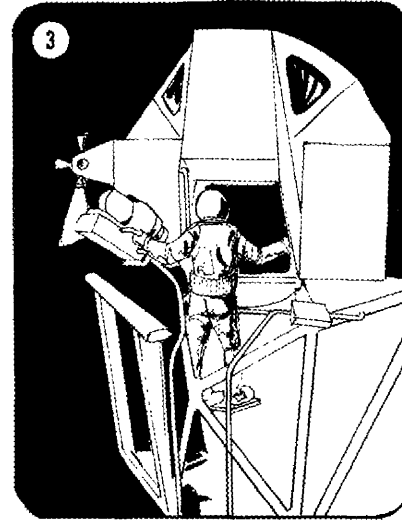
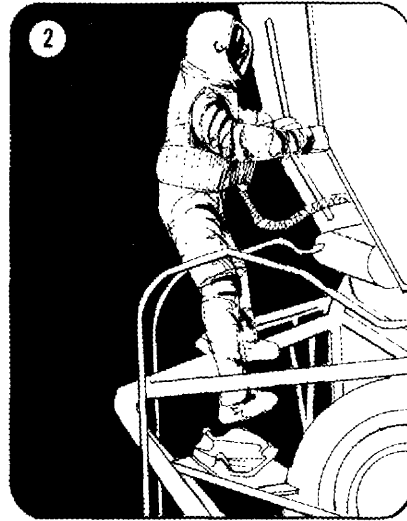
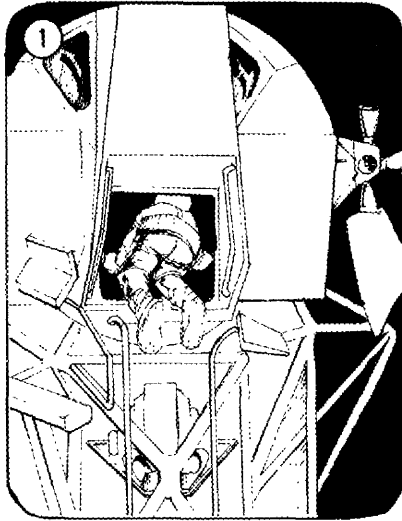

- 1 EGRESS LM-A EVA HATCH. MANEUVER TO LM-A EVA HATCH WORKSTATION.
- 2 PLACE FEET IN THE LM-A EVA HATCH WORKSTATION FOOT RESTRAINTS. ATTACH WAIST TETHER.
- 3 RETRIEVE LM-END FILM PACKAGE FROM LM-A HATCH. PLACE LM-END FILM PACKAGE ON LM-END FILM TRANSPORTATION DEVICE AND LOCK.

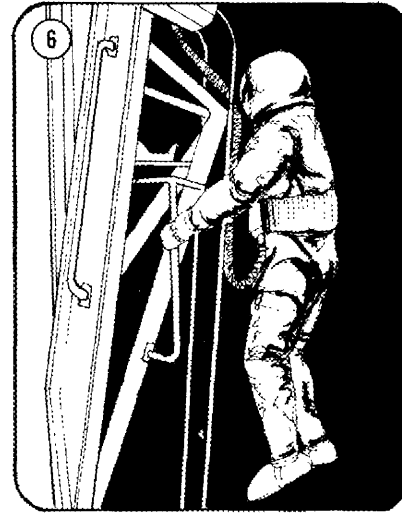
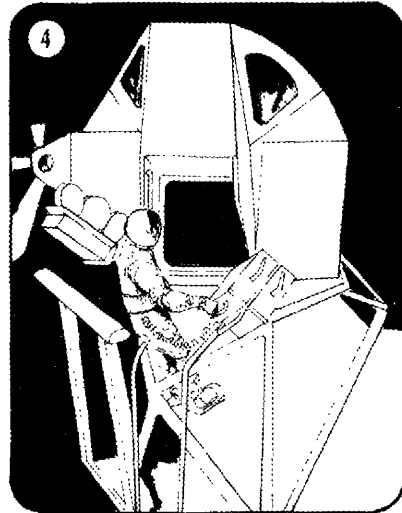

- 4 RETRIEVE SUN-END FILM PACKAGE FROM LM-A HATCH. PLACE SUN-END FILM PACKAGE ON SUN-END FILM TRANSPORTATION DEVICE AND LOCK.
- 5 EGRESS LM-A EVA WORKSTATION. TRANSLATE FEET FIRST TO THE LM-END WORKSTATION, CLIPPING UMBILICAL IN ITS RESTRAINING SYSTEM, PULLING THE SUN-END FILM PACKAGE.
- 6 SECURE SUN-END FILM PACKAGE IN TEMPORARY STORAGE POSITION. GRASP LM-END WORKSTATION HANDRAIL WITH LEFT HAND AND MOVE Laterally TOWARD LM-END WORKSTATION.

Figure 67. EVA Film Retrieval Procedure

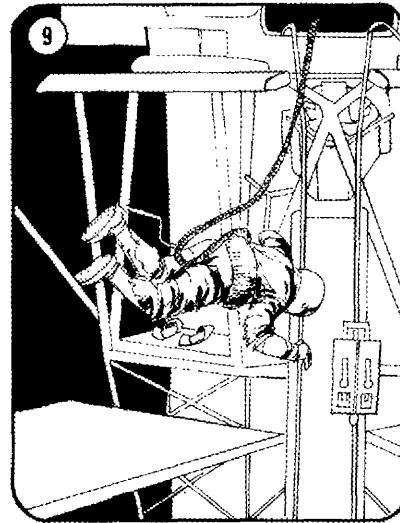
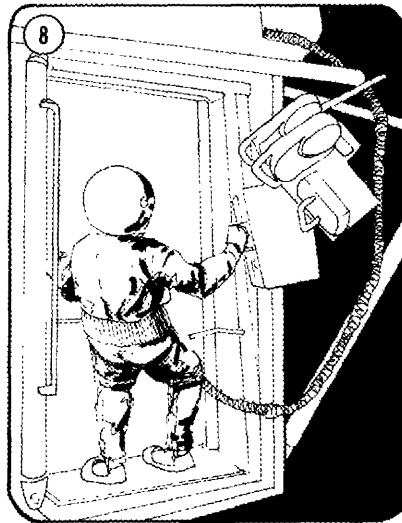

- 7 INGRESS LM-END WORKSTATION. ACTIVATE LM-END FILM TRANSPORTATION DEVICE UNTIL IT IS IN THE PROPER RETRIEVAL/REPLACEMENT POSITION.
- 8 PLACE NEW FILM MAGAZINE ON THE TEMPORARY STOWAGE PLATFORM AND PLACE THE EXPENDED FILM MAGAZINE ON THE LM-END FILM TRANSPORTATION DEVICE.
- 9 GRASP TRANSLATION RAIL WITH RIGHT HAND AND ATTACH WAIST TETHER TO THE SUN-END FILM TRANSPORTATION DEVICE.

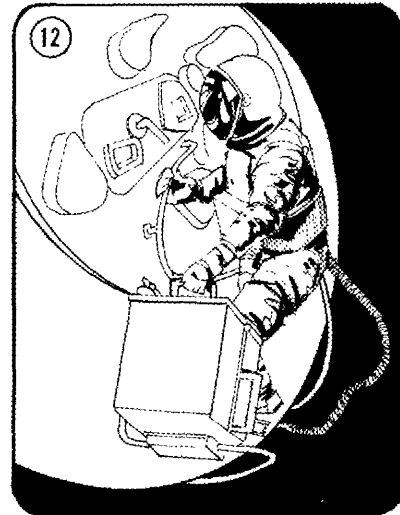
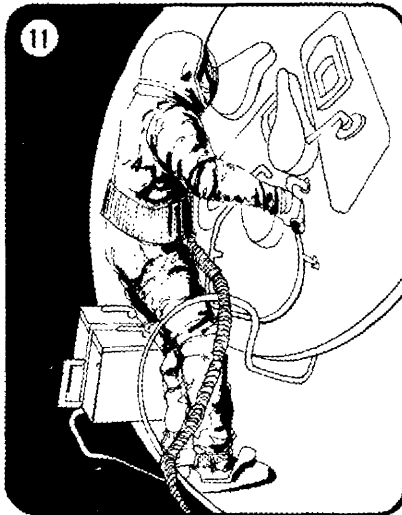
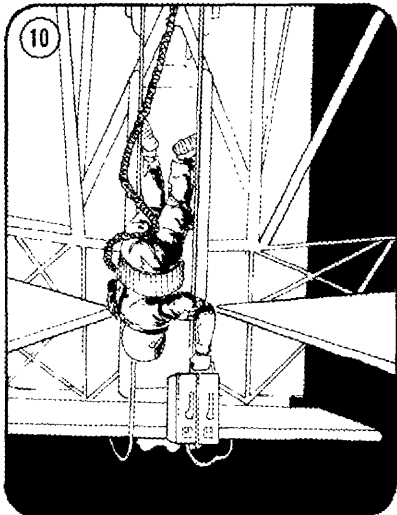

- 10 TRANSLATE TO THE SUN-END WORKSTATION, PUSHING THE SUN-END FILM TRANSPORTATION DEVICE.
- 11 POSITION AND LOCK SUN-END FILM TRANSPORTATION DEVICE AND INGRESS WORKSTATION AND FOOT RESTRAINT SYSTEM.
- 12 RETRIEVE/REPLACE SUN-END FILM MAGAZINE.

Figure 67. EVA Film Retrieval Procedure (Cont'd)

1. LM-end film package
2. LM-end film transfer device (flip-over)
3. Flip-over device actuation lever
4. Sun-end film transfer device (skateboard)
5. Skateboard crank-operated drum and cable system
6. Parallel translation rails
7. Coal chute foot restraint
8. Transfer handrail (T-bar)
9. Skateboard with S082 canisters
10. Sun-end workstation handrail
11. S082B film magazine in temporary stowage

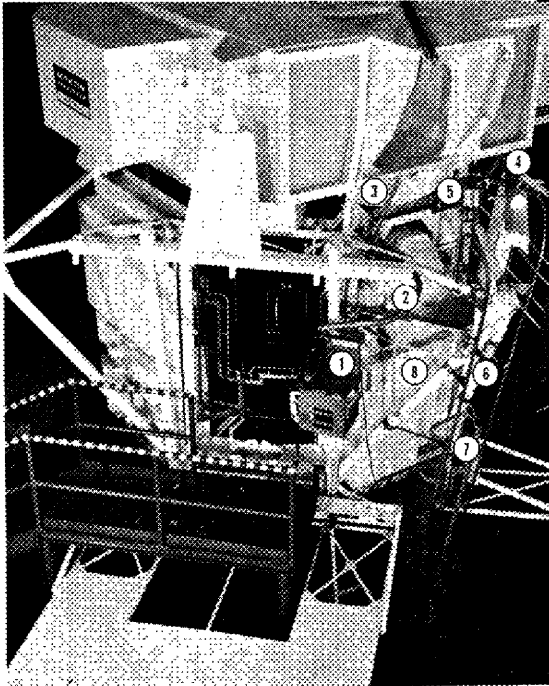

LM End

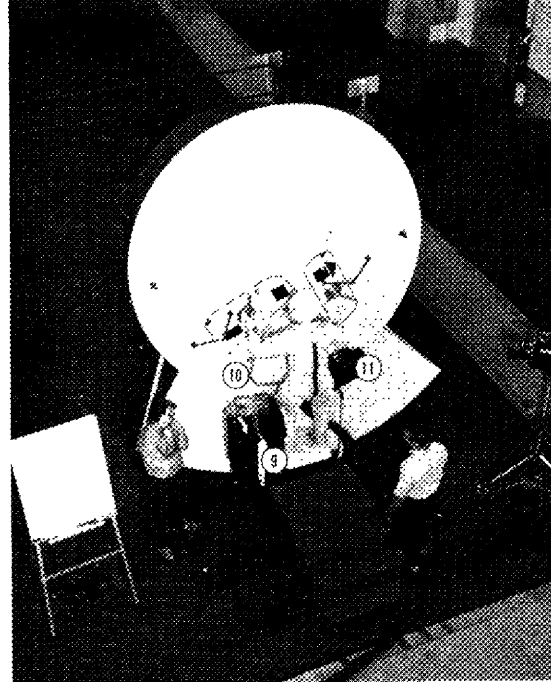

Sun End

Figure 68. LM/ATM EVA Translation and Film Transfer System

SECTION V. DRY WORKSHOP CONCEPT - EVA EGRESS FROM AM

The decision to use a Saturn V launch vehicle to place the S-IVB stage dry workshop with an integrated ATM into orbit eliminated the LM-A from the program. This change required the existing AM capability to be used for the ATM film retrieval EVA functions. In order to use the AM hatch for EVA egress, the translation and film transfer systems developed for the wet workshop would require modification to conform to the AM hatch location. In addition, temporary film magazine storage and crew mobility and stability aids would be needed at both the interior and exterior of the AM. A new storage area for the film magazines would also be required.

This section of the report covers the EVA development activities involved with the dry workshop concept, which would become "Skylab". Although design studies, during this period, continued using the one-g mockups with multiple degree-of-freedom simulators, neutral buoyancy became the dominant verification technique. When damping was deemed critical, because of viscous drag in the neutral buoyancy simulations, test results were verified in the KC-135 aircraft.

The Extravehicular Mobility Unit, consisting of an A7L-B pressure garment assembly (space suit) from the Apollo Program and an Astronaut Life Support Assembly (ALSA), was developed by Johnson Space Center for Skylab EVA. The ALSA equipment included a Life Support Umbilical (LSU), a Pressure Control Unit (PCU), and a Secondary Oxygen Pack (SOP). These components are illustrated in Figure 69.

A. Cluster Configuration

Deletion of the Saturn IB flight to place the LM/ATM into orbit eliminated many requirements associated with support for the LM/ATM launch, rendezvous and docking to the Saturn I workshop. However, the ATM support functions provided by the LM-A required equipment relocation to the other cluster modules. New structural support provisions were required to adapt the ATM to the Saturn V workshop for launch and in-orbit orientation. In addition, a payload shroud and eject mechanism had to be designed to protect the cluster components during launch.

These problems had been evaluated during the definition studies, and when the change to a dry workshop was approved, much of the preliminary design analysis and trade study work had already been completed on the cluster configuration. The major configuration trade studies required to develop the dry workshop concept for EVA involved the AM airlock work area and orientation of the AM hatch with respect to the ATM workstations. The preliminary analyses indicated that the present airlock volume for two suited crewmen and the film packages was marginal and would require further evaluation for possible expansion.

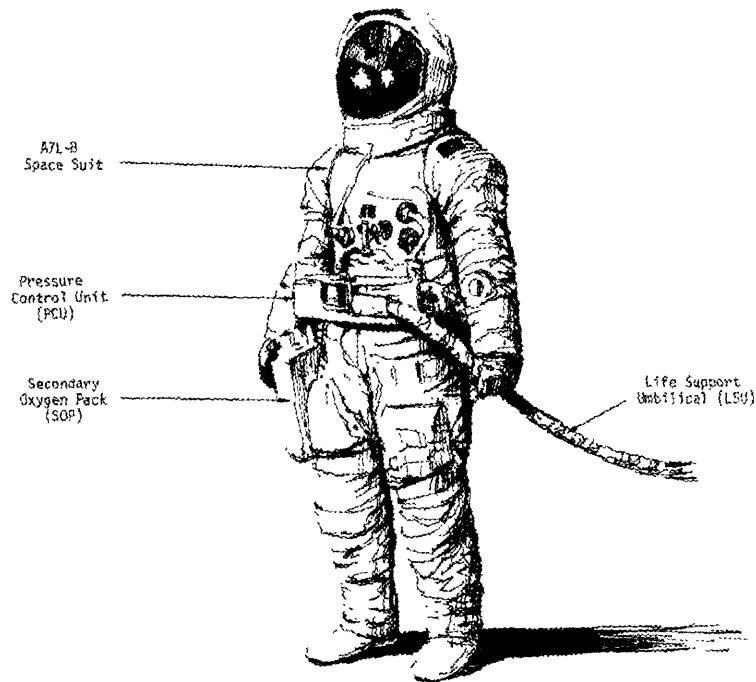

Figure 69. Skylab EVA Life Support System

The dry workshop concept eliminated most of the equipment transfer problems associated with workshop activation and left more available space within the MDA for experiment installation and stowage. One of the radial docking ports was removed as it was no longer needed for the LM-A. As the dry workshop design evolved, a deployment assembly was developed to support the ATM and the cluster configuration problems were resolved resulting in the final orbital laboratory called Skylab (Figure 70).

B. EVA Requirements and Guidelines

The primary changes to the EVA requirements resulting from the conversion to a dry workshop concept were the increased number of film retrieval operations to be performed. The new mission requirements specified three manned missions, during which the ATM instruments would collect solar data, instead of the single 56 day mission with the LM/ATM. The cluster equipment and experiment interfaces and operating systems were evaluated for compatibility to determine effects on design, and a Cluster Requirements Specification was developed. The EVA requirements contained in the EVA guidelines and constraints document were adopted as part of the specification to regulate design of the cluster systems.

The following requirements and guidelines represent the significant differences between those developed during the wet workshop era and those affecting the dry workshop EVA system development. The complete performance and design integration requirements for Skylab may be found in the Cluster Requirements Specification, RS003M00003.

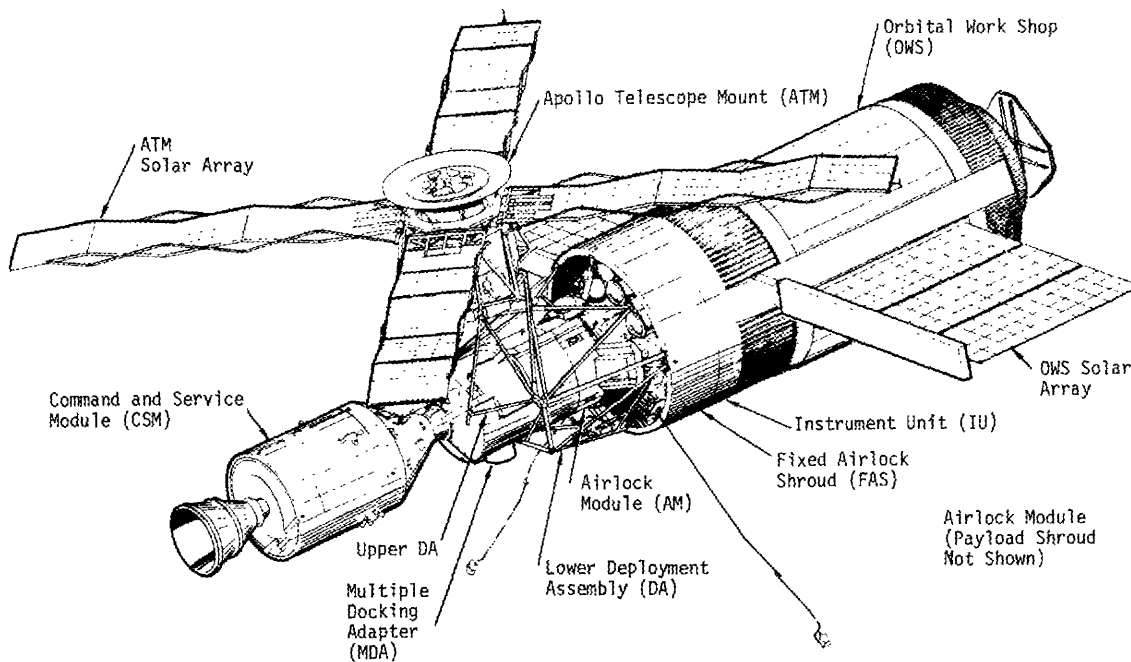

Figure 70. Skylab Cluster Configuration

1. Mission

a. A total of six film replacement and retrieval operations were planned for the three missions.

b. The maximum time for EVA would be three hours, exclusive of preparation and post EVA requirements. Maximum time to perform film magazine removal and replacement at the ATM would not exceed 2.5 hours (Design for 2.0 hours).

2. Cluster Egress and Ingress

EVA egress and ingress would be accomplished from the AM hatch.

3. Life Support System

The A7L-B pressure suit and Astronaut Life Support Assembly (ALSA) would be worn during EVA.

4. Safety

a. Astronauts had to be able to perform tasks after 50 days in space, and the workload had to be less than 1200 BTU/hour (800 BTU/hour was considered optimum).

b. Tethering of the crewman to structure was not required during translation to the workstations, or at a workstation when a positive

foot restraint system was available. The umbilical provided emergency restraint.

c. Tethering of equipment was not required when hard locks were provided, nor when transferring equipment from one locked location to another if both hands were available for the task. Tethering of equipment was required in all other conditions.

d. Astronaut translation should be accomplished independently of film magazine transfer.

e. The ATM gimbal ring would be secured during each film retrieval operation. (The requirement for a separate manual locking device was deleted.)

C. Workstations and Canister Access

The first few months following the decision to convert to a dry workshop were spent in refining the definition studies and analyzing the results of the crew station review held during August 1969. The major problems identified with EVA egress from the AM hatch in the initial configuration were the questionable volume of the AM for two astronauts, film magazines and associated EVA equipment, the design of the thermal curtain, and the lack of a clear path and line-of-sight from the hatch area to the ATM workstations. The thermal curtain problem was solved by redesign of the curtain in the AM EVA bay area to allow attachment around the EVA hatch.

Several approaches were studied to acquire a clear path and line-of-sight for EVA. In the original configuration, the AM hatch was oriented on the far side of the cluster from the ATM workstations. Figure 71 illustrates the problem and one of the proposed solutions which involved rotating the AM 45 degrees from its existing location. Another approach considered rotating the ATM 90 degrees about the cluster Z axis, to achieve a better orientation. In order to minimize the impact on design of the major cluster modules, a compromise orientation was adopted whereby the translation route and the sun-end workstation would be moved to the ATM +Y axis (Figure 72). This would bring the sun-end workstation to within 45 degrees of a direct line from the AM. The LM-end workstation, which had been renamed the "center workstation", although 90 degrees from the best location, would still be accessible for direct cargo transfer from the AM hatch area, and crew translation to and from the workstations still appeared feasible.

The marginal volume of the AM airlock tunnel presented a different situation. The only possible ways of expanding the working volume, without impacting the basic structural design of the module, were to relocate the aft airlock hatch or provide a reusable workshop hatch. The two proposed solutions for providing additional space in the tunnel are shown in Figure 73. Either method would allow use of the AM aft compartment during EVA with minimum changes to the module. A decision on the proposed

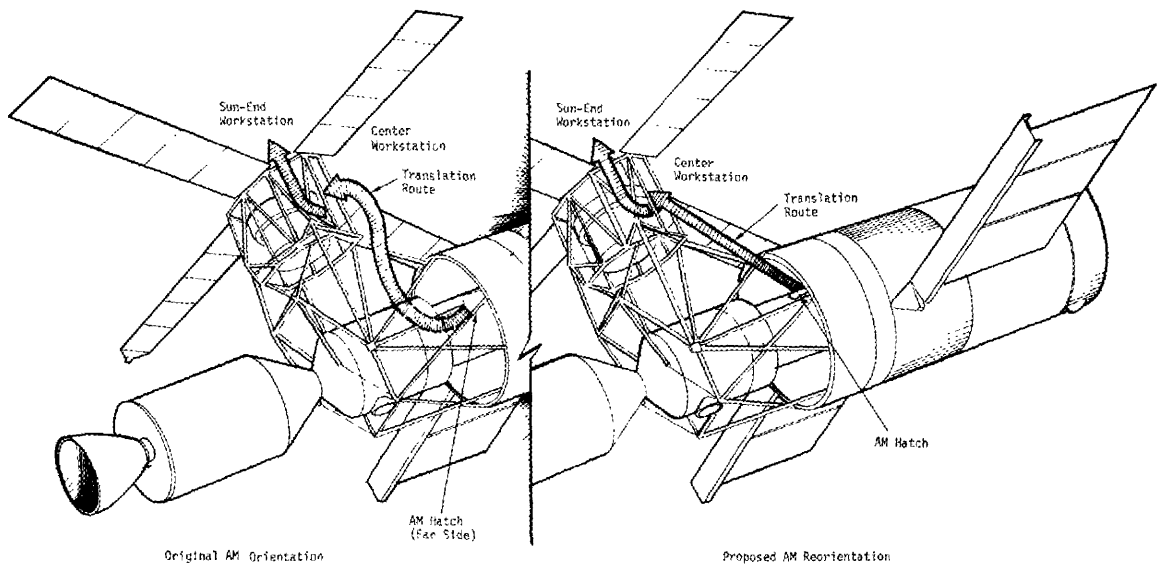

Figure 71. ATM Workstation and AM Hatch Orientation

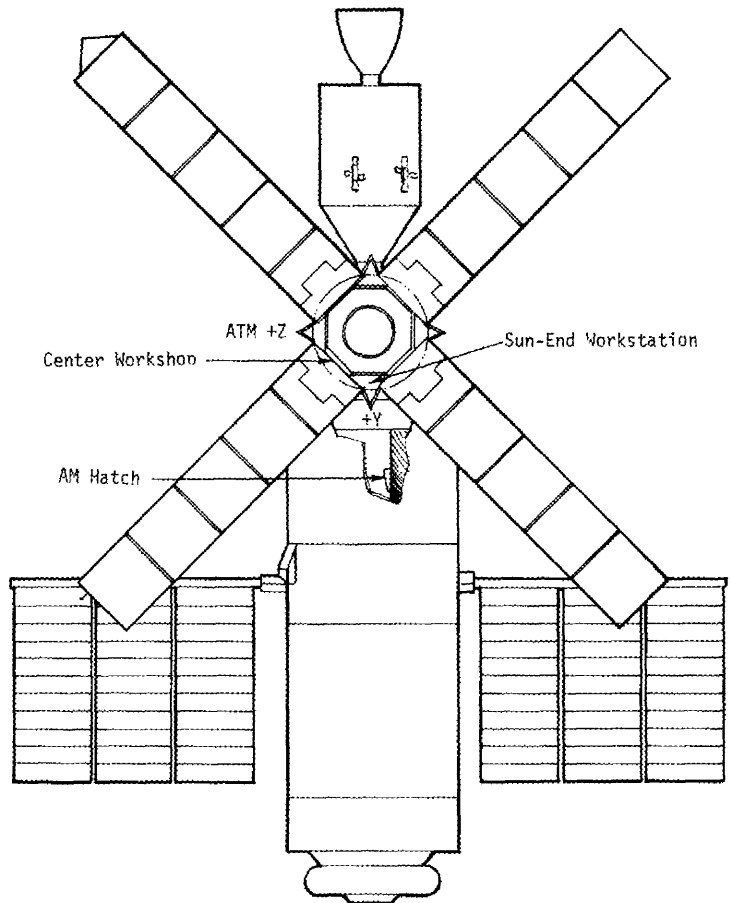

Figure 72. Skylab ATM Film Retrieval EVA Route

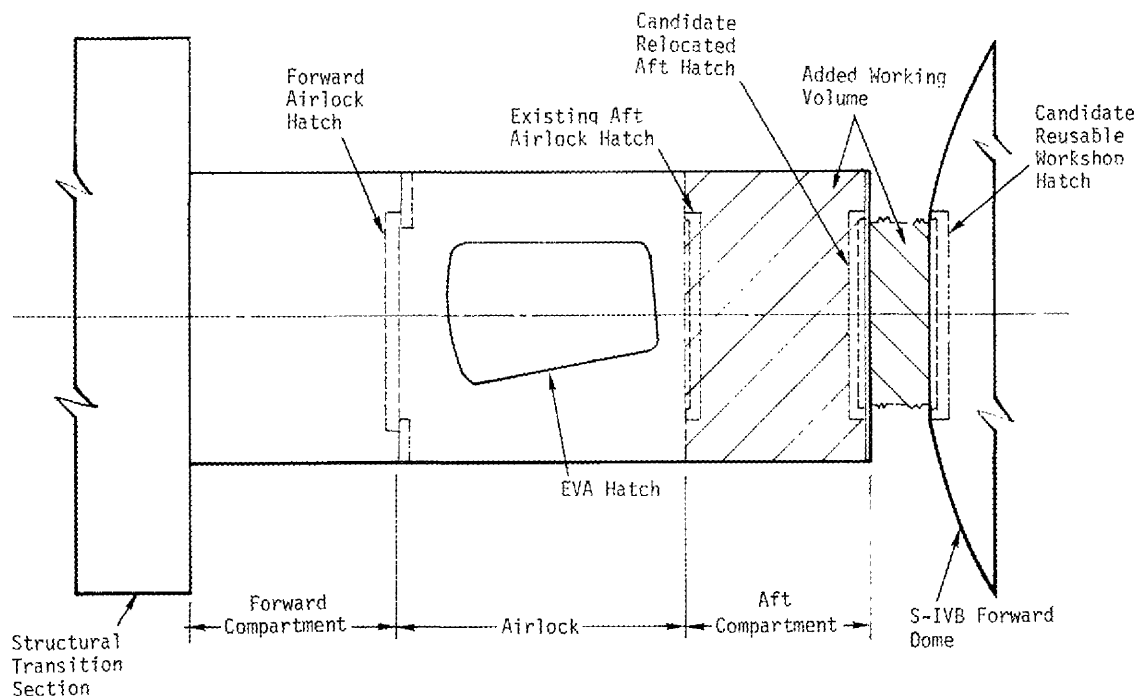

Figure 73. Proposed Methods of Expanding Airlock Working Volume

changes was deferred until evaluation of the airlock could be performed in zero-g and neutral buoyancy simulations to determine requirements for AM internal and external workstations. These preliminary investigations were conducted during October 1969 and showed that the airlock compartment was adequate for supporting the EVA without extending into the aft compartment. The tests also revealed that an external AM workstation would be required to fulfill the film magazine handling tasks, since this could not be accomplished with the second crewman standing up through the AM hatch. Although the aft compartment was not mandatory for EVA working volume, the additional space it provided was considered desirable. The workshop hatch was designed for reuse, but qualification tests to demonstrate this capability had not been planned. Because of the desirable extra volume it would provide at minimum expense and for other workshop considerations, the hatch was qualified to meet the operational requirements for EVA. The aft airlock hatch was also retained for possible contingencies during the Skylab mission.

With the resolution of these problems, attention turned to development of an AM exterior workstation in the Fixed Airlock Shroud area (FAS) and modification of the existing ATM workstations. The major emphasis, during development of the dry workshop film retrieval system, focused on methods for film magazine handling and transfer; therefore, the evolution of the workstations to achieve compatibility with candidate film transfer and translation concepts is presented in Section V.D. The following paragraphs discuss those changes unique to the basic ATM workstations

components, which were not dictated by film transfer considerations, and the establishment of the FAS workstation.

1. Fixed Airlock Shroud Workstation - Initial studies had considered mounting a foot restraint platform inside the tunnel where the second crewman could stand up through the AM hatch opening. With this concept the second crewman would perform all film package handling including removal from inside the AM and transfer of the film to the first crewman at the ATM workstations. Because of reach limitations both inside and outside the AM, the concept proved inadequate for use with the proposed film transfer equipment.

As a result, it was decided to concentrate on an exterior workstation, located near the AM hatch in the FAS area. The workstation would require mobility and stability aids mounted in a position to facilitate AM egress and film package handling. As envisioned, the workstation would provide equipment for the second crewman to perform a general management role for the film packages and umbilicals, while the first crewman translated to the ATM workstations and exchanged the film.

Umbilical clamps, which received much attention during the wet workshop era, were found to be unnecessary along the translation routes; consequently, only four clamps were provided. Two clamps, one for each crewman's umbilical, were placed just outside the AM hatch. In this position they would be accessible to the second crewman for the umbilical management task. The other two clamps were placed at the sun-end and center workstations, and ultimately became optional for the crewman's use at his discretion.

The necessity for a universal foot restraint to replace the Gemini-type dutch shoes and eliminate the "custom fit" requirement, was emphasized at a critical design review in March 1970. By the Fall of 1970, a new foot restraint concept, which could be used with a wide range of pressure suit boot sizes, was presented for evaluation (Figure 74). The new restraint's advantages were demonstrated during workstation development, and the device was incorporated in lieu of the dutch shoes. Since the layout of the FAS workstation components were dependent on film transfer methods, the concept development details are discussed in Section V.D.

2. Center Workstation - The basic design of this workstation had reached an advanced stage of development during the wet workshop era and required no major changes for use as the dry workshop center workstation. Analysis of dry workshop launch loads revealed that it was no longer necessary to launch the ATM with the diagonal strut in place. By the end of 1970, the strut with its ordnance release system was removed. This eliminated the concern for possible manual strut deployment and provided additional working space at the workstation. The universal foot restraints were installed on the work platform in place of the Gemini-type dutch shoes, and an umbilical clamp was provided for optional use by the crewman.

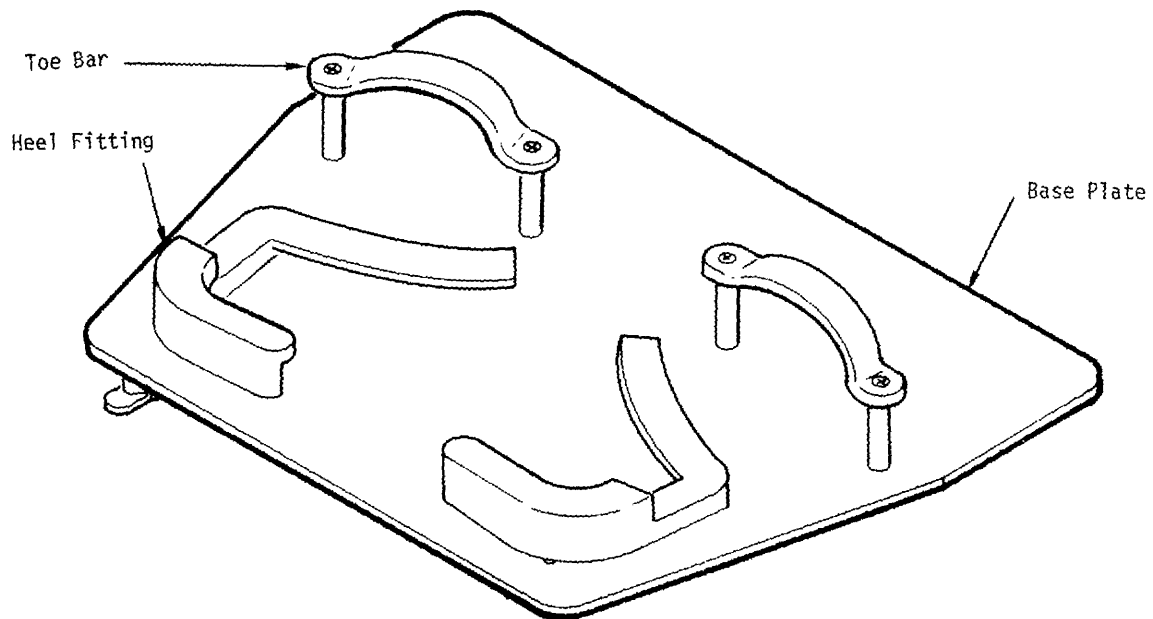

Figure 74. Universal Foot Restraint

Early in 1971, a sneak-circuit analysis was completed on the canister rotation control system, which showed that it was not possible for a stray signal to cause canister release or rotation during film retrieval. This allowed removal of the manually-operated mechanical gimbal lock. The rotation control panel incorporated the preferred handle-type controller with switches for opening the S082 aperture doors and status indicator lights (Figure 75). The hand controller provided two speeds in each rotation direction with ± 40 degrees of rotation and was compatible with pressure suit gloved-hand operation. A detent cam provided a tactile clue during transition from "LOW" to "HIGH" speeds. The "ROLL ENABLE/INHIBIT" switch activated a solenoid which disengaged a mechanical brake on the roll ring assembly in the "ENABLE" position. The "INHIBIT" position engaged the spring-loaded brake to restrain the canister from rotating. The protective shield, constructed of wire mesh, failed during vibration tests on the ATM and was replaced with a shield fabricated from a solid sheet of aluminum. Figure 76 illustrates the center workstation components in the final flight configuration on the mission support mockup. The additional structure shown is a platform for access to the mockup.

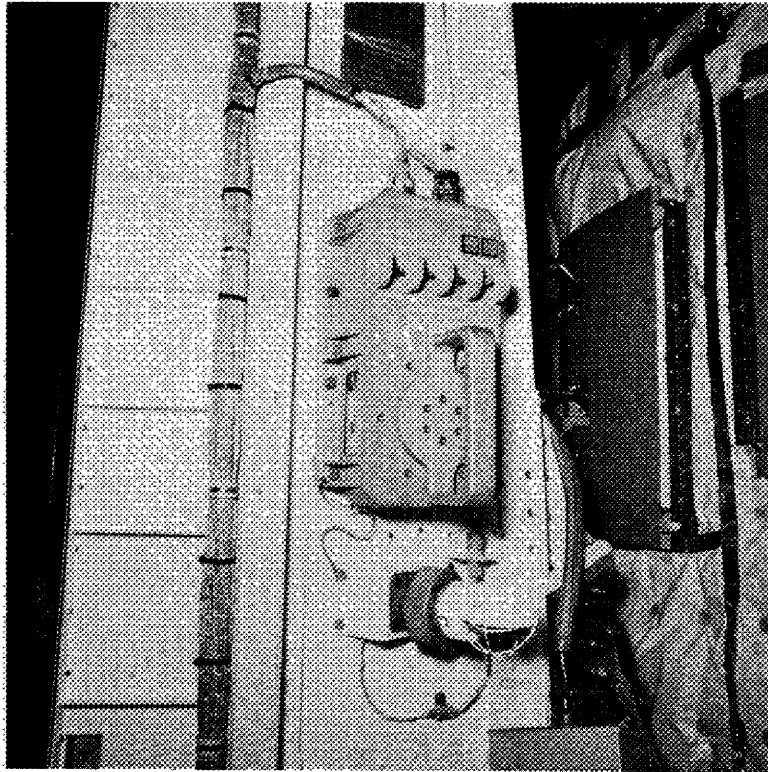

Figure 75. Canister Rotation Control Panel

3. Sun-End Workstation - The relocation of the sun-end workstation to obtain a better translation route for the dry workshop had no adverse effect on the basic concept. In fact, the greater clearance between the ATM sun-end and components of the launch vehicle allowed more flexibility in the workstation design. Because of canister roll limitations, the solar shield mounted foot restraint was moved to a position between the ATM +Y and -Z axes. However, the body position relationship to the canister mounted handrail and S082 access doors, as determined for the wet workshop, was retained (Figure 77). This foot restraint position would also facilitate film magazine handling and translation at the +Y axis. The canister rotation panel at the center workstation would be used to open the S082A and S082B aperture doors, providing clearance for the access doors, and for canister roll positioning. The universal foot restraint was incorporated and an umbilical clamp was added for use by the crewman at his discretion. The additional equipment installed at the workstation resulted from the film magazine handling and transfer requirements.



Figure 76. Center Workstation Configuration



Figure 77. Sun-End Workstation Configuration

D. Transfer and Translation Concepts

The conversion to a Saturn V-launched dry workshop had considerably greater effect on the crew translation and cargo transfer systems developed for the wet workshop than on the workstations. With egress from the AM and with the ATM oriented in the same manner as in the wet workshop concept, direct transfer and translation routes were not possible. The decision to relocate the sun-end workstation improved the route (Figure 72), but required a complete re-evaluation of the translation and transfer concepts. Another major problem involved finding suitable interior temporary stowage locations near the AM EVA hatch for the film magazines as discussed in Section V.C.

Three film magazine stowage concepts were investigated during the initial AM workstation development simulations in KC-135 zero-g flights (Figure 78). These simulations were used to evaluate the adequacy of the

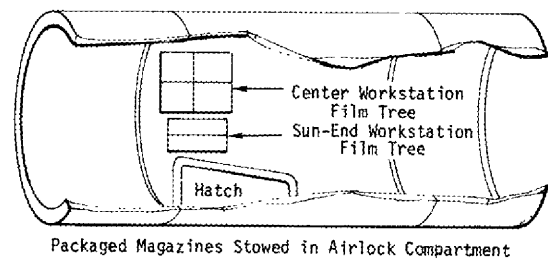
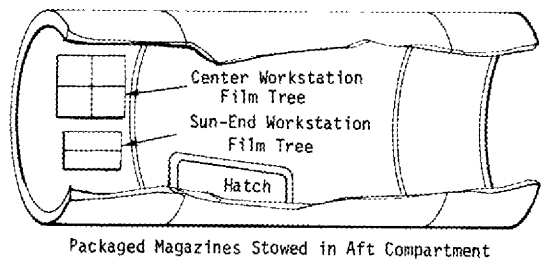
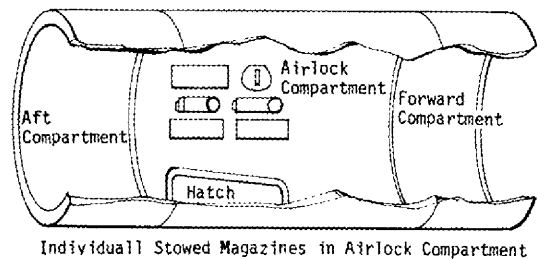

Figure 78. AM Film Magazine Stowage Concepts

airlock compartment to support the handling of either film tree packages or individual film magazines. One concept considered stowing the film magazines individually within the airlock compartment. In another concept, the sun-end and center workstation magazines were stowed on separate film trees within the AM aft compartment. This concept would determine the feasibility of using the additional volume of the aft compartment. A third concept consisted of the film tree package arrangement stowed in the airlock compartment. The final orientation relative to the EVA hatch would be determined from further studies.

Results of the simulation showed that use of the aft compartment was not essential for film magazine stowage, but did provide a desirable increase in working space for the two crewmen. Magazine handling and transfer was satisfactory with all three concepts, and no difficulties were encountered with the film tree package.

Concurrent with the AM interior stowage investigations, preliminary concepts for transporting the crewman and cargo from the AM hatch area to the ATM workstations were developed. These concepts, which included adaptations of the devices developed for the wet workshop, are identified and summarized in Table 1 and are illustrated in Figure 79. The alternative of the crewman carrying the film magazines one at a time, was considered and rejected because of the higher probability of damage to the magazines and the increased translational workload required.

Table 1. Dry Workshop Film Transfer and Translation Concepts

AM to ATM Workstation	Film Transfer Concept	Film Package Capability	Translation Concept
Sun-end Concept	Unirail Skateboard-Manually Propelled	Multiple-Two Magazines on Filmtree	Dual Rail System
Center Concept A	Endless Clothesline - Manually Actuated from AM Exterior	Single Magazine	Dual Rail System to ATM Rack With Lateral Transfer to Center Workstation Handrails
Concept B	Same as above	Multiple-Four Magazines on Film Tree	
Concept C	Flip-over Device Manually Actuated from AM Exterior	Single or Multiple With Film Tree	
Concept D	Extendible Boom-Electrically driven With Manual Backup	Single Magazine	

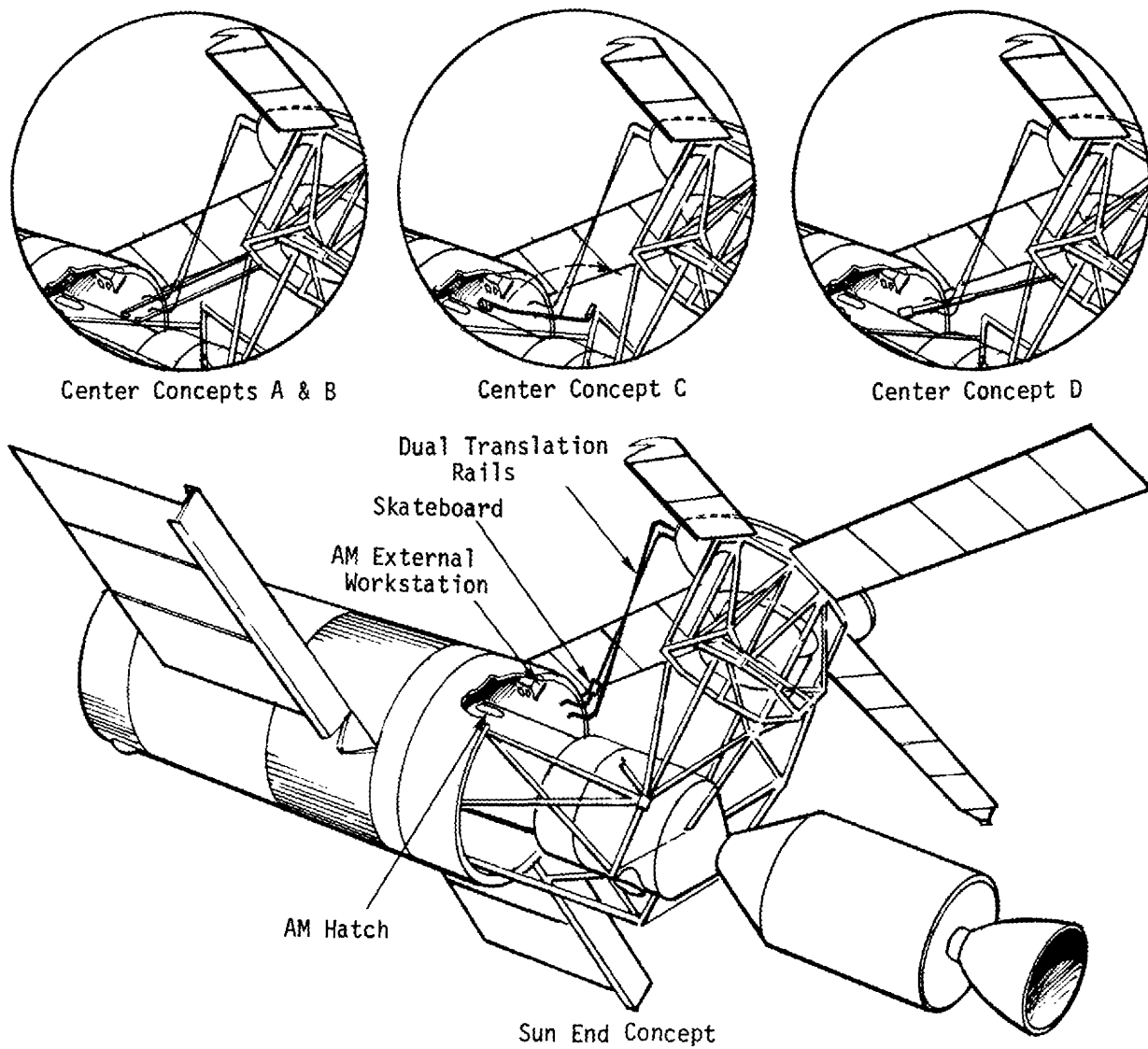

Figure 79. Dry Workshop Film Transfer and Translation Concepts

The endless "Brooklyn Clothesline" device was suggested during the crew station review and was based on a cargo transfer device used during the Apollo lunar landing missions. The clothesline was not considered for sun-end film transfer in these early concepts because it was felt that too many lines would create a management problem. The extendible boom devices, which were considered during the early wet workshop studies, again became a potential method of film transfer. During evaluation of the concepts, the flip-over device, or concept C, was dropped and development was concentrated on the remaining methods of film transfer.

By late 1969, the AM external or FAS workstation had evolved through one-g and neutral buoyancy simulations to the configuration shown in Figure 80. The foot restraints, handrails and a "belly bar" were located to facilitate the handling and transfer of the film magazines from the AM interior to the ATM workstations with the proposed transfer devices. Two temporary stowage positions were evaluated: one attached to the belly bar and one located on the AM tunnel surface. The skateboard had been changed from the unirail concept to a dual roller system attached to both of the parallel translation rails. As the simulations progressed with this configuration, the AM surface mounted stowage position was eliminated because

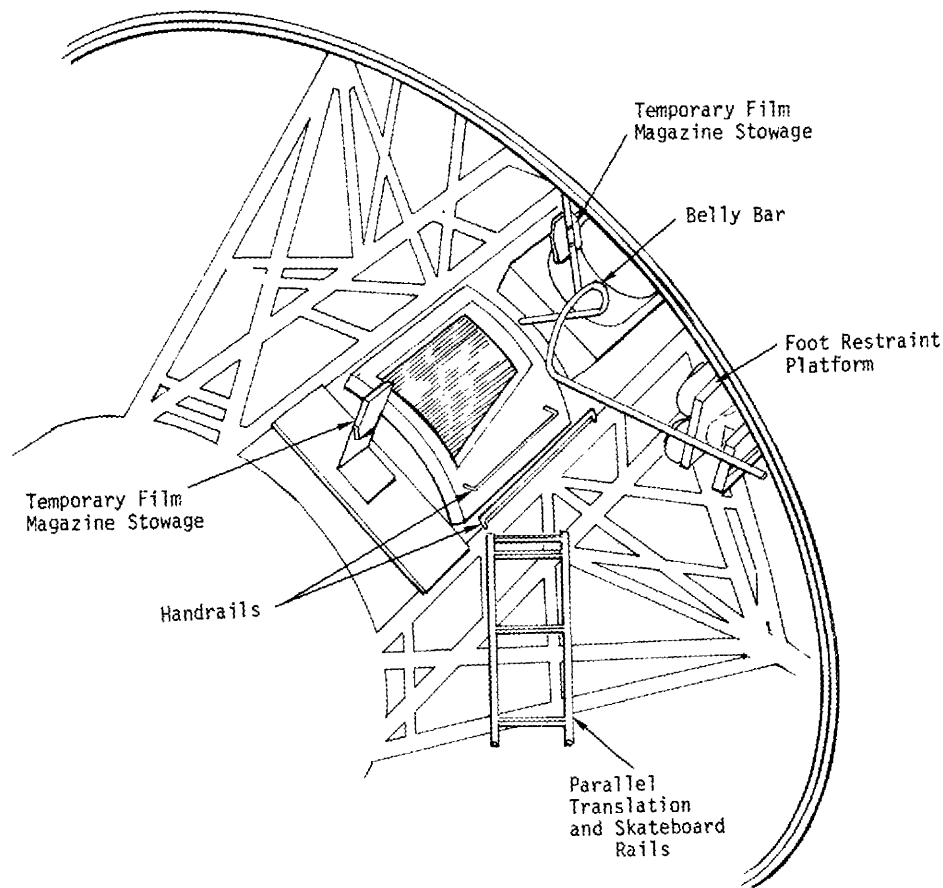
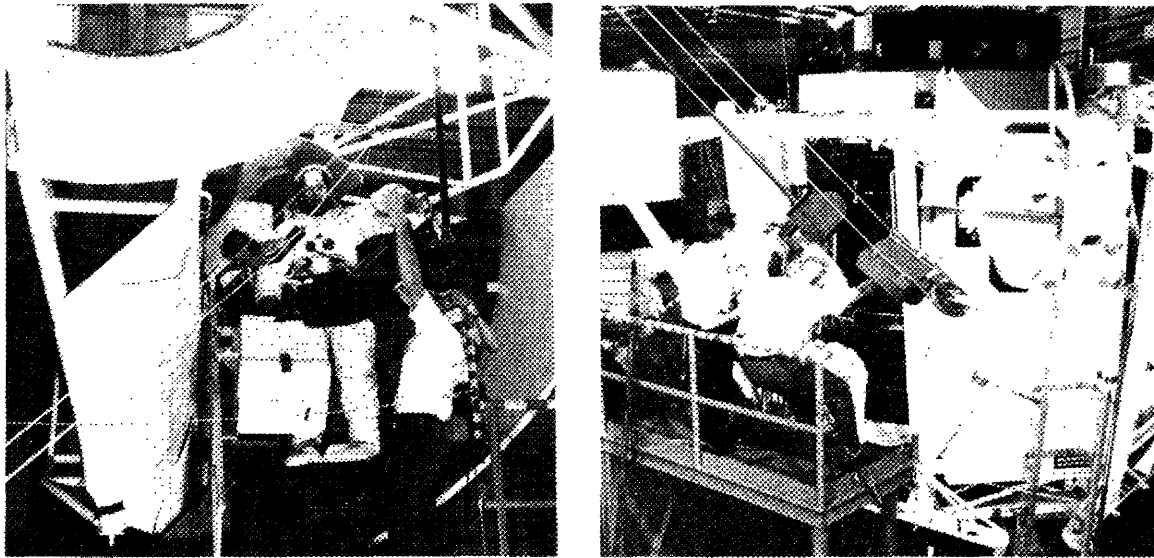

Figure 80. AM External or FAS Workstation Concept

of interference with the clothesline. The belly bar, which was intended to serve as a stability aid for the crewman as he entered the foot restraints, was also removed when it was found that the temporary film stowage provision could be used for the same purpose. Figure 81 shows the one-g workstation mockups used to evaluate the prototype film transfer concepts.



FAS Workstation

Center Workstation

Figure 81. Prototype Extendible Boom and Clothesline Evaluation

During these tests it became obvious that the dual rail translation and film transfer concept created an additional workload for the crew. It required installation of a section of the dual rail system across the MDA and ATM interface before the film retrieval EVA task could begin. Because of the alignment difficulties which would be involved in deploying a continuous rail system, the concept was dropped. The dual rail section mounted on the ATM was retained for translation and skateboard film transfer between the center and sun-end workstations. A single handrail system was developed for translation from the FAS, across the deployment assembly, to the ATM rack structure.

By February 1970, two alternate film transfer concepts had evolved for each of the ATM workstations. Either the clothesline or an extendible boom mounted at the FAS workstation could be aimed directly at the center workstation. Another clothesline would be used for the sun-end film magazines. Because there was no direct line-of-sight to the sun-end workstation, a second foot restraint was required to receive and temporarily the magazines at the sun end (Figure 82). Either a second boom or an

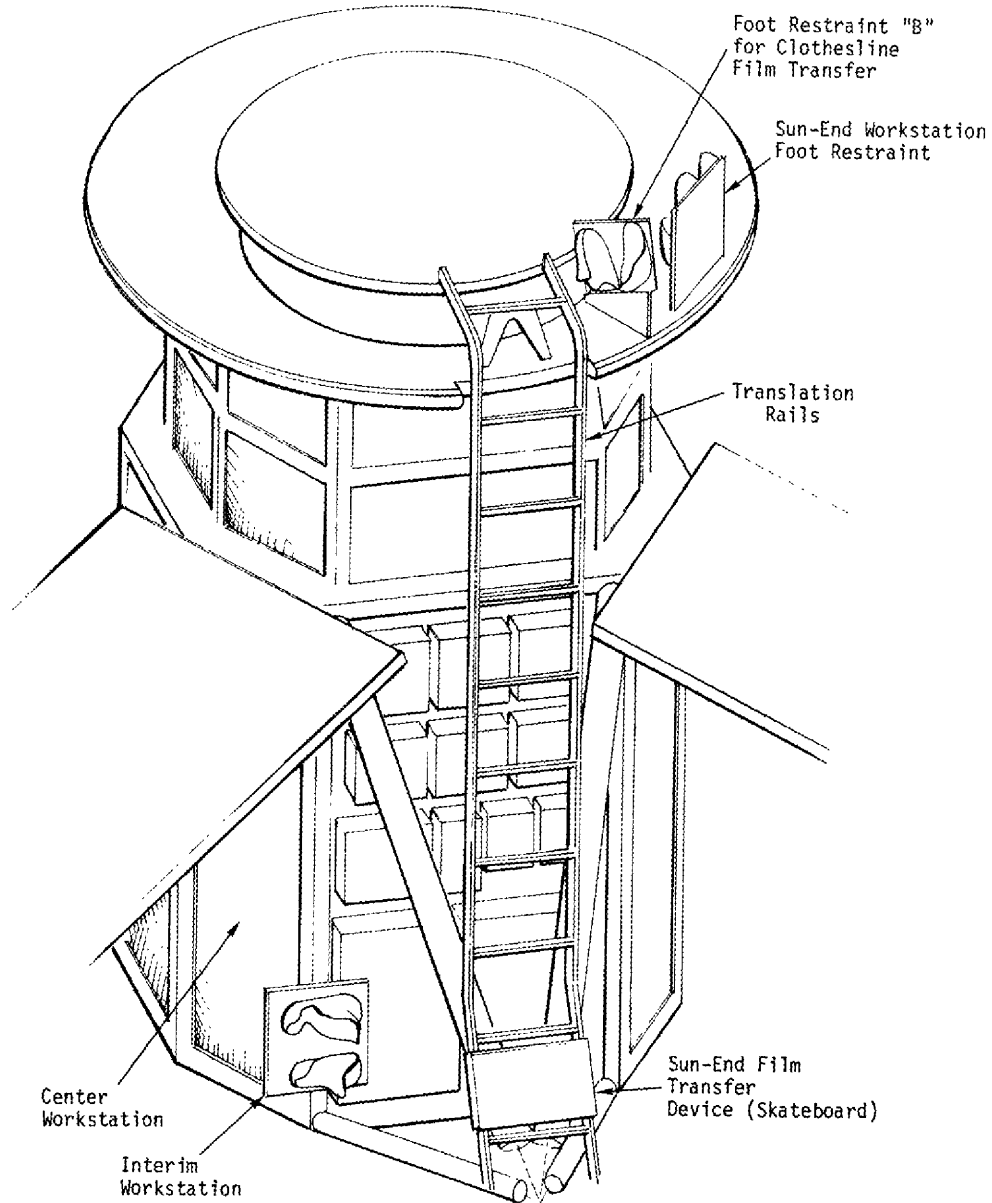

Figure 82. Sun-End Film Transfer Concepts

adjusted center workstation boom would be used to transport the magazines to an "interim workstation" for transfer to the skateboard. The crewman would then propel the skateboard as he translated from the interim workstation to the sun-end. Since interim film transfer with the skateboard required additional magazine handling and crew workload, studies were initiated to determine a location in the FAS for the extendible boom, which would allow a more direct transfer to the sun end. When these studies proved the feasibility of using a boom, the skateboard was eliminated.

Additional evaluation tests of the clothesline and extendible boom demonstrated the capability of transferring the film magazines in single packages attached to the center and sun-end film trees. As the tests continued, it was determined that part-task simulations would not allow the selection of a preferred film transfer device. Plans were then made to conduct an evaluation, with astronaut participation, of the entire film retrieval system in an integrated test. This was accomplished in the neutral buoyancy simulator from March 4 to 11, 1970.

The integrated test resulted in the selection of an extendible boom as the primary film magazine transfer device with the clothesline as a secondary or backup device. Two booms and two clotheslines would be used, one of each for the center workstation and for the sun end. The booms would be hard-latch mounted to allow interchange using one hand. A spare boom was recommended for incorporation at the FAS workstation in the event of failure.

The proposed changes at the sun end to accommodate the boom included a new interim workstation near area "A", as shown in Figure 83. This

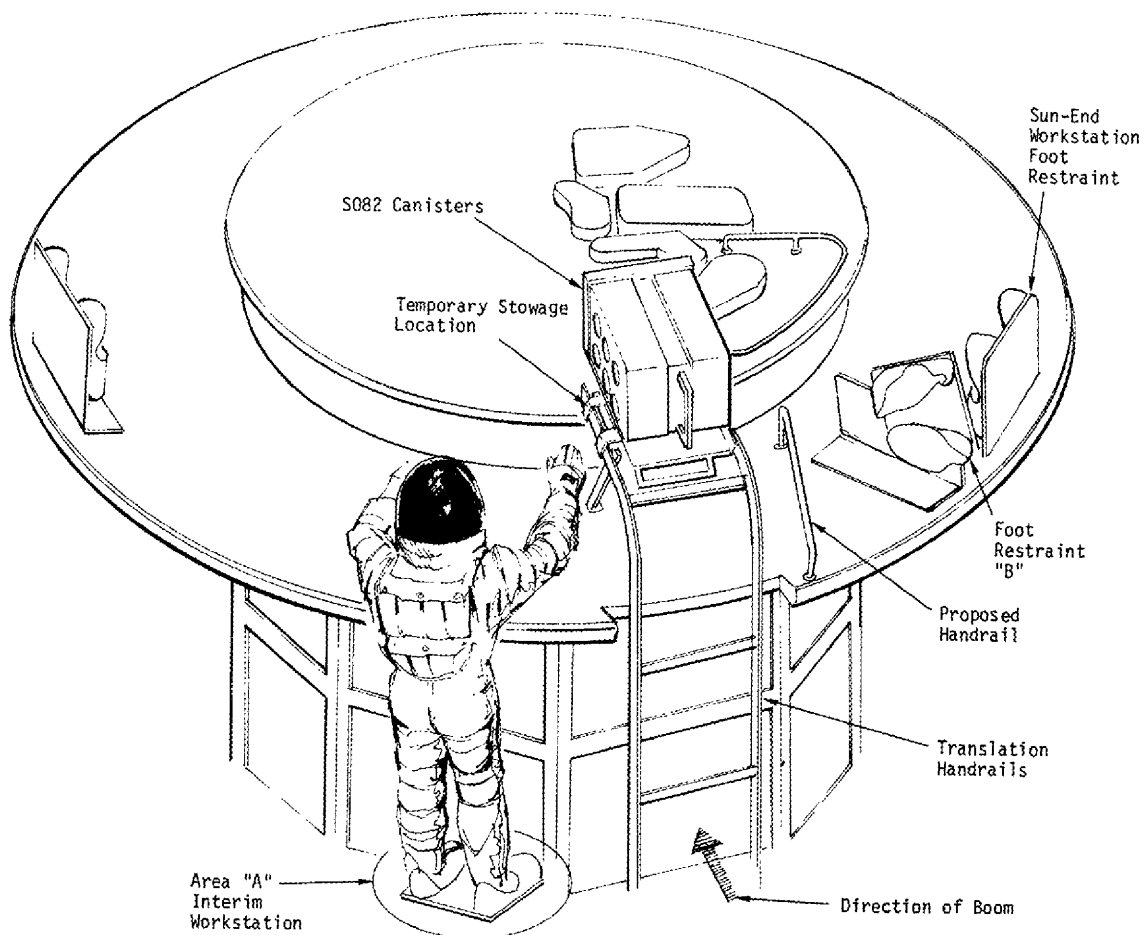

Figure 83. Proposed Sun End Changes for the Extendible Boom Film Transfer Concept

would allow the crewman to transfer the magazines from either the boom or clothesline to the temporary stowage position and eliminate the necessity for foot restraint "B". The dual translation rails to the sun end were retained, and a new handrail was proposed to facilitate translation across the solar shield into the sun-end workstation foot restraint. It was also recommended that a hard-latch interface for magazine attachment to the boom be designed to preclude the possibility of loss or damage to the magazines.

After selection of the primary and backup film transfer devices, work began to incorporate the necessary workstation changes for an ATM critical design review. The FAS workstation changes are shown in Figure 84. Positions for the two booms had been determined, and the handrails and foot restraints were located for operation of the devices. The clothesline attachment locations were designed to approximate the travel path of the booms as closely as possible. This took advantage of the previous work done in positioning the booms for access to the film magazines at both the airlock and ATM transfer points. At the center workstation, the translation handrail configuration was altered to provide

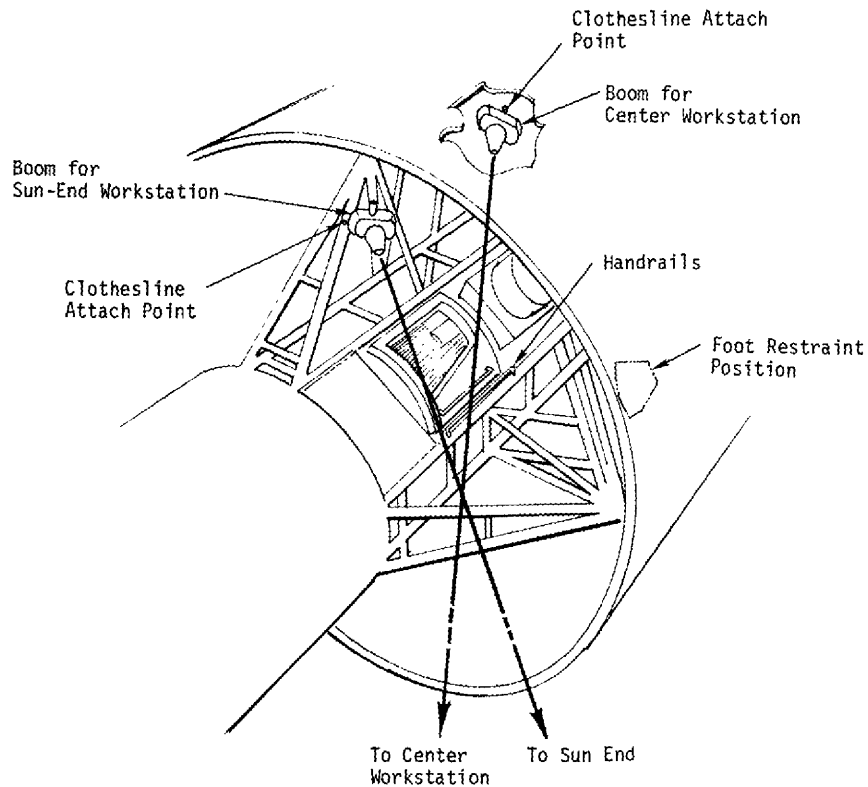

Figure 84. FAS Workstation Arrangement for Film Transfer Devices

easier entry into the workstation, and the clothesline attach point was established (Figure 85). The interim workstation, required for transferring the film magazines from the boom or clothesline to the sun end, was

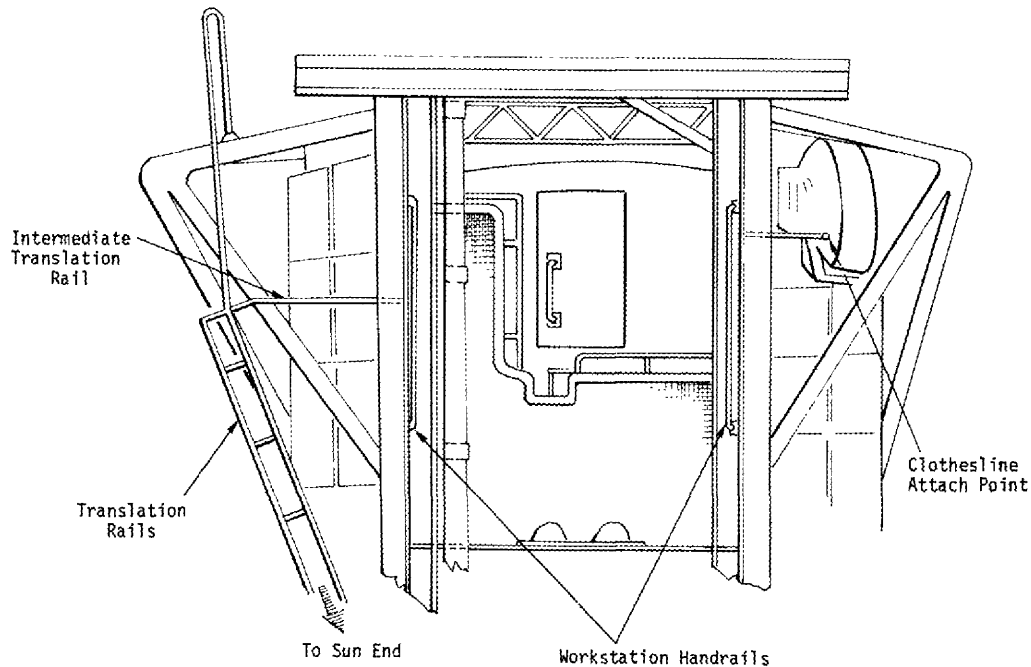

Figure 85. Center Workstation Mobility Aids and Film Transfer Provisions

located in neutral buoyancy simulations, and was renamed the "transfer workstation" (Figure 86). The translation rails and handrail were positioned to assist the crewman in transferring from the transfer workstation into the sun-end workstation. To accommodate the crewman's reach limitations, the sun-end film tree receptacle and a temporary film magazine stowage container were located symmetrically on either side of the foot restraint position. The temporary stowage container was required to secure the unexposed magazines while the exposed magazines were removed from the experiment and placed in the S082 canisters.

The basic EVA system concept was presented at the ATM Critical Design Review in May 1970. At the conclusion of the review, it was recommended that work proceed toward final development of the flight design. During the following months, the hardware components of the system were developed on one-g mockups and verified in neutral buoyancy simulations. Lighting studies were initiated to provide adequate illumination along the translation routes and at the workstations. The film transfer boom was designed for interchangeable mounting in the FAS

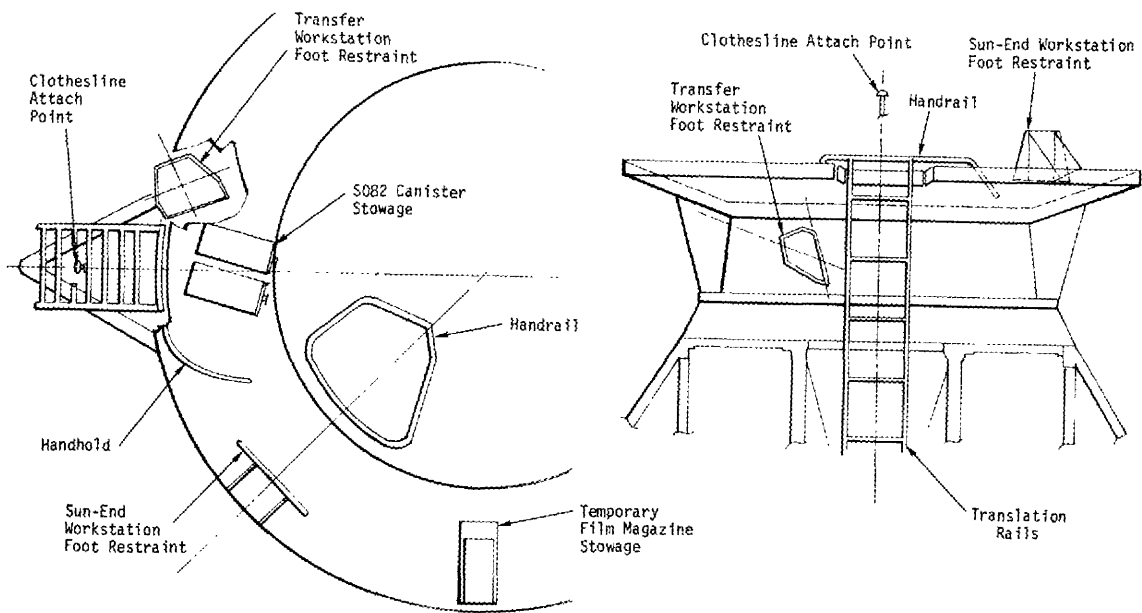

Figure 86. Transfer and Sun-End Workstation Arrangement

EVA bay and incorporated a latching hook for film magazine attachment (Figure 87). In operation the sun-end film magazines, within their protective canisters, would be transported as a single package on the film tree. The center workstation magazines would be transferred as a

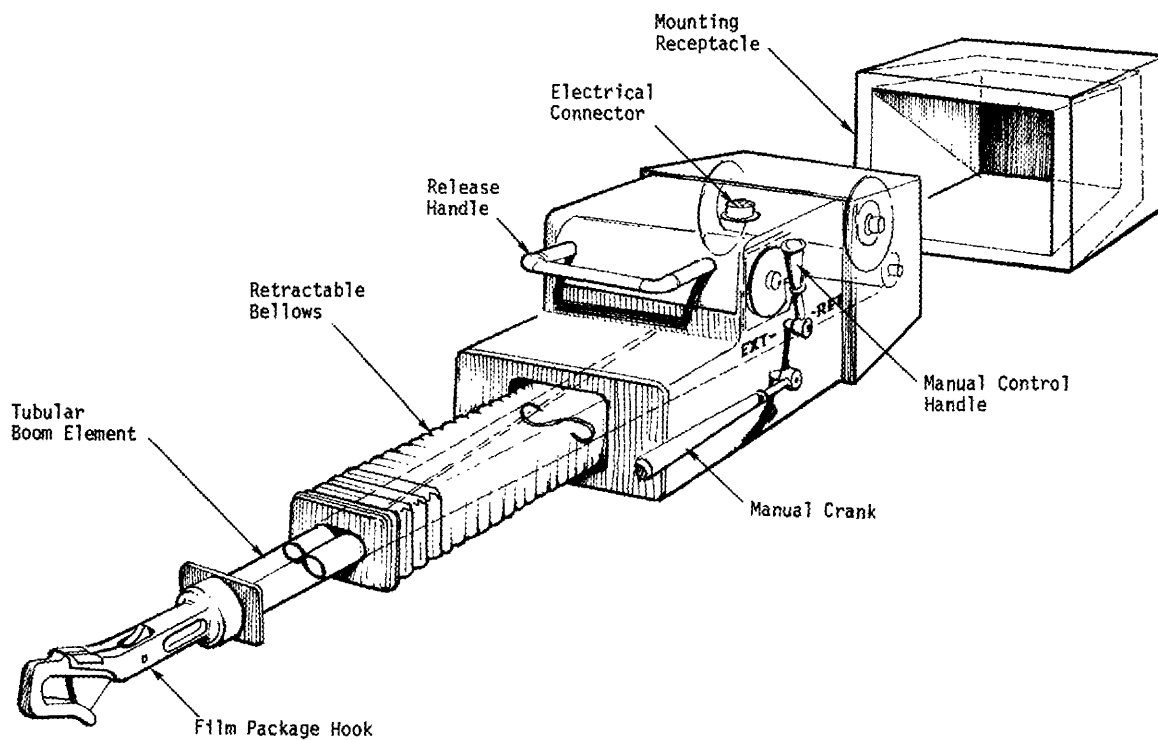
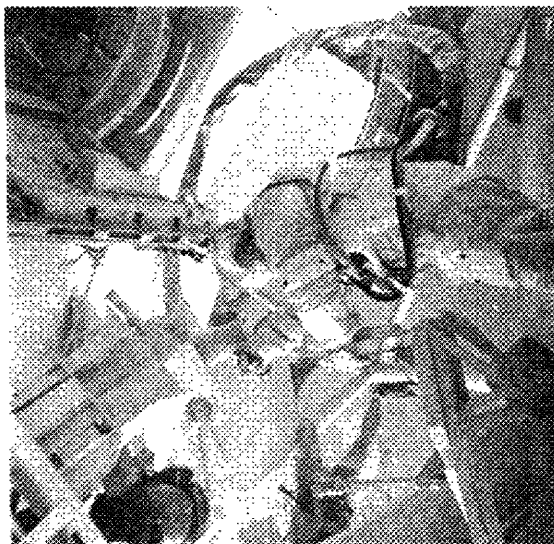

Figure 87. Film Transfer Boom and Hook

film tree package from the AM and transported individually to the workstation. The boom hook was designed to latch to the sun-end film tree or to the center film magazine handles.

Receptacles for the film trees and film transfer boom were located within the crewman's reach at the FAS workstation. These positions were verified during neutral buoyancy simulations along with placement of the boom control panel (Figure 88). A spare film transfer boom and mounting receptacle was provided adjacent to the center workstation boom.



Sun-End Film Tree

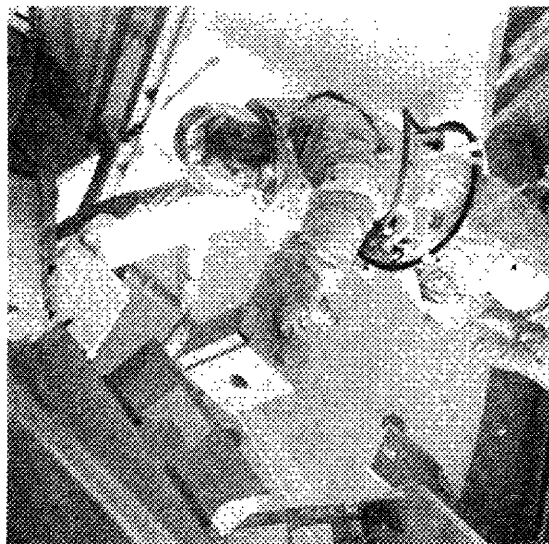

Film Transfer Boom

Figure 88. Film Transfer Boom and Film Tree Receptacle Location Evaluation During Neutral Buoyancy Test

The ATM sun end design incorporated a two-part folding boom mounted on the solar shield for clothesline attachment (Figure 89). A receptacle for the S082 canister film tree was positioned for access from the transfer workstation foot restraints during film transfer and from the sun-end workstation foot restraints during film magazine replacement. The temporary film magazine stowage container was a box-like design mounted to the right of the workstation on the solar shield. The translation rail and handrail arrangement required only minor changes for the sun-end component locations.

A Critical Design Review was conducted between November 16 and 20, 1970, to evaluate the total Skylab EVA system. In addition to one-g and neutral buoyancy simulations of the film retrieval operations, an evaluation was performed to determine the adequacy of the EVA lighting provisions. The preliminary lighting requirements, which had been developed earlier in the year, resulted in some studies and lighting tests. These tests defined the placement, orientation and illumination levels of the EVA lights. The lighting system was accepted during the review with only minor changes.

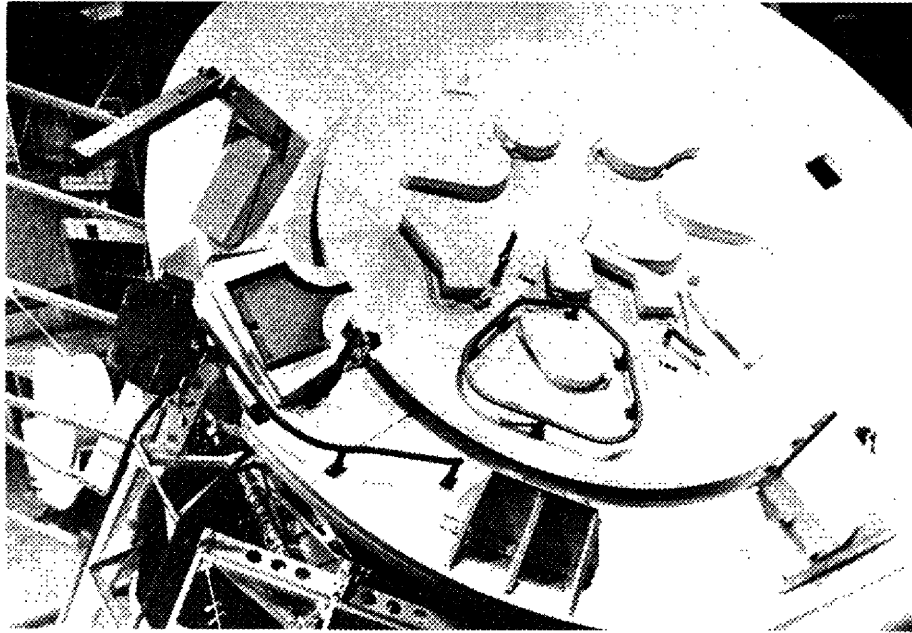
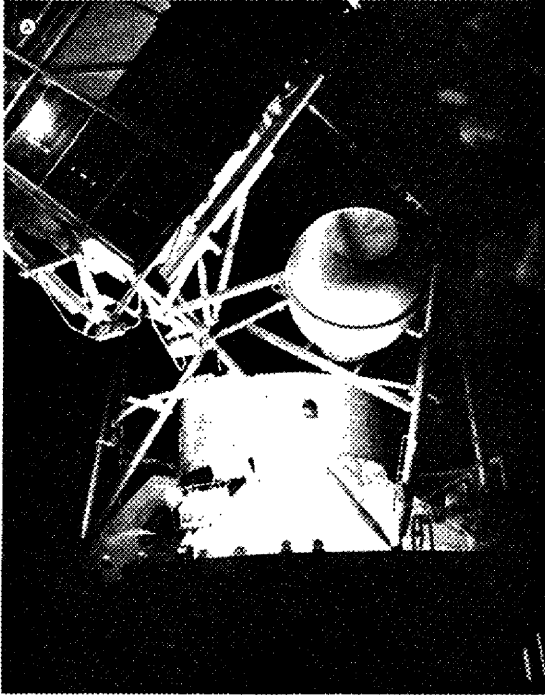

Figure 89. ATM Sun End Film Retrieval Components

Anti-glare shields were added to some of the EVA lights to prevent crew discomfort and possible performance degradation. Photographs of the lighting evaluation are presented in Figure 90. The spherical shaped object, attached to the deployment assembly structure, was a D021 expandable airlock experiment which was later deleted from Skylab.

The EVA system was accepted during the Critical Design Review with little modification, and effort concentrated on final flight hardware design and crew training for the Skylab mission. Because of the consistent flight crew participation during development, minimal procedural changes occurred during training. The review had identified a need for a temporary workstation in the FAS to aid in the replacement of a failed film transfer boom. As a result, the replacement workstation was developed. This consisted of a handrail and a small section of aluminum channel, mounted near the airlock tunnel, which served as a toe bar and heel restraint. In this position, all three of the film transfer booms could be reached and exchanged.

Verification and interface testing continued through 1971 and 1972 as the flight configuration hardware became available. The film transfer boom hook was redesigned to make attachment and detachment to the film magazine handles easier. The new hook secured the magazine or sun-end film tree handle with a locking mechanism that exerted a constant force (Figure 91). It was determined from vibration testing that the end plate on the film transfer boom was unable to withstand launch loads with the



EVA Route

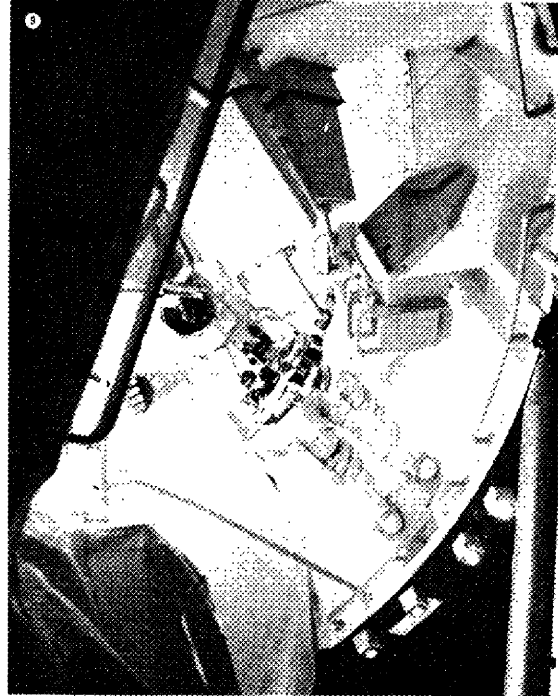

FAS Workstation

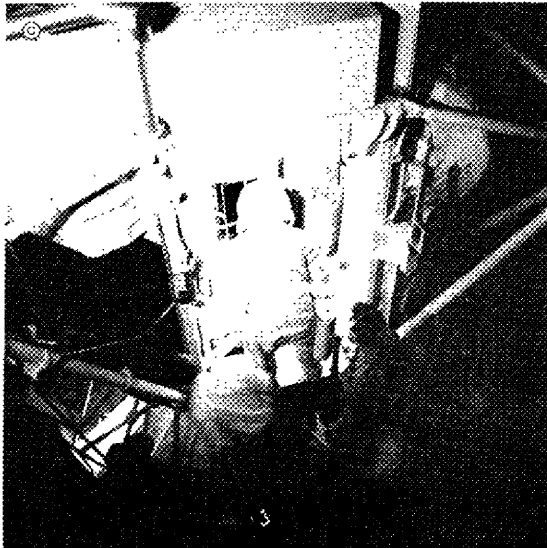

Center Workstation

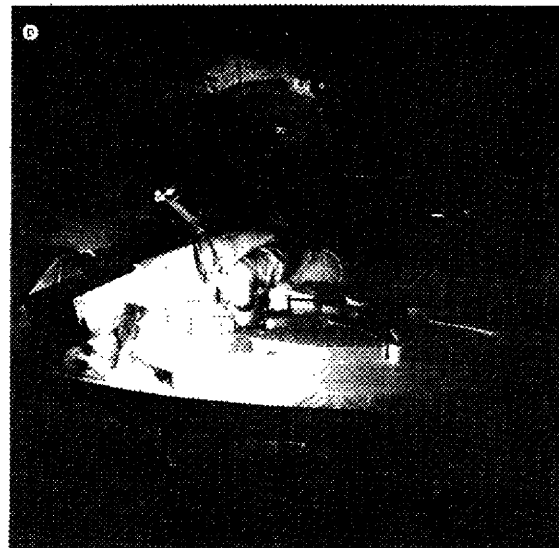

Sun-End Workstation

Figure 90. EVA Lighting Evaluation

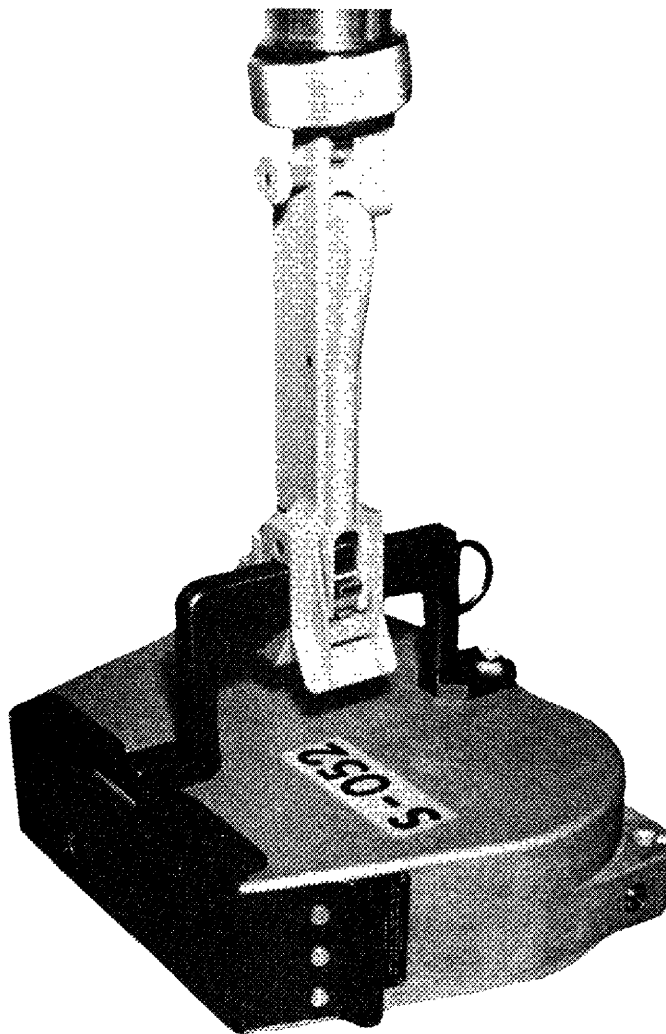

Figure 91. Film Transfer Boom Hook

hook installed. To correct the problem, a quick-disconnect was added to the boom and hook so that the hooks could be stowed for launch and installed during the first EVA. A stowage box for the hooks was added in the FAS area.

Additional illumination tests were conducted early in 1972, to determine the visual effects of solar lighting on the ATM sun end nomenclature. The tests also considered crew visibility problems resulting from the contrast between the highly reflective canister surface and the

low reflectance inside the access doors and film magazine receptacles. The tests were performed on the one-g mockup, which had been painted to simulate the color scheme and reflectivities of flight coatings, using a 0.7 solar constant (Figure 92). No difficulty was encountered with the crewman's ability to see inside the canister or read labeling while retrieving the magazines.

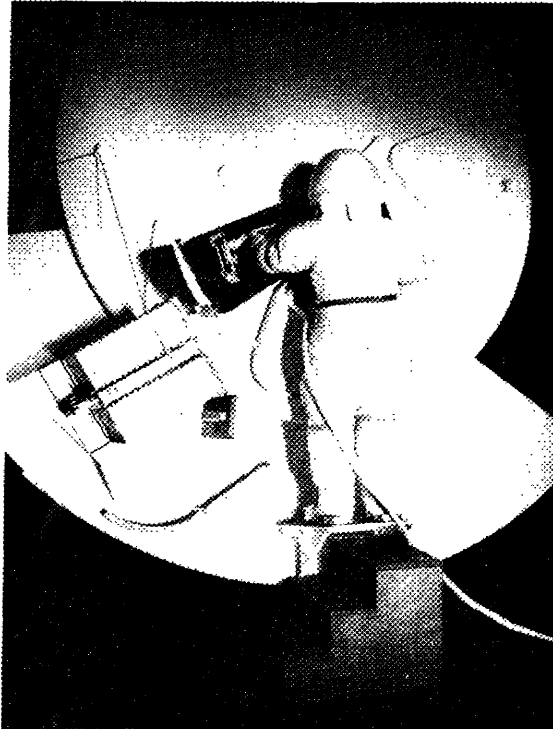

Figure 92. Solar Illumination Study

An ATM Crew Compartment Fit and Function review was conducted during April and May 1972, to verify ATM hardware operation and the crewman interface with the EVA equipment. Figures 93 through 96 illustrate typical interface verification performed during the review and indicate details of the EVA film transfer equipment. The four flexible tabs on the sun-end temporary stowage container restrained the magazine during film exchange (Figure 96). This major interface review was successfully accomplished and provided a final confirmation of the flight equipment for launch.

The remainder of 1972 was devoted to intensive flight crew training in the neutral buoyancy simulator. The final detailed film retrieval task procedures were developed for the mission, and small refinements were made to enhance the crewman and equipment interfaces. Figures 97 through 102 show the configuration of the EVA system and depict the EVA operations performed during film retrieval with the film transfer booms.

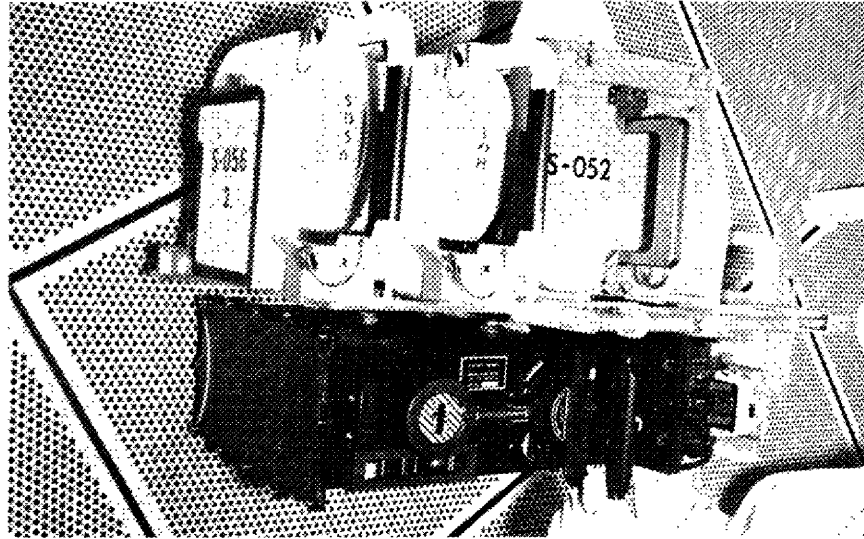

Figure 93. Center Workstation Film Tree

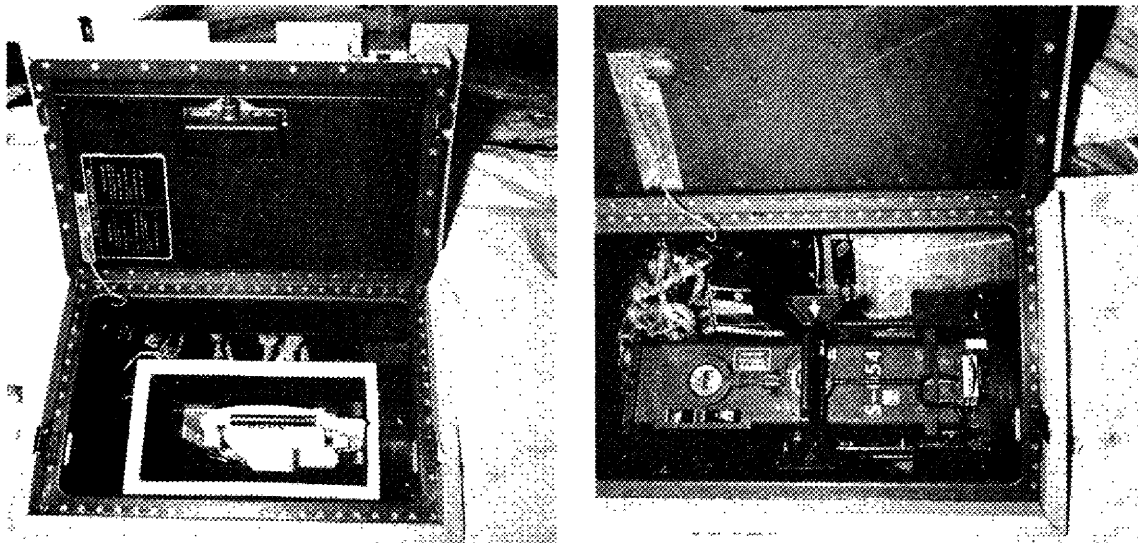

Figure 94. Typical Center Workstation Access Doors With Film Magazine Installed

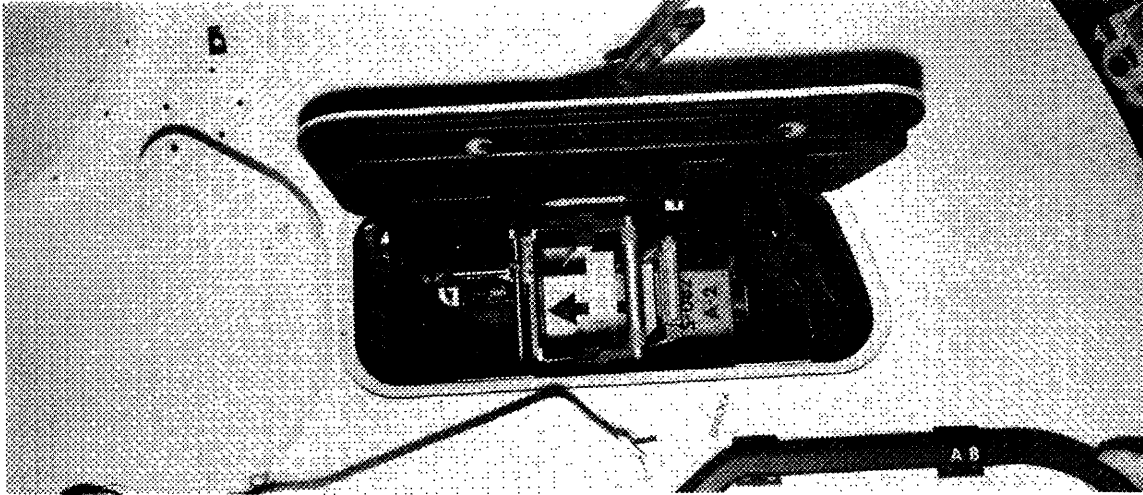

Figure 95. Sun-End Access Door With Film Magazine Installed

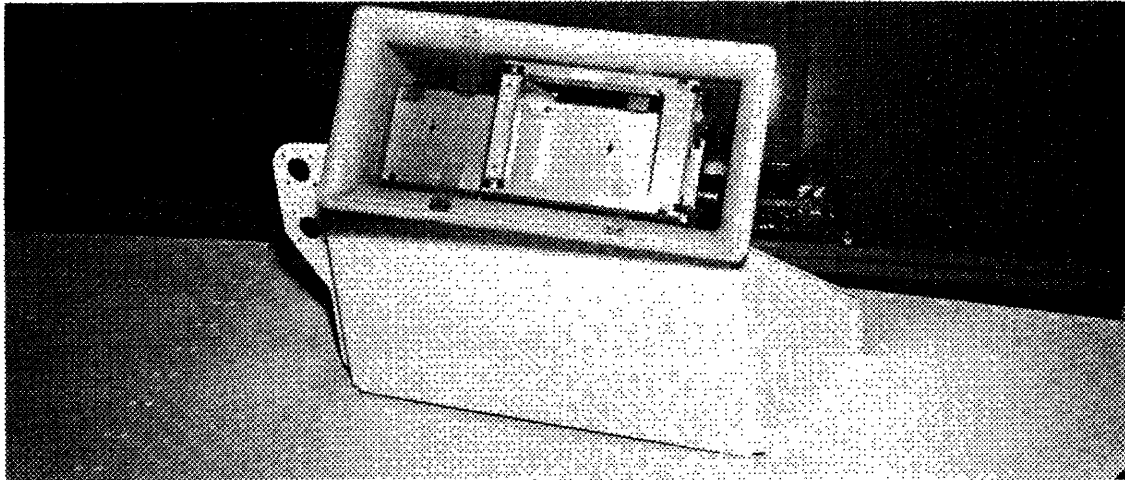

Figure 96. S082 Film Magazine in Sun-End Temporary Stowage Container

The clothesline assemblies, shown in Figure 103, were stowed in containers at the side of the film transfer booms. One end of each clothesline was attached to a ring at the boom receptacle before launch. If deployment of the clotheslines was required, the crewman had only to translate with the free end to the ATM workstation. The film retrieval operations unique to the clothesline method of film transfer are illustrated in Figures 104 through 107.

By the end of 1972, the crew training was essentially complete, and the flight hardware was being assembled for the Skylab launch. Contingency studies were performed to determine system failures which could prevent ATM

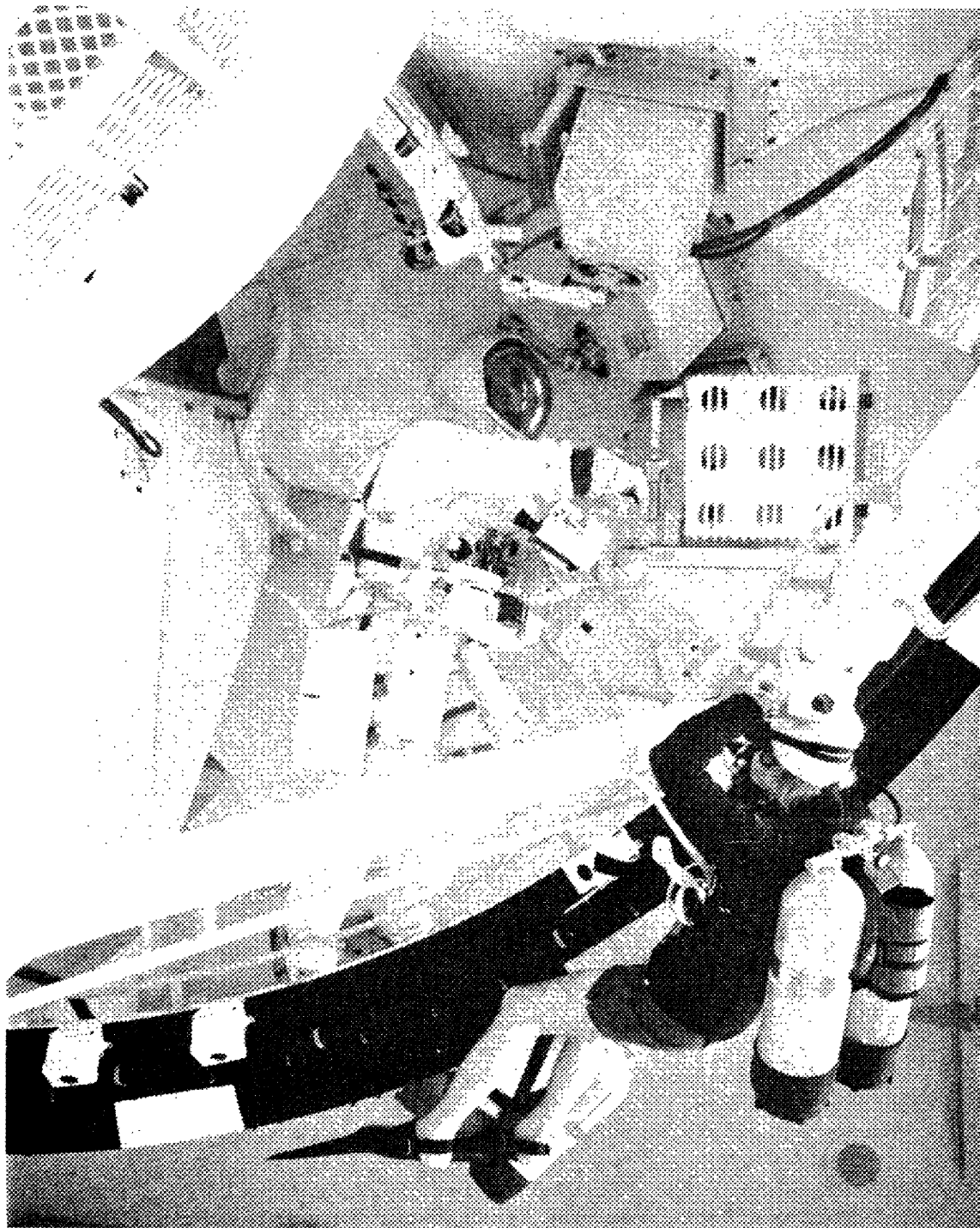

Figure 97. View of FAS workstation with crewman placing 16mm camera, used to photograph the EVA operations, in a stowage position adjacent to the sun-end film tree. The film transfer boom hooks are installed on the booms and folded to the standby position. At the crewman's right are the boom control panel and a temporary magazine stowage hook.

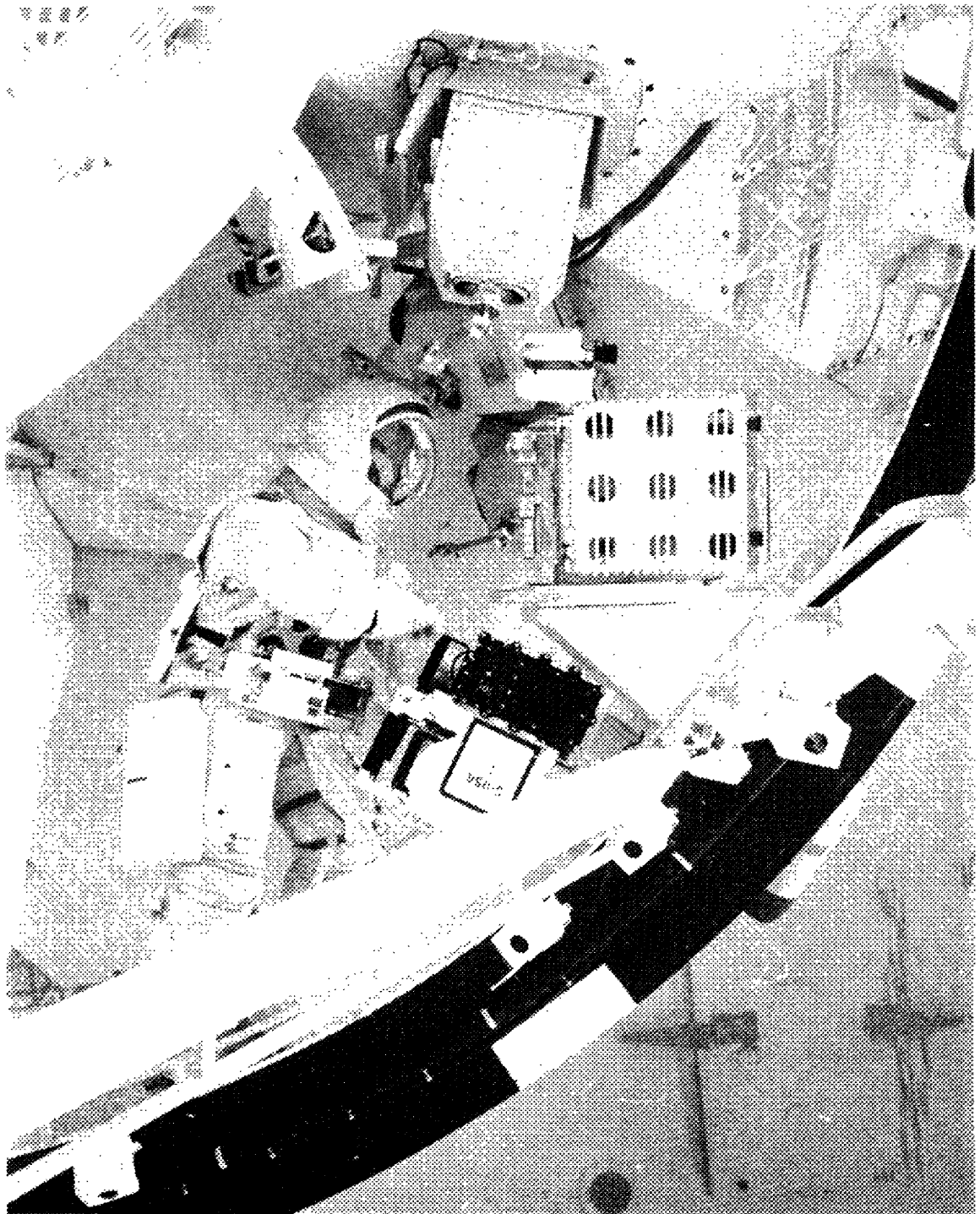

Figure 98. Crewman transferring center workstation film tree to temporary stowage receptacle. The 16mm camera is shown in a temporary stowage position.

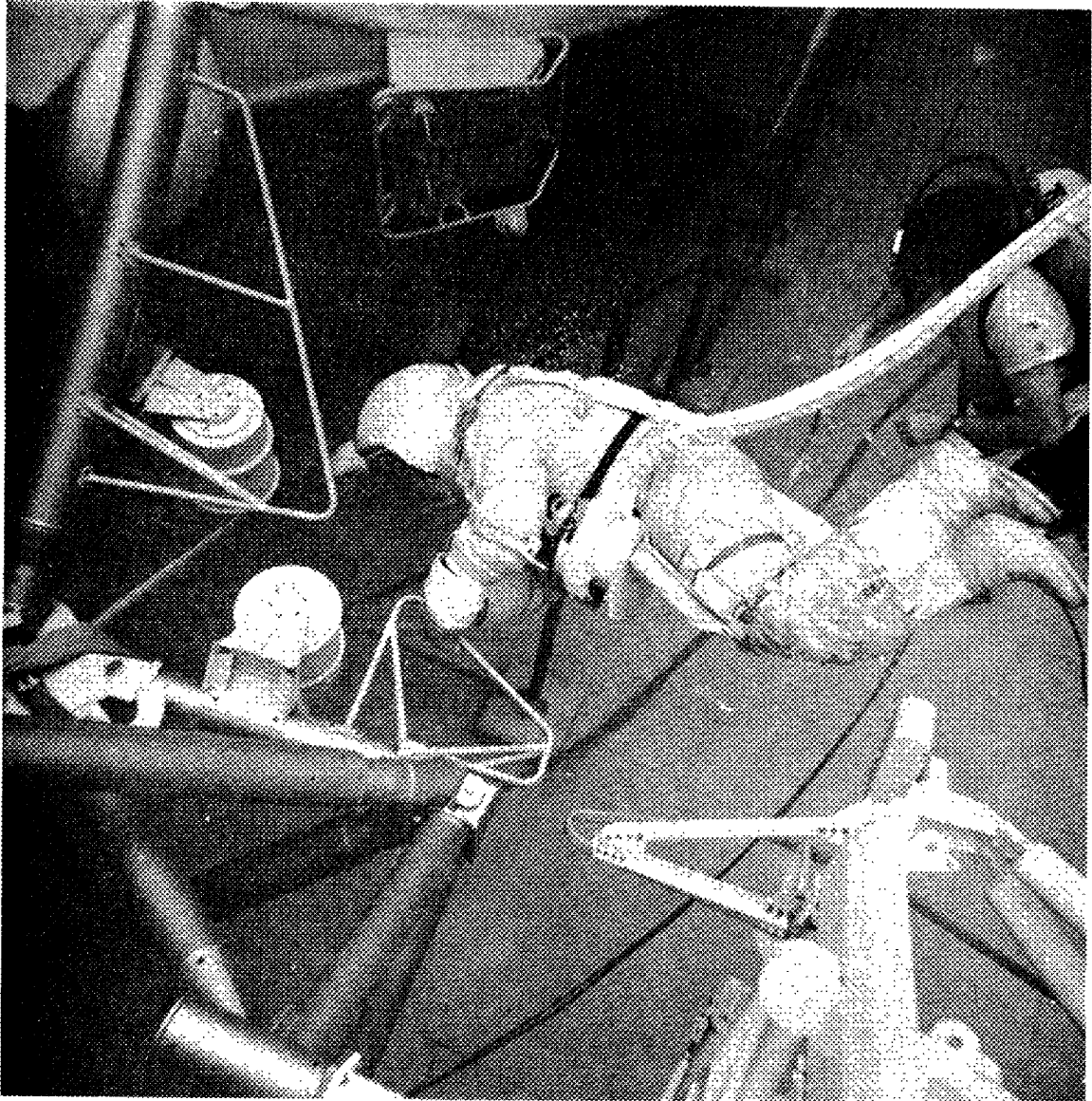

Figure 99. Crewman translating along deployment assembly handrails on the EVA route. The single handrail, shown below the crewman, leads to the ATM workstations.

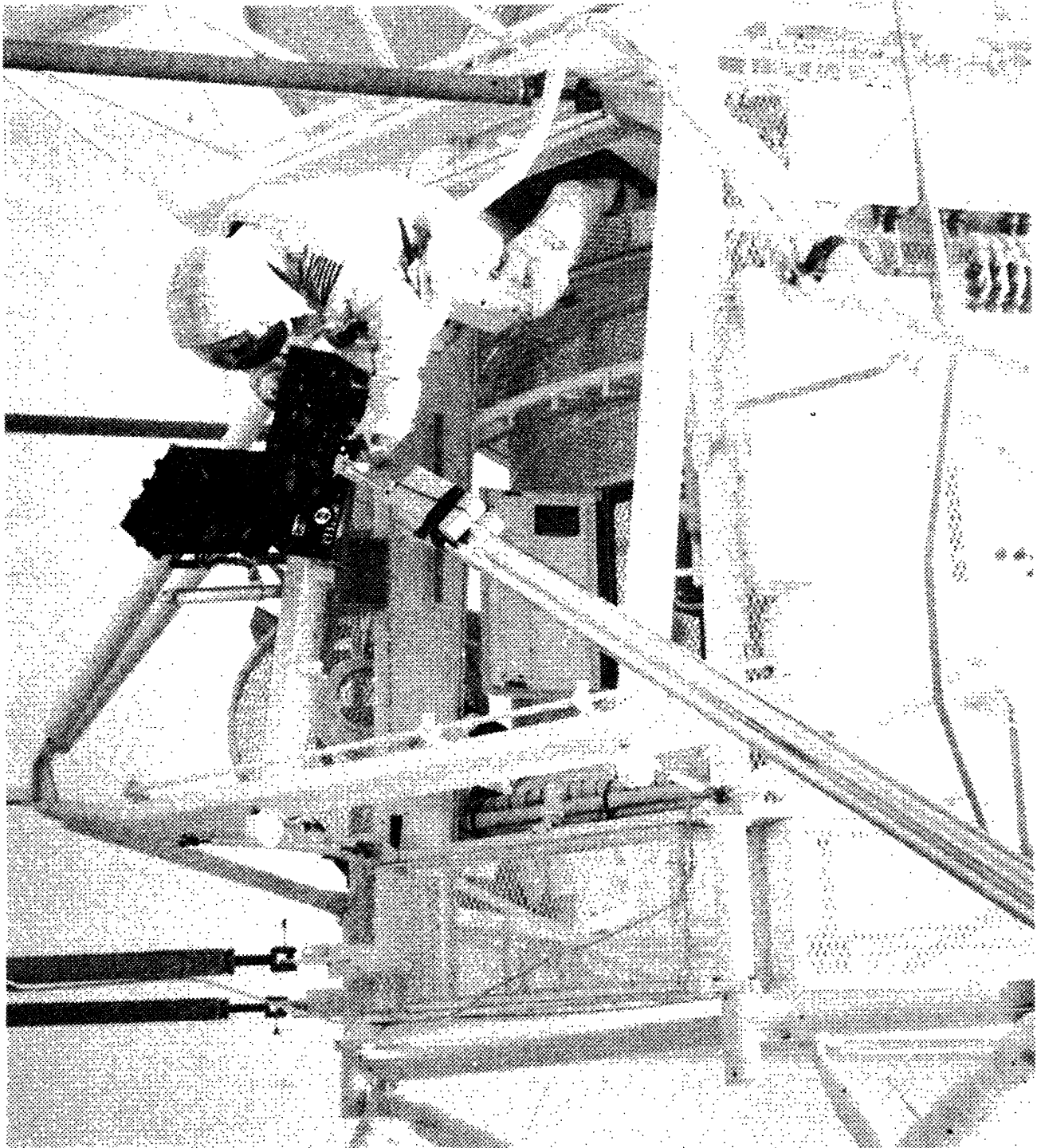

Figure 100. View of center workstation with crewman receiving replacement magazine on film transfer boom. The exposed magazine is secured to a temporary stowage hook on the clothesline bracket to the crewman's right.

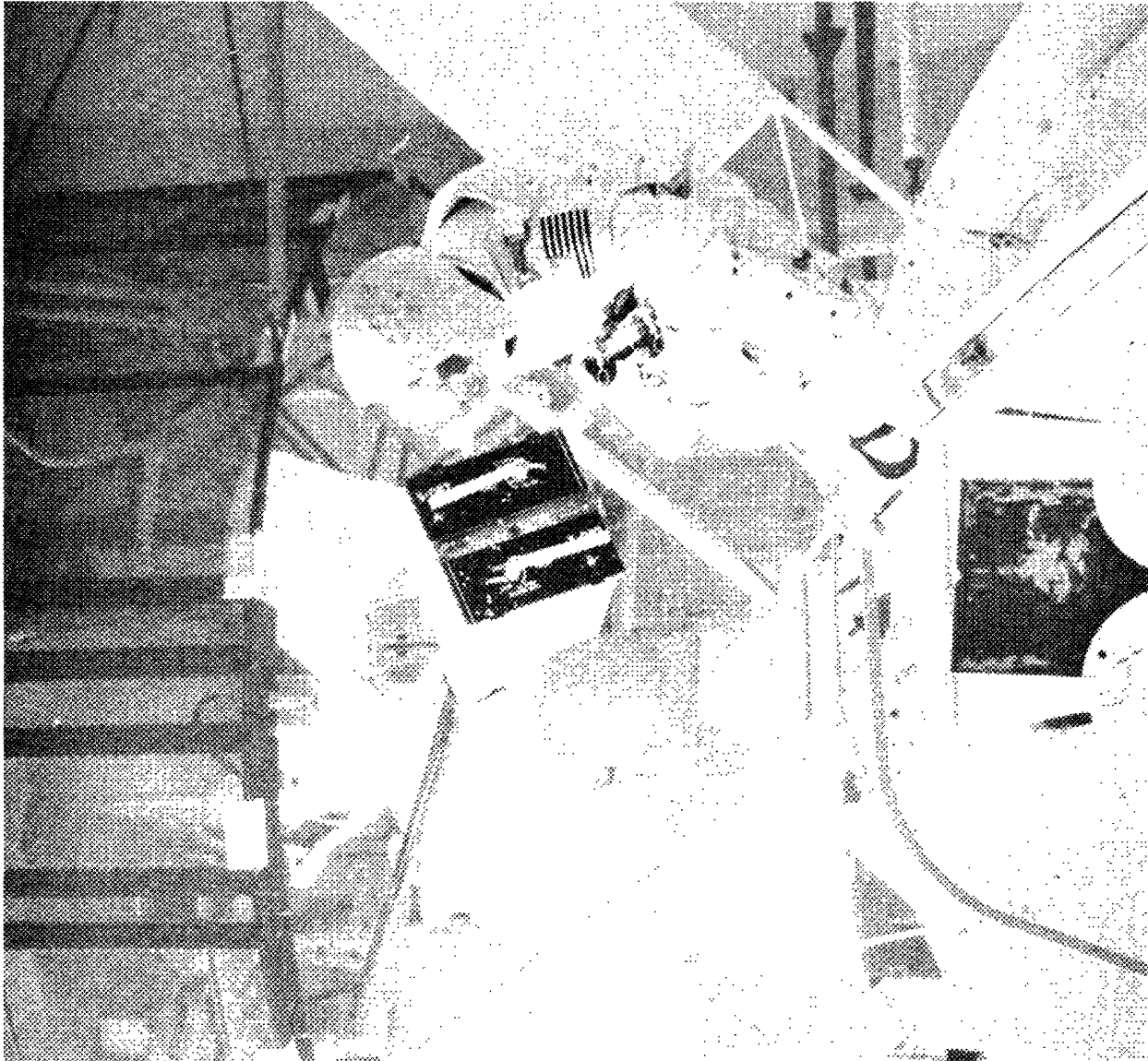

Figure 101. Crewman at transfer workstation receiving sun-end film tree on boom. The tree is removed from the boom and placed into the receptacle on the solar shield to his left.

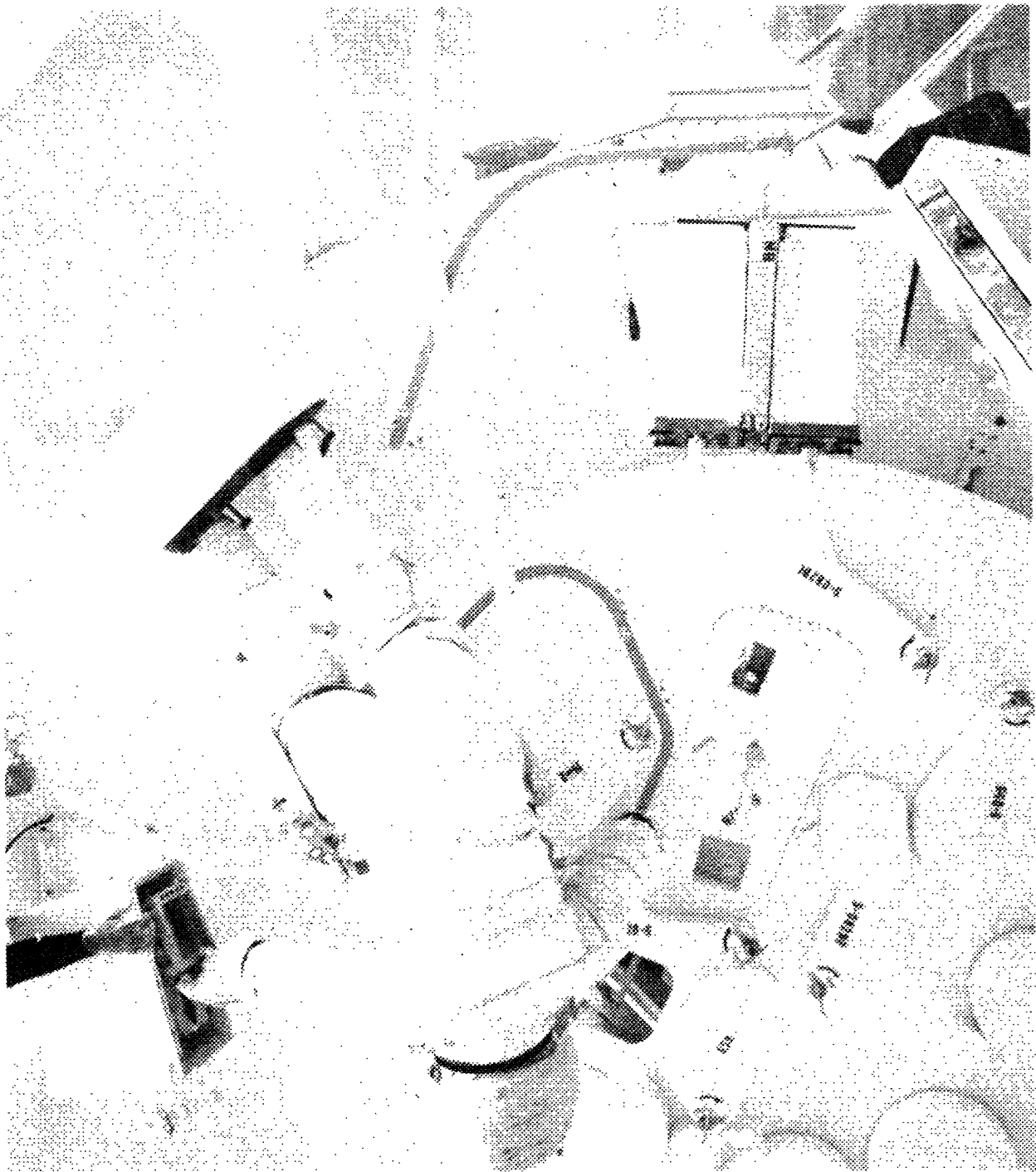

Figure 102. View of sun-end workstation with crewman placing exposed S082A film magazine into temporary stowage container. The replacement magazines are accessible from the film tree to the left of the crewman.

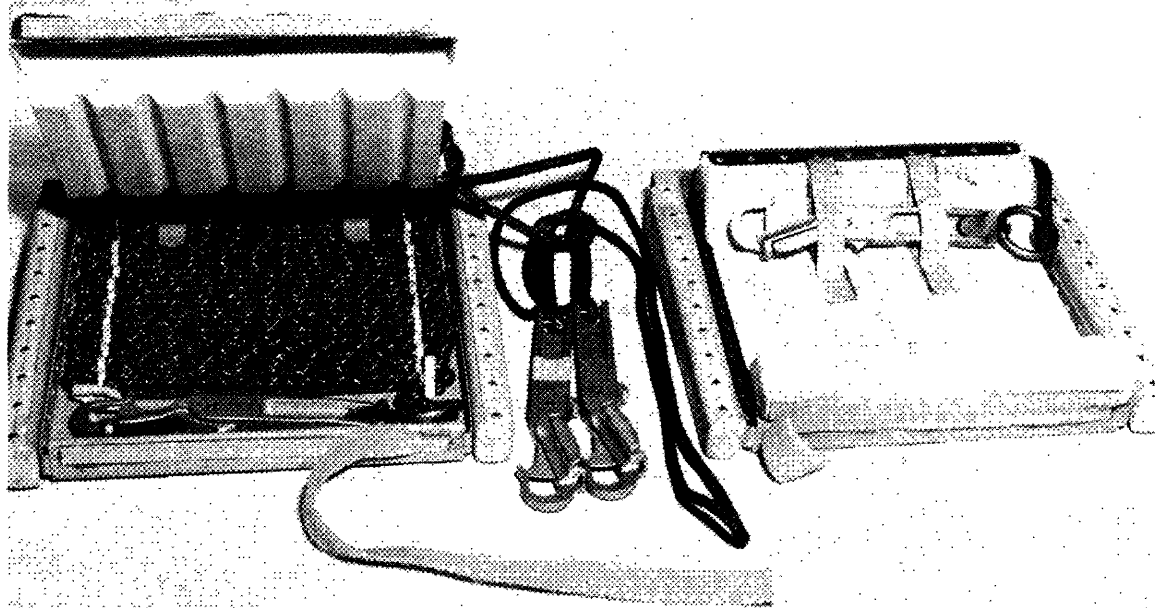

Figure 103. Clothesline Assembly and Stowage Container

film retrieval. Typical of the contingencies analyzed was a failure of the ATM solar panels to deploy after launch. Since deployment of the panel which covered the center workstation was essential for access, a manual method was devised for extending the panel during EVA. If no structural damage or jamming in the cable deployment mechanism had occurred, the torque tube could be rotated with a socket wrench, releasing the launch lock device. The panels could then be forced to an extended position by overriding a clutch in the deployment mechanism actuator. A procedure was developed in the neutral buoyancy simulator and evaluated during January 1973. The contingency solar panel deployment procedure is illustrated in Figure 108 through 111.

The techniques and procedures for resolving such hardware failures were refined continually with flight crew participation up to the launch of Skylab. The capabilities for EVA contingency operations, developed during this period, proved invaluable during the Skylab mission.

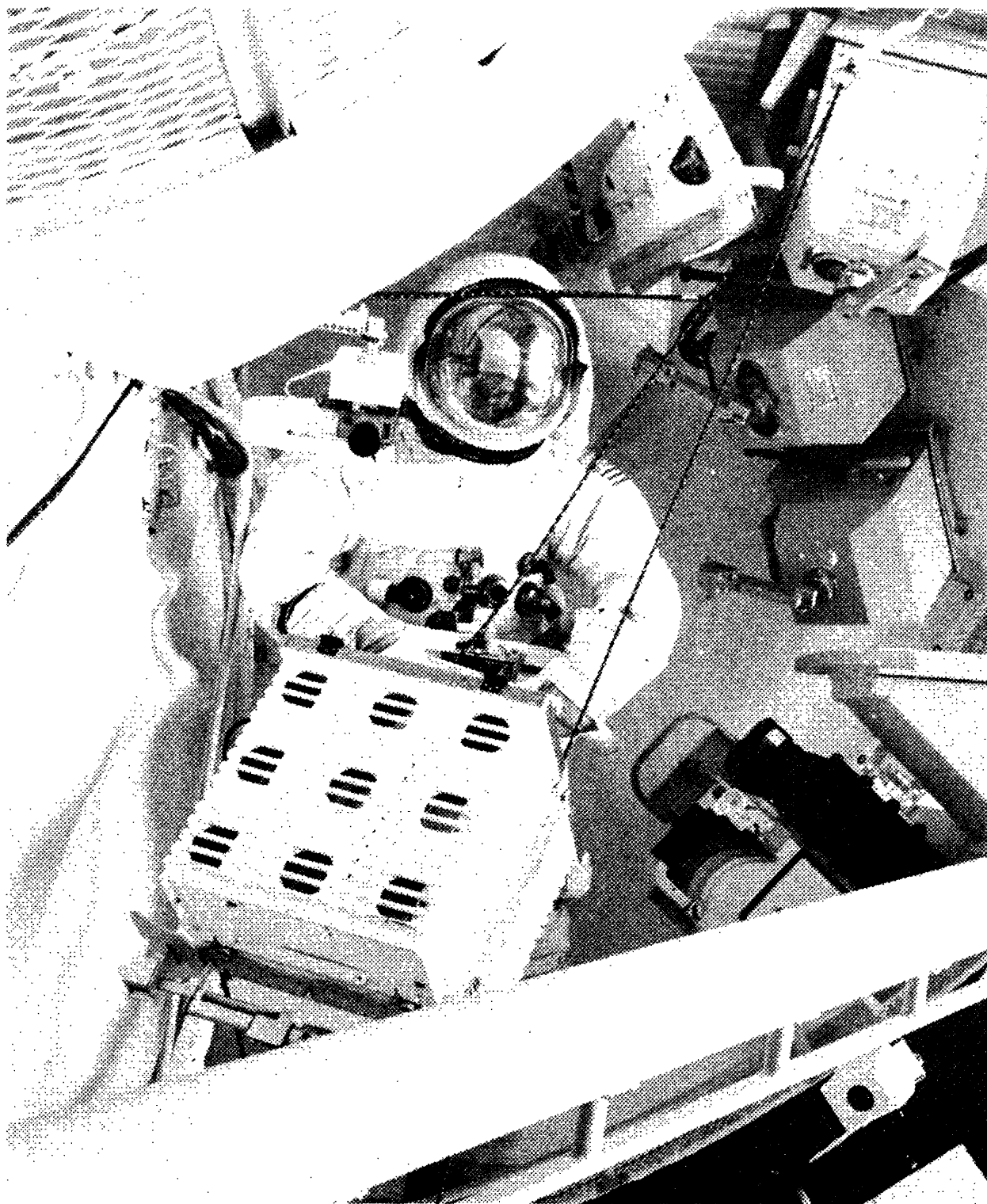

Figure 104. View of FAS workstation with deployed clotheslines. The crewman is attaching the sun-end clothesline hook to the film tree for transfer. The center workstation clothesline is kept out of the way with clips. The 16mm camera is shown in position to photograph the EVA.

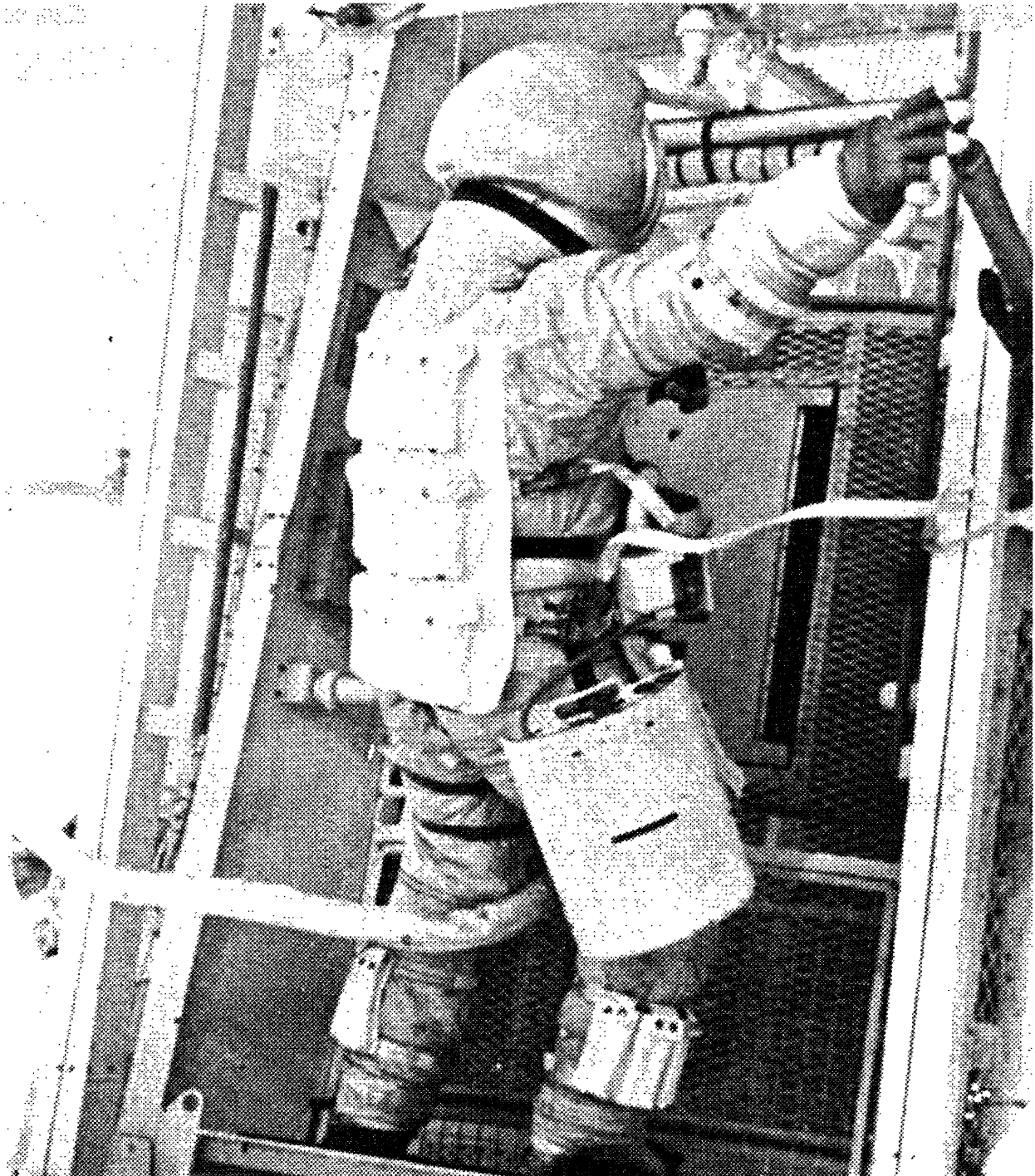

Figure 105. Crewman at center workstation attaching clothesline hook to deployed clothesline bracket.

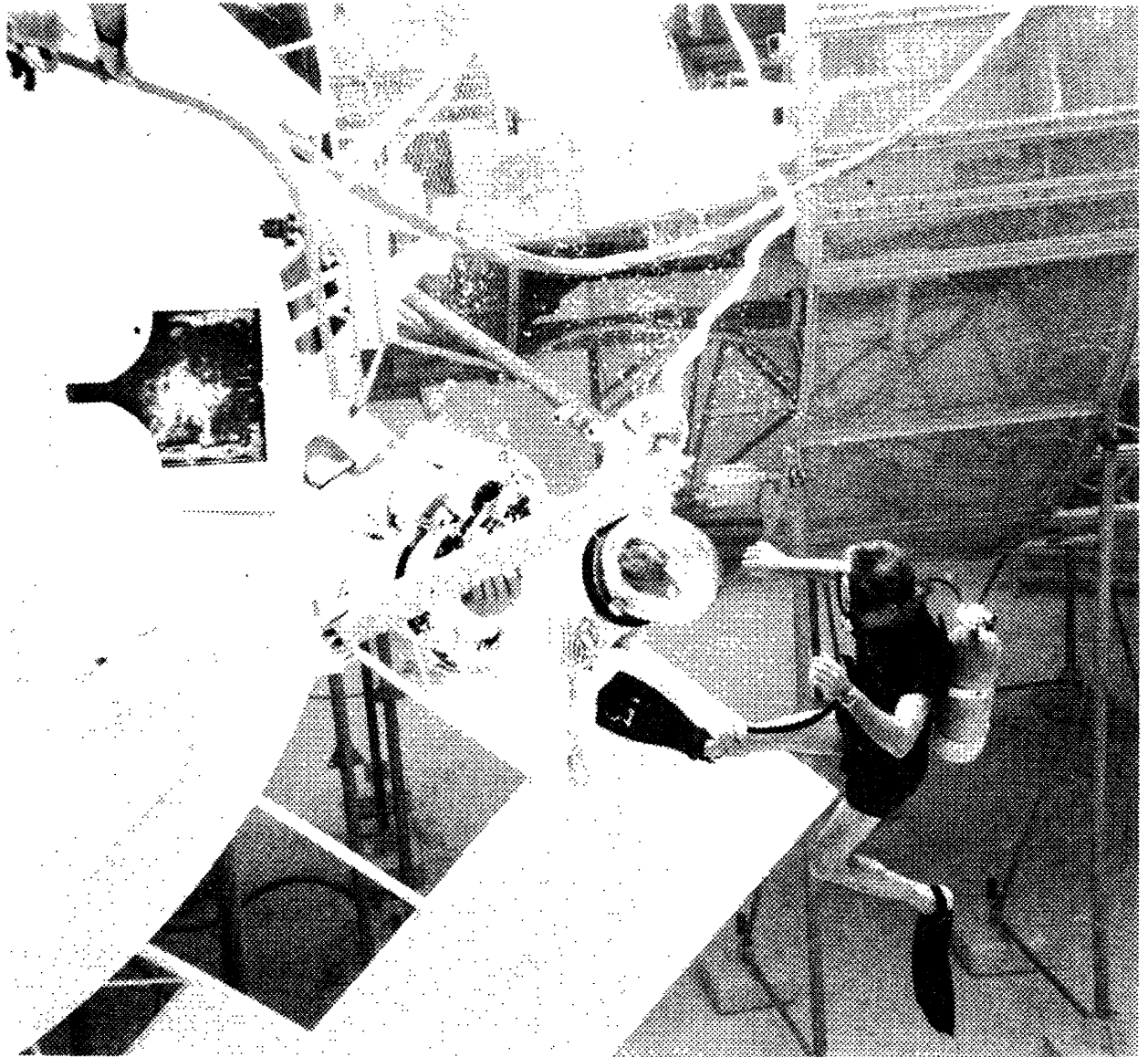

Figure 106. Crewman at transfer workstation has deployed the sun-end clothesline bracket and is attaching the clothesline hook.

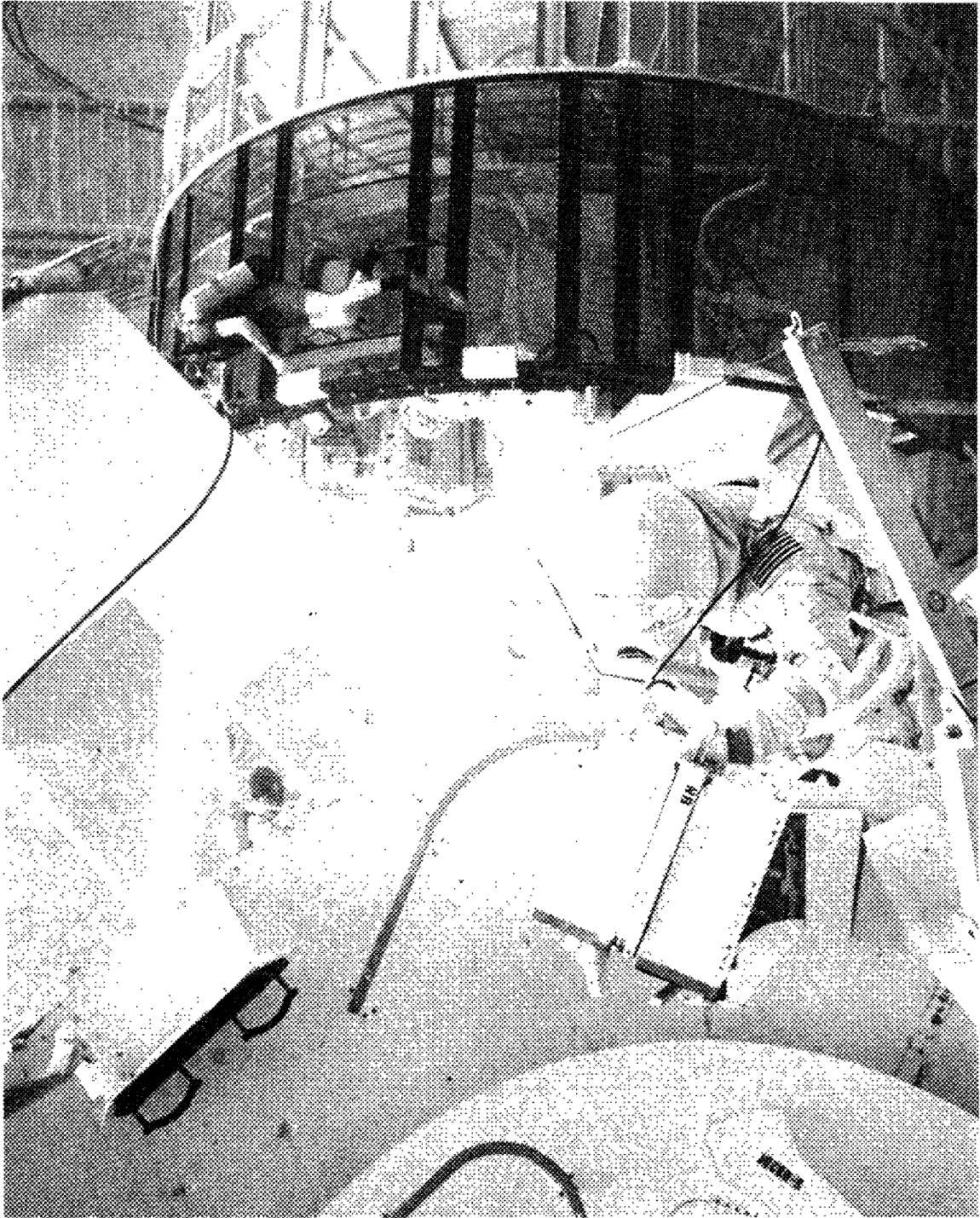

Figure 107. Crewman receiving and placing film tree in sun-end receptacle from transfer workstation.

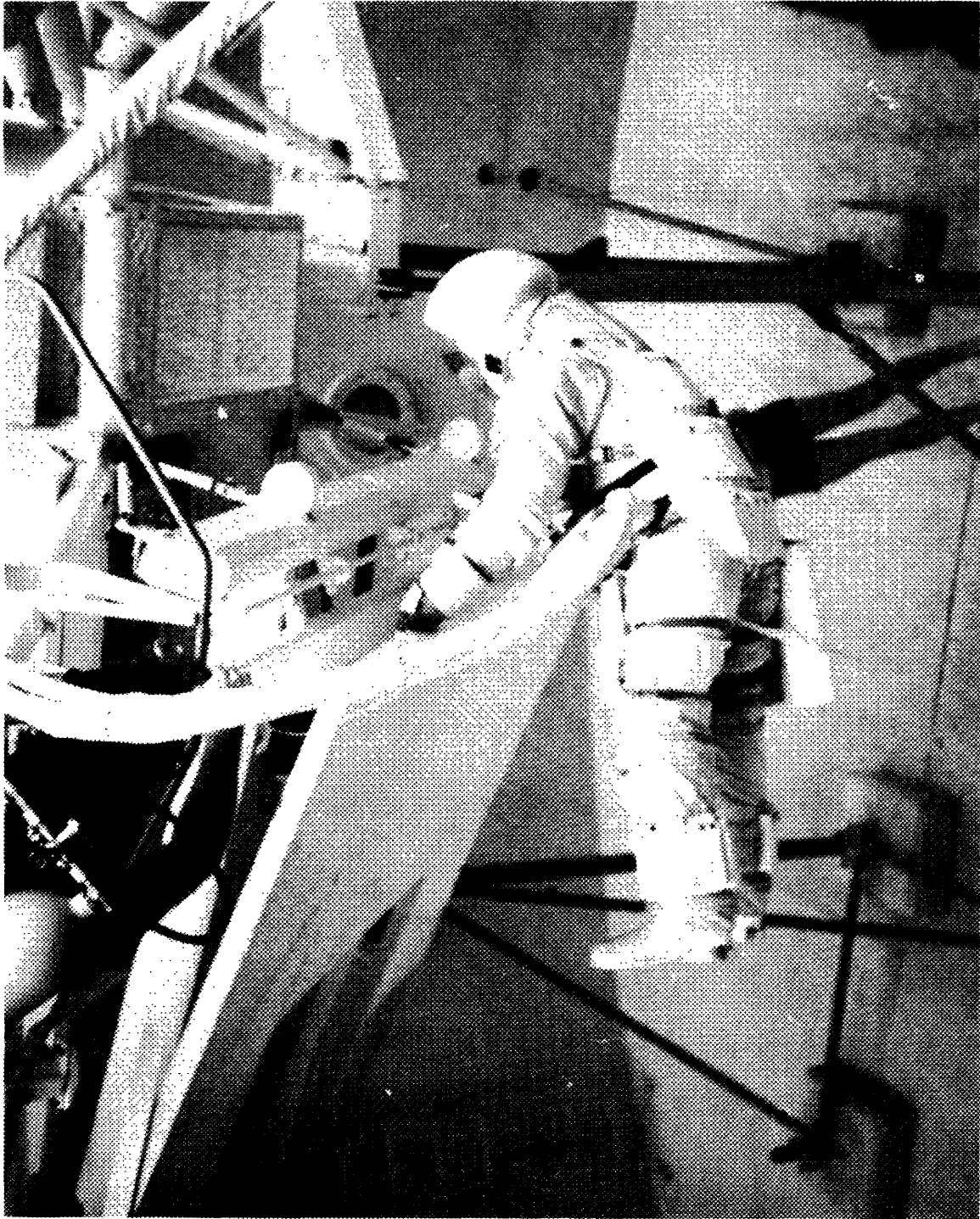

Figure 108. Crewman inspecting solar panel deployment hardware. After ascertaining that the mechanism is free of damage or jamming, he releases the panel launch lock by turning the torque tube with the socket wrench.

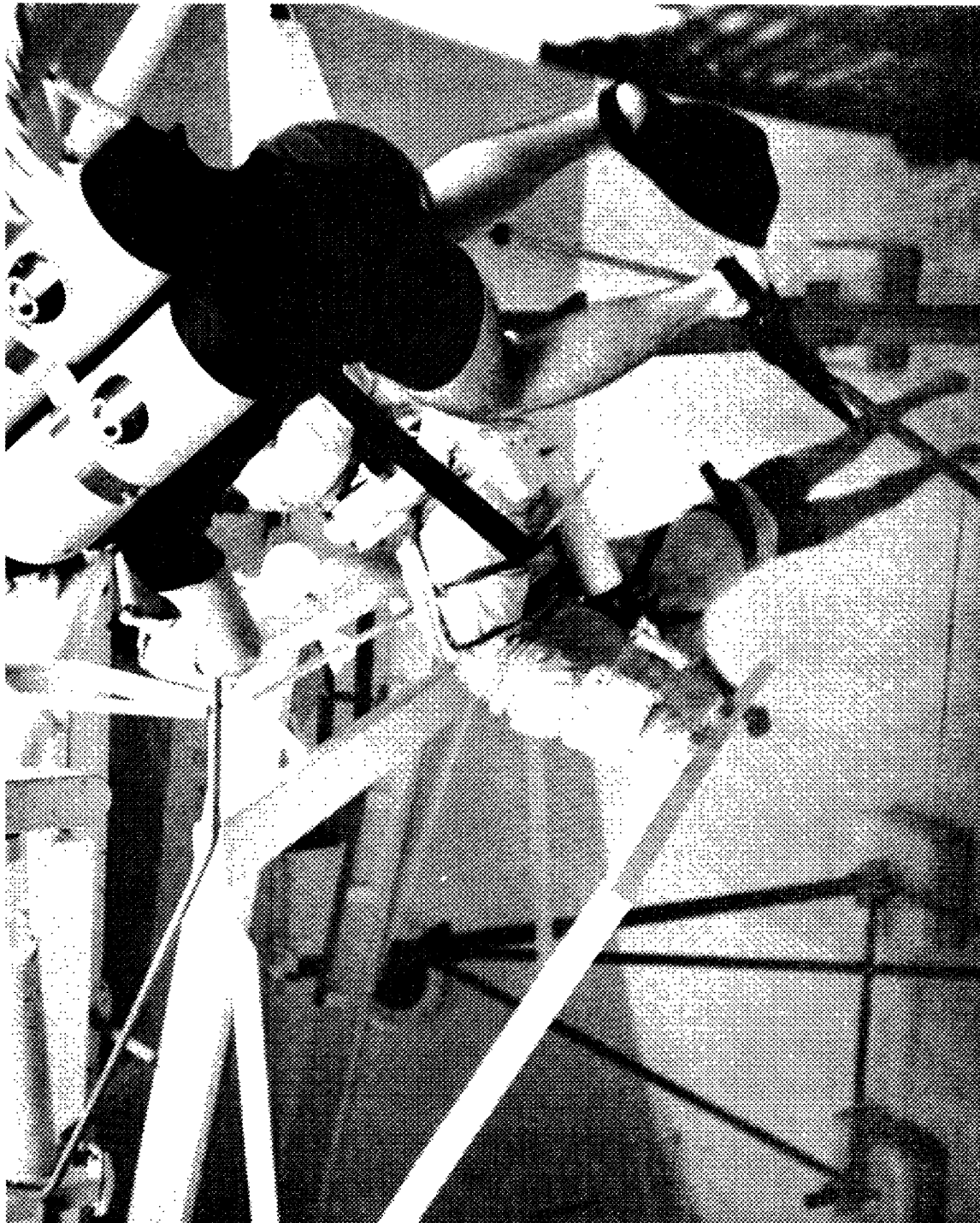

Figure 109. The crewman moves into position and using the ATM rack upper structural beam as a handrail, initiates the panel deployment by pushing with his feet.

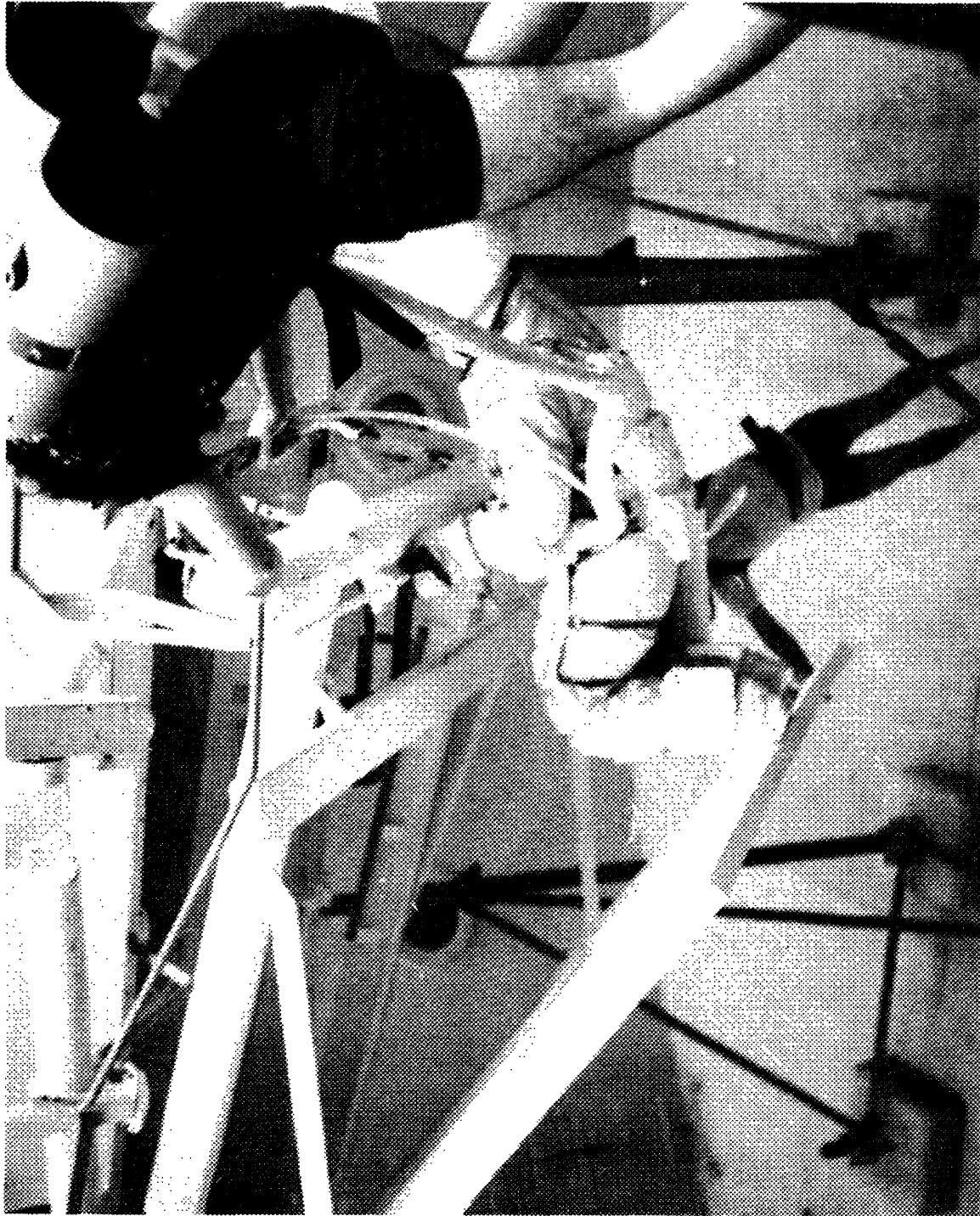

Figure 110. By shifting his position, the crewman continues the panel deployment using the torque tube as a handrail.



Figure III. In the final position, the crewman transfers his feet to force the solar panel slide bar along the support structure and completes the deployment. The center workstation is now accessible for film retrieval.

SECTION VI. CONCLUSIONS AND RECOMMENDATIONS

The Skylab EVA system was affected by several major cluster configuration changes during its development. The re-examination that occurred after each change consistently emphasized the necessity for EVA hardware to be as operationally and mechanically simple as possible. Many early constraints were conservatively imposed because of limited flight EVA experience and created needless complexity in design of the system. As our understanding of man's capabilities in the space environment increased, these constraints were relaxed and the intricate elements of the system were replaced by simpler concepts.

Two major factors which contributed to simplification of the EVA system were: (1) Recognition of the zero-g reach and visibility capabilities of a pressure-suited crewman. (Zero-g capabilities may either constrain the design approach or permit alternatives, which can easily be unrecognizable. Care must be taken to utilize all the available capability.) and (2) Careful analysis of EVA sub-task interaction which ensured overall task and equipment simplicity. (Designing for simplicity in accomplishing one sub-task may increase the complexity of subsequent sub-tasks. This interdependence must be considered to optimize the total EVA system.)

The test methods used to investigate and validate design concepts also facilitated the EVA system development effort. However, phasing of the EVA task simulations was critical for effective cost control. Early conceptual design activities should concentrate on analyses and simulation with inexpensive, low fidelity, one-g mockups to identify major design problems. Zero-g simulations during this phase should be conducted only to answer specific questions. As the design matures, the combination of one-g and neutral buoyancy simulations, with increasing hardware fidelity, is very effective in selection of the best design solution.

The same, although abbreviated, developmental approach may be followed to correct or alleviate unexpected malfunctions by EVA during a mission. After identifying all possible methods of accomplishing the task and all usable onboard equipment, several solutions will appear feasible. Those candidate solutions offering the best chance of successful development should be tried in brief simulations and a method selected. Further simulations then are used to refine the hardware design and develop flight procedures.

The orbital workshop solar array deployment development is a good example of a contingency EVA performed on Skylab. Three translation methods were identified and two different translation routes were considered. The three best options were tested in brief simulations and one selected. Three methods of erecting the array were tested and one selected. This iterative approach has been shown to be a powerful tool which need not be time consuming nor expensive.

Skylab has shown orbital EVA to be a useful adjunct to scientific missions. A conservative, simple and flexible EVA system can support many tasks with limited additional development required. An evaluation of the Skylab EVA system mission performance is presented in "MSFC Skylab Crew Systems Mission Evaluation Report," TMX-64825.

APPROVAL

MSFC SKYLAB EXTRAVEHICULAR ACTIVITY
DEVELOPMENT REPORT

By

Richard T. Heckman

The information in this report has been reviewed for security classification. Review of any information concerning Department of Defense or Atomic Energy Commission programs has been made by the MSFC Security Classification Officer. This report has been determined to be unclassified in its entirety.

This document has also been reviewed and approved for technical accuracy.

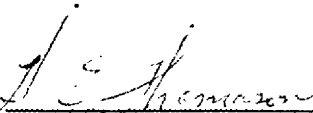

H.E. Thomason
Director,
Systems Analysis and Integration
Laboratory



R. Ise
Manager, JAN 7 1973
Skylab Program Office