

Republic of Iraq

Ministry of Higher Education and Scientific Research

Al-Mustansiriyah University

College of Engineering

Department of Engineering of Materials



Insulation Materials

For Undergraduate Students

4th Class

By: Dr. Tawfeeq Wasmi M. Salih

Academic year 2015-2016

Plan of the year

Item	Duration
Chapter One: Introduction	1 Week
Chapter Two: Thermal Insulation	5 Weeks
Chapter Three: Acoustic Insulation	4 Weeks
Chapter Four: Waterproofing Insulation	3 Weeks
Review and Course Examination	2 Weeks
Chapter Five: Radiation Insulation	4 Weeks
Chapter Six: Electrical Insulation	5 Weeks
Chapter Seven: Fireproofing Insulation	3 Weeks
Field Trip	1 Week
Review and Course Examination	2 Weeks

References:

1. Insulation Materials Science and Application, SOLAS, 2014
2. Iraqi Code of Thermal Insulation, Ministry of Construction & Housing, Iraq, 2013
3. Sound Insulation, Elsevier, Hopkins C., 2007
4. The Complete Guide to Electrical Insulation, Megger, 2006
5. Moisture Control Handbook, Lstiburek J., 1991
6. Radiation Shielding for Clinics and Small Hospitals, Hanson G., 2013

Chapter One

Introduction

Chapter One

Introduction to the Insulation Materials

1.1 Introduction

There are many benefits of home insulation. Insulating will add the comfort to the building, create a healthier home environment, reduce the energy bills and have a positive environmental impact. Adding home insulation to an existing home will regulate the temperature, making the living environment more enjoyable, especially in places of extreme weather. With insulation the home will become more energy efficient. Insulation will keep the home cooler in the summer and warmer in the winter. This will reduce the amount of heating and cooling appliances that is needed to keep the house comfortable. Because of this, home insulation will reduce the energy bills and the costs of cooling and heating. Adding acoustic insulation will also enhance the sound control. Insulation creates a sound barrier, keeping unwanted sounds out and protecting the privacy by keeping the sounds inside from being audible outside. Insulating the home also creates a moisture barrier, keeping undesirable moisture out and offers much comfortable living environment inside. Insulating the electrical outlets and the corresponding components will protect home against any electrical shock. The benefit of home insulation is not related to the occupants inside the house only but it is also extended to keep the environment out of pollutants. The insulated building will contribute to use less energy for air-conditioning. This will reduce the carbon footprint, and also reduce the amount of chemicals released into the environment from air-conditioning units. Therefore, insulation is a key element in the so-called "green home policy".

1.2 Insulation Materials

Insulation materials are made to maintain the building components and facilities as long as possible. There are many types of insulation materials according to the purpose and the structure.

1.3 Types of Insulators

1. Thermal insulators
2. Acoustic insulators
3. Waterproofing insulators
4. Radiation insulators
5. Electrical insulators

1.4 Thermal Insulators

Thermal insulators are those materials that prevent or reduce various forms of heat transfer (conduction, convection and radiation). Insulator resists the heat transfer from out to in or in opposite direction whether the environment temperature is high or low. There are many advantages of thermal insulation that isolates the building from the heat and reduces the energy consumption as well as the costs of air-conditioning operation. Also, it makes the indoor temperature of the building stable and non-volatile. To reduce the transmission of the heat, buildings must be isolated in order to protect it from heat loss in winter and heat gained in the summer. It is found that about 60% of heat losses directly through the ceilings and walls of the building and that about 15% through the glass and about 25% of the heat infiltrates through cracks, openings and doors.

To make the thermal insulation of the building an economical process, the following factors should be chosen carefully:

- The amount of insulation material and thickness
- The cost of insulation material and labor costs for installation.
- The amount of energy saving and the reduction in greenhouse emissions.

Location of thermal insulation

It is used to choose a quality of insulation material that satisfies the balance between the economic saving and the energy saving. Buildings are divided in terms of thermal insulation location into two types, buildings in warm climates and buildings in cold climates. Most of the heat that is gained in hot climates come through the outer shell of the building due to high solar intensity and the temperature differences between indoor and outdoor environment. The heat gained from external sources is higher than that comes from the internal heat generated by the various activities. The increase in thermal insulation in the outer shell of the building will lead necessarily to reduce the amount of heat gained and this consequently leads to reduce the energy needed for cooling. The U-value is a dominant factor to find the optimal thickness of the insulator in building. The amount of the total cost is equal to the total cost of insulating material plus the cost of energy saved in the building for a certain period. In cold climates, heat is transferred from inside to out, so the insulating layer should be located in the internal face of the surfaces in order to reduce the heat losses.

Types of thermal insulators

The thermal insulation refers to all isolators systems that reduce the heat transfer. Thermal insulation in buildings prevents the heat loss in winter and resists the heat from out in summer. It is looked to use best thermal insulation materials that reduces all types of heat transfer modes like conduction, convection and radiation. Glass wool is one of the most common thermal insulators as well as polyurethane, cork, polymers and many other materials.

1.5 Acoustic Insulators

Acoustic isolators prevent the permeability of sound and absorb it or try to disperse it. Sounds transmit through the air so we can distinguish the different types of voices as well as the noise. Sounds also travel as a waves through solid objects of the building specially the concrete bodies, so it should be isolated to prevent the transmission of sound from out to the inside or from one place to another.

Objective of acoustic insulation

1. Prevent transmission of sound from the outside and between the partitions through walls and ceilings.
2. Prevent the transmission of sounds and vibrations of machines.
3. Absorption of sound inside.

Architectural procedures to control the acoustics

1. Planning methods of determining the home position relative to sources of external sounds such as streets, markets and factories as well as the correct orientation of windows, doors, etc.
2. Design methods for internal spaces of the building.
3. Methods of choosing perfect soundproof material.

Types of acoustic insulators

1. Acoustic tiles and sound-absorbing tiles, made up of two sides often be grainy and of colored quartz and assembled by resin. it is characterized by its ability of durability and easy cleaning.
2. Glass wool panels which could be covered by aluminum foil to absorb sound and reject heat. It could be installed on the walls, floors and ceilings
3. Plastic layers that might be perforated or grainy face.
- 4 Sheets of cellulose compressed and perforated face.

5. Slabs of gypsum with the possibility of adding glass fibers.
6. Polymers like rubber, cork (EPS), foam.
7. Rocks like Perlite.

1.6 Waterproofing Insulators

All buildings need insulation from moisture, rain, groundwater and surface water because the moisture helps to damage the elements of construction and their materials and release undesired smells with the breeding of insects and mice and bring diseases. The walls that are exposed to the rain without sufficient amount of sunlight are more susceptible to moisture.

Effect of dampness

- Damage of building materials and elements of the house
- Efflorescence of the walls, floors and ceilings.
- Damaging the paint.
- The failure in the timber used and wooden decor
- Corrosion of metallic parts.
- Proliferation of fungi and unhealthy situation for users in the building.

Causes of dampness

1. Rain water: The rain water has the ability to penetrate the poor surfaces of the roof especially in absence of gutters. Rain could penetrate the external windows in absence of overhangs.

2. Surface water: This means river, sea or pond, where the water mixes with the soil close to the building and because clay near the foundations then moisture seeps to the foundations or inside through the capillary action.

3. Underground water: which is formed by the accumulated water under the earth's surface. Water transmits through the pores in the soil by the osmosis phenomenon and reaches the foundations of the building.

4. Condensation: it noticed in winter days a layer of dew formed on the window or even wall, and this phenomenon is called "condensation". The accumulated moisture on windows, walls, ceilings and floors seeps into parts of the house after a period of time and leads to the fragility of construction materials and the appearance of rust, mildew and odors.

5. Poor sewage drainage: When wastewater gathers under the building and it was hard to flow downstream because of some restrictions then dampness could be occurred in the nearby elements of the building.

6. Modern construction: the walls newly constructed remain in the wet state for a certain period.

Types of waterproofing insulators

It is advised to use and install barriers to prevent water leakage into the different parts of building elements. The common waterproofing materials are: asphalt, flancoat, bitumen, polyethylene White cement, asbestos and acrylic

1.7 Radiation Insulators

Radiation energy is released in the form of electromagnetic waves such as light, UV, infrared, x-ray and gamma, as shown in the figure below, or as small particles such as alpha and beta,.

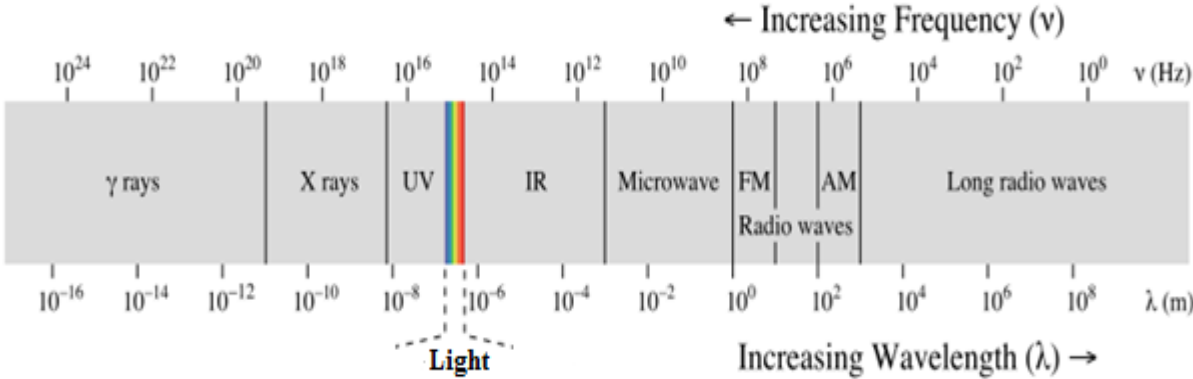

Fig (1.1) Electromagnetic waves

Radiation comes from cosmos, sun, earth, nuclear reactors, and various devices or even inside the body. Radiations that come from sun like (Gamma, UV, light and IR) have short wave lengths. Radiation with a long wavelength called microwaves or radio waves.

How dangerous exposing to radiation

When the radiation passes through a medium, it helps to detach electrons from atoms or molecules, and this is called "ionization". If the ionizing radiation is higher than the threshold level, then serious effects occur such as skin redness, hair loss, burns, radiation syndrome and in some cases cancer.

Means to minimize the risk of radiation

There are three aspects to reduce the risk of radiation which are:

1. **Time:** it is advised to reduce the exposure time (time spent by the person next to the radiation source).
2. **Distance:** the greater the distance between the person and the radioactive source the less the proportion of exposure (by inverse-square law)
- 3- **Shields:** barriers around the radioactive source will reduce exposure.

Types of radiation insulators

There is appropriate shield for each type of radiation, as shown in the figure.

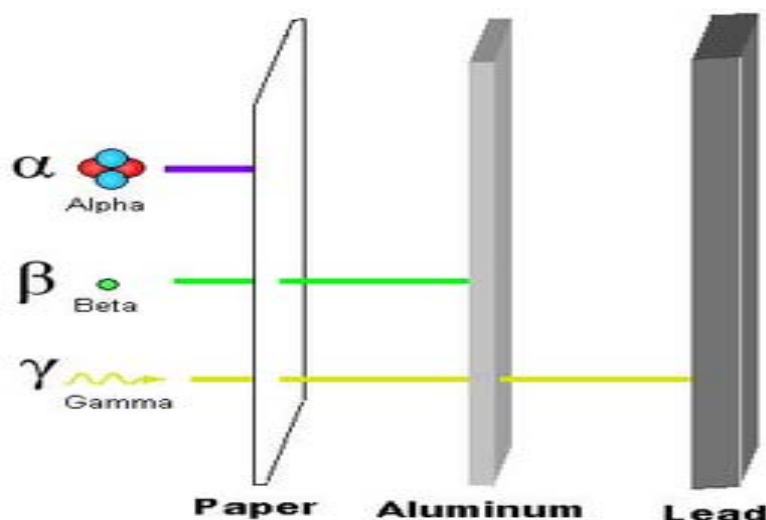

Fig. (1.2) Shielding for some types of radiation

1.8 Electrical Insulators

Any substance contains a number of atoms. These atoms have some electrons in the outer orbit called "free electrons". It is such easy to expel the free electrons from the external orbit and make it move to another atom. The flow of electrons from an atom to another is called "electrical current". Some materials do not allow the flow of electric current, then it is called "insulators" such as: wood, plastic and ceramic. The main reason of how these materials restrict the electrical flow is that their atomic structure contains a very small number of free electrons midwife to move. The electric field still active even in an insulating material, where an imbalance occurs and the positive charges attract to the electric field while the negative charges displace away. This separation between electrical charges generates the "dipole" and the corresponding process called "polarization".

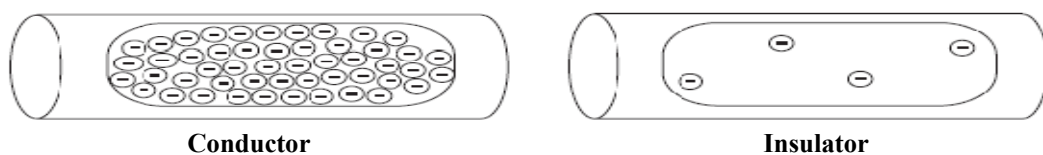

Fig. (1.3) Comparison between electrical conductor and insulator

There are many types of insulators in electrical systems for various purposes and uses. For example, plastic is used to cover the electrical wires to protect against electrical shock. Many other examples of electrical insulation materials like: rubber, wood, ceramics, paper, glass and oils.

Properties of electrical insulators

1. **Resistance:** which is the ability of the material to repel the electrical current.
2. **Permittivity:** which increase the ability of the insulation to absorb more amount of electrical charges and avoid the transfer of energy. The best insulator is that which has a large permittivity.
3. **Polarization:** which is the ability of insulating material to undergo the separation between electrical charges and its strength.

Chapter Two

Thermal Insulation

Chapter Two

Thermal Insulation

2.1 Thermal Insulators

Those materials that prevent or reduce various modes of heat transfer (conduction, convection and radiation) from the outside to the inside or vice versa, whether the environment temperature is high or low.

2.2 The Advantages of Thermal Insulation

1. Reduce the amount of heat transmitted through the parts of the house.
2. Reduce the energy required for heating or cooling the house.
3. Make the internal temperature of the building stable, non-volatile.
4. Keep the temperature of the building elements stable thus long time life.
5. Reduce energy bills.
6. Reduce the burning of fuel in power plants.
7. Reduce the emission of greenhouse gases.

2.3 Classification of Thermal Insulators

- ***According to the structure***
 1. Organic materials, such as cotton, wool, cork, rubber and cellulose.
 2. Inorganic materials: such as glass, asbestos, rockwool, perlite, vermiculite and calcium silicate.
 3. Metallics: such as aluminum foils and tin reflectors.

- ***According to the Shape***

- Rolls: vary in the degree of flexibility and the ability to bend or pressure. They could be fastened by nails like glass wool, rock wool, polyethylene and foil-ceramic rolls.
- Sheets: There are specific dimensions and thicknesses such as polyethylene layers, polystyrene, cork and cellulose.
- Liquid or gaseous fluids: poured or sprayed on to form the desired dielectric layer, such as polyurethane foam and epoxy.
- Grains: a powder or granules are usually placed in the spaces between the walls and it can also be mixed with some other materials. Examples of such materials granulated cork and polymers.

2.4 Commercial Insulators

The thermal insulation refers to all isolators systems and processes that reduce the heat exchange between inside and outside. Thermal insulation in buildings in hot climates is designed to prevent the entry of heat to the building. Thus, the using of thermal insulation materials reduces the heat transfer. The most important thermal insulators are glass wool, cork, polyurethane and other polymeric materials as well as evacuated panels. It should refer here that air is one of the best thermal insulators due to its low coefficient of thermal conductivity (0.025 W/m.K) and availability everywhere.

The most common insulators:

1. Cellulose: which is made from wood or recycled paper and is characterized by its susceptibility to water and dust absorption.
2. Cork: This is taken from cork tree. It could be made industrial from petroleum product which is called the Expanded Polystyrene (EPS). It is found in the form of panels and used as thermal and acoustic insulators.

3. Glass wool: are widely used to insulate buildings, as well as boilers and reservoirs.
4. Rock wool: This material is used to isolate the buildings and storages.
5. Polyurethane: usually uses as insulated panel or foam to fill the cracks.
6. Polystyrene cork: both types, EPS and XPS
7. Astrofoil (XPE) layers: consist of two aluminum foils and including air bubbles which are made of polyethylene materials. The aluminum layers reflect the solar radiations in the summer while the air bubbles reduce the heat transfer through the walls because of high air isolation. This material is a good insulator against the water and air leaks.
8. Polycarbonate panels: These sheets are lightweight panels, and are composed of several layers to be able to withstand the shocks with the presence of air cavities for the purposes of thermal insulation.
9. Reflective materials: such as aluminum panels, alu-cobond and reflective paints. These materials are used to reflect solar radiation on the exterior walls.
10. Fire retardant sheets: are wooden panels characterized by their ability to delay the fire growth in addition to the thermal insulation ability.



Glass Wool



EPS

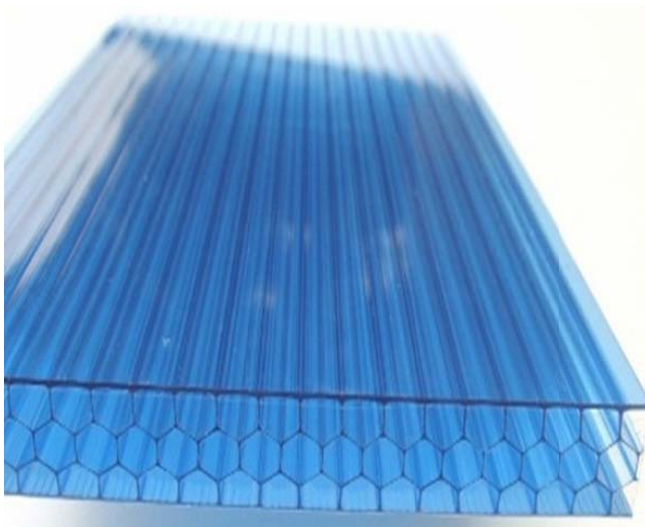

polycarbonate sheet



Polyurethane panel



Ceramic roll

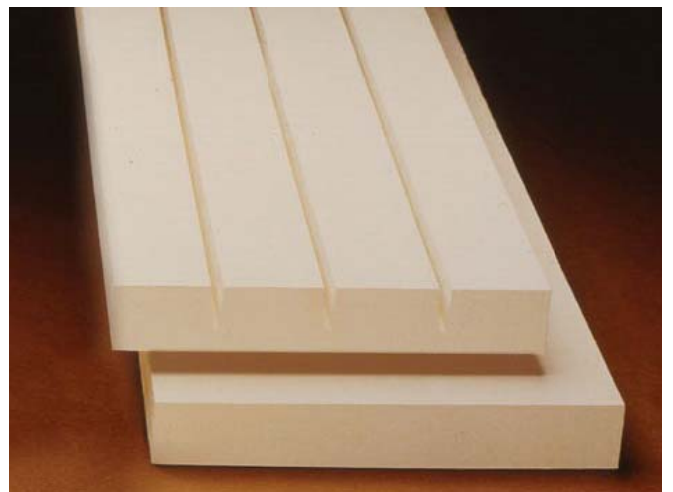

Calcium silicate

Fig. (2.1) Thermal insulators

2.5 Phase Change Materials (PCM)

Those materials that consequently oscillating between liquid and solid phases, hence absorb or release heat depending on the surrounding temperature. Many substances that can act as phase change materials such as paraffin and salt hydrates.

These materials could be used in moderate warm climate where the ambient air is hot at the daytime and cool nightly. In the warm daytime, this material absorbs the heat from indoor air and turns to be in the liquid state. In the cold night, the material releases the heat and turns to be in the solid state again. By repeating this process, the indoor air temperature remains stable without electricity.

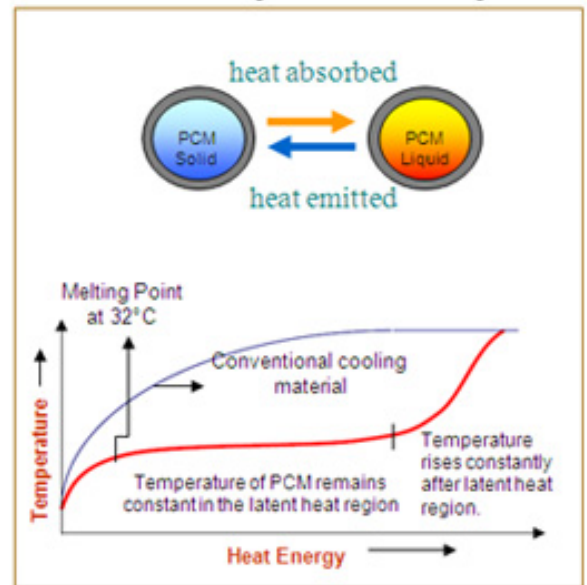

Fig. (2.2) PCM behavior

National Gypsum has produced a phase change drywall with the following specifications:

- The phase change material is Micronal Paraffin
- Tiny spheres of paraffin (5-10 micrometers in diameter) are encapsulated in acrylic shells, and these are mixed with the gypsum in drywall.
- Melting temperature is 24 °C and could be operated till 32 °C.
- Heat capacity is 125 W/m².

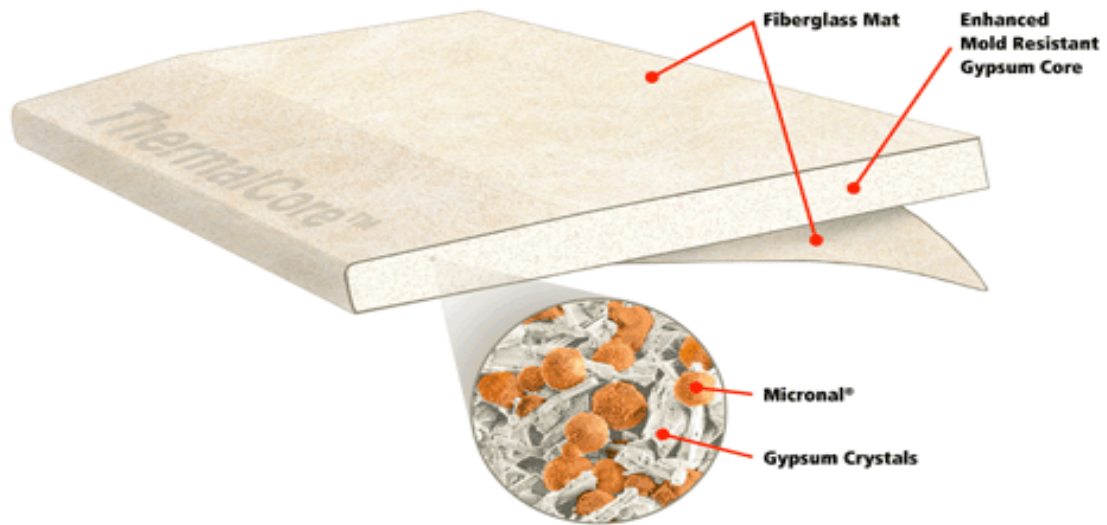

Fig. (2.3) Micronal paraffin

2.6 Thermal Properties of Insulator

Like the thermal conductivity coefficient, the less conductivity coefficient indicates the better resistance to heat transfer. The other thermal properties are: reflectivity, absorptivity, heat capacity, density, coefficient of thermal expansion and the coefficient of thermal bridging.

Thermal conductivity: it is the property of a material to conduct heat. Heat transfer occurs at a higher rate across materials of high thermal conductivity than across materials of low thermal conductivity. Correspondingly, materials of high thermal conductivity are widely used in heat sink applications and materials of low thermal conductivity are used as thermal insulation. The thermal conductivity of a material varies with the temperature. The reciprocal of thermal conductivity called thermal resistivity. There are a number of ways to measure thermal conductivity of a material using the conductivity meter aperture. The unit of thermal conductivity is (W/m.K).

Table (2.1) Thermal conductivity for common insulators

Item	Material	Thermal Conductivity (W/m.K)
1	Astro-foil (XPE)	0.08
2	Asbestos	0.12
3	Asphalt	0.69
4	Alucobond	0.15
5	Acrylic	0.2
6	Aerogel	0.02
7	Bitumen	0.17
8	Calcium silicate	0.05
9	Cellulose	0.08
10	Coal	0.24
11	Cotton	0.04
12	Cork (EPS)	0.05
13	Ceramic fiber	0.08
14	Engine Oil	0.15
15	Epoxy	0.35
16	Glass Fiber	0.03
17	Glass Wool	0.04
18	PVC	0.2
19	Paraffin Wax	0.25
20	Plywood	0.13
21	Polycarbonate	0.19
22	Perlite	0.05
23	Polystyrene (XPS)	0.08
24	Polyurethane	0.02
25	Rubber	0.35
26	Vacuumed panel	0.007
27	Vermiculite	0.06
28	Wool	0.05

Table (2.2) Thermal conductivity for common construction materials

Item	Material	Thermal Conductivity (W/m.K)
1	Basalt	2.3
2	Block (Hollow) - 20 cm	0.5
3	Block (Hollow) – 15 cm	0.6
4	Block (Hollow) – 10 cm	0.7
5	Block (Solid)	0.9
6	Brick (Cavity)	0.4
7	Brick (Solid)	0.5
8	Concrete (Reinforced)	2
9	Concrete (Not Reinforced)	0.8
10	Cement plaster	1
11	Clay	1.2
12	Dry Wall – 10 cm	0.3
13	Granite	3
14	Gypsum	0.8
15	GRC	0.9
16	Glass	1
17	Limestone	1.5
18	Mica	0.7
19	Marble	2.2
20	Porcelain	1.5
21	Sandstone	1.5
22	Sandwich Panel – 10 cm	0.04
23	Sandwich Panel – 5 cm	0.05
24	Thermostone – 20 cm	0.3
25	Thermostone – 10 cm	0.4
26	Wood	0.15

Table (2.3) Thermal conductivity for common metals

Item	Material	Thermal Conductivity (W/m.K)
1	Aluminum (AL)	200
2	Bronze	110
3	Copper (Cu)	400
4	Iron (Fe)	80
5	Lead (Pb)	35
6	Silver (Ag)	450

Table (2.4) Thermal conductivity for common gases

Item	Material	Thermal Conductivity (W/m.K)
1	Air	0.025
2	Argon	0.015
3	Bromine	0.04
4	Carbon dioxide (CO ₂)	0.014
5	Helium	0.15
6	Methane	0.03

Reflectivity: it is the ratio of reflected radiation from a surface to the total incident radiation. The factors affecting the amount of reflectivity are the color and the level of fine-tuning the surface. The following table shows values of reflectivity for some materials.

Table (2.5) Reflectivity for common materials

Material	Reflectivity (%)
Aluminum	80
Gypsum	70
Cork	45
Concrete	35
Plastic	20
Wood	17
Glass	10
Asphalt	3

Absorptivity: it is the ratio of absorbed radiation by the surface. The color of the surface affects the amount of absorption. The following table shows absorptivity values for some materials.

Table (2.6) Absorptivity for common colors

Color	Solar Absorptance
Green	0.47
Ochre	0.6
Dark Beige	0.7
Blue	0.7
Red	0.75
Brown	0.75
Dark Brown	0.83
Dark Colors	0.9
Black	0.95

Heat capacity: it is the ability of material to store the heat. The material with high heat capacity is called **thermal mass**

Density: it is the mass of matter in a certain volume. The unit is (kg/m³).

Thermal expansion coefficient: is the amount of change in the volume of material as a result of temperature change.

Coefficient of thermal bridge: which describes the amount of heat transfer in certain areas called thermal bridges. Thermal bridge is an area in the building envelope in which the highest heat transfer compared with neighboring areas, this causing the failure of building materials, the spread of moisture and mold growth. Examples of these areas:

- The joints between the ceiling and walls
- Link areas between windows and walls
- Piles and foundations

Table (2.7) Thermal properties of some materials

Item	Material	Specific Heat (J/kg.K)	Density (kg/m ³)
1	Brick	850	1900
2	Concrete	900	2500
3	Granite	900	2750
4	Thermostone	750	890
5	Aluminum	900	2700
6	Iron	450	8000
7	Wood	1700	750
8	Rubber	1600	950
9	Marble	850	2800
10	Glass	600	2500
11	Water	4200	1000
12	Gypsum	1000	1500
13	EPS	1500	24
14	XPS	1900	32
15	Glass wool	700	24
16	Cellulose	1750	1200
17	Polyurethane	500	12

2.7 Other Features of Thermal Insulators

Mechanical: Such as durability, compression, tensile and shear stresses. Some insulators are characterized by strength and endurance than others. That makes sense to be used for supporting of the building beside to the goal of thermal insulation.

Moisture absorption: The presence of water or humid air in the insulator reduces the thermal insulation value of the material and it may destruct the material rapidly. The moisture is measured by the effect of moisture absorption and permeability.

Acoustical: Some insulating materials may be used as acoustic insulators as well as thermal insulators.

Safety: Some insulating materials could get hurt to human during storage, installation and usage. These may cause deformities in the human body, poisoning, infections or allergies in the skin and eyes, which requires importance of knowing the chemical composition of the material and ability to interact with the environment and constitute a mold, germs and insects. There are some physical properties should be considered like the ability of combustion and sublimation.

2.8 Modes of Heat Transfer

1. **Conduction:** it is heat transfer through the wall thickness from the hot face to the cold one. The thermal conductivity varies from a substance to another. For example, concrete and steel have high conductivity compared to an insulating material such as cork. The amount of heat transfer by conduction depends on the temperature difference between the surfaces of the wall, wall thickness, area of surfaces exposed to heat and coefficient of thermal conductivity of the material, as well as the lag time (period of accumulated heat).

2. **Convection:** it is the transfer of heat due to the ambient air nearby the wall. where, the air molecules move from hot zone to cold zone carrying the thermal energy away and replaced by air molecules have cold temperature and less density. This process is known as convection current. Air movement helps to increase the heat transfer rate.

3. **Radiation:** it is the transfer of radiant heat that does not require necessarily a medium, like the heat of the sun to the earth. The radiant heat is transferred from the source to the colder places. The reflective surfaces such as metal foils reflect thermal radiation and reduce heat absorption by the walls.

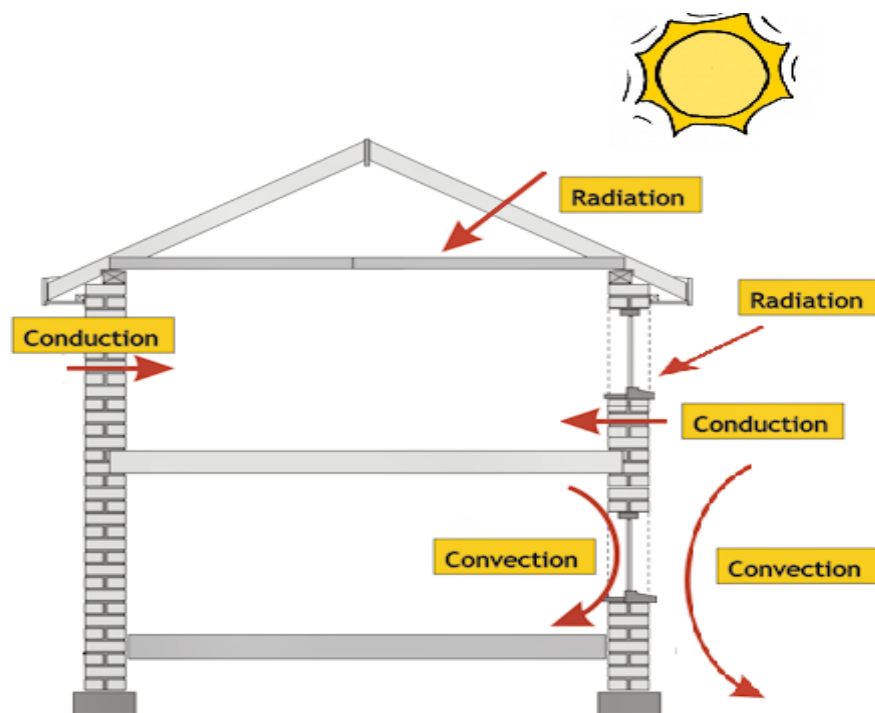

Fig. (2.4) Modes of heat transfer through the building

2.9 Thermal Insulation in Buildings

Buildings could be divided in terms of the acquisition method of heat into two types, which are buildings in hot climates and buildings in cold climates. In hot climates, most of the heat is gained from the outside through walls, ceilings and windows. The increase in thermal insulation in the outer shell of the building will lead necessarily to reduce the amount of heat gained and this consequently leads to reduce the energy needed for cooling. But in cold climates, heat is transferred from inside to out. Therefore, the insulating layers are placed inside.

It is found that the heat transfer through the house parts are as follows:

- About 60% of the heat is transmitted through the ceilings and walls of the building.
- About 15% of the heat is transmitted by the windows.
- About 25% of the heat is transferred through the vents and doors of the building.

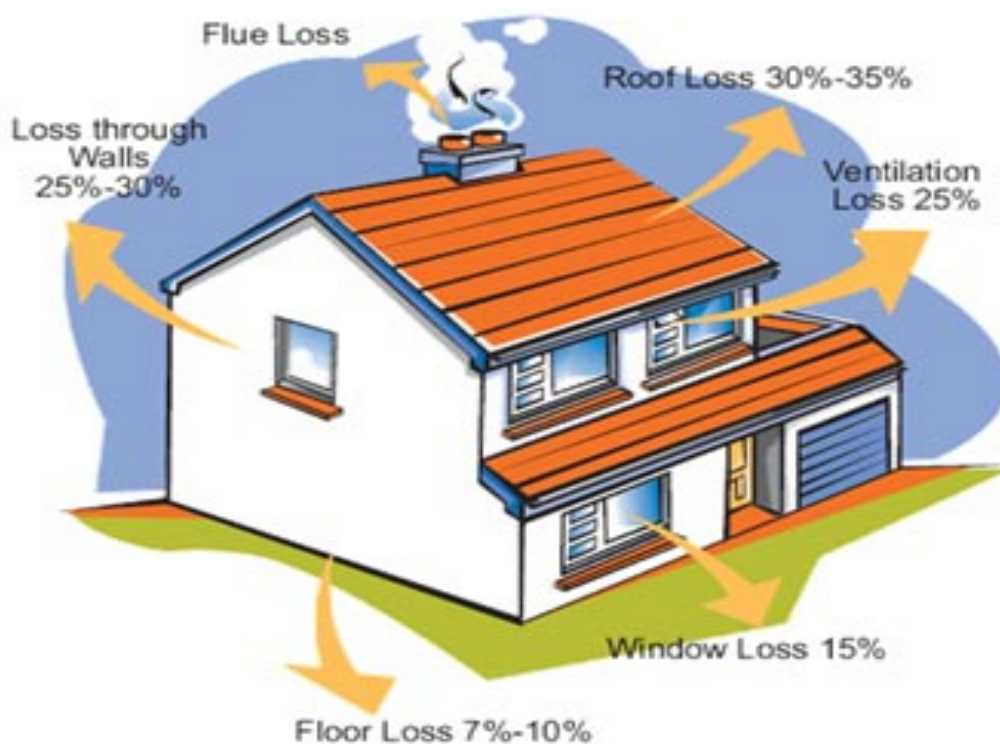

Fig. (2.5) Contribution of buildings elements in heat transfer

2.10 Thermal Insulation Expression

There are some concepts must be defined before entering to the design, such as:

Thermal resistance: it is the susceptibility of the material to resist the heat. Thermal resistance has inverse relation with the coefficient of thermal conductivity. To find out the total resistance of the wall or ceiling, the collection of resistors for all materials should be included as well as the convection resistance adjacent to the external and internal surfaces. Dealing with these resistors exactly like that used with electrical resistors, they are either parallel or series. Resistance also called R-Value. It is worth noting that the US R-Value is about six times the SI R-Value due to the different standards.

Using the resistance concept,

$$R_1 = \frac{x_1}{k_1}$$

$$R_2 = \frac{x_2}{k_2}$$

in case of convection resistance,

$$R_c = 1/h$$

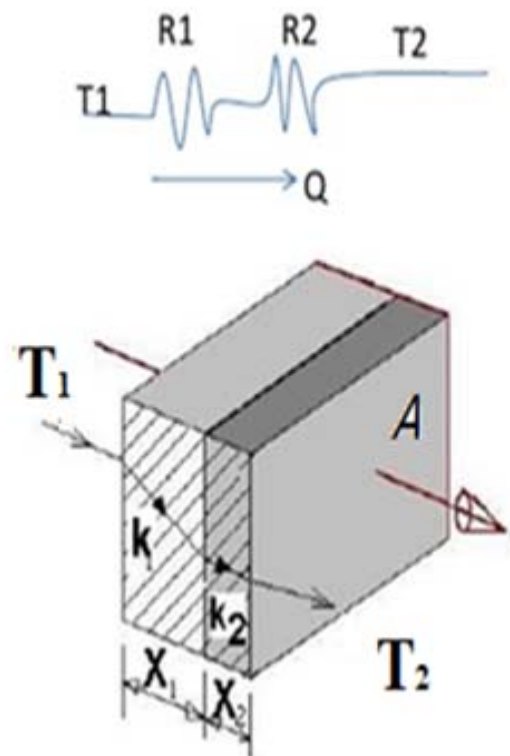

Fig. (2.6) Composite wall

Overall Heat Transfer Coefficient: it is a factor used to determine the optimum thickness of the insulation material in buildings. It is also called U-Value. And it can be calculated from the following relationship:

$$U = \frac{1}{R_1 + R_2}$$

Then calculate the amount of heat transfer through the wall by the following relationship:

$$Q = U A (T_1 - T_2)$$

Where T is the temperature of the surface and A is the surface area

The unit of U-Value is (W/m².K). The U-Value of uninsulated wall is high up (1-5), while the U-Value of insulated wall is less than (1), while for super-insulation wall is less than (0.2). The world is moving to standardize the U-Value for residential buildings as minimum as possible toward satisfying the zero energy building.

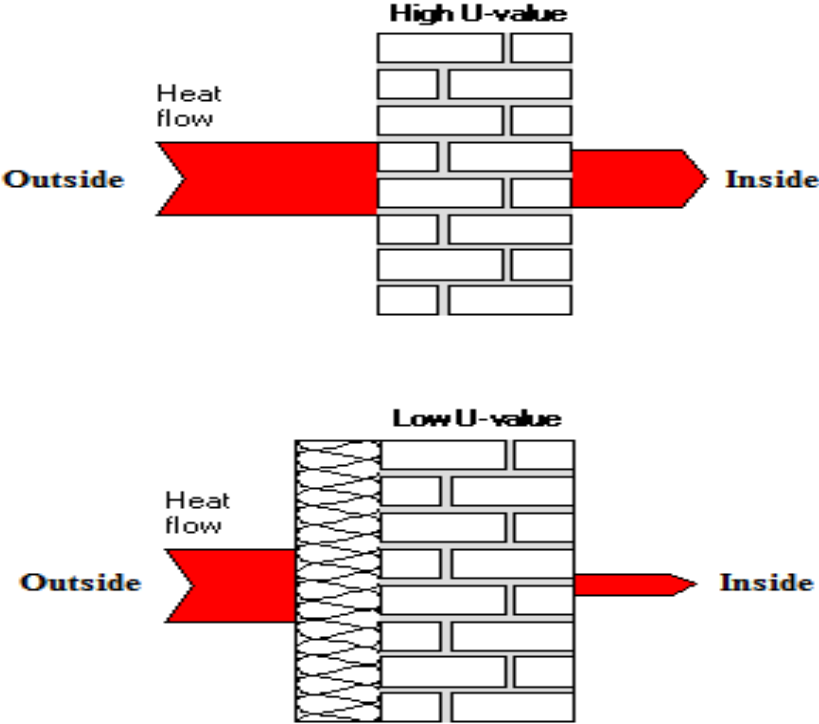

Fig (2.7) Effect of U-value in reducing the heat transfer

2.11 Engineering Calculations

These are some examples to show the effect of thermal insulation in energy conservation.

Example (1): Heat losses through the wall in the winter

Calculate the reduction in the amount of heat transmitted through the wall shown in the figure due to the insulation. The area of the wall is 1 m^2 and the coefficients of convection heat transfer are:

- $10 \text{ W/m}^2\cdot\text{K}$ for external surface

- $5 \text{ W/m}^2\cdot\text{K}$ for internal surface

Note: Values of thermal conductivity of the materials are taken from the tables.

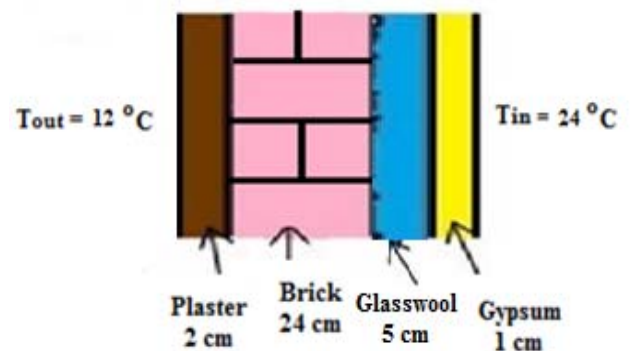

Solution:

- Before insulation

Plaster $R_1 = x_1/k_1 = 0.02/1 = 0.02$

Brick $R_2 = x_2/k_2 = 0.24/0.5 = 0.48$

Gypsum $R_3 = x_3/k_3 = 0.01/0.8 = 0.0125$

External air $R_o = 1/h_o = 1/10 = 0.1$

Internal air $R_i = 1/h_i = 1/5 = 0.2$

Total resistance $R = R_1 + R_2 + R_3 + R_o + R_i = 0.8125$

$U = 1 / R = 1.23 \text{ W/m}^2\cdot\text{K}$

$Q = U A (T_i - T_o) = 1.23 * 1 * (24 - 12) = 14.8 \text{ W}$

- After insulation

Glasswool $R_g = x_g/k_g = 0.05/0.04 = 1.25$

Total resistance $R = R_1 + R_2 + R_3 + R_o + R_i + R_g = 2.0625$

$U = 1 / R = 0.485 \text{ W/m}^2\cdot\text{K}$

$Q = U A (T_i - T_o) = 0.485 * 1 * (24 - 12) = 5.8 \text{ W}$

So the reduction in the heat loss $= (14.8 - 5.8)/14.8 = 0.608 = 61 \%$

Example (2): Calculation of the heat load in summer

Calculate the size of air-conditioning device (ton of refrigeration) required to cool a room of 6 m x 4m x 3m before and after the insulation. Note that the wall and the roof materials are shown in the figures below. Neglect the effect of radiation and convection heat transfer. Add 3000 W to the total load due to the heat gained through windows, ventilation, occupants and equipment.

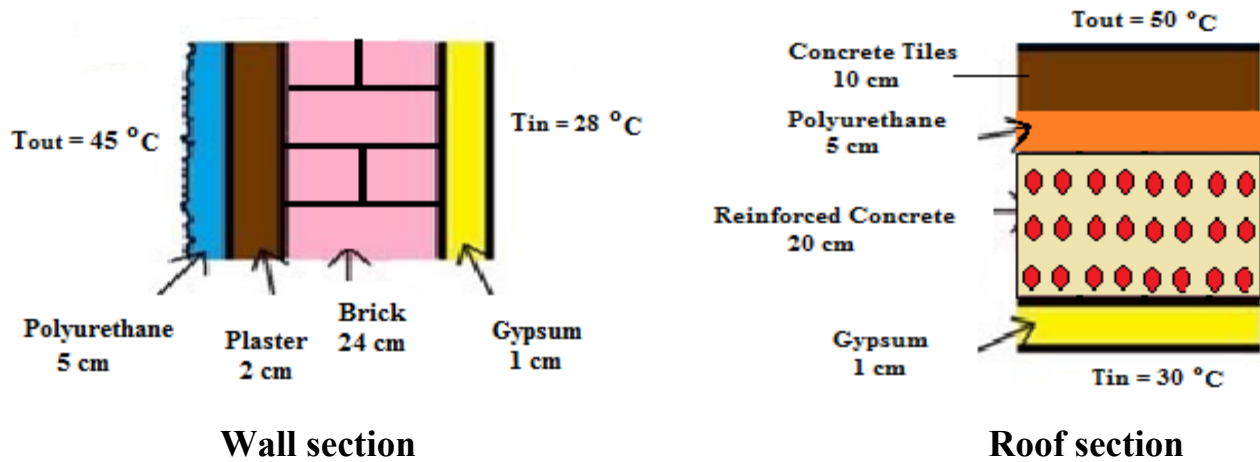

$$K_{\text{plaster}}=1, K_{\text{brick}}=0.5, K_{\text{gypsum}}=0.8, K_{\text{polyurethane}}=0.02, K_{\text{RC}}=2, K_{\text{concrete tiles}}=0.8$$

Solution:

• Before insulation

- Walls

$$\text{Plaster} \quad R_1 = x_1/k_1 = 0.02/1 = 0.02$$

$$\text{Brick} \quad R_2 = x_2/k_2 = 0.24/0.5 = 0.48$$

$$\text{Gypsum} \quad R_3 = x_3/k_3 = 0.01/0.8 = 0.0125$$

$$\text{Total resistance } R = R_1 + R_2 + R_3 = 0.5125$$

$$U = 1 / R = 1.95 \text{ W/m}^2 \cdot \text{K}$$

$$A = (6 \cdot 3 \cdot 2) + (4 \cdot 3 \cdot 2) = 60 \text{ m}^2$$

$$Q = U A (T_i - T_o) = 1.95 \cdot 60 \cdot (45 - 28) = 1990 \text{ W}$$

- **Roof**

Concrete tiles $R_1 = x_1/k_1 = 0.1/0.8 = 0.125$

Reinforced con. $R_2 = x_2/k_2 = 0.2/2 = 0.1$

Gypsum $R_3 = x_3/k_3 = 0.01/0.8 = 0.0125$

Total resistance $R = R_1 + R_2 + R_3 = 0.2375$

$U = 1 / R = 4.21 \text{ W/m}^2.\text{K}$

$A = 6*4 = 24 \text{ m}^2$

$Q = U A (T_i - T_o) = 4.21 * 24 * (50 - 30) = 2021 \text{ W}$

$Q_{\text{total}} = Q_{\text{walls}} + Q_{\text{roof}} + Q_{\text{others}} = 1990 + 2021 + 3000 = 7011 \text{ W}$

$\text{Load} = Q_{\text{total}} / 3500 = 7011 / 3500 = 2 \text{ TR}$

• **After insulation**

- **Walls**

Polyurethane $R_p = x_p/k_p = 0.05/0.02 = 2.5$

Total resistance $R = 0.5125 + 2.5 = 3.0125$

$U = 1 / R = 0.332 \text{ W/m}^2.\text{K}$

$Q = U A (T_i - T_o) = 0.332 * 60 * (45 - 28) = 338 \text{ W}$

- **Roof**

Polyurethane $R_p = x_p/k_p = 0.05/0.02 = 2.5$

Total resistance $R = 0.2375 + 2.5 = 2.7375$

$U = 1 / R = 0.365 \text{ W/m}^2.\text{K}$

$Q = U A (T_i - T_o) = 0.365 * 24 * (50 - 30) = 175 \text{ W}$

$Q_{\text{total}} = Q_{\text{walls}} + Q_{\text{roof}} + Q_{\text{others}} = 338 + 175 + 3000 = 3513 \text{ W}$

$\text{Load} = Q_{\text{total}} / 3500 = 3513 / 3500 = 1 \text{ TR}$

2.12 Electricity Demand Reduction

The use of insulation keeps the indoor temperature stable as well as reduces the thermal loads and thus the amount of electricity demand. It is usually account the electricity consumption in (kWh). In order to calculate the Annual Energy Demand (AED) use the following equation:

$$AED = Q_{total} * N / 100$$

Where N is the number of days under use

The amount of the annual consumption of electric power determines the building performance. The building performance factor could be calculated from the following relationship depending on the floor area:

$$BPF = AED / \text{Floor Area}$$

The building performance factor (BPF) is used to determine the type of building in terms of energy consumption, where high-energy building consumes more than (250 kWh/m²) per year while medium-energy building consumes an average between (100-200 kWh/m²) per year and low-energy building consumes less than (50 kWh/m²) per year.

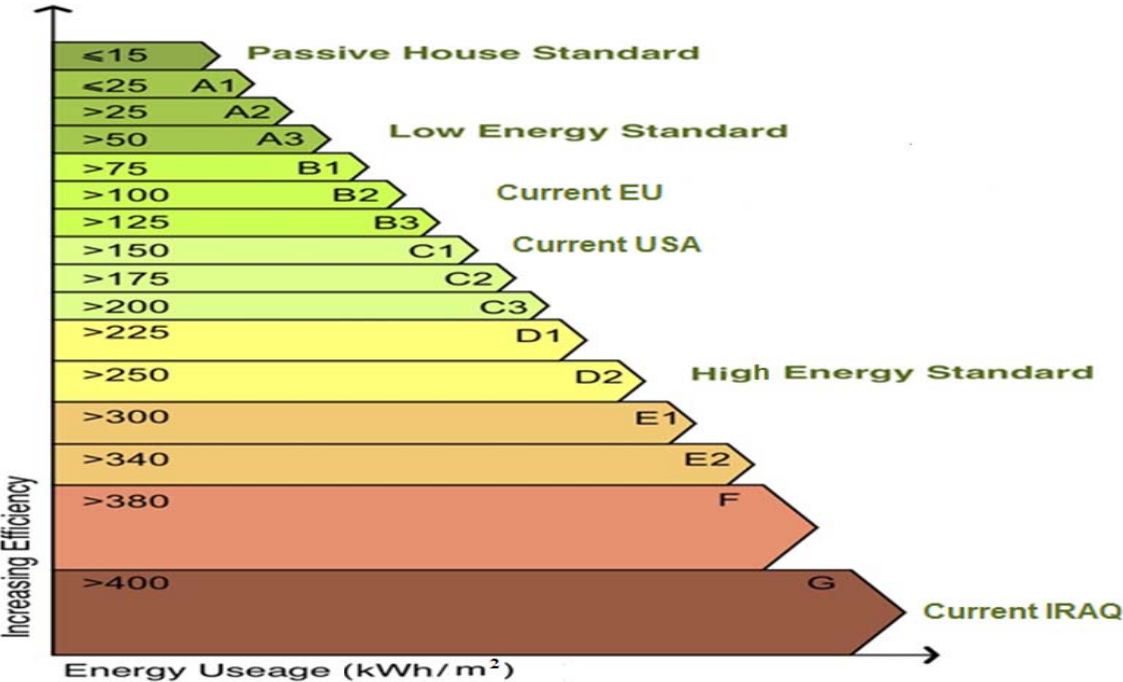

Fig (2.8) Energy classification standards

2.13 Reduce Oil Consumption

It is found that roughly about 3,000 liters of oil equivalent each year are burned to produce electricity for heating or cooling for uninsulated house. This could be saved up to 60% through the using of thermal insulation techniques. The approximate equation to determine the relationship between energy demand and the annual oil consumption in (liters/m²) of floor area is:

$$\text{Oil Consumption} = 1.5 * \text{Exp (BPF/120)}$$

2.14 Greenhouse Effect

Greenhouse gas is any compound gas in the atmosphere that is capable to absorb infrared and keeping the heat from escaping out of the atmosphere. Greenhouse gases are responsible of the phenomenon of global warming.

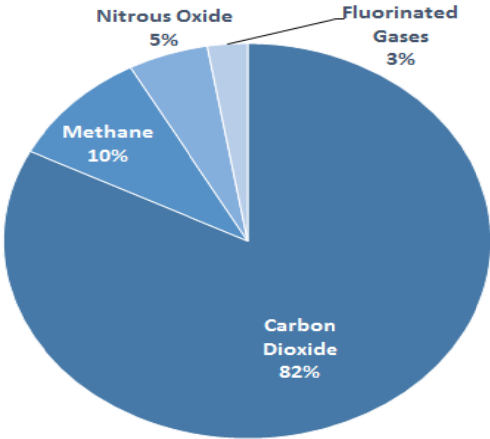

Fig. (2.9) Greenhouse gases

The sector of residential building has the major impact on the increase of greenhouse gases and it is considered as the most damage to the climate. The traditional house (non-insulated) causes the emission of more than 7,000 kilograms of carbon dioxide CO₂ into the atmosphere each year. The approximate equation to determine the relationship between energy demand and the annual CO₂ emission in (kg/m²) of floor area is:

$$\text{CO}_2 \text{ Emission} = 3.5 * \text{Exp (BPF/120)}$$

Example (3): Extra calculations for oil consumption and CO₂ emission

A house of 10 m x 5 m x 3 m dimensions has insulated walls and ceiling, as shown in the figure. Neglect the effect of radiation and convection heat transfer. Add 4000 W due to the heat gained through other sources. Calculate:

1. Total heat transmitted through the building.
2. Annual electricity consumption in the building as a result of cooling (Suppose the use of air-conditioning for 120 days).
3. Efficiency of the building.
4. Oil consumption in power plant as a result of the annual consumption.
5. CO₂ emissions in power plant.

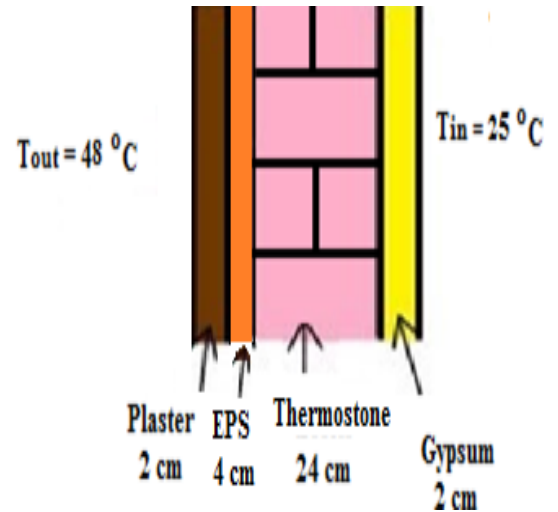

$K_{\text{plaster}}=1, K_{\text{EPS}}=0.05, K_{\text{thermostone}}=0.3, K_{\text{gypsum}}=0.8$

Solution:

1) Heat transfer

Plaster	$R1 = x1/k1 = 0.02/1 = 0.02$
EPS	$R2 = x2/k2 = 0.04/0.05 = 0.8$
Thermostone	$R3 = x3/k3 = 0.24/0.3 = 0.8$
Gypsum	$R4 = x4/k4 = 0.02/0.8 = 0.025$

Total resistance $R = R1 + R2 + R3 + R4 = 1.645$

$U = 1 / R = 0.608 \text{ W/m}^2\cdot\text{K}$

$A = (10*3*2) + (5*3*2) + (10*5) = 140 \text{ m}^2$ total area of walls and roof

$Q = U A (Ti-To) = 0.608 * 140 * (48-25) = 1957 \text{ W}$

2) Annual Electricity Demand

$Q_{\text{total}} = 1957 + 4000 = 5957 \text{ W}$

$\text{AED} = Q_{\text{total}} * N / 100 = 5957 * 120 / 100 = 7148 \text{ kWh}$

3) $\text{BPF} = \text{AED} / \text{Floor Area} = 7148 / 50 = 143 \text{ kWh/m}^2$ medium energy house

4) Oil Consumption = $1.5 * \text{Exp} (\text{BPF}/120) = 1.5 * \text{Exp} (143/120) = 5 \text{ liters/m}^2$

5) CO₂ Emission = $3.5 * \text{Exp} (\text{BPF}/120) = 12 \text{ kg/m}^2$

2.15 Thermal Images

Thermal images could be captured using thermal cameras like: FLIR, FLUKE and MSA. A thermographic image is used to illustrate the difference between the well and poorly insulation levels. Heat loss through the wall is highlighted by several colors. The amount of radiation emitted increases with temperature, therefore warm objects appears in red color against blue colors for cool objects.

Example: Thermal images of a building have been captured in the winter, as shown in the figure below. Explain your understanding.

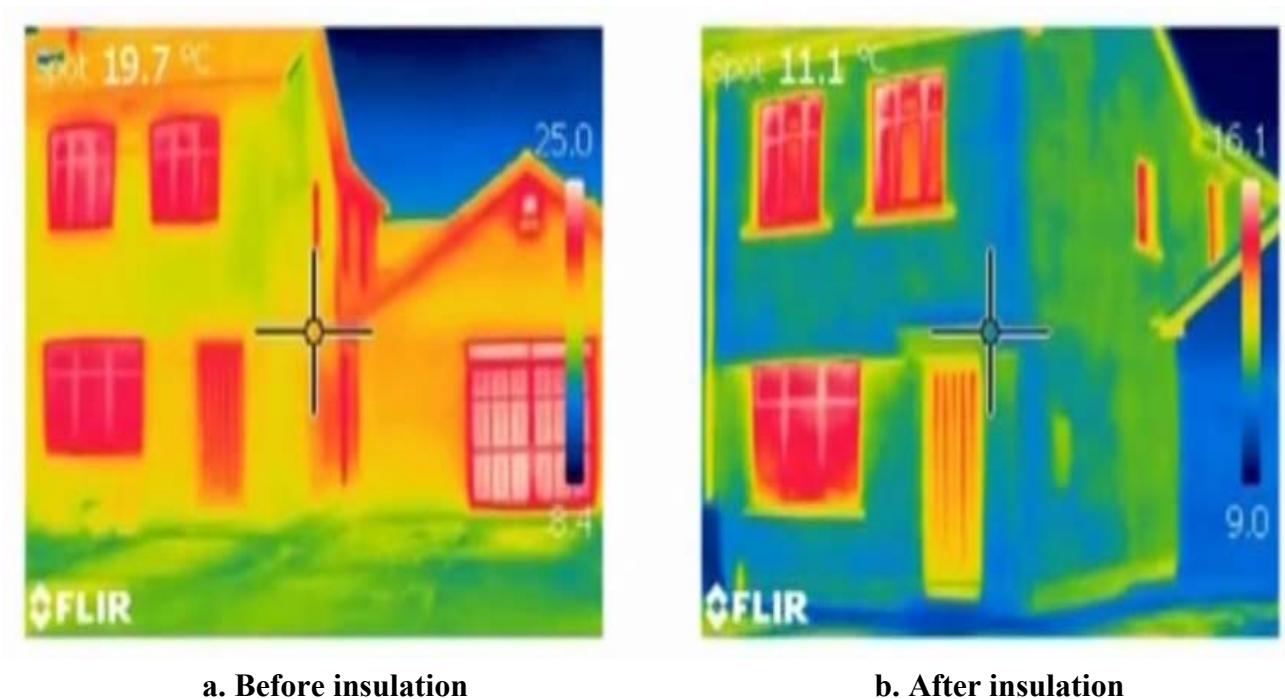

Answer: In image (a), where there is no insulation, heat is transferred easily through the walls and other building elements. Thus, the outer faces close to be red and yellow. On the other hand, in image (b) after insulation, heat is accumulated inside and the outer faces have the same ambient temperature, thus appeared in blue and green.

2.16 Economical Effect

The quality of the insulation materials are chosen to satisfy the requirements of good insulation and reduce energy consumption. To make the process more economical, thermal insulation of the building must be chosen carefully according to the following factors:

- The amount of insulation material and thickness.
- The cost of insulation material and labor costs, which will install it.
- The amount of energy that is saved to the building. Hence, the saved money.

The economical value of insulation equals to the cost of the insulators minus the cost of air-conditioning units that is saved for a certain period. It has found that super insulation of the building increases the cost of construction up to 20%, but this amount would be recovered as a result of lower electricity bills in a few years. Some countries encourage the low-energy homes by exempting the electricity bills. The costs of some insulators are shown in the table below.

Table (2.8) Average costs of some common insulators

Item	Insulation Material	Cost (\$/m ²) for each cm thickness
1	Alucobond	20
2	Asbestos	8
3	Asphalt	2
4	Cellulose	1.5
5	Cement	6
6	Clay	0.7
7	Coal	2
8	Cotton	3
9	Cork (EPS)	1.5
10	Glass Fiber	2.5
11	Glass Wool	2.5
12	Gypsum Plaster	3
13	Perlite	4
14	Polystyrene	3
15	Polyurethane	6
16	Rubber	2
17	Wood	15
18	Wool	8
19	Granite	18
20	GRC	10
21	Limestone	12
22	Sandstone	12
23	Marble	18
24	Basalt	12

2.17 Useful Applications

There are some tools used to obtain the contribution of thermal insulation to energy saving, fuel consumption and CO₂ emissions. The course included 2 computer-lab hours for the certain applications:

- **Iraqi Passive House Planning Package (IPPP):** It is a visual basic based design tool that is used to find complete energy balance of passive or active buildings in Iraq. The application is very responsible for the hot climate zone of Iraq. It includes the following features:
 - Meteorological data (18 cities in Iraq)
 - Properties library for different construction materials and insulations
 - Cooling and heating load calculation for residential building
 - Electricity power consumption
 - Contribution of renewable energy
 - Indoor air quality and ventilation system
 - Passive house standards verification
 - Oil consumption
 - CO₂ emission
 - Cost analysis

Iraqi Passivhaus Planning Package (IPPP)
Heat Transfer Behavior and Air-conditioning Load Required for House in Iraq

City: Latitude (N): Longitude (E): Elevation (m):

Meteorological Data

	Summer	Winter
Radiation (W/m ²)	<input type="text" value="900"/>	<input type="text" value="250"/>
Outdoor Temp. (C)	<input type="text" value="46"/>	<input type="text" value="9"/>
Relative Humidity (%)	<input type="text" value="27"/>	<input type="text" value="75"/>
Wind Speed (m/s)	<input type="text" value="3"/>	<input type="text" value="3.5"/>
Earth Temp. (C) at 0.3 m	<input type="text" value="36"/>	<input type="text" value="13"/>

Dimensions of Building

Length (m): Width (m): Height (m):

Type of Calculation

Cooling Heating

Structure

- Walls
- Roof and Floor
- Window and Door
- Thermal Bridge
- Ventilation System

Building Performance

- Cooling Load
- Passivhaus Evaluation
- Cost Analysis

Diagram Labels: Solar PV, double glazing, Super insulation, Wastewater heat exchanger, Ground cooling, Air out, Air In

Fig. (2.10) Main form of Iraqi Passive House Planning Package

- **RETScreen:** is a clean energy management software system for energy efficiency, renewable energy and cogeneration project feasibility analysis as well as ongoing energy performance analysis. RETScreen 4 is an Excel-based clean energy project analysis software tool that helps to determine the technical and financial viability of potential clean energy projects. The application includes the following features:

- **Energy efficiency (EE)** models for residential, commercial & institutional buildings, & for industrial facilities & processes
- **Climate database** expanded to **4,700 ground-stations & NASA Satellite Dataset Integrated** within the software to cover populated areas across the entire surface of planet
- Renewable energy, cogeneration & EE models integrated into **one software file** & emerging technologies, such as wave & ocean current power added
- **Project database** providing users instant access to key data and information for hundreds of case studies & project templates
- **RETScreen file format (*.ret)** - a dramatically smaller file size (<25 KB instead of 10 MB) that is easily shared over the Internet & which allows the user to create custom databases for RETScreen
- **Software & databases translated into 35 languages** that cover 2/3 of the world's population, and available at the click of the mouse

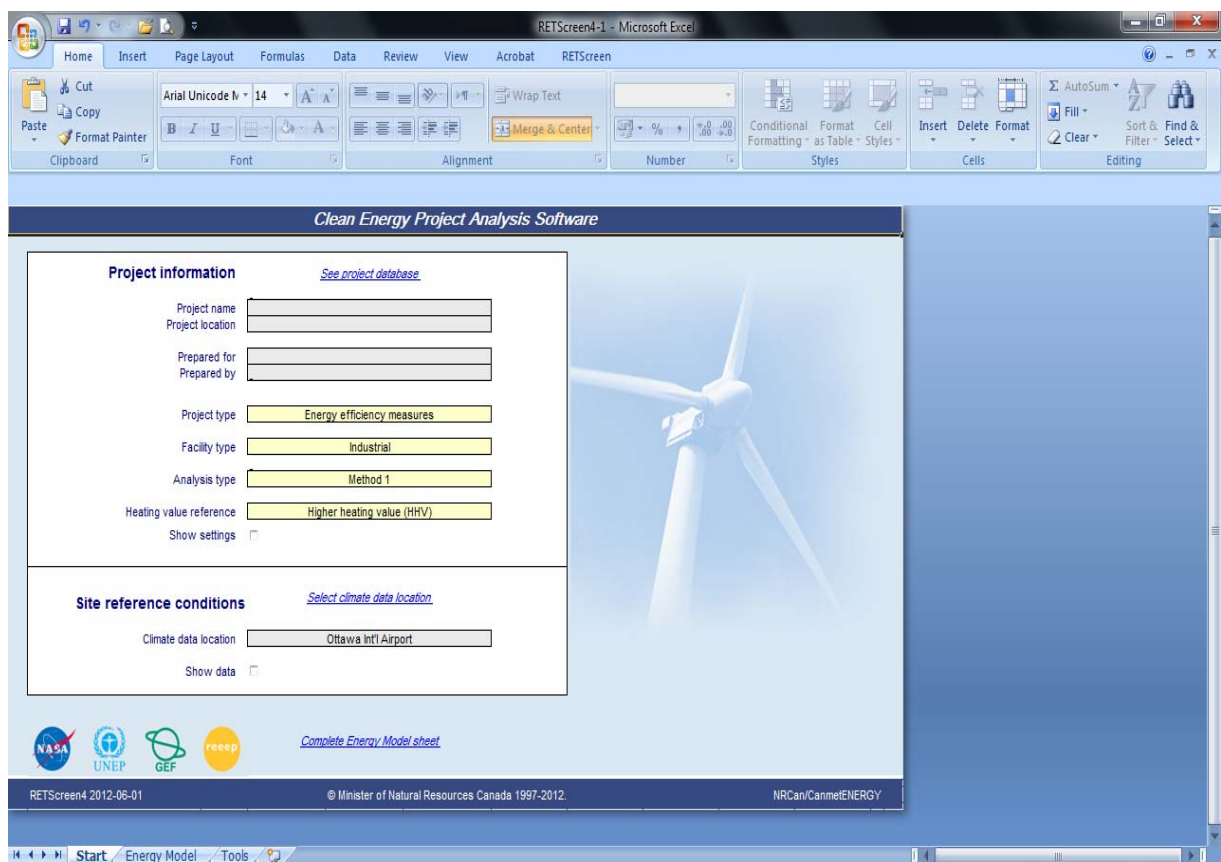

Fig. (2.11) Main form of RETScreen

- More information are available on the site: <http://www.retscreen.net/>

Chapter Three

Acoustic Insulation

Chapter Three

Acoustic Insulation

3.1 Acoustic Insulation

Acoustic insulators are those materials that prevent sound transmission or absorb it. Sound is transmitted in form of pressure waves through the air where we can distinguish various voices as well as the noise. Sound travels also through solid objects. The continuous sounds surrounding mankind may lead to nervous tension and affect the behavior and action of people. Therefore, environmental engineering identified appropriate sound levels for living and working. Since, it is easy of sound transmission through concrete parts, thus, it should always control the design of the building and select the most appropriate soundproofing materials. The insulation of building prevents the transmission of sound outside or inside and from room to another.

3.2 Architectural Procedures to Control the Acoustics

1. Planning methods of determining the home position relative to sources of external sounds such as streets, markets and factories as well as the correct orientation of windows, doors, etc.
2. Design methods for internal spaces of the building.
3. Methods of choosing perfect soundproofing material.

3.3 Objective of Acoustic Insulation

1. Prevent transmission of sound from the outside.
2. Prevent transmission of sound between the rooms through walls and ceilings.
3. Prevent the transmission of sounds and vibrations of machines.
4. Absorption of sound inside.

3.4 Procedures of Acoustic Insulation

1. Walls: Using wall tiles and insulating materials such as cork, glass wool and polyurethane foam.
2. Roof: using insulators such as plastic sheets, secondary or ceiling panels, perlite and vermiculite.
3. Dampers: some rubbers, fiberglass or certain panels could be placed under vibrating machines or inside the room. The pieces of furniture help to absorb amount of sounds.
4. Avoid acoustic bridge: it is a term describes the region that allows the transmission of sound a result of the damage in insulator or in case of absence it basically. One of these areas is the joint link between the walls and the ceiling or between the walls and floor slabs.

3.5 Classification of Acoustic Insulators

The incident sound upon a surface could be distributed into three main parts. The first part is reflected from the surface, the second part is absorbed by the surface while the last part is transmitted across the surface to inside. So it could say that the sound-proofing materials are divided into:

1. Reflective materials
2. Absorbing material

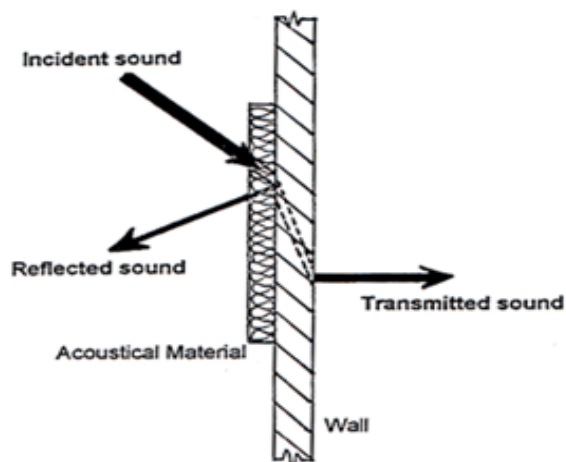
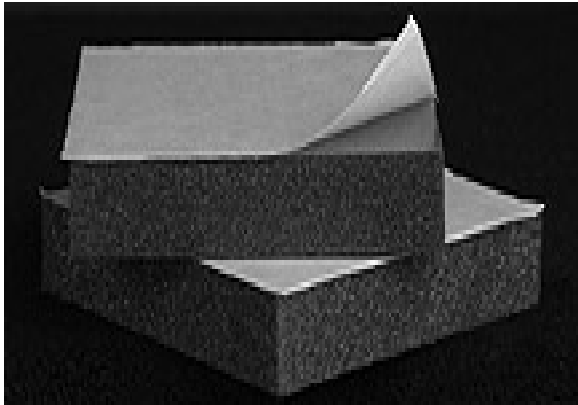

Fig. (3.1) Distribution of sound

3.6 Commercial Insulators

1. Acoustic tiles, these tiles have the capability of sound absorption, durability and ease of cleaning. Often, they are made of composite materials such as quartz mixed with granular resin, as well as the fiberglass, that results from the mixing of glass wool with epoxy. These tiles are used for the absorption of sounds of machines.
2. Glass wool or rock wool, they are characterized by the ability to absorb sound and thermal insulation, and can be mounted on the walls and ceiling. These could be used in commercial and industrial buildings.
3. Polyurethane foam which are available in the form of spray, layers and tiles.
4. Cellulose panels which are compressed and perforated face.
5. Gypsum boards with the addition of fibers to the surface.
6. Rubber in many forms natural rubber panels, industrial chloroprene (neoprene or polychloroprene) and layers of Mass Loaded Vinyl (MLV). These are available in panels and rolls and they have high sound absorption and they are used to cover the walls, as well as to absorb vibrations.
7. Natural cork or synthetic cork (EPS).
8. Plastic packaging sheets: these layers fit for ceilings in factories where large dimensions. These are resistant to dust as well as the moisture.
9. Perlite, a white color substance taken from the volcanic rocks, and it is a good insulator of sound and heat. It gives the surface a reliable fire-resistant. Perlite is used to insulate the ceiling, walls and floors.
10. Viscoelastic damping compound (VDC), a viscous resin fast to dry, used in flooring damping, absorption of the noise as well as to absorb the vibrations of machinery and ducts.
11. Fabrics, leather, carpet and sponge materials.
12. Metallic panel, it is similar in work to the silencer where it dissipates the undesired sounds and then absorbs it by acoustic insulation inside (fiberglass).



Polyurethane, 5 cm, 32 kg/m³, NRC=0.9



Rock wool, 5 cm, 60 kg/m³, NRC=0.7



Acoustic tiles (Quartz, 1250 kg/m³)



Metallic panel



Fiberglass (48 kg/m³)



Mass Loaded Vinyl (16 kg/m³)

Fig. (3.2) Sound insulators

3.7 Acoustical Engineering

Sound: it is a kind of mechanical energy. Sound travels from one place to another in the form of pressure waves occurring vibrations in the air or building materials. And it can distinguish between sounds by ear or audio devices. The sound does not move in a vacuum but only in a medium. The science of acoustics describes the source of the sound, its transmission and sensing of it.

There are some basic definitions in acoustics science, including:

Type of sound: it is the property that distinguishes between different types of sounds. For example, the voice of a man, an animal, a machine, etc.

Quality of sound: it is the property that characterized the pitch change to the same source. it depends on the frequency of sound waves which characterized the loudness of sounds, such as the difference between the sound of men and women and the difference between mature and young voices, as well as sound in joy and sorrow.

Sound intensity: it is the property that differentiates between sounds in terms of being high or low.

Sound frequency: it is the number of times that air particles fluctuate per second as a result of sound energy passed. It is expressed in the unit of Hertz (Hz). Most of the sounds that we hear are a mixture of frequencies.

Classification of sound waves

1. Infrasonic: waves that have less than 20 Hz frequency.
2. Sonic: waves that have frequencies between 20 Hz and 20,000 Hz.
3. Ultrasonic: waves that have frequencies above 20,000 Hz.

Sound power: it is the energy carried by the acoustic wave in a period of time. And it is measured in watts.

Sound intensity: mathematically, it is the amount of acoustic energy on a unit area. Human ear can feel a sound has 10^{-12} W/m² intensity as minimum. The highest intensity of sound within earshot is 1 W/m².

$$I_{\text{ref}} = 10^{-12} \text{ W/m}^2$$

Sound Intensity Level (SIL): The sound intensity value is too small and it is difficult to compare with, so it is looking for a value more acceptable like (Decibel) which is symbolized by (dB). The lowest sound level value is zero dB. The sound level could be accounted from the relation:

$$\text{SIL} = 10 \log (I/I_{\text{ref}})$$

Based on that, the sound is classified in terms of the level of intensity to:

- 0 - 40 dB : Quiet
- 40 - 80 dB : Noisy
- 80 - 120 dB : Very noisy
- > 120 db : Intolerable

Sound pressure: It is the change of atmospheric pressure in a region as a result of the passage of sound. The less sound pressure feeling by human ear is about 2×10^{-5} Pa and this is called the hearing threshold. At a pressure of about 20 Pa the ear starts feeling of pain.

$$P_{\text{ref}} = 2 \times 10^{-5} \text{ Pa}$$

Sound Pressure Level (SPL): it is a value similar to the sound intensity level, and also measured in decibels. It is calculated from the relation:

$$\text{SPL} = 20 \log (P/P_{\text{ref}})$$

Table (3.1) Properties of some sound sources.

Sound sources (noise) Examples with distance	Sound pressure Level L_p dB SPL	Sound pressure p $N/m^2 = Pa$ Sound field quantity	Sound intensity I W/m^2 Sound energy quantity
Jet aircraft, 50 m away	140	200	100
Threshold of pain	130	63.2	10
Threshold of discomfort	120	20	1
Chainsaw, 1 m distance	110	6.3	0.1
Disco, 1 m from speaker	100	2	0.01
Diesel truck, 10 m away	90	0.63	0.001
Kerbside of busy road, 5 m	80	0.2	0.000 1
Vacuum cleaner, distance 1 m	70	0.063	0.000 01
Conversational speech, 1 m	60	0.02	0.000 001
Average home	50	0.006 3	0.000 000 1
Quiet library	40	0.002	0.000 000 01
Quiet bedroom at night	30	0.000 63	0.000 000 001
Background in TV studio	20	0.000 2	0.000 000 000 1
Rustling leaves in the distance	10	0.000 063	0.000 000 000 01
Hearing threshold	0	0.000 02	0.000 000 000 001

3.8 Sound Transmission

It means the ability of sound to move across the building from one part to another. There are several ways for sound moving which are:

- Airborne transmission: it referred to the sound transmitted through windows and openings. These can be processed by good sealing.
- Impact transmission: It means the voices of people movement as well as of the machines on the upper floor. These can be treated by absorbing layers and dampers such as carpet and rubber.
- Flanking transmission: It means the sound transmission through the parts of the building (concrete, metal, wood or glass). These are processed using insulating materials. Any part of the building has a number represents the amount of resistance to the permeability of sound which is called (Transmission Loss).

Transmission loss

It is a measure of the sound difference in decibels through the barrier. For example, if we have a sound of 100 decibels on a side of the wall. Then we measured this sound on the other side and we found it is 55 dB. Then we say that the wall has 45 dB transmission loss. The higher value indicates good resistance and good acoustic insulation. This value varies depending on the frequency of the sound source.

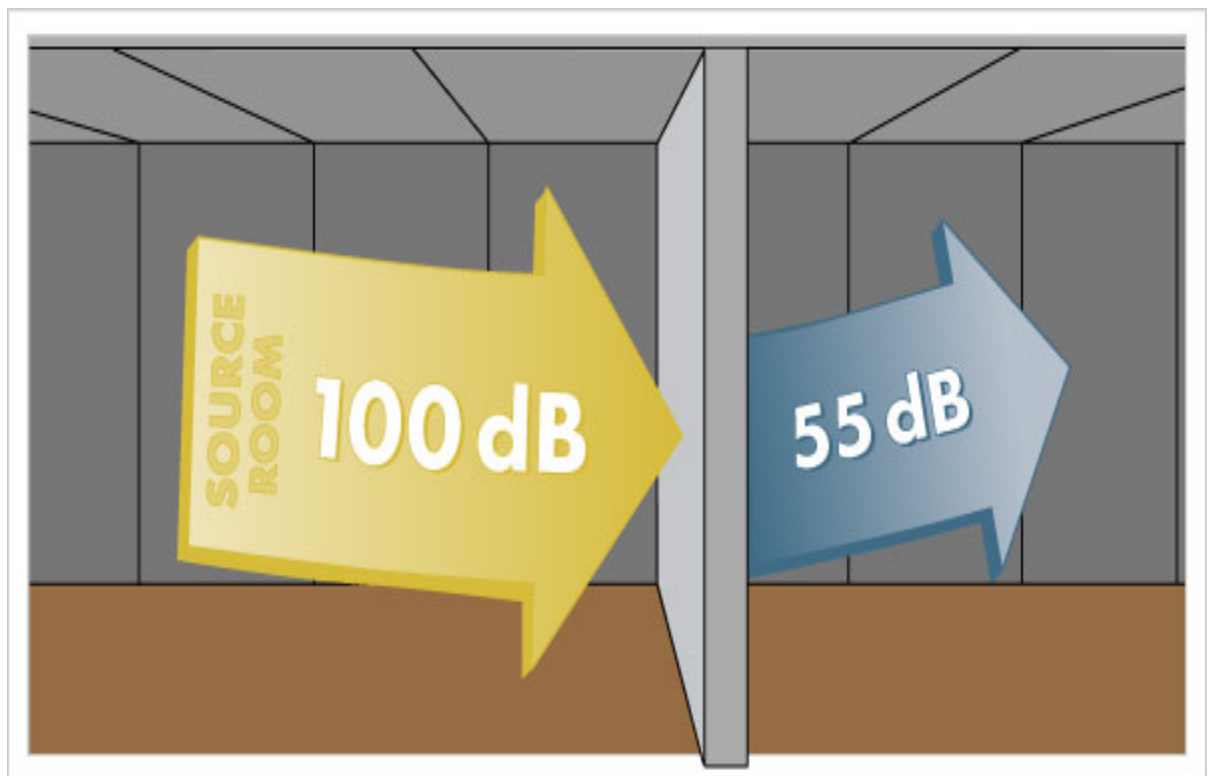

Fig. (3.3) Transmission loss

Sound Transmission Class (STC)

It is the amount of transmission loss through a barrier or a wall at a sound frequency of 500 Hz. Sound transmission class is a key factor in the design and represents an indication of the building element performance to resistance the sound transmission through it.

Table (3.2) STC values of some building elements

Partition type	STC
Single glass window	27
Double glass window	30
Single layer of 1 cm drywall on each side, wood studs, no insulation (typical interior wall)	33
Single layer of 1 cm drywall on each side, wood studs, fiberglass insulation	39
10 cm hollow CMU (Concrete Masonry Unit)	44
20 cm thermostone wall with plastering for both sides	44
Double layer of 1 cm drywall on each side, wood studs, batt insulation in wall	45
Single layer of 1 cm drywall, glued to 15 cm lightweight concrete block wall, painted both sides	46
15 cm Hollow CMU (Concrete Masonry Unit)	46
20 cm hollow CMU (Concrete Masonry Unit)	48
25 cm hollow CMU (Concrete Masonry Unit)	50
20 cm hollow CMU (Concrete Masonry Unit) with 5 cm Z-Bars and 1 cm drywall on each side	52
20 cm concrete floor with plastering for both sides	53
Single layer of 1 cm drywall, glued to 20 cm dense concrete block wall, painted both sides	54
20 cm hollow CMU with 5 cm wood Furring, 5 cm fiberglass insulation and 1 cm drywall on each side	54
24 cm brick wall with plastering for both sides	54
Double layer of 1 cm drywall on each side, on staggered wood stud wall, batt insulation in wall	55
Double layer of 1 cm drywall on each side, on wood stud wall, batt insulation	59
Double layer of 1 cm drywall on each side, on wood/metal stud walls (1 cm space), double batt insulation	63
20 cm Hollow CMU with 8 cm Steel Studs, fiberglass Insulation and 1 cm drywall on each side	64
20 cm concrete block wall with 1 cm drywall on steel stud walls, each side, insulation in cavities	72

3.9 Sound Absorption

Any substance has the ability to absorb sound in addition to its ability to reflect the sound. The energy absorbed is converted into heat. Sound absorption factor is a value describes the ability of sound absorption. The absorbance in porous materials is more than in dense solids.

Coefficient of sound absorption: It is the ratio between the energy absorbed by the surface to the total energy incident up on the surface. The parameter is denoted by the symbol (α).

Table (3.3) Coefficients of sound absorption at different frequencies

Material	Frequency (Hz)					
	125	250	500	1,000	2,000	4,000
Acoustic Panels	0.15	0.3	0.75	0.85	0.75	0.4
Brick	0.024	0.024	0.03	0.04	0.05	0.07
Carpet	0.05	0.1	0.3	0.25	0.3	0.35
Concrete	0.01	0.01	0.02	0.02	0.02	0.03
Curtains	0.05	0.12	0.15	0.27	0.37	0.5
Fiberglass	0.38	0.89	0.96	0.98	0.81	0.87
Wood Floor (joists)	0.15	0.2	0.1	0.1	0.1	0.05
Glass	0.03	0.03	0.03	0.03	0.02	0.02
Gypsum board	0.3	0.1	0.05	0.04	0.07	0.1
Plaster	0.3	0.3	0.1	0.1	0.04	0.02
Plywood on 2" Batten	0.35	0.25	0.2	0.15	0.05	0.05
Wood Panel	0.1	0.11	0.1	0.08	0.08	0.11

Note:

It can be seen from the table above that the absorption coefficient of the material varies with the source frequency. In some cases, taking the average of these values is preferred and this is what so-called **Noise Reduction Coefficient (NRC)** which is commonly used to describe the value of the absorbance of the insulating material.

Table (3.4) Noise reduction coefficient of some insulating materials

Material	NRC
Acoustic tiles	0.8-0.9
Polyurethane	0.8-0.9
Mass vinyl	0.75
Glass wool	0.7
Asbestos	0.6
Mineral wool	0.65
EPS, XPS	0.3-0.4
Rubber	0.2

Absorption capacity: it represents the amount of acoustic units that can be absorbed by the barrier or the wall. Sound absorption unit is called (Sabin). The absorption capacity depends on the space area and absorption coefficient according to the relationship:

$$C = \alpha \times A$$

3.10 Noise Reduction (Attenuation)

The total amount of reduction in the acoustic energy as a result of reflection and absorption when moving from a room to another or abroad is called the noise reduction. This amount is expressed in the relationship:

$$NR = TL + 10 \text{ Log } (C/A)$$

Where: TL is the loss transmission of the walls

C is the absorption capacity of the room

A is the area of the separation wall

Note: in the design usually suppose a sound frequency value of 500 Hz which is still within the range of the voices of people and cars, as shown in the figure below.

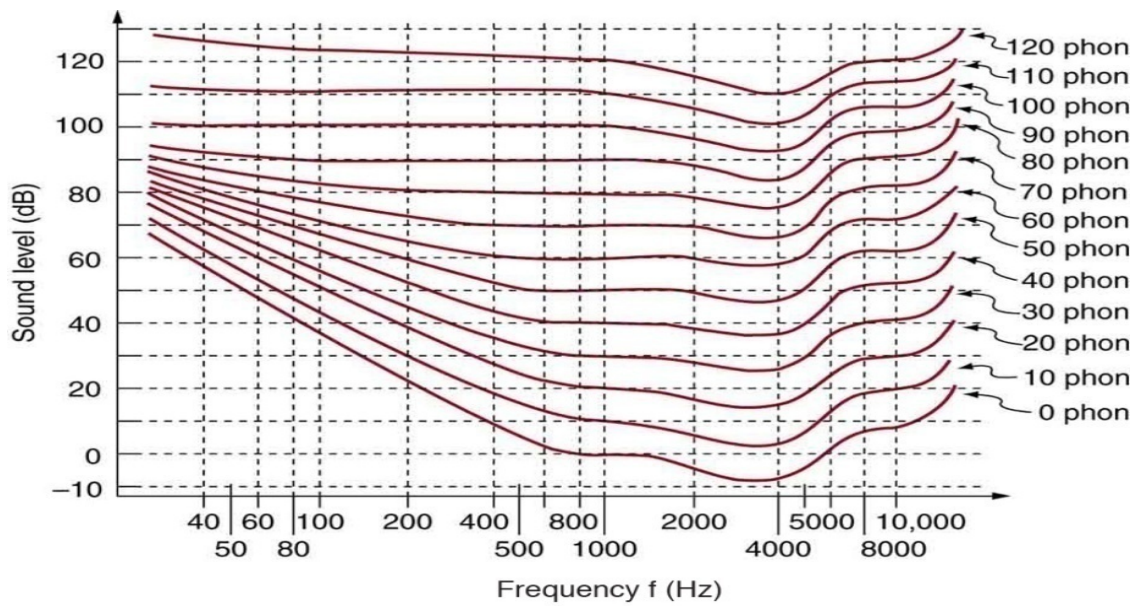

Fig. (3.4) Relation between sound level and frequency

- So it could say that:

$$TL = STC$$

- In case of high ranges of frequencies, then it is acceptable to use the correction chart as shown in the figure below.

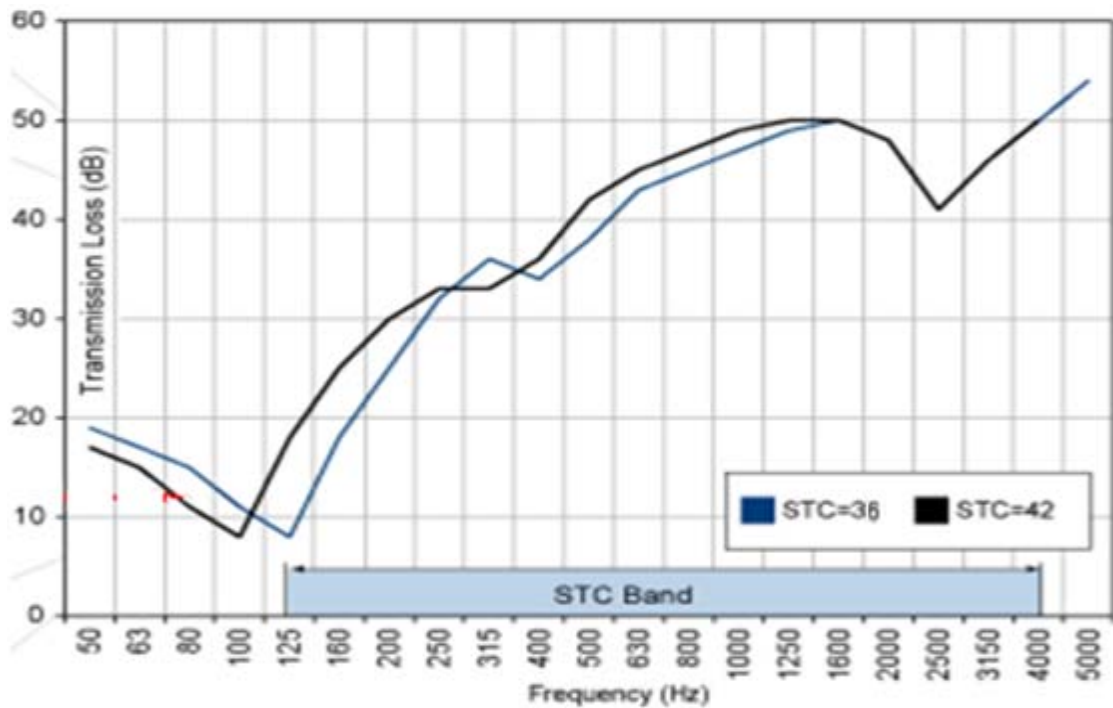
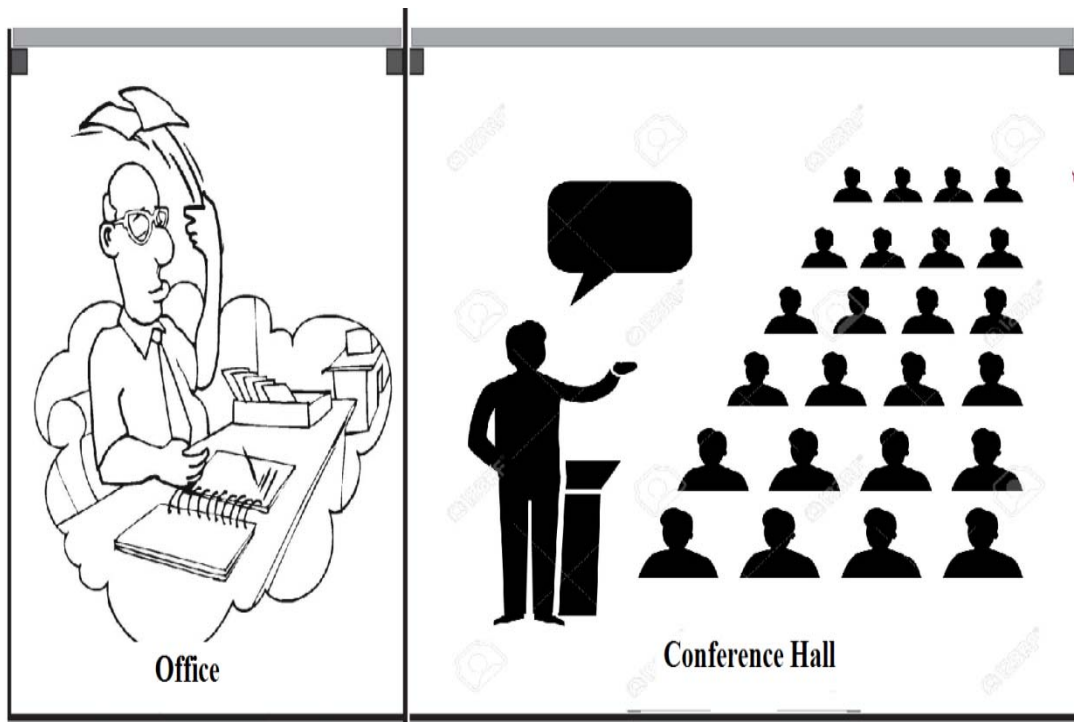

Fig (3.5) Correction of STC value at many sound frequencies

3.11 Engineering Calculations

Here are some examples to show the effect of acoustic insulators.

Ex. (1) A conference hall of 10 m x 6 m x 3.5 m, has 3 walls of gypsum ($\alpha=0.05$), one facade of glass ($\alpha=0.03$), ceiling of plastic tiles ($\alpha=0.1$) and floor of carpet ($\alpha=0.3$). An office is located next door to the hall, as shown in the figure.



Find:

- Total absorption for the conference hall. (Absorption of furniture=20 Sabins)
- Noise reduction for the office room. (STC of the separated wall is 48)
- Total absorption for the conference hall if the separated wall is covered by acoustic tiles (NRC=0.9)
- Noise reduction for the office room after insulation. (STC of the separated wall becomes 54)

Solution

a)

- Walls (gypsum) $A = 10 \times 3.5 + 6 \times 3.5 \times 2 = 77 \text{ m}^2$
 $C = \alpha \times A = 0.05 \times 77 = 4 \text{ Sabins}$
- Wall (glass) $A = 10 \times 3.5 = 35 \text{ m}^2$
 $C = \alpha \times A = 0.03 \times 35 = 1 \text{ Sabin}$
- Ceiling (plastic tiles) $A = 10 \times 6 = 60 \text{ m}^2$
 $C = \alpha \times A = 0.1 \times 60 = 6 \text{ Sabins}$
- Floor (carpet) $A = 10 \times 6 = 60 \text{ m}^2$
 $C = \alpha \times A = 0.3 \times 60 = 18 \text{ Sabins}$

$$C_{\text{total}} = C_{\text{walls}} + C_{\text{ceiling}} + C_{\text{floor}} + C_{\text{furniture}} = 4 + 1 + 6 + 18 + 20 = 49 \text{ Sabins}$$

$$\text{b) } NR = TL + 10 \text{ Log } (C/A) = 48 + 10 \text{ Log } (49/21) = 52 \text{ dB}$$

- c) Acoustic tiles $A = 6 \times 3.5 = 21 \text{ m}^2$
 $C = NRC \times A = 0.9 \times 21 = 19 \text{ Sabins}$

$$C_{\text{total}} = 49 + 19 = 68 \text{ Sabins}$$

$$\text{d) } NR = TL + 10 \text{ Log } (C/A) = 54 + 10 \text{ Log } (68/21) = 60 \text{ dB}$$

It is an excellent insulation.

Ex. (2) A living room of 6 m x 5 m x 3 m has the following features:

<u>Element</u>	<u>Material</u>	<u>α</u>
Walls	Plywood	0.2
Ceiling	Gypsum	0.05
Floor	Carpet	0.3

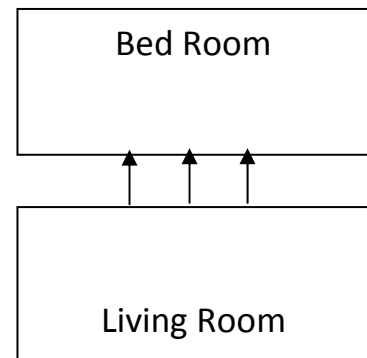

What would be the noise attenuation with respect to the upper bed room for:

1- Before insulation.

2- After insulating the ceiling by 5 cm glasswool (NRC=0.7).

Take into account that STC of the roof without insulation is (48) and with insulation is (54). There is an additional absorption due to the furniture (15 Sabins).

Solution

1-Befor insulation

- Walls (plywood) $A = 6*3*2+5*3*2 = 66 \text{ m}^2$

$$C = \alpha \times A = 0.2*66 = 14 \text{ Sabins}$$

- Ceiling (gypsum) $A = 6*5 = 30 \text{ m}^2$

$$C = \alpha \times A = 0.05*30 = 2 \text{ Sabins}$$

- Floor (carpet) $A = 6*5 = 30 \text{ m}^2$

$$C = \alpha \times A = 0.3*30 = 9 \text{ Sabins}$$

$$C_{\text{total}} = C_{\text{walls}} + C_{\text{ceiling}} + C_{\text{floor}} + C_{\text{furniture}} = 14+2+9+15 = 40 \text{ Sabins}$$

$$NR = TL + 10 \text{ Log } (C/A) = 48 + 10 \text{ Log } (40/30) = 50 \text{ dB}$$

2-After insulation

- Glasswool $A = 6*5 = 30 \text{ m}^2$

$$C = \text{NRC} \times A = 0.7*30 = 21 \text{ Sabins}$$

$$C_{\text{total}} = 40+21 = 61 \text{ Sabins}$$

$$NR = TL + 10 \text{ Log } (C/A) = 54 + 10 \text{ Log } (61/30) = 57 \text{ dB}$$

Very good insulation.

Ex. (3) A generator is located outdoor a warehouse (10 m away), and beside the external wooden door, as shown in the figure below. Measuring of sound level during the running of the generator gives (90 dB). Neglect the sound transmission across the walls.

1. Find the noise reduction across the door to the inside without insulation. Absorption of sound by the atmosphere is (0.5 dB/m).

2. What would be the thickness of the insulator in order to achieve (35 dB) inside.

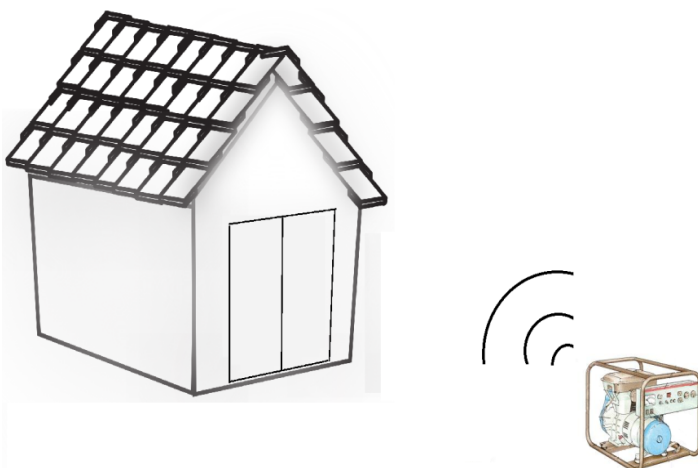

Type	Description	STC
A	Door without insulator	20
B	Door with 5 mm insulator	30
C	Door with 10 mm insulator	40
D	Door with 15 mm insulator	50
E	Door with 20 mm insulator	60

Solution:

1) Before insulation

$$\text{Absorption by the atmosphere} = 0.5 \times 10 = 5 \text{ dB}$$

From the table choose STC = 20

$$\text{NR} = \text{TL} + \text{Absorption} = 20 + 5 = 25 \text{ dB}$$

2) After insulation

$$\text{NR} = 90 - 35 = 55 \text{ dB}$$

$$\text{TL} = \text{NR} - \text{Absorption} = 55 - 5 = 50 \text{ dB}$$

From the table choose Type (D), so the thickness of insulator is (15 mm).

3.12 Noise Pollution in Industrial

The steady increase in the noise level result in a permanent damage in the auditory system, as well as some attendant symptoms like: reducing the heart rate, changing in blood pressure and difficulty of breathing. As the psychological impact on the individual worker, protrudes through the change the style of his sleep, thus accompanying fatigue in the body which will affect the production efficiency of the working. If the worker is exposed to a continuous noise (80 dB) during the period of his work, then that will lead to loss 15 dB approximately in his hearing threshold during several years (i.e., he loses the level of whisper).

The sound level is measured using a device called sound level meter, as shown in the figure below.



Fig (3.6) Sound level meter

The prevention of noise pollution satisfying the industrial safety conditions required in the lab, factory and warehouse. So, it must follow these steps:

1. Use suitable damper for high-vibration machines.
2. Use soundproofing for the purpose of absorption and dispersion of sounds.
3. Use of ear protectors as a prerequisite for workers.



Vibration pad (Neoprene or vinyl)



Viscoelastic compound



Noise Control Baffles (fiberglass)



Curtain

Fig. (3.7) Noise dampers

Example: Noise control baffles of fiberglass are used to reduce the overall noise level in an industrial plant (80' L x 40' W x 20' H), and they are suspended above the noise source, as shown in the figure below. The walls and ceiling are concrete, while the floor is carpet. Estimate the number of baffles for noise reduction of 8 dB. Use the nomogram.

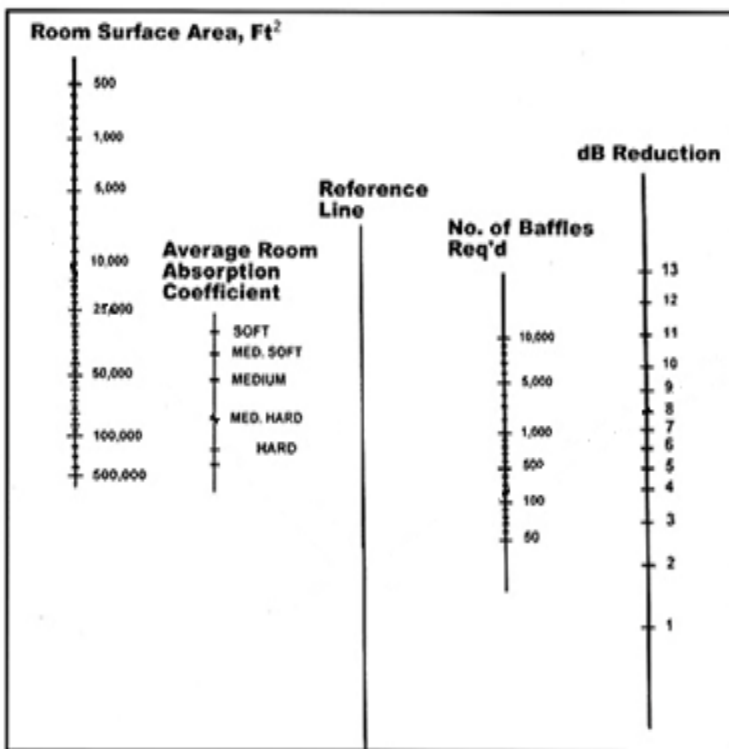

Nomogram

Term	Description
Hard	6 hard surfaces
Med. Hard	5 hard surfaces and 1 absorptive
Medium	4 hard surfaces and 2 absorptive
Med. Soft	3 hard surfaces and 3 absorptive
Soft	2 hard surfaces only or even one

Hard surface like: concrete, brick, marble and gypsum. Absorptive surface like: wood and carpet.

Solution:

1. Determine the total surface area:

$$80' \times 20' \times 2' \text{ (walls)} = 3200$$

$$40' \times 20' \times 2' \text{ (walls)} = 1600$$

$$80' \times 40' \times 1' \text{ (ceiling)} = 3200$$

$$80' \times 40' \times 1' \text{ (floor)} = 3200$$

$$\text{Total Area} = 11200 \text{ sq. ft.}$$

2. Connect (area=11200) and (medium hard) on the nomogram. Extend the line to reference line and point the intersection.

3. Connect a line between the intersection point and (8 dB) on the reduction line.

4. The number of baffles required is 200.

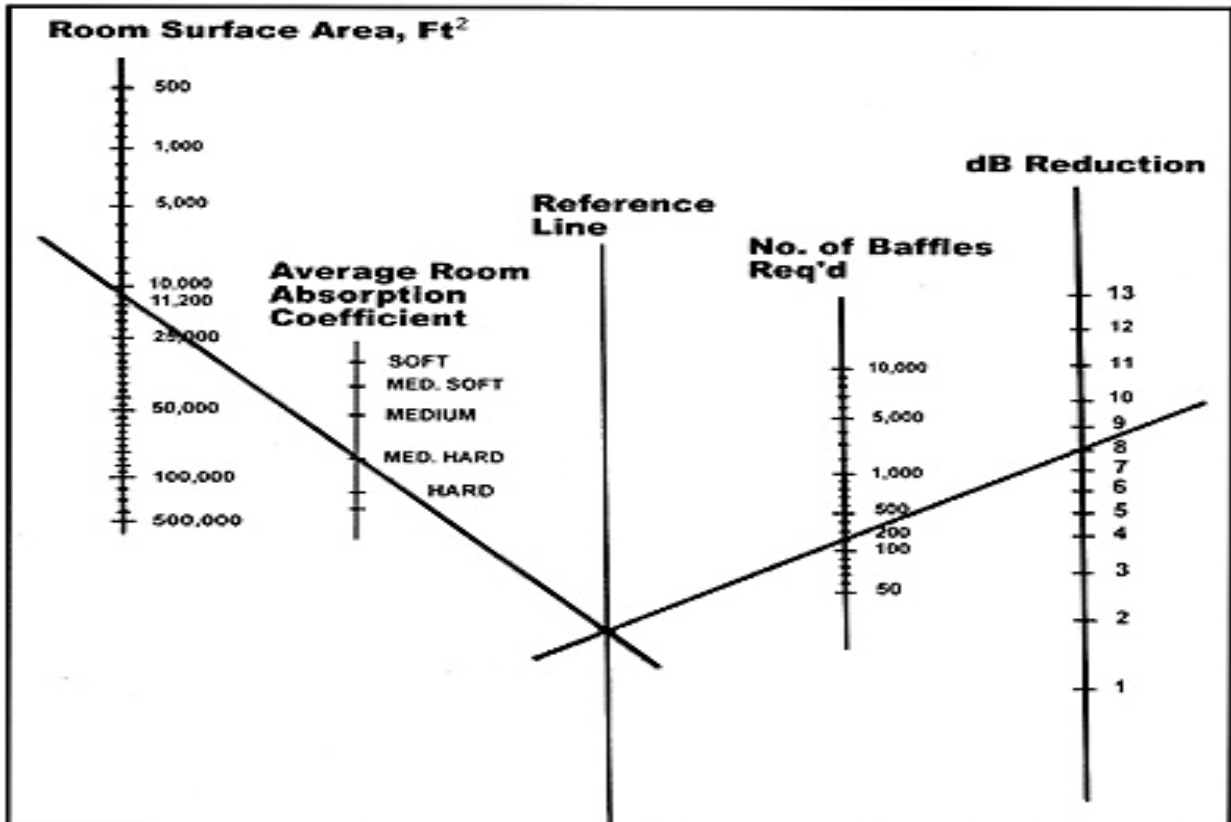

Chapter Four

Waterproofing Insulation

Chapter Four

Waterproofing Insulation

4.1 Waterproofing

All buildings need insulation from moisture, rain, groundwater and surface water because the dampness causes in damage of the construction materials and releases undesired smells with the breeding of insects and mice and bring diseases. The walls that exposed to the rain without sufficient amount of sunlight are more susceptible to dampness.

4.2 Effect of Dampness

- Damage of building materials and elements of the house.
- Efflorescence of the walls, floor and ceiling.
- Damaging the paint.
- The failure in the timber used and wooden décor.
- Corrosion of metallic parts.
- Proliferation of fungi and unhealthy situation for users in the building.

4.3 Causes of Dampness

1. Rain water: The rain water has the ability to penetrate the roof of the building, especially for poor surfaces and absence of gutters. Rain could penetrate the windows in absence of overhangs.

2. Surface water: This means river, sea or pond. The water mixes with the soil close to the building and forming a clay then moisture seeps to the foundations or inside through the capillary action.

3. Underground water: The accumulated water under the earth's surface could be transmitted through the pores of the soil by the capillary action and ascend to the foundations or inside hence damage the structural materials used in the building. It could even overflowing into the building.

4. Condensation: It is noticed in winter days a layer of dew formed on the window or even wall, and this phenomenon is called "condensation". The accumulated moisture on windows, walls, ceiling and floor seeps into the parts of the house after a period of time and leads to the fragility of construction materials and the appearance of rust, mildew and odors.

5. Poor sewage drainage: When wastewater gathers under the building and it was hard to flow downstream because of some restrictions then dampness could be occurred in the nearby elements of the building.

6. Modern construction: The walls newly constructed remain in the wet state for a certain period.

Capillary action: It is the ability of water to transport through the small pores of the material with the help of the forces of adhesion and cohesion. The capillary action occurs in porous materials like sponge, brick, concrete and many construction materials.

4.4 Types of Waterproofing Insulators

The purpose of waterproofing materials is to prevent the water as well as the moisture and keep it away from building elements. In order to choose the appropriate isolator of humidity it must take into account the nature of the ground (concrete, stone, clay, metal) as well as the climate (dry, wet). The method is characterized by the development of the insulation layer or membrane resists water pressure and using materials to prevent leakage of water or moisture into building elements.

The main types of waterproofing materials are:

- **Bitumen:** It is a black material made from the rest of the distillation of crude oil. Bitumen is very common in waterproofing isolation because of its cheapness compared to the other insulating materials in addition to its flexibility and resistance to the proliferation of fungi and insects. Bitumen is available in drums where it should be heated to about 80 degrees to melt. The most famous types are:

- Liquid of bitumen which is used to fill the cracks in the concrete or roof tiles. Sometime, adhesive is added to the resin components and it is called "mastic". Bitumen could be used as paint (1-2 mm) for the foundations and walls that are in a direct contact with the soil.

- Solid of bitumen (asphalt) which is used for paving of the street after mixing with sand and stones.

- Flancoat: a waterproofing material of bitumen used for coating surfaces of concrete in contact with the soil to prevent the dampness. It is effective and easy to use and does not need any mixing with any compound. It does not need to melt, where a brush or a roll is used to paint the surfaces. Often, it is available in black, but there are many other colors.

- Bitumen rolls: These layers have the excellent isolating and waterproofing capability. They are made of bitumen and sometimes covered by a reflective metallic sheet to reflect the heat. The bitumen layer commonly used to insulate the ceiling or walls and it is available in (3, 4 and 5 mm) thickness.

- **Acrylic:** It is a water resistant material and frequently used for waterproofing of the building roof and the floor of swimming pool. This material is composed of polyester fibers submerged in a liquid resin of polyacrylonitrile, where the required surface should be painted (many layers) and exposed to air to dry quickly and becomes a flexible insulating layer. This substance has a high susceptibility adhesion to various building materials. It is long-life and environment-friendly material.

- **Waterproofing liquid:** This liquid is made from the mixing of paraffin's wax with volatile oil. The waterproofing liquid is used to spray or paint the required surfaces.

- **Epoxy:** A polymeric material sticky and has rapid solidification used to process the holes and cracks.

- **Cement:** In case of free of impurities, cement could be a good resistant insulator. Cement is available as:
 - Portland cement: the increasing of the amount of cement in cement-sand mixture increases the resistance.
 - White cement: it is used to fill the separations in marble tiles for bathrooms and balconies.

- **Fiberglass:** It is a hard kind that results from mixing the glasswool with the epoxy. It is characterized by high resistance to the water therefore used in tank construction. Glasswool could be also mixed for the purposes of strengthening bitumen waterproofing layer.

- **Sheets or layers:** Surfaces could be isolated using many layers like:
 - Polyethylene membrane: Polyethylene is a flexible material that resists moisture and is often found in a very thin layer.
 - Rubber sheets
 - Extruded polystyrene (XPS) layers.
 - Layers of Mass Loaded Vinyl (MLV).
 - Nylon: It can be used between different parts of the building or between the layers of insulators, as well as to cover the foundations.
 - Metallic sheets: slabs, roofs and walls could be covered by a tiny layer of metallic sheet such as copper and aluminum plates. These metals are commonly used to make water storages.

- **Shingle:** These tiles have good isolation and used to cover the inclined surfaces and remove the accumulated water. A shingle is made of durable material like brick, stone or composite material and has a beautiful appearance.

- **Asbestos:** It is ceiling panels characterized by light weight and resistance to water, heat, fire, acids and fungi. The asbestos panel is often used in roofing but it is prohibited recently due to its harmful effect to the body health and environment.

- **Rocks:** Such as marble and granite. They are characterized by hard surfaces so a high resistance to the water. Marble is commonly used as floor tiles in kitchens and bathrooms. These rocks could be used to make the statues.



Asphalt



Bitumen paint



Shingles



Bitumen rolls



Acrylic



Polyethylene membrane

Fig. (4.1) Waterproofing materials

4.5 Practical Waterproofing Treatments

A. Waterproofing of foundation

1. Paint foundation surface using bitumen paints to prevent water transport and to provide adhesion between the concrete and insulation layer.
2. Paste a layer of tarpaulin to protect the foundation from direct contact with water.
3. Put a layer of thermal insulator.
4. Fill the neighboring land to the foundation by stones to resist the permeability of the water as much as possible (see the figure below).

B. Waterproofing of walls

1. Paint wall surface using bitumen paints to prevent water transport and to provide adhesion between the wall and insulation layer.
2. Paste a layer of tarpaulin, to protect the walls from direct contact with water, starting from the underground to prevent dampness path to the top.
3. Put a layer of thermal insulator.
4. Finishing works by a layer of mortar or marble.

C. Waterproofing of roof

1. After the casting of concrete, surface should be cleaned and the cracks should be treated carefully using grout or epoxy.
2. Provide appropriate inclination towards the gutters and treating the cumulative area by a layer of cement.
3. Paint concrete surfaces using bitumen paints to provide adhesion between the concrete and the insulation layer.
4. Put a layer of waterproofing material.
5. Put a layer of thermal insulating material.
6. Put a layer of soil and then covering with impervious tiles or insulating membrane such as acrylic.



Fig. (4.2) Waterproofing of foundation

4.6 Engineering Calculation in Water Transport

Permeability: It is a measure of the ability of a porous material to allow liquids to pass through it; hence it is the inversion of the resistance. The unit of permeability is Darcy (D).

$$1 \text{ Darcy} \approx 10^{-12} \text{ m}^2$$

Velocity of the liquid in a permeable material is given by:

$$v = \frac{\kappa \Delta P}{\mu \Delta x}$$

Where:

v = flow velocity through the medium (m/s)

k = coefficient of permeability of the medium (m^2)

μ = dynamic viscosity of the fluid (Pa·s)

ΔP = Applied pressure difference (Pa)

Δx = thickness of the bed of the porous medium (m)

The table below shows values of water permeability for some materials.

Table (4.1) Values of water permeability for some materials

Unconsolidated Sand & Gravel	Well Sorted Gravel	Well Sorted Sand or Sand & Gravel			Very Fine Sand, Silt, Loess, Loam									
Unconsolidated Clay & Organic					Peat		Layered Clay			Unweathered Clay				
Consolidated Rocks	Highly Fractured Rocks				Oil Reservoir Rocks			Fresh Sandstone		Fresh Limestone, Concrete		Fresh Granite		
κ (miliDarcy)	10 ⁸	10 ⁷	10 ⁶	10 ⁵	10000	1000	100	10	1	0.1	0.01	0.001	0.0001	
Strength	Pervious				Semi-Pervious				Impervious					

Example: A swimming pool of 60 m² has a concrete floor of 10 cm thickness and exposed to 20 kPa pressure difference of water. Determine the discharge of water across the concrete. (μ of water = 0.001 Pa.s) (k of concrete = 0.01 miliDarcy). What will be the difference if granite is used (k of granite = 0.001 miliDarcy).

Solution

- In case of concrete

$$v = \frac{\kappa \Delta P}{\mu \Delta x} = (0.01 \times 10^{-3} \times 10^{-12} / 0.001) (20000 / 0.1) = 0.2 \times 10^{-8} \text{ m/s}$$

$$Q = v \times A = 0.2 \times 10^{-8} \times 60 = 12 \times 10^{-8} \text{ m}^3/\text{s}$$

- In case of granite

$$v = (0.001 \times 10^{-3} \times 10^{-12} / 0.001) (20000 / 0.1) = 0.02 \times 10^{-8} \text{ m/s}$$

$$Q = v \times A = 0.02 \times 10^{-8} \times 60 = 1.2 \times 10^{-8} \text{ m}^3/\text{s}$$

Sorption: It is the tendency of water to rise into porous materials by capillary action. Thus, no water pressure is required. The quantity of water absorbed into the material by capillary action is given by:

$$V = A S \sqrt{t}$$

Where

V = accumulated volume by absorption (m³)

A = wetted area (m²)

S = Sorptivity of the material (m/√min)

t= time (min)

Table (4.2) Values of water sorptivity for some materials

Material	S (mm/√min)
Stone	0.15
Concrete	0.2
Block	0.5
Brick	1.1
Cement	1.5
Gypsum	3.5
Soil	40

Example: Brick wall (S=1.1 mm/√min) of 5 m width, 3 m high and 25 cm thickness is attached to underground water. What would be the dampness level for a period of one month, if the water touches 10 cm of the foundation height.

What is the difference if impervious brick (S=0.1 mm/√min) has been used.

Solution:

$$V = A S \sqrt{t} = (5 \times 0.1) \times 1.1 \times 10^{-3} \times \sqrt{30 \times 24 \times 60} = 0.114 \text{ m}^3$$

$$\text{Water rise} = V / A = 0.114 / (5 \times 0.25) = 0.091 \text{ m}$$

It means that the water will rise approximately 9 cm after a month.

For the case of impervious brick it is less than 1 cm monthly. Check it!!

Chapter Five

Radiation Insulation

Chapter Five

Radiation Insulation

5.1 Introduction

It is known that various electromagnetic waves and particles emitted from radioactive sources have direct and indirect effects on living organisms, where many symptoms could be happened when expose to radiation more than allowed. Workers in nuclear facilities and X-ray labs exposed to the risk of external, which affects the face, hands or internal exposure due to the entry of radioactive particles into the body through breathing and food. To avoid the radiation risk in this area it is necessary to know the nature of radiation and methods of isolating and comply with the instructions for the prevention of it as mentioned in this chapter.

5.2 Radiation

Radiation is energy released in the form of electromagnetic waves has many forms, such as light, ultraviolet and infrared or small particles from radioactive materials like alpha, beta and gamma. The source of this radiation is universe, sun, nuclear reactors, industrial and laboratory applications. Some substances found in the earth are also characterized by radiation. There is a little radioactivity within the body. Electromagnetic waves consist of photons; shortest waves are gamma rays while the longest are radio waves.

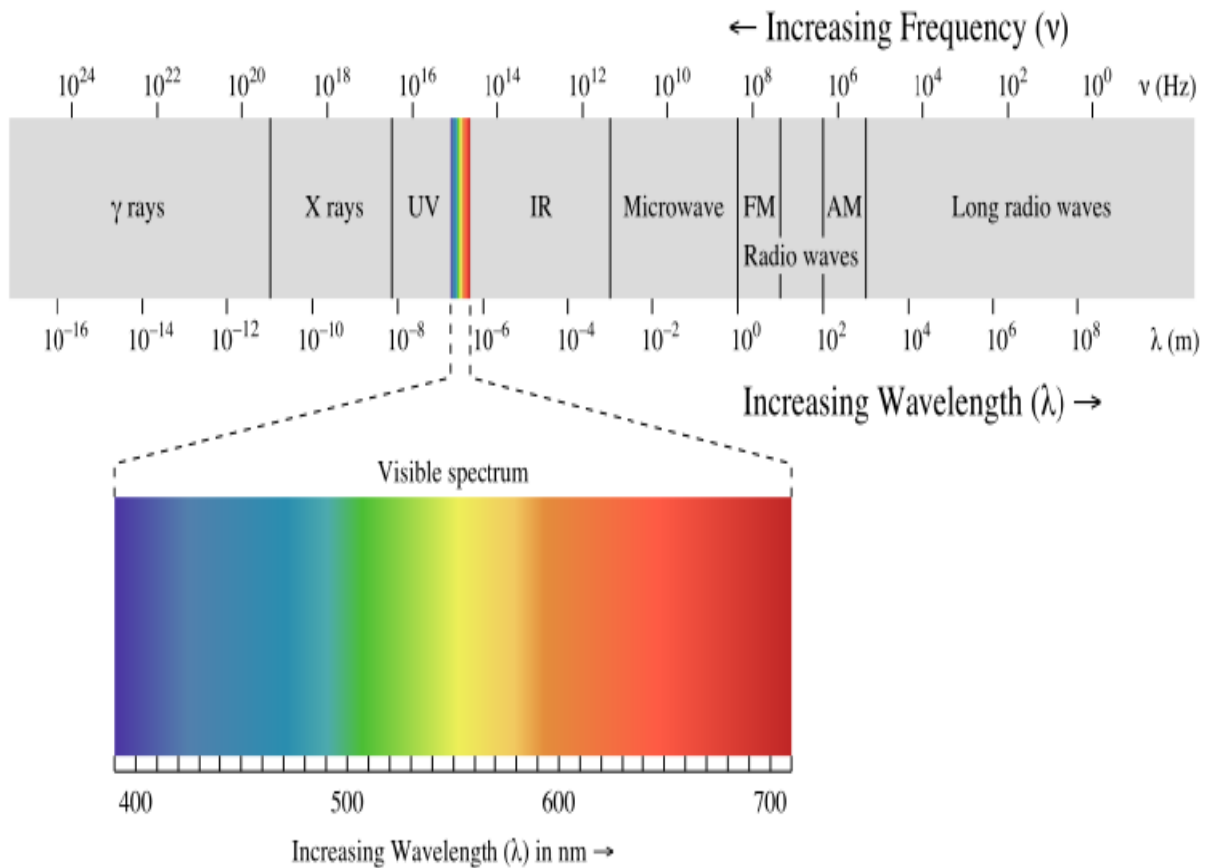

Fig. (5.1) Electromagnetic waves

5.3 Classification of Radiation

Radiation could be classified according to its danger as following:

- 1. Non-Ionizing Radiation:** Examples of this radiation light, infrared, ultraviolet and radio waves. This type of radiation is safe usually.
- 2. Ionizing Radiation:** Such as cosmic rays, gamma rays, alpha particles and beta particles. It is dangerous because of its ability of ionizing.

5.4 Non-Ionizing Radiation

The sources of these rays are sun or industrial applications. These rays are not inherently dangerous, but when prolonged exposure to it has caused cases of discomfort or headaches queasiness or dryness of hair and sometimes minor skin burns. Clothes, sunglasses and shading protect us from these rays.

5.5 Types of Non-Ionizing Radiation

1. **Light (the visible spectrum):** It is a very useful radiation. It provides the light and control many biological functions such as: strengthen of bone tissue, maintain the blood pressure, diabetes level, cholesterol level and psychological comfortable. It has a big role in the growth of plants by photosynthesis.

2. **Infrared:** It is very useful where provides the warmth and used for many applications like: night vision, short-range wireless communications and remote sensing.

3. **Ultraviolet:** It is a useful radiation except one band of it. These rays help to provide the body with vitamin (D). There are many application of UV like: water and medical sterilization, reducing the yellowing with newborns. The long exposure to UV harms the skin and the eye. It is worth to refer that that these rays are the cause of damaging plastics and insulating polymeric materials because of their ability to destroy the chemical bonds.

4. **Radio waves:** Such as the broadcasting of radio, television, telecommunications and microwave wavelengths. Despite the benefits of these rays in the transfer of information, they have some harmful effects on humans, especially on the nervous side and the senses.

5.6 Ionizing Radiation

It includes rays or particles come from the sun, the universe or radioactive elements (such as radium, uranium, plutonium, thorium, iodine, potassium, zircon, phosphor and radon). The radiation that is emitted from these sources could ionize the medium, which means detaching the electrons from atoms.

5.7 Radioactivity

Most of the chemical elements have the same number of neutrons and protons in the nucleus. in some elements the number of neutrons is greater than the number of protons, so that be unstable and called radioactive isotopes. these isotopes emit small particles from the nuclei such as alpha particles, beta particles and gamma rays. Over time, these elements are transformed into other elements less weight and have various chemical and physical characteristics. The emitted particles and rays are considered as ionizing radiation. The characteristics of radioactive isotopes depend on the type of radiation emitted, energy of radiation and its half-life.

Half-Life: It is the time needed to disintegrate half of atoms of a radioactive element, hence reducing the activity by half. For example, the half-life of (iodine -131) is 8 days while the half-life of (radium -226) is 1600 years.

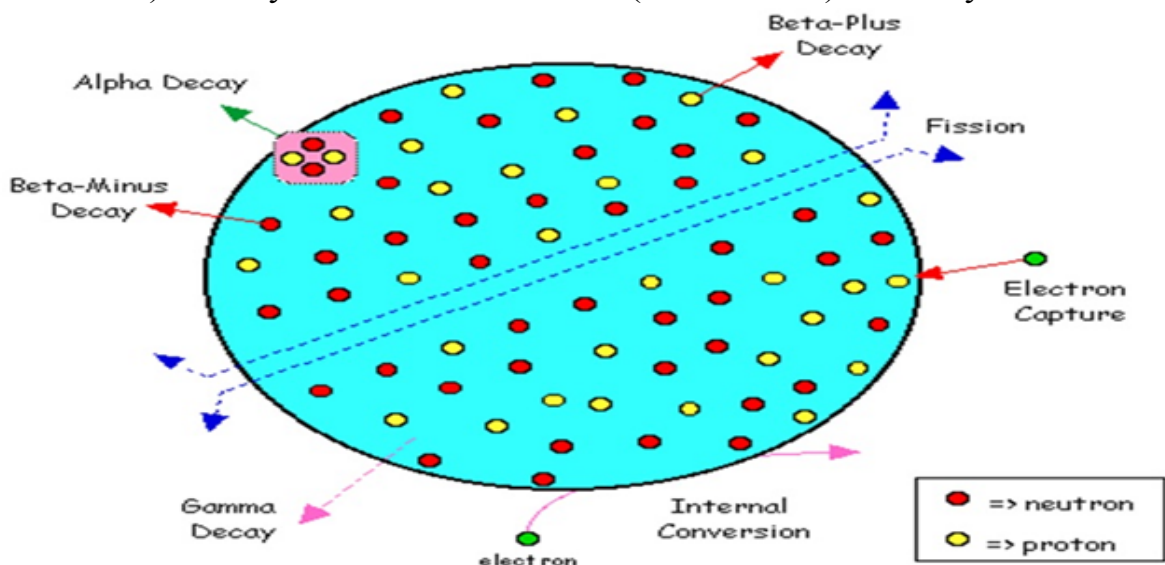

Fig. (5.2) The disintegration of the radioactive isotope

5.8 Types of Ionizing Radiation

1. Alpha particles: alpha particle is emitted from the nucleus during the decay. It consists of two protons and two neutrons (i.e. similar to the nucleus of the helium atom) so alpha has positive electrical charge. These particles lose energy quickly as soon as leaving the radioactive element. Hence, the penetration of alpha particles to the skin is weak, and it could be blocked by a thick paper. The risk of alpha particles appeared when enter to the internal parts of the body by breathing, eating or wounding.

2. Beta particles: These particles are emitted from the nucleus during the decay. It is noticing, during the breakdown of neutrons, that beta particles may be produced either as electrons (negative charge) or as positrons (positive charge), or in sometimes whole neutrons are emitted to the outside. Beta has more penetration force than alpha, and some beta particles can penetrate the skin and damage it. It also causes harmful effects if entered to the body. Beta radiation could be blocked by a piece of wood or a layer of aluminum (10-20 mm).

3. Gamma rays: This type of radiation represents the energy generated by the disintegration that is occurred within the nucleus. The emission of alpha and beta particles pushes the nucleus to the stability phase, hence emits energy (photons) out in the form of gamma rays. There is a kind of gamma rays called annihilation radiation which is produced from the combination of electrons and positrons. this radiation is one of the most dangerous types of radiation and has very high penetrating force, where it can easily penetrates the human body and absorbed by the tissues. It could be blocked by a barrier of concrete or a layer of lead (4-12 mm).

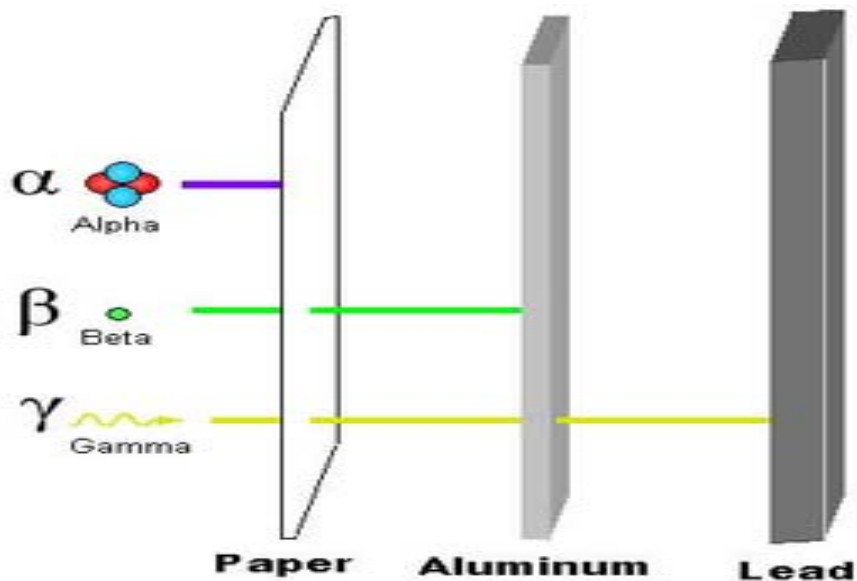

Fig. (5.3) Shielding for some types of radiation

4. X-rays: These rays are similar to gamma rays in terms of features but differ in the source, where X-rays are emitted from the outside of nucleus (transportation of electrons between the energy levels), while gamma rays are emitted from the inside of nucleus. Penetration force and permeability of these rays are less than that of gamma rays, where it could be blocked by a thin layer of lead (1-3 mm).

5. Cosmic rays: These are high-energy particles coming from the space. Mostly, this radiation is dissipated through the upper layers of the atmosphere, but a few percent in. This dangerous radiation could be blocked by a layer of composite materials or chemical compounds.

5.9 Risks of Ionizing Radiation

The ionizing radiation could ionize the medium, which means detaching the electrons from atoms. The Ionizing of the constituent elements of the biological material of the recipient's body causes the increase or decrease in the size of the cell or fragmentation, hence the formation of toxic compounds that may move to other parts of the body, leading to serious damage. These effects are appeared either early or later in the form of symptoms or disease like

cancerous diseases in addition to the hereditary effects of genetic influences. Workers in radiation facilities may get internal or external exposure. Internal exposure to ionizing radiation occurs when inhaling or swallowing radionuclides or entry into the bloodstream. External exposure occurs when radioactive materials attached to the skin. The type of damage is inflicted by the amount of radiation dose to the body according to the level of exposing. Usually the risks of radiation are: skin redness, burns, hair loss, syndrome of radiation, bleeding, infertility and cancer in some cases.

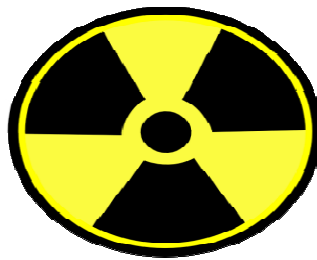

Fig. (5.4) Warning sign for ionizing radiation

5.10 Radiation Measuring

Radiation intensity is measured in a unit called Sievert, denoted as (Sv) and consists of 100 Rem. Human may expose to a dose of radiation that is measured using an instrument called radiation meter, as shown in the figure, which often works within the limits (0.1 - 200 μ Sv/h).



Fig. (5.5) Radiation meter

5.11 Means to Minimize the Risk of Radiation

Person who is working in the field of radiation may expose to a dose of radiation depending on the nature of the work. The commitment to the following aspects is very important to reduce the risk of radiation.

1) Time of Exposing

Radiation is less dangerous in the case of reducing the exposure time (time spent by the person beside the radiation source). The maximum exposure limit allowed to the human is (0.05 Sv/yr) according to the recommendations of international councils such as (ICRP) and (USNRC). In order to calculate the amount that is permitted to those working in the field of radiation, the exposure limit is divided by the total working time. Hence, for 8 hours and 360 days, the allowed limit is 17 μ Sv/h.

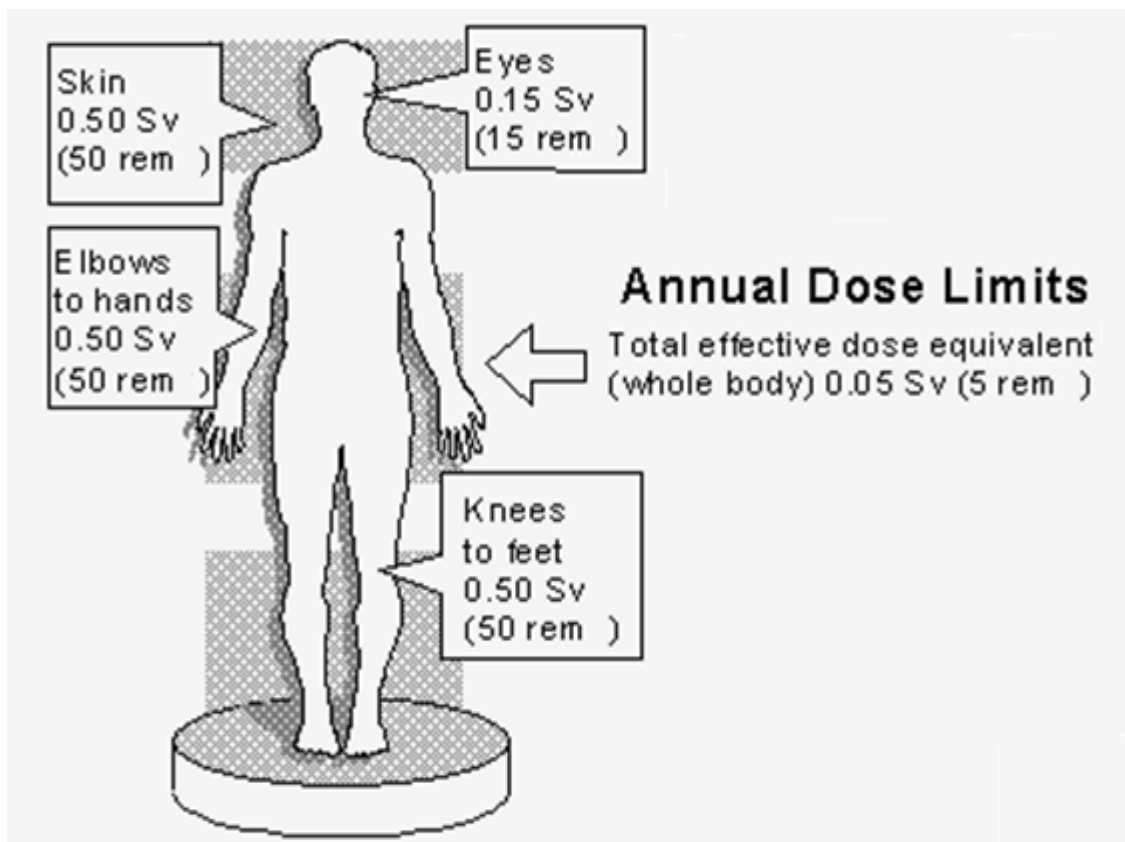

Fig. (5.6) Exposure limits

2) Exposure Distance

The increasing of distance far from the radiation source will reduce the intensity of the radiation (inverse relationship) according to the inverse-square law as following:

$$I_1 L_1^2 = I_2 L_2^2$$

Where:

I = Intensity of radiation

L= distance away from the source

3) Shielding

Radiation could be reduced using barriers consisting of metals or materials have the ability to either absorb the radiation and convert it to heat or reflect it. For each type of radiation there is appropriate barrier setting according to the intensity and the energy of radiation.

Linear Attenuation Coefficient: It represents the susceptibility of a material to reduce the radiation. It has the symbol (μ) and has the unit (cm^{-1}). The following table shows the value of the linear attenuation coefficient for some materials.

Table (5.1) Linear attenuation coefficient in (cm^{-1}) for a range of gamma-ray energies

Material	Energy (keV)		
	100	200	500
Carbon	0.335	0.274	0.196
Aluminum	0.435	0.324	0.227
Iron	2.72	1.09	0.655
Copper	3.8	1.309	0.73
Lead	59.7	10.15	1.64

More values for many different elements could be found in the link:

<http://physics.nist.gov/PhysRefData/XrayMassCoef/tab3.html>

It is noticed that, the value of linear attenuation coefficient decreases with the increasing of radiation energy (eV) passing through the material, as shown in the figure below.

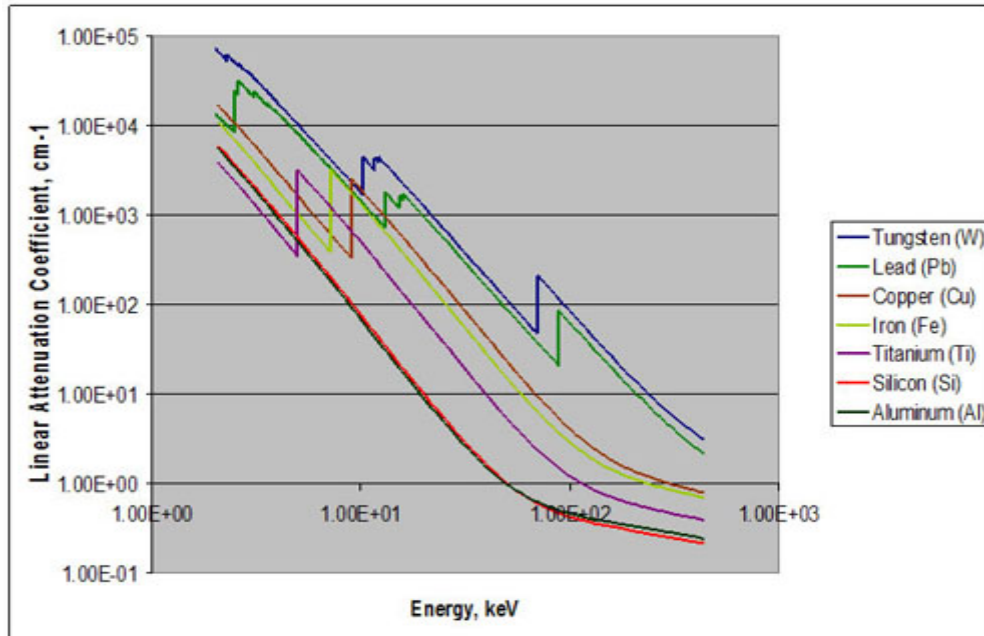

Fig. (5.7) The value of linear attenuation coefficient of some materials

Half Value Layer: It is the thickness of the material that satisfies half reduction of radiation (ie, attenuated by 50%). It is measured in centimeters and symbolized as (HVL). The following table shows some HVL for some elements.

Table (5.2) HVL in (cm) for a range of gamma-ray energies

Material	Energy (keV)		
	100	200	500
Carbon	2.07	2.53	3.54
Aluminum	1.59	2.14	3.05
Iron	0.26	0.64	1.06
Copper	0.18	0.53	0.95
Lead	0.012	0.068	0.42

5.12 Calculation of Radiation Attenuation

Beer-Lambert Law could be used to calculate the amount of attenuated radiation (gamma rays and rays) exit from the barrier, as following:

$$I = I_0 e^{-\mu x}$$

Where: I = the intensity of photons transmitted across some distance x
 I_0 = the initial intensity of photons
 μ = the linear attenuation coefficient
 x = distance traveled

Ex. (1): The intensity of 500 keV gamma-rays has measured at a zone and it was 25 $\mu\text{Sv/h}$. What would be the intensity after using a shield of 8 mm lead. ($\mu=1.64 \text{ cm}^{-1}$)

Solution:

$$I = I_0 e^{-\mu x} = 25 \exp(-1.64 \cdot 0.8) = 6.73 \mu\text{Sv/h}$$

Since the intensity is less than 17 $\mu\text{Sv/h}$ then sounds good.

Ex. (2): Three materials: aluminum (8 cm), iron (4 cm) and lead (0.4 cm) have exposed to 18 $\mu\text{Sv/h}$ at 200 keV. Determine the best shield.

Solution:

$$I = I_0 e^{-\mu x}$$

Material	$\mu \text{ (cm}^{-1}\text{)}$	Thickness (cm)	I ($\mu\text{Sv/h}$)
Aluminum	0.324	8	1.35
Iron	1.09	4	0.23
Lead	10.15	0.4	0.31

In this case, iron has the minimum attenuation, so it is the best shield.

Ex. (3): What thickness of copper is required to reduce the radiation intensity by 10%. Assume 200 keV.

Solution:

From HVL table for copper at 200 keV: HVL = 0.53 cm
 HVL means reduction by 50% so,

<u>%</u>	<u>X</u>
50	0.53
10	?

$$X = 10 * 0.53 / 50 = 0.106 \text{ cm}$$

Ex. (4): In the x-ray lab, a source of 60 keV radiates 1000 μSv (0.5 m beside the focal spot). What is the radiation intensity behind monitoring glass shielded by 1 mm tungsten ($\mu=58.5 \text{ cm}^{-1}$) at 2 m far from the source.

Solution:

$$I_1 L_1^2 = I_2 L_2^2$$

$$1000 (0.5)^2 = I_2 (2)^2 \qquad I_2 = 62.5 \text{ } \mu\text{Sv radiation at 2 m}$$

$$I = I_0 e^{-\mu x} = 62.5 \exp(-58.5 * 0.1) = 0.18 \text{ } \mu\text{Sv radiation behind the shield}$$

Homework: Prove that the relationship between half value layer and linear attenuation coefficient is:

$$\text{HVL} = 0.693 / \mu$$

5.13 Applications of Radiation Insulation

1. Nuclear power plants

The main part of the nuclear plant is the reactor which contains the units of nuclear fuel (uranium, thorium, plutonium or iodine). Since there are series of nuclear fissions, hence the reactor is surrounded by a thick wall of steel (25 cm) to retain high vapor pressure and to prevent radiation leakage (particles) to the outside. It should also cover the surfaces in direct contact with the nuclear explosions by a layer made of highly absorbent material to neutrons, such as cadmium alloy. The energy emitted (photon) is absorbed by the water which encloses the reactor. This energy leads to boil the water which is taken to the turbine to generate electricity.

2. Radioactive waste

It means the remnants of nuclear plants or it is related to chemical anti-armor weapons. The problem of radioactive waste emerged several decades ago, it was found that these materials remain effective and radiate particles that could be absorbed by nearby plants and insects and then transmit to humans and infect the internal parts. However, there are several ways to keep the danger of these substances, including:

- a. Storing in plastic barrels into the ground and in the desert areas.
- b. Storing in concrete tanks surrounded by salt or gypsum.

3. X-ray lab

In hospitals, it should pay some attention to the X-ray lab. It should offer a private room for X-ray capturing without any internal windows. Wall should be built from brick or concrete, but if there is an internal separator, door or control window, then it should be isolated by a layer of lead (2 mm). X-ray tube should be placed at least half meter far from the body.

4. Airplanes

Recently, the external parts of the aircraft are replaced by composite materials in order to reduce weight and cost. This procedure increases the risk of radiation because the attenuation coefficient of polymeric material is very weak. To process this problem, a deposition of a thin layer of lead is required, or intercalation small grains of absorbent materials (such as bromine) within the composite material.

5. Spacecrafts

Spacecraft is exposed to high-energy gamma rays, cosmic rays and particles. So, it should use accurate shielding materials. External shells are covered by alloys of high z-materials such as: lead, tungsten, gold, vanadium and titanium. For the inner layers, usually use materials with high hydrogen such as lithium-hydride. In addition to the prevention of radiation, shields must enclose some magnetic parts made of ferromagnetic materials such as (iron, nickel and cobalt). The providing of magnetic field protects the craft against solar hurricanes and cosmic rays.

5.14 Advanced Techniques in Shielding

The use of composite materials technology in radiation barriers is common because of the economic and qualitative benefits. The following table shows some composite materials used in radiation shields and their applications.

Table (5.3) Composite materials used in radiation shielding

Material	Description of composite	Density (g/cm ³)	Application
Pb6	Anhydride (polymer+Pb+W+Ti)	5.6	Nuclear
Jxa	Polyamide (polyamer+Pb+W+Gd)	3.4	Nuclear
GFRP	Glass fibers	2	Airplane
P100+Br	Graphite-epoxy intercalated by bromine	1.7	Airplane
Kevlar or Vectra	hydrogenous using liquid-crystal polymer (LCO)	1.6	Airplane, spacecraft
Nomex or Aramid	Aramid polymers	1.5	Airplane, spacecraft
Interlayer	Polyamide without any dense absorber elements	1.4	Radioactive waste
Dibutyl Sebacate	Organic ester	0.9	X-ray lab

Chapter Six

Electrical Insulation

Chapter Six

Electrical Insulation

6.1 Introduction

Insulators are used in many applications; to wrap electrical cables or in electrical equipment to separate electrical conductors. The term insulator is also used more specifically to refer to supports that used to attach electric power transmission lines to towers and poles. They support the weight of the suspended wires without allowing the current to flow through the tower to ground. An electrical insulator is a material whose internal electric charges do not flow freely, and therefore make it nearly impossible to conduct an electric current under the influence of an electric field. This contrasts with other materials which conduct electric current more easily. A perfect insulator does not exist, because even insulators contain small numbers of mobile charges (charge carriers) which can carry current.



Fig. (6.1) Applications of electrical insulators

6.2 Classification of Materials

It is known that any substance contains a number of molecules and atoms. These atoms have some electrons in the outer orbit called "free electrons". Due to the ease expelled of the free electrons from the external orbit and make it move easily to another atom, and so on creating a flow of electrons called "electrical current".

Materials are classified according to its ability to conduct electricity to:

1. Conductors

A conductor is an object or type of material that allows the flow of electrical current in one or more directions. The mobile charged particles are usually the electrons. Conduction materials include metals (copper, aluminum, iron, etc), electrolytes, superconductors, semiconductors, plasmas and some nonmetallic conductors such as graphite and conductive polymers.

Copper has a high conductivity and it used for many applications, such as building wire, motor windings, cables and busbars. Because of its ease of connection by soldering or clamping, copper is still the most common choice for most light-gauge wires. Aluminum has higher conductivity than copper, but it has some problems. Where, it can form a resistive oxide that makes wires unable to terminate heat. Aluminum can creep, slowly deforming under load, eventually causing device connections to loosen, and also has a different coefficient of thermal expansion. This accelerates the loosening of connections. However, aluminum wires could be used for low voltage distribution, such as buried cables and service drops, require use of compatible connectors and installation methods to prevent heating at joints. Aluminum is also the most common metal used in high-voltage transmission lines, in combination with steel as structural reinforcement. Silver is more conductive than copper, but due to cost it is not practical. However, it is used in specialized equipment, such as satellites, and as a thin plating to mitigate skin effect losses at high frequencies.

2. Semiconductors

Semiconductors are crystalline materials or amorphous solids with higher resistance than typical conductors but still much lower than insulators. Their resistance decreases as their temperature increases, which is behavior opposite to that of a metal. So, their conducting properties may be adopted in useful ways (for some purposes like in diodes and transistors) by doping of impurities into the crystal structure to reduce its resistance. Doping is important to increase the number of charge carriers within the crystal. When a doped semiconductor contains mostly free holes, then it is called "p-type", and when it contains mostly free electrons, then it is known as "n-type". Many pure elements and some compounds display semiconductor properties like silicon, germanium, compounds of gallium, and mixtures of (arsenic, selenium and tellurium).

It is important here referring to the term "energy gap" which is the energy required by an electron to move from valence band to conduction band. This is equivalent to the energy required to free an outer shell electron from its orbit to become a mobile charge carrier, able to move freely within the solid material. The energy gap is a major factor determining the electrical conductivity of a solid. Substances with large band gaps are generally insulators, those with smaller band gaps are semiconductors, while conductors either have very small band gaps or none, because the valence and conduction bands overlap.

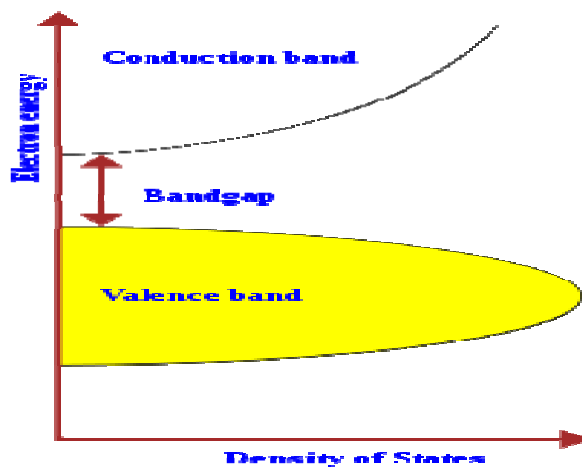

Fig. (6.2) Semiconductor energy structure

Table (6.1) Energy gap for common semiconductors and insulators

Material	Symbol	Energy gap (eV) at 25 °C
plastics	-	6-10
Silicon dioxide	SiO ₂	9
Ceramics: Aluminum oxide (Al ₂ O ₃) Mullite (3Al ₂ O ₃ · 2SiO ₂) Forsterite (2MgO · SiO ₂) Beryllium oxide (BeO) Aluminum nitride (AlN)	-	4 - 8
Diamond	<u>C</u>	5.5
Silicon nitride	Si ₃ N ₄	5
Gallium nitride	GaN	3.4
Gallium phosphide	GaP	2.26
Copper oxide	Cu ₂ O	2.1
Gallium arsenide	GaAs	1.43
Silicon	Si	1.11
Germanium	Ge	0.67
Lead sulfide	PbS	0.37

3. Insulators

Those materials that do not allow the flow of electric current, such as: wood, plastic, quartz and ceramic. The main reason of the ability of these materials to restrict the electrical flow is that the atomic structure contains a very small number of free electrons midwife to move.

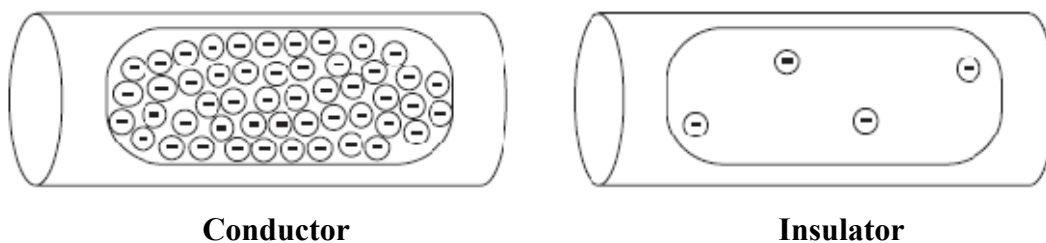

Fig. (6.3) Comparison between electrical conductor and insulator

It may understand the following from the figure:

- Material that contains a plenty of free electrons becomes a "conductor".
- Material that contains few of free electrons becomes an "insulator".

The electric field still active even in an insulating material, where an imbalance occurs and the positive charges attract to the electric field while the negative charges displace away. This separation between electrical charges generates the so-called "dipole" and the corresponding process called "polarization". The insulator that can be polarized by an applied electric field is called "dielectric material".

6.3 Types of Electrical Insulators

There are many types of insulators in electrical systems for various purposes and uses. Examples of electrical insulation materials are: plastics, rubber, wood, ceramics, glass, cellulose paper, and oils. Electrical insulators could be classified according to its application as following:

1. Plastic materials for wiring

Plastics are used to cover the electrical wires and to protect against electrical shock. Twisted pair cables usually insulated with polytetrafluoroethylene. Plastic materials that ideal for electrical insulation including: PVC, PP , PEEK , PTFE, PET, PES, PEI, ECTFE, PBT, FE

2. Electrical insulators for overhead transmission lines

The insulator should be able to withstand high working voltage, the over voltages due to lightning, and it should posses high mechanical strength to bear the conductor load under worst leading conditions. It also, needs to have a high resistance to temperature changes to reduce damage from power flashover. Porcelain, silicon and glass are commonly used for overhead lines discs. There are three main types of insulators used for overhead lines.

1. Pin type: this type is supported on a forged steel pin which is secured to the cross arm of the supporting structure.
2. Suspension type: A suspension insulator consists of a number of separate insulator disc units connected with each other by metal lines to form a flexible string or chain.

3. Strain (tension) type: Strain or tension insulators are design for handling mechanical stresses at angle positions where there is a change in the direction of the line or at termination of the lines.

3. Insulating oils

These oils are stable at high temperatures and have excellent electrical insulating properties. Oils are used in transformers, high-voltage capacitors and fluorescent lamp ballasts.

4. Powder coating

Powder coating technology is recognized as a superior method of applying a protective finish on numerous shapes and sizes, as opposed to wet applications. One approach that is effectively used as a high dielectric insulator on copper or aluminum conductors is epoxy powder coating. It is used to ensure consistent insulation barrier due to its durability. Epoxy powder coating negates concerns of cut-through or high-voltage spikes in cable insulations. The surface requires cleaning and drying prior to the powder application.



Fig. (6.4) Powder coating

5. Insulating varnishes

Varnish is used as sealant. Organic varnishes and solventless resins are widely used as insulators for electrical motors. They offer many advantages like:

- Improving the dielectric properties.
- Increasing the mechanical bonding to the winding wire.
- Protection to the winding against moisture and chemical corrosion

6. Capacitors

A capacitor (originally known as a condenser) is a passive two-terminal electrical component used to store electrical energy in the form of an electrostatic field. It consists of two electrical conductors (plates) separated by a dielectric (insulator) that can store energy by polarization. The conductors are metal foils or conductive electrolyte. A dielectric could be glass, ceramic, plastic film, air, vacuum, paper, mica, polymer or oxide layer.

6.4 Properties of Electrical Insulators

1. Resistance: is the ability of the material to repel the electrical current. The resistance of a given conductor depends on the material it is made of and on its dimensions. For a given material, the resistance is given by:

$$R = \rho \frac{L}{A}$$

ρ = the resistivity of the material (ohm.m)

L = length of the wire (m)

A = cross-sectional area of the wire (m²)

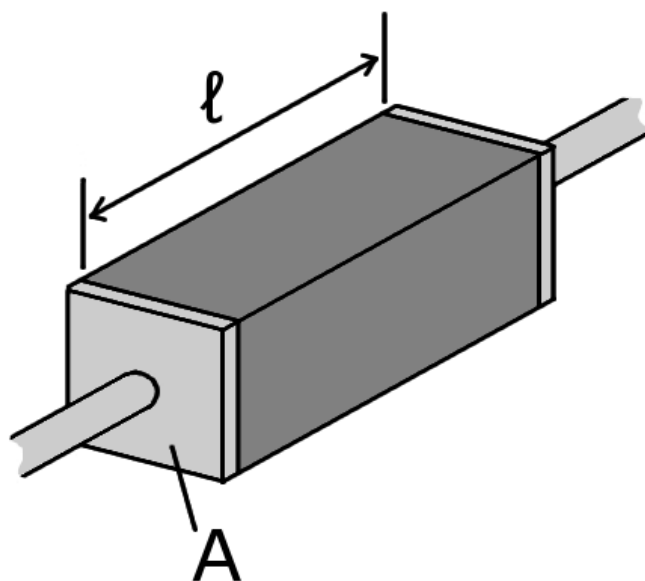

Fig. (6.5) A piece of resistive material

Resistivity is the property that distinguishes the insulators, where insulators have higher resistivity than semiconductors or conductors. Some materials such as glass, paper and Teflon, which have high resistivity, are very good electrical insulators. A much larger class of materials, even though they may have lower bulk resistivity, are still good enough to prevent significant current from flowing at normally used voltages, and thus are employed as insulation for electrical wiring and cables. Examples include rubber, polymers and most plastics.

Table (6.2) Resistivity for common materials

Material	ρ ($\Omega\cdot\text{m}$) at 25 °C	Material	ρ ($\Omega\cdot\text{m}$) at 25 °C
Carbon (graphene)	1.00×10^{-8}	GaAs	1.00×10^{-3} to 1.00×10^3
Silver	1.59×10^{-8}	Germanium	4.60×10^{-1}
Copper	1.68×10^{-8}	Water	2.00×10^{-1} to 2.00×10^3
Aluminum	2.82×10^{-8}	Silicon	6.40×10^2
Tungsten	5.60×10^{-8}	Wood (damp)	1.00×10^3 to 1.00×10^4
Zinc	5.90×10^{-8}	Glass	1.00×10^{11} to 1.00×10^{15}
Nickel	6.99×10^{-8}	Rubber	1.00×10^{13}
Iron	1.00×10^{-7}	Sulfur	1.00×10^{15}
Tin	1.09×10^{-7}	Air	1.30×10^{16} to 3.30×10^{16}
Lead	2.20×10^{-7}	Quartz	7.50×10^{17}
Titanium	4.20×10^{-7}	Polyethylene terephthalate (PET)	1.00×10^{21}
Mercury	9.80×10^{-7}	Teflon	1.00×10^{23} to 1.00×10^{25}
Carbon (amorphous)	5.00×10^{-4} to 8.00×10^{-4}	Ceramics	1.00×10^{12} to 1.00×10^{14}

2. Permittivity: is a measure of how an electric field affects a dielectric medium. In other words, the permittivity of a medium describes how much electric field is generated per unit charge in that medium. More electric flux exists in a medium with a low permittivity because of polarization effects. The best insulator is that which has a large permittivity. Since the increasing of the permittivity leads to increase the capacitance of the material, hence it could say that the permittivity increases the ability of the insulation to absorb more amounts of electrical charges and avoid the transfer of energy. Permittivity relates to the ability of material to resist an electric field. In SI units, permittivity (ϵ) is measured in farads per meter (F/m).

Permittivity is directly related to electric susceptibility, which is a measure of how easily a dielectric polarizes in response to an electric field, as following:

$$\epsilon = (1 + \chi) \epsilon_0$$

χ = electric susceptibility

ϵ_0 = vacuum permittivity (8.85×10^{-12} F/m)

H.W. Using the equation above; prove that for a vacuum $\chi = 0$

In engineering applications, permittivity is often expressed in relative, rather than in absolute terms. The relative permittivity of the material is also called the "dielectric constant", thus:

$$\epsilon_r = \epsilon / \epsilon_0$$

ϵ_r = relative permittivity of the material

Table (6.3) Relative permittivity (dielectric constant) for common materials

Material	ϵ_r
Vacuum	1.0
Air	1.0006
Conductive polymers	2-12
Wood	2-6
PTFE/Teflon	2.1
Polypropylene	2.2-2.36
Polyethylene	2.25
Polystyrene	2.4-2.7
Carbon disulfide	2.6
Polyimide	3.4
Paper	3.85
Silicon dioxide	3.9
FR-4	4.0
Concrete	4.5
Pyrex	4.7
Glass	3.7-10
Rubber	7
Diamond	5.5-10
Salt	3-15
Graphite	10-15
Silicon	11.7
Water (200 °C)	34.5
Water (20 °C)	80.1
Water (0 °C)	88
Calcium Copper Titanate (CCT)	1000 - 100000

3. Polarization: is the ability of insulating material to undergo the separation between electrical charges and its strength. All insulators become electrically conductive when a sufficiently large voltage is applied that the electric field extracts the electrons away from the atoms. This is known as "breakdown voltage" of an insulator. Hence, "dielectric strength" is the maximum electric field that an insulating material can withstand under ideal conditions without breaking down. Breakdown voltage gradient is usually expressed, as voltage drop per unit length (V/m), to measure the dielectric strength of the insulator.

Table (6.4) Dielectric strength for common materials

Material	Dielectric Strength (MV/m)
Air	3.0
Alumina	13.4
Glass	9.8 - 13.8
Silicone oil, mineral oil	10 - 15
Polystyrene	19.7
Polyethylene	19 - 160
Neoprene rubber	15.7 - 26.7
Distilled water	65 - 70
Fused silica	25-40
Waxed paper	40 - 60
PTFE ,Teflon	20 - 173
Mica	118
Diamond	2000
Vacuum	10

6.5 Engineering Calculations

1. Capacitors

Assume two parallel plates of area (A), separated by a small distance (d), are charged by positive (+Q) and negative (-Q) charges, as shown in figure. The Voltage between plates (V) is given by:

$$V = Q / C$$

Where:

Q = charges (coulomb)

C = capacitance between two plates

Voltage is also given by:

$$V = D d / \epsilon$$

Where:

D = field density (coulomb/m²) = Q / A

ϵ = absolute permittivity (F/m)

Thus; $C = \epsilon A / d$

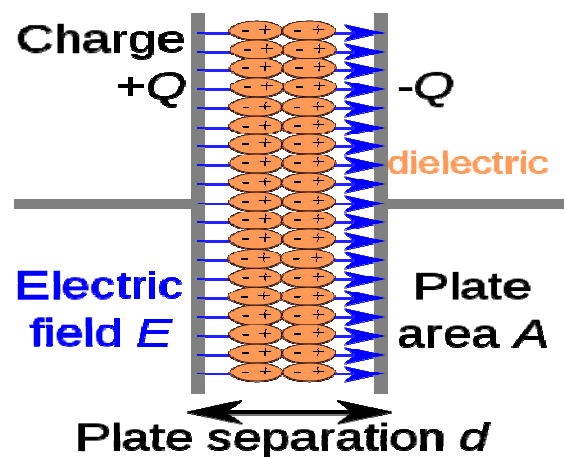

Fig. (6.6) Capacitor

Example: It is required to manufacture a capacitor of 17×10^{-9} coulomb/m² field density under 2.4 V between plates of 1 cm x 2 cm area and spaced 3 mm apart. Select the proper dielectric material used for this capacitor.

Solution:

$$V = D d / \epsilon \quad \text{or} \quad \epsilon = D d / V = 17 \times 10^{-9} \times 3 \times 10^{-3} / 2.4 = 21.25 \times 10^{-12} \text{ F/m}$$

$$\epsilon_r = \epsilon / \epsilon_0 = 21.25 \times 10^{-12} / 8.85 \times 10^{-12} = 2.4$$

From permittivity table we find that the material is polystyrene.

H.W.: It is required to manufacture a capacitor of 12×10^{-9} coulomb/m² field density under 3 V between plates of 1 cm x 2 cm area and spaced 2 mm apart. Select the proper dielectric material used for this capacitor.

2. Insulation discs

The major aspect in designing the discs for power transmission line is choosing its insulation level which has a considerable influence on the cost as well as operating reliability. The insulation disc is mainly related to the working voltage. A transmission line transmits electrical energy from generating station to distributing station. This voltage is usually about 11KV or 33KV. If the power is transmitted at these voltages for long distance, the power loss would be large. Therefore this voltage is stepped up to higher value by using step-up transformers. The various voltages adopted by different countries for long distance transmission lines are: 66 KV, 132 KV, 220 KV, 275 KV, 345 KV, 380 KV and 400 KV, as shown in table below. The number of insulator discs (string) should satisfies a balance between the chances of failure and the cost of greater insulation strength.

Table (6.5) Table for voltage selection

Distance (KM)	No. of Phases	Standard working voltage (KV)
Upto 8	3	6.6
Upto 16	3	11
Upto 64	3	33
Upto 116	3	66
Upto 240	3	132
Upto 480	3	220
Upto 800	3	400

Table (6.6) Selection of insulation discs

No. of units (Disc)	Power frequency withstand voltage	
	Dry KV(rms)	Wet KV(rms)
1	78	45
2	135	80
3	185	115
4	235	150
5	275	185
6	315	225
7	365	260
8	415	295
9	455	330
10	495	360
11	530	395
12	580	440
14	630	480
16	680	550

Example: Calculate the number of insulated discs required to overcome working voltage of 220 KV in a wet region. Use SF = 1.75.

Solution:

Safety voltage = $1.75 \times 220 = 385 \text{ KV}$

So, from the table, No. of discs = 11

