

LED

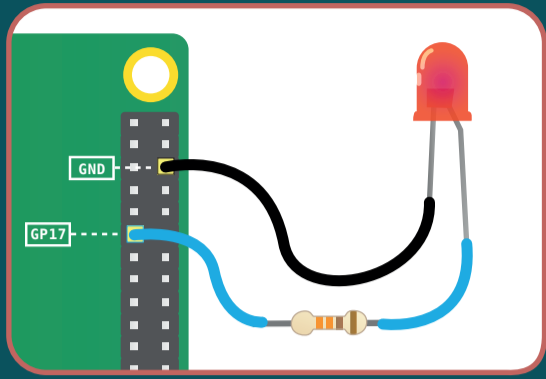

```
from gpiozero import LED
led = LED(17)
led.on()
```

led.on()

led.off()

led.toggle()

led.blink()

Full Colour LED

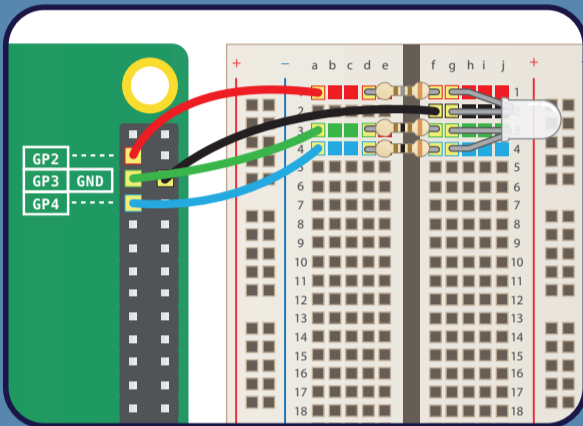

```
from gpiozero import RGBLED
led = RGBLED(red=2, green=3, blue=4)
r, g, b = 0, 0, 1
led.color = (r, g, b)
```

led.on()

led.off()

led.color = (r, g, b)

led.red = 1

Motor

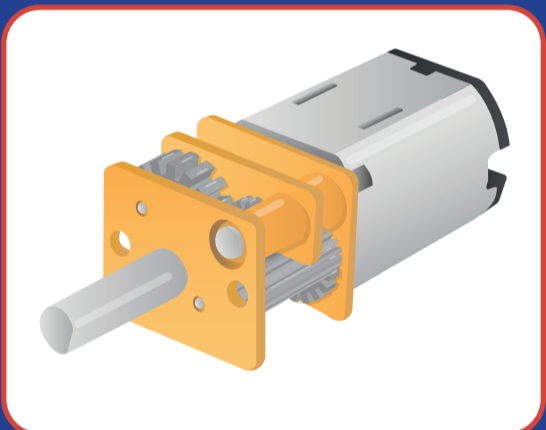

```
from gpiozero import Motor
motor = Motor(forward=17, backward=18)
motor.forward()
```

motor.forward()

motor.backward()

motor.stop()

motor.reverse()

Button

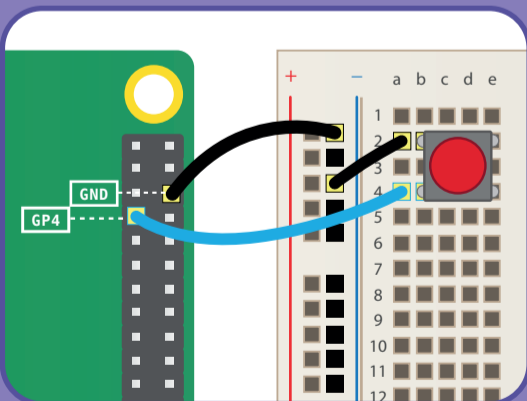

```
from gpiozero import Button
button = Button(4)
while True:
    if button.is_pressed:
        print("Button is pressed")
    else:
        print("Button is not pressed")
```

button.wait_for_press()

button.wait_for_release()

button.is_pressed

button.when_pressed = led.on

button.when_released = led.off

PIR Motion Sensor

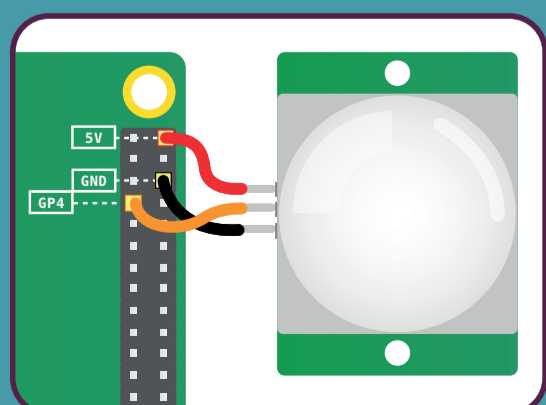

```
from gpiozero import MotionSensor
pir = MotionSensor(4)
while True:
    if pir.motion_detected:
        print("You moved")
```

pir.wait_for_motion()

pir.wait_for_no_motion()

pir.motion_detected

pir.when_motion = motor.forward

pir.when_no_motion = motor.backward