

--- Setback Line
 ■ Building Area

➔ ISSUE NUMBER FIVE

PRACTICE HYBRID CODING

Use	Distance from Property Line)	Code
Ground Floor	0'	A
Ground Floor	0'	B
Other Floor(s)	0'	C
Other Floor(s)	8'	D
Other Floor(s)	5'	D
Other Floor(s)	80% min.*	E
Other Floor(s)	30% min.*	F
Other Floor(s)	125' max.	G

Use	Height
Ground Floor	Service, Retail, or Recreation, Education & Public Assembly*
Other Floor(s)	Residential or Service*
Other Floor(s)	22'
Other Floor(s)	2.5 stories and 40'
Other Floor(s)	35'



ASK THE AUTHOR JOIN US ONLINE!

Go online from June 16 to 27 to participate in our “Ask the Author” forum, an interactive feature of Zoning Practice. Arista Strungys, AICP, will be available to answer questions about this article. Go to the APA website at www.planning.org and follow the links to the Ask the Author section. From there, just submit your questions about the article using the e-mail link. The author will reply, and Zoning Practice will post the answers cumulatively on the website for the benefit of all subscribers. This feature will be available for selected issues of Zoning Practice at announced times. After each online discussion is closed, the answers will be saved in an online archive available through the APA Zoning Practice web pages.

About the Author

Arista Strungys, AICP, is a senior associate at Camiros, Ltd. Her area of expertise is zoning and development regulations, and she has worked with communities across the country to create hybrid ordinances that combine traditional zoning regulations with form-based controls.

understood by staff, the community, property owners, developers, architects, and others involved in the development process. While there will be those controls that require a certain expertise, most provisions should be written so that they can be read and interpreted by the whole community. If residents do not understand the code, they will not trust it.

IMPLEMENTATION

Implementing new rules in built environments, where a substantial zoning tradition tied to existing bulk and use standards already exists, is also a challenge. In a sense, a “pure” form-based code can be easier to implement within a new or growing community because new development tends to occur upon a clean slate. A form-based code is easier to accept when it will be applied only in the future for new development.

However, within a built out community, many residents may feel that their existing code has served them well and do not understand why any revision is necessary. Often, a certain character develops out of tradition, not regulation, and residents do not realize that new development—under the existing rules—is not obligated to “match.” In many cases, existing zoning regulations permit new development by-right that is out of scale and character with existing development; new buildings that respect the existing character happen only by pure luck.

FIVE STEPS OF HYBRID CODING

The task of integrating design-oriented controls into a code may seem daunting, but there is a logical schedule of actions that determines which design elements should be incorporated, crafts the proper development controls, and builds public support for the new code. This can be broken down into five key steps. To help illustrate this five-step process, the Village of Riverside, Illinois, is provided as an example of how a hybrid code was drafted,

A “pure” form-based code can be easier to implement within a new or growing community because new development tends to occur upon a clean slate.

adopted, and implemented. Riverside is a National Historic District designed by Frederick Law Olmsted, so the built form is a key part of the community. Prior to adoption of the new regulations, an outdated zoning ordinance, which did not address the village’s historic character, controlled the form of development and potentially permitted projects that were out of scale and context. This example describes the hybrid coding process for both the central business district (CBD) and the residential districts, which were conducted as consecutive ordinance updates.

Step 1: Target the Area

The first step is to identify the area that will be subject to the regulations. In this step, the community must target the appropriate area and define its boundaries. While the target area does not require the district to have a singular character—different components of a district can be addressed through a subdistrict structure—it must have a unifying theme and purpose. Usually, it relates to a location, such as a central business district or commercial corridor, or a particular issue, like residential teardowns, that needs special “form-based” attention. In terms of code organization, the targeted area is often an

existing zoning district, but it can also require the creation of new districts or the application of zoning overlay districts.

After identifying the area, it is also important to consider the transitions. For example, if the anticipated form-based regulations are for the downtown, which is surrounded by single-family residential, it is important to address the transition from commercial to residential, especially if the downtown revisions encourage increased height or density. For example, regulations for a transition area may require town houses as a buffer between downtown development and surrounding single-family homes. This is where the subdistrict structure is useful.

Many times the issues throughout the targeted area are not the same. Using the same downtown example, a single set of architectural standards may be appropriate for the entire area, but the use structure may not be. A downtown core would desire more lively uses like retail stores, coffee shops, and restaurants, while office uses along the ground floor would not be appropriate. However, ground-floor offices could be ideal for other commercial streets within the district. The subdistrict structure can take them into account much like the town house transition area. This organizational technique allows a community to tailor the uses for each of these subareas to achieve specific goals, while maintaining the same design character throughout.

In Riverside, zoning for the CBD required definition of the area, while the residential districts dealt with the issue of out-of-scale new development. This provides a good illustration of how hybrid coding can be either place or issue specific. In the case of the CBD, all of the village’s business uses were grouped under one zoning classification, which did not distinguish between the historic CBD and the commercial corridor uses

along a major arterial at the eastern boundary of the village. Therefore, Riverside had to create a new district. However, while the boundaries of the historic CBD were relatively straightforward, one set of use controls was insufficient to define the use of different areas within the core. Therefore, the hybrid code divided the CBD into three subdistricts: the retail core, which was the heart of the district; the public use zone for village and public open space uses; and the mixed use periphery, which helped to address transitions from the retail core. Because the common thread throughout all three subdistricts was building design, most of the design standards applied throughout the new district.

In the residential districts, the village was concerned about the scale of new development. Because the majority of Riverside is

Basic zoning regulations will establish density, permitted uses, and lot sizes, but design controls will direct the physical character of new construction. Built out communities often use hybrid coding to preserve or restore historic character and, at the same time, address modern development needs, such as flexibility in off-street parking requirements or mixed use development. In a greenfield development, hybrid coding is oriented more toward place making because there are no surrounding developments and fewer—or no—established design traditions. Here, the hybrid code sets the tone for the first development and for all that follow.

In a way, it can be easier to define the policy for an area of preservation because the guiding principles are already on the ground. Place making in greenfield environments

ability and the ability to “look through” a block by keeping front yards unobstructed by fences, hedges, and even automobiles.

Step 3: Describe the Form

Any zoning process, including hybrid coding, should involve the public at all points in the process. However, public involvement at step three is crucial. Residents generally know what they like in terms of physical form, but have very different ways of articulating that idea. In addition, they often react to perception rather than reality. A building height of three stories means—and implies—a lot of different things to a lot of different people.

Before moving to step four and drafting regulations, the goal is to have everyone speaking the same language. Visual preference surveys, open houses, and public workshops—often conducted more than once—are good ways to elicit public consensus on specific design elements. For example, residents can use these forums to point out which buildings within the district provide the proper architectural context. Further, they can cite specific character-giving elements, like fenestration design, desired roof form, and preferred building materials, that they would like to be part of the regulations.

The educational aspect of step three cannot be overstated. To continue the previous example, some residents may resist the idea of a three-story building height when described as 35 feet, but they may not be aware that many of character-defining buildings in the downtown are already 35 feet in height. In another example, if a community wants to use hybrid coding for single-family infill, it needs to determine what residents find troublesome about new development.

In many cases, this boils down to a discussion of design versus scale. Planners should work with the public to determine what is at the core: Is it the architectural design of new buildings? The building materials being used? Or is it the scale of new construction and the impact on adjacent, existing residences? At this point in the process, it is important for the community to get at the true motivations and concerns of its residents in order to understand what really needs to be regulated.

For both zoning updates in Riverside, the village provided a number of opportunities for public participation. The plan commission and village staff identified the initial set of zoning issues to be addressed, but once these were identified, Riverside held public open houses,

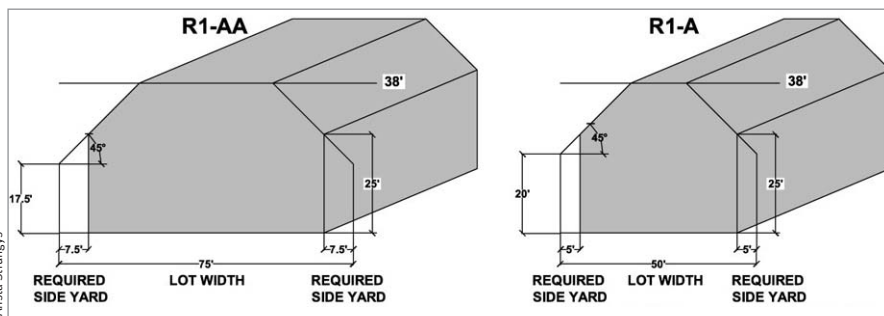

When the scale of new development is at issue, communities may need to shape the building envelope to prevent a “canyon effect” and maintain proper light and air between developments. This illustration shows how a new residential development that wants to exceed established sidewall heights would have to provide a larger side setback to preserve proper spacing between residences.

comprised of single-family residential, the hybrid coding process was issue oriented (i.e., ensuring that new residential development maintain the established character) rather than being driven by a need to define community character.

Step 2: Set the Policy

Before creating specific regulations, communities must confirm the development policies and concepts that will guide the drafting process. Often these policies come from recently adopted plans, like a comprehensive plan or downtown plan. Regardless of whether a community has articulated development policy through an adopted plan or if it uses the zoning process to determine that policy, communities need to focus on the following question: Is the driving goal one of place making or preservation?

requires more detailed concepts prior to drafting the regulations, because there is no surrounding context. The first new development also takes on additional significance because it sets the tone for all that follows.

The entire Village of Riverside is a National Historic District, so both the CBD and residential zoning assignments were focused on preservation. The goal was to create zoning districts consistent with Olmsted’s vision. Because original zoning regulations addressed all commercial areas under one classification, the village needed to create a “concept plan” to determine the goals for future development in the historic business core and to outline those elements of building form and site layout that define the CBD. For the residential districts, the goal was to require new development to maintain the established character, such as front yard vari-

typically on weekends, so that residents could understand the full range of issues being addressed and provide input into the different regulatory approaches. The village used visual preference surveys to gain a better understanding of what residents did and did not like. After the new codes were drafted, Riverside opened up all ordinance review meetings to the public to allow for continued input. For the residential revisions alone, more than 20 public meetings were held with the plan commission before the public hearing on the final ordinance.

what is *encouraged*. The second task is to determine how specific or broad each standard should be.

It is often easier to tell an applicant that he or she must do something, rather than attempt to persuade an applicant that adding a certain design element is recommended. The benefit of a requirement—a “must”—is that the expected form is more predictable and less review time is needed because it is an issue of compliance, rather than negotiation. The downside is that a requirement may be met with resistance from property owners,

is expected and no cohesive look to the resulting development. This negates the purpose of form-based controls.

Finally, it is important for a community to remember the type of development it is planning for and to ensure that regulations do not exclude specific development types that may be desired, even if they are not the predominant form. If traditional residential development includes tall homes in the Victorian style, the code can be tailored to specifically address these architectural forms as exceptions without setting a height limit that leads to out-of-scale modern development that towers over its neighbors.

In order to preserve the historic development pattern within the village, Riverside established strict setback controls for both the CBD and the residential districts. In the CBD, the village created parcel-by-parcel setbacks for each zoning lot, including a combination of minimum setbacks, maximum setbacks, and build-to lines, coupled with buffer yard requirements where lots abutted residential uses. In residential districts, in order to maintain the historic variability of the front setback, the concept of a street yard was created. Prior to the ordinance update, the village used an averaging provision. The dimension of the street yard—in more traditional zoning terms—is determined by the closest dimension indicated on the Works Progress Administration (WPA) House Setback Survey. The WPA undertook a House Setback Survey in Riverside between 1936 and 1953 to document building placement on Riverside’s lots. The information contained in this survey, available from the village building department, is used to determine the street yard dimension. Because Riverside historically has a varied front setback, using the map allows the village to maintain the historic development pattern and front yard variability.

Some districts were also more amenable to strict controls than others. Within the CBD, there are very specific design standards for new construction, including permitted building materials and standards for scale, massing, and fenestration, including an illustrative guide of contextual architecture. Because the CBD is a concentrated area with a clearly established historic character, the majority of regulations are “musts.” However, within the residential districts, the village drafted design standards to address only the specific elements that were identified as the most vulnerable to permitting out-of-character construction, such as building

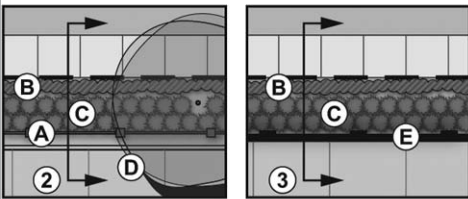
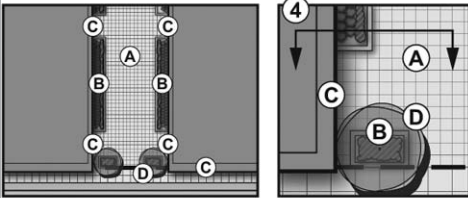
Secondary Street Landscape Area:		
		<ul style="list-style-type: none"> (A) 4' ornamental fence along surface parking lots (B) 2' min. width for groundcover (C) 4' wide min. Low Hedge row (D) Large Deciduous Trees 25' O.C. along surface parking lots (E) Parking Structures
Plaza Area:		
		<ul style="list-style-type: none"> (A) Decorative paving pattern (B) 2' high min. Raised Planter with 4' wide min. Low Hedge row and 2' min. width for groundcover (C) Building access points (D) Small Ornamental Trees at Plaza Area entrance
<p>☞ When creating a hybrid code it is also important to look at the various site elements—parking, signs, and landscaping—so that they work in concert with the desired building form. In this example, the community included landscaping standards for frontage along a right-of-way as well as within a required plaza area.</p>		

Arista Stungys

With any design-oriented process, the use of illustrations and photos is necessary to communicate design concepts and policy ramifications. Open houses provide an important opportunity to illustrate what is currently permitted under existing regulations and to solicit input on proposed changes. For example, in Riverside, the controversy centered around the maximum building height for the CBD. Many residents believed that the proposed three-story height was too tall. Only after the village illustrated how that height matched existing development within the CBD was the issue resolved.

Step 4: Balance the Regulations

Once the various elements of the desired form are identified, specific regulations can be drafted. First, planners need to balance what *must* (a requirement) be done versus

developers, architects, and others during the code-drafting process, and may lead to increased variance applications after code adoption. When design elements are simply encouraged, the code provides more flexibility and tends to calm the nerves of those who fear the “architecture police,” but if too many elements are only encouraged, communities have no way to guarantee the desired end product.

The specificity of the controls, whether required or encouraged, is another difficult situation for any community to navigate. If the controls are very specific, the developer knows exactly what is expected and can plan accordingly. But if the standards are too specific, with limited alternatives, the outcome can produce cookie-cutter development. On the other hand, if the standards are left too broad, then there can be confusion over what

materials, garages, and a building height setback plane. The village did not want to control residential architecture and require design review for each new structure.

Step 5: Administer and Implement the Code

The final step is to create the tools to administer and implement the hybrid code. This should begin with an assessment of the capacity and expertise of both staff and the various boards and commissions to determine who is best able to review the applications.

There are a number of options to put a hybrid code into action. One of the most basic is the site plan review process. Generally, site plan review addresses the different aspects of site design (e.g., circulation, parking, landscaping, and open space, etc.), but communities can expand this process to include building design review that originates from the form-based controls in the code.

Implementing a hybrid code through the site plan review process requires consideration of who reviews the applications. The

Implementing a hybrid code through the site plan review process may also increase the number of applications seen by the review body, depending on what districts or development types have received form-based treatment. For example, if single-family infill is now subject to significant form-based controls, then the site plan review body, depending on the development activity in the area, may see its workload double or even triple. If the area is active, a separate committee and review process may be necessary just to accommodate the number of applications in a timely manner. This is especially true if site plan review is handled by a body like the plan commission, which already has a number of other duties.

One option outside of site plan review is to create a design review process. A design review committee, comprised of community members (including some with specific design expertise), would analyze each application for compliance with the intent of the regulations. If the hybrid coding is only

alternatives, there will be a more subjective interpretation. Staff may not be comfortable making these subjective decisions and a public committee may be necessary.

As the community formulates its standards and considers the review process, the key issues to keep in mind are: capacity, efficiency, expertise, and consistency. In other words, the jurisdiction needs to review each application and render a decision within a reasonable time frame. The outcome should be predictable, and the review body should be consistent in the application of standards and decisions.

Because Riverside’s original ordinance dated from 1922, there were no review processes in place that could evaluate development applications against the new standards. Therefore, as part of the creation of the CBD zoning district, the village established a site plan review procedure. The updated zoning put the plan commission in charge of reviewing and approving site plan applications. Because of the small size of the village core and the expertise of plan commission members, integrating application review as a member responsibility proved to be an effective and efficient way to administer the new design-oriented regulations for the CBD. Because residents are very concerned about the character of new development, the plan commission’s review also allows for transparency in the development approval process.

When Riverside initially discussed design standards for new residential development, the village worried it would need a design review committee to assist in review of those applications. However, because the design standards were restricted to a series of requirements that must be met, the need for such a committee became unnecessary. Staff could continue to process applications as they came in for compliance with new form-based regulations.

THE TRANSITION

As new rules affecting the design and placement of buildings are integrated with use and bulk controls, it is important for a community to agree upon urban design goals or guidelines and to illustrate how form-based regulations within a revised zoning code can help to advance the design vision. The result of this, however, may be the creation of nonconformities. It is helpful in these instances to provide that existing structures are “deemed conforming.” This type of provision should not be

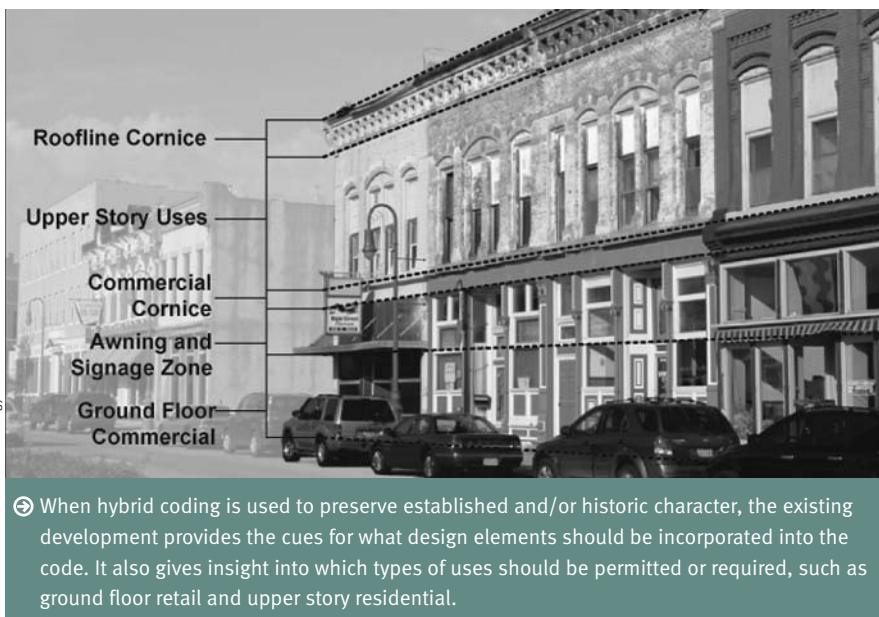

review body must be comfortable with this added layer of responsibility. If the site plan review process is conducted internally by staff, they may be comfortable making site plan assessments but uncomfortable with interpreting architectural standards, which may require additional expertise. In this situation, it may be appropriate to conduct the site plan review through staff and forward the comments to another committee for design review.

applied to a certain areas, staff can conduct an internal site plan review and forward their report to the design review committee to be integrated at the end of the process as one comprehensive review report.

If requirements are strict, staff can review the applications and expedite the process by checking for compliance. If more standards are encouraged and require negotiation for their inclusion in a design, or if the standards are very broad or offer a number of

◆ **Oklahoma City, Oklahoma: Zoning Ordinance**

Design guidelines as well as site-specific yard and bulk regulations, are combined with traditional zoning controls to guide the form and character of new development in Oklahoma City’s Downtown Business District, Downtown Transitional District Limited, and Downtown Transition District General. These regulations are interpreted and enforced via a downtown design review certificate of approval for all projects, whether public or private.

◆ **Noblesville, Indiana: Corporate Campus**

The Corporate Campus Plan and Development Regulations, which covers nearly six square miles, lays out recommendations for land-use and transportation improvements. Further, it contains detailed development policy and urban design guidelines to assure that the character of new development meets the expectations and values of the community. This is achieved through the provision of an overall land-use plan, a set of land-use and urban design policies, and design guidelines that are depicted in the form of several illustrative plans designed to give developers a clear statement of the community’s intent. The implementation of this plan is governed by a specific design set of zoning controls which are incorporated in a Corporate Campus Zoning District.

◆ **Park Ridge, Illinois—Zoning Ordinance**

The B-4 Uptown Business District is intended to sustain the current commercial, pedestrian-oriented character, and economic viability of the central business district. Hybrid coding is used to ensure that new development is consistent with Uptown’s established scale, architecture, and mix of uses. In order to refine the regulations for this district, a series of subdistricts have been created with distinct use and bulk regulations.

applied to every nonconformity, because many may be undesirable and should be eliminated. It is, however, a useful tool to help preserve existing structures that may violate existing code requirements but that have distinct character-giving elements in the community.

For example, new residential height restrictions may make certain homes with more elaborate roof forms nonconforming because of maximum height violations, but keeping the old height restrictions may lead to undesirable residential infill that is out of character and out of scale. The solution may be to tailor the height restrictions to prevent the out-of-scale construction but deem the existing structures, which violate that restriction, conforming. In all cases, a “deemed conforming” provision should be very specific in application and carefully considered before codification.

Riverside’s original ordinance used an interior residential height measurement that did not regulate overall building height. Because building height is a key bulk control, part of the update established both a set building height and a building height setback plane. Together, these controls manage the scale and volume of new construction. Because the new ordinance includes a definitive building height that could result in taller

The solution may be to tailor the height restrictions to prevent the out-of-scale construction but deem the existing structures, which violate that restriction, conforming.

buildings, the village wanted to control overall volume with a setback plane. The actual dimensions of these regulations were based upon the predominant design characteristics of existing homes. For example, most homes of the desired scale had a sidewall height of approximately 23 feet. Therefore, at the minimum side yard setback, the building height setback plane permits 23 feet as the maximum sidewall height at the minimum side yard setback. If a higher sidewall height is desired, the builder must provide a larger side yard setback.

In addition, the new controls allowed dormers and gables, common to Riverside’s residential architecture, to pierce this envelope. However, with new restrictions on building height, the village was concerned that a number of existing homes, many of which could be historic, violated the new restrictions. Rather than treat these existing homes as nonconformities, which by definition are intended for gradual elimination, all homes that existed on the date of adoption of the ordinance that did not comply with the building height restrictions were deemed conforming to encourage their preservation.

THE BEST OF BOTH WORLDS

A hybrid code incorporates the best of both worlds. Form-based elements target areas that need refined design regulation, while those parts of the code that work remain as they are. The public process elicits design controls that are supported and desired by the community, and creates a code understood and trusted by residents. By keeping what works and using form-based techniques to target specific areas or issues, a traditional zoning code can achieve the same results as a form-based code without having to start from scratch.

Neighborhood Center Standards from the City of Grass Valley, California, Development Code. Cover concept by Lisa Barton. Image courtesy of Opticos Design, Inc. and Crawford, Multari & Clark Associates.

VOL. 25, NO. 5

Zoning Practice is a monthly publication of the American Planning Association. Subscriptions are available for \$75 (U.S.) and \$100 (foreign). **W. Paul Farmer, FAICP, Executive Director; William R. Klein, AICP, Director of Research.**

Zoning Practice (ISSN 1548-0135) is produced at APA. **Jim Schwab, AICP, and David Morley, Editors; Julie Von Bergen, Assistant Editor; Lisa Barton, Design and Production.**

Copyright ©2008 by American Planning Association, 122 S. Michigan Ave., Suite 1600, Chicago, IL 60603. The American Planning Association also has offices at 1776 Massachusetts Ave., N.W., Washington, D.C. 20036; www.planning.org.

All rights reserved. No part of this publication may be reproduced or utilized in any form or by any means, electronic or mechanical, including photocopying, recording, or by any information storage and retrieval system, without permission in writing from the American Planning Association.

Printed on recycled paper, including 50-70% recycled fiber and 10% postconsumer waste.



ZONING PRACTICE
AMERICAN PLANNING ASSOCIATION

122 S. Michigan Ave.
Suite 1600
Chicago, IL 60603

1776 Massachusetts Ave., N.W.
Washington D.C. 20036



HOW CAN YOUR COMMUNITY INCLUDE FORM CONTROLS IN A CONVENTIONAL ORDINANCE?

5

