

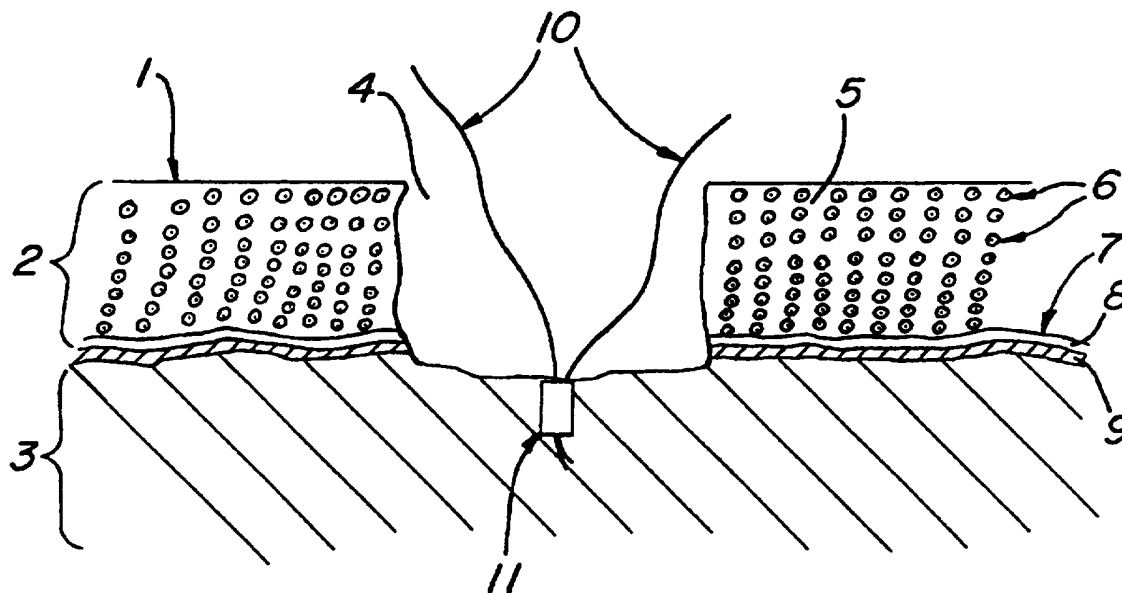

INTERNATIONAL APPLICATION PUBLISHED UNDER THE PATENT COOPERATION TREATY (PCT)

<p>(51) International Patent Classification ⁶ : A61B 19/00</p>	<p>A1</p>	<p>(11) International Publication Number: WO 96/24304 (43) International Publication Date: 15 August 1996 (15.08.96)</p>
<p>(21) International Application Number: PCT/US96/01742 (22) International Filing Date: 8 February 1996 (08.02.96) (30) Priority Data: 08/386,799 10 February 1995 (10.02.95) US (71) Applicant: THE HOSPITAL FOR JOINT DISEASES, ORTHOPAEDIC INSTITUTE [US/US]; 301 East 17th Street, New York, NY 10003 (US). (72) Inventors: PACHENCE, James, M.; 18 Elm Street, Hopewell, NJ 08525 (US). FRENKEL, Sally; 73-10 137th Street, Flushing, NY 11367 (US). MENCHE, David; 530 East 76th Street, New York, NY 10021 (US). (74) Agent: BERNSTEIN, Alan, H.; Caesar, Rivise, Bernstein, Cohen & Pokotilow, Ltd., Seven Penn Center, 12th floor, 1635 Market Street, Philadelphia, PA 19103-2212 (US).</p>		<p>(81) Designated States: AL, AM, AT, AU, AZ, BB, BG, BR, BY, CA, CH, CN, CZ, DE, DK, EE, ES, FI, GB, GE, HU, IS, JP, KE, KG, KP, KR, KZ, LK, LR, LS, LT, LU, LV, MD, MG, MK, MN, MW, MX, NO, NZ, PL, PT, RO, RU, SD, SE, SG, SI, SK, TJ, TM, TR, TT, UA, UG, UZ, VN, ARIPO patent (KE, LS, MW, SD, SZ, UG), Eurasian patent (AZ, BY, KG, KZ, RU, TJ, TM), European patent (AT, BE, CH, DE, DK, ES, FR, GB, GR, IE, IT, LU, MC, NL, PT, SE), OAPI patent (BF, BJ, CF, CG, CI, CM, GA, GN, ML, MR, NE, SN, TD, TG).</p> <p>Published <i>With international search report.</i></p>

(54) Title: FIXATION METHOD FOR THE ATTACHMENT OF WOUND REPAIR MATERIALS TO CARTILAGE DEFECTS



(57) Abstract

An attachment method to hold a biomaterial in place until healing occurs. The method consists of anchoring sutures (10) through the subchondral plate (9) into bony tissue with at least two lines (10) emerging from the surface. The anchored suture lines (10) are then pulled through the implant at its four quadrants, and is thus used to secure the cartilage repair material into the wound site.

FOR THE PURPOSES OF INFORMATION ONLY

Codes used to identify States party to the PCT on the front pages of pamphlets publishing international applications under the PCT.

AM	Armenia	GB	United Kingdom	MW	Malawi
AT	Austria	GE	Georgia	MX	Mexico
AU	Australia	GN	Guinea	NE	Niger
BB	Barbados	GR	Greece	NL	Netherlands
BE	Belgium	HU	Hungary	NO	Norway
BF	Burkina Faso	IE	Ireland	NZ	New Zealand
BG	Bulgaria	IT	Italy	PL	Poland
BJ	Benin	JP	Japan	PT	Portugal
BR	Brazil	KE	Kenya	RO	Romania
BY	Belarus	KG	Kyrgyzstan	RU	Russian Federation
CA	Canada	KP	Democratic People's Republic of Korea	SD	Sudan
CF	Central African Republic	KR	Republic of Korea	SE	Sweden
CG	Congo	KZ	Kazakhstan	SG	Singapore
CH	Switzerland	LI	Liechtenstein	SI	Slovenia
CI	Côte d'Ivoire	LR	Liberia	SK	Slovakia
CM	Cameroon	LK	Sri Lanka	SN	Senegal
CN	China	LT	Lithuania	SZ	Swaziland
CS	Czechoslovakia	LU	Luxembourg	TD	Chad
CZ	Czech Republic	LV	Latvia	TG	Togo
DE	Germany	MC	Monaco	TJ	Tajikistan
DK	Denmark	MD	Republic of Moldova	TT	Trinidad and Tobago
EE	Estonia	MG	Madagascar	UA	Ukraine
ES	Spain	ML	Mali	UG	Uganda
FI	Finland	MN	Mongolia	US	United States of America
FR	France	MR	Mauritania	UZ	Uzbekistan
GA	Gabon			VN	Viet Nam

**FIXATION METHOD FOR THE ATTACHMENT
OF WOUND REPAIR MATERIALS TO CARTILAGE DEFECTS**

SPECIFICATION

FIELD OF THE INVENTION

This invention is within the technical fields of surgery, medicine, tissue engineering, biology, biomaterials, polymers, and biochemistry. It is both a product and a method of use for the repair of cartilage lesions, with and without the use of chondrocytes cultured *in vitro*.

BACKGROUND

It has been well documented that injured articular cartilage has only a limited ability for self-repair. As articular cartilage is relatively avascular and aneural, loss of the surface tissue will result in a permanently scarred site; lesions which fracture the subchondral bone which has a greater vascular supply will undergo an inflammation/repair response, with the damaged site filling with fibrocartilage tissue (Convery, *et al.* 1972). In either case, function is impaired and chronic pain is the usual prognosis as the biochemical and biomechanical characteristics of the cartilage have been altered. Current treatment protocols call for surgical intervention (such as abrasion arthroplasty, excision and drilling, articular cartilage debridement, and arthroscopic shaving) and will most often lead again to inadequate repair. Long-term morbidity such as degeneration to arthritic conditions will often result in patients with chronic cartilage problems.

Nevertheless, articular cartilage theoretically does have some intrinsic ability to heal after injury. For example, chondrocytes are capable of replication when isolated enzymatically from the cartilage matrix (Grande, *et al.* 1989). It has been suggested that cartilage repair can be initiated by either replication of chondrocytes in the regions adjacent to the defect, or by metaplasia of chondrocytes from other connective tissue stem cells within the joint capsule, such as from the synovium and subchondral bone (Sokoloff, 1978). Given this possibility, investigations of autograft or allograft tissue and tissue analogues to heal cartilage lesions has progressed.

Techniques were developed to utilize autologous tissue, such as transplantation of: 1) osteochondral grafts (DePalma, *et al.* 1963); 2) chondrocytes (Grande, *et al.* 1989); 3) periosteum (Homminga, *et al.*, 1990); and 4) demineralized bone (Dahlberg and Kreicbers, 1991). These techniques have been used to transplant

attempted to heal cartilage defects using chondrocytes isolated from epiphysial plates, as well as articular cells, with the hypothesis that these cells would have a greater chance of success due to their heightened metabolism (Itay, *et al.* 1987). Clinical studies using cultured cells reported excellent results, showing a significant decrease in pain and restoration of normal function after two to four years post-op (Iloika, *et al.* 1990; Ilomminga, *et al.* 1990).

Other investigators have used a combination of materials and autologous tissue to effectively repair cartilage defects, such as: 1) demineralized bone with perichondrium (Billing, *et al.*, 1990) 2) polylactic acid matrices and periosteal graft (von Schroeder, *et al.* 1991); and 3) bioresorbable meshes and chondrocytes (Freed, *et al.* 1993). Although these approaches gave repair tissue that more closely resembled normal cartilage than either the unfilled sites, or the sites filled with materials alone, it was evident that there was again a substantial amount of fibrocartilage formation.

To date, the limited success of articular cartilage repair is in part due to the lack of suitable methods for internal surgical fixation. The initial technique used by Grande, *et al.* 1989, calls for suturing a periosteal flap into place. A piece of periosteum was freshly isolated from the proximal tibia, and sutured to the periphery of the patella defect with 9-0 Vicryl sutures. This technique has been found to be surgically cumbersome, and limiting with respect to the size and placement of the defect. A number of authors have used a press fit technique to secure an implant into a cartilage defect site (*e.g.*, Coutts, *et al.* 1994; Freed, *et al.* 1993; Nixon, *et al.* 1994). While this technique may work in non-weight bearing conditions, it is possible that the implant can dislodge during motion, especially during the first two weeks after implantation. In addition, there is limited flexibility to adjust the height of the implant with respect to the articular cartilage surface using a press fit technique.

OBJECTS OF THE INVENTION

Accordingly, it is a general object of this invention to provide a method of securing a multi-staged collagen implant to repair cartilage lesions which overcomes the disadvantages of the prior art.

It is a further object of this invention to provide a method of securing a multi-staged collagen implant to repair cartilage lesions which is effective and safe.

It is another object of this invention to provide method of securing a multi-

staged collagen implant to repair cartilage lesions which have resorbable components.

SUMMARY OF THE INVENTION

An attachment method is used to hold a cartilage repair template into a cartilage defect site. The method consists of the steps of anchoring sutures through the subchondral plate into bony tissue, with two or more lines emerging from a surface thereof. The anchored suture lines are used to secure the cartilage repair template to the site.

DESCRIPTION OF THE DRAWINGS

Other objects and many attendant features of this invention will become readily appreciated as the same becomes better understood by reference to the following detailed description when considered in connection with the accompanying drawings wherein:

Figure 1 shows the anatomy of normal cartilage and a defect or wound site 4 in which the following reference characters appear:

1 representing the articular surface, 2 hyaline cartilage 3 cancellous bone and marrow, 4 defect, 5 extracellular matrix, 6 chondrocytes, 7 tidemark, 8 calcified cartilage and 9 the subchondral plate.

Figure 2 shows an anchor 11 with attached suture lines 10 embedded into the bone 3 at the defect site 4.

Figure 3 shows the positioning of the collagen template 12 with the porous collagen matrix 13 and the dense collagen membrane 14 in threading the anchored sutures 10 through the template 12.

Figure 4 shows the positioning of a top protective layer 15 in securing this layer 15 and template 12 with anchoring sutures 10.

DESCRIPTION OF THE PREFERRED EMBODIMENTS

The advantage of the anchoring invention is that it secures an implant 12 to the site 4 of cartilage regeneration and prevents migration, as demonstrated in a canine model of cartilage repair under load-bearing conditions. Preventing migration is important because not only is the tissue regeneration aspect of the implant required at the site, but also because the biomechanics of the joint would not be disrupted by an object that partly or totally obstructs smooth motion of the joint. Another advantage of the invention is that it overcomes the press-fit size limitation of the defect to be treated.

Anchors have been used in the past to secure soft tissue to bone, particularly muscle, ligaments, and tendon in and around joints. The anchors are made from biocompatible metals and plastics and are available in a variety of sizes. It was found that suture materials can be secured to the distal aspect of the anchor, prior to placing the anchor into the defect site. A drill hole, is made at the approximate center of the defect. The anchor is then set into the prepared site, allowing the suture lines to freely extend away from the articular surface of the joint.

EXAMPLES OF INVENTION USE

1. Prepare a surgically defined site 4, slightly smaller than the size of the cartilage repair implant or template 12.
2. Drill an appropriately sized hole, (e.g., 1 mm in diameter) approximately in the center of the defect site 4. The hole should be of a sufficient diameter to allow the anchor 11 to be set into place and to permit the passage of a suture 10 therethrough.
3. Attach the appropriate number of sutures 10, e.g., two sutures to an anchor 11 (e.g., product sold as product number Mitek No. 210193 G-II MINI ANCHOR, sold by Mitek Surgical Products, Inc., Norwood, MA, as also disclosed in U.S. Patent Nos. 4,898,156 and 4,946,468, the entire disclosures of which are incorporated by reference herein), so that equal sized strands emanate from the distal aspect of the anchor 11, e.g., four. The sutures 10 should be bioresorbable, and should be sized 5-0 or less.
4. Set the anchor 11 into the drill hole, so that the resorbable suture strands 10 protrude from the center of the surgically prepared site, e.g., four (Figure 2).
5. Pull the suture lines through the cartilage repair implant 12 (Figure 3).
6. Tie the sutures so that the knot is buried beneath the implant surface or beneath the protective cover, if utilized), and not exposed to the articular surface 1 (Figure 4).

Defects in articular cartilage can be healed by utilizing a regeneration template formed by combining a porous collagen sponge ("collagen matrix") with a dense collagen membrane as described in our copending application entitled A Multi-staged Collagen-Based Template Or Implant For Use In The Repair of Cartilage Lesions,

the entire disclosure of which is incorporated by reference herein. The dense collagen matrix is made with a pore size of less than 1 micrometer, and is cross-linked with a non-cytotoxic agent to increase strength and lengthen resorption time. Because of this dense collagen membrane, the invention can be used in full-thickness defects, including those which traverse the subchondral plate. The dense collagen membrane is placed on the surface of the cartilage defect to prevent cell migration from the subchondral plate and vasculature. The collagen membrane will allow movement and exchange of fluids, nutrients, cytokines and other factors necessary for cartilage regeneration. The thicknesses of the components of the template 12 can vary depending upon the circumstances of use. For example, the thickness of the dense collagen membrane may be in the range of 50 to 200 micrometers or more and the thickness of the porous collagen matrix may be in the range of 0.5 to 8 millimeters or more.

The collagen matrix component of that template has been developed to allow attachment and growth of cells, particularly chondrocytes. *In vitro* studies have been used to determine the optimal pore size of the porous collagen matrix component of the template. The collagen matrix can be used to immobilize chondrocytes *in vitro* and support subsequent cell growth. The cell number can then be expanded *in vitro*, and the collagen matrix can be used to transport the cells to the repair site and retain the cells in position following implantation.

Previous studies have shown that the collagen matrix pore size can be controlled by varying the dispersion pH, collagen concentration and the lyophilization cycle (freezing time, temperature range, and cycle time (Dillion *et al.* 1986)). The collagen matrices have also been characterized according to their permeability to globular macromolecules. For example, it was found that a pore structure of approximately 15 micrometers would exclude molecules greater than 10^6 daltons; a dense collagen membrane had a molecular weight exclusion of 7×10^4 daltons (Li, 1987). Chondrocytes were grown on type I collagen matrices of varied pore structure in order to determine the effect of the average matrix pore size on cellular growth rate. It was found that the pore structure did not affect the rate of cell growth after 12 days. However, chondrocyte infiltration was greater for average pore sizes greater than 100 micrometers. A parallel study using fibroblasts showed similar cell growth results. It is important to note that the growth rate of fibroblasts on the dense collagen membrane

was approximately the same as a porous matrix, but that migration of cells through the membrane was excluded (Pachence *et al.*, 1991).

The dense collagen membrane can be attached to the collagen matrix prior to cell culture or prior to implantation, using: 1) bioresorbable sutures; or 2) a fusing technique, requiring that the dense collagen membrane be incorporated into the collagen matrix during formation.

It has been shown through a series of *in vivo* studies that the template with and without the addition of chondrocytes promotes the healing of surgically induced full thickness defects in a rabbit model of cartilage damage. The chondrocyte-seeded templates have been proven, through the use of histologic, biochemical, and mechanical analyses of retrieved implant-tissue sites, to result in repair tissue which appears to be hyaline cartilage. The orientation of the template in the cartilage defect is fundamental to achieve a successful result. The dense layer is placed "downward" into the defect, contacting bone, and the porous layer lies in the place of the natural cartilage. The dense layer has been shown experimentally to inhibit the formation of fibrocartilage.

Without further elaboration the foregoing will so fully illustrate our invention that others may, by applying current or future knowledge, adapt the same for use under various conditions of service.

The following publications involve some of the experiments used in testing portions of the invention, without disclosing the multi-stage device.

1. Grande, Vachon; Repair of induced osteochondral defects with a composite chondrocyte/collagen allograft in dogs. Transactions of the Combined Meeting of the Orthopaedic Research Societies of USA, JAPAN, and CANADA, October 21-23, 1991, Banff, Alberta.
2. Pachence, Frenkel, Lin: Development of a tissue analog for cartilage repair. In: Tissue Inducing Biomaterials (Cima, Ron, eds.) Materials Research Society Press, Pittsburgh, 1991.
3. Ahmad, Frenkel, Casar, and Alexander; A mechanical testing technique for articular cartilage; a study of intrinsic repair, In: Advances in Bioengineering (Bidez, ed.) ASME, New York, pp 245-251, 1991.
4. Frenkel, Pachence, Alexander; Optimization of a cell-seeded collagen implant for cartilage repair. Transactions of the Orthopaedic Research Society 18:730, 1993.
5. Toolan, Frenkel, Pachence, Yalowitz, Ahmad, Casar; In vitro characterization of a collagen chondrocyte composite matrix for cartilage repair, Transactions of the Society for Biomaterials 17:313, 1994.
6. Toolan, Frenkel, Pachence, Yalowitz and Alexander: An analysis of a chondrocyte-collagen implant for cartilage repair. Journal of Bone and Joint Surgery, abstract in press.
7. Frenkel, Pachence, Toolan, Menche, Pitman, Crawford, Steger; Evaluation of a novel two-layered collagen implant for articular cartilage repair in a rabbit model. Journal of Bone and Joint Surgery, abstract in press (to be presented at the Annual Meeting of the Orthopaedic Research Society, Orlando, 1995).

Other referenced articles:

8. Amiel, Coutts, Harwood, Ishizue, and Kleiner: The Chondrogenesis of Rib Perichondrial Grafts for Repair of Full Thickness Articular Cartilage Defects in a Rabbit Model, Connective Tissue Research

- 18:27-39 (1988).
9. Athanasiou, Schmitz, Schenck, Clem, Aufdermorte, Boyan: The Use of Biodegradable Implants for Repairing Large Articular Cartilage Defects in the Rabbit. Transactions of the 38th Annual Meeting of the ORS, p. 172, (1992).
 10. Bentley, Smith and Mukerjee, Isolated Epiphyseal Chondrocyte Allografts into Joint Surfaces; An Experimental Study in Rabbits. Ann. Rheum. Dis. 37;449-458 (1978).
 11. Billings, von Schroeder, Mai, Aratow, Amiel, Woo, and Coutts; Cartilage resurfacing of the rabbit knee. Acta Orthop. Scand. 61(3); 201-206 (1990).
 12. Convery, Akeson, Keown; The Repair of Large Osteochondral Defects, Clinical Orthopedics and Related Research 82:253-262 (1972).
 13. Coutts, Yoshioka, Amiel, Hacker, Harwood, and Monosov; Cartilage repair using a porous polylactic acid matrix with allogeneic perichondrial cells. Transactions of the 40th Annual Meeting of the ORS, 1994.
 14. Dahlberg and Kreicbergs; Demineralized Allogeneic Bone Matrix for Cartilage Repair, J. Orthop. Research 9:11-19 (1991).
 15. DePalma, Tsa-Hos, and Maaler; Viability of Osteochondral Grafts as Determined by Uptake of S³⁵, J. Bone Joint Surg. 45A:1565-1578 (1963).
 16. Freed, Marquis, Nohria, Emmanuel, Mikos and Langer; Neocartilage formation in vitro and in vivo using cells cultured on synthetic biodegradable polymers. Journal of Biomedical Materials Research 27:11-23 (1993).
 17. Grande, Pitman, Peterson, Menche and Klein: The repair of experimentally produced defects in rabbit articular cartilage by autologous chondrocyte transplantation. Journal of Orthopedic Research 7:208-218 (1989).
 18. Hogervorst, Meijer and Klopper: The effect of a TCP-collagen

- implant on the healing of articular cartilage defects in the rabbit knee joint. *Journal of Applied Biomaterials* 3:251-258 (1992).
19. Hoikka, Jaroma and Ritsila, Reconstruction of the Patellar Articulation with Periosteal Grafts, *Acta Orthop. Acad.* 61:36-39 (1990).
 20. Homminga, Bulstra, Bouwmeester and Van Der Linden; Perichondral Grafting for Cartilage Lesions of the Knee. *The Journal of Bone and Joint Surgery* 72:1003-1007 (1990).
 21. Hunziker and Rosenberg; Induction of repair in partial thickness articular cartilage lesions by timed release of TGF β . *Transactions of the 40th Annual Meeting of the ORS, 1994.*
 22. Itay, Abramovici and Nevo; Use of cultured embryonal chick epiphyseal chondrocytes as grafts for defects in chick articular cartilage. *Clinical Orthopaedics and Related Research* 220:294-303 (July 1987).
 23. Kimura, Yasui, Ohsawa and Ono; Chondrocytes Embedded in Collagen Gels Maintain Cartilage Phenotype During Long-Term Cultures. *Clinical Orthopaedics* 186:231-239 (1984).
 24. Messner; Hydroxylapatite supported dacron plugs for repair of isolated full-thickness defects of the rabbit femoral condyle. *Transactions of the 40th Annual Meeting of the ORS, 1994.*
 25. Moran, Kim, Slater; Biological Resurfacing of Full-Thickness Defects in Patellar Articular Cartilage of the Rabbit. *Journal of Bone and Joint Surgery* 74:659-667 (1992).
 26. Nixon, Sams, Minor; Long-term Survival and Neocartilage Maturation Following Extensive Articular Resurfacing With Chondrocyte Laden Collagen Scaffolds, *Transactions of the 40th Annual Meeting of the ORS, 1994.*
 27. Nixon, Sams, Lust, Grande and Mohammed; Temporal Matrix Synthesis and Histological Features of a Chondrocyte-Laden Porous Collagen Cartilage Analogue, *American Journal of Veterinary Research* 54:349-356 (1993).

28. Nixon, Lust and Vernier-Singer; Isolation, Propagation, and Cryopreservation of Equine Articular Chondrocytes. *American Journal of Veterinary Research* 53:2364-2370 (1992).
29. Rich, Johnson, Zhou and Grande: The use of periosteal cell/polymer tissue constructs for the repair of articular cartilage defects. *Transactions of the 40th Annual Meeting of the ORS, 1994.*
30. Robinson, Efrat, Mendes, Halperin, Nevo; Implants composed of carbon fiber mesh and bone-marrow-derived chondrocyte-enriched cultures for joint surface reconstruction. *Bulletin of the Hospital for Joint Diseases* 53(1)1-8 (Spring 1993).
31. von Schroder, Kwan, Amiel and Coutts: The Use of Polylactic Acid Matrix and Periosteal Grafts for the Reconstruction of Rabbit Knee Articular Defects. *Journal of Biomedical Materials Research* 25:329-339 (1991).
32. Sokoloff: In Vitro Culture of Skeletal Tissues, Chapt, 1, in The Joints and Synovial Fluid (Vol. II), edited by L. Sokoloff (Academic Press, NY, 1978), pp. 1-27.
33. Vachon, McIlwraith, Powers, McFadden and D.Amiel: Morphologic and Biochemical Study of Sternal Cartilage Autografts for Resurfacing Induced Osteochondral Defects in Horses. *American Journal of Veterinary Research* 53:1039-1047 (1992).
34. Wakitani, Kimura, Hirooka, Ochi, Yoneda, Yasui, Owaki, Ono; Repair of rabbit articular surfaces with allograft chondrocytes embedded in collagen gel. *British Journal of Bone and Joint Surgery* 71-13;74-80 (1989).
35. Wakitani, Ono, Goldberg and Caplan; Repair of large cartilage defects in weight-bearing and partial weight-bearing articular surfaces with allograft articular chondrocytes embedded in collagen gels. *Transactions of the 40th Annual Meeting of the ORS, 1994.*
36. Weadock, Olson, Silver: Evaluation of Collagen Crosslinking Techniques, *Biomater. Med.Dev.Art. Org.* 11:293-318 (1983).

RELATED REFERENCES:

- US 4,458,678 Cell Seeding Procedures Involving Fibrous Lattices (Yannas and Burke)
- US 4,505,266 Cell Seeding Procedures Involving Fibrous Lattices (Yannas and Burke)
- US 4,846,835 Technique for healing lesions in cartilage (Grande)
- US 5,108,438 Prosthetic intervertebral disc acting as a regrowth scaffold (Stone)
- US 5,041,138 Formation of cartilage structures by attaching chondrocyte cells to biocompatible matrix in nutrient environment (Vacanti, *et al.*)
- US 5,206,028 Dense Collagen Membrane Matrices for Medical Use (Shu-Tung Li)
- US 5,053,050 Compositions for Repair of Cartilage and Bone (Itay)
- US 5,133,755 Method and Apparatus for Biodegradable Osteogenic Bone Graft Substitute Device (Brekke)
- US 5,206,023 Method and Compositions for the Treatment and Repair of Defects or Lesions in Cartilage (Hunziker)
- US 4,837,379 Tissue equivalent comprising fibrin containing hydrated collagen lattice contracted with e.g., fibroblasts, opt. in multilayer form, useful as organ or tissue replacements (Weinberg)
- WO 8907425 Medical use of amniotic cells or tissue for tissue regeneration, implant treatment, production of useful substances, detoxification of body fluids and skin or scalp treatment (Butler, *et al.*)
- E 277678 Graft for reconstructive surgery comprises pref. biodegradable prods. organic polymer matrix with bimodal pore size distribution (Nijenhuis, *et al.*)
- WO 8803785 Artificial matrix for controlled cell growth used for chimeric neomorphogenesis of organs by controlled cellular implantation (Vacanti & Langer)
- WO 8301384 Tissue generation at wounds by placing fibrous lattice in contact with wound and seeding lattice with cells (Yannas & Burke)

CLAIMS

We claim:

1. An attachment method used to hold a cartilage repair template (12) into a cartilage defect site, said method characterized by the steps of:
 - a) anchoring sutures (10) through the subchondral plate (9) into bony tissue, with at least two lines (10) emerging from a surface thereof; and
 - b) using the anchored suture lines (10) to secure the cartilage repair template (12) to the site.
2. The method of claim 1 further characterized by the step of selecting the cartilage repair template (12) to be a bilayer material (13, 14) for the repair of cartilage defects leading to the regeneration of hyaline-like cartilage, consisting of:
 - a) a first layer comprising a dense collagen membrane (14) having a pore size of less than 1 micrometer which is cross-linked with a non-cytotoxic agent to increase strength and lengthen resorption time, to provide a barrier against movement of cells from the subchondral plate, the membrane (14) being sufficiently permeable to allow the passage therethrough of fluids, nutrients, cytokines, and other endogenous factors necessary for healing; and
 - b) a second layer (13) secured to the first layer and comprising a porous collagen matrix having pore size of 50 to 200 micrometers, which permits the ingrowth of cells.
3. The method of claim 2 further characterized by the step of selecting the template (12) to comprise autologous periosteum (15) placed on top of the collagen matrix (13) and the matrix (13) is initially devoid of cells.
4. The method of claim 2 further characterized by the step of selecting the template (12) to comprise a collagen film placed on top of the collagen matrix (13) and the matrix is initially devoid of cells.
5. The method of claim 2 further characterized by the step of selecting the template (12) to comprise chondrocyte cells (6) cultured *ex vivo* with the porous collagen matrix (13) so that the chondrocytes (6) permeate the collagen matrix (13).
6. The method of claim 2 further characterized by the step of selecting

the template (12) to comprise a piece of autologous periosteum (15) placed on top of the collagen matrix containing the chondrocyte cells (6).

7. The method of claim 2 further characterized by the step of selecting the template (12) to comprise a collagen film placed on top of the collagen matrix (13) containing the chondrocyte cells (6).

8. The method of claim 2 further characterized by the step of attaching the dense collagen membrane (14) to the collagen matrix (13) using a resorbable suture.

9. The method of claim 2 further characterized by the step of incorporating the dense collagen membrane (14) is into the collagen matrix (13) during formation of the matrix.

10. The method of claim 2 further characterized by the step of selecting the dense collagen membrane (14) to have a thickness in the range of 50 to 200 micrometers.

11. The method of claim 2 further characterized by the step of selecting the porous collagen matrix (13) to have a thickness in the range of 0.5 to 8 millimeters.

FIG. 1

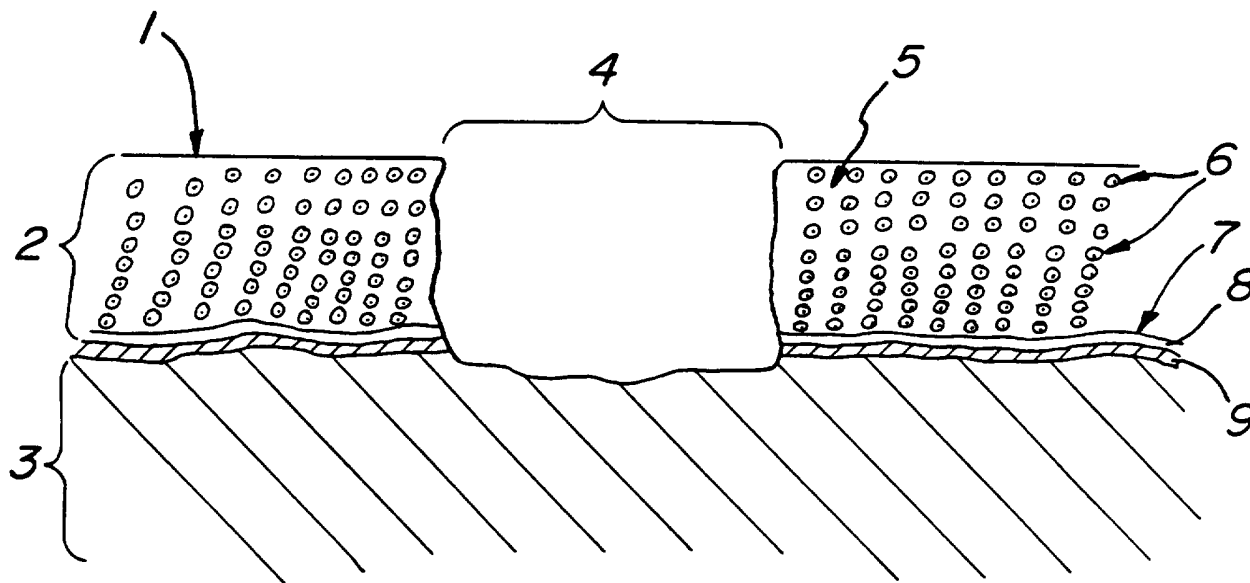

FIG. 2

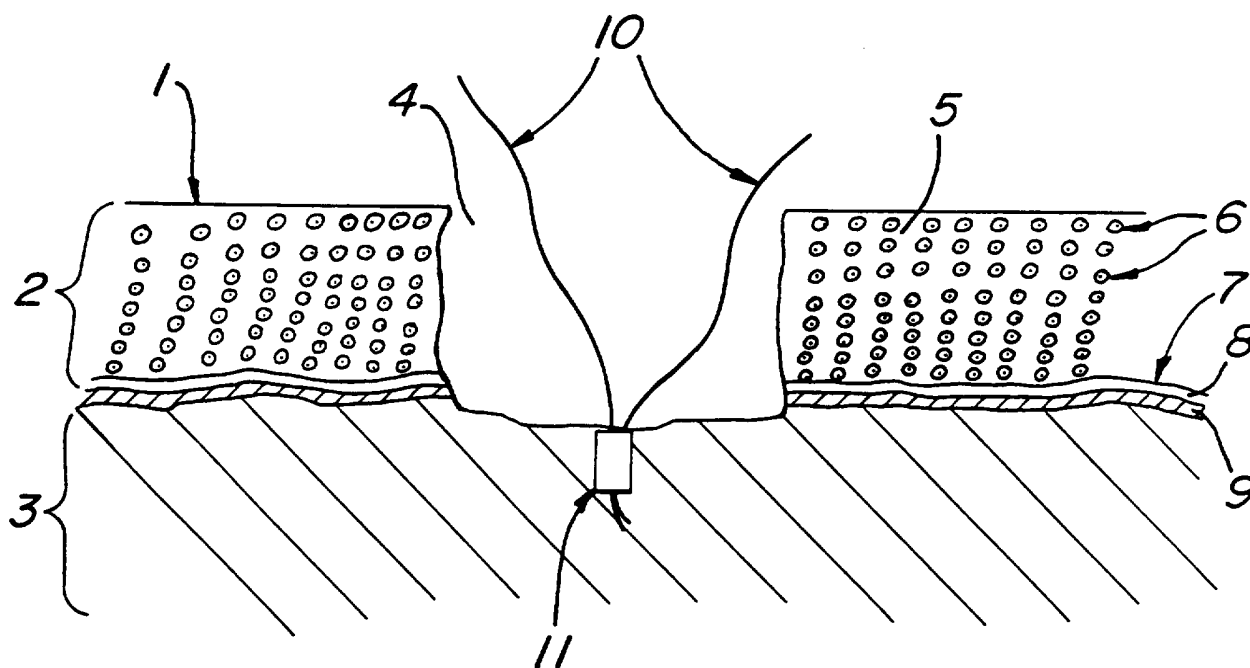

FIG. 3

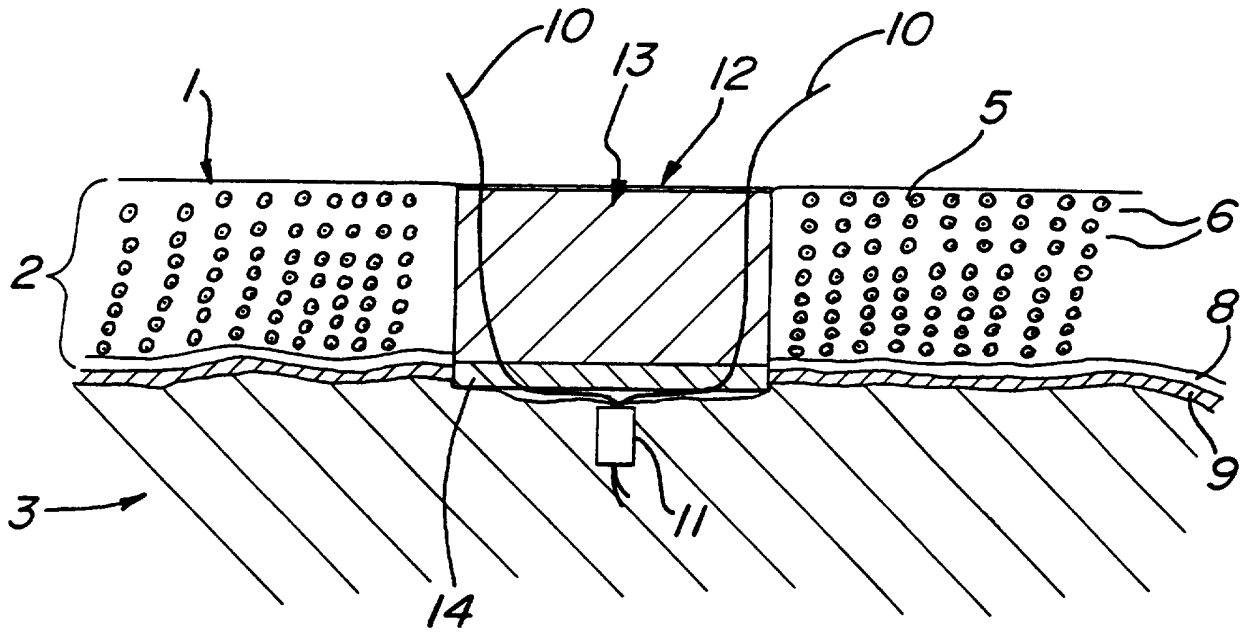
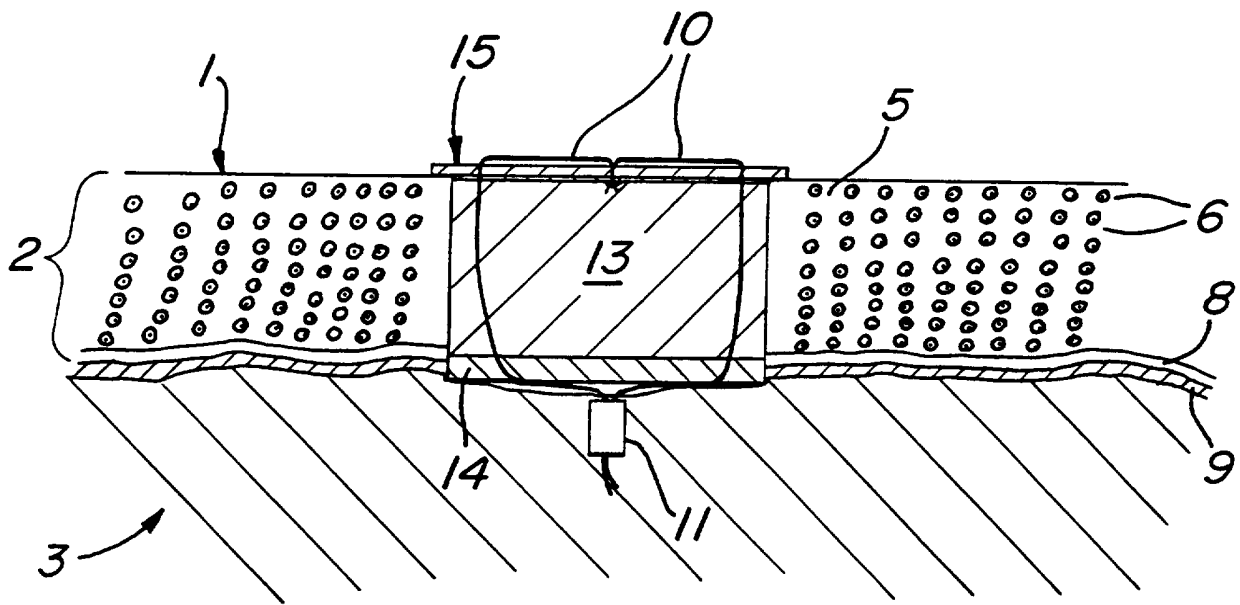

FIG. 4



INTERNATIONAL SEARCH REPORT

International application No.
PCT/US96-01742

A. CLASSIFICATION OF SUBJECT MATTER

IPC(6) : A61B 19/00
US CL : 128/898

According to International Patent Classification (IPC) or to both national classification and IPC

B. FIELDS SEARCHED

Minimum documentation searched (classification system followed by classification symbols)

U.S. : 128/897-898; 606/151.213.215.233; 602/042-043.053.079; 623/11.13.16.66

Documentation searched other than minimum documentation to the extent that such documents are included in the fields searched

Electronic data base consulted during the international search (name of data base and, where practicable, search terms used)

C. DOCUMENTS CONSIDERED TO BE RELEVANT

Category*	Citation of document, with indication, where appropriate, of the relevant passages	Relevant to claim No.
A	US, A, 5,053,050 (ITAY) 01 October 1991, see entire document.	1-11
A	US, A, 4,846,835 (GRANDE) 11 July 1989, see entire document.	1-11
A	US, A, 5,041,138 (VACANTI ET AL) 20 August 1991, see entire document.	1-11

Further documents are listed in the continuation of Box C. See patent family annex.

<p>* Special categories of cited documents:</p> <p>"A" Document defining the general state of the art which is not considered to be part of particular relevance</p> <p>"E" earlier document published on or after the international filing date</p> <p>"L" document which may throw doubts on priority claim(s) or which is cited to establish the publication date of another citation or other special reason (as specified)</p> <p>"O" document referring to an oral disclosure, use, exhibition or other means</p> <p>"P" document published prior to the international filing date but later than the priority date claimed</p>	<p>"T" later document published after the international filing date or priority date and not in conflict with the application but cited to understand the principle or theory underlying the invention</p> <p>"X" document of particular relevance: the claimed invention cannot be considered novel or cannot be considered to involve an inventive step when the document is taken alone</p> <p>"Y" document of particular relevance: the claimed invention cannot be considered to involve an inventive step when the document is combined with one or more other such documents, such combination being obvious to a person skilled in the art</p> <p>"&" document member of the same patent family</p>
---	---

Date of the actual completion of the international search
09 MAY 1996

Date of mailing of the international search report
23 MAY 1996

Name and mailing address of the ISA/US
Commissioner of Patents and Trademarks
Box PCT
Washington, D.C. 20231

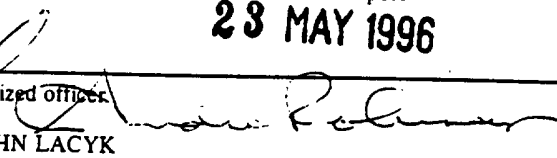
Authorized officer: 
JOHN LACYK

Facsimile No. (703) 305-3230

Telephone No. (703) 308-0858