

(12) **UK Patent Application** (19) **GB** (11) **2 300 145** (13) **A**

(43) Date of A Publication **30.10.1996**

(21) Application No **9606582.6**

(22) Date of Filing **28.03.1996**

(30) Priority Data

(31) **19513078** (32) **07.04.1995** (33) **DE**

(71) Applicant(s)

**Scintilla AG**

**(Incorporated in Switzerland)**

**Box 632, CH-4502, Solothurn, Switzerland**

(72) Inventor(s)

**Alfred Odendahl**

**Aldo Di Nicolantonio**

**Urs Ruepp**

(74) Agent and/or Address for Service

**A A Thornton & Co**

**Northumberland House, 303-306 High Holborn,  
LONDON, WC1V 7LE, United Kingdom**

(51) INT CL<sup>6</sup>

**B23D 49/16 , B27B 19/09**

(52) UK CL (Edition O )

**B5L LGB L104**

(56) Documents Cited

**GB 2077656 A**

**WO 91/12937 A**

(58) Field of Search

UK CL (Edition O ) **B5L LGA LGB LGX**

INT CL<sup>6</sup> **B23D , B27B**

(54) **Blade guides**

(57) In a compass saw having a saw blade (22), clamped in the lower region of a lifting rod (20) has supporting means which comprise a shaped roller (27) which laterally supportively embraces both the saw blade back (24) and the flat sides of the saw blade (22). Further support is provided by conical rollers (30, 31) engaging the sides of the blade (22).

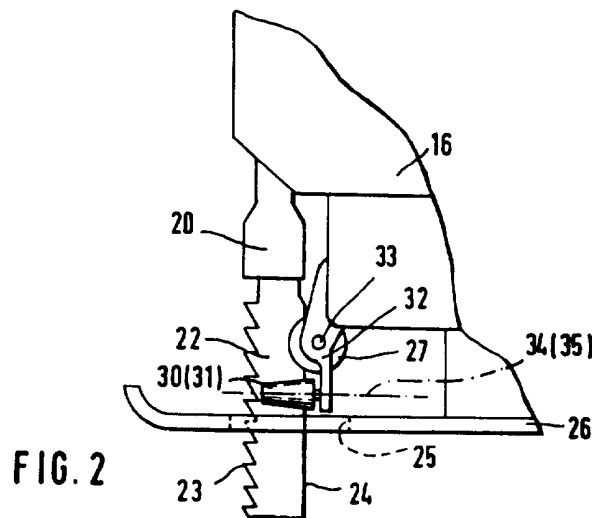

**FIG. 2**

**GB 2 300 145 A**

FIG. 1

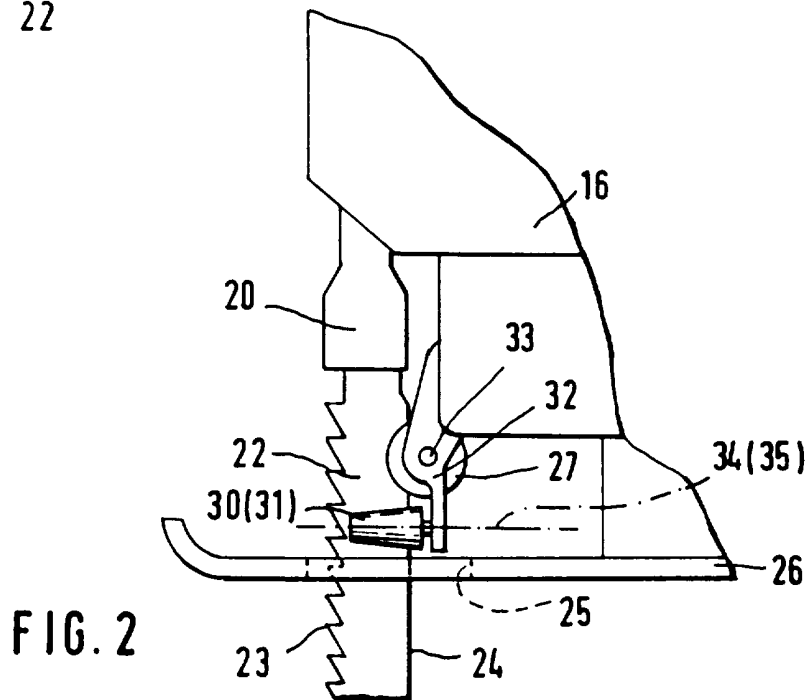
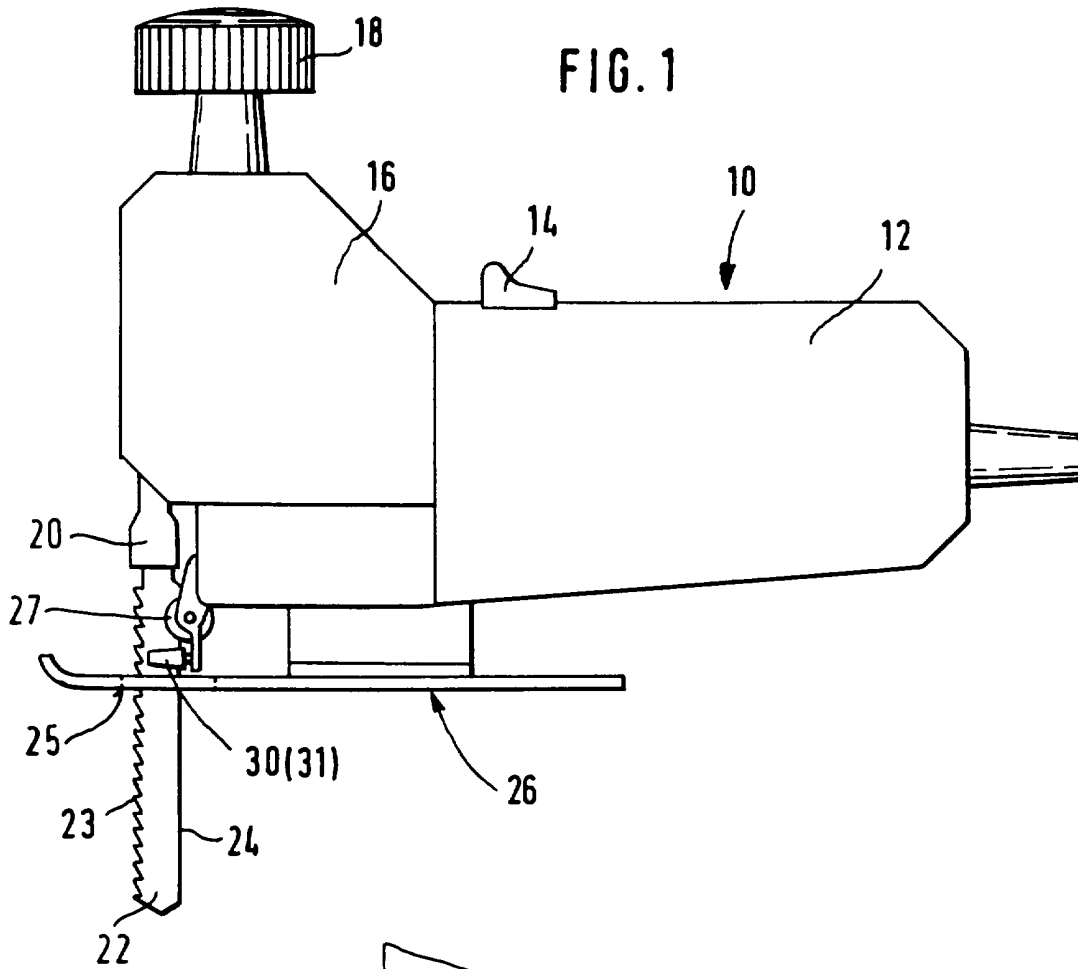

FIG. 2

FIG. 3

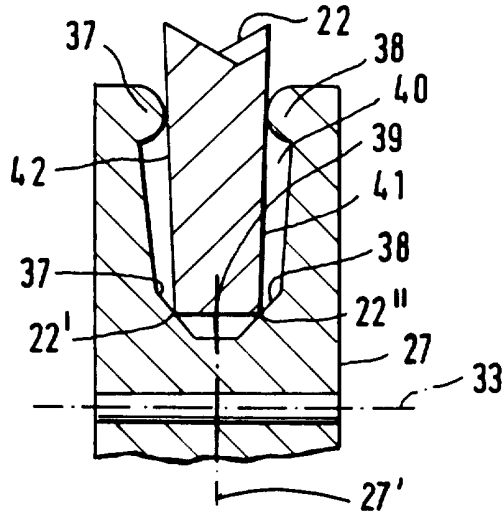

FIG. 4

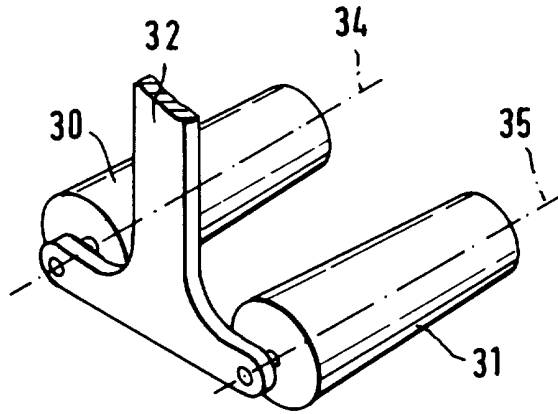
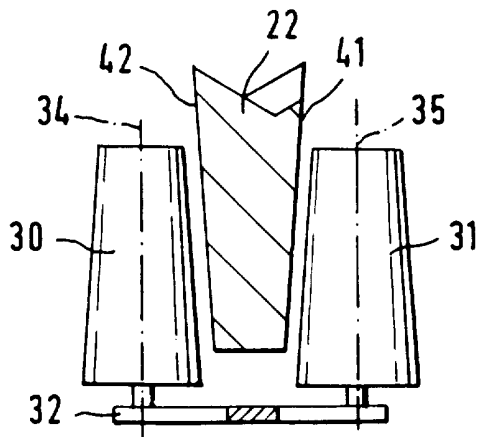

FIG. 5



Compass saw

Background art

The invention proceeds from a compass saw according to the preamble of claim 1.

From DE-OS 36 02 605, a compass saw is known, the saw blade of which is guided between two rollers which are parallel to its flat sides. By said means a lateral deflection or bending of the saw blade during sawing is to be prevented. During support, there is line contact between the rollers and the saw blade.

In other compass saws, it is known to guide and support the back of the saw blade above the base plate in the circumferential groove of a guide roller. By said means, the bottom lifting rod bearing and the clamping means for holding the saw blade are to be kept free of vibrations and bending forces during sawing.

Owing to the fact that the saw blade is supported by its back close to the base plate - and hence close to the engagement of the tool in the workpiece, the saw blade is bendable not over its full length between the tip of the saw blade and the clamped end but only between the tip of the saw blade and the guide roller. This increases the stiffness of the saw blade.

Hitherto, the rollers guiding the back of the saw blade have been provided with a V-shaped groove or with a flat U-shaped groove, the back of the saw blade being supported only by its two outer edges against the sides or inclined faces of the groove and therefore being relatively easily bendable at right angles to the feed direction and rotatable about its

longitudinal axis. Consequently, with the previous compass saws it is impossible to achieve the same high-quality results as are achievable, for example, with circular saws. Channels cut with conventional compass saws, in simple terms, follow a zigzag or S-shaped course.

Further compass saws have, disposed in the base plate at the through-slot for the saw blade, lateral sliding surfaces against which the saw blade in the event of a specific lateral deflection is laterally supported with a high degree of stability, the sliding friction causing a correspondingly high amount of wear of the saw blade and, in addition to the heating associated with the saw, high heat generation up to burn-out as well as reduced efficiency of the saw.

#### Advantages of the invention

In contrast, the compass saw according to the invention having the characterizing features of claim 1 has the advantage that the saw blade is guided much better than with the previously used rollers, i.e. with the same stability as with sliding surfaces but without their disadvantageous friction. As a result, with the compass saw according to the invention it is possible to achieve straight cuts of virtually the same quality as is achievable with a circular hand saw.

The service life of compass saw blades used in the compass saw according to the invention is markedly increased as a result of the reduced bending and torsion but above all as a result of the decrease in heat generation arising from friction reduction. Furthermore, because the cutting channel course is precisely rectilinear and hence narrower and shorter, the working capacity of the compass saw according to the invention is higher than that of previous compass saws.

Because of the precisely straight and hence narrower and shorter cutting channels, a smaller quantity of material is

removed and less energy is consumed, with the result that environmental pollution is reduced.

Further advantageous refinements of the invention are indicated in the dependent claims.

#### Drawings

There follows a detailed description of embodiments of the invention with reference to the accompanying drawings.

Of said drawings, Figure 1 is a side view of the compass saw according to the invention, Figure 2 a cutout of the compass saw according to Figure 1 in the region of the saw blade above the base plate, Figure 3 a cross section of the guide roller according to Figure 2, Figure 4 the three-dimensional view of the transverse supporting rollers according to Figure 2 and Figure 5 a plan view of the transverse supporting rollers with a saw blade guided between them.

#### Description of the embodiment

The compass saw 10 shown in Figure 1 comprises a motor housing 12, which serves as the main handle and carries an electric on-off switch 14.

The motor housing 12 is flange-mounted on a gearbox 16, which in its upper region carries an additional handle 18. Extending out of the lower region of the gearbox 16 is a lifting rod 20 carrying a saw blade 22, which has a serrated side 23 pointing in feed direction and a saw blade back 24 on the opposite side. The saw blade 22 passes through a slot 25 in a base plate 26.

Disposed above the base plate 26 close to the saw blade 22 is a shaped roller 27, into the shaped groove of which the saw blade back 24 dips. The latter is supported by its two rear

edges against the groove base of the shaped roller 27 and by its flat sides against the O-ring-like, circumferential inner beads of the guide roller 27 which are shown in Figure 3. Below the guide roller 27, close to the base plate 26, it is possible to see one of two adjacent, lateral, transverse supporting rollers 30, 31, which are described in detail with reference to Figures 2 and 3.

Figure 2 shows an enlarged cutout of the compass saw 10 according to Figure 1, in which the gearbox 16, the upper region of the saw blade 22, the shaped roller 27 and one of two lateral, truncated-cone-shaped transverse supporting rollers 30, 31 may be seen. The shaped roller 27 and the transverse supporting rollers 30, 31 are carried by a common bearing block 32, which is elastically bendable and therefore ensures a specific spring action between the supporting means 27, 10, 31 and the saw blade 22.

The axis 33 of the shaped roller 27 extends at right angles to the feed direction, the axes 34, 35 of the transverse supporting rollers 30 extend parallel to the feed direction.

Figure 3 shows the profile of the shaped roller 27, as a detail, together with the saw blade 22. It is evident both that the rear edges 22', 22" of the saw blade back 24 are guided supported against the two inclined faces 37, 38 of the base 39 of the groove 40 and that the side surfaces 41, 42 of the saw blade 22 are supported by axial annular surfaces 37, 38. Consequently, the forces which are effective during sawing cannot cause a deflection of the saw blade 22 at right angles to the feed direction.

Figure 4 shows a three-dimensional view of the two conical transverse supporting rollers 30, 31, which are disposed below the shaped roller 27, with the axes of rotation 34, 35 and the bearing block 32.

In Figure 5, the two truncated-cone-shaped transverse supporting rollers 30, 31 are shown disposed a slight distance away from the side surfaces 41, 42 of the saw blade 22 and extending parallel to said side surfaces.

Here, it is clearly demonstrated that the saw blade 22 in the event of lateral deflection may be applied against a respective one of the transverse supporting rollers 31, 32. Such an occurrence leads only to rolling friction with a correspondingly low loss of performance and low heat generation, a bending deflection of the saw blade 22 at right angles to the feed direction beyond the stop formed by a respective one of the transverse supporting rollers 31, 32 being effectively prevented.

In an embodiment of the invention which is not illustrated, the shaped roller comprises two shaped discs disposed in a mirror-inverted manner relative to one another and supported axially against one another symmetrically relative to the centre of the roller, the profile substantially taking the shape of an O-ring. Furthermore, the bearing block is elastically bendable in the oscillating direction of the saw blade to enable it to follow the oscillating motion of the saw blade.



## Claims

1. Compass saw (10), having a saw blade (22) which is held at the bottom end of a lifting rod (20), is guided against housing-fixed supporting means (27, 30, 31) and has a saw blade back (24) as well as flat sides (41, 42), characterized in that the supporting means (27, 30, 31) comprise an integral shaped roller (27), the profile of which supportively embraces the saw blade back (24) as well as the flat sides (41, 42) close to their centre.
2. Compass saw according to the preamble of claim 1, characterized in that the supporting means (27, 30, 31) comprise a shaped roller (27), the profile of which supportively embraces the saw blade back (24) as well as the flat sides (41, 42) close to their centre, the shaped roller (27) comprising two shaped discs disposed in a mirror-inverted manner relative to one another and axially supported against one another symmetrically relative to the roller centre (27').
3. Compass saw according to claim 1 or 2, characterized in that the opposing faces of the shaped roller (27) or of the shaped discs each carry, preferably integrally, at least one ring, which in particular is concentric relative to the axis (33) of the shaped roller (27) and preferably has a round cross section.
4. Compass saw according to the preamble of claim 1, characterized in that the supporting means (27, 41, 42) comprise at least one conical transverse supporting

roller (30, 31) which guides the conically extending flat sides (41, 42) of the saw blade (22).

5. Compass saw according to claims 1 to 4, characterized in that the shaped roller (27) together with the at least one transverse supporting roller (30, 31) disposed below the shaped roller (27) supports the saw blade.
6. Compass saw according to claim 5, characterized in that the axis (33) of the shaped roller (27) extends at right angles to the feed direction and the axis (34, 35) of the transverse supporting roller (30, 31) extends parallel to the feed direction.
7. Compass saw according to claim 6, characterized in that the transverse supporting roller (30, 31) is disposed below the shaped roller (27) close to the base plate (26).
8. Compass saw according to one of the preceding claims, characterized in that two transverse supporting rollers (30, 31) and the guide roller (27) are carried jointly by one bearing block (32).
9. Compass saw according to claim 8, characterized in that the bearing block (32) is elastically bendable in the oscillating direction of the saw blade (22).
10. A compass saw substantially as herein described with reference to the accompanying drawings.



Application No: GB 9606582.6  
Claims searched: 1-10

Examiner: Dave Butters  
Date of search: 24 July 1996

**Patents Act 1977**  
**Search Report under Section 17**

**Databases searched:**

UK Patent Office collections, including GB, EP, WO & US patent specifications, in:  
UK Cl (Ed.O): B5L  
Int Cl (Ed.6): B23D, B27B  
Other:

**Documents considered to be relevant:**

Category	Identity of document and relevant passage	Relevant to claims
X	GB 2077656 A ( METABOWERKE )	1
X	WO 91/12937 A ( HYLDIG )	2,3

X	Document indicating lack of novelty or inventive step	A	Document indicating technological background and/or state of the art.
Y	Document indicating lack of inventive step if combined with one or more other documents of same category.	P	Document published on or after the declared priority date but before the filing date of this invention.
&	Member of the same patent family	E	Patent document published on or after, but with priority date earlier than, the filing date of this application.