

APPLICATION FOR A STANDARD PATENT

I/We

Board of Regents, The University of Texas System

of

201 West Seventh Street, Austin, Texas, 78701, United States of America

hereby apply for the grant of a Standard Patent for an invention entitled:

Multiple material systems and assisted powder handling for selective beam sintering

which is described in the accompanying complete specification.

Details of basic application(s):-

<u>Number</u>	<u>Convention Country</u>	<u>Date</u>
402693	United States of America	5 September 1989
402694	United States of America	5 September 1989

The address for service is care of DAVIES & COLLISON, Patent Attorneys, of 1 Little Collins Street, Melbourne, in the State of Victoria, Commonwealth of Australia.

DATED this THIRTY FIRST day of AUGUST 1990

To: THE COMMISSIONER OF PATENTS

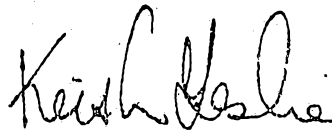

.....
a member of the firm of
DAVIES & COLLISON for
and on behalf of the
applicant(s)

Davies & Collison, Melbourne

M 020700 3/100012

AUSTRALIA

DTM005/4-1CIP2-3(B)

PATENTS ACT

DECLARATION FOR A PATENT APPLICATION

In support of the Convention application made by Board of Regents, The University of Texas System, an institution organized under the laws of the State of Texas, (hereinafter called Applicant) for a patent for an invention entitled "Multiple Material Systems and Assisted Powder Handling for Selective Beam Sintering" I, Hans Mark, Chancellor of The University of Texas System, do solemnly and sincerely declare as follows:

1. I am authorized to make this declaration on behalf of the Applicant.

2. Joseph J. Beaman
700 Texas Avenue
Austin, Texas 78705
USA

Carl R. Deckard
1801 Pin Oak Lane
Round Rock, Texas 78681
USA

David L. Bourell
5403 Wolf Run
Austin, Texas 78749
USA

Harris L. Marcus
4102 Hyridge
Austin, Texas 78759
USA

Joel W. Barlow
3101 Silverleaf Drive
Austin, Texas 78757
USA

are the actual inventors of the invention and the facts upon which the applicant is entitled to make the application are as follows:

Board of Regents, The University of Texas System, is the Assignee by Assignments from the inventors dated October 13, 1989, October 17, 1989, October 19, 1989, and October 24, 1989; and recorded on Reel 5187, Frames 050 and 051, and Reel 5189, Frames 872, 873, 874, 875, and 876 in the United States Patent and Trademark Office, in respect of the invention.

3. The basic applications for patent or similar protection on which the application is based is identified by country, filing date, and basic applicant as follows:

United States of America Application

Serial No. 402,693

Filed September 5, 1989 By Joseph J. Beaman and Carl R. Deckard

United States of America Application

Serial No. 402,694

Filed September 5, 1989 by Joseph J. Beaman; Carl R. Deckard; David L. Bourell; Harris L. Marcus and Joel W. Barlow

4. The basic applications referred to in paragraph 3 hereof were the first applications made in a Convention country in respect of the invention the subject of the application.

Declared at Austin, Texas this 13th day of October, 1990.

BOARD OF REGENTS,
THE UNIVERSITY OF TEXAS SYSTEM

By: Hans Mark
Typed Name: Hans Mark
Title: Chancellor

To: The Commission of Patents

Davies & Collison
Patent Attorneys
1 Little Collins Street
Melbourne, Victoria 3000
AUSTRALIA



(12) PATENT ABRIDGMENT (11) Document No. AU-B-62065/90
(19) AUSTRALIAN PATENT OFFICE (10) Acceptance No. 643700

(54) Title
MULTIPLE MATERIAL SYSTEMS AND ASSISTED POWDER HANDLING FOR SELECTIVE BEAM SINTERING

International Patent Classification(s)
(51)⁵ **B22F 003/10 B22F 007/02 B29C 067/04**

(21) Application No. : **62065/90** (22) Application Date : **31.08.90**

(30) Priority Data

(31) Number	(32) Date	(33) Country
402693	05.09.89	US UNITED STATES OF AMERICA
402694	05.09.89	US UNITED STATES OF AMERICA

(43) Publication Date : **14.03.91**

(44) Publication Date of Accepted Application : **25.11.93**

(71) Applicant(s)
THE UNIVERSITY OF TEXAS SYSTEM BOARD OF REGENTS

(72) Inventor(s)
DAVID L. BOURELL; HARRIS L. MARCUS; JOEL W. BARLOW; JOSEPH J. BEAMAN; CARL R. DECKARD

(74) Attorney or Agent
DAVIES COLLISON CAVE , 1 Little Collins Street, MELBOURNE VIC 3000

(56) Prior Art Documents
WO 88/02677
EP 221276
US 4247503

(57) Claim

1. An apparatus for producing a part comprising: beam means for selectively emitting a directed energy beam; structure for providing a target area for producing the part; means for depositing a powder into said target area; control means for moving the aim of the beam and for modulating the beam means to selectively sinter within defined boundaries a layer of powder deposited in said target area, the control means being operable to effect selective sintering of sequential layers of powder within respective defined boundaries to produce a part comprising a plurality of layers sintered together; and means for attaining a high bulk density in said powder in said target area.

15. A method of producing a part comprising the steps of:
depositing a powder comprising at least a first material and a second material onto a target surface as a powdery layer, said first material being a metal and having a lower softening temperature than said second material,
directing an energy beam at the target surface in such a manner that a selected portion of said powdery layer, corresponding to a cross-sectional region

of said part, is heated by the energy of said beam to a temperature so as to bond said second material therewith in said selected portion,

repeating said depositing and directing steps for a plurality of powdery layers so that bonded portions of said plurality of powdery layers bond to one another to form a mass in layerwise fashion,

removing unbonded portions of the powder to yield the mass.

18. A method of producing a part comprising the steps of: depositing powder onto a target surface; increasing the bulk density of said powder; and directing an energy beam at the target surface in such a manner that a selected portion of said powder corresponding to a cross-sectional region of the part is sintered by the energy of said beam.

31. A method of producing a part comprising the steps of:
depositing a powder onto a target surface, said powder comprising first and second materials;

directing an energy beam at the target surface in such a manner that a selected portion of said powder corresponding to a cross-sectional region of the part is heated by the energy of said beam to a sufficient temperature that said first material in said selected portion adheres particles of said second material into a mass thereat;

repeating said depositing and irradiating steps for a plurality of layers so that portions of the masses formed in adjacent layers bond to one another; and removing unbonded portions of the powder to yield the part; and heating the mass after said removing step.

643700

COMMONWEALTH OF AUSTRALIA
PATENTS ACT 1952
COMPLETE SPECIFICATION

NAME & ADDRESS
OF APPLICANT:

Board of Regents, The University of Texas System
201 West Seventh Street
Austin Texas 78701
United States of America

NAME(S) OF INVENTOR(S):

David L. BOURELL
Harris L. MARCUS
Joel W. BARLOW
Joseph J. BEAMAN
Carl R. DECKARD

ADDRESS FOR SERVICE:

DAVIES & COLLISON
Patent Attorneys
1 Little Collins Street, Melbourne, 3000.

COMPLETE SPECIFICATION FOR THE INVENTION ENTITLED:

Multiple material systems and assisted powder handling for selective beam sintering

The following statement is a full description of this invention, including the best method of performing it known to me/us:-

DESCRIPTION

5 Field of the Invention

 This invention relates to a method and apparatus which uses a directed energy beam to selectively sinter a powder to produce a part. In particular, this invention relates to a computer aided laser apparatus which sequentially sinters plural layers of powder to build the desired part in a layer-by-layer fashion. The present application is particularly directed towards a powder comprising plural powders in combination, each powder consisting of a material having a bonding temperature which may be the same or different from that of another material, and where a powder is dissociated, consisting of a material having a dissociation temperature which may be the same or different from that of another, and toward a device and method for dispensing a layer of powder to attain a high bulk density of the powder in each layer during sintering.

15 Description of the Relevant Art

 The economies associated with conventional part production methods are generally related directly to the quantity of parts to be produced and the desired material characteristics of the finished parts. For example, large scale manufacture casting and extrusion techniques are often cost effective, but these production methods are generally unacceptable for small quantities - i.e. replacement parts or prototype production. Many such conventional part

production methods require expensive part specific tooling. Even powder metallurgy requires a die for shaping the powder, making powder metallurgy unattractive as a method for producing a small number of parts.

Where only a small number of parts are desired, conventional production methods involving a subtractive machining method are usually used to produce the desired part. In such subtractive methods, material is cut away from a starting block of material to produce a more complex shape. Examples of subtractive machine tool methods include: milling, drilling, grinding, lathe cutting, flame cutting, electric discharge machine, etc. While such conventional machine tool subtractive methods are usually effective in producing the desired part, they are deficient in many respects.

First, such conventional machine tool subtractive methods produce a large amount of waste material for disposal. Further, such machine tool methods usually involve a large initial expense for setting up the proper machining protocol and tools. As such, the set-up time is not only expensive, but relies a great deal on human judgment and expertise. These problems are, of course, exacerbated when only a small number of parts are to be produced.

Another difficulty associated with such conventional machining techniques involves tool wear - which not only involves the cost of replacement, but also reduces machining accuracy as the tool wears. Another limit on the accuracy and tolerance of any part produced by conventional machining techniques is the tolerance limits inherent in the particular

machine tool. For example, in a conventional milling machine or lathe, the lead screws and ways are manufactured to a certain tolerance, which limits the tolerances obtainable in manufacturing a part on the machine tool. Of course, the tolerances attainable are reduced with age of the machine tool.

5
10
15
20
25
30
35

The final difficulty associated with such conventional machine tool subtractive processes is the difficulty or impossibility of making many part configurations. That is, conventional machining methods are usually best suited for producing symmetrical parts and parts where only the exterior part is machined. However, where a desired part is unusual in shape or has internal features, the machining becomes more difficult and quite often, the part must be divided into segments for production. In many cases, a particular part configuration is not possible because of the limitations imposed upon the tool placement on the part. Thus, the size and configuration of the cutting tool do not permit access of the tool to produce the desired configuration.

There are other machining processes which are additive, for example, plating, cladding, and some welding processes are additive in that material is added to a starting substrate. In recent years, other additive-type machining methods have been developed which use a laser beam to coat or deposit material on a starting article. Examples include U.S. Patent Nos. 4,117,302; 4,474,861; 4,300,474; and 4,323,756. These recent uses of lasers have been primarily limited to adding a coating to a previously machined article. Often such laser coating methods have been employed to achieve certain

metallurgic properties obtainable only by such coating methods. Typically, in such laser coating methods the starting article is rotated and the laser directed at a fixed location with the coating material sprayed onto the article so that the laser will melt the coating onto the article.

5 Additionally a process for compressing a powder based material into a coherent mass prior to sintering has been suggested. An example includes United States Patent No. 4,752,352.

SUMMARY OF THE INVENTION

10 The problems outlined above are in large measure solved by the method and apparatus of the present invention. The present invention includes a directed energy beam - such as a laser - and is adaptable to produce almost any three dimensional part.

15 The method of the present invention is not limited to a particular type of powder, but rather is adaptable to plastic, metal, polymer, ceramic, wax, semiconductor or amorphous powders, or composite material powders.

20 The method of the present invention is an additive process, with the powder being dispensed into a target area where the laser selectively sinters a portion of the powder to produce a sintered layer. In a first aspect, the invention includes increasing the bulk density of the powder. For example, the powder may be sintered at a temperature which causes viscous flow, for example, at contiguous boundaries of particles of the powder, with at least some portion of each particle remaining solid. Such sintering causes the density of the sintered portion to increase compared to the bulk density of that portion of powder before it was sintered, and a part formed by layer-wise joining of plural layers is therefore said to be autogenously densified. Thus, in this first aspect, the invention provides a method of producing
25 a part comprising the steps of: depositing powder onto a target surface; increasing the bulk density of said powder; and directing an energy beam at the target surface in such a manner that a selected portion of said powder corresponding to a cross-sectional region of the part is sintered by the energy of said beam.

30 In its first aspect, the invention also provides apparatus which includes a laser or other directed energy source which is selectable for emitting a beam in a target area where the part is produced. A powder dispenser system deposits powder into



the target area. A control mechanism operates to move the aim of the beam and modulates the beam means to selectively sinter a layer of powder dispensed into the target area. The control mechanism operates to selectively sinter only the powder disposed within defined boundaries to produce the desired layer of the part. The control mechanism operates to selectively sinter sequential layers of powder, producing a completed part comprising a plurality of layers sintered together. The defined boundaries of each layer correspond to respective cross-sectional regions of the part. Preferably, the control mechanism includes a computer - e.g. a CAD/CAM system - to determine the defined boundaries for each layer. That is, given the overall dimensions and configuration of the part, the computer determines the defined boundaries for each layer and operates the laser control mechanism in accordance with the defined boundaries. Alternatively, the computer can be initially programmed with the defined boundaries of each layer.

In a preferred form, the laser control mechanism includes a mechanism for directing the laser beam in the target area and a mechanism for modulating the laser beam on and off to selectively sinter the powder in the target area. In one embodiment, the directing mechanism operates to move the aim of the laser beam in a continuous raster scan of target area. The modulating mechanism turns the laser beam on and off so that the powder is sintered only when the aim of the laser beam is within the defined boundaries for the particular layer. Alternatively, the directing mechanism aims the laser beam only within the defined boundaries for the particular layer so that the laser beam can be left on continuously to sinter the powder within the defined boundaries for the particular layer.

In a preferred embodiment, the directing mechanism moves the laser beam in a repetitive raster scan of the target area using a pair of mirrors driven by galvanometers. The first mirror reflects the laser beam to the second mirror which reflects the beam into the target area. Shifting movement of the first mirror by its galvanometer shifts the laser beam generally in one direction in the target area. Similarly, shifting movement of the second mirror by its galvanometer shifts the laser beam in the target area in a second direction. Preferably, the mirrors are oriented relative to each other so that the first and second directions are generally perpendicular to each other. Such an arrangement allows for many different types



of scanning patterns of the laser beam in the target area, including the raster scan pattern of the preferred embodiment of the present invention.

In a second aspect, the invention provides a method of producing a part comprising the steps of:

5 depositing a powder comprising at least a first material and a second material onto a target surface as a powdery layer, said first material being a metal and having a lower softening temperature than said second material,

directing an energy beam at the target surface in such a manner that a selected portion of said powdery layer, corresponding to a cross-sectional region of
10 said part, is heated by the energy of said beam to a temperature so as to bond said second material therewith in said selected portion,

repeating said depositing and directing steps for a plurality of powdery layers so that bonded portions of said plurality of powdery layers bond to one another to form a mass in layerwise fashion,

15 removing unbonded portions of the powder to yield the mass.

The invention still further provides, in a third aspect a method of producing a part comprising the steps of:

depositing a powder onto a target surface, said powder comprising first
and second materials;

20 directing an energy beam at the target surface in such a manner that a selected portion of said powder corresponding to a cross-sectional region of the part is heated by the energy of said beam to a sufficient temperature that said first material in said selected portion adheres particles of said second material into a mass thereat;

25 repeating said depositing and irradiating steps for a plurality of layers so that portions of the masses formed in adjacent layers bond to one another; and removing unbonded portions of the powder to yield the part; and heating the mass after said removing step.

30 In an embodiment, a method of part production in accordance with the present invention includes the steps of depositing a first portion of powder onto a target surface, scanning the aim of a directed energy beam (preferably a laser) over the target surface, and sintering a first layer of the first powder portion on the target surface. The first layer corresponds to a first cross-sectional region of

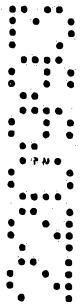

the part. The powder is sintered by operating the directed energy source when the aim of the beam is within the boundaries defining the first layers. A second portion of powder is deposited onto the first sintered layer and the aim of the laser beam scanned over the first sintered layer. A second layer of the second powdered portion is sintered by operating the directed energy source when the aim of the beam is within the boundaries defining the second layer. Sintering of the second layer also joins the first and second layers into a cohesive mass. Successive portions of powder are deposited onto the previously sintered layers, each layer being sintered in turn. In one embodiment, the powder is deposited continuously into the target.

In a preferred embodiment, the laser beam is modulated on and off during the raster scan so that the powder is sintered when the aim of the beam is directed within the boundaries of the particular layer. Preferably, the laser is controlled by a computer; the computer may include a CAD/CAM system, where the computer is given the overall dimensions and configuration of the part to be made and the computer determines the boundaries of each cross-sectional region of the part. Using the determined boundaries, the computer controls the sintering of each layer corresponding to the cross-sectional regions of the part. In an alternative embodiment, the computer is simply programmed with the boundaries of each cross-sectional region of the part.

Additionally, another embodiment of the present invention includes a powder comprising a plurality of materials where the plurality of materials have more than one dissociation

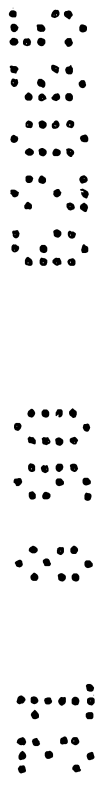

temperature. By dissociation temperature, it is meant that temperature at which a molecule breaks up into its parts. In still another embodiment of the present invention, the powder
5 comprises a plurality of materials where the plurality of materials have more than one bonding temperature. By bonding temperature, it is meant that temperature at which the powder is sintered, such temperature causing viscous flow
10 only at contiguous boundaries of particles with at least some portion of each particle remaining solid.

In certain of the preferred embodiments of the present invention, a powder comprising
15 plural materials in combination, one with another, includes (i) a blend of a first material intermixed with a second material, and optionally intermixed with a third and additional materials; and, (ii) a first material
20 coated with a second material, and optionally coated with a third and additional materials. When blended, a first powder may be deposited on a target surface, sintered, then followed by depositing and sintering a second powder, thus
25 bonding one layer to the next succeeding layer. If desired, additional materials may be added and sintered, sequentially, one layer at a time.

Additionally, another embodiment of the present invention includes an apparatus for
30 producing a part comprising a beam device for selectively emitting a directed energy beam, structure for providing a target area for producing the part, a device for depositing a powder into the target area, and a control
35 device for moving the aim of the beam and for modulating the beam to selectively sinter, within defined boundaries, a layer of powder

deposited in the target area. The control device is operable to effect selective sintering of sequential layers of powder within respective defined boundaries to produce a part comprising a plurality of layers sintered together. Preferably, the powder attains a high bulk density during sintering.

5
10
15
20
25
30
35

In an additional embodiment, the powder depositing device comprises apparatus to electrostatically charge and dispense the powder. Preferably, an electromagnetic field is produced proximate the target area wherein the field induces high bulk density in the powder in the target area during sintering.

As used throughout this document, electromagnetic field includes but is not limited to electrostatic and magnetostatic fields.

In still another embodiment of the present invention, the powder depositing device comprises apparatus to dispense a polarizable powder. Preferably, an electromagnetic field is produced proximate the target area where the field induces high bulk density by polarization forces in the powder in the target area during sintering.

In another embodiment of the present invention, the depositing device comprises apparatus to dispense the powder, with the powder having a first electrical charge and the target area having a second electrical charge. The first electrical charge is of opposite charge to the second electrical charge and the first charge may be of a different magnitude than the second charge.

In a further embodiment of the present invention, the depositing device comprises

apparatus to dispense a first portion of the powder on which there is a first electrical charge. The first portion of powder is flowed past a contouring device sufficiently close to the powder to remove its charge before the powder is deposited on the target area. Preferably, the depositing device further comprises apparatus to dispense a second portion of the powder with a second electrical charge on the second portion. The second electrical charge is opposite to the first electrical charge; the first charge may be of a different magnitude than the second charge.

In yet another embodiment of the present invention, the depositing device comprises an apparatus for directing a fluid stream to the powder deposited in the target area to increase the bulk density of the deposited powder during sintering.

In another embodiment of the present invention, the depositing device comprises an apparatus to enable the application of centrifugal force to the deposited powder to induce high bulk density in the powder.

The electromagnetic fields produced in the embodiments of the present invention may have varying field strengths across the target area.

In yet another embodiment of the present invention, the apparatus for depositing the powder further comprises an electrically charged drum, a device for moving the drum from one end of a region having a mound of powder to another end of the region with a desired spacing between the region and the drum, a device for rotating the drum counter to the direction of movement of the drum from one end of the region to the other, and the drum device being operable when

counter-rotated and moved from one end of the region to the other to contact the mound of powder and eject powder in the direction of movement to leave a layer of powder between the drum and the one end of the region. The layer of powder has a thickness of approximately the desired spacing.

In still another embodiment of the present invention, the powder is magnetic and the device for depositing the powder preferably comprises a device for producing an electromagnetic field proximate the target area where the electromagnetic field induces high bulk density in the powder in the target area during sintering.

An embodiment of a method of producing a part according to the present invention comprises the steps of depositing a first portion of powder onto a target surface, scanning the aim of a directed energy beam over the target surface, sintering a first layer of the first powder portion corresponding to a first cross-sectional region of the part by operating the beam when the aim of the beam is within boundaries defined by the first cross-sectional region, depositing a second portion of powder onto the first sintered layer, scanning the aim of a directed energy beam over the first sintered layer, sintering a second layer of a second powder portion corresponding to a second cross-sectional region of the part by operating the beam when the aim of the beam is within boundaries defined by the second cross-sectional region, and, during the sintering of the second layer, joining the first and second layers. Successive layers of powder are deposited onto the previous sintered layers and sintering of

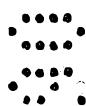

each successive portion is performed to produce a part comprising a plurality of sintered layers. Preferably, the steps of depositing the powder each further comprise the substep of
5 inducing and attaining a high bulk density in the first and second portions of powder during sintering.

In another embodiment of the method of the present invention, each depositing step further
10 comprises the substeps of electrostatically charging and dispensing the powder. Preferably, an electromagnetic field is produced proximate the target surface and the electromagnetic field induces high bulk density in the deposited
15 powder during sintering.

In another embodiment of the method of the present invention, a polarizable powder is dispensed. Preferably, an electromagnetic field is produced proximate the target area where the
20 electromagnetic field induces high bulk density by polarization forces in the deposited powder during sintering.

In yet another embodiment of the method of the present invention, each step of depositing
25 further comprises the substeps of dispensing the powder with the powder having a first electrical charge, and placing a second electrical charge on the target surface. The first electrical charge is of opposite charge to the second
30 electrical charge and the first charge may be of a different magnitude than the second charge.

In still another embodiment of the method of the present invention, each step of depositing
35 further comprises the substep of directing a fluid stream to said deposited powder to induce high bulk density in the deposited powder during sintering.

In yet another embodiment of the method of the present invention, each step of depositing further comprises the substep of applying centrifugal force to said deposited powder to induce high bulk density in the deposited powder so as to predensify the powder before it is sintered.

In still another embodiment of the method of the present invention, each step of depositing further comprises the substeps of placing a first electrical charge on a first portion of the powder, dispensing the first portion, and passing a contouring device proximal the dispensed first portion. Further, a second electrical charge is preferably placed on the second portion of the powder and the second portion is dispensed. The first electrical charge is preferably of opposite charge to the second electrical charge and the first charge may be of a different magnitude than the second charge.

In another embodiment of the method of the present invention, the powder is magnetic, e.g., ferromagnetic or other magnetizable material, and the depositing steps each further comprise the substep of producing an electromagnetic field proximate the target surface where the electromagnetic field induces high bulk density in the deposited powder during sintering.

A further embodiment of the present invention offers a method of applying a layer of powder in a region comprising the steps of depositing a mound of powder proximate one end of the region, moving an electrically charged drum in a direction from one end of the region towards another end of the region, rotating the drum counter to the direction of movement from the

one end towards the other end of the region, contacting the mound of powder with the counter-rotating drum as it moves towards the other end, and dispensing powder from under the drum in the direction of the drum's movement so as to leave a layer of powder behind the drum.

As can be appreciated from the above general description, the method and apparatus of the present invention solves many of the problems associated with known part production methods. First, the present invention is well suited for prototype part production or replacement part production of limited quantities. Further, the method and apparatus hereof are capable of making parts of complex configurations unobtainable by conventional production methods. Further, the present invention eliminates tool wear and machine design as limiting factors on the tolerances obtainable in producing the part. Finally, with the apparatus of the present invention incorporated into a CAD/CAM environment, a large number of replacement parts can be programmed into the computer and can be easily produced with little set-up or human intervention.

BRIEF DESCRIPTION OF THE DRAWINGS

FIGURE 1 is a schematic representation of the apparatus of the present invention;

FIGURE 2 is a schematic showing a portion of the layered build up of a part produced in accordance with the present invention, and illustrating the raster scan pattern of the laser beam in the target area;

FIGURE 3 is a block diagram depicting the interface hardware between the computer, laser and galvanometers of the present invention;

FIGURE 4 is a perspective view of an example part produced in accordance with the present invention;

5 FIGURE 5 is a sectional view with parts broken away and in phantom, of the part illustrated in FIGURE 4;

FIGURE 6 is a flow chart of the data metering program in accordance with the present invention;

10 FIGURE 7 is a sectional view taken along line 7-7 of FIGURE 4;

FIGURE 8 illustrates in diagram form the correlation between a single sweep of the laser across the layer of FIGURE 7 and the control signals of the present invention;

15 FIGURE 9 illustrates a blend of materials in a powder;

FIGURE 10 illustrates materials coated, one by the other, in a powder;

20 FIGURE 11 illustrates a portion of a sintering cycle on a blend of materials as presently understood.

FIGURE 12 illustrates two materials intermixed as sequential layers deposited prior to sintering.

25

FIGURE 13 is a schematic, vertical, sectional view of the powder dispensing device of the present invention distributing powder in a layer on the part being produced;

30 FIGURE 14 is a schematic, perspective view of the powder dispensing device of the present invention;

FIGURE 15 illustrates electric and magnetic fields interacting with a powder in accordance with the present invention;

35

FIGURE 16 illustrates a charged support plate and an oppositely charged layer of powder in accordance with the present invention;

5 FIGURES 17 and 18 illustrate pressurized fluid interacting with deposited powder of the present invention;

FIGURE 19 illustrates a magnetic field interacting with deposited powder of the present invention; and

10 FIGURE 20 illustrates an electric field interacting with a powder of the present invention.

DESCRIPTION OF THE PREFERRED EMBODIMENTS

Turning now to the drawings, FIGURE 1 broadly illustrates the apparatus 10 in accordance with the present invention. Broadly speaking, the apparatus 10 includes a laser 12, powder dispenser 14, and laser control means 16. In more detail, the powder dispenser 14 includes a hopper 20 for receiving the powder 22 and having an outlet 24. The outlet 24 is oriented for dispensing a combination of materials in powder form to a target area 26, which in FIGURE 1 is generally defined by the confinement structure 28. Of course, many alternatives exist for dispensing the powder 22.

The components of the laser 12 are shown somewhat schematically in FIGURE 1 and include a laser head 30, a safety shutter 32, and a front mirror assembly 34. The type of laser used is dependent upon many factors, and in particular upon the type of powder 22 that is to be sintered. In the embodiment of FIGURE 1, a Nd:YAG laser (Lasermetrics 9500Q) was used which can operate in a continuous or pulsed mode with a hundred-watt maximum outlet power in the continuous mode. The laser beam output of the

laser 12 has a wavelength of approximately 1060 nm, which is near infrared. The laser 12 illustrated in FIGURE 1 includes an internal pulse rate generator with a selectable range of about one kiloHertz to forty kiloHertz, and an approximately six nanosecond pulse duration. In either the pulsed or continuous mode, the laser 12 can be modulated on or off to selectively produce a laser beam which travels generally along the path shown by the arrows in FIGURE 1.

To focus the laser beam, a diverging lens 36 and converging lens 38 are disposed along the path of travel of the laser beam as shown in FIGURE 1. Using just the converging lens 38, the location of the true focal point is not easily controlled by varying the distance between the converging lens 38 and the laser 12. The diverging lens 36 placed between the laser 12 and converging lens 38 creates a virtual focal point between the diverging lens 36 and the laser 12. Varying the distance between the converging lens 38 and the virtual focal point, allows control of the true focal point along the laser beam path of travel on the side of the converging lens 38 remote from the laser 12. In recent years there have been many advances in the field of optics, and it is recognized that many alternatives are available to efficiently focus the laser beam at a known location.

In more detail, the laser control means 16 includes computer 40 and scanning system 42. In a preferred embodiment, the computer 40 includes a microprocessor for controlling the laser 12 and a CAD/CAM system for generating the data. In the embodiment illustrated in FIGURE 1, a personal computer is used (Commodore 64) whose primary attributes include an accessible

interface port and a flag line which generates a nonmaskable interrupt.

As shown in FIGURE 1, the scanning system 42 includes a prism 44 for redirecting the path of travel of the laser beam. Of course, physical layout of the apparatus 10 is the primary consideration in determining whether a prism 44, or a plurality of prisms 44, are needed to manipulate the path of travel of the laser beam. The scanning system 42 also includes a pair of mirrors 46, 47 driven by respective galvanometers 48, 49. The galvanometers 48, 49 coupled to their respective mirrors 46, 47 to selectively orientate the mirrors 46, 47. The galvanometers 46, 47 are mounted perpendicular to each other such that the mirrors 46, 47 are mounted nominally at a right angle to each other. A function generator driver 50 controls the movement of the galvanometer 48 (galvanometer 49 is slaved to the movement of galvanometer 48) so that the aim of the laser beam (represented by the arrows in FIGURE 1) can be controlled in the target area 26. The driver 50 is operatively coupled to the computer 40 as shown in FIGURE 1. It will be appreciated that alternative scanning methods are available for use as the scanning system 42, including acousto-optic scanners, rotating polygon mirrors, and resonant mirror scanners.

Turning to FIGURE 2 of the drawing, a portion of a part 52 is schematically illustrated and shows four layers 54-57. The aim of the laser beam, labeled 64 in FIGURE 2, is directed in a raster scan pattern as at 66. As used herein, "aim" is used in its ordinary sense indicating direction, but does not imply the modulation state of the laser 12. For convenience, the

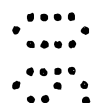

axis 68 is considered the fast scan axis, while the axis 70 is referred to as the slow scan axis. Axis 72 is the direction of part buildup.

5 FIGURES 9 and 10 schematically illustrate a powder comprising first and second materials from which a part may be made using the present invention.

10 FIGURE 9 illustrates a blend of first material 901 and second material 902. The materials are combined in a blend through conventional blending processes. FIGURE 10 illustrates material 1002 coated with material 1001. Material 1002 is coated using
15 conventional coating processes.

As will be further apparent to one skilled in the art, coated materials, as shown in FIGURE 10, may be blended to produce a desired mix of materials.

20 Turning to FIGURE 11, a portion of a sintering cycle, as presently understood, is illustrated. FIGURE 11a illustrates a blend of materials prior to the application of energy able to produce sintering. Preferably, the
25 materials comprising powder mass 1100 have more than one bonding or dissociation temperature. FIGURE 11b illustrates powder 1100 during application of energy sufficient to promote sintering. FIGURE 11b illustrates material 1101
30 having a lower bonding or dissociation temperature than material 1102. In a preferred embodiment, the low temperature phase material 1101 infiltrates powder mass 1100 in the area surrounding each particle of material 1101. In
35 a powder mixture of polymers of different materials, such infiltration is evidenced by chain diffusion and entanglement of chains of

one polymer with those of the other. In a mixture of first and second metals, present as a mass of porous powder of predetermined porosity, such infiltration is evidenced by interdiffusion of one metal into the surface of the other. Additional powder components could also be added to the blend to promote infiltration. Similarly a gas phase can be used to promote infiltration and the sintering process. The gas phase may be either inert or active, preferably to either displace an undesired gas or introduce a desired gas. FIGURE 11c illustrates a potential mechanism through which effects, including but not limited to, capillarity effects, allow material 1101 to infiltrate the powder mass 1100. FIGURE 11d shows the part following sintering in the present invention.

Because a material having a bonding or dissociation temperature higher than the temperature to be obtained during the sintering process may be selected, the higher bonding or dissociation temperature material need not sinter but may retain its original structure. In particular, for crystalline material this enables control of epitaxial growth in the selective beam sintering process of the present invention. For example, if the higher bonding or dissociation temperature material is positioned in a particular structure that may, preferably, result in epitaxial growth from the preceding layer, only bonding or dissociating the lower bonding or dissociation temperature material enables the higher temperature material to retain its structure.

The choice of materials selected for the powder allows for a broad range of resulting

sintered material. For example, a conducting material is preferably coated with an insulating polymer material to produce a powder. The powder is then distributed in the target area. 5 The material is preferably sintered and the insulator may be removed later through a conventional process, including but not limited to a chemical method, resulting in a conductive, sintered product.

10 By way of further illustration, extremely hard materials may be produced using the present invention. For example, tungsten carbide/cobalt tools which, because of their extreme hardness are difficult to form or sharpen may be produced by coating tungsten carbide material with cobalt 15 to produce a powder or by blending tungsten carbide and cobalt to produce a powder. During sintering, the cobalt preferably melts under the applied energy beam causing local infiltration of the tungsten carbide. 20 The part that is manufactured is ready to be put into service preferably after a secondary process including, but not limited to, annealing.

25 By way of further illustration, copper and tin may be combined in a powder. Tin, having a lower melting temperature than copper, will melt and infiltrate the copper during sintering.

30 Secondary processing may also be applied to parts produced using the present invention. For example, where tin is allowed to melt and infiltrate copper during sintering, post process annealing will dissolve the tin into the copper in the solid state creating bronze with minimal volume change or distortion.

35 By way of further illustration, metal, including but not limited to, iron or steel, may be coated with poly(methyl methacrylate) (PMMA)

polymer to form a powder. Sintering enables the PMMA to flow and bind the metal. Post process annealing will dissociate the PMMA and sinter the metal thus producing a final part.

5 Ceramic materials may be processed in this fashion as well. For example, a mixture of fluorophosphate glass powders with alumina powders will result in the glass softening and infiltrating the alumina during the sintering
10 process. In another example, aluminum silicate, silica, or other ceramic powder can be coated with a polymer by a variety of methods, including spray drying and solvent coating. A surface active agent may be used to pretreat the ceramic powder prior to coating. This agent may
15 be based on organosilane chemistry or other chemistries known to promote the wettability of the ceramic by the polymer and the adhesion of ceramic to polymer. Any polymer, either thermoplastic or thermoset, which can be coated
20 on the ceramic, can be used as a binder. Typical materials include PMMA, polystyrene, various epoxy formulations, and phenolics.

Any combination of materials, including but not limited to, metals, ceramics and polymers enables production of parts in accordance with the present invention wherein at least one material in the powder has a low bonding or dissociation temperature relative to the other materials in the powder.
25
30

In another preferred embodiment of the present invention, the temperature of the powder mass may be increased using conventional heating means allowing the energy beam to merely supply
35 a small increase of energy to produce bonding or dissociation of one of the elemental materials of the powder.

Materials comprising the powder may be chosen for each material's selective absorption of energy from a laser beam (represented by the arrows in FIGURES 11a and 11b). In the preferred embodiment shown in FIGURE 11, material 1101 may be chosen to absorb the wavelength of the applied beam energy represented by the arrows while elemental material 1102 absorbs less energy thereby enabling elemental material 1101 to bond or dissociate prior to the bonding or dissociation of elemental material 1102. This absorption of energy can be achieved by either material or laser beam wavelength selection, or both, in a plurality of combinations.

Turning to FIGURE 12, in yet another preferred embodiment a material 1201 is preferably deposited on surface 1200 and second material 1203 is then deposited on material 1201 prior to sintering. Materials 1201 and 1203 preferably have different bonding or dissociation temperatures.

Turning to FIGURES 13 and 14, an alternative form of powder dispenser 20 is illustrated. Broadly speaking, a support defines a target area 102 which is preferably electrically charged and where the aim of the beam 64 is directed (see FIG. 1). A hopper 104 dispenses the powder 106 through opening 108 into the target area 102. A metering roller (not shown) is disposed in the opening 108, such that when rotated the metering roller deposits a metered mound of powder in a line at end 110 of the target area 102.

A leveling mechanism 114 spreads the mound of powder 106 from end 110 to the other end 112 of the target area. The leveling mechanism 114

includes a cylindrical drum 116 having an electrical charge of opposite polarity to said target area 102. It is believed that the attractive forces between the charged layer of the powder 164 and the oppositely charged target area 102 create pressure on the powder layer 164 producing a high bulk density of powder 106 including powder in layer 164. A motor 118 mounted on bar 120 is coupled to the drum 116 via pulley 122 and belt 124 to rotate the drum.

The leveling mechanism 114 also includes a mechanism 126 for moving the drum 116 between end 110 and end 112 of the target area. The mechanism 126 comprises an X/Y table for moving the bar 120 horizontally and vertically. That is, table 128 is fixed while plate 130 is selectively moveable relative to table 128.

In the preferred embodiments of the present invention, the high bulk density of the deposited powder is preferably attained through the application of force on the deposited powder during sintering.

High bulk density in a powder may be obtained by simply applying a mechanical press to the powder during sintering where the press is preferably both transparent to the laser beam and has high thermal conductivity.

FIGURE 15 illustrates a preferred embodiment for attaining high bulk density in powder 1207 deposited on support plate 1201 in the target area. Powder 1207 is preferably electrically conductive. Positively charged plate 1209 and negatively charged plate 1211 are preferably positioned substantially perpendicular to support plate 1201 and in parallel and spaced relation to each other. Powder 1207 is positioned between plates 1209 and 1211 on

support plate 1201. An electric field 1203 is generated between positively charged plate 1209 and negatively charged plate 1211 through powder 1207. Magnetic field 1205 is also generated. The current flow due to field 1203 in combination with field 1205 creates a downward pressure 1213 on powder 1207 enabling powder 1207 to attain a higher bulk density than it would have had in the absence of the fields. Fields 1203 and 1205 may be maintained during sintering thus attaining a force on powder 1207 and attaining powder 1207 in high bulk density during sintering.

FIGURE 16 illustrates powder 1303, which is preferably insulative, positioned on charged support plate 1301. A charged layer of powder 1305 is preferably positioned as the top layer of powder 1303 and is preferably charged opposite that of the charge on support plate 1301. In a preferred embodiment, a charged counter-rotating drum (as shown in FIGURE 13) may be used to charge layer 1305. Attraction between the opposite charges in support plate 1301 and layer of powder 1305 attain high bulk density in powder 1303.

Turning now to FIGURES 17 and 18, two preferred embodiments utilizing a pressurized fluid stream are illustrated. In FIGURE 17, powder 1401 is positioned on mesh restraint 1405 which also serves as a support plate for the dispensed powder in the target area. Fluid stream 1403 is applied from above mesh restraint 1405 as shown in FIGURE 17 enabling powder 1401 to attain a high bulk density. Mesh restraint 1405 preferably comprises material enabling fluid stream 1403 to pass but restraining powder 1401. FIGURE 18 illustrates another preferred

embodiment utilizing a fluid stream to attain a high bulk density in a powder. In FIGURE 18, powder 1501 is positioned on support plate 1507 and a pressurized fluid stream 1503 is applied from above support plate 1507 and powder 1501 as shown in FIGURE 18. Mesh restraints 1505 are positioned substantially perpendicular to support plate 1507 in spaced relation with powder 1501 deposited between mesh restraints 1505. The embodiment shown in FIGURE 18 enables a reduction in the buildup of excessive pressure on powder 1501 proximate support plate 1507 by allowing fluid stream 1503 to exit powder 1501 through mesh restraints 1505.

Turning now to FIGURE 19, magnetic powder 1603, which is preferably either magnetizable or hard ferromagnetic material, is positioned on support plate 1601. Magnetic field 1605 is preferably applied causing powder 1603 to form or attain a high bulk density.

Turning now to FIGURE 20, powder 1703 comprises polarizable elements 1705. For clarity, polarizable elements 1705 are only illustrated in distal relation to support plate 1701. However, elements 1705 may appear throughout powder 1703. Electric field 1707 is preferably generated through a charge appearing at support plate 1701. Field 1707 generates a downward force on elements 1705 producing a high bulk density in powder 1703.

FIGURES 15 through 20 illustrate preferred embodiments wherein a plurality of layers of sintered powder located proximal a support plate with a single layer of unsintered powder located distal the support plate. External force is, therefore, only required to attain high bulk density in the upper layer.

Operation

5 A fundamental concept of the present invention is the build up of a part in a layer-by-layer manner. That is, a part is considered a plurality of discrete cross-sectional regions which cumulatively comprise the three-dimensional configuration of the part. Each discrete cross-sectional region has defined two-dimensional boundaries - of course, each region
10 may have unique boundaries.

In the method, a first portion of powder 22 is deposited in the target area 26 and selectively sintered by the laser beam 64 to produce a first sintered layer 54 (FIGURE 2).
15 The first sintered layer 54 corresponds to a first cross-sectional region of the desired part. The laser beam selectively sinters only the deposited powder 22 within the confines of the defined boundaries.

20 There are, of course, alternative methods of selectively sintering the powder 22. One method is for the aim of the beam to be directed in a "vector" fashion - that is, the beam would actually trace the outline and interior of each cross-sectional region of the desired part. Alternatively, the aim of the beam 64 is scanned in a repetitive pattern and the laser 12 modulated. In FIGURE 2, a raster scan pattern
25 66 is used and is advantageous over the vector mode primarily in its simplicity of implementation. Another possibility is to combine the vector and raster scan methods so that the desired boundaries of the layer are traced in a vector mode and the interior
30 irradiated in a raster scan mode. There are, of course, trade-offs associated with the method chosen. For example, the raster mode has a

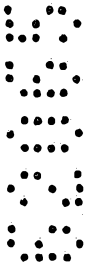

disadvantage when compared to the vector mode in that arcs and lines which are not parallel to the axes 68, 70 of the raster pattern 66 of the laser beam 64 are only approximated. Thus, in some cases resolution of the part can be degraded when produced in the raster pattern mode. However, the raster mode is advantageous over the vector mode in the simplicity of implementation.

5
10
15
20
Turning to FIGURE 1, the aim of the laser beam 64 is scanned in the target area 26 in a continuous raster pattern. Broadly speaking, the driver 50 controls galvanometers 48, 49 to made the raster pattern 66 (see FIGURE 2). Shifting movement of the mirror 46 controls movement of the aim of the laser beam 64 in the fast scan axis 68 (FIGURE 2), while movement of the mirror 47 controls movement of the aim of the laser beam 64 in the slow scan access 70.

25
30
35
The present position of the aim of the beam 64 is fed back through the driver 50 to the computer 40 (see FIGURE 3). As described below, in more detail, the computer 40 possesses information relating to the desired cross-sectional region of the part then being produced. That is, a portion of loose powder 22 is dispensed into the target area 26 and the aim of the laser beam 64 moved in its continuous raster pattern. The computer 40 modulates the laser 12 to selectively produce a laser beam at desired intervals in the raster pattern 66. In this fashion, the directed beam of the laser 12 selectively sinters the powder 22 in the target area 26 to produce the desired sintered layer with the defined boundaries of the desired cross-sectional region. This process is repeated layer-by-layer with the individual

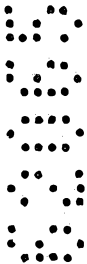

layers sintered together to produce a cohesive part - e.g. part 52 of FIGURE 2.

5 In operation, the wavelength of laser 12 may be varied to produce higher absorptivity of energy by selected materials in the powder relative to other materials in powder 22. In operation, blended, coated or other combinations of powders are preferably selected to produce
10 sintered product with characteristics including but not limited to, close dimensional tolerances, structural integrity and required mechanical behavior.

Turning now to FIGURES 13 and 14, the dispensing mechanism 114 has been found to provide a controlled level layer of powder in the target area 102 without disturbing the part being produced. A metered amount of powder 106 is deposited at end 110 of the target area 102. The electrically charged drum 116 is spaced away from end 110 when the powder 106 is dispensed. In the system illustrated in FIGURE 14, the plate 130 and bar 120 (and attached mechanisms) are raised vertically after the powder is dispensed in the mound. Travel of the plate 130
15 towards the hopper 104 brings the drum 116 into position adjacent the mound of powder lined up along end 110. The drum 116 is lowered to contact the mound of powder and brought horizontally across the target area 102 to spread the mound of powder in a smooth even layer. Of course, the precise location of plate 130 relative to table 128 can be controlled, so that the spacing between drum 116 and target area 102 can be precisely controlled to yield
20 the desired thickness to the layer of powder. Preferably, the spacing between the drum 116 and
25
30
35

target area 102 is constant to give a parallel motion, but other spacing options are available.

5 As the drum 116 is moved horizontally across the target area 102 from end 110 to end 112, motor 118 is activated to counter-rotate the drum 116. As shown in FIGURE 13, "counter-rotation" means the drum 116 is rotated in the direction R counter to the direction of movement M of the drum 116 horizontally across the target area 102.

10 In more detail (FIG. 13), the drum 116 is rotated at high speed in the counter-clockwise direction as it contacts the mound of powder 106 along the trailing edge 160. The mechanical action of the drum on the powder ejects the powder to the direction of movement M so that the ejected particles fall in front of the drum. As illustrated in FIGURE 13, a smooth, level layer of powder is left behind the drum 116 (between drum 116 and end 110) as depicted at 164.

15 FIGURE 13 also illustrates schematically that the powder 106 can be distributed over the target area without disturbing previously sintered powder 166 or unsintered powder 168. That is, the drum 116 is moved across the target area 102 without transmitting shear stress to the previously built up layers and without disturbing the article as it is being produced. The absence of such sheer stress permits a smooth layer of powder 106 to be distributed on the fragile substrate in the target area, which includes both the sintered particles 166 and the unsintered particles 168.

20
25
30
35 As shown in FIGURES 15 through 20, pressure, either in the form of fluid streams or electromagnetic fields, may be applied both to

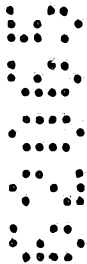

layers of sintered powder and, preferably, to a top layer of deposited, unsintered powder to produce and attain high bulk density of the deposited powder during sintering.

5 Interface and Software

10 The interface hardware operatively interconnects the computer 40 with the laser 12 and galvanometers 47, 48. The output port of the computer 40 (see FIGURES 1 and 3) is directly connected to the laser 12 to selectively modulate the laser 12. When operated in the pulsed mode, the laser 12 is easily controlled by digital inputs to the pulsed gate input of the laser. Galvanometer 48 is driven by the function generator driver 50 to drive the beam in the fast scan axis 68 independent of any control signals from the computer 40. However, a position feedback signal from the galvanometer 48 is fed to a voltage comparator 74 as shown in FIGURE 3. The other input to the comparator is connected to the digital-to-analog convertor 76 which is indicative of the least significant six bits (bits 0-5) of the user port of the computer 40. As shown in FIGURE 3, the output of the voltage comparator 74 is connected to the flag line on the user port of the computer 40. When the voltage comparator determines that the feedback signal from the galvanometer 48 crosses the signal from the digital-to-analog convertor 76, the flag line goes low causing a nonmaskable interrupt. As discussed below, the nonmaskable interrupt causes the next byte of data to put out on the user port of a computer 40.

35 Finally, as shown in FIGURE 3, the galvanometer 49 driving the aim of the laser beam 64 in the slow scan axis 70, is controlled

by a second digital to analog convertor 78. The digital-to-analog convertor 78 is driven by a counter 79 which increments with each sweep of the aim of the beam 64 in the fast scan axis 68. The eight byte counter is designed to overflow after 256 scans in the fast scan axis 68 to start a new cycle or raster scan pattern 66.

Preferably, the control information (i.e. defined boundaries of the cross-sectional regions) data for each raster pattern 66 would be determined by a CAD system given the overall dimensions and configuration of the part to be produced. Whether programmed or derived, the control information data for each raster pattern 66 is stored in the computer memory as a series of eight bit words. The data format represents a pattern of "on" and "off" regions of the laser 12, versus distance along the raster pattern 66 traveled by the aim of the beam 64. The data is stored in a "toggle-point" format where the data represents the distance along each raster scan pattern 66 where the laser is modulated (i.e. turned from on to off or from off to on). Although a "bit map" format might be used, the toggle point format has been found more efficient for the production of high resolution parts.

For each eight bit word, the least significant six bits (bits 0-5) represent the location of the next toggle point - i.e. the next location for modulation of the laser 12. The next bit (bit 6) represents whether the laser is on or off immediately before the toggle point identified in the least significant six bits. The most significant bit (MSB or bit 7) is used for looping and for controlling the slow scan axis 70 of the aim of the beam 64. Because



the Commodore 64 had limited memory, looping was required - it being understood that a computer 40 with more memory would not require looping.

5 FIGURE 6 represents the flow chart for the data metering program. The data metering program is run whenever the flagline goes low causing a non-maskable interrupt (see FIGURE 3). The interrupt causes the microprocessor of the computer 40 to retrieve a two byte interrupt vector which points to the location in memory where program control is transferred at interrupt. As shown in FIGURE 6, the data metering program first pushes the registers onto the stack and then loads the next byte of data into the accumulator. The data word is also output to the user port with the sixth bit used to modulate the laser 12 (FIGURE 3).

10 As shown in FIGURE 6, the most significant bit (MSB or bit 7) of the data word in the accumulator is examined. If the value of the most significant bit is one, that means the end of the loop has not been reached; therefore the data pointer is incremented, registers are restored from the stack, and the data metering program is exited, returning control to the microprocessor at the location of interrupt. If the most significant bit in the accumulator is zero, the data word is the last word in the loop. If the data word is the last word in the loop, the next bit in memory is a loop counter and the following two bytes are a vector pointing to the top of the loop. As can be seen from FIGURE 6, if the most significant bit equals zero (end of the loop) the loop counter (next bit) is decremented and analyzed. If the loop counter is still greater than zero, the data pointer assumes the value from the next two

memory bytes after the loop counter, registers are pulled from the stack and program control returns to the location of interrupt. On the other hand, if loop counter is zero, the data pointer is incremented by three and the loop counter is reset to ten before exiting the program. It can be appreciated that the need for such looping is absolved if the memory size of the computer 40 is adequate.

10 Example

In FIGURES 4 and 5, an example part 52 is illustrated. As can be seen from the drawing, the example part 52 assumes an unusual shape in that it is not symmetrical and would be difficult to fabricate using conventional machining methods. For reference purposes, the part 52 includes an outer base structure 80 having an interior cavity 82 and a pillar 84 disposed within the cavity 82 (see FIGURE 4). FIGURE 5 shows the part 52 within the confinement structure 28 defining the target area 26 illustrated in FIGURE 1. As shown in FIGURE 5, some of the powder 22 is loose, while the remainder of the powder is selectively sintered to comprise the structure of the part 52. FIGURE 5 is shown in vertical section with parts broken away and outlined in phantom to show the sintered cohesive portions of the part 52.

FIGURE 7 shows a horizontal cross-sectional region, taken along line 7-7 of FIGURE 4. FIGURE 7 represents a discrete layer 86 associated with the cross-sectional region of the part being produced. As such, the sintered layer 86 of FIGURE 7 is a product of a single raster pattern 66 as illustrated in FIGURE 2.

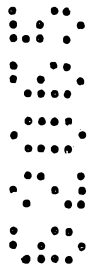

For reference purposes, a sweep line through the sintered layer 86 has been labeled "L." FIGURE 8 illustrates the software and hardware interface operation during the sweep L. The top graph shows the position of feedback signal from the fast axis galva 48 and the output signal of the first digital to analog convertor 76 (compare FIGURE 3). The voltage comparator 74 generates an output signal to the flag line of the computer 40 every time the feedback signal and first D/A output signal cross.

In the top graph of FIGURE 8, these points are labeled T to represent toggle points. As can be seen from the bottom graph of FIGURE 8, the flag line generates a nonmaskable interrupt corresponding to each toggle point T. The sixth bit of each data word is analyzed and the current state of the laser 12 will reflect the value. The penultimate graph of FIGURE 8 shows the laser modulation signal for the sweep line L of FIGURE 7. The second graph of FIGURE 8 shows that a high-going edge in the most significant bit will be encountered at the end of each sweep of the aim of the laser beam 64 in the fast scan axis 68. As shown in FIGURES 3 and 6, the counter 79 increments on a high going edge, and outputs a signal to the second digital-analog convertor 78 to drive the slow axis galvanometer 49.

* * *

As can be seen from the example illustrated in the drawing, parts of complex shape can be produced with relative ease. Those skilled in the art will appreciate that the part 52 illustrated in FIGURE 4 would be difficult to produce using conventional machining methods. In particular, machine tool access would make

the fabrication of cavity 82 and pillar 84 difficult, if not impossible, to produce if the part 52 were of a relatively small size.

5 In addition to avoiding the access problem, it will be appreciated that the production accuracy is not dependent upon machine tool wear and the accuracy of mechanical components found in conventional machine tools. That is, the accuracy and tolerances of the parts produced by
10 the method and apparatus of the present invention are primarily a function of the quality of the electronics, the optics, and the implementing software. Of course, heat transfer and material considerations do affect the tolerances obtainable.
15

Those skilled in the art will appreciate that conventional machining techniques require considerable human intervention and judgment. For example, a conventional machining process, such as milling, would require creativity to
20 make such decisions as tool selection, part segmenting, sequence of cuts, etc. Such decisions would even be more important when producing a control tape for a tape control milling machine. On the other hand, the apparatus of the present invention only requires the data relating to each cross-sectional region of the part being produced. While such data can be simply programmed into the computer 40,
25 preferably, the computer 40 includes a CAD/CAM system. That is, the CAD/CAM portion of the computer 40 is given the overall dimensions and configurations of the desired part to be produced and the computer 40 determines the boundaries for each discrete cross-sectional
30 region of the part. Thus, a vast inventory of part information can be stored and fed to the
35

computer 40 on a selectable basis. The apparatus 10 produces a selected part without set-up time, part specific tooling, or human intervention. Even the complex and expensive dies associated with powder metallurgy and conventional casting techniques are avoided.

While large quantity production runs and certain part material characteristics might be most advantageously made using conventional fabrication techniques, the method and apparatus 10 of the present invention is useful in many contexts. In particular, prototype models and casting patterns are easily and inexpensively produced. For example, casting patterns are easily made for use in sand casting, lost wax casting, or other forming techniques. Further, where desired quantities are very small, such as with obsolete replacement parts, production of such replacement parts using the apparatus 10 of the present invention has many advantages. Finally, the use of the apparatus 10 may be useful where size of production facilities is a major constraint, such as on-ship or in outer-space. Similarly, use of the methods and apparatus shown in FIGURES 16 through 20 may also be useful for production where the size of facilities or lack of gravity is a major constraint.

Further modification and alternative embodiments of the apparatus of this invention will be apparent to those skilled in the art in view of this description. Accordingly this description is to be construed as illustrative only and is for the purpose of teaching those skilled in the art the manner of carrying out the invention. It is to be understood that the forms of the invention herein shown and

described are to be taken as the presently preferred embodiments. Various changes may be made in the shape, size and arrangement of parts. For example, elements or materials may be substituted for those illustrated and described herein, parts may be reversed, and certain features of the invention may be utilized independently of the use of other features, all as would be apparent to one skilled in the art after having the benefit of this description of the invention.

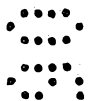

THE CLAIMS DEFINING THE INVENTION ARE AS FOLLOWS:-

5 1. An apparatus for producing a part comprising: beam means for selectively emitting a directed energy beam; structure for providing a target area for producing the part; means for depositing a powder into said target area; control means for moving the aim of the beam and for modulating the beam means to selectively sinter within defined boundaries a layer of powder deposited in said target
10 area, the control means being operable to effect selective sintering of sequential layers of powder within respective defined boundaries to produce a part comprising a plurality of layers sintered together; and means for attaining a high bulk density in said powder in said target area.

 2. The apparatus of claim 1 wherein said means for attaining a high bulk
15 density enables attaining a high bulk density during sintering.

 3. The apparatus of claim 1 wherein said depositing means comprises apparatus to electrostatically charge and dispense said powder.

 4. The apparatus of claim 3 wherein said means for attaining comprises means for producing an electromagnetic field proximate said target area, said
20 electromagnetic field inducing high bulk density in said powder in said target area during sintering.

 5. The apparatus of claim 1 wherein said powder comprises polarizable elements and said depositing means comprise apparatus to dispense said powder.

 6. The apparatus of claim 5 wherein said means for attaining comprises
25 means for producing an electromagnetic field proximate said target area, said electromagnetic field inducing high bulk density in said powder in said target area during sintering.

 7. The apparatus of claim 6 wherein said means for producing an electromagnetic field enables production of a field having varying field strengths
30 across said target area.

 8. The apparatus of claim 1 wherein said depositing means comprises an apparatus to dispense said powder with a first electrical charge and said target area



having a second electrical charge, said first electrical charge being of opposite charge to said second electrical charge.

9. The apparatus of claim 1 wherein said depositing means comprises: apparatus to dispense a first portion of said powder with a first electrical charge on
5 said first portion; and a contouring means passable proximal said dispensed first portion.

10. The apparatus of claim 9 wherein said depositing means further comprises apparatus to dispense a second portion of said powder with a second electrical charge on said second portion, said first electrical charge being of opposite
10 charge to said second electrical charge.

11. The apparatus of claim 1 wherein said depositing means further comprises a device for distributing a mound of powder at one end of a region as a layer of powder in the region, comprising: electrically charged drum means; means for moving the drum from said one end of the region to another end of the region
15 with a desired spacing between said region and drum; means for rotating the drum counter to the direction of movement of the drum from said one end to said other end, said drum means being operable when counter-rotated and moved from said one end to said other end to contact said mound and eject powder in said direction of movement to leave a layer of powder between the drum means and said one end
20 having a thickness of approximately said desired spacing.

12. The apparatus of claim 1 wherein said powder is magnetic and said means for attaining comprises means for producing an electromagnetic field proximate said target area, said electromagnetic field inducing high bulk density in said powder in said target area during sintering.

25 13. The apparatus of claim 1 wherein said means for attaining comprises apparatus for directing a fluid stream to said powder deposited in said target area inducing high bulk density in said powder in said target area during sintering.

14. The apparatus of claim 1 wherein said means for attaining comprises apparatus to enable the application of centrifugal force to said deposited powder to
30 induce high bulk density in said powder in said target area.

15. A method of producing a part comprising the steps of:
depositing a powder comprising at least a first material and a second



material onto a target surface as a powdery layer, said first material being a metal and having a lower softening temperature than said second material,

directing an energy beam at the target surface in such a manner that a selected portion of said powdery layer, corresponding to a cross-sectional region of said part, is heated by the energy of said beam to a temperature so as to bond said second material therewith in said selected portion,

repeating said depositing and directing steps for a plurality of powdery layers so that bonded portions of said plurality of powdery layers bond to one another to form a mass in layerwise fashion,

removing unbonded portions of the powder to yield the mass.

16. The method of claim 15 wherein said powder comprises intermixed quantities of said first and second materials.

17. The method of claim 15 wherein said powder consists essentially of said second material coated with said first material.

18. A method of producing a part comprising the steps of: depositing powder onto a target surface; increasing the bulk density of said powder; and directing an energy beam at the target surface in such a manner that a selected portion of said powder corresponding to a cross-sectional region of the part is sintered by the energy of said beam.

19. The method of claim 18 wherein said step of increasing the bulk density is performed during said directing step.

20. The method of claim 18 wherein said step of depositing comprises: electrostatically charging said powder; and dispensing said powder.

21. The method of claim 18 wherein said step of depositing comprises: electrostatically charging said powder; and dispensing said powder; and wherein said step of increasing the bulk density comprises: producing an electromagnetic field proximate said target surface.

22. The method of claim 18 wherein said powder is polarizable.

23. The method of claim 18 wherein said powder is polarizable; and wherein said step of increasing the bulk density comprises: producing an electromagnetic field proximate said target surface.

24. The method of claim 18 wherein said step of depositing comprises:



dispensing said powder with a first electrical charge; and placing a second electrical charge on said target surface, said first electrical charge being of opposite charge to said second electrical charge.

25. The method of claim 18 wherein said step of depositing comprises:
5 placing a first electrical charge on a first subportion of said powder; dispensing said first subportion; and contouring said dispensed first subportion.

26. The method of claim 18 wherein said step of depositing comprises:
placing a first electrical charge on a first subportion of said powder; dispensing said first subportion; contouring said dispensed first subportion; placing a second
10 electrical charge on a second subportion of said powder; and dispensing said second subportion; wherein said first electrical charge is opposite said second electrical charge.

27. The method of claim 18 wherein said powder is magnetic; and wherein said step of increasing the bulk density comprises producing an electromagnetic field
15 proximate said target surface.

28. The method of claim 18 wherein said powder is polarizable; and wherein said step of increasing the bulk density comprises producing an electromagnetic field.

29. The method of claim 18 wherein said step of increasing the bulk
20 density comprises directing a fluid stream to said deposited powder.

30. The method of claim 18 wherein said step of increasing the bulk density comprises applying centrifugal force to said deposited powder.

31. A method of producing a part comprising the steps of:
depositing a powder onto a target surface, said powder comprising first
25 and second materials;

directing an energy beam at the target surface in such a manner that a selected portion of said powder corresponding to a cross-sectional region of the part is heated by the energy of said beam to a sufficient temperature that said first material in said selected portion adheres particles of said second material into a
30 mass thereat;

repeating said depositing and irradiating steps for a plurality of layers so that portions of the masses formed in adjacent layers bond to one another; and



removing unbonded portions of the powder to yield the part; and heating the mass after said removing step.

32. The method of claim 31, wherein said target surface is disposed within an environment comprising a gas which promotes sintering; and wherein said directing step sinters said first material in said selected portion of said powder.

33. The method of claim 31, wherein said energy beam is at a selected wavelength; and wherein said first material absorbs energy at the selected wavelength to a greater degree than said second material.

34. The method of claim 31, further comprising controlling the temperature of the bonded and unbonded powder at the target surface.

35. The method of claim 31, wherein said first material has a lower softening temperature than said second material and further comprising:

during said irradiating step, exposing said powder to a gas phase to promote infiltration of the first material within particles of the second material.

36. The method of claim 31, wherein said directing step sinters said first material in the selected portion of said powder.

37. The method of claim 31, wherein said heating step dissociates said first material and sinters the second material.

38. The method of claim 31, wherein said annealing forms an alloy of said first and second materials.

39. The method of claim 31, wherein said second material is electrically conductive.

40. The method of claim 39, wherein said first material is an electrically insulating polymer.

41. The method of claim 31, wherein said second material is crystalline; and wherein said directing step adheres particles of said second material in each successive layer into the mass epitaxially with particles of said second material at portions of the prior layer of powder.

42. An apparatus for producing a part, substantially as hereinbefore described with reference to the accompanying drawings.

20
25
30



43. A method of producing a part, substantially as hereinbefore described with reference to the accompanying drawings.

Dated this 21st day of September, 1993

5 BOARD OF REGENTS, THE UNIVERSITY OF TEXAS SYSTEM

By its Patent Attorneys

Davies Collison Cave

8
2
0

8
2
0



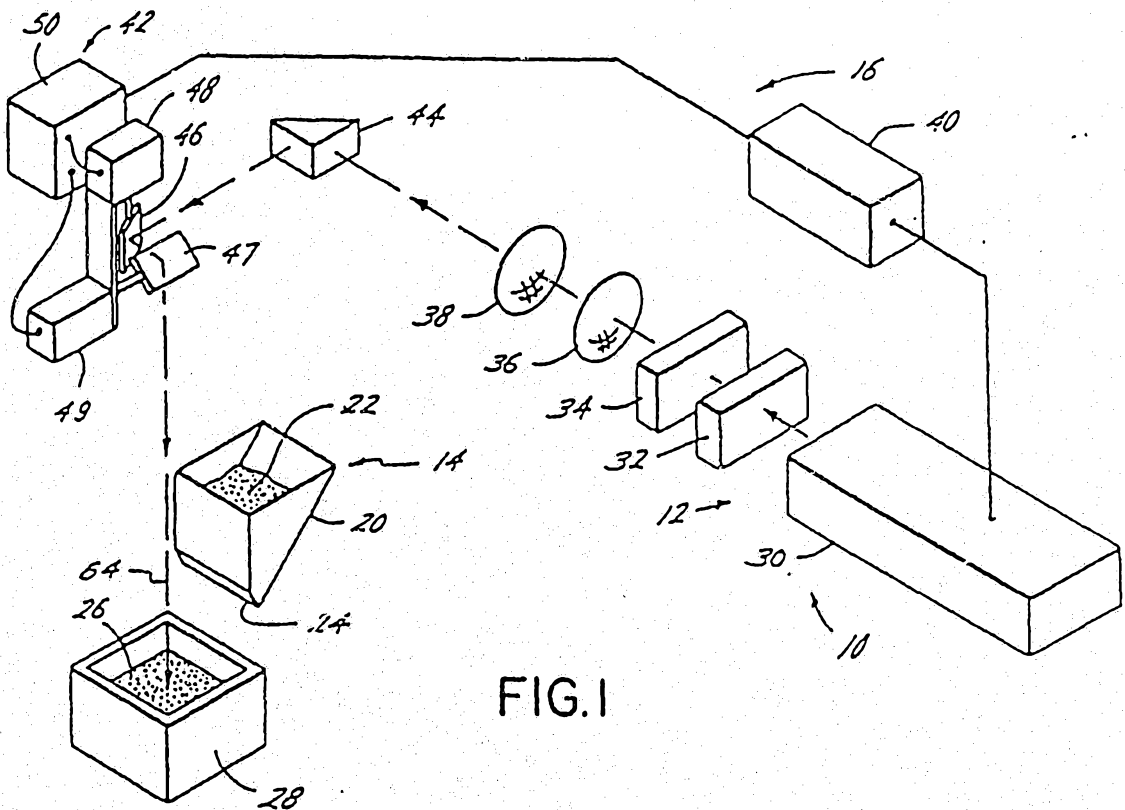

FIG. 1

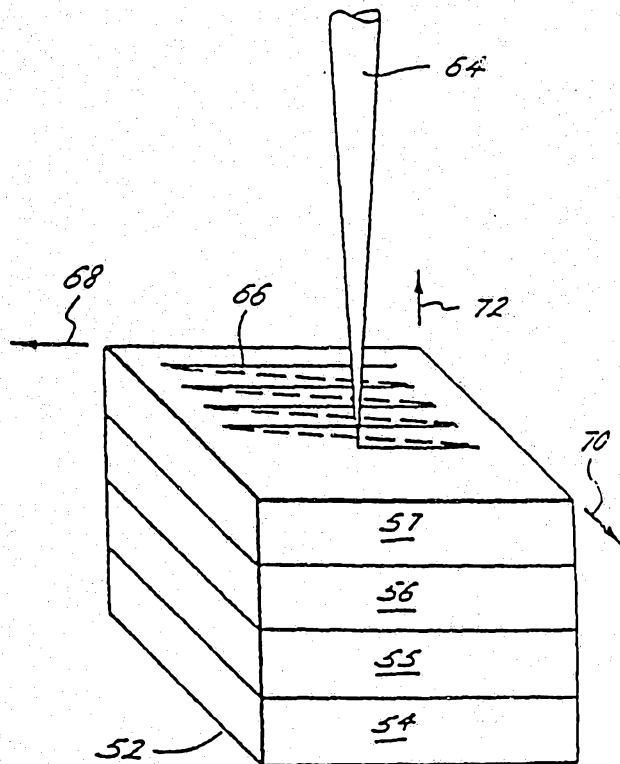

FIG. 2



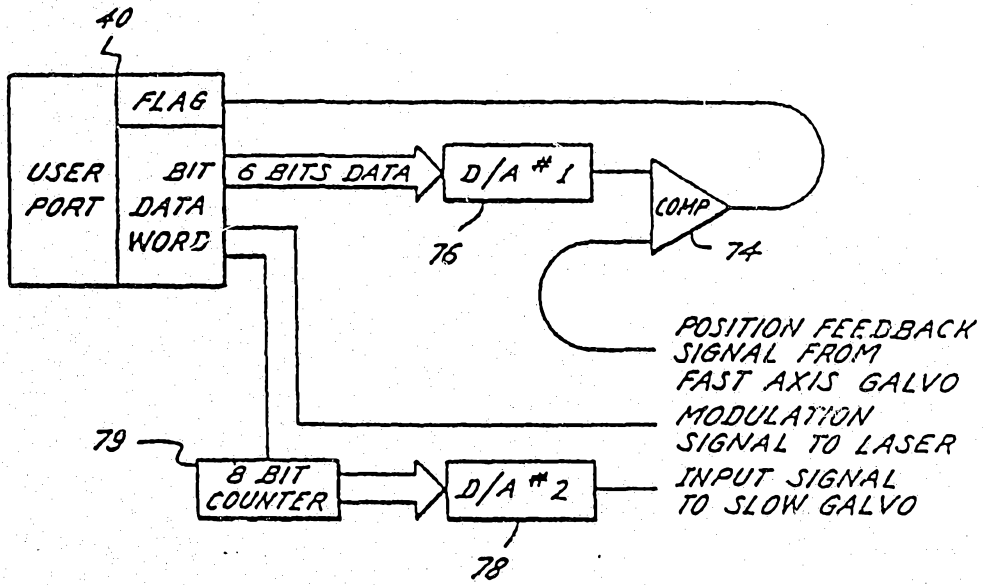

FIG. 3

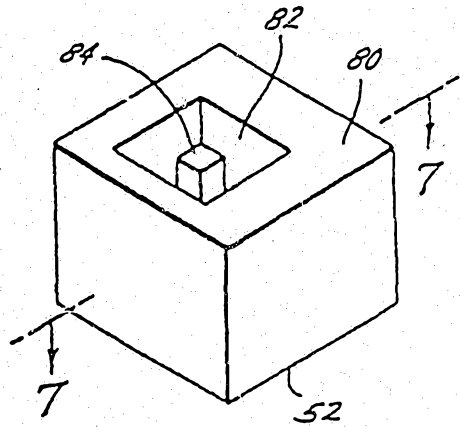

FIG. 4

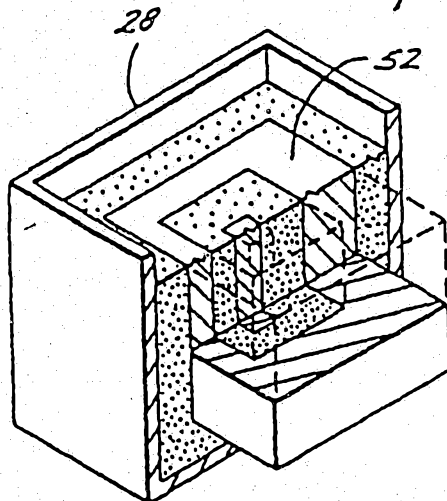

FIG. 5



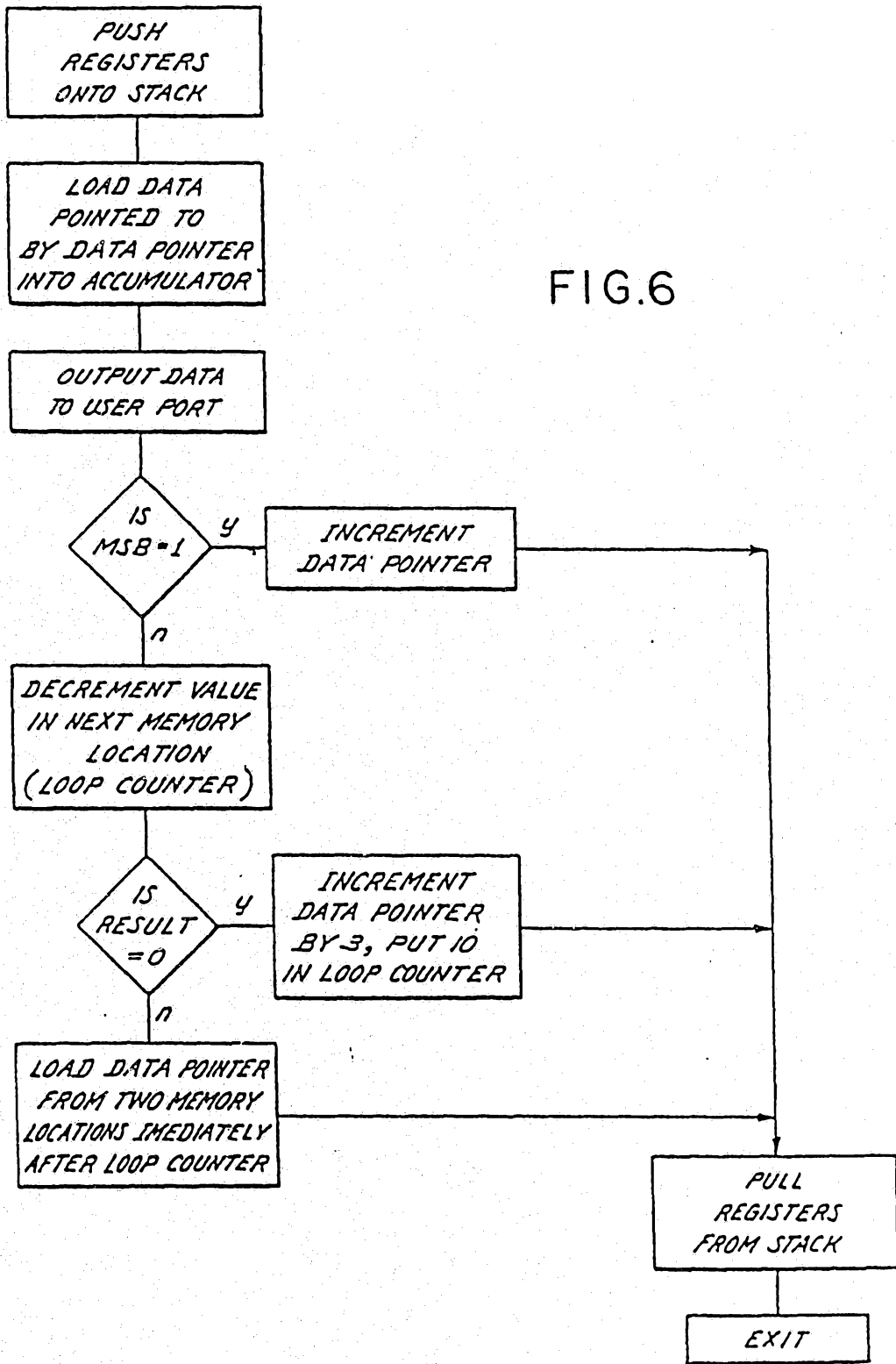

FIG. 6

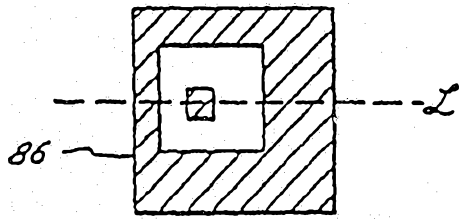

FIG. 7

FIG. 8

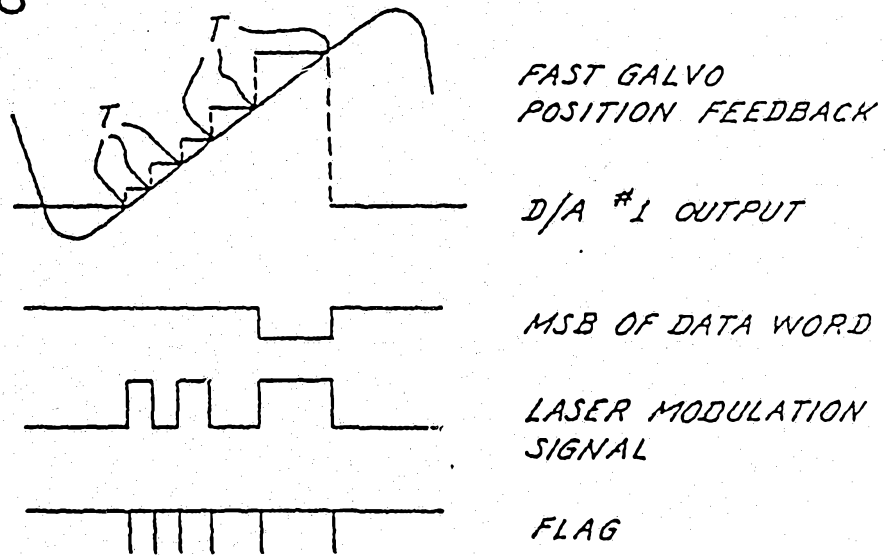
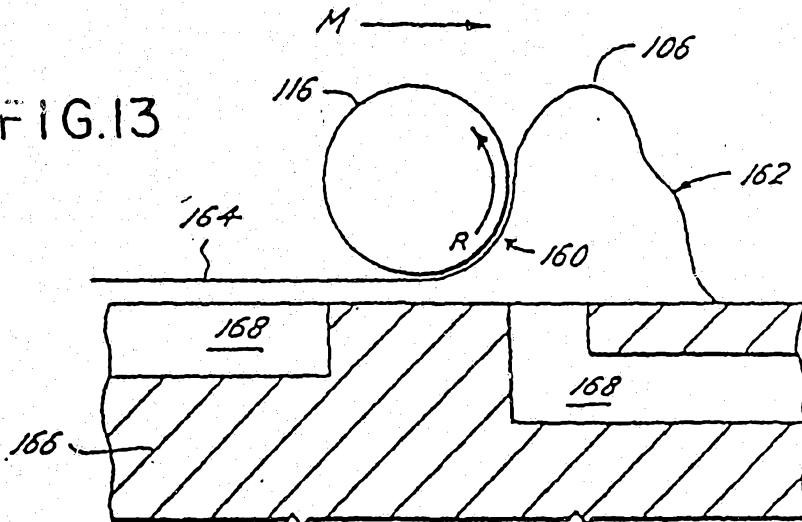

FIG. 13



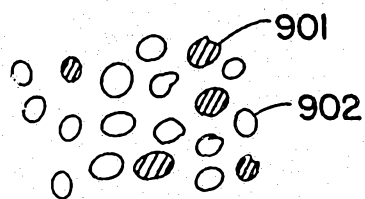

FIG. 9

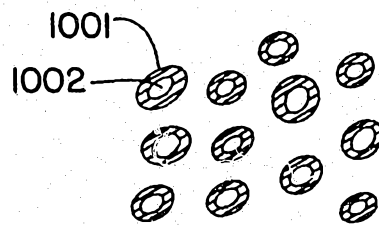

FIG. 10

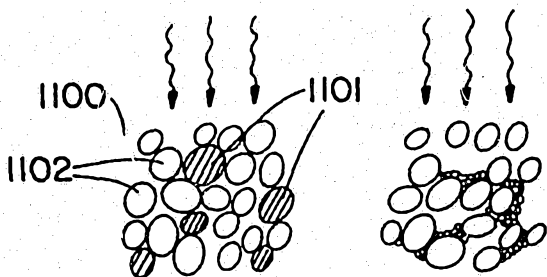

FIG. 11a

FIG. 11b

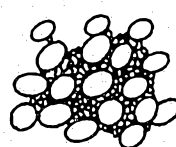

FIG. 11c

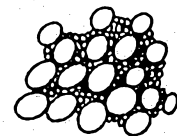

FIG. 11d

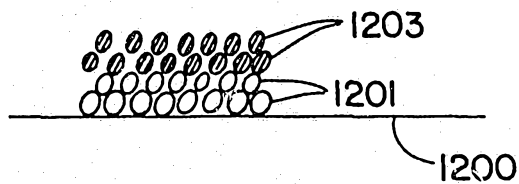

FIG. 12

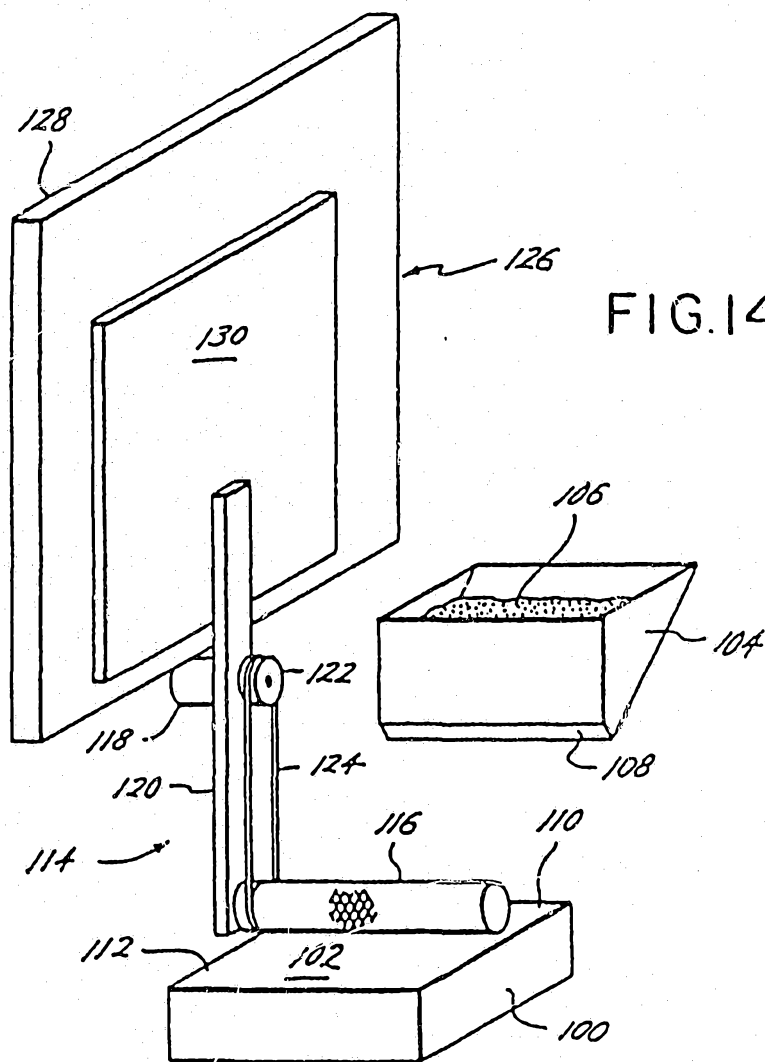
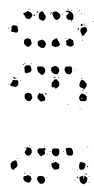

FIG. 14



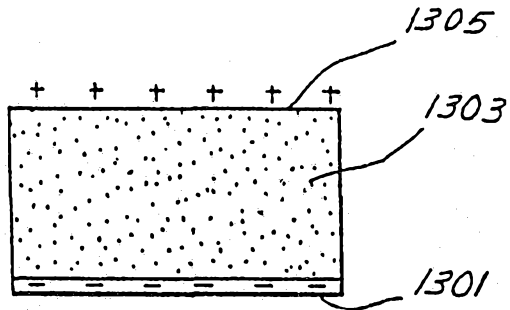

FIG. 16

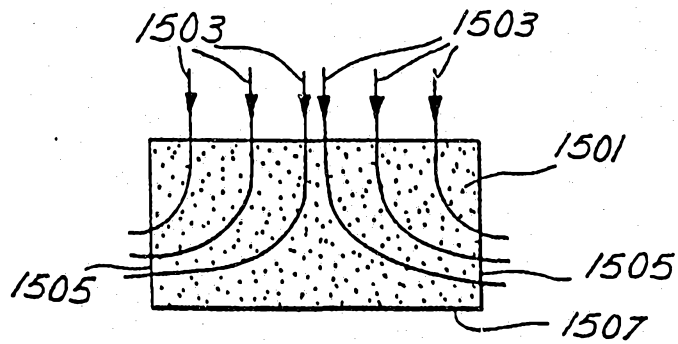

FIG. 18

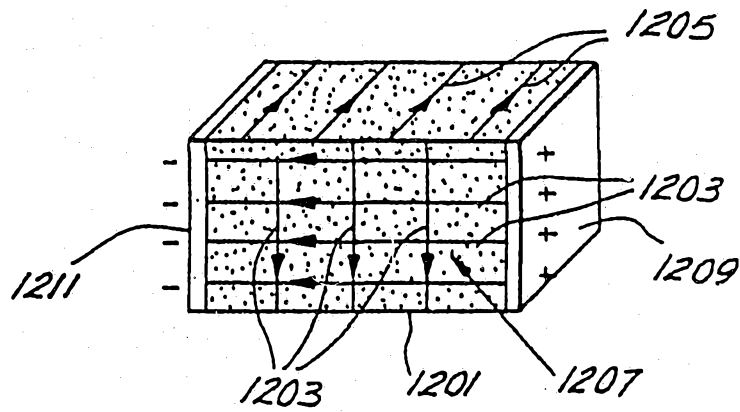
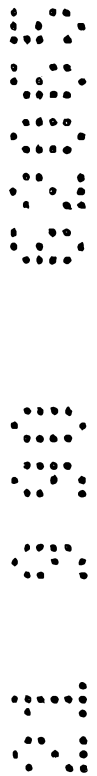

FIG. 15



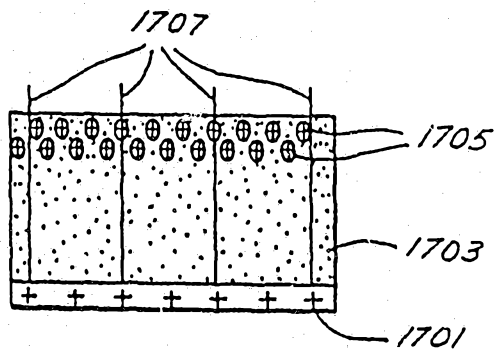

FIG. 20

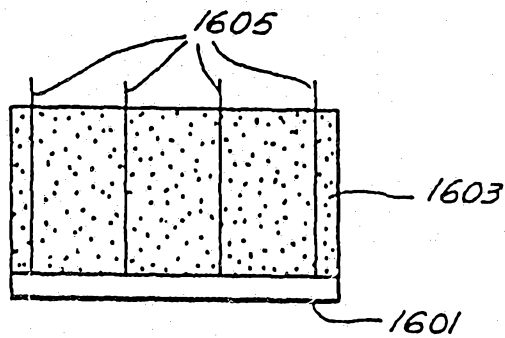

FIG. 19

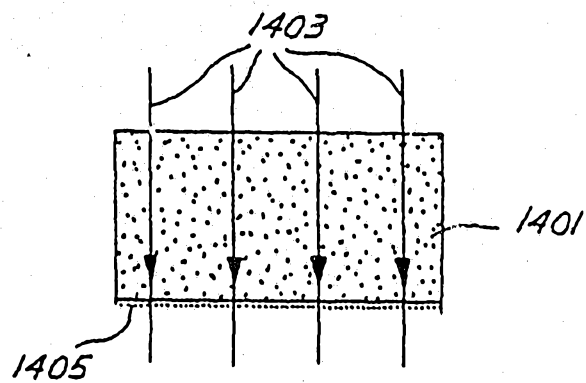

FIG. 17